



Natural Resources
Canada

Ressources naturelles
Canada



ecoENERGY
an ecoACTION initiative

GUIDE TO ENERGY EFFICIENCY OPPORTUNITIES IN THE CANADIAN PLASTICS PROCESSING INDUSTRY



IN COLLABORATION WITH THE CANADIAN PLASTICS INDUSTRY ASSOCIATION



CIPEC

Canadian
Industry
Program for
Energy
Conservation

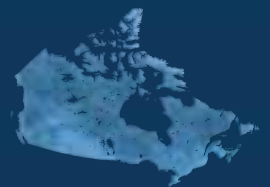

Canada

For more information or to receive additional copies of this publication, write to

Canadian Industry Program for Energy Conservation

c/o Natural Resources Canada

580 Booth Street, 18th Floor

Ottawa ON K1A 0E4

Tel.: 613-995-6839

Fax: 613-992-3161

E-mail: cipec-peeic@nrcan.gc.ca

Web site: oee.nrcan.gc.ca/cipec

or

Canadian Plastics Industry Association

5915 Airport Road, Suite 712

Mississauga ON L4V 1T1

Tel.: 905-678-7748

Fax: 905-678-0774

Web site: www.cpia.ca



Photos courtesy of the Canadian Plastics Industry Association

ISBN 978-0-662-45754-1

Catalogue No. M144-151/2007E (print)

ISBN 978-0-662-46736-6

Catalogue No. M144-151/2007E-PDF (electronic)

© Her Majesty the Queen in Right of Canada, 2007

Library and Archives Canada Cataloguing in Publication

Guide to energy efficiency opportunities in the Canadian plastics processing industry.

Aussi disponible en français sous le titre : Guide sur les possibilités d'accroître l'efficacité énergétique dans l'industrie de transformation des matières plastiques au Canada.

1. Plastics industry and trade—Energy consumption—Canada. 2. Plastics industry and trade—Energy conservation—Canada. 3. Energy auditing—Canada.

I. Canadian Industry Program for Energy Conservation II. Canada. Natural Resources Canada III. Canadian Plastics Industry Association

TJ163.5.S83B46 2007

338.4'766840682

C2007-980163-3



Recycled Paper

TABLE OF CONTENTS

1. INTRODUCTION	2
2. SECTOR PROFILE – CANADIAN PLASTICS PROCESSING SECTOR OVERVIEW	6
2.1 Sector Activities	6
2.2 Industry Structure and Plant Profile	8
2.3 Current Economic Status	10
2.4 Resource Usage	12
2.4.1 Materials	13
2.4.2 Energy	14
2.4.3 Water	17
2.5 Process Residuals	17
2.5.1 Air Residuals (Gases and Dust)	17
2.5.2 Wastewater and Liquid Wastes	19
2.5.3 Solid Waste	20
2.5.4 Noise	20
2.6 Environmental Legislation	20
3. GREENHOUSE GAS EMISSIONS FROM THE PLASTICS PROCESSING INDUSTRY	22
3.1 Introduction	22
3.1.1 Greenhouse Gases	22
3.1.2 Energy and Greenhouse Gas Emissions	23
3.1.3 Hydrofluorocarbon Emissions from Plastics Processing	26
3.2 Opportunities for Reducing Greenhouse Gas Emissions	26
3.2.1 Canadian Industry Program for Energy Conservation	28
3.3 Summary	28
4. GENERIC PROCESSES, PRODUCTS AND PRODUCT MARKETS	32
4.1 Generic Processes and Typical Products	32
4.2 Use of Plastic Products in Various Market Segments	33

5. GENERIC PROCESSES AND AUXILIARY SYSTEMS DESCRIPTIONS	36
5.1 Profile Extrusion.	36
5.2 Thermoplastic Injection Moulding.	38
5.3 Flat Film or Sheet Extrusion.	41
5.4 Blown-Film Extrusion	42
5.5 Blow Moulding.	44
5.5.1 Extrusion Blow Moulding	44
5.5.2 Injection Blow Moulding	45
5.6 Compression Moulding of Thermoset Plastics.	46
5.7 Foam Moulding	48
5.8 Auxiliary Systems.	50
6. GENERIC IMPROVEMENT OPPORTUNITIES	58
6.1 Material Conservation.	58
6.1.1 General Plant Supplies	58
6.1.2 Consumables and Maintenance Supplies	59
6.1.3 Resin Conservation	60
6.2 Energy Conservation	62
6.2.1 Specifying Energy-Efficient Equipment	63
6.2.2 Replacing Inefficient Equipment During Maintenance	64
6.2.3 Motors	64
6.2.4 Variable Speed Drives	65
6.2.5 Hydraulic Pumps	67
6.2.6 Hydraulic Systems	67
6.2.7 Machine Components	68
6.2.8 Screws and Barrels	68
6.2.9 Energy Management Practices	68
6.3 Water Conservation.	70
6.3.1 System Design Considerations	71
6.3.2 Calculations	72

6.4 Auxiliary Systems and Facility Equipment	75
6.4.1 Dryers	75
6.4.2 Electrical Systems	77
6.4.3 Compressed-Air Systems	77
6.4.4 Lighting	78
6.4.5 Process Insulation	80
6.4.6 Building Heating, Cooling and Ventilation	80
6.5 Emissions Reduction	81
6.5.1 Air Residuals – Gases and Dust	81
6.5.2 Wastewater and Liquid Wastes	83
6.5.3 Solid Waste	84
6.5.4 Noise	84
6.5.5 Stormwater	84
6.6 Environmental Management Systems	84
6.7 Case Studies in Resource Conservation	87
7. NEW AND EMERGING TECHNOLOGIES	90
7.1 Raw Material Developments	90
7.2 Robotics	90
7.3 All-Electric Injection-Moulding Machine	91
7.4 Microwave Drying	92
7.5 Granulators	92
7.6 Rapid Prototyping	93
7.7 Gas-Assisted Injection Moulding	93
7.8 Co-Injection Moulding	93
7.9 Toolmaking Technology	94
7.10 Volatile Organic Compound (VOC) Control Technologies	94
7.11 Synchronous Torque Motors	95

8. BENCHMARKING AND PERFORMANCE MONITORING	98
8.1 Raw Materials Usage	98
8.2 Unit Electrical Energy Use.	98
8.3 Unit Natural Gas Energy Use	99
8.4 Reduction in CO ₂ Emissions per Unit of Energy	99
8.5 Unit Water Use.	99
9. OTHER HELPFUL INFORMATION	102
9.1 Miscellaneous Reference Materials	102
9.2 Plastics Processing Industry Associations.	103
9.3 Industry Directories and Guides.	103
9.4 Environmental/Resource Audit Guidance Documents	104
9.5 Pollution Prevention Guidance Documents	105
9.6 Environmental Management Systems.	105
9.7 Web Sites	105
9.8 Acronyms	106
9.9 Glossary	107
APPENDICES	
Appendix I : ISO 14000 Standard Series	112
Appendix II : Scope of Generic Plastics Manufacturing Processes Used in Canada.	113
Appendix III : Selected Case Studies from <i>Improving Energy Efficiency at U.S. Plastics Manufacturing Plants</i>	114

I

INTRODUCTION



1. INTRODUCTION

The plastics processing sector represents a large and growing sector of the Canadian economy for which energy efficiency is a key issue. This sector has worked co-operatively with provincial/territorial and federal government agencies to promote resource conservation and to highlight opportunities to its stakeholders on how to improve energy performance. An excellent example of this collaboration is the *Guide to Energy Efficiency Opportunities in the Canadian Plastics Processing Industry*, which was prepared as a joint effort between the Canadian Plastics Industry Association (CPIA) and the Canadian Industry Program for Energy Conservation (CIPEC). This guide is intended to be a helpful tool that can be used in conjunction with existing skills and knowledge among stakeholders who share an interest in the plastics processing sector.

This guide has been updated from the original document produced in 1997. The new version provides additional information and guidance in the area of greenhouse gas emissions reduction. The purpose of this guide is to help plastics manufacturers identify equipment, auxiliary systems and process improvements that will reduce production costs, improve their competitive position, reduce pollution, and conserve energy, water and other resources.

Since the publication of the original guide in 1997, Canada has introduced a national strategy to reduce the country's total greenhouse gas emission by 60 to 70 percent by 2050. While the Canadian plastics processing industry is not a major emitter of greenhouse gases, plastics processors can reduce costs and greenhouse gas emissions by conserving energy. Reducing greenhouse gases and how it relates to the plastics processing industry are described in Chapter 3 of this guide.

The primary users of this guide will be the executives in the plastics processing industry who make equipment purchases, process improvements and maintenance decisions in a competitive environment. However, the audience also includes all stakeholders in the plastics manufacturing industry. Other readers who will benefit include owners, managers, production supervisors, maintenance staff, employees, suppliers, designers, consultants and industry associations. For readers who are not familiar with the industry and its technology, Chapter 5, "Generic Processes and Auxiliary Systems Descriptions," offers simplified process descriptions and generic process diagrams.

The processes described herein are estimated to include over 90 percent of the market activity in Canada. The significant thermoplastic processes that are discussed include the following:

- profile extrusion;
- thermoplastic-injection moulding;

- flat film or sheet extrusion;
- blown-film extrusion; and
- blow moulding.

The two thermoset processes that are discussed include the following:

- compression moulding of thermoset plastics; and
- foam moulding.

In addition to these processes, auxiliary equipment and general plant systems common to most plastics operations are also discussed. The plastics processing industry uses a broad range of technologies, not all of which are discussed in this guide. A more complete listing of processes may be found in Appendix III, which outlines the scope of generic plastic manufacturing processes currently used in Canada.

An effective resource conservation and pollution prevention program requires the following components:

1. An understanding of current performance in terms of resource consumption and efficiency.
2. A detailed site-specific assessment to identify specific technical opportunities for improvement.
3. A management practices framework that will support and influence the implementation of conservation opportunities.
4. A continuous improvement approach to resource conservation activities.

As the level of technical analysis required for these components is beyond the scope of this guide, only an introduction to these components is provided here.

2

SECTOR PROFILE – CANADIAN PLASTICS PROCESSING SECTOR OVERVIEW

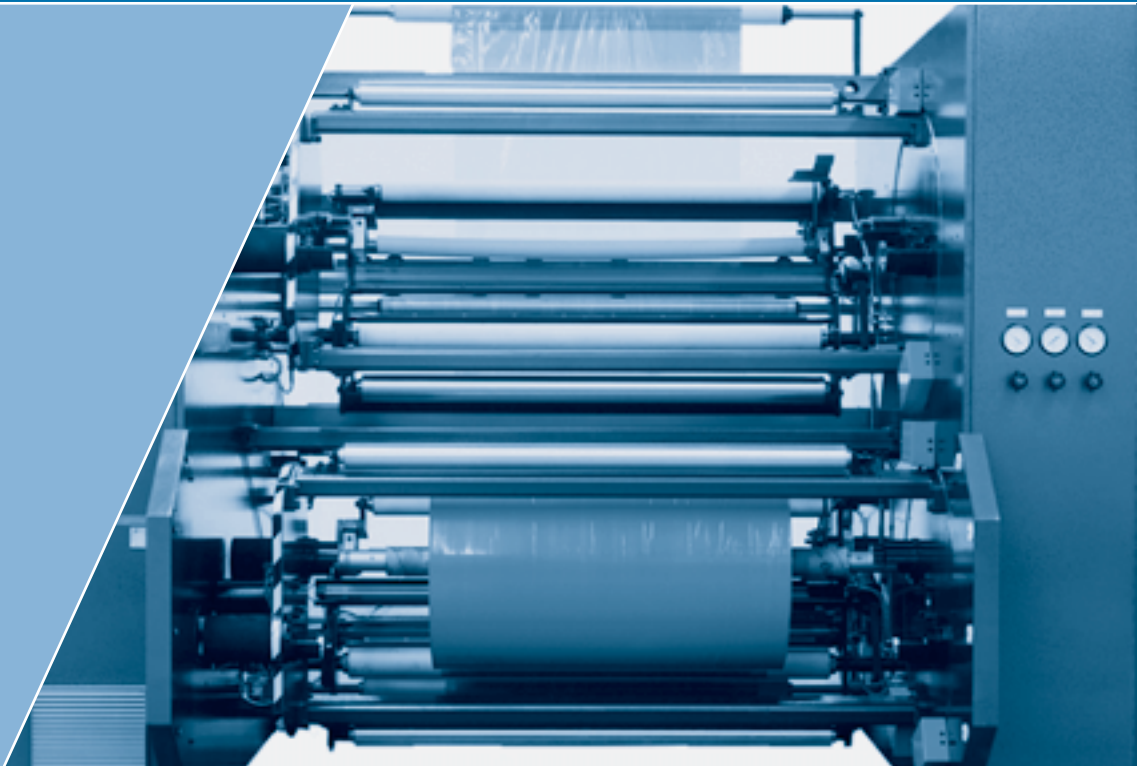

2. SECTOR PROFILE – CANADIAN PLASTICS PROCESSING SECTOR OVERVIEW

The “Sector Activities” section in this chapter focuses on the nature of Canada’s plastics processing industry. The plastics processing industry is a significant part of a larger plastics manufacturing sector. Canadian material suppliers manufacture resins from petrochemical and other feedstocks. Canada also has several world-class manufacturers of processing machinery and is a major producer of tooling for domestic and international plastics processors.

Canadian sales revenue in the plastics processing sector exceeded \$38 billion in 2004. This chapter discusses some of the major economic factors that affect Canadian processors’ ability to compete in international markets. Trade balances and trends are also examined.

This chapter also discusses the use of resources and energy by the plastics processing industry and provides a context for discussing savings opportunities.

The “Process Residuals” section discusses wastes and emissions that may be generated from plastics processing. Environmental legislation relevant to the Canadian plastics processing sector is also discussed in this section.

2.1 SECTOR ACTIVITIES

The plastics processing sector is characterized by many different processes and applications that use an ever-increasing variety of raw materials. In addition to plants devoted to producing custom products for third parties, many Canadian manufacturers have unique “captive” plastics processing operations that manufacture finished goods for sale or components for other end products. This diversity creates difficulty in assembling accurate statistics for the industry. However, it is clear that the sector represents a significant portion of Canada’s industrial activity and continues to experience a growth rate well in excess of the average for all manufacturers.

In 2004, the Canadian plastics processing sector generated about \$38.4 billion in shipments and employed more than 146,000 people in approximately 3,800 companies. The major markets served by the plastics industry are packaging, construction and transportation (automotive). These segments account for 34, 26 and 18 percent, respectively, of the total resin processed in Canada.

A brief and current profile of the plastic products processing sector is outlined in Table 2-1.

Table 2-1 2004 Plastics Processing Industry Key Figures

	Canada
Total Canadian Value Chain	\$50.9 billion
Shipments by Processors	\$38.4 billion
Shipments by Raw Material, Machinery and Mould Suppliers	\$12.5 billion
Total Processors Employment	146,880
Total Suppliers Employment	24,500
Total Sector Employment	171,380
Number of Plants	3,757
Resin Capacity (metric tonnes)	5.2 million
Plastics GDP* Growth vs. All Manufacturing	2.7 times faster
All Manufacturing GDP Growth	17% since 1999
Plastics Products GDP Growth	46.1% since 1999

* *gross domestic product*

Source: *Canadian Plastics Industry Association (CPIA)*

Following a brief period of decline in shipments in the early 1990s, which was due to several macro-economic factors, Canadian plastic products shipments have increased every year for the past 10 years, as shown in Figure 2-1. For the five-year period of 1995 to 1999, Canadian plastic products shipments increased by an average of 7.6 percent per year; and for the five-year period of 2000 to 2004, shipments increased by an average of 5.8 percent per year.

The plastics products industry has shown strong growth over the last decade with plastics products gross domestic product (GDP) outgrowing the overall manufacturing sector GDP growth by 2.7 times since 1999.

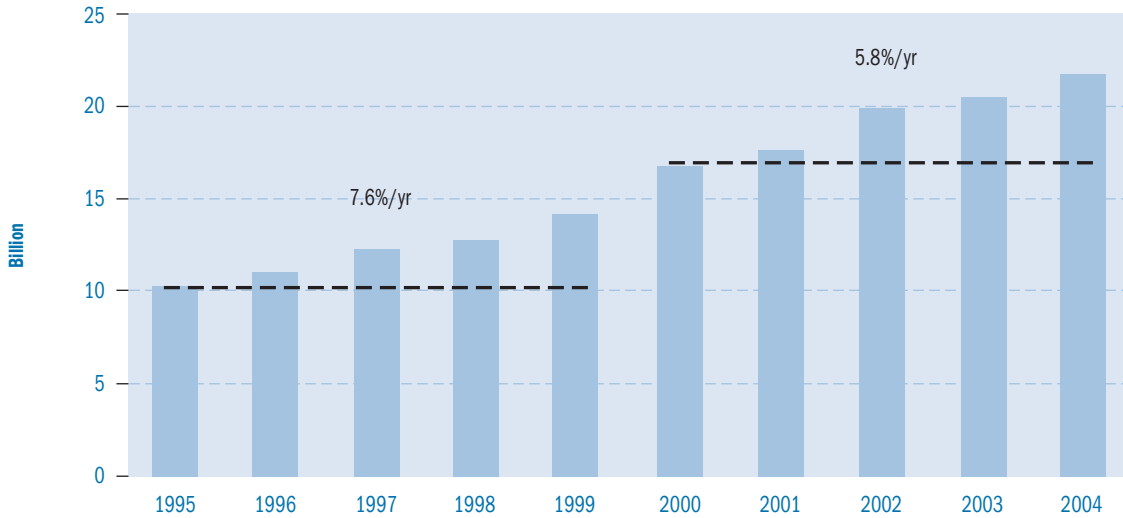
Figure 2-1 Canadian Plastics Industry Shipments

2.2 INDUSTRY STRUCTURE AND PLANT PROFILE

Although some consolidation and rationalization has taken place in the last few years, Canada's plastics processing industry continues to be characterized by a large number of small- and medium-sized enterprises.

The average Canadian establishment employs approximately 40 people and has annual sales of approximately \$10 million. A number of Canadian plastics processors have emerged as significant players in the North American market, each employing several hundred to over a thousand people. Approximately two thirds of these larger companies are Canadian-owned. Each of these firms has sales volumes in excess of several hundred million dollars, and several have international affiliates or subsidiaries.

The structure of the industry showing the flow from raw materials to products is shown in Figure 2-2. The custom and proprietary processors produce products that are sold to other manufacturers or marketed directly by the producer. The captive processors incorporate the plastic products manufactured as components into other products.

Figure 2-2 Position of Processors within the Plastics Industry Structure

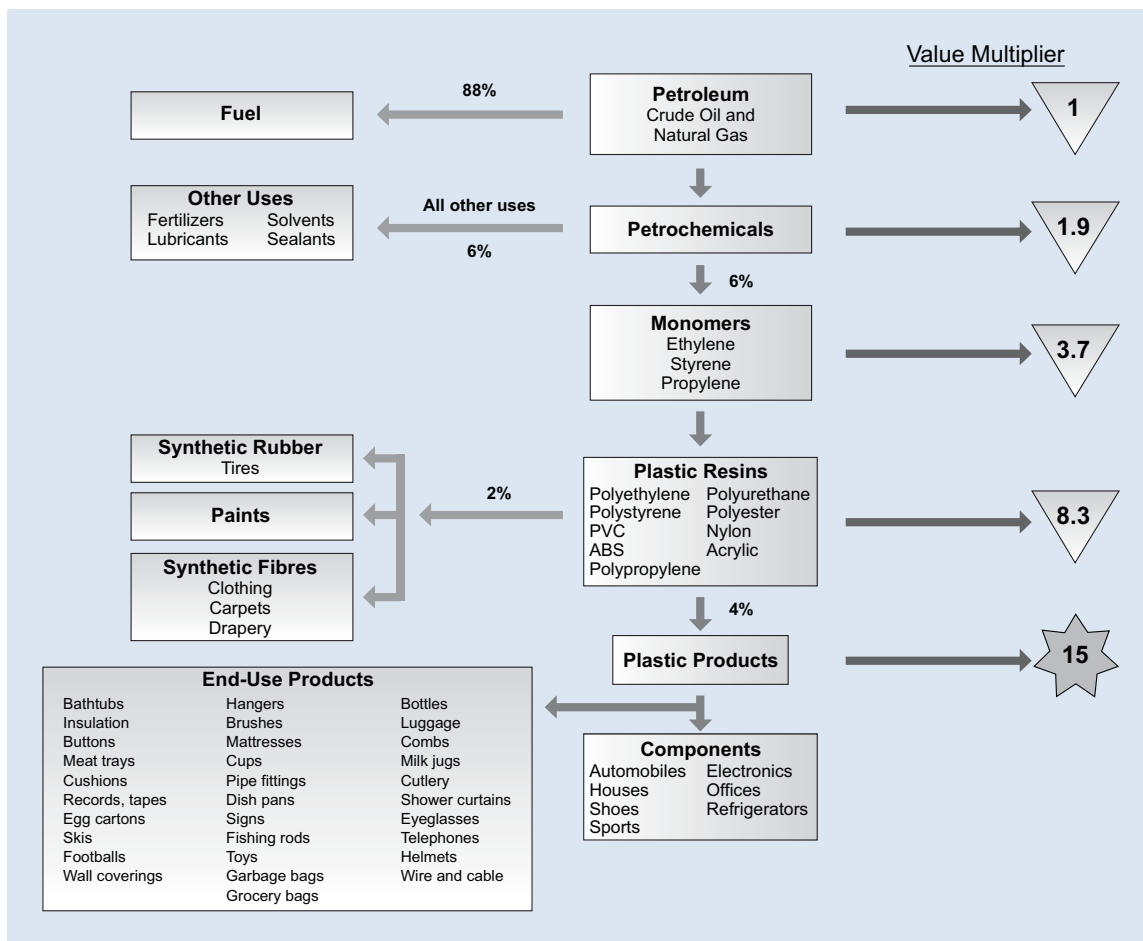

2.3 CURRENT ECONOMIC STATUS

Historically, many Canadian plastics manufacturers have been at a disadvantage to U.S. producers with larger and more concentrated local markets. The smaller production runs led to higher unit costs. For some bulky products, such as plastic piping, blown bottles or beverage crates, high shipping costs have forced producers to set up operations to serve regional markets. Most of Canada's plastics processors are located close to their customers in areas of high population density.

As a result of tariff reductions under the Free Trade Agreement (FTA) and North American Free Trade Agreement (NAFTA), there has been some rationalization of end-use industries. Certain traditional customers for plastics products have moved out of Canada to the U.S. and Mexico as a result of the consolidation of production in a U.S.-owned firm or the availability of lower Mexican assembly costs for labour-intensive products. NAFTA had a modest incremental impact that resulted in some customers looking outside of Canada for auto-related components and for lower value-added products. These losses have been offset by, among other factors, the general strength of the Canadian automotive assembly sector and the trend to just-in-time procurement that encourages parts manufacturers to locate near assembly plants.

According to Industry Canada data on the plastics industry, the trade balance for Canadian plastics products, which was a deficit for the first half of the 1990s and became a surplus in 1995, has grown to \$2.65 billion by the year 2004, as shown in Figure 2-3.

Figure 2-3 Canadian Trade Balance in Plastic Products (CAD\$)

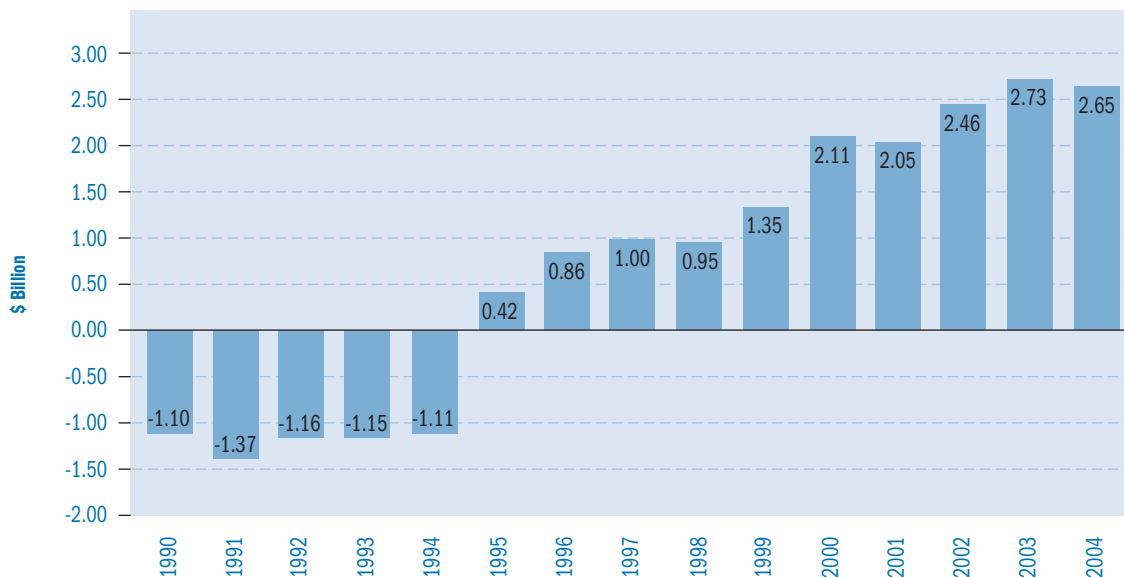

Source: CPIA

Export sales have risen in recent years (Figure 2-4) as the trade surplus increased by 20 percent since 2000.

Figure 2-4 Canadian Trade in Plastic Products with all Countries (CAD\$)

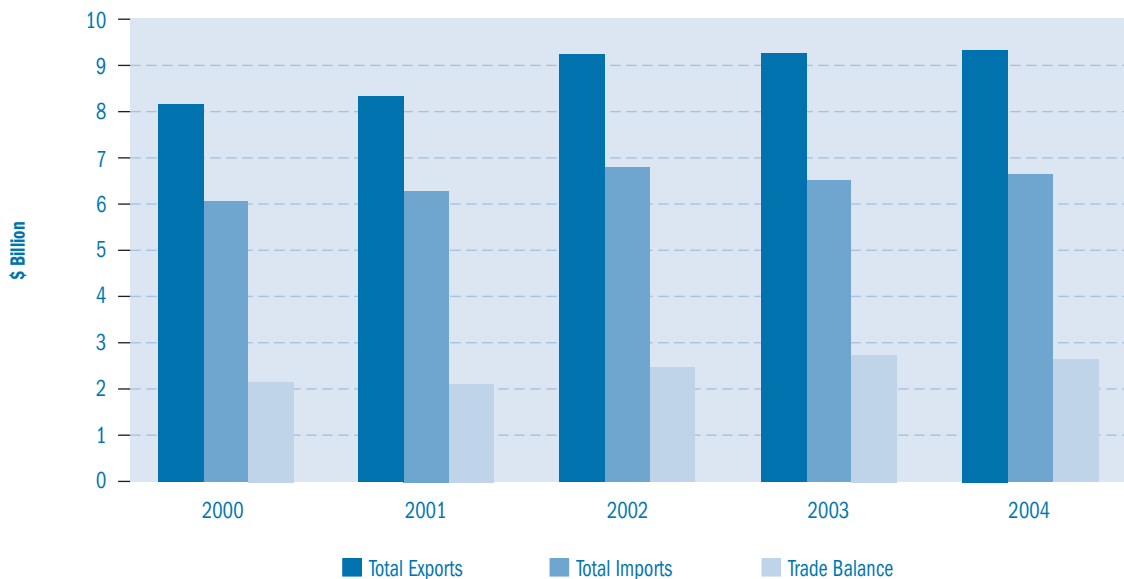

Source: CPIA

Trade with the U.S., which represents more than 90 percent of Canadian plastic products exports, increased by approximately 15 percent over the past five years, while imports from the U.S. have remained relatively constant with only a 1 percent increase (see Figure 2-5). This trend has resulted in a trade surplus growth of 43 percent for the period between 2000 and 2004.

Figure 2-5 Canadian Trade in Plastic Products with the United States (CAD\$)

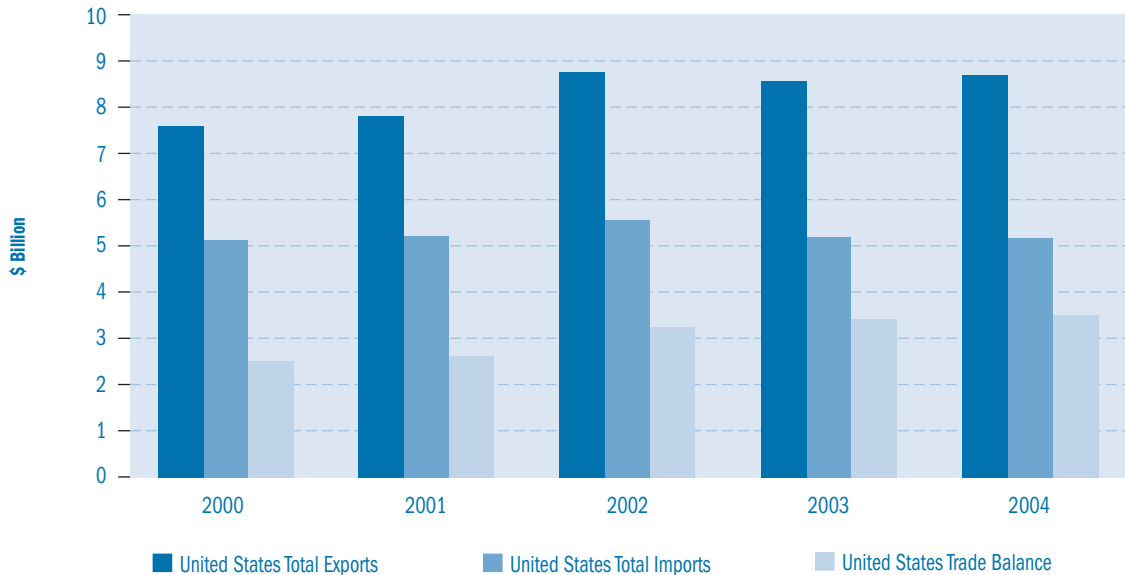

Source: CPIA

Industry observers contend that Canadian plastic processors are well-positioned to grow and compete on an international level in the coming years. The trade data show growth in trade surplus with all countries, but when the trade surplus with the U.S. is removed, Canada is in a trade deficit situation.

2.4 RESOURCE USAGE

The significant categories of resource usage by the plastics processing sector are discussed below. The use of raw materials, usually the single-largest cost factor in a plastics processing operation, is often difficult to track and manage effectively. Overall energy, water and solid waste disposal costs are readily identified in utility and waste management bills. However, many plants have little detailed knowledge of associated unit costs by specific machines or processes.

2.4.1 MATERIALS

2.4.1.1 Resins

For most manufacturers in this sector, raw materials are the single-largest operating cost. In some operations with high throughputs, such as profile extrusion, it is not uncommon for material purchases to exceed 70 percent of manufacturing expense. Typically, direct labour constitutes 5 to 15 percent of the expense, while total energy costs are often less than 5 percent.

Raw materials include resins, UV stabilizers, pigments, lubricants and other processing aids and additives. This guide focuses primarily on firms that receive thermoplastic resins in pellet form and does not specifically address operations that compound raw materials. Pellets are routinely shipped in containers ranging from 25-kg bags to 500-kg gaylords, to even larger truck or rail car shipments for high-volume producers. Improvements in the handling, processing and recycling of raw materials represent a significant savings opportunity in this sector.

Numerous types of resins are used. Material suppliers constantly increase the range of options available by developing new materials targeted at specific applications. The estimated consumption of resins (by major type) in North America is provided in Figure 2-6.

Figure 2-6 Estimated North American Consumption of Major Plastic Resins

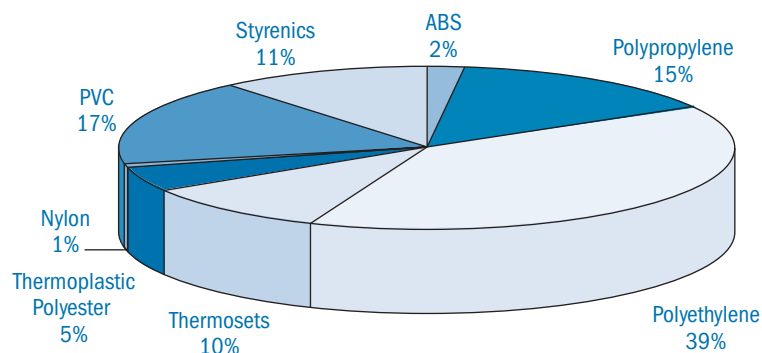

Sources: CPIA; SPI Committee on Resin Statistics as compiled by Association Services Group, LLC

2.4.1.2 Other Supplies

Plastics processing facilities use a wide range of plant supplies related to equipment and plant maintenance. Other supply categories related to specific processes and secondary operations are also used.

Typical supply categories include the following:

- **Hydraulic oil:** used to power process machinery. While the oil does not typically need to be replaced frequently, losses through leaks and hose breakages may occur.
- **Tool room supplies:** cutting oils, solvents and greases.
- **Processing supplies:** some processors add pigments or dyes, and some moulding operations also use mould releases.
- **Plant cleaning supplies:** plant cleaning supplies include soaps, detergents and absorbent materials for cleaning up oil spills.
- **Packaging and distribution materials:** bags, gaylords and pallets. Shipments of finished goods may be made in any or all of the following forms: cartons, plastic bags and/or wooden crates.

2.4.2 ENERGY

Detailed estimates of the distribution of energy demand for typical extrusion, injection moulding, blow moulding and blown-film plants were developed in 1993 for the former Energy Mines and Resources Canada (now Natural Resources Canada) by Power Smart Inc. of Vancouver. These data are summarized in Figures 2-7 to 2-9 for four generic processes: 1) extrusion, 2) injection moulding, 3) blow moulding and 4) blown film.

The estimates illustrate the relative importance of energy demand by the processes and auxiliary equipment as a proportion of the total facility demand. Furthermore, details of the total process demand are provided to assist manufacturers in identifying priority areas for energy-reduction projects.

Figure 2-7 Estimate of Plant Energy Distribution from Selected Plastic Processes – Extrusion

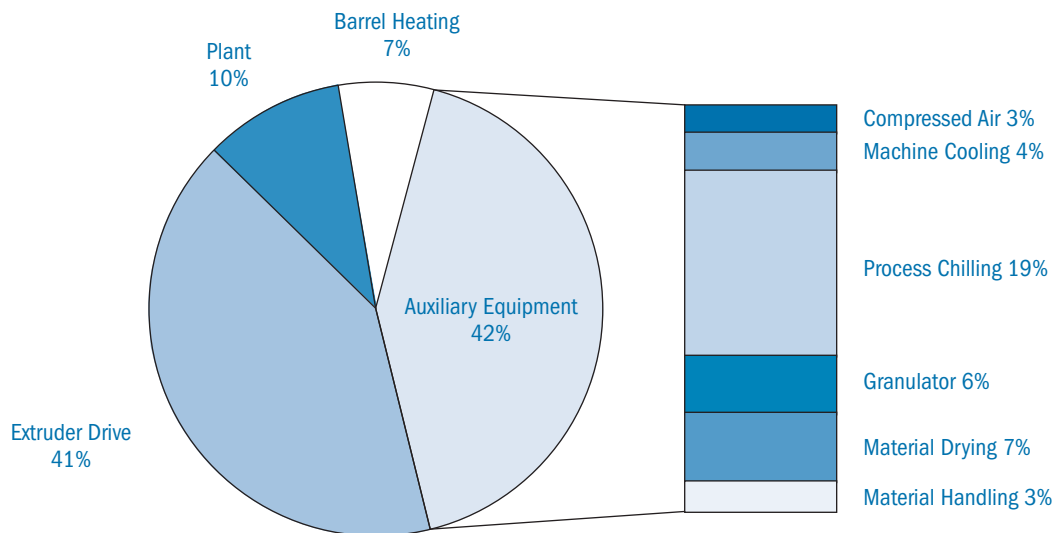

Source: Power Smart (1993)

Figure 2-8 Estimate of Plant Energy Distribution from Selected Plastic Processes – Injection Moulding

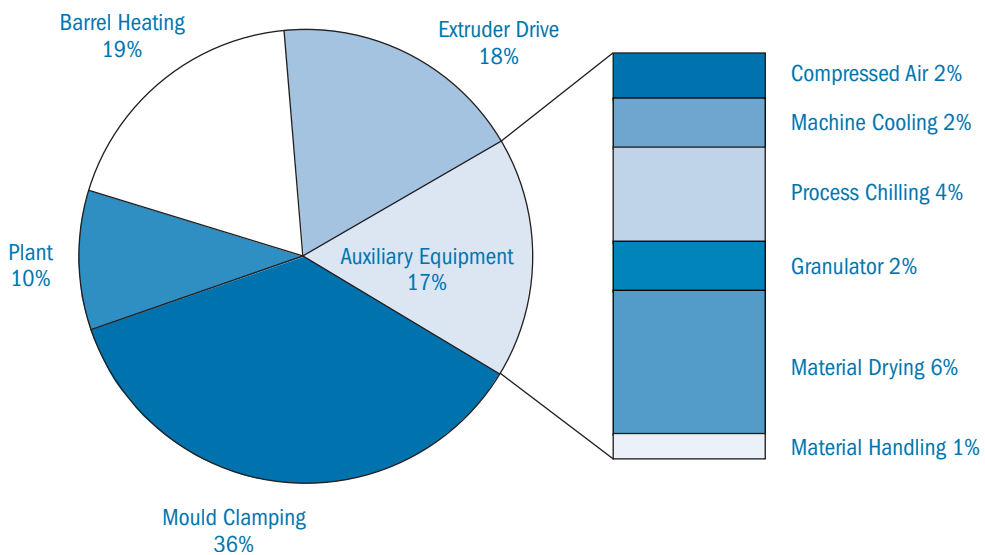

Source: Power Smart (1993)

Figure 2-9 Estimate of Plant Energy Distribution from Selected Plastics Processes – Blow Moulding and Blown Film

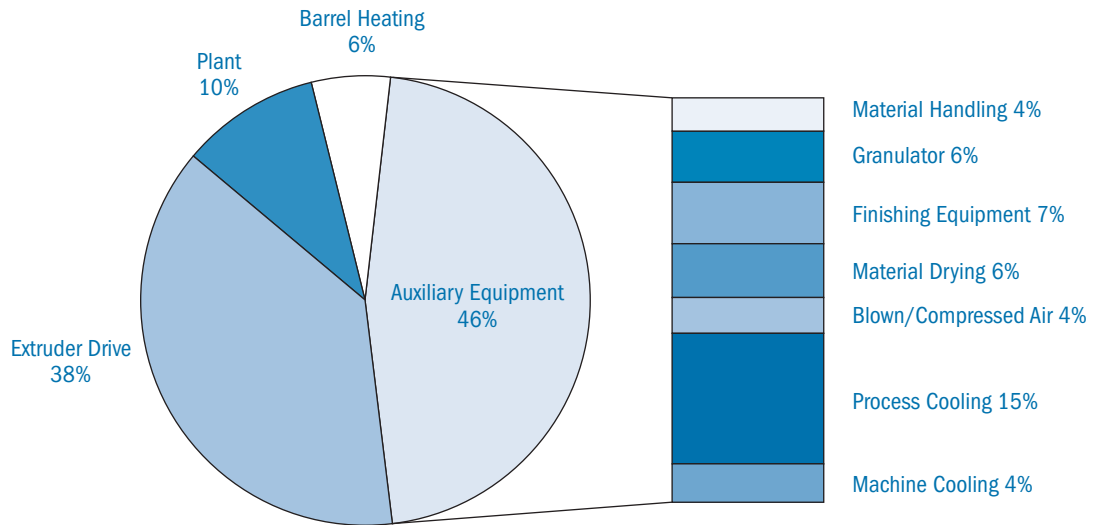

Source: Power Smart (1993)

2.4.2.1 Electricity

Electricity is the main source of energy used by plastics processors. The main uses of electricity include such applications as providing heat to extruder barrels through resistance heaters and energizing extruder drives. Electricity is also used indirectly by providing the power source for hydraulic, chilling, thermal-oil heating and compressed-air systems. Air conditioning, ventilation and lighting for the facilities are still more uses of electricity. Electrical costs account for approximately 3 to 4 percent of the production cost.

2.4.2.2 Natural Gas

Natural gas is used primarily for heating water and facilities. Other applications that can use natural gas include rotational moulding, pellet dryers and internal combustion engines, which can in turn power air compressors, hydraulic systems or electrical generators. Natural gas costs account for approximately 1 to 2 percent of the production cost.

2.4.3 WATER

Water is used for a variety of applications such as a cooling medium for profile extrusions and process-machinery components such as moulds and extruder barrels. Water is also used for cooling auxiliary equipment such as hydraulic and compressed-air systems. Water use varies widely by plant and by process.

Some smaller processors use line water in a once-through application, discharging to sanitary and/or storm sewers. Larger processors sometimes require significant volumes of cooling water and also need to control water temperature. In such cases, closed-loop water-cooling systems are preferred. Water can be recirculated and cooled using portable or permanent chillers or cooling towers.

Most plastics processors recognize that it is cost-effective to install recycling systems for process-cooling water. In addition to conserving the resource and saving money, the ability to control water temperatures allows processors to improve product quality and throughput efficiency. Environment Canada estimated in 1991 that 87 percent of water used by the plastics processing sector was being recycled. Discussions with industry leaders indicate that this number has probably increased since 1991, although no specific reference or number was available.

2.5 PROCESS RESIDUALS

Plastic processors generate various types of wastes and releases to the environment that in many cases can be reduced. Plastic materials, when processed under conditions specified by the manufacturers, are relatively stable and do not present a significant risk to humans or the environment. Cost savings may be achieved, however, by reducing waste and emissions, especially by improving the management of raw material losses due to inefficiencies.

2.5.1 AIR RESIDUALS (GASES AND DUST)

Air emissions from plastics processing include volatile organic compounds (VOCs), dust and carbon dioxide (a greenhouse gas). The following sections provide a brief description of VOCs and dust emissions from plastics processing. Greenhouse gas emissions are covered separately in Chapter 3.

2.5.1.1 Volatile Organic Compound (VOC) Emissions

VOCs are emitted from some plastics-manufacturing processes. VOCs contribute to the generation of ground-level ozone – a major component of smog.

The major source of VOC emissions in plastics processing results from the following:

- degradation of resin;
- blowing agents used for expanded foam products;
- additives;
- cleaning solvents; and
- mould-releasing agents.

The four generic processes that account for approximately 60 percent of the VOC emissions in the plastics processing sector are the following: 1) reinforced plastic and composite products made from thermoset polyester resins, 2) extruded polyethylene [PE] foam, 3) expanded polystyrene [EPS] foam and 4) polyvinyl chloride [PVC].

A Plastics Processing Working Group was formed in 1997 in response to the Ontario's Smog Plan issued by the Ontario Ministry of Environment. The group's purpose was to address VOC emissions in the four processes identified above.

VOC emission estimates for each of the processes are presented in Table 2-2.

Table 2-2 Volatile Organic Compound (VOC) Emission Estimates

Process	Resin Consumption (tonnes processed per year)			VOC Emission Estimates (tonnes VOC/year)		
	1990	1997	% change from 1990	1990	1997	% change from 1990
Composites	15,085	14,860	-1.5%	1,347	1,143	-15%
PE Foam	2,600	3,700	+42%	149	355	+138%
EPS Foam	16,740	12,244	-27%	1,023	711	-30%
PVC	TBD	TBD		TBD	TBD	
TOTAL	34,425	30,804	-10.5%	2,519	2,209	-12.3%

The following are highlights of the VOC emission reductions achieved between 1990 and 1997 for each process sub-group.

Composites: VOC emissions were reduced by an estimated 15 percent in 1997 from 1990, while resin consumption remained essentially the same during the period. This reduction was achieved due to two main factors: First, a significant switch in process technology from open moulding to closed moulding took place (as a proportion of resin

consumption, the use of open moulding declined from 80 percent in 1990 to 70 percent in 1997). With the move to closed moulding, VOC emissions have been reduced because of the lower losses of styrene associated with closed-moulding operations. VOC emission factors are estimated to be 5 percent for closed moulding as opposed to 22 percent for open moulding based on the weight of available styrene. The second factor for the achieved reduction in VOCs was due to a decrease in styrene content of supplied resin, from 48 percent in 1990 to 45 percent in 1997.

PE Foam: VOC emissions in 1997 were more than double those in 1990. The main reason is that the percentage of blowing agent used in blowing increased from 5.7 to 9.6 percent of foam produced. This was due to the switch from CFCs and HCFCs to butane as a blowing agent. As well, the increase in production rates of 42 percent also contributed to the increased emissions.

EPS Foam: VOC emissions were reduced by an estimated 30 percent in 1997 from 1990. The 30 percent decrease in emissions was largely due to a decline in Ontario resin consumption. This decline was the result of the loss of plants from Ontario. Another factor was a decline in the VOC content of the supplied resin from 6.11 to 5.81 percent by weight.

PVC: Actual reductions achieved from 1990 have not been estimated.

For more detailed information on VOC emission reduction work in the Ontario plastics processing industry, please refer to the *Ontario's Smog Plan – Progress Report of the Ontario Plastic Processors Working Group* (November 1999).

2.5.1.2 Dust

Some plastics processing operations are also known to emit airborne dust particles. Material handling, blending and grinding operations have the potential to generate dust. High levels of dust may create an explosion hazard. Efforts to minimize dust are also encouraged to further reduce employees' exposure to respiratory risk associated with exposure to airborne particles.

2.5.2 WASTEWATER AND LIQUID WASTES

Non-contact cooling water may be used for machinery-, mould- or auxiliary-equipment cooling prior to sanitary sewer system discharge. Potential contaminants include particulates such as pellets, hydraulic or lubricating oils, and solvents.

Liquid wastes that require special handling and are commonly generated by the plastics processing industry include used hydraulic oils, spent solvents and other chemicals.

2.5.3 SOLID WASTE

The solid waste stream from plastics processing operations typically includes packaging materials such as bags, gaylords and skids, purgings from machine start-ups, degraded material and unsalvageable scrap. Pellets that have been spilled and raw materials that have been contaminated by mixing or by foreign matter may also become solid waste destined for disposal.

Other wastes not specifically related to the process include office waste, waste paper, corrugated packaging, cafeteria/lunch room food wastes, bottles and cans, and landscaping wastes.

2.5.4 NOISE

Hydraulic pumps, scrap grinders, sonic welders, and material handling and conveying equipment are all considered to be common sources of objectionable noise. Excessive noise levels can result in unpleasant working conditions. It may be necessary to control noise levels to prevent exceeding the limits set out by the *Occupational Health and Safety Regulations*.

Plant noise that affects neighbouring residential, commercial or industrial operations is regulated by municipal noise control by-laws. Noise sources that may exceed limits and give rise to neighbourhood complaints can include material-handling techniques, such as the emptying of tank trucks or rail cars.

2.6 ENVIRONMENTAL LEGISLATION

Many responsible processors seek to achieve environmental performance that would exceed compliance with environmental legislation. A variety of environmental legislation is of interest and could pertain directly to the plastics processing sector. The legislation is intended to protect the environment from all potential discharges to the air, water and land. Specific regulations vary by province/territory, but the key areas of relevant legislation for plastic processors include the following:

- air emissions – particulates, odours, ozone-depleting substances and greenhouse gases;
- effluent discharges – direct discharges to receiving bodies and discharge to sewers;
- solid wastes – hazardous and industrial wastes; and
- recycling.

3

GREENHOUSE GAS EMISSIONS FROM THE PLASTICS PROCESSING INDUSTRY



3. GREENHOUSE GAS EMISSIONS FROM THE PLASTICS PROCESSING INDUSTRY

3.1 INTRODUCTION

Climate change is an important global topic, and the connection between atmospheric concentrations of greenhouse gases, air pollution, atmospheric warming and specific weather events is very complex. The potential risks associated with climate change are significant enough that reducing greenhouse gas emissions is necessary.

This chapter provides background information on the relationship between energy consumption, plastics production and greenhouse gas emissions, and what is being done to deal with this important issue.

3.1.1 GREENHOUSE GASES

There are six principal greenhouse gases. The list of gases and their global warming potential are indicated in Table 3-1.

Table 3-1 Greenhouse Gases

Greenhouse Gas	Abbreviation	Global Warming Multiplier
Carbon dioxide	CO ₂	1
Methane	CH ₄	21
Nitrous oxide	N ₂ O	310
Hydrofluorocarbons	HFCs	140–11,700
Perfluorocarbons	PFCs	6,500–9,200
Sulphur hexafluoride	SF ₆	23,900

Greenhouse gas emissions are generated primarily as a result of energy consumption in the plastics processing industry. There are minor quantities of HFCs emitted from the extruded polystyrene and polyurethane foam-production process that will be discussed in a later section.

3.1.2 ENERGY AND GREENHOUSE GAS EMISSIONS

As mentioned above, greenhouse gas emissions are generated primarily as a result of energy consumption in the plastics processing industry. The significant growth that the plastics processing sector has experienced over the past decade has been accompanied by a growth in energy consumption and associated greenhouse gas emissions. The Canadian Plastics Industry Association, in cooperation with the Canadian Industry Program for Energy Conservation (CIPEC), commissioned a Review of Energy Consumption and Related Data (CIEEDAC, 2005), which highlights some of the difficulties in obtaining an accurate representation of energy efficiency and emissions intensity of the Canadian plastics industry. The major limitations to the data for the plastics industry are related to the differences in sector population definition and the fact that production data are not readily available for the sector to estimate energy performance trends. In spite of these limitations, the following section provides a brief summary of the energy consumption trends for the sector and an estimate of the energy efficiency performance of the sector for the period from 1999 to 2004.

The two primary forms of energy used by the plastics processing industry are electricity and natural gas. As indicated in Chapter 2, electricity is the main source of energy with electrical costs accounting for 3 to 4 percent of the cost of production. Electricity is used to provide heat to extruder barrels and to energize extruder drives. Electricity is also used as a power source for hydraulics, chilling, heating and compressed air, and for providing ventilation, air conditioning and lighting for the building. Natural gas costs can account for approximately 1 to 2 percent of the cost of production. Natural gas is primarily used for heating water and facilities, but can be used in many other applications within the plastics-manufacturing process.

The total energy consumed by the Canadian plastics processing sector (as defined by NAICS 3261) for the period from 1999 to 2004 is presented in Figure 3-1. The sector gross domestic product (GDP) is also shown in Figure 3-1, which gives an indication of the growth of the sector for the same period.

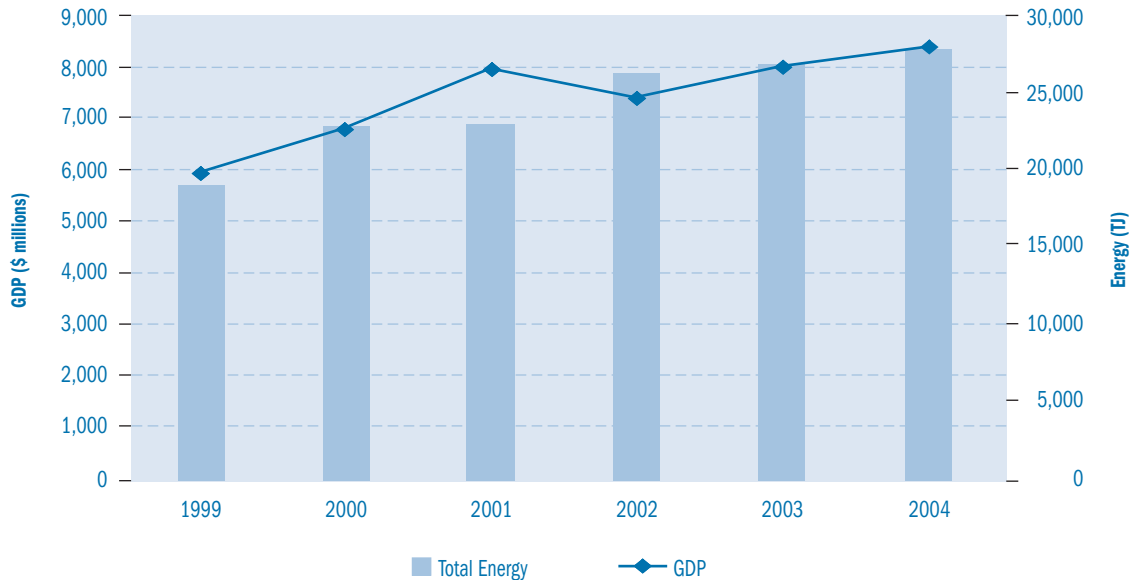
Figure 3-1 Canadian Plastics Processing Sector Energy Consumption and GDP

For the six-year period 1999–2004, the total energy consumed in the plastics products industry increased 36 percent from 19,950 terajoules to 27,050 terajoules. For that same period, GDP increased by 46 percent from \$5.7 billion to \$8.4 billion.

3.1.2.1 Greenhouse Gas Emissions Performance

Greenhouse gas emissions are considered as either direct emissions, as a result of combustion of fuel at the plastics processing facility, or indirect emissions, as a result of fossil-fuel combustion required to generate the electricity used by the plastics processing facility. The factors used to estimate the emissions of CO₂, CH₄ and N₂O resulting from the combustion of natural gas (which represents approximately 85 percent of the plastics product sector direct emissions) are shown in Table 3-2.

Table 3-2 Emission Factors from Natural Gas Combustion

Gas	Emission Factor (g/m ³ fuel)
CO ₂	1880
CH ₄	0.0048
N ₂ O	0.02

The CH₄ and N₂O emissions are minor compared to the CO₂ emissions. The convention of reporting greenhouse gas emissions on a CO₂-equivalent basis will be used throughout this report.

Canadian plastics products processors should be concerned with the greenhouse gas emissions performance of their operations, or the emissions per unit of production. On a Canadian aggregate basis, there are no data available to measure the production levels annually, but, as shown in Figure 3-1, the GDP can be used as an approximation. This is useful to get a sense of the performance trend, but could be skewed by disproportionate increases in price of products and other monetary factors.

By improving energy efficiency, plastics processors can reduce both direct emissions (from consuming fossil fuels on site) and indirect emissions (associated with electricity generation off-site). Indirect-emissions intensity will be influenced by the form of electrical generation (i.e. thermal versus hydropower), which will vary significantly between provinces/territories, and will not be within the control of the plastics processors. The direct emissions are most relevant and controllable by the plastics processing facilities. The trend in direct emission performance, as a function of GDP, is presented in Figure 3-2 based on data from the Canadian Industrial Energy End-Use Data Analysis Centre (CIEEDAC) for Canada, for the 1999–2004 period.

Figure 3-2 Canadian Plastics Products Industry Greenhouse Gas Emissions as Percentage of GDP – Plastic and Rubber Products Manufacturing

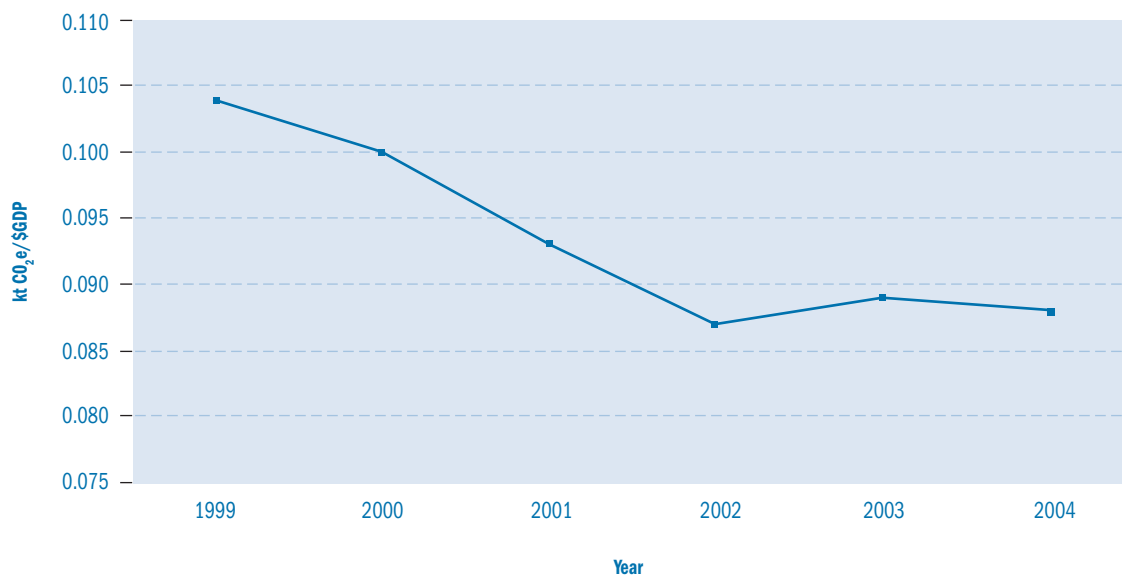

As shown in Figure 3-2, direct greenhouse gas emissions as a percentage of GDP have been stable for the past three years but, overall, have decreased by 15 percent since 1999.

3.1.3 HYDROFLUOROCARBON EMISSIONS FROM PLASTICS PROCESSING

Hydrochlorofluorocarbons (HCFC) and hydrofluorocarbons (HFC) are used as blowing agents in the production of extruded-polystyrene and polyurethane foams. The use of HFCs in plastics processing globally is currently on the rise as the greenhouse gas HFC is used as a replacement for the ozone-depleting HCFCs. The use of HCFCs or HFCs in the Ontario plastics processing sector is minor, with only three companies reporting HCFC emissions in the National Pollutant Release Inventory (NPRI) database (companies are not required to report HFCs to the NPRI program).

Specific data on HFC emissions are not available and much of the work in evaluating alternatives to the use of these compounds is proprietary. Canada's Greenhouse Gas Inventory estimates that 10,000 kilotonnes of CO₂-equivalent HFCs were emitted from foam blowing in Canada in 1997. There are no data available to estimate the HFC emissions from Canadian plastics processing, and therefore it is not possible to determine if HFC emissions in Canada are increasing or decreasing. In discussions with one Canadian plastics processor, it was reported that it had successfully eliminated the use of HCFCs and HFCs from its production. Further references for more information on HFC use in plastics processing are provided in Chapter 9.

3.2 OPPORTUNITIES FOR REDUCING GREENHOUSE GAS EMISSIONS

Direct emissions from plastics processing in Canada are small (less than 1 percent) in relation to discharges from other manufacturing activities in Canada. Direct emissions have increased by 8 percent since 1999, but emission intensity has decreased by 15 percent as shown in Figure 3-2.

Both direct and indirect greenhouse gas emissions can be reduced through ongoing improvements in energy efficiency at any given plastic processing facility. Investments in energy-efficient technologies and capital upgrades must make financial sense if plastics processors are expected to make such investments.

The rate of investment in energy efficiency is determined to a large degree by the following two factors:

1. **Age, capability and depreciated value of the existing capital stock** – the average service life of machinery and equipment for the plastics product industry is 13 years. It is not uncommon for small operations to be using equipment in the 20- to 30-year age range.
2. **Rate of return expected on investment in new technology and equipment** – currently, the amount of investment generated from energy savings alone falls short of covering the capital costs of replacing existing equipment with highly energy-efficient equipment.

Information on energy efficiency programs and resource material is provided in Chapter 9.

Plastics Help Reduce Greenhouse Gas Emissions from Automobiles

As automakers continue to look for ways to reduce vehicle weight, to reduce costs and to improve fuel economy, a related benefit is a reduction in greenhouse gas emissions per kilometre driven. Here are just a few examples:

- *The 2001 Chevrolet Silverado used reinforced-reaction injection-moulded (RRIM) plastic fenders and a structural-reaction injection-moulded (SRIM) composite cargo box to make the truck's total weight 25 kilograms lighter than with conventional steel components.*
- *The 2001 Chevrolet full-size and heavy-duty pickups have RRIM rear fenders saving 30 kilograms of weight.*
- *DaimlerChrysler and Ford Motor Co. introduced plastic rear bumpers on selected models. This was the first non-metallic rear bumper in its class, and the bumper system is 41 percent lighter than its steel counterpart.*

Greenhouse gas emissions from passenger automobiles and light trucks continue to grow, as more vehicles are driven more kilometres. With more than 31,000 kilotonnes of CO₂ emissions from this sector, representing approximately 16 percent of Ontario's total greenhouse gas emissions, every incremental reduction will have an impact.

Reference:

www.findarticles.com/m3012/10_180/0/p1/article.jhtml

3.2.1 CANADIAN INDUSTRY PROGRAM FOR ENERGY CONSERVATION

The Canadian Industry Program for Energy Conservation (CIPEC) is a national program that “promotes effective voluntary action that reduces industrial energy use per unit of production, thereby improving economic performance while participating in meeting Canada’s climate change objectives.” CIPEC is composed of sectoral task forces, each of which represents companies engaged in similar industrial activities.

CIPEC works through its Task Force Council to establish sectoral energy-intensity improvement targets and publishes an annual progress report.

Plastics Energy and Greenhouse Gas Savings Using House Wrap

A case study prepared in 2000 for the American Plastics Council and the Environment and Plastics Industry Council (EPIC) of the CPIA demonstrated the greenhouse gas reduction benefits associated with applying a plastic house wrap to the exterior of single-family residential housing in the U.S. and Canada. The life cycle analysis methodology demonstrated that a CO₂-equivalent reduction of between 360 and 1,800 kilograms could be achieved by reducing energy use for a typical Canadian house on an annual basis. The study also reported that if all of the houses built in Canada during the period 1991–1995 had been built with house wrap, the estimated reduction in energy-related greenhouse gas emissions for Canada would be 1.8 to 8.2 million metric tonnes of CO₂ equivalent over the same period.

Reference: www.plasticsresource.com

3.3 SUMMARY

Energy use by the plastics processing industry in Canada has increased by 36 percent over the 1999–2004 period. Plastics production increased by 46 percent over the same period. The resulting energy intensity (energy per unit production) has improved by 15 percent over the six-year period. These numbers indicate that energy efficiency improvements have been made by the plastics processing sector and that greenhouse gas emissions per unit of production have decreased.

Discussions with Canadian plastics processors have indicated that there are many opportunities for increasing energy efficiency and decreasing greenhouse gas emissions, which will be implemented when the economic factors (payback, rate of return) are favourable. Programs or specific tools that would assist plastics processors in assessing energy efficiency opportunities would be of value to the sector and would help the greenhouse gas reduction efforts.

Further study is required to determine what tools would be most effective in facilitating energy efficiency improvements.

4

GENERIC PROCESSES, PRODUCTS AND PRODUCT MARKETS



4. GENERIC PROCESSES, PRODUCTS AND PRODUCT MARKETS

Plastics manufacturing processes covered by this guide include the significant, high-volume methods for processing thermoplastic materials. Two of the major thermoset processes are also discussed. Industry estimates suggest that the processes listed below capture approximately 90 percent of the sector activity. Descriptions and illustrations of these generic processes can be found in Chapter 5.

Manufacturing operations will benefit from a review of the material presented in this guide. In addition to resource conservation opportunities for each of the primary processes listed, all plants in the sector use energy for plant space heating and cooling, material handling, secondary operations and transportation.

4.1 GENERIC PROCESSES AND TYPICAL PRODUCTS

Plastics manufacturing processes are versatile and capable of producing a wide variety of end products from a range of thermoplastic and thermoset plastic materials. The production processes listed below, along with example products, are a small sample of the applications commonly found.

Six generic thermoplastic processes constituting the majority of production include the following:

- Profile extrusion (e.g. pipe, siding, automotive trim)
- Injection moulding (e.g. containers for retail dairy products, CD cases, pipe fittings)
- Sheet extrusion (e.g. swimming pool liners)
- Injection blow moulding (e.g. soft drink bottles, jars)
- Blown-film extrusion (e.g. garbage bags, shopping bags)
- Extrusion blow moulding (e.g. detergent and lubricant bottles)

Two significant non-thermoplastic processes are also discussed:

- Compression moulding of thermoset plastics (e.g. automotive panel components, truck air deflectors)
- Urethane foam moulding (e.g. automotive seat cushions, impact-absorbing dashboard components)

There are many other plastics manufacturing processes that are not discussed in this guide. These include such processes as reaction-injection moulding, rotational moulding, casting, thermoforming, vacuum forming, pultrusion, hand lay-up and others. In addition, manufacturers perform many types of finishing and secondary operations that are also beyond the scope of this guide. A more comprehensive listing of the generic processes used in Canada are itemized in Appendix III.

4.2 USE OF PLASTIC PRODUCTS IN VARIOUS MARKET SEGMENTS

A breakdown of the use of plastics in Canada by various end markets and product types are presented in Figure 4-1. This illustration outlines the broad range of product applications and also the significance of plastics processing to the Canadian economy.

Figure 4-1 Plastic Products in Various Market Segments

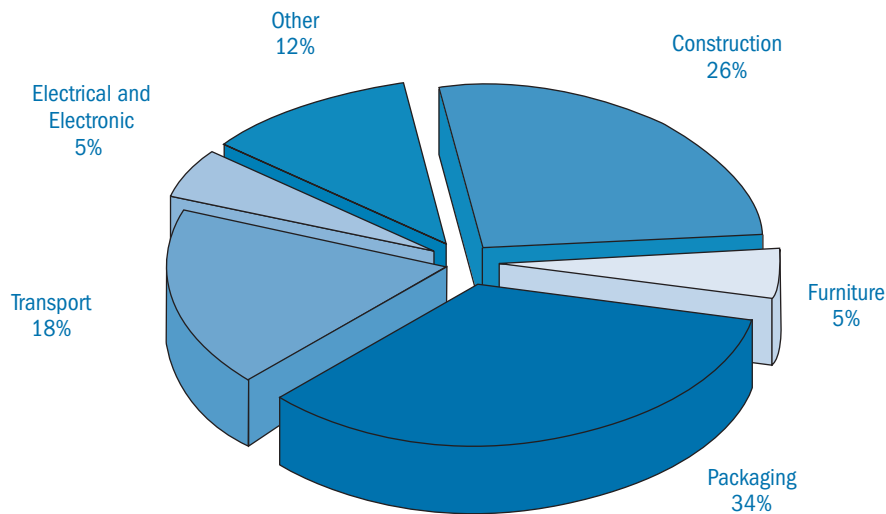

Source: CPIA

5

GENERIC PROCESSES AND AUXILIARY SYSTEMS DESCRIPTIONS



5. GENERIC PROCESSES AND AUXILIARY SYSTEMS DESCRIPTIONS

The purpose of highlighting commonly used generic processes is to pinpoint where opportunities may exist to minimize resource consumption and to reduce process discharges. Illustrations of generic processes together with process descriptions are provided in this guide. The process diagrams identify resource inputs and sources of effluents. Both the descriptions and diagrams are highly simplified and are intended to introduce the technology to readers who are unfamiliar with the industry.

Several of the processes described below may also be enhanced by feeding more than one material type, colour or grade into the process to manufacture products with layers of dissimilar materials. This enables the manufacturer to obtain improved technical-, aesthetic- or cost-benefits from a single process. In addition, robotics play an increasingly important role in enhancing repeatability in processes, as well as in reducing cost and the risk of accidents. To keep things simple, enhancements such as these are ignored throughout the process descriptions outlined in the text.

Illustrations of auxiliary systems are also provided. Examples of some of the systems illustrated include a closed-loop free-cooling water system, a compressed-air system and a pneumatic raw-material handling system. Resource consumption areas and emission points are pinpointed in each of the generic auxiliary systems described.

Readers already familiar with generic processes, process technology and auxiliary systems may proceed directly to Chapter 6, “Generic Improvement Opportunities.”

5.1 PROFILE EXTRUSION

Single screw extrusion is the most commonly used technology for profile extrusion. A thermoplastic raw material, typically in pellet form, is fed from a hopper into a barrel that houses a rotating screw. A small laboratory-sized extruder may have a screw diameter of 10 mm, while screws for high-volume extruders may have diameters in excess of 300 mm. The screw is typically driven by a variable speed electric motor that may be coupled to a single- or multi-speed gear box.

The screw system performs several functions:

- It conveys material from the hopper to a die located at the opposite end of the barrel.
- The screw plasticizes and pressurizes the material. Heat is generated by a combination of internal heating due to shear and heater bands located outside the barrel. The barrel may be vented to allow gases and water vapour to escape. Venting requires a multiple-stage screw, with a decompression zone between the compression stages.
- The screw may be used to blend in colorants and other additives.

- The control of melt temperature, homogeneity and pressure are all critical factors. Thermocouples are used to sense temperature along the barrel and to control the amperage to the heater bands. To prevent excessive shear heat from degrading the material, some barrel zones may be water- or air-cooled.

The plasticized material is forced through a die to form the desired shape. After passing through the die, the partially solidified extrudate may be further formed by callipers or vacuum sizers to achieve the final desired configuration and to maintain required tolerances. The extrudate is then water- or air-cooled. When the material has solidified sufficiently to resist damage from handling, a puller system is used to maintain a constant tension on the extrudate. Beyond the puller, a travelling saw or shearing mechanism is used to cut the product into desired lengths for shipment or further processing.

Twin extruders, with two parallel screws, are capable of high output with low shear and are typically used for large volume processing of heat-sensitive materials. Typical applications include siding and pipe produced from non-pelletized (powder) materials. Co-extrusion – the use of more than one extruder to feed a single die – is common.

Most custom operations use various sizes of general purpose extruders. However, significant productivity, quality and energy efficiencies may be achieved by using a machine matched to a specific job. For a specific material and throughput, it is important to select the appropriate screw diameter, length to diameter ratio and operating conditions.

A wide variety of thermoplastic materials may be processed by extrusion. The largest volume material is PVC (polyvinyl chloride), which is used for construction vinyl siding, sewer pipe and along windows (or lineals). ABS (acrylonitrile butadiene styrene) is used for refrigerator trim, drain pipes and furniture components.

Resource Consumption and Emissions in the Profile-Extrusion Process

The major energy requirement for this process is the electricity to drive the extruder-screw motor. Some electrical energy is used to drive puller motors and cut-off saws. In other cases, the cut-off equipment may be operated by compressed air.

Significant amounts of water may be used to cool the lineals. This water is often recirculated.

Water vapour and other gaseous emissions are released into the atmosphere from barrel vents, the feeder throat and the nozzle.

Figure 5-1 Resource Consumption and Emission Points in the Profile Extrusion Process

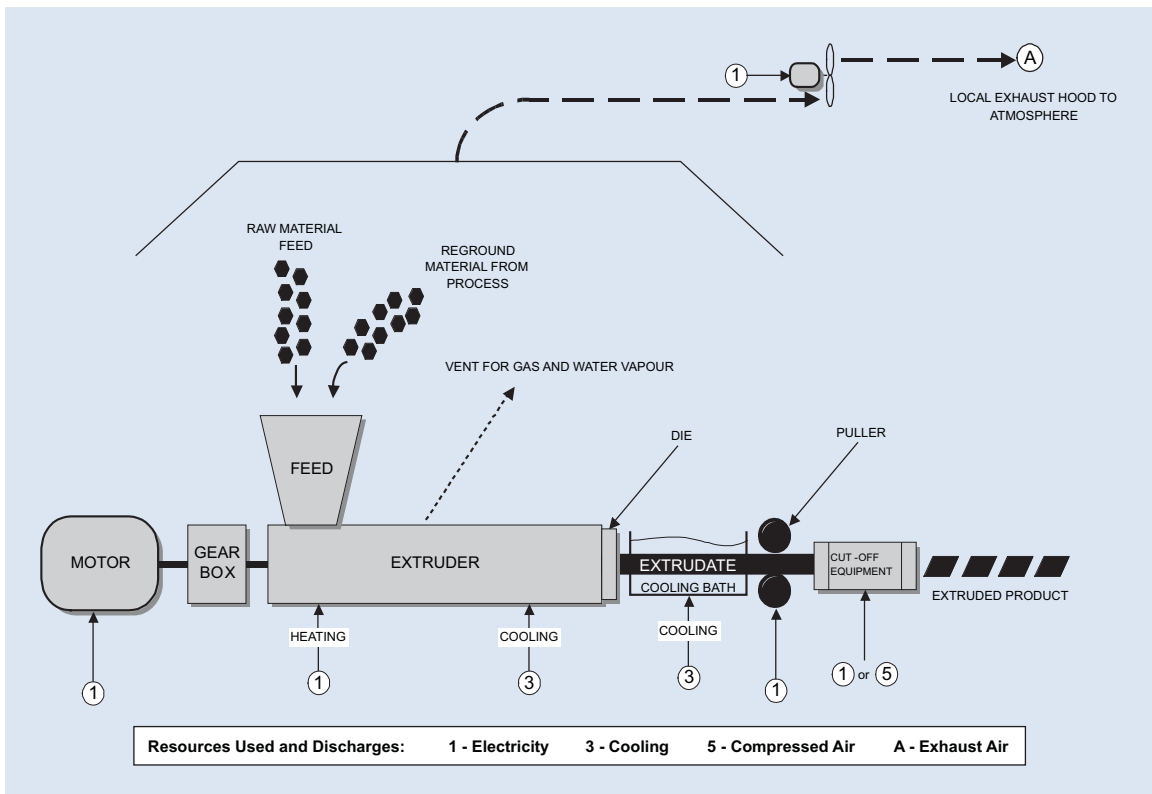

5.2 THERMOPLASTIC INJECTION MOULDING

Thermoplastic injection moulding is a versatile process used to produce a wide variety of end products. With proper tool design and material selection, injection moulded parts can provide a broad range of physical properties, decorative features and resistance to chemical attack and ageing. When required, metal inserts may be used in injection moulded parts to provide additional strength.

Injection moulding machines are commonly classified by clamp tonnage – the force required to resist the pressure exerted by the material injected into the mould during the injection process. The pressures are frequently high, 20,000–30,000 psi. As a result, clamp tonnages normally range from 20 tonnes for a small machine to 6,000 tonnes or more for a large press.

The plasticizing of the material is similar to the process described under the profile-extrusion process description. The major difference is that in the injection-moulding process, the screw retracts while it is rotating and a pre-determined amount of plasticized material accumulates in front of the screw. The screw stops rotating at this point, and the screw assembly moves forward to force the material through a nozzle into a mould under high pressure.

Cycle times vary with materials used, wall thickness of the parts and tool technology. Thin-walled containers typically have a cycle time of a few seconds. Large parts with heavy sections will take several minutes to solidify before being removed from the mould.

For parts that require trimming, 100 percent inspection or secondary operations, an operator manually removes the parts from the mould. Alternatively, the parts may be allowed to fall into a container, or robots (sprue pickers) may be used to remove the sprues and/or parts from the mould. In more sophisticated applications, robots are used to package the parts or to transfer them to a secondary operations station.

Various options exist for feeding the material into the mould cavities. The conventional method is to feed material through a sprue and a runner system into one or more mould cavities. After the part has solidified, the mould opens and the parts may be trimmed from the runner system. In most applications, the sprues and runners are reground and fed back into the process.

Various levels of sophistication in tool technology help reduce the labour and energy required to trim parts after moulding. For example, tunnel or submarine gates are used to separate the part from the runner system during the mould-opening sequence.

The effort to separate and re-grind runners may be totally eliminated by using a hot-runner system. Heaters built into the mould keep material in the runners in a molten state until the next shot. Although hot-runner tooling is more costly, the technology is commonly used for high-volume small parts, especially when heat-sensitive materials are used. With conventional tooling, the runner-to-part weight ratio is typically quite high, and materials may become degraded by passing through the heating cycle several times.

Injection moulding is used to process a broad range of materials. Commodity resins, such as polyethylene, are found in ice cream tubs and polystyrene is found in CD cases.

When the end-use requires physical or chemical properties that are not available in commodity grades, engineered plastics are used. Nylon, for example, is frequently used in applications that require toughness and lubricity. Some ABS parts, such as faucet handles and automotive trim, are electroplated for decorative and functional applications.

Resource Consumption and Emissions in the Injection-Moulding Process

The major energy requirement for this process is the electricity to power the hydraulic systems. The majority of the energy is used to plasticize the material, with lesser amounts required for injection and to transport the moulds.

The moulds are usually water-cooled. This water is typically recirculated.

Water vapour and other gaseous emissions are released into the atmosphere from barrel vents, the feeder throat and the nozzle. Mould releases, if used, will also contribute to air emissions. Mould cooling water is typically recirculated. Leaks from the hydraulic systems may contaminate plant wastewater.

Figure 5-2 Resource Consumption and Emission Points in the Injection-Moulding Process

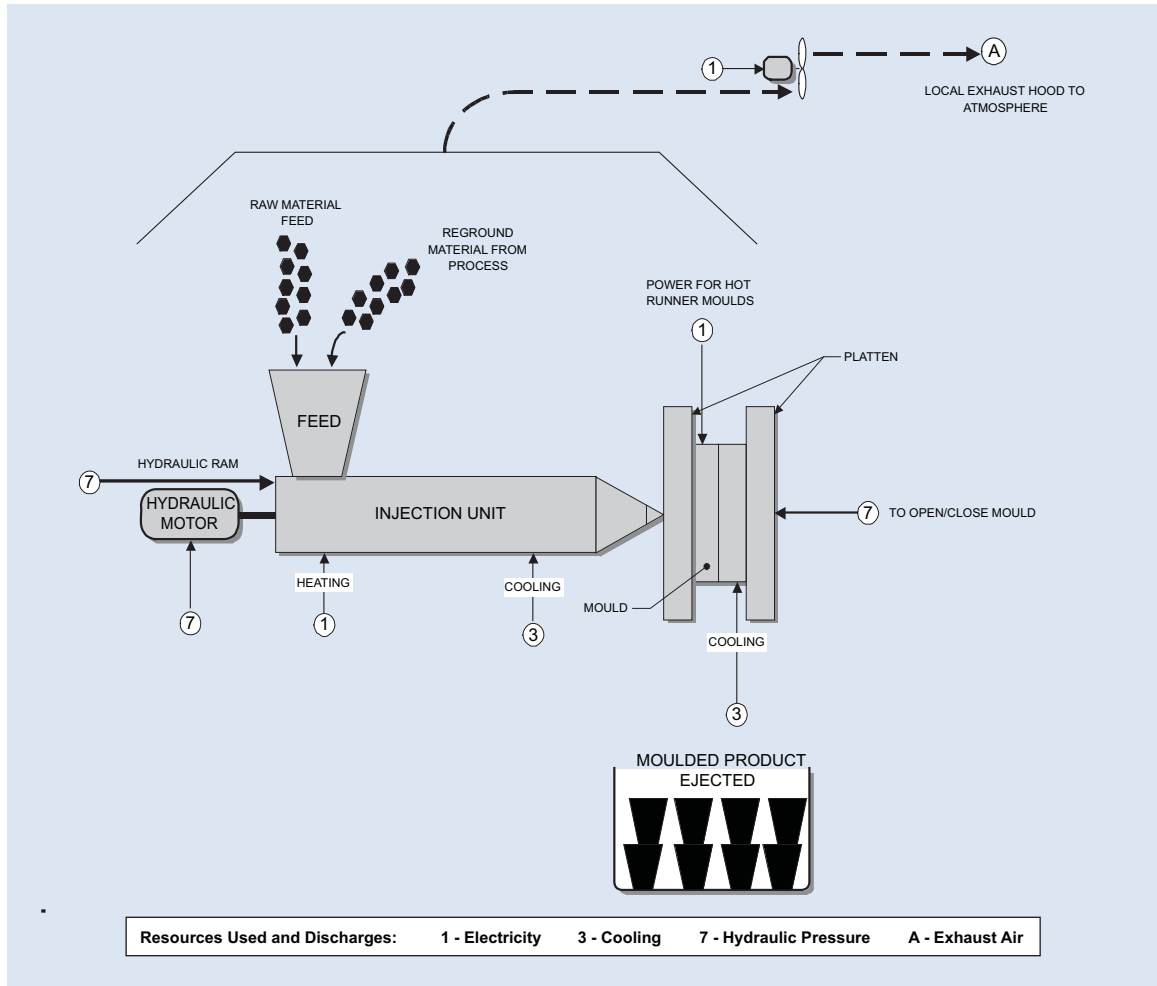

5.3 FLAT FILM OR SHEET EXTRUSION

In this process, a slot die, often three to four metres wide, is mounted on an extruder to produce a film. This film is typically fed vertically into a cooling bath and is passed over chilled rolls. The highly polished rolls produce a smooth flat film surface that has excellent clarity. Film thickness is partially a function of the cooling rate. Accurate temperature control of the rolls and cooling baths is important.

The roll mechanism is run at a speed that stretches the film, while reducing its thickness. This process produces a film that has superior physical properties in the direction of the stretch and lower properties across the film. Biaxially oriented film with good strength in all directions may be obtained by stretching the extruded film both longitudinally and transversely.

Sheet may be produced with a wide range of thicknesses, from thin film for packaging applications to heavier gauges used by whirlpool tub manufacturers. Sheet may be co-extruded from more than one type of material and may be supplied with embossed surfaces.

A wide range of polymers may be processed by sheet extrusion; polyethylene, polypropylene and polystyrene are commonly used.

Resource Consumption and Emissions in the Flat-Film or Sheet-Extrusion Process

The major energy requirement for this process is the electricity to drive the extruder screw motor. Some electrical energy is used to drive rolls and winder motors. Significant amounts of water may be used for the chill rolls and cooling baths. This water is often recirculated. Water vapour and other gaseous emissions are released into the atmosphere from barrel vents, the feeder throat and the die area.

Figure 5-3 Resource Consumption and Emission Points in the Flat-Film or Sheet-Extrusion Process

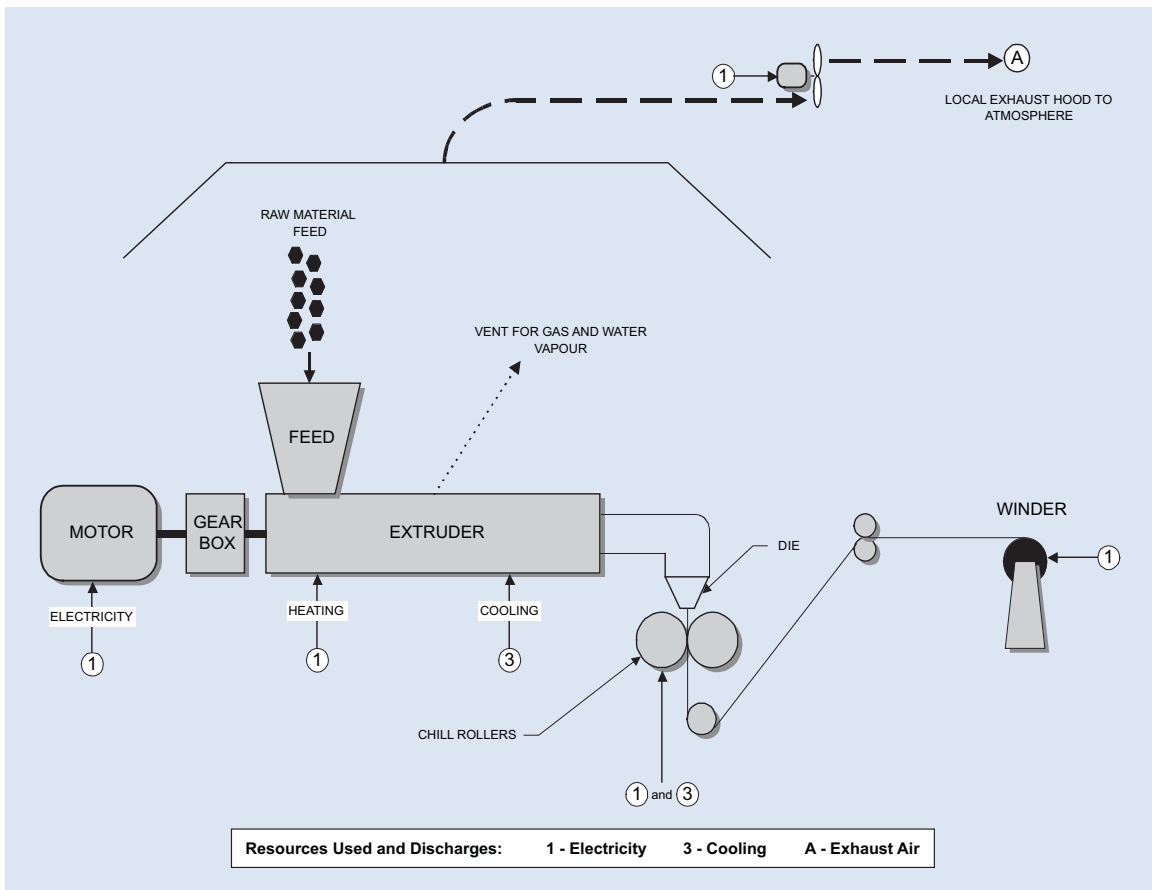

5.4 BLOWN-FILM EXTRUSION

In this process, plasticized material is forced through a ring-shaped die. Die diameters may range from a few centimetres to over two metres. The technology required to distribute the melt evenly around the die and to attempt to produce uniform-gauge thicknesses is complex.

The tube formed by the die is expanded into several times its original diameter by air pressure introduced through the die. Air blown from a ring outside the bubble, which may be several storeys high, is used to cool the material from the outside. Both the external and internal air streams may be chilled. Automatic air rings may be used to allow individually controlled air streams to be directed at specific areas of the bubble. Automatic measurements of film thickness are used to feed back information to control the velocity and/or the temperature of the individual air streams.

Once the material has solidified, the bubble is passed through a collapsing frame into pinch rolls. These rolls permit a constant pressure to be maintained inside the bubble by preventing the loss of air that is introduced through the die. The air pressure is used to control the size of the bubble and, consequently, the thickness of the blown film.

Products such as garbage bags are made from a single polymer. More complex products that require specific barrier properties, such as medical applications or food wraps, may be produced from as many as seven different materials co-extruded in a single process.

The blown film may be slit and wound on rolls as flat film. Alternatively, the film may undergo several additional processes in-line. It may be treated to improve adhesion for glues and inks, printed, gusseted, and cut into products such as grocery bags.

Throughputs in excess of 1,500 kilograms per hour have been achieved.

Polyethylene is the most commonly used polymer for high-volume blown-film extrusion applications.

Resource Consumption and Emissions in the Blown-Film Extrusion Process

The major energy requirement for this process is the electricity to drive the extruder screw motor. Significant energy is used to drive cooling fan motors and lesser amounts are required for winder equipment.

Water vapour and other gaseous emissions are released into the atmosphere from barrel vents, the feeder throat and the die area.

Figure 5-4 Resource Consumption and Emission Points in the Blown-Film Extrusion Process

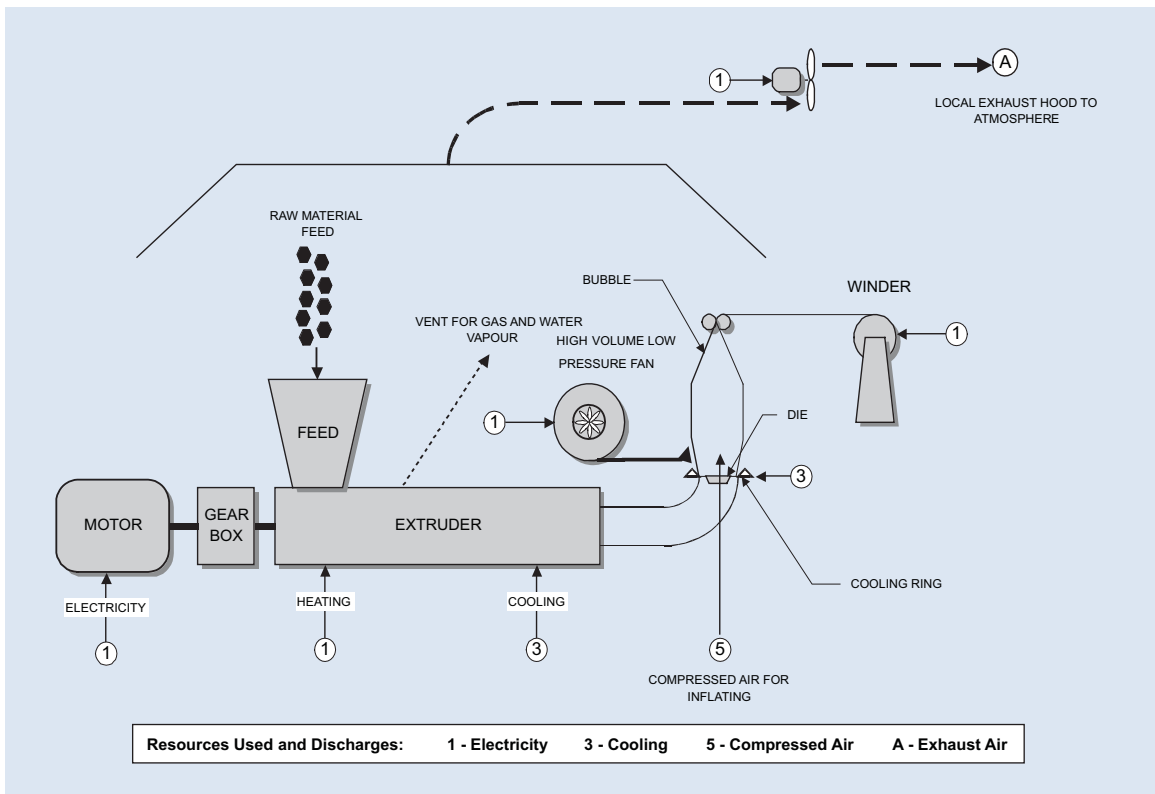

5.5 BLOW MOULDING

5.5.1 EXTRUSION BLOW MOULDING

In this process, a screw plasticizes material that is forced through a ring-shaped die to form a tube of material called a parison. For small parts, the extrusion of the parison may be continuous, in which case the maximum size of the part is limited by the tendency of the parison to stretch under its own weight. For larger parts, or more-difficult-to-process engineering materials, the melt is collected in an accumulator system and is injected intermittently by a plunger. Reciprocating screws, operating in the same manner as for injection moulding, may also be used to form a parison. To conform with product and process demands to have more or less material in specific areas of the part, moving mould components can be used to vary the thickness of the parison while it is being formed.

The parison of molten material is captured between mould halves. Air is injected into the parison to inflate the material into contact with the mould walls. After cooling, the part is ejected and trimmed of flash. Typically, multiple moulds are shuttled or rotated to allow cooling to take place while another mould is capturing the subsequent parison. Since the

pressure exerted by the air, which is used to expand the parison, is relatively low, moulds can be made of aluminum. However, polished steel moulds are typically used for parts that require a good surface finish. Moulds may be either cooled or heated, depending on the materials used and the appearance requirements of the finished product.

5.5.2 INJECTION BLOW MOULDING

Large quantities of containers, such as bottles or jars, with a good surface finish and tight tolerances may be produced by injection blow moulding. This process typically uses a three-station indexing table. The first station is used to injection mould a preform. At the second station, the preform is introduced into another mould and is blown to form the finished product. The third station is used for parts removal.

Alternatively, a preform may be produced in a separate injection-moulding machine. For high volume applications, such as beverage containers, the injection mould may have over one hundred cavities. The preform is later re-heated and inserted into a blow-moulding machine. This process permits more complex shapes and a more economical use of raw materials.

Polyethylene, polystyrene and polyethylene terephthalate resins are commonly used materials for packaging applications and beverage containers.

Resource Consumption and Emissions in the Blow-Moulding Process

The major energy requirement for this process is the electricity to drive the extruder screw motor. Some electrical energy is used to drive mould-transport mechanisms, whether electrically or hydraulically operated, and to provide compressed air for blowing. In injection blow moulding, gas may be used to re-heat preforms. Cooling water, often recirculated, may be used for moulds.

Water vapour and other gaseous emissions are released into the atmosphere from barrel vents, the feeder throat and the nozzle. When gas is used for heating preforms, the combustion contributes to air emissions.

Figure 5-5 Resource Consumption and Emission Points in the Blow-Moulding Process

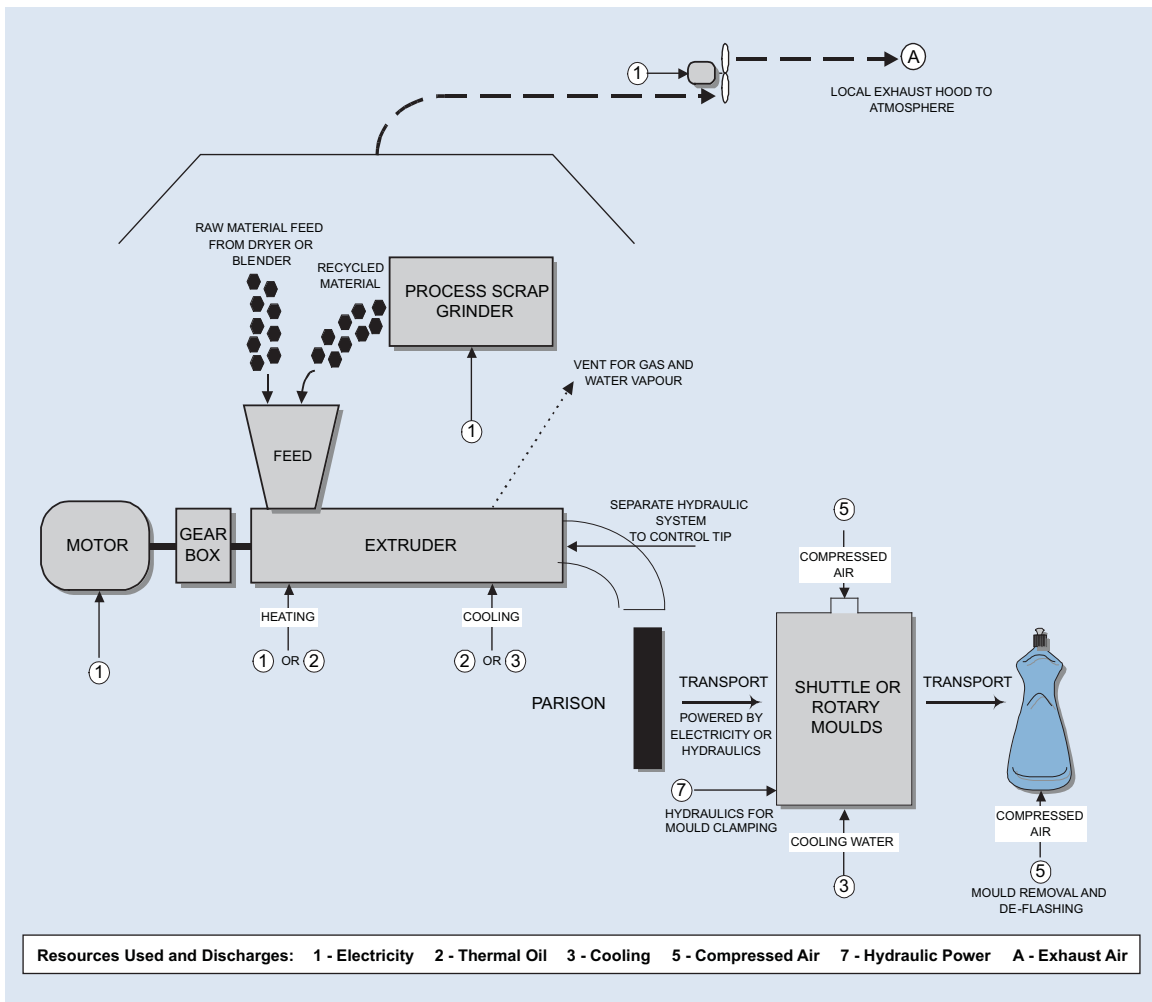

5.6 COMPRESSION MOULDING OF THERMOSET PLASTICS

Thermoset plastics behave differently when heated. These materials undergo an irreversible chemical process when heated and cannot be re-plasticized. The five processes described earlier (sections 5.1–5.5) commonly use thermoplastic materials. These soften when heated and re-harden when cooled. For most thermoplastics, this melting and cooling process can be repeated a number of times without a significant loss of physical properties.

Thermoset raw materials are supplied in either granular form or as sheet moulding compounds, which are supplied in rolls of a putty-like sheet. Typically, sheet moulding compounds contain a proportion of glass fibres that impart improved physical properties to the end product.

In compression moulding, a pre-weighed amount of thermoset material is placed into a mould cavity. Some thermoset materials can be moulded at ambient temperatures. However, shorter cycle times are achieved by using heated moulds. The heated mould is closed under hydraulic pressure (often as high as 5,000 psi) and the material flows to fill the mould.

The clamping capacity of a large compression-moulding machine may exceed 10,000 tons.

The low cost, low weight and high strength of glass-filled compression-moulded products has led to an increased penetration of this technology into many mass transportation and automotive applications.

Thermosetting polyesters, typically with added glass fibre, are commonly used in compression-moulding applications.

Resource Consumption and Emissions in the Compression-Moulding Process

The major energy requirement for this process is the electricity to drive the hydraulic system for the press. Energy is also required to heat the moulds, either directly through resistance heating, by thermal oil or by steam. Emissions from the moulding compound are released into the air during the process. Oil leaks from the hydraulic systems may contaminate stormwater.

Figure 5-6 Resource Consumption and Emission Points in the Compression-Moulding Process

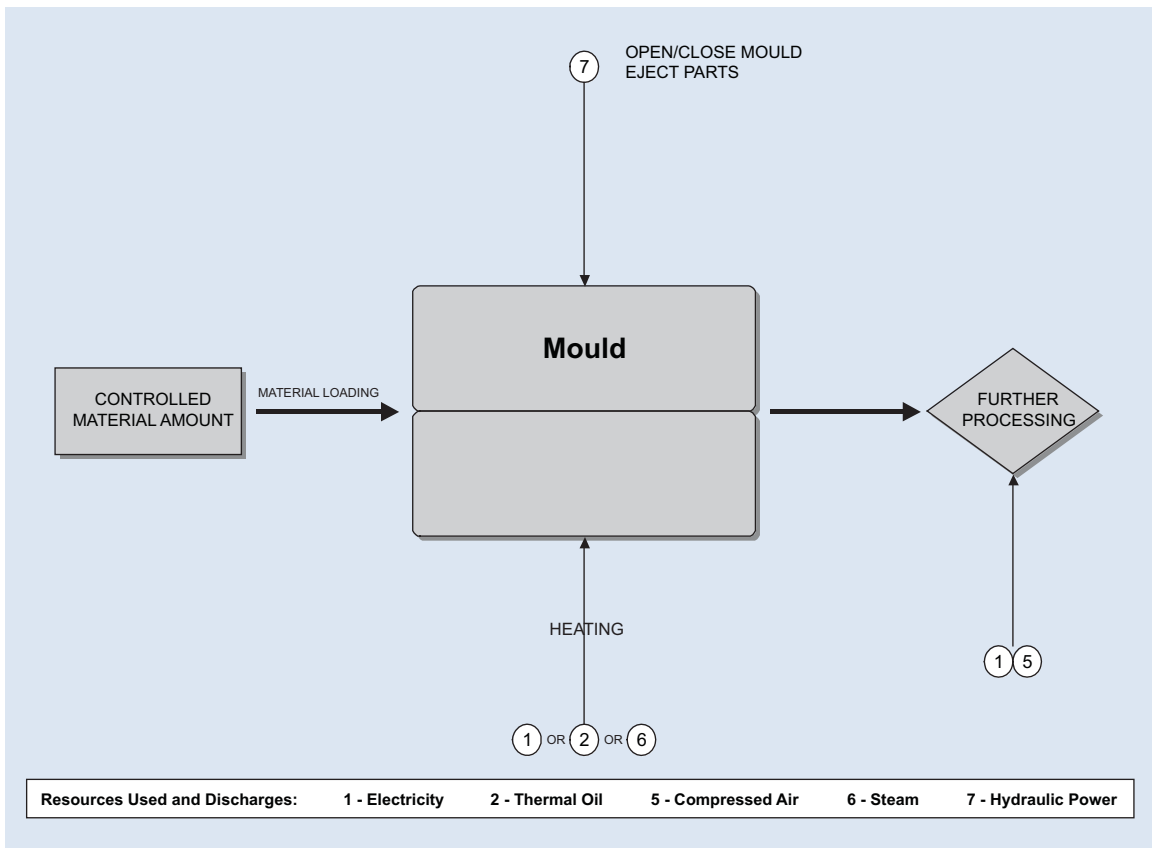

5.7 FOAM MOULDING

The foam-moulding process introduces a mixture of liquid raw materials into a mould. This mixture undergoes a chemical reaction and expands to fill the mould. For fast-reacting foams, closed moulds are used in a process called reaction injection moulding. Slower acting foams may be poured into open moulds, which are then closed while the foam expands to fill the mould.

To ensure consistency in the finished product, a precise control of the raw material mixing is necessary. Low-pressure mixing technology, used for filling open moulds, is capable of accurately metering and mixing 10 different ingredients with shot sizes ranging from a few grams to hundreds of kilograms.

For high-volume production, a single mixing head is used to fill a series of moulds that travel on a conveyor system while the foam cures. The moulds are opened at an unloading station and the finished parts are removed. For certain applications, inserts may be loaded into the mould.

A trimming operation is often required to remove unwanted flash from the parts.

The blowing agents and other chemical components may also be controlled to produce foams of various densities. Rigid foams are frequently used for insulation, while flexible foams are commonly found in furniture, car seats and energy-absorbing padding.

Polyurethanes are the most frequently used family of materials.

Resource Consumption and Emissions in the Foam-Moulding Process

The major energy requirement for this process is the electricity to drive the material-dispensing systems. Lesser amounts are required for mould transport and for hydraulic-mould operating systems, when used.

Most foam-moulding processes do not use cooling water. However, the use of solvents to clean dispensing equipment may generate liquid wastes that need special handling. Air emissions include releases from the curing material, solvents and mould releases. Solid waste from the trimmings and other scrap are often recycled in carpet underpadding.

Figure 5-7 Resource Consumption and Emission Points in the Foam-Moulding Process

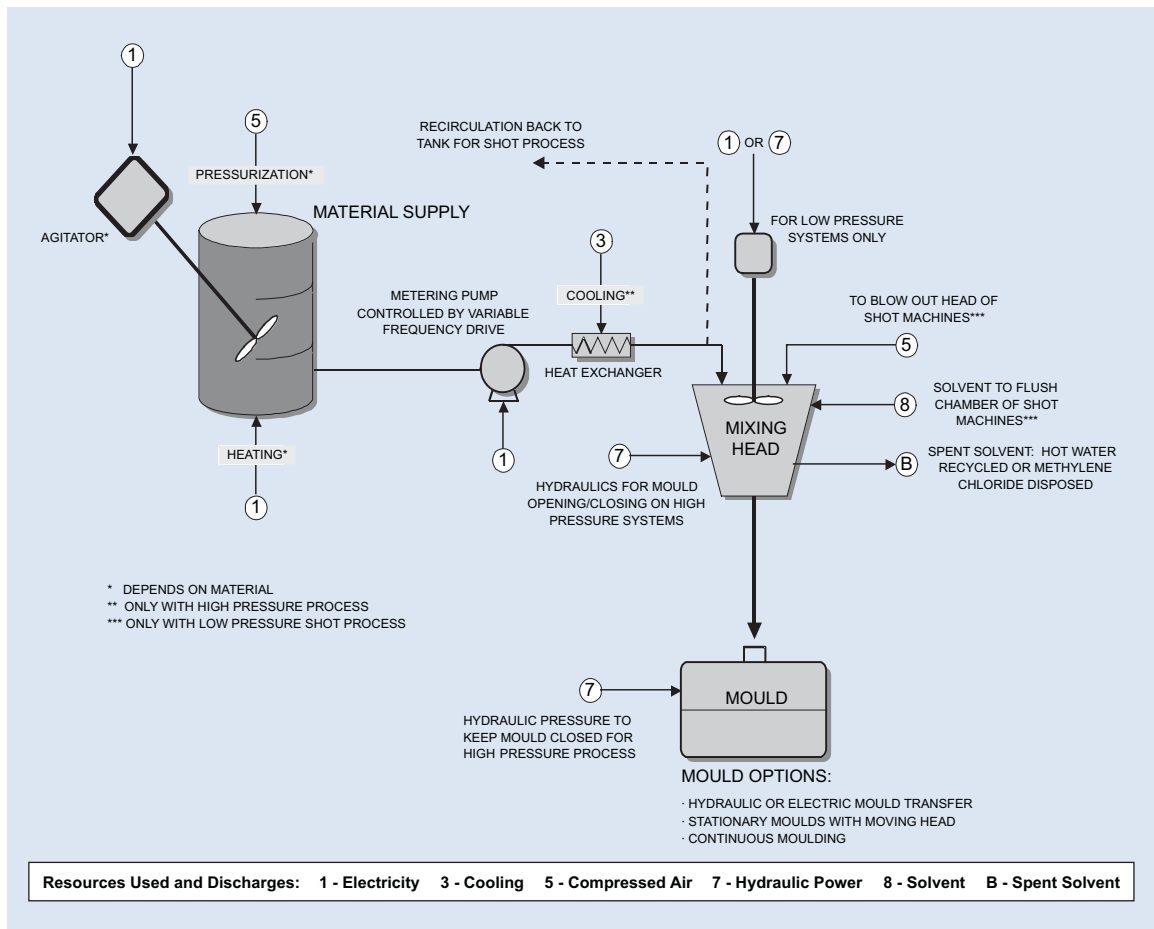

5.8 AUXILIARY SYSTEMS

In addition to the primary processes described above, most plants also use several auxiliary systems such as those listed below.

Cooling Systems – Once Through and Closed Loop

Once-through cooling uses line water to remove heat from the equipment or process prior to discharging to the sewer system. Closed-loop cooling reuses the water by removing the heat that is absorbed from the process by circulating the water either through a chiller or a cooling tower.

Closed-Loop “Free” Cooling System

A free cooling system uses ambient outside air to reduce chiller-system energy requirements in cool weather.

Hydraulic Power Unit System

Hydraulic power units are composed of a hydraulic pump usually driven by an electric motor. The pump pressurizes hydraulic fluid, which in turn powers a variety of components such as hydraulic cylinders and hydraulic motors.

Thermal Oil Heater/Cooler Systems

Thermal oil heater/cooler systems consist of a tank filled with thermal oil, a pump and either a heater or cooling element. The thermal oil is used to control the temperature of the equipment or process.

Compressed-Air System

Compressed air is used for a variety of applications within a plant that includes powering cylinders, motors and actuators. The compressed-air system consists of a motor driving a compressor that compresses air into a receiver. From there, the air typically goes through a dryer before being distributed throughout the plant to various applications.

Pneumatic Raw Material Handling System

A pneumatic raw material handling system is used for the transfer of larger quantities of materials such as pellets within a plant. In addition to the pneumatic conveying system, depending on the type of material, a mixing or blending system and a dryer may be included in the system.

The above-mentioned processes are illustrated in Figures 5-8, 5-9, 5-10 and 5-11. Resource use and discharges are pinpointed in each of the auxiliary system illustrations.

Figure 5-8 Auxiliary Processes – Once-Through and Closed-Loop Cooling Water Systems

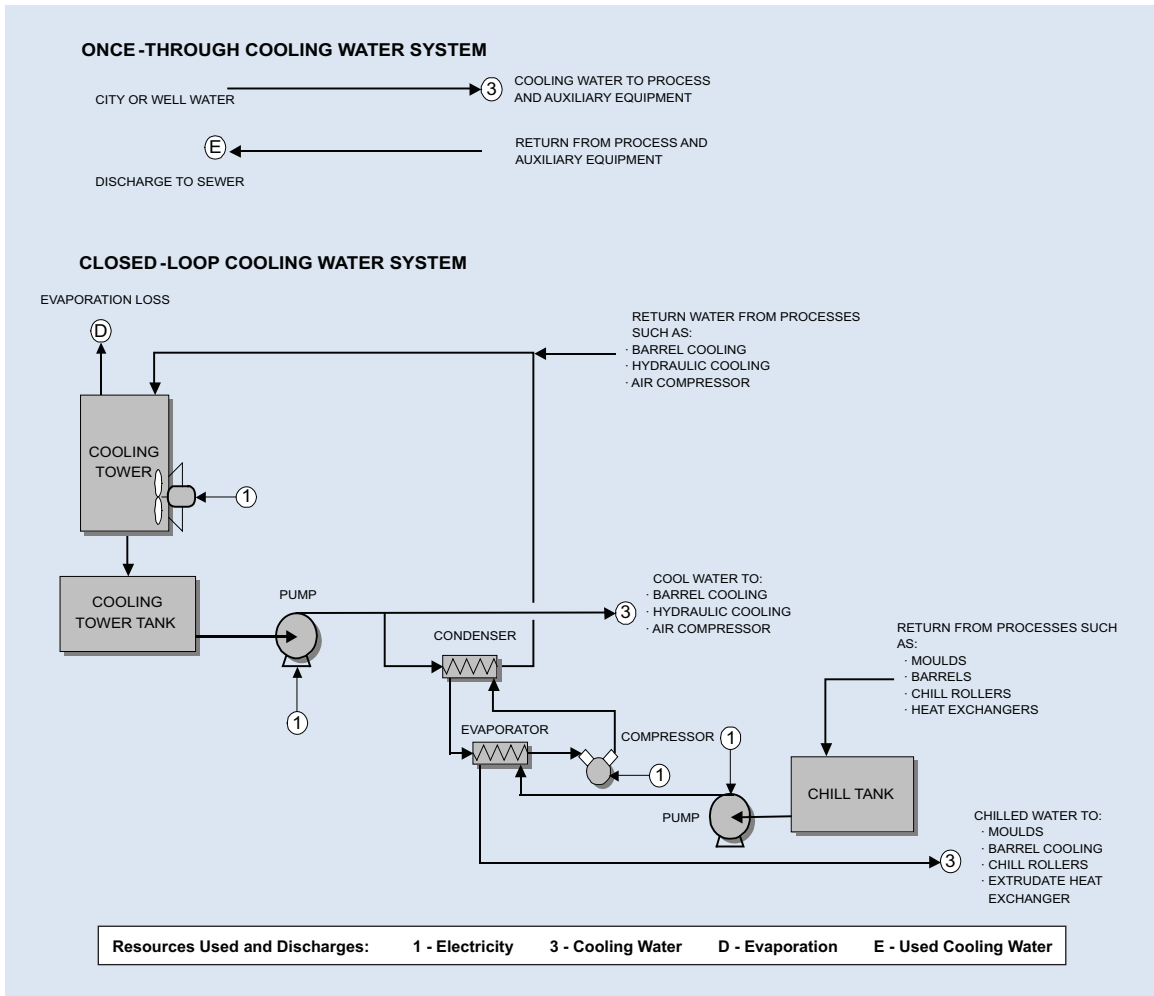

Figure 5-9 Auxiliary Processes – Closed-Loop “Free” Cooling Water System

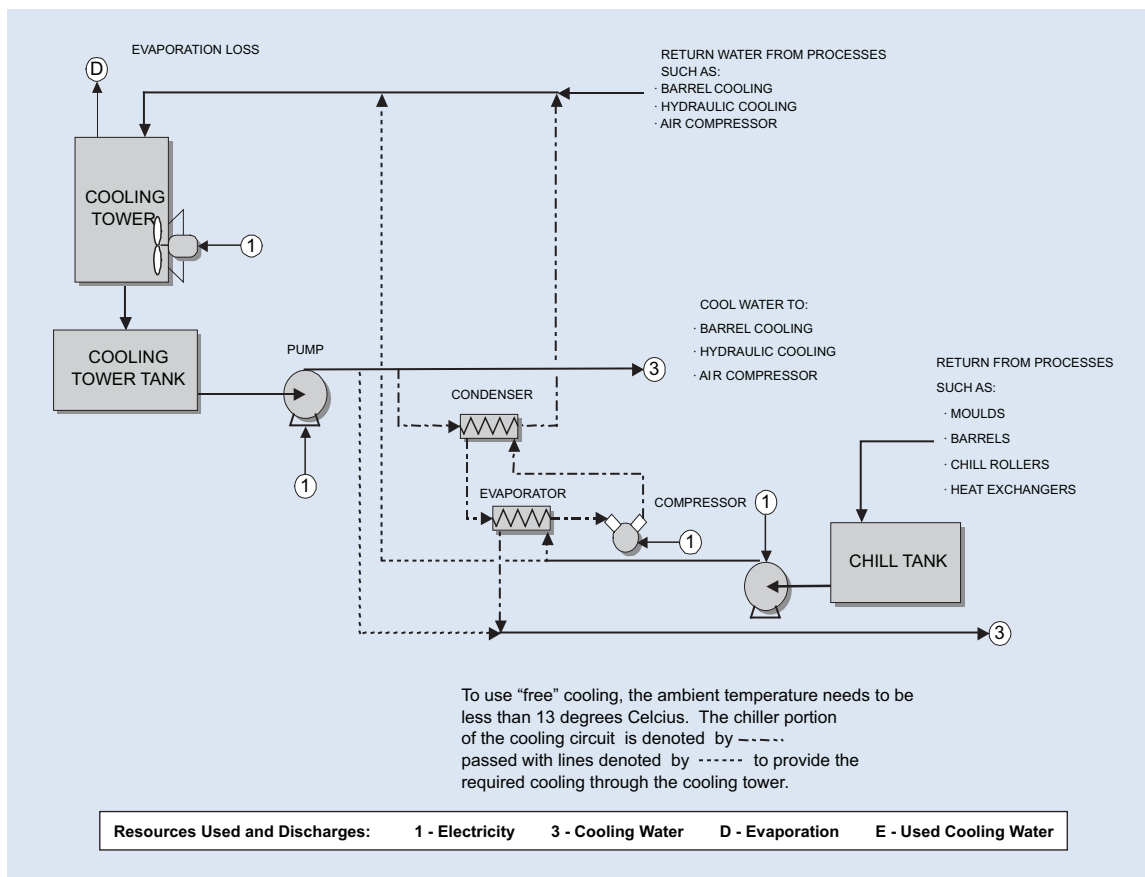

Figure 5-10 Auxiliary Processes – Hydraulic Power and Thermal Oil Systems

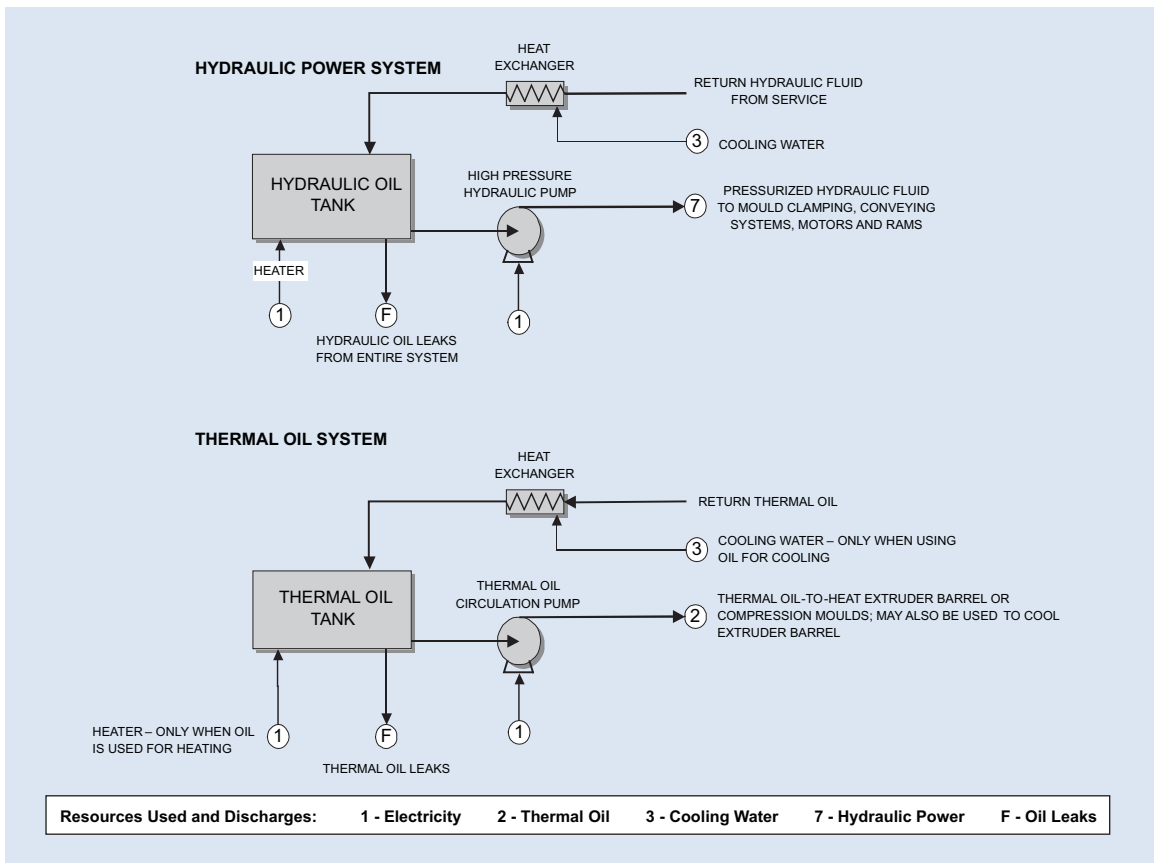
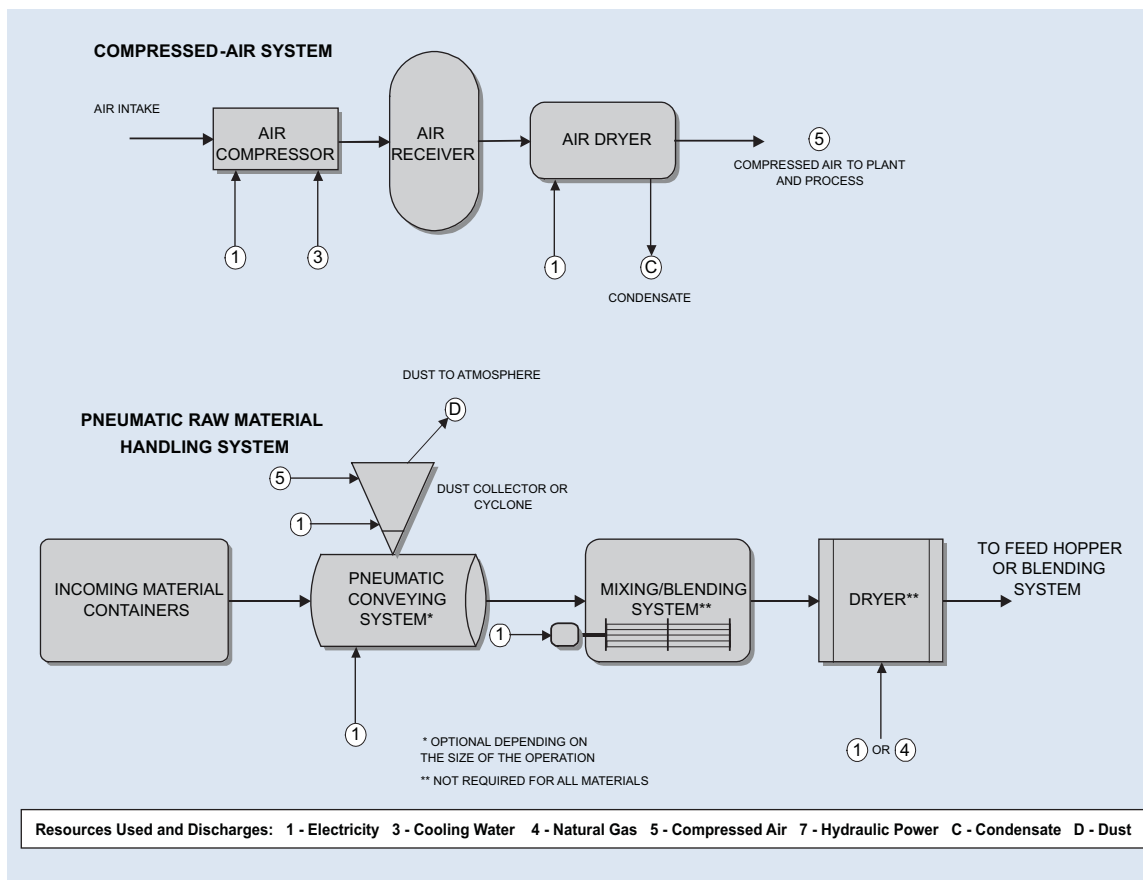

Figure 5-11 Auxiliary Processes – Compressed-Air and Pneumatic Material Handling Systems



6

GENERIC IMPROVEMENT OPPORTUNITIES



6. GENERIC IMPROVEMENT OPPORTUNITIES

Each plastics processing facility is uniquely designed and may use a variety of technologies to serve the needs of a specific market. As a result, there will be significant differences in processing conditions, energy and water use, and emissions levels. The opportunities in this chapter will need to be evaluated on an individual basis taking into account current operations.

Typical manufacturing expense breakdowns for injection moulders and film processors are illustrated in Figure 6-1 and Figure 6-2, respectively. Most of the other processes discussed in this guide will have similar cost structures. This chapter deals with major cost-saving and resource-conservation opportunities in an order of probable cost impact. As illustrated in Figure 6-1 and Figure 6-2, direct material costs typically constitute 50 to 70 percent of the total manufacturing expenses. Material savings opportunities are discussed first, followed by energy, water and other resource conservation topics.

Process-specific case studies of energy saving opportunities for injection-moulding, extrusion and blow-moulding plants are presented in Appendix IV. These studies also illustrate process, auxiliary equipment and plant energy-savings opportunities for operations with various electrical power demands.

6.1 MATERIAL CONSERVATION

Opportunities to reduce resin consumption by improved material handling and processing are discussed in this section, in addition to enhancements in operating procedures and innovative business practices. Opportunities associated with plant maintenance, consumable supplies and packaging are also discussed. Resin conservation topics include the following:

- better material handling and storage;
- enhanced processing conditions and handling of regrind; and
- improved sales, purchasing and scheduling policies.

6.1.1 GENERAL PLANT SUPPLIES

Plastics processors use a variety of cleaning and building maintenance supplies, common to all manufacturers. A significant reduction in the use of these supplies may be achieved by improved material handling, housekeeping and maintenance practices.

6.1.2 CONSUMABLES AND MAINTENANCE SUPPLIES

Typical consumable supplies in the industry include hydraulic oils, mould-release agents and solvents. Reduction and potential substitution of these materials is discussed in Section 6.5, “Emissions Reduction.”

Figure 6-1 Total Manufacturing Expense Breakdown - Typical Injection Moulder

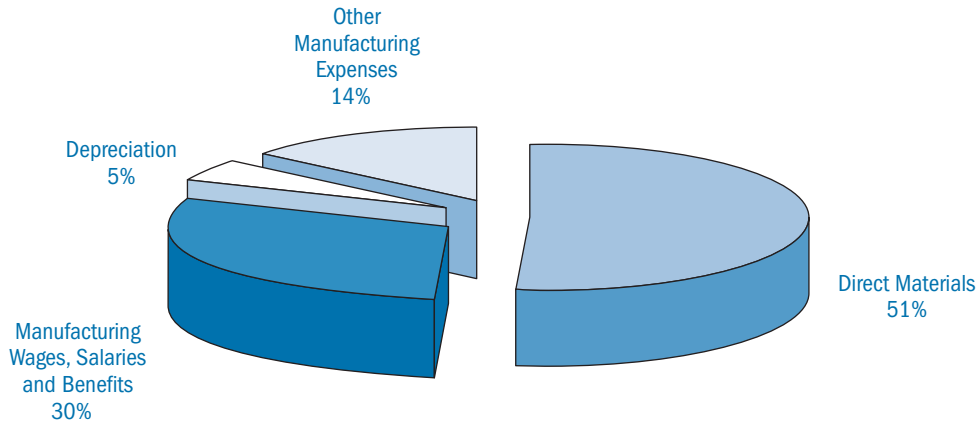

Note: Other manufacturing expenses include energy, manufacturing and maintenance taxes (except income tax), freight, etc. (Source: CPIA)

Figure 6-2 Total Manufacturing Expense Breakdown - Typical Film Manufacturer

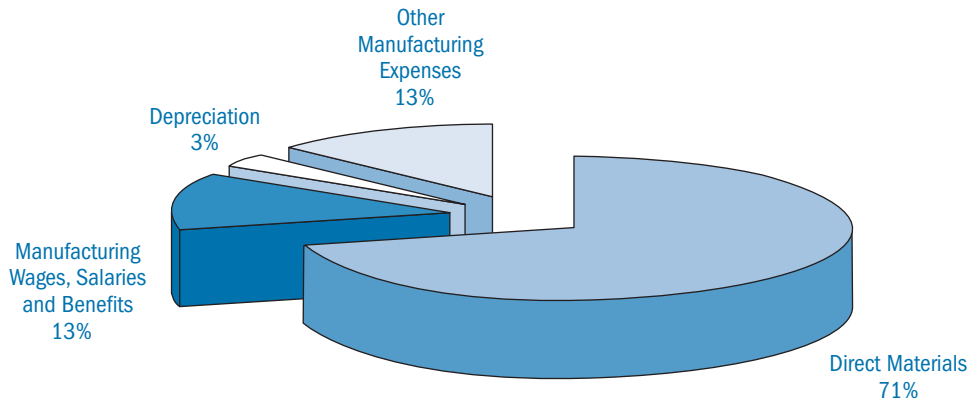

Note: Other manufacturing expenses include energy, manufacturing and maintenance taxes (except income tax), freight, etc. (Source: CPIA)

6.1.3 RESIN CONSERVATION

In most plastics processing operations, material costs constitute by far the largest single portion of manufacturing expense. A reduction in resin use has an obvious direct cost benefit and also supports the processor's emission reduction objectives.

Large-volume resin users, such as major siding and pipe producers, often compound resins in-house by adding lubricants, stabilizers and other processing aids and additives. This processing technology is not one of the major generic processes discussed in this guide. This guide assumes that the thermoplastic processors are receiving pre-compounded resins in pellet form.

Resin conservation is discussed under the following three major headings:

1) Pellet Control Program, 2) Reducing Material Use in Processing and 3) Regrind.

6.1.3.1 Pellet Control Program

Significant costs may be incurred through improper handling of raw materials. Savings may often be realized with little or no investment. A company policy that insists on an immediate cleanup of all material spills, preferably by the individual responsible for the spill, encourages improved practices and reduces the frequency of spills caused by careless handling of materials. In support of this policy, a program to keep employees informed about the price of pellets increases awareness of this important issue. A reduction of pellet spills will also improve safety, as pellet spills can constitute a significant safety hazard.

The following suggestions are offered to help prevent pellet loss and reduce costs:

a) Unloading from tank trucks or rail cars (Material losses may occur during the sampling of incoming material, purging of lines and the transfer of pellets from a tanker truck or rail car to a plant silo):

- tarps or containers should be provided to catch pellets and the unloading area should be paved to facilitate cleanup; and
- trucks and rail cars should be inspected to ensure that they are completely empty after unloading.

b) Warehousing and handling of material bags and gaylords:

- containers should be inspected for damage and replaced or repaired during unloading;
- proper handling procedures, especially by forklift drivers, should be followed to minimize handling damage;
- all partially filled containers should be clearly identified to minimize accidental mixing of materials;

- all containers should be covered to prevent contamination; and
- all containers should be fully emptied prior to disposal/recycling.

c) Material spillage and contamination during blending, drying and handling within the plant:

- over-filling of pails and other containers should be discouraged; and
- dryers and hoppers should be emptied and cleaned prior to material or colour changes.

Guidelines for a comprehensive pellet-handling program are available from The Society of the Plastics Industry, Inc. by calling 202-974-5200 or visiting www.socplas.org.

6.1.3.2 Reducing Material Use in Processing

The overall consumption of raw materials is influenced by many factors in manufacturing. Savings may be realized from both management policy changes and technical improvements.

Sales policies

Many small custom processors serve markets that demand a vast variety of material specifications and colour options. It is typically very difficult to match material purchases precisely to the production quantities. At the end of a contract, the processor may have small quantities of materials left, with no current use. These assorted materials often accumulate for many years and are eventually sold at a loss or sent to landfill. If possible, flexible shipping quantities should be negotiated with suppliers to ensure that non-standard materials are fully used.

Scheduling

In most processes, start-ups and material or colour changes create material waste due to purging losses, mixing of resin types or colours during the changeover and a quantity of off-specification product that is produced before the process becomes stable. The following scheduling practices will help to minimize these losses:

- longer runs;
- continuous operation;
- “quick die-change” practices; and
- scheduling similar materials and colours together.

Process conditions

Material can be degraded due to overheating in the process. All materials should be processed in accordance with manufacturers' recommendations. Poor instrumentation, contaminated raw material and worn-out or damaged screws and barrels also contribute to material degradation.

6.1.3.3 Regrind

Whenever possible, materials that can be reground should be processed during the production run and fed directly back into the process. This eliminates multiple handling, risk of contamination and the opportunity for hygroscopic materials to absorb moisture.

6.2 ENERGY CONSERVATION

In the majority of processes discussed, a significant percentage of the total energy demand is consumed by the extruder drive system. Variable speed drives discussed in this chapter have shown energy savings of up to 20 percent in some extruder drive applications. Mould clamping system energy savings of up to 45 percent are achievable by using a combination of technologies.

The Canadian Industry Program for Energy Conservation (CIPEC) published detailed studies of *Energy Efficiency Opportunities in the Plastics Industry* for the following three key processes: 1) Extrusion, 2) Injection Moulding and 3) Blow Moulding. These studies also cover auxiliary and plant systems. A significant portion of the savings may be achieved without significant capital spending.

Excerpts from the CIPEC studies are provided in Table 6-1.

Table 6-1 Major Energy Savings Opportunities – Process Equipment

Process	Energy Saving Technique	Potential Saving %
Extruder drive system	Specify correct size and speed of motor for application. Investigate high-efficiency motors.	20
Extruder barrel heating	Insulate extruder barrel.	15
Mould-closing, transport and clamping systems	Use variable hydraulic power to match load requirements. May be achieved by using variable speed drives, variable displacement pumps, accumulators and control systems.	45
Centralized hydraulic system	Arrange for one central hydraulic power system to supply a group of machines.	50
Compressed-air system operation	Ensure system is correctly sized, well-maintained and that the compressors are “staged.”	20

6.2.1 SPECIFYING ENERGY-EFFICIENT EQUIPMENT

Historically, many new equipment purchases have been evaluated on the basis of capital cost, installation cost, throughput and projected maintenance expense. Energy costs and resource utilization issues have received less attention.

Today, most machinery and process equipment vendors are well prepared to discuss projected energy costs. While the data presented by vendors typically describes ideal operating conditions, comparisons of energy efficiency are possible in most cases and should be factored into the purchasing decision.

Other important criteria that may be easily overlooked include:

- noise levels;
- access for maintenance and spill cleanup;
- ease of housekeeping; and
- safety.

6.2.2 REPLACING INEFFICIENT EQUIPMENT DURING MAINTENANCE

Many opportunities for improvement can be missed when maintenance is carried out under emergency conditions. The normal tendency is to replace existing equipment with an identical spare. For example, a burned-out electric motor represents an opportunity to evaluate the benefits of replacing it with a high-efficiency unit. The economics may not favour replacing a working motor with a high-efficiency one, but the calculations may show a good payback if the original has failed and requires a replacement.

Significant savings may also be achieved at little or no cost by following a regular, well-documented maintenance program. Proper maintenance procedures and schedules are generally available from equipment manufacturers. A well-documented program would schedule and co-ordinate inspection and preventive maintenance of equipment and housekeeping procedures instead of running equipment until it fails.

6.2.3 MOTORS

When purchasing new equipment or replacing worn-out motors, consider specifying high-efficiency motors especially in high-load or high-running hours applications.

Motors should be sized to operate between a 75 and 100 percent load. For non-critical applications with constant load such as fans, size as close as possible to 100 percent. Do not oversize in anticipation of more capacity unless this requirement is reasonably predictable. Oversizing results in higher capital cost for the larger motor, cabling and starters, and incurring higher operating costs due to a power factor penalty.

Some of the advantages of a high-efficiency motor include:

- operating savings;
- extended winding and bearing life;
- improved power factor;
- reduction or elimination of power factor penalties;
- reduction or elimination of capacitors used for power factor correction;
- increased ability to cope with short-term overloads; and
- less heat generation resulting in longer life and lower cooling requirements for the motor.

Payback Calculation

$$\text{kW Saved} = \text{hp} \times 0.746 \times (1/\text{Standard Efficiency} - 1/\text{High Efficiency})$$

hp = Mechanical Power Requirement

$$\text{\$ Saving} = \text{kW Saved} \times \text{Annual Operating Hours} \times \text{Average Energy Cost}$$

$$\text{Payback} = \frac{\text{Price Premium for High-Efficiency Motor}}{\text{\$ Saving}}$$

High-efficiency motors typically use from 1 to 4 percent less electricity than standard motors, and for a given application, high-efficiency motors will last longer and be more reliable.

The CIPEC *Energy-Efficient Motor Systems Assessment Guide* (2004) provides excellent information on selecting motor systems and provides the following “Rules of Thumb” when considering purchase of high-efficiency motors (HEMs):

- 1) Specify HEMs for new installations operating more than 3,500 hours per year.
- 2) Select HEMs for motors that are loaded greater than 75 percent of full load.
- 3) Buy new HEMs instead of rewinding old, standard efficiency motors.
- 4) Specify HEMs when purchasing equipment packages.
- 5) Use HEMs as part of a preventative maintenance package.

6.2.4 VARIABLE SPEED DRIVES

For applications with varying loads such as fans, blowers and pumps, variable speed drives (VSDs) should be considered for installation. The advantages of using VSDs include the following:

- energy savings of 10 to 40 percent over constant-speed motors, depending on the application;
- reduced wear on the motor by running it at reduced speed and torque for reduced capacity conditions; and
- gentle starting, which reduces power surges and wear on mechanical components.

In addition, VSDs can improve the process in applications that require control of the speed of rotation of components. An example is screw drives to maintain proper feed rates.

VSDs can also replace traditional damper controls for controlling gas-flow rate, allowing centrifugal fans and blowers to operate over a wider range without the danger of surging. Pumps too can be operated over a wide range by controlling the pump speed instead of throttling the flow with control valves. Other advantages of VSDs are reduced cooling costs, plant noise, and wear on the motors and the equipment they are driving.

There are various types of VSDs: silicon-controlled rectifiers (SCRs) with DC motors, variable-speed (VS) AC drives and Brushless DC (BDC) drives. SCR systems are not as efficient as the other two types; in addition, the SCR-DC system is maintenance-intensive. The most efficient is the BDC, but its cost is higher than that of the AC drive.

The advantages of BDCs include a greater speed range, much more precise speed regulation, full torque capacity, higher-efficiency rating, smaller size for the same horsepower and lower maintenance. The power factor is also higher than that of AC induction systems.

The most significant disadvantage to VSD motors is their increased cost, which must be evaluated against the life-cycle energy savings and the value of the other advantages. Software to calculate energy savings is available for free either directly from vendors or by downloading it off the Internet from their Web sites. The drive application must be evaluated to understand the savings potential as not all applications are good energy savings opportunities.

- *Variable torque loads* – effective speed ranges are from 50 to 100 percent maximum speed and can result in substantial energy savings.
- *Constant power loads* – typically, these applications offer no energy savings at reduced speeds.
- *Constant torque loads* – typically, these applications result in moderate energy savings at lower speeds.

Source: CIPEC Energy-Efficient Motor Systems Assessment Guide (2004)

A more detailed analysis of adjustable or VSD systems is provided in the above-noted reference.

6.2.5 HYDRAULIC PUMPS

The following is a list of things to take into account regarding hydraulic pumps:

- Operate them at more than 75 percent capacity; otherwise, a severe energy penalty is incurred.
- Do not use pressure compensating pumps because it wastes energy.
- Use variable volume (displacement) type of pumps or multiple, independently-driven, fixed displacement pumps. This option requires programmable logic controller control equipment and good maintenance to run properly.

6.2.6 HYDRAULIC SYSTEMS

When operating hydraulic systems, you should do the following:

- Use accumulators, especially for injection moulding.
- Whenever possible, power multiple hydraulic motors and cylinders from a single, central hydraulic system, especially a group of injection-moulding machines. In this way, the power requirement of the multiple machines tends to be smoothed out; maintenance costs are also reduced.
- By operating multiple machines from a single hydraulic system, a sophisticated control system is not required. Also older machines can take advantage of considerable energy savings without having to retrofit their components.
- In setting up a single hydraulic system, segregate machines or functions into similar pressure requirements; you may need to add load-sensing device if the pressure requirement is not continuous.
- On injection presses, there should be two cylinders – a small-diameter, long-stroke cylinder for mould transport and a large-diameter, short-stroke cylinder for clamping the moulds.

It is often difficult to justify upgrading hydraulic systems and components based on energy savings alone. Improvements in productivity, quality, as well as decreased maintenance costs, must also be considered.

As a rule, retrofitting older existing equipment may not be effective if the machines are small or modifications are not easily made. Buying new equipment with energy-efficient components, controls and mode of operation may be more cost-effective. It is important to ensure that the energy penalty from older technology is understood and that the implications are considered when future equipment purchasing decisions are made. If there are several machines available for production, it would be beneficial to consider using the most energy-efficient equipment if production schedules permit.

6.2.7 MACHINE COMPONENTS

It is important to replace worn out components, such as valves, with more efficient products.

On injection-moulding machines with vane-type hydraulic motors, efficiency decreases if the motor is run at less than 80 percent of rated speed. To improve speed range, install a two- or three-speed gearbox. Alternatively, replace the vane hydraulic motor with a direct-coupled-piston type of hydraulic motor, which is efficient over the entire speed range. A more expensive option is to install an electric variable-speed drive. The cost of power electronics have declined; and under some circumstances, this option may be economically viable.

6.2.8 SCREWS AND BARRELS

A high percentage of the total energy requirement (up to 30 percent) for moulding and extrusion equipment is used to plasticize material. Screw design is the most important feature on extrusion/injection machines. Screw design technology is constantly evolving and many vendors can provide information on the appropriate screw diameter, geometry and length-to-diameter ratio appropriate to a specific material and plasticizing rate. Energy savings of 20 percent are claimed in some instances. If the machine use rate is high and the production demands are predictable, a screw replacement may be warranted. Screws and barrels should be checked every five to six months. Replace or repair worn screws as the payback is quick (i.e. a few weeks).

Heater bands account for approximately 14 percent of the energy used. It is recommended that the barrel be properly insulated, which will result in both energy savings and a more easily controllable melt temperature. Insulation should not be used over mica heater bands as the insulation will reduce their operating life.

6.2.9 ENERGY MANAGEMENT PRACTICES

For plastics processors to achieve and sustain energy-cost reductions, they need to consider a systematic or continuous improvement approach to managing energy. The energy-conservation opportunities (which are largely technical in nature) described throughout this guide are important considerations in the effort to reduce resource consumption, but attention to the energy management practices that support those improvements will become more important over time (see Figure 6-3).

Figure 6-3 Energy Savings Potential Versus Time

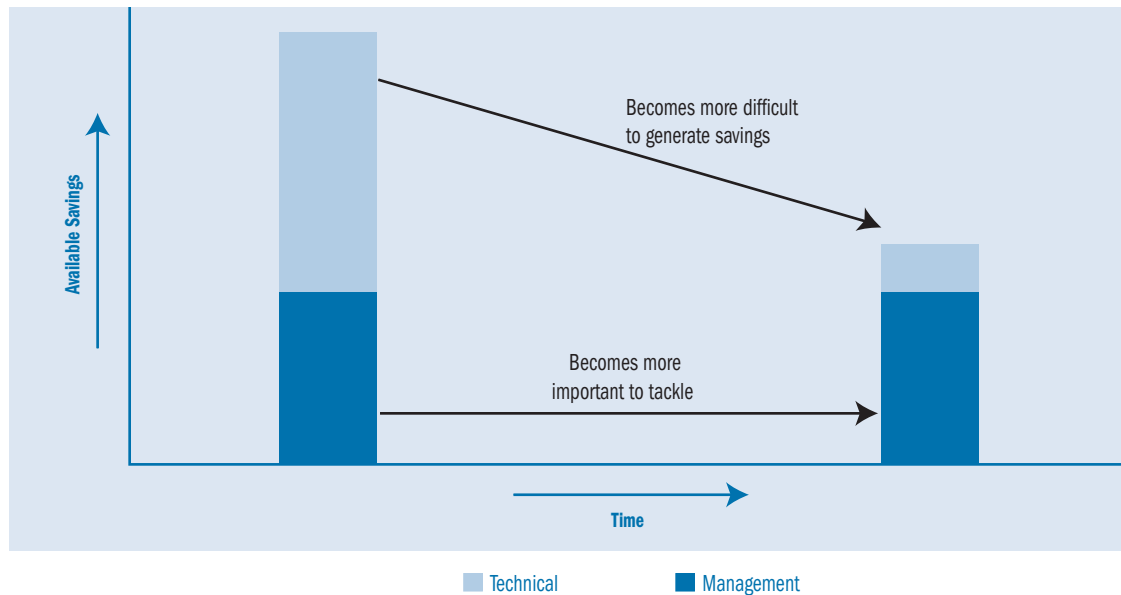

The 10 key areas of an energy management program are described below:

- **Leadership** – A feature of successful management programs is commitment and leadership from top management. This means that senior management, right through to CEO and Board-level, set the direction for energy management, demonstrate that “energy management matters” in the organization, communicate this effectively, and ensure that results are achieved.
- **Understanding** – A formal approach to quantifying the main areas of energy use and identification of opportunities for savings. Conducting an energy baseline study of operations from a comprehensive perspective may give the organization insight into opportunities for cost control beyond the already-captured “low-hanging fruit.”
- **Planning** – Planning is an essential element of any effective change process. The planning process should outline specific short-term (90 day) and longer-term (2 to 3 years) actions with defined objectives. A well-documented energy management plan will help maintain focus and realise early (and visible) benefits from energy management.
- **People** – Having a well-trained staff of people that are aware of energy management issues and are accountable for achieving energy reduction targets is a critical component of an energy management program.
- **Financial Management** – Capital and operating budgets should be reviewed in relation to energy management. Return on capital invested in energy efficiency efforts should include consideration of the life-cycle operating costs of the buildings or equipment. Procedures and incentives should be put in place to ensure that energy efficiency investments are evaluated consistently and accurately.

- **Supply Management** – On a regular basis, plastics processors should assess how energy is purchased in a competitive market, as well as reviewing mechanisms employed, to ensure a high level of quality and reliability.
- **Operations and Maintenance** – Making operations personnel aware of the required energy efficiency parameters by incorporating the parameters into operating procedures and work instructions, as well as including effective energy efficiency measures as part of standard maintenance program, are key components in sustaining energy cost savings.
- **Plant and Equipment** – A feature of a well-developed energy management process is established guidelines for new designs and innovations to enable energy efficiency to be optimised throughout a plastics processing facility.
- **Monitoring and Reporting** – Plastics processors should ensure that the right energy flows are metered and usable reports developed to track and proactively manage energy.
- **Achievement** – It is important to review implemented projects to ensure that the original objectives are achieved, to feed back results, and to make any necessary adjustments for varying processes or activities. Not only will such reviews ensure greater savings, the results can be used to develop and implement future improvement projects or processes.

Several sources are available to help plastics processors develop their energy management practices and establish a continuous-improvement program. Relevant links are provided below.

6.2.9.1 Sources for Energy Management Program Development

A copy of CIPEC's *Energy Efficiency Planning and Management Guide* is available at oee.nrcan.gc.ca/industrial.cfm.

Information on the ENERGY STAR® Program of the U.S. Environmental Protection Agency is available at www.energystar.gov/index.cfm?c=guidelines.download_guidelines.

6.3 WATER CONSERVATION

For processors who use significant amounts of process-cooling water, the following system design considerations and calculation formats may be used to evaluate the savings available from a variety of recirculating systems, versus using line water on a once-through basis.

6.3.1 SYSTEM DESIGN CONSIDERATIONS

Government statistics indicate that the plastics processing industry recirculates approximately 87 percent of its water requirements. This chapter will assist processors who are using cooling water on a once-through basis to evaluate the savings opportunities available for their process. The potential for cost savings depends on several factors such as:

- the amount of water used as once-through, non-contact cooling water (m³/h or gallons per minute);
- the associated cost of cooling water – water costs involve both the cost of the supply water, and the sewer discharges associated with disposing of the water. (The water costs in Canada vary between \$0.38/m³ to \$1.01/m³);
- the heat load of the operating equipment based on hours per year;
- the cooling water temperature required;
- capital cost of the cooling water recycle system;
- operating cost of the cooling water system; and
- cost of make-up water.

The water must truly be “non-contact” water for it to be recycled. Quite often a “blowdown” stream and chemical additives are required to control water pH, hardness, bacterial growth and suspended solids. This blowdown stream would be pumped to a sewer and, therefore, a small amount of make-up water is required. The amount of blowdown and make-up in this system should be minimal and will vary with every system.

The following are three basic cooling systems that can be implemented:

1. Portable chiller for small heat loads	(1–9 tonnes heat load)
2. Permanent chiller or cooling tower for medium heat loads	(9–36 tonnes heat load)
3. Permanent chiller and cooling tower for large heat loads	(36+ tonnes heat load)

Medium-heat load applications may be able to use a chiller or a cooling tower, depending on the process and the volume of water and cooling water temperature required. A situation with high cooling water temperature, but low cooling-water volume requirements, may suit a cooling tower system. This is due to the high operating costs of a chiller, which would offset the savings in water use costs.

6.3.2 CALCULATIONS

Cooling Water Use and Heat Load

The following section allows you to calculate the cooling water heat load.

Type of cooling: _____

Cooling water flow rate: _____ m³/h

Temperature of cooling water required: _____ °C

Temperature of cooling water after the cooling application: _____ °C

Difference in temperature (ΔT) = Temperature of cooling water
required after the cooling application – Temperature
of cooling water

= _____ °C – _____ °C

= _____ °C

Heat load (tonnes) = [Flow rate (m³/h) x ΔT (°C)] / 3

= [_____ (m³/h) x _____ (°C)] / 3

= _____ tonnes

Water Costs

This section allows you to calculate the annual water costs spent on cooling water.

Municipal water costs = \$ _____ /m³ (including sewer surcharge)

Amount water used per year = _____ m³/h x _____ hours/day x _____ days/week
x _____ weeks/year

= _____ m³/year

Annual cost of water = \$ _____ /m³ x _____ m³/year

Chiller Costs and Payback Period

Look at the heat load (tonnes) calculated above to determine the type of chiller most appropriate to the application from the information in Table 6-2.

Table 6-2 Appropriate Cooling Systems for Determined Heat-Load Ranges

Heat Load (tonnes)	Chiller Type
1–9	Portable Chiller
9–36	Permanent Chiller or Cooling Tower
36+	Chiller and Cooling Tower

Examples of heat loads, energy requirements and chiller types can be seen in Table 6-3.

Table 6-3 Examples of Heat Loads, Energy Requirements and Chiller Type

Heat Load (tonnes)	Chiller Type	Energy Requirement
6.75	Portable Chiller	14.0 kW
27	Permanent Chiller	45.9 kW
27	Cooling Tower	6.5 kW
90	Chiller and Cooling Tower	62.5 kW

Net Savings

This section will allow you to calculate the net savings for implementing a cooling system. As discussed above, the cost of make-up water should also be considered.

Use the following formula to calculate the approximate energy costs per year.

Base energy cost = \$/kWh _____ (approximately \$0.08/kWh)

Electrical energy requirement = _____ kW (from table 6.3)

Energy cost = Base energy cost x Electrical energy requirement x Hours of operation/year

= \$/kWh ____ x ____ kW x ____ hours/day x ____ days/week x ____ weeks/year

= \$ _____/year

Net Savings = Annual cost of water – [(Chiller operating cost) + (Make-up water cost)]

Payback Period

This section will allow you to calculate the simple payback period on the cooling system.

Payback period = Approximate cooling system cost / Net savings

= \$ _____ / (\$ _____ / year)

= _____ year(s)

6.4 AUXILIARY SYSTEMS AND FACILITY EQUIPMENT

This section addresses significant opportunities related to auxiliary system efficiency.

Table 6-4 contains excerpts from the CIPEC studies. It illustrates savings opportunities for various auxiliary systems.

Table 6-4 Energy Savings Potential in Auxiliary Systems

Auxiliary System	Energy Saving Technique	Potential Saving %
Material dryers (electrical)	Use high-efficiency electrical dryers.	30
Material dryers (natural gas)	Use gas-fired dryers for high-volume applications (typical for polyethylene terephthalate).	70
Dew point monitoring	Install dew point monitors on dryers.	20
Air compressor operation	Ensure system is correctly sized and well managed. If capacity is sufficient, stage compressors.	20

6.4.1 DRYERS

To provide good drying conditions, a dryer should provide the following: adequate drying temperature and dew point for the quantity of air used; adequate residence time for all the resin passing through the hopper; and good air-flow distribution through the hopper.

Gas-Fired Dryers

Several manufacturers offer modular, natural-gas-fired dryers and claim energy cost savings from 60–80 percent over electric systems. Gas-fired heaters may also be retrofitted to existing electric dryers at about 50 percent of the original price. Mechanically, the units are virtually identical to electric dryers. However, heat exchangers may be employed to maintain proper moisture levels to compensate for water that is generated in the combustion of gas. While capital costs may be higher than electric dryers, manufacturers claim payback periods averaging about 12 months for high-volume applications.

Two-Stage Dryers

Two-stage systems, which incorporate a drying oven and a dehumidifier, may be used to dewater hygroscopic resins while raising their temperature for subsequent melt processing. Manufacturers claim such systems are energy efficient, especially if waste heat from one dryer is reclaimed through a heat exchanger and re-used in the second. Two-stage systems can extend the life of dryer components (such as the desiccant in the second-stage dryer).

Smaller Heaters

Instead of central-heating systems, smaller, independently controlled heater elements may be installed in each drying bin, avoiding energy loss along pipelines or conduits. Other systems combine drying and conveying into a single unit.

Microprocessor Controls

Drying is another area where the application of microprocessor control can result in significant process improvements. Dryers are often operated at less than their maximum-rated capacity using more energy than required to remove moisture. With recently developed microprocessor control, temperature and dew point sensors installed at strategic locations in each dryer provide data input to a drying profile programmed for the specific resin being processed. The target profile automatically controls hot air flow, triggers replacement of desiccant cartridges and maintains the dew point and drying temperatures to optimize the actual material throughput and the drying conditions in the unit. However, at its present level of operational reliability, it is wise practice to supplement microprocessor control with periodic manual checks to ensure proper operation.

Insulation

The hopper or drying bin, as well as any connecting hot air conduits, may be enclosed in an insulating blanket to prevent heat loss.

Energy Recovery

The heat from the exhaust side of drying bins can be recovered through a heat exchanger and used for general plant heating, preheating incoming air, preheating material sent to an extruder, or heating material in other drying/dehumidifying bins.

6.4.2 ELECTRICAL SYSTEMS

The potential energy savings from correctly specified motors has been discussed above. Further opportunities may be found by examining the plant electrical demand as a whole. The plant electrical costs are usually based on:

- peak electrical demand (kW);
- energy consumption (kWh); and
- power factor penalty.

The peak demand often occurs at a predictable time of day and may be reduced by shutting off non-essential equipment during that period, re-scheduling operations or by improving the efficiency of the operation. Reduction of consumption is discussed elsewhere in this guide.

A poor power factor is typically caused by under-loaded AC induction motors, transformers and lighting ballasts. Utilities usually charge a power factor penalty to customers whose power factor is less than 90 percent. The common cost-effective solution for power factor correction is the addition of capacitors to the system.

6.4.3 COMPRESSED-AIR SYSTEMS

The following suggestions will help to increase the efficiency of compressed-air systems and to reduce the cost and consumption of compressed air:

- **Avoid air leaks** – Even a small leak generates significant costs; an annual survey and repair of leaks almost always pays for itself within months.
- **Operate at the lowest-possible pressure** – Look for ways to lower system pressure: if you have a specific piece of equipment that needs a higher pressure, consider using a booster at the point of delivery as opposed to setting the entire system pressure to feed the highest pressure requirement.
- **Optimize system size** – Do not oversize compressors: use adequately sized piping to reduce pressure drops, provide adequate storage (rule of thumb: 3 gallons per cubic foot per minute to be delivered).
- **Avoid water accumulation in the system** – Water causes corrosion on the inside of compressed-air lines and decreases efficiency of the entire system.
- **Draw cool air from outside the plant** – The cooler the air, the lower the moisture content and the higher the density, making it more easily compressible.
- **Use engineered nozzles** – Blow-off applications using engineered nozzles can use up to 85 percent less air than a copper tube or open line. Engineered nozzles can pay for themselves in a very short period of time.

- **Decide on a control strategy for multiple compressor units** – Investigate installing a control system that will sequence units based on pressure requirement and operating priorities. In some cases a variable speed drive on one of the compressors can be an easily justified investment.

Additional information on optimizing the efficiency of compressed-air systems is available at the **Compressed Air Challenge**[®] (www.compressedairchallenge.org) – a U.S.-based voluntary collaboration of industrial users, manufacturers, distributors and their associations, energy efficiency organizations and utilities.

6.4.4 LIGHTING

The following guidelines will assist in reducing electrical demand in lighting systems:

Reduce the number of fixtures to a level that is adequate to the job

Historically, many lighting systems have been over-specified. A reduction in the number of fixtures, bulbs or tubes will often reduce energy costs, while maintaining adequate lighting levels. Surplus ballasts should be removed if fewer fluorescent fixtures are required; ballasts draw energy even when the fluorescent tube is removed.

Use more efficient technology

Replace existing incandescent lamps with high-efficiency fluorescent, halide or high-intensity discharge lamps. Fluorescent lamps are typically 1.5 to 2 times as efficient as incandescent and high-pressure sodium lamps are 1.5 to 2 times as efficient as fluorescent lighting. Table 6-5 provides an outline of operating costs (at \$0.08/kilowatt hour), electrical consumption and light output data for various lighting types. The tabulated data include ballast contributions.

Table 6-5 Light Source Efficacy

Lighting Type	Annual Cost (\$/bulb/shift/year)	Bulb Wattage (watts)	Light Output (lumens/watt)
4-ft. Std. Fluorescent (T12) w/Std. Magnetic Ballast	7.4	46	58
4-ft. EE. Fluorescent (T8) w/Electronic Ballast	5.0	31	83
8-ft. Std. Fluorescent (T12) w/Std. Magnetic Ballast	14.1	88	70
8-ft. EE. Fluorescent (T8) w/Electronic Ballast	8.5	53	102
8-ft. High Output Fluorescent (T12) w/Std. Magnetic Ballast	20.6	129	65
8-ft. High Output EE. Fluorescent (T8) w/Electronic Ballast	12.8	80	100
400 W High-Pressure Sodium	74.4	465	97
400 W Metal Halide	72.8	455	63
400 W Mercury Vapour	72.0	450	40

Lights should be turned off when not required

Timers, occupancy sensors or photocells will assist in reducing energy costs by turning off or dimming lights. As a general rule, incandescent lights should always be turned off when not required, fluorescent lights when not required for more than 15 minutes, and halide or high-intensity discharge lamps if not required for more than one hour.

Some additional factors to consider are the following:

- Lighting energy is wasted when there are no local switches.
- Activities requiring high visibility or colour resolution require task lights.
- Excess lighting levels are counter-productive, waste energy and can harm eyesight.
- Day-lighting is better than artificial lighting in that it is less expensive and emits less heat.
- Lighter, reflective ceiling, floor and wall colours require less lighting.
- Multiple lighting levels (ambient and task) save energy.

- Examples of ambient lighting levels are:
 - Office – 30–50 FC (300–500 lux)
 - Laboratory – 30–50 FC (300–500 lux)
 - Production – 50–75 FC (500–750 lux)

Additional information on optimizing lighting in manufacturing facilities can be found at www.iesna.org.

6.4.5 PROCESS INSULATION

Thermal insulation on process equipment and piping has the following benefits:

- prevents heat loss;
- assists in maintaining consistent process temperatures;
- prevents condensation; and
- assists in maintaining a comfortable and safe workplace.

6.4.6 BUILDING HEATING, COOLING AND VENTILATION

Many plastic processes and auxiliary systems emit heat. It is sometimes cost-effective to capture process heat with suitable heat exchangers, or to blow heated air from areas such as a compressor room and to use this waste heat to supplement facility-heating requirements.

Thermostats may be programmed to reduce the heating load during off hours. Other cost saving methods include the following:

Reducing excess air infiltration

- Improve caulking and weatherstripping around doors and windows.
- Install air locks and air curtains.
- Install low leakage dampers.

Adequate ventilation may be obtained by following the guidelines published by the American Society of Heating, Refrigerating, and Air-Conditioning Engineers (ASHRAE).

Destratification

Energy savings may be achieved during the winter heating season by preventing stratification (the tendency for warm air to rise and collect near the ceiling) in the following ways:

- install ceiling fans;
- introduce make-up air near the ceiling level; and
- use radiant heating.

Additional information on heating, ventilating and air-conditioning (HVAC) system optimization and energy efficiency is available at www.aceee.org/ogeece/ch3_index.htm.

6.5 EMISSIONS REDUCTION

The reduction of emissions from plastics processing operations is best achieved through carefully designed programs to optimize all aspects of the manufacturing process, particularly with respect to the use of raw materials including energy and water. Continuous improvement is best achieved through the implementation of an effective environmental management system. In addition to further discussion on this system, other energy improvement opportunities are also discussed that will focus specifically on material conservation, energy conservation, water conservation, auxiliary systems and facility equipment, and case studies relevant to the plastics processing sector.

6.5.1 AIR RESIDUALS – GASES AND DUST

Greenhouse gas emissions, principally CO₂, can be reduced by ongoing improvements in energy efficiency. Improvement opportunities are outlined in Section 6.2, “Energy Conservation.” These have the dual effect of both improving energy efficiency and reducing CO₂ emissions per unit of product processed.

6.5.1.1 Volatile Organic Compounds Reduction

The following strategy has been endorsed by three of the four groups mentioned in Section 2.5.1.1 (the PVC working group has yet to develop a strategy relevant to its sector). For new or modified facilities, the working group proposed to adopt the Canadian Council of Ministers of the Environment (CCME) *Environmental Guideline for the Reduction of Volatile Organic Compound Emissions from the Plastics Processing Industry*, published in July 1997. This guideline provides standards and guidance for the reduction of VOCs in new or modified facilities.

For existing facilities, the plastics processing working group supports the application of BACTEA (Best Available Control Technology Economically Achievable), as recommended in the 1990 CCME NO_x/VOC Management Plan. The working group proposes to work toward the adoption and implementation of the CCME guideline for VOC reductions in existing plastics processing facilities where possible, and under BACTEA conditions. This would involve the adoption of the CCME guideline provisions relating to, for example, equipment and operating standards, and training and record keeping.

The following are additional highlights of the VOC emissions-reduction initiatives specifically proposed for each sub-sector group relating to existing facilities:

Composites: The industry is committed to achieving the tenets outlined in the CCME document. CPIA is planning educational packages to provide the hundreds of Canada-based fabricators the means of reducing emissions containing VOCs. The instructional guidelines are intended to provide a basis for implementing consistent and uniform control measures and industrial operating standards. The guidelines focus on the reduction of VOC emissions from processing and cleanup operations, the handling and storage of VOC-containing materials, and the handling and disposal of waste.

Resin suppliers, on average, have already achieved the reduction in styrene monomer content from 48 to 45 percent for general-purpose resins. Secondly, the industry in Canada has seen a dramatic shift from open-moulding to closed-moulding operations. This trend will continue across North America in the coming decade. It is estimated that there will be a further 10 percent reduction in open-moulding operations resulting in a further 10 percent reduction in VOC emissions prior to any further reduction in styrene monomer content.

EPS Foam: The industry will continue to move toward processing low-pentane content resin as it becomes available in the marketplace. The aim is to achieve the CCME target of 5 percent VOC content by weight of resin consumed on an aggregate basis where economically feasible. The sector will use recycled material content, where possible, to displace raw materials that have a higher pentane content. As well, existing facilities will focus long-term capital plan objectives on replacing existing process equipment with equipment capable of processing low-pentane resin.

PE Foam: The industry will proceed on two parallel fronts. First, the industry will secure the acceptance and funding to pursue research into an alternative-blowing agent. Second, the industry will further investigate possible methods to reduce the percentage of butane used in production.

Vinyl: The group has not yet launched into the development of a reduction strategy. The group has indicated, however, that the application of inks in printing causes more VOCs than processing using calendering. A major company processing calendered vinyl is part of a separate working group established to address VOC emissions from printing operations.

General Recommendations

Care must be taken to ensure that resin manufacturers' recommended processing temperatures are not exceeded. Vendors' material safety data sheets should be consulted for appropriate processing procedures, precautions and engineering controls. For many materials, local exhaust hoods are recommended near areas where materials are heated.

It is good management practice to conduct periodic air sampling surveys within the plant. Air sampling surveys serve the dual function of identifying air emission issues that may need to be addressed and also indoor plant air quality issues in relation to the *Canada Occupational and Health and Safety Regulations*.

6.5.1.2 Dust Reduction

Fugitive dust levels may also be reduced through the use of collection systems located close to key locations within facilities, such as material handling areas and locations dedicated to blending and grinding operations.

6.5.2 WASTEWATER AND LIQUID WASTES

The recirculating of cooling water has been discussed in a previous section.

The discharge of wastewater to a sanitary sewer system is regulated under municipal by-laws. To minimize the risk of contaminating wastewater discharges, engineering controls and a spill prevention plan should be put in place. Typical preventive measures include the following:

- oil interceptors for plant discharges;
- blocking building drains in areas where spills are likely; and
- secondary containment for storage tanks.

Good housekeeping practices will reduce the introduction of particulates into the sanitary sewer system. Properly engineered oil separators should be installed if oil spills are likely. Whenever possible, floor drains within the plant should be capped or sealed to contain minor spills.

Secondary containment should be provided for storage tanks containing petroleum products or hazardous chemicals.

Liquid wastes that require special handling and are commonly generated by the plastics processing industry include used hydraulic oils, spent solvents and other chemicals that should be properly stored and disposed of in accordance with provincial regulations.

Municipalities regularly sample plant discharges. However, they often fail to inform the manufacturers of exceedances; it is incorrect to assume that the operation is in compliance if no complaints are received.

6.5.3 SOLID WASTE

Source separation programs should be instituted for cardboard, steel, fine paper, glass and corrugated cardboard. Many companies already recycle packaging materials. Used gaylords are in demand by many industries for use as storage containers.

A number of Canadian firms specialize in recycled plastic materials. Clean pellets or regrind may be sold to these companies for re-pelletizing or re-sale.

6.5.4 NOISE

A noise survey should be conducted to identify areas that may exceed Occupational Health and Safety Regulation limits. Engineering controls should be used to reduce noise levels, whenever possible. Personal protective equipment must be supplied if controls are not feasible and should be provided in areas where employee comfort can be increased.

6.5.5 STORMWATER

Stormwater, if it is discharged into a ditch or another “surface watercourse,” may fall under federal or provincial/territorial jurisdiction. The limits on contaminants are typically more strict than for sanitary sewers. A stormwater management plan should be in place to reduce the risk of contamination.

6.6 ENVIRONMENTAL MANAGEMENT SYSTEMS

Well-designed environmental management systems (EMSs), such as ISO 14001 and resource conservation programs, will assist processors to achieve the objectives of minimizing the impact of plant operations on the environment and reducing costs.

An EMS is that aspect of an organization’s overall management that addresses the immediate and long-term impact of its products, services and processes on the environment.

An EMS is essential to the organization’s ability to anticipate and meet growing environmental performance expectations and to ensure on-going compliance with municipal, provincial/territorial, national and international requirements. Evidence of an effective EMS has become an important part of obtaining corporate financing and helps to maintain real estate property values.

The ISO 14001 EMS standard provides an internationally recognized structure for developing and maintaining environmental systems. In many ways, it complements the well-known ISO 9000 series of quality standards.

ISO 14000 series standards involve the elements listed below (many of these standards are still under development):

- Environmental Management Systems
- Environmental Performance Evaluations
- Environmental Auditing
- Life-Cycle Analysis
- Environmental Labelling
- Environmental Aspects in Product Standards

A detailed listing of the ISO 14000 series standards can be found in Appendix II.

Setting up and Managing an Environmental Management System

The effectiveness of an EMS may be improved by applying the following common management principles, which can contribute to the success of any project:

- top management commitment;
- clear definitions of responsibility and accountability;
- well-defined, realistic goals; and
- effective program planning and implementation.

Most successful programs start with an audit. The audit determines how the environment is impacted by plant activities, how resources are being used, and identifies possible opportunities for improvement and for savings. Some plants have the internal resources to conduct an audit. Assistance and publications are available from utilities and government sources. If the environmental impacts are significant, if resource consumption is high or if a preliminary assessment shows significant savings potential, the opportunity may be pursued by using internal resources or with the assistance of a consultant specializing in the field.

A reduction in the use of resources supports the objectives of an EMS. Lower resource use typically has a favourable impact on reducing environmental effects.

Vinyl Council of Canada Environmental Management Program

Members of the Vinyl Council of Canada (VCC) recognized the need to demonstrate their commitment to not only complying with environmental health and safety laws, but to being more accountable and responsive to society's evolving concerns. The VCC also felt that it was important that their actions be documented and measurable. In 2000, the VCC began implementation of its Environmental Management Plan (EMP), which had been developed over the previous two years. The EMP consists of six guiding principles, five commitment areas and 32 action steps, which are outlined in the following table.

Principles	Commitment Areas	# of Action Steps
Development of Mutual Trust	Management Commitment, Implementation and Review	11
Environmental Management System	Operations	7
Integration of Priorities	Resource Conservation and Waste Management	4
Compliance Plus	Product Stewardship	5
Sharing Expertise	Communications	5
Continuous Improvement		

6.7 CASE STUDIES IN RESOURCE CONSERVATION

There are a wide variety of case studies available that demonstrate successful resource conservation efforts. The following summaries of case studies show some of the successes achieved by plastics processors who have applied specific resource conservation measures.

Energy Conservation

- An Ontario vinyl siding manufacturer recently saved about 10 percent of its energy costs by undertaking a series of process changes and other initiatives. Many of the changes were direct suggestions from employees.
- A mid-sized processor of flexible vinyl undertook an \$8,000 energy audit (of which 50 percent was government-funded) and identified \$80,000 in annual savings.
- ***Improving Energy Efficiency at U.S. Plastics Manufacturing Plants*** – this document was prepared by The Society of the Plastics Industry, Inc. and the U.S. Department of Energy. It is an excellent Summary Report and reproduction of 11 case studies. The case studies highlight energy savings opportunities identified and implemented at U.S. plastics manufacturing facilities. The site assessments were carried out in 2003, and the report summarizes the implemented total savings as of March 2005. For the 11 sites, the overall annual average cost savings identified was \$149,253 per site. Implemented total annual cost savings averaged \$68,454 per site as of March 2005. The implemented total annual cost savings represents about 10 percent of the annual energy costs for the 11 sites. The key areas identified for improvement in the assessments included improvements to water cooling systems, reducing changeover times at presses, HVAC improvements, motor management systems and insulation. A selection of sample case studies from the above-noted report is provided in Appendix IV.

A copy of the full Summary Report and individual case studies can be downloaded at www1.eere.energy.gov/industry/bestpractices/plastics_manufacturers_save.html.

- **Corporate Energy Management at C&A Floorcoverings** – Collins & Aikman (C&A) has implemented a management system for matching energy efficiency initiatives with business goals. After two years, C&A achieved 10 percent savings on an annual natural gas expenditure of \$824,500. The full case study can be reviewed at www.ase.org/uploaded_files/industrial/CollinsAikman%20v04.pdf.
- **Industry Energy Services Program Summary** – information from energy audits of 67 Ontario plastics processing facilities conducted by the Ministry of Environment and Energy (now Ministry of the Environment) from 1985 to 1997, are found in Appendix I. The study demonstrated rapid paybacks from improved technology and from heat recovery.

Water Conservation

- A blown film manufacturer in Atlantic Canada saved over 85 percent of its water throughput by introducing a closed-loop cooling system. This same company reduced its waste by 20 percent while growing the business by 15 to 20 percent.
- **New United Motor Manufacturing, Inc.** – a water conservation program resulted in savings of more than 270,000 gallons per day. By installing re-circulating pumps in the evaporative air conditioning system and recycling process water, the company conserves enough water, daily, to supply 2,000 houses. The case study can be viewed at www.stopwaste.org/docs/nummi.pdf.

Environmental Management Systems

- **Van Dorn Plastics Machinery Company, Strongsville** – This U.S. manufacturer reduced waste generation by more than 35 percent despite increasing production volumes. Its highly participative Pollution Prevention Pays program was developed as a part of its Total Quality Management initiative. This case study is available at es.epa.gov/techinfo/case/comm/vandorn.html.

Waste Management Systems

- An injection-moulding operation in Toronto undertook a waste audit and has saved \$30,000 from source separation. The company now moves “clean” materials to recyclers, therefore eliminating the disposal fees.
- A company in New Zealand arranged to take delivery of plastic waste and even obsolete products created by its customers. While this started as an environmental initiative, it has resulted savings of NZ\$250,000 per year and has solidified relationships with customers. This company now designs its products with disposal in mind.

7

NEW AND EMERGING TECHNOLOGIES



7. NEW AND EMERGING TECHNOLOGIES

Many facets of plastics processing and related manufacturing technologies evolve continuously. New and modified materials and end-use applications are introduced on an ongoing basis. However, unless a new processing technology represents a quick payback on capital investment, it would be expected to penetrate the industry slowly. Despite significant investments in new equipment by many manufacturers in the last few years, a significant portion of machinery in the plastics processing sector is several decades old. This chapter discusses technologies that are developed, but which have not yet enjoyed full acceptance by the industry.

7.1 RAW MATERIAL DEVELOPMENTS

The existing variety of plastic raw materials available to the processor is large and yet still growing. Materials for high-volume applications undergo an ongoing development process in an attempt to improve product performance and ease of processing and to reduce cost. Vendors attempt to increase their market shares by replacing competing plastic resins currently in use and by supplanting other materials.

In the last few years, a new family of metallocene-catalyzed plastics has been introduced. The excellent physical properties of these materials are expected to lead to increasing use in applications such as co-extruded packaging for food wrap or as a modifier of other materials as agents that improve clarity.

7.2 ROBOTICS

Robotics are used to improve machine speed, reduce costs, increase safety and improve quality by maintaining consistent machine cycles.

The most common and simple robotics application is a sprue picker, which is used to ensure positive removal of the sprue from an injection mould. More advanced uses include parts removal and packaging from multiple cavity moulds, especially in applications where products could be damaged by handling or where maintaining correct orientation of the parts is important.

Another important use of robotics is to place metal inserts into moulds. The accurate positioning of inserts is critical. In some instances, the loading of inserts manually could also pose a safety hazard to the operator.

Some blow-moulded applications (e.g. pesticide containers) require moulded-in labels to ensure that the labels remain in place. Robots are used to place labels into blow moulds during the operating cycle.

7.3 ALL-ELECTRIC INJECTION-MOULDING MACHINE

The majority of injection-moulding machine manufacturers currently produce a line of entirely electrically operated machines, without hydraulics. Some of the major advertised advantages over conventional machines are as follows:

- **More efficient use of energy** – Energy savings of more than 50 percent are claimed over conventional hydraulic presses. Motors are sized for the application, fully speed adjustable and only operate when required.
- **Quiet, clean, compact operation** – Manufacturers claim noise levels in the 73 decibel (dB) area, versus 78 dB for conventional machines. (A 10-dB reduction is generally perceived as a 50 percent reduction in noise levels.) This makes the machines quiet enough to operate in an office environment. Electric machines also eliminate oil mist problems. The machine footprint is also smaller than conventional machines of an equivalent size.
- **Better control of process** – More precise and repeatable control results in faster set-ups and better adherence to tolerances. Manufacturers are suggesting that the repeatability and reliability of electric-moulding machines will make unattended “lights out” operation a realistic possibility.
- **Hydraulic oil related issues eliminated** – No need to replace or dispose of hydraulic oil. Also, machine-cooling requirements are eliminated.
- **Faster response time (cycle time)** – The reaction time of electrical controls is quicker than electrical/hydraulic units.

Initially, all-electric machines came at a premium of approximately 30 to 50 percent over conventional hydraulic machines. The premium is now estimated to be in the 20 to 30 percent range as the initial development costs have partially passed. Available data on market volume of all-electric machines in the U.S., Asia and Europe are presented in Figure 7-1.

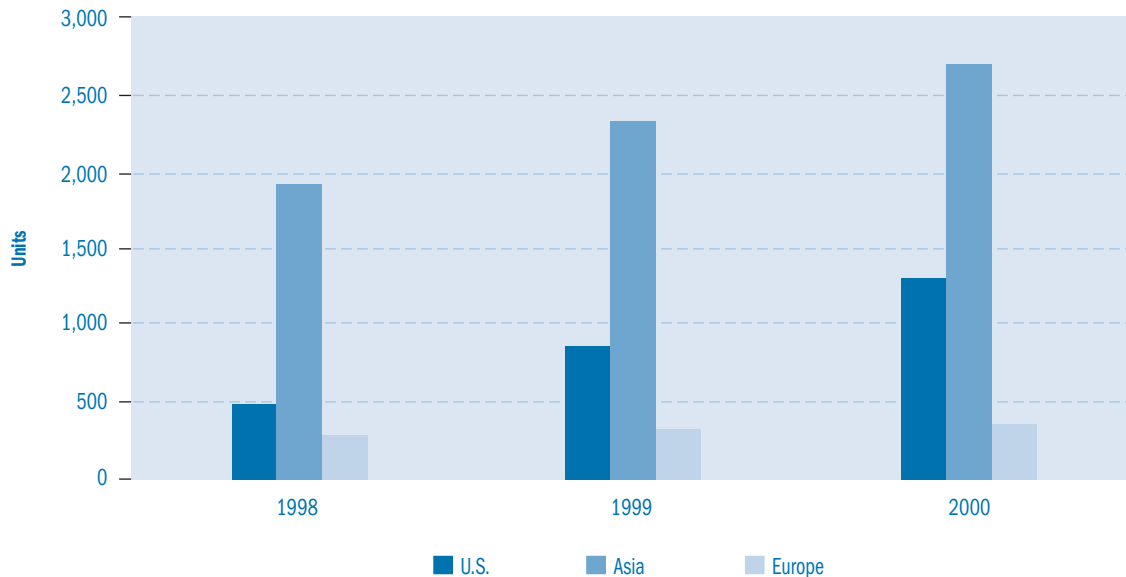
Figure 7-1 Market Volume for All-Electric Machines in Units

Source: Canadian Plastics, December 2000

While the all-electric machine market is growing, it is still less than 10 percent of the new injection-moulding machine market (46,000 machines in 2000). Even with the reduced capital cost premium, the differential energy savings are not sufficient to produce a short enough payback for most Canadian companies. Discussions with several plastics processors in Canada indicate that the all-electric machines are being considered, but very few have been purchased.

There are also hybrid machines available that consist of a hydraulic clamp with electric screw drive and injection.

7.4 MICROWAVE DRYING

Microwave drying units that dry material using conventional microwave technology and a variety of specific applications are still under development. The main advantage of microwave drying is reduced drying time, allowing more rapid material turnover and lower energy costs. However, the technology is capital intensive and prototype units are batch-oriented while most processes use continuous feed systems. Further development will be required to make microwave technology widely accepted for this application.

7.5 GRANULATORS

Manufacturers are developing special rotors or two-stage cutters that result in a lower horsepower requirement and lower use of energy for a given throughput.

7.6 RAPID PROTOTYPING

Historically, prototyping of components often necessitated the manufacture of steel moulds. This is both time consuming and costly. Furthermore, design changes often meant that the initial prototype mould had to be extensively modified or scrapped.

In recent years, the following technologies have been developed to produce prototypes directly from computer designs, without the need for moulds:

- **Stereolithography** – A prototyping process that uses a laser to deposit consecutive thin layers of a polymer in solution. The layers are gradually built up to form a model, which may be quite complex in configuration.
- **Selective laser sintering** – Used to build up layers of material in a manner similar to stereolithography with dry powdered materials, rather than liquid polymers.
- **Ballistic particle manufacturing** – A recently developed prototyping method that has adapted a technology similar to ink jet printing. Microscopic particles of molten thermoplastic are “shot” with great accuracy to precise points to build up a three-dimensional model.

7.7 GAS-ASSISTED INJECTION MOULDING

Designers of parts for injection moulding have historically been constrained by the need to maintain relatively constant and thin sections in the finished products. This is because thick wall sections, in addition to requiring a long cooling time, had a tendency to develop sink marks – depressions in the part surface caused by the contraction of the plastic while cooling. Gas-assisted moulding helps to overcome these problems and permits a broader range of applications.

In this process, nitrogen gas is injected into the interior of the melt at the thick sections. The gas pressure creates a hollow area within the plastic and forces the solidifying plastic against the mould. This eliminates sink marks and reduces raw material cost. For certain parts, material savings of up to 50 percent have been reported.

7.8 CO-INJECTION MOULDING

Co-injection moulding provides another method for improving physical properties and/or reducing raw material costs. This process allows for two dissimilar materials to be injected simultaneously through concentric nozzles. The designer of the part has the latitude to design parts with an outer skin made of a material with the desired visual or physical properties and to inject an internal core with a material that is less expensive, stronger or lighter.

7.9 TOOLMAKING TECHNOLOGY

Computer Assisted Design and Computer Assisted Manufacturing technologies continue to have an increasing importance in shortening lead times and reducing tooling costs. Digitized information is routinely transmitted from customer to tool vendors and is used directly to guide toolmaking machinery, such as Numerically Controlled milling machines.

Electrical Discharge Machines (EDM) have largely replaced pantographs for making precise tool cavities. Extrusion dies are manufactured using wire-cut EDM equipment to produce complex configurations at a lower cost.

Potential exists for an increased use of superior mould alloys to reduce moulding cycles. The majority of tool steels currently in use were developed prior to World War II.

7.10 VOLATILE ORGANIC COMPOUND (VOC) CONTROL TECHNOLOGIES

There are various technologies available, some of which have been used by fabricators in Canada for the purpose of reducing VOC emissions and VOC-containing materials used in plastics processing operations. The main focus of efforts to date has been in the implementation of processes and work practices leading to reductions in VOCs. Some examples of control technologies currently available and/or under development are as follows:

- **Expanded polystyrene** – Low-pentane beads have recently been made available by one company while other companies are still in the research and development stages. At this time, the use of a low-pentane bead is likely more suitable for medium- and high-density products rather than low-density products such as insulation board. As well, changes in equipment and processes are necessary in order to use the low-pentane bead. Technology and capital cost implications must be considered before this control technology can be used widely.
- **PVC** – The trend in this sector continues to be the development of low-VOC plasticizers. Other options include solvent-free stabilizers and low-VOC cleaners.
- **Reinforced plastics/composites (polyester resins)** – Reduction options have focused on the use of lower VOC materials and improving process efficiency through equipment changes and good operating practices. Initiatives undertaken to date in the reinforced plastics sector include the use of charcoal filters in stacks to reduce odour, VOC emission levels and solvent use, and include the implementation of solvent recycling programs consistent with the CCME guideline. In addition, in-house acetone recovery programs have been implemented. Other reductions in VOC emissions can be accomplished by undertaking the following: using low-styrene and wax-suppressed resins and low-VOC cleaners, and by using high-efficiency spray applicators and closed-moulding technology.

7.11 SYNCHRONOUS TORQUE MOTORS

Extruder equipment manufacturers are increasingly including synchronous torque (ST) motors in their machine design. These motors are compact, very quiet, require little maintenance and are energy efficient. Typically, an ST motor will use 10 to 20 percent less energy than a direct current motor and 5 to 10 percent less energy than a three-phase alternating current motor. They deliver constant torque over a wide speed range and possess high torque at low speeds. The motors have been employed in commercial extrusion applications such as tubing, blown film, sheet and continuous extrusion blow moulding. They have also been used in downstream components such as chill rolls, winders and re-winders.

ST motors have been available for several years and are likely to be used increasingly throughout the industry.

8

BENCHMARKING AND PERFORMANCE MONITORING



8. BENCHMARKING AND PERFORMANCE MONITORING

Performance ratios are useful in assessing a facility's efforts to reduce energy and water use, and effluent discharges. Establishing a baseline measurement of resource consumption and waste output allows a company to evaluate the improvements made in operations and equipment over time. A series of generic formulae for calculating these ratios is presented here.

For individual pieces of process equipment that are suspected of having significant potential for improvement, it is possible to measure or calculate energy consumption and to develop similar ratios. These can be compared to published data on more efficient equipment and used to evaluate and prioritize energy improvement projects.

The following performance ratios calculate both the process and non-process consumption of energy and water use (including utilities devoted to lighting, heating, ventilating and air conditioning). All of these can be calculated directly from the company's utility bills. Any improvements made within a facility should result in a decrease in the ratio.

8.1 RAW MATERIALS USAGE

A key benchmark indicator is raw materials usage. Most facilities have the ability to calculate expected or "standard" raw material consumption through the costing system. If the actual consumption, obtained through purchase records, differs significantly from expected consumption, this may be an indication of controllable losses and should be investigated. Often, accurate data are available only after a physical inventory. These "raw material variances" may indicate significant inefficiencies in material handling, scrap rates, set-ups, or the process may also be used to identify unprofitable products.

As the resin processed in a specified period appears as the denominator in the following calculations, it is important to define usage accurately. Preferably, the kilograms used should be obtained from sales records to avoid counting scrap, purgings or other waste as material "processed."

8.2 UNIT ELECTRICAL ENERGY USE

The following formula is suggested for use in computing estimates of electrical energy use per unit of plastics material processed at any given facility over any specified time period.

$$\frac{\text{Total kilowatt hours electricity consumed} \times 3.6}{\text{Total kilograms resin processed}} = \text{Unit electrical energy use in megajoules per kilogram}$$

8.3 UNIT NATURAL GAS ENERGY USE

The following formula is suggested for use in computing estimates of natural gas energy use per unit of plastics material processed at any given facility over any specified time period.

$$\frac{\text{Total cubic metres natural gas used} \times 37.2}{\text{Total kilograms resin processed}} = \text{Unit natural gas energy use in megajoules per kilogram}$$

8.4 REDUCTION IN CO₂ EMISSIONS PER UNIT OF ENERGY

The following formula will provide an estimate of the amount of direct CO₂ emission reduction associated with a reduction in natural gas energy use:

$$\frac{\text{Megajoules of natural gas energy reduced} \times 49.68}{10^6} = \text{tonnes CO}_2\text{-equivalent emission reduction}$$

Source: Environment Canada (1999), Canada's Greenhouse Gas Inventory – 1997 Emissions and Removals with Trends.

8.5 UNIT WATER USE

The following formula is suggested for use in computing estimates of water use per unit of plastics material processed at any given facility over any specified time period.

$$\frac{\text{Total cubic metres of water used}}{\text{Total kilograms resin processed}} = \text{Unit water use in cubic metres per kilogram}$$

Benchmarking is a valuable tool for comparing performance between and among manufacturing facilities. However, great care must be used to ensure that the data are valid and comparable. For example, in the plastics processing sector, various processes have a wide range of energy requirements. It is often difficult to find precisely identical conditions in other locations and many companies are reluctant to share detailed information with their competitors.

The Plastic Film Manufacturers Association of Canada and the Canadian Plastics Industry Association (CPIA) publish financial and operating ratio results on an annual basis. These surveys are available for purchase by members and non-members of CPIA. Information on obtaining the survey is available on the CPIA Web site www.cpia.ca.

100

Some companies have been successful in obtaining useful information on a reciprocal basis from firms that produce similar or identical products for different geographical markets. Raw material and equipment suppliers may be helpful in facilitating these contacts.

Benchmarking is an important tool for processors interested in the continuous improvement of their processes and facility. Collecting the initial data and determining appropriate ratios is the first step in the improvement process. It defines what parameters are important and how they will be measured, which results in a starting point against which improvements can be compared. Benchmarking focuses the processor on improved performance and gives the organization specific goals to work toward.

9

OTHER HELPFUL INFORMATION



9. OTHER HELPFUL INFORMATION

A series of additional reference materials about energy and environmental improvements in plastics processing are described in the following section. In most cases, contacts are provided for acquiring follow-up information.

9.1 MISCELLANEOUS REFERENCE MATERIALS

CIPEC Energy Efficiency Planning and Management Guide (Canadian Industry Program for Energy Conservation [CIPEC]). This document describes the methodology for setting up and running an effective energy management program, and provides worksheets for evaluating the energy savings potential from improvements in lighting, electrical systems, boilers, steam and condensate systems, heating and cooling, HVAC, waste heat recovery, etc. Available on-line at www.oee.nrcan.gc.ca/industrial. For further information, fax the CIPEC Secretariat at 613-992-3161, or send your request by e-mail to info.ind@nrcan.gc.ca.

Operation Clean Sweep: A Manual on Preventing Pellet Loss (The Society of the Plastics Industry, Inc.). This manual provides detailed guidance for minimizing raw material losses in the plastics processing industry. The manual covers policies and procedures and recommends a goal of zero loss of pellets. For further information, contact 202-974-5200, or visit www.opcleansweep.org.

Natural Gas Applications for Industry, Volume VII: The Plastics Industry (American Gas Association, 1992). This study examines cost-saving opportunities by using gas for a broad range of processing technologies and ancillary equipment. Operating, technical and cost considerations are discussed and the opportunities are ranked. The document provides useful data and methods for assessing the cost-effectiveness of alternative energy inputs. Visit www.aga.org/pubs.

Plastics Recycling: Products and Processes (Society of Plastics Engineers). A comprehensive survey of the technical, business and environmental components involved in the recycling of plastics (i.e. polyethylene terephthalate, polyolefins, polystyrene, polyvinyl chloride, engineering thermoplastics, acrylics, commingled plastics, and thermosets). Visit www.4spe.org

Environmental Guideline for the Reduction of Volatile Organic Compound Emissions from the Plastics Processing Industry (Canadian Council of Ministers of the Environment [CCME]). Nitrogen oxides (NO_x) and volatile organic compounds (VOCs) react in the atmosphere in the presence of sunlight to create ground-level ozone, a major component of urban smog. This report results from a specific initiative under the CCME NO_x/VOC Management Plan, the overall aim of which is to reduce the formation of ground-level ozone by controlling NO_x and VOCs from a variety of new and existing sources.

This document will guide manufacturers and operators of plastics processing plants on how to reduce VOC emissions from production, processing, cleanup, handling and storage of VOC-containing materials, as well as on how to handle and dispose of wastes. It covers production activities for a number of plastics: expanded polystyrene, cellular polyethylene foams, polyvinyl chloride and thermoset polyester resins used in reinforced plastics and composite products.

It also contains information on material, equipment, process and operating norms for plastics processing facilities; norms for record-keeping and training; and recommended operating practices and testing protocols. This document can be ordered from CCME from its Web site at www.ccme.ca/publications.

9.2 PLASTICS PROCESSING INDUSTRY ASSOCIATIONS

Canadian Plastics Industry Association (CPIA)

The CPIA is the voice of the plastics industry in Canada. CPIA delivers its services through regional offices and can be a valuable source in the areas of technology, trades, health and safety, and the environment. CPIA is located at 5915 Airport Road, Suite 712, Mississauga, Ontario, L4V 1T1. Telephone 905-678-7748, Fax: 905-678-0774. Visit www.cpia.ca.

Environment and Plastics Industry Council (EPIC)

EPIC was formerly known as the Environment and Plastics Institute of Canada and is now a Council of the Canadian Plastics Industry Association. It provides a wide range of general information about integrated resource management and plastic solid waste issues. Other resources include technical reports and information for solid waste managers about plastics recycling collection and sortation methods. EPIC is located at 5915 Airport Rd., Suite 712, Mississauga, Ontario, L4V 1T1. Telephone: 905-678-7748, ext. 231, Fax: 905-678-0774. Visit www.plastics.ca/epic.

Society of Plastics Engineers (SPE)

The objective of the SPE is to promote the scientific and engineering knowledge related to plastics. This association holds an annual technical conference, which attracts a wide audience interested in all technical aspects of the plastics industry. For information about the SPE, call 203-775-0471 or visit www.4SPE.org.

9.3 INDUSTRY DIRECTORIES AND GUIDES

Recycling Markets and Recycled Products Directory (Environment and Plastics Institute of Canada). Provides a listing and cross-indexing of the participants in all aspects of plastics recycling in North America. The guide is available from EPIC at www.plastics.ca/epic.

Industrial Programs Division (Natural Resources Canada, Office of Energy Efficiency [OEE]).

You can view or order several of the OEE's publications on-line at www.oee.nrcan.gc.ca/industrial.

Hydro One energy efficiency publications. The Hydro One Web site has a searchable database of energy efficiency publications at www.hydroone.com.

9.4 ENVIRONMENTAL/RESOURCE AUDIT GUIDANCE DOCUMENTS

Workplace Guide – Practical Action for the Environment (Harmony Foundation of Canada, 1991). This guide was developed to introduce methods for implementing environmentally sustainable practices in industry. It describes tools to be used by organizations to assess environmental strengths and weaknesses, develop a strategic plan and implement improved environmental practices, including resource conservation. It offers a comprehensive step-by-step approach to help identify both economic and environmental benefits through positive thinking, serious commitment and co-operative action. Harmony Foundation of Canada also has climate-change-related publications. Its publications can be ordered from the Web site at www.harmonyfdn.ca/pubs.html.

The National Round Table on the Environment and Economy (NRTEE) has a number of programs that may be of interest to plastics processors. Information on programs and publications includes the following:

- Eco-Efficiency Indicators in Business.
- Environment and Sustainable Development Indicators.
- Sustainable Development Issues for the Next Decade.

NRTEE publications can be found at www.nrtee-trnee.ca.

9.5 POLLUTION PREVENTION GUIDANCE DOCUMENTS

Pollution Prevention Planning: Guidance Document and Workbook (Ontario Ministry of the Environment, 1993. PIBS 2586E. ISBN 0-7778-1441-2). The workbook introduces pollution prevention planning and implementation concepts and principles; offers a model/approach to initiating team-planning exercises; and provides worksheets and checklists for implementation. Available on-line at www.ene.gov.on.ca/envision/gp/2586e.pdf.

Canadian Standards Association has a wide range of published standards and guidelines for pollution prevention and climate change mitigation. Its publications can be reviewed at www.csa.ca.

9.6 ENVIRONMENTAL MANAGEMENT SYSTEMS

The Canadian Manufacturers and Exporters (CME), in conjunction with BRI International Inc., has developed tools to help companies identify the gaps and implement ISO 9001, 14001 and 18001 standards. These tools are accessible at the CME Web site at www.cme-mec.ca/national/template_na.asp?p=44.

9.7 WEB SITES

Many manufacturers, government agencies, research organizations, utilities and industry associations have Web sites. A relevant selection of some of these sites include the following:

- Canadian Plastics Industry Association (www.cpia.ca)
- Natural Resources Canada, Office of Energy Efficiency (oee.nrcan.gc.ca)
- Environment Canada (www.ec.gc.ca/climate/home-e.html)
- Centre for the Analysis and Dissemination of Demonstrated Energy Technologies (www.caddet.org/index.php)
- United States Environmental Protection Agency Web site has information on the substitution of hydrofluorocarbon for hydrochlorofluorocarbons for the purpose of reducing the emission of ozone-depleting substances (www.epa.gov/docs/ozone/resource/business.html)
- United States Department of Energy (www.energy.gov)

9.8 ACRONYMS

ABS acrylonitrile butadiene styrene

AC alternating current

BDC brushless direct current

CPI formerly Canadian Plastics Institute, now Canadian Plastics Industry Association

CPIA Canadian Plastics Industry Association

CPRA Canadian Polystyrene Recycling Association

DC direct current

EPA Environmental Protection Agency

EPIC formerly Environment and Plastics Institute of Canada, now Environment Plastics Industry Council

EPS expanded polystyrene

GPP general purpose polystyrene

HCFC hydrochlorofluorocarbon

HE high efficiency

HDPE high density polyethylene

HFC hydrofluorocarbon

HP horsepower

HVAC heating, ventilation and air conditioning

ICI industrial, commercial and institutional

JIT Just in Time

LDPE low density polyethylene

LLDPE linear low density polyethylene

MOE Ministry of the Environment

PC polycarbonate

PE polyethylene

PET polyethylene terephthalate

PP polypropylene

PS polystyrene

PVC polyvinyl chloride

3Rs reduce, reuse and recycle

RCO Recycling Council of Ontario

SPI Society of the Plastics Industry of Canada, now CPIA

VOC volatile organic compound

VSD variable speed drive

9.9 GLOSSARY

Band heater

Electrical resistance heater that encircles the barrel of a screw to provide supplementary heating and temperature control.

Barrel

Cylinder that houses the screw in an extrusion or moulding process.

Blender

A unit to mix and meter resins and/or additives in desired proportions.

Blow moulding

A process that uses compressed air to inflate a hollow tube of plastic inside a mould.

Blown-film extrusion

A process that uses air to inflate and cool a “bubble” of plastic into a thin film. Typically used for manufacturing plastic bags.

Captive processor

A manufacturing operation that produces plastic products for internal use, rather than for sale.

Cartridge heater

A tubular heater often inserted into a mould to provide controlled heating.

Chiller

A unit designed to circulate a coolant (often water) to processing equipment.

Coextrusion

The process of extruding two or more different resins at the same time into a single end product.

Contaminant

Foreign materials (such as dirt, metals, incompatible resins, organic waste, oil or the residues of the contents of plastic containers) that make plastic materials more difficult to process and cause quality problems in finished products.

Degradable plastics

Plastics specifically developed or formulated to break down after exposure to sunlight or microbes.

Die

A metal plate through which molten material is forced. A precisely designed and cut profile in the die forces the molten plastic to assume a desired shape and to begin the cooling process.

Energy recovery

A process that extracts energy value from a substance such as air, water or solid waste and transfers it to another medium to be used again. Examples are heat recovery from exhaust streams to preheat incoming air or burning solid waste as fuel to generate heat.

Extrudate

Material that has been forced through a die in an extrusion process.

Extrusion

The process of forcing molten plastic through a die to produce continuous lengths of material with a desired profile.

Fillers

An inert substance added to plastic to reduce cost, or to improve physical properties.

Foaming agents

Chemicals added to plastics and rubbers that generate gases during processing and produce a cellular structure.

Grinding

The process of reducing plastic components into smaller particles suitable for feeding into a process.

Injection moulding

A plastics manufacturing process that injects molten material into a closed mould under high pressure.

Injection blow moulding

A plastics manufacturing process that combines injection and blow moulding. An injection moulded preform is transferred to a blow moulding station to be processed into the final configuration.

Just in Time (JIT)

A manufacturing philosophy designed to reduce inventories and lead times by reducing set-up times in the manufacturing process.

Monomers

The basic chemical building blocks used to create plastic polymers (long chain molecules).

Mould

A two-part unit into which material is introduced and which is configured to produce a desired shape. The mould is often cooled to speed up the solidification of molten material. After solidification, the mould is opened to remove the finished part.

Multi-cavity

Refers to a mould with more than one cavity. For high volume production, moulds with more than one hundred cavities are common.

Off-spec resin

Any resin that does not meet its manufacturer's specifications, but may still be offered for sale.

Ontario Regulation 347

Waste Management—General Regulation 347, under Ontario's *Environmental Protection Act*, sets out standards for solid waste disposal sites and waste management systems, and governs the handling, transport and disposal of registerable liquid industrial and hazardous wastes.

Parison

A round hollow tube of molten plastic that is extruded from the head of a blow-moulding machine.

Payback

Payback (simple payback) is the ratio of the annualized saving from a process or machinery improvement divided by the capital and installation cost of the improvement project.

Pellet

A small piece of plastic resin, suitable for feeding into a process.

Plastics

Synthetic materials consisting of large polymer molecules derived from petrochemicals or renewable sources. Plastics are capable of being shaped or moulded under the influence of heat, pressure or chemical catalysts. Polymer resins are often combined with other ingredients, including colourants, fillers, reinforcing agents and plasticizers, to form plastic products.

Polymer

A very long chain molecule built up by repetition of small chemical units, known as monomers, strongly bonded together.

Preform

An injection moulded intermediate product that is inserted into a blow-moulding machine.

Process

Aspects of a manufacturing operation, such as moulding or extrusion, that are directly related to the physical transformation of the material.

Properties

The physical characteristics of materials that may be used to differentiate plastics among themselves and other materials.

Reinforced plastics

Plastic materials that have added reinforcing materials, such as glass fibres or mats.

Resin

A synonym for “polymer.”

Screw

A shaft with flights, confined within a barrel, that conveys material from a hopper to a die or a mould. The material is plasticized during this process through a combination of mechanical “shear” heating and external heat provided by band heaters around the barrel.

Shot

A precise amount of molten plastic material introduced into a mould during the injection moulding process.

Sheet moulding compound

A ready-to-mould fibreglass reinforced polyester material used for compression moulding.

Strip heater

A flat electric resistance heater.

Thermoplastics

Plastic resins that can be repeatedly softened by heating, shaped by flow into articles by moulding or extrusion, and hardened.

Thermosets

Plastic resins that are hardened or “cured” by an irreversible chemical reaction that creates strong cross-links between the polymer molecules. Once formed, thermosets cannot be re-melted without degrading the resin.

Three Rs (3Rs)

The reduction, reuse and recycling of waste.

Virgin materials

Any raw material intended for industrial processing that has not been previously used.

APPENDICES



APPENDIX I: ISO 14000 STANDARD SERIES

Number	Standard Title
14001	EMS – Specification With Guidance for Use
14004	EMS – General Guidelines on Principles, Systems and Supporting Techniques
14010	EA – General Principles of Environmental Auditing
14011.1	EA – Audit Procedure Part I: Auditing of EMS
14012	EA – Qualification Criteria for Environmental Auditors
14014	EA – Initial Reviews
14015	EA – Environmental Site Assessments
14020	EL – General Principles
14021	EL – Self-Declaration, Environmental Claims, Terms and Definitions
14022	EL – Self-Declaration, Environmental Claims, Symbols
14023	EL – Self-Declaration, Environmental Claims, Testing and Verification Methodologies
14024	EL – Practitioner Programs: General Principles, Practices and Certification Procedures of Multiple Criteria Programs
14025	Type III Environmental Labelling
14031	Environmental Performance Evaluation
14040	LCA – General Principles and Guidelines
14041	LCA – Inventory Analysis
14042	LCA – Impact Assessment
14043	LCA – Interpretation
14050	Terms and Definitions
14060	Guide for the Inclusion of Environmental Aspects in Product Standards

EMS – Environmental Management System

EA – Environmental Auditing

EL – Environmental Labels and Declarations

LCA – Life Cycle Assessment

APPENDIX II: SCOPE OF GENERIC PLASTICS MANUFACTURING PROCESSES USED IN CANADA

113

Process	Major Resins Used
Film extrusion	PE, PP, PS, Nylon
Injection moulding	PE, PP, PVC, PS, ABS, PET, Nylon, Acrylic
Profile extrusion	PE, PVC, PS, ABS, Nylon
Sheet extrusion	PVC, PE, PS, ABS, PP, Acrylic
Foam extrusion	PS, PE, Phenolic
Calendered sheet extrusion	PVC, PS, PE, Acrylic, ABS
Plastisol processing	PVC
Rotational moulding	PE, PP
Blow moulding	PE, PP, PET, PVC
Lamination, film	PE, Nylon, PET
Lamination, thermoset	Phenolic, Urethane, Polyester
Compression moulding	Phenolic, U-F, M-F
Spray/pour	Urethanes
Open moulding	Urethanes, Phenolic, U-F
Filament winding	Polyester, Epoxy
Pultrusion	Polyester, Epoxy
Matched die moulding	Urethanes, Polyester, Phenolic

Source: Law, Sigurdson and Associates, 1993.

APPENDIX III: SELECTED CASE STUDIES FROM *IMPROVING ENERGY EFFICIENCY AT U.S. PLASTICS MANUFACTURING PLANTS*

The Society of the Plastics Industry Inc. and the U.S. Department of Energy published a series of case studies in the publication *Improving Energy Efficiency at U.S. Plastics Manufacturing Plants* (September 2005). Below is a summary of a selection of these case studies. For more details, visit www.eere.energy.gov/industry/bestpractices/iac_tools_and_publications.html.

Case Study Title	Summary
Precise Technology, Inc.	Total savings of \$105,000, reducing total energy use by 22 percent. Areas of improvement included lighting, compressed-air system, HVAC and motors.
Spartech Plastics	Total savings of \$113,000. Areas of improvement included heat recovery, lighting and insulation.
Superfos Packaging	Total savings of \$100,000, reducing total energy use by approximately 13 percent. Areas of improvement included machine insulation, motor management, compressed-air system and lighting.