



Transport  
Canada

Transports  
Canada



TP 127E  
(09/2007)

# SHIPS ELECTRICAL STANDARDS



TC-1002414



Canada

<p><b>Responsible Authority</b></p> <p>The Director of Construction and Equipment Standards is responsible for this document, including any change, correction, or update.</p> <p>Victor Santos-Pedro Director, Construction and Equipment Standards</p>	<p><b>Approval</b></p> <hr/> <p>Santos Pedros Director General, Marine Safety</p> <p>Date: _____</p>
--	--

**Date Issued: September 28, 2007**  
**Date Revised: September 28, 2007**  
**Last Review: February 2002**

NOTE: REVISIONS TO THE STANDARDS SINCE THE FEBRUARY 2002 AMENDMENT ARE INDICATED IN BOLD PRINT

Amendments made to this Standard TP 127 shall apply only to the following;

- (a) new vessel construction; or
- (b) vessels coming into Canadian Registry; or
- (c) where at the time substantial reconstruction or modifications to installations, equipment or appliances is carried out on an existing installation.

The implementation date of these amendments shall be the date issued indicated on the cover page of the Ship Electrical Standards

© Her Majesty the Queen in Right of Canada, as represented by the Minister of Transport, 2002.

Permission is granted, by Transport Canada, to copy this TP 127E as required. While use of this material has been authorized, Transport Canada shall not be responsible for the manner in which the information is presented, nor for any interpretations thereof. This TP 127E may not be updated to reflect amendments made to the original content. For up-to-date information, contact Transport Canada.

Catalogue No. T29-30/2007E  
ISBN 978-0-662-47057-1

TP 127E  
(09/2007)

TC-1002414

## DOCUMENT INFORMATION

<b>Title</b>	<b>SHIPS ELECTRICAL STANDARDS</b>		
<b>TP No.</b>	<b>127E</b>	<b>Edition</b>	<b>09/2007</b>
<b>Catalogue No.</b>	<b>T29-30/2007E</b>	<b>ISBN</b>	<b>978-0-662-47057-1</b>
<b>Originator</b>	Design, Equipment and Boating Safety Tower C, Place de Ville 330 Sparks Street, 11 <sup>th</sup> Floor Ottawa, Ontario - K1A 0N8	<b>Telephone</b>	(613) 991-6003
		<b>Fax</b>	(613) 991-4818
		<b>E-mail</b>	<a href="mailto:MarineSafety@tc.gc.ca">MarineSafety@tc.gc.ca</a>
		<b>URL</b>	<a href="http://www.tc.gc.ca/MarineSafety">http://www.tc.gc.ca/MarineSafety</a>

## REVISIONS

<b>Last Review</b>				
<b>Next Review</b>				
AMENDMENT No.	EFFECTIVE	SECTION/S	AUTHORITY	ENTERED BY
CMAC1993	FEB. 03,1995	LETTER 03,02,1995		J. KIRBY
No.1	MAR. 16, 1996		REVISIONS DUE TO "INCORPORATION BY REFERENCE" BY REGULATION	J. KIRBY
		Cvr Pgs 1&2 Tbl Cont'ts. Interp, Applic Schd 1,Schd 2, 1 (5,6,13), 2 (6,7,8), 3 (21), 6 (1), 9 (2,8,11,16,29,33,34), 10 (2,3,6), 11 (25), 12 (1,2,3,4), 13 (21,39,43), 14 Table(F), 16 (31), 17 (4), 18 (18,21), 19 (1), 20 (9), 21 (6)(a)(xx),(b)(vi),(c)(ii,iii,iv), (7)(b), 22 (6,18), 24 (29), 25 (14,18), 26 (2,3,4,5,6,7,8,11,15,16,18,20, 21,23), 27(1,2), 30 (1), 33 (13), 34 (2,4), 36 (1,2), 51 (4), 54 (1,3), 57 (5)		

AMENDMENT No.	EFFECTIVE	SECTION/S	AUTHORITY	ENTERED BY
No.2 CMAC 1997	October 06,1997		CMAC Technical meeting May 1997	J. Kirby
		Cvr Pages 1& 2 Interpretation Application (3) (b) (i), 5 Schedule 1 S1.1S1.2.2 (c) (i), (d) (iii).1.2.4 (a) (i) S1..3.3, S1.3.4 (b),(e),(g),(h) S1.4.1 (a) S1.5.2 (c) (i) S1.6.1 (a),(b),(c) S1.6.2 (c), S1.6.3 S1.7.1 (a),(b),(c) S1.7.2(c), S1.7.3 S1.8.1 (a),(b),(c) S1.8.2 (c), S1.8.3 1.7 3.23 4.2(h), 4.4, 4.5 7.1 9.26, 9.32 10.1, 10.2, 10.3 10..5 11.10, 11.12, 11.18, 11.19, 11.30, 11.37(c)(iii), (d),(f),(g), 12.1, 12.2, 12..3, 12.4, 12.5, 12.6, 12.7, 12.8, 12.9, 12.10, 12.11,12.12, 12.13} 13 Table E, 13.44, 13.45,13.46, 15.11 16.15, 16.30,,16.34, Table H & I 19.1.1, 19.2.1, 19.3.1, 19.3.4, 19.3.6, 19.4.3, 19.4.6, 19.4.7 19.4.8, 19.4.10, 19.5.3,19.6.1, 19.7.4, 21.1(c), 21.4.1, 21.4.2, 21.4.3, 21.4.4, 21.5.1, 21.5.2, 21.5.3, 21.5.4, 21.5.5, 21.6.2 (ii), (iii), (iv), (v), (vii), (viii), (x), (xiii), (xiv), (xv) (xvi), (xvii), (xxii), (xxiii), (xxiv), 21.6.3 (i), (ii), (vi), 21.7(f),(h) 22.10 23.2, 23.8 26.4(c), 26.17 51.2, 51.4, 51.7 53.25 5.1 56.1, 56.8 57.6 58.7		

AMENDMENT No.	EFFECTIVE	SECTIONS	AUTHORITY	ENTERED BY
No 3 CMAC			CMAC Technical Meeting November 2000	
		Cover pages 1 & 2 Interpretation Application (2) (d), (5) Schedule: 1 S 1.2.3,(c) 1.2.4 (a) (i), 1.3.2(c) 1.3.5(a), 1.4.5 1.5.3(c), 1.5.4 1.6..1(c), 1.6.2(a),(b), 1,6,3 1.7.1(c), 1.7.2(a),(c), 1.7.3 1.8.1(c), 1.8.2(a),(c), 1.8.3 2.7, 2.8, 2.15 3.21, 3.22 5.2, Table 5-1 7.6 Section 9, 9.3.12, 9.4.1, 9.4.2, 9.4.20 10.1, 10.2 11.12, 11.13, 11.23, 11.37, 11.39, 11.43, 11.45, Figures 11-1, 11-2 12.1, 12.3, 12.4, 12.5, 12.6, 12.7, 12.8, 12.9, 12.15, 12.16.,12.17, 13.4, 13.22, 13.40, 13.47 19.4.9, 19.4.10, 19.5.10, 19.5.11 20.1 21.1, 21.6.3(vi), 21.7 25.21, 25.22, 25.23, 25.24 27.1 28.2 33.8 34.11 35.2(k) Section37 54.1 55.3, 55.11		
No 4		3.2 Section 26	CMAC Technical Meeting May 2001	J. F. Kirby
No. 5	Sept. 28, 2007	Cover pages 1&2 S1.4.5 English Version only 2.8, 215 13.40 (a) 19.4.9 20.1 22.18 37.5		

# **TABLE OF CONTENTS**

---

<b>SHIP ELECTRICAL STANDARDS .....</b>	<b>vi</b>
<b>APPLICATION.....</b>	<b>ix</b>
<b>EMERGENCY ELECTRICAL POWER.....</b>	<b>x</b>
<b>SCHEDULE 2.....</b>	<b>xxi</b>
<b>PART 1.....</b>	<b>1</b>
<b>1. General Requirements for Ships of Groups 1 to 5B .....</b>	<b>1</b>
<b>2. Design of Equipment.....</b>	<b>3</b>
<b>3. Installations, Location and Protection of Electrical Equipment.....</b>	<b>5</b>
<b>4. Grounding of Non-Current-Carrying Parts.....</b>	<b>7</b>
<b>5. Application of Demand Loads .....</b>	<b>9</b>
<b>6. Direct Current Service Systems for Ships other than Tankers .....</b>	<b>10</b>
<b>7. Alternating Current Service Systems.....</b>	<b>11</b>
<b>8. System Protection – General.....</b>	<b>12</b>
<b>9. Switchboards Other Than Propulsion Control Panels Section 9.....</b>	<b>17</b>
<b>10. Switchgear and Fusegear.....</b>	<b>24</b>
<b>11. Distribution.....</b>	<b>26</b>
<b>12. Construction of Cables .....</b>	<b>33</b>
<b>13. Installation of Cables .....</b>	<b>38</b>
<b>14. Transformers for Power and Lighting.....</b>	<b>43</b>
<b>15. Static Power Supply Units.....</b>	<b>45</b>
<b>16. Generating Plant and Motors .....</b>	<b>46</b>
<b>17. Control Gear.....</b>	<b>51</b>
<b>18. Lighting Fixtures.....</b>	<b>54</b>
<b>19. Accumulators / Storage Batteries .....</b>	<b>56</b>
<b>20. Heating and Cooking Appliances .....</b>	<b>59</b>
<b>21. Interior Communications &amp; Alarms.....</b>	<b>60</b>
<b>22. Control and Instrumentation.....</b>	<b>67</b>
<b>23. Lightning Conductors.....</b>	<b>69</b>

24. Electric Propulsion Plant.....	70
25. Additional Requirements for AC Supply Systems with Voltages of 1 kV and Above .....	73
26. Hazardous Locations .....	75
27. Testing & Inspection at Manufacturer’s Plant .....	87
28. Testing Rotating Machines.....	88
29. Testing Switchboards and Motor Control Centres .....	90
30. Testing Main Propulsion Cables.....	91
31. Testing Transformers for Lighting and Power .....	92
32. Testing Static Power Supplies.....	93
33. Initial Testing and Inspection Onboard Ship .....	94
34. Periodic Inspections .....	97
35. Essential Services .....	99
36. Drawings and Data for Submission .....	100
37. Distribution Panels and Sub-Distribution Assemblies other than Switchboards for Distribution or Propulsion.....	101
<b>PART II.....</b>	<b>102</b>
Electrical Systems Less Than 50 Volts .....	102
50. Types of Systems .....	102
51. System Protection.....	103
52. Equipment Grounding.....	104
53. Lightning Conductors.....	105
54. Electrical Equipment .....	106
55. Batteries .....	107
56. Cables .....	108
57. Switchboards & Distribution Panels .....	109
58. Distribution.....	110

# **SHIP ELECTRICAL STANDARDS**

---

## **SHORT TITLE**

These Standards may be cited as the *Ship Electrical Standards*.

## **Interpretation**

### **In these Standards,**

“accommodation spaces” includes public spaces, corridors, lavatories, cabins, offices, crew quarters, isolated pantries and lockers;

“alarm” means the audible and/or visual signal given when a device or system operates outside a predetermined parameter;

“Board” means the Board of Steamship Inspection

“branch circuit” means that portion of a wiring system extending beyond the final overcurrent device protecting the circuit;

“certified” in respect to electrical equipment means certified or listed by a certifying authority;

“certifying authority” means a testing laboratory or facility which are listed in Schedule 2 of this standard;

“certified safe” equipment has been certified safe by a certifying authority for use in a particular hazardous atmosphere;

“communication circuit” means a circuit(s) whereby audible and/or visual information is transferred from one device to another within the vessel;

“continuous rating” are machines suitable for continuous duty at their full rated output at maximum cooling air or water temperature for an unlimited period;

“C.S.A.” means the *Canadian Standards Association*;

“drip-proof equipment” means that the equipment is so constructed that drops of falling liquids have no harmful effect when the equipment is tilted at any angle up to 15 degrees from the vertical;

“demand factor” means the ratio of the estimated consumption of a group of power-consuming apparatus under normal working conditions to the sum of the normal full-load ratings;

“explosion-proof or flame-proof” means, when used in reference to an enclosure, an enclosure that is capable of withstanding without damage, an explosion of a specified gas or vapour that may occur within it, and be capable of preventing the ignition of a specified gas or vapour surrounding the enclosure from sparks, flashes or explosion of the specified gas or vapour within the enclosure;

“factory sealed” refers to an explosion-proof device which is so constructed that external seals are not required;

“flame-retardant” when applied to a material means that the material will not burn for more than a specified period of time nor will the flame travel nor extend beyond a specified distance, as determined under certain test conditions at normal atmospheric pressure;

“hazardous locations” means locations in which explosive accumulations of gases, mixtures or highly flammable substances may be present;



Gas-dangerous space or zone means,

- (i) a space in the cargo area which is not arranged or equipped in an approved manner to ensure that its atmosphere is at all times maintained in a gas-safe condition.
- (ii) an enclosed space outside the cargo area through which any piping containing liquid or gaseous products passes, or within which such piping terminates, unless approved arrangements are installed to prevent any escape of product vapour into the atmosphere of that space;
- (iii) a cargo containment system or cargo piping;
- (iv.i) a hold space where cargo is carried in a cargo containment system requiring a secondary barrier;
- (iv.ii) a hold space where cargo is carried in a cargo containment system not requiring a secondary barrier;
- (v) a space separated from a hold space described in 4.1 by a single gastight barrier;
- (vi) a cargo pump-room and cargo compressor room;
- (vii) a zone on the open deck, or semi-enclosed space on the open deck, within 3m of any cargo tank outlet, gas or vapour outlet, cargo pipe flange or cargo valve or of entrances and ventilation openings to cargo-pump-rooms and cargo compressor rooms;
- (viii) the open deck over the cargo area and 3m forward and aft of the cargo area on the open deck up to a height of 2.4m above the weather deck;
- (ix) a zone within 2.4m of the outer surface of a cargo containment system where such surface is exposed to the weather;
- (x) an enclosed or semi-enclosed space in which pipes containing products are located;
- (xi) a compartment for cargo hoses; or
- (xii) an enclosed or semi-enclosed space having a direct opening into any gas-dangerous space or zone.

Gas-safe space means, a space other than a gas-dangerous space.

Gas-tight means, the specific quality of a physical barrier to prevent any significant quantity of flammable gas or vapour from entering into an adjoining space.

“IEC” means the International Electrotechnical Commission

“IEEE 45” means to the Institute of Electrical and Electronic Engineers Recommended Practice for Electrical Installations on Shipboard.

“increased safety apparatus” means apparatus designed to prevent, in normal working conditions, sparking or arcing and to avoid dangerous temperature rises reached by any part in contact with the explosive mixture; this implies that the construction is such that the risk of sparking or of abnormal temperature rises be very much less than for the standard-type industrial equipment;

“intrinsically safe” means electrical equipment that is so constructed that when installed and operated under the conditions specified by the certifying authority, any electrical sparking that may occur in normal and fault conditions either in the equipment or in the circuit associated therewith, is incapable of causing an ignition within a particular flammable gas or vapour;

“intrinsically safe circuit” means a circuit in which any electrical sparking that may occur in normal and fault conditions specified by the certifying authority, and with the specified components, is incapable of causing an ignition within a particular flammable gas or vapour;

“loop circuit” refers to a circuit of an addressable fire detection system whereby the circuit is capable of being interrogated from either end;

“machinery space” means any space containing propelling machinery, boilers, oil fuel units, steam and internal combustion engines, generators and major electrical machinery, oil filling stations, refrigerating, stabilizing, ventilation and air conditioning machinery and trunks to such spaces;

“machinery spaces of Category A” means all spaces, and trunks to such spaces, which contain:

- (i) internal combustion type machinery used for main propulsion, or other purposes where such machinery has in the aggregate a total power output of not less than 373 kW; or
- (ii) any oil-fired boiler or oil fuel unit;

“main fire control station” refers to a control station in which the control and indication functions for the fire detection and alarm system, fire door indicator and control panel, water tight door controls and indication, general alarm, public address, telephone systems and accommodation and vehicular ventilation controls and indication are centralized;

“monitoring systems” refers to a system which gathers and displays information concerning the operation of machinery or a system;

“NFPA” means the National Fire Protection Association

“public spaces” refers to spaces in the accommodation which include bars, dining rooms, halls, libraries, lounges, nurseries, recreation rooms and smoke rooms;

“recognized Classification Society” means the American Bureau of Shipping, Det Norske Veritas, or Lloyds Register of Shipping.

“safety system” refers to a system whereby arrangements to reduce power or shutdown any machine or system which could result in damage, breakdown or hazardous conditions;

“semi-enclosed” locations means locations where natural conditions of ventilation are notably different from those on open decks due to the presence of structures such as deckheads, windbreaks and bulkheads and which are so arranged that the dispersion of gas may not occur.

“service spaces” refers baggage rooms, galleys, laundries, mail rooms, main pantries with cooking facilities, store rooms and workshops clear of machinery spaces and the trunkways leading to such spaces;

“special category spaces” means those enclosed spaces above or below the bulkhead deck intended for the carriage of motor vehicles with fuel in their tanks for their own propulsion; into and from which such vehicles can be driven and to which passengers have access;

“totally enclosed” means that a machine is so enclosed as to prevent the exchange of air between the inside and outside of the case but not sufficiently enclosed to be termed airtight;

“U.L.” means Underwriters’ Laboratories;

“valve regulated sealed battery” refers to a battery which reduces the amount of gas released through a pressure relief valve by recombining the products of electrolysis, in this type of battery the electrolyte cannot be replaced;

“vented battery” refers to a battery in which electrolyte can be replaced and releases gas during the charging process;

“watertight” means an enclosure constructed so that a stream of water from a hose not less than 13 millimetres in diameter under a head of 11 metres from a distance of 3 metres can be played on the enclosure from any direction for a period of 15 minutes without leakage;

“weatherproof” means that equipment is so constructed or protected that exposure to the weather, to falling moisture or to external splashing, will not impair the effectiveness of the enclosed equipment.

“zone circuit” refers to a circuit of a fire detection system whereby the circuit to which the devices are connected terminates at the last device with an end of line load;

# APPLICATION

---

- (1) These Standards have been established by the Department of Transport and set out;
  - (a) minimum standards of safety for electrical equipment, installations and appliances; and
  - (b) the requirements of first and periodic inspections
- (2) Where TP 127 does not set out specific requirements in respect of the design, construction, installation or inspection of electrical equipment, these codes, rules and standards should be consulted for guidance as to the appropriate safety standards that are accepted by the marine industry:
  - (a) the most recent rules of IEEE STD 45 Recommended Practice for Electrical Installations on Shipboard;
  - (b) the most recent rules of IEC Publication 92 “Electrical Installations in Ships”;
  - (c) the most recent rules of a recognized Classification Society; or
  - (d) the most recent rules or codes issued by Societies or Administrations, other than recognized Classification Societies.
- (3) For the purpose of these Standards, ships shall be divided into the following groups:
  - (a) Group I – passenger ships that are certified to make voyages as follows:
    - (i) foreign,
    - (ii) home-trade, Class I,
    - (iii) home-trade, Class II,
    - (iv) home-trade, Class III, on international voyages,
    - (v) home-trade, Class III, other than on international voyages, where the length of the ship exceeds 61 metres,
    - (vi) inland waters voyages where the length of the ship exceeds 61 metres, or
    - (vii) minor waters voyages Class I, where the length of the ship exceeds 91.4 metres;
  - (b) Group 2 – passenger ships certified to make voyages as follows:
    - (i) home-trade, Class III, other than those referred to in Group I, and where the length of the ship exceeds 18.3 metres but does not exceed 61 meters , or,
    - (ii) inland waters voyages where the length of the ship exceeds 30.5 metres but does not exceed 61 metres, or
    - (iii) minor waters voyages, Class I, where the length of the ship exceeds 30.5 metres but does not exceed 91.4 metres;
  - (c) Group 3 – passenger ships that are not included in either Group 1 or 2;
  - (d) Group 4 – Safety Convention cargo ships that carry not more than twelve passengers;
  - (e) Group 5 – Cargo ships that are not included in Group 4.
  - (f) Group 5A – Large Fishing Vessels;
  - (g) Group 5B – Small Fishing Vessels.
- (4) The electrical equipment and installations on board ship shall be such that:
  - (a) the services essential for safety shall be maintained under various emergency conditions; and
  - (b) the ship and all persons on board are protected against electrical hazards in accordance with the requirements of these Standards.
- (5) Part II of this Standard shall only apply to vessels in which the main electrical distribution system is less than a nominal voltage of 50 Volts.

# **EMERGENCY ELECTRICAL POWER**

## **S1.1. Emergency Electrical Distribution System Configuration**

S1.1.1 The emergency electrical distribution systems for all vessels Groups 1 through and including 5 (b) shall be considered standard as follows:

- (a) Alternating Current Systems:
  - (i) 3-phase, 3-wire insulated system;
  - (ii) single phase, 2 wired insulated system,
- (b) For Direct Current Systems, 2 wire insulated systems.

## **S1.2 Emergency Electrical Power in Ships of Group 1**

- S1.2.1 (a) Every ship of Group 1 shall be provided with a self-contained emergency source of electrical power:
- (b) the emergency source of power, associated transforming equipment, if any, the transitional source of emergency power and the emergency switchboard shall be located above the upper-most continuous deck and shall be readily accessible from an open deck; they shall not be forward of the collision bulkhead;
  - (c) the location of the emergency source of power, associated transforming equipment, if any, the transitional source of emergency power, and the emergency switchboard in relation to the main source(s) of electrical power shall be such that a fire, or other casualty, in the space containing the main source(s) of electrical power or in any machinery space of Category A will not interfere with the supply or distribution of emergency power; as far as practicable, the space containing the emergency source of power, the transitional source of emergency power, and emergency switchboard shall not be contiguous to the boundaries of machinery spaces of Category A or those spaces containing the main source(s) of electrical power; and
  - (d) provided that suitable measures are taken for safeguarding independent emergency operation under all circumstances, the emergency generator may be used exceptionally, and for short periods, to supply non-emergency circuits.

- S1.2.2 The power available shall be sufficient to supply all those services that are essential for safety in an emergency, due regard being paid to such services as may have to be operated simultaneously; the emergency source of power shall be capable, having regard to starting currents and the transitory nature of certain loads, of supplying simultaneously at least the following services for the periods specified hereinafter, if they depend upon an electrical source for their operation:
- (a) for a period of 36 hours, emergency lighting at every muster and embarkation station on deck and over sides and in alleyways, stairways and exits giving access to the muster and embarkation stations,
  - (b) for a period of 36 hours, emergency lighting:
    - (i) in all service and accommodation alleyways, stairways and exits, personnel elevators,
    - (ii) in the machinery spaces and main generating stations including their control positions,
    - (iii) in all control stations, and in all machinery control rooms, radio rooms/stations and at each main and emergency switchboard;
    - (iv) at the stowage position(s) for firemen's outfits;
    - (v) at the steering gear; and
    - (vi) at the sprinkler pump, at the fire pump, at the emergency bilge pump, and at the starting positions of their motors;

- (c) for a period of 36 hours:
    - (i) the alternate system of navigation lights and other lights required by the Collision Regulations; and
    - (ii) the VHF, MF, MF/HF radio installations and the ship earth station required by the Ship Station Radio Regulations.
  - (d) for a period of 36 hours:
    - (i) all internal communication equipment that is required in an emergency;
    - (ii) shipborne navigational equipment as required by the Navigating Appliances and Equipment Regulations;
    - (iii) fire detection and its alarm system, and fire door holding, indication and release system; and
    - (iv) intermittent operation of the daylight-signalling lamp, the ship's whistle, the manual fire alarms and all internal signals that are required in an emergency, unless they have an independent supply from an accumulator battery suitably located for use in an emergency and sufficient for the period of 36 hours;
  - (e) for a period of 36 hours one of the fire pumps;
  - (f) for a period of 36 hours the automatic sprinkler pump, if any;
  - (g) for a period of 36 hours the emergency bilge pump and all equipment essential for the operation of electrically powered remote controlled bilge valves;
  - (h) the operation of the steering gear for a period of time required by Schedule (VII) of the Marine Machinery Regulations;
  - (i) for a period of half an hour the watertight doors which are required to be power operated together with their indicators and warning signals; where sequential operation of the doors is provided all doors shall be closed within 60 seconds; and
  - (j) for a period of half an hour the emergency arrangements that will cause the elevator(s) to deck for the escape of passengers or crew; sequential emergency decking of the passenger elevator(s) is permitted.
- S1.2.3 In the case of ships engaged regularly on voyages of short duration, a lesser period than the 36 hour period specified will be considered by the board provided that:
- (a) in no case is it less than 12 hours;
  - (b) the level of safety is maintained and;
  - (c) information in respect of the vessel, its voyage and the life saving and fire fighting equipment it carries is submitted to the Board for inspection.
- S1.2.4 The emergency source of power may be either a generator or an accumulator battery:
- (a) where the emergency source of power is a generator it shall be:
    - (i) driven by a suitable prime-mover with an independent supply of fuel having a flashpoint of not less than 43°C; and equipped with a starting arrangement as per Part 1 Section 1 (1.6 to 1.10) of this standard; or
    - (ii) started automatically upon failure of the electrical supply from the main power source(s) and shall be automatically connected to the emergency switchboard; those services referred to in paragraph shall then be transferred automatically to the emergency generator; the automatic starting system and the characteristic of the prime-mover shall be such as to permit the emergency generator to carry its full rated load as quickly as is safe and practicable, but in no more than 45 seconds; and

- (iii) provided with a transitional source of emergency power according to subsection S1.2.5 of this Standard.
  - (b) where the emergency source of power is an accumulator battery it shall be capable of:
    - (i) carrying the emergency load without recharging whilst maintaining the voltage of the battery throughout the discharge period within plus or minus 12 per cent of its nominal voltage;
    - (ii) automatically connecting to the emergency switchboard in the event of failure of the main power supply; and
    - (iii) immediately supplying at least those services specified in subsection S1.2.5.
- S1.2.5 The transitional source of emergency power required by subparagraph S1.2.4 (a) (iii) shall consist of an accumulator battery suitably located for use in an emergency which shall operate without recharging whilst maintaining the voltage of the battery throughout the discharge period within plus or minus 12 per cent of its nominal voltage and be of sufficient capacity and so arranged as to automatically supply in the event of failure of either the main or emergency source of power at least the following services, if they depend upon an electrical source for their operation:
- (a) for half an hour:
    - (i) the lighting required by paragraphs S1.2.2 (a), (b) and (c);
    - (ii) all essential internal communication equipment, fire detecting and its alarm system, and the fire door holding and release equipment required by S1.2.2 (d) (i) and (iii); and
    - (iii) intermittent operation of the services required by subparagraph S1.2.2 (d) (iv); unless, in respect of (ii) and (iii) above, they have an independent supply from an accumulator battery suitably located for use in an emergency and sufficient for the period specified;
  - (b) power to close the watertight doors but not necessarily to close them all simultaneously;
  - (c) the indicators which show whether power-operated water-tight doors are open or closed; and
  - (d) the sound signals which give warning that the power-operated watertight doors have begun to close.
- S1.2.6 The emergency switchboard shall be installed as near as is practicable to the emergency source of power.
- S1.2.7 Where the emergency source of power is a generator, the emergency switchboard shall be located in the same space unless the operation of the emergency switchboard would thereby be impaired.
- S1.2.8 No accumulator battery fitted in accordance with this Standard shall be installed in the same space as the emergency switchboard; an indicator shall be mounted in a suitable place on the main switchboard or in the machinery control room to indicate when the batteries constituting either the emergency source of power or the transitional source of power referred to in paragraph S1.2.4 (b) or subsection S1.2.5 are being discharged.
- S1.2.9 The emergency switch board is to be supplied in normal operation from the main switchboard by an interconnector feeder which is to be adequately protected at the main switchboard against overload and short circuit, the arrangement at the emergency switchboard shall be such that the interconnector feeder is disconnected automatically at the emergency switchboard upon failure of the main power supply; where the system is arranged for feedback operation, the interconnector feeder is also to be protected at the emergency switchboard at least against short circuit.
- S1.2.10 In order to ensure ready availability of emergency supplies, arrangements shall be made where necessary to disconnect automatically non-emergency circuits from the emergency switchboard to ensure that power shall be available to the emergency circuits.

- S1.2.11 The emergency generator and its prime-mover and any emergency accumulator battery shall be so arranged as to ensure that it will function at full rated power when it is upright and when inclined at any angle of list up to and including 22½ degrees either way or up to and including 10 degrees inclination either way in the fore and aft direction, or is in any combination of angles within those limits.
- S1.2.12 Provision shall be made for the periodic testing of the complete emergency system and shall include the testing of automatic starting arrangements.

### **S1.3 Emergency Electrical Power in Ships of Group 2**

- S1.3.1 Every ship of Group 2 shall have a self-contained emergency source of electrical power that shall be:
- (a) located above the bulkhead deck outside the machinery casings and aft of the collision bulkhead; and
  - (b) so located in relation to the main source of electrical power as to ensure that a fire or other casualty in the machinery space will not interfere with the supply or distribution of emergency power.
- S1.3.2 The emergency source of electrical power shall be adequate for a period of twelve hours except that, in the case of a ship engaged regularly on voyages of short duration, a lesser period than the 12 hour period will be considered by the Board provided that:
- (a) in no case is it less than 6 hours;
  - (b) the level of safety is maintained and;
  - (c) information in respect of the vessel its voyage and life saving and fire fighting equipment it carries is submitted to the Board for inspection.
- S1.3.3 Emergency lighting shall be provided for the illumination, at every muster, embarkation station and oversides, all alleyways, stairways, exits and machinery spaces, the emergency generator space and all control stations containing radio, main navigating equipment and central fire recording equipment.
- S1.3.4 The emergency power shall be capable of operating simultaneously the following equipment in all cases where that equipment is electrically operated and required by any Regulations made under the Act:
- (a) the emergency lighting required by subsection S1.3.3;
  - (b) the alternate system of navigation lights, if solely operated by electrical power;
  - (c) the emergency bilge pump, if electrically operated,
  - (d) the general alarm system;
  - (e) the fire detection and its alarm system; and fire door holding, indication and release system: and
  - (f) the ship's radio station, if the vessel is equipped with an emergency generator; and
  - (g) the operation of the steering gear for a period of time, where required by Schedule (VII) of the Marine Machinery Regulations; and
  - (h) for a period of half an hour the watertight doors, which are required to be power operated together with their indicators and warning signals; where sequential operation of the doors is provided all doors shall be closed within 60 seconds.

- S1.3.5 The emergency source of electrical power may be either:
- (a) a generator driven by a suitable prime mover with an independent fuel supply using fuel having a flashpoint of not less than 43°C and equipped with a starting arrangement as per Part 1 Section 1 (1.6 to 1.10) of this standard; or
  - (b) storage batteries capable of carrying the emergency load without recharging or excessive voltage drop.
- S1.3.6 The emergency switchboard shall be installed as near as is practicable to the emergency source of electrical power except that storage batteries shall not be fitted in the same space as the emergency switchboard.
- S1.3.7 The emergency switchboard shall be supplied from the main switchboard during normal operation.
- S1.3.8 Provision shall be made for the periodic testing of the emergency source of electrical power and of automatic arrangements.

#### **S1.4 Emergency Electrical Power in Ships of Group 3**

- S1.4.1 Subject to subsection S1.4.2, every ship of Group 3, other than a small passenger ship certificated to operate only between sunrise and sunset, shall be provided with lights that are permanent or portable and that:
- (a) will illuminate every launching station, muster and embarkation station, stowage position of survival craft, passageway and exit; and
  - (b) can be supplied with electrical power from an emergency source described in subsection S1.4.4.
- S1.4.2 Every ship to which subsection S1.4.1 applies:
- (a) that is a launch of less than 30.5 metres in length; or
  - (b) that is a ship other than a launch and is less than 18.3 metres in length, may, in lieu of the lights required by subsection S1.4.1 be provided with non-rechargeable battery operated hand lanterns.
- S1.4.3 Where a ship to which subsection S1.4.1 applies is provided with lanterns pursuant to subsection S1.4.2, the batteries for the lanterns shall be replaced with new batteries annually and the lanterns shall be tested during every annual and intermediate inspection of the ship and at the time of every boat and fire drill.
- S1.4.4 Where a ship to which subsection S1.4.1 applies is provided with lights described in that subsection, the ship shall be provided with an emergency source of electrical power consisting of a rechargeable storage battery or batteries located outside the machinery space on the ship and capable of supplying power to the lights for a period of not less than one hour.
- S1.4.5 Where the alternate system of navigation lights is required to be supplied by an electrical source, **the system** shall be provided with an emergency source of power in accordance with S1.4.4

#### **S1.5 Emergency Electrical Power in Ships of Group 4**

- S1.5.1 (a) Every cargo ship of Group 4 shall be provided with a self-contained emergency source of electrical power;
- (b) The emergency source of electrical power, associated transforming equipment, if any, the transitional source of emergency power, the emergency switchboard, and the emergency lighting switchboard shall be located above the upper-most continuous deck and shall be readily accessible from an open deck; they shall not be forward of the collision bulkhead;
  - (c) The location of the emergency source of electrical power, associated transforming equipment, if any, the transitional source of emergency power, the emergency switchboard and the emergency lighting switchboard in relation to the main source(s) of electrical power, associated transforming equipment, if any, and the main switchboard shall be such that



a fire or other casualty in the space containing the main source(s) of electrical power, the associated transforming equipment, if any, and the main switchboard, or in any machinery space of Category A will not interfere with the supply, control and distribution of emergency power; as far as practicable the space containing the emergency sources of power, the associated transforming equipment, if any, the transitional source of emergency power and the emergency switchboard shall not be contiguous to the boundaries of machinery spaces of Category A or those spaces containing the main source(s) of electrical power, associated transforming equipment, if any, and the main switchboard; and

- (d) provided that suitable measures are taken for safeguarding independent emergency operation under all circumstances, the emergency generator may be used, exceptionally, and for short periods, to supply non-emergency circuits.

S1.5.2 The power available shall be sufficient to supply all those services that are essential for safety in an emergency, due regard being paid to such services as may have to be operated simultaneously; the emergency source of power shall be capable, having regard to starting currents and the transitory nature of certain loads, of supplying simultaneously at least the following services for the periods specified hereinafter, if they depend upon an electrical source for their operation:

- (a) For a period of 3 hours, emergency lighting at every muster and embarkation station on deck and over sides,
- (b) for a period of 18 hours, emergency lighting:
  - (i) in all service and accommodation alleyways, stairways and exits, personnel elevators and personnel elevator trunks;
  - (ii) in the machinery spaces and main generating stations including their control positions;
  - (iii) in all control stations, radio rooms/stations, machinery control rooms and at each main and emergency switchboard;
  - (iv) at the stowage position(s) for firemen's outfits;
  - (v) at the steering gear;
  - (vi) at the sprinkler pump if any, at the fire pump referred to in paragraph S1.5.2 (e) of this subsection, at the emergency bilge pump if any, and at their starting positions; and
  - (vii) navigating bridge and chart room;
- (c) for a period of 18 hours:
  - (i) the alternate system of navigation lights and other lights required by the Collision Regulations; and
  - (ii) the VHF, MF, MF/HF radio installations and the ship earth station required by the Ship Station Radio Regulations;
- (d) for a period of 18 hours:
  - (i) all internal communication equipment that is required in an emergency;
  - (ii) shipborne navigational equipment as required by the Navigating Appliances and Equipment Regulations;
  - (iii) fire detection and its alarm systems; and
  - (iv) intermittent operation of the daylight signalling lamp, the ship's whistle, the general alarm, the manual fire alarms, and all internal signals that are required in an emergency; unless, in respect of (i) (ii) (iii) and (iv) above, they have an independent supply from an accumulator battery suitably located for use in an emergency and sufficient for the period of 18 hours.

- (e) for a period of 18 hours one of the fire pumps required by Regulation 4 of Chapter II-2 of the International Convention for the Safety of Life at Sea, 1974 if dependent upon the emergency generator for its source of power; and
  - (f) the operation of the steering gear for a period of time required by Schedule VII of the Marine Machinery regulations.
- S1.5.3 In the case of a ship engaged regularly on voyages of short duration or a ship that is 500 tons gross tonnage or over but less than 5,000 tons a lesser period than the 18 hour period specified in paragraphs S1.5.2 (b), (c), (d) and (e) will be considered by the Board provided that:
- (a) in no case is it less than 12 hours;
  - (b) the level of safety is maintained and;
  - (c) information in respect of the vessel, its voyage, and the life saving and fire fighting equipment it carries is submitted to the Board, for inspection.
- S1.5.4 The emergency source of power may be either a generator or an accumulator battery:
- (a) where the emergency source of power is a generator it shall be:
    - (i) driven by a suitable prime mover with an independent supply of fuel, having a flashpoint of not less than 43°C and equipped with a starting arrangement as per Part 1 Section 1 (1.6 to 1.10) of this standard;
    - (ii) started automatically upon failure of the normal electrical supply unless a transitional source of emergency power in accordance with (iii) hereafter is provided; where the emergency generator is automatically started, it shall be automatically connected to the emergency switchboard; those services referred to in subsection S1.5.5 shall then be connected automatically to the emergency generator; and unless a second independent means of starting the emergency generator is provided the single source of stored energy shall be protected to preclude its complete depletion by the automatic starting system; and
    - (iii) provided with a transitional source of emergency power as specified in subsection S1.5.5 unless there is provided an emergency generator capable of supplying the services mentioned in subsection S1.5.5 and which is capable of being automatically started and supplying the required load as quickly as is safe and practicable but in not more than 45 seconds; and
  - (b) where the emergency source of power is an accumulator battery it shall be capable of:
    - (i) carrying the emergency load without recharging whilst maintaining the voltage of the battery throughout the discharge period within plus or minus 12 per cent of its nominal voltage;
    - (ii) automatically connecting to the emergency switchboard in the event of failure of the main power supply; and
    - (iii) immediately supplying at least those services specified in subsection (5).
- S1.5.5 The transitional source of emergency power where required by sub-paragraph S1.5.4 (a) (iii) shall consist of an accumulator battery suitably located for use in an emergency which shall operate without recharging whilst maintaining the voltage of the battery throughout the discharge period within plus or minus 12 per cent of its nominal voltage and be of sufficient capacity and so arranged as to automatically supply in the event of failure of either the main or emergency source of power for half an hour at least the following services if they depend upon an electrical source for their operation:

- (a) the lighting required by paragraphs S1.5.2 (a), (b) and (c); for this transitional phase, the required emergency lighting, in respect of the machinery space and accommodation and service areas, may be provided by permanently fixed, individual, automatically charged, relay operated battery lamps;
  - (b) all essential internal communication equipment, fire detection and its alarm equipment required by sub-paragraph S1.5.2 (d) (i); and
  - (c) intermittent operation of the services referred to in sub-paragraph S1.5.2 (d) (iv); unless, in respect of (b) and (c) above, they have an independent supply from an accumulator battery suitably located for use in an emergency and sufficient for the period specified.
- S1 5.6 (a) the emergency switchboard shall be installed as near as is practicable to the emergency source of power;
- (b) where the emergency source of power is a generator, the emergency switchboard shall be located in the same space unless the operation of the emergency switchboard would thereby be impaired;
- (c) no accumulator battery fitted in accordance with this Standard shall be installed in the same space as the emergency switchboard; an indicator shall be mounted in a suitable place on the main switchboard or in the machinery control room to indicate when the batteries constituting either the emergency source of power or the transitional source of power referred to in subsections S1.5.4 or S1.5.5 are being discharged;
- (d) the emergency switchboard is to be supplied in normal operation from the main switchboard by an inter-connector feeder which is to be adequately protected at the main switchboard against overload and short circuit; the arrangement at the emergency switchboard shall be such that the interconnector feeder is disconnected automatically at the emergency switchboard upon failure of the main power supply; where the system is arranged for feedback operation, the interconnector feeder is also to be protected at the emergency switchboard at least against short circuit; and
- (e) in order to ensure ready availability of emergency supplies, arrangements shall be made where necessary to disconnect automatically non-emergency circuits from the emergency switchboard to ensure that power shall be available automatically to the emergency circuits.
- S1.5.7 The emergency generator and its prime mover and any emergency accumulator battery shall be so arranged as to ensure that it will function at full rated power when it is upright and when inclined at any angle of list up to and including 22½ degrees either way or up to and including 10 degrees inclination either way in the fore and aft direction or is in any combination of angles within those limits.
- S1.5.8 Provision shall be made for the periodic testing of the complete emergency system and shall include the testing of automatic starting arrangements.

## **S1.6 Emergency Electrical Power in Ships of Group 5**

- S1.6.1 Subject to subsection S1.6.7 every ship of Group 5 shall have an emergency power source for the following services:
- (a) for a period of three hours the emergency lighting for:
    - (i) launching stations and stowage position of survival craft;
    - (ii) the ships sides at launching stations;
    - (iii) all alleyways;
    - (iv) stairways and exits;
    - (v) machinery spaces including tunnels and conveyor drive areas in self-unloaders;
    - (vi) navigating bridge;

- (vii) radio room/station;
  - (viii) at the stowage position(s) for firemen's outfits;
  - (b) for a period of three hours the alarm and communication systems as follows:
    - (i) general alarm system;
    - (ii) public address system; and
    - (iii) fire detection and its alarm system;
    - (iv) the ship's radio station, if the vessel is equipped with an emergency generator.
  - (c) for a period of three (3) hours the alternate system of navigation lights or task lights required to be fitted on the vessel in accordance with the Collision Regulations, in which the source of power shall be in accordance with either paragraph S1.6.2 (a) or (b) or S1.6.3
- S1.6.2 The emergency source of electrical power may be either:
- (a) a generator driven by a suitable prime mover with an independent fuel supply using fuel having a flashpoint of not less than 43°C and equipped with a starting arrangement in accordance with Part 1 Section 1 (1.6 to 1.10) of this standard; or
  - (b) storage batteries capable of carrying the emergency load without recharging or excessive voltage drop.
  - (c) the emergency sources of electrical power referred to in Section S1.6.2 (a) and (b) and all associated electrical equipment with that emergency source shall be located above the uppermost continuous deck and not contiguous to the boundaries of machinery spaces of Category A, accessible from the open deck; and not forward of the collision bulkhead;
- S1.6.3 The emergency power required for the items referred to in subsection S1.6.1 (b) and (c) may each be supplied from individual floated batteries for each system, provided the capacity is sufficient to operate the equipment for a period of time not less than three (3) hours.
- S1.6.4 The emergency lighting referred to in paragraph S1.6.1 (a) may be supplied by rechargeable or non-rechargeable portable or semi-portable battery operated lanterns.
- S1.6.5 In ships with non-rechargeable battery-operated hand lanterns, the batteries for the lanterns shall be replaced with new batteries annually.
- S1.6.6 The emergency power source and the complete emergency installation shall be tested annually, and in the case of non-rechargeable battery-operated hand lanterns, for a period of five minutes after the batteries have been replaced.
- S1.6.7 Small ships certificated to operate only between sunrise and sunset are not required to be provided with emergency lighting or equipment as required by subsection S1.6.1.

## **S1.7 Emergency Electrical Power in Ships of Group 5A**

- S1.7.1 Every ship of Group 5A shall have an emergency power source for the following services:
- (a) for a period of three (3) hours the emergency lighting for:
    - (i) launching stations and stowage position of survival craft;
    - (ii) the ships sides at launching stations;
    - (iii) all alleyways;
    - (iv) stairways and exits;
    - (v) machinery spaces;
    - (vi) navigating bridge;
    - (vii) radio room/station;

- (viii) at the stowage position(s) for firemen's outfits;
  - (ix) in enclosed fish handling and processing spaces;
  - (b) for a period of three (3) hours the alarm and communication systems as follows:
    - (i) general alarm system where fitted;
    - (ii) public address system where fitted;
    - (iii) fire detection system and its alarm system where fitted; and
    - (iv) the ship's radio station, if the vessel is equipped with an emergency generator.
  - (c) for a period of three (3) hours the alternate system of navigation lights or task lights required to be fitted on the vessel in accordance with the Collision Regulations, in which the source of power shall be in accordance with either paragraph S1.7.2 or S1.7.3.
- S1.7.2 The emergency source of electrical power may be either:
- (a) a generator driven by a suitable prime-mover with an independent fuel supply using fuel having a flashpoint of not less than 43°C and equipped with a starting arrangement in accordance with Part 1 Section 1 (1.6 to 1.10) of this standard; or
  - (b) storage batteries capable of carrying the emergency load without recharging or excessive voltage drop.
  - (c) the emergency sources of electrical power referred to in Section S1.7.2 (a) and (b) and all associated electrical equipment with that emergency source shall be located above the uppermost continuous deck and not contiguous to the boundaries of machinery spaces of Category A, accessible from the open deck; and not forward of the collision bulkhead;
- S1.7.3 The emergency power required for the items referred to in subsection S1.7.1 (b) and (c) may each be supplied from individual floated batteries for each system, provided the capacity is sufficient to operate the equipment for a period of time not less than three (3) hours.
- S1.7.4 The emergency lighting referred to in paragraph S1.7.1 (a) may be supplied or supplemented by rechargeable or non-rechargeable portable or semi-portable battery operated lanterns.
- S1.7.5 In ships with non-rechargeable battery operated hand lanterns; the batteries for the lanterns shall be replaced with new batteries annually.
- S1.7.6 The emergency power source and the complete emergency installation shall be tested annually, and in the case of non-rechargeable battery operated hand lanterns, for a period of five minutes after the batteries have been replaced.

## **S1.8 Emergency Electrical Power In Ships of Group 5B**

- S 1.8.1 Every ship of Group 5B which has a ship's service electrical system of 50 volts or over, shall have an emergency electrical power source for the following services:
- (a) for a period of three (3) hours the emergency lighting for:
    - (i) launching stations and stowage positions of survival craft;
    - (ii) the ships sides at launching stations;
    - (iii) all alleyways;
    - (iv) stairways and exits;
    - (v) machinery spaces;
    - (vi) navigating bridge;
    - (vii) radio room/station;
    - (viii) in enclosed fish handling and processing spaces;

- (b) for a period of three (3) hours the alarm and communication systems as follows:
    - (i) general alarm system if fitted;
    - (ii) public address system if fitted;
    - (iii) fire detection system and its alarm system if fitted; and
    - (iv) the ship's radio station, if the vessel is equipped with an emergency generator.
  - (c) for a period of three (3) hours the alternate system of navigation lights or task lights required to be fitted on the vessel in accordance with the Collision Regulations, in which the source of power shall be in accordance with either paragraph S1.8.2 (a) or (b) or S1.8.3
- S1.8.2 The emergency source of electrical power may be either:
- (a) a generator driven by a suitable prime-mover with an independent fuel supply having a flashpoint of not less than 43°C and equipped with a starting arrangement in accordance with Part 1 Section 1 (1.6 to 1.10) of this standard; or
  - (b) storage batteries capable of carrying the emergency load without recharging or excessive voltage drop.
  - (c) the emergency sources of electrical power referred to in Section S1.8.2 (a) and (b) and all associated electrical equipment with that emergency source shall be located above the uppermost continuous deck and not contiguous to the boundaries of machinery spaces of Category A, accessible from the open deck; and not forward of the collision bulkhead;
- S1.8.3 The emergency power required for the items referred to in subsection S1.8.1 (b) and (c) may each be supplied from individual floated batteries for each system, provided the capacity is sufficient to operate the equipment for a period of time not less than three (3) hours.
- S1.8.4 The emergency lighting referred to in paragraph S1.8.1 (a) may be supplied or supplemented by rechargeable or non-rechargeable portable or semi-portable battery operated lanterns.
- S1.8.5 In ships with non-rechargeable battery operated hand lanterns; the batteries for the lanterns shall be replaced with new batteries annually.
- S1.8.6 The emergency power source and the complete emergency installation shall be tested annually, and in the case of non-rechargeable battery operated hand lanterns, for a period of five minutes after the batteries have been replaced.

# **SCHEDULE 2**

---

## **CERTIFYING AUTHORITIES**

### **CANADA**

Canadian Standards Association (CSA)

Underwriters Laboratories of Canada (ULC)

National Research Council of Canada (NRC)

### **UNITED STATES OF AMERICA**

ETL Testing Laboratories Inc. (ETL)

Factory Mutual Research Corp. (FM)

M&T Laboratories

Underwriters Laboratories (UL)

United States Testing Company Inc.

### **EUROPE**

#### **GERMANY**

Physikalisch Technische Bundesanstalt (PTB)

#### **DEMARK**

Danmarks Eleltriske Materielkontrol (DEMKO)

#### **NORWAY**

Norges Elektriske Materiellkontrol(NEMKO)

#### **SWEDEN**

Svenska Elektriske Materielkontrollanstalten (SEMKO)

### **UNITED KINGDOM**

British Approvals Services for Electrical Equipment in Flammable Atmospheres (BASEEFA)

Electrical Equipment Certification Service (EECS)

# **PART 1**

---

## **1. GENERAL REQUIREMENTS FOR SHIPS OF GROUPS 1 TO 5B**

- 1.1 Electrical installations in ships of Group 1 to 5B shall be such that:
- (a) all auxiliary services necessary for maintaining the ship in normal operational and habitable conditions will be assured without recourse to the emergency source of power,
  - (b) services essential for safety will be assured under various emergency conditions; and
  - (c) the safety of passengers, crew and ship from electrical hazards will be assured.
- 1.2
- (a) every ship, the electrical power of which constitutes the only means of maintaining auxiliary services indispensable for the propulsion and safety of the ship, shall be provided with a main source of power which shall include at least two generating sets;
  - (b) the power of these sets shall be such that it shall still be possible to ensure the functioning of the services referred to in paragraph 1.1 (a) in the event of any one of these generating sets being stopped;
  - (c) the arrangements of the ship's main source of power shall be such that the services referred to in paragraph 1.1 (a) can be maintained regardless of the speed and direction of the main propelling engines or shafting;
  - (d) in addition, the generating plant shall be such as to ensure that with any one generator or its primary source of power out of operation, the remaining generator(s) will be capable of providing the electrical services necessary to start the main propulsion plant from a dead ship condition; the emergency generator may be used for the purpose of starting from a dead ship condition if its capability either alone or combined with that of any other generator is sufficient to provide at the same time those services required in an emergency; and
  - (e) where transformers constitute an essential part of the supply system required by this paragraph, the system shall be so arranged as to ensure the same continuity of the supply, as stated in this paragraph.
- 1.3
- (a) a main electric lighting system which shall provide illumination throughout those parts of the ship normally accessible to and used by the passengers or by the crew shall be supplied from the main source of power;
  - (b) the arrangement of the main lighting system shall be such that a fire or other casualty in the space(s) containing the main source of power, including transformers, if any, shall not render the emergency lighting system inoperative;
  - (c) the arrangement of the emergency lighting system shall be such that a fire or other casualty in the space(s) containing the emergency source of power, including transformers, if any, shall not render the main lighting system required by this Standard inoperative; and
  - (d) all emergency lights shall be marked with a red letter "E" at least 13 mm high.
- 1.4 The main switchboard shall be so placed relative to one main generating station that, as far as is practicable, the integrity of the normal supply may be affected only by a fire or other casualty in one space; an environmental enclosure for the main switchboard, such as may be provided by a machinery control room situated within the main boundaries of the space, is not to be considered as separating the switchboard from the generators.
- 1.5 In every ship where the total installed electrical power of the main generators is in excess of 3 megawatts, the main bus bars shall be subdivided into at least two parts which shall normally be connected by removable links or equivalent arrangements; so far as is practicable, the connection of generators and any other duplicated equipment shall be equally divided between the parts; equivalent alternative arrangements shall be permitted.



- 1.6 Emergency generating sets shall be capable of being readily started in their cold condition; if this is impracticable, or if lower temperatures are likely to be encountered, provision shall be made for the maintenance of heating arrangements, to ensure ready starting of the generating sets.
- 1.7 Each emergency generating set that is arranged to be automatically started shall be equipped with starting devices with a storage energy capability of at least three consecutive starts; the source of stored energy shall be protected to preclude critical depletion by the automatic starting system, unless a second independent means of starting is provided; a second source of energy is to be provided for an additional three starts within 30 minutes unless hand (manual) starting can be demonstrated to be effective.
- 1.8 The stored energy shall be maintained at all times, as follows:
  - (a) electrical and hydraulic starting systems shall be maintained from the emergency switchboard;
  - (b) compressed air starting systems may be maintained by the main or auxiliary compressed air receivers through a suitable non-return valve or by an emergency air compressor which, if electrically driven, is supplied from the emergency switchboard; and
  - (c) all of these starting, charging and energy storing devices shall be located in the emergency space; these devices are not to be used for any purpose other than the operation of the emergency generating set; this does not preclude the supply to the air receiver of the emergency generating set from the main or auxiliary compressed air system through the non-return valve fitted in the emergency generator space.
- 1.9 Where automatic starting is not required, manual starting is permissible, such as manual cranking, inertia starters manually charged hydraulic accumulators, or powder charge cartridges, where they can be demonstrated as being effective.
- 1.10 When manual starting is not practical, the requirements of subsections 1.7 and 1.8 shall be complied with except that starting may be manually initiated.
- 1.11 An indicator shall be provided in a suitable place on the main switchboard or in the machinery control room to indicate when the emergency generator is running.
- 1.12 Emergency generator/power equipment, control devices, and their associated wiring shall not be located in the same space as equipment and control devices which control, supply and distribute the main source of power unless the devices and equipment are arranged for "Fail Safe" operation; (i.e. failure of such equipment or devices would not affect the operation of the emergency power source).
- 1.13 Every passenger ship with open or enclosed ro-ro cargo spaces or special category spaces and which also has enclosed public areas shall be equipped with an supplementary emergency lighting in addition to the required emergency lighting; the supplementary emergency lighting shall be as follows:
  - (a) all passenger public spaces and alleyways shall be provided with supplementary emergency lighting that can operate for at least three hours when all other sources of electric power have failed and under any condition of heel;
  - (b) the source of power for the supplementary emergency lighting shall consist of accumulator batteries located within the lighting units that are continuously charged, where practicable, from the emergency switchboard; alternate means of lighting that are equally effective may be installed if plans of the lighting and its installation are submitted to the Board for inspection prior to installation; the supplementary emergency lighting shall be such that any failure of the lamp will be immediately apparent;
  - (c) any accumulator battery provided shall be replaced at intervals having regard to the specified service life in the ambient conditions that they are subject to in service,
  - (d) a portable rechargeable battery operated hand lamp shall be provided in every crew space alleyway, recreation space, and every working space which is normally occupied, unless supplementary emergency lighting, as required by 1.13 (a) and (b) is provided.

## 2. DESIGN OF EQUIPMENT

- 2.1 For the purpose of these Standards, the following cooling air and cooling water temperatures are applicable:
- (a) for ships making foreign and home trade Class I voyages and ships that operate within the tropical belt:
    - (i) a primary cooling water supply temperature of 30°C; and
    - (ii) a cooling air temperature of 45°C except for electrical machines located in machinery spaces in which case the cooling air temperature is 50°C; and
  - (b) for ships other than those described in paragraph (a):
    - (i) a primary cooling water supply temperature of 25°C; and
    - (ii) a cooling air temperature of 40°C.
- 2.2 All electrical apparatus shall be constructed so as to function satisfactorily during voltage fluctuations within 10% below and 6% above the nominal voltage of the system.
- 2.3 Alternating current apparatus shall be constructed so as to function satisfactorily at frequencies within 5% of the nominal frequency of the system.
- 2.4 All electrical conductors, switchgear and accessories shall be of such size as to be capable of carrying, without their respective ratings being exceeded, the maximum current that can normally flow through them.
- 2.5 All electrical equipment shall operate satisfactorily under all conditions with the ship at the following inclination from the normal; transversely: 15° - rolling: up to 22°30' and longitudinally: 7°30' for all ships; emergency installations shall in addition operate satisfactorily when the ship is inclined 22°30' and/or when the trim of the ship is 10°.
- 2.6 A substantial addition shall not be made to the authorized load of an existing installation until an inspection under Section 36.2 indicates that the current-carrying capacity and the condition of the existing accessories, conductors, switchgear and all other equipment affected are adequate for the increased load.
- 2.7 Electrical equipment which includes, appliances, accessories and fittings shall bear the classification mark of the Canadian Standards Association (CSA); or where special marine type equipment is required and there is no standard for it, it shall be of a type that is safe and effectively fulfils the purpose for which it was intended.
- 2.8 **Notwithstanding subsection 2.7 electrical equipment manufactured outside Canada shall be constructed to meet the most recent version of an applicable rule or code issued by a Society, Association or a recognized Classification Society and shall bear the identification mark of the testing laboratory or certifying authority that verifies that the equipment meets the rule or code.**
- 2.9 Solid insulating materials purporting to be non-combustible and flame-retardant shall conform to the test requirements specified in the C.S.A. Guide for the Preparation of Test Procedures for the Thermal Evaluation of Insulation Systems for Electrical Equipment.
- 2.10 In general, all electrical equipment shall be constructed of durable, flame-retardant, non-hygroscopic materials which are not subject to deterioration in the atmosphere and temperatures to which they are likely to be exposed; where hygroscopic materials are used in contact with live parts, secondary non-hygroscopic insulation shall be incorporated.
- 2.11 Insulating materials and insulated windings shall be resistant to moisture, sea air and oil vapours unless special precautions are taken to protect them from their deleterious effects; porcelain, if used, shall not be rigidly fastened by machine screws or the equivalent, and shall not be exposed to direct mechanical damage.

- 2.12 The distances between live parts of different potential and between live parts and the enclosure or other grounded metal, whether across surfaces or in air shall be adequate for the working voltage having regard to the nature of the insulating material and conditions of service.
- 2.13 Any grounded metal or parts of the enclosure in proximity to the arc from contactors, circuit breakers or other contacts liable to arc, or in proximity to semi-enclosed fuses, shall be lined with arc-resisting insulating material.
- 2.14 The design of the electrical equipment shall provide accessibility to all parts requiring inspection and maintenance.
- 2.15 Apparatus shall be provided with suitable cable or conduit entries; enclosures of drip-proof apparatus shall not have cable entries on the top unless the cable entry plate and cable attachment is so made to exclude water.
- 2.16 Conductors shall be supported so that no injurious strain is imposed on the terminals of any electrical apparatus or devices or any joints or taps.
- 2.17 Terminal or connection boxes shall be of sufficient size to accommodate wiring without crowding and each box shall be of adequate mechanical strength and rigidity to protect the contents and to prevent distortion under all normal conditions of service; cables of differing voltage shall not be included in the same junction or terminal box unless each voltage is clearly and permanently identified and effective barriers provided within the enclosure to separate each voltage; terminal connections for incoming cables shall be physically separated from internal connections.
- 2.18 Machines and apparatus shall be so constructed that their efficiency is not impaired by vibration and shock likely to arise under normal service conditions; screws and nuts securing current carrying parts shall be of a type or provided with a device to prevent them from working loose due to vibration.
- 2.29 Accessories shall be so designed and constructed that the passages for insulated conductors are of ample size and are free from rough projections, sharp angles and abrupt bends and all outlets for cables shall have well rounded edges or be suitably bushed.
- 2.20 Accessories shall be so designed and fixed that dust and moisture cannot readily accumulate on the insulation or on live parts.
- 2.21 Electric radiators shall be constructed to reduce fire risks to a minimum and their heating elements shall not be so exposed that clothing, curtains or other materials can be scorched or set on fire by heat from the element.
- 2.22 A non-conducting mat or a grating of impregnated wood shall be provided in front of switchgear and control gear assemblies and also at the rear and sides if access is necessary for operation or maintenance. Where assemblies are of the walk-mats or gratings shall also be provided on the inside.

### 3. INSTALLATIONS, LOCATION AND PROTECTION OF ELECTRICAL EQUIPMENT

- 3.1 Electrical apparatus shall be so constructed and installed that danger of injury in ordinary handling shall not exist.
- 3.2 The installation of electrical equipment shall avoid all hazardous locations where explosive dusts, flammable gases or vapors are liable to accumulate unless it is essential for safety or the operational procedures of the vessel. Where electrical equipment is necessary to be located in a hazardous location it shall be of a type certified safe for operation in the particular atmosphere or location as noted in Section 26.
- 3.3 In hazardous areas where explosion-proof equipment is installed, the integrity of the equipment shall be maintained by the use of suitable explosion-proof rated seals or connectors.
- 3.4 Switchgear and control and instrumentation equipment shall be mounted in suitable fire resisting enclosures, so located as to be readily accessible for operation and maintenance.
- 3.5 Electrical equipment shall be so placed that, as far as practicable, it is not exposed to risk of mechanical damage.
- 3.6 Electrical equipment shall be suitable for the usual general conditions of shipboard marine service and shall be located as far as practicable clear of boilers, steam pipes, fuel tank openings and machinery exhaust pipes or manifolds and shall be protected from dripping water, oil, etc. where necessary when the equipment is inclined at any angle up to 15° from the vertical.
- 3.7 Electrical equipment used for essential services and located in areas where sprinkler heads or spraying devices for fire prevention are fitted, shall be of an integrity such that water cannot cause malfunction of the equipment.
- 3.8 Emergency electrical machines and equipment shall not be installed forward of the collision bulkhead.
- 3.9 Every horizontal rotating machine shall, where practicable, be installed in the fore and aft direction; where a machine has to be installed athwartships, the design of the bearings and the arrangements for lubrication shall be suitable for withstanding the stresses encountered in heavy weather.
- 3.10 Electrical apparatus shall be so installed that sufficient space is available for maintenance.
- 3.11 Open type machinery and control gear shall be provided with suitable guards to obviate risk of injury to persons.
- 3.12 When installing electrical equipment, consideration shall be given to the deleterious effects of galvanic action due to dissimilar metals in contact.
- 3.13 Switchboards shall be installed so that no pipes or tanks carrying or containing liquids are above them within the same space; where this is unavoidable, pipes shall be without joints in such positions; switchboards which are located immediately above or adjacent to open bilge areas or tank tops shall be enclosed at the bottom.
- 3.14 Accessories shall be so designed and insulated conductors shall be so installed that stress cannot be applied by the conductors to any terminal to which they may be connected.
- 3.15 Accessories shall be so designed and fixed that dust and moisture cannot readily accumulate on the insulation or on live parts.
- 3.16 Where basically different distribution systems are in use, the receptacles and plugs shall be so designed that incorrect connection cannot be made.
- 3.17 Receptacles shall not be fitted in bathrooms or washrooms unless an a.c. supply is used and the receptacles are each fitted with an isolating transformer; receptacles fitted in bathrooms and washrooms shall be used for electric razors only; on effectively grounded distribution systems ground fault interrupting receptacles may be used in lieu of isolation transformers.

- 3.18 On weatherdecks, in stokeholds and engine rooms and wherever they are exposed to drip or condensed moisture, receptacles and plugs shall be weatherproof and provided with means for maintaining this quality after removing the plug.
- 3.19 In galleys, laundries, bathrooms and similar locations, in areas, which are moisture laden, switches shall be of watertight construction or shall be enclosed in insulation which is durable and substantially continuous.
- 3.20 Electrical radiators shall be fixed in position.
- 3.21 In special category spaces above and below the bulkhead deck the equipment and installation shall be in accordance with Section 26.21 (a) and (b) respectively:
- 3.22 Closed Ro-Ro spaces in cargo vessels containing motor vehicles with fuel in their tanks for their own propulsion shall be in accordance with Section 26.22
- 3.23 The design of devices employed for dimming indicating and instrument lighting located on the navigating bridge shall not permit the total extinguishment of the lamps.

## 4. GROUNDING OF NON-CURRENT-CARRYING PARTS

- 4.1 All accessible metal parts of an electrical installation, other than current-carrying parts, shall be grounded.
- 4.2 Subsection (1) does not apply to:
- (a) lamp bases;
  - (b) shades, reflectors or guards supported on lamp holders or lighting fittings constructed of or shrouded in non-conducting material,
  - (c) portable appliances having double or reinforced insulation;
  - (d) portable appliances that are protected by isolating transformers;
  - (e) bearing housings that are insulated in order to prevent the circulation of current in the bearings,
  - (f) apparatus supplied at not more than 55 volts; and
  - (g) cable clips;
  - (h) the metal core of the isolating transformer in accordance with Section 11.39 (e) (i) and Figure 11-1.
- 4.3 The grounding of non-current-carrying parts of electrical equipment shall be effected by the following methods:
- (a) metal frames or enclosures of apparatus shall be fixed to, and be in metallic contact with the ship's structure, provided that the surfaces in contact are clean and free from rust, scale or paint when installed and are firmly bolted together; alternatively, they shall be connected to the hull, either direct or via the grounding terminal of a receptacle outlet; metallic cable sheath shall not be solely relied upon for this purpose;
  - (b) the metal sheaths and armour of cables shall be grounded by means of glands or connectors intended for the purpose and so designed as to ensure an effective ground connection; the gland shall be firmly attached to, and be effective electrical contact with a metal structure grounded in accordance with these Standards;
  - (c) conduits shall be grounded by being screwed into a metal enclosure, or by nuts on both sides of the wall of a metal enclosure provided the surfaces in contact are clean and free from rust, scale or paint and that the enclosure is grounded in accordance with these Standards;
  - (d) as an alternative to the methods described in paragraphs (b) and (c), cable sheaths, armours and conduit shall be grounded by means of clamps or clips of corrosion-resistant metal, making effective contact with the sheath or armour and grounded metal; and
  - (e) all joints in metal conduits and ducts and in metal sheaths of cables, which are used for ground continuity, shall be soundly made and protected where necessary against corrosion.
- 4.4 Every grounding conductor shall:
- (a) be of copper or other corrosion-resistant material,
  - (b) be securely installed and protected where necessary against mechanical damage,
  - (c) where necessary protected against electrolytic corrosion: and,
  - (d) be at least as large as the supply cable to the equipment for cables up to 16 mm<sup>2</sup> (6 awg), above 16 mm<sup>2</sup> (6 awg) at least one half the size of the supply cable but not less than 16 mm<sup>2</sup> (6 awg);
  - (e) the conductor shall be a bare copper conductor or if coloured shall be in accordance with Section 12.13.

- 4.5 On wood and composite ships, a continuous ground conductor shall be installed to facilitate the grounding of non-conducting exposed metal parts; the ground conductor shall terminate at a copper plate area not less than 0.2 m<sup>2</sup> fixed to the keel below the light waterline so as to be fully immersed under all conditions of heel; the minimum size of the ground conductor shall be not less than 16 mm<sup>2</sup> (#6 AWG).
- 4.6 Every ground connection to the ship's structure or on wood and composite ships to the continuous ground conductor, shall be made in an accessible position and shall be secured by a screw or connector of brass or other corrosion-resistant material used solely for that purpose.
- 4.7 Metal frames of all portable electric lamps, tools and similar apparatus rated in excess of 50 volts shall be grounded through a suitable conductor unless equivalent safety provisions are made such as by double insulation or by an isolating transformer.

## 5. APPLICATION OF DEMAND LOADS

- 5.1 Generator, bus tie and feeder cables shall be selected on the basis of:
- (a) a computed load of not less than the demand load specified in Table 5-1; and
  - (b) the drop in voltage from the switchboard busbars to every point on the installation when the conductors are carrying the maximum service, not exceeding:
    - (i) for lighting circuits, 6% of the nominal voltage; and
    - (ii) for heating and power circuits, 7% of the nominal voltage.
- 5.2 In the assessment of demand loads for motive-power circuits, the normal full load shall be based on the nameplate rating of motors, and for ac circuits, account shall be taken of the relatively small decrease in current consumption of partially loaded motors.

**TABLE 5-1**

Generator Main Cables	a) <b>not less</b> than 100% of the continuous full-load rating for continuous rated machinery, or not less than the overload b) <b>not less</b> than the overload rating for machines having a two hour overload rating or other specially rated machines
Emergency Switchboard Bus-Tie Feeder	125% Emergency generator full-load rating or emergency switchboard maximum operating load whichever is greater.
Feeders Supplying Two Or More Motors	125% of the rating of the largest motor plus 100% of the sum of the nameplate ratings of all other motors which can be in operation simultaneously plus 50% of the rating of spare circuits.
Feeders Supplying Two or More Cargo Winch Motors, Cargo Elevator Motors, or Cargo Cranes	125% of the rating of largest motor plus 50% of the sum of the ratings of all other motors supplied.
Galley Equipment	100% of the first 50kW or one half of the connected load, whichever is larger, plus 65% of the remaining connected load, plus 50% of spare circuits
Lighting Branch Circuits	100% of the connected load. Single and duplex convenience receptacles are to be estimated at 75 watts each.
Lighting Feeders	100% of the connected load plus spare allowance. Each spare circuit to be estimated as equivalent to the average load of the active circuits of corresponding rating. The branch feeder circuits for the navigation light panel shall be in accordance with Section 11.37(f).



## 6. DIRECT CURRENT SERVICE SYSTEMS FOR SHIPS OTHER THAN TANKERS

- 6.1 The following distribution systems are considered standard for dc generation on ships other than tankers:
- (a) 2-wire insulated; and
  - (b) 3-wire with neutral wire grounded, but without hull return.
- 6.2 The voltage of supply shall not normally exceed the maximum values given in Table 6-1.

**TABLE 6-1**

**DC Supply Voltages**

<b>APPLICATION</b>	<b>MAXIMUM VOLTAGE</b>
Power	1000
Cooking and Heating	250
Lighting and Receptacle Outlets	250
Internal Communications	250

**7. ALTERNATING CURRENT SERVICE SYSTEMS**

- 7.1 The following distribution systems are considered standard for ac generation on ships: (for tankers Refer to Section 26.4 and 26.17)
- (a) 3-phase, 3-wire insulated;
  - (b) 3-phase, 4-wire with neutral grounded solidly at one point at the main switchboard but without hull-return;
  - (c) single-phase, 2-wire insulated or one side grounded without hull-return; and
  - (d) single-phase, 3-wire without hull-return and neutral grounded solidly at the main switchboard.
- 7.2 The following frequencies are recognized as standard:
- (a) 60 hertz; and
  - (b) 50 hertz.
- 7.3 The voltage of supply shall normally not exceed the maximum values given in Table 7-1.

**TABLE 7-1****AC Supply Voltages**

APPLICATION	MAXIMUM VOLTAGE
Power, heating and cooking equipment securely fixed and permanently connected	600
Fixed lighting, heaters and controls which are bulkhead mounted in cabins and public rooms, and other applications not mentioned above *	250
Internal communications	250

\* This does not preclude the use of electric-discharge lighting systems operating at voltages in excess of 250 volts.

- 7.4 Generation and distribution at voltages in excess of 600 volts may be utilized when necessary for systems having large generating capacity and high fault power.
- 7.5 The vital services on all vessels that have a grounded neutral distribution system shall be supplied from an insulated distribution system.
- 7.6 The grounded neutral conductor of a distribution system in accordance with 7.1 (b), (c) or (d) shall be independent of those conductors employed for the grounding of the non-current carrying parts of electrical equipment noted in Section 4; the size of the grounding conductor shall be based on the size of the current carrying supply conductor of the electrical equipment as follows:

If A is the size of the supply cable then:

$$A \leq 3\text{mm} \quad A=A$$

$$A \text{ } 3\text{mm} \leq 120\text{mm} \quad A/2 \text{ the minimum is } 3\text{mm}$$

$$>120\text{mm} \quad A/2$$

## 8. SYSTEM PROTECTION – GENERAL

- 8.1 Throughout the installation every circuit breaker and fuse shall be suitable for operation at the maximum short-circuit current which can pass through it, except that a circuit breaker or fuse of a breaking capacity less than the prospective short-circuit current at the point of application where it is installed may be used, provided that it is backed up by:
- (a) a calibrated fuse of suitable category of duty; or
  - (b) a circuit breaker with an instantaneous trip setting of not more than 90% of the breaking capacity of the device protected and the back-up protective device shall have a breaking capacity not less than the prospective short-circuit current at the point where it is installed and the time-current characteristics shall be suitably co-ordinated.
- 8.2 The making capacity of every circuit-breaker or switch intended to be capable of being closed, if necessary, on short-circuit, is to be not less than the maximum value of the short-circuit current at the point of installation; on alternating current this maximum value corresponds to the peak value allowing for maximum asymmetry.
- 8.3 Overload and short-circuit protection shall be so arranged that effective discrimination is achieved for all essential services.
- 8.4 For the evaluation of the prospective short-circuit current in ac systems, the equivalent system impedance shall be considered, seen from the point of fault.
- 8.5 The maximum asymmetrical rms short-circuit current shall be assumed to be equal to the sum of the generator contribution based on circuit impedances including direct axis sub-transient reactances of generators, and the motor contribution based on 4 times the rated current of motors.
- 8.6 The average asymmetrical rms short-circuit current shall be assumed to be equal to the sum of the generator contribution based on circuit impedances including the direct axis sub-transient reactances of generators and the motor contribution based on 3.5 times the rated current of motors.
- 8.7 For ac systems, the maximum available short-circuit current shall be determined from the aggregate contribution of all generators that can be simultaneously operated in parallel and the maximum number of motors which will be in operation simultaneously with a three-phase fault on the load terminals of the protective device; under these conditions, three-pole breakers shall be selected on the basis of the average asymmetrical rms value of the currents in the three phases; fuses shall be selected on the basis of the maximum asymmetrical rms value of the current occurring in any one of the three phases; the asymmetrical rms values of current can be obtained by applying the K1 and K2 factors of Figure 8-1 to the symmetrical values or by using the values of Table 8-1; the X/R ratio of Figure 8-1 is determined from the inductive reactance (X) and the resistance (R) of the circuit under consideration; for a preliminary estimate of short-circuit currents, pending the availability of generator reactances, the following may be used for estimating the generator contribution:
- (a) maximum asymmetrical rms current, 10 times generator full load current;
  - (b) average asymmetrical rms current, 8.5 times generator full load current; and
  - (c) these values for estimating generator contribution shall not be used where unusually stringent transient voltage dip limitations have been specified for the generator.
- 8.8 For the evaluation of the maximum short-circuit current on dc systems, it shall be assumed that each generator which can be simultaneously operated in parallel will, if limited only by internal resistance, contribute ten times the normal rated current and that all motors which may be in operation simultaneously will contribute six times their combined normal ratings.
- 8.9 Where provision is made to obtain an external supply from on-shore or elsewhere, the interrupting capacity of the shore connection protective device shall be based on the maximum short-circuit current available from the external source.

- 8.10 Fuses shall be so applied that single-phase operation of any three-phase connected ac motor will be precluded; where overload protection is not designed to provide single-phase protection additional means of single-phase protection is required.

**TABLE 8-1****ASYMMETRICAL FACTORS**

Short Circuit X/R Ratio	RATIO TO SYMMETRICAL RMS AMPERES	
	Maximum 1-phase Rms Amperes at ½ Cycle $M_m$  (Asymmetrical Factor) K2	Average 3-phase Rms Amperes at ½ Cycle $M_a$  K1
-	1.732	1.394
100.00	1.696	1.374
49.993	1.665	1.335
33.322	1.630	1.336
24.979	1.598	1.318
19.974	1.568	1.301
16.623	1.540	1.285
14.251	1.511	1.270
13.460	1.485	1.256
11.066	1.460	1.241
9.9301	1.436	1.229
9.0354	1.413	1.216
8.2733	1.391	1.204
7.6271	1.372	1.193
7.0721	1.350	1.182
6.5912	1.330	1.171
6.1695	1.312	1.161
5.7947	1.294	1.152

5.4649	1.277	1.143
5.1672	1.262	1.135
4.8990	1.247	1.127
4.6557	1.232	1.119
4.4341	1.218	1.112
4.2313	1.205	1.105
4.0450	1.192	1.099
3.8730	1.181	1.093
3.7138	1.170	1.087
3.5661	1.159	1.081
3.4286	1.149	1.075
3.3001	1.139	1.070
3.1798	1.130	1.066
3.0669	1.121	1.062
2.9608	1.113	1.057
2.8606	1.105	1.053
2.7660	1.098	1.049
2.6764	1.091	1.046
2.5916	1.084	1.043
2.5109	1.078	1.039
2.4341	1.073	1.036
2.3611	1.068	1.033
2.2913	1.062	1.031
2.2246	1.057	1.028
2.1608	1.053	1.026
2.0996	1.049	1.024
2.0409	1.045	1.022

1.9845	1.041	1.020
1.9303	1.038	1.019
1.8780	1.034	1.017
1.8277	1.031	1.016
1.7791	1.029	1.014
1.7321	1.026	1.013
1.5185	1.015	1.008
1.3333	1.009	1.004
1.1691	1.004	1.002
1.0202	1.002	1.001
0.8819	1.0008	1.0004
0.7500	1.0002	1.00005
0.6198	1.00004	1.00002
0.0000	1.00000	1.00000

**FIGURE 8-1****FAULT CURRENT DECREMENT CONVERSION FACTORS**

X/R ratio

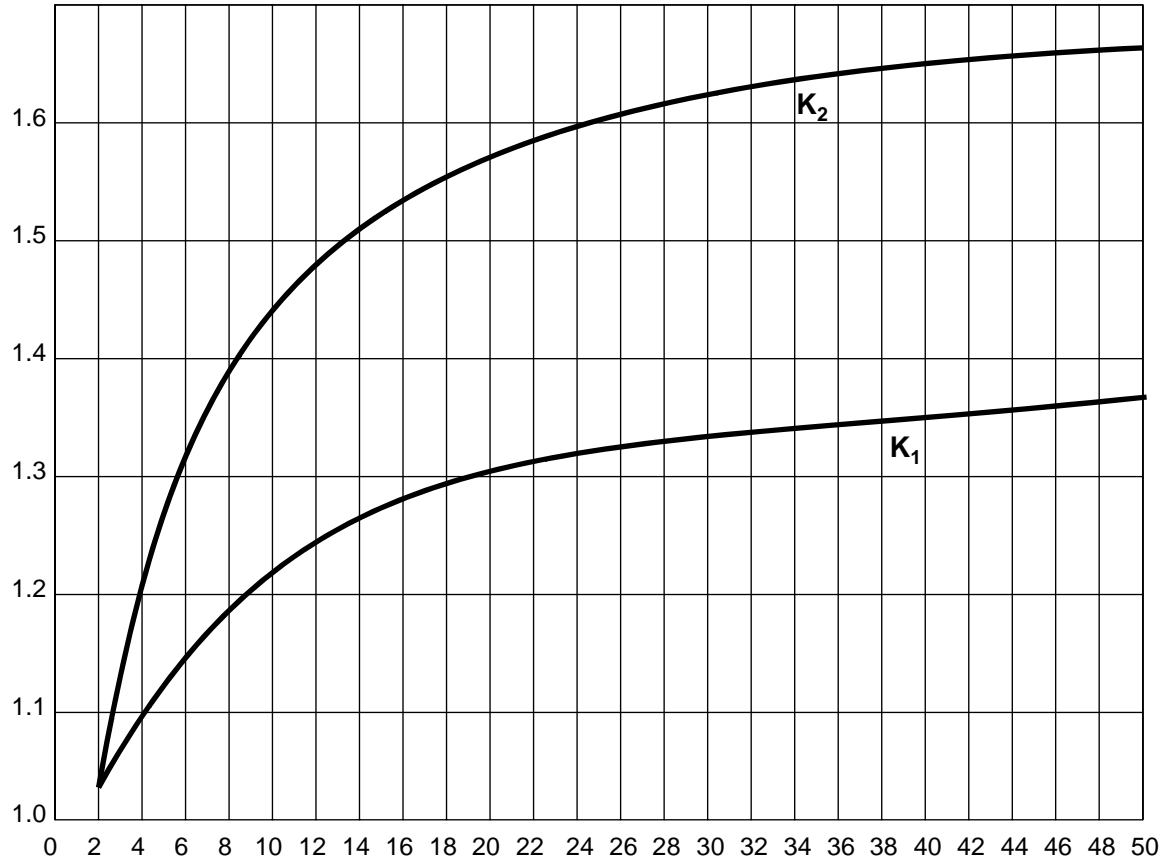

K<sub>1</sub> Ratio of the average asymmetrical rms current in the three phases at one half cycle to the rms value of the symmetrical current.

K<sub>2</sub> Ratio of the maximum rms asymmetrical current in one phase at one-half cycle to the rms value of the symmetrical current.

## 9. SWITCHBOARDS OTHER THAN PROPULSION CONTROL PANELS

### SECTION 9

#### 9.1 GENERAL:

9.1.1 Every ship's service and emergency generator shall be connected to a main or an emergency switchboard.

#### 9.2 INSTALLATION AND LOCATION:

9.2.1 An unobstructed passageway not less than 1 metre wide shall be provided in front of the switchboard; in the case of small ships, if this distance is impracticable, the passageway may be reduced to 0.6 metre.

9.2.2 If access is required at the rear of switchboards, the space shall be sufficient to permit maintenance, and be not less than 0.5 metre clear.

9.2.3 Passageways behind main switchboards shall be of ample height and shall, where practicable, be provided at each end with an access door, fitted with an external lock and such access doors shall bear a prominent and permanent indication of the maximum voltage; in the case of metal clad switchboards that are completely enclosed, access doors need not be fitted;

9.2.4 They shall give easy access from the back, unless designed for installation against bulkheads, and front without danger to personnel;

9.2.5 The sides and backs and, where necessary, the fronts shall be suitably guarded;

9.2.6 A non conducting mat or grating shall be provided as a floor covering at the front and rear, as necessary;

9.2.7 The switchboard shall be installed in a dry location away from sources of steam, water and oil pipes

#### 9.3 CONSTRUCTION:

9.3.1 Main and emergency switchboards shall be arranged as follows:

- (a) for voltages between poles or to ground of 50 volts and over, switchboards shall be of a dead front or metal enclosed type; and
- (b) a separate cubicle is to be provided for each generator with flame retardant partitions between the different generator cubicles and between cubicles for outgoing circuits; flame retardant partitions are also to be provided between generator control cubicles and associated switchgear; switchboards controlling generators with an aggregate capacity less than 100 kW shall have a flame retardant partition between each generator circuit breaker and outgoing distribution circuits.

9.3.2 Every main and emergency switchboard shall be provided with non conducting handrails fitted on the front of the panel.

9.3.3 A non conducting guardrail shall be fitted at the rear of the switchboard if maintenance from the rear is required.

9.3.4 In every ship where the total installed electrical power of the main generator is in excess of 3 megawatts, the main bus bars shall be subdivided into at least two parts which shall normally be connected by means of a circuit breaker or similar device arranged so as to readily disconnect the two parts; so far as is practicable, the connection of generators and any other duplicated equipment shall be equally divided between the parts; equivalent alternative arrangements shall be permitted.

9.3.5 Insulating materials used in the construction of switchboards shall be mechanically strong, flame retardant, moisture resistant and have anti tracking surface finish.



- 9.3.6 Suitable drip shields shall be provided over switchboards where subject to damage by leaks or falling objects.
- 9.3.7 Panels shall be of substantial construction to prevent vibration and hinged panels and doors of dead front switchboards shall be provided with positioners and stops.
- 9.3.8 If drawout generator breakers are not fitted, then disconnect links or an isolating switch shall be fitted.
- 9.3.9 Switchboard instrumentation and control wiring shall be:
- (a) of a type suitable for the service intended with respect to voltage, temperature and grouping;
  - (b) conductors shall not be smaller than # 18 AWG;
  - (c) for wiring of printed circuit boards and interconnecting wiring between electronic modules and subassemblies, the conductor shall not be smaller than # 24 AWG;
  - (d) all conductors shall be capable of passing a vertical flame test in accordance with ANSI/UL 83-1979 (31) or CSA C22.2 No. 127 where applicable and shall be either insulated wire types TA, TBS, TEW, SIS, SEW-2 OR SEWF-2;
  - (e) connections to hinged panels shall be with the extra flexible type and have mechanical protection at the hinges in order to prevent chafing.
- 9.3.10 All circuit breakers shall indicate the “OPEN” off position or the “ON” closed position and in addition where circuit breakers are operated vertically rather than rotationally or horizontally the “UP” position of the operator handle shall be the “ON” position; where the switches are operated horizontally the handles for a single row shall be to the right for the “ON” position or where two rows are required the “ON” position shall be to the center.
- 9.4 DESIGN:
- 9.4.1 BUS:
- Bus size shall be selected on the basis of limiting the bus bar temperature rise to 50°C at rated current; Table 9-1 shall be used in determining the necessary bus bar size; buses shall be designed on the basis of generator capacity and feeder loads; for a single generator, the generator bus shall have a capacity equal to the continuous rating of the generator plus any overload rating in excess of 30 minute duration; for more than one generator with all generating capacity feeding through one section of the bus, the capacity of the bus for the first generator shall be the same as for a single generator installation; for each subsequent generator, the bus capacity shall be increased by 80 percent of the continuous rating of the added generator; the capacity of connection buses for each generator unit shall be equal to the continuous rating of the generator plus any overload rating in excess of 30 minute duration.
- 9.4.1.2 The buses of feeder switchboards shall have a capacity of not less than 75% of the combined full load rated current of all loads including 50% of the rated installed or design reserve spare breaker capacity; the capacity of the feeder buses need not be greater than the generator buses which supply them; bus connections to individual feeder circuit breakers shall be designed on the basis of the frame rating of the breakers when the frame rating is 600 A or less; for frame ratings above 600 A, the bus connections shall not be less than the breaker trip rating.
- 9.4.1.3 Bolts, nuts and pressure maintaining devices used to maintain contact on bus and connection bars shall be of a non ferrous material or of steel rendered corrosion resistant by zinc electroplating or an equivalent process; connection between bus bars with a width of 76 mm or larger shall be made with a multi bolt arrangement.
- 9.4.1.4 The current rating of the equalizer connection and equalizer switches shall be not less than 1/2 the rated full load current of the largest generator.

**TABLE 9-1****Ampere rating of Rectangular Bus Bar Placed on Edge**

(Based on 50°C Ambient and 50°C rise)

NUMBER OF BUS BARS IN PARALLEL	SIZE OF BARS		AMPERE RATING OF D.C. COPPER BARS	AMPERE RATING OF A.C. COPPER BARS
	(INCHES)	MM		
One	3/4 x 1/8	19.1 x 3.2	250	250
	1 x 1/8	25.4 x 3.2	330	330
	1 1/2 x 1/8	38.1 x 3.2	500	500
	1 1/2 x 3/16	38.1 x 4.8	580	570
	2 x 3/16	50.8 x 4.8	760	745
	1 x 1/4	25.4 x 6.4	490	480
	1 1/2 x 1/4	38.1 x 6.4	685	675
	2 x 1/4	50.8 x 6.4	920	900
	3 x 1/4	76.2 x 6.4	1380	1280
	4 x 1/4	101.6 x 6.4	1730	1650
	5 x 1/4	127.0 x 6.4	2125	2000
	6 x 1/4	152.4 x 6.4	2475	2300
	8 x 1/4	203.2 x 6.4	3175	2875
Two (1/4 in. apart 6,4mm)	2 x 1/4	50.8 x 6.4	1525	1450
	3 x 1/4	76.2 x 6.4	2225	2050
	4 x 1/4	101.6 x 6.4	2800	2550
	5 x 1/4	127.0 x 6.4	3100	2975
	6 x 1/4	152.4 x 6.4	4000	3450
	8 x 1/4	203.2 x 6.4	5100	4250
Three (1/4 in. apart 6,4mm )	3 x 1/4	76.2 x 6.4	3035	2550
	4 x 1/4	101.6 x 6.4	3875	3225
	5 x 1/4	127.0 x 6.4	4700	3880
	6 x 1/4	152.4 x 6.4	5500	4400
	8 x 1/4	203.2 x 6.4	6875	5300
Four ( 1/4, 2 1/2, 1/4 apart) 6.4mm, 63.5, 6.4	3 x 1/4	76.2 x 6.4	3300	3050
	4 x 1/4	101.6 x 6.4	4500	4250
	5 x 1/4	127.0 x 6.4	5425	5000
	6 x 1/4	152.4 x 6.4	6300	6000
	8 x 1/4	203.2 x 6.4	7200	7100

- 9.4.1.5 Switchboard bus bars and supports shall be of substantial and durable construction and shall be capable of withstanding electromechanical stresses which may arise from short circuit faults.
- 9.4.1.6 Bus bars and their connections shall be of copper, all connections being tinned or silver surfaced so as to inhibit corrosion and reduce contact resistance.
- 9.4.1.7 Bus bars, connection bars and wiring on the switchboard shall be arranged so that maximum accessibility is provided for cable connections.
- 9.4.1.8 Bare main bus bars in main and emergency switchboards shall have minimum clearances and creepage distances in accordance with the Table 9-2:

**TABLE 9-2**

MAXIMUM RATED VOLTAGE BETWEEN PHASES AND POLES	MINIMUM AIR CLEARANCE TO GROUND	MINIMUM AIR CLEARANCE BETWEEN PHASES AND POLES
125	12.5 mm	12.5 mm
250	12.5 mm	19.0 mm
500	22.0 mm	22.0 mm
600	22.0 mm	25.5 mm

#### 9.4.2 INSTRUMENTS, INDICATION and PROTECTIVE DEVICES

- 9.4.2.1 All switchboard instruments, control circuit fuses, and all apparatus controlling circuits shall be provided with nameplates of durable flame retardant material bearing clear and indelible indication, including fuse rating.
- 9.4.2.2 All electrical indicating instruments other than synchrosopes shall preferably be of the 250° nominal scale type.
- 9.4.2.3 The upper limit of the scale of every ammeter and wattmeter shall be not less than 130% of the normal rating of the circuit in which it is installed and the scale shall be provided with a red line indicating the normal full load value.
- 9.4.2.4 The upper limit of every voltmeter shall be not less than 120% of the normal voltage of the circuit and the scale shall be provided with a red line to indicate normal voltage; examples of common system voltages and their corresponding voltmeter scales are given in the Table 9-3

**TABLE 9-3**

RANGE OF SYSTEM VOLTAGE	VOLTMETER SCALE
115 - 220	0 - 150
220 - 240	0 - 300
440 - 480	0 - 600
550 - 600	0 - 750
2400	0 - 3000
4160	0 - 5250

- 9.4.2.5 Wattmeters for use with generators which may operate in parallel shall be capable of indicating reverse power up to 15% of the rated full load of the generator.
- 9.4.2.6 Means to continuously indicate the state of the insulation to ground shall be provided for primary and secondary distribution systems; on an insulated system ground indicating lights may be used; one light to be fitted in each phase or pole; on systems with a grounded neutral an ammeter and ammeter switch shall be provided which will indicate current in the 0 to 10 ampere range; the ammeter switch shall be of the type that has a spring return to "ON" position; the ammeter and current transformer shall be of a design that they are not damaged by fault currents; where the ammeter is located in a remote enclosure from the current transformer, a suitable protective device shall be provided to prevent high voltage in the event of an open circuit; a short circuiting switch shall be connected in parallel with the protective device for manually short circuiting the remote part of the current transformer.
- 9.4.2.7 Where a ground indicating system using either two or three lamps is adopted, the lamps shall be of the metal filament type each not exceeding 30 watts; systems employing a single lamp shall not be used.
- 9.4.2.8 Secondary windings of all instrument and control transformers shall be effectively grounded.
- 9.4.2.9 Fuses of ratings exceeding 320 amperes shall not be used, other than for short circuit protection.
- 9.4.2.10 Subject to subsection (4.2.11), over current protection, independent of that provided for other circuits, shall be provided for circuits containing voltmeters, voltage coils of instruments, primary circuits of voltage transformers, ground indicating lights and pilot lamps and the fuses used for this purpose shall be of adequate breaking capacity and shall be placed as near as practicable to the tapping of the supply.
- 9.4.2.11 Over current protection for circuits containing ground indicating lights and pilot lamps shall not also be used for circuits containing voltmeters or voltage coils of instruments and protective devices except when the lamp is an integral part of the instrument.
- 9.4.2.12 Automatic voltage regulators shall be supplied separately from all other instrument circuits and short circuit protection only shall be provided for the voltage coils by fuses of adequate breaking capacity located as near as practicable to the source of supply.
- 9.4.2.13 The settings of "preference tripping" relays shall be adjustable.
- 9.4.2.14 Circuit breakers for turbine driven generators shall open automatically when the emergency overspeed switch operates.
- 9.4.2.15 Fuses protecting trip device circuits shall not also be used to protect any other circuit.
- 9.4.2.16 Excluding ground fault detection systems, voltage (potential) and current transformers shall be used for all instruments, meters, relays, control switches and other devices, which operating personnel may be in contact with so that the maximum operating voltage of the devices will not exceed 250 volts.
- 9.4.2.17 Current transformers used for protective devices shall not be used for any other purpose.
- 9.4.2.18 Nameplates for feeders and branch circuits shall include the circuit designation and the size of the fuses or circuit breaker trip calibration required for the circuit.

- 9.4.2.19 A voltmeter and voltmeter switch shall be provided for reading each phase voltage of the shore connection; a generator voltmeter and switch provided with suitable arrangements may be used for reading each phase voltage of the shore connection.
- 9.4.2.20 Where ac generators are intended for parallel operation there shall be a means provided to protect against the effects of incorrect synchronization during the paralleling process with a means provided manually to override the the device under certain operating conditions.

## 9.5 WITCHBOARD EQUIPMENT:

### 9.5.1 A. C. INSTALLATIONS

- 9.5.1.1 For ac generators not operated in parallel, each generator shall be provided with a frequency meter, a voltmeter and an ammeter in each phase conductor or one ammeter and one voltmeter with a selector switch for each meter designed to read the current and voltage respectively in each phase; a wattmeter shall be provided for each generator rated 50 kW and above; the following switchgear shall be provided:
- (a) for a three phase, three wire insulated or a three phase, four wire grounded neutral system, a three pole switch and fuse arrangement or a three pole moulded case circuit breaker for generators under 25 kW; for generators 25 kW and above circuit breakers are to be provided in accordance with Section 10;
  - (b) for a single phase, two wire insulated or a single phase three wire grounded neutral system, a two pole switch and fuse arrangement or a circuit breaker as described in (a).
- 9.5.1.2 For ac generators operated in parallel, each generator shall be provided with a wattmeter, an ammeter with a selector switch designed to read the current in each phase and a voltmeter with a selector switch to connect the voltmeter to each phase of the generator and to one phase of the bus; suitable means shall be provided to enable one voltmeter to read shore voltage; for paralleling purposes, at least two frequency meters and a synchronizing device comprising a synchroscope and synchronizing lights shall be fitted; means for control of generator prime mover speed shall be provided at the switchboard.
- 9.5.1.3 For ac generators operated in parallel, suitable means shall be provided to enable one frequency meter to be connected to one phase of any one generator before the machine is connected to the bus bars and the other frequency meter shall be permanently connected to one phase of the bus bars.
- 9.5.1.4 Where ac generators are intended for operation in parallel, reverse power relays shall be provided with time lag to prevent the tripping of circuit breakers during switching operations; the reverse power relays shall be suitable for the circumstances of reverse power between the limits of 2% and 15% of full load that may be expected according to the nature of the prime mover.
- 9.5.1.5 Where ac generators are installed, there shall be provided for each generator of 25 kW or over, a circuit breaker which will open simultaneously all insulated poles.

### 9.5.2 D.C. INSTALLATIONS

- 9.5.2.1 For dc generators not operated in parallel, one voltmeter and one ammeter shall be provided for each generator.
- 9.5.2.2 For parallel operation at least one ammeter shall be provided for each dc generator and one voltmeter, together with selector switch for measuring each generator voltage and the bus bar voltage.

- 9.5.2.3 For each dc generator installed that is not arranged to run in parallel, the following switchgear shall be provided, except that fuses shall be limited as specified in subsection 4.2.9:
- (a) for a 2 wire insulated system either a double pole circuit breaker with over current protection in each pole, or a double pole linked switch and a fuse in each pole;
  - (b) for a 3 wire grounded system, a double pole circuit breaker, connected to the outers, and a link connected to the neutral; and
  - (c) for a 2 wire grounded system, a single pole circuit breaker or a fuse and single pole switch on the ungrounded pole.
- 9.5.2.4 For dc generators that are arranged to run in parallel, the following switchgear shall be provided:
- (a) for a 2 wire insulated system, a double pole circuit breaker with over current protection in each pole and reverse current protection;
  - (b) for 2 wire compound wound generators, an equalizer switch so interlocked with each circuit breaker that it must be closed before the circuit breaker and cannot be opened until the main circuit is opened;
  - (c) for a 2 wire system, the reverse current protection shall be connected on the positive pole;
  - (d) for a 3 wire system with the neutral wire grounded:
    - (i) for a 3 wire shunt wound generator, a triple pole circuit breaker with reverse current protection, or
    - (i) for a 3 wire shunt wound generator, a triple pole circuit breaker with reverse current protection, or
    - (ii) for a 3 wire compound wound generator
      - (A) a five pole circuit breaker with algebraic overload protection embracing each outer and equalizer connection and algebraic reverse current protection, or
      - (B) a three pole circuit breaker interlocked with a five pole linked switch;
  - (e) where reverse current protection is provided, the device shall be suitable for circumstances of reverse current between the limits of 2% and 15% of full load that may be expected according to the nature of the prime mover; and
  - (f) a fall of 50% in the applied voltage shall not render the reverse current mechanism inoperative, although it may alter the amount of reverse current required to open the circuit breaker.

## 10. SWITCHGEAR AND FUSEGEAR

- 10.1 Generator power circuit breakers shall be equipped with adjustable inverse time over-current and instantaneous trip units; the inverse time over-current trip units shall be capable of being set to trip the circuit breaker at 150% generator full-load in 20-30 seconds; other proposed trip settings may be considered provided it is proven that the generator time/current characteristic is such that the over-current can be sustained for the delayed period without impairing the life or effectiveness of the generator insulation or the generator main feeder cables; the pickup setting of the long time over-current trip shall not exceed 115 percent of the generator rating for continuous rated machines and shall not exceed 15% above the overload rating for special rated machines; instantaneous trips shall be set at the lowest value of time and current which will co-ordinate with the trip settings of other system protective devices and shall function at the generator sustained short-circuit current; short-time delays may be incorporated in instantaneous trips for discrimination purposes; where two or more generators are operated in parallel the generator air circuit breakers shall be equipped with undervoltage protection.
- 10.2 Subject to subsection (1), generators rated below 25 kW (not arranged for parallel operation may be protected by molded case circuit breakers having non-adjustable long time over-current trip units. Generators rated between 25 kW and 50 kW may be protected by molded case circuit breakers used in conjunction with long time over-current protection devices. Generators rated between 50 kW and 250 kW may be protected by the use of molded case circuit breakers provided each such circuit breaker is equipped with long time delay over-current protection that has inverse time characteristics. The pickup setting of the long time over-current trip shall not exceed 115 percent of the generator rating for continuous rated machines and shall not exceed 15% above the overload for special rated machines; the setting of the long time delay overcurrent protection should offer maximum protection for the generator, while maintaining selective tripping co-ordination with the distribution system; where the value of generator fault current is such that the instantaneous magnetic trip in the molded case breaker cannot be set at a point low enough to detect the minimum value of fault current available, suitably rated fuses shall be provided in series with the breaker and, in addition, single-phase protection shall be incorporated; generator molded case circuit breakers shall be equipped with undervoltage protection where generators are operated in parallel; the use of molded case circuit breakers for generators intended for parallel operation shall be provided with a device or be designed to ensure the circuit breaker closes in the time necessary to achieve synchronization.;
- 10.3 The rating or setting of over-current devices shall not exceed the current carrying capacity of the conductors which they protect, as specified in Section 12.9 and 12.16, except:
- (a) where the starting current for a motor considerably exceeds the full-load current, such protection shall be designed to allow the excess current to pass during the normal accelerating period of the motor,
  - (b) motor-running over-current protection may be shunted or cut out of the circuit during the starting period of a motor, provided the device by which the over-current protection is shunted or cut-out is not left in the starting position and the motor shall be considered as protected against overcurrent during the starting period if fuses or time-delay circuit breakers are so located in the circuit as to be operative during the starting period of the motor; and
  - (c) short-circuit protection and an overload alarm shall be provided for each steering gear circuit:
    - (i) for dc motors, the feeder circuit breaker shall be set to trip instantaneously at not less than 300% and not more than 375% of the rated full-load current of the steering gear motor, except that the feeder circuit breaker on the emergency switchboard may be set to trip at not less than 200%;
    - (ii) for ac motors, the instantaneous trip setting of the feeder circuit breaker shall be 200% of the steady state locked-rotor current of one steering gear motor plus all other steering gear related loads that may be on this feeder.

- 10.4 Circuit breakers, contactors and switches in outgoing circuits shall be so installed that, as far as practicable, their moving parts and associated relays are not live when in the “off” position so that inspection, adjustment and replacement of parts is facilitated.
- 10.5 Every fuse shall be of the non-renewable type and provided with a suitable non-combustible insulating fuse carrier of such form as to protect a person handling it from shock and burns; effectual provision shall be made for retaining in position all fuses subject to vibration or shock and mechanical damage.
- 10.6 Bus material shall be of copper.
- 10.7 A separate power source shall not be used for the direct control of circuit breakers. (i.e. opening, closing and tripping).



## 11. DISTRIBUTION

- 11.1 In passenger ships, distribution systems shall be so arranged that fire in any main fire zone will not interfere with essential services in any other main fire zone.
- 11.2 The requirement of subsection 11.1 is met if the main and emergency feeders passing through any zone are separated both vertically and horizontally as widely as is practicable.
- 11.3 If, in any passenger ship, two or more generating sets can be in operation at the same time for maintaining the auxiliary services essential for the propulsion or safety of the ship:
- (a) provision shall be made for the sets to operate in parallel; and
  - (b) means shall be provided so that in the event of overload or a partial failure of the supply, the services not essential to the propulsion and safety of the ship will be cut out first, the services essential for those purposes being retained in circuit with such of the generators as may remain in service.
- 11.4 Distribution systems employing a single wire with hull return shall not be used for power, heating or lighting; this does not preclude the use of impressed current cathodic protective systems, limited and locally grounded systems, or insulation level monitoring devices where the circulating current is less than 30 mA.
- 11.5 Every current-consuming appliance shall be connected to either:
- (a) a main switchboard;
  - (b) an emergency switchboard;
  - (c) a distribution centre; or
  - (d) a panelboard;
- 11.6 Each branch circuit shall be protected against short-circuit and, subject to subsection 11.10, shall also be protected against overload.
- 11.7 Each branch circuit operating at voltages of 55 volts or over shall be provided with a switch or circuit breaker with a pole for each conductor; any switch or circuit breaker fitted shall operate simultaneously in the grounded conductor and the insulated conductor.
- 11.8 No fuse, non-linked switch or non-linked circuit breaker shall be inserted in a grounded conductor.
- 11.9 Each circuit shall be permanently indicated together with the rating or setting of the appropriate overload protective device.
- 11.10 Where the steering gear is operated by two independent electrically powered mechanisms and an approved alternative means of steering is not provided, two independent sets of supply cables shall be provided which shall be:
- (a) connected to the main switchboard, except that where there is an emergency generator, one set shall be connected to the main switchboard via the emergency switchboard, in accordance with the requirements of the Marine Machinery Regulations Schedule (VII),
  - (b) Separated throughout their length as widely as practicable,
  - (c) Together with the motors, protected by fuses, circuit breakers or other similar devices against short-circuit; no other overload device or fuse that will open the steering motor power circuit is to be provided in the motor control circuit and the steering control circuits to the bridge; and
  - (d) Short circuit protection only shall be provided for the control circuits of the bridge steering control systems; the protection shall be instantaneous and rated at 300 percent of the current carrying capacity of the smallest control system conductor.
- 11.11 Each steering gear motor starter shall be equipped with a thermal overcurrent relay that shall operate an alarm when the motor is overloaded.

- 11.12 Each steering gear motor is to be provided with the following monitoring devices at the main machinery control position and at the steering control station on the bridge:
- (a) running and stop indication for each steering gear motor;
  - (b) audible alarm and visual lamp indication for the following:
    - (i) overcurrent,
    - (ii) main power supply failure;
    - (iii) control power failure;
    - (iv) where a steering gear hydraulic fluid reservoir is fitted it shall be provided with a low level alarm,
    - (v) phase failure alarm on the load side of the starter.
  - (c) dimming devices may be fitted in accordance with section 3 (23),
  - (d) remote steering control stations shall include items (a) and (b); the audible device may be omitted if the bridge alarm can be heard at the remote steering positions.
- 11.13 The supply for each steering gear remote control system shall have its own individual circuit supplied from the respective steering gear power circuit, or directly from the switchboard busbars adjacent to the steering gear power circuit in addition the steering gear power circuit shall also supply each of the monitoring devices required in Section 11.12 (a) and (b).
- 11.14 Where the steering gear is electrically operated by remote control from the bridge, or from other remote steering control stations there shall be provided two independent electric control systems.
- 11.15 Where fitted, “jog” steering control handles shall be of a type that requires a positive action to initiate operation.
- 11.16 The control of each steering gear motor is to be such that the motor will restart automatically upon restoration of voltage after a power failure.
- 11.17 Means shall be provided to effectively communicate between the bridge and steering gear compartment.
- 11.18 Steering gear motors are to be controlled from the bridge, the steering gear compartment; control may also be provided at other control stations; however when control from more than one position is provided, the over-riding control shall be at the bridge while the vessel is under way.
- 11.19 Machinery space ventilation fans, boiler fans, fuel oil transfer pumps, fuel oil pressure pumps and lube oil transfer and purifiers shall be provided with a means for stopping from a position outside the machinery space which will always be accessible in the event of fire in the space, in passenger vessels the accommodation and vehicular ventilation fans shall be provided with a means of stopping and motor indication at the main fire control station.
- 11.20 The emergency means for stopping machinery space ventilation fans, accommodation ventilation fans and vehicular space ventilation fans shall be separate and completely independent of each other.
- 11.21 The means provided for remote stopping of the electrical equipment required by subsection 11.19 shall be so arranged that a separate power source is not required to accomplish remote emergency stopping; the source of power provided in order to accomplish remote emergency stopping shall be:
- (i) provided from each individual motor control circuit; or
  - (ii) from a dedicated source of power feeding an individual motor, or group of motors connected to a motor control centre for a particular space, shunt trip arrangements shall not be permitted.
- 11.22 The activation of a remote emergency stop circuit, manually initiated, shall continue until it is manually reset.

- 11.23 Together with the manually initiated stopping devices for the galley ventilation fans located in the galley, the range/fryer gas smothering system shall also initiate a galley ventilation shut down
- 11.24 Where refrigerated lockers of the walk-in type can be locked so that they cannot be opened from inside, a “locked-in” alarm system shall be provided and shall comprise:
- (a) an on-off switch located inside at the exit of each such space,
  - (b) a visual and audible alarm located in the galley or other space where persons are normally present or employed; and
  - (c) a nameplate for both the actuator and the alarm to designate the function.
- 11.25 A branch circuit having a current rating not exceeding 15 amps may supply any number of lighting points; the total connected load of the sub-circuit shall not exceed 80% of the set current of the final sub-circuit protective device unless the final sub-circuit protective device is certified and marked for continuous operation at 100% of its rating.
- 11.26 When the total connected load is not known, a branch circuit having a current rating not exceeding 15 amps may supply any number of lighting points up to the following maxima:
- (a) at voltages up to and including 50V-10 points;
  - (b) from 51V up to and including 130V-14 points; or
  - (c) from 131V up to and including 230V-18 points.
- 11.27 A branch circuit of rating exceeding 20 amperes is not to supply more than one point.
- 11.28 Where two or more distribution panels or panel-boards are connected to a cable and the cable is looped from board to board without passing through a protective device, the cable conductors shall be of the same cross-sectional area throughout except where the length between panels is less than 2 metres.
- 11.29 Where an automatic sprinkler system is installed in accordance with the Fire Detection and Extinguishing Equipment Regulations:
- (a) there shall be not less than two independent sources of power supply for the sprinkler seawater pump and automatic alarm and detection system,
  - (b) one supply for the pump shall be taken from the main switchboard and one from the emergency switchboard by separate feeders reserved solely for that purpose,
  - (c) the feeders shall be arranged so as to avoid galleys, machinery spaces and other enclosed spaces of high fire risk except insofar as it is necessary to reach the appropriate switchboards and shall be run to an automatic change-over switch situated near the sprinkler pump; this switch shall permit the supply of power from the main switchboard so long as a supply is available therefrom and be so designed that, upon failure of that supply, it will automatically change-over to the supply from the emergency switchboard;
  - (d) the switches on the main switchboard and the emergency switchboard shall be clearly labelled and normally kept closed; no other switch shall be permitted in the feeders concerned; and
  - (e) one of the sources of power supply for the alarm and detection system shall be an emergency source.
- 11.30 Where an automatic fire alarm and fire detection system is required the system shall be in accordance with Section 21.6.
- 11.31 Separate branch circuits shall be provided for every motor required for an essential service and for every motor rated at 1.25 kW or more.
- 11.32 Lighting circuits shall be supplied by branch circuits separate from those for heating and for power requirements; this does not preclude the supply from lighting circuits of cabin ventilating fans, wardrobe heaters, anti-condensation heaters or small power consumers up to 600 watts.

- 11.33 If a ship is divided into fire zones, at least two separate circuits for lighting shall be provided in each zone, one of which may be the circuit for the emergency lighting.
- 11.34 A lighting circuit in a bunker or hold shall be provided with an isolating switch and visual indication outside the space which shall be accessible only to authorized personnel and provision shall be made for the complete isolation and locking in the “off” position of the means of control of every such circuit.
- 11.35 Electric lighting in main propelling machinery spaces, other large machinery spaces and on passenger ships, in alleyways and stairways leading to boat decks and in public rooms shall be supplied from at least two final sub-circuits, one of which may be the emergency circuit, in such a way that failure of any one of the circuits does not reduce the lighting to an inadequate level; lighting circuits shall be arranged so as to provide an adequate level of illumination on the fronts of switchboards and control panels; circuits and fittings for this purpose may form an integral part of the switchboard or control panel.
- 11.36 Where single-phase ac branch circuits are connected into three-phase or three-phase, 4-wire or single-phase, 3-wire distribution panels, the circuits shall be so disposed that the load will be balanced within 15% at the individual distribution panel; for dc branch circuits connected into 3 wire dc distribution panels, the circuits shall be similarly arranged.
- 11.37 Navigation lights shall be connected by means of a length of heavy duty flexible cable to a watertight receptacle outlet located adjacent thereto and each lamp shall be connected to it's branch circuit conductors by means of an individual heavy duty portable cable and a watertight receptacle plug or may be wired direct:
- (a) electric side, masthead, anchor and stern lights shall be controlled by an indicator panel located in an accessible position under the control of the officer of the watch;
  - (b) each such light shall be controlled and protected in each insulated pole by a switch and fuses or circuit breaker mounted on the indicator panel referred to in paragraph (a),
  - (c) each such light shall be provided with an automatic indicator which gives aural or visual warning, or both, in the event of extinction of the light and if:
    - (i) an aural device alone is used, shall be connected to a separate source of supply; or
    - (ii) a visual signal is used which is connected in series with the light, means shall be provided to prevent the extinction of the light due to the failure of the visual signal,
    - (iii) on small vessels where the condition of the navigation light can be observed from the manoeuvring position automatic failure of the lamp indicator need not be fitted.
  - (d) for vessels 15 metres or greater the indication light panel shall be provided with a means to transfer a navigation light to the respective alternate lamp by means of a suitable selector switch located in the indicator panel;
  - (e) provision shall be made on the bridge to select an alternative main supply circuit by means of a transfer switch located at the indicator panel,
  - (f) the feeders supplying a navigation light panel shall be protected by over-current devices rated or set at not less than twice the rating of the line protection in the navigation light panel: the navigation panel shall be fitted with main over-current devices rated or set greater than the maximum load including spares of the panel for each feeder and with branch protection rated or set at not less than 3 amperes in each conductor, for voltages under 55 volts refer to section 51.7; and
  - (g) the period of time required for the alternate supply to the navigation lights control panel shall be in accordance with the applicable group in Schedule 1.

FIGURE 11-3 SEMI-AUTOMATIC NAVIGATION LIGHT PANEL

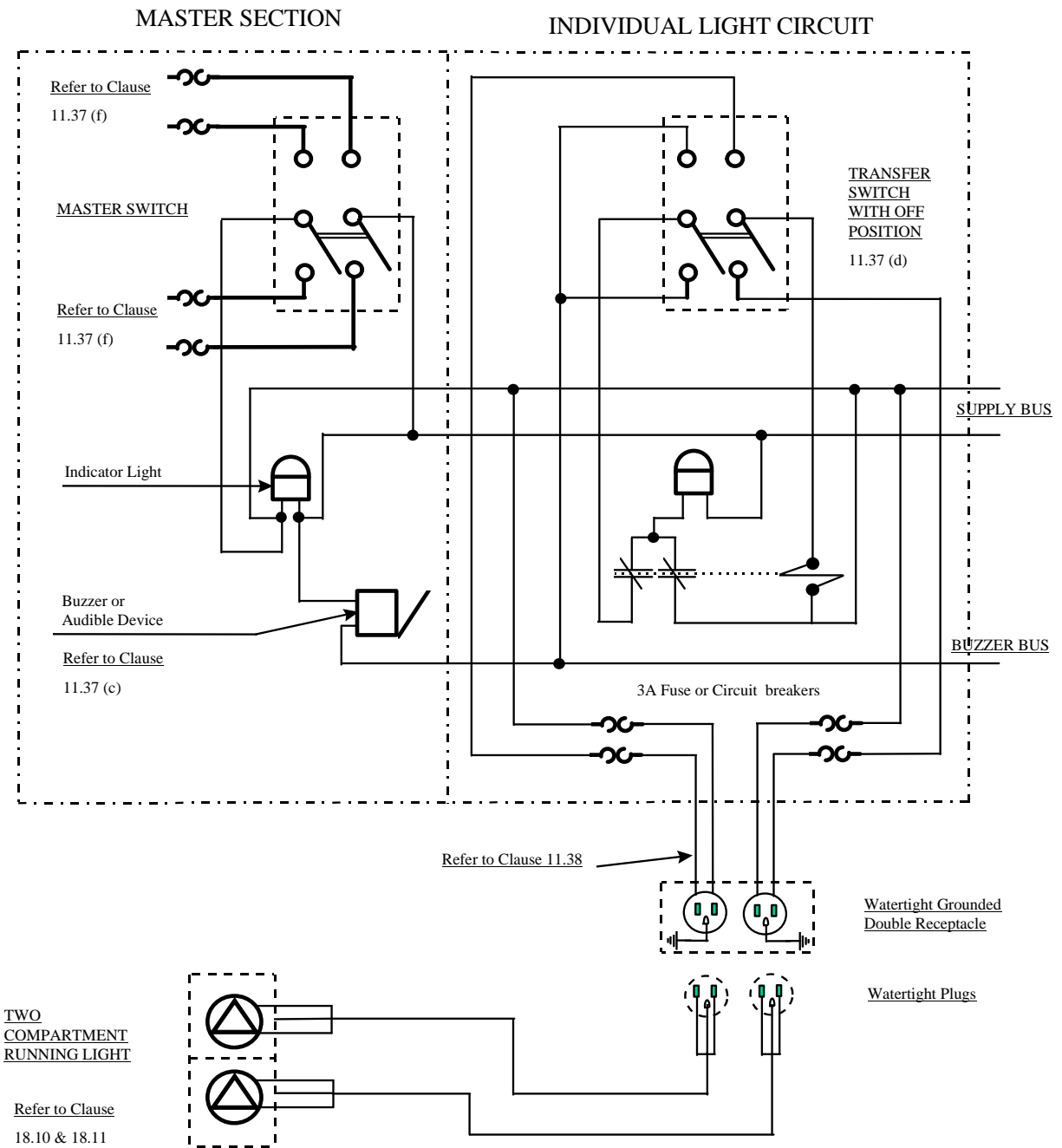

- 11.38 The wiring between the indicator panel and the watertight duplex receptacle at the side, masthead, anchor and stern lights shall be in duplicate and may be either two, 2-conductor cables or one 4-conductor cable.
- 11.39 Where arrangements are made for the supply of electric power from an external source on shore or elsewhere, a suitable connection box shall be installed in a position in the ship suitable for the convenient reception of flexible cables from the external source, having terminals of ample size and suitable shape to facilitate a satisfactory connection:
- (a) except for single-phase shore power arrangements fitted in accordance with paragraph (e), all shore power connections shall be provided with a ground connection terminal for connecting the vessel's hull to the shore ground,
  - (b) the shore connection shall be provided with an indicator at the main switchboard in order to show when the cable is energized,
  - (c) means shall be provided for checking the polarity for dc and single-phase ac systems and the phase sequence for three-phase ac of the incoming supply in relation to the ship's system; and
  - (d) bolts, nuts and washers used to maintain contact on bus and connection bars shall be of non-ferrous material or of steel rendered corrosion-resistant by zinc-electroplating or an equivalent process,
  - (e) for vessels that may experience excessive induced electrolysis as a result of a shore power installation fitted in accordance with paragraph (a), an alternative shore power connection arrangement may be fitted as follows:
    - (i) provided with an isolating transformer that has the transformer case electrically isolated from the transformer core,
    - (ii) the isolating transformer case grounded to the vessel's hull or to the continuous ground conductor for vessels constructed of wood or composite materials,
    - (iii) the exterior of the shore power cable connection plug on the vessel must be effectively encapsulated and insulated; and
    - (iv) a series of sketches, depicted in figures 11-1 and 11-2 are provided for reference.

**FIGURE 11-2 ISOLATION TRANSFORMER SYSTEM WITH SINGLE PHASE 240 VOLT INPUT AND 120/24- VOLTAGE PHASE OUTPUT WITH GF PROTECTION OF TRANSFORMER PRIMARY**

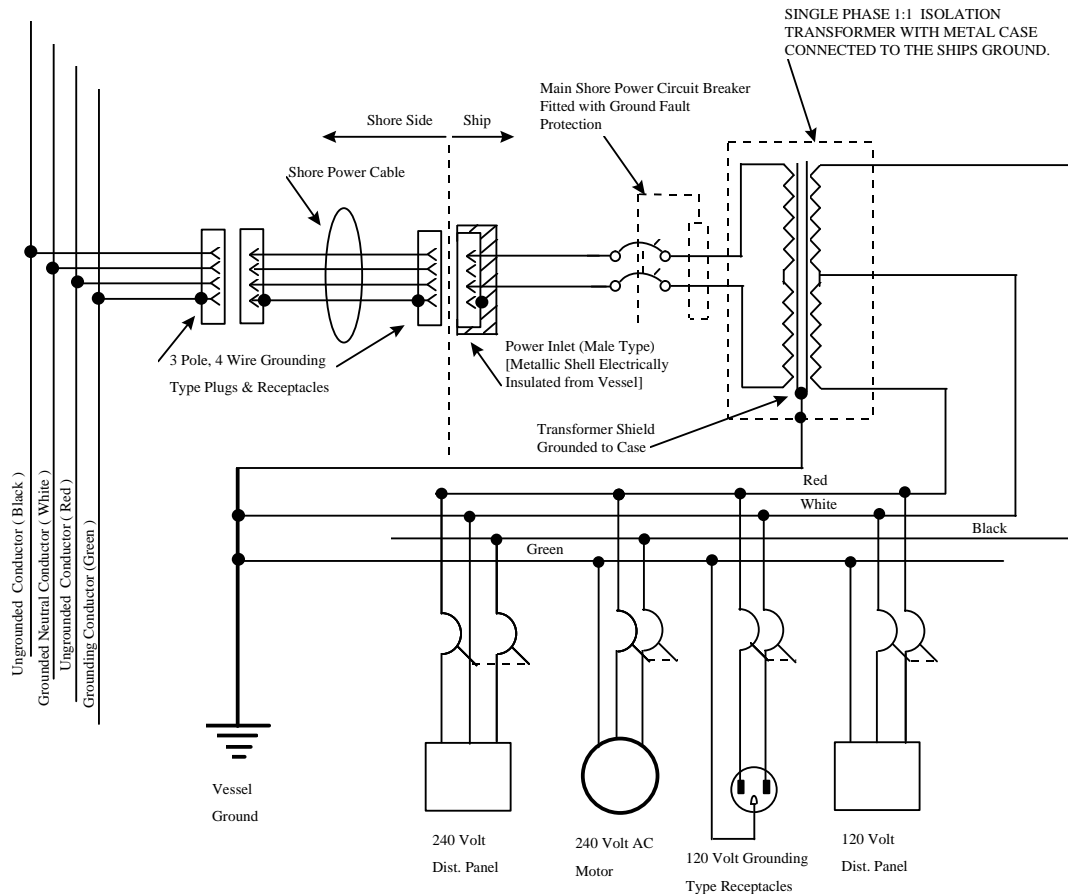

- 11.40 Vessels that utilize a grounded distribution system are to be provided with a suitable means to prevent the flow of load current through the hull or the grounding hardware while connected to shore power facilities.
- 11.41 Transformers for power and lighting shall be protected in accordance with Section 26, Part I of the Canadian Electrical Code.
- 11.42 Automatic changeover switches, relays and circuit breakers shall not be operated by a separate, remote or auxiliary power source.
- 11.43 Magnetic switches used for automatic bus transfer shall be of the latched type with coils energized only at the moment of operation.

## 12. CONSTRUCTION OF CABLES

- 12.1 Electrical cables and flexible cords for lighting, power, propulsion and communication circuits for marine installations shall be constructed and tested by a certifying authority to one of the most recent editions of the following standards:
- |                           |  |
|---------------------------|--|
| IEEE Std. 45-1998         | Recommended Practice for Electric Installations on Shipboard                                 |
| IEC 60092-3               | Part 3 Cables (Construction and Testing and Installation)                                    |
| IEC 60092-350             | Low Voltage Shipboard Power Cables 0 to 0.6 kV   |
| IEC 60092-351             | Insulating Materials for Shipboard Power Cables  |
| IEC 60092-353             | Single and Multi Power Cables Extruded Solid Insulation 0.6, 1 kV                            |
| IEC 60092-354             | Single and Three Conductor Power Cables Extruded Solid Insulation 0.6, 1 kV 6kV, 10kV & 15kV |
| IEC 60092-376             | Multi Cores  |
| UL 1309/CSA C22.2 No. 245 | Marine Shipboard Cables  |
| C22.1                     | Canadian Electrical Code Part 1 (Flexible Cables and Cords)                                  |
- 12.2 Cables and flexible cords for lighting, power, propulsion and communication circuits in marine installations shall have stranded copper conductors and, where necessary for compatibility with the insulation shall be tinned or alloy-coated.
- 12.3 Marine cables shall be of the “flame-retardant” type, except for final circuits where installed in metallic conduit; the “flame-retardant” tests shall be conducted in accordance with the most recent edition of:
- (a) IEEE Standard 45 1998; and be in accordance with IEEE Std. 1202-1991 or
  - (b) where cables have been constructed to an IEC Publication be in accordance with IEC Publication 332 Part 3 Category A/AF Flame Test; or
  - (c) Cables constructed to UL 1309/CSA 22.2 No. 245 CSA 22.2 No. 3 FT4
  - (d) specialised cable for communication, data and information transmission shall be in accordance with CSA Standard 22.2 No. 3 FT 4; or
    - (i) installed in accordance with Section 13.44.
- 12.4 Where cables are required to be fire resistant, the tests shall be conducted in accordance with the most recent edition of IEC Publication 60331.
- 12.5 All marine cables shall have a impervious non-metallic jacket, which shall be compatible with the insulation and; be in accordance with subsections 12.3 and 12.6; if an armour is provided it shall be a basket weave bronze braid type; other materials for the armour may be aluminum alloy, galvanized wire, or tinned coated copper.
- 12.6 The use of a protective covering of steel wire armour, steel tape armour, metal braid armour marine cables for use in circuits where the nominal voltage exceeds 1000 volts, shall be optional only where cable is not installed in hazardous locations.
- 12.7 In addition to subsection 12.1 marine cables for power, propulsion, lighting and control shall include a low temperature performance rating measured by impact at -35°C and bending tests at -40°C in accordance with the most recent C.S.A. Standard C22.2 number 0.3.
- 12.8 Marine cables shall be provided with a durable printing or embossing on the jacket or a marker under the cable jacket in accordance with IEEE Standard 45 1998 Clause 8.8, UL1309/CSA C22.2 No 245 Clause 5, or IEC 92-3.



- 12.9 The current carrying capacities of the various marine cable types shall be in accordance with the following:
- (a) for cables constructed to IEEE Std-45 1998, current carrying capacity shall be in accordance with the Table IEEE Std 45 9-1; or
  - (b) for cables constructed to IEC Standard 350 series or IEC 60092-3, current carrying capacity shall be assigned in accordance with the table contained in the respective standard; or
  - (c) for cables constructed to UL 1309/CSA 22.2 No. 245, current carrying capacity shall be assigned in accordance with the table contained in Table 12.1; or
  - (d) for marine cable installations where the current carrying capacities of either (a) or (b) are not available the values assigned by Table 12-1 may be used.
- 12.10 Fiber Optic cables shall be constructed and tested in accordance with a recognised certifying authority.
- 12.11 Fiber Optic cables shall be flame retardant type with tests conducted in accordance with subsection (3), where this is not possible installation shall be in accordance with Section 13.44.
- 12.12 The construction of fiber optic cable that may pass through or enter a hazardous zone shall be such that escape of gases to a safe area is not possible through the cable.
- 12.13 Conductor colour coding shall be identified by either coloured conductor insulation, tapes or by printing the colour nomenclature on the insulation or covering; coloured conductors of distribution systems shall be identified by the following:
- two conductors      black, white or red
  - three conductors    black, white or blue, red
  - four conductors     black, white or blue, red, orange, or green \*;
- \* If a conductor is being used as a grounding conductor (normally not a current carrying conductor) in a distribution system it must be coloured green.*
- 12.13.1 The use of a numbering system printed on the insulation would be an acceptable alternative to colour coding provided the ground conductor is identified as above.
- 12.14 Portable cables employed on travelling cranes and similar installations shall be C.S.A. certified extra hard usage in accordance with Table 11 of CSA 22.2 Part 1.
- 12.15 Branch circuit feeders shall not have conductors less than AWG #14 (1.5 mm<sup>2</sup>) wire.
- 12.16 Where the allowable current carrying capacity of the conductor does not correspond with a standard rating or setting of fuses or circuit breakers the next higher rating or setting may be selected provided it does not exceed 150 % of the allowable current carrying capacity of the conductor and the ambient operating temperature differs from 45°C , Table 12-1 (5) shall be considered with the exception of section 10.3 steering gear circuits and branch circuits section 11.25.
- 12.17 The cross sectional area of conductors shall be not less than the following:
- (a) 1.5mm<sup>2</sup> (14awg) for power, lighting and branch feeders;
  - (b) 1.0 mm<sup>2</sup> (18 awg) for control and, essential or emergency signalling or communication cables, except those cables assembled by the equipment manufacturer; and
  - (c) those in accordance with Section 9.3.9.

**TABLE 12-1****Maximum Current Carrying Capacity for Insulated Copper Wires and Cables**

(Single or Double Banked)

Values in amperes

45°C Ambient

750 Volts or Less (AC or DC)

DIMENSION DU CONDUCTOR			TYPE 1/C			TYPE 2/C			TYPE 3/C		
mm <sup>2</sup>	10 <sup>3</sup> milsci rc.	awg	T/T,N7 5°C	E,X8 5°C	S,M9 5°C	T/T,N 75°C	E,X8 5°C	S,M9 5°C	T/T,N 75°C	E,X8 5°C	S,M9 5°C
625	-	-	755	894	1006	642	760	855	529	626	704
600	736	872	981	626	741	834	515	610	687		
	1,000	-	662	784	882	563	666	750	463	549	617
500	-	656	778	875	558	661	744	459	545	613	
	950	-	641	760	854	545	646	726	449	532	598
	900	-	620	734	826	527	624	702	434	514	578
	850	-	598	709	797	508	603	677	419	496	558
	800	-	576	682	767	490	580	652	403	477	540
400	-	571	677	761	485	575	647	400	474	533	
	750	-	533	655	737	470	557	626	387	459	516
	700	-	529	628	706	450	534	600	370	440	494
	650	-	506	599	674	430	509	573	354	419	472
	600	-	481	570	641	409	485	545	337	399	449
300	-	-	477	565	636	405	480	541	334	396	445
	550	-	455	540	607	387	459	516	319	378	425
	500	-	429	509	572	365	433	486	300	356	400
240	-	-	415	492	553	353	418	470	291	344	387
	450	-	402	476	536	342	405	456	281	333	375
	400	-	373	442	498	317	376	423	261	309	349
185	-	353	418	470	300	355	400	247	293	329	
	350	-	343	407	458	292	346	389	240	285	321
	300	-	312	370	416	265	315	354	218	259	291
150	-	-	309	367	412	263	312	350	216	257	288
	250	-	278	330	371	236	281	315	195	231	260
120	-	-	269	319	359	229	271	305	188	223	251
	212	4/0	251	297	335	213	252	285	176	208	235
95	-	-	232	276	310	197	235	264	162	193	217

	168	3/0	217	257	289	184	218	246	152	180	202
70	-	-	192	228	256	163	194	218	134	160	179
	133	2/0	188	222	250	160	189	213	132	155	175
	106	1/0	163	193	217	139	164	184	114	135	152
50	-	-	156	184	208	133	156	177	109	129	146
	83.7	1	140	166	187	119	141	159	98	116	131
35	-	-	125	148	166	106	126	141	88	104	116
	66.4	2	121	144	162	103	122	138	85	101	113
	52.6	3	105	124	140	89	105	119	74	87	98
25	-	-	101	120	135	86	102	105	71	84	95
	41.7	4	91	108	121	77	92	103	64	76	85
	33.1	5	79	93	105	67	79	89	55	65	74
16	-	-	76	91	102	65	77	87	53	64	71
	26.3	6	68	81	91	58	69	77	48	57	64
	20.8	7	59	70	78	50	60	66	41	49	55
10	-	-	57	67	76	48	57	65	40	47	53
	16.5	8	51	60	68	43	51	58	36	42	48
6		-	41	49	55	35	42	47	29	34	39
	10.4	10	38	45	51	32	38	43	27	32	36
4	-	-	32	38	43	27	32	37	22	27	30
	6.53	12	28	34	38	24	29	32	20	24	27
2.5	-	-	24	28	32	20	24	27	17	20	22
	4.11	14	21	25	32	18	21	27	15	18	22
1.5	-	-	17	21	26	14	18	22	12	15	18
1.25	-	-	15	18	23	13	15	20	11	13	16

**NOTES**

1. The values given above have been calculated for an ambient of 45°C and assume that a conductor temperature equal to the maximum rated temperature of the insulation is reached and maintained continuously in the case of a group of four cables bunched together and laid in free air.
2. The current rating values given in Table 1 (and those derived there from) may be considered applicable, without correction factors for cables double banked on cable trays, in cable conduits or cable pipes, except as noted in NOTE 3.
3. When more than six cables which may be expected to operate simultaneously at their full rated capacity are laid close together in a cable bunch in such a way that there is an absence of free air circulation around them, a correction factor of 0.85 is to be applied to the current ratings obtained from table 1.
4. These current ratings are applicable for both armored and unarmored cables.
5. If ambient temperature differs from 45°C, the values in Table 1 are to be multiplied by the following factors:

MAXIMUM CONDUCTOR TEMPERATURE	AMBIENT CORRECTION FACTOR			
	40°C	50°C	60°C	70°C
75°C	1.08	0.91	0.71	---
85°C	1.06	0.94	0.79	0.61
95°C	1.05	0.95	0.84	0.71

6. Where the numbers of conductors in a cable exceeds, as in control cables, the maximum current carrying capacity of each conductor is to be reduced as in the following table.

NO. OF CONDUCTORS	% OF 3-4/C TYPE VALUES IN TABLE 1
5 - 6	80
7 - 24	70
25 - 42	60
43 and above	50

7. When mineral cable is installed in such a location that its copper sheath is liable to be touched when in service, the current is to be multiplied by the correction factor 0.80 in order that sheath temperature does not exceed 70°C.

INSULATION TYPE DESIGNATION	MAXIMUM CONDUCTOR TEMPERATURE, °C
T, T/N Polyvinyl Chloride and Moisture Resisting	75
X Cross-Linked Polyethylene	85
E Ethylene Propylene Rubber	85
M Mineral (MI)	95 *
S Silicone	95

A maximum conductor temperature of 250°C is permissible for special applications and standard end fittings may be used provided the temperature does not exceed 85°C at the end fittings, however, when the temperature at the end fitting is higher than 85°C special consideration will be given to an appropriate end fitting.

### 13. INSTALLATION OF CABLES

- 13.1 All cables shall be so constructed, installed and protected as to prevent danger to the ship and personnel.
- 13.2 The rated voltage of any cable shall be not less than the maximum voltage of the circuit for which it is used.
- 13.3 Cables exposed to voltage surges associated with highly inductive circuits shall, as a minimum, be insulated for 600 volts.
- 13.4 Cables or flexible cords shall not be installed in any location where the maximum conductor temperature, under normal conditions, exceeds the appropriate value set forth in Table 12-1.
- 13.5 Polyvinyl chloride insulated cables shall not be used in refrigerated spaces unless special low temperature PVC suitable for 40°C is used.
- 13.6 Cables having a sheath or covering of polyvinyl chloride shall not be used in refrigerated spaces or in any situation where it is necessary for them to pass through watertight bulkhead glands or deck tubes, unless special low temperature PVC is used in refrigerated spaces and heat resisting quality PVC is used through bulkheads or decks.
- 13.7 In machinery spaces and refrigerated spaces, or in wet or damp locations, cables shall, unless run in steel conduit or steel pipe, be:
  - (a) mineral insulated, copper sheathed;
  - (b) polychloroprene sheathed, or PVC sheathed, with or without braid; or
  - (c) thermosetting or thermoplastic sheathed with or without braid.
- 13.8 Main feeder cables for supplying power to elevators shall be installed outside the hoistway; only such electrical wiring, conduit and cable used directly in connection with the elevator, including wiring for signals, for communication with the car, for lighting and ventilating the car and wiring for fire detecting systems for hoistways, may be installed inside the hoistway.
- 13.9 All cables, other than travelling cables, installed for any purpose in an elevator shaft, shall, unless enclosed in rigid metal conduit, be:
  - (a) armoured;
  - (b) impervious sheathed and braid armoured; or
  - (c) mineral insulated, copper sheathed.
- 13.10 Cables shall as far as is practicable, be fixed in accessible positions, so chosen that the cables are not exposed to drip or accumulation of water or oil, steam or oily vapour, high temperature from boilers, steam pipes, exhaust pipes, radiators, resistors, or other hot objects or mechanical damage.
- 13.11 Cables, unless adequately protected shall not be laid under machines or floor plates.
- 13.12 Cables shall not be led across expansion joints in the superstructure unless this is unavoidable; where cables must cross an expansion joint they shall be arranged with a loop suitably supported and having an internal radius not less than twelve times the overall diameter of the largest cable, to ensure the necessary flexibility.
- 13.13 All cables within 9 metres of any receiving antenna system, radio room or radio navigation apparatus, unless a metallic deck or bulkhead intervenes, shall be metal sheathed, metal braided or otherwise adequately screened, or arranged so as to prevent the radiation or reception of interfering spurious signals.
- 13.14 Cables, other than those feeding services in a radio room shall not be installed therein, but cables which must pass through a screened radio room shall be run throughout their length within the room, in continuous metallic conduit or trunking which shall be bonded to the screening of the room at the points of entry and exit.

- 13.15 All cables which must enter the radio room shall be grouped together, so far as is practicable, so that they enter at one point only and when the radio room is screened, the screening of the cables entering the room shall be bonded to the room screening at the point of entry.
- 13.16 All cables supplying the services to an unscreened radio room shall pass through suitable interference filters at the point of entry of the cables into the screened sections, unless they terminate in equipment which in itself provides adequate screening and suppression.
- 13.17 Cables carrying pulses of high amplitude, and power cables supplying units in which such pulses are present, shall be segregated from cables for other services.
- 13.18 Where a cable is bent, the internal radius of the bend shall be not less than the appropriate value set forth in Table 13-1.

**TABLE-13-1****Bending Radius of Cables**

INSULANT	FINISH	OVERALL DIAMETER	MINIMUM INTERNAL RADIUS OF BEND TIMES OVERALL DIAMETER OF CABLE
E, P, S, T, X	Non-armoured	Not exceeding 9.5 mm & includes (*)	3
(*) for both armour or unarmoured	"	Exceeding 9.5 mm but not exceeding 25.4 mm & includes (*)	4
	"	Exceeding 25.4 mm & includes (*)	6
	Armoured	Any	6
M	Copper sheath	Any	6

- 13.19 Portable cords or portable cables shall not be used for fixed wiring.
- 13.20 Cables terminating in equipment capable of generating high temperatures, such as lighting fixtures, electric heaters, etc. shall be suitable for operation at the temperature of the fixture without sustaining damage to the insulation.
- 13.21 With the exception of low voltage communications circuits, joints in all electrical conductors are to be made in junction or outlet boxes; the splicing of cables shall comply with the requirements of subsections 13.39, 13.40 and 13.41.
- 13.22 Connections and terminations shall comply with the following:
- (a) each connection to a conductor or terminal part of conductor that is larger than No. 10 A.W.G. (5.3 mm<sup>2</sup>) must be made within an enclosure and have:
    - (i) a pressure-type connector on each conductor;
    - (ii) a solder lug on each conductor;
    - (iii) a splice made with a pressure-type connector to a flexible lead or conductor; or
    - (iv) a splice that is soldered, brazed or welded to a flexible lead or conductor.
  - (b) each connection to a conductor or a terminal part of a conductor that is No. 10 A.W.G. (5.3 mm<sup>2</sup>) or smaller must be made within an enclosure and:
    - (i) meet paragraph (a) of this subsection; or

- (ii) have clamps or screws with terminal plates that have up-turned lugs or other suitable means to capture the terminal;
  - (c) a connector or lug of the set screw type must not be used except if it is equipped with a non-rotating follower that travels with the setscrew and makes pressure contact with the conductor;
  - (d) where twist-on type connectors are used the connections shall be made within an enclosure and the insulated cap shall be secured to prevent loosening due to vibration;
  - (e) wire connectors utilized in conjunction with screw-type terminal blocks must be of the captive type such as the ring or the flanged spade type;
  - (f) each pressure-type wire connector and lug must meet ANSI/UL-486A-1997 (American National Standards Institute / Underwriters Laboratories).
- 13.23 Cables shall be effectively supported and secured in order to prevent chafing or other injury.
- 13.24 Where the weight of cables is independently supported by a metallic cable support system, the spacing of the cable clips or restraints may be increased to maximum of 1 metre.
- 13.25 Metallic staples shall not be used for fixing any cables.
- 13.26 Permanently installed cables shall be secured by corrosion-resistant, flame-retardant cable restraints having smooth edges and so rounded that the cables remain tight without their coverings or insulation being damaged.
- 13.27 Where non-metallic cable restraints are used to secure cables in wireways or metallic trays which are mounted in the vertical or inverted position, metallic brackets or metallic cable straps suitably positioned and adequate to support the weight of the cables, shall be provided.
- 13.28 All metal coverings of cable shall be electrically continuous throughout their entire length and shall be effectively grounded to the hull of the ship at both ends, except for branch circuits which may be grounded at the supply end only; the metallic braid or sheath shall be terminated at the gland or connector at which the cable enters the enclosure and shall be in good electrical contact with the enclosure.
- 13.29 Metallic cable support systems used for supporting cables, unless of corrosion-resistant material, shall be galvanized, or provided with equally effective protective coatings applied before erection.
- 13.30 All cables passing through watertight decks or watertight bulkheads shall be provided with deck tubes or watertight glands or transits as appropriate.
- 13.31 Where cables passing through beams, non-watertight bulkheads, etc., the openings through which they pass shall be finished in a manner that will prevent chaffing of cables during installation and throughout the life of the vessel.
- 13.32 Where single-core cables are used for ac circuits and dc circuits with high ripple content rated in excess of 20 amperes:
- (a) the armour, if any, shall be of non-magnetic material;
  - (b) if installed in steel conduits or pipes, or steel casing, the cables shall always be so bunched that the cables of all phases and the neutral, if any, are in the same conduit, pipe or casing;
  - (c) magnetic materials shall not be used between single-core cables of a group; where the cables pass through steel plates, all the conductors of the same circuit shall pass through a non-ferrous plate or gland so that there is no magnetic material between the cables, and the clearance between the cables and magnetic material shall not be less than 75 mm; and
  - (d) the orientation and length of single-conductor metal-sheathed, armoured or non-armoured cables in parallel, with respect to each other and to those in other phases, shall be such as to minimize the difference in inductive reactance and the unequal division of current.

Note: For guidance regarding "Configurations for Installation in Parallel of Single Conductor Cables" refer to appendix B, Part I, Canadian Electrical Code.

- 13.33 The braid or metallic sheath of cables shall be terminated at the point of entry into the enclosure.
- 13.34 The ends of mineral-insulated, copper-sheathed cables shall be so sealed as to prevent the ingress of moisture; such sealing materials and any material used to insulate the conductors where they emerge from the insulation shall have adequate insulating and moisture-resisting properties and shall retain these properties throughout the range of temperatures to which the cable-end is to be subjected in service.
- 13.35 Cables shall not be installed in, or be in direct contact with, oil fuel tanks.
- 13.36 Except as provided hereafter, conductors of similar conductivity in sizes #1/0 AWG (53.5 mm<sup>2</sup>) and larger may be in parallel provided they are:
- (a) free of splices throughout the total length;
  - (b) the same cross-sectional area;
  - (c) the same type of insulation;
  - (d) the same length; and
  - (e) terminated at both ends in a connector specifically designed for use with conductors in parallel or in individual connectors on a solid bus-bar with a separate screw or stud for each connector to ensure equal division of current.
- 13.37 Conductors of similar conductivity may be run in parallel to supply control power to indicating instruments and control provided:
- (a) they are contained within one cable;
  - (b) the ampacity of each individual conductor is sufficient to carry the entire load current shared by the paralleled conductors; and
  - (c) the overcurrent protection is such that the ampacity of each individual conductor will not be exceeded if one or more of the paralleled conductors becomes inadvertently disconnected.
- 13.38 All vital power, control and signal cables shall avoid high fire and damage risk areas such as galleys, machinery spaces, hazardous zones etc., except where necessary to provide services to the particular space.
- 13.39 Where the following conditions apply, the method of splicing cables shall be in accordance with subsections 13.40 and 13.41:
- (a) cables installed in a sub-assembly spliced to cables installed in another sub-assembly;
  - (b) for a vessel receiving alterations, a cable spliced to extend a circuit;
  - (c) a cable having a large size or exceptional length spliced to facilitate installation;
  - (d) a cable spliced to replace a damaged section of the cable if, before replacing the damaged section, the insulation resistance of the remainder of the cable is measured and it is determined that the condition of the insulation is unimpaired.
- 13.40 All cable splices are to be made by a qualified person using a one-cycle compression tool; all cable splices are to have the following:
- (a) **a pressure-type butt connector which meets ANSI/UL-486A-1997( American National Standards Institute / Underwriters Laboratories);**
  - (b) replacement insulation that has:
    - (i) the same or greater thickness than that of the original cable insulation;
    - (ii) electrical properties that are the same as or better than the electrical properties of the cable original insulation;



- (iii) the heat transfer capability that is the same as or better than that of the original cable insulation;
  - (c) a watertight replacement jacket that is heat shrinkable or pre-stretched tubing of the same or greater thickness than that of the original cable jacket and that has properties that are the same as or better than those of the original cable jacket; this includes meeting the jacket requirements of IEEE Standard 45 1998 Section 8.9 and Tables 8-9 and 8-10;
  - (d) for armoured cable, replacement armour or a jumper that connects to the cable armour on each side of the splice and that maintains the electrical continuity of the cable armour;
  - (e) all material in a cable splice must be chemically compatible with all other material in the splice and with the materials of the cable;
- 13.41 A cable must not be spliced in a hazardous area.
- 13.42 A multi-conductor cable shall not contain circuits of different voltages except for the following:
- (a) where the conductors within the multi-core serve circuits which constitute part of the same system;
  - (b) that the device to which the conductors are connected to are insulated for at least the same voltage as that of the circuit having the highest voltage; and
  - (c) terminal or connection boxes into which the multi-conductor enters shall have each voltage clearly and permanently identified and effective barriers provided within the enclosure to separate each voltage.
- 13.43 Non-metallic conduit shall not be installed within accommodation spaces, control stations, hazardous locations and service spaces.
- 13.44 Fiber Optic and speciality cables which have unique construction qualities such as coaxial cables etc. that are not in accordance with Section 12.3 shall be installed in accordance with the following:
- (a) installed in accordance with the manufactures recommendations with particular attention to the radius of bends to avoid crushing or twisting and extreme pulling tension;
  - (b) to be physically separated from all other cables;
  - (c) have a fire stops provided at:
    - (i) vertically each deck level except where the levels are common between decks;
    - (ii) each penetration of an A or B class boundary;
    - (iii) cable entry to equipment;
    - (iv) in a cableway that has an A-60 fire rating;
    - (v) in the accommodation, horizontally every fifteen (15) metres.
- 13.45 The splicing of fiber optic cables shall be of approved mechanical or fusion methods as per the manufacturers instructions.
- 13.46 When equipment or cables to be installed which may produce or be susceptible to Electro-Magnetic Induction (EMI) then consideration should be given to the following:
- (a) their location;
  - (b) their proximity to other equipment or cables;
  - (c) the construction of the cable;
  - (d) their bonding and/or grounding as per the manufacturers instructions or recommendations.
- 13.47 Propulsion cables shall not have splices where it is necessary to replace cables due to damage the terminations shall be made in a terminal box sealed against the ingress of moisture or air and provides the terminations protection from mechanical damage.

## 14. TRANSFORMERS FOR POWER AND LIGHTING

- 14.1 Transformers, except those used for motor starting shall be double-wound (two separate windings); auto-transformers shall be used only for reduced voltage motor starting or other special applications.
- 14.2 Transformers shall be installed in well-ventilated compartments, accessible only to authorized personnel except that air-cooled transformers provided with means of protection against accidental contact with live parts need not be installed in special compartments.
- 14.3 Liquid-cooled transformers shall be housed in a metallic compartment having adequate means for drainage of liquid leakage; the cooling liquid shall be non-flammable and non-toxic.
- 14.4 Suitable arrangements shall be provided for cooling and containing all the liquid which might escape from a damaged tank.
- 14.5 Transformers and their connections shall be protected against mechanical damage, condensation and corrosion.
- 14.6 Suitable terminals, clearly marked, shall be provided in an accessible position, convenient for external connections; the terminals shall be effectively secured and shall be so spaced or shielded that they cannot be accidentally grounded, short-circuited or touched.
- 14.7 Liquid-cooled transformers shall be of the conservator type and shall be so designed that, under all conditions with the ship inclined  $22\ 1/2^\circ$  from the normal or when the trim is  $10^\circ$ , they operate without risk of spilling liquid; if provision is made for breathing, a suitable dehydrator shall be provided.
- 14.8 Where transformers constitute an essential part of the electrical supply system necessary for maintaining the auxiliary services indispensable for the propulsion and safety of the ship, they shall be of sufficient rating and number and so arranged as to ensure that transformer failure will not prevent the supply of power to the indispensable auxiliary services.
- 14.9 Where transformers are arranged to operate in parallel, their coupling groups shall be compatible and their no-load voltage ratios equal; the rated output of the smallest transformer in the group shall be not less than half the rated output of the largest transformer in the group.
- 14.10 All transformers shall be capable of withstanding without damage, the effects of a short circuit at the terminals of any winding for two seconds duration.
- 14.11 The temperature rise of dry type transformers, measured during continuous operation at the maximum rating, shall not exceed the limits given in Table 14-1.

**TABLE 14-1****Dry Type Transformers**

Limits of Temperature Rise for Continuous

**Duty – Degrees Celsius Based on 40°C. Ambient**

<b>COPPER TEMPERATURE RISE BY RESISTANCE</b>						<b>HOTTEST SPOT TEMPERATURE RISE</b>				
	Insulation Class					Insulation Class				
Part	A (105sys)	E	B (150sys)	F (185sys)	H (220sys)	A	E	B	F	H
Insulated winding	55	70	80	115	150	65	85	110	145	180

NOTE: Metallic parts in contact with or adjacent to insulation shall not attain a temperature in excess of that indicated for the hottest spot copper temperature in the above table adjacent to that insulation.

- 14.12 Transformers which are equipped, and which are designed for forced air cooling, shall be fitted with an alarm at the main control station, which will indicate either of the following conditions:
- (a) loss of ventilation; or
  - (b) high temperature.

## 15. STATIC POWER SUPPLY UNITS

- 15.1 These units employ semi-conductor components to effect power conversion as follows:
- (a) AC - DC: Rectifiers including Battery Charging Rectifiers and DC Power Supplies
  - (b) DC - AC: Inverters
  - (c) AC - AC: Frequency Converters (Changers)
  - (d) DC - DC: Voltage Converters
  - (e) UPS Systems: Uninterruptible Power Supply Systems
- 15.2 The units shall be provided in adequately designed steel cabinets or enclosures, either floor or wall mounted as required.
- 15.3 Convection cooling without forced ventilation is to be preferred.
- 15.4 Where openings are required in the top of the cabinet to facilitate or enhance natural convection cooling, such openings shall be protected by a suitable drip cover.
- 15.5 Where forced ventilation must be employed, the circuit shall be designed upon loss of cooling air, to:
- (a) trip the power supply to the unit; or
  - (b) activate and alarm at the main control station.
- 15.6 The units shall be installed in such a manner that the circulation of cooling air shall not be impeded or restricted, and so that the ambient temperature of the inlet air to the enclosure does not exceed that specified for the unit operating environment.
- 15.7 The units shall not be mounted near heat sources.
- 15.8 Circuit breakers or fuses shall be provided to protect the input and output of the units.
- 15.9 Mercury-type fungus protection, even in minute quantities, will damage selenium-type rectifier cells and shall not be used in their vicinity.
- 15.10 For units designed to operate in parallel with other equipment, precautions shall be taken to ensure that, within the specified loading conditions, load sharing is such that overloading of any unit does not occur and that the combination of the parallel equipment is stable.
- 15.11 Inverters:
- 15.11.1 The safety of the vessel shall not be compromised by the installation of Inverters over 1 kW used for non-essential services.
  - 15.11.2 Inverters shall be bonded to the vessels ground conductor in accordance with Section 4.
  - 15.11.3 Receptacles fed from an inverter shall be grounded to the vessel ground in accordance with Section 4.
  - 15.11.4 Distribution systems fed from an inverter shall be fitted with a suitable means of indicating ground faults.
  - 15.11.5 Inverters shall be fitted with a Voltmeter to indicate the output voltage.

## 16. GENERATING PLANT AND MOTORS

- 16.1 When the number and ratings of the required ship's service generating sets is determined, consideration shall be given to the normal and maximum demand loads as well as the safe and efficient operation of the ship when at sea and in port; the number and rating of generating sets shall be sufficient to ensure the operation of the auxiliary services indispensable for the propulsion and safety of the ship, even when one generator or its prime mover is out of service.
- 16.2 In addition, for ac ship's service generators consideration shall be given to the starting kVA and power factor of squirrel cage motors particularly in regard to the effect of the magnitude and duration of resulting transient voltage changes.
- 16.3 When ac generating sets operate in parallel and are carrying initially the minimum load necessary for the operation of the ship, they shall have sufficient reserve capacity to permit the starting of the largest idle motor on the system without causing any operating motor to stall or any adverse effect on other equipment due to the transient voltage variation.
- 16.4 Prime movers for driving electrical generators intended for supplying ship's service systems shall be continuously rated; generating plant for ship's service shall be suitable for continuous duty at the full and rated load; they shall have an overload capability comparable with the overload capability of the driven generators; each prime mover shall, in addition, be under the control of an efficient operating governor capable of limiting the speed, when full load is suddenly removed, to at least 5 per cent less than that of the overspeed trip setting; the overspeed trip shall also be equipped with a means for manual tripping.
- 16.5 Where a turbine-driven dc generator is arranged to run in parallel with other generators, a switch with normally closed contacts shall be fitted on each turbine emergency governor to open the generator circuit breaker when the emergency trip functions.
- 16.6 The automatic governing characteristics of the prime movers for ac generating sets operating in parallel shall be such that, for loads within the limits of 20% and 100% of the total connected generating capacity, the load of any generating set does not normally differ from its proportionate share of the total load by more than 25% of its full rating, or 15% of the rated full load output of the largest machine, whichever is the less.
- 16.7 Each generator shall be provided with suitable terminals or leads clearly marked, in an accessible position, convenient for external connections and effectively secured, spaced and shielded so that they cannot accidentally be grounded, short-circuited or touched; the generator terminals shall be enclosed in a terminal box so constructed that the incoming cables can be led into it in a manner which will not impair the original integrity of the box.
- 16.8 The temperature rise of each of the various parts of ac and dc motors and generators when tested in accordance with their rating, shall not exceed the values set forth in Tables G, H and I, based on an ambient temperature as stated in section 16 of these Standards.
- 16.9 Classes of insulation A, B, F and H shall be in accordance with the most recent edition of Publication No. 85 issued by the International Electrotechnical Commission.
- 16.10 Means shall be provided to enable the voltage of each generator to be adjusted.
- 16.11 Each ac service generator, unless of the self-regulated type, shall be provided with a separate automatic voltage regulator capable of withstanding shipboard vibrations.
- 16.12 Emergency generators shall be capable of establishing voltage without auxiliary means under all conditions of operation.
- 16.13 The equipment provided for adjusting the voltage of d.c. generators shall be capable of varying the voltage at any load between no load and full load to within:
- (a) 0.5% of rated voltage for generators of rating exceeding 100 kW ; or
  - (b) 1.0% of rated voltage for generators of ratings not exceeding 100 kW.

- 16.14 The inherent voltage regulation of ship's service dc generators designed in relation to the speed regulation and governing of the prime movers shall be as follows:
- (a) Shunt or stabilized shunt-wound generators rated at 25 kW and above, shall comply with the following requirements:
    - (i) when the voltage has been set at full load to its rated value, the removal of the load shall not cause a permanent increase of the voltage greater than 15% of the rated voltage; and
    - (ii) when the voltage has been set either at full load or at no load, the voltage obtained at any value of the load shall not exceed the no-load voltage;
  - (b) compound-wound generators rated at 25 kW and above shall be so designed in relation to the governing characteristics of the prime mover that, with the generator at full-load operating temperature and starting at 20% load with voltage within 1% of rated voltage, it shall give at full load a voltage within 1.5% of rated voltage; the average of ascending and descending voltage regulation curves between 20% load and full load shall not vary more than 3% from rated voltage; and
  - (c) ship's service generators which are of the shunt type shall be provided with an automatic voltage regulator; an automatic voltage regulator shall also be provided for all ship's service generators driven by variable speed engines used also for propulsion purposes whether these generators are of the shunt, stabilized shunt or compound-wound type.
- 16.15 The excitation system of ac generators rated 25 kW and above shall comply with the following requirements:
- (a) each ac generator for ship's service driven by its prime mover having governor characteristics complying with subsection 16.6 shall be provided with an excitation system capable of maintaining voltage under steady conditions within plus or minus 2.5% of rated voltage for all loads between zero and rated load at rated power factor; these limits may be increased to plus or minus 3.5% for emergency sets;
  - (b) when the generator is driven at rated speed, giving its rated voltage and it is subjected to a sudden change of symmetrical load within the limits of specified current and power factor, the voltage shall not fall below 85% nor exceed 120% of the rated voltage; the voltage of the generator shall then be restored to within plus or minus 3% of the rated voltage for the main generator sets in not more than 1.5 seconds; for emergency sets these values may be increased to plus or minus 4% and not more than 5 seconds respectively; in the absence of precise information concerning the maximum values of the sudden loads, the following conditions shall be assumed: 60% of the rated current with a power factor of between 0.4 lagging and zero to be thrown on with the generator running at no load, and then withdrawn after steady state conditions have been reached; and
  - (c) under short-circuit conditions, the generator with its excitation system shall be capable of maintaining a current of at least three times its rated value for a duration of up to 2 seconds, unless protection selectivity requirements exist which allow a shorter duration and provided that, in any case, the safety of the installation is assured.
- 16.16 When ac generators are operated in parallel, the reactive loads of the individual generating sets shall not differ from their proportionate share of the total reactive load by more than 10% of the rated reactive output of the largest machine or 25% of the smallest machine where this value is less than the former.
- 16.17 The design of dc generators and their connections shall be such that when they operate in parallel, the individual load on each machine does not normally differ from its proportionate share of the load by an amount greater than 12% of the rated full load of the largest machine or 25% of the rating of the individual machine in question; this requirement applies when the combined load on the sets is varied between 20% and 100% of the combined ratings; such load sharing shall not result in over-loading the smaller set; for each generator of a group required to run in parallel, the voltage drop across the series field and its connection to the switchboard shall be approximately equal.

- 16.18 DC generators which are required to run in parallel shall be stable in operation at all loads from no load to full load.
- 16.19 The series windings of 2-wire dc generators shall be connected to the negative terminal of the machine.
- 16.20 Every equalizer connection shall have a cross-sectional area not less than half that of the negative connection from the generator to the switchboard.
- 16.21 The components of the excitation system for ac generators, including automatic voltage regulation, if used, shall be of a type suitable for shipboard conditions and be capable of operating under all specified conditions of steady and transient load, including short-circuit.
- 16.22 Where water cooling is used, the cooler shall be so arranged as to avoid entry of water into the machine whether by leakage or condensation in the heat exchanger.
- 16.23 Means shall be provided to prevent accumulation of moisture and condensation within the machines, especially when they are idle for appreciable periods.
- 16.24 Machines shall be so constructed that when running at any and every working speed, all revolving parts are well balanced.
- 16.25 Measures shall be, if necessary, taken to prevent the circulation of current between the shaft and the bearings.
- 16.26 Generators and motors shall have efficient and continuous lubrication at all probable inclinations, running speeds and all normal working bearing temperatures.
- 16.27 Means shall be provided to prevent the lubricant from creeping along the shaft or otherwise gaining access to the insulation of the machine or any live part thereof.
- 16.28 Every oil-lubricated bearing shall be provided with a suitable overflow which, while permitting efficient lubrication when the machine is running, prevents the bearings from containing excess of oil.
- 16.29 Where ring lubrication is employed, the rings shall be so constrained that they cannot leave the shaft.
- 16.30 Every machine of rating 100 kW or greater having self-lubricated sleeve bearings shall be fitted with a bearing inspection lid and means for visual indication of bearing oil level.
- 16.31 Shafting materials for motors and generators above 375 kW which are essential to the safety of the ship shall be constructed, installed and inspected in accordance with Schedule VI of the Marine Machinery Regulations.
- 16.32 Space heaters are to be supplied integral with all generators; these heaters shall be energized at any time that the temperature of the windings or metal parts of the generator are lower than the ambient temperature; the heaters shall be placed in such a location that warm air will pass over the windings and commutator; this movement of air may be accomplished by convection or forced air circulation; the following table shows recommended size of heater in terms of weight, excluding shaft.

WEIGHT OF GENERATOR IN KILOGRAMS	WATTS OF SPACE HEATER
0 - 454	100
454 - 1361	250 - 500
1361 - 2722	500 - 1000
2722 - 4636	1000 - 1250
above 4636	200 watts / 1000 kg

- 16.33 Electronic governors controlling the speed of the prime-mover for ship's service ac generators and ship's service dc generators shall have two power supplies, one of which shall be a battery; in the event of a "normal" supply failure the governor shall be automatically transferred to the "alternative" battery power supply; an audible and/or visual alarm shall be provided in the main machinery control area to indicate that the governor has transferred to the battery supply; the prime mover shall be equipped with a separate overspeed device to prevent runaway if a failure should render the governor inoperative; the alternative battery supply shall be arranged for trickle charge to ensure the battery is always in a fully charged state; each governor shall be protected separately so that a failure in one governor will not cause failure of other governors; a mechanical back up governor may be provided in lieu of the alternative battery supply; the mechanical governor shall be of a suitable type and shall automatically assume control of the engine in the event of electronic governor failure.
- 16.34 Ship's service alternating-current generators of 500 kW and above, shall be provided with means for obtaining the temperatures of the stationary windings; a minimum of one embedded temperature detector per phase is to be provided for this purpose on the hot end of the machine; the temperatures are to be indicated at a convenient location, preferably the generator control panel.

**TABLE 16-1**

LIMITS OF OBSERVABLE TEMPERATURE RISE FOR DC MOTORS  
AND GENERATORS BASED ON 50°C AMBIENT TEMPERATURE

ITEM	MACHINE PART	TYPE OF ENCLOSURE	METHOD OF TEMPERATURE DETERMINATION	CLASS OF INSULATION			
				A	B	F	H
1	Armature Windings	Driproof & open Totally Enclosed	Thermometer Resistance	40	60	80	100
				60	90	120	145
			Thermometer Resistance	45	65	85	105
				60	90	120	145
2	Multi-layer Field Windings	Driproof & open Totally Enclosed	Thermometer Resistance	40	60	80	100
				60	90	120	145
			Thermometer Resistance	45	65	85	105
				60	90	120	145
3	Single-layer field windings with exposed un-insulated surfaces and bare copper windings	Driproof & open Totally Enclosed	Thermometer Resistance	50	70	95	120
				60	90	120	145
			Thermometer Resistance	55	75	100	125
				60	90	120	145
4	Cores and mechanical parts in contact with or adjacent to the insulation	Driproof & open Totally Enclosed	Thermometer	40	60	80	100
			Thermometer	45	65	85	105
5	Commutators and collector rings	All	Thermometer	55	75	95	115



**TABLE 16-2**

LIMITS OF OBSERVABLE TEMPERATURE RISE FOR AC GENERATORS  
BASED ON 50°C AMBIENT TEMPERATURE

MACHINE	METHOD OF TEMPERATURE DETERMINATION	CLASS OF INSULATION			
		A	B	F	H
<b>Armature Windings</b>					
(a) All ratings	Resistance	50	70	95	115
(b) 1563 kW and less	Embedded Detector	60	80	105	130
(c) Over 1563 kW	Embedded Detector	55	75	100	125
<b>Field Windings</b>					
(a) Salient Pole	Resistance	50	70	95	115
(b) Cylindrical Rotor	Resistance	-	75	95	115

**TABLE 16-3**

LIMITS OF OBSERVABLE TEMPERATURE RISE FOR AC MOTORS

Machine Part	Method of Temperature Determination	Ambient 50m C Class of Insulation			
		A	B	F	H
<b>Windings</b>					
(a) All but (b) and (c)	Resistance	50	70	95	115
(b) Totally enclosed non-ventilated enclosures only					
(c) Encapsulated only	Resistance	55	75	100	125
(d) 1100 kW and less	Embedded Detector	55	75	100	-
(e) over 1100 kW	Embedded Detector	60	80	105	130
	Embedded Detector	55	75	100	125
<b>Field Windings of Synchronous Motors</b>					
(a) Salient Pole	Resistance	50	70	95	115
(b) Cylindrical Rotor	Resistance	-	75	95	115

**17. CONTROL GEAR**

- 17.1 The limits of temperature rise for motor starters and controllers, contactors, field rheostats and rheostats for other purposes shall be based on the cooling-air temperature specified in Section 2 of these Standards.
- 17.2 The temperature limits under normal working conditions, when measured by thermometer, shall satisfy the following requirements:
- (a) Resistors: The temperature rise of issuing air when measured 25 mm from the enclosure shall not exceed 175°C. Any part of the enclosure, the temperature rise of which might exceed 35°C shall be guarded to prevent against accidental contact by personnel or flammable material;
  - (b) Coils: The temperature rise under normal conditions of service of release, blowout, contactor, operating and relay coils shall not exceed:

CLASS OF INSULATION	TEMPERATURE
A	Thermometer 60°C Resistance 80°C
B	Thermometer 90°C Resistance 110°C
E	Thermometer 75°C Resistance 95°C
F	Thermometer 110°C Resistance 130°C

- (c) Contacts: the maximum temperature rise allowed for contacts in air shall be as follows:
    - (i) Solid Copper Contacts 70°C,
    - (ii) Laminated Copper Contacts 65°C, and
    - (iii) Silver or similar Contacts 75°C.
- 17.3 Resistors shall be adequately guarded or enclosed to preclude accidental contact by personnel or flammable material.
- 17.4 Motors shall be provided with means of disconnecting both motor and controller from all supply conductors, except that a manually operated switch or circuit breaker, suitable as a controller, may serve as both controller and disconnecting means; for motors rated not more than 1.5 kW and not more than 250 volts, the manual starting switch may serve as a disconnect provided it has an ampere rating not less than twice the rated current of the motor; in grouped motor control arrangements, the disconnecting means shall be so interlocked with the hinged door of the associated motor controller as either to prevent the controller door from being opened while the circuit is energized or to cause the disconnect device to open in the event that the controller door is opened.
- 17.5 Glazed windows of enclosing cases shall be as small as practicable, consistent with their purpose, and suitable protection shall be arranged against breakage of the glass.
- 17.6 Every electric motor shall be provided with:
- (a) efficient means of starting and stopping, the latter so placed as to be easily operated by the person controlling the motor;
  - (b) efficient means for preventing automatic re-starting after a stoppage due to a drop in voltage or complete failure of the supply, where unexpected re-starting of the motor is considered a hazard; and

- (c) except for steering gear motors, means for the automatic disconnection of the supply in the event of current becoming excessive owing to mechanical overloading of the motor.
- 17.7 Ungrounded conductors of motor control, interlock and indicator circuits shall be protected by a fuse of capacity not exceeding 30 amps except where:
- (a) steering gear circuits are involved;
  - (b) the opening of the circuit would create a hazard;
  - (c) both sides of the circuit do not extend beyond the controller enclosure;
  - (d) the rating or setting of the branch circuit over-current device does not exceed 500% of the control circuit wiring ampacity; or
  - (e) the impedance of the control transformer feeding the circuit is such as to prevent overloading of the external circuit.
- 17.8 Where the primary means of isolation is remote from a motor, one of the following shall be provided:
- (a) an additional means of isolation fitted adjacent to the motor; or
  - (b) provision made for locking the primary means of isolation in the “OFF” position; or
  - (c) provision made so that the fuses in each line can be readily removed and retained by authorized personnel.
- 17.9 Working voltage of remote control devices shall not exceed 250 volts.
- 17.10 Overload heaters in motor starters shall be assigned on the basis of actual nameplate data.
- 17.11 Motor starters and controllers having hinged doors exceeding a height of 114 cm or a width of 60 cm shall be provided with door positioners

**TABLE 17-4****COLOURS OF INDICATING LIGHTS**

(DOES NOT APPLY TO COLOURS FOR NAVIGATION LAMPS)

COLOURS	MEANING	EXPLANATION	TYPICAL APPLICATIONS
Red	Danger or alarm	Warning of danger or situation which requires immediate action	Stop of essential machine, for example, steering gear motor, lube. oil pump for main engine. Temperature or pressure valves at critical levels. Loss of essential circuit.
Yellow	Caution	Change or impending change of conditions	Temperature and pressure valves which differ from the normal levels, but not critical
Green	Safety (Normal operating and working)	Indication of a safe working situation	Machine running normal. Liquid circulating. Pressure, temperature, current, within limits.
Blue	Instruction/ Info. (specific meaning assigned according to the need in the case considered)	Blue may be given specific meaning which is not covered by the three above colours	Motor ready to start. No-Load, generator ready to be connected. Electrical heating circuits.
White	No specific meaning (neutral)	Any meaning may be given which is not covered by the four above colours.	Ground indication, synchronizing lights, appliances, automatically controlled.

## 18. LIGHTING FIXTURES

- 18.1 Lampholders shall be constructed wholly of flame-retardant and non-hygroscopic material and supports of live parts shall be of non-combustible material.
- 18.2 Lighting fixtures shall be designed to provide for adequate dissipation of heat from the lamps and to prevent accidental contact with the bulb by flammable materials; they shall be constructed to protect the bulb from mechanical damage and to prevent the emission of broken glass bulb particles.
- 18.3 All lighting fixtures shall be arranged so as to prevent rises in temperature that would be injurious to the electrical wiring or that could result in a risk of fire in the surrounding material.
- 18.4 The temperature of those parts of the lighting fixture which can be handled shall not exceed 60°C, and the temperature of the terminals to which insulated cables are to be connected shall not exceed the values set forth in Table 13-1 of Section 13.
- 18.5 Lamps in positions involving risk of mechanical damage shall be installed in fixtures of substantial construction and shall be protected against such damage.
- 18.6 Shades shall be of flame-retardant material.
- 18.7 Lamps which are in positions exposed to the weather, spray, drip or condensed water shall be enclosed in weatherproof fixtures and lamps which are used near readily combustible material shall be installed in totally enclosed fixtures.
- 18.8 In wet locations, those parts of a lampholder likely to be touched by a person replacing a lamp shall be constructed of or shrouded in insulating material.
- 18.9 All running, standing and signal electric lights shall be substantially constructed of non-corrodible material and shall be made watertight.
- 18.10 Each electric starboard, port, masthead, range and stern light shall be fitted with single filament lamps.
- 18.11 Where duplicate electric navigation lights are fitted, the optical system of each electric navigation light shall consist of two glass lenses placed one above the other so as to make each section an individual lighting unit and to prevent light reflection passing from one section to the other; each section shall contain a light placed at the radius of the lens and arranged so that the lamp filament is located at the focal centre of the lens.
- 18.12 Anchor lights may be of the single-filament, one-light electric type.
- 18.13 All fittings, inductors, capacitors and other auxiliaries used with tubular fluorescent lamps shall be of a type suitable for marine use.
- 18.14 Fittings, reactors, capacitors and other auxiliaries for fluorescent lighting fixtures shall not be mounted on surfaces which are subject to high temperatures; in ships for unrestricted service they shall be capable of operating at estimated ambient temperatures given in section 2 of these Standards.
- 18.15 Every capacitor having a rated capacitance of 0.5 microfarad or over, shall be provided with a means for its prompt discharge.
- 18.16 Every inductor and high-reactance transformer shall be installed as near as practicable to its associated discharge lamp.
- 18.17 All live parts of a lighting installation shall be provided with effective screens of grounded metal or insulating material of mechanical strength adequate to withstand the conditions of normal service and the insulating material used for this purpose shall be non-combustible, moisture-resisting and anti-tracking.
- 18.18 The voltage of the primary circuits of transformer-fed discharge lighting systems shall not exceed that permitted in Table 7-1 of Section 7.3 of this standard.
- 18.19 No discharge lamp circuit shall use an rms voltage exceeding 5,000 volts to ground, measured on open circuit.

- 18.20 Ancillary equipment for high voltage installations, including inductors, capacitors, resistors and transformers shall be either totally enclosed in a substantial grounded metal container, which may form part of the lighting fitting or, alternatively, shall be placed in a suitable ventilated enclosure of non-combustible material or of fire-resisting construction which is reserved for high voltage apparatus.
- 18.21 A notice “DANGER, HIGH VOLTAGE” and “DANGER HAUT TENSION” shall be placed and maintained on every container or enclosure of high voltage discharge lamps that are accessible to unauthorized persons; the word “DANGER” shall be in block letters not less than 10 mm high and the words “HIGH VOLTAGE” and “HAUT TENSION” in letters not less than 5 mm high; the letters shall be painted red on white background and the size of each notice shall not be less than 65 mm by 50 mm overall.
- 18.22 Fluorescent lighting fixtures shall be constructed with adequate guards to protect the tubes from mechanical damage and to prevent the emission of broken glass particles.
- 18.23 Fluorescent lighting fixtures equipped with ballasts shall be integrally protected against the rise of temperature above the rated temperature of the fixture.

## 19. ACCUMULATORS / STORAGE BATTERIES

### 19.1 General

- 19.1.1 Accumulator batteries shall be of lead-acid or of nickel-alkaline type, with due consideration being given to suitability for a specific application or location. The batteries may be either the vented or the valve regulated sealed electrolyte type.

### 19.2 Construction

- 19.2.1 The cells of vented batteries shall be so constructed as to prevent spilling of electrolyte due to an inclination of the ship of 30° from the normal and the emission of electrolyte spray.
- 19.2.2 Batteries shall not be tapped for voltages other than the total voltage of all the cells comprising the battery.

### 19.3 Assembly

- 19.3.1 A vented battery shall be arranged so that each cell is accessible from the top for inspection, testing, adding electrolyte, or cleaning and the units which form the battery shall be assembled in a tray of wood or other suitable material.
- 19.3.2 When batteries are arranged in two or more tiers, all shelves, except the lowest, shall have not less than 50mm space front and back, for circulation of air.
- 19.3.3 Every battery shall have each unit supported on insulators of vitreous porcelain, ebonite or equivalent material, which may form an integral part of the container, and insulators of similar material shall be employed to prevent any movement of the cells arising from the motion of the ship.
- 19.3.4 Each individual battery bank shall be provided with a durable nameplate securely attached, bearing the manufacturer's name and address and type designation, the ampere hour rating at a specific rate of discharge for both the vented and sealed type batteries. The vented battery nameplate shall also indicate the specific gravity of the electrolyte when fully charged.
- 19.3.5 The interior of all battery compartments including crates, trays, boxes, shelves and other structural parts therein shall be protected against the deteriorating effect of the electrolyte by:
- (a) electrolyte-resisting coating; or
  - (b) lining of electrolyte-resisting material.
- 19.3.6 The lining of metal shelves shall be watertight and, for lead-acid batteries the lining shall be of lead sheet, with a minimum thickness of 1.5 mm and carried up to not less than 75 mm on all sides; for alkaline batteries the shelves shall be lined with steel in a similar manner and, the linings shall be not less than 0.8 mm thickness.

### 19.4 Installation and Location

- 19.4.1 Batteries shall be located where they are not exposed to excessive heat, extreme cold, spray, steam or other conditions which would impair performance or accelerate deterioration.
- 19.4.2 Batteries shall not be installed in sleeping quarters.
- 19.4.3 Vented batteries shall be so located that adjacent equipment is not rendered inoperative through corrosion by battery gases.
- 19.4.4 Starter batteries shall be located as close as practicable to the engine or engines served, to limit voltage drop in cables at the high currents required.
- 19.4.5 Alkaline batteries and lead acid batteries shall not be located in the same compartment or enclosure.

- 19.4.6 Vented batteries connected to a charging device with a power output of more than 2.4 kW (calculated from the maximum obtainable charging current and the nominal voltage of the battery) shall be installed in a room assigned to batteries only, or in a suitable locker on the open deck if a room is not available.
- 19.4.7 Vented batteries connected to a charging device with a power output between 0.2 kW and 2.4 kW (calculated as in subsection 19.4.6) may be installed in a battery room or in a locker on deck, or in a box located on deck or in the engine room or in a similar well ventilated compartment.
- 19.4.8 Vented batteries connected to a charging device with a power output of less than 0.2 kW (calculated as in subsection 19.4.6) may be installed open, if protected from above from falling objects, or in a battery box in any suitable space.
- 19.4.9 Only electrical cables and lighting necessary for operational activities shall be installed in battery compartments where vented batteries are installed; such equipment shall be certified safe as Class 1 Zone 1 Group II C or Class 1 Division 1 Group B **as defined by the Canadian Electrical Code.**
- 19.4.10 Batteries of the sealed type may be installed in spaces in which standard marine or industrial equipment is installed provided they are protected from mechanical damage and the ventilation requirements are in accordance with section 19.5.10

## 19.5 Battery Ventilation

- 19.5.1 All rooms, lockers and boxes for storage batteries shall be arranged, and ventilated to avoid accumulation of flammable gas; batteries arranged in two or more tiers, shall have not less than 5 cm space, front and back, of all shelves, for circulation of air; and each tier or shelf shall be separated by a distance of at least 21 cm measured from the top of the bottom accumulator to the bottom of the shelf or tier immediately over.
- 19.5.2 Natural ventilation may be provided for batteries if ducts can be run directly from the top of the room to the open air above, with no part of the duct inclined more than 45° from the vertical; if natural ventilation is impracticable, mechanical exhaust ventilation shall be provided with exhaust at the top of the room and adequate openings for an inlet provided near the floor of battery rooms or the bottom of lockers or boxes.
- 19.5.3 The quantity of air expelled from battery rooms containing vented type batteries, if expelled by mechanical ventilation, shall be at least equal to:
- $$Q = 110 \times I \times n$$
- où
- Q = quantity of expelled air in litres per hour;
- I = maximum charging current during gas formation, or 25% of the maximum obtainable charging current of the facility, which ever is the greater;
- n = number of cells in series.
- 19.5.4 Battery lockers shall be ventilated similarly to battery rooms by a duct led from the top of the locker to the open air by an exhaust ventilation duct, but in machinery spaces and similar well ventilated compartments the duct may terminate not less than 1 m above the top of the locker.
- 19.5.5 Deck boxes for the storage of batteries shall be provided with a duct from the top of the box, terminating at least 1.2 m above in a goose-neck, mushroom-head or the equivalent, to prevent entrance of water; the entire deck box including openings for ventilation shall be sufficiently weathertight to prevent entrance of spray or rain.
- 19.5.6 Systems for mechanical ventilation of battery rooms shall be independent of ventilation systems for other spaces.



- 19.5.7 Any fan motor associated with a duct used to remove the air from a battery room shall be placed external to the duct unless it is certified safe for use in atmospheres containing hydrogen.
  - 19.5.8 Fans for battery spaces shall be so designed as to render sparking impossible in the event of the impeller tips touching the fan casing.
  - 19.5.9 Mechanical ventilation for battery rooms, battery lockers and battery boxes shall be fitted with an alarm, at the main control station, which will indicate loss of ventilation.
  - 19.5.10 The ventilation rates for those compartments where valve regulated (sealed batteries) are located may be lowered to not less than 25% of the requirements of section 19.5.3; however where vented batteries are located in the same compartment as sealed batteries the ventilation rate shall be in accordance with Section 19.5.3.
  - 19.5.11 Ventilation ducts for battery boxes and compartments shall be constructed of material that is resistant to the corrosive effects of battery gases.
- 19.6 Battery Charging Facilities
- 19.6.1 Charging facilities shall be provided and shall be such that without exceeding a safe charging rate a completely discharged battery can be charged to 80 percent of its capacity within a period of ten (10) hours.
  - 19.6.2 For batteries which normally stand idle for long periods, trickle charging to neutralize internal losses shall be provided.
- 19.7 Protection
- 19.7.1 Protection against reversal of the charging current shall be provided.
  - 19.7.2 For floating battery service, or for any other condition where the load is connected to the battery while it is on charge, the maximum battery voltage shall not exceed a safe value for any connected apparatus.
  - 19.7.3 Suitable means, including an ammeter and a voltmeter shall be provided for controlling the recharging of each storage battery and to protect against accidental discharge of the battery into the charging circuit.
  - 19.7.4 Rectifiers shall not be located in positions where they would be subjected to the gases vented from batteries.
  - 19.7.5 Where a battery is charged by equipment containing rectifiers, provision shall be made to prevent overloading of the rectifiers due to loads occurring during charging such as those required for starting an engine.
  - 19.7.6 The battery cables except those for engine starting, shall be protected by a switch and fuse(s) or circuit breaker in each conductor and located outside the battery compartment.

## 20. HEATING AND COOKING APPLIANCES

- 20.1 Electric ranges, heating and cooking appliances shall comply with the relevant requirements of the Sections 2.7 or 2.8 or as modified and supplemented herein.
- 20.2 The heating elements of heating appliances shall be suitably guarded and protecting guards shall be strong enough to resist being forced against any current-carrying part.
- 20.3 Electric space heaters in cabins, lockers and similar enclosed spaces, shall be of the convector type.
- 20.4 Electric space heaters forming part of the ship's equipment shall be fixed in position and shall be so constructed as to reduce the risk of fire to a minimum.
- 20.5 Electric space heaters shall not be constructed with an element so exposed that clothing, curtains or other similar material can be scorched or set on fire by heat from the element.
- 20.6 With the exception of single-phase cabin heaters directly controlled by thermostats, every heating and cooking appliance, whether portable or fixed, shall be controlled locally by a switch having an "off" position.
- 20.7 Each electric range, cooking appliance and individual heater or group of heaters within the same enclosed space shall have a temperature control device; temperature control devices rated to operate at line voltage shall have a current rating at least equal to the sum of the current ratings of the equipment they control; temperature control devices which can be turned automatically or manually to a marked "off" position and which either interrupt line current directly or control a contactor or similar device which interrupts line current shall open all conductors of the controlled heating circuit when in the "off" position; where a liquid to be heated is a fuel or other flammable product, temperature controls shall be installed to ensure that the liquid temperature does not exceed the minimum flash point of the liquid.
- 20.8 The operating voltage of thermostats for cabin heaters and for heaters mounted in ventilation trunks shall not exceed 250 volts.
- 20.9 Heaters in ventilating trunks and re-heat units shall be interlocked with the fan motor supplying air to the unit so that the contactor controlling the heater can only be energized when the fan is running; a certified overheat safety thermostat of the capillary tube type shall be provided and set to operate at a temperature not exceeding 110°C.
- 20.10 Appliances shall be so constructed and mounted that there will be no excessive heating of adjacent decks or bulkheads.
- 20.11 All electric cooking equipment, attachments and devices shall be of a rugged construction and so designed as to permit complete cleaning, maintenance and repair with ease; all servicing shall be possible from the front or top without moving the equipment.
- 20.12 Range, oven, broiler, fry kettle and griddle units shall be sectional; the design and construction of the equipment shall be such as to ensure strong, rigid, self-supporting units.
- 20.13 All component parts of cooking equipment shall be made of corrosion-resistant material, or, if steel, shall be adequately protected against corrosion.
- 20.14 Grab rails projecting out from the front on cooking equipment shall be provided for use by the crew in heavy seas.
- 20.15 Tank heaters utilizing electric elements shall be controlled by means of a temperature regulation device and shall also be provided with secondary protection which will open if the liquid attains a temperature exceeding 96°C for water and the manufacturer's recommended temperature for liquids other than water.

## 21. INTERIOR COMMUNICATIONS & ALARMS

- 21.1 Interior communication circuits used for audible and visual signals and communication of information from one place to another, within or on the vessel shall comply with the following:
- (a) switches, resistors, connection boxes, accessories, instruments and other apparatus shall be of robust design and so installed as to ensure an ample margin of safety, having regard to the voltage employed;
  - (b) where the voltage of supply exceeds 55 volts, switches, resistors, connection boxes, accessories, instruments and other apparatus shall be designed and installed throughout in all respects in accordance with the requirements applicable to power and lighting circuits;
  - (c) cables shall be constructed and installed in accordance with the requirements of Sections 12 and 13; and
  - (d) all circuits, other than those supplied from primary batteries shall be protected on each insulated pole by fuses of a current rating suited to the current rating of the circuit to be protected.
- 21.2 Wiring systems for interior communications essential for safety and for emergency alarm systems shall be arranged to avoid galleys, machinery spaces and other spaces having a high risk of fire except in so far as it is necessary to provide communication or to give alarm within those spaces.
- 21.3 On ships 500 gross tons or over, not equipped with bridge propulsion control and thus, where the engine order telegraph is the primary means of controlling speed and direction ahead or astern from the bridge, an audible and visual wrong direction alarm shall be provided in the engine room; similarly, on ships 500 gross tons or over, equipped with bridge propulsion control but also having an engine order telegraph for use when the ship is in engine room propulsion control, an audible and visual wrong direction alarm shall be provided in the engine room; the alarm shall operate whenever a control is operated in such a manner as to produce propulsive thrust in a direction opposite to that required by its engine order reply transmitter.
- 21.4 General Alarm System
- 21.4.1 General
- A general alarm system shall be provided as required by the Hull Construction Regulations; consisting of either vibrating bells or electronic bell-like devices; the distribution system shall be arranged as follows, or as a function of the public address system in accordance with Subsection 21.5 but in no case shall be a combination of both systems.
- 21.4.2 Requirements
- (a) each general alarm device shall produce a signal or tone distinct from any other audible signal on the vessel; the signal or tone shall be of sufficient sound intensity provide adequate sound coverage in a compartment or space;
  - (b) in certain areas where the ambient noise level is so high that audible devices alone would not be heard, they shall be augmented by flashing red lights or beacons which shall be of sufficient intensity and number and so located as to alert occupants of the space of an emergency; the flashing red lights or beacons shall be energized whenever the general alarm system with which they are associated is energized;
  - (c) the audible devices shall be automatically silenced when a voice communication is transmitted over the public address system and shall also be arranged to automatically continue operation upon completion of the voice transmission;
  - (d) the general alarm switch or contact maker shall be capable of remaining in the “on” position without supervision; the switch shall be located on the bridge at the main fire control panel adjacent to the public address system.

- (e) the wiring system shall be so arranged to avoid galleys, machinery spaces and other enclosed spaces having a high fire risk except in so far as it is necessary to provide sound coverage in such spaces or to reach the appropriate switchboard or distribution panel; and

#### 21.4.3 Power Supply

- (a) the general alarm system shall be capable of operating continuously for a period of time in accordance with the duration requirements of the ship's emergency power system as set forth in Schedule 1;
- (b) there shall be not less than two (2) independent sources of power supply reserved solely for the electrical equipment used in the operation of the general alarm system, one of which shall be an emergency source; such feeders shall run to an automatic change-over switch; or,
- (c) the system shall be arranged to operate on a floating battery in which the charging device shall be supplied from the final emergency power source; for those vessels because of design, operate the emergency services from individual batteries the charging device shall be supplied from the main switchboard essential services bus.
- (d) the general alarm feeder circuits shall be connected to the power source through fuses or circuit breakers which are fitted with one of the following:
  - (i) handles capable of being locked in the closed position; or
  - (ii) an indicator light or alarm, at the main control station, which will indicate loss of power;

#### 21.4.4 Distribution

- (a) The general alarm system shall have a feeder distribution panel provided to divide the system into the required number of zone feeders.
- (b) The feeder distribution panel shall be located in a space adjacent to the battery room if the power supply is a battery or in the emergency generator room if the power supply is the emergency generator.
- (c) There shall be at least one feeder circuit required for each vertical fire zone in which general alarm audible devices or flashing red lights or beacons are located;
- (d) There shall be provided for each vertical fire zone feeder a branch circuit distribution panel in which a minimum of one fused branch circuit provided for each deck level within the fire zone; the panel shall be located above the upper most continuous deck, or alternatively each deck branch circuit may terminate in the feeder distribution panel.
- (e) A deck branch circuit within a vertical fire zone shall not supply the audible devices and/ or lights or beacons on more than one deck level except where the levels of a space are common between decks;
- (f) Vessels which are not divided into vertical fire zones by main vertical bulkheads shall be divided into vertical fire zones not exceeding 40 metres and have a branch circuit provided for each deck level where general alarm audible device sand flashing red lights or beacons are required.

### 21.5 Public Address System

#### 21.5.1 General

A Public Address system shall be provided as required by the Hull Construction Regulations. The system shall provide effective means of communication throughout the accommodation, service spaces, machinery spaces control rooms muster and embarkation stations or both and in cargo ships of the self unloading type, the sound coverage shall include the tunnel areas and conveyor drive areas. This system may also provide the requirements for the general alarm system.

## 21.5.2 Requirements

- (a) the public address system controls shall be located adjacent to the general alarm controls at the main fire control station which shall be accessible to responsible members of the crew at all times whether in port or at sea.
- (b) the wiring system shall be so arranged to avoid galleys, machinery spaces and other enclosed spaces having a high fire risk except in so far as it is necessary to provide sound coverage in such spaces or to reach the appropriate switchboard or distribution panel.
- (c) a means shall be provided to silence all other audio distribution systems at the public address system station.
- (d) the overall performance of the system must not be effected by the failure of a single call station

## 21.5.3 Additional Requirements when Public Address System is employed as a General Alarm System

- (a) where the public address system amplifier is used to produce the signal or tone for the general alarm the contact maker shall activate all speakers in the system;
- (b) flashing red lights or beacons shall be supplied as required in accordance with Section 21.4.2(b);
- (c) the speakers shall not have external volume controls or local cut-out switches;
- (d) the amplifier and devices used to produce the signal or tone shall be duplicated.

## 21.5.4 Power Supply

- (a) there shall be not less than two (2) independent sources of power supply reserved solely for the electrical equipment used in the operation of the public address system; one of which shall be an emergency source; such feeders shall be run to an automatic change-over switch; or
- (b) the system shall be arranged to operate on a floating battery with the charging device supplied from the final emergency power source; for those vessels, because of design, operate the emergency services from individual batteries the charging device shall be supplied from the main switchboard essential services bus;
- (c) the public address system shall be capable of operating continuously for a period of time in accordance with the duration requirements of the ship's emergency power system as set forth in Schedule 1;

## 21.5.5 Distribution (when employed as a combination Public Address and General System)

- (a) where the public address system is used to produce the emergency general alarm it shall be divided into the required number of vertical fire zones and deck circuits;
- (b) the distribution of the circuits shall be from the public address system amplifier cabinet and shall be located above the uppermost continuous deck, or from a branch distribution panel located in each vertical fire zone;
- (c) there shall be at least one circuit required for each vertical fire zone in which the loud speakers or flashing red lights or beacons are located;
- (d) each branch circuit shall be protected against short circuit and shall not supply speakers or beacons on more than one deck level except where the levels of a space are common between decks;
- (e) on vessels not divided into fire zones by main vertical fire bulkheads, the vessel shall be divided into vertical zones not exceeding 40 metres in length and a branch alarm circuit provided for each such zone and on each deck where general alarm speakers or red flashing beacons are required.

## 21.6 Automatic Fire Detection and Fire Alarm Systems

## 21.6.1 General

An automatic and manual fire detection and fire alarm system shall be provided as required by the Hull Construction Regulations and shall be arranged as follows:

## 21.6.2 General Requirements:

- (i) any automatic fire detection and fire alarm system with manually operated call points shall be capable of immediate operation at all times;
- (ii) power supplies and electric circuits necessary for the operation of the system shall be monitored for loss of power or fault conditions as appropriate; occurrence loss of power of a fault condition shall initiate a visual and audible fault signal at the control panel and remote indicating units which shall be distinct from a fire signal;
- (iii) there shall be not less than two sources of power supply for the electrical equipment used in the operation of the fire detection and fire alarm system, one of which shall be an emergency source; a visual and audible alarm signal at the control panel and remote indicating units shall indicate when the normal supply has failed and the system is operating on the emergency or battery supply;
- (iv) the power supply shall be provided by separate feeders reserved solely for that purpose and such feeders shall run to an automatic changeover switch situated in or adjacent to the control panel for the fire detection system, or the system shall be arranged to operate on a dedicated floating battery with the charging device supplied from the final emergency power source and, shall be capable of operating continuously for a period of time in accordance with Schedule 1;
- (v) detectors and manual call points shall be grouped into sections and the activation of any detector or manual call point shall initiate a visual and audible fire signal at the main control panel and remote indicating units;
- (vi) if the signals have not received attention within two minutes, an audible alarm shall be automatically sounded throughout the crew accommodation and service spaces, control stations and machinery spaces of Category 'A';
- (vii) the alarm sounder system need not be an integral part of the detection system and may be part of the general alarm system; in passenger ships the audible devices shall be capable of being sounded independently of the alarm to the passenger spaces;
- (viii) the alarm devices shall be automatically silenced when a voice communication is transmitted over the public address system and shall also be arranged to automatically continue operation upon completion of the voice transmission;
- (ix) the control panel shall be located on the navigating bridge or in the main fire control station;
- (x) indicating units shall denote the section in which a detector or manual call point or circuit fault has operated or in the case of the addressable fire detection system the device that has been operated or location in which a fault has occurred; at least one unit shall be so located that it is easily accessible to responsible members of the crew at all times, when at sea or in port except when the ship is out of service;
- (xi) one indicating unit shall be located on the navigating bridge if the control panel is located in the main fire control station;
- (xii) clear information shall be displayed on or adjacent to each indicating unit about the spaces covered and the location of the sections;
- (xiii) no section of detectors installed on a zone circuit covering more than one deck within accommodation, service and control stations shall normally be permitted except a section which covers an enclosed stairway;

- (xiv) each loop circuit shall be divided into sections; each section shall be separated by a device which will ensure that if a short circuit or fault occurs anywhere within the loop only the affected section will be isolated from the rest of the circuit; no section between these devices shall include more than fifty (50) devices; a section of detectors which is installed in a loop circuit shall not be situated in more than one vertical fire zone; where more than one loop circuit is provided within a vertical fire zone they shall be so arranged that each deck level is not served by more than one circuit;
- (xv) in order to avoid delay in identifying the source of fire, the number of enclosed spaces included on each zone circuit shall be limited and in no case shall more than fifty enclosed spaces be permitted in any section;
- (xvi) in passenger ships, a section of detectors on a zone circuit shall not serve spaces on both sides of the ship nor on more than one deck and neither shall it be situated in more than one main vertical zone except that, if the protection of the ship against fire will not thereby be reduced, such a section of detectors may be permitted to serve both sides of the ship and more than one deck;
- (xvii) a section of fire detectors on a zone or loop circuit which covers a control station, a service space or an accommodation space shall not include a machinery space of Category 'A';
- (xviii) detectors shall be operated by heat, smoke or other products of combustion, flame, or any combination of these factors; detectors operated by other factors indicative of incipient fires may be considered provided that they are no less sensitive than such detectors; flame detectors shall only be used in addition to smoke or heat detectors;
- (xix) suitable instructions and components spares for testing and maintenance shall be provided; spare detector heads shall be carried in the proportion of not less than one for each 50 heads fitted in the installation with a minimum of six heads;
- (xx) the function of the detection system shall be periodically tested by means of equipment producing hot air at the appropriate temperature, or smoke or aerosol particles having the appropriate range of density or particle size, or other phenomena associated with incipient fires to which the detector is designed to respond; all detectors shall be of a type such that they can be tested for correct operation and restored to normal surveillance without the renewal of any component; and
- (xxi) the fire detection system shall not be used for any other purpose, except that closing of fire doors and similar functions at the fire control panel in accordance with the Fire Protection, Detection and Extinguishing Equipment Regulations;
- (xxii) where an addressable fire detection system has been provided with a feature to temporarily isolate a section from the monitoring system, due to repairs to the system or the vessel in the vicinity of the section, a visual flashing signal and an audible signal on a timed cycle of once every thirty (30) minutes shall be provided to alert the crew the system is isolated and to reactivate the section to a normal surveillance state upon the completion of the repairs;
- (xxiii) an addressable fire detection system shall be so designed that the first alarm will not prevent the initiating of any subsequent alarms;
- (xxiv) all arrangements are to be made to enable the initial configuration of the system to be restored in the event of failure.(electrical, electronic, informatic);

#### 21.6.3 Installation Requirements:

- (i) manual call points shall be installed throughout the accommodation and public spaces, service spaces and control stations; one manual call point shall be located at each exit; manual call points shall be readily accessible in the corridors of each deck such that no part of the corridor is more than 20 m from a manual call point;

- (ii) subject to paragraph 21.6.2 smoke detectors shall be installed in cabins, corridors, escape routes, stairways and service spaces; consideration shall be given to the installation of special purpose smoke detectors within ventilation ducting;
- (iii) heat detectors shall be installed in public rooms, galleys and pantries containing cooking appliances;
- (iv) where a fire detection and fire alarm system is required for the protection of spaces other than those specified in paragraph 21.6 (2) , at least one detector complying with sub-paragraph 21.6 (2) (xviii) shall be installed in each such space;
- (v) detectors shall be located for optimum performance; positions near beams and ventilation ducts or other positions where patterns of air flow could adversely affect performance and positions where impact or physical damage is likely shall be avoided; in general, detectors which are located on the overhead shall be a minimum distance of 0.5 m away from bulkheads;
- (vi) the standard maximum spacing of detectors is noted in the following table; where detectors are installed which exceed these spacings they shall be certificated by a certifying authority which confirms the detector safely covers the space specified and details of the detector's certification shall be submitted for inspection.

TYPE OF DETECTOR	MAX. FLOOR AREA PER DETECTOR	MAX. DISTANCE APART BETWEEN CENTRES	MAX. DISTANCE AWAY FROM BULKHEADS
Heat	37 m <sup>2</sup>	9 m	4.5 m
Smoke	74 m <sup>2</sup>	11 m	5.5 m

- (vii) electrical wiring which forms part of the system shall be so arranged as to avoid galleys, machinery spaces of Category 'A', and other enclosed spaces of high fire risk except where it is necessary to provide for fire detection or alarm in such spaces or to connect to the appropriate power supply; and

#### 21.6.4 System Design Requirements:

- (i) the system and equipment shall be suitably designed to withstand supply voltage variation and transients, ambient temperature changes, vibration, humidity, shock, impact and corrosion normally encountered in ships;
- (ii) smoke detectors required by sub-paragraph 21.6 (3) (ii) shall be certified to operate before the smoke density exceeds 12.5 per cent obscuration per metre, but not until the smoke density exceeds 2 per cent obscuration per metre; smoke detectors to be installed in other spaces shall operate with sensitivity limits having regard to the avoidance of detector insensitivity or oversensitivity;
- (iii) heat detectors shall be certified to operate before the temperature exceeds 78°C but not until the temperature exceeds 54°C, when the temperature is raised to these limits at a rate less than 1°C per minute; at higher rates of temperature rise, the heat detector shall operate within temperature limits having regard to the avoidance of detector insensitivity or oversensitivity; and
- (iv) in drying rooms and similar spaces of a normal high ambient temperature, the permissible temperature of operation of heat detectors may be increased to 30°C above the maximum deckhead temperature;
- (v) when detectors are provided with means to adjust their sensitivity, the arrangements are to be such that the set points can be fixed and readily identified.



- 21.7 Where arrangements are provided for fire doors to be held in the open position by means of energized electro-magnets, they shall be controlled from a central control point as required by the Hull Construction Regulations; they shall also be capable of release at each door; such devices shall be arranged to “fail-safe”, i.e., they shall cause the door to close in the event of their failure;
- (a) when the arrangements incorporate direct acting solenoids, they shall be capable of exerting a pull which equates to at least half the weight of the door, plus that force required to overcome any self-closing mechanism, thus being capable of holding the door open under a possible rolling condition of up to at least 15° either way; other retaining devices, e.g. solenoid controlled latches, shall be capable of exerting a restraint equivalent to the above; when de-energized, the residual magnetism shall not be so great as to impede the door from closing at inclinations of 3½° either way;
  - (b) the solenoid coils shall be rated for continuous operation;
  - (c) solenoids, when de-energized, shall release the doors from both the remote or local position and the solenoids must remain de-energized so that should the door thereafter be opened, it would not be retained in the open position;
  - (d) grouping of release circuits shall be so arranged that doors bounding, or lying in a main fire zone should normally be grouped together, and follow the same group nomenclature as the fire alarm indicators;
  - (e) local switches, and the group release switches at the main fire control station, shall be of the “on-off” type so that the solenoids remain de-energized when the switches are operated, until deliberately re-set after an emergency;
  - (f) a switch on each side of the door is to be preferred, but if only one switch is provided at each local door switching position, it shall be easily accessible and conspicuous to anyone passing through the door opening;
  - (g) an indication system which shows the “door open” and “door closed” condition shall be provided at the main control panel; and
  - (h) the device giving “door closed” indication shall only operate on the final movement of closing.

## 22. CONTROL AND INSTRUMENTATION

- 22.1 Each apparatus shall possess a degree of reliability in accordance with the importance of the control system of which it forms part.
- 22.2 The design of the control equipment shall be such that a failure in the control equipment will cause the least dangerous condition of the controlled process and such failure shall not render any reserve automatic or manual control or both inoperative.
- 22.3 Control and instrumentation circuits and their supply arrangements shall be so designed that failure of the power supply does not damage the installation nor endanger the ship.
- 22.4 The repeatability and accuracy of instruments and control equipment shall be adequate for their proposed use and shall be maintained at their specified value during their expected lifetime and normal operative use.
- 22.5 Electrical and electronic control equipment shall be suitable for the normal conditions encountered on shipboard.
- 22.6 (a) Control equipment shall be designed to operate satisfactorily in an air temperature range of 0° to 55°C and shall operate without deterioration in air temperature peaks of up to 70°C;
- (b) electrical equipment shall be designed and constructed to operate satisfactorily in locations where extreme ambient temperatures are likely to exist;
- (c) electrical equipment to be installed inside enclosures shall be designed to operate safely due to temperature increase caused by component heat dissipation, radiation from hot machinery surfaces or from the sun.
- 22.7 All control equipment shall operate satisfactorily under the following conditions of relative humidity:
- 95% r. h. at temperatures up to 45°C; and
  - 70% r. h. at all other relevant temperatures.
- 22.8 (a) Control equipment shall operate satisfactorily under the following vibration conditions:
- 2.0 - 13.2 Hz, displacement amplitude  $\pm 1.0$  mm;
  - 13.2 - 80.0 Hz, acceleration amplitude  $\pm 0.7$  g, maximum acceleration .7 g;
- (b) natural frequencies at supports for equipment and parts of equipment shall not lie within the 0 -80 Hz range, except that where they can not be kept outside this range by constructional design methods, the vibration shall be damped so that undue amplification is avoided.
- 22.9 Control equipment shall remain fully operational under each of the following inclinations and movements of the ship:
- inclination in all directions from the mounting position 22.5°;
- rolling 22.5°, 10 seconds full period; and
- linear vertical acceleration of  $\pm 1.0g$ .

- 22.10 (a) control equipment shall operate satisfactorily with the following variations from normal of the voltage and frequency of the ac power supplies to the equipment;

AC	PERMANENT VARIATION	TRANSIENT VARIATION	RECOVERY TIMESECONDS
Voltage	± 10%	± 20 %	3
Frequency	± 5%	± 10 %	3

- (b) ac supplied equipment shall be capable of ac maintaining functional stability and accuracy with input supplies having a possible harmonic content up to 5%;
- (c) for battery-supplied equipment, voltage variations of +30% and -25% as determined by the charging/discharging characteristics, shall be taken into account, including ripple voltage from the charging device; and
- (d) when the equipment is not connected to the battery during charging or when voltage stabilizing equipment is used, these values may be reduced to ± 20%.
- 22.11 Circuits shall be designed for easy test, calibration, maintenance and repair; repair shall preferably be effected by unit or card replacement.
- 22.12 The design of any circuit shall allow for variation in component data or drift within tolerances specified for the components.
- 22.13 The system design shall be such that there will be no undesirable mutual effect between the different circuits; a failure of one component in a circuit shall, as far as practicable, not cause failure of components in other circuits.
- 22.14 Design of circuits shall be such that there is no direct connection to any point of the ship's main power supply system, e.g. isolating transformers shall be used for power supplies; the chassis shall not form part of any circuit; extensive systems shall be sub-divided and the supplies individually protected; control circuits shall be separated from signalling and indicating circuits; faults in an indicating lamp circuit shall not impair the operation of the equipment or apparatus.
- 22.15 Circuits which depend on the maintenance of high insulation resistance for their accurate functioning shall not be used unless special precautions are taken to maintain the high insulation resistance; such circuits shall be provided with means to check the insulation resistance.
- 22.16 Signal levels of ship cables shall be kept high enough to overcome the effects of contact corrosion, hum and noise pick-up.
- 22.17 Transducers and amplifiers shall be situated as close to each other as is practicable; to avoid possible interference on control and instrumentation cables, signal cables shall be either screened or twisted pairs and there shall be sufficient separation between signal and other cables.
- 22.18 Programmable Logic Controllers (PLC's) shall comply with the following:
- (a) the program and data held in the system are to be protected from corruption by loss of power;
- (b) where any part of the program is stored in volatile memory a permanent copy of the program and the means to re-enter it are to be provided;
- (c) the quality control procedure governing software design, development, modification, replication, and installation are to be in accordance with the most recent version of an applicable rule or code issued by Society, Administration or a recognized Classification Society.

## 23. LIGHTNING CONDUCTORS

- 23.1 Lightning conductors shall be fitted to each mast of all wooden and composite ships and to each mast of steel or aluminum ships having wooden masts or topmasts except where the height of any antenna exceeds that of the masts and the antenna is equipped with lightning arresters or other effective devices.
- 23.2 Lightning conductors shall be made of continuous copper alloy tape or cable having a cross-sectional area not less than 25 mm<sup>2</sup> (#4 AWG) which shall be riveted with copper rivets or fastened with copper clamps to a suitable copper spike (air terminal) not less than 13 mm in diameter, projecting at least 150 mm above the top of the mast.
- 23.3 Where copper tape is used, its lower end shall terminate at the point at which the shrouds leave the mast and shall be securely clamped to a copper conductor not less than 13 mm in diameter.
- 23.4 The copper conductor shall be led down the shrouds and shall be securely clamped to a copper plate not less than 0.2 m<sup>2</sup> in area, fixed well below the light-load waterline and attached to the ship's side in such a manner that it is immersed under all conditions of heel and trim.
- 23.5 In wooden and composite ships fitted with steel masts, each mast shall be connected to a copper plate in accordance with subsection (4) and the copper rope or tape being securely attached to and in good electrical contact with the mast at or above the point at which the shrouds leave the mast.
- 23.6 Lightning conductors shall be run as straight as possible and sharp bends in the conductors shall be avoided; all clamps shall be of brass or copper, preferably of the serrated contact type, and shall be effectively locked.
- 23.7 The resistance of the lightning conductor, measured between the mast head and the position on the ground plate or hull to which the lightning conductor is grounded, shall not exceed 0.02 ohm.
- 23.8 Vessels in which tank vent outlets for flammable gases is located near, or at the top of a non conductive mast are to be protected by an air terminal at least 2m above the vent outlet; on a steel mast the steel mast must extend at least 2m above the vent outlet.

## 24. ELECTRIC PROPULSION PLANT

- 24.1 The requirements of this section relate to propulsion equipment and electromagnetic slip couplings essential for the safe operation of the vessel.
- 24.2 Where the arrangements permit a propulsion motor to be connected to a generating plant having a continuous rating greater than the motor rating, means shall be provided to limit the continuous input to the motor to a value not exceeding 5% overload in torque, based on the continuous full-load torque for which the motor is designed.
- 24.3 For the purpose of inspection and maintenance, provision shall be made for access to stator winding and armature coils and for the withdrawal and replacement of the coils of dc machines and of salient-pole ac machines.
- 24.4 Pressure or gravity lubrication systems shall be fitted with a low oil pressure alarm and shall be provided with an alternative means of lubrication as follows:
- (a) an automatically operated stand-by pump;
  - (b) an automatic gravity supply reservoir; or
  - (c) oil rings.
- 24.5 In excitation circuits there shall be no automatic circuit-opening devices except those affording short-circuit or phase-failure protection for the main propulsion circuit.
- 24.6 The torque available in the propulsion motors for manoeuvring shall be reasonably in excess of the trailing action of the propeller, to enable the latter to be stopped or reversed in a reasonable time when the vessel is travelling at maximum service speed.
- 24.7 For dc systems, arrangements for generator and motor excitation shall be such that, if the motor excitation circuit is opened by a switch or contactor, the generator excitation is simultaneously interrupted or the generator voltage is immediately reduced to zero.
- 24.8 Adequate torque margin shall be provided in ac propulsion systems to guard against the motor pulling out of synchronism under normal service conditions, including rough weather and on a multiple-screw vessel when turning.
- 24.9 Where the system might result in overspeeding of the propulsion motor in the event of loss of load, overspeed protection devices arranged to interrupt the supply of power shall be provided and the rotating parts shall be suitably constructed to prevent damage due to temporary overspeeding.
- 24.10 Effective means shall be provided in generators and motors to prevent the accumulation of moisture due to condensation such as heating the windings, either electrically or otherwise, when they are idle for appreciable periods.
- 24.11 All important circuits, instruments and apparatus shall be clearly labelled for identification.
- 24.12 Suitable interlocks shall be provided to prevent damage to the plant as a result of incorrect switching such as the opening of switches or contactors not intended to be operated while carrying current.
- 24.13 Where electric, pneumatic or hydraulic aid is used for normal operation, failure of such aid shall not result in interruption of power to the propeller shaft and any such device shall be capable of purely manual operation without delay.
- 24.14 Provision shall be made for protection against severe overloads, excess currents and electrical faults, likely to result in damage to the plant.
- 24.15 The protective equipment shall be capable of being so set as not to operate on the overloads or excess currents likely to be experienced in a heavy seaway or when manoeuvring.
- 24.16 The main propulsion circuit shall be provided with ground leakage indicating devices that will operate when the insulation resistance is 100,000 ohms or less.

- 24.17 Excitation circuits shall be provided with lamps, voltmeters or other suitable means to indicate continuously the state of the insulation of the excitation circuits under running conditions.
- 24.18 For dc equipment operating at voltages exceeding 500 volts and for all ac equipment, both audible and visual ground alarms shall be fitted:
- (a) the alarms shall operate automatically on the occurrence of a ground fault but the operation of such devices shall not interrupt the power supply;
  - (b) a switch may be provided for switching off the audible device but in such cases the visual alarm shall remain switched on until the fault has been cleared; and
  - (c) where a ground connection is used for the operation of the indicator, the arrangement shall be such that the ground circuit is opened automatically in order to stop the circulation of fault current.
- 24.19 Access doors for switchgear and control gear operating at voltages in excess of **50 volts** shall be either interlocked to prevent access while such parts are alive or be provided with a lock, the key of which shall be kept in a place accessible only to authorized personnel.
- 24.20 For the protection of the field windings and cables, means shall be provided for limiting the voltage induced when the field circuits are opened.
- 24.21 Where excitation is obtained direct from the auxiliary bus-bars, means shall be provided to limit the voltage induced at the bus-bars when the auxiliary generator circuit breaker or the distribution circuit breaker opens.
- 24.22 Shunt resistors which are connected across the field circuit of synchronous propulsion motors when they are functioning as a synchronous motor shall be suitably insulated for the voltage induced when manoeuvring and shall be amply rated.
- 24.23 Where separately driven direct-current generators are connected electrically in series, means shall be provided to prevent reversal of the direction of rotation of any of them on the failure of the driving power of the prime mover.
- 24.24 Contactors and switches used for reversing the rotation of the propulsion motors shall be provided with means for opening them forcibly if they should inadvertently be left closed and they shall be so interlocked mechanically as to prevent the circuits for ahead and astern rotation being closed simultaneously.
- 24.25 An audible alarm device shall be provided for machines having enclosed-ventilating systems, arranged to operate in the event of the temperature of the heated air exceeding the predetermined safe value.
- 24.26 Electric slip couplings shall be of substantial and rigid construction, and shall be enclosed, ventilated or otherwise provided with substantial wire or mesh screen to prevent injury to personnel or the entry of foreign material.
- 24.27 Electric slip couplings, including their exciters when tested under rated load conditions shall have temperature rises not exceeding the limits given in Table 16-1 of Section 16.
- 24.28 When the coupling is fitted with an integral fan, the temperature-rise limits given above shall not be exceeded when operating continuously at 70% full load speed, rated torque and rated full-load excitation.
- 24.29 Shafting materials for motors and generators above 375 kW which are essential to the safety of the ship shall be submitted in accordance with Schedule VI Part II Div. II of the Marine Machinery Regulations

- 24.30 Electronic governors controlling the speed of a propulsion unit shall have two power supplies, one of which shall be a battery; in the event of a “normal” supply failure the governor shall be automatically transferred to the alternative battery power supply; an audible and/or visual alarm shall be provided in the main machinery control area to indicate that the governor has transferred to the battery supply; the prime-mover shall be equipped with a separate overspeed device to prevent runaway if a failure should render the governor inoperative; the alternative battery supply shall be arranged for trickle charge to ensure the battery is always in a fully charged state; each governor shall be protected separately so that a failure in one governor will not cause failure in other governors; a mechanical back-up governor may be provided in lieu of the alternative battery supply; the mechanical governor shall be of a suitable type and shall automatically assume control of the engine in the event of electronic governor failure.
- 24.31 Alternating-current propulsion generators shall be provided with means for obtaining the temperatures of the stationary windings; a minimum of one embedded temperature detector per phase is to be provided for this purpose on the hot end of the machine; the temperatures are to be indicated at a convenient location, preferably the generator control panel.

## 25. ADDITIONAL REQUIREMENTS FOR AC SUPPLY SYSTEMS WITH VOLTAGES OF 1 KV AND ABOVE

NOTE: FOR THE PURPOSES OF THIS SECTION, "HIGH VOLTAGE" MEANS VOLTAGES OF 1 kV AND ABOVE

- 25.1 The main switchboard shall be in at least two independent sections, each supplied by at least one generator and so arranged that duplicated essential services are supplied from separate switchboard sections.
- 25.2 Distribution systems shall be three-phase, 3-wire and may be operated with the neutral either insulated or grounded.
- 25.3 Where the system neutral is insulated, the dielectric strength of all electrical equipment is to be sufficient to withstand any possible transient over-voltage to ground.
- 25.4 Where the system neutral is grounded, the connection to ground shall be made through a resistor which is capable of limiting ground fault current to a value not greater than the full load current of the largest connected generator and not less than 3 times the minimum current required to operate any ground-fault monitoring or protection device; the neutral impedance shall be chosen so that the transient over voltages caused by a fault are kept to a minimum.
- 25.5 A neutral grounding resistor shall be provided for each section of the system that can operate independently.
- 25.6 A disconnecting means shall be fitted in each generator ground connection to permit complete isolation of the generator for maintenance purposes.
- 25.7 Transformer primary neutrals shall not be grounded except when all generators are disconnected and power is being supplied from shore.
- 25.8 A means of visually and audibly indicating any system ground fault shall be fitted.
- 25.9 A suitable disconnecting means shall be provided on the supply side of fuses used for the protection of instrument potential transformers.
- 25.10 Terminal boxes and cable termination spaces shall be of sufficient size to accommodate cable glands and terminations while maintaining minimum cable bending radii.
- 25.11 High voltage and low voltage cable connections shall not be accommodated in the same terminal box.
- 25.12 Where practicable, all high voltage cable connections shall be covered with a suitable insulating material, otherwise, phases are to be separated from ground and from each other by barriers of suitable insulating material.
- 25.13 High voltage equipment shall be so constructed and located that live parts are inaccessible to unauthorized persons.
- 25.14 Permanent legible warning notices shall be attached to high voltage equipment and at the entrances to compartments where high voltage equipment is housed; such notices shall carry the wording "DANGER HIGH VOLTAGE" and "DANGER HAUT TENSION".
- 25.15 Where a transformer is located in a compartment which forms the enclosure of the transformer, the door of the compartment shall be provided with a means to prohibit unauthorized access and interlocked with the transformer primary circuit breaker so that the circuit breaker is tripped when the door is opened and cannot be closed while the door is open.
- 25.16 Compartments housing high voltage equipment and work areas surrounding the equipment shall be adequately illuminated and provided with a means of exit which shall be kept clear of all obstructions.
- 25.17 High voltage cables shall not be run in the same wireway as cables for use in systems operating at voltages less than 1 kV.



- 25.18 High voltage cables shall be readily identifiable and shall be clearly marked at each side of all bulkhead or deck penetrations with the wording “DANGER HIGH VOLTAGE” and “DANGER HAUT TENSION”.
- 25.19 High voltage cables shall not be installed in elevator shafts and where practicable, shall not be run through accommodation spaces.
- 25.20 Where single conductor cables are used, precautions shall be taken to prevent the flow of induced circulating currents in the sheath or armour and the cables shall be transposed at intervals of approximately 16 metres.
- 25.21 For switchgear assemblies 1 kV and over, the most recent edition of CSA Standard C.22.2 No. 31, shall be used as criteria for construction, installation and testing.
- 25.22 High voltage cables associated with systems operating at 2 kV and above are to be terminated in accordance with the most recent edition of Canadian Electrical Code Part 1.
- 25.23 For control apparatus, the most recent edition of CSA Standard C22.2 No. 14, shall be used as criteria for construction, installation and testing.
- 25.24 For transformers, the most recent edition of CSA Standard C9, shall be used as criteria for construction, installation and testing.

## 26. HAZARDOUS LOCATIONS

- 26.1 This section applies to electrical equipment and installations in hazardous locations as defined in the Canadian Electrical Code (C. E. C.) Part I, C 22.1-98; every electrical installation in a hazardous location shall comply with either Section 18, or Annex J 18 of Appendix J of the C. E. C., except as modified in TP 127 Section 26. It is recommended that in all new vessel construction the electrical installations in hazardous locations be in accordance to C. E. C. Section 18 for Class 1, Zones 0, 1 and Zone 2; existing installations which employ the Division system for Class 1 locations shall be permitted continued use of the Division system provided the installations comply with Annex J 18 of Appendix J of C .E. C. It shall be noted from Table 26-1 that equipment permitted in Zone 2 is also permitted for installation in a Class I Div. 2 location.
- 26.2 Electrical equipment which is intended to be installed in areas that are classed as hazardous locations shall be certified safe and listed by a certifying authority for the particular atmosphere or location in which the equipment is to be installed; in addition the exposed surface temperature of the electrical equipment shall not operate in excess of the ignition temperature of the explosive atmosphere which may exist in the hazardous area.
- 26.3 Distribution systems with grounded neutral or grounded phases shall not be used in hazardous locations; distribution systems with hull return shall not be used, but this does not preclude the installation of:
- (a) impressed current cathodic protective systems;
  - (b) insulation level monitoring devices provided the circulation current does not exceed 30 milliamperes under the most unfavourable conditions.
  - (c) limited and locally grounded systems, such as starting and ignition systems of internal combustion engines, provided that any possible resulting current does not flow directly through the hazardous location.
- 26.4 The Class I hazardous locations comparison chart between the Zone method of equipment protection and the Division system are found in Table 26-1.

**TABLE 26-1**

Class I Certified Equipment Comparison Chart

ZONE SYSTEM		DIVISION SYSTEM	
Intrinsically safe, i, ia	Zone 0		
All Equipment acceptable in Zone 0 Flameproof d Pressurized p Increased safety e intrinsically safe ib encapsulation m	Zone 1	Division 1	Class I Div. 1 Equipment intrinsically safe i, ia
Equipment acceptable for Zone 0  Equipment acceptable for Zone 1 and Class I Div. 2 Non sparking n	Zone 2	Division 2	Equipment Acceptable for Class I Div. 1 and Div. II + Flameproof d Pressurized p Intrinsically safe ib Increased safety e Non-sparking n Encapsulation

- 26.5 Where a subsection states that an electrical system is to be intrinsically safe, the system shall be certified as intrinsically safe for use in a hazardous location;
- (a) each electric cable for an intrinsically safe system must:
    - (i) be 50 mm or more from cable of non-intrinsically safe circuits;
    - (ii) be partitioned by a grounded metal barrier from other non intrinsically safe electric cables; or
    - (iii) be a shielded cable;
  - (b) installation instructions and restrictions on the system shall be submitted to the Board for inspection; typical restrictions that must be specified include:
    - (i) voltage limitations;
    - (ii) allowable cable parameters recommended by the manufacturer;
    - (iii) maximum length of cable recommended by the manufacturer; and
    - (iv) ability of system to accept passive devices.
  - (c) intrinsically safe systems must not be interconnected unless the systems were certified safe with the particular arrangement; and
  - (d) the deck wiring diagram required by section 36 shall specify:
    - (i) system identification as to manufacturer's model number;
    - (ii) system use;
    - (iii) cable parameter including length and type of cable;

- (iv) wiring and equipment locations; and
  - (v) installation details.
- 26.6 Purged and pressured equipment shall meet the requirements of CSA Standard CAN/CSA-E79-2, the National Fire Protection Association No. 496 or IEC Publication 79-2.
- 26.7 Electrical equipment installations in a Class I Zone 0 hazardous location shall be in accordance with the following:
- (a) only electrical equipment certified intrinsically safe “i” or “ia” shall be permitted in a Zone 0 hazardous location; intrinsically safe circuits in accordance with Section 26.2;
  - (b) seals are required where:
    - (i) rigid conduit leaves a Class I Zone 0 hazardous location; except that where a conduit passes through a hazardous zone and which no fitting or piece of equipment is installed in the run, a seal is not required provided the run extends 300 mm beyond the bulkhead of the hazardous location and the location is a non hazardous zone; and
    - (ii) at first point of termination of a continuous sheathed cable.
  - (c) cable for use in an intrinsically safe system must meet:
    - (i) the requirements of section 12 and subsection 26.5 of this section; and
    - (ii) the recommendations of ISA RP 12.6 issued by The Instrument Society of America for “Installation of Intrinsically Safe Instrument Systems in Class I Hazardous Locations”, except Appendix A.1;
- 26.8 Electrical equipment installation in a Class I, Zone 1 or Division 1 hazardous location shall be in accordance with Section 26.2 and as providing one or more of the protective methods listed in Table 26-1 for a Zone 1 area:
- (a) cable for Class I Zone 1 hazardous location must:
    - (i) be braided armoured marine cable constructed in accordance with section 12 of this standard or MI type cable; or
    - (ii) be unarmoured marine cable installed in threaded rigid metal conduit; or
    - (iii) RW90 Cross-linked polyethylene or ethylene propylene rubber insulated cable rated -40°C installed in threaded rigid metal conduit.
  - (b) flexible cords and cables must be C.S.A. certified for extra hard usage;
  - (c) wiring methods shall be of threaded metal rigid conduit and fittings or cables approved for Class I hazardous locations, with associated seals or cable glands that comply with subsection 26.2.
- 26.9 Electrical equipment installation in a Class I, Zone 2 or Division 2 hazardous location shall be in accordance with Section 26.2 and as providing one or more of the protective methods listed in Table 26-1 for a Zone 2 area:
- (a) cable installed in a Class I Zone 2 or Division 2 shall be approved marine cable protected from mechanical damage or in accordance with subsection 26.8 (a) (iii).
  - (b) wiring methods shall be of threaded rigid metal conduit or cables approved for hazardous locations, with associated seals or cable glands that comply with subsection 26.2.
- 26.10 Electrical equipment installation in a Class II and III hazardous locations shall be certified safe in accordance with Section 26.2:
- (a) cable for Class II and III shall be in accordance with subsection 26.9 (a); and meet the requirements of section 12;
  - (b) wiring methods shall be of threaded rigid metal conduit or marine cables;

- (c) sealing shall be of cable glands certified safe in accordance with section 26.2.
- 26.11 Switches shall be certified safe for hazardous locations and each switch controlling electrical equipment in hazardous locations must have a pole for each circuit conductor.
- 26.12 Fans located in a hazardous location shall be so designed as to render sparking impossible in the event of the impeller tips touching the fan casing.
- 26.13 Each electric motor for a fan that ventilates a hazardous location must be certified safe for the same class, zone, division and group, as the ventilated location, or be:
  - (a) outside the ventilation duct;
  - (b) 3 m from the ventilation duct termination; and
  - (c) in a non-hazardous location.
- 26.14 Equipment mounted in a ventilation duct that ventilates a hazardous location shall meet the classification requirements of that space.
- 26.15 Each pulley drive in a hazardous location must have:
  - (a) a conductive belt, i.e. anti-static; and
  - (b) pulleys, shafts and driving equipment grounded to meet the National Fire Protection Association, No. 77.
- 26.16 Each vessel that carries combustible liquid cargo with a closed-cup flashpoint of 60 degrees C, or higher must have:
  - (a) electrical equipment located in cargo tanks certified safe for a Class I Zone 0 location; and
  - (b) no storage battery in any cargo handling room.
- 26.17 Each vessel that carries combustible or flammable cargo with a closed-cup flashpoint lower than 60 degrees C or liquid sulphur cargo, or a tankship that carries inorganic acid cargo shall meet the requirements of this subsection except:
  - (a) a vessel carrying bulk liquefied flammable gases as a cargo, cargo residue or vapour must meet the requirements of subsection 26.18;
  - (b) a vessel carrying carbon disulphide must have only Zone 0 electric equipment in the locations listed in paragraphs (f) through (m) of this subsection;
  - (c) electric cable must be as close as practicable to the centerline and must be away from cargo tank openings;
  - (d) an enclosed hazardous location that has certified safe lighting fixtures must:
    - (i) have at least two lighting branch circuits;
    - (ii) be arranged so that there is light for re-lamping any de-energized lighting circuits; and
    - (iii) not have the switch within the space for those spaces containing lighting fixtures under paragraphs (h), (j) and (k) of this subsection.
  - (e) if a submerged cargo pump motor is in a cargo tank:
    - (i) low liquid level, motor current or pump discharge pressure must automatically shutdown power to the motor if the pump loses suction;
    - (ii) an audible and visual alarm located at the cargo control station must be actuated by the shutdown of the motor; and
    - (iii) there must be a lockable circuit breaker or lockable switch that disconnects power to the motor;
  - (f) a cargo tank must not contain any electric equipment except:
    - (i) electrical equipment certified safe for a Class I Zone 0 location; and

- (ii) submerged cargo pumps, and
- (iii) supply cable for submerged cargo pumps;
- (g) a cargo handling room must not have any electric cable or other electric equipment, except:
  - (i) electrical equipment certified safe for a Class I Zone 1 and Class 1 Division 1 location; and
  - (ii) only cables in which are supplying the necessary operational equipment permitted in item g (i);
- (h) lighting for cargo handling room except a cargo handling room under paragraph (i) of this subsection, must be lighted through fixed-glass lenses in the bulkhead or overhead; each fixed-glass lens must be wire-inserted glass that is at least 6 mm thick and arranged to maintain the watertight and gastight integrity of the structure; the fixed-glass lens may form a part of a lighting fixture if the following are met:
  - (i) there is no access to the interior of the fixture from the cargo handling room;
  - (ii) the fixture is vented to a non-hazardous location;
  - (iii) the fixture is wired from outside the cargo handling room; and
  - (iv) the temperature on the cargo handling room surface of the glass lens, based on an ambient temperature of 40 degrees C, is not higher than 180 degrees C.
- (i) a cargo handling room which precludes the lighting arrangement of paragraph (h) of this subsection, or where the lighting arrangement of paragraph (h) of this subsection does not give the required light, must have certified safe electrical equipment in accordance with item g (i);
- (j) an enclosed space that is immediately above, below or next to a cargo tank must not contain any electric equipment except equipment allowed for cargo handling rooms in paragraphs (g) and (h), and
  - (i) through runs of cable in accordance with subsection 26.8; and
  - (ii) watertight enclosures with bolted and gasketed covers containing only:
    - (1) depth sounding devices;
    - (2) log devices; and
    - (3) impressed-current cathodic protection system electrodes;
- (k) a cargo hose stowage space must not have any electric equipment except as noted in items g (i) (ii) and through runs of cable in accordance with subsection 26.8; and
- (l) a space that has cargo piping must not have any electrical equipment except equipment in accordance with items g (i) (ii) and through runs of cable in accordance with subsection 26.8; and
- (m) a location in the weather except on a tank vessel carrying inorganic acid must have equipment in accordance with items g (i) (ii) and through runs of cable in accordance with subsection 26.8;
  - (i) within 3 m of:
    - (1) A cargo tank ullage opening;
    - (2) A cargo pipe flange;
    - (3) A cargo valve;
    - (4) A cargo handling room entrance;
    - (5) A cargo handling room ventilation opening; or
    - (6) A spill cargo containment save-all for loading or unloading;
  - (ii) within 5 m of cargo tank pressure/vacuum valves and a vertical zone of unlimited height;

- (iii) within 10 m of cargo tank vent outlets and a vertical zone of unlimited height;
- (iv) on the open deck over the cargo area to the full width of the vessel, plus 3 m fore and aft on the open deck, up to a height of 2.4 m above the deck.
- (n) except for those spaces listed in paragraphs (f) through (i), a space that has a direct opening to any space listed in paragraphs (f) through (m) must have electric equipment and installations certified safe as the hazardous location to which it opens.
- (o) distribution systems, except intrinsically safe circuits, feeding or passing through a hazardous location referred to in this sub-section shall have a device capable of continuously monitoring the insulation level to ground and giving an audible alarm at a manned position when ground current exceeds 30 milliamperes.

**Typical Hazardous Area Referred to in Clause 26.17 (m) of Section 26**

**Plan View of Open Deck**

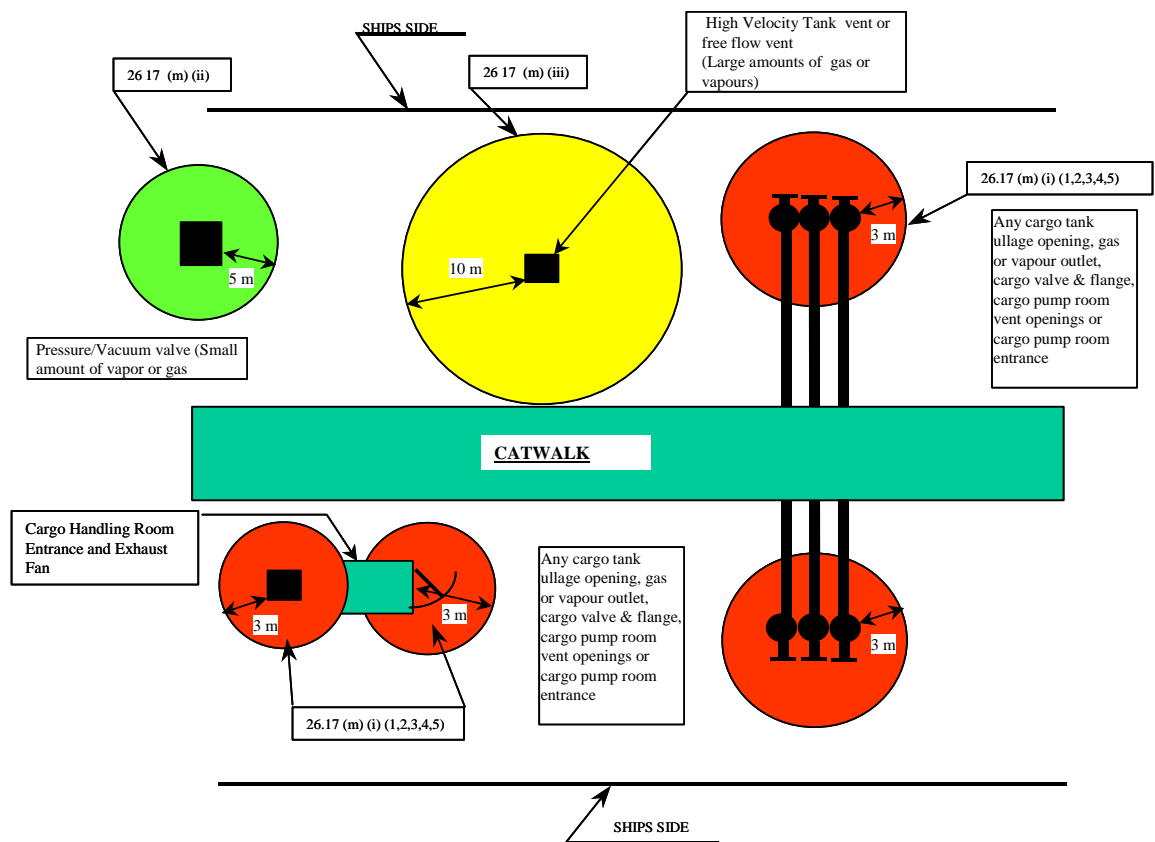

**Typical Hazardous Area Referred to in Clause 26.17 (m) of Section 26**

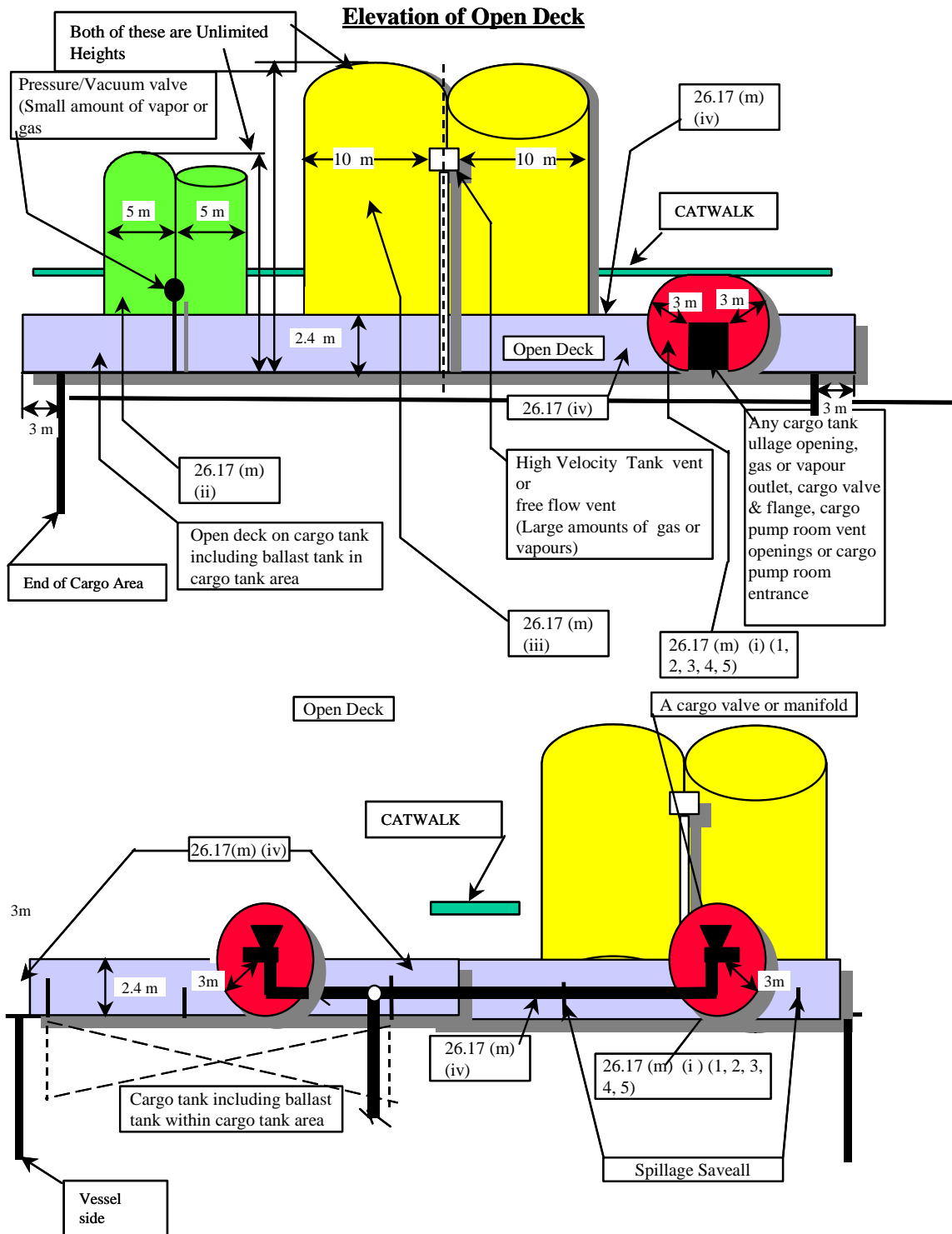

**Section Through Cargo Tank and Deck**



- (p) Any semi-enclosed space that contains a condition described in item (m), must only have electrical equipment certified safe for Class I, Zone 2 or Division II fitted outside the limits described in (m).
  - (q) Equipment in enclosed spaces, other than Category A machinery spaces, having access from open deck areas in item (m) need not be of a certified safe type provided the access is through a double door air lock. Arrangements for an air lock should include:
    - (i) two gas tight steel doors of self-closing type with no hold back arrangement spaced at least 1.5m, but not more than 2.5m apart.
    - (ii) The non-hazardous space and the air lock are to be maintained at overpressure relative to the external hazardous area by independent mechanical ventilation systems arranged such that a single failure will not result in the simultaneous loss of overpressure in both the non-hazardous space and the air lock.
    - (iii) failure of either ventilation system described in item (ii) must be alarmed at a normally manned control station.
    - (iv) Notices, warning that the doors are to be kept closed must be fitted.
    - (v) Following shutdown of the ventilation systems described in (ii), all electrical equipment in the space that is not certified safe, must remain de-energized until the space is determined to be gas free or has been sufficiently purged to assure the space is gas free, and the ventilation overpressure restored, prior to energization of this equipment.
- 26.18 Each vessel that carries bulk liquefied flammable gases or ammonia as a cargo, cargo residue or vapour must meet the requirements of this subsection:
- (a) as used in this subsection:
    - (i) the terms “gas-safe” and “gas-dangerous” spaces are found in the Interpretation section of this standard
    - (ii) the term “gas-dangerous” does not include the weather deck of an ammonia carrier;
  - (b) each submerged cargo pump motor installation must be inspected by the Board:
  - (c) electrical equipment, must not be installed in a gas-dangerous space or zone, except:
    - (i) intrinsically safe “i” and “ia” electrical equipment and wiring, and
    - (ii) other equipment as allowed in this subsection;
  - (d) a submerged cargo pump motor, if installed in a tank, must meet the following requirements:
    - (i) low liquid level, motor current or pump discharge pressure must automatically shut down power to the pump motor if the pump loses suction;
    - (ii) there must be an audible and visual alarm at the cargo-control station that activates if the motor shuts down under the requirements of subparagraph (i) of this paragraph; and
    - (iii) there must be a lockable circuit breaker or lockable switch that disconnects the power to the motor;
  - (e) electrical equipment must not be installed in a hold space that has a tank that is not required to have a secondary barrier except:
    - (i) through runs of cable in accordance with subsection 26.8; and
    - (ii) lighting fixtures suitable for a Class 1 Zone 1 or Div. 1 location;
    - (iii) depth sounding devices in gastight enclosures;
    - (iv) log devices in gastight enclosures;

- (v) impressed current cathodic protection system electrodes in gastight enclosures; and
  - (vi) braided armoured marine cable or MI type cable for a submerged cargo pump motor;
- (f) electrical equipment must not be installed in a space that is separated by a gastight steel boundary from a hold space that has a tank that must have a secondary barrier except:
- (i) through runs of cable in accordance with subsection 26.8; and
  - (ii) lighting fixtures suitable for a Class 1 Zone 1 or Div. 1 location;
  - (iii) depth sounding devices in gastight enclosures;
  - (iv) log devices in gastight enclosures;
  - (v) impressed current cathodic protection system electrodes in gastight enclosures;
  - (vi) braided armoured marine cable or MI type cable for submerged cargo pump motor;
- (g) a cargo-handling room must not have any electrical equipment installed other than equipment or lighting fixtures certified safe for the location in accordance with Section 26.17 (g) (i);
- (h) a space for cargo hose storage or a space that has cargo piping must not have any installed electrical equipment, except:
- (i) lighting fixtures in accordance with Section 26.17 (g) (i);
  - (ii) through runs of cable in accordance with subsection 26.8;
- (i) a gas-dangerous zone on the open deck must not have any installed electrical equipment, except:
- (i) certified safe electrical equipment suitable for a Class 1 Zone 1 or Div. 1 location that is necessary for the operation of vessel;
  - (ii) through runs of cable in accordance with subsection 26.8;
- (j) a space, except those named in paragraphs (e) through (h) of this subsection that has a direct opening to gas-dangerous spaces or zones must have no electrical equipment except as allowed in the gas-dangerous space or zone;
- (k) each gas-dangerous space that has lighting fixtures must have at least two branch circuits for lighting;
- (l) each switch and each overcurrent protective device for any lighting circuit that is in a gas-dangerous space must open all conductors of the circuit simultaneously;
- (m) each switch and each overcurrent protective device for lighting in a gas-dangerous space must be in a gas-safe space; and
- (n) distribution systems, except intrinsically safe “i” and “ia” circuits, feeding or passing through a hazardous location referred to in this subsection shall have a device capable of continuously monitoring the insulation level to ground and giving an audible alarm at a manned position when ground current exceeds 30 milliamperes.
- 26.19 If the voltage of a distribution system on a tank vessel is 1000 volts or more, line to line, and the distribution system is grounded, any resulting current must not flow through hazardous location. Distribution systems on tank vessels of less than 1000 volts, line to line, shall not be grounded subject to Section 26.3.
- 26.20 Vessels which may carry coal
- 26.20.1 Electrical cables and equipment installed in cargo holds shall be limited to that which is necessary for the operational activities during loading, transporting and unloading the coal cargo. The electrical equipment necessary to be installed in the cargo hold shall be certified safe for a Class II Div. 1 Group F location and the equipment in these spaces shall be electrically isolated while the space is not open to the atmosphere for ventilation.

- 26.20.1 Electrical cables and equipment installed in cargo holds shall be limited to that which is necessary for the operational activities during loading, transporting and unloading the coal cargo. The electrical equipment necessary to be installed in these areas shall be certified safe for Class II Div. 1 Group F locations and means provided for positive isolation of the electrical equipment located in these spaces.
- 26.20.2 In the unloading tunnels, cargo transfer areas and adjacent spaces of self-unloaders the electrical equipment shall be certified safe for not less than a Class II Div. 2 Group F locations which are to be continuously ventilated by mechanical means. The spaces shall be regularly monitored for the presence of methane gas; an audible and visual alarm shall be provided at the main machinery control station to indicate any failure of the tunnel and adjacent spaces ventilation system and a means provided to isolate the Class II Division 2 equipment in the event of ventilation failure.
- 26.20.3 Electrical equipment located in the tunnel and adjacent spaces necessary in the event of an emergency shall be certified safe for a Class I, Zone 2 Group II A or Class I Division 2 Group D locations.
- 26.20.4 The hazardous locations on the open deck shall extend in a 3 meter radius around the ventilation outlets of the tunnel and adjacent spaces.
- 26.20.5 Where necessary, electrical cables installed in cargo holds or bins shall be in accordance with section 26.5 or 26.9 (a); those cables located in the unloading tunnels, cargo transfer areas or adjacent spaces may be unarmoured marine cable constructed in accordance with section 12 which shall be suitably protected against mechanical damage; cables seals, terminations or glands shall be applicable to the hazardous requirements in accordance with section 26.2.
- 26.20.6 Electrical equipment certificated for Class I locations may exceed those temperatures permitted for installation in a Class II location, therefore care should be taken to ensure that Class I equipment is also certificated for Class II locations.

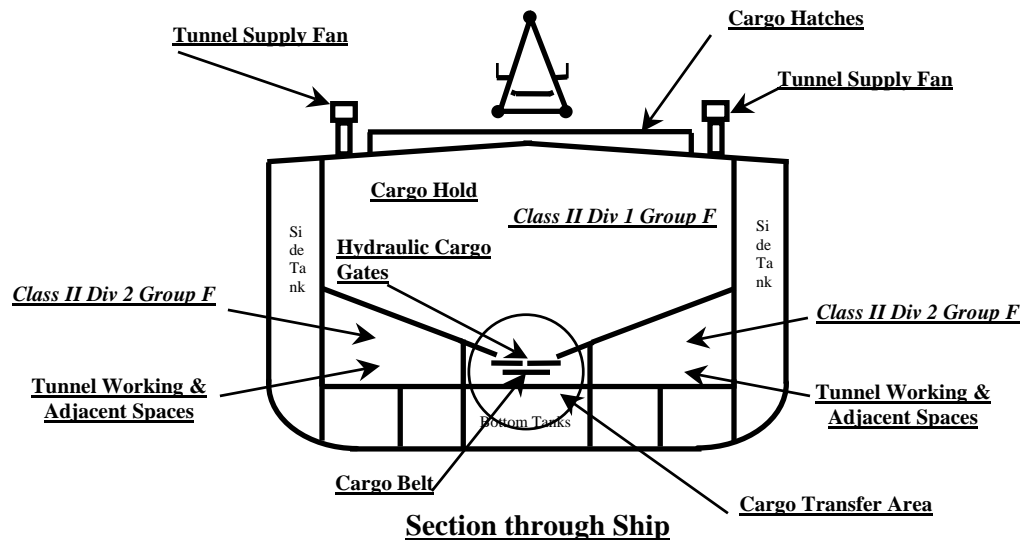

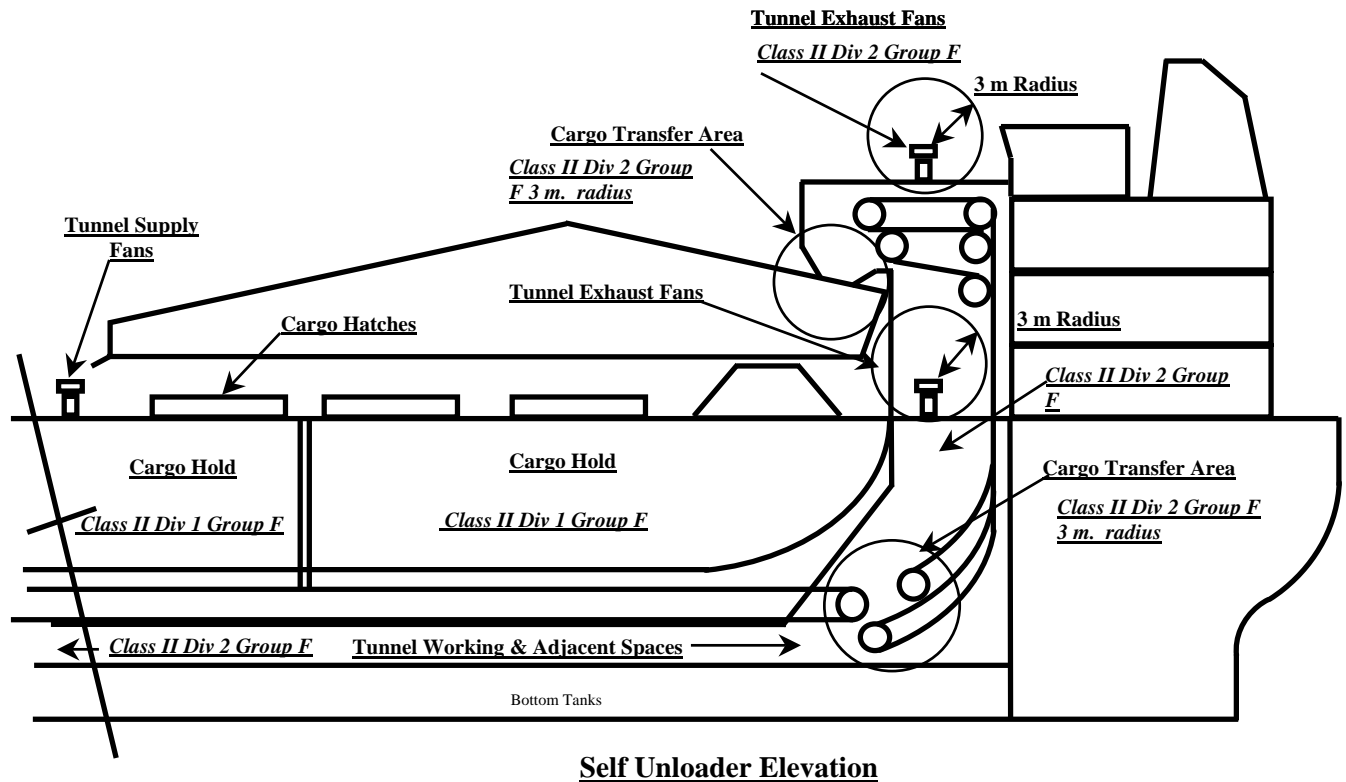

- 26.21 Each electrical installation where a flammable anaesthetic is used or stored shall meet the requirements of the Canadian Electrical Code, Part I, Section 24.
- 26.22 Passenger ships with special category spaces:
- (a) in special category spaces above the bulkhead deck electrical equipment and wiring shall be installed at least 45 cm above the uppermost deck within the space unless the electrical equipment and wiring are necessary below this level for the safe operation of the ship, in which case the electrical equipment and wiring shall be a type certified safe for Class I, Division 2, Group D or Zone 2 Group II A locations; electrical equipment installed at more than 45 cm above the deck shall be of a type so enclosed and protected as to prevent the escape of sparks; the reference to a level of 45 cm above the uppermost deck means that the hazardous area extends from 45 cm above the uppermost fixed or portable deck to the deck below; electrical equipment and wiring, if installed in an exhaust ventilation duct, shall be of a type certified safe for Class I, Division 2, Group D or Zone 2 Group II A hazardous locations;
  - (b) in special category spaces below the bulkhead deck and in cargo spaces containing motor vehicles with fuel in their tanks for their own propulsion, electrical equipment and wiring shall be certified safe for Class I, Division 2, Group D; electrical equipment and wiring, if installed in an exhaust ventilation duct, shall be of a type certified safe for Class I, Division 2, Group D or Zone 2 Group II A hazardous locations; and
  - (c) loss of ventilation in any special category space shall actuate an audible and visual alarm on the bridge or at a position that will always be manned while vehicles with fuel in their tanks are onboard.

- 26.23 Closed Ro-Ro spaces in cargo vessels carrying motor vehicles with fuel in their tanks for their own propulsion shall comply with the following provisions:
- (a) except as provided in 26.22 (b) electrical equipment and wiring shall be of a type suitable for use in a Class 1, Division 2, Group D or Zone 2 Group II A hazardous location;
  - (b) above a height of 450 mm from the deck and from each platform for vehicles, if fitted, except platforms with openings of sufficient size permitting penetration of gasoline vapours downwards, electrical equipment of a type so enclosed and protected as to prevent the escape of sparks shall be permitted as an alternative on condition that the ventilating system is so designed and operated as to provide continuous ventilation of the cargo spaces at the rate of at least ten air changes per hour whenever vehicles are on board;
  - (c) other equipment which may constitute a source of ignition of flammable vapours shall not be permitted;
  - (d) electrical equipment and wiring in the exhaust ventilation duct shall be of a type certified safe for use in a Class 1, Division 2, Group D or Zone 2 Group II A hazardous location and the outlet from any exhaust duct shall be sited in a safe position, having regard to other possible source of ignition; and
  - (e) scuppers shall not be led to machinery or other spaces where sources of ignition may be present.
- 26.24 The electrical installation in battery compartments shall comply with Section 19; electrical equipment installed in battery compartments where vented batteries are employed shall be certified safe for a Class I Division 1 Group B location, or a method of protection equal to Zone 1 Group IIC **refer to subsection 26.1**; compartments where sealed (valve regulated) batteries are used exclusively the electrical equipment shall be in accordance with Section 19.5.10.
- 26.25 A space for the stowage or mixing of paint shall not have any electric equipment, except:
- (a) electric equipment certified safe for a Class I, Division 1, Group D location or, equipment provided with a method of protection equal to Zone 1 Group IIA; and
  - (b) through runs of armoured marine cable or MI type cable.
- 26.26 Distribution systems supplying essential services or emergency power shall be so arranged to avoid hazardous locations where practicable.
- 26.27 Helicopter hangar electrical equipment installations are to comply with TP-4414 "Guidelines Respecting Helicopter Facilities on Ships".

## 27. TESTING & INSPECTION AT MANUFACTURER'S PLANT

- 27.1 Subject to subsection 27.2, tests for following electrical equipment shall be witnessed by a marine surveyor at the manufacturer's plant, except that a recognized Classification Society Certificate shall serve as test verification of such inspection for equipment manufactured outside of Canada:
- (a) ship's service and emergency generators, 100 kW and over;
  - (b) propulsion generators, motors and excitation sets;
  - (c) electric motors for essential services, 100 kW and over;
  - (d) main switchboards with an aggregate connected load of 25kW and above;
  - (e) motor control centres having a capacity of 100 kW and over;
  - (f) propulsion control switchboards;
  - (g) main propulsion cables;
  - (h) power and lighting transformers, 10 kVA and over;
  - (i) all static power supplies for emergency use; and
  - (j) all static power supplies 50 kW and over;
  - (k) all emergency switchboards.
- 27.2 In the case of duplicate machines, or transformers, other than propulsion machines or propulsion transformers, type tests of temperature rise and commutation taken on a prototype machine satisfy the requirements for individual testing provided they are in conjunction with a running test, high potential and insulation resistance tests.
- 27.3 Machines and equipment having a capacity less than that set forth in subsection (1), shall be tested by the manufacturer whose certificate of test shall be made available, if requested, to the marine surveyor.
- 27.4 In the case of propulsion machines operating at more than one voltage or one frequency, the predominant operating criteria shall be used as the basis for testing the machine.

## 28. TESTING ROTATING MACHINES

- 28.1 The tests which shall be carried out on the rotating machines described in Section 27 are:
- (a) temperature-rise test;
  - (b) insulation resistance test;
  - (c) high potential test;
  - (d) overload test; and
  - (e) commutation test.
- 28.2 After the machines have been run continuously under full load until steady final temperatures have been reached, the temperature rises shall not exceed those given in Table 16-1,16-2 and 16-3 in Section 16.
- 28.3 The insulation resistance test of generator and motor windings shall be carried out with the machine at operating temperature and should be not less than one megohm.
- 28.4 The high potential test of ac generators shall be performed by the continuous application of an ac potential of twice the rated voltage of the machine plus 1000 volts for one minute between all windings and ground and between phases except that this test does not apply to field windings; for high voltage machines designed to operate with the neutral insulated, the test voltage shall be not less than 7.5 times the line to neutral voltage.
- 28.5 The high potential test of field windings of ac generators shall be performed by the continuous application of an ac potential of ten times the excitation voltage, but in no case less than 1500 volts between field brush rigging and ground, and between field brush rigging of opposite polarity.
- 28.6 The high potential test of dc generators shall be performed by the continuous application of an ac potential of twice the rated voltage of the machine plus 1000 volts for one minute between:
- (a) all circuits and ground;
  - (b) shunt winding and other windings;
  - (c) brush rings of opposite polarity; and
  - (d) armature windings of generators, if provided with two commutators.
- 28.7 The commutation test on dc generators shall consist of the application of a momentary current of 50% in excess of rated current for 15 seconds and as near as possible to the rated voltage, without injurious sparking or injury to the commutator or brushes.
- 28.8 The commutation test on dc motors shall consist of the application of a momentary torque of 50% in excess of that corresponding to its rating, for 15 seconds with fixed brush setting, without injurious sparking or injury to the commutator or brushes.
- 28.9 The commutation of ac commutator motors shall be practically sparkless over the specified range of load and speed.
- 28.10 The overload test for generators shall be performed as an excess current of 50 percent for 15 seconds after attaining the temperature rise corresponding to rated load, the terminal voltage being maintained as near the rated value as possible; the foregoing does not apply to the overload torque capacity of the prime-mover.
- 28.11 The overload test for motors shall be performed at rated speed or, in the case of a range of speeds, at the highest and lowest speeds, under gradual increase of torque, the appropriate excess torque given below; synchronous motors and synchronous induction motors are required to withstand the excess torque without falling out of synchronism and without adjustment of excitation circuit preset at the value corresponding to rated load:

dc motors	50% for 15 seconds
polyphase ac synchronous motors	50% for 15 seconds
polyphase ac synchronous induction motors	35% for 15 seconds
polyphase ac induction motors	60% for 15 seconds
single phase ac motors	33% for 15 seconds.

- 28.12 Ships' service generators are to be capable of withstanding the mechanical and thermal effects of fault current for the duration of any time delay which may be fitted in a tripping device for discrimination purposes; they are to be capable of maintaining under steady-state short-circuit conditions a current of at least 3 times the full load for a duration of 2 seconds or, where precise data is available, for the duration of any time delay which may be fitted in a tripping device for discrimination purposes.



**29. TESTING SWITCHBOARDS AND MOTOR CONTROL CENTRES**

- 29.1 The following tests shall be carried out on those main, emergency and propulsion switchboards and motor control centres required to be tested:
- (a) satisfactory operation of overload protective devices for ship's service and emergency generators;
  - (b) high potential test; and
  - (c) insulation resistance test.
- 29.2 The satisfactory operation of the overload protective devices for generators shall be performed by passing the full value of the necessary current to actuate the tripping devices by the technique of primary injection or other means; settings for the long time trips, short time trips and instantaneous trips, where fitted, are to be posted near or within the switchboard(s).
- 29.3 The high potential test for all switching and control apparatus for systems over 60 volts should be twice the rated volts plus 1000 volts for one minute.
- 29.4 The insulation resistance shall be not less than 1 megohm between:
- (a) all current-carrying parts connected and ground; and
  - (b) current-carrying parts of opposite polarity or phase.

**30. TESTING MAIN PROPULSION CABLES**

- 30.1 All main cables for electric propelling machinery shall be tested in accordance with the following:
- (a) the high potential test shall be carried out on finished cables with either a single-phase ac voltage or a dc voltage , and the power available in the test equipment shall be sufficient to maintain constantly in the cable the specified value of the test voltage and the corresponding charging current;
  - (b) the test voltage shall be applied gradually to the cable so as to arrive at the specified value in about one minute;
  - (c) the test voltage for single-core, metal sheathed or metal armoured cables shall be applied between conductor and sheath or armour;
  - (d) the test voltage for single-core cables having an impervious non-metallic sheath and no further covering shall be applied between the conductor and the water, and the cable shall be immersed for at least one hour before the test;
  - (e) in the case of single-core cables having a non-metallic covering liable to be impaired if immersed in water, the test voltage shall be made on samples at least 1.02 m long, after having covered their surface with a metal foil;
  - (f) whichever the insulation type, each insulated core shall sustain for five minutes, without breakdown occurring, the values given in Table 30-1;

**TABLE 30-1**

Test Voltages for Propulsion cables

RATED VOLTAGE OF CABLE	TESTING VOLTAGE FOR 5 MINUTES	
	Volts ac	Volts dc
- 250	1500	3000
250 750	2500	5000
750 1100	3000	6000
1100 3300	10000	20000
3300 6600	16000	32000

- (g) immediately after the high potential test has been carried out, the insulation resistance shall be measured with a dc voltage of at least 300 volts using the same connections and procedures set forth in paragraphs (c), (d) and (e); and
- (h) the measurement of the insulation resistance shall be effected within one minute after application of the dc voltage provided that in certain cases, in order to reach a substantial steady state condition, the electrification time be prolonged up to a maximum of 5 minutes.

**31. TESTING TRANSFORMERS FOR LIGHTING AND POWER**

- 31.1 A high-potential test shall be carried out on every transformer described in Section 27 preferably with the transformer hot, immediately after the temperature rise test; the test shall be applied between the winding under test and the remaining windings, frame and tank of the transformer all connected to ground.
- 31.2 The test shall be made with ac at a convenient frequency between 25 Hz and twice the rated frequency and the full test voltage, as shown in Table below, and shall be maintained for one (1) minute without breakdown.

NOMINAL TRANSFORMER VOLTAGE	APPLIED VOLTAGE
1200 or less	4 K.V.
2400	10 K.V.
4160	12 K.V.

- 31.3 Induced potential: an ac potential of twice the maximum rated voltage of one winding at a suitable frequency shall be applied for a duration equal to
- $$1 \text{ min.} \times \frac{\text{Twice rated Frequency}}{\text{Test Frequency}}$$
- with a minimum of 15 seconds between the terminals of that winding with the ends of the other windings open.
- 31.4 Temperature rise: rated voltage at rated frequency shall be applied to the primary windings of a transformer with rated load connected to the secondary windings; as an alternative, tests resulting in losses approximating those obtained under normal or specified load conditions may be applied; the test shall be continued until constant temperatures are attained; the temperature rises shall not exceed those given in **Table 14-1**.
- 31.5 Insulation resistance test of the transformer windings shall be carried out, preferably with the transformer winding hot, immediately after the temperature rise test and shall be not less than one megohm.

## 32. TESTING STATIC POWER SUPPLIES

- 32.1 A high-potential test shall be carried out on every static power supply described in section 27, preferably with the unit hot, immediately after the temperature rise test; the test shall be made with ac of suitable frequency and applied for a period of one minute, both between parts connected to different circuits (where applicable) and between live parts and exposed non-current-carrying metal parts as follows:
- (a) rms voltage determined by the formula:
- $$2 \times \frac{U_p}{\sqrt{2}} + 1000 \text{ V}$$
- with a minimum of 2000 V.,  
Where  $U_p$  is the peak value of the highest voltage  
(transient over-voltage excluded) which occurs within the equipment in rated service.
- (b) where  $U_p/\sqrt{2}$  is not higher than 60 volts, the ac test voltage shall be 600 volts rms; and
- (c) where  $U_p/\sqrt{2}$  is in the range of 60 to 90 volts, the ac test voltage shall be 900 volts rms
- 32.2 **Temperature rise:** Rated voltage at rated frequency shall be applied to the input side of the static power supply with rated load connected to the output side; the test shall be continued until constant temperatures are attained.
- 32.3 **Overload test:** The static power supply unit shall be tested to ensure that the internal protective devices integral with the unit will function and protect the unit in accordance with the manufacturer's damage curve.
- 32.4 If a cooling fan is provided, the fire hazard due to fan failure shall be investigated.
- 32.5 Insulation resistance test of the wiring of the static power supply shall be carried out, preferably with the unit hot, immediately after the temperature rise test and the resistance shall be not less than one megohm.

### 33. INITIAL TESTING AND INSPECTION ONBOARD SHIP

- 33.1 The initial inspection, which may consist of a series of inspections during the construction of the vessel, shall include a complete inspection of the electrical installation and electrical equipment or apparatus. The inspection shall be such as to ensure that the arrangement, materials and installations thereof, fully comply with the applicable section of this Standard and are in accordance with approved plans. The inspection shall also be such as to ensure that the workmanship of all equipment and apparatus and the installation thereof is, in all respects, satisfactory.
- 33.2 The insulation resistance shall be measured by self-contained instruments such as a direct reading ohmmeter of the generator type, applying a voltage of at least 500 volts. When an insulation test is made on a circuit incorporating capacitors of a total capacitance exceeding 2 microfarads, an insulation tester of the constant-voltage type should be used.
- 33.3 Before switchboards, motor control centres and distribution panels are put into service, their insulation resistance shall be not less than 1 megohm when measured between each bus-bar and ground and between each insulated bus-bar and the bus-bar connected to the other pole or poles; this test shall be made with all circuit breakers and switches open and all fuse-links for pilot lamps, ground indicating lamps, voltmeters, etc. removed and voltage coils temporarily disconnected.
- 33.4 On all lighting and power circuits, a test for insulation resistance between all insulated poles and ground and, where practicable, between poles shall be applied to all permanent wiring.
- 33.5 Each circuit should have an insulation resistance between conductors and between each conductor and ground of not less than the following:
- |                 |               |
|-----------------|---------------|
| Up to 5 A load  | 2 megohms     |
| Up to 10 A load | 1 megohm      |
| Up to 25 A load | 400,000 ohms  |
| Up to 50 A load | 250,000 ohms  |
| Over 50 A load  | 100,000 ohms. |
- 33.6 All generating sets shall be run until constant temperature has been reached, after which commutation, electrical characteristics, overspeed trips, governing, range of excitation control, lubrication and absence of vibration shall be satisfactorily demonstrated.
- 33.7 The insulation resistance of all generators shall be measured both in the cold condition and in the warm condition immediately before and after running at normal full load.
- 33.8 All switchgear shall be loaded as nearly as practicable to its full load and no overheating shall take place due to faulty connections or incorrect rating. Those vessels with an aggregate connected load of 500 kW or more shall conduct a thermal scan of the switchboard main connections and bus work together with the generator connections and transformers above 10 kVA.
- 33.9 Switches and circuit breakers shall be operated on load and, where practicable, operation of their over-current, under-voltage and auxiliary trip units satisfactorily demonstrated.
- 33.10 Reverse power relays, reverse current relays, preferential tripping relays and all electrical and electro/mechanical interlocks shall be satisfactorily operated.
- 33.11 Each motor with all its associated control equipment shall be run under operating conditions for a sufficient length of time to demonstrate correct alignment, wiring, capacity, speed, and satisfactory operation; motors driving pumps, ventilation fans, and similar loads shall be operated as nearly as practicable under their individual service conditions; motors driving cargo winches shall hoist and lower their specified loads; motors driving warping capstans, machine tools, and other similar machines, shall be run to demonstrate suitability.
- 33.12 The remote control units for stopping ventilation fans, oil pumps and pumps discharging overboard in way of survival craft shall be satisfactorily operated.

- 33.13 Tests shall be carried out on power and lighting circuits to verify that the allowable voltage drop, as specified in **Section 5.1 (b)** of this standard has not been exceeded; circuits shall be operated as nearly as is practicable, at their full load rating during these tests.
- 33.14 Where the power developed by the main propulsion units is transmitted to the propeller by means of generators and motors:
- (a) a dock trial of sufficient duration shall be made to prove that all propulsion machinery, controls and interlocks function satisfactorily;
  - (b) an insulation resistance test should be made on all motors, generators and main cabling in the cold condition immediately before the machinery is put into operation and in the warm condition immediately after completion of trials and the values obtained shall be not less than 1 megohm; the insulation resistance values obtained shall be recorded and kept onboard as a permanent reference for future insulation resistance tests.
- 33.15 The functioning of the complete emergency electrical supply shall be tested and this shall include the following; where applicable:
- (a) operation of the emergency generator automatic starting system;
  - (b) operation of the transitional emergency battery automatic transfer system;
  - (c) capacity test of the emergency accumulator battery; and
  - (d) operation of the emergency lighting system.
- 33.16 Interior communications systems and alarm systems shall be tested to determine their suitability and to verify their specified functioning; particular attention shall be paid to the testing of the operation of all essential electrical communication systems including:
- (a) electric engine order telegraphs;
  - (b) electric docking telegraphs;
  - (c) automatic fire alarm and detection systems;
  - (d) public address system; and
  - (e) general alarm system.
- 33.17 The operation of electric and electro/hydraulic steering gear shall be tested with particular attention paid to the function of the motor overload alarm, motor stopped indication and supply circuit breaker tripped alarm; where duplicate power supplies to a manual transfer panel are provided it shall be verified that the arrangement of switches or links on the panel is such as to permit either supply to be connected to either motor but not to permit both motors to be connected to one supply.
- 33.18 Electric cable shall be checked during installation for size and type as shown on the approved plans; the adequacy of cable supports shall be checked and it shall be ascertained that no cable is installed in the proximity of steam pipes or other hot objects and that the cables have not been damaged during the installation due to excessive pulling force having been applied, or due to bends or sharp or rough edges of cable supports or bulkhead penetrations or similar abrasions; cable penetrations required to be watertight shall be checked for proper packing of the terminal or stuffing tubes.
- 33.19 Rotating electrical machinery shall be checked to assure that rotating and/or un-insulated parts are adequately shielded from accidental contact by personnel.
- 33.20 Switchboards shall be checked for hand-rails, guard-rails, working spaces, insulating floor covering, drip covers and enclosures for backs and ends; switchboard mounted apparatus shall be checked for identifying nameplates; circuit nameplates shall be compared with the rating or setting of the overcurrent devices and with the approved plans; the accessibility of items requiring maintenance or adjustment shall be checked; meters shall be checked for proper operation; the operation of automatic switchgear and mechanical and electrical interlocks shall be observed.

- 33.21 Motor starters shall be checked to ensure proper starting of the motor under service conditions and that properly rated overcurrent devices are installed; each motor starter not completely disconnected from all sources of potential when the disconnect switch is opened (due to electrically interlocked circuits necessary for proper operation of the apparatus or for other valid reasons) shall be checked to ensure that attention is directed to such conditions by a suitable warning.
- 33.22 The accessibility of electrical apparatus for normal inspection and maintenance shall be observed; the accessibility of junction boxes and the like in way of panelling shall be noted during construction of a vessel; hinged doors of motor starters and similar apparatus shall be checked for interference with adjacent structural parts or apparatus.
- 33.23 It shall be determined that metal enclosures for electrical equipment are grounded, either by the method of mounting or by ground leads; portable equipment shall be checked for grounding through one conductor of the supply cable.
- 33.24 All propulsion and auxiliary machinery control and safety systems installed to comply with the requirements for an automated machinery system or an unmanned machinery space shall be checked for material condition and operation.
- 33.25 Storage batteries used for ship's service and emergency diesel driven generator starting and diesel driven main engine starting shall be checked for capacity; the batteries shall have sufficient capacity without recharging to provide not less than twelve consecutive starts of each main engine if of the reversible type and not less than six consecutive starts if of the non reversible type; for diesel driven generators, not less than six consecutive starts.
- 33.26 Electric re-heat systems are to be checked for normal operation; overheat cut-outs are to be checked for proper operation and temperature rating; electrical connections are to be checked to ensure that they are tight; the interior of re-heat boxes is to be checked to ensure that they are free from excessive amounts of combustible dust.

## 34. PERIODIC INSPECTIONS

- 34.1 The inspection of electrical installations at the periodic inspection incident to re issuance of a safety certificate of inspection shall include an inspection of all items enumerated in Section 33.1 and 33.6 to 33.25 inclusive to the extent necessary to determine mechanical and electrical condition and performance and as per the applicable subsection of this chapter; particular note shall be made of circuits added or modified after the initial inspection.
- 34.2 All repairs, additions alterations are undertaken; shall comply with the approved plans.
- 34.3 Where the control of the propulsion machinery or the propeller is effected by electric or electronic means a complete inspection of the control system shall be conducted annually.
- 34.4 Where appropriate, in the interest of safety, more frequent inspections should be carried out.
- 34.5 Where the main source of electrical power is used for supplying power for lighting purposes only:
- (a) the equipment and installation shall be generally inspected and tested under working conditions and electric cables inspected as far as may be practicable without dismantling any fixtures or casings;
  - (b) an insulation resistance test shall be made on generators, cables and fittings, using a direct indicating ohmmeter of the generator type, applying a d.c. voltage of 500 volts and the insulation resistance measured shall be not less than 100,000 ohms; for cargo vessels of less than 20 years of age the option exists whereby the insulation resistance tests may be performed on a five year periodicity; and
  - (c) all generators shall be run in turn or simultaneously, and all main switches and circuit breakers operated on load.
- 34.6 Where the main source of electrical power is also used for supplying power for driving essential auxiliary machinery, steering gear or windlass:
- (a) generators and all motors driving essential auxiliary machinery shall be inspected generally as far as may be practicable without dismantling any fixtures or casings unless such dismantling is deemed necessary as a result of test or observation;
  - (b) an insulation resistance test shall be made on generators, motors, cables, heaters and fittings using a direct indicating ohmmeter of the generator type, applying a d.c. voltage of 500 volts; the insulation resistance measured shall be not less than 100,000 ohms; for cargo vessels of less than 20 years of age the option exists whereby the insulation resistance tests may be performed on a five year periodicity; and
  - (c) all generators shall be run in turn or simultaneously and all main switches and circuit breakers operated on load.
- 34.7 Where the power developed by the main propulsion units is transmitted to the propeller by means of generators and motors, an inspection shall be conducted as follows:
- (a) the main propulsion generators and motors shall be inspected as far as may be practicable, particular attention being paid to the ends of all windings of stators and rotors; all air ducts in stator coils and the ventilating holes in rotors and retaining rings of alternators shall be carefully examined;
  - (b) all cable runs shall be examined over their entire length, particular attention being paid to the grounding of metallic protective coverings of sheaths;
  - (c) generator circuit breakers and set-up switchgear shall be examined and tested for mechanical operation at no load;
  - (d) high potential bus insulators and supports shall be inspected and found free from oil, dust or contamination liable to cause tracking to ground;



- (e) The propulsion system excitation and control systems shall be energized and all permissive interlocks and indicators inspected; the excitation and control power need not be applied to the main machinery during this inspection; and
  - (f) the insulation resistance of each propulsion motor and generator shall be tested and the values obtained compared with the original readings and those in the ships log; corrective action shall be requested where the measured insulation resistance is less than 1 megohm or where any abrupt decrease in the order of 25% of the original or previously recorded values are noted.
- 34.8 The functioning of the complete emergency electrical supply system shall be tested and this shall include the following, where applicable:
- (a) operation of the emergency generator automatic starting system;
  - (b) operation of the transitional emergency battery automatic transfer system; and
  - (c) operation of the emergency lighting system.
- 34.9 All essential electrical communication systems shall be tested to verify their specified functioning.
- 34.10 The operation of electric and electro/hydraulic steering gear shall be tested with particular attention paid to the functioning of the motor overload alarm, motor stopped indication and supply circuit breaker tripped alarm, also the setting of switches or links on the transfer panel where applicable.
- 34.11 Generator circuit breakers for generators rated 100 kW and above shall be tested every five years to verify initial trip settings and satisfactory operation; the tests may be conducted using either primary or secondary injection methods; if the test is performed by secondary injection the integrity of all the circuit breaker's associated current transformers is to be verified on a ten year periodicity. The actual generator circuit breaker settings shall be permanently indicated in an accessible position within each circuit breaker compartment.

## 35. ESSENTIAL SERVICES

- 35.1 The following items shall be considered as essential services for the purpose of these Standards:
- (a) air compressors for main engines;
  - (b) scavenge blowers;
  - (c) bilge pumps;
  - (d) ballast pumps;
  - (e) fire and sprinkler pumps;
  - (f) circulating and cooling water pumps;
  - (g) condenser circulating pumps;
  - (h) condensate pumps;
  - (i) feed water pumps;
  - (j) fuel valve cooling pumps;
  - (k) lubricating oil pumps;
  - (l) oil fuel pumps;
  - (m) boiler fans for forced and induced draught;
  - (n) steering gear;
  - (o) windlasses;
  - (p) C.P. propeller stand by servo oil pump motors;
  - (q) lighting;
  - (r) cargo oil pumps;
  - (s) machinery space ventilation;
  - (t) ventilation fans for hazardous areas;
  - (u) thruster motors (not to include bow thruster(s); and
  - (v) communication equipment, in accordance with the applicable Regulation(s) and/or Rules as listed in subsection 35.2.
- 35.2 Notwithstanding the items listed in subsection 35.1, the Regulations and Standards listed below will provide specific requirements for electrical equipment and communicating equipment in each class or type of vessel:
- (a) Fire Detection & Extinguishing Equipment Regulations;
  - (b) Small Fishing Vessel Inspection Regulations;
  - (c) Large Fishing Vessel Inspection Regulations;
  - (d) Collision Regulations;
  - (e) Hull Construction Regulations;
  - (f) Small Vessel Regulations;
  - (g) Towboat Crew Accommodation Regulations;
  - (h) Arctic Shipping Pollution Prevention Regulations;
  - (i) Search Initiator Buoy Regulations;
  - (j) Ships Elevator Regulations.
  - (k) Marine Machinery Regulations

### 36. DRAWINGS AND DATA FOR SUBMISSION

- 36.1 For new construction, the following drawings and data are to be submitted to the Board for inspection:
- Load Analysis;
  - Short-circuit Analysis;
  - Co-ordination Study of Main and Emergency Distribution Systems;
  - Elementary Single Line Diagram of Main and Emergency Distribution;
  - Elementary Single Line Diagram of Propulsion System, Wiring Diagram of Propulsion Control Circuits;
  - Switchboard (to include general arrangement, wiring diagram, nameplates and bill of material);
  - Starter Drawings (for all Essential Services as listed in Section 35);
  - Lighting Circuits Wiring Deck Plan or Book of Diagrams (including symbol list);
  - Power Circuits Wiring Deck Plan or Book of Diagrams (including symbol list) for passenger ships only;
  - Cable Routing Arrangements or Wiring Deck Plans for vital and emergency circuits;
  - Essential Interior Communication Systems-Block Diagrams;
  - Essential Alarm Systems-Block Diagrams;
  - Fire Detection System-Wiring Deck Plan and Block Diagram and Bill of Material;
  - Automation or Remote Control Systems and Boiler Controls (including description of operation);
  - Plan of Hazardous Zone(s) including type and classification of all electrical equipment located there-in;
  - the emergency diesel generator automatic start wiring diagram and description of operation for the automatic start circuitry ;
  - Machinery Arrangement of Emergency Generator Room;
  - Programmable Logic Controllers - details of the hardware configuration and graphic representation of the program, e.g. flow charts, statement list, function or block diagram.
- 36.2 Where reconstruction or modifications are being carried out on an existing installation, plans covering all aspects of the modifications are to be submitted to the Board for inspection.

### **37. DISTRIBUTION PANELS AND SUB-DISTRIBUTION ASSEMBLIES OTHER THAN SWITCHBOARDS FOR DISTRIBUTION OR PROPULSION**

- 37.1 Distribution panels shall be constructed of corrosion resistant material with the degree of protection suitable for the location in accordance with the most recent edition of CSA Canadian Electrical Code Part 1 C22.1 or IEC Standard 592.
- 37.2 All current carrying components shall be manufactured from copper and surfaced to inhibit corrosion and reduce contact resistance; bus sizes to be in accordance with Table 9-1 of Section 9.
- 37.3 Each outgoing circuit shall be identified with a nameplate or a number and placed on a directory card affixed to the panel door or adjacent to the circuit.
- 37.4 Circuit breakers shall be suitable for the type of voltage (ac or dc), the voltage range and be in accordance with Section 2.7.
- 37.5 Distribution panels or sub-assemblies constructed of a molded composition shall be of a flame retardant material in accordance with ASTM D229-96 (American Society for Testing and Material Standards) and shall also be impervious to oil, moisture and ultra violet radiation.
- 37.6 Circuit breakers provided in distribution panels and sub-assemblies shall be in accordance Sections 9.3.10, 11.6, 11.7, 11.8 and 11.9.

## **PART II**

---

### **ELECTRICAL SYSTEMS LESS THAN 50 VOLTS**

#### **50. TYPES OF SYSTEMS**

- 50.1 Subject to subsection 50.4, all distribution systems shall be of the 2-wire type with insulated feed and return conductors in compliance with subsections 50.2 and 50.3.
- 50.2 Ungrounded distribution systems shall have all current carrying conductors, including the source of power and all accessories, completely insulated from ground throughout the system.
- 50.3 Grounded distribution systems shall utilize the common ground part of the vessel only as a means of maintaining the return side of the system at ground potential; the grounded side of the system shall be of negative polarity.
- 50.4 The engine block may be used as a common ground return for electrical accessories mounted on the engine, except on metallic vessels where the engine block is not electrically isolated from the hull.

## 51. SYSTEM PROTECTION

- 51.1 Electrical systems and equipment shall be protected from the effects of overcurrent by suitably rated fuses or circuit breakers.
- 51.2 Circuit breakers shall be:
- (a) the proper voltage type and rating;
  - (b) be the manual reset type;
  - (c) have instantaneous short-circuit protection capable of repeatedly opening the circuit in which they are used without failure; and
  - (d) be of trip-free type.
- 51.3 Fuses of the proper rating may be used for circuit protection, but shall be used in conjunction with a switch located between the fuse and source of power; fuse holders shall be suitable for use in sea atmospheres.
- 51.4 A master battery isolating switch shall be provided in accordance with the following:
- (a) be capable of carrying the continuous maximum current of the system in each ungrounded conductor;
  - (b) the continuous rating of the switch shall be not less than the total ratings of the main overcurrent protection devices connected to it;
  - (c) be capable of carrying the intermittent maximum cranking current of the largest engine cranking motor;
  - (d) shall be located as close to the battery as practicable but readily accessible in the event of an emergency;
  - (e) when used with a diode rectified alternator or third brush generator incorporate a means for breaking the field circuit when the battery load is removed from the system.
- 51.5 A fuse or manual-reset type circuit breaker shall be provided in each ungrounded feeder to the power distribution panel, except for the battery cable from the battery to the starter.
- 51.6 A fuse or manual-reset type circuit breaker shall be provided at the main distribution panel for each separate electrical circuit.
- 51.7 Each ungrounded conductor of circuits supplying lights, motors or electrical accessories shall be protected against overload at the distribution panel or switchboard serving as the source of power; each navigation light branch circuit shall be protected by a separate overcurrent device installed in each ungrounded conductor.
- 51.8 If, for any reason, the cable size is reduced at a junction box, the rating of the circuit overload protective device shall be based on the current-carrying capacity of the smallest conductor in the circuit.
- 51.9 The conductors supplying motors and motor-operated appliances shall be protected by an over-current device which is designed to handle the inrush current; the motor protective overload device shall be rated or set at not more than 115 percent of the motor full load current rating for enclosed motors and not more than 125 percent of the rating for open motors.

## 52. EQUIPMENT GROUNDING

- 52.1 In steel and aluminum vessels, non-conducting exposed metal parts of electrical equipment that requires to be grounded shall be effectively grounded to the hull.
- 52.2 On wood and composite ships, a continuous ground conductor shall be installed to facilitate the grounding of non-conducting exposed metal parts of electronic and communication equipment that requires to be grounded; the ground conductor shall terminate at a point on the main engine or at a copper plate of area not less than 0.2m<sup>2</sup> fixed to the keel below the light waterline so as to be fully immersed under all conditions of heel.
- 52.3 Every grounding conductor shall be of copper or other corrosion-resistant material and shall be securely installed and protected, where necessary, against damage and against electrolytic corrosion.
- 52.4 Every ground connection to the ships structure, or on wood and composite ships, to the continuous ground conductor, shall be made in an accessible position and shall be secured by a screw or connector of brass or other corrosion-resistant material used solely for that purpose.

### 53. LIGHTNING CONDUCTORS

- 53.1 Lightning conductors shall be fitted to each mast of all wooden and composite vessels and to each mast of steel or aluminum vessels having wooden masts or topmasts except where the height of any antenna exceeds that of the masts and the antenna is equipped with lightning arrestors or other effective devices.
- 53.2 Lightning conductors shall be composed of continuous copper alloy tape or cable having a cross-sectional area of not less than 25mm<sup>2</sup> (#4 AWG) which shall be attached by copper rivets or clamps to a copper spike ( air terminal ) not less than 13 mm in diameter, projecting at least 150 mm above the top of the mast; the copper alloy tape or cable shall be run to terminate at a copper plate of area not less than 0.2 m<sup>2</sup>, fixed to the keel below the light water line so as to be fully immersed under all conditions of heel or trim.
- 53.3 No grounding conductor shall be attached to the lightning conductor plate.
- 53.4 The copper plate shall be separate from, and in addition the copper plate for terminating the grounding conductor.



## 54. ELECTRICAL EQUIPMENT

- 54.1 Electrical equipment appliances, accessories and fittings shall comply with Part 1 Section 2.7, 2.8 and 2.15.
  - 54.1.1 where special marine-type equipment is required and there is no standard for it, it shall be of type that is safe and effectively fulfils the purpose for which it is intended.
- 54.2 Electrical equipment shall be of a type suitable for the location and the environment and shall be positioned so as not to be unnecessarily exposed to mechanical damage; light fixtures are to have globes or guards.
- 54.3 Electrical equipment shall not be installed where explosive or flammable gases or flammable vapours are liable to accumulate or where risk of explosion might arise unless the apparatus is of the certified safe type.
- 54.4 Electrical distribution panels and electrical equipment shall be located in accessible well-ventilated locations protected from rain and spray; where necessary, drip-proof equipment shall be provided.

## 55. BATTERIES

- 55.1 Batteries shall be located in a compartment, locker or box reserved solely for that purpose; they shall not be located in accommodation spaces; batteries intended for emergency purposes shall be installed in a protected location as high as possible in the vessel.
- 55.2 Batteries shall not be tapped for voltages other than the total voltage of all the cells comprising the battery.
- 55.3 Batteries shall be so located that gas generated in charging will be readily dissipated by natural or mechanical ventilation; the ventilation requirements are to comply with Section 19.5 Ventilation of Batteries.
- 55.4 Batteries shall be accessibly located, provided with suitable supports, and secured against movement arising from the motion of the boat.
- 55.5 Alkaline and lead-acid batteries shall not be installed in the same compartment.
- 55.6 Batteries shall be located in a liquidtight tray or liquidtight box of adequate capacity to retain normal spillage or boilover of the electrolyte; the liquidtight tray or box shall be constructed of, or lined with materials resistant to deterioration by the electrolyte.
- 55.7 A non-conductive, perforated cover or other suitable means shall be provided to prevent accidental shorting of battery terminals.
- 55.8 Batteries with metal cell containers shall be assembled in non-conductive trays having suitable insulating cell supports; provision shall be made to prevent other conductive materials that could cause a short-circuit from coming in contact with the cell containers.
- 55.9 Where batteries are used as the primary power source, the battery capacity should be at least 50% greater than the essential load on a 10 hour discharge rate.
- 55.10 Indication shall be provided that the battery is being maintained in a state of charge.
- 55.11 Valve regulated or sealed batteries shall meet the installation and location requirements of the applicable subsections of Section 19 ACCUMULATORS and BATTERIES.

## 56. CABLES

- 56.1 All cables shall have a protective covering of either watertight metallic sheath or impervious non-metallic sheath, compatible with the insulation if an armour is provided it shall be in accordance with Section 12.5.
- 56.2 Cables may be of a suitable commercial grade with stranded copper conductors and rated for at least 75°C service.
- 56.3 Portable cords or portable cables shall not be used for fixed wiring.
- 56.4 Cables shall be effectively supported and secured in order to prevent chafing or other injury; on wood or composite vessels the cables shall be run in metal trays, or shall be secured by clips or straps of non-ferrous material; staples shall not be used for this purpose.
- 56.5 Cables shall be routed as high as possible above the bilge with prime consideration given to the protection of the wiring from mechanical damage and heat damage.
- 56.6 Exposed wiring subject to mechanical damage shall be protected by conduit or other equivalent means.
- 56.7 Cables terminating in equipment capable of generating high temperatures such as lighting fixtures, etc., shall be suitable for operation at the temperature of the equipment.
- 56.8 Current carrying capacities of cables will be assigned in accordance with Table 12-1, unless otherwise stated by the cable manufacturer.

**57. SWITCHBOARDS & DISTRIBUTION PANELS**

- 57.1 Switchboards and electrical distribution panels shall be located in accessible well ventilated locations protected from rain and spray; where necessary, panels shall be provided with a drip shield.
- 57.2 Switchboards or other electrical panels or junction boxes located adjacent to weather decks or in open cockpits shall be enclosed or protected from deck wash.
- 57.3 Switchboards shall be so installed that no pipes or tanks are above them within the same space; where this is unavoidable, pipes shall be without joints in such positions.
- 57.4 Switchboard bus-bar supports shall be of substantial and durable construction and shall be capable of withstanding electro-mechanical stresses which may arise from short-circuit faults; all panels shall be of substantial construction to withstand vibration, and hinged panels and doors of dead front switchboards shall be provided with positioners and stops.
- 57.5 Bus-bars and their connections shall be of copper, all connections being made so as to inhibit corrosion.
- 57.6 Switchboards and panel boards shall be designed so there are no exposed live parts accessible to operating personnel under normal operation.

**58. DISTRIBUTION**

- 58.1 Joints and connections in all electrical conductors shall be mechanically and electrically secure and made only in junction or outlet boxes.
- 58.2 Joints shall be capable of withstanding the vibration and movement encountered in normal service.
- 58.3 Metal alloys used shall be corrosion-resistant and galvanically compatible with copper conductors.
- 58.4 With the exception of the thread cutting type of connector, twist-on type connectors shall not be used for making joints in cables.
- 58.5 Lampholders shall be constructed wholly of flame-retardant and non-hygroscopic material and supports of live parts should be non-combustible material.
- 58.6 Lamps which are exposed to the weather, spray and drip shall be enclosed in weatherproof fittings.
- 58.7 Navigation light installations for systems under 50 volts shall be in accordance with Sections 11.37, 11.38 and 51.7.
- 58.8 The drop in voltage from the switchboard to every point on the installation when the conductors are carrying the maximum service shall not exceed:
  - (a) for lighting circuits, 5% of the nominal voltage; and
  - (b) for mains and power circuits, 2% of the nominal voltage.