

How to Lock Out Crime: Home Security—Doors

If you are like most Canadians, you are concerned about the safety of your home and your community. One particular type of crime that worries Canadians is breaking and entering or burglary. Recent statistics show that burglary accounts for 22 per cent of all property crime.

The **How To Lock Out Crime** series, jointly prepared by Canada Mortgage and Housing Corporation (CMHC) and the Royal Canadian Mounted Police (RCMP), will make you more aware of burglary and its dynamics and show you how to minimize the likelihood that this crime will happen to you.

The **How To Lock Out Crime** series promotes a **proactive** approach to safety and security. By knowing the conditions favourable to burglars and taking steps to eliminate those conditions, you can greatly reduce the chances that your home will be burgled. Being proactive and implementing a well-thought-out plan can:

- significantly reduce the opportunity for a crime to be committed; and

- minimize the consequences—both personal and property damages—if a crime does occur.

In **Home Security 101**, you were asked to do a visual assessment of your yard and home. **Home Security—Doors** suggests ways you can improve your door security.

More than locks

Securing your doors against burglars takes more than good locks. A well-designed doorway is a miniature security system in which door, frame and hardware—the locks, hinges and fasteners—work together. The system as a whole is only as strong as its weakest part.

This fact sheet conforms to the 2005 National Building Code, which is used as a model for most provincial and municipal building regulations. *Recommendations based on Code requirements are shown in italics, like this.* Non-mandatory recommendations are in regular type. Check with your municipality's building department to see if there are other requirements.

Remember—no security system is 100 per cent effective. The methods outlined here will not always discourage a professional burglar from breaking into your home. But they will, in most instances, persuade amateurs—who are by far the most frequent offenders—to look for an easier target.

Exterior doors

- *Burglar-resistant doors should be installed at all exterior entrances to the dwelling and at the entrance leading from the garage into the house.*

Burglar-resistant doors are usually made of wood or metal.

Wood doors should be of solid-core or rail-and-stile construction at least 45 mm (1 1/4 in.) in overall thickness. Since the panel portions of the rail-and-stile doors are the weakest parts, they should not exceed half of the door area and should be at least 19 mm (3/4 in.) thick at the thinnest part.

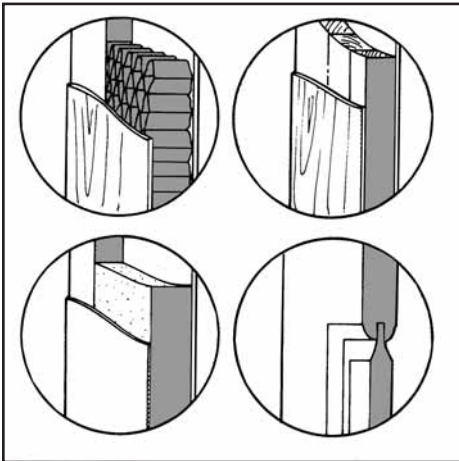

Figure 1 Cutaway view shows interior frame of hollow door and solid-core door with wood facing.

Burglar-resistant doors should meet the Canadian General Standards Board's standard for insulated steel doors (CAN/CGSB 82.5M) if made of steel, or the Canadian Standards Association's standard for wood flush doors (CAN/CSA 0132.2-M) if made of wood.

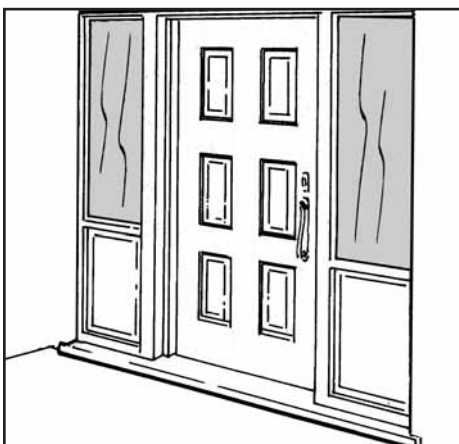

Figure 2 Breaking the glass will not help a burglar reach the lock if the opening is protected with metal mesh.

The CSA standard for wood flush doors requires the doors to be marked to show that they are exterior grade and meet the standard.

Plank doors are similar to solid-core wooden doors but come without a facing. Homeowners should be wary of any door with an internal cedar frame, which tends to split along the grain when pressure is applied at the lock.

Ordinary glass in doors and in sidelights—the glass panels on one or both sides of the door—can easily be broken to gain access to the door lock. Replace ordinary glass with laminated glass, wired glass or burglar-resistant acrylic or polycarbonate plastic.

Tempered glass, while stronger than ordinary glass, can be easily shattered by concentrated impact and offers little challenge to forced entry. Fitting a protective metal mesh or grille over the glass, or installing an alarm that will sound if the glass is broken are other protection methods.

Mail slots built into the door should be no larger than 12 mm X 150 mm (1/2 in. X 6 in.) and should not be located within 450 mm (18 in.) of a lock. If the slot is larger, install a metal box or deflecting baffle behind the slot to restrict access through it to the door hardware.

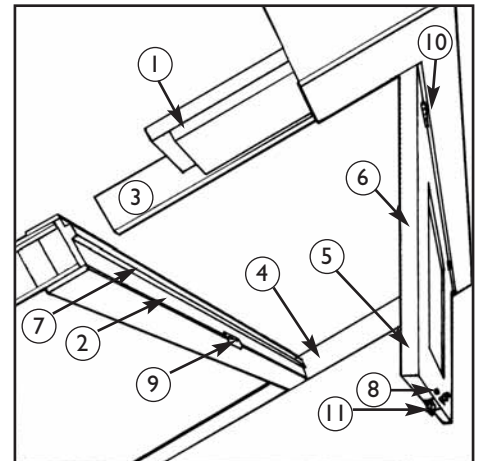

Legend:

1 – structural framing	7 – door stop
2 – jamb	8 – lock
3 – head	9 – strike plate
4 – sill	10 – hinge
5 – stile	11 – bolt (of lock)
6 – rail	

Figure 3 Cutaway view of door and frame.

Door frames

Doors are hung in a frame consisting of two vertical members (jamb) and one horizontal member (head). This frame is supported by the structural framing or studs. A door should fit snugly into the frame with not more than a 3 mm (1/8 in.) clearance on either side and at the top, and not more than 6 mm (1/4 in.) at the bottom.

Metal strike plates (*see* Other Door Hardware) can be incorporated into the door jamb, where the door latch and deadbolt meet the jamb. This will prevent an intruder from wedging a crowbar between the door and frame and crushing the frame to free the bolt.

Metal frames for exterior doors must incorporate a thermal break that will prevent the metal from conducting heat away from the home's interior.

To resist spreading under force, the space between the door jambs and the adjacent studs on each side of the door must be filled with blocking at lock height.

If the space is small, this can be done using shims. Place shims or blocking at the top and bottom hinges to strengthen the assembly. Sidelights will seriously weaken the frame. To reinforce the frame, remove the inside trim between the door and sidelight and fasten a length of flat steel 25 mm (1 in.) wide to the wood of the frame. For best effect, the metal brace should extend the full height of the door frame and be held in place with long screws at 300 mm (12 in.) intervals.

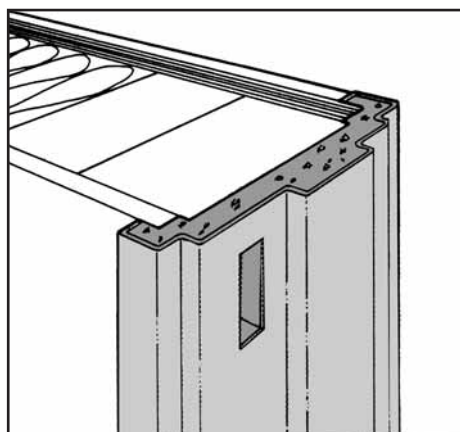

Figure 4 Steel door frame backed by cement grout.

Hinges and Fasteners

Burglar-resistant doors should swing inward so that the hinge pins cannot be removed from the outside, or the hinges should be modified to make them secure.

This can be done by using non-removable hinge pins or by flattening the ends of conventional pins. Hinge pins can also be secured by drilling and tapping a hole through the hinge into the pin and installing a machine screw as illustrated. The screw head can then be cut off or ground down to prevent its removal.

Another way to secure the door is to install metal pegs that will engage both leaves of the hinges when the door is closed (*see* Figure 7). This will prevent the removal of the door if the hinge pins are taken out.

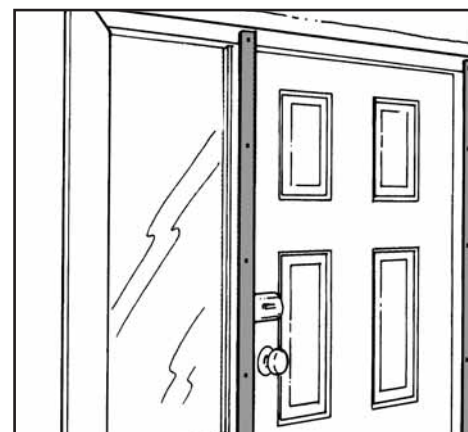

Figure 5 Use long screws to install metal brace on frame of door with sidelights.

If the screw holes in the hinge leaves line up when the hinge is closed, a projecting steel peg can be installed in one screw hole that will engage a matching hole in the opposite leaf when the door is closed; otherwise, the hinge must be drilled to provide matching holes before the pegs are installed.

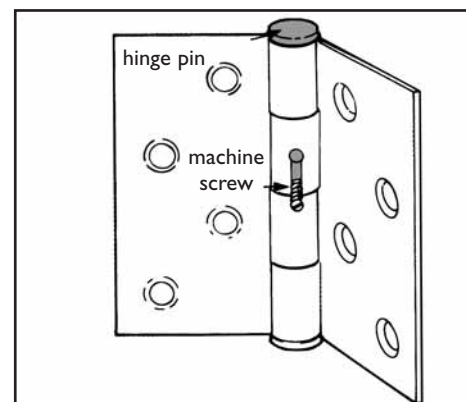

Figure 6 Make your hinge pins non-removable by flattening both ends of the pins or by inserting a small, non-removable screw into the middle of each pin.

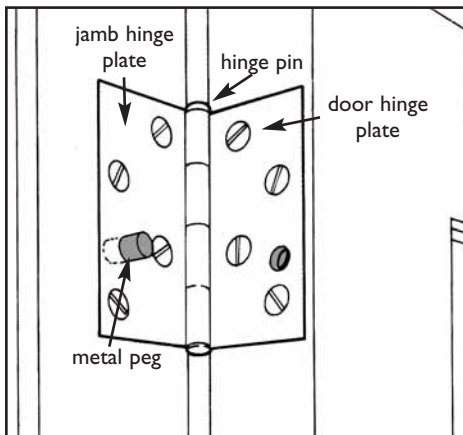

Figure 7 The addition of a metal peg or screw without a head helps secure the door in case the hinge pin is removed.

Exterior doors should be hung with at least three, 90 mm X 90 mm (3 1/2 in. X 3 1/2 in.) solid butt hinges at least 2.5 mm (1/10 in.) thick.

Inadequate fasteners are often the weak spot in an otherwise secure door. Hinge screws that do not have sufficient wood penetration can be torn loose with a well-placed kick.

At least two screws per hinge should penetrate 30 mm (1 1/4 in.) into solid wood at the jamb where wood door frames are used. Screws fastening the hinges to wood doors should be at least 25 mm (1 in.) long. In the case of metal frames and metal doors, the screws should be not less than 10 mm (3/8 in.) No. 10 machine screws.

All fasteners exposed to tampering should be non-removable. Use one-way screws or grind out the slot with an electric grinder. Another method is to fill in the driving recess with “liquid metal.”

Or, use a Phillips or Robertson screw and then round out the cross- or box-shaped driving recess with a drill. When using these fasteners, be sure the lock or hinge you are installing is properly positioned and working well; it will be very difficult to remove the one-way fasteners once they are tightened.

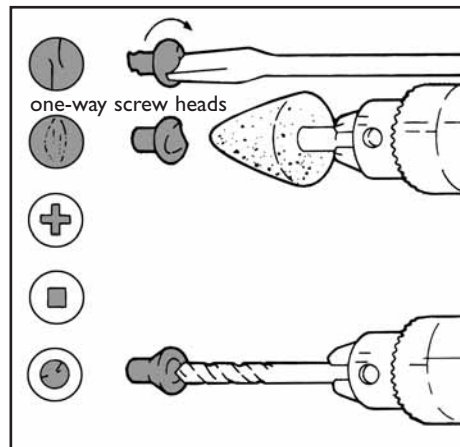

Figure 8 Grind out the screw slot or round out the driving recess with a drill to prevent removal of the screw.

Door locks

Homeowners confronted by the vast array of locks available for residential use need not be disheartened. Essentially, there are only two types of locks: **spring-latch, or slip bolt, and deadbolt.**

In a spring-latch, the bolt (that is, the part of the lock that projects beyond the edge of the door) is spring-loaded and is activated when the handle is turned. The familiar key-in-knob locks, found on most doors, are this type.

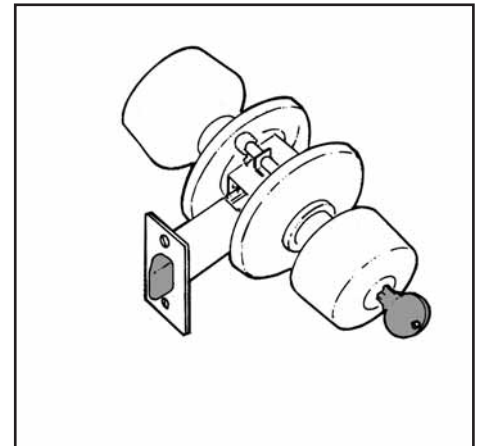

Figure 9 Key-in-knob lock with spring latch.

Spring-latch locks are inexpensive, easy to install and convenient to use. Unfortunately, they are also the easiest to defeat. The bevelled latch of the spring-latch lock can be pushed out of its strike with a piece of plastic (credit card) to open the door. Even if the latch is protected (by a piece of angle-iron fixed to the door jamb, for example), the entire lock can be twisted off the door with a pipe wrench or smashed off with a hammer. Spring-latch locks equipped with a dead-latch plunger, which prevents the bolt from being forced back into the lock when the door is closed, are also vulnerable to this type of attack.

A deadbolt can only be activated by a key inserted into the cylinder. Because it is not bevelled or spring-loaded, the bolt cannot be pushed back into the lock. Deadbolts are either single or double cylinder, horizontal or vertical.

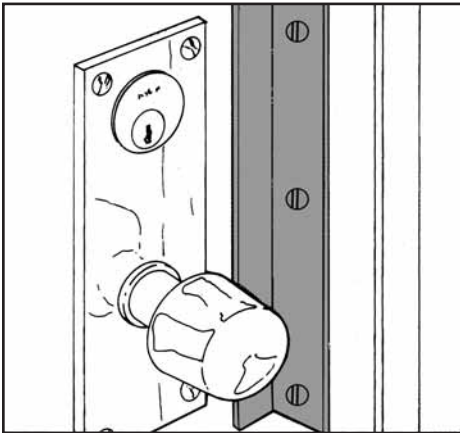

Figure 10 A piece of angle iron mounted on the door jamb protects the latch from the insertion of credit cards. An escutcheon plate protects the lock cylinder.

Single-cylinder deadbolts are operated by a key from the outside (or by pressing a combination of numbers on a keypad) and by a thumb-turn from the inside. Double cylinder deadbolt locks that must be operated by a key from both sides are also sold as burglar-resistant locks. They are not permitted under current codes because of their potential for restricting escape in a fire.

The National Building Code, for example, requires that exterior doors to dwellings “be openable from the inside without requiring keys, special devices, or specialized knowledge of the door opening mechanism.” The National Fire Code (intended to be applied to existing buildings) also requires that egress doors (i.e. those leading outside) be openable from the inside without the use of keys.

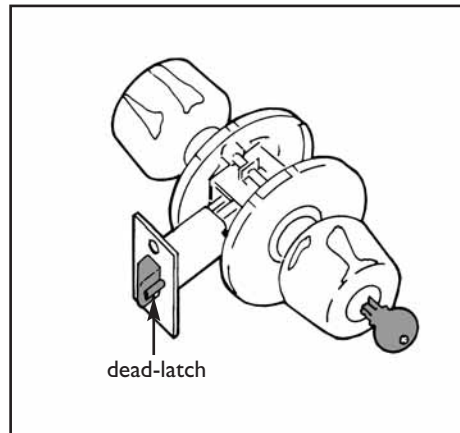

Figure 11 Key-in-lock with dead-latch plunger.

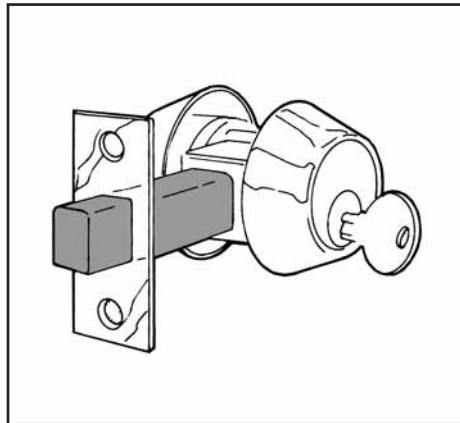

Figure 12 A double-cylinder horizontal deadbolt.

While a double-cylinder deadbolt lock provides superior security in the event that the door glass is broken, its safety disadvantage makes it unacceptable for use in houses. There is simply no time to search for misplaced keys or to fumble with unfamiliar mechanisms in a fire or other emergency. It is much safer to replace the door glass or sidelights within reach of the lock with burglar-resistant glass or to protect the glass with a grill.

Other alternatives are to install a window alarm, or an unkeyed auxiliary lock out of reach of anyone trying to gain entry by breaking the glass.



Figure 13 Breaking the glass will not help a burglar if the auxiliary lock is out of reach.

Like the latch of a spring-latch lock, the bolt of a horizontal deadbolt extends horizontally to engage the strike plate on the door jamb. Although it provides better security than the spring-latch, it may still be possible to pry the door and frame apart to free the bolt from the strike plate, particularly if the throw is limited (see Figure 12).

This is also the principal weakness of the mortise lock, which is set in a recess (mortise) in the edge of the door. It combines the features of the spring-latch and horizontal deadbolt.

To satisfy code provisions, the horizontal deadbolt must be operable from the inside without using a key, and the deadbolt throw must be at least 25 mm (1 in.).

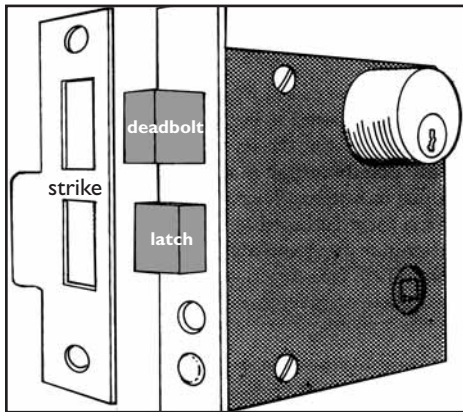

Figure 14 Combination deadbolt and spring-latch mortise lock.

There is one lock that affords excellent protection against this manoeuvre: the vertical deadbolt.

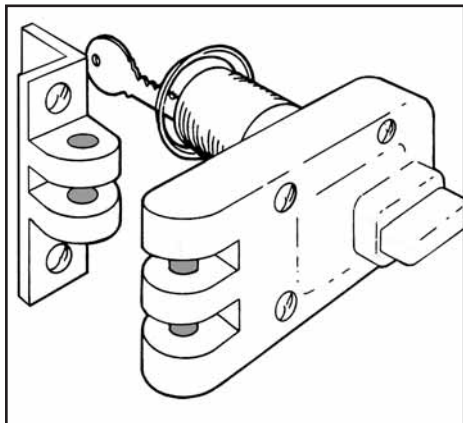

Figure 15 Single cylinder vertical deadbolt.

Its two vertical bolts grip the eyeholes or sockets of the specially designed strike to create a firm bond between the door and jamb. Like most locks, a professional can pick it, but few burglars have the skill or the time to do this.

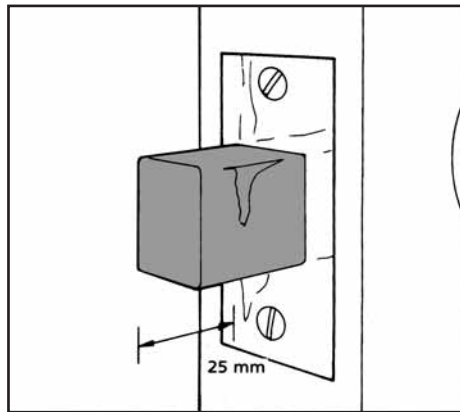

Figure 16 Deadbolts should have a 25 mm (1 in.) throw.

For even greater security, install the lock with carriage mounting bolts¹ in place of the screws that come with the lock, and use long screws to mount the strike plate.

When selecting a horizontal deadbolt lock, ensure that:

- *the horizontal throw is at least 25 mm (1 in.).*
- *at full extension, part of the bolt remains in the lock.*
- *the body of the lock is made of solid steel, brass or bronze (die-cast materials can fracture on impact).*
- *it has a solid or hardened free-turning ring or bevelled cylinder housing to protect the cylinder from being twisted off with vise grips or a pipe wrench.*
- *the cylinder has at least five pins.*
- *it can be unlocked from the inside without keys.*

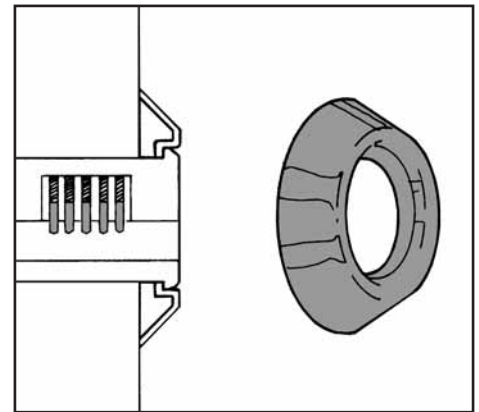

Figure 17 A bevelled ring protects the lock cylinder from being twisted off. Choose a lock with a five-pin cylinder.

Auxiliary locks can easily be installed on solid-core and hollow wooden doors. Mount the lock at least 200–250 mm (8–10 in.) from the door handle to avoid weakening the wood. For even greater strength, use a metal escutcheon plate to reinforce the wood in the area of the lock.

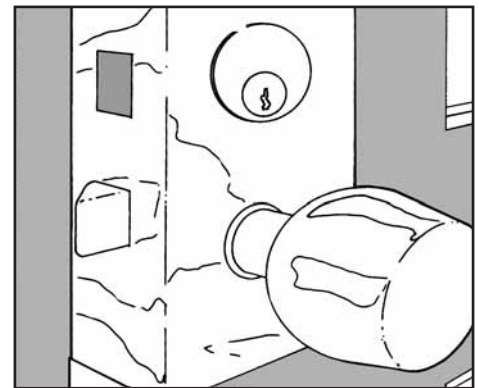

Figure 18 On a wooden door, a metal escutcheon plate helps reinforce the wood around the lock.

¹ Consult a locksmith before making this modification. The holes in some locks cannot be enlarged to accommodate carriage bolts without damage to the internal mechanism.

In the case of steel doors, it is probably best to leave the installation of locks to a qualified locksmith who has the tools required to cut through the metal sheathing.

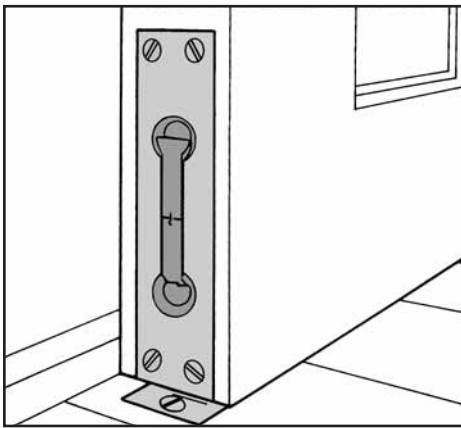

Figure 19 Detail of flush bolt mounted on inactive hinge of French doors.

When it comes to locks, the bottom line is this: if you don't have some form of deadbolt lock on each exterior door, your home is at risk. Doors that can be accessed through a garage, greenhouse, solarium or basement should be treated as exterior doors.

Remember, too, that locks can only be effective if people use them.

Doors that open outward should have non-removable hinge pins or other protective measures to resist forced entry, as previously described. The inactive leaf should be fitted at the top and bottom with heavy-duty bolts having an engagement of at least 15 mm (5/8 in.).

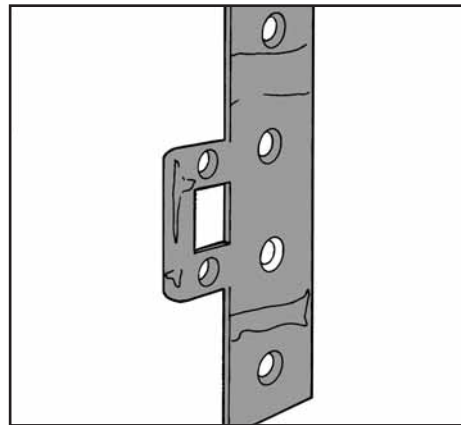

Figure 20 High-security strike plate.

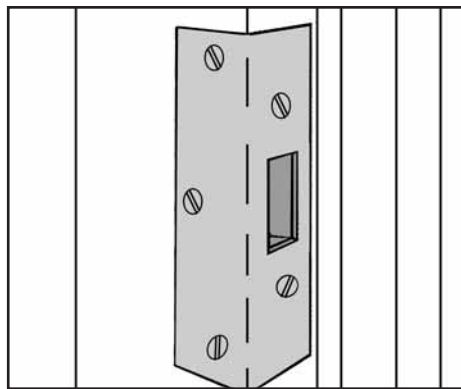

Figure 21 Homemade strike plate.

Other door hardware

Strike plates are the flat metal pieces that are mounted on the jamb of the door frame to receive the bolt or latch. In most cases, good quality strike plates do not come with the lock you buy and must be purchased separately from a locksmith. A wrap-around strike plate fastened in two directions with offset screws is especially useful where there are sidelights that prevent the use of long fasteners.

Strike plates for burglar-resistant doors should be fastened to wood door frames with screws that penetrate at least 30 mm (1 1/4 in.) into solid wood. In the case of steel frames, at least 10 mm (3/8 in.) No. 8 machine screws should be used.

For greater security, a strike box can be used in place of a strike plate. Long screws inserted through the bottom of the box will penetrate deep into the wood of the door frame.

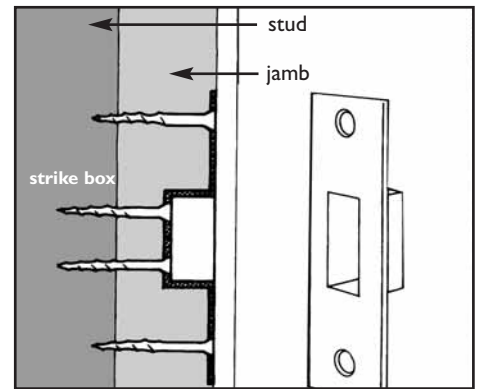

Figure 22 Strike box.

Optical viewers allow you to see who is at the door before it is opened.

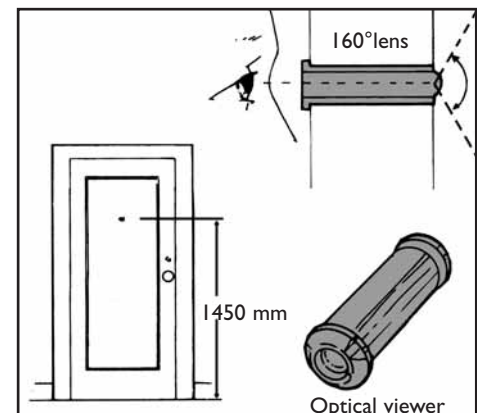

Figure 23 Optical viewers allow residents to see callers without opening the door.

About Your House

How to Lock Out Crime: Home Security—Doors

If the main entrance door has no sidelight or viewing panel, it should be equipped with a door viewer.

Door viewers should have at least a 160-degree field of view. The doorway should also be well-lighted so you can clearly see who is there.

Door chains let you speak to a visitor without completely unfastening the door, but most door chains can be forced by even a slightly built intruder. Even those with locks are easily overcome with simple tools or brute force. For this reason, many police departments do not recommend their use.

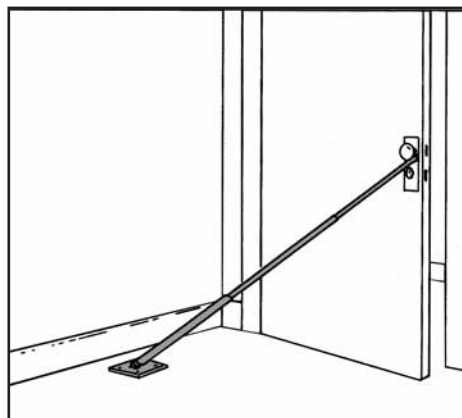

Figure 24 Floor-mounted retractable door stop.

You should not rely on a door chain for security. A floor-mounted, retractable doorstop is more effective.

Other burglar-resistant door assemblies

Door assemblies not described in this fact sheet, including alternative hardware and fasteners, can also achieve acceptable levels of security. These alternative designs can be evaluated against the “Test Methods for Security of Swinging Door Assemblies” (ASTM F 476), published by the American Society for Testing and Materials. Door frames and hardware having a security level of at least Grade 10 under the standard are considered acceptable for residences.

The fact sheets in the **How To Lock Out Crime** series describe various specific actions you can take to make your home less vulnerable.

To find more About Your House fact sheets plus a wide variety of information products, visit our website at www.cmhc.ca. You can also reach us by telephone at 1-800-668-2642 or by fax at 1-800-245-9274.

Free Publications About Your House *fact sheets*

How to Lock Out Crime Series:

<i>Home Security 101</i>	Order No. 65527
<i>Home Security—Exterior</i>	Order No. 65529
<i>Home Security—Alarms</i>	Order No. 65531
<i>Home Security—Windows</i>	Order No. 65535
<i>Home Security—Patio Doors</i>	Order No. 65537
<i>Home Security—Common Sense</i>	Order No. 65539

Other publications by CMHC

<i>Hiring a Contractor</i>	Order No. 62277
<i>Before You Start Your Renovation – Windows and Doors</i>	Order No. 62256
<i>About Your Apartment: Improving Your Security and Safety</i>	Order No. 65041

©2007, Canada Mortgage and Housing Corporation
Printed in Canada
Produced by CMHC

10-10-07

Although this information product reflects housing experts' current knowledge, it is provided for general information purposes only. Any reliance or action taken based on the information, materials and techniques described are the responsibility of the user. Readers are advised to consult appropriate professional resources to determine what is safe and suitable in their particular case. Canada Mortgage and Housing Corporation assumes no responsibility for any consequence arising from use of the information, materials and techniques described.