

The CROWSNEST

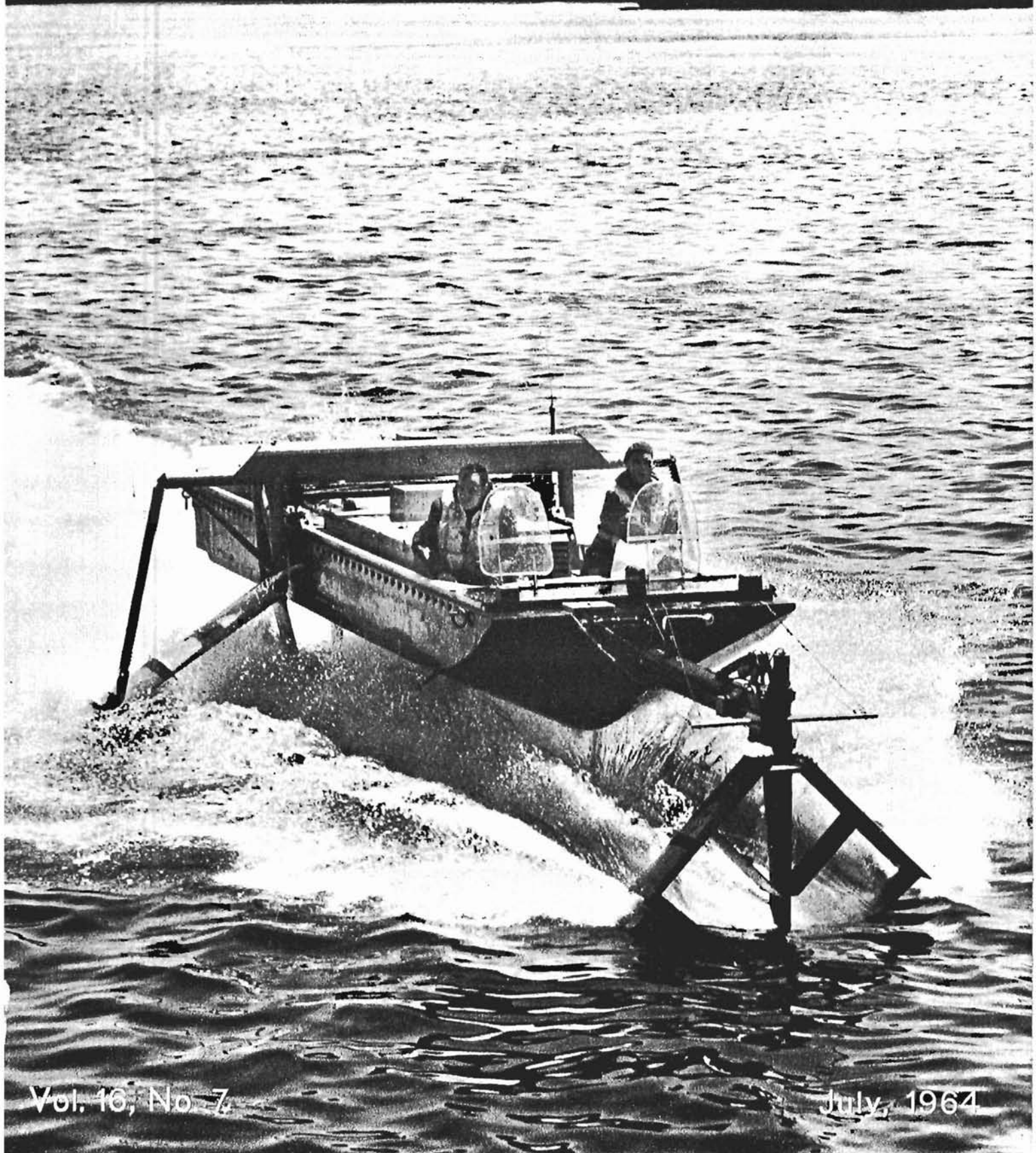

Vol. 16, No. 7

July, 1964



235

The CROWSNEST

Vol. 16 No. 7

THE ROYAL CANADIAN NAVY'S MAGAZINE

JULY 1964

CONTENTS

	Page
<i>RCN News Review</i>	2
<i>Hydrofoils</i>	5
<i>Officers and Men</i>	12
<i>Q-Ship Captain (Part Two)</i>	14
<i>Afloat and Ashore</i>	17
<i>Long Way Round (Part Three)</i>	19
<i>Here and There</i>	21
<i>Books for the Sailor</i>	23
<i>The Navy Plays</i>	25
<i>Science and the Navy</i>	26
<i>Retirements</i>	27
<i>Naval Lore Corner No. 128</i>	<i>Inside Back Cover</i>

LADY OF THE MONTH

All 14 destroyer escorts of the St. Laurent and Restigouche classes have had their portraits appear inside the front cover of this magazine as "Ladies of the Month", with a single exception—HMCS *Chaudiere*. This situation is herewith remedied, although she has not been entirely neglected and has appeared as "cover girl".

The *Chaudiere*, the last of the seven Restigouche class DDEs to be commissioned, was laid down at Halifax Shipyards on July 30, 1953, launched on Nov. 13, 1957, and commissioned on Nov. 14, 1959.

Based at Halifax, she has inherited, along with her sister ships of the Fifth Canadian Escort Squadron, the insignia of the famous Barber Pole Brigade of the North Atlantic convoy lanes. (DNS-32271)

Negative numbers of RCN photographs reproduced in The Crowsnest are included with the caption for the benefit of persons wishing to obtain prints of the photos.

This they may do by sending an order to the Naval Secretary, Naval Headquarters, Ottawa, attention Directorate of Naval Photography, quoting the negative number of the photograph, giving the size and finish required, and enclosing a money order for the full amount, payable to the Receiver General of Canada.

Sizes, finish and the National Defence standardized prices, follow:

4 x 5 (or smaller) glossy finish only ..	\$.10
6½ x 8½ glossy finish only40
8 x 10 glossy or matte finish50
11 x 14 matte finish only	1.00
16 x 20 " " "	3.00
20 x 24 " " "	4.00
30 x 40 " " "	8.00

SUBSCRIPTION RATE

The *Crowsnest* may be subscribed for at the rate of \$2 a year; outside of North America, \$3. Orders, accompanied by cheque or money order payable to the Receiver General of Canada, should be sent to:

THE QUEEN'S PRINTER,
Department of Public Printing
and Stationery,
OTTAWA, Ontario

Communications, other than those relating to subscriptions, should be addressed to:

EDITOR,
The *Crowsnest*,
Naval Headquarters,
OTTAWA, Ontario.

The Cover—The research hydrofoil craft, *Rx*, designed and built by the Defence Research Board's Naval Research Establishment in Dartmouth, N.S., was a star performer on Navy Day in Halifax on July 22. The *Rx* was fitted with a quarter-scale hydrofoil configuration of the kind envisaged for the FHE-400 fast hydrofoil escort discussed in this issue.—NRE Photo by W. R. Carty



RCN News Review

Some of the RCN's warships have had helicopter hangars and landing platforms installed on their quarterdecks. Others, like HMCS Saskatchewan, are satisfied with nothing less than the British Columbia Legislative Building. The picture was taken by Jim Ryan, ex-Navy photographer, in Victoria's Inner Harbour during the Spring Daffodil Festival. (Courtesy Ryans Brothers Photos, Victoria)

CNS Retires At End of July

The announced retirement of Vice-Admiral H. S. Rayner, DSC and Bar, CD, as Chief of the Naval Staff on July 20, at the conclusion of his four-year term in that position coincides with the reorganization of National Defence Headquarters. Admiral Rayner is the Royal Canadian Navy's last Chief of the Naval Staff.

Also disappearing from the scene, after 22 years of existence, is the Naval Board of Canada, established in 1942 to cope with the sudden growth of the RCN to a major fighting force. Thus during July, there will be hauled down symbolically the personal flag of Admiral Rayner and the flag of the Naval Board of Canada.

The armed services will be headed by a single Chief of Defence Staff and each of the functional branch chiefs serving under him will have tri-service responsibility.

Chosen for the top position of Chief of Defence Staff has been Air Chief Marshal Frank R. Millar, CBE, CD, present Chairman, Chiefs of Staff, and a former Deputy Minister of National Defence.

The Navy will be represented on the new Defence Staff by Rear-Admiral K. L. Dyer, DSC, CD, who will become Chief of Personnel and will be Acting

Chief of the Naval Staff until the enabling legislation has been proclaimed. On becoming Chief of Personnel, he will be promoted to the rank of vice-admiral. Commodore R. P. Weland, DSC and Bar, CD, was appointed Acting Vice-Chief of the Naval Staff for any interim period.

Tattoo Planned For Centennial

The Department of National Defence will participate actively and extensively in Canada's Centennial Celebrations in

1967. Its main contribution will be the Canadian Armed Forces tattoo which will tour Canada from coast to coast during the summer of 1967, according to an announcement by Hon. Lucien Cardin, Associate Minister of National Defence.

The tattoo, an historical pageant featuring martial music, will visit most major cities and a number of smaller communities during its five-month itinerary and is expected to be one of the feature attractions at Expo '67 in Montreal.

The Department and the Centennial Commission will work in close association with each other in the planning of the tattoo, which should be one of the most colourful highlights of the centennial year.

Keel of Second Submarine Laid

The keel-laying of the second of three Oberon class submarines being purchased for the RCN in Britain took place June 18 at HM Dockyard, Chatham, Kent.

Designated SS73 until she is named *Onondaga* at her launching next year, this submarine will be the 54th to be built in Chatham Dockyard since submarines were first built there in 1907, and is the first to be built incorporating Canadian design considerations from the keel up.

Unkind Words for Canadian Food

The aircraft carrier *Bonaventure* paid an informal visit to Toulon, France, in February before the Cyprus crisis resulted in her sailing from Halifax to the Mediterranean with military aid for the Canadian contingent.

In his report of proceedings, Captain R. W. Timbrell, the *Bonnies'* commanding officer, wrote of Toulon in part as follows:

"Forty girls from a local orphanage were entertained at a party in A hangar during the afternoon of February 13. After consuming many glasses of cola, eating large quantities of cake, cookies and ice cream, not to add several chocolate bars, one little girl of approximately eight years stated she 'did not consider Canadian food palatable'."

The first of the three submarines purchased from Britain by Canada was HMCS *Ojibwa*, which was launched at Chatham in February this year and is to be commissioned in the RCN following her scheduled completion in September 1965. The third boat, the *Okanagan*, will have her keel laid at Chatham next year.

The keel-laying ceremony is traditionally carried out by wives of shipbuilding staffs, and the *Onondaga's* was presided over by Mrs. I. L. T. Hogg, wife of Rear-Admiral I. L. T. Hogg, Admiral Superintendent of HM Dockyard, Chatham.

Canadian wives taking part in the ceremony were Mrs. Joan Finlay, wife of Lt. Ferguson Finlay, RCN; Mrs. K. Bowness, wife of George Bowness, of Ottawa and Barrow-on-Furness, and Mrs. Rose Fitzgerald, wife of Lt.-Cdr. J. O. Fitzgerald, RCN. Lt. Finlay and Mr. Bowness are Canadian naval technical representatives at Chatham for the Canadian submarine program, and Lt.-Cdr. Fitzgerald is standing by the *Ojibwa*.

Medical Trade Structure Revised

A revised regular force medical trade structure has been established within the Canadian Forces Medical Service (CFMS), effective last May 7. The trade specifications are identical in all three services. These are outlined in the CFMS Trades Manual (1964), compiled by the Surgeon General, which is being distributed.

The seven trades incorporated in the new structure, together with their trade group and pay level are:

Medical Assistant (MA), 1, 2, 3Y and 4; Nursing Assistant (NG), 1, 2, and 3X; Operating Room Assistant, 4; Hygiene Technician (HK), 3X, 4; X-Ray Technician (XT), 3X, 4; Laboratory Technician (LB), 3Y, 4, and Biosciences Technician (BT), 3Y, 4.

The trade of Pharmacist (PM) has been retained temporarily but no further entries or transfers into it will be permitted.

Certain of the trades, Medical Assistant, Hygiene Technician and Biosciences Technician, will be open to men only. The trade of Nursing Assistant applies only to wrens. The remaining trades—Operating Room Assistant, X-Ray Technician and Laboratory Technician—are open to both men and wrens.

Under the new structure, all Medical Assistants are retaining the same trade and designator, wrens serving as Medical Aides are being transferred to

Nursing Assistant and all Operating Room Assistants are retaining the same trade and designator. Similar transfers are being made between the other former trades and the corresponding new ones.

The primary duties of the Biosciences Technician, a trade in which there is a limited requirement for men, are in the field of applied physiology, including research in environmental and thermal stress, human engineering and survival. Retention in this trade will be by selection. Those not chosen will qualify for transfer to Medical Assistant.

RCN personnel will continue to compete only with one another for promotion, advancement and course selection.

Further particulars of the medical trade structure changes may be found in Cangen 158 and in BRCN 113 (4) (60) as amended.

Ships Take Part In Festival

Four ships of the Pacific Command, the *Fraser*, *Mackenzie*, *Margaree* and *Qu'Appelle*, sailed from Esquimalt on June 15 for 10 days of exercises in local waters and then proceeded to

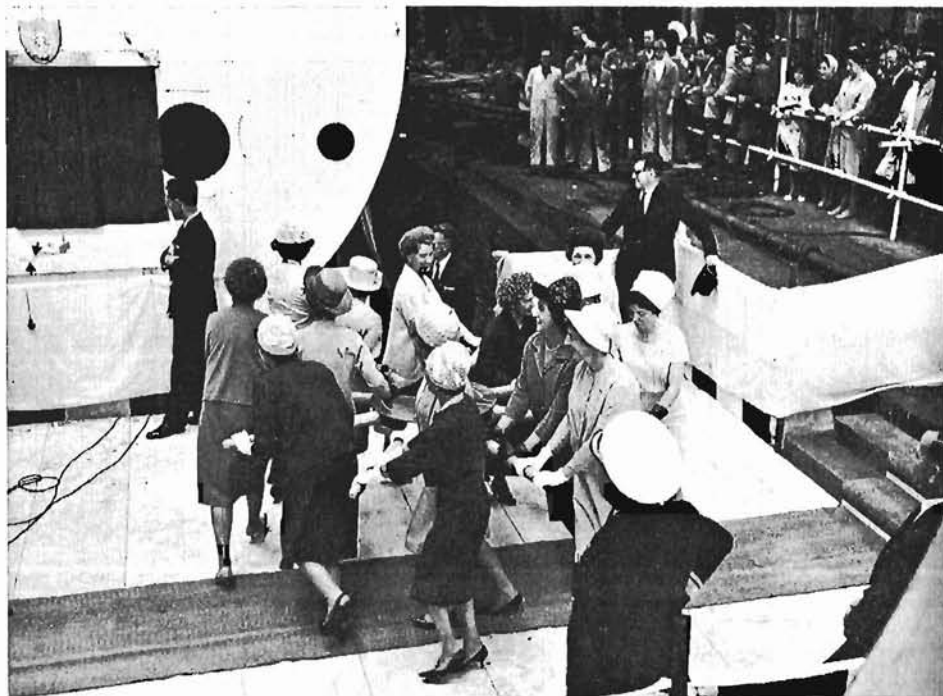

An old Chatham Dockyard tradition was observed when wives of the men in charge of the construction of the Oberon class submarine *Onondaga* for the Royal Canadian Navy manned a capstan that moved a prefabricated section of the hull into place on its construction berth. Taking part were 11 wives of senior dockyard officers and three Canadian wives. The latter were, from left in lower picture, Mrs. K. Bowness, wife of George Bowness; Mrs. Rose Fitzgerald, wife of Lt.-Cdr. J. O. Fitzgerald, RCN, and Mrs. Joan Finlay, wife of Lt. Ferguson Finlay, RCN. (508-149; 508-153)

Vancouver to participate in the mainland city's Maritime Festival.

Also taking part in the exercises was the submarine *Grilse*, which had been at Portland, Oregon, from June 10 to 14, representing the RCN at the Portland Rose Festival. The *Grilse* returned to Esquimalt on June 20.

The destroyer escorts, on arriving at Vancouver, anchored in English Bay on the early afternoon of June 25. All four ships were illuminated that night, and the following day went into Vancouver harbour. Members of the ships' companies participated in festival activities, including the parade through Vancouver on June 26 and "open house" programs over the weekend. Plans for the Vancouver visit were co-ordinated by Captain John Gray, Principal Naval Overseer, Vancouver.

Sailing in HMCS *Fraser* was Captain R. J. Pickford, recently appointed Commander Second Canadian Escort Squadron, who succeeded Captain G. H. Hayes.

The four ships returned to Esquimalt on June 29.

77 Graduate From Royal Roads

Seventy-seven officer cadets of the three armed forces, nearly half of them from Ontario, graduated from the Canadian Services College, *Royal Roads*, on May 29 in a colourful and impressive graduation ceremony attended by some 1,500 guests. The bands of HMCS *Naden* and the First Battalion Queen's Own Rifles of Canada, provided music for the marching manoeuvres executed by the cadet wing.

The inspecting officer was Major-General Robert P. Rothschild, MBE, CD, Quartermaster General of the Canadian Army.

Following the formal inspection, the march-past and the address by the inspecting officer, another highlight of the program was the presentation of major awards to officer cadets who had distinguished themselves by their academic, sports and military achievements.

The graduation marked the end of an activity-packed week which started the previous Sunday with a wing parade in honour of ex-cadets of the services college. On Wednesday there was a full dress rehearsal of the graduation ceremony. The next day the college held the "Parents Day" portion of the graduation program, at which there was a gymnastics display and the presentation of various academic and sports awards.

On Friday evening the graduation ball was held on the college quarterdeck in the Grant Block. The *Naden* dance orchestra supplied the music.

The 34 Air Force, 26 Army and 17 Navy officer cadets, after summer training, will attend the Royal Military College of Canada in Kingston, Ont., for the next two years. On successful completion of their studies there, they will graduate with university degrees and commissions in their respective services.

Commissions for 33 Chief and POs

Thirty-three chief petty officers and petty officers of the Royal Canadian Navy have been promoted to the rank of commissioned officer after successful completion of qualifying courses. They will take up their appointments in ships and naval establishments later this year.

The newly-commissioned officers are: William J. Walsh, Patrick Mackinnon, Thomas A. Miller, William F. Hooper, Leslie P. Graydon, Geoffrey E. Embley, Thomas B. Edwards, Richard C. Duiven, James D. Cummings, Ronald P. Coster, Michael B. Forward.

Ronald Bosquet, Gordon H. Wings, Peter E. Hill, Daniel C. Spicer, Bruce P. Beacock, Andrew J. Black, William H. Taylor, James A. McCullough, Thomas W. Gardner, Hugh A. Millman, Ronald W. Quick.

James E. Wright, John Wandler, Clive D. Pattison, Lawrence W. Larson, Henry L. Clarkson, Sydney D. Bryant, Frederick W. Hoyle, Ernest R. Mueller, Robert K. O'Neil, Kenneth O. MacLean, Graham H. Sherwood.

British Envoy Visits West Coast

His Excellency Sir Henry Lintott, British High Commissioner in Canada, visited the Pacific Command of the RCN in May.

Accompanied by N. S. Belam, principal British Trade Commissioner in Vancouver, His Excellency toured HMC Dockyard and visited the destroyer escort *Mackenzie*. The visitors were accompanied by Rear-Admiral W. M. Landymore, Flag Officer Pacific Coast, and Commodore H. A. Winnett, Commodore Superintendent Pacific Coast.

Later the party visited the British Columbia Maritime Museum.



Naval communicators representing the RCN communications branch at the annual NATO Naval Communications Training Competition in HMS *Mercury*, Petersfield, Hampshire, England in early June were: AB Henry Witter, HMCS *Jonquiere*, left, who finished fourth in flashing; AB Ronald Keifert, Naval Radio Station, Frobisher Bay, N.W.T., who came fifth in radio reception and Ord. Sea. Marvin Lane, HMCS *Naden*, who came fourth in teletype. Elimination trials conducted in HMCS *Cornwallis* in May resulted in the above men representing the RCN. The closeness of the contest can be gauged by the fact that the difference in marks between first and fourth places in flashing was only 1.6 per cent while a mere .075 per cent separated first and fifth places in radio reception. Twenty-two contestants representing the navies of seven NATO countries participated. Competitors had to have less than six years' seniority in order to participate. (E-77101)

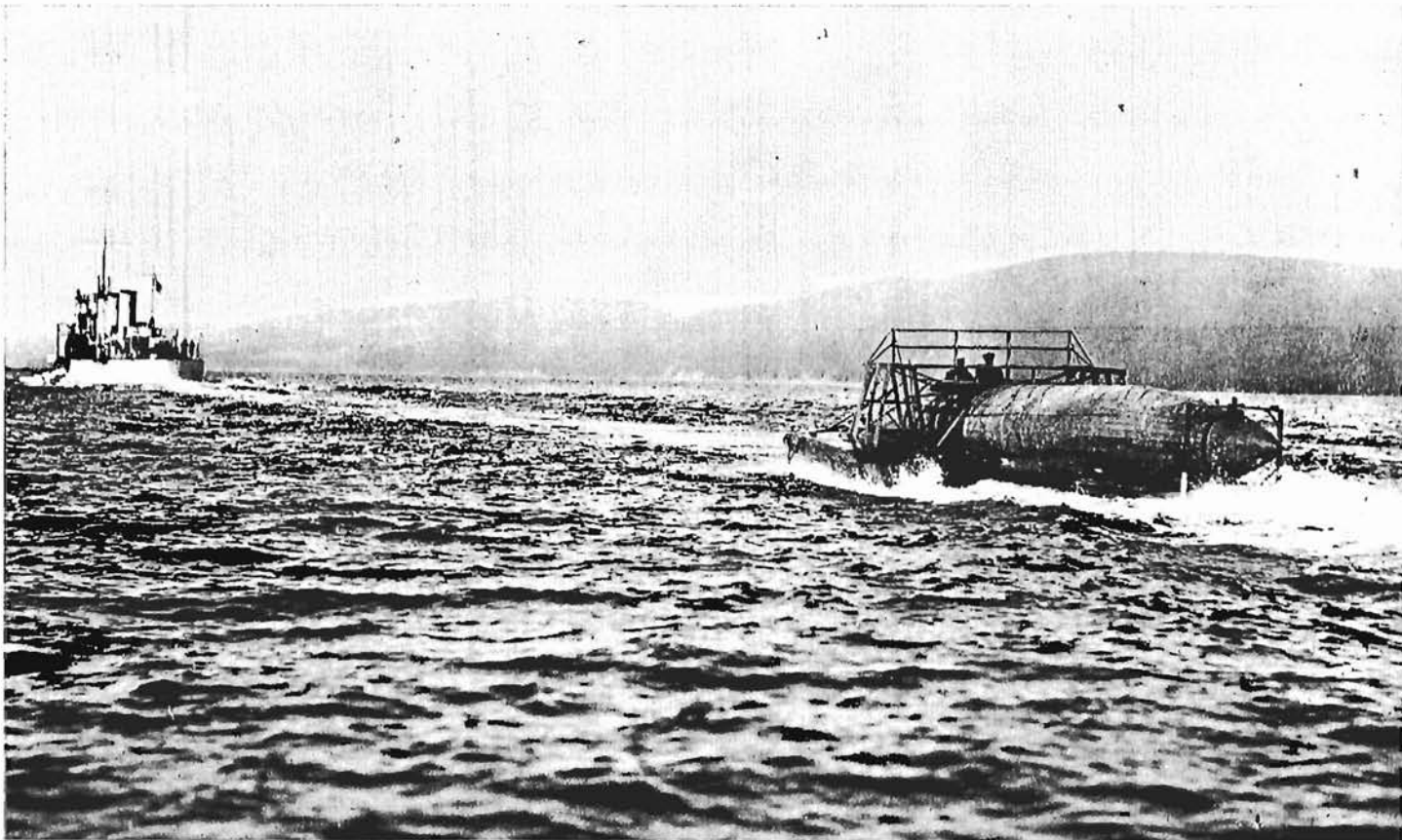

The Royal Canadian Navy's interest in hydrofoil development goes back to the years just after the First World War. HMCS Patriot, a destroyer, is shown towing at 14 knots the HD-4, a hydrofoil craft designed by Dr. Alexander Graham Bell and F. W. (Casey) Baldwin, on the Bras d'Or Lakes, near Baddeck, N.S. The HD-4 established a 60-knot speed record that stood for a generation. (CN-2947)

HYDROFOILS

THE HYDROFOIL CRAFT is, quite literally, a ship with wings. These wings, or foils as they are called, operate on the same basic principles of fluid dynamics as do the wings of an airplane, the only differences being due to the fact that their working fluid is water, not air.

There is nothing novel in this concept. Marine craft using water wings, or hydrofoils, to support them have been with us in one form or another for more than 50 years. The Wright brothers experimented with such a craft as early as 1907 and it is interesting, though idle, to speculate what might have happened had they decided to devote their energies to this instead of to the heavier-than-air flying machine.

The early history of hydrofoil craft has been dealt with very adequately in the technical literature, but the early work of Alexander Graham Bell and F. W. (Casey) Baldwin is considered worthy of mention here since, firstly, it was Canadian and secondly, it culmin-

**C. Beaumont Lewis,
BSc, DCAe, APRAeS.**

*Deputy Director
of
Hydrofoil Development
Royal Canadian Navy*

ated in a craft, the HD-4, which is reported to have exceeded 60 knots. This was in 1919, and this was not bettered until 1953, when the American Grumman XCH-4 attained speeds in excess of 70 knots. Both these craft were powered by reciprocating aircraft engines driving air propellers.

Capabilities

THE HYDROFOIL CRAFT is capable of operation at slow speeds as a normal displacement vessel. It is handicapped, in calm water at least, by having to drag along its foil system. In

rough water these appendages are made to work their passage, for they provide powerful damping forces, even at very low speeds or hove to, which greatly reduce ship motion and give the hydrofoil craft seakeeping qualities comparable with vessels of very much greater tonnage.

At higher speeds—over 30 knots—whereas the conventional hull runs into wave-drag humps and its operation becomes hopelessly uneconomic, the hydrofoil boat really comes into its own. It is able to take off from the surface of the sea and fly with its hull clear of the water and totally supported by the hydrodynamic lift of its foils. It is thus able to attain speeds of 60 knots or more. However, it runs into problems of its own at these higher speeds, namely cavitation and ventilation, of which more will be said later. At present these problems limit its maximum speed in calm water to about 60 knots.

The seakeeping ability of larger (i.e. 200 to 500 tons), practical, naval hy-

drofoil craft has yet to be finally determined, because such craft have yet to be built and present knowledge is derived from extrapolations from tests of smaller craft and computer simulations. However, displacement craft have been made with encouraging results.

Weight saving is of vital importance in the design of hydrofoil craft if useful payload and range are to be achieved. For this reason the designer is forced to adopt, and adapt, the techniques of the aircraft designer rather than those of the naval architect and marine engineer. Indeed, it is the development by the aircraft industry of efficient materials and structures, and high-power/light-weight propulsion units which have made the design of large hydrofoil craft feasible today. The hydrofoil designer still has to remember that his structures have to resist the pounding of a fluid 900 times denser than air and immeasurably more corrosive. It also has to be habitable for

several days rather than for several hours. He cannot afford to ignore the experience of the naval architect and the marine engineer if his boat is to remain in one piece.

Configuration

THERE IS a so-called "conventional" configuration in which the boat has its foils disposed somewhat like those of a modern airplane. (Figure 1). The weight distribution is about 70 per cent on the front foils and 30 per cent on the rear foils. In a larger craft this arrangement complicates somewhat the internal arrangement of machinery, fuel tanks, living spaces, etc.

The next configuration uses the "tandem" arrangement of foils and this is used by the well-known Supramar boats. The weight distribution is roughly 50-50 on front and rear foils. This configuration permits a wide CG

travel and consequent flexibility of internal arrangement. It also has the advantage of equal span foils which can usually be confined to an overall width of little more than the beam of the hull. However, this configuration has some structural disadvantages.

Finally there is the "canard" configuration adopted for the Canadian FHE-400. In this, the weight distribution is roughly 10 per cent on the front foils and 90 per cent on the rear foil unit. In a boat designed for rough water operation this configuration permits very fine lines forward, thus reducing impact loads, and also makes for good internal arrangement and engine installation. It also can be given good stability in following seas.

Type of Foil System

HYDROFOIL BOATS are also classified according to the type of foil system used. In order to stabilize

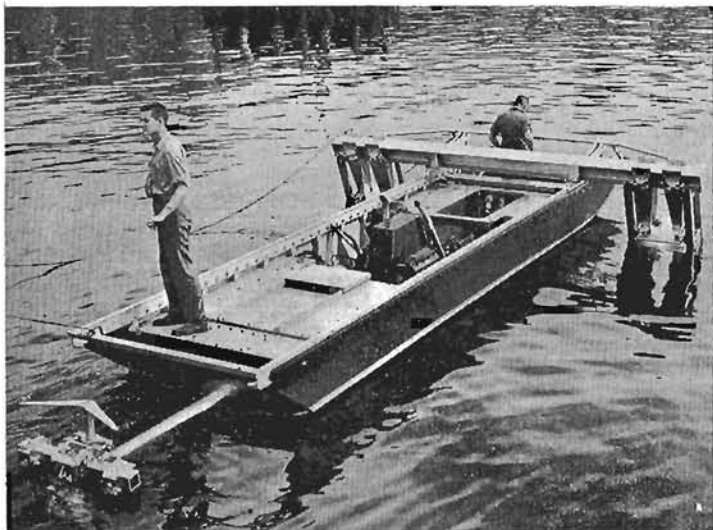

Three of the experimental predecessors of the FHE 400 are illustrated. At the upper left is the *Massawippi*, designed by naval architect Philip L. Rhodes, of New York, for Cdr. D. M. Hodgson, RCNR, of Montreal, who proposed an attempt on the world's water-speed record. The *Massawippi* project was taken over by Defence Research Board and the craft, built for the Naval Research Establishment, Dartmouth, attained speeds of up to 55 knots. The next craft, the *Bras d'Or*, built by Saunders-Roe in Britain and brought to Canada on board the *Bonaventure* in early 1957, is 75 feet long, compared to 45 feet for the *Massawippi*. Much useful knowledge has been gleaned from her operation. The *Rx*, shown at lower left, is more like a barge than a boat. She is used to test various foil designs.

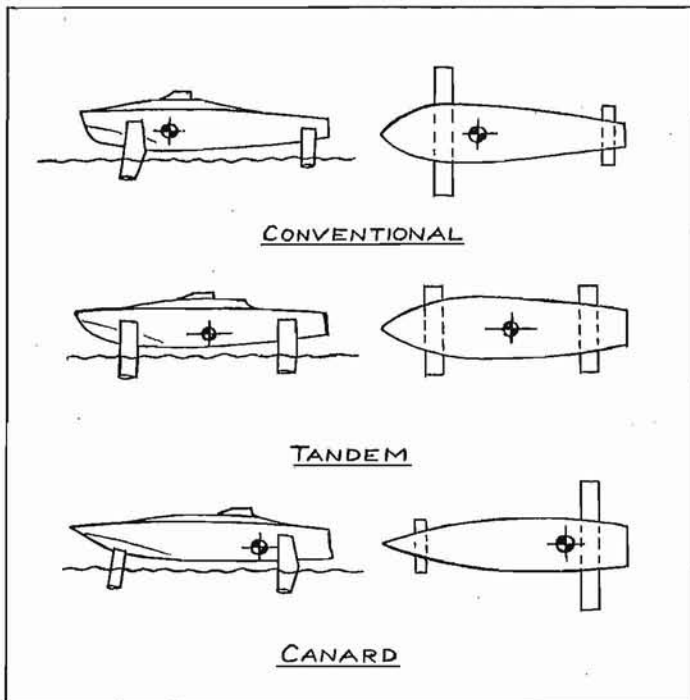

Figure 1

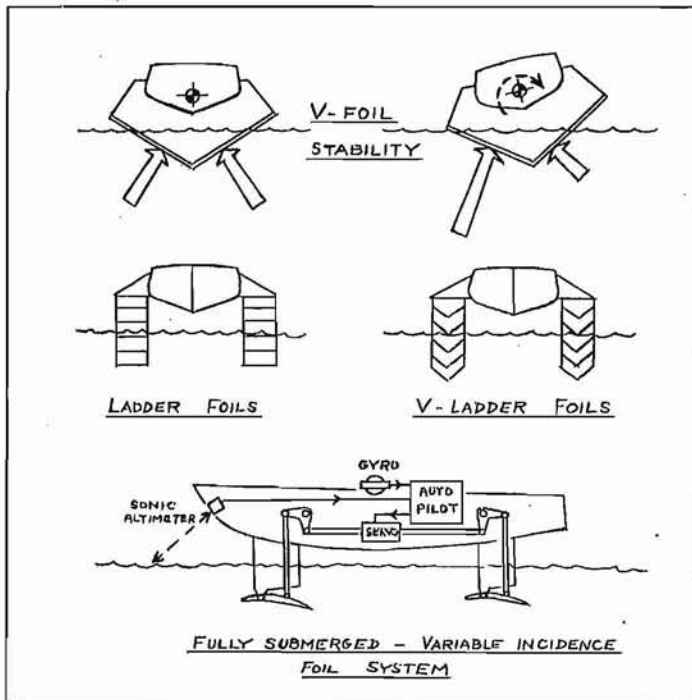

Figure 2

a boat, it is necessary to provide restoring forces and couples by varying the lift of the foils. This is generally done in one of four ways:

First, area-stabilized foils. These are necessarily surface-piercing foils and the lift is varied by immersing more or less of the foil in the water. Within this classification comes the V-foil, the ladder-foil system and combinations of the two. (Figure 2).

Secondly, there are the incidence-stabilized fully submerged foil systems.

These systems vary the lift of the foil as required by changing its incidence. This may be achieved by sensing changes in the boats' attitude and altitude, and providing these as error signals to a feed-back control system which continuously adjusts the incidence of the foils.

Thirdly, the lift may be varied by changing the effective camber of the foil surface by the use of flaps. Here again it is necessary to use an autopilot and powered controls. (Figure 3)

A fourth type is the trim stabilized system, in which the foil remains fixed relative to the hull, but its angle of attack is changed by changes in pitch trim of the craft. Such changes in trim are effected by a "feeler" foil which is sensitive to changes in the sea contour.

In all the foregoing, the foil sections themselves may be classified as:

Sub-cavitating—similar in profile to low speed aerofoils, and designed for speeds or loadings at which cavitation presents no serious problems.

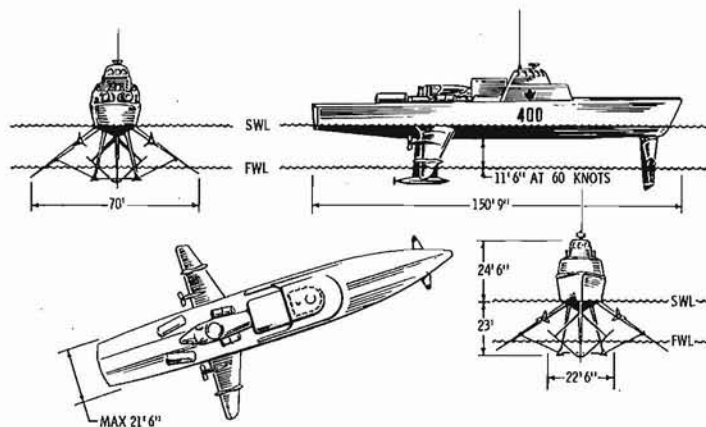
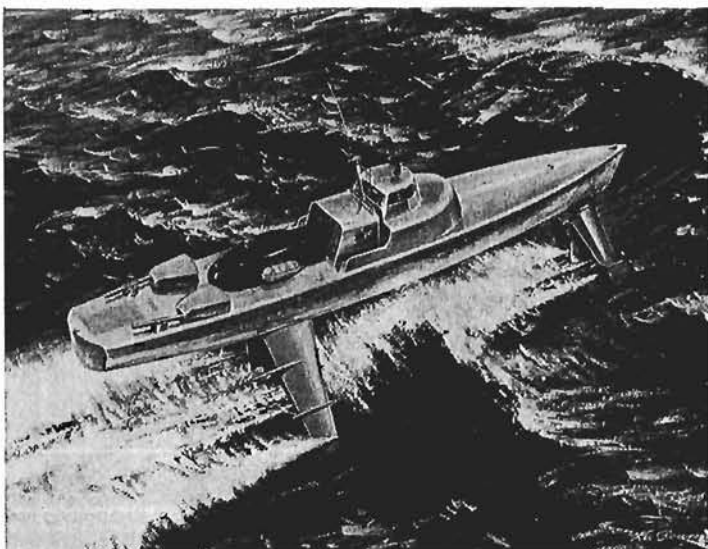

Illustrated in artist's drawings is the RCN prototype of the anti-submarine hydrofoil ship, the FHE 400. The line drawings show that the hull, at high speed, will be lifted 23 feet so that there is an average clearance of 11½ feet between keel and water surface.

Delayed-cavitation—similar in profile to transonic aerofoils, and designed to avoid peak suction in the chordwise pressure distributions and hence to delay the onset of cavitation to much higher speeds.

Super-cavitating—these sections are intended to “live with” cavitation rather than to avoid or delay its onset. They are designed so as to create, at high speeds, a thin continuous cavity at the upper surface extending from near the leading edge to behind the trailing edge. Nearly all their lift is due to the positive water pressure on the lower surface.

Super-ventilating—here again, these sections are intended to “live with” ventilation (i.e., access of air from the free water surface to the foil surface) rather than to use means of preventing it. Access of air to the upper surface is encouraged, and the lower surface of the foil develops lift as a planing surface. (Figure 4)

Response to Wave Systems

HYDROFOIL CRAFT are sometimes classified according to the way in which they respond to major wave systems; that is:

Planforming—the craft is designed so as to have zero response to waves so that it cruises at constant altitude and without pitch, heave, or roll. This ideal can only be approached with very large craft, or in very small waves.

Contouring—the craft is designed so as to have full response to the wave motion and faithfully follow the contours of major waves.

Semi-contouring—the craft has a partial response to wave systems that lies between the two extremes above. Thus, it is designed to ride smoothly through small waves and to have less than full response to big waves. (Figure 5)

The above attempt at a classification of hydrofoil craft forms is really little more than a glossary of some of the terms used in describing them. The forms that have been adopted are many and varied, as in the early days of aircraft design, and no one predominant form has yet evolved. The operational use to which hydrofoil craft are put will determine many things. Whether their bodies will resemble a ship's hull or an aircraft's fuselage, whether they will use air or water propellers or even air or water jets; these things, and many others, will depend on their missions, and on whether they are used on lakes and rivers or on the open seas.

Cavitation and Ventilation

CAVITATION AND VENTILATION are terms that have been used already and perhaps a brief explanation of these phenomena is now in order. Together they represent the major differences between the fluid dynamics of hydrofoils and aerofoils.

Cavitation—For both types of foil, the pressure on the upper surface decreases as speed increases. In the case of the hydrofoil, a point is reached at which the local pressure on the upper surface falls below the local vapour pressure of the water, and the water then boils. This causes bubbles or

“cavities” of vapour to form and seriously disrupt the hydrodynamic forces generated by the foil. The appreciable loss of lift resulting can cause violent heave instability, aggravated by pitching moment changes and hydroelastic effects. Serious drag increases and erosion of the foil surfaces (by water impact when the cavities collapse) also occur.

Pressure distribution over the foil surface is also dependent on angle of attack or lift coefficient and thus cavitation imposes limits on both the speeds and the range of lift coefficient that can be used. In practice, foil loadings are thus limited to about one ton per square foot; this particular ill wind blows some small good in that this provides an effective “fuse” for structural loads on the foils.

Ventilation occurs when there is access by atmospheric air from the free surface of the water to the low pressure regions on the submerged foil or strut surfaces. Flow over these surfaces is then drastically disrupted. This problem besets both fully submerged and surface-piercing foil systems, though more serious in the case of the latter. Designers have attempted to control or inhibit ventilation by the use of “fences” on struts and foils, their optimum locating being determined by cut-and-try methods.

Craft Size

MANY YEARS AGO aircraft designers were plagued by the so-called “square-cube” law. This was based on the fact that lift was supposed

Figure 3

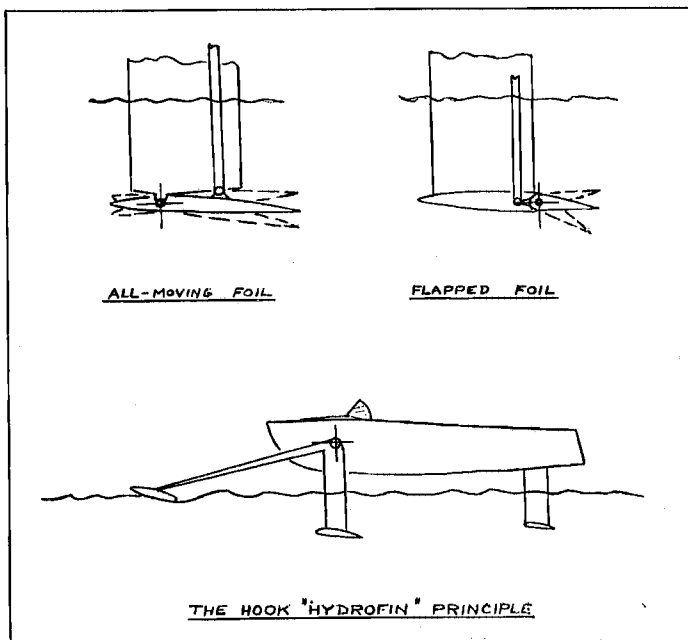
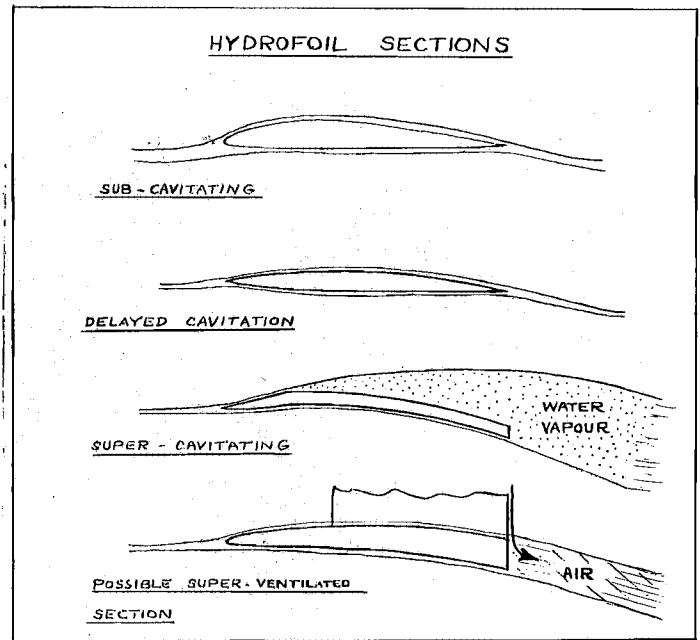

Figure 4



to vary as the square of the linear dimension, whereas the weight was supposed to vary as the cube of the linear dimension. Neither of these suppositions was found to be strictly true, particularly the latter, and designers managed to beat the law by increasing wing loadings (and landing speeds) and getting improved structural efficiency with increasing size.

However, hydrofoil designers have not been so fortunate in shrugging off the "square-cube" law, since cavitation limits foil loadings to about one ton per square foot.

Thus, in spite of all designers can do, the foil weight fraction tends to increase with increasing size. However, hull structure and outfit weight fractions tend to decrease with increasing size, and the fraction of the gross weight taken up by payload and fuel together remains sensibly constant over a wide range of sizes from about 150 to 300 tons.

Above this size, however, the foil system weight fraction increases rapidly, and, in this author's opinion, makes the dream of large foilborne transoceanic cargo or passenger ships quite unrealizable from both the engineering and economic standpoints.

However, small (below 60 tons) hydrofoil craft have for several years operated commercially on carefully selected routes, and larger craft are being built for commercial use by both USSR and USA.

Naval Craft

TURNING NOW to naval craft, it is obviously desirable to work in the most economic size range if this is compatible with other operational requirements.

The factors which will determine the size of a naval hydrofoil craft are, in rough order of importance:—

- (a) seakeeping requirements and habitability
- (b) military load
- (c) range (both foilborne and cruising)
- (d) available power plants.

Other things remaining equal, seakeeping ability increases with size and this factor may well override all others in determining the minimum size of an open-ocean craft for a specific role or roles. Habitability is an important factor, and what is acceptable for an assault landing craft or coastal patrol boat may not be so for an open-ocean ASW craft.

Factors (b) and (c) can obviously be traded one for the other. In the range equation, increasing size has a negligible

effect on propulsive efficiency and specific fuel consumption, and the increase in lift/drag ratio with size is less than for a displacement craft because of relatively increased foil system drag.

Thus, the displacement cruising range for hydrofoil craft between 100 and 300 tons remains approximately 3,000 nautical miles for zero military load. However, as the military load is increased from zero, the range falls rapidly for the smaller craft. The exchange rate for a 100-ton craft is about 100 nm/ton of military load, whereas for a 200-ton craft it is only about 50 nm/ton.

Propulsion Systems

THE PRESENT feasibility of larger hydrofoil craft owes much to the development of "marinized" aircraft gas turbines, which are available today giv-

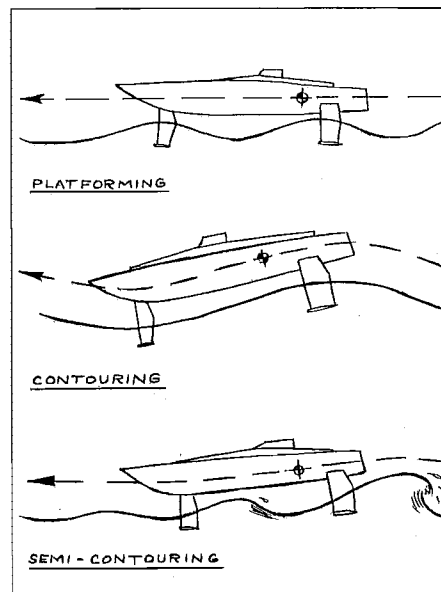

Figure 5

ing power/weight ratios a whole order higher than the best marine diesels, and may soon be available giving up to 25,000 SHP in a single package. Such engines are the obvious choice for foilborne propulsion of the larger hydrofoil craft.

The choice of units for displacement cruising (requiring only a small fraction of the foilborne power) is more difficult in many respects, and will depend greatly on the operational use of the craft. A high-speed troop transport or assault landing craft would probably use a smaller gas turbine for displacement cruising and manoeuvring, whereas an open-ocean convoy protection vessel, which would cruise for long periods at displacement speeds, would probably use diesel engines.

The choice between air propellers, water screws (conventional, variable pitch, or super-cavitating) and water jets is also greatly dependent on the operational use and environment, and subject to the all-pervading considerations of component weights and efficiencies.

The Canadian Role

THE AIM of the Canadian hydrofoil program has been to find the smallest, simplest, and least costly vehicle which can operate with reliability and reasonable comfort in the open ocean and have a high degree of effectiveness in the many phases of anti-submarine warfare and in additional naval roles as appropriate.

The Defence Research Board's interest in hydrofoil research stems from the early work of Graham Bell and "Casey" Baldwin referred to above. Research at the Naval Research Establishment of DRB was originally aimed at developing the potentialities of the Bell-Baldwin ladder-type foil system for application to open-sea operation of naval craft. NRE has been primarily concerned with the development of small craft capable of operation in rough water in the 45-60 knot speed range.

In 1951, NRE took over the five-ton *Massawippi* (R-100), which had originally been designed by a New York naval architect, Philip Rhodes, for an attempt on a water speed record. It has been a very successful craft and was used in trials until a few years ago.

This work led to a series of design studies and model tests for a larger craft capable of open-ocean patrol. This in turn led to a contract being placed with Saunders Roe, England, for design and construction of the 17-ton *Bras d'Or* (R-103) which was delivered to NRE for trials in 1957.

During 1958 and 1959, NRE made a comprehensive study of the hydrofoil craft's potential in ASW.

This was the first serious attempt to synthesize a concept for an ASW hydrofoil system based on the study of both technical and operational factors.

NRE believed that naval applications of hydrofoil craft need no longer be limited to coastal patrol type operators. They suggested that a hydrofoil craft of about 200 tons displacement would be highly effective in many open-ocean ASW roles, and that the relatively low cost of such a system would make it feasible a "small and many" concept offering more operational effectiveness per dollar expended than any other single ASW vehicle.

This led to a contract being placed with the de Havilland Aircraft of Canada

for a comprehensive design study, based on the NRE report, to examine the premises and conclusions in depth and to ascertain the engineering feasibility of the proposed design by means of extensive computer simulation and a model test program.

This work was financed from DDP Development-Sharing Funds, with DRB providing the technical project officer and some of the test facilities and personnel, and it was followed with close interest by the RCN.

This study was aimed at producing preliminary design for a 200-ton vehicle for use primarily in open-ocean ASW roles. Design data was obtained from a comprehensive theoretical and model test program which included:

- (a) development of a special technique for delayed cavitating foil and strut sections.
- (b) hydrodynamic model tests on
 - (i) a small complete model for resistance measurement in calm water and waves at hullborne and take-off speeds, and a qualitative assessment of hullborne seakeeping, (ii) 1/8 scale models of the bow and main foil units for measuring lift, drag, moments and, in the case of the latter model, pressure distribution over the critical regions, (iii) a coupled beam model for measurement of drag and pitch and heave response in waves, (iv) a representative 1/4 scale model of the foil system mounted on the Rx experimental craft at NRE and used for investigations of stability, seakeeping and performance intended primarily to check the validity of the analogue computer simulation of the full scale craft.
- (c) an analogue computer simulation of both the 1/4-scale Rx and the full-scale R200 craft. In many respects this simulator study was the hub of the Phase II design program. This computer study is believed to be the most comprehensive ever made on a hydrofoil craft. The computer was used to simulate the highly non-linear equations of motion of the surface-piercing system in 6 degrees of freedom in sinusoidal seas and random State 5 seas. The simulation took into account the orbital velocities in head, beam, and following seas, partial ventilation of foil and strut elements, unsteady flow hydrodynamics, virtual inertia effects in

waves, and the onset of local cavitation.

This study has produced prediction of craft motions and accelerations in heave, pitch, roll, yaw, side-slip and surge, of foil system loads for rational load analysis and fatigue stress determination, and of maximum and average resistance in regular and random seas.

The Rx craft has been run in regular and random seas of various headings with instrumentation to measure the craft response and the trials sea state. This work has so far shown a reasonably close agreement to exist between experimental and computer results, but some further work is required to acquire a more statistically significant quantity of test data.

Most important of all, perhaps, the computer study has shown (and Rx trials have confirmed) that a surface-piercing foil system can be designed which will be stable on all headings in sea states up to 5 and above.

The Phase I study soon confirmed that something special in the way of foil materials was required if we were to wring the last drop of performance out of a delayed cavitation system and still meet the strength and operational life requirements. At this time the "Maraging" Ni-Co-Mo steels seemed to offer considerable promise, though very scanty design data was then available. The RCN thus embarked upon a separate investigation of high-strength steels and coatings to determine their suitability for hydrofoil and other marine uses.

We now believe that a craft of about 200 tons displacement with the particular foil system developed during the above study will be capable of open-ocean operation in various naval roles.

RCN Hydrofoil Project

THE RCN has made a very thorough technical assessment of the design proposed by the contractor and is now proceeding with the detailed design and construction of a "one-off" development prototype, known officially as the FHE-400.

The aluminum-alloy hull of this craft will be about 150 feet long. Since it seems likely that it will spend by far the greater part of its total time at sea in the "hullborne" mode, the hull lines have been optimized for low displacement resistance and to reduce slamming and wave impact loads. The damping provided by the large fixed surface-piercing foil system gives displacement seakeeping comparable with a much larger ship, and, as we clearly demonstrated by early model tests, this damping results in a surprisingly low rough

water increment of resistance. Thus, although the fixed foils impose a drag penalty in calm water, they really pay for their passage in rough water.

The foil system is of canard configuration, using area-stabilized surface-piercing delayed-cavitation foils of the "V" or "hoop" type. It is a semi-contouring, or partial response, system which does, in fact provide inherent stability and control without the moving parts, sensors, and "autopilots" employed in the USN designs. It had been adequately demonstrated that this system can give good seakeeping in calm water and in modest sized waves. We now have evidence from the comprehensive computer and model test program of the past three years that a fixed, surface-piercing, foil system can be designed to operate successfully on all headings in sea states up to and including SS.5.

Recent work has completely discredited the once widely held view that surface-piercing systems could not perform satisfactorily in certain following-sea conditions, the 3-ton, 1/4-scale Rx can take off and operate successfully on all headings in waves exceeding appreciably a model state 5 sea. The bow foil unit is steerable and provides a rudder for both foilborne and hullborne operation. For low speed manoeuvring the widely separated variable pitch propellers can also be used.

The propulsion system is fairly orthodox and is believed to be well within the state-of-the-art. Separate systems are used for hullborne and foilborne propulsion, the former using a diesel engine and the latter a single large gas turbine. Both systems use "Z" drives through bevel gear boxes located in the hull and in the propeller pods. The displacement propellers are normally out of the water at foilborne speeds.

Considerable attention is being given to the habitability question. The human thresholds of tolerance to ship motion are fuzzy, and it is difficult to predict the reaction of the crew to the foilborne motions indicated by the computer studies of the craft in random seas. Even if these indications are realistic, there are many other factors which we cannot even attempt to simulate. Also, due to the stiff damping action of the foils, the hullborne motions are somewhat unusual.

Living accommodation is not cramped, by submarine or MTB standards, but it will require careful location, and special provisions (such as seat belts) might be required for foilborne operation. Good habitability is essential for crew efficiency, and the crew cannot afford to have their wits dulled by long

periods of hullborne sea-sickness. Every effort will be made to provide the optimum degree of automation for both control of the machinery and for operational control of the craft.

The development prototype craft will be used for extensive engineering trials and for an operational evaluation by the RCN of the usefulness of this type of craft in various ASW roles. For the operational evaluation, the ship will have a representative outfit of fighting equipment. This is being developed concurrently, and will make maximum use of components now existing or in development for other purposes, although system organization and packaging must necessarily be designed specifically for the hydrofoil ship.

The Future

THE SHIP just described is, of course, only one of several hydrofoil craft currently under development for naval and commercial roles. These range in size from a torpedo-like single-seat Russian craft (reportedly capable of 37 knots) to the 100-ton, 45-knot, PC(H) now undergoing trials by the U.S. Navy. The U.S. Navy is also constructing a 280-ton hydrofoil craft, the AGE(H), which will be roughly contemporary with the Canadian FHE-400 which is due to be launched in early 1966.

The fastest hydrofoil now operating is the 80-ton "Denison", built for the U.S. Maritime Administration by Grumman. In its initial calm water trials this craft achieved 63 knots and has since operated at speeds up to 55 knots in 4- to 6-foot waves. Commercial craft—mainly the 30- and 60-ton Supramar boats—have been in service on sheltered waters for many years.

Nevertheless, there are many questions remaining to be answered before we shall know whether or not the large hydrofoil ship is capable of sustained open-ocean operation as a naval vehicle, and if so, what degree of military effectiveness it has in those roles which are of particular interest to the RCN.

The Canadian project is designed to obtain, in conjunction with the hydrofoil program of the USN, the answers to those questions and within a very few years now we shall know whether or not the potential naval usefulness indicated by paper studies can be realized in fact.



HOT SUIT TAKES CHILL OFF DIVING

CLEARANCE DIVING in the wintry Atlantic is a chilly pastime, but a West Coast leading seaman has invented a special suit to warm up the job.

Ldg. Sea. W. H. Nehring, now of HMCS *York*, Toronto, found he got the chills even in relatively balmy Pacific waters, so he started to work on the problem. His answer was a vest made of absorbent materials, worn under a regulation wet suit and heated by hot water.

Normally, divers can work for about half an hour with a wet suit in cold water, then they must surface to warm up. Wearing Nehring's vest they can extend their working time tremendously.

The new vest has been christened a "hot suit". It has undergone tests at both Pacific and Atlantic coasts and the results have aroused the enthusiasm of Navy divers. Final evaluation of the hot suit is being conducted at Downsview, Toronto, by the Clearance Diving Trials and Development Facility. These trials will be completed by summer and, if they are satisfactory, RCN divers could have hot suits in time for next winter.



Ldg. Sea. Lloyd (Chuck) Doyle, of HMCS *Granby*, clearance diving depot ship in Halifax, flushes hot water through a new type of diving suit, designed by a West Coast diver, Ldg. Sea. W. H. Nehring, to keep divers warm in chilly winter waters. (HS-74203)

Here's how the suit works: Before entering the water, a diver fills his Nehring vest with hot water from a hose. While he is working underwater the warm fluid inside his vest cools fairly rapidly, depending on how cold the water is. But when the vest fluid loses its heat, a hot water hose can be lowered to the diver and he can flush fresh warmth into his suit without surfacing. The system keeps divers much more comfortable and saves the time formerly wasted by divers in surfacing to warm up.

Ldg. Sea. Nehring's invention came at a most opportune time. Canada, the U.S. and Great Britain together have agreed to investigate various diving fields, and Canada's investigations are to be channelled into the field of cold water diving.

The Nehring vest also scores marks because it can be fitted to a conventional wet suit for only a few dollars.

ASSAULT SHIP LAUNCHED FOR RN

HMS *Fearless*, the first of two new assault ships being built for the Royal Navy, has been launched at the Belfast shipyard of Harland and Wolff Limited.

The second ship of this class, the *Intrepid*, is being constructed on the Clyde by John Brown and Company Limited.

This entirely new class of ship is designed to carry heavy tanks and equipment to support an amphibious assault and will be capable of landing troops of an infantry battalion (900 men) or a Royal Marine commando and vehicles by means of landing craft.

The landing craft will be carried in the ship's dock and launched from a special compartment in the open stern which can be flooded, enabling the craft to be floated out.

Ships of this class will have a displacement of 10,000 tons, a length of 520 feet and a beam of 80 feet. Four Seacat guided weapons systems will be fitted, together with two 40mm Bofor guns. *Jane's Fighting Ships*, 1963-64 estimates speed at approximately 20 knots.

HMS *Fearless* is scheduled to be completed in December 1965, while the *Intrepid* is scheduled for completion in May 1966. The ships will cost between \$21,000,000 and \$24,000,000 each.

OFFICERS AND MEN

Fellowship Goes To Officer Cadet

Officer Cadet Raymond Paul Cej, 21, a naval cadet in fourth year chemical engineering at the Royal Military College of Canada, has been awarded a \$3,675 fellowship from the California Institute of Technology, Pasadena, California.

Officer Cadet Cej is working on a thesis on the efficiency and characteristics of trays in distillation columns. When he reports to Cal Tech in the first week of September he will follow a program of studies which will include heat transfer, fluid dynamics, thermodynamics, nuclear engineering and control systems, towards a master's degree in chemical engineering.

He is the son of Mr. and Mrs. P. Cej of Prince Albert, Sask. He graduated from St. Mary's, Prince Albert, in 1960 and attended *Royal Roads*, where he obtained high second class honours before going to RMC in 1962.

At the college he held the appointment of Cadet Flight Training Officer, "A" Flight, and played on the College hockey, rugby and basketball teams.

New Hydrographer At Headquarters

Lt.-Cdr. Bryan Leslie Judd has been appointed Naval Hydrographer at Naval Headquarters.

Lt.-Cdr. Judd entered the Royal Naval Reserve in 1942 and transferred to the Royal Navy in 1946. In 1948, he joined the Royal Canadian Navy. He has served as commanding officer of the cadet training yacht *Oriole* and, most recently, as a member of the staff of the Director of Naval Operations, Naval Headquarters, Ottawa.

Mural Unveiled In 'Stad' Mess

The Atlantic Room of the chief and petty officers' mess at HMCS *Stadacona* was opened May 1 by Rear-Admiral Hugh F. Pullen, RCN (Ret).

In opening the Atlantic Room, Admiral Pullen unveiled a 20 by 5-foot mural depicting a Second World War battle as painted by Lunenburg, N.S., artist Joseph Purcell.

In his remarks, Admiral Pullen described chief and petty officers as the



Rear-Admiral H. F. Pullen, RCN (Ret), unveiled a mural on May 1 to mark the opening of the Atlantic Room in the *Stadacona* Chief and Petty Officers' Mess. The mural, created by Joseph Purcell, Lunenburg, internationally-known Nova Scotia artist, is based on the Battle of Atlantic. Above, left to right, are Mr. Purcell, Joseph Zatzman, Mayor of Dartmouth, Rear-Admiral Pullen and CPO Charles Smylie, mess president. (HS-74891)

"backbone of the Navy", and reviewed the role of the Navy during the Second World War.

Also attending the official opening was Captain D. G. Padmore, commanding officer of *Stadacona*; Mayors Charles A. Vaughan, Halifax; and Mayor Joseph Zatzman of Dartmouth.

Mess President CPO Charles Smylie expressed his pleasure with the new Atlantic Room and said the Battle of the Atlantic mural and motif was to impress upon younger men the importance of the role played by the Navy during the war.

NOAC Convenes In Ottawa

The 41 delegates to the 19th annual convention of the Naval Officers' Associations of Canada, meeting in Ottawa on June 11 and 12, re-affirmed the role of the organization as Canada's "maritime watchdog".

National President Liston B. McIlhagga, of Winnipeg, urged member as-

sociations to keep a vigilant eye on current developments to assure that the Navy should continue as an effective part of the country's armed services.

At the opening session, Rear-Admiral K. L. Dyer, Vice-Chief of the Naval Staff, outlined the implications of integration of the services and the Navy's role in implementing the new defence policy. He presented a broad picture of the naval program for the next few years, this being supplemented with technical details from other members of the Naval Board.

Delegates were assured that, while difficulties would undoubtedly have to be overcome in implementing the new policies, the effectiveness of the Navy in the defence of Canada would not be reduced.

The association unanimously re-elected Rear-Admiral Walter Hose, RCN (Ret), of Windsor, Ont., who is in his 89th year, as honorary president. Admiral Hose, first officer of the RCN to be designated Chief of the Naval

Staff and who is known as the "father" of the naval reserve, spoke briefly to the convention. He received a standing ovation.

Honorary vice-presidents are Vice-Admiral H. G. DeWolf, RCN (Ret), and Cdr. F. C. Aggett, RCNR (Ret). Honorary counsel is C. H. Wills. Honorary chaplains elected by the directors are Very Rev. N. R. Burke, Chaplain (P), RCNR (Ret), and Rev. Fr. M. J. MacIsaac, former Chaplain of the Fleet (RC), who retired in 1957.

Vice-presidents of the NOAC are: H. R. McDonald, Maritimes; A. B. Mundy, Quebec; R. G. Bundy, Ontario; H. B. Vannan, Prairies; R. Rich, West Coast, and Captain J. M. Robertson, RCNR, of HMCS *Carleton*, Ottawa, representing the Naval Reserve.

Continuing in office as secretary and treasurer respectively until a permanent secretary-treasurer is appointed are Harry McClymont and E. W. Burns. The association expressed its profound regret at losing the loyal and highly professional service given by Lt.-Cdr. McClymont in his many years as secretary.

The annual dinner of the NOAC was held in the RCAF Officers' Mess, Gloucester Street, Ottawa, on June 12. Directors and their wives were received at Government House at 1100 on June 13.

Two Captains Appointed

Captain Reginald J. Pickford, of Montreal and Halifax, has been appointed Commander of the Royal Canadian Navy's Second Escort Squadron, based at Esquimalt. He succeeds Captain Godfrey H. Hayes, who has been appointed Canadian Naval Member to the Military Agency for Standardization and executive officer of HMCS *Niobe*, London, England.

Shot in the Dark

The following paragraphs on work-ups appeared in the Report of Proceedings of the captain of a West Coast destroyer escort—not the *Mackenzie*:

"Three light-line transfers and approaches were made by the *Mackenzie's* officers-of-the-watch during each of the night watches, with both ships darkened. These evolutions went off remarkably well.

"During one pitch-black approach, difficulty was experienced in locating the *Mackenzie's* bolo line. After much shouting by me, to my chagrin, it was located tangled in my binoculars. A good shot!"

Captain Pickford was born at Outremont, Que., and entered the war-time RCNVR in 1940. He was mentioned in despatches "for preventing war materials from falling into enemy hands" while engaged in demolition work at Brest, during the evacuation of France. Later, he survived the sinking of HMS *Listrac*, in action with enemy destroyers in the English Channel.

Captain Pickford took command of HMCS *Kootenay* when the destroyer escort commissioned at Vancouver in 1959. Before his new appointment Captain Pickford was Director of Naval Plans at Naval Headquarters.

Captain Hayes entered the RCNR in 1941 after training in HMS *Conway* and service in the Royal Navy. He was awarded the Distinguished Service Cross during the Second World War for "gallantry and devotion to duty" while serving in HMS *Gatimais* on convoy escort duty in the English Channel.

Captain Hayes had been Commander of the Second Canadian Escort Squadron since September 1962.

Officers' Wives Help Hospital

The naval officers' wives of the Atlantic Command held a gigantic pantry sale at the annual Kermesse in Halifax. The Kermesse (village fair) is a large bazaar held every year to raise money for the Halifax Children's Hospital.

In previous years the naval officers' wives have held teas and parties, as well

as having a bake table at the Kermesse. This year they decided to put all their efforts into the bake table. Each naval officers' wife was asked to contribute two homemade items from her pantry.

The response was enormous. There were homemade breads and rolls, pies, fancy breads, cookies, squares, jams, jellies, pickles, mayonnaise and many, many more delicious things. There was even an enormous cake shaped and decorated to look like the destroyer escort *Assiniboine*.

The Kermesse was held on June 12 on the parade grounds of the Canadian Army's Windsor Park. It was a rather blustery day and the Army provided tents for each group to display its wares and protect everyone from the inevitable rain.

The tables were piled high in the Navy pantry tent. Despite the weather the crowds came. By the end of the afternoon about 80 per cent of everything had been sold. However, because of the weather and the abundance of stocks held by all the groups in their various tents, the convener of the Kermesse decided to hold a continuation of it the following day. The naval officers' wives, convened by Mrs. Robert Timbrell and co-convened by Mrs. Kenneth Vause, packed up what was left and the following morning sold all of it.

The profit from the pantry table was \$615, which was turned over to the Children's Hospital shortly thereafter. It was a wonderful response for a worthwhile cause.—J.G.



"Tall in the saddle" is a phrase often used of Texans, only in this case it's the captain's chair on board the *Crescent*. When the destroyer escort visited Washington, D.C., in April Congressman Graham Purcell, of Texas, boarded the ship at Quantico, along with press, television and radio representatives, to journey up the Potomac to the *Crescent's* destination. The congressman is shown with Cdr. V. J. Murphy, the *Crescent's* captain. (Official USN Photo)

Q-SHIP CAPTAIN

The first part of this account of the career of Cdr. Archibald Heurtley (Cappy) Reed, retired from the merchant service, the RNR and RCNR and now living in Vancouver, told of some of his adventures in the days of sail. The following part finds him near the end of his sailing career and about to begin a new one in steam. A few brief years after that (in terms of the 91 years he has spent on earth) he became interested in naval matters and joined the RCNR. His story, as related to Captain William A. Herbert, of HMCS Discovery, continues:

Part Two

AFTER SIX YEARS with Shaw, Savill and Albion Company, "Cappy" Reed had risen to third mate. At this point in his career, he had a terrific row with the second mate and left. "I nearly starved".

Eventually he signed on with the Falkland Island Company as second mate and, on board the *Thetis*, worked the wool trade from the Falklands to London.

After passing his first mate's examination, he decided he would forego the sailing ships for the steamers and joined his old company in the 6,000-ton *Maori*. In 1896 he transferred to the Canadian Australasian Line *War-emo* and in that year made his first trip to Vancouver. He remained on the Sydney-Vancouver run for nearly four years and then, having obtained his extra master's ticket, applied for and obtained his RNR commission as a lieutenant.

"Cappy" Reed realized he had to qualify and so, from 1899 to 1901, he galloped through his gunnery and torpedo courses, ending with a first class reserve in gunnery. In 1901, he was appointed—still a reservist—to HMS *Terrible* under Sir Percy Scott, in China during the Boxer Rebellion. Sir Percy at that time was revolutionizing the gunnery of the Royal Navy.

His life in the *Terrible* came to an abrupt halt. The cruiser HMS *Argonaut* was short of officers and within two weeks of joining the *Terrible* he was informed he would have to leave for the *Argonaut*. His farewell party on board was a gay one, as he remembers it.

The CO of the *Argonaut* was Captain George Cherry, described by Cdr. Reed as a "martinet". He said that Cherry was stern and drove both himself and his ship's company unmercifully. Reed reports that he was not cowed by Captain Cherry and maintained his independence, with the result that he stayed aboard for an additional period, winding up with an appointment of 18 months.

EVENTUALLY his reserve time expired and Reed returned to England where he had been promised a job as commanding officer of a patrol boat organized to police the African lakes. But he was required to wait six months. Living high in London, with expensive dinners and theatre nightly to impress his fiancée, Reed suddenly came to the conclusion that he was going broke and would have to get a job. He applied to Canadian Pacific Steamships and was sent to Vancouver to join the *Empress of India* as fourth officer in 1902. He remained on board the White Empresses of the Pacific for seven years and on one occasion, when his captain fell ill, by special permission from Lloyd's took the *Empress of Japan* under command for two trips.

"Cappy" Reed recalls that he underwent the usual typhoons and gales and the social whirl of passenger liners on



Cdr. Archibald Heurtley Reed, 91-year-old retired RCNR and RNR officer, inspects one of his prized possessions, an autographed picture of Admiral Lord Jellicoe, whom the oldtime officer considers to have been the greatest naval officer since the days of Nelson. Behind the frame of the autographed portrait is a personal letter from the British admiral to Cdr. Reed which will be passed on to Cdr. Reed's son, Cdr. Bob Reed, who is attached to HMCS Donnacona in Montreal.

his Oriental trips but he always managed to spend time on naval training to maintain his status as an officer in the RNR, taking his training in the RN's reserve centre in Hong Kong. His CPR passenger service took him from Vancouver to Yokohama, Nagasaki, Hong Kong and Woosun, the port of Shanghai.

He was married in 1903, at St. James' Church (High Anglican) in Vancouver, to the girl he had courted while going broke in London and in 1911 decided that he wanted to settle down. So he applied for and was successful in getting the post of Harbour Master and Port Warden in Vancouver. After two years of service, a Board of Harbour Commissioners was formed and "Cappy" ruefully explains that the more lucrative post of warden was taken away from him and given to a "politician". As Harbour Master he ruled the waterfront with an iron hand. He expected his orders to be carried out to the letter and woe betide any company or ship that ignored his commands. He was fearful of no man or company and to this day claims that his career was jeopardized by his forthright attitude towards "those b . . . politicians".

IN LATE JULY 1914, when war seemed certain, Cdr. Reed, RNR (Ret), reported to the Admiralty he was ready to serve. His offer was accepted and he was told to report to London at once. He hastily called his Board of Commissioners, informed them that he was going. In spite of their protests, he was adamant and, receiving their promise that he would be reinstated when the war was over as Harbour Master, took the first train available out of Vancouver. In Montreal, he discovered there were four or five ships waiting but they had been held in port because of a submarine scare. He did learn that one ship was to go. He visited his friends in the CPR and told them that he knew they couldn't tell him which ship was going to make a run for it but they could fill in the name of that ship on his passage ticket. They did and he joined the ship that same night and by early August was at the Admiralty in London reporting for duty.

He was sent to Chatham, spent two days there before being assigned to the survey ship HMS *Hearty*, which was sent at once to the North Sea where he spent six months on the dangerous job of surveying the Belgian coast. He appealed to his captain, Lt.-Cdr. Jack Edgell (now Sir John) for a transfer to a "fighting ship" and was successful in being appointed to HMS *Benbow*, then the pride of the third battle

squadron. He was a watchkeeping officer as a two-and-a-half, with the 10 six-inch guns she carried under his command. He spent only a month in the *Benbow* before being transferred to the battleship HMS *Duncan* for service in the Eastern Mediterranean. It was in the *Duncan* that an anchor wire snapped and he jumped on it to prevent sailors being injured. It wasn't until after the war that his fingers and toes were amputated from the results of the daring deed. "At my expense, too," he sighed.

Lt.-Cdr. Reed was promoted to commander on Sept. 30, 1916.

Does the loss of his fingers bother him? Not a bit. "I can steal just as much as I ever did," he chuckled.

He was transferred back to Chatham after two and a half years in the *Duncan* as assistant gunnery officer.

ONE DAY he was summoned to the C-in-C's office and informed that next morning at 1000 he was required at the Admiralty to see the Second Sea Lord.

"I immediately wondered whom I had offended or what I had stolen," Cdr. Reed laughingly remembered, "but, next morning, booted and spurred, there I was in London. Imagine my surprise when I was informed that a couple of admirals had recommended me for special duty.

"At the Admiralty, they asked me if I had ever heard of 'Q' Boats and, of course, I replied that I had heard of them but knew nothing about them. They wondered if I would volunteer to serve in them as a commanding officer and I assured them that I would, knowing absolutely nothing about their work.

"I was accepted, told to return to Chatham and look up a couple of officers and some senior petty officers who had served in them and bone up all I could and I would be advised when to join my ship. My appointment came and I went to Dundee to join a small coastal ship named *Goodwin*, which was being built for the coastal passenger trade. On the outside she had the outline of a merchant ship, but her insides were like that of a small cruiser.

"Of course, the name '*Goodwin*' was not on any list, either Admiralty or Lloyd's, and her sea-going name, HMS *Underwing*, was known only to the Admiralty. Our only identification was a number across the front of the ship, 'PC-49', which I had taken from a song popular at that time."

Cdr. Reed was reluctant to discuss his career in Q-ships since his role, according to him, was just routine, not the "guts and glory" events that happened to some of his compatriots. However, to

the accompaniment of a beating of the arms of his chair, he did recount what he says was his most interesting action which secured for another Q-boat commander a DSO and almost a court-martial for Reed.

His "chummy" ship was the *Rule*, commanded by Cdr. Ronald Langton-Jones, and frequently, while in harbour, the two used to work out plans to kill a submarine under certain sets of circumstances. Cdr. Reed said they had worked out about 50 of these attack schemes. One of them was quite simple. When a ship in convoy was torpedoed, he would manoeuvre his *Underwing* alongside and offer himself as "live bait" to the lurking U-boat.

ONE DAY, steaming with a convoy about 200 miles south of Cape St. Vincent, Gibraltar-bound, a large merchant ship was "fished". According to his pre-arranged plan, Reed steamed the *Underwing* alongside, launched boats to pick up survivors and generally made himself useful around the unfortunate steamer. At this point, Reed interjected an explanatory note. On assuming command of his Q-boat, Admiralty had instructed him to "Do anything you want. We'll back you up. Don't be afraid to lose your ship, because if you get one submarine you've proved your value." But there was a standing Admiralty order from the early days of the First World War stemming from three warships having been destroyed by a single, submarine, one after the other, because they had stopped to pick up survivors. The order stated that on no account was one of HM Ships to stop and assist a stricken ship in the presence of the enemy.

The ruse near Cape St. Vincent worked completely. While Reed went about rescuing people, the *Rule*, under Langton-Jones, kept a sharp lookout and sighted the U-boat's periscope slicing through the water, bent on shooting up Reed's ship.

"I heard some dull explosions", Cdr. Reed recalls, "and though one of my men on the bridge thought it was our boilers, I knew it was something else. Then, White Ensign unfurled, the *Rule* swept by me at full speed, messaging: 'Submit have confirmed kill.'"

"What had happened was this: Langton-Jones had kept behind the submarine and, as soon as he saw the periscope, he knew the German was lining up ready to blow me to Kingdom Come. He ran over the U-boat, dropped four depth charges on him, which blew him to atoms. Our plan had worked perfectly.

"There was great excitement at Gib. Langton-Jones was given a hero's wel-

come, and they added a bar to his DSO. As for me, I was sent for by the Chief of Staff who wanted me to submit my reasons in writing for having stopped my ship in the presence of the enemy contrary to standing Admiralty orders. I could be court-martialed, I was told.

"Well, I called him a fool and told him that if I did set down my reasons in writing, he'd look like an ass and I had no intention of writing anything. Later that day, I met Captain Evans, of the *Broke*, who complimented me on my ruse and I told him that COS was after my scalp. He told me not to worry. I didn't and I heard nothing more about it. But there was the *Rule* getting all the glory and I was getting a rocket. But we did kill that submarine."

WHEN HE RETIRED, "Cappy" Reed moved to Bowen Island, just outside the Port of Vancouver, where by hand he cleared seven acres of timber land and built a house. Shortly after his retirement, he received a top secret letter from the RCN, through Intelligence, wondering if he would consider "an assignment that was almost 99 per cent certain fatality". Because of his experience as a hydrographer, Reed was needed if he would agree to make surveys of the Burma beaches, preparatory to an invasion under Lord Louis Mountbatten, then Supreme Commander, Southeast Asia. Reed immediately volunteered, but the plan was cancelled.

"I told them I was as fit as a man of 25 and would be willing to go anywhere. I told them, too, that even though I had one kidney removed after a steeplechase horse had fallen on me, the doctors told me that with a lot of care, I might possibly live for another 20 years—maybe! They apparently couldn't get a force mounted for the Burma show, because I didn't hear any more about it," reflected the retired officer.

Cdr. Reed is proud of his two sons. Robert, who holds a commission as a commander (E) in the RCNR, is an executive with Canada Steamship Lines in Toronto and served throughout the war with the Royal Navy. The junior Cdr. Reed won the DSC and was mentioned in despatches four times. Dick, who worked with an aircraft factory during the Second World War is with a large engineering firm in Montreal. Mrs. Reed died in 1949.

For all his pepperpot speech, "Cappy" Reed is a deeply religious man. He attends St. James Church regularly, walking the two and a half miles into Vancouver's East End and back every Sunday.

He abhors television, except for the rebroadcast of the Grand National Steeplechase, keeps apace of the news through newspapers (he still subscribes to the *Sunday Times*) and his small radio, paints ships under full canvas in water colours and has an entire wall filled with military history, with the emphasis upon Sir Winston Churchill's works and accounts of naval actions in both world wars.

"Cappy" Reed still drinks a tot or two of lime juice instead of eating vegetables, sometimes spicing the drink of his apprentice days with a liberal two-ounce splash of something stronger. His most prized possession is an autographed picture and personal letter from Admiral Lord Jellicoe, whom "Cappy" considers to be the greatest sailor in the world.

He feels that if Canada is to keep up with the times she should have nuclear submarines today but he hastens to add "anyone who spouts off about today's Navy is liable to make a plain ass of himself. We should keep abreast of the times, though, keep in the running."

Cdr. Reed admires the young sailors of today, not as seamen, but because of their scientific knowledge.

What is his recipe for a long and happy and healthy life?

"No recipe at all. Keep out self entirely. Try to help someone else, even if it is an old tramp down the street. Be natural, devote yourself to some service," he thundered, as he took another pull at his drink and banged on the arm of his chair.

The End

RN'S FLAG 100 YEARS

MOST PEOPLE appear to think that the White Ensign has been the flag of the Royal Navy from time immemorial, but it was not until July 1864 that the White Ensign really became the flag of the RN.

For over 200 years previous to this date, the Royal Navy was divided into three squadrons, which were designated by their respective squadrons, red, white and blue. The red squadron ranked first, the white came next.

Ships sometimes moved from one squadron to another and it was necessary, therefore, that they should carry three suits of colours to be able to hoist the correct ensign.

The red and blue ensigns were not easily recognizable in the smoke caused by battles and could be mistaken, at times, for the flags of foreign ships. For this reason, Nelson, Vice-Admiral of the White, at Trafalgar, ordered the British Fleet to hoist the White Ensign, this being more easily distinguishable from the French flag. Collingwood's squadron would normally have worn the Red Ensign.

Seniority difficulties regarding the admirals on the red, white and blue lists caused difficulties, but an Order in Council on July 9, 1864, put an end to the three-flag system.

The same Order in Council directed that the White Ensign was to be hoisted at 8 o'clock from March 24 to September 20, and at 9 o'clock from September 21 to March 24 at home and 8 o'clock or 9 o'clock, as the commander-in-chief directed, when abroad. Flags should fly until sunset, when they were to be hauled down.

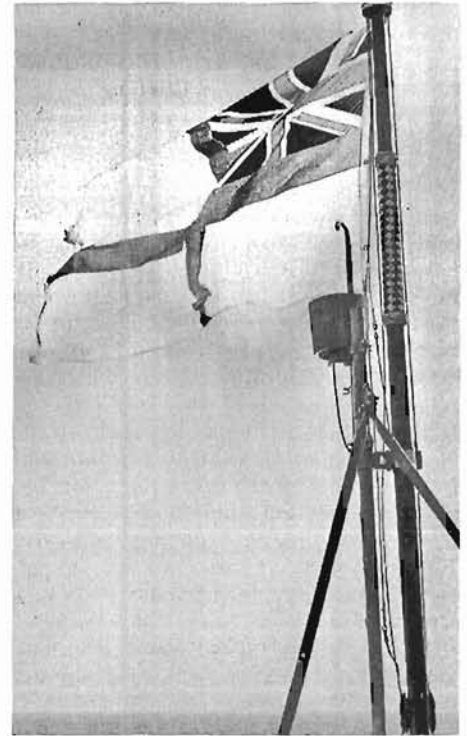

The ceremonial hoisting of the ensign has over the years altered a little. Old-timers will recall how in barracks a guard and band were always paraded for "Colours" but, now that bands are few and far between, this ceremony is going by the board to a great extent, although, of course, hoisting is always carried out with considerable respect. In Portsmouth Barracks, the ensign is hoisted at 8.30 every morning of the year.—*Navy News*, newspaper of the Royal Navy and the Royal Naval Association.

AFLOAT AND ASHORE

ATLANTIC COMMAND

HMCS *Restigouche*

June 9 again brought annual inspection for HMCS *Restigouche*. Officiating was the Commander of the Fifth Canadian Escort Squadron, Captain D. L. Macknight.

Captain Macknight spoke to the ship's company and recalled the part played by the *Restigouche* in escorting HMCS *Bonaventure* to Cyprus and return. He also spoke of future commitments of the ship and encouraged the ship's company to keep up its high standard of efficiency.

The following day, in company with HMCS *Terra Nova*, the *Restigouche* proceeded to local areas to demonstrate her proficiency at anti-aircraft and surface shoots. At the end of a busy day, the ships anchored in St. Margaret's Bay and proceeded to carry out competitive drills at anchor under the direction of the inspecting staff. The inspection ended with a mock attack by divers from HMCS *Granby* in the early hours of the next morning.

Shining Target Attracts Shark

From all accounts, there are supposed to be literally millions of sharks in the Indian Ocean, where three Pacific Command destroyer escorts took part earlier this year in the big Commonwealth training exercise "JET '64".

But in weeks of steaming few of the sharp-toothed denizens of the deep were seen by members of the ships' companies.

Squadron dental officer Major David Carmichael wondered about the presence of sharks on one occasion when the *Fraser* was at a stand-still during an exercise. He didn't have to wonder very long.

He tossed overboard the bright lid of a large, empty paint can. The shiny disc zig-zagged its way into the clear blue water, and within seconds a six-foot shark was in the immediate vicinity. Its blue-grey body bore down on the paint can top and, all of a sudden, the lid's flashing descent was stopped. But only for several seconds—enough for the shark to realize that paint can lids are tough and not tasty.

The lid continued its descent. The shark vanished, too, probably needing services of the dental officer.



PO Joseph H. Peters returned to Charlottetown in June with his ship HMCS *Fort Erie* and met his former cub pack, the First Charlottetown "A" Pack. PO Peters was leader of the pack while stationed in Charlottetown a year ago. (HS-75252)

Again at sea, the *Restigouche* and *Terra Nova* met the *Kootenay* and *Columbia*. There followed two days of anti-submarine exercises with HMS *Alcide*, Royal Navy submarine based at Halifax.

Each of the destroyers had seven cadet midshipmen undergoing 3rd phase ROTP summer training and during each day special demonstrations and exercises were held for the benefit of the cadets.

At noon on June 14 the four ships steamed into Boston to begin a four-day visit. Most of the ship's companies attended a baseball game between the Boston Red Sox and the Baltimore Orioles on the afternoon of their arrival and then went on to tour Boston.

Boston provides glimpses of history at every turn for personnel ashore. The sites of the Boston Tea Party and the Boston Massacre were among those visited by RCN sailors walking round the city.—J.K.S.

HMCS *Kootenay*

Looks of apprehension soon gave way to smiles and excited chatter as vari-

ous groups of children were guests of the men of HMCS *Kootenay*. During the Fifth Escort Squadron's visit to the Mediterranean last winter, time was taken to entertain 105 orphans from the Children's House, Leghorn, Italy and 43 children from St. Israil's School for Orphans in Lisbon, Portugal.

Men from all departments in the ship acted as guides, explaining as best they could in "sailorese" the facts of life at sea. After a tour of the ship, cookies, cake and candy were served in the main cafeteria followed by cartoon movies. Here there was no language problem!

In appreciation the children sang songs in their own tongue.

In Halifax, the *Kootenay* has been host to a group of students from Hartford, Connecticut, two high school classes from King's County, Nova Scotia, and a Cub pack from Dartmouth, N.S.

VS 880

CBC Mobile Productions were looking for a new and different location for staging "Don Messer's Jubilee".

They found it.

On May 14, mobile TV equipment, ranging from cameras to huge trucks crammed with electronic gear, was installed in the vast hangar of Anti-Submarine Squadron 880. Don Messer was putting on his best show of the season in one of the biggest barns he could find.

A wooden platform, surrounded by the Squadron's gleaming CS2F Trackers, provided the stage for Don Messer and his Islanders, Don Tremaine, who MC'd the show, Marg Osborne and Charlie Chamberlain. The Buchta dancers skipped their way through a number of dances on the stage, which was emblazoned with a huge VS-880 badge.

Spectators were in abundance, giving forth with loud yahoos and other appropriate applause. Some 800 service personnel and their families saw the live production of the CBC show, which was presented over the network on June 8 by videotape.

NAVAL DIVISIONS

HMCS *Star*

Hamilton's naval division, *Star*, has a new commanding officer.

Cdr. H. C. Tilbury relieved Cdr. R. G. Wilson, who headed the division for the previous year and a half.

The change-of-command ceremony took place during *Star's* annual inspection in May by Commodore P. D. Taylor, Commanding Officer, Naval Divisions.

The new commanding officer, Cdr. Tilbury, had been executive officer of the divisions since October 1962. He joined the Royal Canadian Naval Volunteer Reserve at Hamilton in 1940 as an electrician and served throughout the Second World War as an instructor in Halifax and at sea.

Demobilized in 1945 as an acting sub-lieutenant, he rejoined the naval service at *Star* in 1949 and has served continuously with the division since.

Cdr. Wilson joined the RCNVR at Hamilton in 1942 as an electrical artificer. He was demobilized in 1945 and returned to *Star* in 1948, serving until 1960. In January 1963, he was recalled to the active naval reserve to take command of the division.

HMCS *Hunter*

There may have been a hint of the shape of things to come during the annual Royal Canadian Sea Cadet inspection at HMCS *Hunter*, the Windsor naval division, in mid-May.

The Cadet of the Year award was presented to Sea Cadet CPO Larry Peddie, of Sandwich West Township,

by Keri Lewis, of the Windsor Naval Officers' Association, representing the Navy League of Canada. The inspecting officer was Lt. V. S. Curry, Assistant Area Officer, Sea Cadets, from Toronto.

What distinguished the occasion from others of its kind was that earlier in the day Cadet Peddie had appeared in the uniform of the Essex and Kent Scottish as a member of the Army Cadet precision team of Massey high school at the school's annual cadet inspection. For appearing with the precision team, he was presented with a badge by R. B. Whetstone, principal.

SEA CADETS

RCSCC *Falkland*

The annual inspection of Royal Canadian Sea Cadet Corps *Falkland*, under the command of Lt.-Cdr. W. J. Eastwood, RCSC, took place on May 6 in the drill hall of HMCS *Carleton*, the Ottawa naval division, with a large number of relatives and friends in attendance.

The inspection was by Rear-Admiral C. J. Dillon, Naval Comptroller, who first inspected the cadets drawn up in divisional order, then took the salute as the cadets marched past.

Annual awards were presented to the cadets, after which Admiral Dillon spoke to the cadets and their friends. He thanked the Corps for the opportu-

tunity of seeing at first hand the work being done on behalf of youth training. He stressed the vital need for the cadets to continue their education, pointing out that the world of today was a specialized one in which a good education was of extreme importance.

He hoped that out of this form of cadet training, the defence forces of Canada would always have a reserve of well-educated, dedicated young men to whom they could turn for leadership when the occasion arose.

One notable feature of the inspection was that the entire proceedings were under the command of senior cadets, with the officers standing, as it were, on the side-lines. This idea was introduced by the commanding officer, Lt.-Cdr. Eastwood.

A presentation by two of the cadets on behalf of the Corps was made to Lt. Bruce Mundy and Mrs. Mundy in recognition of eight years devoted service by Lt. Mundy to the corps as executive officer. Lt. Mundy was forced to resign from active duty because of the pressure of other duties but will continue his association with the Corps through membership in the Ottawa branch of the Navy League of Canada.

Representatives of the Navy League of Canada, the Naval Officers' Association and the Falkland Chapter, IODE, attended the inspection.



Cyril Robinson, staff writer of *Weekend Magazine*, presents a \$100 cheque to the ship's fund of HMCS *Athabaskan* in appreciation of the ship's making available to the magazine photographs depicting the *Athabaskan's* rescue of 34 seamen from the tanker *Amphialos March 1*. Shown, from left, are Lt.-Cdr. Stan Dee, executive officer; Mr. Robinson; Cdr. P. R. Hinton, captain of the *Athabaskan*; CPO B. C. Stevens; PO A. J. Tremblay, and Captain J. P. T. Dawson, Commander, First Canadian Escort Squadron. (HS-7462)

LONG WAY ROUND

Part Three

AFTER A RESTFUL four-day passage across the Bay of Bengal, HMCS *St. Laurent* entered the crowded harbour of Colombo, Ceylon, on the morning of March 21. The ships secured at Queen Elizabeth Quay in downtown Colombo and the ship's company was not long in venturing to see the sights.

A pear-shaped island, 270 miles long by 140 miles wide, Ceylon offered a multitude of attractions. For the sight-seer, many tours were organized around Colombo and into the interior of the island. For the bargain hunter downtown Colombo abounded in shops and stalls of all descriptions selling everything from carved ebony elephants to famous Ceylonese tea.

Probably the most intriguing aspect of our visit to Ceylon was the presence of great gem markets in Colombo. Ceylon has been famous for her gems and semi-precious stones since early historic times. Sapphires, rubies, opal, aquamarine, garnet, topaz and moonstones all abound and, indeed, caught the eye of all.

To those who had the opportunity to tour the interior of the island, Kandy, 72 miles from Colombo, seemed to be the favourite. On the way up to this ancient hill capital you pass through the coconut palm groves which grow profusely along the coast and in the low lying lands, then through the rubber district which stretches from the foothills to the low mountain sides and, finally, as you continue to climb up the interior mountains, you enter the tea district. Here, nestled in a beautiful valley is Kandy. Famous for its restful atmosphere, the Dalada Malegawa, or temple of the Sacred Tooth of Buddha and the beautiful Botanical Gardens of Peradeniya, Kandy provided at least one pleasant afternoon for many members of the ship's company.

On March 26 our brief visit to Ceylon came to a close and we manoeuvred once again through Colombo's busy harbour, north-northwest through the Lacadive Islands to Karachi, Pakistan.

Unlike our arrival in any other harbour we had yet visited, our greeting in Karachi was slightly obscured to say the least. On the morning of March 30, we arrived off Karachi to find a rather



A snake charmer entertained men of the *St. Laurent* when the ship paid a visit to Colombo, Ceylon. Learning about the reptiles, and how they are trained, are Ord. Sea. Donald K. Spales, Ldg. Sec. Clifford Watt, and Ldg. Sec. Robert B. Orr. (E-74896-186)

short-lived dust and sand storm in progress. With the visibility reduced to just a few hundred yards, we remained outside the entrance until the storm subsided and then, with rapidly improving visibility, we entered Karachi for a five-day visit.

Sitting oasis-like on the edge of a desert, Karachi is the largest, youngest and most modern of all cities in Pakistan. It, like many cities we had previously visited, has two faces. While the city may be known for its ultra-modern buildings, fashionable housing societies, wide avenues, parks and garden, on the other hand, its fleet of donkey and camel carts, crowded bazaars, pavement quacks and palmists, snake charmers and faith healers depict a picture torn from medieval history. This contrast made our visit to Karachi most fascinating.

Although there was little in the way of sightseeing in the desert area surrounding Karachi, the city itself and the nearby beaches provided ample entertainment. Shopping again was a highlight and if one was not shopping for a camel saddle or a piece of local silk, he was shopping for some finely tooled brassware or Pakistani leather goods.

In retrospect our brief stay in Pakistan held a fascination all its own. The beautiful warm days and cool evenings, the hustle and bustle of the city streets, the friendliness of the people and the mixture of the old world and the modern made our visit memorable.

On the morning of April 4 we left Karachi behind as we set heading across the Arabian Sea to Aden. Our passage took five days and after our busy itinerary these were a welcome

relief. On the morning of April 9 we entered Aden for an overnight refueling stop.

East of the straits that broaden from the Red Sea into the Gulf of Aden lies a shallow peninsula of jagged rock formed by volcanic eruption. Tiny, 78 square miles in area and strategically important, this is the crown colony of Aden. Across the Isthmus of Khormak-sar, which joins Aden to the mainland, is the Aden Protectorate, covering an area of 112,000 square miles bordered on the north by the Yemen and Saudi Arabia, and in the east by Muscat and Oman. Sun-scorched, agriculturally barren and lapped by a sluggish warm sea, Aden is a thriving trading area between East and West. Its magnificent harbour is active and its small, crowded shops are prosperous and a delight to shoppers who are prepared to drive a hard bargain and waive any suggestion of quarter.

Although our visit was short, everyone had at least a brief opportunity to proceed ashore.

Midnight on the evening of March 10 found the *St. Laurent* through Hell's Gate—the narrow entrance to the Red Sea and for the next four days we steamed northward, arriving at Suez early on the morning of April 4. Here we waited for the second largest convoy in the history of the canal to form up before proceeding northbound through Suez.

Immediately after arriving at our anchorage off Suez, His Excellency J. Chapdelaine, the Canadian Ambassador to the United Arab Republic, came aboard to accompany us through the canal and on to Alexandria, our next port of call.

The canal is 86 miles long and is divided into two main parts, the southern part from Suez to the Great Bitter Lake to Port Said on the Mediterranean. South and northbound ships are formed into convoys which transit the canal twice daily for northbound ships and once daily for southbound ships.



When the *St. Laurent* paid a visit to Colombo, Ceylon, the Captain of the Royal Ceylon, Commodore R. Kadirgamar, paid an official call on Cdr. D. D. Lee, commander of the *St. Laurent*. (E-74896-199)

We departed Suez late in the morning of April 14 and arrived in the Mediterranean at midnight the same day.

After a leisurely passage westward in the Mediterranean we entered Alexandria on the morning of April 16 for a five-day visit. Almost immediately on arrival, our chaplain, Rev. A. J. Mowatt, made arrangements for a host of tours for the ship's company. Probably the most interesting of all was the visit to Cairo.

Here, about 70 members of the ship's company had an opportunity to spend an entire day and it will truly be one that will be long remembered. The day began at 6 am when the bus left on a 3½-hour trip to Cairo. Upon arrival we toured the old city and visited the famous Cairo Museum. Then we visited

the Citadel and the Mohammed Aly Mosque with its magnificent view overlooking Cairo, the Nile and the pyramids of Giza far in the distance.

After lunch we travelled the 15 miles out of the city to Giza, to view the Sphinx and the famous pyramids, tombs of the Royal Pharaohs of the Third and Fourth Dynasties, dating from 2780 BC. All astride camels, with cameras draped over our shoulders, we set off to have a closer look at the pyramids and Sphinx. The largest of man-made mountains is the Great Pyramid of Cheops. So exactly hewn were its 3,000,000 blocks of granite that no mortar was needed to bond them. It stands 441 feet high, and took approximately 40 years to construct. A few of the more daring ventured to the top of Cheops to view the countryside but most were content to take dozens of pictures and concentrate on controlling their loose-jointed, rather independent, ships of the desert.

Returning to Cairo we had an opportunity to walk through the Khanal-Khalili bazaar and then, just at sunset, all went sailing up the Nile. This was a perfect opportunity to rest our aching bodies and view the skyline, the smooth domes and delicate minarets of many beautiful Islamic mosques and the many beautiful modern buildings which adorn the banks of the Nile.

After dinner we set off for a brief glimpse of Cairo by night before setting out on our long trip back to Alexandria.

For those who did not travel to Cairo various tours of Alexandria and the surrounding countryside were organized. By the end of our short visit few, indeed, had not had at least a brief glimpse of Egypt and life in this ancient land.

Our visit to the United Arab Republic came to an end on the morning of April 21 and we sailed from Alexandria's busy harbour bound for our next port of call, Haifa, Israel.

(END OF PART III)



HERE AND THERE IN THE RCN



HMCS Saskatchewan, busy this spring with school relations cruises, had Mayor Peter Maffeo, of Nanaimo, B.C., as a guest during one of the cruises out of the up-Island city. His worship is shown going ashore following the voyage. (E-76220)



The Pacific Command, with enviable records for donations to blood clinics, has been honoured by the Red Cross. Special certificates for total of 90 donations were presented to three donors by C. R. Steen, president of Victoria and area Red Cross. Presentations were made during a recent visit of the mobile blood clinic to Naden. From left: Mr. Steen; PO M. J. Bernier, HMCS Mackenzie, 50 donations; Ray E. Taylor, HMCS Naden fire hall, 20 donations, and Lt. Eric Haywood, Command Photographic Officer, 20 donations. (E-76957)

MACKENZIE



Eleven-year-old Choung Wai was welcomed on board HMCS Mackenzie at Hong Kong. The youngster is the CARE plan foster son of 33 Utility Air Squadron, based at Patricia Bay, B.C. (E-75971)



Yiu Chi Ling, 11, one of nine children of a Hong Kong family, was "adopted" by the ship's company of HMCS Margaree four years ago. The sailors contribute to her welfare monthly through CARE. Little Miss Ling, and her parents, were guests of HMCS Fraser when the ship visited Hong Kong last spring. Shown with her and her new doll are AB Dennis Moore and Ldg. Sea. Ron Duffy. (CCC2-1629)



Stalwart Nipigon sailors, hand-picked for size and bearing, formed the Royal Guard for His Excellency, General the Rt. Hon. Georges P. Vanier, Governor General of Canada, who was guest of honour at the May 30 commissioning of the new destroyer escort in Sorel, Que. (Photo courtesy Marine Industries Limited)



FAMILY PORTRAIT—In the sunshine of Charlottetown, the ship's company of HMCS Fort Erie posed for their portrait. The Fort Erie was in Charlottetown to help with Prince Edward Island's Centennial Celebrations. (HS-75248)

ABOARD THE USS MONITOR

THE ENCYCLOPAEDIA BRITANICA defines a monitor as a "shallow-draft warship, usually with very low freeboard, fitted with heavy guns in one or two turrets and specially designed for coastal bombardment". It mentions that the idea probably originated with Captain Cowper Coles, RN, during the Crimean War in 1855 but that the British had used bomb ketches as early as the 17th century. Steam propulsion was needed to make the monitor practical. It also says: "The history of this type begins with the most famous vessel of the class, the *Monitor*, designed by John Ericsson in 1861".

Ericsson's *Monitor*, building for the North, and the conversion by the South of the frigate *Merrimac* to an ironclad became practically a race. The *Monitor* was no conversion job. She had hardly any freeboard, except at the middle where there was a gun turret nine feet high, housing two 11-inch Dahlgren guns. She drew only 10 feet, six inches, and other dimensions included a length of 172 and beam of 41 feet, six inches. Armour included one inch on the deck, five inches on the sides and eight on the turret. She displaced about 1,200 tons and she had a crew of 58. She came to be called "Yankee cheese-box on a raft", but she was deeply feared.

You don't have to be a Civil War buff, or even a student of naval history to enjoy *Aboard the USS Monitor: 1862*. This is a volume of letters from the acting paymaster of the ship to his wife in Illinois, edited by Prof. Robert W. Daly, U.S. Naval Academy, and

BOOKS for the SAILOR

published by the U.S. Naval Institute. It was issued on March 9, the 102nd anniversary of the battle between the *Monitor* and the *Merrimac*. It introduces the Naval Letters series of the U.S. Naval Institute.

The "paybob" was W. F. Keeler, a merchant turned naval officer. His letters are chatty and detailed. The book's format is a work of art, a delight to read and a joy to behold.

Keeler, anxious to share his life in this renowned new ship, wrote his wife prodigiously. He indicated some of the letters were for her to touch up a bit and circulate. He also wrote the odd piece for northern publications. He served in the ship from her entering the war to her foundering in a storm, and emerged unharmed from that to describe her finish in another letter back home.

The volume is the first in a new Naval Letters Series. If the successors match the first one, nautical libraries will be greatly enriched.—H.C.W.

ABOARD THE USS MONITOR: 1862, by William F. Keeler; published by U.S. Naval Institute, Annapolis, Md.; \$6.50 (3e).

CAT AND MOUSE

JAMES BENSON and C.E.T. Warren, just to reverse the order of their names for a change, have a special talent for telling of underwater exploits. They have a knack of explaining complicated environments and moods in simple understandable terms and catching the elations and depressions, beliefs and superstitions, and periods of intense activity and lethargy common to persons who conduct much of their business under water.

Their current book is *Will Not We Fear—The Story of His Majesty's Submarine Seal and of Lieutenant-Commander Rupert Lonsdale*.

The *Seal* was a large minelaying submarine commissioned in February 1939. On August 4, she sailed for the Far East. When war was declared on September 3, 1939, the *Seal* was at Aden and was assigned to local patrol. Subsequently she served in the Mediterranean and participated in convoys to and from Halifax.

Then came the fateful patrol—a minelaying mission through the Skagerrak into the Kattegat. Early on the morning of May 4, 1940, as she was nearing the area where the mines were to be laid, the *Seal* was forced to dive by an aircraft which near-missed her

SCHOOLROOM RUN LIKE SHIP

The following story appeared in the Hamilton Spectator on May 29 under the heading Dundas Class goes Navy:

ALL IS SHIP-SHAPE with the crew "aboard" HMCS *Terra Nova* these days.

Terra Nova is a classroom in Greenacres Public School, Dundas.

The crew is composed of grade six students.

Unofficial "Admiral of the Fleet" is Miss E. Duvin, a pert teacher in her first year.

"The Captain" is a student and all ship's officers got their jobs on a points-merit system based on good behaviour.

The ship-in-a-classroom is Miss Duvin's method of holding discipline among students and it has worked—there is not a mutinous spark in sight, she claims.

It started when Miss Duvin realized on her first day that it wasn't all apples for teacher. She looked for a discipline aid, then hit on the navy theme.

She wrote to two retired admirals for help and they suggested the class adopt an RCN ship.

Students wrote off to captains of four destroyers based at Halifax. Back came the replies. The crews were delighted.

So the Grade six class at Greenacres

has now 36 matelots, not students; it has four ships' crews, not sections; "prefect" is a captain and there's a first lieutenant and four petty officers to crack down on mutineers.

And you never saw a more cheerful Admiral of the Fleet.

"Many of the students are writing to the sailors and they seem to love it," she said yesterday.

"I have found a wonderful way to keep discipline and I think the idea might spread".

Ships concerned in the adoption scheme are the *Assiniboine*, *Terra Nova*, *Skeena*, and *St. Laurent*.

with a bomb that caused slight damage. From this moment the hunt was on but, despite heavy anti-submarine trawler patrols, the *Seal* managed to lay the mines in an area designated as an alternative target.

Then a game of cat and mouse developed as the *Seal* twisted and turned to evade detection by the trawlers and a second group of trawlers which appeared in the early afternoon. By 1830 the *Seal* appeared to be clear of all trawlers and caught a stop trim on a layer at about 90 feet down. As the crew relaxed and began to eat their evening meal an explosion holed the submarine aft. Only immediate shutting of watertight doors kept the submarine from flooding throughout. Heavy and out of control, the *Seal* settled to the bottom.

The tense description of the struggle to survive forms the heart of the book. Survive they did, and at 0110 on May 5, they lurched to the surface. The *Seal* was terribly wounded but there were no German units in sight. The explosion which caused their trouble appears to have been a German mine.

The Germans did not give up the chase and, before daylight, aircraft commenced a sweep of the area. Out of control and barely able to keep afloat the *Seal* fell victim to three German aircraft. The seaplanes carried off the commanding officer and second coxswain as proof of their victory. The capture of the crew by a German trawler makes intriguing reading. The *Seal* was towed to Frederikshavn and, after rapid repairs to make her seaworthy, towed on to Kiel.

Except for one man who had disappeared over the side in the Kattegat, the entire crew became prisoners of war. Two men escaped. PO Barnes got to the Russian lines but appears to have been killed. ERA Lister, who qualified for the infamous Colditz prison camp as a hardened escaper, quickly arranged to be "unqualified", because he wasn't an officer. From a prison camp at Breslau he made good an escape to England via Switzerland.

With the end of the war and the return of the *Seal's* old crew came the inevitable courts-martial to tidy up the loose ends.

Exciting the book is but it would be interesting to read the story of the *Seal* in German hands. There should be more detail of the escape and disappearance of PO Barnes and survival of his companion in the escape; more about the escapades of the apparently irrepressible ERA Lister and more of the prosecution and defence arguments at the courts-martial.

Through the book, the reader becomes aware of the close association of the *Seal* personnel and the people of Seal, a small Kentish village. The Kentish villagers, ably led by the tireless Miss Coleman, were overflowing sources of the hope and strength that can be given to prisoners of war and the families of prisoners of war by both tangible and intangible attentions—E.G.G.

WILL NOT WE FEAR, by C. E. T. Warren and James Benson; published by George G. Harrap and Co., Ltd., London; published in Canada by Clarke, Irwin and Co., Ltd., 791 St. Clair Ave., W., Toronto.

LETTERS TO THE EDITOR

Dear Sir:

After reading the announcement about the new shiplovers' organization in the February 1964 issue of *The Crow'snest*, I believe that readers would welcome information about an organization which is now well established after almost 14 years' operation, and whose 98th bulletin (running to almost 100 pages) is now in preparation.

This organization, the Belgian Nautical Research Organization, is truly international, having over 500 members throughout most countries, but whose bulletin, *The Belgian Shiplover*, is in English as the most universal naval language.

The BNRO offers eight services at present:

- The bulletin, six times a year with a total of over 500 pages annually, contains ship lists (both mercantile and naval), articles (by such outstanding members as Henri Le Masson, William H. Davis and Dr. E. Lacroix), bibliographies of books on sale around the world, current nautical information, contact with shiplovers around the world.
- Exchange and identification service for merchant ship photographs.
- Exchange and identification service for naval vessel photographs.
- 28 Periodicals (the leading ones in

the world) are circulated to those wishing them.

- Search and exchange book service, of secondhand books.
- Search and Exchange Register (*Jane's*, *Weyers*, *Les Flottes de Combat*, *Brassey*, etc.) Service.
- Basic data information service—a list of the principal sources of information held by the members, offered as an aid to other members. Model service, offering, besides the articles in the TBS, advice and information to interested members.

The BNRA has as president the internationally known Paul E. R. Scarceriaux, member of the l'Académie de Marine de Belgique, and the patron is Marcel Malderez, secretary-general of Ministère des Communications. For information, members should write to:

M. Paul E. R. Scarceriaux,
16 Avenue J. Stobbaerts,
Brussels 3, Belgium

An interesting point arises in the Naval Lore Corner #125, in the March/April 1964, issue of *The Crow'snest* about the nomenclature of naval vessels. The ship identified as the U.S.S.R. minelayer/training ship *Marti/Elizabetha* was originally the Russian Royal Yacht *Shtandart*; but, more important, although *Jane's Fighting Ships* identifies her now as *Elizabetha*, *Weyers Flotten-*

taschenbuch gives her name as *Oka*. The problem has been solved, in this case only, by the fact that this ship has been removed from the Soviet Fleet List, as reported in *Jane's* for 1963/1964.

Yours sincerely,
GERALD A. GILL

3563 Highway Drive,
Trail, B.C.

Dear Sir:

It has come to our notice that not too long ago a group of Navy boys donated the sum of \$200 to the Vincentian Home on Brunswick Street. This is a home, staffed by the Sisters of Charity, which cares for elderly Catholic gentlemen.

This donation enabled the Sisters to procure a large electric toaster which will make 150 slices of toast in 30 minutes.

May I on behalf of our members express through your columns the deep appreciation of the kindness and good will expressed by these Navy boys in their unselfish assistance to this institution.

Very sincerely,
M. D. SULLIVAN,
Faithful Scribe

Knights of Columbus,
Council 1097,
Tower Road,
Halifax, N.S.

THE NAVY PLAYS

Shearwater Swim Winner

Shearwater captured the Atlantic Command swimming and diving championships during a recent weekend with a 105-point total.

Cornwallis finished second with 80 points and *Stadacona* trailed in third spot with 75 points at the meet staged at the *Shearwater* swimming pool.

Awards were presented to individual winners by Cdr. Roger Fink and Lt.-Cdr. R. H. Coell, of *Shearwater*, following the meet.

Navy Boxer on Olympic Team

A muscular, mild-mannered sailor who only a few months ago put on the boxing gloves after a six-year lay-off is the new Canadian amateur welterweight champion and will be this country's representative in his weight at the 1964 Olympic Games in Tokyo.

Ldg. Sea. Frederick Clyne (Des) Desrosiers, 24, of HMCS *Naden*, won the Canadian title and an Olympic Games berth with a series of clear-cut victories at Vancouver in late May. Yet, not so many months earlier, boxing was the furthest thing from his mind.

"Des" was born in Nelson, B.C., but spent most of his boyhood in Princeton, B.C. It was there, at the age of 13, he was introduced to boxing. A neighbour, Fred Fouty, a former RCN chief petty officer and boxer, had a well-worn punching bag and a continuing interest in the sport. Young Desrosiers started out as a keen pupil but his interest flagged after three years and he gave up boxing.

In 1958 "Des" joined the Navy and suddenly he was fighting again.

"They asked if anyone knew anything about boxing", he said. "I stuck up my hand."

That year "Des" reached the final of the Canadian light-middleweight division but his defeat there cost him the chance to compete in the British Empire Games, and he again deserted the ring.

It was during this "retirement", lasting six years, that "Des" married Caroline Jean Williams, of Princeton, and became the father of Pamela, 4, and Laurie 2.

His thoughts were far from boxing, but he reckoned without "Dusty" Gordon.

CPO Taylor Gordon for the past two years has been attached to the Maritime Command Pacific as electronic warfare adviser to the Staff Officer Communications. His interest in boxing dates from 1948.

"I'd been after Des for a year, but couldn't get him because he was at sea," said Dusty. "Then he was drafted to Marpac as a radar plotter. We had a few bouts in Victoria, then went into the B.C. Golden Gloves."

Again "Des" reached the finals and again he was stopped, this time by Edmonton's Milt Pahl. But now there was no thought of retirement. The lure of the Olympics was too strong. "Des" took three weeks' leave and spent it training in the *Naden* gym. To build his strength, he sawed logs.

On Friday, May 29, in Vancouver, "Des" had another chance at Milt Pahl. A combination of deadly right and left crosses, straight rights and left hooks put Pahl down twice in two rounds. When he staggered to his feet after the second count the referee declared him unfit to continue and awarded the decision to "Des" on a TKO.

The next afternoon "Des" won a unanimous decision over Albert Breau, of Quebec, and had reached the final again, this time against the defending Canadian welterweight champion, John Lapadula.

In the first round Lapadula was floored twice by a series of hard right crosses to the head. In the second round he decided that discretion was the better part of valour and managed to stay out of serious trouble. But "Des" Desrosiers saw him as a roadblock on the way to Tokyo that had to be removed. A left hook sent Lapadula to the canvas again at the beginning of round three. A right cross now opened a large gash over Lapadula's eye and left him in no condition to continue.

"Des" was the new champion and Canadian welterweight representative to Tokyo.

'Bonnie' Shares Wins with U.S. Ship

During HMCS *Bonaventure's* recent visit to Norfolk, Virginia, the American

aircraft carrier USS *Randolph* was hostess to the athletes from "Bonnie" in various sports.

Four assorted games were played, with each ship winning two. Of two softball games, the *Randolph* took the first encounter 6-3, but the "Bonnie" shook off her rustiness from prolonged inactivity and came back a few days later to win the game 13-10.

The "Bonnie's" volleyballers, well-conditioned from interpart play on board, blanked the *Randolph* 3-0.

The "Bonnie's" basketball team suffered its first loss this year, but gave a creditable showing against a smooth and rangy *Randolph* outfit, losing 44-32.

Radio Station Tops in Hockey

Albro Lake Naval Radio Station, for the second successive year, captured the *Stadacona* inter-part hockey championship. The Albro Lake team won the trophy by defeating Engineering Division 6-2 in a sudden-death final at the Halifax Forum.

Six teams competed in the *Stadacona* inter-part league.

Gloucester Gives To Olympic Fund

A \$100 donation to the Canadian Olympic Fund has been voted by the Welfare Committee of HMCS *Gloucester*. The donation from the Ship's Fund of the radio station was approved at a meeting of the Welfare Committee on July 2.

"We knew that the Canadian Olympic Fund was far short of its goal and we felt that this was a very worthwhile cause to which we could give some support," said Lt. J. A. Macdonald, executive officer at *Gloucester* and chairman of the Welfare Committee.

"We also thought that if we got the ball rolling, armed forces establishments across Canada would follow our lead and contribute, from their non-public funds, some of the cash that is sorely needed to send our Olympic team to Tokyo. This could go a long way toward providing the finances required to ensure Canada is properly represented.

"We also had in mind the fact that men from the armed forces, including a boxer from the Navy, had been selected for the team."

SCIENCE AND THE NAVY

Survey Ships Bear Heavy Load

The unending task of charting the seabed at home and overseas and new additional tasks, including oceanic exploration made necessary by the development of nuclear submarines, have "stretched to the limit" the Royal Navy's fleet of survey ships, states the Hydrographer of the Navy Rear-Admiral E. G. Irving, CB, OBE, RN, in his annual report.

With the contraction of Hydrographic responsibilities in colonial waters, he states, there has been a progressive expansion of oceanographical commitment and while the boundaries of the Empire continue to shrink, the frontiers of naval and scientific interest steadily advance.

Admiral Irving makes the following points about the demands made on his organisation:

- Increasing numbers of super tankers in the world's shipping lanes now call for a much more extensive knowledge of underwater topography;
- The growing quest for untapped fuel reserves beneath the sea is stimulating urgent interest in the shape, extent and composition of the continental shelves, and
- The development and operation of fast, deep-diving "true" submarines has rendered imperative the task of oceanic exploration and the accelerated construction programme of these vessels has this year both increased and added to its magnitude.

Since the scope of the Hydrographic department's activities are limited by manpower and money, it is essential that there should be some shedding of other commitments. It was to foster working liaisons and promote increased co-operation with foreign and Commonwealth hydrographic offices—and to encourage early assumption of fuller responsibilities on their part that the Hydrographer undertook a world tour in the spring of this year.

On this Admiral Irving reports that increased efficiency in hydrography and cartography can only be fostered by the pooling of information, ideas, experience and expertise. It was to this that he applied his efforts to ensure that the

quality of Admiralty charts should not be adulterated as they become more reliant on the work of local hydrographic agencies.

A new surveying fleet is being planned for the future. Three new ships have been ordered to take over from the Dampier class vessels—the *Cook*, *Dalrymple*, *Dampier* and *Owen*—for work in the deep oceans. Although designed for deep water oceanographical and hydrographic work, they will also be capable of surveying in coastal waters

and are to carry two large launches for independent inshore and harbour surveying operations.

Of merchant ship design and similar in many respects to the Royal Research ship *Discovery*, they will have a range and endurance to fit them for their specialised work. It is anticipated that they will have an overall length of 260 feet, a beam measurement of 49 feet and a draught of 15 feet. Their complement will be 19 officers and scientists and 98 ratings.—*Naval News Summary.*

SCALE DEFIES WAVES

A scale that will give an accurate reading on board ship of the weight of fish, despite stormy seas, is described in the current issue of NRC Research News, published by the National Research Council of Canada.

The scale, however, is not intended for the use of amateur anglers, who may prefer to have their own estimates accepted, but by fisheries scientists.

The principle of the scale's operation is outlined in NRC Research News article, which follows:

FISHERIES SCIENTISTS needed a precise method for weighing fish on the unstable platform provided by the deck of a research vessel. All existing scales were unsatisfactory when exposed to rolling, pitching and engine vibration. Eric Green of the Division of Applied Physics has evolved a relatively simple solution—a combination of two pendulum scales pivoted about a common axis to compensate for the movement of the sea.

The scale, shown here, is of the pendulum type, and uses the conventional eccentric cam and metal tape system. Both the pointer and the graduated scale itself are balanced by a pendulum, so that they both can move relative to the body of the scale and relative to each other. The system behaves, in effect, as if the weight of the object placed in the pan were divided into two portions which were weighed separately and then summed to give the total weight.

If the scale swings about its support, the two pendulum weights take up dif-

ferent positions and the yoke rotates on its pivot to adjust for the changes in tape length. Since the weight reading is relative to both pendulum system, it does not change.

In trials in a ship steaming 10 knots and pitching slightly every five seconds, this balance was able to weigh a five-pound fish to the nearest hundredth of a pound within five seconds. Even in very rough seas it weighed to the nearest 1/20 of a pound. Other ranges of sensitivity are now being explored.

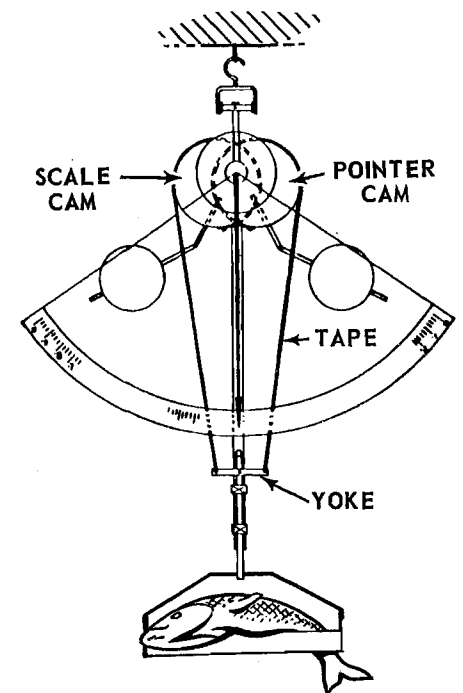

RETIREMENTS

CPO DONALD ROBERT ANDREWS, CD, C1FC4; joined RCNVR June 16, 1944; transferred to RCN Sept. 18, 1945; served in *Haligonian*, *York*, *Stadacona*, *Cornwallis*, *Scotian*, *Protector*, *Uganda*, *Nootka*, *Shearwater*, *Haida*, *Huron*, *Naden*, *Quebec*, *St. Laurent*, *Donnacona*, *Hochelaga*, *Restigouche*; retired June 15, 1964.

PO JOHN EDWARD CROOKS, CD, P2FC3; joined RCNVR Feb. 18, 1943; entered RCN March 25, 1946; served in Montreal naval division, *Stadacona*, *DEMS Montreal*, *DEMS Keydon*, *Cornwallis*, *Givenchy*, *DEMS Cardena*, *DEMS Burrard*, *DEMS Nimiskam Park*, *Givenchy*, *Dems Queens Park*, *Donnacona*, *Niobe*, *HMS Excellent*, *Haida*, *Nootka*, *Huron*, *Queen Charlotte*, *D'Iberville*, *Micmac*, *Sioux*, *Columbia*, *Chaudiere*; retired June 20, 1964.

CPO DONALD MURRAY HALVERSON, CD, C1LA4; joined June 9, 1944; served in *Haligonian*, *York*, *Stadacona*, *Naden*, *Royal Roads*, *Ontario*, *Bytown*, *New Liskeard*, *Cornwallis*, *Magnificent*, *Bonaventure*; retired June 8, 1964.

PO HERBERT LEONARD HERMAN, CD, P1ET4; joined RCNVR April 14, 1943; transferred to RCN Jan. 19, 1946; served in *Non-such*, *Naden*, *Nabob*, *Peregrine*, *Cornwallis*, *Givenchy*, *Prince Robert*, *Griffon*, *Uganda*, *Stadacona*, *Ontario*, *Antigonish*, *Beacon Hill*, *Rockcliffe*, *Crusader*, *Aldergrove*, *Sioux*, *Cayuga*, *Athabaskan*, *Cedarwood*, *Porte Quebec*, *Margaree*, *New Glasgow*; retired June 1, 1964.

PO HAROLD GEORGE HINCH, CD, P1ER4; served in RCNVR July 14, 1936-July 9, 1945; joined RCN Jan. 23, 1946; served in Halifax naval division, *Stadacona*, *Acadia*, *Chambly*, *Prince David*, *Sleepy Cove*, *Moose Jaw*, *St. Laurent I*, *Niobe*, *Louisburg*, *Scotian*, *Peregrine*, *Haligonian*, *Qu'Appelle*, *Scotian*, *Diving Tdr. No. 4*, *Haida*, *Iroquois*, *Athabaskan*, *Magnificent*, *Cornwallis*, *Micmac*, *Nootka*, *Quebec*, *St. Laurent II*, *Cayuga*, *Swansea*; retired June 14, 1964.

CPO DOUGLAS DAVID HOCKLEY, CD and 1st Clasp; C2ER4; joined RCNVR Sept. 7, 1939; transferred to RCN June 3, 1940;

served in *Stadacona*, *HMS Emerald*, *HMS Dominion*, *Georgian*, *Avalon*, *Scotian*, *Peregrine*, *Port Colbourne*, *Sackville*, *Nootka*, *Iroquois*, *Portage*, *Magnificent*, *Shearwater*, *Crusader*, *Cornwallis*; retired June 2, 1964.

CPO MALCOLM ANGUS McLEOD, CD and 1st Clasp; C1ER4; joined RCNVR Oct. 26, 1938; transferred to RCNR June 1, 1940 and to RCN, August 13, 1940; served in Vancouver naval division, *Naden*, *Nootka*, *Stadacona*, *Ottawa*, *Avalon*, *Niobe*, *HMS Jamaica*, *Peregrine*, *Cornwallis*, *HMS Towy*, *Givenchy*, *Rockcliffe*, *Discovery*, *Ontario*, *New Waterford*, *Magnificent*, *Stettler*, *Jonquiere*, *James Bay*; retired June 24, 1964.

CPO WILLIAM JAMES ROBERT MURRAY, C2LT4; joined RCNVR Sept. 21, 1938; transferred to RCN Sept. 10, 1945; served in Winnipeg naval division, *Naden*, *Cancolm*, *Crusader*, *Givenchy*, *Clayoquot*, *Venture*, *St. Hyacinthe*, *Stadacona*, *Ungava*, *Owen Sound*, *Avalon*, *Protector*, *Scotian*, *Rockcliffe*, *Ontario*, *Royal Roads*, *Cornwallis*, *Athabaskan*, *Montreal Circle radio station*, *Sussexvale*,



After a major reconstruction that took nearly five years, HMS Eagle is at sea again as Britain's most up-to-date aircraft carrier. The greatest outward change is the addition to the island of the 984 radar scanner. Down below tremendous changes have been made, including the installation of an inertial navigation system, ordinarily fitted only in submarines. (Photo courtesy British Information Services)

Aldergrove, Discovery; awarded RCN (R) Long Service and Good Conduct Medal; retired June 13, 1964.

CPO ALASTAIR NEWALL, CD; C2WA4; joined March 11, 1946, after serving in RCAF; served in *Tecumseh, Naden, Ontario, Stadacona, Niobe, HMS Gosling, RCNAS Dartmouth, Shearwater (19CAG), Magnificent (19CAG), Shearwater (30CAG), Naden, (VU33)*; retired June 28, 1964.

OFFICERS RETIRE

LT.-CDR (MAD) BOLEY HUBERT BAK, CD; commenced service in the RCN on June 17, 1935, as a probationary sick berth attendant; promoted to acting warrant wardmaster on June 1, 1942; served in *Naden, HMS Victory, Skeena, St. Laurent, Fraser, Stadacona, Protector, Cornwallis, Avalon, Magnificent, Shearwater*; last appointment, HMCS *Stadacona* for Canadian Forces Hospital, Halifax, as Hospital Stores and House-keeping Officer; commenced leave June 14, 1964; retires February 6, 1965.

LT.-CDR JOSEPH BEATTIE, CD; commenced service in the RCN on March 1, 1937, as acting engine room artificer, 4th class; promoted to acting warrant engineer on Jan. 1, 1944; served in *Naden, Fraser, Ottawa, Stadacona, Saguenay, Niobe, HMS Victory, HMS Black Prince, Kootenay, Protector, Sault Ste. Marie, Gatinneau, Sioux, Givenchy, Rockcliffe, Ontario, Bytown*; last appointment, HMCS *Naden* for Engineering Division; commenced leave June 25, 1964; retires on Feb. 3, 1965.

LT.-CDR. JOHN MORAN CALVER, CD; commenced service in the RCNR on Nov. 28, 1941, as a sub-lieutenant; demobilized Sept. 30, 1947; transferred to RCN as lieutenant-commander on March 15, 1951; served in *Stadacona, Eyebright, Chilliwack, New Westminster, Mayflower, Chaleur, Hochelaga, Donnacona, Bytown, Cedarwood, York, Sioux, Naden*, and in Vietnam; last appointment—HMCS *Naden* on staff of Maritime Commander Pacific as Staff Officer Shipping Control; commenced leave June 25, 1964; retires Nov. 12, 1964.

CDR. RICHARD JAMES DONNITHORNE, CD; commenced service in the RCNVR on May 5, 1938; as engine room artificer, 5th class; transferred to RCN Feb. 29, 1940; promoted to acting warrant ordnance officer on Aug. 1, 1943; served in *Stadacona, Assiniboine, Cornwallis, Chaleur, Hochelaga, Montcalm, Givenchy, Naden, Ontario, Cornwallis, Niagara, Niobe, PNO Quebec, Restigouche*; last appointment, *Hochelaga* as Superintendent Naval Armament Depot, Longueuil; commenced leave June 6, 1964; retires Jan. 1, 1965.

CAPTAIN PHILIP EDWIN HADDON, CD; commenced service in the RCN on Dec. 28, 1929, as a cadet; served in *Stadacona, HMS Erebus, HMS Valiant, HMS Victory, HMS York, HMS President, HMS Excellent, HMS Dryad, Saguenay, St. Laurent, Skeena, Ottawa, Royal Roads, Naden, Givenchy, Bytown, Avalon, Restigouche, Algonquin, Niobe, Niagara, Sioux*; last appointment HMCS *Niobe* as executive officer and as Chief Staff Officer to Naval Member Canadian Joint

CPO JOHN HENRY NICHOLLS, CD and 1st Clasp, C2ET4; served in London naval division, *Stadacona, Saguenay, Cornwallis, Georgian, Peregrine, Niobe, Warrior, Magnificent, Haida, La Hullose, Crescent, Quebec, Prestonian, Saguenay*; retired June 24, 1964.

PO ANTHONY NICHOLAS WITWICKI, CD, P1AW3; joined March 15, 1946; served in *Chippawa, Naden, Stadacona, Athabaskan, Cornwallis, Churchill, Sault Ste. Marie, Royal Roads, Sioux, Naden (VU33), Crescent, Bonaventure, Cape Scott*; retired June 22, 1964.

Staff London and as Canadian Naval Member to Military Agency for Standardization; commenced leave June 22, 1964; retires on March 2, 1965.

LT. ALBERT EDWARD HAWKINS, CD; commenced service in the RCN on Sept. 13, 1937, as a boy seaman; promoted to acting commissioned cookery officer on May 25, 1951; served in *Naden, Ottawa, Sans Peur, Stadacona, Royal Roads, Prince Robert, Chatham, Givenchy, Protector, Kings, York, Cornwallis, Bytown, Ontario, Shearwater Magnificent, Donnacona, Hochelaga*; last appointment, *Stadacona* as wardroom mess manager; commenced leave June 22, 1964; retires Feb 1, 1965.

CDR. BEVIS EBEN ELFRIC MILES, CD; commenced service in the RCNVR on Aug. 17, 1940, as acting sub-lieutenant; transferred to RCN Dec. 12, 1945, as lieutenant (L); served in *Stadacona, HMS Victory, HMS Seaborn, Venture, Bytown, St. Hyacinthe, Avalon, Niobe, HMS Punter, Uganda, Rockcliffe, Niagara, Athabaskan, Naden, Shearwater, Algonquin, Nootka, Haida, Iroquois*;

last appointment HMCS *Bytown* on secondment to Defence Research Board for duty with Directorate of Physical Research; commenced leave June 22, 1964; retires on Jan. 10, 1965.

LT. JACK MILLER, CD; commenced service in the RCN on Jan. 31, 1931, as acting engine room artificer, 4th class; promoted to acting warrant engineer on Jan. 1, 1944; served in *Stadacona, Skeena, Champlain, Saguenay, Fundy, Venture, Pugwash, St. Laurent, Sydney, Shediac, Avalon, Niobe, Chaudiere, Ottawa, Hochelaga, Thorlock, Magnificent*; last appointment, HMCS *Stadacona* on staff of Commodore Superintendent Atlantic for Ship Repair; commenced leave June 15, 1964; retires on March 9, 1965.

LT. REGINALD GARLAND SKINNER, CD; commenced service in the RCNVR, on Oct. 3, 1940, as a probationary victualling assistant; transferred to RCN as supply assistant Oct. 13, 1943; promoted to acting commission stores officer on Nov. 1, 1954; served in *Elk, Fort Ramsay, Peregrine, Cape Breton, Uganda, Rockcliffe, RCN College, Iroquois, Stadacona, Cornwallis, Naden, Ontario, Crusader, Athabaskan, Sioux, Beacon Hill, Quebec, Bytown, Shearwater, Bonaventure*; last appointment, HMCS *Shearwater*; commenced leave June 28, 1964; retires on Jan 21, 1965.

LT. ALBERT JOHN THORNTON, CD; commenced service in the RCNVR on March 14, 1933 as an ordinary seaman; transferred to RCN on 17 Dec., 1938; promoted to acting warrant stores officer on Sept. 1, 1948; served in *Naden, Malaspina, Stadacona, Venture, Skeena, Preserver, Avalon, Non-such, Discovery, Cornwallis, Niobe, Demetrius, Warrior, Magnificent, Shearwater, Bytown, Tecumseh*; last appointment, HMCS *Tecumseh* on staff of Area Recruiting Officer, Edmonton; commenced leave, June 14, 1964; retires on Jan. 17, 1965.



Now that summer rules the land, here is a reminder of the past—the first day of spring this year at HMCS *Stadacona*. That's "B" Block behind the drifts.

Naval Lore Corner

Number 128
JAPANESE ODDITIES

(BELOW) THE HUGE JAPANESE CARRIER "SHINANO" (71,890 TONS) WAS LAID DOWN AS A BATTLESHIP OF THE "YAMATO" CLASS AND CONVERTED INTO A CARRIER AFTER THE BATTLE OF MIDWAY. SHE COMMISSIONED ON 19 NOV. 1944 AND WAS SUNK 10 DAYS LATER BY THE U.S. SUBMARINE "ARCHERFISH." HER HUGE FUNNEL SLANTED OUTBOARD AT AN ANGLE OF 26°. SHE HAD STOWAGE FOR ONLY 47 AIRCRAFT, BUT WAS DESIGNED TO PROVIDE A HUGE ARMoured "EXTRA" FLIGHT DECK FOR OTHER CARRIERS AND FOR SHORE-BASED AIRCRAFT...

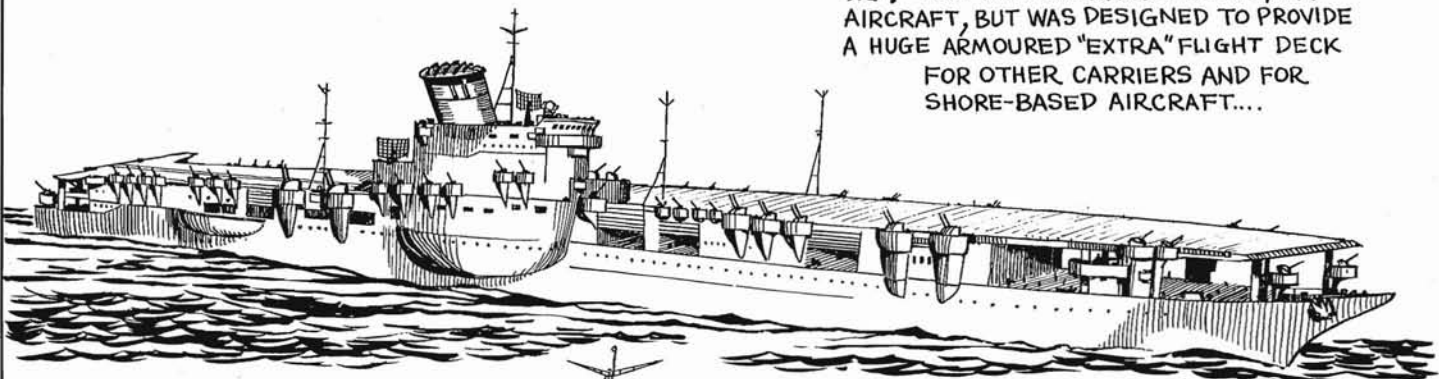

THE CRUISER "OYODO" (11,435 TONS) WAS DESIGNED AS A FLAGSHIP FOR A HUNTER FORCE OF SUBMARINES AND RECON. PLANES. THE AIRCRAFT, TO BE STOWED IN HER HANGAR (6 OF THEM) WERE TO LOCATE TARGETS FOR THE SUBMARINES AND "OYODO". SHE WAS LIGHTLY ARMoured, MOUNTED SIX 6.1 INCH GUNS WITH TOP SPEED OF 35.3 KNOTS. COMMISSIONED IN FEB. 1943, NO SUITABLE AIRCRAFT WERE AVAILABLE AND SHE NEVER SERVED IN HER DESIGNED ROLE. SHE WAS SUNK IN JULY, 1945...

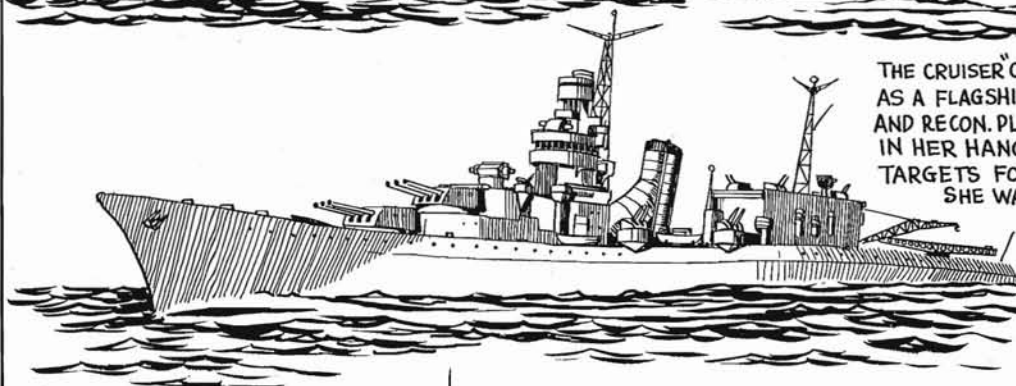

THE LARGEST NON-NUCLEAR SUBMARINES EVER BUILT WERE THE 4 JAPANESE GIANTS 'I400, I401, I402 AND I404' (5,222/6560 TONS, 400 FEET OVER ALL). THEY CARRIED ONE 5.5 INCH GUN, EIGHT TORPEDO TUBES AND 3 SEAPLANES. THE CONNING TOWER WAS SET TO PORT WHILE A LONG HANGAR FLANKED IT TO STARBOARD...

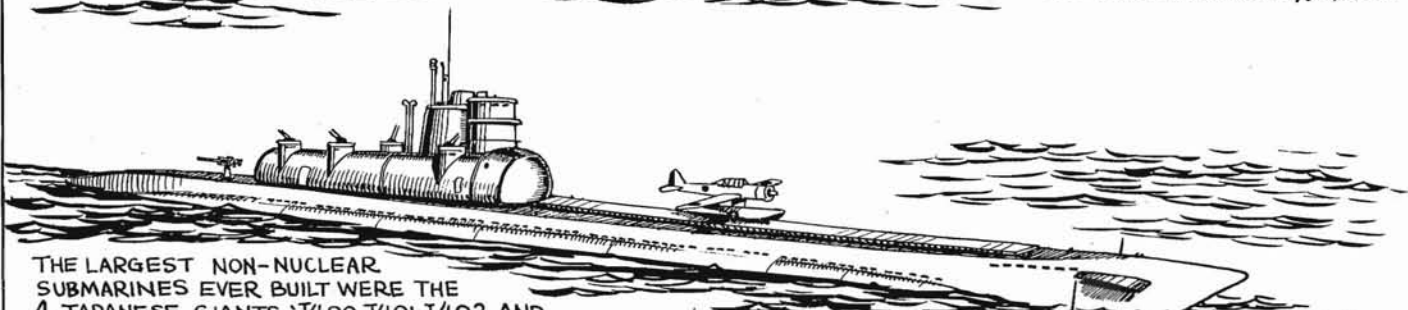

THE LIGHT CRUISER "YUBARI" (1923) WAS AN UNIQUE ATTEMPT TO COMBINE A CRUISER'S ARMAMENT ON A DESTROYER DISPLACEMENT. SHE MOUNTED SIX 5.5 INCH GUNS AND 4 TORPEDO TUBES ON A DISPLACEMENT OF 2890 TONS. THOUGH SUCCESSFUL, THE DESIGN WAS NOT REPEATED...

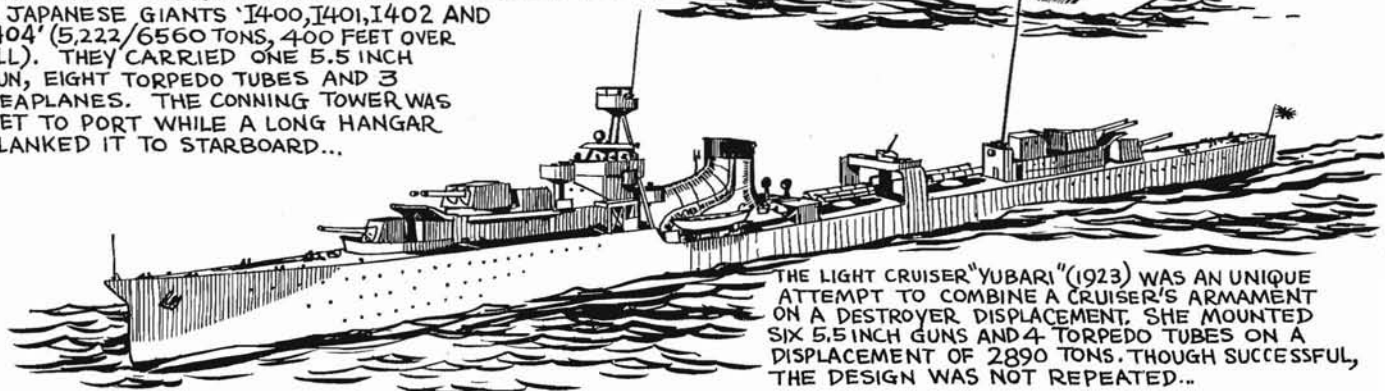

CANADA
POSTAGE PAID
PORT PAYÉ

*If undelivered,
return COVER WITH CONTENTS to:*

The Queen's Printer, Ottawa, Canada

*En cas de non-livraison,
retourner cette PUBLICATION INTACTE à:*

L'Imprimeur de la Reine, Ottawa, Canada



The CROWSNEST



Vol. 16, No. 67

August, 1964

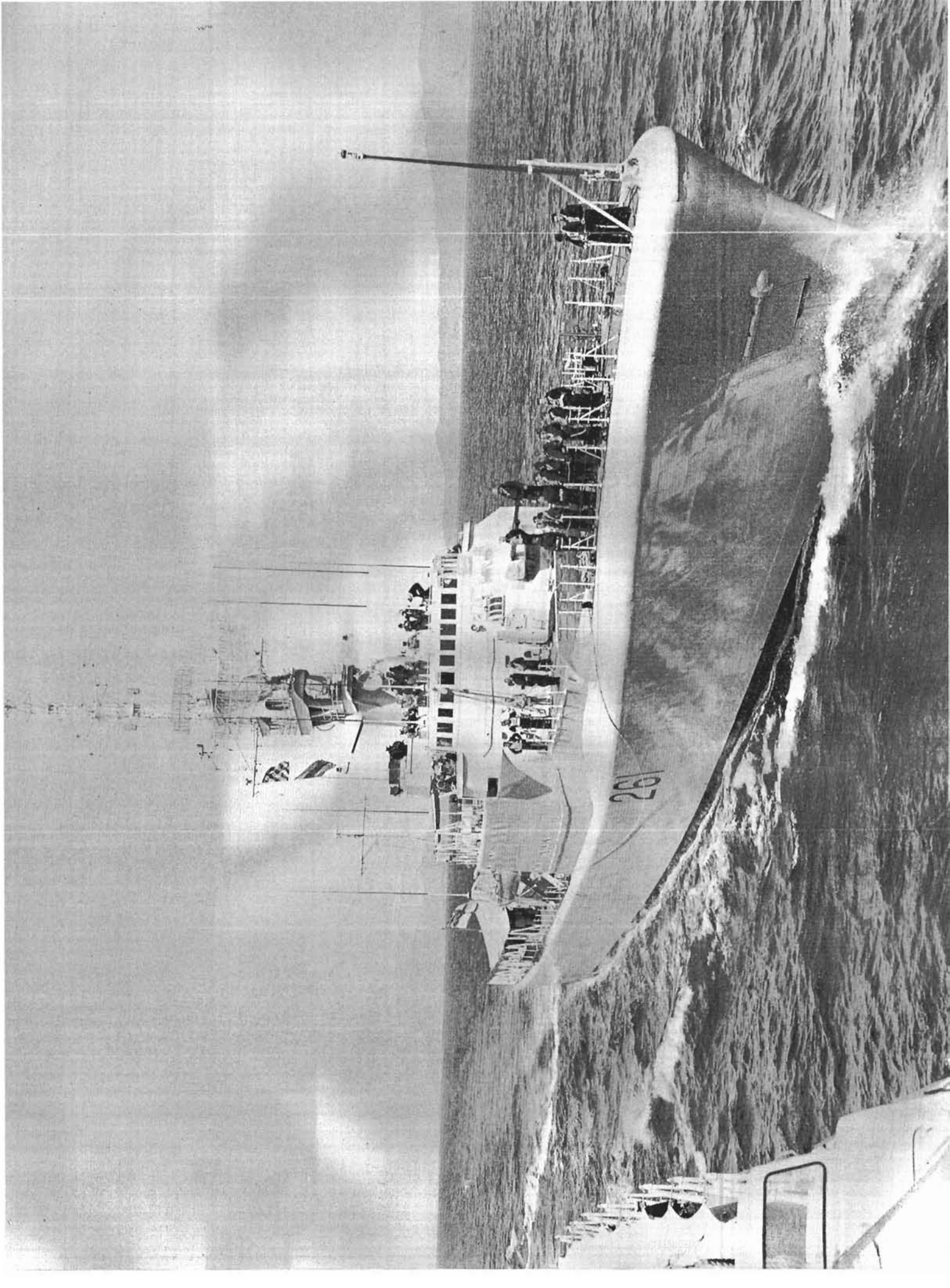

The CROWSNEST

Vol. 16 No. 8

THE ROYAL CANADIAN NAVY'S MAGAZINE

AUGUST 1964

CONTENTS

	Page
RCN News Review	2
CNS Retires	5
Integration	9
Easter Island Expedition	12
The Cyclic System	13
Officers and Men	17
Weddings and Births	17
Long Way Round (Part IV)	21
In Memory	24
Retirements	27
Naval Lore Corner No. 129	Inside Back Cover

LADY OF THE MONTH

A jackstay transfer off Vancouver Harbour provided the opportunity for this dashing picture of HMCS *Mackenzie* as she approached HMCS *Qu'Appelle* from astern. Actually, a triple jackstay transfer was accomplished, the other participating ship being the *Margaree*.

The three ships demonstrated their skills to a group of Vancouver businessmen as part of the ships' participation in the Vancouver Maritime Festival in June.

The *Mackenzie*, name ship of her class, was commissioned at Montreal in October 1962 but now is firmly established as a member of the Pacific fleet. (E-77352)

Negative numbers of RCN photographs reproduced in *The Crowsnest* are included with the caption for the benefit of persons wishing to obtain prints of the photos.

This they may do by sending an order to the Directorate of Naval Photography, Canadian Forces Headquarters, Ottawa, quoting the negative number of the photograph, giving the size and finish required, and enclosing a money order for the full amount, payable to the Receiver General of Canada.

Sizes, finish and the National Defence standardized prices, follow:

Sizes, finish and the National Defence standardized prices, follow:

4 x 5 (or smaller) glossy finish only ..	\$.10
6½ x 8½ glossy finish only40
8 x 10 glossy or matte finish50
11 x 14 matte finish only	1.00
16 x 20 " " "	3.00
20 x 24 " " "	4.00
30 x 40 " " "	8.00

SUBSCRIPTION RATE

The Crowsnest may be subscribed for at the rate of \$2 a year; outside of North America, \$3. Orders, accompanied by cheque or money orders payable to the Receiver General of Canada, should be sent to:

THE QUEEN'S PRINTER,
OTTAWA, Ontario,
Canada

Communications, other than those relating to subscriptions, should be addressed to:

EDITOR,
The Crowsnest,
Canadian Forces Headquarters,
OTTAWA, Ontario.

The Cover—Following her commissioning at Sorel, Que., May 30, HMCS *Nipigon* had the rare, if not unique, privilege of breaking out two notable flags. One was the personal flag of His Excellency, the Governor-General. The other was the flag of the Naval Board of Canada, a golden anchor on a diagonally divided flag, blue to the mast and red to the fly, modelled on the flag of the Lord High Admiral. The Governor General's flag (signifying the presence on board of His Excellency) has frequently been flown in HMC Ships; the Naval Board flag, flown when two or more members of the Naval Board are embarked, has been broken out a number of times over the years. But seldom, if ever, have the two been worn by the same ship at the same time. Adding to the historic aspect of the occasion was the possibility that, with the Naval Board dissolved in August, this may have been the last time for the Naval Board flag to be flown by a Canadian warship.



RCN NEWS REVIEW

The high-speed attack submarine USS Tang and HMC Ships Mackenzie and Qu'Appelle share space at Centennial Pier in Vancouver during that city's Maritime Festival in June. (E-77332)

Commons Group Views Defences

Nineteen members of the Special Committee on Defence, accompanied by Hon. Lucien Cardin, Associate Minister of National Defence, visited the Canadian Maritime Command Atlantic, July 27-30.

The Parliamentarians took off for Halifax from Ottawa by RCAF transport on Monday and that day toured the RCN Air Station, *Shearwater*, HMC Dockyard, *Stadacona* Fleet School, HM Submarine *Alcide*, aircraft carrier *Bonaventure* and were accommodated overnight in various warships alongside.

On the Tuesday, they witnessed destroyer-helicopter operations on board HMCS *Assiniboine*, then visited the fleet replenishment ship *Provider*. In the afternoon they were briefed on the Maritime Commander's operations and the RCAF Air Officer Commander's contribution to maritime activities. Later there were high level briefings in the Joint Maritime Warfare School on the responsibilities of the Flag Officer Atlantic Coast and his NATO appointment, Commander Canadian Atlantic Sub Area.

On Wednesday, the committee members embarked in two RCAF *Argus* for a flight to Bermuda where they joined three of the Fifth Escort Squadron's destroyer escorts in "OTT 2/64", and watched one of the serials in which air

and sea elements were co-operating in anti-submarine warfare practice. Besides the ships, a Navy Tracker and HM Submarine *Auriga* were "on stage" for the parliamentarians.

Thursday, the final day, was spent in Norfolk, Virginia, for a briefing by

Admiral Harold Page Smith, USN, Supreme Allied Commander Atlantic. Another briefing by Vice-Admiral Charles E. Weakley, USN, Commander U.S. Anti-Submarine Warfare Forces, Atlantic, was prolonged at the request of the Defence Committee at the expense of a tour of navy bases.

Admiral Weakley spared no trouble to oblige and handled all possible questions while the committee was assembled in the carrier USS *Randolph*, alongside at Norfolk.

The tour ended that evening with the return of the travellers to Ottawa.

Naval Aviation Half-Century Old

The Royal Naval Air Service was established as a separate entity on July 1, 1914, and, in recognition of the 50th anniversary of naval aviation, a Fleet Air Arm Museum was opened in May at Yeovilton, England.

The Admiralty Board sent its good wishes "to past and present officers and men of the Fleet Air Arm in recognition of their great contribution to the achievements of the Royal Navy."

The RNAS had its origin in the naval wing of the Royal Flying Corps, which was established on May 13, 1912, with naval and military wings.

A reunion was held at Yeovilton on May 28 and greetings were sent by Vice-Admiral H. S. Rayner, Chief of the Naval Staff, in the following words:

"On behalf of the Royal Canadian Navy I would like to extend greetings and hearty congratulations on the occasion of the 50th anniversary of naval aviation in the Royal Navy together with best wishes for the next 50. The thoughts of many Canadian aviators will be with you at the reunion being held at Yeovilton."

Haida to Become Floating Museum

HMCS *Haida*, most famous fighting ship in the 54-year history of the RCN, will become the first Canadian warship preserved in this country for posterity.

Haida Incorporated, a syndicate of Toronto businessmen, bought her this summer for an announced \$20,000 and will convert her to a floating museum on the Toronto waterfront.

The 2,800-ton destroyer escort is a storied veteran of the Second World War and the Korean conflict. She was paid off as surplus in October at Halifax in her 21st year and later towed to Sydney. She was taken from there for delivery to the syndicate at Sorel in August. On arrival in Toronto, she will be restored to her wartime appearance.

A commercial pilot with no previous naval connections got the ball rolling to preserve this fighting lady. Neil Bruce had a short cruise in the *Haida* during which her history got into his blood. Since then he has travelled thousands of miles, attended numerous meetings and piled up phone bills "like the national debt" to achieve her preservation.

Aiding in negotiations for the destroyer was Vice-Admiral H. G. DeWolf, a retired Chief of the Naval Staff. He was her wartime captain and for overseas action was awarded the DSO, DSC and four mentions in despatches. After the war he was appointed CBE, awarded the U.S. Legion of Merit (Degree of Officer), French Cross of the Legion of Honour (rank of officer) and the Norwegian King Haakon VII Cross of Liberation.

The *Haida*, built in Britain, was commissioned in 1943, served in Murmansk convoys, then with a mixed Canadian-British destroyer flotilla in the English Channel. Admiral DeWolf, then com-

Stern Warning Given in Gaelic

Not all history books record the tale, but it is said that King James I of England, who was also King James VI of Scotland, carried out some interesting research on the origin of language.

He placed two infants in the care of a deaf-mute nurse on an island off the coast of Scotland, out of all touch with other members of the human race.

Fifteen or 20 years later, he brought the little group back to the mainland and—what do you know?—the brother and sister spoke perfect Gaelic, the language of the Garden of Eden.

Not only was Gaelic spoken in the Garden, it is spoken today in that other Eden, Cape Breton Island. This is the logical reason for the following inscription on the safety record bulletin board at Point Edward Naval Base, Sydney, N.S.:

"DAOINE GUN TUR'S CEANN AOBHAR DO SSIORRAIDHEAN NEO-RIATANACH"—or something to that effect, of which the English translation is "Foolish men cause needless accidents."

According to Cdr. E. B. Morris, Base Superintendent, the great majority of naval civilian personnel at Point Edward Naval Base are of Gaelic Highland Scottish extraction.

What prompted Cdr. Morris to draw attention to the wording of the safety record board were the somewhat loaded remarks of Robert Muir, MP for Cape Breton North and Victoria, to Associate Defence Minister Lucien Cardin in the House of Commons on the subject of a second language in the Armed Forces: "May I suggest to the minister that I hope Gaelic will be considered to be an asset in the services?"



Architect's drawing of the new Oshawa Naval Veteran's Club which was opened recently.

mander, put 14 notches on her bridge rail as a result of surface actions with the enemy. She helped sink a U-boat as well.

Canadian Sailors In Royal Yacht

At the invitation of Her Majesty the Queen, one officer and six men of the RCN will serve in HM Royal Yacht *Britannia* during the Royal Visit to Prince Edward Island and Quebec in October.

They are:

Lt. Ronald Stuart Binnie, *Mackenzie*; Ldg. Sea. Harry Ruppel, signalman in the *Jonquiere*; Ldg. Sea. Ivor Edward MacLeod, cook in the *St. Croix*; AB Earl Edward Pederson, boatswain in the *Mackenzie*; AB John Stanley Gormely, engineering mechanic in the *Assiniboine*; AB Roland J. P. Robitaille, engineering mechanic in *Outremont*, and AB Abbie R. Eddy, boatswain in the *Columbia*.

Selection, consistent with rank and trade requirements of the Royal Yacht, was on a regional basis. The Canadians, all volunteers, will join the *Britannia* at Portsmouth, England, on Sept. 7 and will remain on board as part of the ship's company for about three months.

The *Britannia* is commanded by Rear-Admiral Sir Joseph Charles Cameron Henley, KCVO, CB, Flag Officer Royal Yachts.

Canadians were included in the *Britannia*'s complement for the 1959 Royal Tour of Her Majesty and His Royal Highness the Prince Philip.

Her Majesty will deliver an address in the Quebec Legislature October 10 to mark the centennial of the pre-Confederation Quebec Conference of the Fathers of Confederation. Four days

earlier, Her Majesty will have officially opened the new Fathers of Confederation Memorial Buildings in Charlottetown, unveiling a plaque commemorating the event.

Details for the subsequent visit to Ottawa were not announced immediately.

At Quebec, Her Majesty will also attend a military ceremony marking the 50th Anniversary of the founding of the Royal 22nd Regiment, the famous "Van Doos", of which she is Colonel-in-Chief.

Fraser Rescues Drifting Craft

A Canadian warship came to the rescue of a stricken United States oceanographic vessel in the Pacific Ocean off the coast of Mexico in mid-July.

HMCS *Fraser* based at Esquimalt took the 100-foot *Yaqui Queen* in tow after her engines broke down 150 miles off the coast of lower California.

The *Fraser*, on a training cruise, towed the oceanographic ship to Mazatlan, Mexico.

The *Yaqui Queen*, on charter to the U.S. government, had been drifting for 12 hours. She had a crew of five and three oceanographers on board.

11th Oberon Sub in Service

The *Naval News Summary* for June reports that the 11th Oberon class submarine, HMS *Opossum*, was commissioned June 5 at the Cammell Laird Shipyard, Birkenhead. She is the 19th developed from HMS *Porpoise*, which entered service six years ago.

The report calls attention to her joystick control gear. A petty officer sits in a padded chair at "a console remi-

niscent of a bomber's flight deck". The joystick control gear is more formally known as the "one-man ship-control unit" and is the British equivalent to the American system. The course and depth of the submarine are controlled and an automatic steering and depth keeping device are incorporated. This automation means a reduction in numbers to "drive" the boat, the *Opossum* complement being six officers and 57 men.

All Oberon class submarines but the first one have the joystick control gear, including the three Oberon class being built at HM Dockyard, Chatham, for the RCN, the *Ojibwa*, *Onondaga* and *Okanagan*.

The petty officer at the console has his padded chair while the officer of the watch makes do with a backless stool, since he must keep a watching brief of the whole compartment.

Captain William B. Christie has been appointed to Chatham, England, as Canadian Naval Submarine Technical Representative for the RCN's Oberon class submarine building program.

Captain Christie formerly was Director of Submarine Production at Naval Headquarters, Ottawa.

Donnacona Band Festival Winner

The band of HMCS *Donnacona*, Montreal naval division, won top honours in an Independence Day festival at Rouses Point, N.Y., on July 6.

Led by Lt. J. E. Carviel, bandmaster, and Petty Officer John McBain, drum major, the band won first prize for best military style and first prize as best overall band in the parade.

Fifteen bands participated, including others from Montreal and the northern New York area. The festival was organized by the Rouses Point branch of the U.S. Legion.

Donnacona's band accompanied a contingent of the RCMP.

Communications Centre Opened

No. 7 Communications Unit, St. John's, Nfld., was officially opened on July 31 by Col. H. E. C. Price, Commander Newfoundland Area.

The unit is commanded by Flt. Lt. D. A. Tite, RCAF, and is manned by Canadian Army and RCAF personnel. It will pass administrative and operational messages for the RCN, Army and RCAF and will transfer similar traffic for the United States services.

LETTERS

Dear Sir:

Last November a reunion dinner of ex-*Conway* cadets was held in Toronto at the Royal Canadian Military Institute, attended by 18 ex-cadets. Thirty-two *Conways* were contacted for the event in the Toronto, Ottawa and Montreal areas.

It is intended to hold another dinner in early November at the Royal Canadian Military Institute and we are anxious to contact as many ex-cadets as possible. We would therefore appreciate any assistance you can give us through *The Crowsnest* by mentioning the dinner in your publication.

If any ex-cadets from the training establishments *Worcester* or *Pangbourne* would care to attend, they are most cordially invited.

Details of the arrangements will be issued at a later date. However, those interested should contact

J. A. Mitchell,
Lt.-Cdr. RCNR (Ret),
PO Box 41,
Whitby, Ont.

Thanking you,

Yours very truly,

J. A. MITCHELL

Sir:

I am writing on behalf of White Ensign Branch, No. 129, Royal Canadian Legion. Our branch is the only one in Canada which is 100 per cent ex-naval personnel.

We are collecting cap ribbons of ships long gone and ships of the present. Ships of the present, so far, have not posed any problem but getting ribbons of ships that have gone is a problem. If any of the readers of *The Crowsnest* have any old cap ribbons they would like to donate, we would be most appreciative.

Many of your readers will probably remember me—"Nobby" Hayward, ex-CPO, TGM. I was always accused of being a "scrounger". With this thought in mind, I am asking ex-naval personnel to look in their old ditty boxes or cap boxes to see whether or not they have any old cap ribbons, and who knows they might even come up with a ship's badge, which we would be delighted to hang on the walls of our club room. All donations will be acknowledged.

Please address all correspondence to me at the below address.

Yours sincerely,

ALBERT F HAYWARD

White Ensign Branch,
Royal Canadian Legion,
726 Gottingen Street,
Halifax, N.S.

Divers Buy Former Tender

Two Halifax commercial divers have bought the ex-*YMG 187* in which they trained and served as naval divers several years ago. Fleming Vemb and Vince Patcheson are converting the concrete-hulled tender to a combined depot ship and houseboat they will moor in Bedford Basin.

Vemb, aged 34, is a Copenhagen-born, third-generation diver who dived for the Germans in the Second World War. He signed on for a hitch in the RCN in 1955, and married a Halifax girl. They and six children will live in the houseboat, with bachelor quarters on board the 900-ton vessel for partner Patcheson.

YMG 187 was a gate vessel holding up part of the wartime anti-submarine net protecting Shelburne harbour. Later she was a diving tender and then lay at the minesweeping base facility in Halifax, declared surplus. The original buyer from Crown Assets found it too costly to tow her to his Shelburne County beach, so the Vemb-Patcheson firm, who in three years have established themselves in several Nova Scotian salvage jobs, took her over. A turn of the wheel for men and vessel!

NAVAL RECORDS CLUB FORMED

The recent formation of a Naval Records Club to help naval enthusiasts to gather information on ships of all nations, ancient and modern, is drawn attention to in a letter from E. C. Fisher, secretary of the club, 726 North Reynolds Road, Toledo, Ohio 43615, U.S.A.

Mr. Fisher says the \$3 annual membership covers the cost of the club's monthly journal, *Warship International*, which carries articles on naval history and accounts of warships, both current and historical. For example, the June issue carried articles on the loss of *HMS Exeter* and on USN battle cruiser development.

The journal publishes lists of technical and historical facts on ships and fleets, has a ship modeller's page and a news column on current naval developments.

CNS RETIRES

"We wish to express our personal appreciation and that of the government and people of Canada for Admiral Rayner's outstanding service to our country."

THESE WORDS appeared in the joint announcement by Hon. Paul Hellyer, Minister of National Defence, and Hon. Lucien Cardin, Associate Minister of National Defence, of the retirement of Vice-Admiral H. S. Rayner on completion of his four-year term as Chief of the Naval Staff.

The announcement spoke of Admiral Rayner's outstanding service in the Battle of the Atlantic and noted that during his post-war service he had established several "firsts". He was the first commandant of Royal Roads when it became a tri-service college; the first officer to serve as co-ordinator of the Joint Staff at National Defence Headquarters and the first officer to hold the appointment of Canadian Maritime Commander Pacific, when RCAF and RCN elements on the West Coast were integrated into a single maritime force in 1959.

"In all his appointments, culminating in that of Chief of the Naval Staff, Admiral Rayner's leadership, ability and devotion to duty have been of the highest order. His personal qualities and example have commanded the admira-

tion of all who have met him in the course of his distinguished career," the statement concluded.

Admiral Rayner's career almost precisely spanned the period during which the Royal Canadian Navy was headed by a Chief of the Naval Staff.

Rear-Admiral Walter Hose, who retired on June 30, 1934, and who resides at Riverside, Ont., a suburb of Windsor, became the RCN's first Chief of the Naval Staff on March 7, 1928, having previously held the title of Director of the Naval Service.

Admiral Rayner entered the RCN as a cadet exactly six months later, on Sept. 7, 1928, to begin a naval career that was to culminate in his service as the RCN's last Chief of the Naval Staff.

Herbert Sharples Rayner was born on Jan. 16, 1911, at Clinton, Ont. He received his early education at St. Catharines, Ont.

Following his entry into the Royal Canadian Navy as a cadet in 1928, he trained with the Royal Navy and later served in various ships of the RN, including the battleships *Revenge* and *Warspite*. He returned to Canada in July 1933 to serve almost two years in the destroyer *Champlain* before going back to the United Kingdom for further courses and training. After his return to Britain he saw service in the battleships *Rodney* and *Nelson*.



VICE-ADMIRAL H. S. RAYNER

In August 1937 he was appointed to HMCS *Skeena*, River class destroyer, as first lieutenant and was serving in this appointment when the Second World War broke out. He temporarily commanded the *Skeena* in February 1940 and was appointed in command of the destroyer *St. Laurent* in July 1940. From then until early in 1941 the *St. Laurent* was based at United Kingdom ports, escorting convoys in the eastern Atlantic and the approaches to the British Isles. His services earned the Distinguished Service Cross "for courage and enterprise in action against enemy submarines."

The particular action occurred in December 1940 when a convoy came under attack of several U-boats. At

A Farewell from the West Coast Press

Vice-Admiral H. S. Rayner is always assured of a hearty welcome in this city which knows him well and favourably, but there is special significance to his current farewell review of the RCN's Pacific Command. Consequent on the new alignments at defence headquarters his impending retirement means that he will be the last of the long roll of designated chiefs of naval staffs.

This adds to the normal piquancy of a visit by the professional head of the country's senior service, and especially so when the incumbent of this high responsibility is an officer widely esteemed and admired both within and without the navy in which he has forged a notable career spanning 36 years.

It is as a familiar of the Esquimalt station, of course, that Admiral Rayner will this weekend renew his intimacy with the officers and men of the Pacific Coast, whom he will find in the fine state of efficiency that marked his own tenure as flag officer here, the

appointment from which he left four years ago to assume the topmost post in the RCN. He is remembered on local circles also as a former commandant of the Royal Roads tri-service college.

These are links that tie him to his community and illustrate the qualities that ensured his steady upward progress in his country's service. He was a destroyer captain of vigorous pursuit during the war and successively he filled with customary aptitude and acute mind the staff posts that lead to senior naval command.

Not only is Admiral Rayner an officer of unusual attainment in his professional capacities but he is an individual of engaging personal worth who wins loyalty as well as respect, and his retirement means that the navy and the nation loses a chief of staff whose counsel and advice has been of great value to the defence department.

(From an editorial in *The Victoria Colonist*, July 10, 1964).



The Naval Board of Canada met for the first time on Feb. 9, 1942, in the old Aylmer building, torn down shortly after the Second World War to make way for the approaches of the Mackenzie King bridge across the Rideau Canal in Ottawa. At the first meeting, clockwise from lower left, were: Paymaster Cdr. R. A. Pennington, RCNVR, Secretary to the Naval Board; Captain H. T. W. Grant, Chief of Naval Personnel; Commodore 1st Class H. E. Reid, Vice-Chief of the Naval Staff; Vice-Admiral P. W. Nelles, Chief of the Naval Staff; Hon. Angus L. Macdonald, Minister of National Defence (Navy); W. Gordon Mills, Deputy Minister of National Defence (Navy), financial and civil member of the board; Engineer Captain G. L. Stephens, Chief of Naval Engineering and Construction, and Captain G. M. Hibbard, Chief of Naval Equipment and Supply. Only three of those shown in the picture are living: Vice-Admiral Grant, Rear-Admiral Stephens and Commodore Hibbard, all of whom have been retired for some years. (NP-260)

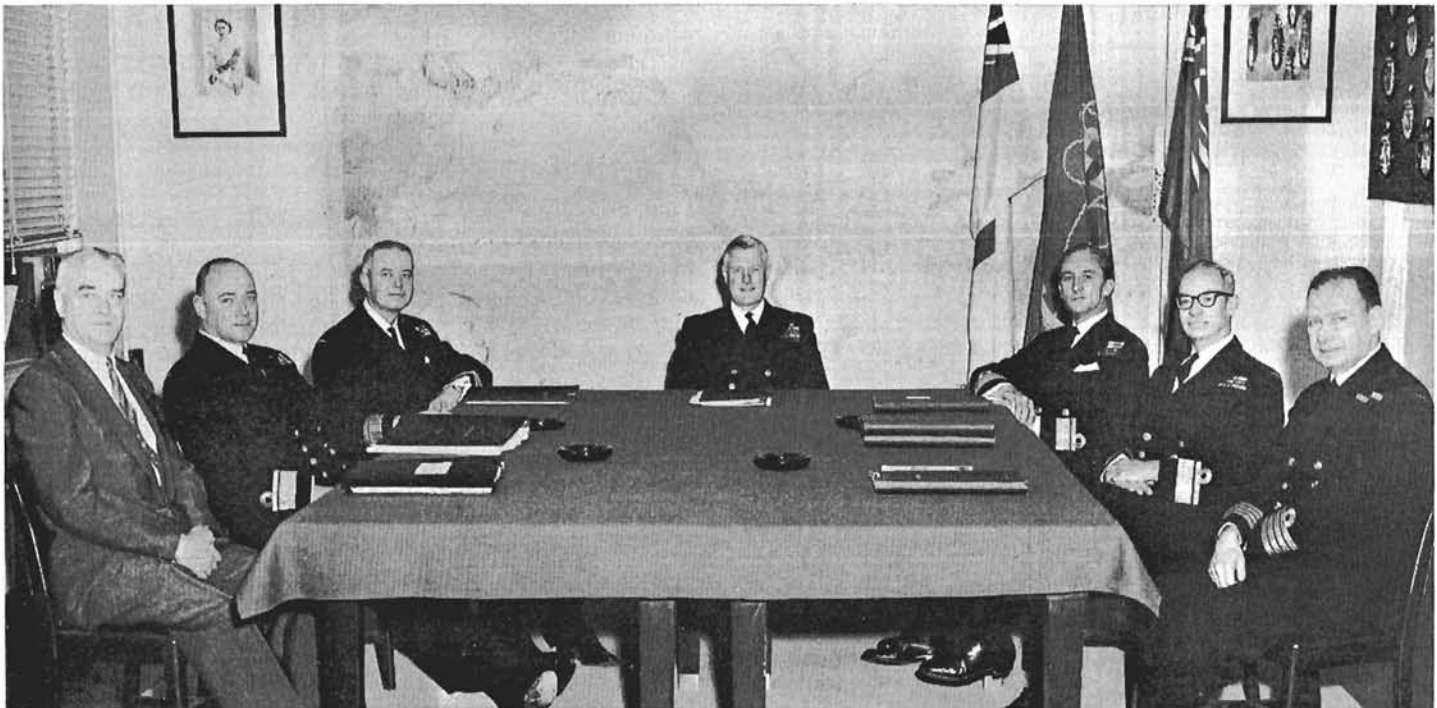

The days of the Naval Board of Canada were numbered when this last picture of its five members and secretariat was taken in the board room at Naval Headquarters in June. From left are: R. A. Stead, Deputy Naval Secretary; Rear-Admiral J. B. Caldwell, Chief of Naval Technical Services; Rear-Admiral K. L. Dyer, Vice-Chief of the Naval Staff; Vice-Admiral H. S. Rayner, Chief of the Naval Staff; Rear-Admiral M. G. Stirling, Chief of Naval Personnel; Rear-Admiral C. J. Dillon, Naval Comptroller, and Captain A. O. Solomon, Secretary, Naval Board. (O-15579A)

The RCN's Chiefs of the Naval Staff

In the 54 years of the Royal Canadian Navy's existence, eight of the nine men at the head of the RCN have borne the title of Chief of the Naval Staff. The first professional head was Admiral Sir Charles E. Kingsmill, Kt, RN (Ret), appointed on May 5, 1910, and entitled Director of the Naval Service of Canada.

Rear-Admiral Walter Hose, CBE, RCN, succeeded Admiral Kingsmill on January 1, 1921. The title of the office was changed to Chief of the Naval Staff on March 7, 1928.

Admiral Percy W. Nelles, CB, RCN, the only officer of the Royal Canadian Navy ever to attain that rank, became Chief of the Naval Staff on July 1, 1934.

Vice-Admiral George C. Jones, CB, RCN, was appointed CNS on Jan. 15, 1944, at which time Admiral Nelles became Senior Canadian Flag Officer

Overseas and, subsequently, Head of the Canadian Naval Mission Overseas.

The sudden death of Admiral Jones on Feb. 8, 1946, was followed by the appointment of Vice-Admiral Howard E. Reid, CB, RCN, as Chief of the Naval Staff on Feb. 28, 1946.

Admiral Reid held the appointment for about a year and a half and was succeeded on Sept 1, 1947, by Vice-Admiral H. T. W. Grant, CBE, DSO, CD, RCN.

Vice-Admiral E. R. Mainguy, OBE, CD, RCN, became Chief of the Naval Staff on Dec. 1, 1951.

His successor was Vice-Admiral Harry G. DeWolf, CBE, DSO, DSC, CD, RCN, who became CNS on Jan. 16, 1956.

The Royal Canadian Navy's eighth and last Chief of the Naval Staff, Vice-Admiral Herbert S. Rayner, DSC and Bar, CD, RCN, assumed office on Aug. 1, 1960, relinquishing the appointment on July 20, 1964.

dawn the *St. Laurent* attacked a surfaced submarine. In company with HMS *Viscount*, the *St. Laurent* continued the attack until 3 p.m., then picked up the survivors of a torpedoed merchant vessel and escorted a damaged ship back to England.

Vice-Admiral Rayner came ashore in February 1942 and until May 1943 served as Staff Officer Operations to the Commanding Officer Atlantic Coast, at Halifax.

Vice-Admiral Rayner commissioned HMCS *Huron*, Tribal class destroyer, in July 1943 and commanded the ship during convoys to northern Russia. One of these was the convoy which came under attack by the German battle cruiser *Scharnhorst* before the latter was engaged and sunk by British capital ships.

The *Huron* next operated in the English Channel and the Bay of Biscay before and after D-Day. For his services during this period, Vice-Admiral Rayner was twice mentioned in despatches and received a bar to the DSC.

The second award of the DSC arose out of an action at the western end of the English Channel in which HM Ships *Tartar* and *Ashanti* and HMC Ships *Haida* and *Huron*, along with other ships of the 10th Destroyer Flotilla, joined forces in an encounter with five German destroyers attempting to break through to attack the Allied invasion fleet off Normandy. Four hours after the initial radar detection, one German destroyer was driven aground in flames while the others had been sunk or forced to flee back to Brest.

Later in the month the *Huron's* guns set fire to a German minesweeper and blew up an armed trawler.

Vice-Admiral Rayner's wartime services received further recognition in September 1946, when the French government awarded him the Croix de la Légion d'Honneur with the rank of Chevalier, and the Croix de Guerre with Palm.

In September 1944 he was appointed to naval headquarters as Director of Plans, and in December 1945 he became Captain (D) at Halifax. He took command of HMCS *Nootka* (destroyer) in August 1946, then in June 1947 was appointed in command of the RCN Air Section, Dartmouth, N.S.

In August 1948 Vice-Admiral Rayner became commandant of the Canadian Services College, Royal Roads. A year later he went overseas to attend the Imperial Defence College, London.

In January 1951 he was appointed Secretary to the Chiefs of Staff Committee at National Defence Headquarters, a post later changed to Co-ordinator of the Joint Staff. With the appointment, he was promoted to the acting rank of commodore and, in July 1951, he was confirmed in that rank.

Vice-Admiral Rayner took command of the aircraft carrier HMCS *Magnificent* on March 11, 1953. Under his command the carrier was the largest unit of the RCN to participate in the Coronation Naval Review, at Spithead, in June of that year.

He was appointed naval assistant to the Chief of the Naval Staff at headquarters in January 1955 and on May 27, 1955, he took up the appointment as Chief of Naval Personnel with the rank of rear-admiral. He was appointed Flag Officer Pacific Coast, with headquarters at Esquimalt on Aug. 14, 1957.

Vice-Admiral Rayner was promoted to his present rank and became Chief of the Naval Staff on Aug. 1, 1960.

His appointment ended on July 20, 1964, and a week later he proceeded on retirement leave.

Vice-Admiral and Mrs. Rayner have six children. The family resides at 187 Clemow Ave., Ottawa.

THERE WAS MORE than ordinary significance to the farewell engagements and visits of Vice-Admiral Rayner, the Royal Canadian Navy's last Chief of the Naval Staff. Not only was the spirit of these occasions suffused with the high regard for the honoured departing guest, his own words and attitude bespoke the affection which he held for the service, its officers, men and women, and the civilian personnel. There was also nostalgic recognition that an era had ended—not that the glory had departed but that in the future it would be shared by others of worthy but unaccustomed traditions.

The Royal Navy has itself been subjected in recent months to a degree of integration at the top and its senior officers considered it fitting that they should honour Admiral Rayner at an Admiralty Board dinner in London on June 1.

Three days later, Admiral Rayner was tendered a farewell reception by the Naval Member, Canadian Joint Staff, London, and his officers.

On June 23, he was guest at a farewell dinner given by the Chief of the General Staff and the Members of the Army Council, Ottawa.

The officers who served under him at Naval Headquarters were his hosts

at a farewell mess dinner at HMCS Carleton, the Ottawa naval division, on July 2.

Admiral Rayner paid a farewell visit to the Pacific Command from July 8 to 12, during which he was a guest at a mess dinner given by seagoing officers, at a Command reception and at a dinner, given by the Lieutenant-Governor of British Columbia, General George R. Pearkes, VC, former Minister of National Defence.

His last visit to the Atlantic Command was made on July 14 and 15, at which time he was dined by the Flag Officer Atlantic Coast and the officers of the Atlantic Command.

From his visits to the Atlantic and Pacific Commands, Admiral Rayner takes with him two similar souvenirs, each one a silver tray adorned with the badges of the ships serving on the respective coasts.

In a farewell message to the Fleet, on July 20, Admiral Rayner said;

"Today I hand over the appointment of Chief of the Naval Staff to Rear-Admiral K. L. Dyer. I have visited as many commands as I could fit in during a busy schedule to say a personal farewell. This message is addressed to everyone connected with the Navy and especially to many to whom I have been unable to say goodbye.

"We are coming to the end of an era and soon the new integrated organization will be put into effect at National Defence Headquarters. While the appointment of Chief of the Naval Staff will lapse, I am convinced that the Navy will continue to progress. It is built on solid foundations. We have good men in good ships. My visits to the commands have confirmed my belief that we are members of a great service. This has been largely achieved through a very strong driving desire by many personnel to excel at whatever they undertake, whether it be in the operational or technical fields or, indeed, in community enterprises.

"I would like to express my heartfelt appreciation and thanks to both uniformed and civilian naval personnel for your loyal support and dedicated efforts to maintain an efficient and progressive Navy. It is my earnest hope and expectation that you will continue to give the same devoted service to the Navy when it is integrated so that our country will continue to have the strong Navy that it needs.

"Goodbye and God bless you all."

DURING the 11-day interval between Vice-Admiral Rayner stepping down and the formation of the new headquarters organization Rear-

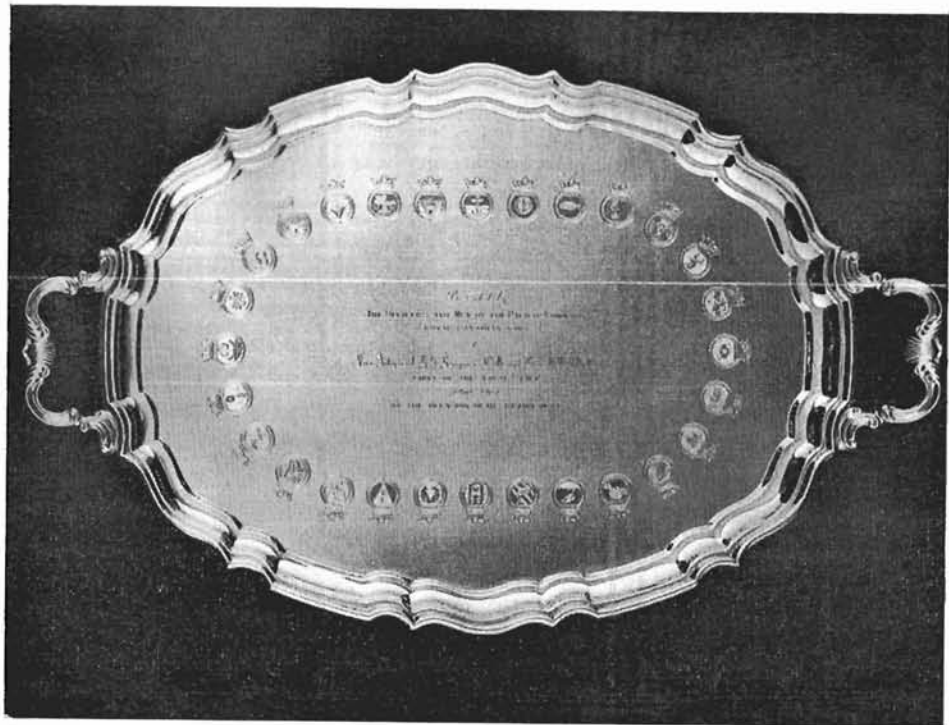

Personnel of the Atlantic and Pacific Commands presented similar silver trays, each adorned with the badges of ships serving in the respective commands, to Vice-Admiral H. S. Rayner as farewell mementoes. Shown is the tray presented by the Pacific Command during his farewell visit here. (E-77410)

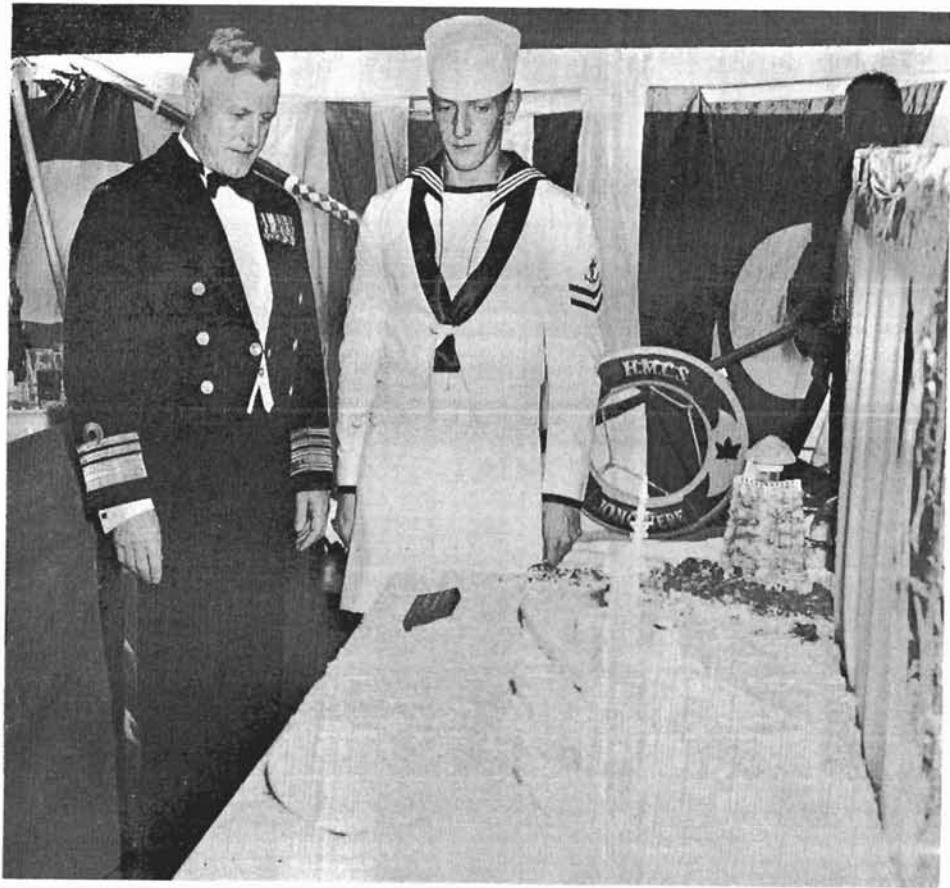

During his farewell visit to the Pacific Command, Vice-Admiral Rayner was the guest of commanding officers of the Fourth Escort Squadron on board the Beacon Hill. For the occasion, Ldg. Sea. Allan E. Penny, a cook in the ocean escort, baked a special cake, which Admiral Rayner is seen admiring. The cake was later presented to the children of the Queen Alexandra Solarium. (E-77450)



VICE-ADMIRAL K. L. DYER

Admiral K. L. Dyer was Acting Chief of the Naval Staff, a post he vacated on assuming the appointment of Chief of Personnel, in the rank of vice-admiral, on August 1.

In a general message on July 23, Admiral Dyer said:

"On assuming my new appointment, I wish to assure all officers, men and women of the Royal Canadian Navy and Royal Canadian Naval Reserve,

along with the civilian managers and employees serving with the Navy, of my continuing interest in their behalf. Having spent most of my life in the Navy, I know and share the pride that you have in your service and appreciate the sacrifices that you have made for our country.

"As Acting CNS my appointment will be a temporary one. The three service headquarters are in a transitional stage. After the new legislation enacting a single Chief of Defence Staff in place of the existing Chief of Staff has been proclaimed, our loyalty, dedication and respect will naturally and willingly be given to the new Chief of Defence Staff, Air Chief Marshal F. R. Miller, to help him in his heavy and responsible duties.

"At that time, I will become the Chief of Personnel and Principal Naval Adviser to the Defence Staff. This latter function has been approved by the Minister as additional assurance that adequate representation in naval matters will be available to Defence Staff and Defence Council.

"It is an important principle of the new organization that an acceptable level of specialized service be maintained in the integrated Canadian Forces Headquarters. In addition, in appointing integrated staff, the need is recognized that an adequate and fair distribution be made from within the three services.

"To a great degree it will be necessary to place immediate reliance on the naval elements of the headquarters staff to maintain touch with maritime developments while carrying out my overall personal responsibilities. However, I hope it will be possible, as Chief of Personnel, to visit the Fleet and shore establishments personally and maintain contact this way as well.

"It is realized that there are many unanswered questions in individual minds regarding the implications of the new policy. As implementation proceeds from the currently developing plans, it is intended that as wide a circulation of information as possible be made.

"There may be interim difficulties and unexpected situations to be faced in setting up the new organization. While these should have a minimal effect on the Fleet, we must be ready to meet them and be prepared to learn new ways. At the same time, I know our comrades-in-arms will benefit from our experiences in operating efficient and economical forces.

"Given the whole-hearted co-operation of all individuals, the problems will be overcome and the aim achieved of providing Canada with a defence organization suited to its needs. I have the utmost confidence that all of us in the Navy will give this support for the good of the service and our country."

INTEGRATION

ON AUGUST 1, 1964, a new era began for the Royal Canadian Navy, the Canadian Army and the Royal Canadian Air Force.

On that day Naval Headquarters, Army Headquarters and RCAF Headquarters ceased to exist, the posts of the various Chiefs of Staff were vacated and command became centred in one Chief of Defence Staff and one Canadian Forces' Headquarters.

Under the CDS and the Vice-Chief of Defence Staff (VCDS), the headquarters organization includes a Defence Staff Secretariat, a Planning Staff and the four following functional branches:

Secretary Defence Staff: Responsible to the CDS for the co-ordination and dissemination of orders, instructions and information and the general handling and conduct of correspondence and messages;

Assistant Chief of Defence Staff (ACDS): Responsible to the VCDS for plans, intelligence, programs and systems analysis;

Chief of Operational Readiness (COR): Responsible for operations, operational training, readiness of forces, operational requirements, army militia, flight safety;

Chief of Personnel (CP): Responsible for manning, officers' and men's careers, individual training, security, personnel services, including chaplains, medical, dental, welfare and policy for pay and allowances;

Chief of Logistics, Engineering and Development (CLE): Responsible for development, material procurement, supply management, material maintenance, transportation and movements, engineering policy and programs, systems and sub-systems engineering;

Comptroller General (CG): Responsible for budget and program financial management, accounting services, including military pay, general organization and establishments and management engineering services.

The evolution from single-service directorates to integrated divisions and directorates will in most cases be gradual, the rate of change varying between branches, depending on the size and complexity of functions. In the meantime, while continuing as single service entities, directorates will be responsible to a higher integrated staff level.

Following are the appointments of senior personnel in the new integrated Defence Staff, as announced by Hon. Paul Hellyer, Minister of National Defence:

Chief of Defence Staff: Air Chief Marshal Frank Miller, 56, former Chairman, Chiefs of Staff Committee.

Vice-Chief of Defence Staff: Lieutenant-General Geoffrey Walsh, 54, former Chief of the General Staff.

Chief of Operational Readiness: Lieutenant-General Jean Victor Allard, 51, former Major-General Survival.

Chief of Personnel: Vice-Admiral Kenneth Dyer, 48, former Vice-Chief of the Naval Staff.

Chief of Logistics and Engineering: Air-Marshal Clare Annis, 52, former Vice-Chief of Air Staff.

Comptroller General: Lieutenant-General Robert Moncel, 47, former General Officer Commanding Eastern Command, Halifax.

Assistant Chief of Defence Staff: Air Vice-Marshal Wilfred Bean, 51, former Air Member for Technical Services.

Following are the names of Deputy Chiefs:

Deputy Chief of Operational Readiness: Rear-Admiral Robert P. Weland, 46, former Senior Naval Officer Afloat (Atlantic).

Deputy Chief of Personnel: Air Vice-Marshal Maxwell P. Martyn, 51, former Acting Air Member for Personnel.

Deputy Chief of Logistics and Engineering: Major-General George Lilley, 51, former Army Comptroller General.

Deputy Comptroller General: Rear-Admiral Charles J. Dillon, 52, former Naval Comptroller.

A second deputy position is authorized under the Chief of Logistics and Engineering but will not be filled until a later date. Meanwhile, the heads of the present Technical Services branches will carry on in their duties for a limited time, in order to keep the Services supply systems functioning during the transitional period when the three very different systems are being synchronized as the first essential step toward their integration into a single, automated system.

BIOGRAPHIES

Air Chief Marshal Frank R. Miller, CBE, CD

Chief of Defence Staff

AIR CHIEF MARSHAL Miller was born on April 30, 1908, at Kamloops, B.C., and graduated from the University of Alberta with the degree of BSc in Civil Engineering. He joined the RCAF in 1931 and served in various flying, training and administrative capacities until the outbreak of the Second World War.



AIR CHIEF MARSHAL
FRANK R. MILLER

During the war, Air Chief Marshal Miller served in numerous senior positions in Canada, commanding special training schools, including the Air Navigation Schools at Rivers, Man., and Penfield Ridge, N.B. and the General Reconnaissance School at Summerside, P.E.I. He also served at Air Force Headquarters as Director of Training Plans and Requirements and as Director of Training.

He proceeded overseas in 1944 and served with the Canadian Bomber Group in the capacity of Station Commander and later as Base Commander. In the spring of 1945 he was selected to fill a senior appointment in the "Tiger Force" in preparation for operations against Japan. After his return to Canada in 1945, Air Chief Marshal Miller was posted to Air Matériel Command as Chief Staff Officer and later became the Air Officer Commanding. He attended the United States National War College from August 1948 until September 1949, at which time he assumed the appointment of Air Member Operations and Training at AFHQ.

In August 1951 he was appointed Vice-Chief of the Air Staff. In addition to the heavy responsibility he carried in this position, he made an outstanding contribution in the field of Canada-U.S.A. military relations as the Canadian air representative on the Canada-U.S.A. Permanent Joint Board on Defence.

In August 1954 Air Chief Marshal Miller was appointed to the position of Vice-Air Deputy at SHAPE Headquarters, Paris. He was appointed Deputy Minister of the Department of National Defence on August 15, 1955.

In April 1960 he was appointed Chairman, Chiefs of Staff, with the rank of Air Chief Marshal.

He became Chief of Defence Staff on August 1, 1964.

In January 1946 the Air Chief Marshal was appointed a Commander of the Most Excellent Order of the British Empire for distinguished service and was also mentioned-in-despatches in 1945 while serving overseas.

Vice-Admiral Kenneth Lloyd Dyer, DSC, CD, RCN

Chief of Personnel

VICE-ADMIRAL Kenneth Lloyd Dyer was born in Toungoo, Burma, on October 7, 1915. He came to Canada in 1928, attended King's Collegiate School, Windsor, N.S., and the University of King's College, Halifax, and in 1933 entered the Royal Canadian Navy as a cadet. His early training was with the Royal Navy.

In 1934-35, he served as a midshipman in the battle cruiser HMS Hood, and later, in the British cruiser *Enterprise*.

After courses ashore in Britain, Vice-Admiral Dyer was appointed to the sail training vessel HMCS *Venture* and then the destroyer *Saguenay* in 1938. He left the ship in April 1940 to take an advanced gunnery course at the Royal Naval Gunnery School, Portsmouth.

His course was interrupted a month later when he, like most other available officers and men, was called upon to take part in the evacuation of France, both at Dunkirk and St. Valery.

Returning to Canada in 1941, Vice-Admiral Dyer was gunnery officer of HMCS *Stadacona* until May 1942 when he was appointed in command of the destroyer *Skeena*. Two months later, his ship shared a U-boat kill with the corvette *Wetaskiwin* after a four-hour hunt. Rear-Admiral Dyer was awarded the Distinguished Service Cross for his part in the action.

In April 1944 he took command of the destroyer *Kootenay* and early the following year was appointed Training Commander at HMCS *Somers Isles*, the RCN sea training base, Bermuda.

Following the war, Vice-Admiral Dyer served for two years as executive officer of the aircraft carrier *Warrior* and in 1948-49 took staff courses in Britain, followed by an appointment to Naval Headquarters, Ottawa, as Deputy Chief of Naval Personnel.

In October 1951 he became commanding officer of the aircraft carrier *Magnificent* and in April 1953 was ap-

pointed in command of the RCN Barracks at Esquimalt and promoted to the rank of Commodore.

Vice-Admiral Dyer became Assistant Chief of Naval Staff (Warfare) in September 1954 and in 1956-57 attended the National Defence College, Kingston. In July 1957 he was appointed to Naval Headquarters as Chief of Naval Personnel and promoted to his present rank.

Vice-Admiral Dyer was appointed Flag Officer Atlantic Coast, Maritime Commander Atlantic and Commander Canadian Atlantic Sub-Area of NATO in August, 1960.

He became Vice-Chief of the Naval Staff at Naval Headquarters, Ottawa, on July 11, 1963.

On August 1, 1964, he became Chief of Personnel in the integrated headquarters staff and was promoted to his present rank.

Rear-Admiral Robert Philip Welland, DSC and BAR, CD

Deputy Chief of Operational Readiness

REAR-ADMIRAL Robert P. Welland was born March 7, 1918, and entered the Royal Canadian Navy as a cadet in August 1936 from McCreary, Manitoba. He now makes his home in Ottawa.

After training with the Royal Navy, he returned to Canada early in 1940 and was appointed to the River class destroyer *St. Laurent*. Later that year the *St. Laurent* sank a German U-boat off the coast of Scotland and Rear-Admiral Welland was awarded the Dis-



REAR-ADMIRAL R. P. WELLAND

tinguished Service Cross for "courage and enterprise in action."

In 1941 he took anti-submarine specialist training in Britain, and later became staff officer (anti-submarine) to the Commanding Officer Pacific Coast. In January 1943 he was appointed executive officer of the destroyer *Assiniboine* and in October of that year became commanding officer of the ship. In December 1944 he took command of the Tribal class destroyer *Haida* and commanded that ship until the end of the war.

During the Korean hostilities Rear-Admiral Welland commanded the destroyer *Athabaskan*, a unit of the first Canadian naval contingent to the United Nations force. During this command he was awarded a Bar to his DSC for "courage and initiative" in the Korean theatre. He was also mentioned in despatches and awarded the United States Government Legion of Merit, Degree of Officer, for his services during this period.

In 1953 Rear-Admiral Welland commanded the naval component of the Canadian Armed Forces contingent that attended the Coronation of Her Majesty, Queen Elizabeth II.

He later served at Naval Headquarters as Director of Naval Training and in August 1954 he became commanding officer of HMCS *Venture*, junior officer training establishment at Esquimalt.

Rear-Admiral Welland took command of the cruiser *Ontario* in August 1956 and a year later was appointed in command of HMCS *Shearwater*, naval air station.

In July 1961 he was appointed Assistant Chief of the Naval Staff (Air and Warfare), at Naval Headquarters.

Rear-Admiral Welland became Senior Canadian Officer afloat Atlantic in October 1962.

On June 17, 1964, he became acting Vice-Chief of the Naval Staff at Naval Headquarters. His appointment as Deputy Chief of Operational Readiness and his promotion to his present rank were effective on August 1, 1964, with the formation of the integrated Canadian Forces Headquarters.

Rear-Admiral Charles Joseph Dillon, CD

The Deputy Comptroller General

REAR-ADMIRAL Charles Joseph Dillon was born in Montreal on April 27, 1912, and entered the former RCNVR as a cadet in 1931. For the next seven years he served in naval ships and establishments on both coasts and



REAR-ADMIRAL C. J. DILLON

in 1938 was on board the schooner, HMCS *Venture*, during her first training cruise to the West Indies.

At the outbreak of the Second World Rear-Admiral Dillon went on active service. He held pay and secretarial appointments ashore and served as supply officer in the auxiliary cruiser *Prince Henry* and the Canadian-manned escort aircraft carrier HMS *Nabob*.

He transferred to the RCN in 1944, while serving in HMCS *Avalon*, RCN establishment at St. John's, Newfoundland.

In November 1945 he was appointed to Naval Headquarters and two years later he became Naval Secretary. In July 1950 he assumed the duties of Command Supply Officer, Pacific Coast, and in September 1952 was appointed Command Supply Officer, Atlantic Coast.

He returned to Naval Headquarters in August 1954 as Deputy Supply Officer-in-Chief and in August 1955 became Supply Officer-in-Chief of the RCN.

Rear-Admiral Dillon attended the Imperial Defence College, London, England, prior to taking up the appointments of Senior Naval Officer, St. Lawrence River Area and Naval Officer-in-Charge, Montreal, in January 1962.

He was appointed Naval Comptroller and a member of the Naval Board in July 1962.

His new appointment as Deputy Comptroller General in the integrated Armed Forces staff was effective August 1, 1964.

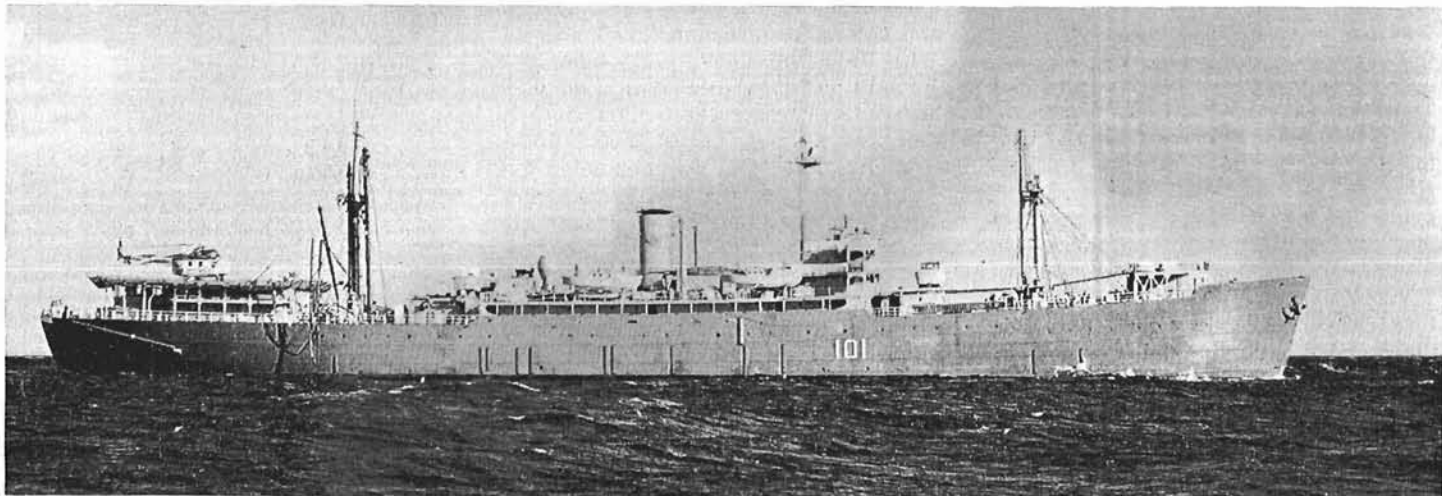

HMCS Cape Scott will provide transport for the scientists of a half-dozen Canadian universities to Easter Island on a fact-finding medical mission. Although Easter Island is 4,460 nautical miles due south of Piapot, near Saskatchewan's western border, the facts of geography make Halifax closer to the lonely Island than is Esquimalt. (HS-59754)

EASTER ISLAND EXPEDITION

THE DEPARTMENT of National Defence will co-operate with six Canadian universities and other scientists on a fact-finding medical mission to Easter Island being undertaken with the consent and co-operation of the government of Chile, it was announced by Hon. Paul Hellyer, Minister of National Defence.

The repair ship HMCS *Cape Scott*, based at Halifax, will take an expedition of medical scientists to Easter Island in December 1964. The Easter Island Expedition Society will obtain data on the distribution of disease and hereditary factors in the isolated population of the South Pacific island.

Sponsored initially by the World Health Organization, the expedition forms part of the Human Adaptability Project of the International Biological Program.

The *Cape Scott*, commanded by Cdr. C. A. (Tony) Law, will sail from Halifax Nov. 16, reaching Easter Island Dec. 14. After a nine-day stay there she will proceed on a southeastern Pacific cruise until her return to Easter Island Feb. 11 to embark the expedition. She ship will sail in mid-February for Halifax where she is due to arrive March 17.

The expedition is being undertaken by staff members of six Canadian universities, with the participation of scientists from Chilean, British, United States and Scandinavian medical schools. Canadian universities are McGill University, Montreal; the University of Montreal; Dalhousie University, Halifax; University of Toronto; Uni-

versity of Manitoba, Winnipeg, and University of British Columbia, Vancouver.

Approximately 25 scientists will participate under the general supervision of Professor Stanley C. Skoryna, director of the Gastro-Intestinal Research Laboratory and associate professor at McGill. Dr. H. Roche Robertson, Principal and Vice-Chancellor of McGill, is president of the Easter Island Expedition Society. Never before has such a medical survey been undertaken by Canada on such a large scale. It will take about two months.

Four medical teams will examine the population composed of 1,200 individuals and collect biological specimens. In addition, several scientists will be in charge of specialized studies in the fields of epidemiology, bacteriology, genetics, hematology, sociology and anthropology.

Surgeon Captain Richard Roberts, RCN, Chief of Medicine, Canadian Forces Hospital, Halifax, will be in charge of medical examinations. His wife, Professor Maureen Roberts, of Dalhousie University, will supervise genetic studies.

Easter Island is located at 27° 20' S; 109° 20' W in the South Pacific, about 2,200 miles from the coast of South America. Its only regular contact with the mainland is the annual visit of a supply ship from Chile. Pitcairn Island, 1,100 miles to the west, is the nearest inhabited land. The Canadian expedition will voyage some 5,000 miles to Easter Island from Halifax, bringing with it in HMCS *Cape Scott* a "portable"

medical laboratory. Halifax is the nearest Canadian port.

Some scientists claim that the population arrived from the Polynesian islands. Others, notably the Norwegian Thor Heyerdahl, of "Kon-Tiki" fame, proposed the theory that at least part of the inhabitants came from South America.

A strange and fascinating culture arose on Easter Island and much mystery surrounds to long-faced, long-eared statues, often surmounted by tall cylindrical hats, found there. The statues, associated with burial platforms, are often as high as a two-storey building.

The island was discovered for the western world by the Dutch admiral, Jacob Roggeveen, on Easter Day, 1772. Notable explorers who visited there were Captain James Cook in 1774 and La Perouse of France in 1786. The population has numbered perhaps as many as 4,000 but was decimated by tribal warfare, slave traders, and introduced diseases. There were only 172 people when, in 1888, Chile officially took possession. The island is administered by the Chilean navy.

HMCS *Cape Scott*, the sea transport, is an 11,270-ton repair ship built for the Royal Navy at Vancouver in 1944. As HMS *Beachy Head*, she served as an escort maintenance vessel in the Far East and later as HMS *Vulcaan* of the Royal Netherlands Navy. Returned by Britain to Canada in 1952, she was commissioned HMCS *Cape Scott* in 1959 at Halifax for employment in support of the RCN Atlantic fleet.



THE CYCLIC SYSTEM

UNTIL 1957 RCN trades were composed of separate user and maintainer specialists. Following the report of the Ad Hoc Committee on RCN Personnel Structure (Tisdall Committee) the user-maintainer concept was applied to many trades. The period of implementation was not without headaches. Many tradesman of the old categories were not fully adaptable to conversion to the new structure. These men, however, continue to be of great value to the Navy, because the functions at which they are adept are still necessary.

In early 1964 a RCN Personnel Structure Review Team, chaired by Rear-Admiral W. M. Landymore, was formed to examine the progress of the Navy towards its new structure, including an assessment of the user-maintainer concept. The review team, in its deliberations, assessed the state of user-maintainer efficiency as indicated by tradesmen developed *entirely by the new system* rather than by studying the problems of user-maintainer tradesmen converted from the former user and maintainer trades. The review team recommendations in this respect are designed to accelerate the development of fully trained tradesmen in the Navy.

Many persons have asked about the timing of the review team's investigations *vis-à-vis* the current movement towards integration of the three services. The answer is that the Defence Force will still require to operate ships, the ships will need tradesmen to operate and maintain their equipment and watchkeeping officers will remain essential. There can be no better time for the Navy to have a look at itself in order to provide the new Chief of Defence Staff with a naval arm which will stand up to his requirements in the near and more distant future.

Broadly, the finding of the review team, as reported to the Naval Board,

was that structure introduced as a result of the Tisdall Committee recommendations was sound. An opportunity was given to all persons in the Navy to submit briefs or criticisms and, if they desired, to appear before the review team to amplify a written brief. In addition, the review team summoned various responsible authorities to gain the benefit of their thoughts on all aspects of the Navy. In all, 215 briefs were submitted to the team, and a total of 102 officers and men appeared before it. Witnesses ranged from rear-admiral to able seaman.

The review team's look was to the future. The present and past were used only as a guide. It was established that the officers and tradesmen produced by the current RCN personnel structure would be adequate to maintain our vessels in the years to come.

Specifically, commanding officers were highly complimentary with regard to the product of the ROTP entry officer-career plan. The most senior of this category were, by early 1964, lieutenants employed in their second sea phase. Again, specifically, the highest praise was heard for the standard-trained product of the seaman user-maintainer concept. The senior of these, in early 1964, were newly qualified trade group 3 tradesmen, who have only recently been drafted to sea.

Many criticisms were heard concerning the efficiency of components of the Navy or of the Navy as a whole. Many of these were valid but not to the point. A large number of the criticisms directed toward the structure which the review team was examining were, on analysis, not criticisms of the structure at all but could be directly related to shortages of personnel and instability in ships' companies. A second look at the spectrum of criticisms will show that, if the Navy could greatly increase stability and aim at reducing personnel

shortages, large benefits in efficiency could result. Shortages of personnel include shortages of *trained* personnel.

In fact, the gravest situation facing the RCN today is one of personnel training. It has been very hard to spare personnel for training without adversely affecting the Navy's ability to meet its commitments. Towards this end the review team made several major recommendations:

- That the men's initial engagement be increased from 3 to 5 years;
- that a four- to six-week basic trade indoctrination course should be introduced before the commencement of "on-the-job" training;
- that all men should be trained to group 2;
- that trade group 3 tradesmen be considered the "centre of gravity" of the user-maintainer structure;
- that a new principle of ship employment, to be known as "The Cyclic System", be introduced.

It is quite apparent that the five-year engagement would have been introduced, even without deliberation of the Personnel Structure Review Team. Experience with the three-year engagement has shown that the base of recruits, from which our tradesmen are trained, is not broad enough. In addition, the effective time of men in their first engagement has not been sufficiently rewarding to the service. Mathematically our re-engagement rate is sufficient to maintain a stable Navy, if the initial period is five years, but not if it is only three years.

As we are now carrying numbers of men who contracted for a three-year engagement and who will be followed by recruits who engage for five years, it is most desirable, from the Navy's point of view, to have numbers of the three-year men extend their initial engagement by two years. With plans to be put into effect the review team con-

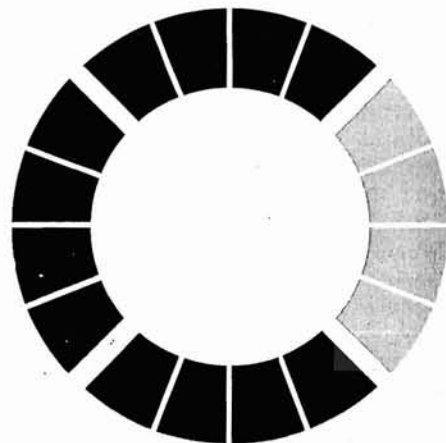

siders that, in relation to opportunities in civilian life, this opportunity should appear attractive to good men. It is quite usual for a man at the end of his first three years to be an able seaman, trade group 1. It will be quite usual for a man at the end of five years to be a leading seaman, trade group 2. The difference in pay between these two stations brings the seaman to a wage which is quite favourable in comparison with his expectations in civilian life. Some men could do better on "civvy street" but statistics show that a lot of men do much worse.

If the initial engagement is for five years, it is feasible to train *all* men to trade group 2. This is good for the men and good for the Navy. It simply was not practical under the three-year initial engagement.

Trade Indoctrination

THE TISDALL REPORT recommended that *wherever feasible* early training should be "on-the-job". In implementation, a heavy accent was placed on doing without formal training. The review team has recommended that the principle be altered to have a four-to-six-week trade indoctrination course for most trades, to be inserted between new entry training at *Cornwallis* and the man's first sea draft. In making this recommendation the review team did not intend to do away with the longer trade courses which have been established for new entry communications and air trades.

Under the concept of making trade group 3 the "centre of gravity" groups 1 and 2 are merely stepping stones on the route to trade group 3. The trade group 2 product is visualized as a proficient operator but, in the maintenance field, is intended to be a preventive maintainer and an assistant to the trade group 3 and 4 tradesman. His full development into proficiency in maintenance awaits his qualification to trade group 3. The trade group 3 man, then, is visualized as a user-maintainer *in fact*, in the area of the equipment with which he is associated. There will be no place in the RCN of the 1970s for men who are not completely adept at their specialties.

With some regret, the review team recommended the phasing out of what has been a valuable profession in our service. It is, in fact, a phasing out of a name only. The review team recommended that the electronic technician (LT) trade be displaced by tradesmen of the various allied trades. If they desire, LTs will be permitted to transfer

to other trades. If they wish to remain LTs, they will be permitted to do so and will proceed via a career as if the LT trade were remaining at full complement. In other words, as senior LTs proceed to retirement their places will be filled by promotion of juniors. When the last man in such a chain of promotions vacates a complement position, this complement position will be allocated to one of the user-maintainer trades of the so-called "electrical trades". The remaining LTs will be used to off-set tradesmen who have been converted from former user trades, and whose best employment until they retire is frequently on the operational side of the house.

The electronic technician, by various names, has been a valued contributor to the efficiency of our ships since early in the Second World War. The review team recognized his value, but his position on board ship is often somewhat of an anomaly. His divisional officer is frequently the engineering officer but his major employer may be the weapons officer or the operations officer—frequently partly both. He has been expected to delve deeply into a wide variety of equipment while at the same time specifications for tradesmen of other trades called for deeper training in a narrower variety of equipment. His employment on board, as could be expected, frequently screened other tradesmen away from assuming their proper position and responsibility for maintenance of their own equipment. In addition, the maintenance of the LT structure has recently been affected by the diversion of promising candidates from other trades.

The Cyclic System

THE RCN CYCLIC SYSTEM of employment of the fleet has been developed to provide, amongst other things, predictable opportunities for early training through the lower trade groups. At the same time, the employment of the tradesman has been stabilized so that he can anticipate suitable long periods of employment—without drafts from job to job—to prove out his training and to develop the necessary qualities to prepare him for further training.

To understand the principles of the RCN Cyclic System for employment of one ship or squadron, refer to Figure 1.

One cycle is 16 months' duration, divided among four phases. Phase I is an alongside period for ship maintenance and personnel training.

On completion of Phase I the ship proceeds to sea in Phase II for workups, squadron exercises and probably a cruise. This is a phase of increasing ship efficiency.

Phase III, the Fleet Phase, represents the highest state of operational readiness of HMC Ships. Ships in this phase will be the first to be called up to meet an emergency.

Phase IV, designated "Personnel Assistance Phase", is a period of gradual running down of the ship's operational availability. In this phase some men will be withdrawn early for courses which are too long to be accommodated in the four months of the approaching Phase I. Ship employment will include cadet training, showing the flag at local festivities and certain trial projects.

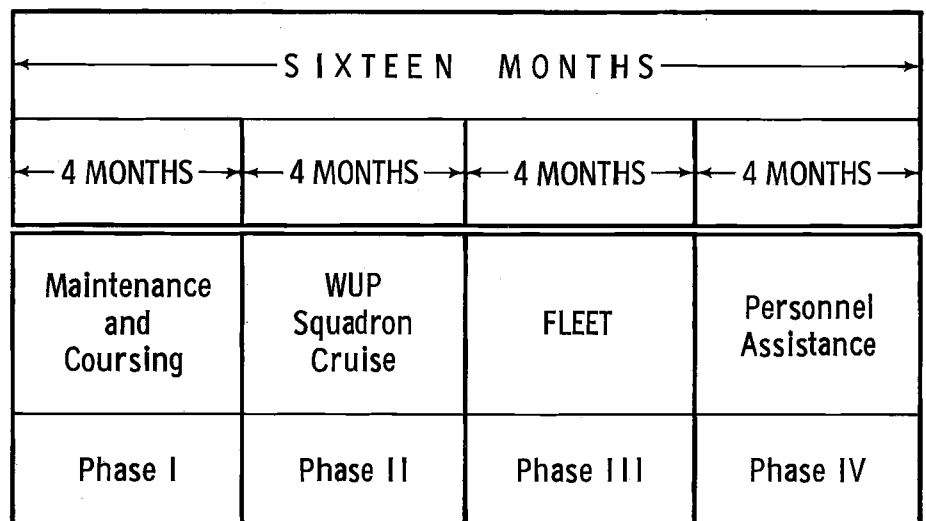

Figure One

EMPLOYMENT OF MEN IN FIRST 5-YEAR ENGAGEMENT UNDER CYCLIC SYSTEM

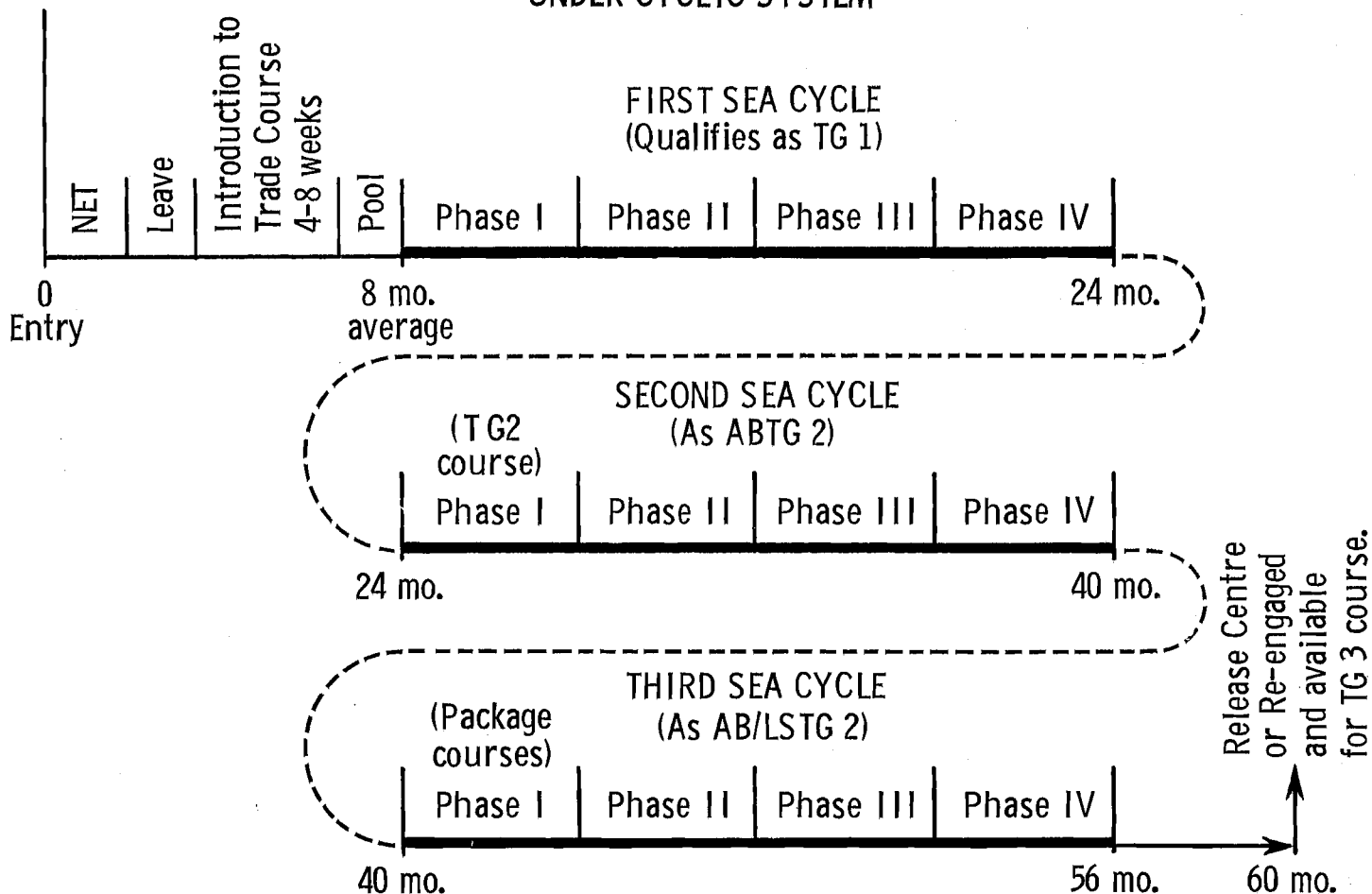

Figure Two

Ships in other squadrons follow identical cycles, but the cycles are so distributed that, at any given time, there is a squadron carrying out each phase listed. Should an emergency arise, of a nature greater than can be handled by ships in the Fleet Phase, these ships will be augmented by ships from Phase II or Phase IV or, if sufficiently severe, from both. The operational commander will thus be able to count on immediate availability of one quarter of his ships in the highest state of efficiency, and another half able rapidly to reach a similar state.

The ship's commanding officer will be able to count on stability in his ship's company during the various operational phases of the cycle. Ships' companies will be so selected that no man will reach expiration of his normal engagement during the operational phases. No man need be drafted from the ship for courses, because a large proportion of the ship's company will be available for necessary courses, at the same time, during phase I.

Forecast of Seaman Employment

THE PATTERN of employment for seamen developed below is for a tradesman who has a high proportion of seetime in his first engagement. Employment will, of course, vary from trade to trade.

In his first five-year engagement, the typical seaman will follow the pattern of employment shown in Figure 2.

After new-entry training, and assignment to a trade for which he is suited, the typical new entry will be given a four-to-six week trade familiarization course. Upon completion he will be drafted together with trainees of similar engagement dates, to a squadron entering Phase I of the Cyclic System. During the first cycle he will receive on-the-job training with the object of achieving trade group 1 at some time before completing 24 months of service. Depending upon the length of the trade group 2 course in his trade, he may be withdrawn from his ship during Phase IV. If the trade group 2 course is 17

weeks or less he will be withdrawn when the ship enters the new cycle at Phase I. The word "withdrawn" is used to connote his attendance at courses in the Fleet School. He will not be *drafted* from his ship. He will remain a member of that ship's company.

Successful completion of the trade group 2 course will coincide with the start of the ship's operational phases in the seaman's second cycle. He should be advanced to trade group 2 during this cycle and will reach its completion with considerable experience in the peculiarities of his ship and her equipment.

Upon entering Phase I of the third cycle the tradesman should be a valuable assistant to the senior tradesman engaged in maintenance of the ship and her equipment during Phase I. During this phase the trade group 2 man should give an indication as to his future employability as a full-fledged user-maintainer. During a further 12 months of ship's operations, he will continue to be employed at the trade group 2 level

WORK PERIODS IN THE CYCLIC SYSTEM

WORK DEFINITION	LENGTH IN WEEKS	START TIME	SHIP'S STATE
PROTRACTED	34 or more	End Phase IV	Paid off
EXTENDED	17 to 34	As required in Phase IV	Manned
NORMAL	17 or less	Start Phase I	Manned
SHORT	3	Once per Phase	Manned

Figure Three

and may presumably reach the rank of leading seaman. At the end of his third ship-cycle he is approximately four months from the end of his five-year engagement and can go on to release. If he elects to re-engage he should have an excellent grounding for a trade group 3 course.

The tradesman, in engagements subsequent to the first, will follow, albeit more loosely, a cyclic system of employment similar to that in his first engagement. Periods of shore employment will be adapted to the same time cycle. Trade group 3 courses in many trades are frequently a great deal longer than can be accomplished in ships' Phases IV and I. Hence it will be necessary for tradesmen to be drafted to barracks to take these long courses. During sea employment at the higher trade group levels, opportunities will be provided in successive Phases I for tradesmen to undergo package courses; for example in equipments not covered in standard trade group courses.

Effect on Ships

AS STATED ABOVE, ships in the cyclic system will have predictable operational availability. Ships will continue to have periods of self-maintenance and dockyard maintenance. These have been redefined as "work periods" as shown in Figure 3.

The target program is for each ship of the fleet to have an extended work period every four cycles. Between these, there will occur three normal work periods and, during each of Phases II, III and IV, one short work period.

During Phase I, some instructors may be temporarily lent by the ship to the Fleet School to assist with basic trade training. In this maintenance and cours-

ing phase, the ship will lose all her TG1 personnel, but most TG4s, TG3s and TG2s (and OJTs) will be available for maintenance and husbandry.

Implementation

TO IMPLEMENT the cyclic system initially, all ships will be remanned with crews whose time of expiration, course requirements, promotion status, etc. are similar, and the ships will then be arranged into the phases which fit these crews. The change will take place during the period December 1964/January 1965, with the cyclic system commencing January 15, 1965.

The amount of work required to initiate the cyclic system in the time avail-

able is considerable. The Navy is sufficiently flexible to swing to a program of this nature but time restrictions are such that all authorities must fully understand their contribution to the altered program.

To ensure that each contributor understands the nature of his contribution and the necessary timing, a "Program Manager Cyclic System" has been appointed. He will be assisted by a full-time staff and his task will be:

- (1) to monitor progress of implementation,
- (2) to indoctrinate authorities concerned with implementation, and
- (3) to keep the men in the fleet informed of the impact of the system on them.

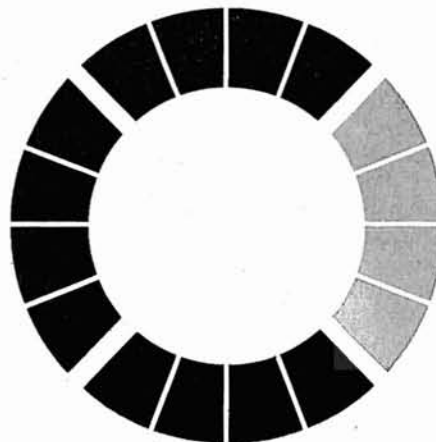

OFFICERS AND MEN

Engineer Officer Algonquin CO

Cdr. J. W. Mason has taken command of the destroyer escort HMCS *Algonquin* of the First Canadian Escort Squadron at Halifax.

Cdr. Mason was born in Winnipeg and entered the RCNVR in February 1943 as a stoker. He was demobilized in December 1945. In May 1949 having obtained a degree in mechanical engineering, he rejoined the navy as an acting sub-lieutenant and proceeded to Britain for engineering training.

Among his most recent appointments have been those of engineering officer on board the ocean escort HMCS *Buckingham*, the destroyer escorts *Ottawa* and *Chaudiere*, and naval liaison officer at the Naval Research Establishment, Dartmouth.

Cadets Exchanged With U.S. Navy

Two Regular Officer Training Plan cadets and one University Naval Training Division cadet were appointed to ships of the United States Navy for their 1964 summer training period at sea.

A similar number of midshipmen from the United States Naval Academy joined destroyer escorts of the RCN's Pacific Command for summer sea training.

Weddings

Lieutenant Edward Francis Abbott, *Stadacona*, to Julia Margaret McDiarmid, of Victoria.

Able Seaman Richard Baker, *Chaudiere*, to Eva May Sparks, of Westphal, N.S.

Sub-Lieutenant Robert Craig Brown, *Stadacona*, to Sandra Lois Edwards, of Collins Bay, Ont.

Sub-Lieutenant Kevin Burke, *Chaudiere*, to Beverly Anne Beaudin, of Cardinal, Ont.

Leading Seaman John Duxbury, *Chaudiere*, to Marie Etta Maillet, of St. Alphonse, Digby County, N.S.

Able Seaman Kenny Irving, *Chaudiere*, to Sharon Grant, of Halifax.

Sub-Lieutenant Eion Edward Lawder, *Margaree*, to Carol Dorothy Crombie, of Victoria.

Able Seaman Douglas L. Whitesell, *Gloucester*, to Anne Mathieson, of Copenhagen, Denmark.



Professor Mabel F. Timlin, of the University of Saskatchewan, Saskatoon, has a gyro repeater shown to her by CPO Frank G. Kramer. Professor Timlin was among members of the Royal Society of Canada given a cruise in HMCS *Fort Erie* around Charlottetown harbour. (HS-75263)

The Canadians are Officer Cadet Mart Leesti, Ottawa; Officer Cadet R. H. Ouellette, Comeau, Que., and Officer Cadet Antony E. Pitts, Bedford, N.S. Cadets Leesti and Ouellette have been studying at the Royal Military College of Canada, Kingston. Cadet Pitts is a student at Dalhousie University, Halifax.

They joined U.S. Navy ships for a summer training cruise to European and Mediterranean waters.

The RCN ships in which the United States naval midshipmen embarked were on training cruises to ports in California and Mexico.

RCs to Remain During Divisions

Naval General Message 118 sets an ecumenical tone in that Roman Catholic personnel will no longer be fallen out at divisions and was released with the approval of both Roman Catholic and Protestant Chaplains General of the Armed Forces. It reads in full:

"In future in HMC Ships and shore establishments when prayers are offered at divisions the Roman Catholics will not fall out but the Chaplain (P) will

offer prayers for the Protestants and the Chaplain (RC) will offer prayers for the Roman Catholics.

"No one has the authority to eliminate the prayers of either the one or the other. In the case of there being no Chaplain (RC) the senior Roman Catholic will offer prayers for the Roman Catholic personnel. The Roman Catholic prayers suggested as time allows are *The Lord's Prayer, Hail Mary, The Apostle's Creed, Act of Contrition, Act of Faith, Act of Hope, Act of Charity, Prayers to St. Brendan for Sailors, Prayer to St. Joseph, Prayer for Parents and Relatives* to be found in *Catholic Manual of Prayers* (Archbishop Roy) and *Sunday Missal*.

"It is emphasized that on Sundays and Holy Days of Obligation Roman Catholics are required to assist at Mass where the exigencies of the service permit. For Battle of the Atlantic Sunday and other special occasions regulations remain unchanged."

Lt.-Cdr. Irvine To Stettler

Lt.-Cdr. Thomas A. Irvine has been appointed in command of HMCS *Stettler*, Fourth Canadian Escort Squadron, based at Esquimalt. He is to take up his new appointment on August 24.

Lt.-Cdr. Irvine served in the Royal Navy during the Second World War and before entering the RCN in December 1952 was employed as a hydrographic surveyor.

In 1954, he served as hydrographer on board the former RCN Arctic Patrol Ship, HMCS *Labrador*, during her circumnavigation of North America via the Northwest Passage and the Panama Canal. He subsequently wrote and had published in book form an account of

Births

To Leading Seaman Peter J. Baine, *Chaudiere*, and Mrs. Baine, a son.

To Petty Officer William M. Comeau, *Chaudiere*, and Mrs. Comeau, a son.

To Lieutenant R. Giroux, *Montcalm*, and Mrs. Giroux, a son.

To Petty Officer A. J. Stringer, *Inuvik*, and Mrs. Stringer, a daughter.

To Petty Officer Philip J. Wylie, *Chaudiere*, and Mrs. Wylie, a son.

this cruise, entitled *The Ice Was All Between*. He has also served on board the ocean escort *Buckingham* as executive officer, and at *Stadacona*.

He has been at Naval Headquarters on the staff of the Director of Naval Operations as naval hydrographer since August 1962.

Captain Solomon Appointed JAF

Captain Allan O. Solmon until recently Naval Secretary, has been appointed Judge Advocate of the Fleet and Assistant Chief of Naval Personnel (Administration) at Canadian Forces Headquarters.

Captain Solomon succeeds Captain Philip R. Hurcomb who commenced retirement leave on August 4. Captain Hurcomb has been Judge Advocate of the Fleet since 1945, and Assistant Chief of Naval Personnel (Administration) since 1951.

Captain Solomon entered the former Royal Canadian Naval Volunteer Reserve in May 1942 and transferred to the regular force in February 1946. He holds degrees in Arts and Law from the University of Manitoba, and a degree in Public Administration from Carleton University, Ottawa.

Captain Hurcomb entered the former RCNVR in February 1942 and transferred to the regular force in January 1946. Educated at Lisgar Collegiate, Ottawa, and the University of Ottawa, he holds a degree in Law from Osgoode Hall, Toronto.

As Ottawa's 1931 tennis champion, and the youngest barrister at that time to be appointed trustee of the Carleton County Law Association, he is well known in the city's sports and professional circles.

After a preliminary training at Halifax, following his entry, Captain Hurcomb served as a legal specialist at Naval Headquarters and in 1945 was appointed Judge Advocate of the Fleet. In 1949, he was counsel to the Mainguy Commission which published its significant report on the RCN.

Naval Training Display Given

A dramatic display of naval training—on, over and under the sea—was presented by the Pacific Command of the RCN on July 6 in the Beacon Hill Park area of Victoria.

Designed to provide residents and tourists with a first-hand look at their navy at work, the naval display featured widely varied activities, including ships, divers and aircraft.



Rear-Admiral Jeffrey V. Brock, Flag Officer Atlantic Coast (right), presents a gunnery efficiency trophy to Captain D. L. MacKnight, Commander Fifth Escort Squadron, at a recent ceremony in HMC Dockyard. The trophy is competed for annually between the Second Escort Squadron on the Pacific Coast and the Fifth Escort Squadron based at Halifax. This is the second year the award has been won by the Fifth Squadron. Note the radar. (HS-75609)

Seven ocean escorts—units of the Command's Fourth Canadian Escort Squadron—presented a series of manoeuvres, staged a sail-past, then anchored and illuminated at nightfall. At midnight the ships sailed on the first leg of a five-week training cruise with nearly 200 Regular Officer Training Plan naval officer cadets embarked.

The fleet manoeuvres included a fly-past by aircraft from VU-33, the Navy's utility squadron at Patricia Bay.

During the afternoon naval divers moved from headquarters at Colwood and conducted a regular beach clearance and demolition training exercise in Horseshoe Bay on the park waterfront. The divers' show was directed by Lt.-Cdr. A. W. Rowse. Nearby, the RCN's mobile diving safety unit demonstrated and explained hazards which confront amateur divers. This unit, under the direction of Lt. John Rowland, over the previous several months, had visited 21 schools of lower Vancouver Island and warned nearly 10,000 students of the dangers of driving with improper equipment and lack of proper knowledge.

In the evening, in the Beacon Hill Park bandstand, the 48-member naval band of HMCS *Naden* presented a 90-minute concert. Under the direction of bandmaster Lt. Tudor Jones, the popu-

lar naval musicians offered a wide variety of selections, including a unique musical version of the RCN's sunset ceremony.

In charge of co-ordinating the entire program was Cdr. E. J. Semmens, officer-in-charge of the Operations and Weapons Division at *Naden*, and Chairman of the Command's ceremonial sub-committee.

"Such training and exercises are going on almost daily within the Command," he said "and the program set for July 6 was a consolidation of such activities to enable citizens of the area, and tourists, to see their navy at work."

He noted the ROTP cadets in the ocean escorts were partially responsible for the afternoon fleet manoeuvres, "under the watchful eyes of the ship's regular officers."

Lt.-Cdr. Muncaster Commands HU-21

Lt.-Cdr. Douglas Albert Muncaster has been appointed in command of Helicopter Utility Squadron 21, based at *Shearwater*.

He has been serving as senior pilot in Helicopter Anti-Submarine Squadron 50.

Lt.-Cdr. Muncaster joined the Royal Naval Volunteer Reserve in July 1945,

following wartime service with the RCAF. He transferred to the Royal Navy in December 1945, serving until December 1959. He joined the Royal Canadian Navy in August 1950.

Lt.-Cdr. Muncaster was awarded the George Medal for rescuing the pilot of a Sea Fury fighter aircraft which had crashed in flames near *Shearwater* in March 1955.

Moresby House New CPOs' Mess

The chief petty officers of the Pacific Command have found a new home for their mess at Moresby House on Esquimalt Road.

They were given permission to renovate the historic building, built at the turn of the century as the Coach and Horses Inn, at a cost of \$25,000.

Moresby House has previously served as an apartment house before the Navy took it over and turned it into headquarters for HMCS *Malahat*, Victoria's naval division.

It was used as Wrens' accommodation quarters.

The building's main floor has been redecorated to include a walnut panelled entrance which leads to the main lounge, a large room in which the original Coach and Horses fireplace has

been retained, and a dance floor and bandstand added.

Immediately adjacent are the dining room, which can seat 50 persons, and a panelled "stag" bar.

The second floor contains sleeping facilities for 15 persons, a TV room, plus space to establish two dormitories if more sleeping accommodation is needed.

Vice-Admiral Herbert S. Rayner, Chief of the Naval Staff, was presented with a life membership in the mess when he planted a dogwood tree in front of the building during his farewell visit to Pacific Command.

The Chiefs' mess was previously located on Lockley Road, behind the recreation building at HMC Dockyard.

Admiral Visits USN Air Station

A formal visit was paid by Rear-Admiral W. M. Landymore, Flag Officer Pacific Coast, on July 22 to Naval Air Station, Whidbey Island, Washington, returning the formal call at Esquimalt of Captain D. G. Gumz, Commander Fleet Air, Whidbey, in June.

For Admiral Landymore's visit, the crack NAS Whidbey Island drill team served as a guard of honour.

Accompanied by Captain Gumz, Admiral Landymore inspected the long-range anti-submarine planes of Whidbey's Patrol Squadrons One and Two. The planes frequently participate in joint exercises off the coasts of Washington, Oregon and British Columbia with similar planes of the RCAF's 407 Squadron, based at Comox, B.C., which come under Admiral Landymore as Maritime Commander, Pacific.

Bomb Found Under Bridge at Victoria

Possible tragedy was averted in late June when naval divers and demolition experts recovered a fully charged mortar bomb from a bank beneath the Gorge Bridge at Victoria.

The army-type projectile, three inches in diameter and about a foot and a half long, was first reported to Esquimalt police authorities, who in turn notified the Navy.

Lt.-Cdr. Earl Thompson and Lt. John Roland, both members of the Pacific Command's Diving Establishment at Colwood, hurried to the scene and recovered the dangerous explosive. The bomb was taken to Colwood for disposal.

It is believed the mortar bomb was discarded by some resident of the area who realized its potential danger.



Rear-Admiral Walter Hose, RCN (Ret), 88, of Windsor, first Chief of the Naval Staff of the RCN, (centre) chats with Rear-Admiral J. B. Caldwell, Chief of Naval Technical Services, and Liston B. McIlhagga, of Winnipeg, president of the Naval Officers Associations of Canada, at HMCS Carleton, the Ottawa naval division, at the associations' 19th annual meeting in June. Admiral Hose is honorary president of the NOAC. (O-15637)

Lt.-Cdr. Ward Palmer, officer in charge of the naval diving establishment, said the mortar was powerful enough to demolish an average house.

This explosive, he continued, might well have been found by some youngsters and not realizing the hazard, might have struck it with rocks, or thrown it about. It could have resulted in a grim tragedy. He said all suspected bombs or shells should be reported to police.

Fully qualified experts in the demolition field would then attend to the matter and dispose of the object safely and properly.

Gordon Mowatt Trophy Presented

Presentation of the Gordon Mowatt memorial trophy, awarded to the sub-lieutenant pilot at HMCS *Shearwater* who shows the most progress in improving his flying ability during the year, was made in June to Sub-Lt. Albert M. Bingley, of 880 Squadron, at ceremonial divisions at the naval air station.

The trophy, presented annually since 1960, was donated by Mr. and Mrs. Leslie G. Mowatt, of Montreal, in memory of their son who lost his life in the crash of a Tracker while taking off from the *Bonaventure* in December 1959.

A native of Pickering, Ont., Sub-Lt. Bingley has been flying from *Shearwater* and the *Bonaventure* as crew commander of a Tracker. He joined the Navy in 1957 as a naval cadet at HMCS *Venture*, Esquimalt. He is now living in Dartmouth and is married to the former Miss Lois Hoadley.

The presentation was made by Captain G. C. Edwards, commanding officer of *Shearwater*.

Four to Attend Defence College

Four senior naval officers have been appointed to the 1964-65 course at the National Defence College, Kingston, Ont.

They are:

Captain Victor Browne at present Chief of Staff to the Flag Officer Pacific Coast;

Captain John C. Chauvin, now Director of Fleet Maintenance, Naval Headquarters;

Captain John Edward Roue, Director of Operations Systems, Naval Headquarters, and

Cdr. Hubert G. Oliver, now Assistant Judge Advocate General, in Edmonton, for the Armed Forces in the Province of Alberta.

The staff course begins in September.



UNTD Cadets J. A. Leger and R. H. Warren and Cadet Captain T. D. Ling are shown plotting a course in the Navigation School at Cornwallis, during the University Naval Training Division's summer training. (DB-19054)

Officer to Serve On Nigerian Team

Lt.-Cdr. Kenneth R. Crombie has arrived in Lagos, Nigeria, to serve on the Canadian Armed Forces Training Team in that nation.

Lt.-Cdr. Crombie entered the RCN in Vancouver in July 1942 as a cadet. He took his early sea training on board ships of the Royal Navy and later served in Canadian motor torpedo boats, the former cruiser HMCS *Uganda*, and in various shore establishments.

Before his appointment to Nigeria, he was serving at *Stadacona*.

Pay Year Same As Fiscal Year

The pay year of the RCN regular force has been changed from the calendar year to correspond with the fiscal year of the Canadian Government.

As a result, the current pay year, which would normally end on Dec. 31, 1964, has been extended to March 31, 1965. Pay records will be closed thereafter on Sept. 30 and March 31 of each year.

Instructions concerning changes to be made in income tax deductions, assignments and payments will be promulgated.

Pay records for RCNR personnel will continue to be closed on June 30 and Dec. 31.

Cornwallis CO Goes to Norfolk

Captain Richard M. Steele has been appointed to the staff of the Supreme Allied Commander Atlantic, Norfolk, Virginia, as Assistant Chief of Staff, Personnel and Administration. Since August 1961, he has been in command of *Cornwallis*.

He succeeds Captain Dudley Gawn King, Okanagan Lake, B.C., who has proceeded on retirement leave. Captain King had held the NATO appointment in Norfolk since January 1959.

Captain Joseph Morrison Paul has taken command of *Cornwallis* and was promoted to his present rank on taking up the appointment.

Captain Paul was born in Edmonton and later moved to Mirror, near Red Deer, Alta. He entered the RCN as a boy seaman in 1934, and was promoted to warrant rank in 1941. He was executive officer of the destroyer *Haida* during her 1952-53 tour of operations in the Korean theatre; was made commanding officer of the frigate *Penetang* in 1954, and in 1955 became commanding officer of the frigate *Outremont*.

His most recent appointment was that of executive officer of the naval air station, *Shearwater*.

Naval Flyer Heads Warfare School

Cdr. Robert H. Falls has been appointed Director (RCN) of the Joint Maritime Warfare School, Halifax, and Officer-in-Charge Tactical Trainer.

He had been commanding officer of the destroyer escort HMCS *Chaudiere* since April 1963.

Cdr. Falls joined the RCAF in March 1942 and served with it until September 1945. He joined the naval reserve later that year and subsequently transferred to the regular force of the RCN.

He has served as commanding officer of fighter squadron VF 870; in the aircraft carrier *Bonaventure*, as Commander Air and at Naval Headquarters as Deputy Director Surface and Air Warfare.

Officers' Lists Have New Names

As a result of the recent personnel review, conducted by the team under Rear-Admiral W. M. Landymore, Flag Officer Pacific Coast, the names of the various lists within the officer personnel structure have been revised.

The object of the revision is to make the names more descriptive of duties performed by officers. Present regulations concerning promotion, employment and other matters for the Limited Duty List and the Special Duty List will apply under the new titles.

The General List designation has been changed simply to General; the Restricted Duty Section becomes General List—Specialist; the Limited Duty List now is General List—Branch, and the Special Duty List is the Specific Duty List.



The crowning glory of the Acropolis at Athens, the Parthenon was dedicated to the virgin goddess Athena 2,304 years ago. Sailors from the *St. Laurent* found that the passing centuries have failed to erase the temple's beauty and grandeur. (E-74896-279)

LONG WAY ROUND

Part Four

HMCS *ST. LAURENT'S* 14th port of call on her world cruise was Haifa, Israel, on April 23, 1964. Easily one of the most beautiful of all the ports we have yet visited, Haifa rises from the coast and extends up the historic slopes of Mount Carmel, with the new Don Carmel Hotel at the summit overlooking the city.

To the visitor, one of the first things to catch your attention is the thriving industry in both the port itself and the city. Later we were to discover for ourselves that this was a national characteristic upon which the nation is being built.

Met on arrival by several liaison officers of the Israeli Navy, we were afforded a welcome which we shall not soon forget. Excursions to the Sea of Galilee, Tiberias, Jerusalem and Tel

Aviv were made available without charge almost daily. Swimming in the Jordan River, water skiing on the Sea of Galilee or visiting a Kibbutz were all wonderful experiences in themselves. But few, indeed, did not look forward most of all to their visit to the holy city of Nazareth.

This town has changed little from the pictures painted of the biblical days of the Holy Family. Its narrow streets, red-tiled houses and tall cypress trees give it a timeless atmosphere. Its more than 25 churches, monasteries and convents mark many of the places associated with the life of Jesus.

Nazareth has always been a relatively poor town. In the days of Jesus many families had gouged out caves and had built their homes over them so that the central living quarters were cool in summer, warm in the winter.

Two such places designated by long tradition that we visited were the Church of the Annunciation, where the angel is supposed to have told Mary of the coming birth and the other, the Church of St. Joseph, where the Holy Family is thought to have lived, with the carpenter shop above the grotto living quarters.

Israel, so young and vigorous and so steeped in history, offered too much for everyone to see in such a short time and too much to recount in this brief narrative. However, the enthusiasm and hospitality of her people made our visit a wonderful and enlightening experience. The *St. Laurent* was the first Canadian warship ever to visit the State of Israel and it is hoped that the opportunity to visit comes again soon.

On April 27 we departed Israel for Istanbul, Turkey. On the morning of

April 30 we entered the Bosphorus, which separates the European and Asiatic section of Istanbul. This ancient city is the only one in the whole world astride two continents. The view as we passed the "Golden Horn" and anchored in front of the Dalmabahce palace was magnificent. Istanbul, with a population of over 2,000,000, is a city of nearly a thousand mosques. Although it is attempting desperately to be western, the city still retains much of the East. A visit to the immense "covered bazaar" is a proof of this. This ancient bazaar is a labyrinth and storehouse of carpets, brass, jewellery, furniture, and thousands of seemingly useless items, and, traditionally, one must haggle with great enthusiasm in order to arrive at a fair price.

For 30 members of the ship's company, a three-day bus tour of Ankara, the capital, was organized by the Canadian diplomatic and military staffs. Having had an opportunity to see a little of Istanbul, those journeying to Ankara were anxious to have a glimpse of Anatolia and the rural areas.

Frequently, as you make the eight-hour road trip from Istanbul to the capital, you think of Canada and the long rolling hills of southwestern Alberta. Although everywhere great agricultural industry is in evidence, the people dressed in gaily coloured clothes, till the soil as their ancestors did for many hundreds of years. Buffalo and mules pulling wooden ploughs are not a novelty and women, hoeing and planting in fields which literally reach beyond the horizon, can be seen from every rise. Probably quaintest of all sights are the hundreds of small villages, nestled at random across the expansive countryside, each with its own mosque and minaret rising majestically.

As you approach Ankara, in the distance you can see three cone-shaped hills upon which the city was originally founded. Ankara is not only, it seems, the capital of the Turkish republic but the symbol of the New Turkey. It has developed in two decades from an insignificant small provincial town into a city of more than 700,000 inhabitants. It is a modern metropolis with large boulevards, parks and squares and with many impressive features, such as the Hittite Museum and the Mausoleum of Kemal Ataturk, first president of the Turkish Republic.

We were all appreciative of the opportunity to visit Ankara and many rural communities in order to be better able to picture in our minds Turkey as it is today.

Our next port of call was Piraeus, Greece, and we arrived there on the

morning of May 7. Athens, the capital, is only a few miles away and what a delightful city it is! Broad, clean streets, white marble buildings and sidewalks, history unfolding at every street corner and the first real European atmosphere we had encountered since Malaysia.

Once again, thanks to the efforts of our untiring Chaplain A. J. Mowatt, many excellent tours were organized and without any doubt the time spent at the Acropolis was most fascinating. Many of us had seen pictures of the Acropolis with the stately Parthenon rising from it, but one cannot appreciate the beauty of this ruin until he sees it for himself.

Although time has been most unkind to these once unique edifices, the Par-

thenon truly is a wonder of the world. But there is more to the Acropolis than just a concentration of splendid ruins. There lies a memory, rising above the city, of a wonderful civilization which existed long ago and refused to die.

Although the Greeks hesitate to renovate these ruins for fear of doing an injustice, they have rebuilt the stadium. This stadium, in white marble, can hold 70,000 spectators and was built for the first modern Olympic games in 1896. It occupies the same site as the ancient Panathenaic Stadium, the building of which began in 330 BC and was completed in 140 AD by Herodus Atticus, the benefactor of the city of Athens.

A popular evening's entertainment was to attend the "Son et Lumiere"

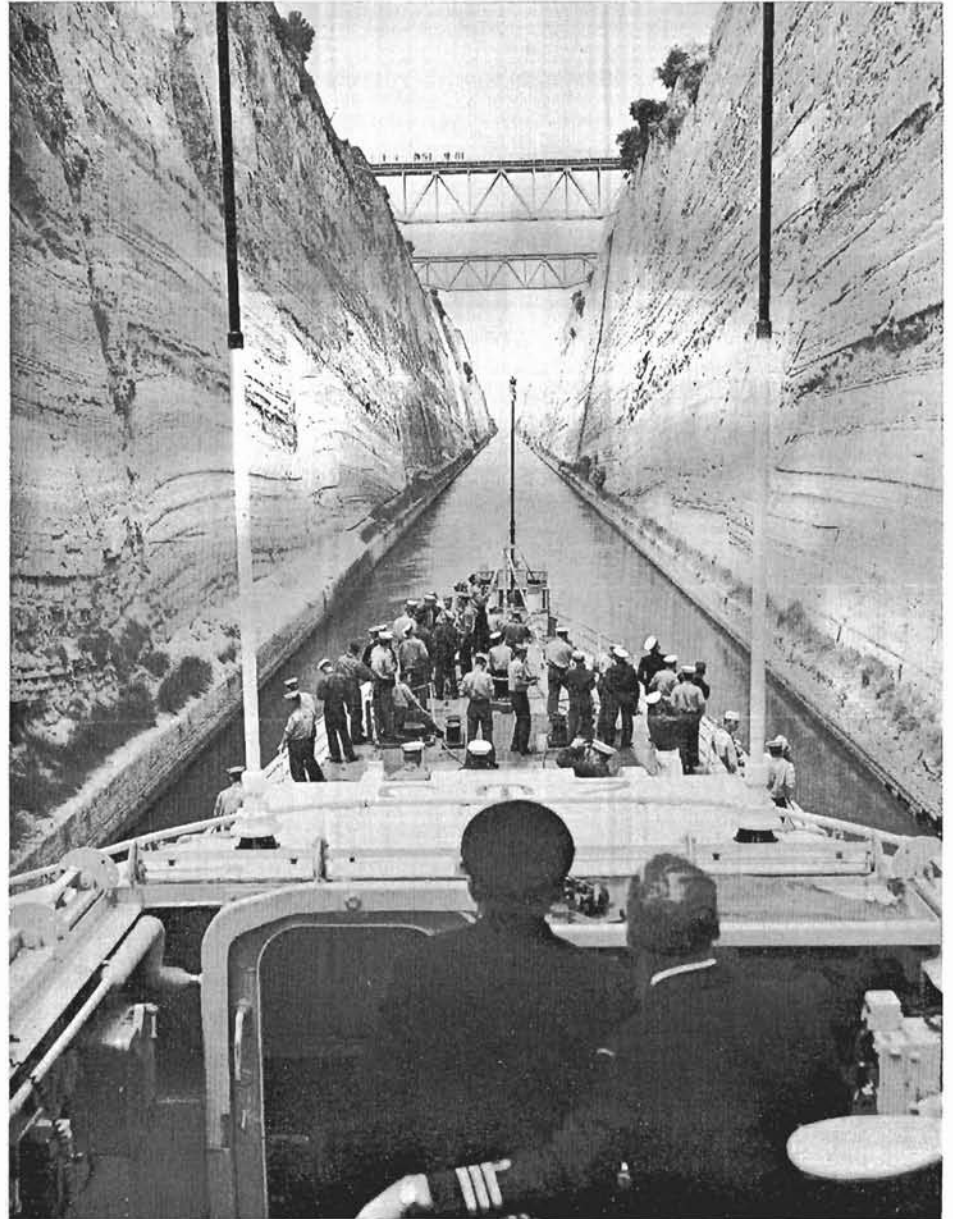

"Please do not scratch matches on the walls." The St. Laurent passes along the famous Corinth Canal following her visit to Piraeus, port of Athens. A tug makes sure the St. Laurent doesn't rub off any paint. (E-74896-284)

show presented in English, French and Greek each evening. A gift from the French government, this hour-long show, done in stereophonic sound and lights, is a dramatic attempt to bring the Acropolis, the heart of Athens, back to life and to allow the audience for a moment a regression of hundreds of years.

On May 13, the *St. Laurent* sailed from Piraeus but before saying goodbye to Greece we steamed along the Corinth Canal and this in itself was an experience. While this canal is only slightly over three miles in length it is remarkable in that the walls of the central portion rise almost vertically in some places to a height of 250 feet, yet the canal is only 69 feet wide. Our amateur photographers took literally hundreds of photos to record the transit of this amazing canal, begun during the reign of the Emperor Nero.

After an unexpected stop in Naples to land an appendicitis case we arrived in La Spezia, Italy, on May 16. A naval base and industrial city of 125,000, La Spezia is so situated that it was possible for most everyone to visit Pisa and Florence, and some also Rome and Milan. Tours had been arranged for Pisa and Florence when we arrived. So great was the interest shown that there was not room on the buses to accommodate everyone. However, little daunted, many of the ship's company went on their own train, bus or scooter.

The Leaning Tower of Pisa seemed to fascinate most. Built in 1174, this bell tower soon developed a tilt, as earth began to give way under one side. Work, as a result had to be stopped. A century later another architect added the top four galleries and attempted to rectify the inclination but the tilt has increased with each passing year. Defy-



The accompanying story suggests that the Leaning Tower of Pisa leaned more than ever after the visit of *St. Laurent* sailors—but maybe not this much more. (E-74896-299)

ing gravity, the Leaning Tower now stands 14 feet out of line, slightly more, it seems, than before our arrival!

It was interesting to note that although a friendly enthusiasm prevailed among the Italians wherever we went,

the language barrier, after some 30,000 miles of steaming, finally came to the fore and proved to be quite frustrating. Fortunately a basic vocabulary was quickly developed when the need was apparent.

Our next port of call on our way to Portsmouth and two weeks of self-maintenance was Gibraltar. Although a brief stop, it proved to be a popular one. We arrived with high hopes of finding there another Singapore or Aden, as far as shopping was concerned. But in this we were soon disillusioned.

The Royal Navy organized a three hour tour of Gibraltar on Saturday afternoon, May 23. The many huge tunnels and caves, old fortifications and, above all, the Barbary apes were most interesting. No one is certain how these apes really got there but there is an old Spanish saying that "when the apes leave the Rock the British will go." Needless to say they are well cared for.

On Sunday, May 24, we sailed from Gibraltar for Portsmouth and arrived Wednesday, May 27. All members of the ship's company were granted a 48-hour special leave and an opportunity to visit relatives and friends and to recount the tale of their five-month voyage.

As this last chapter is being concluded, the *St. Laurent* is preparing to leave Portsmouth and join other units of the First Canadian Escort Squadron in Londonderry, Northern Ireland. Here a joint exercise is scheduled after which the squadron will return to Halifax in mid-July. At that time the ship's company will transfer to HMCS *St. Croix* with the exception of our captain, Cdr. D. D. Lee, and six officers. The *St. Croix* then will proceed to Esquimalt via the Panama Canal, thus completing for most of the ship's company a round-the-world cruise.—L.A.A

The End



IN MEMORY

ON PASSAGE up the English Channel for exercises with the Royal Navy, HMCS *Athabaskan* on June 1 hove to for a remembrance service in the position off the coast of Brittany where the first *Athabaskan* was sunk on April 29, 1944.

Taking passage in the *Athabaskan* was Cdr. John W. Scott, on the staff of the Judge Advocate General, Ottawa. As a survivor of the sinking of the first *Athabaskan*, he was asked to place a wreath on the waves in remembrance of his former ship and shipmates. Sharing in the ceremony was Ldg. Sea. William Lusty, whose brother was lost during the invasion period while serving in HMCS *Regina*. The religious portion of the ceremony was conducted by Chaplain (P) David K. Dickey.

Before placing the wreath on the sea, Cdr. Scott addressed the ship's company.

"In this position, on the morning of April 29, 1944, the first ship bearing the name was sunk during an engagement with enemy destroyers," Cdr. Scott said.



Ldg. Sea. William Lusty, whose brother, AB Frank Lusty, RCNVR, was lost in the sinking of HMCS *Regina* during the invasion period, hands a wreath to Cdr. John W. Scott, a survivor of the sinking of the first *Athabaskan*, to place in the waters of the English Channel in the position where the Tribal class destroyer was sunk on April 29, 1944. The ceremony took place on board the present *Athabaskan* on June 1. The chaplain is Rev. D. K. Dickey. (CCC1-234)

Revised List of D-Day Warships

Attention has been drawn to the fact that the table of HMC Ships engaged in Operation Neptune on June 6, 1944, published in the May 1964 issue of *The Crow's Nest*, was deficient in a number of respects, notably in the omission of the names of 11 steam Bangor mine-sweepers. Also left out was the name of HMCS *Rimouski*, corvette, and HMCS *Stormont*, frigate. Two units of the 260th LCIL Flotilla, which were under repair at the time of Operation Neptune, were listed.

As amended, the list contains the names of 122 ships and smaller craft.

Fleet Destroyers (4)

In the 10th Destroyer Flotilla (RN): *Haida*, *Huron*.

In the 26th Destroyer Flotilla (RN): *Algonquin*, *Sioux*.

Escort Destroyers (9)

11th Escort Group (RCN); *Chaudiere*, *Gatineau*, *Kootenay*, *Ottawa*, *St. Laurent*.

12th Escort Group (RCN): *Qu'Appelle*, *Restigouche*, *Skeena*, *Saskatchewan*.

Frigates (11)

6th Escort Group (RCN): *Cape Breton*, *Grou*, *Outremont*, *Teme*, *Wasquesiu*.

9th Escort Group (RCN): *Matane*, *Meon*, *Port Colborne*, *Saint John*, *Stormont*, *Swansea*.

Corvettes (19)

Alberni, *Baddeck*, *Calgary*, *Camrose*, *Drumheller*, *Kitchener*, *Lindsay*, *Louisburg*, *Lunenburg*, *Mayflower*, *Mimico*, *Moose Jaw*, *Port Arthur*, *Prescott*, *Regina*, *Rimouski*, *Summerside*, *Trentonian*, *Woodstock*.

Minesweepers (16)

(Steam Bangor Class)

In the 4th Minesweeping Flotilla (RN): *Thunder*.

In the 14th Minesweeping Flotilla (RN): *Georgian*, *Guysborough*, *Kenora*, *Vegreville*.

In the 16th Minesweeping Flotilla (RN): *Canso*.

In the 31st Minesweeping Flotilla (RCN): *Bayfield*, *Blairmore*, *Caraquet*,

Cowichan, *Fort William*, *Malpeque*, *Milltown*, *Minas*, *Mulgrave*, *Wasaga*.

Landing Ships (2)

Prince David, *Prince Henry*.

Motor Torpedo Boats (17)

29th MTB Flotilla (RCN): MTBs 459, 460, 461, 462, 463, 464, 465, 466.

64th MTB Flotilla (RCN): MTBs 726, 727, 735, 736, 743, 744, 745, 747, 748.

Landing Craft (44)

260th LCIL Flotilla: LCILs 117, 166, 177, 266, 271, 277, 285, 298, 301.

262nd LCIL Flotilla: LCILs 115, 118, 125, 135, 250, 252, 262, 263, 270, 276, 299, 306.

264th LCIL FLOTILLA: LCILs 255, 288, 295, 302, 305, 310, 311.

528th LCA Flotilla, embarked in the *Prince Henry*: LCAs 736, 850, 856, 925, 1021, 1033, 1371, 1372.

529th LCA Flotilla, embarked in the *Prince David*: LCAs 1057, 1059, 1137, 1138, 1150, 1151, 1374, 1375.



When the RCN Went to War in 1914

Fifty years ago the Royal Canadian Navy went to war for the first time and before the conflict ended some 9,600 officers and men had seen war-time service in the RCN or RCNVR. Hundreds of other Canadians had proceeded to Britain to serve in ships of the Royal Navy or in the Royal Naval Air Service.

An unusual scene, photographed in the autumn of 1914, is the accompanying picture of the ship's company of HMCS Earl Grey (despite the signboard, she was commissioned in the Royal Canadian Navy) taken around the time she was preparing to sail for Archangel, Russia, where she was turned over to the Russian Navy who wanted her for ice-breaking capabilities.

Special gear provided for the journey included padded duffle coats, larrigans (knee-length, oiled moccasins) and caps the like of which the Navy surely cannot have seen before or since. They had enormous ear flaps which were tied together at the top of the cap when not in use. One individualist appears to be wearing a Balaclava.

The ship made the journey to northern Russia safely, with a brief stop at St. John's Nfld., for repairs, but there were casualties when the ship in which some of them were returning to England foundered.

The Earl Grey was built by the Canadian government as a freight and passenger steamer for service in Northumberland Strait between Prince Edward Island and the mainland. She was the third ship commissioned in the RCN—after the cruisers Niobe and Rainbow—having served under the White Ensign briefly in 1912 during a cruise by the Governor-General, the Duke of Connaught. She was sold to Russia for \$493,000.

The Earl Grey is still steaming the White Sea as the Fyodor Litke, according to the current edition of Jane's Fighting Ships. During her earlier Russian career she was known as the Kanada.

The original, from which this picture has been copied, is owned by former Chief Shipwright W. J. Fry.

"The Athabaskan was a proud ship, a happy ship, and above all, an efficient ship. As a member of the crack Tenth Destroyer Flotilla, comprised of Royal Navy and Royal Canadian Navy Tribals, she had a top reputation for efficiency and getting things done.

"Early in 1944, the Tribals assumed their attack role in the English Chan-

nel. Our objective was to seek out and destroy enemy surface forces that could interfere with the invasion fleet, and possibly upset the whole invasion.

"Because of enemy aircraft we carried out our sweeps off the French coast at night, at speeds in excess of 30 knots, with radar silence. We engaged in a number of gun fights with

enemy destroyers and E-boats; and just two nights prior to our sinking, we assisted in the sinking of an Elbing class destroyer, and the damaging of three others. On the morning of April 26, in this area, we engaged a force of destroyers and E-boats. This resulted in the loss of the Athabaskan and one of the enemy destroyers.

"I think it is important that those of you who wear the name of this ship should appreciate that it is a *proud* name respected by many navies. Your recent rescue of merchant seamen from the Liberian tanker *Amphialos* brought the name of the *Athabaskan* again to the fore; and I am sure those we are honouring here today would take pride in your endeavours.

"In paying my respects to former shipmates and in your doing honour to your predecessor, we join in the knowledge that the best traditions of the Royal Canadian Navy are being cherished and carried forward."

Cdr. Scott, who had been a lieutenant in charge of gunnery control in the *Athabaskan*, was the only surviving officer picked up by HMCS *Haida*. He was in critical condition as a result of severe burns and was hospitalized in Britain, later being returned to Canada for further medical treatment.

There was a strange footnote to his rescue. In 1945, Cdr. Scott's father, William Scott, received a letter from the Mayor of Plouescat, France. Written in French, it told of the bodies of the *Athabaskan's* sailors being washed up

on the beach, from which they were recovered and given a full funeral and proper burial by the residents of the French fishing village, contrary to the orders of the Germans.

Among the bodies was one on which were found letters and photographs belonging to "Sub-Lt. Scott", who had been paid last respects along with the others.

What had happened was that Cdr. Scott's cabin mate, Sub-Lt. A. R. Nash, had picked up a lifejacket in which the personal documents had been stowed and was wearing it when he lost his life.

On May 5 of this year, the residents of Plouescat again paid their respects to the memory of the 59 *Athabaskan* sailors whose bodies rest in the cemetery near the Brittany village. The ceremony was part of a large program of Franco-Canadian friendship and remembrance days in the Finistère, the most easterly portion of Brittany. Said the *Télégramme de Brest*:

"The entire population of Plouescat joined in paying their respects and in the memorial service when . . . Col. Guimond, Canadian Military Attaché,

representing His Excellency Ambassador Jules Léger, placed a wreath at the foot of the inscribed monument erected in the cemetery in memory of the valiant Canadian sailors who gave their lives for a land which, for many of them, as was pointed out by Col. Guimond and by Mr. Charles Luisser, Delegate-General of the Quebec Government in Paris, was the birthplace of their ancestors.

"Honours were rendered by a detachment of seamen from the Brest Security Company, under the command of Chief Marine Petty Officer Perrin, and by the Navy band, under Bandmaster Gory."

A small girl, carrying a bouquet of flowers, stood by each grave as the colours were hoisted. Wreaths were placed, the audience stood a minute in silence and then the national anthems of Canada and France were played.

The ceremonies ended with a parade and official reception.

On the anniversary of D-Day, June 6 HMCS *Outremont* took part in Channel ceremonies commemorating Canadian participation in the invasion of Europe.



There was swift co-operation between the U.S. Coast Guard and the RCN's Pacific Command on July 10 when a Seattle skindiver, who had been diving in the San Juan Island area, suffered a severe attack of the bends. He was flown to Esquimalt Harbour in a USCG Albatross aircraft, transferred to a dinghy and sped by ambulance to the recompression chamber at the Operational Diving Establishment in nearby Colwood. (E-77472) The mission was co-ordinated by the RCAF Search and Rescue Headquarters in Vancouver. (E-77472)

RETIREMENTS

CPO JAMES SINCLAIR BAZLEY, CD and 1st Clasp; C1WR4; joined RCNVR April 15, 1939, transferred to RCN Aug. 17, 1941; served in London naval division, *Stadacona*, *Venture*, *Avalon*, *Bytown*, *Protector*, *Peregrine*, *Micmac*, *Nootka*, *La Hullose*, *Haida*, *Cornwallis*, *Naden*, *Hochelaga*, *Shearwater*; retired July 27, 1964.

CPO LESTER OLAF LORAN BELL, CD; C1HT4; joined RCNVR Sept. 30, 1936; served in Toronto naval division, *Stadacona*, *Naden*, *Annapolis*, *Avalon*, *Shelburne*, *York*, *Bytown*, *Carleton*, *Warrior*, *Magnificent*, *St. Laurent*, *Cape Scott*, *Haida*; retired July 13, 1964.

CPO JEREMIAH BLYTHE, CD; C1ER4; joined July 31, 1939; served in *Naden*, *Stadacona*, *Ottawa*, *Annapolis*, *Chaleur II*, *Dunver*, *Avalon*, *Peregrine*, *Moncton*, *Coaticook*, *Crescent*, *Givenchy*, *Rockcliffe*, *Athabaskan*, *Beacon Hill*, *Sault Ste. Marie*, *Magnificent*, *Cayuga*, *Ontario*, *Margaree*, *Saguenay*, *New Glasgow*; retired July 30, 1964.

CPO LEIGH ORWELL BOULTER, CD; C2ER4; joined RCNVR April 30, 1940; transferred to RCN March 22, 1945; served in Charlottetown naval division, *Stadacona*, *Saguenay*, *Assiniboine*, *Cornwallis*, *Wasaga*, *Avalon*, *Ottawa*, *Peregrine*, *Micmac*, *Warrior*, *Magnificent*, *Haida*, *Wallaceburg*, *Algonquin*, *Donnacona*, *Lanark*, *Bonaventure*; retired July 3, 1964.

CPO CHARLES THOMPSON CLUFF, CD; C2BN4; joined July 31, 1939; served in *Naden*, *Stadacona*, *St. Laurent*, *Amherst*, *Morden*, *Avalon*, *Kokanee*, *Armentieres*, *Givenchy*, *Bytown*, *Rockcliffe*, *Ontario*, *Unicorn*, *Antigonish*, *Porte Quebec*, *Cornwallis*, *St. Therese*; retired July 30, 1964.

CPO ALVIN EDWARD COE, C1PT4; joined July 31, 1939; served in *Naden*, *Stadacona*, *Restigouche*, *Ambler*, *Avalon*, *Assiniboine*, *Cornwallis*, *Warrior*, *Magnificent*, *Cataract*, *Shearwater*, *Algonquin*, *Cornwallis*, *Cape Scott*; awarded RCN Long Service & Good Conduct Medal; retired July 30, 1964.

CPO CHARLES LEWIS, CD and 1st Clasp; C2BN4; joined RCNVR April 6, 1939; transferred to RCN Oct. 9, 1940; served in Vancouver naval division; *Naden*, *Stadacona*, *Givenchy*, *NOIC Vancouver*, *Wolf*, *Cornwallis*, *Canso*, *Caracquet*, *Mirimachi*, *Lockeport*, *Protector II*, *Dunvegan*, *Dundas*, *Chaleur*, *Peregrine*, *Niobe*, *Louisburg*, *Saint John*, *Portage*, *Charlottetown*, *Rockcliffe*, *Ontario*, *Beacon Hill*, *Naden*, (YNG 185), *Digby*, *Quadra*, *Ontario*, *Antigonish*; retired July 21, 1964.

CPO FRANCIS JOHN MALCOLM; C2ER4; joined July 31, 1939; served in *Stadacona*, *Skeena*, *Avalon*, *Chedabucto*, *Hochelaga*, *Brantford*, *St. Francis*, *Peregrine*, *Scotian*, *Cornwallis*, *Niobe*, *Grou*, *St. Pierre*, *Middlesex*, *Kincardine*, *Cataract*, *Portage*, *Iroquois*, *Haida*, *Huron*, *Quebec*, *Magnificent*, *Bytown*, *St. Laurent*, *Assiniboine*, *Sioux*, *Columbia*; awarded Long Service & Good Conduct Medal; retired July 30, 1964.

CPO THOMAS MARTIN MOTTERSHEAD, CD; C1PT4; joined July 31, 1939, served in *Naden*, *Stadacona*, *Ottawa*, *Beaver*, *Lethbridge*, *Chaleur II*, *Niobe*, *Monnow*, *HMS Ferret*, *Grou*, *Beacon Hill*, *Peregrine*, *Givenchy*, *Ontario*, *RCN College*, *Cornwallis*, *Shearwater*, *Magnificent*, *D'Iberville*, *Bonaventure*; retired July 30, 1964.

enched, *Ontario*, *RCN College*, *Cornwallis*, *Shearwater*, *Magnificent*, *D'Iberville*, *Bonaventure*; retired July 30, 1964.

CPO KENNETH MARTIN NEAL; CD; C1ET4; joined July 31, 1939; served in *Naden*, *Stadacona*, *Ottawa*, *Melville*, *Cornwallis*, *Camrose*, *Niobe*, *HMS Marlborough*, *Uganda*, *Ontario*, *Cedarwood*, *Athabaskan*, *Jonquiere*, *Assiniboine*; retired July 30, 1964.

OFFICERS RETIRE

CD. OFF. JOHN BLYTHE BING, CD, joined RCNVR as an ordinary seaman June 16, 1938; promoted to acting commissioned gunner (TAS) Nov. 11, 1955; served in *Naden*, *Malaspina*, *Sans Peur*, *Stadacona*, *HMS Dominion*, *Niobe*, *HMS Nimrod*, *Buctouche*, *Canso*, *Chignecto*, *Cornwallis*, *Chatham*; transferred to RCN as able seaman Aug. 3, 1945; served in *Naden*, *Stadacona*, *Ontario*, *Sault Ste. Marie*, *Sioux*, *Niobe*, *HMS Vernon*, *Crusader*, *Cornwallis*, *Shelburne*, *Bonaventure*; last appointment, *HMCS Stadacona*, for Weapons Division; commenced leave July 27, 1964; retires on Feb. 20, 1965.

CD. OFF. CHARLES WILLIAM BOURGEOIS, joined RCN as a boy seaman Sept. 13, 1937; promoted to acting commissioned communications officer, March 15, 1957; served in *Naden*, *Stadacona*, *HMS Victory I*, *Allaverdy*, *Assiniboine*, *St. Laurent*, *HMNS Lincoln*, *St. Hyacinthe*, *Avalon*, *Bittersweet*, *Arethusa*, *Niobe*, *Glasgow*, *Uganda*, *Aldergrove*, *Ontario*, *Quebec*, *Shearwater*, *Star*, *Cornwallis*, *James Bay*, *Fraser*, *Crescent*, *Assiniboine*, *Shelburne*; last appointment, *Shelburne*; commenced leave July 22, 1964; retires on March 2, 1965.

LT.-CDR. KENNETH ROBERT DAUPHINEE, CD, joined RCN as a victualling assistant July 12, 1937; promoted to acting warrant supply officer on June 1, 1942; served in *Stadacona*, *Venture*, *Ottawa*, *Prince Henry*, *Cornwallis*, *Naden*, *Givenchy*, *Niobe*, *HMS Landrail*, *Warrior*, *Bytown*, *Star*, *Shearwater*, *Hochelaga*, *Bonaventure*; last appointment, *HMCS Naden*, on Staff of Commodore Superintendent Pacific Coast; commenced leave July 20, 1964; retires on March 2, 1965.

LT. HENRY ALBERT GEORGE DEACON, CD, joined RCNVR as a stoker 2nd class Aug. 14, 1928; transferred to RCNR as stoker 1st class Feb. 18, 1929; promoted to acting warrant engineer on Oct. 1, 1943; served in *Naden*, *Armentieres*, *Skeena*, *Nootka*, *Prince Robert*, *Alberni*, *Avalon II*, *Stadacona*, *Baddeck*, *Venture*, *Goderich*, *Cornwallis*, *Hochelaga*, *Guelph*, *Grou*, *Givenchy*; demobilized Aug. 1, 1946; entered RCN as engine room artificer 4th class Aug. 2, 1946; promoted to acting warrant engineer on March 1, 1948; served in *Malahat*, *Givenchy*, *Uganda*, *Rockcliffe*, *Naden*, *Ontario*, *New Glasgow*; last appointment, *HMCS Naden*, on staff of Officer-in-Charge Royal Canadian Navy Depot Esquimalt as Staff Engineering Personnel; commenced leave July 3, 1964; retires on Jan. 28, 1965.

LT.-CDR. LAWRENCE PATRICK FEARS, CD, joined RCN as a boy seaman Sept. 13,

CPO BERNARD LLOYD SILVER; C2ST4; joined July 31, 1939, served in *Naden*, *Stadacona*, *Ottawa*, *Avalon*, *Cornwallis*, *St. Laurent*, *Kootenay*, *Shediac*, *Burrard-J833*, *Shediac*, *Givenchy*, *Prince Robert*, *New Waterford*, *Uganda*, *Ontario*, *Discovery*, *Naden* (YNG 185), *Naden* (Pat Bay), *Hochelaga*, *Churchill*, *Margaree*, *Naden* (VV 33); awarded RCN Long Service & Good Conduct Medal; retired July 30, 1964.

1937; demobilized June 28, 1945; served in *Naden*, *Fraser*, *Stadacona*, *Niobe*, *Iroquois*, *St. Hyacinthe*, *Rimouski*, *Avalon*; re-entered the RCN as acting sub-lieutenant (SB) Oct. 31, 1950; served in *Discovery*, *Naden*, *Stadacona*, *Bytown*; last appointment, *HMCS Naden*, for Naval Hospital as Pharmacist and on staff of Officer-in-Charge Naval Supply Depot for Medical Stores; commenced leave July 5, 1964; retires on Nov. 29, 1964.

LT.-CDR. ALLAN CHARLES KENT, CD, joined RCNVR as an ordinary seaman July 3, 1933; transferred to RCN as acting engine room artificer 4th class Jan. 8, 1937; promoted to acting warrant engineer on Jan. 15, 1943; served in *Naden*, *Armentieres*, *Fraser*, *Margaree*, *Stadacona*, *Cornwallis*, *Port Colborne*, *Avalon*, *Dauphin*, *Winnipeg*, *New Waterford*, *Givenchy*, *Warrior*, *Niobe*, *Magnificent*, *Bytown*, *Cornwallis*; last appointment, *HMCS Naden*, on staff of Resident Naval Overseer, Victoria; commenced leave July 9, 1964; retires on Feb. 24, 1965.

CAPTAIN DUDLEY GAWEN KING, DSC, CD, joined RCNVR as an acting lieutenant Oct. 11, 1939; served in *Naden*, *Stadacona*, *Chaleur II*, *King's*, *Venture*, *Arvida*, *Hochelaga*, *Stettler*, *Provider*; transferred to RCN as lieutenant-commander Jan. 8, 1946; served in *Provider*, *Scotian*, *Stadacona*, *Niobe*, *Bytown*, *Athabaskan*, *Naden*, *Shearwater*, *Algonquin*, *Niagara*; last appointment, *HMCS Niagara*, on attachment to Supreme Allied Commander Atlantic as Assistant Chief of Staff Personnel and Administration; commenced leave July 27, 1964; retires on Feb. 21, 1965.

CHAPLAIN (RC) HUGH MATTHEW McGETTIGAN, entered RCN (R) as Chaplain (RC) June 23, 1953; transferred to RCN Jan. 8, 1954; served in *Malahat*, *Naden*, *Ontario*, *Antigonish*, *Quebec*, *Assiniboine*, *Saguenay*, *New Glasgow*, *Sussexvale*, *Fraser*, *Royal Roads*; last appointment, *HMCS Royal Roads*, for Canadian Services College and Naval Dependents' Housing, Belmont Park, as Chaplain (RC); commenced leave July 16, 1964; retires on Oct. 13, 1964.

CDR. OTTO HENRY MESECK, CD, joined RCNVR as a probationary sub-lieutenant April 19, 1943; served in *Carleton*, *Cornwallis*, *Bytown*; transferred to RCN as lieutenant (L) Dec. 21, 1945; served in *Bytown*, *Stadacona*, *Huron*, *Naden*, *Quebec*, *Star*, *Discovery*, *York*; last appointment, *HMCS York*, as Principal Naval Overseer, Ontario; commenced leave July 6, 1964; retires on Jan. 8, 1965.



HMCS Lanark by day and by night is shown in these two pictures, taken by Patrick E. Griffiths, of Hamilton, on July 3. The first picture shows the Lanark, assigned to the Great Lakes reserve training program, entering Hamilton Bay. In the lower one she is alongside at the Great Lakes Training Centre.

LT.-CDR. STUART GRANT MOORE, CD, joined RCN as a cadet Aug. 26, 1938; served in *Stadacona*, *HMS Excellent*, *HMS Erebus*, *HMS Vindictive*, *HMS Diomedé*, *Restigouche*, *St. Clair*, *Niobe*, *HMS Vernon*, *HMS Drake*, *Uganda*, *Naden*, *Ontario*, *Quebec*, *Iroquois*, *Fortune*, *Bytown*; last appointment, Naval Headquarters, on staff of Assistant Director Naval Manning (Programs); commenced leave July 20, 1964; retires on Feb. 21, 1965.

CD OFF JOHN ALBERT NORRIS, served in Royal Navy July 11, 1935, to June 6, 1952; joined RCN as an able seaman June 7, 1952; promoted to acting commissioned gunner on

June 3, 1959; served in *Niobe*, *Cornwallis*, *Stadacona*, *Magnificent*, *Cape Breton*, *Naden*, *HMS Excellent*, *Cap de la Madeleine*; last appointment, HMCS *Stadacona*, for Weapons Division; commenced leave July 8, 1964; retires on Jan. 31, 1965.

CDR. CHARLES RODGER PARKER, DSC, CD, joined RCNVR as a probationary sub-lieutenant April 23, 1941; served in *Royal Roads*, *Naden*, *Niobe*, *Stadacona*, *HMS Uganda*; transferred to RCN as lieutenant Jan. 17, 1946; served in *Uganda*, *Naden*, *Bytown*, *Athabaskan*, *Cayuga*, *Stadacona*, *Ottawa*; last appointment, HMCS *Naden*, on

staff of Maritime Commander Pacific as Chief Staff Officer Plans; commenced leave July 6, 1964; retires on Jan. 22, 1965.

LT. LLOYD WESLEY TURNER, CD, joined as a boy seaman July 12, 1937; promoted to acting commissioned officer (SB) on Sept. 22, 1952; served in *Naden*, *Fraser*, *Stadacona*, *Givenchy*, *Quatsino*, *Avalon*, *Three Rivers*, *Chaleur*, *Jonquiere*, *Arnprior*, *Cornwallis*, *Peregrine*, *Quinte*, *Bytown*, *Cornwallis*, *Algonquin*; last appointment, HMCS *Stadacona*, on staff of Flag Officer Atlantic Coast as Assistant Staff Officer (Information); commenced leave July 8, 1964; retires on Feb. 14, 1965.

Naval Lore Corner

Number 129 THE UBIQUITOUS FAIRMILES

SOME 750 OF THESE STURDY LITTLE WOODEN VESSELS WERE BUILT DURING WORLD WAR II (102 OF WHICH SERVED IN THE R.C.N.). OF SEVERAL TYPES AND CLASSIFICATIONS, THEY SERVED IN A VARIETY OF ROLES WITH COASTAL FORCES. THEY AVERAGED 65-75 TONS, WITH SPEEDS OF FROM 20 TO 36 KNOTS, DEPENDING ON THE TYPE OF ENGINES FITTED. COMPLEMENTS WERE ABOUT 12 TO 16....

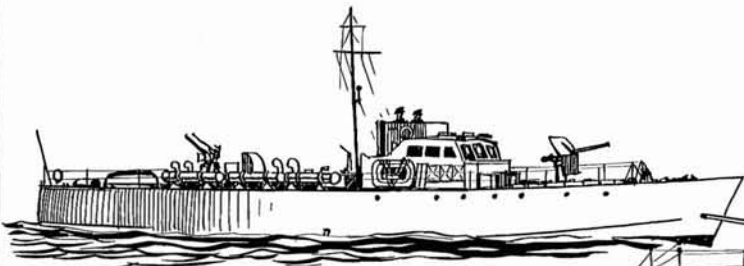

FAIRMILE TYPE 'A' CONVERTED AS A MINELAYER WITH 6 GROUND MINES AND FUNNEL REMOVED

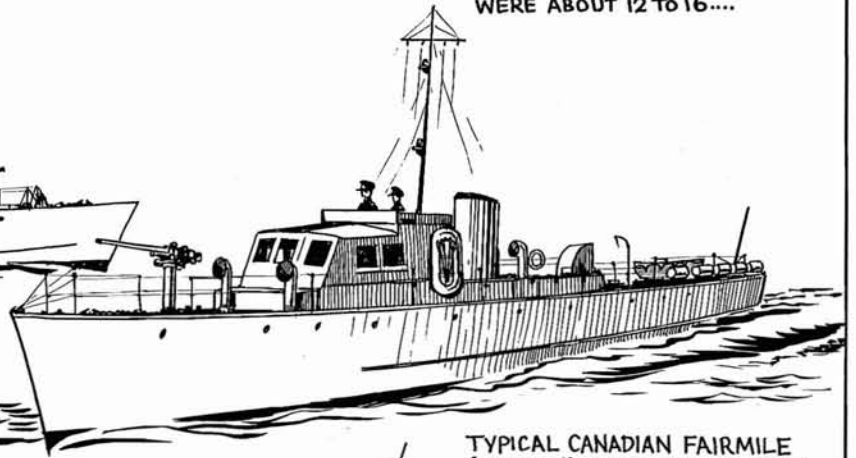

TYPICAL CANADIAN FAIRMILE (TYPE 'B'), USED EXTENSIVELY BY THE R.C.N. ON COASTAL A/S PATROL. ARMED WITH DEPTH CHARGES...

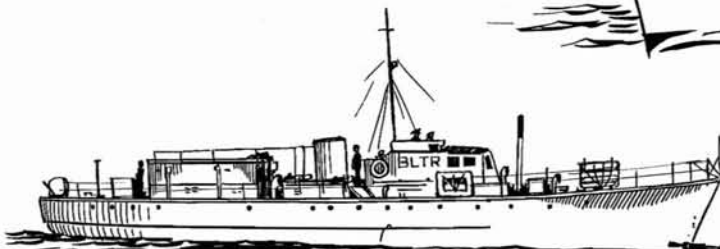

SEVERAL FAIRMILES WERE OPERATED BY THE ARMY AS SEA-GOING AMBULANCES (ABOVE)

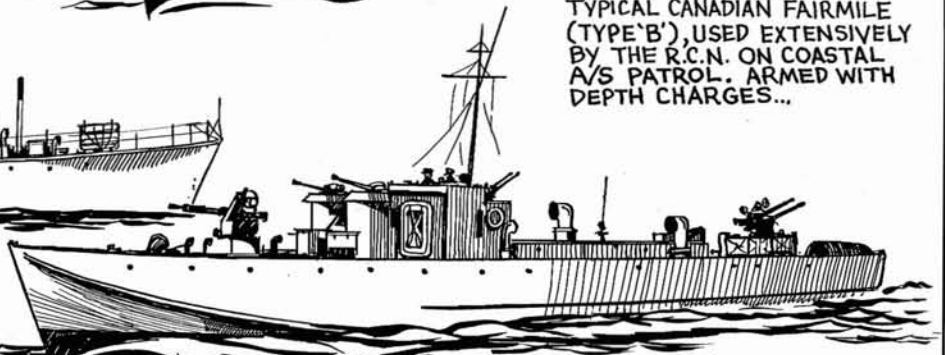

FAIRMILE (TYPE 'D') FITTED AS A MOTOR GUNBOAT. ARMED WITH ONE 2-PDR., TWIN 20 MM, 2 TWIN .5 MACHINE GUNS AND 2 TWIN .303 MACHINE GUNS.

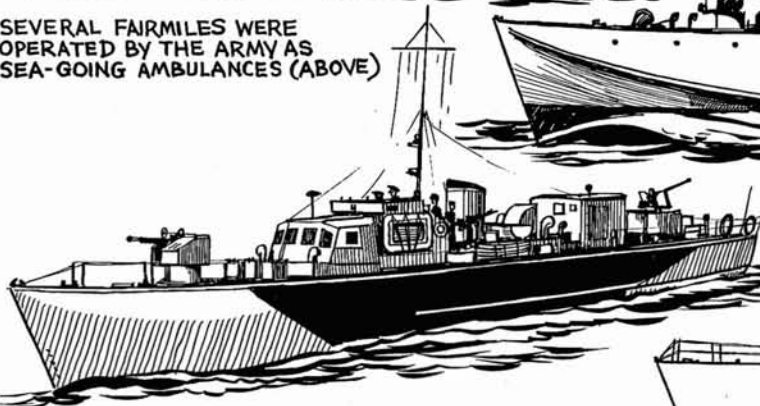

FAIRMILE FITTED AS RESCUE LAUNCH (ABOVE), WITH CABIN AMIDSHIPS FOR SURVIVORS..

AFTER THE WAR MANY FAIRMILES WERE CONVERTED TO CIVILIAN USE. TYPICAL CONVERSIONS WERE THE "GULF WING" (RIGHT) REFITTED AS A COASTAL PASSENGER-FREIGHTER ON CANADA'S WEST COAST, AND THE YACHT "PACIFIC GOLD" (UPPER RIGHT) ...EX-M.L.124...

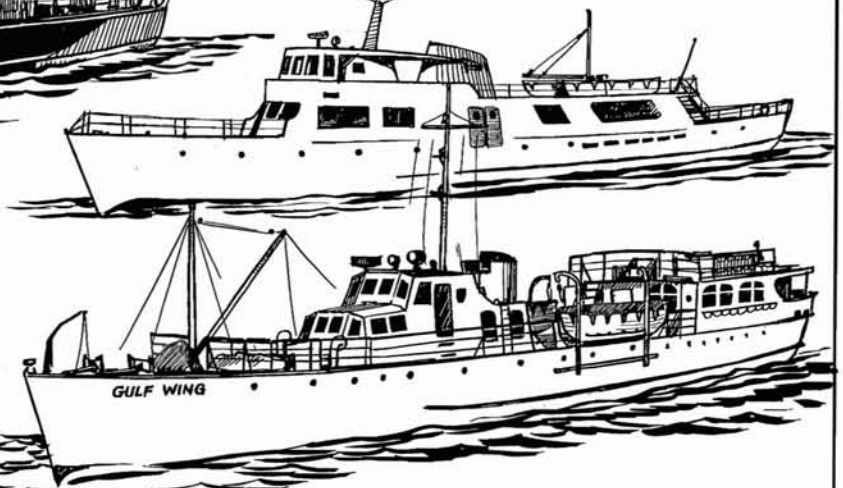

CANADA
POSTAGE PAID
PORT PAYÉ

*If undelivered,
return COVER WITH CONTENTS to:*
The Queen's Printer, Ottawa, Canada

*En cas de non-livraison,
retourner cette PUBLICATION INTACTE à:*
L'Imprimeur de la Reine, Ottawa, Canada



The CROWSNEST



Vol. 16, No. 9

September, 1964



The CROWSNEST

Vol. 16 No. 9

THE ROYAL CANADIAN NAVY'S MAGAZINE

SEPTEMBER 1964

CONTENTS

	Page
<i>RCN News Review</i>	2
<i>Haida, Inc.</i>	5
<i>Officers and Men</i>	9
<i>Weddings and Births</i>	9
<i>RN Sub—RCN Captain</i>	13
<i>Nabob Reunion</i>	14
<i>Apprentice Plan</i>	15
<i>Here and There in the RCN</i>	19
<i>Afloat and Ashore</i>	21
<i>Royal Marines 300 years Old</i>	22
<i>Books for the Sailor</i>	23
<i>The Navy Plays</i>	25
<i>Retirements</i>	27
<i>Naval Lore Corner No. 130</i>	<i>Inside Back Cover</i>

LADY OF THE MONTH

Chronologically speaking, it's not HMCS *Assiniboine's* turn to appear as "Lady of the Month" on the opposite page. She has earned the honour, however, by reason of an important social event of the past summer—her wedding to the Sea King.

The picture shows the Sea King (CHSS-2) about to land on the *Assiniboine's* flight deck. The small rectangle is the "bear trap", a device which holds the helicopter firmly to the deck, yet permits its movement to and from the hangar.

The "bear trap" represents just a small portion of the considerable Canadian ingenuity that went into the development of an anti-submarine weapons complex whose object is to reduce the safety margin of modern high-speed submarines. (DNS-33910)

Negative numbers of RCN photographs reproduced in *The Crowsnest* are included with the caption for the benefit of persons wishing to obtain prints of the photos.

This they may do by sending an order to the Secretary Defence Staff, Canadian Forces Headquarters, Ottawa, quoting the negative number of the photograph, giving the size and finish required, and enclosing a money order for the full amount, payable to the Receiver General of Canada.

Sizes, finish and the National Defence standardized prices, follow:

4 x 5 (or smaller) glossy finish only ..	\$.10
6½ x 8½ glossy finish only40
8 x 10 glossy or matte finish50
11 x 14 matte finish only	1.00
16 x 20 " " "	3.00
20 x 24 " " "	4.00
30 x 40 " " "	8.00

SUBSCRIPTION RATE

The Crowsnest may be subscribed for at the rate of \$2 a year; outside of North America, \$3. Orders, accompanied by cheque or money orders payable to the Receiver General of Canada, should be sent to:

THE QUEEN'S PRINTER,
OTTAWA, Ontario,
Canada

Communications, other than those relating to subscriptions, should be addressed to:

EDITOR,
The Crowsnest,
Canadian Forces Headquarters,
OTTAWA, Ontario.

The Cover—A proud and beautiful ship, cleaving the blue waters of the Pacific, HMCS *Qu'Appelle* is portrayed during exercises off the West Coast during the past summer. The *Qu'Appelle* was commissioned at Lauzon, Que., in September 1963 and joined the Pacific Command last spring. She is part of the Second Canadian Escort Squadron. (E-76710)



RCN NEWS REVIEW

The latest addition to the Pacific Command is HMCS St. Croix, which arrived in Esquimalt August 28. She is manned by a ship's company that left Victoria Jan. 7 in HMCS St. Laurent for Commonwealth naval exercises in the Indian Ocean, and then steamed around the world for Halifax. HMCS St. Croix is commanded by Cdr. John Hertzberg. (E-77933)

Tug Survivors Landed in U.S.

Twelve survivors from the U.S. tug *Sea Wolf*, destroyed by fire on Aug. 15 while 950 miles northeast of Honolulu, were brought to San Francisco by ships of the Fourth Canadian Escort Squadron, under Captain D. S. Boyle.

The RCN warships, on a training cruise with ROTP cadets embarked, arrived on the scene of the fire soon after the USCGS *Pontchartrain*.

The U.S. Coast Guard vessel had no medical officer on board and the survivors were accordingly transferred to the Canadian ships.

The chief engineer of the tug suffered second degree burns and exposure but was successfully treated by HMCS *Jonquiere's* medical officer.

Five Ships at Charlottetown

Ceremonies marking the 100th anniversary of the Charlottetown conference of the Fathers of Confederation were attended in the Prince Edward Island capital by five RCN warships.

Present for the Aug. 29 ceremonies were the *Crescent*, *Athabaskan*, *Algonquin*, *Yukon* and *Cape Scott*.

A guard and band from HMS *Cornwallis* performed the Sunset Ceremony and a reception on board the *Cape Scott* was honoured by the presence of the Prime Minister of Canada, Rt. Hon. L. B. Pearson.

Notes Decide RCN Bermuda Status

The Secretary of State for External Affairs, Hon. Paul Martin, announced Sept. 11 that an exchange of notes which took place in London that day between the Canadian and British Governments constitutes an agreement regarding the status of Canadian forces in Bermuda.

The agreement was made necessary by the stationing in Bermuda of Royal

Canadian Navy personnel to operate a naval radio station and by the more extensive use being made by RCN ships of Bermuda as an operating base.

The agreement provides for establishment of the radio station and regulates such matters as jurisdictional authority, claims, immunities and other related problems connected with the presence in Bermuda of Canadian armed forces personnel on official duty. These arrangements have been made with the full agreement of the Bermuda Government.

Escort Provided For Royal Yacht

With the assent of Her Majesty Queen Elizabeth an escort of RCN warships was arranged for the portions of her visit to Canada in October during which she was to be on board HM Yacht *Britannia*.

Her Majesty and His Royal Highness the Prince Philip were scheduled to arrive at RCAF Station Summerside, P.E.I., on the early evening of October 5. The Royal Party was to proceed directly to the *Britannia* anchored off Summerside with its naval escorts, with arrival in Charlottetown scheduled for the morning of October 6.

Chosen as escort were HMC Ships *Nipigon*, *St. Laurent*, *Yukon* and *Assiniboine*, commanded by Commanders D. R. Saxon, D. D. Lee, R. W. Cocks and W. S. Blandy respectively.

Admiral Helps To Rescue Boys

Three youngsters whose boat got in trouble in Esquimalt Harbour got high-class help in late August, according to *The Sun*, Vancouver.

Rear-Admiral W. M. Landymore, Flag Officer Pacific Coast, helped rescue the trio after the engine of their small outboard motorboat failed and winds began pushing the craft towards rocks on shore.

The admiral, his son John, 14; his steward, Ldg. Sea. Norman Grove, and a friend of the admiral's son pulled the boys ashore in front of the Admiral's residence in HMC Dockyard.

The three boys, David George, 13; his brother Lewis, 11, and a cousin, Alfred Kietlah, 13, had set out on a fishing trip. The soaked and shivering lads were taken to the admiral's home for a cup of hot cocoa and cookies and later driven home in a naval transport car.

Rear-Admiral Jeffrey V. Brock, Flag Officer Atlantic Coast, was to embark in the *Assiniboine* on October 5 at Summerside and disembark at Quebec City on October 12 on completion of the escort duties.

The four destroyer escorts are units of the First Canadian Escort Squadron, commanded by Captain J. P. T. Dawson.

Defence Chief Visits East Coast

Canada's new Chief of the Defence Staff, Air Chief Marshal Frank R. Miller in September paid his first visit to the Maritime Command Atlantic since his Aug. 1 appointment.

Air Chief Marshal Miller was greeted by Rear-Admiral J. V. Brock, Maritime Commander Atlantic, and later met senior officers of the three services and addressed officers and men stationed in the Atlantic Command.

He also conferred with Admiral H. P. Smith, U.S.N., Supreme Allied Commander Atlantic, who arrived in Halifax on Sept. 2.

Made-in-Canada 'Copter Accepted

The first Canadian-assembled military helicopter, a Sikorsky CHSS-2 (Sea King) left United Aircraft of Canada Limited's Longueuil helicopter plant on August 27 after a brief ceremony during which the aircraft's logs were passed over to the Royal Canadian Navy. The helicopter is one of 20 to be produced for the RCN.

Present at the "fly-away" ceremony were UACL President T. E. Stephenson, R. G. (Bob) Raven, helicopter manager, Lt.-Cdr. S. W. Grossmith, head of the Naval Aircraft Technical Liaison Office in Longueuil, and Lt.-Cdr. E. A. Fallen and Lt.-Cdr. Sheldon M. Rowell, both of *Shearwater*.

The CHSS-2 is a Canadian version of the record-breaking Sikorsky HSS-2 (SH3A) helicopter, built by United Aircraft of Canada Limited for the Royal Canadian Navy. It is known as the most technologically advanced helicopter in contemporary military operations.

The CHSS-2, equipped with automatic stabilization equipment and doppler navigation radar, possessing the ability to operate on a round-the-clock basis in practically any weather, powered by twin-turbine engines delivering a total of 2,500 SHP, capable of landing upon water, and laden with detection equipment and killer weapons, is a formidable foe to any alien submarine.

The aircraft embodies a winch-down system whereby the helicopter is posi-

tively secured to the destroyer flight deck upon landing. In conjunction with a flight-deck-mounted centring and moving mechanism and the "bear trap", an automatic fold feature on the tail rotor pylon, safe landings and subsequent hangar stowage are possible in seas which induce a lateral ship's roll up to 31° each side of vertical and a longitudinal pitching up to 8°. These extremities are reduced by roll-damping equipment in the ship.

UNTD Cruise Last of Season

Four ocean escorts of the Seventh Canadian Escort Squadron sailed July 31 from Halifax with 120 cadets on the third and last University Naval Training Division cruise of 1964.

HMC Ships *Fort Erie*, *New Waterford*, *Inch Arran* and *Victoriaville*, each carrying approximately 30 cadets, took part in training cruise Charlie.

The four ocean escorts visited Torbay and Chatham, England, after which they separated and carried out individual training. Between training periods the ships visited other U.K. ports and then joined up at Bantry Bay, Eire, on August 26 to return to Halifax, September 2.

Japanese Ships On Courtesy Visit

Four destroyer escorts of the Japanese Maritime Self-Defence Force arrived at HMC Dockyard, Esquimalt, on Aug. 26 for a four-day visit to the Pacific Command.

The ships—which make up the Japanese Maritime Self-Defence Force's Second Training Squadron—were headed by the *Teruzuki* (which means "Shining Moon"), a 2,350-ton, 387-foot warship built in Japan. On board was Rear-Admiral Kazutoshi Kuhara, Japan's senior sea-going officer.

Other ships of the squadron were:

Ariake ("Dawn Twilight"), a U.S.-built Fletcher class destroyer of 2,050 tons and 376 feet overall;

Yugure, ("Evening Dusk"), 2,050 tons and 376 feet overall, also a U.S.-built Fletcher class destroyer, and

Makinami, ("Roller Wave"), 1,700-tons, 257-foot Japanese-built warship.

A total of 68 firings were made as the Japanese squadron entered Esquimalt Harbour—a 21-gun national salute fired by the *Teruzuki*, a 21-gun return salute by a naval battery at Black Rock in HMC Dockyard, a 13-gun salute to the visiting admiral, and a return 13-gun salute.

Sports, social events and tours were just a few of the many activities par-

ticipated in by the 1,200 Japanese naval personnel during their visit. The visitors included 83 officers, nearly 900 men, 160 naval cadets under training and 19 civilians including eight Japanese newspapermen.

For visiting Admiral Kuhara, the four days were busy ones. Immediately after the ships had secured, he was welcomed by Rear-Admiral W. M. Landymore, Flag Officer Pacific Coast. The Japanese admiral exchanged calls on His Honour, G. R. Pearkes, VC, Lieutenant-Governor of British Columbia; Hon. W. A. C. Bennett, Premier of British Columbia; R. B. Wilson, Mayor of Victoria; and A. C. Wurtele, Reeve of Esquimalt.

Admiral Kuhara also attended special dinners at Government House, and at the admiral's residence in HMC Dockyard.

A guard and band from the Japanese ships, with a guard from HMCS *Naden*, participated in a wreath-laying ceremony at the Esquimalt Cenotaph, Esquimalt Road, on Wednesday, Aug. 26. Admiral Kuhara placed the wreath.

Nearly 200 Japanese personnel, including naval cadets, that afternoon visited the Canadian Services College, *Royal Roads*, for a tour of the military college and a tea. In the evening, officers of the visiting ships attended a Pacific Command reception in the wardroom of *Naden*.

Japanese and RCN softball teams competed in the early evening and at the same time, cadets from the Japanese ships were at the Empress Hotel attending a dinner, as guests of the city of Victoria. Later the cadets visited Butchart Gardens.

On Aug. 27 the Japanese naval band presented a concert in Beacon Hill Park.

Approximately 200 of the Japanese sailors toured the Fleet School at *Naden* on Friday morning and later visited the Legislative Buildings. Rear-Admiral Kuhara that same morning paid an informal visit to *Royal Roads*.

Enlisted personnel of the Japanese ships participated in several tours and sports events during their visit and attended smokers in the Fleet Club of the *Naden* and the chief petty officers' messes.

The visiting ships were open to the public in HMC Dockyard on Saturday, Aug. 29 from 9 a.m. until noon. Some 400 persons attended an "at home" program on board the ships on Saturday afternoon.

During their stay the Japanese sailors saw a selection of films dealing with Canada.

The visiting ships sailed from Esquimalt on Sunday, Aug. 30, for Vancouver where they spent four days.

This marked the first time since 1958 that Japanese warships had visited the area. At that time, two Japanese frigates visited the Pacific Command of the RCN in connection with British Columbia's centennial celebrations.

Arrangements for the visit of the Japanese squadron were made under the direction of Lt.-Cdr. Ward Palmer, officer-in-charge of the RCN's operational diving establishment at Esquimalt.

At Esquimalt, in connection with the ship's visit, was Captain Kiyohide Seki, of the Japanese Maritime Self-Defence Force, defence attaché in Washington, D.C.

Assisting with language problems were four officers of the Royal Canadian Navy, all of whom speak Japanese fluently. They are Lt. James Tateishi, Lt.-Cdr. Gus Higuchi, and Cd. Off. Kenneth Koyama—all of Japanese extraction—Lt. Julien Rangel, who was born in Yokohama and is now serving in the Montreal area. Lt. Tateishi serves with HMCS *Shearwater*, Halifax. Lt.-Cdr. Higuchi and Cd. Off. Koyama are both from Toronto.



A reception in the Naden wardroom was one of the social events arranged during the visit of four ships of the Japanese Maritime Self-Defence Force Second Training Squadron to Esquimalt. From left to right are the Japanese consul-general, Mr. Noboru Imajo and Mrs. Imajo, Rear-Admiral Kamustoshi Kuhara, commander of the visiting squadron, Mrs. W. M. Landymore and Rear-Admiral W. M. Landymore, Flag Officer Pacific Coast. (E-77915)



Four destroyer escorts of the Japanese Maritime Self-Defence Force paid a visit to the RCN's west coast port at Esquimalt, August 26-30, carrying more than 1,200 Japanese naval personnel on a training cruise to North American waters. Two of the ships are shown arriving at the Esquimalt naval base, marking the first time Japanese military vessels have been in the area since 1958. (E-77925)

HAIDA, INC.

By

Lt Peter Ward, RCNR

Military Editor,

The Telegram, Toronto

WHEN the Royal Canadian Navy announced last year that HMCS *Haida*, Canada's most famous warship, was to be retired from the service, a group of sentimental Toronto men started a campaign to save her from the scrap heap.

Nearly 12 months later, the *Haida* is out of the Navy, but far from out of service. She's secured at the foot of York Street in Toronto, getting ready to start her new career as a medium for passing on a love of the Navy to all who care to visit her.

The months between the first formal meeting of those sentimentalists in Toronto who finally saved the *Haida* and the ship's eventual arrival at Pier Six in the Queen City on Aug. 25 were filled with heartbreak, elation, hard work, and humour.

The man who organized *Haida, Inc.*—as the ship's new owners are called—is Bruce Neil. Neil is an Air Canada captain, who had never been on board anything bigger than Toronto's Island ferry before last summer.

Neil's brother, Ron, who once served on board HMCS *Iroquois*, is now a sea cadet officer. He arranged for Neil to accompany him last summer for a short cruise in the *Haida* during the ship's last days as an RCN ship. The *Haida* spent the summer of 1963 in the Great Lakes, training reservists, and taking students and cadets on school relations cruises.

Neil heard the story of the *Haida's* past from her officers and fell in love with the ship. He became convinced she should be preserved. At the same time, several other men, Allan Howard, of Toronto's Marine Museum, Norman Simpson, a former naval officer turned lawyer, and I, were thinking similar thoughts. We were brought together by the officers of the *Haida* and the first meeting took place early last fall, in Allan Howard's Marine Museum. After preliminaries had been discussed, other men came into the picture. Bill Doole, editor and published of the *Brampton Times and Conservator*; Joe O'Sullivan, Goodyear Tire sales executive, Dave Kidd, another Toronto sales executive, Jack Graham, lawyer, Don Smith, of the Bell Telephone, and Rear-Admiral P. D. Budge, RCN (Ret), joined *Haida Inc.* Admiral Budge took a bit of convincing, but once he believed the project was possible, he threw all his determination behind saving the *Haida*.

Haida, Inc., became incorporated, through the gratis legal work of Jack Graham and Norm Simpson, as a non-profit corporation. Neil Bruce began a series of trips to and from Ottawa and Halifax to convince both government and Navy that the *Haida* project was possible. The ship moved out of commission and into Class C reserve late last year, and first word was that she would stay there for at least a year. That gave *Haida Inc.*, plenty of time to make their plans for the ship's future.



A candid photo of Vice-Admiral H. G. DeWolf, war-time captain of the *Haida* and former Chief of the Naval Staff, now retired and living in Ottawa. (O-15799)

Then, last winter when the Defence Department's economy drive began, it was announced that HMCS *Haida* would be declared surplus almost immediately and turned over to Crown Assets for disposal.

There was some frantic scurrying in the homes of the members of *Haida, Inc.* Neil Bruce doubled the frequency of his trips to Ottawa. Defence Minister Paul Hellyer was visited; so was the Chief of Naval Staff; so were the offices of Crown Assets. Finally the official word was handed down. The *Haida* would be sold to *Haida, Inc.* for \$20,000, delivered to Sorel, Que., in her Class C Reserve condition. She would be delivered Aug. 14. Bids from towing contractors applying to bring the *Haida* from Sorel to Toronto began coming in. Finally McAllister Towing Company, of Montreal, got the job for slightly more than \$6,000. McAllister said they were quoting a rock-bottom price, and said

Sharing the Cost of Preserving *Haida*

Funds are needed to help pay the cost of preserving HMCS *Haida* and donations will be greatly appreciated. Receipts for income tax deductions will be mailed to the donors. Gifts should be sent, along with the name and address of the donor, to *Haida, Inc.*, PO Box 668, Adelaide St. Post Office, Toronto 1. Cheques should be made payable to *Haida, Inc.*

The accompanying story tells of the efforts that went into saving the *Haida* from the cutting torches of the shipbreakers and her preservation as a memorial to the part played by Canada's sailors in the Battle of the Atlantic and the invasion of Europe.

An early issue of *The Crowsnest* will tell another story—that of her final journey under tow and under the tender care of a scratch crew of naval reservists from Sorel to her resting place in Toronto.

they, too, felt sentimental about the *Haida* . . . so sentimental, in fact, that they donated \$1,000 to *Haida, Inc.*

Paying the tow bill and insurance for the ship presented a real problem. None of us in *Haida, Inc.* are what you would call wealthy. Owning a Tribal class destroyer is a luxury we couldn't normally afford, so we approached the Toronto Dominion Bank with our story, and that's where the money came from.

Needless to say, the Navy, too, harbours sentimental feelings about the *Haida*. Once the ship's sale had been approved, the RCN pushed her delivery date back to Aug. 21. They had the *Haida* towed from Sidney, N.S., back to Halifax for a quick once over before

she began her new career. As much equipment as possible was put on board to make the job of turning the *Haida* into a memorial museum easier. Cases of Second World War gear were packed in the forward seamen's mess, to be used later in setting up displays.

Next came the problem of getting a crew to bring the *Haida* from Sorel to Toronto. Reservists from HMCS *York*, Toronto's naval division, volunteered to do the job, and the Commanding Officer Naval Divisions authorized three days' special duty for three officers and 12 hands. The reservists said they would pay for their own transportation to Sorel. The tow was scheduled to take three to four days.

The trip by rail to Montreal, then bus to Sorel, and finally back to Toronto via the Seaway at the end of a towing rope you'll find chronicled in a later issue. The saga should be titled: "The Perils of a Junior Public Relations Lieutenant as a Seaman", or "Sink, or Swim".

In any event, thanks to the kind services of HMCS *York*, and the expert towing ability of McAllister skippers, the *Haida* arrived at Pier Six in Toronto unscathed, if a little late.

She nosed into the jetty shortly after 1000 Aug. 25, the sun streaming down on her rust-streaked hull, and a cheering crowd waving hello from shore.

For the members of *Haida, Inc.*, the ship's arrival in Toronto, which for nearly a year had seemed the ultimate goal, signalled the beginning of a never-ending parade of problems. Money headed the list.

The new owners of *Haida* found themselves nearly \$30,000 in debt, with no prospects of earning funds until plenty more thousands of dollars had been spent getting the ship ready to receive her public.

The government had been generous in the terms of the destroyer's sale. The \$20,000 paid for the *Haida* was to be paid in 10 yearly instalments, the first one deferred a year from delivery date, and no interest to be charged. The terms couldn't have been more reasonable, and under the direction of senior naval officers, in both Ottawa and Halifax, the *Haida* had been stocked with stores which would make her eventual display to the public as easy as possible. Obviously *Haida, Inc.*'s project had the sympathy of both government and service officers.

The towing fee, a net amount of slightly more than \$5,000, had to be paid immediately. So did nearly \$2,500 to insure the HMCS *York* crew during their trip down the seaway, and insure the ship for the trip and her first year tied up in Toronto. Additionally, watchman services on board are required 24 hours a day while she is alongside in Toronto. All that comes to the healthy figure of \$256 a week. *Haida, Inc.*, has now hired CPO Jack MacDonald, who retired from the RCN Sept. 9 and started work on board the *Haida* the same day, to oversee the job of getting her in exhibition state. Jack is working for a salary that proves it wasn't the money that attracted him to the job.

So much for the money problems. *Haida, Inc.*, is running a campaign for funds this fall which, we hope, will assure the ship's future. You'll hear more of that later.

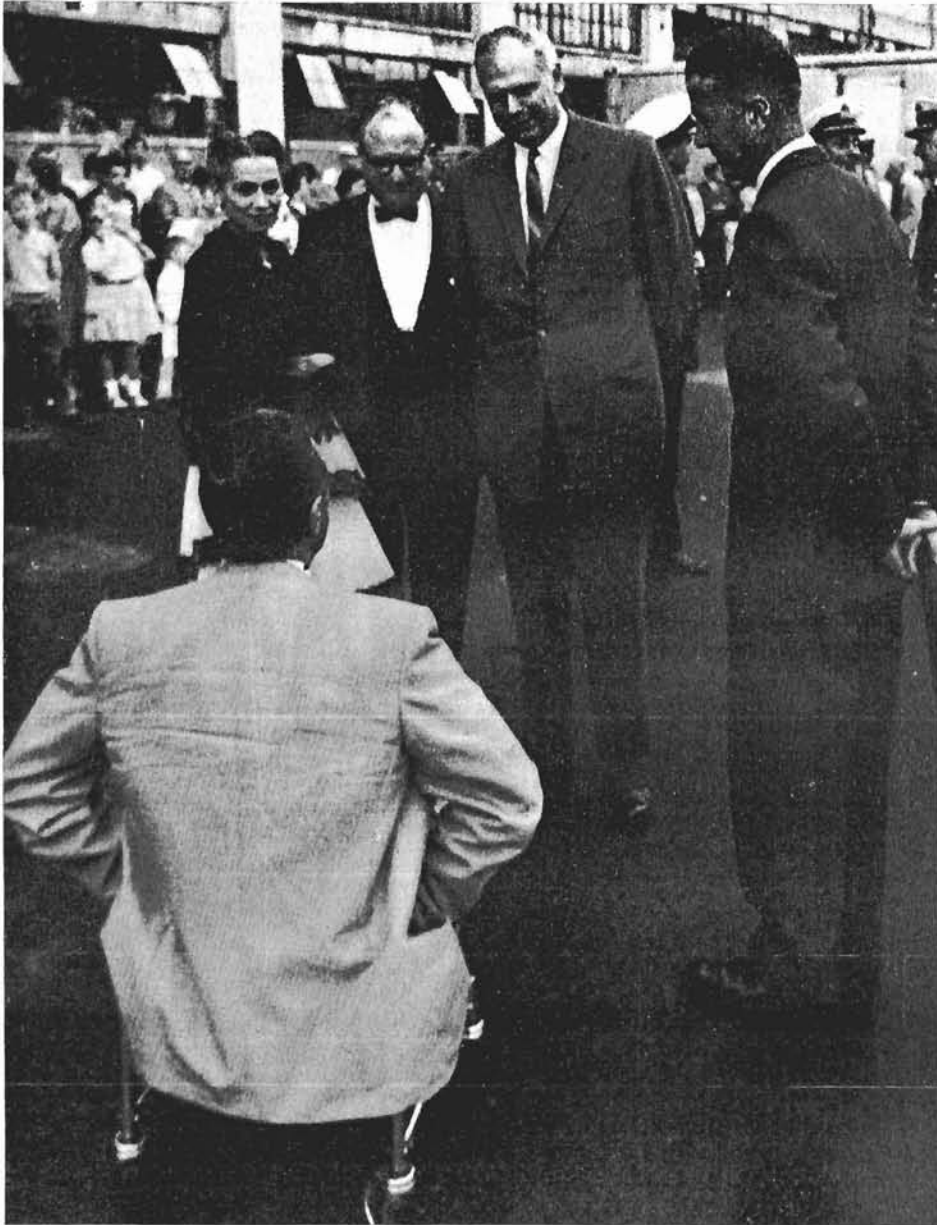

Defence Minister Paul Hellyer, pauses to chat with Alan Howard, a director of *Haida, Inc.* Mr. Hellyer was accompanied by His Worship, Mayor Phil Givens, and Mrs. Givens and, at left, Neil Bruce, president of *Haida, Inc.* (O-15800)

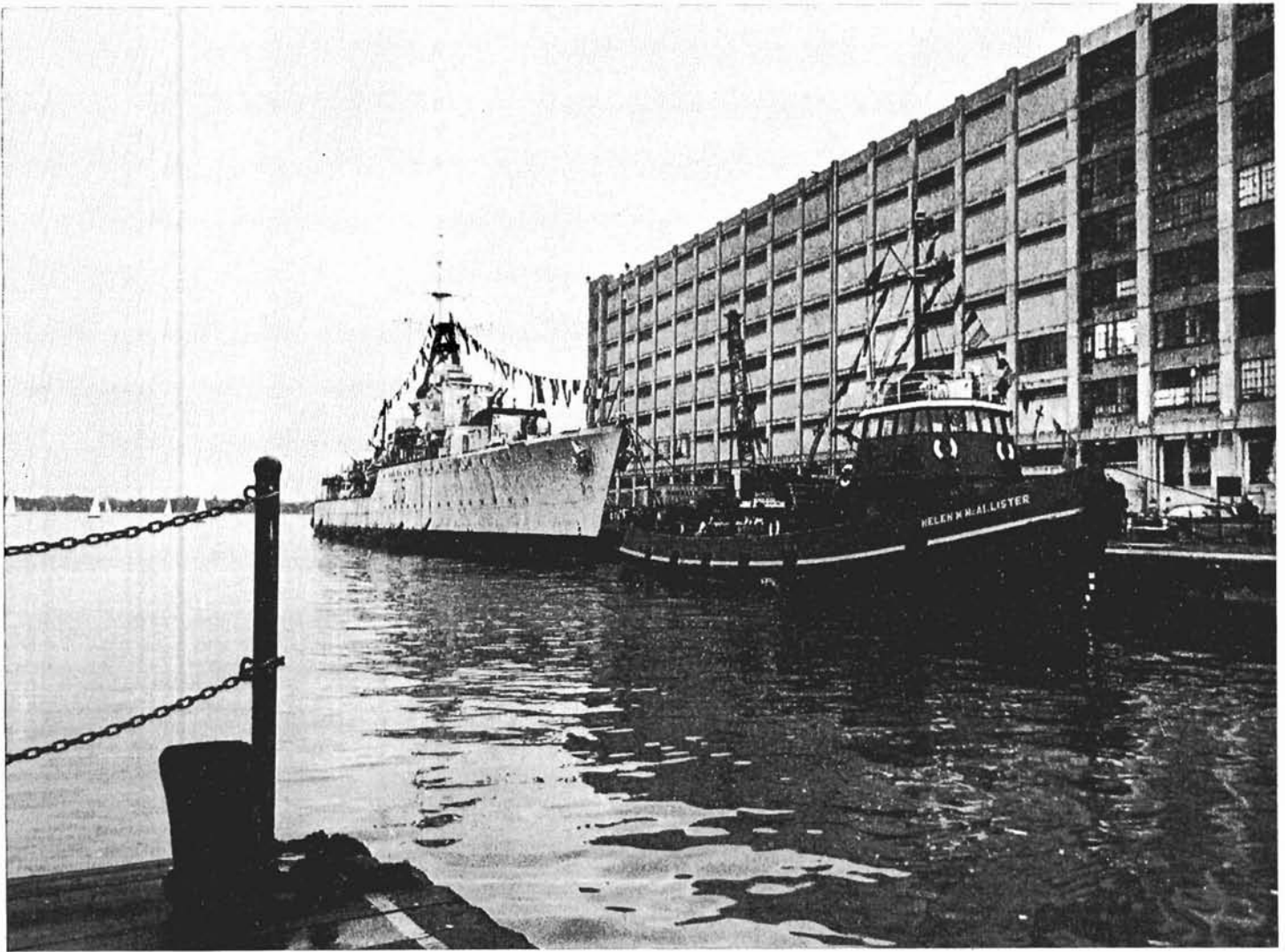

Journey's end at Toronto. The *Haida* under tow of the *Helen M. McAllister*. (O-15798)

Haida's first day in Toronto was a busy one. That evening Rear-Admiral R. P. Welland, Deputy Chief of Operational Readiness in the new integrated command structure, came to Toronto from Ottawa officially to start the *Haida* off in her new career.

With him came Defence Minister Paul T. Hellyer, who took time out from a well-earned holiday to say goodbye to the veteran destroyer. Rear-Admiral Welland is a former commanding officer of the *Haida*. Also attending the turnover ceremonies were retired Vice-Admiral H. G. DeWolf, a former Chief of Naval Staff who commanded the *Haida* and Commodore John Charles, the *Haida's* captain during her last Korean war tour. Toronto's Mayor Phil Givens, another enthusiastic fan of the *Haida's* was there too.

After a short session of speeches, Admiral Welland presented the ship with a White Ensign and a Blue Ensign. The

Haida is the first ship out of commission to be so honoured, and both flags will fly proudly when she's playing host to the public next year. Brief ceremonies alongside the *Haida* were followed by a reception in the wardroom of HMCS *York*, with some pretty salty tales about the *Haida's* past being exchanged among the ship's former captains.

That brings you up to date on what has happened to the *Haida* so far. Now we'll try to pass on some idea of what plans have been made for the ship's future.

During the fall and spring the *Haida* will be painted, cleaned up, and restored as closely as possible to her Second World War condition. There will be some discrepancies, but those can't be helped. She will, for example, still be fitted with 4-inch guns instead of the 4.7 she mounted when first built. The 3-inch-50 on the after canopy will remain, as will the squid mounts on

the quarter deck. The cost of altering her structure back to its original condition would be prohibitive.

When the water is high next spring and the day is right, with little wind and good visibility, tugs will take the *Haida* from Pier Six and tow her outside Toronto Harbour again. She will be taken to the west end of the Canadian National Exhibition Grounds, then gingerly squeezed through a gap in the breakwater. The ship will then be nursed back to the east end of the grounds, behind the breakwater, and nosed in to shore, her bows pointing north, just south of the eastern gates to the CNE. New fill has recently been dumped along the waterfront at this point, making an ideal spot for the *Haida's* final resting place. She'll be berthed on the edge of Coronation Park, a Metropolitan Toronto park dedicated to the memory of servicemen who fell during the Second World War. The city has informed *Haida, Inc.*, that all con-

cerned would be delighted to have the *Haida* there as part of that memorial.

When sufficient money has been raised, a concrete mole will be built along the water side of the *Haida*, to close her off from the lake. Water inside the mole will eventually be pumped out, then the area around the ship filled with concrete to leave her high and dry. Eventual cost of the project will eventually run to \$250,000.

Other retired naval personnel will be hired to work with Chief Jack MacDonald as permanent crew for the *Haida*. Probably as many as five or six will be needed to maintain the ship and guide visitors.

Haida, Inc. plans to charge a small fee for touring the ship, but the price will be reasonable. *Haida, Inc.*, is a non-profit company, so any funds collected must be put back into the ship. Admissions, we hope, will pay staff salaries and look after the up-keep, but that is all. Several ideas for money-making have been advanced, but *Haida, Inc.*, has decided that nothing will be sold on board the *Haida*. No refreshment bars or candy stalls will ever stand on those decks, and that's a point the directors insist upon.

It's possible there may be a refreshment stand built in the future on the jetty, beside the ship, but nothing commercial will ever touch the ship herself.

The firm intention of the directors of *Haida, Inc.*, is to make HMCS *Haida* into a fitting memorial of all sailors who served in the RCN. We hope that



Neil Bruce, the civilian flyer whose drive and enthusiasm led to the formation of *Haida, Inc.*, of which he is president, and to the rescue of the famous warship from the scrapheap. With him is Rear-Admiral R. P. Welland, a former *Haida* CO. (O-15803)

by showing the public how seamen lived on board ship, and how they fought their weapons, a greater appreciation of things naval will be passed on to thousands of Canadians. The *Haida* will become reminder of all the

little ships that made our Navy world-famous.

We of *Haida, Inc.*, do not consider ourselves the owners of this proud ship; we are merely custodians of her for the people of Canada.

VANCOUVER HOST TO MANY SHIPS

Three major events in Vancouver this past summer were successful, due in no small measure to the participation of the Royal Canadian Navy.

Captain J. C. Gray, Senior Naval Officer, Vancouver, and his staff busied themselves arranging participation of both RCN ships and personnel in Vancouver's Maritime Festival, the Pacific National Exhibition and the formal visit of a training squadron of four destroyers from the Japanese Maritime Self Defence Force.

Joining the *Qu'Appelle*, *Fraser*, *Margaree* and *Mackenzie* of the Second Canadian Escort Squadron, under Captain Jack Pickford, were four American ships to make what civic authorities declared to be the most successful Vancouver Maritime Festival yet. The U.S. naval vessels were the guided missile cruiser *Galveston*, the guided missile destroyer *Henry B. Wilson*, the assault ship *Vancouver* and the conventional

submarine, *USS Tang*. The ships were part of the USN's Pacific Training Task Force and were under the command of Rear-Admiral Lot Ensey, Commander, Cruiser Destroyer Flotilla 9.

During the festival, CBC and CTV television featured several coast-to-coast shows built around the visiting ships. One, CBC's "Vacation Time", spent almost an hour on board HMCS *Qu'Appelle*, interviewing Captain Pickford and Cdr. Alex Kilpatrick, her captain, as well as members of the ship's company. All units landed marching parties to take part in a large parade.

The *Qu'Appelle* and *Saskatchewan* were in Vancouver for the opening of the Pacific National Exhibition. Ships and establishments of the Pacific Command provided a 50-man guard and the band from HMCS *Naden* for the two-mile-long PNE Parade. The guard and band, trained by Lt. John Rafter, from *Naden*, performed the Sunset Ceremony nightly as a feature of the PNE's grandstand show in Empire Stadium. The

guard was commanded by Lt. Walter Brain and Sub-Lt. Michael Muirhead, with the band under Lt. Tudor Jones and the 12-pounder guns' crews under Cd. Off. Robert Clitheroe.

A round of entertainment was provided for 1,200 officers and men of the Japanese Self Defence Force when four ships of Maritime Command visited Vancouver. They were the destroyers *Ariake*, *Yugure* (both of which were former USN ships), *Teruzuki* and *Makinami*.

The ships were part of the Japanese Training Squadron under command of Rear-Admiral Kazutoshi Kuhara. Appointed to the ships as interpreters were the following RCN and RCNR officers: Lt.-Cdr. A. Higuchi, Lts. J. Tateishi and J. R. Rangel, and Cd. Off. (MT) K. Koyama.

In addition, on an average of about once every week, Captain Gray's staff arranged visits for USN destroyers and submarines and Coast Guard vessels in port for leave during training cruises.

OFFICERS AND MEN

Mobile Canteen For Dockyard

Vice-Admiral Harry G. DeWolf, RCN (Ret), former Chief of the Naval Staff and president of the Royal Canadian Naval Benevolent Fund, presented a fleet mobile canteen to the RCN's Atlantic Command at a ceremony Aug. 7 in HMC Dockyard, Halifax.

Admiral DeWolf, on behalf of the Benevolent Fund, presented the canteen to Commodore R. L. Hennessy, Commodore Personnel Atlantic Coast, who accepted the vehicle for Rear-Admiral Jeffrey V. Brock, Flag Officer Atlantic Coast. Admiral DeWolf was accompanied by Cdr. Bruce Oland, chairman of the Eastern Claims Committee of the Fund.

There long has been a requirement for a mobile canteen to provide snacks to naval personnel of ships in harbour during the evenings when galleys shut down.

At the annual meeting of the RCN Benevolent Fund in May, it was decided to donate a fully-equipped canteen vehicle to the Atlantic Command. In presenting this gift, the Benevolent Fund went beyond its traditional role of providing loans and grants to individual people in need. During the 15-month period ending March 31, 1954, the fund assisted 700 persons with grants and loans amounting to more than \$200,000.

Considerable behind-the-scenes work was done to prepare the vehicle for its role. On their own time, personnel of the Supply Department in HMCS

Weddings

Able Seaman Anthony Azzopardi, *Chaudiere*, to Mary Mildred Eleanor Hopkins, of Sackville, N.S.

Petty Officer N. I. Bessem, *Stadacona*, to Wren Janet Hansen, *Shelburne*, at Winnipeg.

Able Seaman Richard Buelow, *Chaudiere*, to Janice Irene Salsman, of Clementsport, N.S.

Able Seaman Lawrence Pye, *Chaudiere*, to Donna Marie Cox, of Halifax.

Able Seaman Robert Scobie, *Chaudiere*, to Wren Marlene Williams, *Shelburne* and Metcalfe, Ont.

Lieutenant Robert Montagu Scott, *Naden*, to Sharron Crofton, Salt Spring Island, B.C.

Ordinary Seaman David Tripp, *Chaudiere*, to Susan Knight Simpson, of Halifax.

Petty Officer Ronald Richard Vallillee, *Shearwater*, to Leading Wren Dorothy Ann Eldridge, *Shearwater* and Norwood, N.S.

Able Seaman Joseph Walsh, *Chaudiere*, to Jennie Theresa Inness, of Liverpool, N.S.



LDG. SEA. R. G. BOYDEN



LDG. SEA R. A. SCHAVER

Ldg. Sea. Richard G. Boyden and Ldg. Sea. Ralph A. Schaver tied for first place as top graduates from an engineering technician course. They were among a class of 20 men who recently completed a 43-week course in the RCN's Pacific Command Fleet School in Esquimalt. (E-77804; 1E-77805)

Stadacona refurbished the vehicle and men of the Engineering Division of the Fleet School installed hot food equipment and made other modifications to the canteen.

Battle of Atlantic TV Drama Theme

An heroic chapter in Canada's naval history forms the background for *Convoy*, a serialized drama being done on CBC-TV.

Convoy recalls the Battle of the Atlantic, when Hitler's U-boats roamed the seas spreading death and destruction, threatening the whole Allied war effort. It tells the story of one little ship that stood against the subs to get the precious convoys through.

Written by Joseph Schull, official historian of the RCN in the Second World War, and produced by Battle of the Atlantic veteran Ronald Weyman, the five-episode drama was to be presented Thursdays at 8:30 p.m. (Eastern time) starting October 1 on CBC-TV.

Sea Cadet Wins Scholarship

Sea Cadet Gerald Hastings of Nanaimo, B.C., became the first winner recently of the Navy League's Cdr. K. E. Grant Memorial Scholarship of \$300 and then was unable to retain it because he was accepted for training under the Regular Officer Training Plan.

Officer Cadet Hastings is a student at the University of British Columbia, where he intends to major in commerce.

Although he will not receive the cash grant which accompanies the award, he will be listed as the first sea cadet to win the scholarship, which was established in memory of the late Cdr. Kenneth E. Grant, RCN, who at the time of his death was Staff Officer (Sea Cadets) to the Commanding Officer Naval Divisions.

Cdr. Grant was killed in the Montreal air crash last November that took 118 lives.

Cdr. Pickersgill Dies, Aged 63

Cdr. Norman L. Pickersgill, VRD, RCNR (Ret), 63, died suddenly at his home in Ottawa September 15. Funeral

Births

To Able Seaman Robert D. Crocker, *Scotian*, and Mrs. Crocker, a son.

To Able Seaman Douglas Harrison, *Shelburne*, and Mrs. Harrison, a daughter.

To Lieutenant David M. Robinson, *Chaudiere*, and Mrs. Robinson, a son.

To Leading Seaman David Skelton, *Shelburne*, and Mrs. Skelton (the former Wren Lois Fraser), a daughter.

To Petty Officer William Turcotte, *Shelburne*, and Mrs. Turcotte, a daughter.

To Lieutenant-Commander Benjamin M. Weber, *Scotian*, and Mrs. Weber, a daughter.

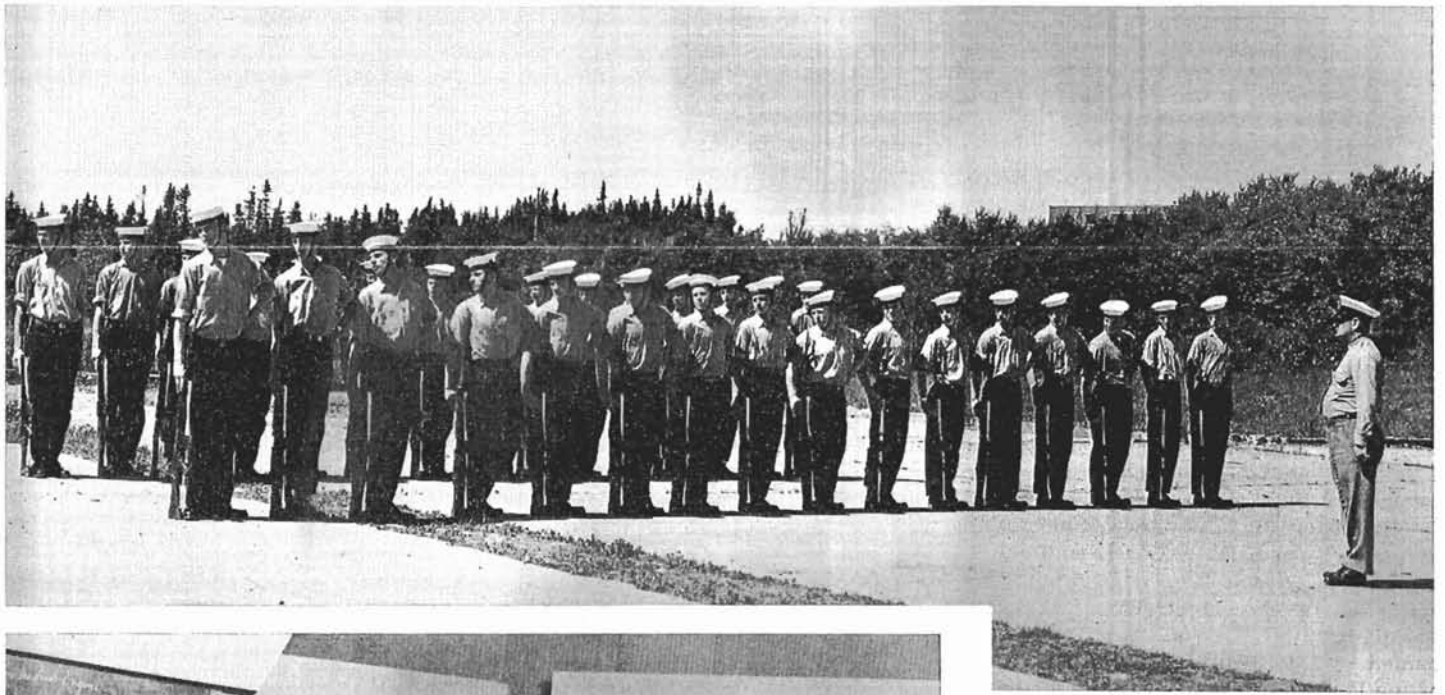

Thirty-five sea cadets took an aero-engine course at Shearwater during the summer. While their main purpose was to study the theory and maintenance of aircraft engines, as in accompanying classroom scene, there was time for sports, small-arms familiarization and other naval subjects. They also (top photo) trained for their appearance as guard at ceremonial divisions. The instructors are CPO G. B. Broome (top) and CPO I. J. Benoy. (DNS-33925; DNS-33924)

services, followed by cremation, were held on Sept. 17.

Cdr. Pickersgill was a commissioner in the Canadian Pension Commission of the Department of Veterans Affairs at the time of his death and had been with the commission since the Second World War.

Cdr. Pickersgill served for more than 20 years' unbroken time in the RCNVR and commanded the Regina half company of the RCNVR. In 1940-42 he commanded patrol and anti-submarine warships in the Atlantic and Indian oceans.

Then he commanded *Stadacona II*, later commissioned as HMCS *Peregrine*, the former Y-Depot of the RCAF in northern Halifax. The Canadian Army has its Windsor Barracks there now.

Sea Cadets Study Aircraft Engines

Tools and textbooks took the place of baseball, picnics and plain loafing for more than 30 youngsters who underwent summer training at HMCS *Shearwater*.

Thirty-five sea cadets, from across

Canada, have finished a seven-week course at the Naval Air Station, *Shearwater*. The cadets, ranging from 16 to 18 years arrived in early July from their Royal Canadian Sea Cadet Corps. With over 100 hours of class-room instruction in aero-engines, a lot of it on CS2F Tracker engines, the cadets left *Shearwater* with considerable experience in aviation mechanics.

Their training at *Shearwater* was not all in aircraft engines but branched out to include other naval fields. The theory of flight and gunnery were taught and small arms familiarization was given them at the firing range on McNab's Island. They were instructed in the firing of the Belgian-made FN rifle, the Sten sub-machine gun and the Browning 9mm. automatic pistol.

In addition to class-room instruction, they held sports periods twice weekly during which they used the extensive facilities at the *Shearwater* gymnasium and pool.

Towards the end of their training they took a two-day survival course at *Shearwater's* survival training area at Whitney Lake. This two-day course closely simulated the conditions under which they would live if they had to ditch an aircraft in heavy bushland. They learned to live off the land, building their own shelters from parachute materials and foraging for food.

The cadets were guided through the seven-week course by Lt. T. E. Giannou, RCN, Assistant Area Sea Cadet Officer for Newfoundland, and Lt. Steve May, RCSCC, a school teacher in civilian life.

Parade training and flying were also included in the Sea Cadet program during their stay and the sea cadet contingent formed the guard of honour at one of the ceremonial divisions held at *Shearwater* in August.

Over the last three years, 62 per cent of the cadets taking this course at *Shearwater* have joined one of the three services. Of the group enlisting, the majority have chosen the Royal Canadian Navy and have specialized in naval aviation.

Cdr. Carle Takes Command of Fraser

Cdr. Richard Carle has been appointed in command of the destroyer escort *Fraser*, a unit of the Second Canadian Escort Squadron, based at Esquimalt.

Cdr. Carle was born in the International Settlement, Shanghai, China, in September 1926 and moved to Victoria

in May 1936. He entered the RCN as a cadet at the former Royal Canadian Naval College, *Royal Roads*, in September 1943.

A gunnery specialist, he took a number of courses with the Royal Navy, and later served in the cruiser HMCS *Ontario* and the ocean escort HMCS *Antigonish*. He has served as commanding officer of the minesweeper HMCS *Chaleur*.

His most recent appointment was on the staff of the Director of Naval Fighting Requirements, at Naval Headquarters, Ottawa.

'COPTER SUPPORT SHIP READIED

The Royal Navy's first helicopter support ship, HMS *Lofoten*, was commissioned at Devonport on June 23. She is commanded by Lt.-Cdr. P. J. Morton, R.N., and will join the Home Fleet. She

has been converted from a landing ship, having been first commissioned in 1945.

The helicopters to be carried by HMS *Lofoten* will have considerable range and the ship will therefore be an important forward base. She will also be a valuable trials ship, for lessons learned in her operation will undoubtedly prove useful in the projected conversion of the Tiger class cruisers as helicopter carriers.—*Naval News Summary*

Dreadnought Visits Norfolk

The Royal Navy's first nuclear-powered submarine, HMS *Dreadnought* (Cdr. B. F. P. Samborne, R.N.), recently visited the United States. She was at Norfolk, Virginia, between June 19 and 24, and later paid a brief call at Bermuda.

It was the submarine's first visit to a port outside British territory since she was first commissioned in April 1963.

PLUMBER'S HELPER



THE CAPTION of the accompanying picture practically got up on its hind legs and begged for permission to write itself:

"Plumber's Helper Totes Plumber's Helper".

The animate helper in this case is Suzie, 10-year-old black Labrador belonging to Frank Phipps, of Esquimalt, a civilian plumber at HMCS *Naden*.

Any working day Suzie can be seen on the job around the naval establishment helping her master carry the tools of his trade. Usually, as in the picture, she settles on a sink plunger, commonly known as a plumber's helper, because it's more comfortable to carry than a pipe wrench.

She took up employment at *Naden* after the Phipps family noticed she was putting on weight and started making insulting remarks about her figure.

"If that's the way you feel about it," woofed Suzie, "I'll go to work."

She was as good as her word, but as a slimming project her job was a dead loss. There are 10 men in the maintenance shop at *Naden*, most of whom pack their lunches and make a point of sharing them with Suzie. This sometimes results in her becoming so drowsy that she knocks off work for the afternoon, seeks out a quiet spot for a siesta and doesn't show up until quitting time.

A born retriever, Suzie loves her work and has enjoyed carrying the tools since she was a pup. She also loved to gather up neighbour's newspapers, rubbers and overshoes and lug them home. This did not endear her to the neighbours. They are glad she has become a career girl.

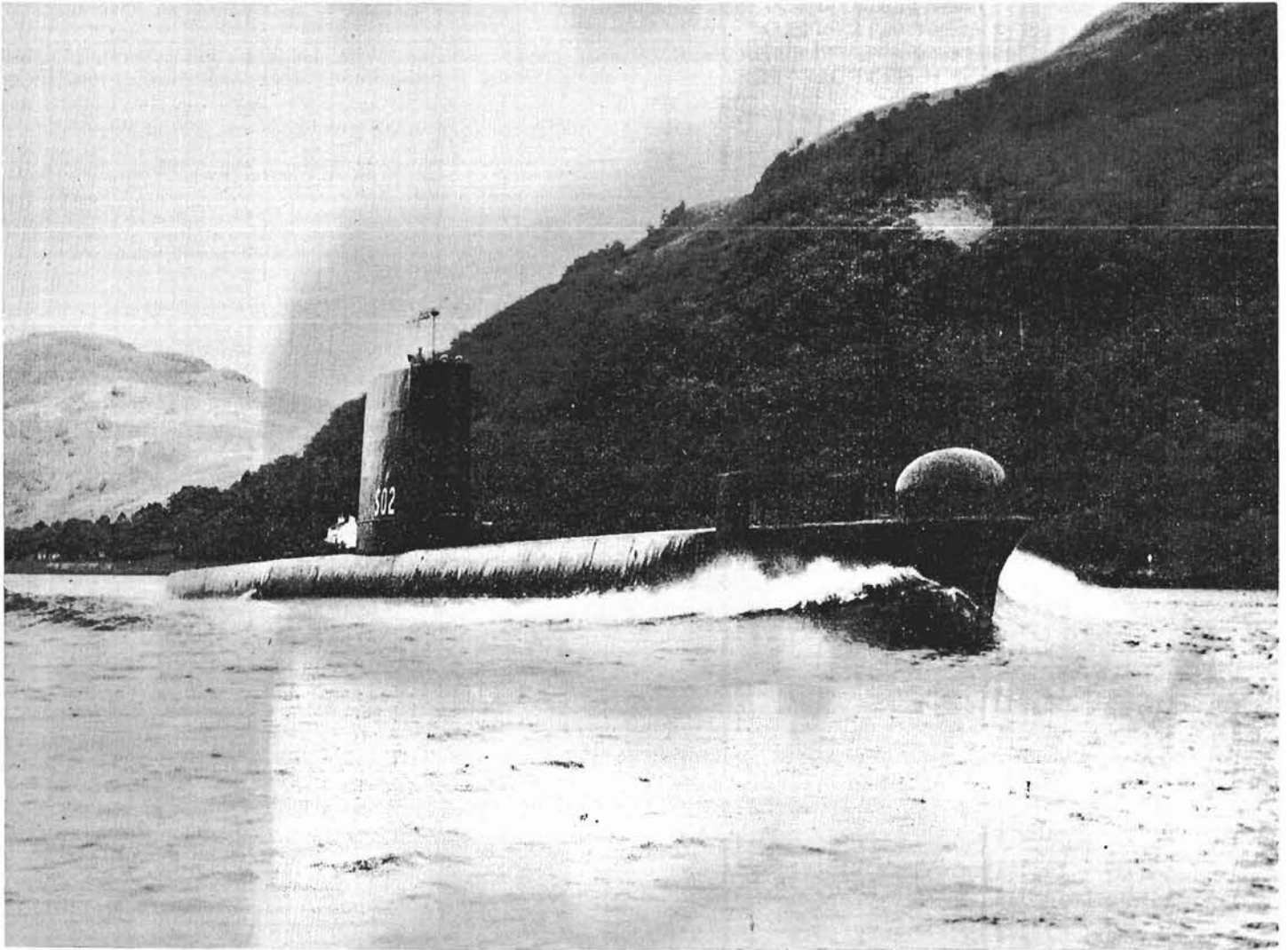

HMS Rorqual, pictured above, is one of eight Porpoise class submarines in service in the Royal Navy. She is commanded by Lt.-Cdr. Samuel G. Tomlinson, RCN, who has five other Canadians serving under him. At lower left, Lt.-Cdr. Tomlinson inspects a hydroplane hinge-pin held by PO Vernon M. Frankton, RCN; centre, Ldg. Sea Robert Nichol, RCN, is shown at the helmsman's position and, right, the captain dictates a message to radioman Ldg. Sea. Robert Davidson, RCN. (Top Photo from Royal Navy; EKS-1536; PL-144145; PL-144150)

RN SUB - RCN CAPTAIN

THE COMMANDING OFFICER of HMS *Rorqual*, a Porpoise class submarine based at Gosport, England, is a 36-year-old Canadian who began his service career as a boy soldier.

He is Lt.-Cdr. Samuel G. (Tommy) Tomlinson, RCN, a prairie-raised officer who has packed a wide variety of experience into just under 20 years in uniform.

Lt.-Cdr. Tomlinson entered the Canadian Army in October 1944, at the age of 17. He took airborne training but had not completed it when he was demobilized a year later. In November 1945, he entered the RCN as an ordinary seaman and subsequently served in the aircraft carrier *Warrior*, cruiser *Ontario* and destroyer *Cayuga*. He was serving as a petty officer on loan to the Royal Navy at HMS *Kestrel*, naval air station in Hampshire, when he was awarded his commission in January 1951.

After courses and training in Britain, Lt.-Cdr. Tomlinson returned to Canada in 1953 and joined the coastal escort, HMCS *Portage*. This was followed by a term as a Schools Relations Officer for Northern Ontario and part of Quebec; then it was back to Britain in March 1955 for submarine training with the Royal Navy.

In November 1955, he was appointed executive officer of HMS *Artful*, an "A" class submarine. In December 1958, he got his first command, HMS *Trespasser*, then the oldest operational submarine in the RN.

Returning to Canada early in 1960, he served for a year-and-a-half in surface ships, first the destroyer escort *Assiniboine*, then as executive officer of the frigate *Antigonish*. He was appointed back to Britain in August 1961 and a month later took command of HMS *Rorqual*.

The *Rorqual*, launched in 1956 and completed in 1958, is an operational unit of the Royal Navy's First Submarine Squadron. She and other submarines of her class are fore-runners of the Oberon class, of which three are to be built in Britain for the Royal Canadian Navy.

All told, 10 officers and 135 men of the RCN are taking submarine training in Britain or serving in RN submarines.

In the *Rorqual*, besides her captain, are five Canadian seamen.

Lt.-Cdr. Tomlinson is the son of Mr. and Mrs. S. A. Tomlinson, Calgary. His wife is the former Ann Landreth Lawrence, of North Battleford, Sask.

"Tommy" was born in Sioux Lookout, Ont., and was educated at Fort McMurray, Alta., Winnipeg and Lac du Bonnet, Man.

Puzzle Picture

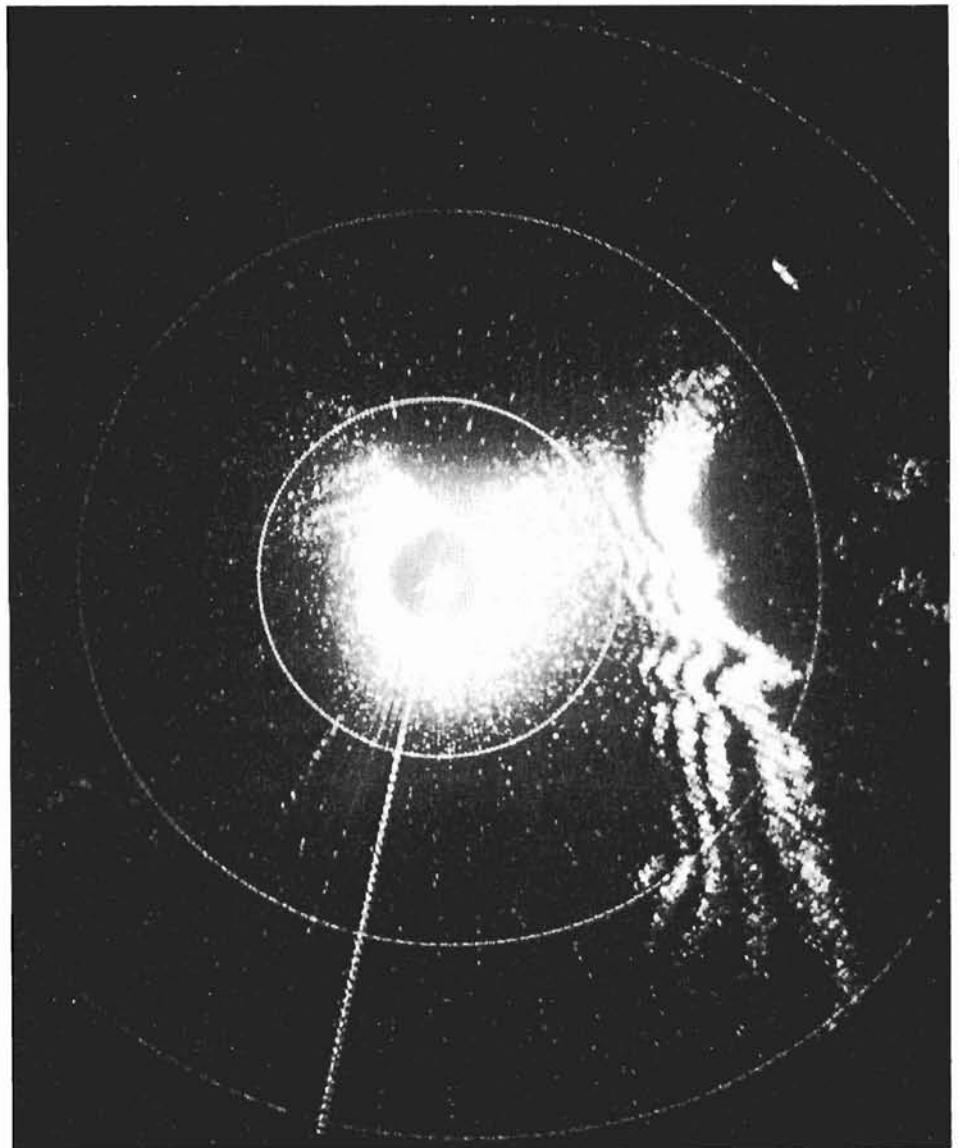

Don't try to guess what this is, because the chances are you'd be guessing come Christmas. The strange image on the *Bonaventure's* radar is, believe it or not, that of a sandstorm at sea, experienced off the Libyan coast when the carrier was on her way to Cyprus with Canadian soldiers and supplies. Although sand and dust drifted down over the *Bonaventure*, the main storm shifted course when it was within 10 miles of the ship.



NABOB REUNION

A CANADIAN-MANNED warship's valiant struggle for survival was recalled when a 15,000-ton freighter of German registry entered British Columbia waters in mid-August. She is SS *Nabob*.

The aircraft carrier *Nabob*, steaming the Norwegian Sea, was sorely wounded by a torpedo from a German U-Boat on Aug. 22, 1944. Today she is a cargo liner of the North German Lloyd Line, sailing between the west coast of North America and Europe. (See March 1956 *Crowsnest*.)

Built in a Seattle shipyard as an escort aircraft carrier, the *Nabob* was commissioned into the Royal Navy in Vancouver in 1943 and manned by a Canadian ship's company, later joined by an RN aircrew. Most of those Canadians were serving in HMS *Nabob* when she was torpedoed off Tromso, Norway, during strikes against the German battleship *Tirpitz*. Twenty-one men died in the torpedoing and six were injured.

The crew managed to keep the *Nabob* from sinking, despite a 40- by 50-foot tear in the starboard side. The stern sank 18 feet and a sharp list to starboard developed. To add to the hazardous situation, the *Nabob* had 200,000 gallons of aviation fuel in her forward tanks.

However, the carrier pointed her bows toward Scapa Flow and held a slow but steady course for home. She took five days to cover the 1,400 miles.

Another German submarine was sighted on the return trip and two of the *Nabob's* 20 planes were sent up to give chase. The U-boat disappeared and failed to attack.

On Oct. 10, 1944, the *Nabob*, acquired by the RN from the USN under lend-lease, was paid off. She was sold in March 1947 as scrap to a Dutch firm.

The German shipping firm, Lloyd, had the *Nabob* rebuilt as a freighter and installed new propulsion machinery. In deference to her war-time experience, they retained the name *Nabob*.

To mark the 20th anniversary of the torpedoing, the German first was host to approximately 40 ex-members of the ship's war-time company in Vancouver. By coincidence, the *Nabob's* present master, Captain Karl Kuhlig, was serving in a German warship just 50 miles away from the site of the torpedoing that late August afternoon 20 years ago.

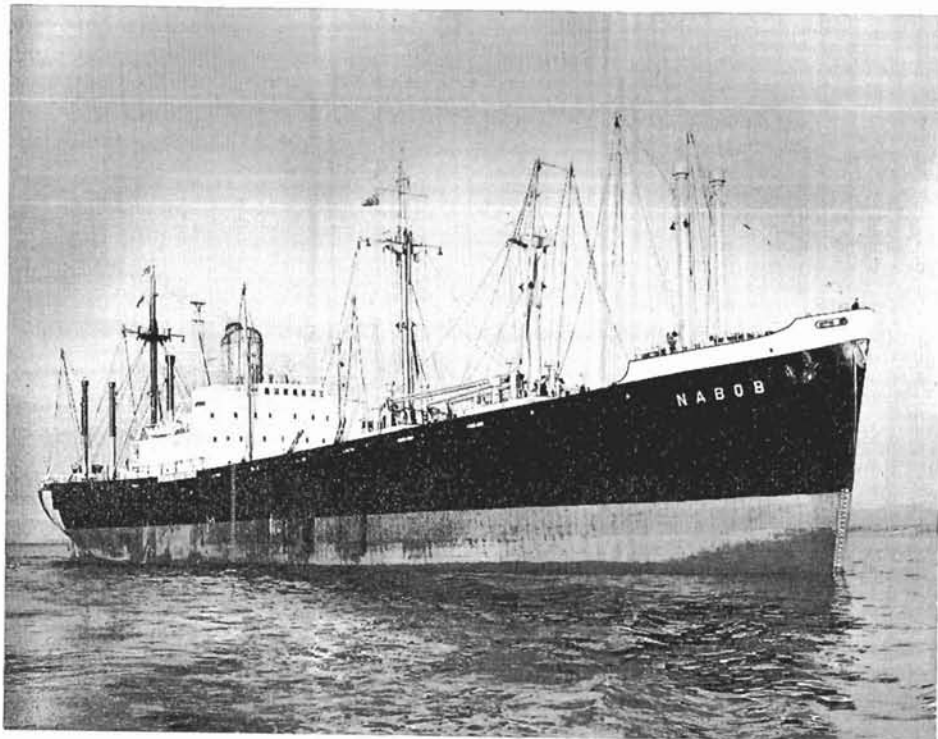

Forty former officers and men of the Second World War aircraft carrier *Nabob* were guests at a reception given in Vancouver on August 15 by the owners of SS *Nabob*—the same ship that was torpedoed off northern Norway 20 years earlier. The *Nabob* now carries cargo between the west coast of North America and Europe. The top picture is of the *Nabob* as she appears today and the bottom picture is of those attending the reception. (E-77781; E-77833)

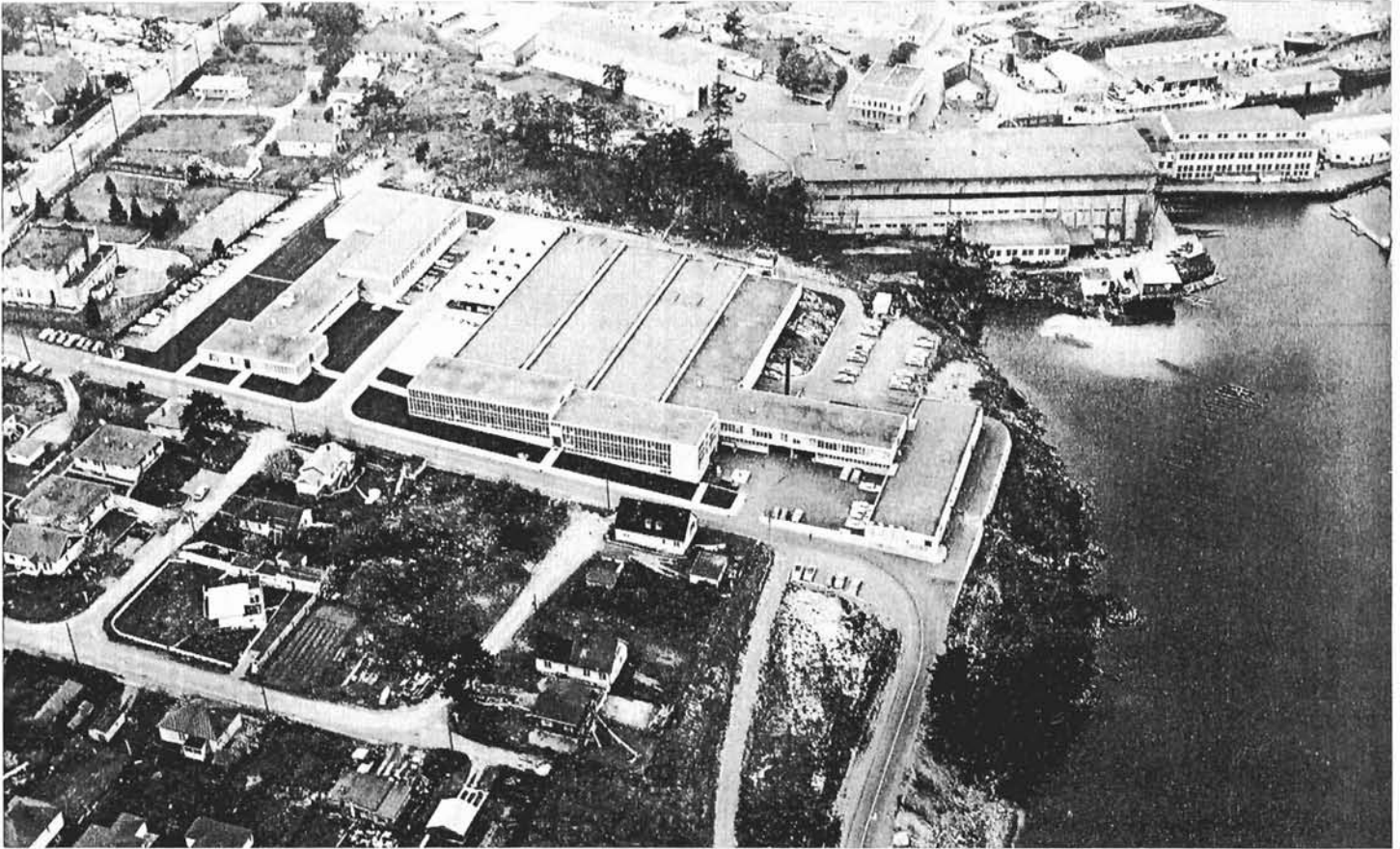

The Engineering Division of the Fleet School at Naden is located at the head of Esquimalt Harbour, not far from Yarrows' shipyard. (E-60695)

APPRENTICE PLAN

THE NEED for qualified and competent tradesmen in the Royal Canadian Navy is a continuing one. The Technical Apprentice Training Plan is intended to help supply these badly needed men. Basically, the training function is two-fold; to train competent tradesmen and at the same time competent leaders.

The Technical Apprentices (APs) are accommodated in Nelles Block, HMCS *Naden*, the RCN's training establishment at Esquimalt. Instruction takes place in the Technical Apprentice Section of the Engineering Division, Fleet School. Other divisions of the *Naden* Fleet School give instructions in other aspects of training as required.

In April 1951 the Naval Board discussed the increasing difficulty of obtaining technical personnel for the service. It was decided to train tradesmen within the RCN and approval was given to establish an RCN trades school to be called the naval trades training

centre with an Apprenticeship Training Scheme. This scheme would provide apprentices with the trade qualifications normally obtained by the apprentice-trained civilian tradesman.

As part of long-term planning, a permanent establishment was to be located ashore. In the meantime, the

by

Lt. D. W. Wilson, RCN

former *Flamborough Head*, a 10,000-ton maintenance ship, was commissioned as HMCS *Cape Breton* and secured at HMC Dockyard, Halifax, to provide the apprentices with living, workshop and classroom accommodation.

An entry of 100 apprentices was proposed for the first year with a similar number planned for the following year. After new entry training at

HMCS *Cornwallis*, the men were to go to the training centre for two years to acquire basic trade skills. They were then to be selected for the branches for which they were needed or for which they showed aptitude. During the following two years, they would be given branch training in branch schools, at sea and in the Naval Trades Training Centre.

By May 1952 a concentrated recruiting program had been launched for boys between the ages of 16 and 19 years who had completed Grade X. Candidates underwent the normal recruiting process and the candidate was required to write a composite examination paper covering English, mathematics and general science (Grade X level). In addition, a mechanical aptitude test was administered. The selected eligible candidates were interviewed by a selection board under the chairmanship of an officer from the apprentice training staff.

In the fall of 1952 a directive was sent out of the Fleet indicating there was limited space in the scheme for men of any branch who could meet the requirements, providing he was prepared to transfer to the Apprentice Branch.

The length of the initial engagement for apprentices was to be seven years. Graduates were to be qualified to the trade group 3 level and to hold the rank of petty officer second class.

The first entry of 66 ordinary seamen apprentices (OSAPs) commenced training in the *Cape Breton* on February 2, 1953. This initial group was composed of five trades, engineering, shipwright, air, ordnance and electrical. The original figure of 100 entries a year had been reduced because of a combination of limited facilities available and a lack of response by qualified candidates to the recruiting drive. And so the plan progressed; 50 men entered the scheme in 1954 and 1955 as one single entry annually.

By the middle of 1955, it was seen that an annual entry of 50 apprentices would at times saturate the training spaces completely while at other times no difficulty would be encountered.

It was decided that a twice-a-year intake of not more than 30 would meet this condition and this plan was carried out in 1956 and 1957.

Long before the new Combined Technical Training Establishment—later called the Naval Technical School, and now the Engineering Division of the Fleet School—was completed at Esquimalt, plans had been made to transfer training ashore from the *Cape Breton*.

The apprentices were to have separate machine and fitting shops of their own, though it was planned to conduct training in allied trades (welding, etc.) in the CTTE shops. In addition, the trainees were to undergo branch specialist training in the respective specialist training facilities located in the CTTE, viz, engineering shipwright and ordnance. During such training, the apprentices were under the direct administration of the Staff Officer Apprentice Training Division. The electrical and air apprentices were to continue to receive branch specialist training in their respective schools on the East Coast but they also were to be administered by the same officer in *Naden*.

Arrangements were made for administration to come under the control of the Commodore, RCN Barracks, Esquimalt.

The new facilities at *Naden* were opened in 1958 and the first term for

apprentices in the new buildings commenced in July of that year.

By 1958 it had been decided that trades other than engineering and shipwright would not continue in the TATP (the last of the other trades joined in January, 1959, and graduating in April, 1962). Commencing with the latter half of 1958 and carrying on through 1960, the enrolment figures were increased. In 1960, the trade structure was reviewed and altered somewhat and it was decided to revert once more to single annual entries and to stabilize the numbers at 34. Also, future entries were to graduate as leading seamen rather than petty officers second class. Thus it remained until the summer of 1963.



In the Fleet School's boat shop. (E-66965)

In the fall of 1962, the syllabi for engineering and hull apprentices were revised and lesson outlines published. (The syllabi will be dealt with in a later section.)

The last entry to graduate as petty officers second class completed its training in April 1963.

The summer of 1963 saw several changes of policy concerning the TATP. The Apprentice Training Plan Review Committee met in April and as a result of these meetings, recommended in part the following:

- the Apprentice Training Plan be expanded to the maximum capacity of the Technical Apprentice Section, Engineering Division, Fleet School, HMCS *Naden* to assist in overcoming the shortage of ER and HT tradesmen;
- the annual input to apprentice training for ERs be increased to 83;

- the annual input to apprentice training for HTs be increased to 17;

- a bi-annual entry into the Technical Apprentice Section, Engineering Division, HMCS *Naden*, be instituted commencing in July, 1963, with a Fleet entry of 50, and in January, 1964, a civilian entry of 60. These intake figures should be subject to annual review;

- the apprentice entry from the Fleet be increased to 50 a year commencing July, 1963; the upper age limit raised to 21 years; and the existing marriage regulations remain unchanged.

These recommendations have been approved by the Naval Board and are in the process of being implemented.

To prevent too great a shortage of highly trained technicians, the RCN embarked upon the expanded apprentice program to supplement the output of technicians from the trade course in the two Fleet Schools. This is a convenient point at which the present TATP program may be reviewed.

The present requirements can be broken down most conveniently in terms of the two branches currently associated with the TATP.

The engineering technician (ER) must attain a trade standard as a machinist, since he is the major source for the trade requirements of "machinist sub-specialty". Previously, this level of skill was recruited as a direct entry petty officer on successful completion of a trade test. The Navy's new trade structure established in 1960 does not allow for the purely trade specialist, as all trades must now carry the military responsibilities of their rank. In addition, civilian-trained machinists are in short supply and are highly paid. Consequently the service could not attract any appreciable number.

There is insufficient training time or opportunity to produce highly skilled tradesmen from Fleet School trade group courses. It is possible for trade course men with outstanding aptitude to achieve this standard and these were candidates for the machinist sub-specialist courses which commenced in September 1963. Others not so well suited to machinist training all obtain sufficient shop experience to understand the principles of shopwork and repair operations and are thus fully capable of supervising these functions.

Thus there are two sources of the "machinist sub-specialty" and adequate numbers should be available as a result.

The *Hull Technician* (HT) must attain an acceptable standard in carpentry, platemwork, welding, sheet metal,



A high degree of precision is demanded of technical apprentices under training at the Fleet School in Naden. Two of them are shown at work on a project demanding delicate caliper measurements. (E-59018)

plumbing, blacksmithing, plastic repair, boat-building and painting. These trades were formerly recruited individually as direct-entry petty officers after successfully completing a trade test. The new trade structure and a requirement for efficient employment of manpower, does not allow for such a degree of specialization—obviously a destroyer escort could not carry a petty officer specialist for each of the trades mentioned above. No civilian trade incorporates such a diversity of skills and hull technicians must be trained with-in the service.

There is also an avenue for advancement of hull mechanics to hull technicians by means of Fleet School trade group courses. This complements the output of HTs from the TATP.

Recruiting methods have not altered appreciably since the first entry was recruited in 1952. A standard questionnaire for screening applicants has been developed by the Apprentice Training Section which consists of a fixed series of questions in each evaluation area, for example:

- Service motivation;
- Apprentice training motivation;
- Leadership potential;
- Appearance and bearing;
- Emotional stability;
- Social relations.

When used in conjunction with test scores, fairly accurate and consistent assessments of the candidates can be made.

Recruiting may be dealt with in two sections, Shore and Fleet entries.

Shore entries are processed at the end of a school year and the candidates passing preliminary screenings at the recruiting centres may be selected by Naval Headquarters to appear before the Apprentice Selection Board in July of each year. Those recommended by the board and approved by Naval Headquarters are enrolled as APs and sent to *Cornwallis* for new entry training. They commence apprentice training at *Naden* the following January.

The requirements for shore entries are as described earlier in this article.

Fleet entries are obtained from the Fleet and eligible candidates appear before selection boards held in *Stadacona* and *Naden* each summer. These

A Parting Gift

In a heart-warming gesture former crew members of the decommissioned fleet maintenance vessel *HMCS Cape Breton* distributed some \$2,400 of the ship's fund to half-a-dozen Greater Victoria charitable organizations.

The generosity of the ship's company in donating this money—all of which came out of its personal pocket—to local charities demonstrates the close links which have so happily been forged in Victoria between its residents and the personnel of the Royal Canadian Navy.

The community-at-large will long remember with gratitude the old *Cape Breton's* parting gift.—*The Daily Colonist*, Victoria.

men join the Apprentice Section, *Naden*, in July to commence training. Briefly, the requirements are as follows:

- (a) at least minimum scores in all tests taken by shore entries;
- (b) grade X education;
- (c) be less than 22 years of age;
- (d) agree not to marry until successful completion of the second year of training.

A six-month probationary term is spent at *Naden* and on successful completion of Term I, Fleet entries are re-classified APs and re-engaged for a total of 7 years from entry into the TATP. Future advancements and promotions will be subject to successful completion of training phases.

The course duration is 39 months, made up of six equal terms of 22 weeks and one final one of 15 weeks. The balance of the time is devoted to leave periods. Apprentices are allowed four weeks' leave plus travelling time in the summer and two weeks' special leave at Christmas.

The two main phases of the training may be broken down as follows:

- 1. common training—Term I—is common to all Apprentices;
- 2. specialist training—Terms II to VII inclusive—provide specialist training for Engineering and Hull Technicians:

ER Syllabus

Topic	Duration (Periods)	% Total time
1. Fitting and Machine Shop.....	2134	41
2. Allied Trades (Welding, etc.).....	252	5
3. Engineering, including		
(a) Theory of equipment		
(b) Bailey Meter controls		
(c) Refrigeration, etc.....	1023	20
4. Academics.....	450	9
5. Miscellaneous, including		
(a) Physical training		
(b) Rank training		
(c) NBCD		
(d) Padre etc.....	530	10
6. Practical Engineering (at sea)....	74	15
Total.....	5136	100

HT Syllabus

1. Fitting Shop (Term I).....	512	10
2. Hull Shops, including		
(a) Ship's Carpentry		
(b) Welding		
(c) Sheet Metal		
(d) Plumbing, etc.....	2148	42
3. Hull Theory, including		
(a) Draughting		
(b) Ship Construction		
(c) Administration		
(d) Docking		
(e) Cathodic Protection.....	775	16
4. Academics.....	360	5
5. Miscellaneous, including		
(a) Physical training.		
(b) Rank training		
(c) NBCD		
(d) Padre etc.....	596	12
6. Practical Engineering (at sea)....	744	15
Total.....	5106	100

Term V in its entirety is spent in a sea-going ship of the Esquimalt-based Second Canadian Escort Squadron to provide operating and minor maintenance experience.

During this term, the technical apprentice receives the training necessary to qualify for the Auxiliary Machinery Operator's Certificate.

The table below indicates the steps by which a man progresses from OSAPs and LSER3 to LSHT3.

	Promotion	Advancement
Entering <i>Naden</i> (Apprentice Section).....	OS	APS (ATS)
successful completion of Term I.....	OS	transfer to AP from other branch
successful completion of Term II.....	AB	AP1
successful completion of Term LV.....	AB	AP2
successful completion of Term V.....	LS	AP2
successful completion of Term VII.....	LS	TG3

Promotions also depend upon time in rank and exemplary conduct but the table above shows when the man will be qualified professionally.

After graduation, the ex-apprentice is transferred to his appropriate branch.

While the object of apprentice training is to provide the Fleet with fully trained tradesmen competent in the technical knowledge of their branch, it is also the object to be certain these men are well grounded in the elements of leadership. The majority of the 39-month period of training is devoted to trade training which leaves little time for leadership training.

In the *Cape Breton* the leadership was encouraged by giving the apprentice progressive responsibility until, in his senior term, he is taking charge of a duty watch.

After the transfer to *Naden*, the degree of responsibility that could be assumed by the senior apprentice was limited and the graduated apprentice lacked the opportunity to be as fully effective as a petty officer. To compensate at least partially for this, lectures on leadership and other rank requirements have been incorporated into the syllabi. It is considered that acceptable requirements for rank are being met in the 39-month course.

Of the 639 young men who have commenced training since 1953, 361 have graduated or are still under training.

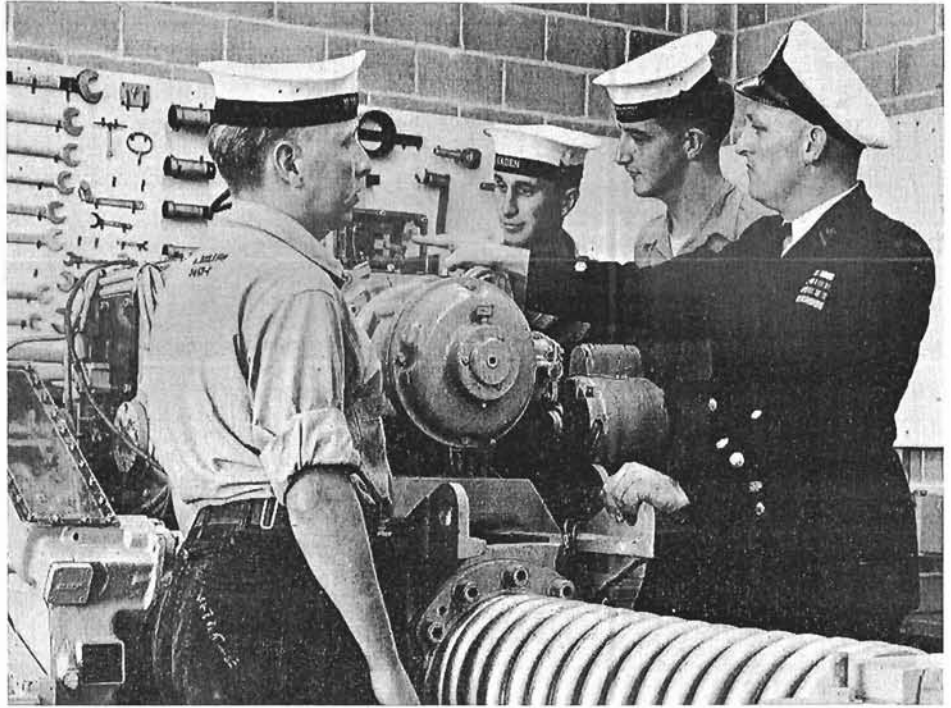

Three engineering apprentices lend attention to their chief petty officer instructor's explanation of some complicated naval machinery. (E-46942)

The 278 who have left the scheme have done so either by their own request or because they have failed to reach the required standard. The 278 wastage represents an overall wastage of 43.5 per cent. A wastage figure for entries still under training may only be estimated, but the figure usually quoted is 42 per cent.

It is anticipated that the percentage wastage figure will become less as a direct result of the introduction of improved methods of selection mentioned earlier. Early results from the January, 1963, entry bear this out.

In summary, the requirement for skilled Engineering and Hull Technicians can in part be met by the TATP. The object of the plan may be summarized as follows:

- to produce Engineering Technicians, trade group 3, with a machinist sub-specialty;
- to produce qualified Hull Technicians, trade group 3;
- to produce competent leaders;
- to provide eligible civilians and the more ambitious men of the Fleet with the opportunity to obtain a fine trade training with the

probability of accelerated advancement and promotion to the advantage of both themselves and the service.

Obviously, to achieve the aims and produce up to 83 engineering and 17 hull technicians needed annually requires an adequate response to recruiting. This is where the officers and more senior men in the RCN can help by making certain the younger men are aware of the opportunities offered by the TATP. It should be emphasized that the fleet transferees may come from any branch provided they meet the basic requirements, pass the tests and successfully complete the probationary first term in *Naden*.

The 39-month apprentice course is one which requires much in the way of effort from those under training. Because the course is so intensive, it is, in a sense, an endurance test—well within the capabilities of a person willing to work hard. Any man showing interest in advancing himself professionally by becoming an apprentice, will find a reward for his efforts in the form of accelerated advancements and promotions.



HERE AND THERE IN THE RCN



A young ensign of the Belgian Navy, Bernard L. Ravet has ended his training with the Royal Canadian Navy by winning his watchkeeping certificate. Ensign Ravet completed his training at sea on board the Canadian destroyer escort HMCS Athabaskan. Presenting the WK certificate is Cdr. Peter Hinton, captain of the Athabaskan. (CCCI-214)

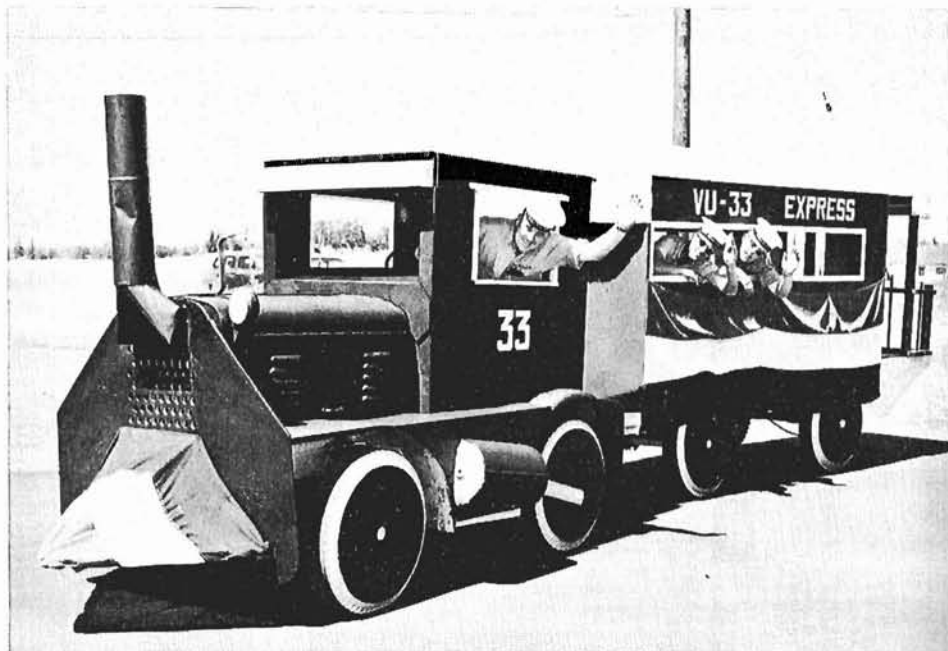

On the way to Dominion Day parade in Sidney, B.C., the children's "mule train" from VU-33, the RCN's air squadron at Patricia Bay, is given a trial run by "engineer" Ldg. Sea. R. K. Ireland and "club car passengers" Ldg. Sea. Kenneth Shaw and AB Fred Mann. (E-77247)



Douglas L. Pickell, 15, of Flin Flon, Man., is one of more than 1,000 Royal Canadian Sea Cadets to spend two-week summer training periods at HMCS Comox, sea cadet camp near Comox on the east coast of Vancouver Island. Instruction in knots and splices is being given by instructor Lt. Allan Hodgson, RCSC, of Winnipeg. Douglas is a member of Royal Canadian Sea Cadet Corps Husky and attends Hudson School. (E-77582)



PO Cadet Foster Sparks, of Cherry Brook, Dartmouth, speaks with Captain J. M. Paul, Commanding Officer, HMCS Cornwallis, during an inspection of the band of the Royal Canadian Sea Cadet Corps, undergoing summer training at the naval base. Right, is the bandmaster, Sub-Lt. B. T. Bevan, RCSC, of Bloomfield, Ont. In the background, is Ldg. Cadet Patrick Boudreau, of Sydney, N.S. (DB-19164)

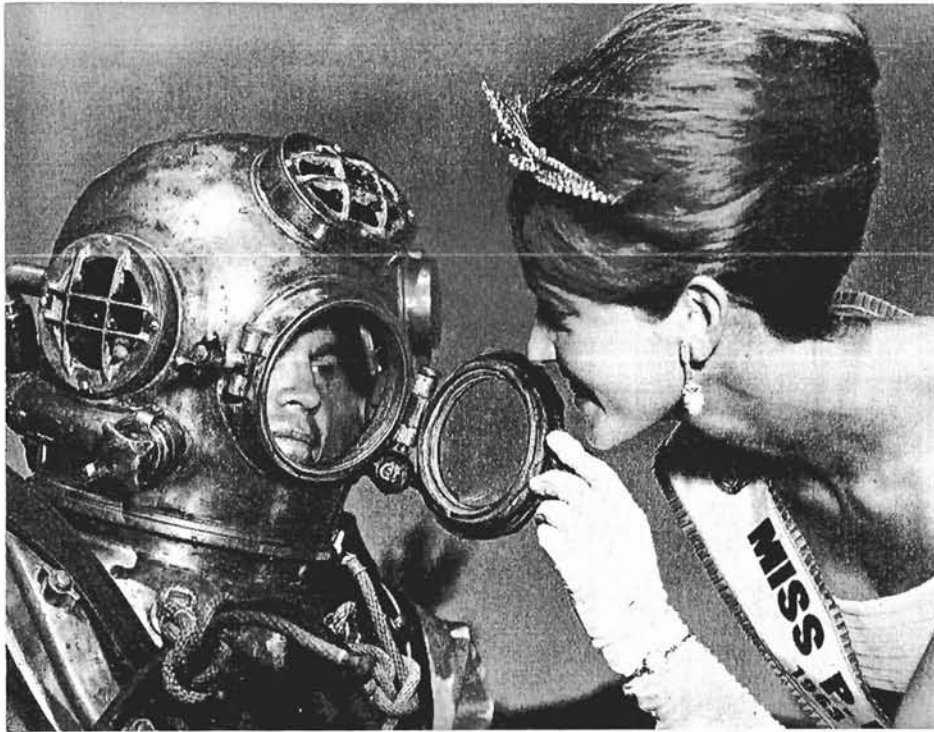

"Well, what do you know? These things have people in them." This or other appropriate remarks may have been made by Miss Pacific National Exhibition, Linda Douma, 20, of Sidney, B.C., when she discovered AB Gordon Benjamin inside the deepsea suit. He was one of a group of naval divers performing daily at the Armed Forces Display at the PNE in Vancouver. (E-77900)



With a view to improving aircraft maintenance through inter-squadron competition, Lt.-Cdr. I. M. Brown, USN, serving in Ottawa on loan to the RCN, has presented an Air Squadron Technical trophy to be competed for annually by air squadron technical departments. He is shown presenting the trophy to Captain John Doherty, Director General Aircraft. (O-15618)



Seventy-three Short Service Officer Plan Naval officer cadets checked in at HMCS Venture on Sept. 3 to begin training leading to commissions in the RCN. Their first day of naval life saw the issue of clothing and textbooks, a prelude to 13 months of professional and academic training ashore and afloat. Bearing up under the initial load are, left to right, B.C. Cadets Michael G. Dalzell, 18, of Victoria; James A. Helps, 20, of Sidney; Thomas G. Watson, 18, of Duncan; and Bernhard Van Ek, 19, of Sooke. (E-78032)



To do honour to the first helicopter landing on HMCS Nipigon's flight deck, a ceremony was held on July 31 in her wardroom. The helicopter, a Sikorsky HO4S from Utility Squadron 21 piloted by Lt. G. A. (Sid) Potter, landed during a compassionate mission. An "ookpik", the Nipigon's mascot, and a lighter were presented to Lt. Potter and a scroll commemorating the occasion to the squadron. Lt.-Cdr. D. A. Muncaster, executive officer of HU-21, accepted the scroll on behalf of the squadron from the captain of the Nipigon, Cdr. D. R. Saxon. (HS-75786)

AFLOAT AND ASHORE

PACIFIC COMMAND

HMCS *Margaree*

Canada was represented at Seattle's annual Seafair in August by the *Margaree*. She found herself in the company of U.S. Ships *Saint Paul*, *Salisbury Sound*, *Somers* and *Hamner* and ships of Minesweeping Division 73.

A royal welcome greeted *Margaree* and her commanding officer, Cdr. J. L. Panabaker. On hand were the acting Canadian consul-general, J. D. Turner, and King Neptune and the Queen of the Seas with their splendidly attired court of local and visiting princesses. The 13th Naval District band and a local orchestra provided atmosphere and many interested spectators greeted the ship and her company.

Numerous social functions were given for both officers and men. HMCS *Discovery* sent a 25-piece band to accompany the 60-man guard landed by *Margaree* for the three-mile-long torchlight parade on Saturday evening.

The hospitality of the Seattle people will long be remembered and the success of their Seafair was obvious. Seattle police estimate that about 260,000 people saw the torchlight parade on Aug. 8.

On return to Esquimalt on Aug. 10, the *Margaree* flew her paying off pennant. She was to go to civilian contractors for conversion.

ATLANTIC COMMAND

HMCS *New Waterford*

Not every ship is given an opportunity to visit and re-acquaint herself with, as it were, her family tree. An exception to the rule this summer, however, was HMCS *New Waterford*, ocean escort of the Seventh Canadian Escort Squadron. In late June, during UNTD Cruise Bravo, she paid a one-day visit to the mining town of New Waterford in Cape Breton from which she derives her name. This has become almost an annual event with the *New Waterford* and is always looked forward to by New Waterfordians from both ship and shore.

However, the name "Waterford" goes deeper than Cape Breton alone. Waterford is an extremely old, very charming

city on the southeast shore of Ireland, boasting a tradition that extends far back to the seafaring Danes of the Ninth Century AD.

As part of UNTD Cruise Charlie, which took the Seventh Escort Squadron to Chatham, England, via the Azores the *New Waterford* and the *Inch Arran* made a four-day operational visit to Cork City during the third week of August. Waterford is only 78 miles from Cork, so it was therefore possible to arrange a meeting of Old and New Waterfordians. The *New Waterford's* executive officer paid an official call on the mayor and civil officials of the city and was received with the best of the traditional Irish "hundred thousand

welcomes". In turn, he presented to them a ship's badge. The mayor expressed his regrets that the ship herself was unable to make the visit.

Both the ship's badge and the city's coat-of-arms have a dolphin in common, a fact which both the Irish and the sailors of the *New Waterford* regard with great interest.

On a subsequent day, a tour of the world-famous Waterford Glass Works was arranged for ship's personnel. The history of Waterford glass is another story but its lead crystal cut-glass decanters, chandeliers, goblets and vases, with their unique designs and superb shapes, can be found in every corner of the globe.

In tribute to the visit of the town's naval namesake, the company presented the ship with a crystal bowl with the ship's badge embossed on its base. It will take its place beside a gift presented to the *New Waterford* in 1961 by the Cape Bretoners.

RCN Divers Help To Pen 'Moby Doll'

"Moby Doll", the captive killer whale, was big news in Vancouver during the past summer and naval divers had something to do with her remaining on the front page.

On July 19 the RCN Diving Establishment, HMC Dockyard, Esquimalt, received a request for help in building a "whale pen" for Moby Doll, then occupying temporary quarters in a floating dock.

The diving team was despatched to Vancouver the following day and set about constructing a pen at Jericho Beach, Vancouver, by tearing out the centre pilings of a little used Department of National Defence jetty. All of the woodwork, piles and debris were removed and the bottom was smoothed by the RCN divers. Two rows of piling were left around the perimeter and between them was erected a 30-foot-high steel wire fence.

The job was unusual, but with good advice from some wire-fence companies and a lot of volunteer help from members of the RCN contingent at the Pacific National Exhibition, the pen was made ready. The job took from Monday to Friday.

The floating dock was positioned at a chute gate and the job of herding a reluctant killer whale into the pen was begun. Says the Diving Establishment's report of proceedings:

"This frustrating, but sometimes thrilling and often amusing, evolution increased the diver's respect for these cunning and intelligent beasts."

It was on into evening before the whale was penned and the gate temporarily secured. The work was completed the following day.

NAVAL DIVISIONS

HMCS *Donnacona*

The role of the RCNR has been defined, in part, as "provision of personnel readily available to activate or augment facilities in support of the RCN."

An opportunity to demonstrate this in a practical manner was presented during the summer to a clearance diving team composed of reservists from HMCS *Donnacona*, Montreal naval division.

A week before the commissioning of HMCS *Nipigon* at Sorel, it was discovered that the ship's EM log was defective and would have to be replaced. An electro-magnetic device for measuring speed, the "log" is attached to the ship's bottom.

Lt. Arthur Morris, the *Nipigon's* engineer officer, cast about for clearance divers and was told of *Donnacona's* reserve team. On learning of the *Nipigon's* predicament, the reservists promptly volunteered to do the job as a training exercise.

Led by "*Donnacona's* diving dentist", Lt. Philip Neroutsos, (*Crowsnest*, October 1961) a team including Lt. C. R. Ward, Lt. Brian Moorehouse, Cadet Michael A. Scott and CPO William Taylor removed and replaced the log in a five-hour operation.

ROYAL MARINES 300 YEARS OLD

A PRIVILEGE granted to the Navy 200 years or more ago—that of drinking the Loyal Toast while seated—has been extended to the Royal Marines by Her Majesty the Queen in recognition of the 300th anniversary of the corps. The Queen's command at the corps tercentary dinner at the Royal Naval College, Greenwich, on July 23, was that the Loyal Toast should be drunk seated in all Royal Marine officer's and NCOs' messes ashore and afloat.

The occasion was one, too, on which the connection of the Royal Marines with Canada and the Royal Canadian Navy was recalled. A message passed to the Commandant-General Royal Marines on July 23 said:

"The Royal Canadian Navy extends warmest greetings to the Royal Marines on the occasion of their 300th anniversary. Royal Marines have been associated with Canada and Canadian forces throughout our history. As early as 1710 they landed at Port Royal, Nova Scotia. They fought with General Wolfe and later served and fought in Ontario. Royal Marines fought alongside Canadians at Dieppe and in other theatres during the Second World War.

"The Royal Canadian Navy is proud of its association with the Royal Marines. It has been a great honour and an inspiration to have a link with a service which has a traditionally high esprit de corps and which excels in all its undertakings."

Oriole Sailors Restore Power

A letter of gratitude has reached the training yacht *Oriole* from the Canadian Fishing Company, Ltd., of Nootka, B.C., on the west coast of Vancouver Island.

During a recent cruise that took the yacht to Nootka, the *Oriole's* sailors learned that the electric light plant of the fishing company had failed. L. H. Ewart, an executive of the company, tells in his letter what happened next:

"The trouble was beyond me, the fish boats were coming in, and it created quite a problem.

"Some of the men of HMCS *Oriole* were at the camp and immediately came over to look into the trouble. It took them very little time and the plant was working like a charm."

In expressing his appreciation, Mr. Ewart concluded: "It is nice to know we have this type of men in our navy. They took it all in their stride as if it were one of those things that is just routine."



UNTD Officer Cadets Michael Campbell and Michael Rayner display a Maritime Museum of B.C. plaque recalling the death by accidental or natural causes of seven Royal Marines and a civilian on San Juan Island when ownership of the island was in dispute a century ago. (E-77648)

The Commandant-General Royal Marines made the following reply:

"I have received your message of greetings on the occasion of our 300th anniversary with the greatest pleasure and gratitude, and I shall ensure that it is brought to the notice of all members of my Corps. We treasure our long associations and operational experiences with the Royal Canadian Navy as much as you are kind enough to say you do with us. I am deeply touched by your thoughtfulness on our tercentenary and the tribute which you have paid us."

An historical connection of the Royal Marines with Canada was recalled during a ceremony on San Juan Island, whose ownership was the subject of a dispute 105 years ago and which is now part of the State of Washington.

On August 9, University Naval Training Division officer cadets from Esquimalt proceeded to the island and erected a plaque commemorating seven members of the Royal Marine Light Infantry and a civilian who died during the boundary dispute. The deaths were from accidental or natural causes during the occupation of part of the island by the Royal Marines. The only shooting casualty was a British pig, whose death from a shot fired by an American settler precipitated the bound-

dary dispute. (A detailed account of the incident appeared in the January 1957 issue of *The Crowsnest*).

The plaque which the UNTDs have placed in the English cemetery on San Juan Island reads:

ENGLISH CEMETERY

In Memory of Seven Members of the Royal Marine Light Infantry and One Civilian Who Died Here during Boundary Negotiations 1860-1872

Erected by the University Naval Training Divisions Royal Canadian Navy for the

Maritime Museum of B.C. August 1964

Thirty UNTD cadets proceeded to the island from Esquimalt in auxiliary training craft for a combination training cruise and presentation ceremony. Accompanying them were Col. J. W. D. Symons, director of the Maritime Museum of British Columbia and Cdr. F. E. Grubb, RCN (Ret), the museums' secretary.

The plaque was received by a representative of Washington State Parks and Recreation Commission.

Dominion Day Rites Praised

High praise was accorded units of the Canadian Armed Forces for their roles in the July 1 ceremonies on Parliament Hill, Ottawa, in a letter addressed to Hon. Paul Hellyer, Minister of National Defence, by Hon. George J. McIlraith, President of the Privy Council.

Mr. McIlraith wrote:

"I was very much impressed by the ceremony yesterday on Parliament Hill given by the Armed forces.

"As you know, I have had more than the usual opportunity of attending Parliament Hill ceremonies over the years. I thought last night's performance by the bands and other units of the Armed Forces were outstanding, perhaps beyond all other occasions with the possible exception of the ceremony on the occasion of the late King's visit."

The RCN's share in the Dominion Day presentation was the Sunset Ceremony by the *Cornwallis* guard and band.

WAR IN THE BALTIC SEA

MY, BUT IT'S GRAND to read how they handled communism before Messrs. McCarthy and Dulles got into the act. Captain Geoffrey M. Bennett, DSC, Ret, FR Hist S, has written the first book-form account of this undeclared war, *Cowan's War, the Story of British Naval Operations in the Baltic, 1918-1920*.

"Cowan" was Admiral Sir Walter Cowan, KCB, DSO and Bar, MVO, First Baronet of the Baltic, a famous little fire-eater. Here is how he described the chaos he had to resolve:

"It seemed to me that there was never such a tangle, and my brain reeled with it. An unbeaten German army, two kinds of belligerent Russians, Letts, Finns, Estonians, Lithuanians; ice, mines—60,000 of them! Russian submarines, German small craft, Russian battleships, cruisers and destroyers, all only waiting for the ice to melt to ravage the Baltic."

Author Bennett writes: "Cowan first went to the Baltic as a junior rear-admiral with a couple of cruisers and half-a-dozen destroyers. Within a year his force comprised every type of war vessel, except for capital ships, and was of a size rarely commanded by an officer of his seniority. His initial purpose was to encourage Estonia and Latvia to resist Bolshevik aggression. It became a campaign against a hostile fleet while helping four separate states to maintain their newly declared independence against virulent Bolshevism, Prussian Imperialism and White Russian ambitions; and he was required to do it with his hands tied by the ambivalent attitude of the Allies towards Intervention and reluctance to force a German withdrawal."

Regarding the German situation, the pithy observation "East Prussia does not realize that Germany has lost the war," by the British representative on Niessel's Commission, is coupled in a footnote to the more realistic view of the Weimar Government: "All the woes that pelted us this autumn would never have occurred if the German Nationalists had not convinced the troops that they were strong enough to hold the Baltic states against a victorious world."

Junior in rank Cowan may have been, but he was the tough nut needed if the independence of these little buffer states was to be assured. In spite of the paucity of direction from Whitehall, Paris and Versailles, he succeeded.

BOOKS for the SAILOR

Freedom for three of the Baltic states was brief—1921-41. The Reds annexed them for military bases.

Captain Bennett does not venture into world strategy and his mention of the 1941 annexation is purposefully brief. He doesn't say whether or not the encouragement of independent states in the Baltic was ultimately a good thing

or a bad thing in the light of later events.

What he has done, and this is valuable enough, is to give us a comprehensive book on the subject. He rather jumps about for the first part of the book and some of this could have been tied down by better organization of the wealth of material he worked with, although much can be forgiven because of the chaos of which he wrote.—H.C.W.

COWAN'S WAR, *The Story of British Naval Operations in the Baltic, 1918-20*, by Geoffrey Bennett; 254 pages, illustrated and appended; published in Canada by Messrs. Collins, 10 Dyas Road, Don Mills, Ont.; \$6.75.

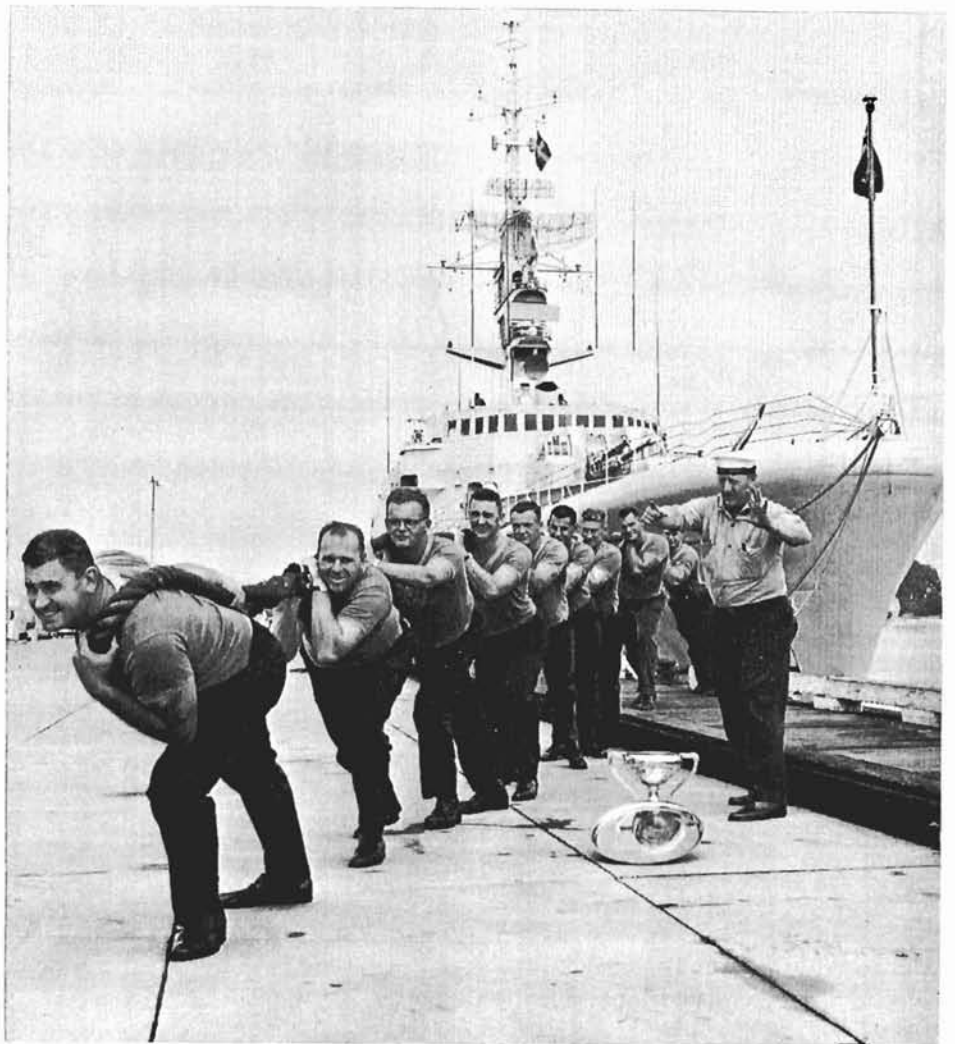

This probably explains why the tug-o'-war team from HMCS Saskatchewan, coached by Ldg. Sea. David Hill, holds the squadron championship, has top place in Pacific Command and recently copped highest honours in a Highland Games tug event held in Victoria. The coach claims six-inch hawser is "ideal for workouts". Heaviest member is 257 pounds; lightest is 195, and the average is 225 pounds. Team members are Lt.-Cdr. Robert Dougan, PO Wilfred Yurgensen, PO Tom Trotter, JO John LaFave, Ldg. Sea. Leonard Wortman, Ldg. Sea. Leonard Mein, AB Richard Roberts, AB Ray Beasley, and Ldg. Sea. GERAL Walker. (E-77694)

SUBMARINE'S LOSS REMAINS MYSTERY

IN HIS *Death of the Thresher*, Norman Polmar brings readers a fine (and inexpensive!) book which encompasses just about all that was made public knowledge on the tragic sinking of this nuclear attack submarine off Boston on April 10, 1963, with 129 souls on board.

Submarine sinkings make the front pages of the worlds' newspapers on the rare occasions they occur in peace time. The *Thresher*, being the first atomic craft to go down, dominated the news for weeks and coverage continued for many months as the investigation of her sinking unfolded. The search ended after five months.

Mr. Polmar is a veteran journalist who helped edit naval-oriented publications before joining the prestigious *U.S. Naval Institute Proceedings* as assistant editor. He traces the history of this lead boat of her class, explores in the fullest possible detail her fatal accident, and then reviews the possibilities that were weighed as to why she sank during a deep-dive test just off the continental shelf east of Boston and south of Nova Scotia.

Certain aspects of the *Thresher* and her destruction remain classified but Polmar wrote skillfully around these empty patches. The illustrations are top line and there are enough of them, even with security measures, to give the best available picture of what might have happened.

Polmar refuses to speculate. He reviews the possibilities that were established by investigation, as a good journalist should. To the public, at least there is no clear-cut reason established for the loss of the *Thresher*. The official Secretary of the Navy statement said, in part:

"A flooding casualty in the engine-room is believed to be the 'most probable' cause of the sinking of the nuclear submarine USS *Thresher* . . ." and Polmar adds:

"Ambiguous and indefinite. *Exactly* (author's italics) what caused the worst submarine disaster in history will probably never be known."

It is perhaps the newspaperman in Mr. Polmar that caused him to find out how the story of the *Thresher's* loss first broke. It broke in Halifax, N.S., as the search for the missing submarine expanded.

Polmar writes, "Far to the north, the Canadian Navy was asked to stand by to assist in whatever operations might be necessary.

"The *Thresher's* last reported position was only about 100 miles off the tip of Nova Scotia. Canadian Naval Headquarters quickly alerted one of the British Navy submarines based there to stand by to get underway. As the submarine's skipper ordered his crew rounded up, a rumour began to spread that a United States submarine was in trouble.

"A newsman at television station CJCH heard the rumour and the station interrupted its program with the bulletin: 'U.S. submarine reported in danger of sinking or in trouble on the high seas.'

"The secret was out . . ."

The actual rumour began with a recalled submariner telling his taxi driver

on the way to the dockyard that a submarine was in trouble and his boat was being readied. The taxi driver tipped off radio station CHNS. The station ascertained that no submarine under RCN control was in trouble and let it go at that, refraining from leaping to the conclusion of the TV station when it finally picked up the rumour.

Death of the Thresher reads well indeed. It covers a great deal in only 150 pages, and the account of the search for the wreckage a mile and a half under water is of high interest, particularly where it deals with the efforts of the bathyscaph *Trieste*.

For some reason or other, Author Polmar makes no mention at all of British peace-time disasters, not even that milestone attempt to save HMS *Affray* in 1950 when underwater television was used for the first time.—H.C.W.

DEATH OF THE THRESHER, by Norman Polmar; published in Philadelphia by Chilton Company and simultaneously in Toronto, Canada, by Ambassador Books, Ltd.; illustrated, 150 pages; \$3.95.

ORIGIN OF NAUTICAL WORDS DISPUTED

TWO NAUTICAL WORDS, canoe and hammock, are almost invariably stated by standard dictionaries to be of West Indies origin, via Spanish.

Not so, says an English professor, Charles F. Fromme, Jr., of Battersea College, London, in a letter appearing in the Aug. 21, 1964, issue of *Science*, official publication of the American Association for the Advancement of Science.

The writer draws attention to a statement in an article on "Prehistory of the West Indies" which said both words came from the language of the West Indian aboriginals.

"This statement, I fear is premature," says Mr. Fromme; "the origins of both words are open to further consideration and research.

"The word *canoe* has a long etymological history on the centum side (roughly, the European group) of the Indo-European language family, and its roots can be seen in both the Germanic and Latin (Italic) branches. The root *can* or *kan* ('boat') existed in all the languages with which English has had contact; the root *can* was in the Spanish language of the pre-Columbian period.

"The etymology of *hammock* must be considered in two parts—the origin of the orthography, and the origin of the basic meaning. The spelling is from the nautical term *hammock* (or *hummock*, knoll used as a navigational landmark). The origin of the meaning is basically Germanic, from the old High German *himil* or the Dutch *hemel* (meaning heaven, canopy), through the 14th century English *hammercloth*, canopy), to the 16th century English *hammercl'* or *hammock*. Both *hammock* and *hammercloth* have the meaning of a cloth or fibre mat stretched between two supports."

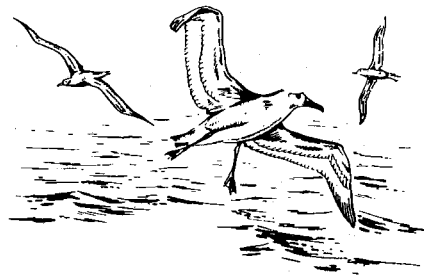

THE NAVY PLAYS

Shore Types Lead In Sailing Races

Atlantic Command shore establishments took the spotlight recently as whaler and "420" teams raced off for the Establishment trophy at the Army-Navy Sailing Club.

Gusting winds took their toll as 420s and whalers were swamped or capsized. Of those who remained afloat, the crews from HMCS *Cornwallis* emerged as the 1964 winners of the trophy, placing first in the 420s and fifth in the whalers.

Cornwallis beat out teams from the Naval Research Establishment, Dartmouth, who placed second, HMCS *Shearwater*, third, the 6th Submarine Squadron and HMCS *Scotian* tied for fourth, and HMCS *Stadacona*, fifth.

Cadets Excel at Highland Games

A team of UNTD athletes from HMCS *Cornwallis* took top honours in the open men's track and field events on the last day of the 101st Antigonish Highland Games at Columbus Field, Antigonish, N.S., on July 18.



The Bluefin Swimming Team of Naval dependents sponsored by *Shearwater* almost swept the board when it won places on the Nova Scotia team entering the Canadian Olympic trials. The club is part of the Children's recreation program at *Shearwater*. The Bluefins, 40 strong, hold seven Canadian records and about 100 others. Six of their swimmers were chosen in open competition to help represent Nova Scotia at the Vancouver Olympic Trials in August. The group made its debut in national competition at Montreal last year at the Canadian championships. Pictured are, top row, Arlene Henderson, Randy Near and Anne-Marie McCarthy; standing, PO Peter Britton (coach) and Lt.-Cdr. John Kennedy, *Shearwater* sponsor, and front, Beverly Britton, Janet Bruce and Lynn Palmer. (DNS-33780)



"Love that little golf ball." Rear-Admiral W. M. Landymore, Flag Officer Pacific Coast, looks with admiration and affection on the ball that obediently took flight and came to rest just where he hoped, but never thought, it would. The hole-in-one was shot on the 146-yard second hole at the Victoria Golf Course in June. (E-76793)

The UNTDs, whose relay team set a record, accumulated 58 points during the day's events to edge out the Antigonish Highland Society by one point.

The *Cornwallis* team's record was in the 440-yard relay, which was run off by Officer Cadets Jim McRae, Bill Shambrook, John Warrington and Keith Mills in 44.9 seconds.

Cornwallis entered two teams in the

one-mile relay, finishing first and third and thereby gathering in 14 points.

Two individual *Cornwallis* winners were Cadets G. J. Marois, first in the 440-yard dash, and Keith Mills, who won the hop, step and jump.

The *Cornwallis* contingent of 25 cadets and four officers led the Highland Games parade through the streets of Antigonish.

Biathlon Ski Team Planned

The Canadian Armed Forces have been authorized to form and train a national biathlon ski team to represent Canada in the 1968 Winter Olympics.

The biathlon competition is between teams, each composed of six men and a spare, in cross-country skiing and rifle shooting over a course of approximately 20 kilometres (about 12 miles).

An applicant for preliminary selection must be between 18 and 25 years of age, below the rank of lieutenant-commander, an expert shot, physically fit and capable of undertaking intense endurance training, a proficient skier, with experience in service or civilian competition, and must be prepared to serve until after the 1968 winter Olympics.

A team manager, rifle coach and ski coach will also be required.

New Entry Sets Record in 880

Ord. Sea. G. U. Wunderlich, of *Margaree* division, was presented with the team trophy for recent new entry track and field championships at HMCS *Cornwallis* by Rear-Admiral J. V. Brock, Flag Officer Atlantic Coast.

Wunderlich, who won the high jump, also set a new record for the 880-yard run, completing the distance in 2:21:0. He was also on the half-mile and one-

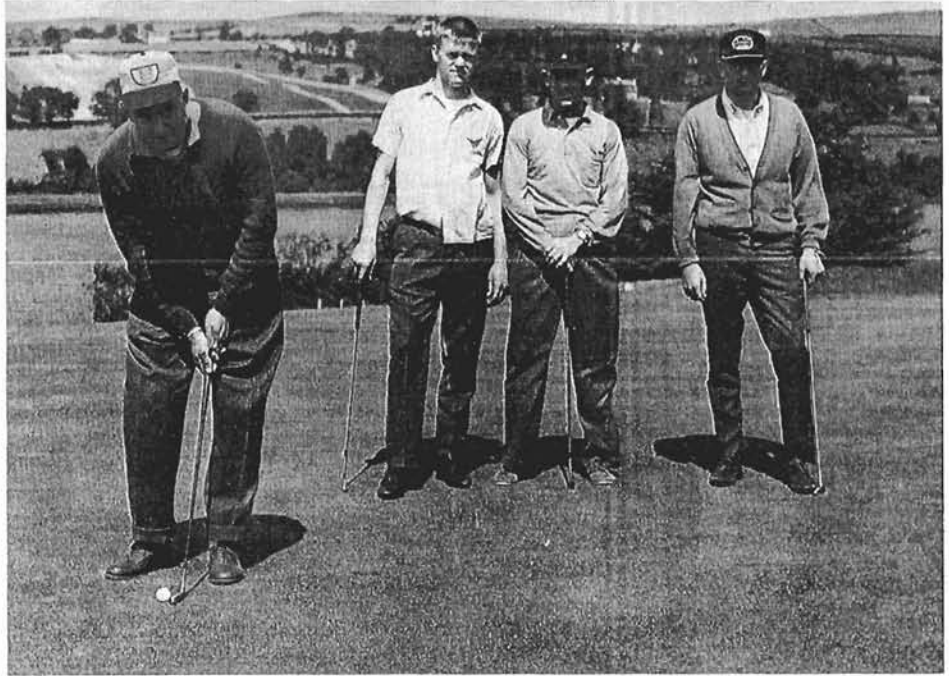

CPO Trevor Davies, left, of the Yukon, who won the First Canadian Escort golf tournament during a visit to Londonderry, Northern Ireland, this summer, prepares to putt on the 18th hole of the Derry Golf Club. He shot an 84. Others in the foursome, left to right: AB B. J. Bryan, of the Algonquin, who took second place with an 88; Lt. J. U. Graham, of the St. Laurent, and PO R. J. Gillespie, of the Crescent. (CCC1-374)

mile relay teams. He lists basketball, soccer and volleyball as his favourite sports.

Ord. Sea. Wunderlich, who is 19, came to Canada nine years ago after fleeing from East Germany with his mother, father and brother. After spending a

year in West Germany, the family moved to Canada, taking up residence in Montreal.

Although satisfied with his present become a physical and recreational trade of steward, he hopes eventually to training instructor.

CRUISE CERTIFICATES AVAILABLE

A SMALL NUMBER of cruise certificates, going back more than a quarter of a century, are still available for those who have mislaid their mementoes of past voyages or who did not receive one at the time.

Cdr. H. W. S. Soulsby, RCN (Ret), of 2150 Granite Street, Victoria, has written to say that he has a limited number of copies of certificates for RCN cruises between 1938 and 1964. These are available for \$1 each, including the lettering of name and rank of those who provide some verification of having gone on the cruise or cruises.

The 1938 certificate, of which two copies are available, commemorates the cruise of the *Skeena*, *Saguenay*, *Fraser*, and *St. Laurent* to South America.

"I drew it while serving in the *Armentieres* when we were at Bamfield, acting like a lifeboat," Cdr. Soulsby recalls.

"Each year, between the two World Wars, the *Armentieres* and the Fisheries Protection Ship *Givenchy* shared the 'Bamfield Patrol', which meant spending seven weeks between November 25 and the end of February at Bamfield, 100 miles west of Victoria, at short notice, ready to go to the assistance of any ship in distress on that portion of the west coast of Vancouver Island.

"Our aid was not often required, which was a good thing, because these little ships were really only capable of looking after themselves in any kind of bad weather."

In addition to the certificate commemorating the South American cruise of 1938, the following are available, with the number of each shown in parentheses:

1950, *Magnificent*, *Micmac* and *Huron*, Canadian Special Service Squadron to Europe (1 only); 1952, *Ontario*, South America (2); 1954, *Ontario*, Australia (6); 1953-54, *Haida*, Korea and round the world (1 only); 1954, *Quebec*, South America (in French, 2, in English, 1); 1955, *Ontario*, Australia (1 only); 1955, *Ontario*, Europe, (2); 1955, *Quebec*, Africa (3);

1956, *Ontario*, three cruises; Japan, Ecuador and West Indies (3); 1957, *Ontario*, *Stettler*, *Jonquiere*, to Hong Kong, Singapore, etc. (2); 1958, *Ontario*, Australia, New Zealand, etc. (2); 1959, *Sussexvale*, *Beacon Hill*, *Antigonish* and *St. Therese*, Fiji, Samoa, etc. (2); 1960, *Sussexvale*, *Stettler*, *St. Therese* and *Antigonish*, San Francisco and Valparaiso (3); 1962, *Assiniboine*, *Margaree* and *Ottawa*, Far East, Japan, etc. (3); 1963, *Saskatchewan*, Halifax, England, San Juan, etc. (1); 1964, *Fraser*, Far East, etc. (2).

RETIREMENTS

CPO GEORGE GORDON BORGAL, CD; C2BN4; joined RCNVR May 12, 1938; transferred to RCN May 6, 1940; served in Halifax naval division, *Stadacona*, *Bras d'Or*, C2BN4; joined RCNVR May 12, 1938; transferred to RCN May 6, 1940; served in Halifax naval division, *Stadacona*, *Bras d'Or*, *Saguenay*, *Cornwallis*, *Niobe*, *Kootenay*, *Hochelaga*, *Cape Breton*, *Lauzon*, *Peregrine*, *Naden*, *Mimac*, *HMS Excellent*, *Haida*, *Wallaceburg*, *Huron*, *Algonquin*, *Swansea*, *Sioux*; retired August 6, 1964.

CPO QUENTIN HAROLD DIBNAH, CD and 1st Clasp; C1WR4; joined RCNVR Nov. 27, 1940; transferred to RCN July 17, 1941; served in Winnipeg naval division, *Stadacona*, *Venture*, *Cornwallis*, *St. Laurent*, *Givenchy*, *Naden*, *Uganda*, *Ontario*, *Chippawa*, *Donnacona*, *Athabaskan*, *Niobe*, *HMS Victory*, *Hochelaga*; retired August 2, 1964.

PO GEORGE WILLIAM DUNKERLEY, CD; P2CK2; served in RCNVR March 26, 1940-Sept. 5, 1945; joined RCN May 7, 1951; served in *Stadacona*, *Comox*, *Husky*, *Chaleur II*, *Nabob*, *Niobe*, *Humberstone*, *Swansea*, *Peregrine*, *Captor II*, *Scotian*, *Naden*, *Quebec*, *Bonaventure*, *Shearwater* (VF 870), *Cape Scott*; retired August 16, 1964.

CPO RICHARD MELVIN DUPCHAK, CD; C1RA4; joined Oct. 19, 1945; served in *Chippawa*, *Cornwallis*, *Niobe*, *HMS Duke*, *HMS Ariel*, *Stadacona*, *Warrior* (825 Squadron), *Niobe*, *RNAS Eglinton* (19CAG), *Magnificent*, *Bytown*, *Shearwater*, *Shearwater* (30CAG), *Magnificent* (VS 871), *Shearwater* (VF 870); retired August 12, 1964.

CPO ORVILLE BRUCE GRAVES, CD; C2BN4; served in RCNR Sept. 22, 1939-Nov. 15, 1945 and March 8, 1951-March 2, 1952; joined RCN March 3, 1952; served in *Stadacona*, *French*, *Protector*, *Q054*, *Somers Isles*, *Peregrine*, *Scotian*, *Cornwallis*, *Shearwater*, *Quebec*, *Albro Lake Naval Radio Station*, *Bonaventure*; retired August 16, 1964.

CPO WILLIAM ALEXANDER LORNE HUGHES, CD; C1SG4; served in RCNVR May 30, 1939-Sept. 9, 1944; joined RCN Sept. 10, 1944; served in Ottawa naval division, *Stadacona*, *Fundy*, *Fleur de Lis*, *Caribou*, *Venture*, *Saskatoon*, *Georgian*, *Avalon*, *St. Hyacinthe*, *Hepatica*, *Hochelaga II*, *Portage*, *Peregrine*, *Chaleur*, *Carlplace*, *Niobe*, *York*, *Albro Lake Radio Station*, *Magnificent*, *Cornwallis*, *Quebec*, *Fort Erie*, *Bonaventure*, *Buckingham*, *Cape Scott*; retired August 10, 1964.

CPO WILLIAM GEORGE JOHNSTONE, CD; C2CM4; served in RCNVR April 28, 1941-Nov. 13, 1945; joined RCN April 2, 1946; served in Hamilton naval division, *Naden*, *Royal Roads*, *Sans Peur*, *Stadacona*, *Sorel*, *RNAS Dartmouth*, *Peregrine*, *Cornwallis*, *Sioux*, *York*, *Scotian*, *Haida*, *Shearwater*, *Magnificent*, *Mimac*, *Nootka*, *Hochelaga*; retired August 22, 1964.

PO GRAHAM ALEXANDER McKAY, CD and 1st Clasp; joined RCNVR April 18, 1939; transferred to RCN May 6, 1940; served in Calgary naval division, *Naden*, *Nootka*, *Stadacona*, *Niobe*, *Mayflower*, *St. Francis*, *St. Hyacinthe*, *Venture*, *Canso*, *Chatham*, *Givenchy*, *HMS Belfast*, *Huntsville*, *Le Pas*, *Peregrine*, *Cornwallis*, *Ottawa II*, *Grandmere*, *Scotian*, *Coverdale*, *Ontario*, *Aldergrove*, *Antigonish*, *Cayuga*, *HMS Dolphin*, *HMS/M Adamant*, *Ste. Therese*, *Tecumseh*; retired August 30, 1964.

CPO REGINALD BALDWIN RIMMER; C1LT4; joined July 31, 1939; served in *Naden*, *HMS Malaya*, *Stadacona*, *Restigouche*, *Q052*, *Cornwallis*, *Givenchy*, *Oakville*, *Peregrine*, *Niobe*, *Haida*, *Sioux*, *Rockcliffe*, *Cayuga*, *Sioux*, *Churchill*, *Ontario*, *Antigonish*, *Niobe II*, *Bonaventure*, *Hochelaga* (PNO), *Chaudiere*, *Montcalm*, *Hochelaga*; retired August 2, 1964.

CPO JAMES RODGERS; C1CM4; joined August 6, 1939; served in *Naden*, *Armentieres*, *Sans Peur*, *Stadacona*, *Restigouche*, *Avalon*, *Assiniboine*, *Niobe*, *Cornwallis*, *Iroquois*, *Montcalm*, *Uganda*, *Cayuga*, *Antigonish*, *Athabaskan*, *Royal Roads*, *Ottawa*; retired August 5, 1964.

OFFICERS RETIRE

LT.-CDR. EMILIAN ADAMIC, CD; commenced service in the RCNVR August 22, 1941 as a probationary writer; promoted to probationary paymaster sub-lieutenant on August 30, 1944; served in *Naden*, *Givenchy*, *Cornwallis*, *Avalon*, *Stadacona*, *Stettler*, *St. Hyacinthe*, *Donnacona*; transferred to RCN as lieutenant (S) May 30, 1941; served in *Donnacona*, *Stadacona*, *Naden*, *Rockcliffe*, *Sioux*, *Discovery*, *Iroquois*, *Athabaskan*, *Huron*, *Cornwallis*, *Restigouche*, *Resolute*, *Hochelaga*; last appointment, HMCS *Hochelaga* on staff of Naval Officer-in-Charge Montreal as Administrative Officer and on staff of Senior Naval Officer River St. Lawrence Area as Command Security Officer; commenced leave August 6, 1964; retires on Feb. 22, 1965.

LT. (N/S) BEATRICE VERA BURTON, CD; commenced service on Jan. 19, 1942, as a nursing sister; served in *Stadacona*, *Avalon*, *Protector*, *Hochelaga*, *York*, *Cornwallis*; last appointment, HMCS *Stadacona* for Canadian Forces Hospital, Halifax; commenced leave Aug. 28, 1964; retires on March 6, 1965.

LT.-CDR. CHARLES PRESTON CLARK; served during Second World War in Canadian Army, later transferred to RCAF; joined RCN(R) on June 13, 1949, as lieutenant (SB); transferred to RCN as lieutenant (SB), June 20, 1950; served in *Bytown*, *Swansea*, *Hochelaga*; last appointment Naval Headquarters on staff of Naval Secretary as officer-in-charge Naval Art Section; commenced leave Aug. 16, 1964; retires on Nov. 13, 1964.

LT.-CDR. PHILIP CHESHIRE HAMEL COOKE, CD; joined RCNVR September 5, 1940, as acting sub-lieutenant; served in *Stadacona*, *Venture*, *Hochelaga II*, *Ottawa*, *Cornwallis*, *Naden*, *Niobe*, *HMS Osprey*, *HMS Hart*, *HMS Glenarm*, *HMS Strule*, *York*; de-

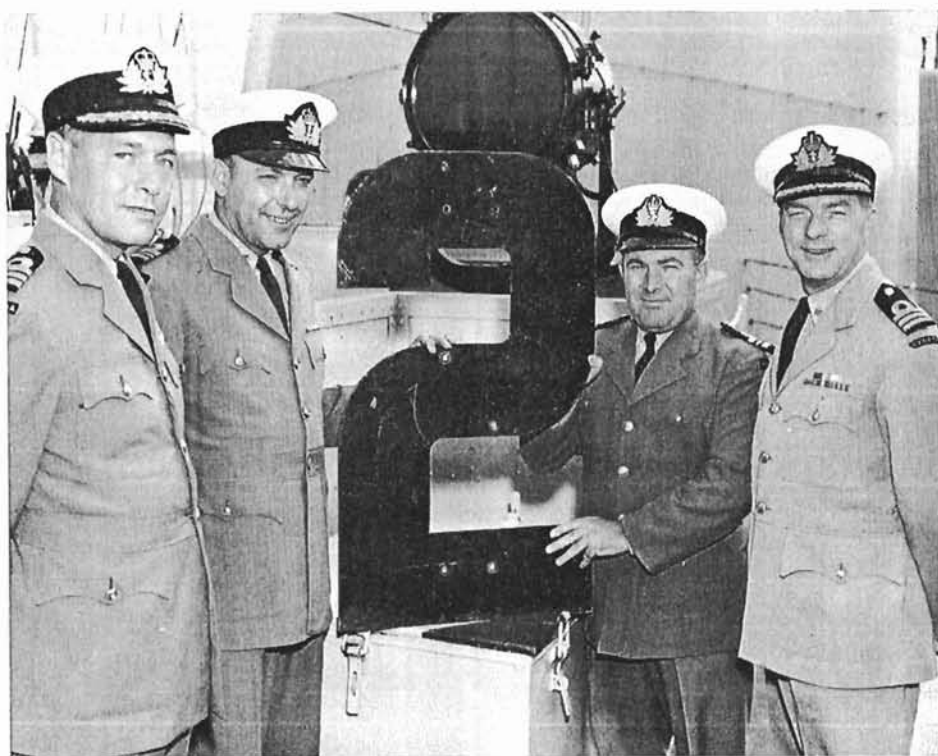

The commanding officers and executive officers of HMCS *St. Laurent* and HMCS *St. Croix* complete the exchange of ships' companies at Halifax, with the presentation of *St. Laurent's* funnel marking to *St. Croix*. Left to right: Cdr. J. S. Hertzberg, Lt.-Cdr. G. D. Pearce, Lt.-Cdr. S. G. Machan and Cdr. D. D. Lee. (HS-75771)

mobilized Nov. 6, 1945; joined RCN(R) Jan. 27, 1948, as lieutenant (A/S); transferred to RCN as lieutenant (TAS) (D) Sept. 28, 1948; served in *Chippawa, Bytown, Stadacona, Magnificent, Beacon Hill, New Glasgow, Niagara, York, Inch Arran, Royal Roads*, as executive officer; commenced leave August 30, 1964; retires on Feb. 2, 1965.

LT.-CDR. SIDNEY CHARLES CROUCHER; commenced service in the RCN(R) Oct. 3, 1951, as lieutenant; transferred to RCN as lieutenant-commander June 10, 1952; served in *York, Bytown, Cayuga, Naden, Royal Roads*; last appointment Naval Headquarters on staff of Director of Naval Organization and Management as Staff Officer Ships and Mobilization; commenced leave Aug. 26, 1964; retires Dec. 14, 1964.

CDR. DENZIL THOMAS RALPH DAWSON, served in the RCNVR from Aug. 21, 1940 to Nov. 26, 1945; entered as acting paymaster sub-lieutenant; served in *Stadacona, Venture, Fort Ramsay, Niobe, York*; entered RCN(R) Dec. 26, 1945 as commander (S); transferred to RCN as acting lieutenant-commander (S) on Jan. 17, 1946; served in *Bytown, Niobe, Magnificent, Shearwater, Naden, Patriot, Stadacona*; last appointment HMCS *Stadacona* on secondment to National Productivity Council for National Nova Scotia Work Study School; commenced leave Sept. 1, 1964; retires on Feb. 28, 1965.

LT.-CDR. DONALD FULTON, CD; commenced service in the RCNVR Feb. 8, 1943 as probationary paymaster sub-lieutenant; served in *Cataraqui, Cornwallis, Burrard*; transferred to RCN March 7, 1946 as lieutenant (S); served in *Outremont, Bytown, Naden, Ontario, Niobe, Donnacona, Hochelaga, Crescent*; last appointment Naval Headquarters on staff of Director General Naval Supply as Assistant Director General Naval Supply Administration; commenced leave Sept. 1, 1964; retires on March 6, 1965.

LT.-CDR. ROBERT MANSFIELD GREENE, CD; commenced service in the RCNVR July

15, 1940, as ordinary seaman; promoted to probationary sub-lieutenant on May 24, 1943; served in *Stadacona, Acadia, Cornwallis, Charny, Avalon, Kings, Venture, Uganda*; transferred to RCN as lieutenant, Nov. 14, 1945; served in *Stadacona, Scotian, Niobe, Warrior, Magnificent, Shearwater, Haida, Micmac, Bytown, Sault Ste. Marie, La Hullose, Nonsuch, Donnacona, Hochelaga, Acadia*; last appointment HMCS *Donnacona* as Area Officer Sea Cadets; commenced leave Aug. 19, 1964; retires on March 14, 1965.

CDR. WILLIAM HASTINGS HOWE, CD; commenced service in the RCN on Aug. 14, 1940 as a cadet; served in *Stadacona, HMS Britannia, HMS Durban, HMS Dorsetshire, HMS King George V, HMS Excellent, Sackville, Niobe, Huron, Ontario, Naden, Bytown, Quebec, Niagara, Cornwallis, Huron*; last appointment Naval Headquarters as Director of Naval Communications; retired on Aug. 3, 1964.

CAPTAIN PHILIP REDMOND HURCOMB, CD; commenced service in the RCNVR Feb. 20, 1942, as a sub-lieutenant (SB); served in *Carleton, Stadacona, Bytown*; transferred to RCN Jan. 17, 1946, as commander (SB); served in *Bytown, Ontario*; last appointment Naval Headquarters on Staff of Chief Naval Staff as Judge Advocate of the Fleet and on staff of Chief Naval Personnel as Assistant CNP. (Administration); commenced leave Aug. 4, 1964; retires on February 13, 1965.

LT.-CDR. Henry Philip LEIDL; transferred from Royal Naval Volunteer Reserve Sept. 30, 1945 as a lieutenant (P); transferred to RCN Jan. 14, 1947 as lieutenant (P); served in *HMS Condor, HMS Pintail, Warrior, Stadacona, Givenchy, Crescent, Bytown, Niobe, Discovery, Antigonish, Cayuga, Naden*; last appointment, *Stadacona* on staff of Assistant Commodore Personnel Atlantic Coast (Manning) as Staff Officer Statistics; commenced leave July 22, 1964; retires on Jan. 1, 1965.

CHAPLAIN (P) HARRY PLOUGHMAN, CD; commenced service in the RCN on Nov. 3, 1941, as a chaplain (P); demobilized Sept. 27, 1945; served in *Venture, Stadacona, Avalon, Niobe, Kamsack, Cornwallis*; re-entered RCN as chaplain (P) Dec. 30, 1948; served in *Bytown, Cornwallis, Stadacona, Portage, Naden, Haida, Huron, Gatineau*; last appointment Naval Headquarters on staff of Chaplain General (P) as Deputy Chaplain General (P) Royal Canadian Navy, and as Chaplain of the Fleet (P); commenced leave Aug. 19, 1964; retires on 16 Dec. 1964.

COMMODORE HOWARD LEE QUINN, DSC, CD; commenced service April 3, 1925 in the RCNVR as Ord. Seaman; discharged March 10, 1927; re-entered RCNVR Sept. 6, 1940 as lieutenant; served in *Stadacona, Collingwood, Kings, Cornwallis, Avalon, Eyebright, Givenchy, Strathadam, Beacon Hill*; transferred to RCN March 23, 1946 as lieutenant-commander; served in *Grou, Givenchy, Uganda, Rockcliffe, Naden, Bytown, Magnificent, Niagara, St. Laurent, Stadacona, Niobe, Gatineau, Hochelaga, Cataraqui, Bytown*; last appointment HMCS *Cataraqui* on attachment to National Defence College as Naval Member of Directing Staff; commenced leave Aug. 17, 1964; retires on March 12, 1965.

LT.-CDR. WILLIAM HENRY WATERS, CD; commenced service in the RCN on May 5, 1930, as a boy seaman; promoted to Acting Signal Boatswain on Aug. 15, 1941; served in *Naden, Victory, HMS Hood, Stadacona, Saguenay, Champlain, Fraser, HMS Drake, St. Laurent, Restigouche, Ottawa, HMS Victory, Royal Roads, HMC Signal School, St. Hyacinthe, Avalon, Skeena, St. Croix, Acadia, Cornwallis, Givenchy, La Hullose, Haida, Bytown*; last appointment Naval Headquarters on staff of Director Naval Intelligence; commenced leave Aug. 12, 1964; retires May 8, 1965.



Back from a training cruise to sunny Mexico, four destroyer escorts of the Pacific Command steam into Esquimalt on a grey August day. The ship at the right is HMCS Qu'Appelle. With her on the cruise were the Margaree, Fraser and Mackenzie. (E-77717)

Naval Lore Corner

Number 130
BONUS for the BATTLEFLEET

AT THE START OF WORLD WAR I THERE WERE SEVERAL WARSHIPS BUILDING IN BRITISH YARDS FOR FOREIGN GOVERNMENTS, INCLUDING THREE BATTLESHIPS... ALL OF WHICH WERE TAKEN OVER BY THE ADMIRALTY AT THE COMMENCEMENT OF HOSTILITIES. THESE VESSELS, BUILT TO FOREIGN SPECIFICATIONS, FORMED AN ODD BUT VALUABLE ADDITION TO THE GRAND FLEET. ALL FOUGHT AT JUTLAND, AND ONLY ONE EVENTUALLY SERVED ITS ORIGINAL OWNERS...

H.M.S. AGINCOURT (27,500 TONS) WAS BUILT BY ELSWICK ORIGINALLY FOR BRAZIL AS THE "RIO DE JANEIRO" (IN A BID FOR LATIN NAVAL SUPREMACY), BUT WAS PURCHASED BY TURKEY BEFORE COMPLETION AND RENAMED "SULTAN OSMAN I". SHE WAS SEIZED IN 1914 BY THE ADMIRALTY. SHE HAD THE LARGEST NUMBER OF BIG GUNS AFLOAT (FOURTEEN 12-INCH), AND THE HEAVIEST SECONDARY BATTERY (TWENTY 6-INCH). HER SEVEN TURRETS WERE NAMED FOR THE DAYS OF THE WEEK. (SCRAPPED 1922)...

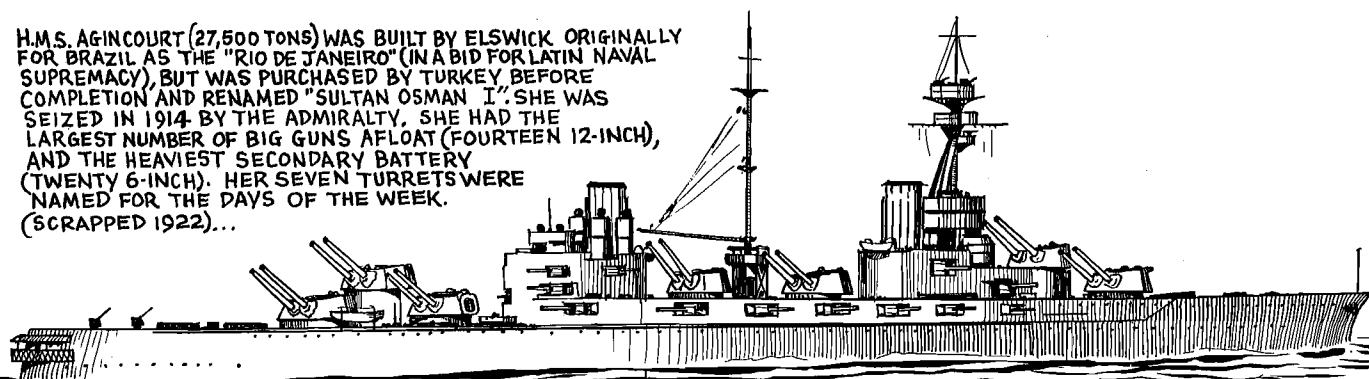

H.M.S. ERIN (23,000 TONS) (BELOW) WAS LAID DOWN AS THE TURKISH BATTLESHIP "RESHADIEH" AT VICKERS IN 1911, AND WAS ACQUIRED BY THE ADMIRALTY IN 1914. HER ARMAMENT WAS TEN 13.5-INCH GUNS AND SIXTEEN 6-INCH GUNS. AS TURKEY BECAME AN ENEMY BELLIGERENT, HER ACQUISITION WAS VERY FORTUNATE. (SCRAPPED IN 1921)

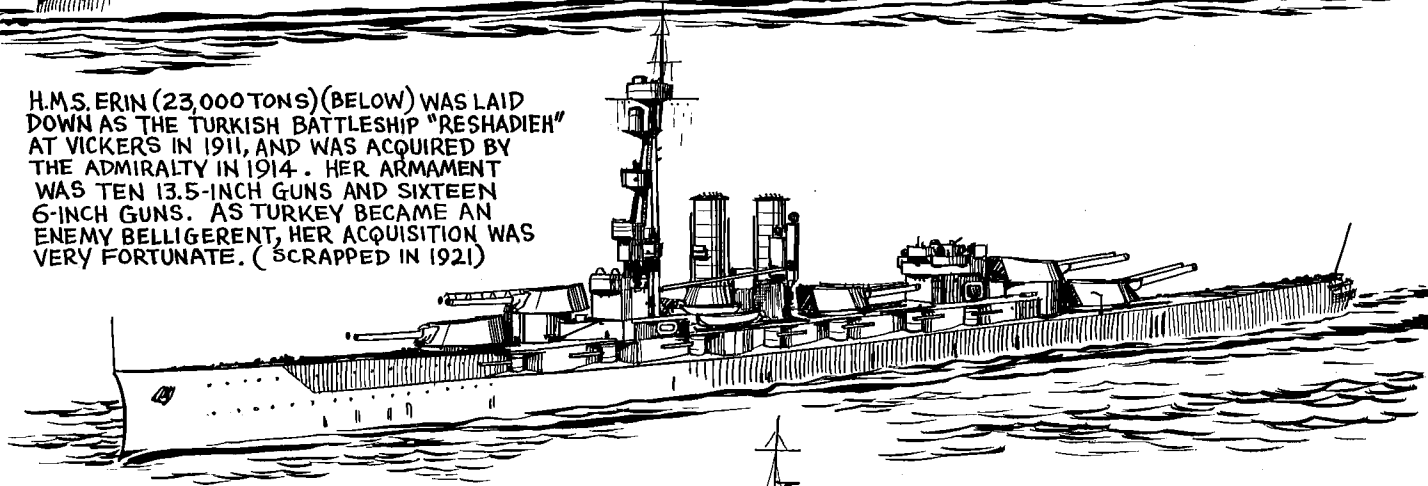

H.M.S. CANADA (28,000 TONS), BUILT AT ELSWICK FOR CHILE AS THE "ALMIRANTE LATORRE" AND PURCHASED BY GREAT BRITAIN IN 1914, SERVED IN THE GRAND FLEET AND WAS RETURNED TO CHILE IN 1920. SHE WAS THE MOST POWERFUL OF THE SOUTH AMERICAN BATTLESHIPS (TEN 14-INCH GUNS) AND WAS SCRAPPED IN 1958. A SISTER-SHIP (EX "ALMIRANTE COCHRANE") WAS EVENTUALLY COMPLETED IN 1924 AS THE BRITISH AIRCRAFT CARRIER "EAGLE"...

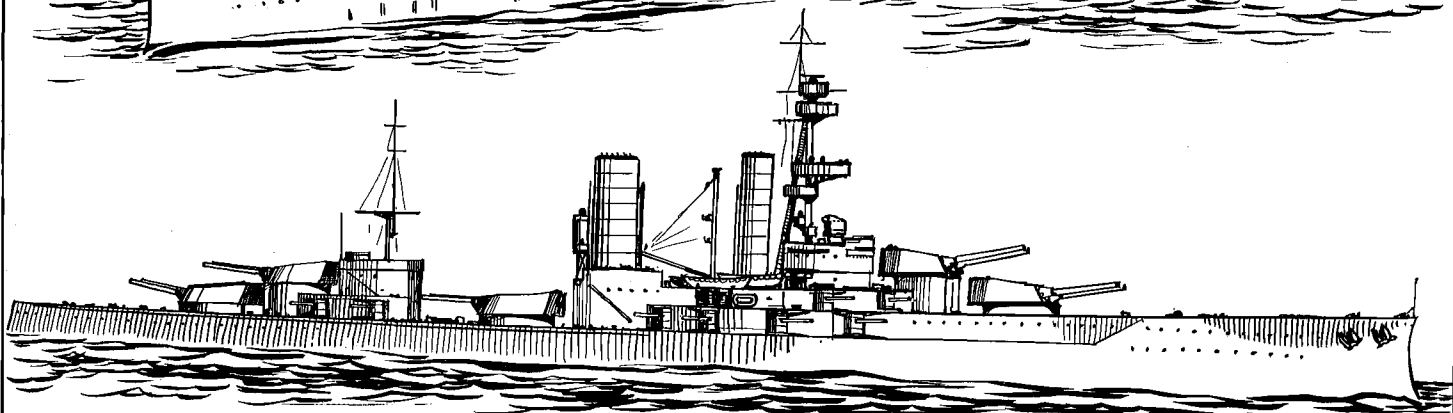

CANADA
POSTAGE PAID
PORT PAYÉ

*If undelivered,
return COVER WITH CONTENTS to:*

The Queen's Printer, Ottawa, Canada

*En cas de non-livraison,
retourner cette PUBLICATION INTACTE à:*

L'Imprimeur de la Reine, Ottawa, Canada



The CROWSNEST



Vol. 16, No. 10

October, 1964

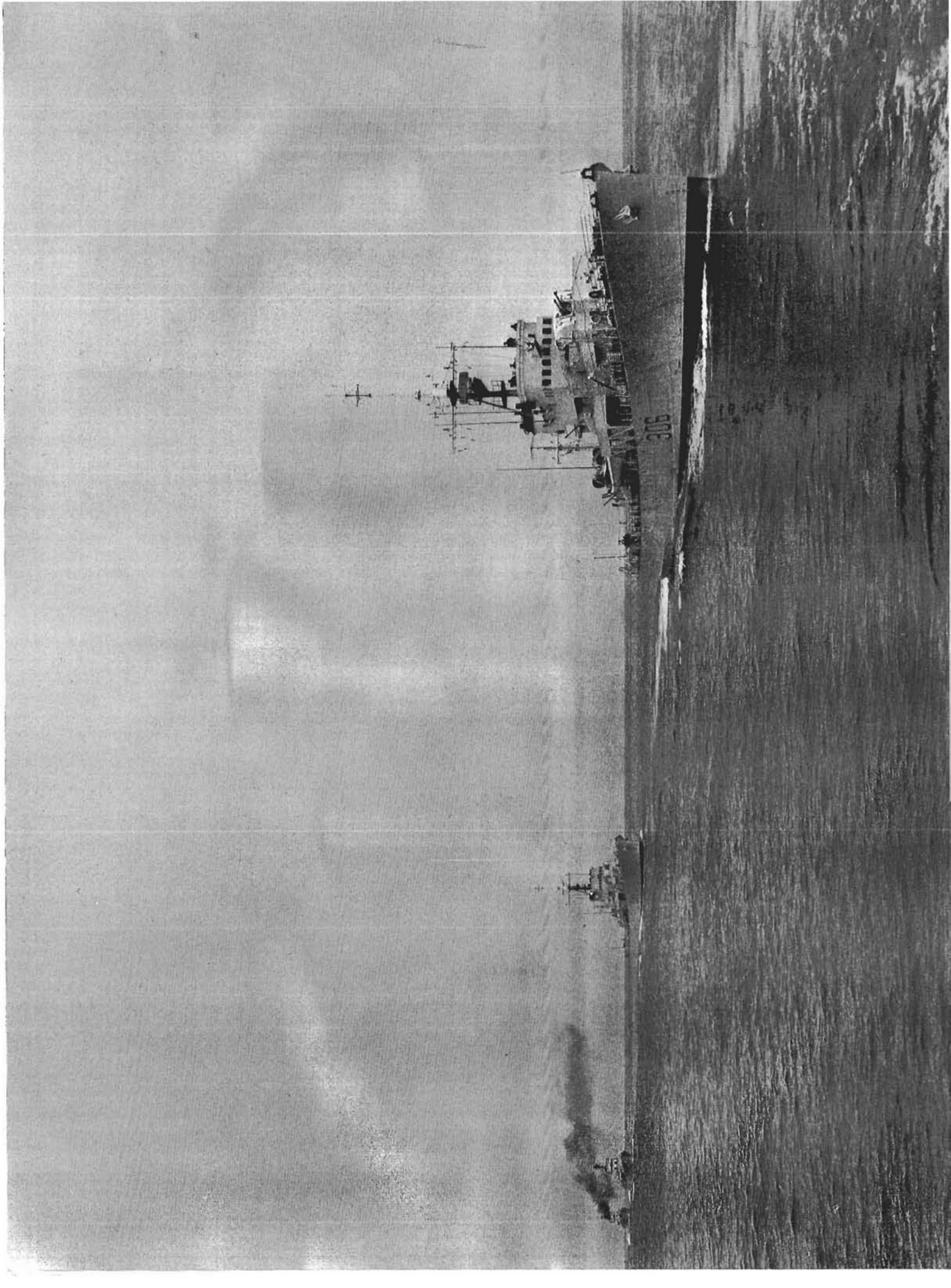

The CROWSNEST

Vol. 16 No. 10

THE ROYAL CANADIAN NAVY'S MAGAZINE

OCTOBER 1964

CONTENTS

	Page
<i>RCN News Review</i>	2
<i>Haida Goes Home</i>	5
<i>Officers and Men</i>	9
<i>The Bilko Image</i>	12
<i>A Letter from the Queen</i>	14
<i>Afloat and Ashore</i>	17
<i>Home from the Sea</i>	19
<i>Books for the Sailor</i>	20
<i>Science and the Navy</i>	23
<i>The Navy Plays</i>	25
<i>Here and There in the RCN</i>	26
<i>Retirements</i>	27
<i>Naval Lore Corner No. 131</i>	<i>Inside Back Cover</i>

LADIES OF THE MONTH

They call them "ocean escorts" now, a somewhat logical, if less romantic, designation than "frigate". The name "frigate" was brought out of retirement during the Second World War by the Royal Canadian Navy to apply to its new twin-screw corvettes and this use spread quickly from navy to navy.

Since the war, "frigate" has been used for many classes of ships, including the former corvettes and minesweepers. More suitably, it has been applied to guided-missile ships of cruiser size.

Thus, it comes about, the picture on the opposite page showed frigates in line ahead when it was taken, but now shows ocean escorts, with a famous U-boat killer of the Second World War, HMCS *Swansea*, in the foreground. (CCC9-113)

Negative numbers of RCN photographs reproduced in *The Crowsnest* are included with the caption for the benefit of persons wishing to obtain prints of the photos.

This they may do by sending an order to the Secretary Defence Staff, Canadian Forces Headquarters, Ottawa, quoting the negative number of the photograph, giving the size and finish required, and enclosing a money order for the full amount, payable to the Receiver General of Canada.

Sizes, finish and the National Defence standardized prices, follow:

4 x 5 (or smaller) glossy finish only ..	\$.10
6½ x 8½ glossy finish only40
8 x 10 glossy or matte finish50
11 x 14 matte finish only	1.00
16 x 20 " " "	3.00
20 x 24 " " "	4.00
30 x 40 " " "	8.00

SUBSCRIPTION RATE

The Crowsnest may be subscribed for at the rate of \$2 a year; outside of North America, \$3. Orders, accompanied by cheque or money orders payable to the Receiver General of Canada, should be sent to:

THE QUEEN'S PRINTER,
OTTAWA, Ontario,
Canada

Communications, other than those relating to subscriptions, should be addressed to:

EDITOR,
The Crowsnest,
Canadian Forces Headquarters,
OTTAWA, Ontario.

The Cover—They do the most interesting things around the Naval Research Establishment at Dartmouth. For instance, some Haligonians, viewing the above scene on Bedford Basin, might have concluded their fair city was under attack from a Polaris-type submarine. Not so. What really was going on is explained in the Science and the Navy section of this issue.—NRE Photo by W. R. Carty.



RCN NEWS REVIEW

Fifty years ago, in October 1914, the first troop convoy of the First World War assembled in Gaspé Bay—31 transports carrying 321,779 soldiers to the battlefields of Europe. In contrast, ocean escorts of the Seventh Canadian Escort Squadron cruised Gaspé Bay this past summer on peace-time training and gave sea cadets of the Gaspé area a day at sea. Moving up to take station on the Fort Erie are the Inch Arran and New Waterford. (Cassidy Photo, Gaspé Que.)

Exercises Occupy Atlantic Forces

Surface ships, submarines and aircraft of the Marine Command Atlantic were occupied for most of September with anti-submarine exercises in the Western Atlantic.

The first exercise, under NATO auspices, had MARLANT forces operating with the U.S. Strike Fleet before it joined an overseas NATO exercise entitled "Teamwork". The Canadian-U.S. exercise was carried out from Sept. 2 to 13.

The Canadian units then formed up with other U.S. forces for another anti-submarine exercise in the Western Atlantic.

Anti-submarine warfare ships and aircraft from East Coast Canadian bases and from United States bases from Argentina to the Caribbean, as well as U.S. Coast Guard, U.S. Naval Reserve and certain U.S. Air Force units from the East Coast participated in late September under the operational control of ASW Commanders.

The ASW forces were opposed by U.S. and Canadian-based "enemy" submarines.

The operation was designed to exercise the Canadian and United States ASW command control organization and facilities and their operating forces in simultaneous operations over a large

Her Majesty Sends Thanks

Her Majesty the Queen on Oct. 13 sent a message to His Excellency the Governor General in which she expressed sincere appreciation for the admirable arrangements made for her Canadian visit.

"I would like you to extend my congratulations to all units and to individual officers, men and civilians under your command who were associated with it," Hon. Paul Hellyer, Minister of National Defence, said in a message to Canadian Forces Headquarters. "Well done, all of you."

The Royal Canadian Navy's participation in the early October Royal Visit included the provision of four warships as escorts to HM Yacht *Britannia* from the Gulf of St. Lawrence to Summerside, P.E.I., from there to Charlottetown and thence to Quebec City. The ships were the destroyer escorts *Assiniboine*, *Nipigon*, *St. Laurent* and *Yukon*, of the First Canadian Escort Squadron.

The RCN also contributed toward security arrangements by providing clearance divers to assure the safety of the Royal Yacht.

geographic area. It also sought to improve the ASW readiness of Canadian and United States forces, including U.S. Naval Reserve, U.S. Coast Guard and certain U.S. Air Force Units.

The two-week exercise, in which almost 100 ships and nearly 300 aircraft participated was conducted by Commander Anti-Submarine Warfare Forces, U.S. Atlantic Fleet, Vice-Admiral Charles E. Weakley, USN, and Canadian Maritime Commander Atlantic, Rear-Admiral J. V. Brock, RCN.

Canadian forces included the destroyer escorts *Algonquin*, *Athabaskan*, *Crescent*, *St. Laurent* and *Yukon*, with the ocean escorts *Cape de la Madeleine*, *La Hulloise* and *Outremont*, and the Halifax-based British submarines *Auriga* and *Alcide*.

Canadian air units were 404 and 405 RCAF Maritime Squadrons from Station Greenwood, and 415 RCAF Squadron from Station Summerside, along with VS 880, naval air squadron based at *Shearwater*.

Hurricane Gladys halted the exercise 24 hours ahead of schedule and cancelled the subsequent visit to Halifax of the USS *Essex* (aircraft carrier) and USS *Stickell* and *Richard E. Hart* (destroyers) which was to begin Sept. 25.

However, Vice-Admiral Weakley sent a message to the Canadian forces which had taken part, as follows:

"Indications are that (it) has been a very profitable exercise for all concerned and has again proven the compatibility of our forces. I would like to take this opportunity to express my sincere appreciation for the Canadian forces' participation and the outstanding professionalism displayed by the personnel of all ranks. The smooth implementation of the operation order and quick response to changing situations during the exercise demonstrates the

high calibre training and readiness of your forces and is most reassuring. Please convey my congratulations to all for a job well done. Vice-Admiral Weakley."

Incentive Award Plan Announced

Suggestion awards have been grouped with a number of new awards for members of the public service under a comprehensive Incentive Award Plan.

The new plan offers greater benefits to employees in recognition not only

of proposals for increased economy and efficiency, but also for improved service to the public, long service and outstanding achievements.

Suggestions which result in monetary savings, increased efficiency or improved working conditions will continue to be recognized by the granting of a certificate of merit and a suitable award in kind or cash, depending on the value of the suggestions to the public services. Suggestion awards are open only to employees whose duties are not above the level of junior management.

A new plan is the "Merit Award",

A Statement by the Minister

HEADQUARTERS REORGANIZATION

The following statement was made by Hon. Paul Hellyer, Minister of National Defence, on Oct. 6:

In the *White Paper on Defence*, it was stated that "the present headquarters organization of the Department of National Defence is far too large. The fact that our field forces are modest creates a serious unbalance between the field and headquarters branches of the service. As it appears that we will have to maintain modest forces in being for many years to come, it is apparent that a reorganization is required."

The *White Paper* went on to state that the solution was considered to be "the integration of the Armed Forces of Canada under a single Chief of Defence Staff and a single Defence Staff. This will be the first step toward a single unified defence force for Canada."

Subsequently, by Bill C-90, this integration of the Canadian Forces Headquarters became effective on Aug. 1, 1964. Since that time, the Chief of Defence Staff, and his senior staff officers have been developing their plans for the complete reorganization and integration of the headquarters on functional lines.

The plans for the reorganization of Canadian Forces Headquarters are already well advanced and it is now possible to identify some of the significant reductions which will be made in the numbers of personnel. There is a reasonable prospect that something in the area of 1,000 military positions, which represents approximately 30 per cent of the Canadian Forces Headquarters, can be eliminated.

In order that an orderly and progressive rundown of strength between now and the summer of 1965 can be achieved, a certain flexibility has been allowed the Defence Staff to work towards the final reduced strength over the year ahead.

At the time Bill C-90 became law, the numbers of officers of the rank of major-general and above in the authorized establishment at Canadian Forces Headquarters was reduced from 17 to 12.

This statement concerns the next phase of the reduction which encompasses the ranks from brigadier down to major. In achieving this rundown two factors will be effective. Officers and men will be leaving the Armed Forces on reaching compulsory retirement age. This factor in itself will look after a sizeable proportion of the reduction. In order to obtain the full reduction required in a reasonable length of time and to maintain an adequate flow of promotion in all ranks of the services, the special gratuity plan was authorized to give those prematurely retired a cash benefit to assist them to rehabilitate themselves.

The officers receiving releases will be advised privately by letter. The first letters will go out from Ottawa about Nov. 1, 1964, the next group about Feb. 1, 1965, and the third about May 1, 1965. All of the personnel concerned will receive a minimum of three months' notice of their retirement. Although the reductions in establishments are being made in Canadian Forces Headquarters, the officers who will be prematurely retired may, at present be occupying appointments elsewhere in the Armed Forces.

The approximate number of premature releases which will be made between Nov. 1, 1964, and the summer of 1965 will be as follows:

Brigadier or equivalent	- up to 7
Colonel or equivalent	- up to 15
Lt.-Colonel or equivalent	- up to 40
Major or equivalent	- up to 60

The planning for reductions in officer ranks of captain and below and for other ranks has not yet been completed, but the indications are that relatively few personnel in these rank levels will be released prematurely up to July 1965.

I would here like to re-emphasize that there is no question as to the loyalty, efficiency and faithful service of those who will be affected.

At the same time as these cutbacks are being made, it is essential for the future of the Armed Forces that a reasonable flow of promotions be maintained. The plan which has been devised recognizes this and ensures that good careers will continue to be available to those who remain in the Services.

It is equally essential for the future that the Armed Forces obtain the numbers of recruits, both officer cadets and men that they require to sustain the Services. Even though cutbacks are being made, the Navy, Army and Air Force have a pressing need for recruits today and will continue to offer young men challenging and satisfying careers. One of the objectives of the reductions is to make funds available for new equipment. It is the recruits of today who will be trained to operate and maintain this new equipment the Armed Forces will be getting.

which makes it possible for management to recognize employees at any level for performance or contributions of unusual merit to the operations of a department or improved service to the public. Awards up to \$1,000 in cash, together with a citation, may be granted under this plan.

Also new is the "Long Service Award", given in recognition of 25 years' service and involving the presentation of a pin or brooch. Some government departments give tokens of appreciation for long service but these apply only to employees who have spent all or a considerable part of their service in the department granting the token. The new award will apply to any public servant who has completed 25 years of service, regardless of his length of time with any one department.

Heading the list of awards under the Incentive Award Plan is the "Outstanding Achievement Award", consisting of a citation and a cash grant of \$5,000. This may be granted to a person in any department or agency of the Government of Canada during the course of his career for outstanding service to Canada.

Convoy Exercises In East Atlantic

NATO's large-scale naval exercise, Team Work, ended October 2 and some 35,000 men and women, 160 ships and 170 aircraft from seven allied nations headed back to their normal jobs.

Team Work was the largest NATO sea exercise since 1960. The operation was under the joint command of Admiral H. P. Smith, USN, Supreme Allied Commander Atlantic (SACLANT), in Norfolk, Va., and Admiral Sir Wilfrid Woods, RN, Allied Commander in Chief Channel (CINCHAN), in Portsmouth, England.

Research Ship Launched Sept. 4

The marine physics research vessel *Endeavour*, which is being built by the RCN for the Pacific Naval Laboratory at Esquimalt, was launched on Sept. 4 at Yarrow's Ltd., Esquimalt.

Sponsor of the ship was Mrs. A. H. Zimmermann, wife of the chairman of the Defence Research Board, of which the PNL is a unit.

The 235-foot vessel will enter service early in 1965 as CNAV *Endeavour*. She features a bulbous bow to reduce pitch, stabilization tanks to counteract roll, a helicopter flight deck and telescopic hangar, and an array of deck gear for handling scientific instruments.



Here on board HM Royal Yacht Britannia are the six members of the RCN chosen to serve during the Britannia's voyage to Newfoundland with the Princess Royal in September and the subsequent visit to Prince Edward Island and journey to Quebec City in conjunction with the Royal Tour of Her Majesty the Queen and His Royal Highness the Prince Philip. In the front row are Ldg. Sea. Earl Pederson, Lt. R. S. Binnie and Ldg. Sea. Harry Ruppel. Back row: AB Roland Robitaille, AB Abbie Eddy, Ldg. Sea. John Gormely and Ldg. Sea. Ivor McLeod. (Royal Naval Official Photograph)

Annual Award For Safe Drivers

An annual safe driver award is being initiated by Canadian Forces Headquarters for Department of National Defence drivers.

The first award will be based on driving records from Jan. 1, 1948, to Dec. 31, 1964. Subsequent awards will be based on the calendar year.

Every Department of National Defence employee whose regular daily duties include driving a DND vehicle and who drives for a complete calendar year without being involved in a preventable vehicle accident is eligible to earn the safe driver award.

The closing date for receipt of safe-driving records for DND driving for the first award was Oct. 13.

Three Tribals Bought for Scrap

The Tribal class destroyers *Cayuga*, *Micmac* and *Nootka*, which were paid off for surplus last winter, have been bought by the Port Colborne, Ont., Marine Salvage Ltd., the firm announced in September. They will be towed from Sydney, N.S., and broken up for scrap in Scotland.

The salvage firm, situated on the Welland Canal, acts as ship buyer, broker and breaker.

The three Tribals were built by Halifax Shipyards Ltd. and joined the fleet in the immediate postwar years. They were paid off at Halifax early this year.

Margaree Next For Conversion

The St. Laurent class destroyer escort *Margaree* was taken in hand in mid-September by the Victoria Machinery Depot, Victoria, for a 13-month conversion program.

As in the case of earlier St. Laurent conversions this will involve the installation of a helicopter landing platform and hangar, stabilizers and variable depth sonar.

Three Ships off For Britain

Three destroyer escorts of the Fifth Canadian Escort Squadron left Halifax Sept. 25 for a training cruise in British waters.

HMC Ships *Kootenay*, *Chaudiere*, and *Terra Nova* were under the overall command of Captain D. L. MacKnight, Commander Fifth Escort Squadron, who sailed on board the *Kootenay*.

The ships were to visit ports in Great Britain and return to Halifax in early November.

HAIDA GOES HOME



This is HMCS Haida's last ship's company—the volunteer group of reservists from York, the Toronto naval division, who manned her while she was under tow from Sorel, Que., to Toronto.

The story of the organization of Haida, Inc., to preserve for posterity one of Canada's most famous fighting ships was related in the September issue of The Crownsnest by Lt. Peter Ward, RCNR, who is military editor of The Telegram, Toronto.

The previous article told of the arrival of HMCS Haida in Toronto, her reception there and the plans for her future. Now Lt. Ward retraces his steps a bit and tells the story of the Haida's last journey from Sorel, Que., up the Seaway to Toronto. Here's the way it went:

THE VOLUNTEER CREW for the last cruise of the *Haida* assembled at HMCS York, the Toronto naval division, just before 2100, Aug. 21. We looked more like a marine camping expedition than a destroyer's crew.

Special duty for 18 officers and men had been authorized so the York sailors could man HMCS *Haida* as she was towed through the Seaway, the length of Lake Ontario, to her last berth in Toronto. The *Haida* left the navy a few months earlier, and had been sold to

a group of sentimental Toronto men who are turning her into a memorial museum.

The *Haida's* last crew was to board the ship at Sorel. There would be no power on board, so naphtha gas cooking stoves and coal-oil lamps were rig of the day for the pick-up crew.

A navy truck took sailors and gear to Toronto's Union Station where sailors lent baggage men a hand loading equipment onto the train. Lt.-Cdr. Jack MacQuarrie was a late arrival. He

pulled up in front of the station less than half an hour before train time with two-way radios, a tool kit, diving gear, and a 400-pound gasoline generator.

As Lt.-Cdr. MacQuarrie's half ton of equipment was carried to the train baggage car, the air was blue with *sotto voce* profanity. We'd thought of trying to smuggle most of our gear onto the train as hand baggage, but it's impossible to convince even the most gullible sleeping car porter that a 400-pound gasoline generator is part and parcel of your portable luggage—necessary for your morning toilet. We may have cursed while loading the paraphernalia, but without Lt.-Cdr. MacQuarrie's generator and bag of tricks, we would have a much less comfortable trip and might have run into serious trouble.

Our coach of the Toronto-Montreal train looked like a Second World War draft train heading for Halifax that night. We sat up discussing the prob-

lems ahead until the small hours, then tumbled into berths for a few hours sleep before Montreal.

A navy bus met the train and, after some delay in getting our "hand baggage" sprung from the depths of the terminal, we loaded everything aboard, and headed off into the Montreal rush hour.

We took the road along the south shore of the St. Lawrence and made the 50-mile trip to Sorel with only one stop for breakfast. Some of the York reservists discovered French isn't as easy as the textbooks say. More than one man ordered bacon and eggs, then wound up with sausages and pancakes.

The *Haida* was there at the Department of Transport jetty, snuggled in behind the huge navy tug which brought her from Halifax. An armed RCN guard turned over the ship, and the *Haida* was civilian property.

Lt.-Cdr. Bill Wilson, York's executive officer and skipper of the *Haida* for her last trip, made a quick round of the ship. We discovered the absence of a few vital things—like heaving lines—and quickly scrounged them from the RCN tug before she departed. PO Bill Lloyd, shipwright by trade, was appointed cook and dispatched to the local stores to buy rations for us. Lt.-Cdr. MacQuarrie also left for a shopping spree—buying gasoline, coal-oil, batteries, etc.

The two tugs from McAllister Towing Co. which were to tow the *Haida* through the seven Seaway docks, then on through Lake Ontario to Toronto, arrived shortly after noon.

With a great snorting and groaning, an air compressor was hoisted on board the *Haida* and lashed down just abaft "A" gun. The compressor was hooked to the capstan and gingerly conducted experiments proved that the air pressure developed was just enough to rotate both capstans. With this power we could heave in just about anything, but very slowly.

The two-way pocket radios Lt.-Cdr. MacQuarrie had borrowed from Motorola for the trip were tested from both tugs and from all positions on board the *Haida*. They worked, and we had an operational communications network. The RCN from Montreal had supplied hammock mattresses and one blanket and pillow per man. We staked out our own personal corners of the ship. PO Lloyd arrived back on board with more groceries than an orphanage cook who'd been given *carte-blanche* in the supermarket. He set up his naphtha stoves in the wardroom galley where we had decided all the ship's cooking would be done.

Lt.-Cdr. MacQuarrie appeared back at the ship, preceded by a truck with gasoline and coal-oil to lighten our darkness.

We slipped lines from the Sorel jetty and got underway at 1500.

We had anticipated the fresh water problem that would face our pick-up crew in the unpowered *Haida*. Plastic containers bought in the discount stores of Sorel were to be the answer. Trouble was, we could only buy two or three of them, and this obviously wouldn't be enough to supply us for the full trip. Petty Officer Lloyd had an inspiration. We commandeered the captain's bathtub.

The stern tug fed a fresh-water line onto the quarterdeck and half a dozen hands were drafted as a bucket brigade. As fresh water shot on board via the tug's high-pressure hose, we filled bucket after bucket and ran them back to the captain's day cabin, filling until there was just an inch or so between the bathtub's rim and a full scale flood. Then we filled all the buckets one last time and set them among the pots and pans in Petty Officer Lloyd's galley. From that galley came a healthy batch of sandwiches soon after we slipped; then we settled down for a complete survey of the ship.

Each gun mount had been doctored so it wouldn't function as a gun again, but this was just what *Haida Inc.*, new owners of the ship, wanted. Imagine the consternation some energetic 12-year-old could create by suddenly training a gun through a crowd of tourists touring the ship, sweeping them all over the side.

The gear from all radar and radio spaces had been removed, leaving just the shell, but *Haida, Inc.* has plans to restore those compartments. Considering the ship had been in Class C reserve for nearly a year, she was in remarkably good condition. Thanks for this are due in no small measure to the RCN personnel who worked over the *Haida* in that last week or so before she left the East Coast for the last time.

Being an electrical officer, Lt.-Cdr. MacQuarrie was disturbed by the fact that we had no power in the ship, but miles of perfectly good wiring. Trouble was all ship's bulbs, motors, etc. were 220 volts, and the generator we'd sweated to get on board put out 110-volt current. Our enterprising electrical officer pondered this problem in every spare minute, then shortly after dark he drafted half a dozen off-watch volunteers and began work.

The emergency wiring cable in each compartment was connected. We managed to find several neon light bulbs left on board by some forgotten mess. The generator was gassed up and started, connected to the maze of extension cords and emergency wiring



The tugs arrive at Sorel to take the *Haida* under tow.



What the deckhand knows is that tying up and letting go is the curse of the *Seaway*. Here, the *Haida's* reservist crew learns about hawsers.

which now laced the ship. Then, suddenly there was light. We had brought a few 110-volt light bulbs with us, and with these Lt.-Cdr. MacQuarrie and his crew managed to light the spaces of the ship we were using. All that energy must have had something to do with the fabulous steak dinner that PO "Mother" Lloyd provided from the galley late that first night.

We all went to bed (except those on watch) to slumber blissfully through about three hours before we hit the first seaway lock, just west of Montreal.

Locks . . . We thought we'd never see an end to them. With four officers and 14 men, imagine trying to handle two three-inch hawsers forward, and two more after at the same time. It didn't matter what you wore on your collar or sleeve, when we came to a lock you tailed onto a line and pulled.

You were lucky if it was your watch when the ship came to a lock, because all hands were required. If you were off watch . . . too bad. Trouble was, none of us had been real practising sailors for quite some time. Some of us never had. We were so hard up for staff that the crew's junior public relations officer was told off to be quarterdeck

officer and that's quite a job when shipping through those seven Seaway locks. But for the kind offices of a very competent chief petty officer, that type-writer specialist might still be off somewhere in a corner mumbling about springs and breasts.

Days ran into nights as we slipped through lock after lock on the *Seaway*.

Sunday morning, fog closed around the two tugs and the *Haida*. We could only dimly see the shoreline of the St. Lawrence. We didn't have the faintest idea where we were. The tugs found their two-way radios a mixed blessing, because there were a lot of questions we wanted answered that just didn't seem that important to a seasoned river man. The tugs turned on their radios when they had something to say to us, but asking them a question was a difficult matter. We had tried in Toronto to buy charts of the *Seaway* without success. The RCN didn't have any *Seaway* charts they could spare, and there were none to be had at HMCS *York*.

Picture then, Lt.-Cdr. Wilson, anxious like the rest of us, to find out how far along we were, leaning over the quarterdeck rail with an Esso road map in his hand, hailing a passing outboard motorboat with the plaintive request: "Where are we?"

Soon the fog closed down and the tugs were forced to anchor. Lt.-Cdr. Wilson, a pipe smoker even while sound asleep, leaned over the rail to pass a radio to the forward tug. Plop. He lost the bowl of his pipe over the side. Loosened by years of hard pulling, bowl and stem of the pipe parted in answer to the law of gravity. It was the only pipe Lt.-Cdr. Wilson had with him. Another panic call went to a passing motorboat. The pleasure-boaters retrieved the pipe bowl and we lowered a bucket to bring it back on board.

Just as the pipe saga was coming to a successful close, one of the officers coming up for watch appeared. He spotted the fog; spotted the fact that we were anchored; and saw the relief of Lt.-Cdr. Wilson's face as his pipe bowl came back on board.

"You've got your pipe back," he said. "Is it okay if we get under way again?"

For a minute there was silence. Then came the laughter.

Later on Sunday, the last of the locks behind us, we began making plans for the ship's arrival in Toronto. The RCN had put five cases of signal flags on board. We did a practice dress ship, with the sun streaming down and the ship surrounded by hundreds of pleasure craft from yacht clubs from both sides of the river. They followed us, some of them for several hours, asking

questions, waving, and offering good wishes as they finally sped away.

Two of our crew, required back in the city by Sunday night, left the ship at the Ivy Lea Bridge by one of those pleasure boats. Later that night, just off the city of Kingston, a pilot boat took four more of our meagre crew ashore because they were required for Monday morning jobs. Among others, we lost our cook, PO Lloyd, so PO John Waddell agreed to take over. He'd done sterling duty earlier in the trip, making some of the plumbing serviceable.

We hit Lake Ontario right in the teeth of a strong blow from the west. One of the tugs departed, leaving us at the end of about 300 yards of nylon tow rope, pitching a bit in the fresh water swell.

Lt.-Cdr. MacQuarrie got to work again. He was sure we could extend the power lines further and get more mileage from our generator. We'd been using oil lamps for port and starboard running lights till then. Lt.-Cdr. MacQuarrie was convinced the lights could be put in working order. He checked the bulbs, but the filaments were broken. Carefully he removed the glass, kidnapped two 230-volt bulbs from elsewhere in the ship, soldered wires to them, and in some fashion rigged the running lights to work. It involved converting the voltage of the current, as well as manufacturing his own light bulbs. The *Haida* finished her career afloat as the only ship in the fleet with

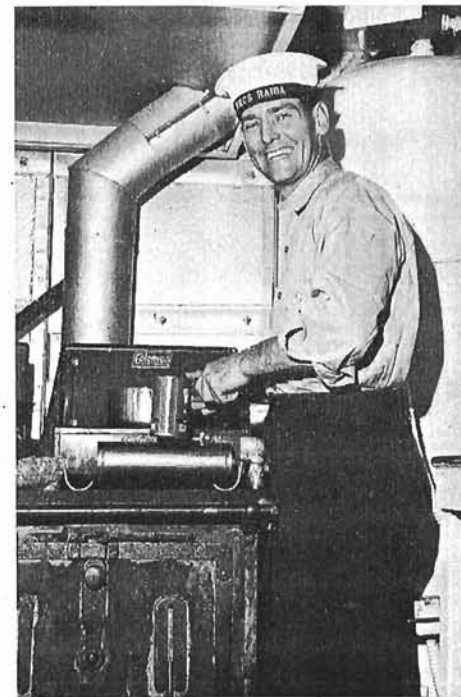

A shipwright is a handy man to have on board, especially if he can cook. PO Bill Lloyd takes charge of the galley on the *Haida's* last voyage.

frosted glass running lights. Lt.-Cdr. MacQuarrie and his electrical whiz-kids weren't finished yet. Before the *Haida* arrived in Toronto he'd converted the current and powered the port 10-inch projector so we could signal the tug when we wanted to talk to them.

Incidentally, we hoped we might pass within sight of HMCS *Lanark*, at the time cruising that part of Lake Ontario. It would have been worth a great deal to signal *Lanark* . . . "What ship?"

At one point during the electrical gymnastics of Lt.-Cdr. MacQuarrie, he was seen by Lt.-Cdr. Wilson walking down the deck with a huge spanner over one shoulder.

"Are you the plumber now, MacQuarrie?" asked Lt.-Cdr. Wilson.

"No sir," replied MacQuarrie. "The plumber's in the galley cooking supper."

It was that kind of a trip.

During that last day in Lake Ontario, the sun shone, but the wind made it

cold. We accomplished a fair bit of work, cleaning the ship and making things relatively shipshape for her Toronto arrival. As dusk fell, we could see the lights of Toronto far to the northwest. Originally the ship was scheduled to arrive in Toronto late Monday afternoon, but those strong west winds had held us up, and the *Haida* was still several hours from Toronto when we watched the Canadian National Exhibition fireworks light up the sky about 2300.

We rounded Toronto Island and dropped anchor for the night shortly before 0200 Tuesday. It was the only chance we had to use the 10-inch signal projector Lt.-Cdr. MacQuarrie had connected. When the tug *Youville* from HMCS *York* came out to meet us, we dazzled 'em with the regulation naval challenge, but they didn't have anything to answer us with.

The *Haida's* official entry into Toronto was staged at 1000 Aug. 25. The tug from HMCS *York* brought a boatload of TV and radio men out to the ship and they spent a happy hour shooting film and taping tape. Then Toronto's fireboat, the *William Lyon Mackenzie*, came out to meet us. So did a fair-sized contingent of small pleasure craft and a Coast Guard cutter.

We were towed in through the western gap with the cutter and fireboat both spraying jets of water into the air. Horns and whistles tooted all over the harbour. Ensigns dipped as boats and ships saluted the *Haida*, and finally, we got lines ashore and tied her up.

The *Haida* had finished her last voyage and, navy men being the sentimental slobs they are, there weren't too many eyes completely free of mist. Bringing the Grand Old Girl to her last resting place was an honour it will be hard to equal.



Eighteen young RCN Short Service Plan officer cadets graduated Saturday, Sept. 26, from HMCS *Venture*, officer training establishment at Esquimalt. The ceremony marked the end of 13 months of training in naval and academic subjects for the cadets, who have been promoted to Acting sub-lieutenants and appointed to ships and establishments or to aviation training with the RCAF. The cadets are shown being inspected by Captain F. C. Frewer, Chief of Staff to the Flag Officer Pacific Coast. (E-78256)

OFFICERS AND MEN

Former XO Commands Sub

Lt.-Cdr. John Rodocanachi took command of HMCS *Grilse* in September, succeeding Lt.-Cdr. George McMorris.

Lt.-Cdr. Rodocanachi was born in Suffolk, England and served in the Royal Navy for 10 years during which he was associated with the basing of the Royal Navy's Sixth Submarine Division in Halifax, in the early 1950s.

He transferred to the RCN in 1957, serving initially in the aircraft carrier *Bonaventure* and then at the Joint RCN-RCAF Maritime Warfare School in Halifax.

He had been executive officer of the *Grilse* since May 1961.

Unicorn Wrens Tops for Canada

The wrens' division of HMCS *Unicorn*, Saskatoon naval division, has won the Tait trophy for proficiency in competition with women naval reservists across Canada. The divisional officer is Lt. Helen Hues.

The trophy was presented for competition by Lt.-Cdr. Fanta Tait, RCN, former Staff Officer (Wrens), on the staff of the Commanding Officer Naval Divisions, at the time of her retirement and this was the first year of competition.

The trophy was presented to Lt. Hues on a recent training night at *Unicorn* by Lt.-Cdr. E. C. Boychuk, commanding officer of the division.

Judging for the award was based on the wren division complement, attendance at drills, percentage attendance, participation in activities of the wrens' mess and ship's company and general appearance and deportment at annual inspection.

Awards Made to SSOP Graduates

The top award winner in the first graduating class of the RCN Short Service Officer Plan was Acting Sub-Lt. W. J. Rupka, of Burlington, Ont., Captain F. C. Frewer, Chief of Staff to the Flag Officer Pacific Coast, presented him with the Department of National



Major General L. G. C. Lilley, Deputy Chief of Logistics, Engineering and Development in the integrated Canadian Forces Headquarters, Ottawa, during a recent inspection and familiarization tour of military establishments in the Halifax-Dartmouth area. Shown with Major General Lilley, from the left, are Cdr. J. K. Power, officer-in-charge, Naval Supply Depot, Halifax, and Lt. T. G. Craft, Supply Corps, USN, planning officer, NSD Halifax and briefing officer. Behind them are Rear-Admiral J. B. Caldwell, Chief of Naval Technical Services, and George Burton, supervisor, Data Processing Centre, Halifax. (HS-76106)

Defence naval officer's sword for obtaining the highest standing in officer-like qualities and professional subjects.

Captain Frewer presented the Hampton Grey shield to Acting Sub-Lt. M. A. Deneau, of Shannon Park, N.S., for being the graduate outstanding in athletic ability and sportsmanship. The Rowland cup, another sportsmanship trophy which the cadets award, went to Acting Sub-Lt. M. C. Creighton, of Port Hope, Ont. The presentations were made at HMCS *Venture* in Esquimalt Sept. 26.

The Hampton Gray shield is presented in memory of the late Lt. Hampton Gray, VC, DSC, only member of the Canadian naval forces to win the VC in the Second World War.

Cyclic System's Aims Explained

A pamphlet, *The Cyclic System—What It Means to You*, has been prepared for the information of all serving

members of the RCN and has been distributed to the commands.

The "Cyclic System" is defined as a method of employing ships and men to ensure a fair and efficient distribution of operating, training and maintenance time. It is considered that a major benefit of the system will be "the development of predictable opportunities for early training through the lower trade groups."

Commanding officers have been instructed to see that the pamphlet reaches every officer and man under their command so that there will be a full understanding of the purpose of cyclic employment of ships and men.

Lott Fund Award For Radioman

PO George Hugh Lane, Ottawa, has received a cash award from the Herbert Lott Naval Trust Fund for his achievements while attending a conversion course to the highest trade level of

radioman special in the Royal Canadian Navy at HMCS *Gloucester*, fleet establishment near Ottawa.

He stood first in a class of 14 students on the 44-week course, attaining an average of 89.9 per cent.

The Herbert Lott Trust Fund was set up in 1928 by a British stockbroker of that name. It enables awards to be made to officers and men of Commonwealth navies who have demonstrated a particular skill in their work or achieved high standing in training courses.

PO Lane was born in Great Village, N.S. He entered the Navy in May, 1950, and first joined *Gloucester* that November. He has served in various naval radio stations in Canada and in the ocean escorts *Outremont* and *Fort Erie*.

Missile Frigate Visits Esquimalt

The powerful United States Navy guided missile frigate USS *Richmond K. Turner* (DLG 20) secured alongside "E" Jetty at HMCS *Naden* on Thursday, Oct. 1, on a recreational visit for her crew of 21 officers and 352 enlisted men.

The *Turner*, commanded by Captain Douglas C. Plate, USN, was an impressive sight as she moved slowly through a mist that enshrouded Constance Cove. Adding to her "ready for business" look were four "Terrier" surface-to-air-missiles posed on their launchers fore and aft.

The *Richmond K. Turner* was commissioned at the Philadelphia Naval Shipyard on June 13, 1964, and has subsequently formed a unit of Destroyer Squadron 21, Cruiser-Destroyer Force, U.S. Pacific Fleet, based at San Diego, California. The *Turner* has a displacement of 7,650 tons fully loaded. She is 533 feet in length, has a beam of 53 feet and a navigational draft of 26 feet. Her speed is in excess of 30 knots.

The *Richmond K. Turner* is named for the late Admiral Richmond Kelly Turner, who was Commander, Amphibious Force, South Pacific, during the Second World War.

Cadets Awarded Sports Trophies

Grant division at HMCS *Venture* won two trophies which were presented at the graduation ceremonies for the first group of Short Service Officer Plan cadets late in September at Esquimalt.

The ex-Royal Roads Cadet Club trophy was awarded Grant for being the best division in inter-divisional rugby competition. The Jeune Bros, of Victoria Ltd. trophy for interdivisional



The guided missile frigate of today is a ship the size of a light cruiser. This is USS *Richmond K. Turner* on a recent visit to Esquimalt. (E-78300)



Sikorsky rescue awards were presented recently to three helicopter pilots (left to right) Sub-Lt. B. E. McKay, Lt. D. G. Bauder and Lt. J. A. F. Deslisle, by the commanding officer HMCS *Shearwater*, Captain G. C. Edwards. Sub-Lt. McKay rescued a man who had fallen into the sea from HMCS *Columbia* and Lieutenants Bauder and Deslisle were the pilots of the rescue helicopter which spent eight hours transferring dead and wounded under extremely hazardous conditions from HMS *Celerina* to HMCS *Bonaventure* after a Slick Airways Constellation ditched in the Atlantic in late 1962. (DNS-33776)

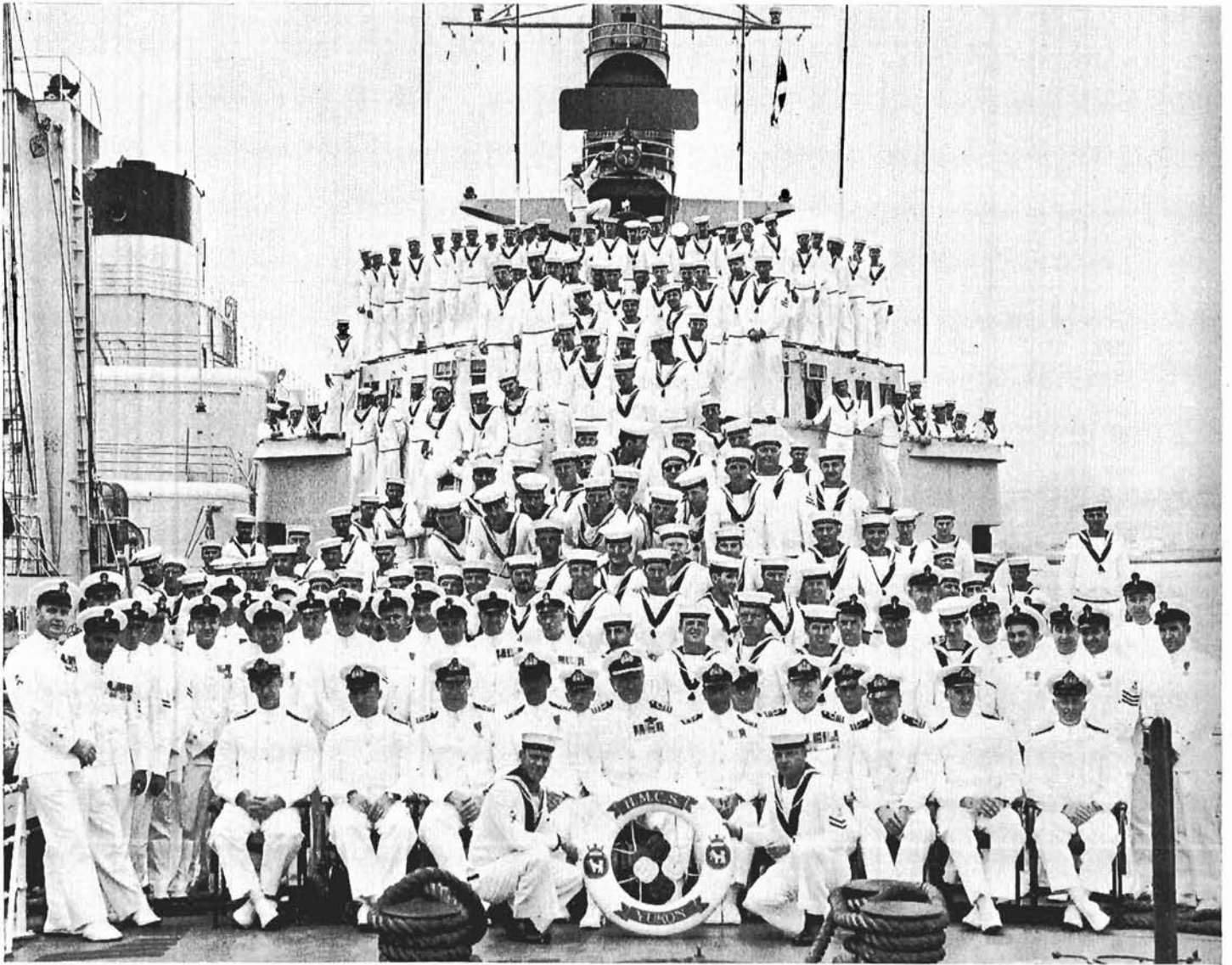

FAMILY PORTRAIT—This group portrait of the officers and men of HMCS Yukon was taken in the sunny Canary Islands in mid-July, when the destroyer escort, in company with HMCS Provider, visited Puerta de la Luz, port of Las Palmas, Gran Canaria. (508-262)

sports and athletics also went to the division. Lt.-Cdr. J. I. Gallant, was divisional officer.

New Commander For RN Submarines

Command of the Sixth Submarine Division of the Royal Navy, based at Halifax, was assumed by Cdr. J. B. Hervey, RN, on Sept. 30. He succeeded Cdr. K. Vause, RN.

Belmont Park Official Dies

Assistant Housing Administrator at Belmont Park, West Coast naval married quarters, Robert George Reid died on Aug. 12.

He enrolled in the RCNVR in Regina on Oct. 7, 1928, and served there until the outbreak of hostilities. He transferred to the RCN on Sept. 6, 1939.

He served at *Naden*, *Givenchy*, *Peregrine* and *Stadacona* and was discharged on Dec. 22, 1945, in HMCS *Queen*. He had attained the rank of chief petty officer.

The funeral took place on Aug. 14 in Victoria, followed by cremation. The committal of the ashes to the sea took place on Friday, Sept. 11 from HMCS *Mackenzie*, the service being conducted by Chaplain J. G. Titus.

He is survived by his widow and one son.

Commodore O'Brien In New Appointment

Commodore John C. O'Brien has taken up the appointment of Senior Canadian Officer Afloat, Atlantic.

He had been Naval Member, Canadian Joint Staff, and Canadian Naval Attaché, Washington, since September 1961.

Born in England in December 1918, he was living in Montreal when he entered the Royal Canadian Navy.

A communications specialist, he served for two years during the Second World War as signals officer with the Fourth Destroyer Flotilla of the Royal Navy. In 1944 he served at the RCN Signal School at Ste. Hyacinthe, Que., and in 1945 became Deputy Director of Signals at Naval Headquarters, Ottawa.

Since the war Commodore O'Brien has commanded the destroyer escort *Crescent* and Communications School in Halifax, and has served on the staff of the Supreme Allied Commander, in Norfolk, Virginia.

He was Director of Naval Training from July 1955 until August 1957, when he became Director of Naval Communications. In September 1959 he was appointed commanding officer of the aircraft carrier *Bonaventure*.

THE BILKO IMAGE

A kind word for the serviceman who is returning to "civvy street" has been said by The Financial Post, of Toronto, which suggests that the early retirement age in the armed forces offers industry a chance to pick up some highly skilled employees. The article, which appeared in the Sept. 2, 1964 issue of The Financial Post, is reproduced herewith.

THAT BILKO IMAGE ISN'T REALLY FAIR

Ex-servicemen's skills too often overlooked, employment experts say.

OTTAWA—Sergeant Bilko and his like are among the worst enemies of ex-servicemen looking for civilian employment.

Too often, worried federal employment experts say, civilian management overlooks those highly skilled arrivals on the labour market because they have been given the impression many peacetime military personnel are too lazy or incompetent to have made the grade outside.

A long series of TV shows and comic strips have added to this notion.

In fact, the Canadian armed forces turned out a steady stream of people industry should jump at, and—after the *White Paper* and its resulting cutbacks—this stream is becoming a near torrent.

If management's attitude doesn't change, Ottawa fears industry as well as the serviceman will suffer needlessly.

It is recognized by officials trying to get these men jobs that both potential employees and employers are going to have to take a new view.

The would-be employee must learn to translate his training and skills into civilian terms. It is no good sitting down with a civilian personnel manager and filling his ear with military initials—"after three years as Obs B at the CGI I switched to ATC". Nor is it necessarily up to the employer to deduce how certain military experience can be useful outside. The job seeker must think that out and make it the heart of his pitch.

All three services maintain Transitional Counselling Groups to advise on this very point.

It is the potential employers, though, who must make the biggest conscious effort if they hope to cash in on this attractive labor market.

These are the main points that should be realized, officials of the National Employment Service say:

The military world has changed dramatically since the Second World War.

This is the computer age and the armed forces have been using the most advanced management techniques. All but the humblest foot-sloggers have had considerable contact with the most modern and advanced equipment both for operational and administrative purposes.

The military's standards may be much higher than you think—or at least very different.

Thus, don't shy away from a man with a medical discharge without closer examination. It may well be that his condition, while ruling him out for active service, more than meets your company requirements.

Nor is it right to presume that the present cutback in military strength is being used as an excuse to trim deadwood. Certainly the services hope to get rid of some less-than-outstanding people this way, but they are also having to retire some first-rate material.

To have reached middle or senior ranks in today's military structure, officers and NCOs have had to show some pretty marked ability.

For example, take the supply branch of the navy:

1—The Commodore, as Supply-Officer-in-Chief, the executive responsibility for making sure the right equip-

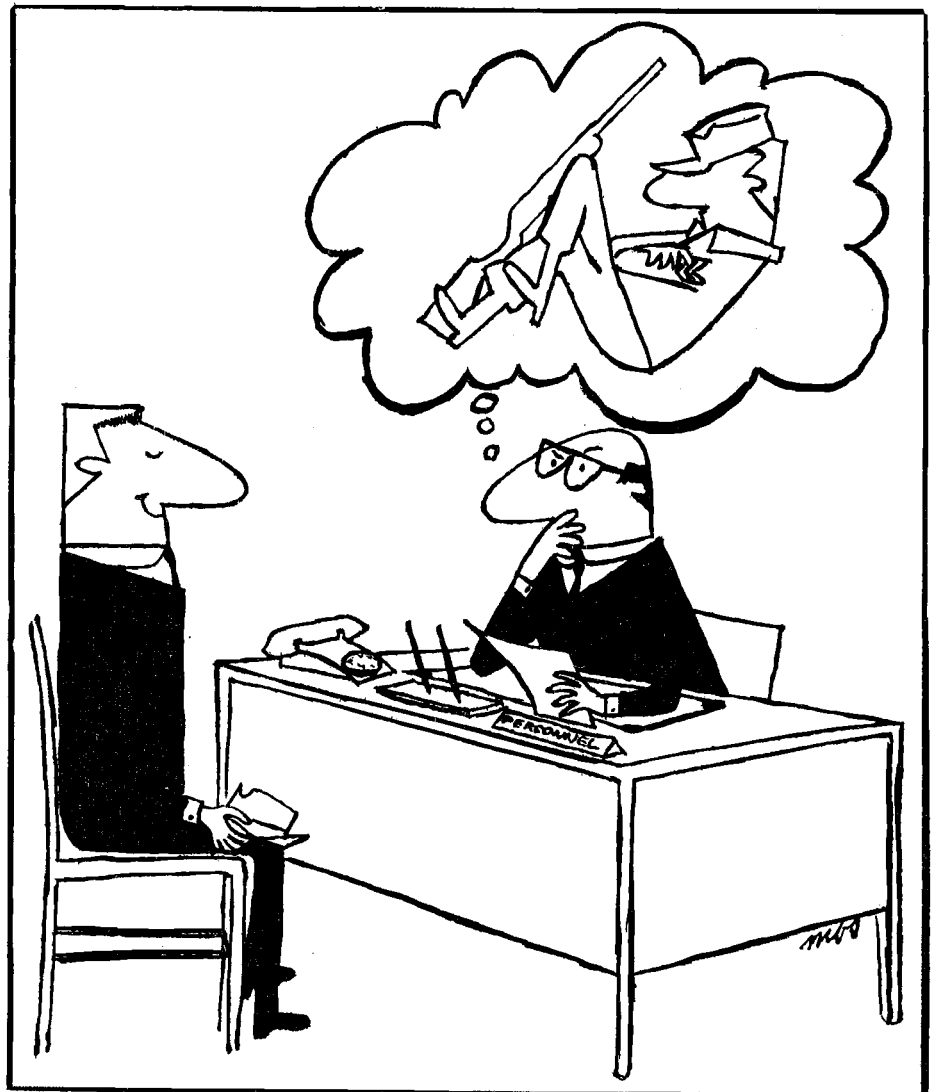

ment, food, fuels, etc. get to more than 100 separate establishments and their 20,000 personnel. This is a management role as taxing as any in civilian life.

2—The Commander, who is supply officer in a big ship or shore station, may have a staff of 300, may handle an annual flow of cash reaching nearly \$4 million, more than 25,000 items in store and the responsibility for feeding 1,200.

3—A Lieutenant, as supply officer on a smaller ship or shore station, can have a staff of 30, cash flow of more than \$200,000, 15,000 items and more than 130 to feed.

4—A Chief Petty Officer, 2nd Class, as a commissary-man, may plan and direct kitchen and dining-room service to handle 1,000 meals a day and manage living accommodation for 200.

None of these jobs is easy and the peace-time, professional forces won't stand for slipshod work. There are equal managerial requirements in every part of the armed forces today.

There are, almost certainly, a few Sergeant Bilkos scattered through the Canadian military establishments today—as there are in industry. To these men, the forces have proven a comfortable haven and they will be lucky indeed to find its equivalent in the cold hard world outside.

But they are a small, unrepresentative minority. It remains to be seen whether industry recognizes this as the armed forces' cutbacks pick up steam.

MARINES OBSERVE 300TH BIRTHDAY

A RIFLE carried by the United States Marine Corps in the Boxer uprising—the first occasion that they fought alongside the Royal Marines—was presented by General Wallace M. Greene, Commandant of the USMC, to the Commandant General, Royal Marines, General Sir Malcolm Cartwright-Taylor, KCB, in London recently.

Two other rifles, one of each of the two World Wars, were also handed to the Commandant General by General Greene. Another gift on behalf of the United States Marines was a display case containing four hat emblems of the USMC dating from the early nineteenth century. An inscription reads "To Mark an enduring respect and friendship forged throughout the globe in peace and war, and in testimony to the proud heritage that Britain's soldiers of the sea have transmitted to all who glory in the title of Marine".

General Greene attended parades and

other events in London in connection with the 300th anniversary celebrations of the Royal Marines. Admiral Charles D. Griffin, Commander-in-Chief, U.S. Naval Forces in Europe, was present when the presentations were made by General Greene.

In connection with the Tercentary celebrations His Royal Highness the Duke of Edinburgh, Captain General of the Royal Marines, dined with the senior non-commissioned officers of the Corps at Portsmouth, Guildhall at the end of July.

One hundred and eighty-six SNCOs from units and detachments of the Corps at home and overseas and representatives from the Royal Marine Forces Volunteer Reserve were present. There were also guests from the Royal Navy, Army, Royal Air Force and the United States Marine Corps.

For the first time since SNCO's drank the Loyal Toast seated—an honour recently bestowed on the Corps by HM the Queen to mark the 300th anniversary of the formation of the Admiral's Regiment.—*Naval News Summary*



Three century-old cannon balls, fired in anger at the Ahousat Indian Village on the west coast of Vancouver Island 100 years ago by the Royal Navy, have been turned over to the Maritime Museum of B.C. The relics were presented to Lieutenant-Governor G. R. Pearkes for transfer to the museum when he visited Ahousat on board HMCS Margaree. Shown examining the suitably-mounted cannon balls are, left to right, Cdr. J. L. Panabaker, commanding officer of the Margaree, Commodore A. G. Boulton, chairman of the board of trustees of the Maritime Museum, and Col. J. W. D. Symons, director of the museum. One was a mortar shell with its powder charge and had to be deactivated by navy divers before becoming a museum piece. (E-77905)

A Letter from the Queen

WHEN A NAVAL OFFICER has satisfactorily completed the probationary period at the beginning of his service, his sovereign in a personal letter informs him of his appointment to a permanent position. It is written in the style of medieval letters patent and it commits to him (that is called a commission) an office in the service of the Crown. In Canada the letter is signed at the top for the Queen by the Governor-General, her personal representative, and it is countersigned at the end by the Minister of National Defence. It reads like this:

[Signed] Georges P. Vanier

Elizabeth the Second, by the Grace of God, of the United Kingdom, Canada and Her other Realms and Territories, Queen, Head of the Commonwealth, Defender of the Faith.
To Mr. Horatio Nelson

hereby appointed a Sub-Lieutenant in Her Majesty's Canadian Fleet

We, reposing special Trust and Confidence in your loyalty, Courage and Integrity, do by these Presents Constitute and Appoint you a Sub-Lieutenant, Royal Canadian Navy, Willing and Requiring you from time to time to repair on board and to take upon you the Charge and

Command of Sub-Lieutenant in any ship or Establishment to which you may hereafter at any time be duly appointed, or the Charge and Command of any other rank to which you may be promoted or appointed, strictly Charging and Commanding all the Officers and company of the said Ship or Establishment subordinate to you to conduct themselves jointly and severally in their respective employments with all due Respect and Obedience unto you and you likewise to observe and Execute the Queen's Regulations and Orders for the Royal Canadian Navy and such Orders and Instructions as you shall from time to time receive from Naval Headquarters or from your Superior Officers. Hereof nor you nor any of you may fail as you will answer the contrary at your Peril. And for so doing this shall be Your Commission.

Given by Command of His Excellency the Governor-General of Canada this twenty-first day of October 1961 and in the eighth year of Her Majesty's Reign.

[Signed]

Minister of National Defence

With Seniority of

Compared to earlier commissions, this document is drawn in general terms to cover service in any ship and in any rank, although it is customary to issue another parchment when an officer is promoted to rear-admiral.

The earliest English commissions were issued to a few of the great barons when the King wanted to call out his forces. Land was held in return for military service and when the lords received their "commission of array" they mustered their vassals and tenants at the place and time specified to await the king's commands.

The same system applied to the fleet. The *Black Book of the Admiralty* contains an article of the office and duties of admirals that was probably written before 1351 (in the time of King Edward III). An admiral, after receiving his commission, had immediately to appoint his lieutenants, deputies and other officers, who were then to find out what ships and seamen were available in the kingdom. He then requisitioned what vessels he needed, with their mercantile crews, had fore- and after-castles fitted, and sent soldiers aboard to do the fighting. The mariners were required only to navigate the ship.

With the soldiers, a company to each ship, came their captain and lieutenant. Later, when the sailors and fighters had been amalgamated, these two officers were appointed by commission and for many years each was appointed to a particular post in a named ship for a specific cruise. There was no such thing as a permanent rank in the navy. For example, one Thomas Berry, about 1670, was successively: lieutenant, captain, second lieutenant, first lieutenant, captain and master (that is, commander), first lieutenant and captain of various ships. Somewhat earlier (starting in 1660) Sir Robert Holmes was successively captain of several small ships, then commander-in-chief of a detached squadron, captain, rear-admiral of the Red, commander-in-chief of another detached squadron, captain of two third-rate ships of the line in turn and then captain of a first rate.

Between commissions these men were not naval officers, they were civilians. They went to sea as merchant officers, served with the Army, pursued a political career, or found



some other employment. Experience in the wars of the eighteenth century taught the Admiralty the advisability of retaining the services of experienced sea officers. The method adopted for doing this was to pay them half the usual rate when they did not hold an office in a ship. It was at first paid to only a number of the most experienced captains and lieutenants. To determine who should receive half-pay, a list of officers in order of seniority was compiled. It is on this practice that the idea of permanent rank in the service was founded, and the list, first issued in 1700, grew into *The Navy List*.

In 1790, by altering the wording of commissions the Admiralty finally admitted that permanent rank existed. Up to then a lieutenant would be appointed by his commission to be "the

Fourth Lieutenant of His Majesty's Ship *Lion*" or "the First Lieutenant of HMS *Victory*". After 1790 a commission no longer specified that the holder was first or fourth lieutenant of his ship, or whichever he was, but gave his "seniority", the date of his first commission in the rank, in the lower corner. When the officers joined their ship they determined, by their seniority dates, their relative positions in the ship.

The formula "go on board and take upon you the Charge and Command of Captain" had to be taken literally in the days of sail. It meant that the captain, on being appointed to a ship laid up "in ordinary" (that is not in commission), hired a boat, had himself rowed out to the ship and mustered her permanent warrant officers and any hands that might be aboard.

He then had his pennant and the ensign hoisted and read his commission aloud. The ship was then said to be "in commission", and it was the captain's duty, assisted by the lieutenants, who would be appointed after him, and by the warrant officers, to fit the ship out for war and man her. This was no mean task for she would be a hulk with no more than her lower masts standing, and before she could be rigged men had to be found to do the job—by press gang if no other means were available.

It was not until 1860 that it was decided that only one commission would be granted for each rank held. Up to that time, in spite of the fact that the principle of permanent rank was accepted long years before, a new commission was issued each time an officer was appointed to a ship.



Elizabeth the Second, by the Grace of God, of the United Kingdom, Canada and Her other Realms and Territories, Queen, Head of the Commonwealth, Defender of the Faith.

To

hereby appointed

in Her Majesty's Canadian Fleet

We, reposing special Trust and Confidence in your Loyalty, Courage and Integrity, do by these Presents constitute and Appoint you a _____, Royal Canadian Navy, Willing and Requiring you, from time to time, to repair on board, and to take upon you the Charge and Command of _____ in any Ship or Establishment to which you may hereafter, at any time, be duly appointed, or the Charge and Command of any other Rank, to which you may be promoted or appointed, strictly Charging and Commanding all the Officers and Company of the said Ship or Establishment subordinate to you, to conduct themselves jointly and severally in their respective employments with all due Respect and Obedience unto you, and you likewise to observe and execute the Queen's Regulations and Orders for the Royal Canadian Navy, and such Orders and Instructions, as you shall from time to time receive, from Naval Headquarters or from your Superior Officers. Hereof nor you nor any of you may fail, as you will answer the contrary, at your Peril. And for so doing, this shall be Your Commission.

*Given by Command of His Excellency, the Governor General of Canada
this _____ day _____ 19 in the _____ year
of Her Majesty's Reign.*

With Seniority of

Minister of National Defence

Soon after the turn of the century the further change was made so that one commission is effective for all ranks from sub-lieutenant to captain.

When, in 1910, the Canadian and Australian Navies were established, it was intended that their officers should be interchangeable with their opposite numbers in the British service. One of the necessary steps to be taken to ensure this was to word their commissions identically, so that all were appointed "in His Majesty's Fleet". However, because of legislative delay, the King was not for some years in a position to make an Order in Council authorizing the Governor-General of Canada to issue such commissions. At first officers were commissioned "in Our Naval Service of the Dominion of Canada", but in 1912 this was changed to "in His Majesty's Canadian Fleet". After 1920 they read "in His Majesty's Fleet", as originally intended.

A further change came in 1950 in consequence of the passage of the *National Defence Act*. It defined three categories of officers of which one was: "a person who holds Her Majesty's Commission in the Royal Canadian Navy..."—but commissions made no mention of the navy by that name, only of "Her Majesty's Fleet". The relationship between the RCN and other navies of the commonwealth was no longer governed by the agreement of 1911, so it was possible to change the commissions to fit the new act. They now read, as is shown at the beginning of this paper, "in Her Majesty's Canadian Fleet" in the heading and "Royal Canadian Navy" in the body of the letter.

Minor changes had occurred from time to time. The various warrant officers had become commissioned, the purser, surgeon, master and chaplain first. The commissions granted to their successors did not contain the injunction of obedience on subordinates until 1927 when it was inserted in all but the chaplain's. In recent years the boatswain, gunner, carpenter and others have all become commissioned under various titles.

Another change was the abolition of half-pay in 1938 when the Admiralty finally recognized that naval officers were to be employed fulltime. But, being able to start anew in 1910, the RCN had never introduced half-pay. It should be recognized, however, that half-pay was a necessary step in the development of the naval profession.

From first to last of its history, the commission has entrusted an important task to its recipient. He no longer

has to fit out and man his ship with little assistance beyond his own professional and spiritual resources, because the large shore-going organization of the navy is there to help him, but the task is really no lighter. The ship and her company are provided complete (though the captain of a new ship does have the opportunity of overseeing the final stages) but both are far more complex.

In the days of sail, the captain was also the chief engineer: he and the boatswain saw to the setting up of the rigging and staying up of the spars; he and the master navigated and manoeuvred the ship, taking charge of the men handling the canvas in time of storm or battle. Now, to make the job more difficult, the ship's propelling machinery has been placed below hatches and it has to be managed by a specially trained agent, the engineer officer. At the same time many other devices have come aboard—fire control gear, radio,

radar, sonar, all requiring special skills to manage them properly. The captain must control all of them through his officers.

When a young man is first commissioned as a sub-lieutenant, the task entrusted to him is to learn the skills required for leadership and command. His training has given him the technical background—he must learn, on the job, to apply his training to the realities of a ship at sea.

But this is only the material side of the task. An officer who makes himself the master of his specialty, or even of all specialties if that were possible, would not rise far in the service because he would be only half the man required. While an officer must specialize in the junior ranks, he must, while doing so, learn the great profession of the leader. It is the opportunity to enter this apprenticeship that is committed to the sub-lieutenant.—*Naval Historical Section*.

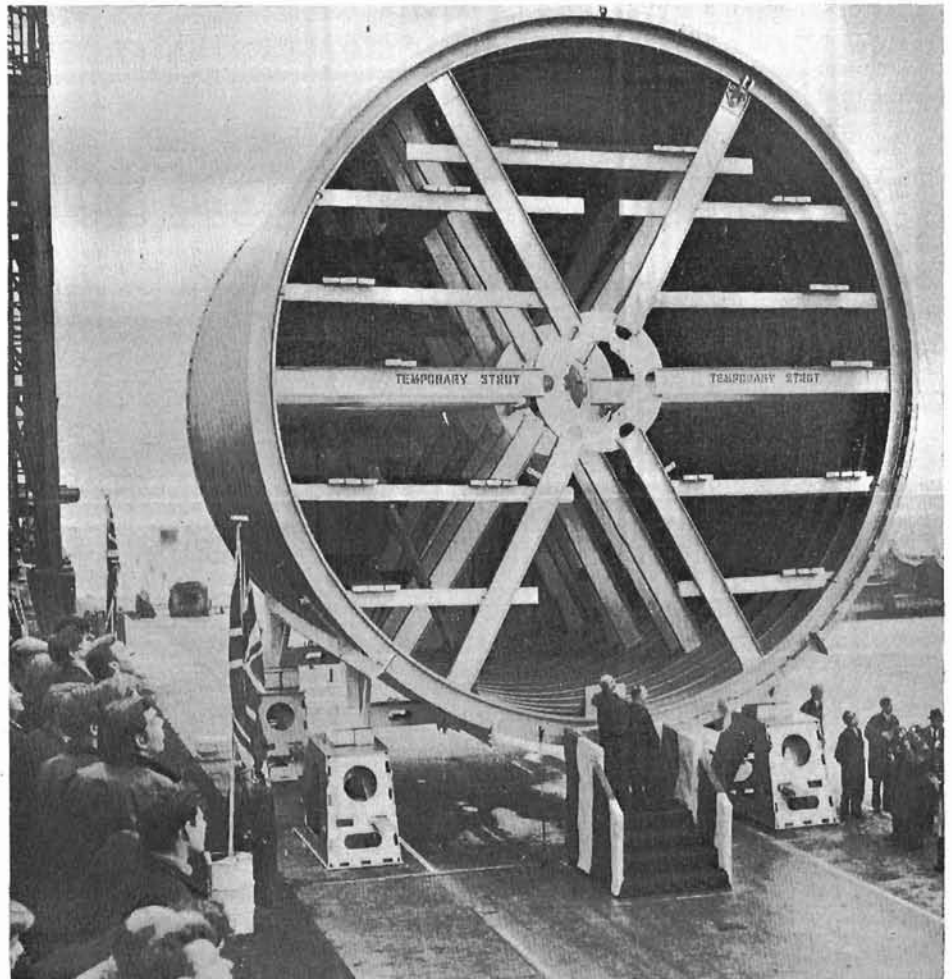

This is a keel? That's what they called it, for ceremonial purposes, when the *Resolution*, Britain's first Polaris submarine, was laid down at a Barrow-in-Furness, England, shipyard, this year. The "keel" consists of a prefabricated section of the submarine and weighs more than 100 tons. The *Resolution* is the first of five nuclear-powered Polaris submarines which Britain intends to build. (British Information Services photo).

AFLOAT AND ASHORE

ATLANTIC COMMAND

HMCS Fort Erie

The *Fort Erie* spent the end of June and most of July on UNTD Cruise Bravo. She sailed from Halifax with the *La Hullose* and *New Waterford* in company and went first to anchor in St. Ann's Bay, Cape Breton Island. After a short stay there for exercises and boatwork she transited the Canso Canal to George Bay for more boat work. The *New Waterford* detached there and proceeded to Summerside, P.E.I., while the *Fort Erie* and *La Hullose* went to Charlottetown.

In Charlottetown members of both ships' companies took part, with the *Stadacona* band, in the Drumhead Service on July 1. The revue "The Best of Spring Thaw" was playing at the new Confederation Centre Theatre. Nearly everyone who wished was able to see the show free of charge. During the week, the officers attended the Lieutenant-Governor's Ball at Government House. *Queen Charlotte*, the naval division, held a dance for the ships' companies.

After the *Fort Erie* left Charlottetown, she spent five days in Northumberland Strait and the Gulf of St. Lawrence doing seamanship exercises and boatwork. She anchored for a day south of Pictou Island and overnight in George Bay. On both occasions parties of cadets were sent ashore with the minimum equipment to spend the night. Both nights were cool but everyone seemed to enjoy the break in routine.

The *Fort Erie* was at Summerside for the start of the Lobster Festival. The stay in this, the largest town in P.E.I., was quiet, except for the parade on Monday in which a 40-man guard took part.

From Summerside, the ship went to Gaspé, Que. This charming town on Gaspé Bay was a naval base during the war and remains navy-conscious and hospitable. Two other ships of the squadron, the *Inch Arran* and *New Waterford*, were there. The *Inch Arran* had replaced the *La Hullose* after Charlottetown. On Saturday afternoon the three ships embarked more than 100 sea cadets and Navy League officials for a short cruise in Gaspé Bay.



"Sure looks tricky, but maybe we can get it after a couple of more lessons." Jim Pender and Charles Sizer, both from Flin Flon, Man., were among more than 1,000 sea cadets who underwent two-week training periods at HMCS Quadra, sea cadet camp near Comox, B.C. The instructor is Lt. Allan Hodgson, RCSC, of Winnipeg. The camp day started at 6 am and ended at 10 pm. In between came sports, sailing, rifle shoots and citizenship training. (E-77575)



Men of three navies met in friendship when USS *Interpreter*, radar picket ship, visited Esquimalt during the presence there of four ships of the Japanese Maritime Self-Defence Force. Ord. Sea. Michael Gracewood, of HMCS *Fraser*, is shown with PO Gerry Collins, of the *Interpreter*, and Chief Machinist's Mate Toshio Takahashi, of JDS *Teruzuki*, flagship of the Japanese training squadron. (E-77954)

While in Gaspé the ships held a squadron regatta. There were 14 races—four sailing and 10 pulling. The final results revealed the closest possible finish. The *New Waterford* won the Cock-of-the-Walk with 40 points while the *Fort Erie* and *Inch Arran* tied for second place with 39 points each.

The ships left Gaspé on July 21 and arrived home in Halifax on July 24. Each of the ships had steamed about 1,000 miles and, singly or together, had visited New Waterford, Charlottetown, Summerside, Alberton, Souris, Dalhousie, Gaspé and Georgetown during the cruise.

RADIO STATIONS

HMCS Aldergrove

Although *Aldergrove* has been commissioned since 1955, until recently she had no ship's bell. Throughout the war years, when *Aldergrove* commenced operation and was known as Aldergrove and Sumas Naval Radio Stations, no ship bore the name. No bell existed to be inherited, as frequently occurs on commissioning.

The deficiency was made up by the utilization of an unnamed bell which had long served the station as a fire alarm. It was inscribed with the ship's name, buffed up and installed in the newly-renovated entrance of the administration building.

Coincident with the installation of the "new" bell was the first christening on board since commissioning. The daughter of the supply officer, Lt. R. R. Godden, was baptized on Sunday, Sept. 20, by Rev. N. Calland, rector of St. Matthew's Anglican Church of Abbotsford, B.C., for 12 years Protestant chaplain to *Aldergrove*.

In accordance with custom, the name of Lynn Godden will be the first inscribed on the bell.

SEA CADETS

RCSCC St. Croix

The first parade of the Lillooet, B.C., sea cadet corps, RCSCC *St. Croix*, was held at the Community Hall in mid-September with 28 sea cadets and eight local officers in attendance.

Visitors for the occasion included Lt.-Cdr. John E. Hobbs, Area Officer Sea Cadets, Pacific Area, and two sea cadet officers from Kamloops, B.C., Lt. Roy Inouye and Sub-Lt. Trevor Stocks, both formerly with the RCN.

The corps was fallen in for inspection by Sub-Lt. T. W. Meagher, executive officer, with Sub-Lieutenants James Ryley and Michael Solecki in charge of the two divisions. The ship's company



The destroyer escort *Margaree* was paid off at the yards of the Victoria Machinery Depot on Sept. 25 and passed into the hands of the shipyard to begin her 15-month conversion. When the *Margaree* rejoins the fleet late next year, she will be equipped with a helicopter landing platform and hangar and with variable depth sonar. Ldg. Sea. Walter Ruffell, who has been with the ship since January 1958, lowers the White Ensign as the *Margaree's* commanding officer, Cdr. J. L. Panabaker, salutes. During her commission, the *Margaree* steamed 202,836 miles, the equivalent of eight times around the world. (E-78246)

was addressed by E. Wilfred West, commanding officer of RCSCC *St. Croix*. Prayers were said by the corps' padres, Rev. John Dunn and Rev. Leonard D. Jenner.

Lt. Inouye extended greetings from the Kamloops corps and expressed the hope there would be visits and friendly competition between Kamloops and Lillooet cadets.

RCSCC John Travers Cornwell, VC

What claims (with figures to prove it) to be the largest sea cadet corps

in Canada, RCSCC *John Travers Cornwell, VC*, experienced a change in command, effective Oct. 1.

Lt.-Cdr. W. Sommerville, RCSCC, on that date terminated his three-year term as commanding officer of the Winnipeg corps and turned over the captain's sword to Lt. D. B. Wilkie, RCSCC, former executive officer.

Lt.-Cdr. Sommerville had been with the corps for 17 years.

Headquarters of the corps are at HMCS *Chippawa*, the Winnipeg naval division.

Home from the Sea



CNA Appoints Honorary Padre

Rev. Canon Harry Ploughman, former Chaplain of the Fleet (P), has accepted the appointment of honorary chaplain to the Canadian Naval Association, it was announced following a meeting of the board of directors of the CNA at Hamilton in August.

Canon Ploughman was recently appointed to St. Paul's Church, Almonte, Ont., about 30 miles west of Ottawa.

The directors welcomed an application for membership in the CNA from the North Saskatchewan branch, of Saskatoon, and also the news that the Sault Ste. Marie NVA was actively assisting in the organization of a branch in North Bay, Ont.

H. A. Maynard, president of the CNA, reported on his trip to *Cornwallis* where he presented the CNA's engraved sword to the outstanding graduate of the Limited Duty Officers' Qualifying Course. The ceremony, held on July 3, saw the presentation of the sword to Cd. Off. Thomas Miller, of Dartmouth, N.S., the first recipient of the honour.

Mr. Maynard reported he was overwhelmed by the "red carpet" treatment

afforded him at *Cornwallis* by the commanding officer, Captain J. M. Paul, and the officers and men of the training establishment. He was deeply impressed by the high standard of training, the quality of accommodation and messing and the many amenities made available to the men, from non-public funds, for their comfort and leisure.

He observed that the muddy roads and dark, sombre grey buildings, so well remembered by the veterans of the Second World War, were conspicuous by their absence. He found that the *Cornwallis* of today exuded freshness and colour and "bristled with efficiency".

A progress report was submitted by Guelph, Ont., delegates in connection with the preparations for the annual reunion, to be held in their city in 1965. The dates set for the reunion are May 21 to 24 inclusive.—S.R.P.

NOAC Names Two Officers

The national president and board of directors of the Naval Officers' Associations of Canada have announced the appointment of H. McClymont, of Ottawa, as national executive secretary

and E. W. Burns, of Montreal, as treasurer, both appointments effective Sept. 27, 1964.

Both are lieutenant-commanders on the RCN and RCNR retired lists respectively.

Allied Landings Commemorated

Commemorating the 20th anniversary of the successful Allied landings on the south coast of France, the President of France, General Charles de Gaulle, officiated at the opening of a French memorial museum at Mount Faron, near Toulon, on August 15.

Canadian forces in this commando-type assault included HMCS *Prince David*, HMCS *Prince Henry* and other naval craft, and the 1st Canadian Special Service Battalion, a parachute unit, which was the Canadian component of the First Special Service Force, a joint American-Canadian formation.

Organized in 1942 as a parachute battalion, the 1st Canadian Special Service Battalion was on operations in the Kiska landings, in Italy, north of Naples, at the bridgehead at Anzio in January 1944, and in the advance on Rome in May and June. The Force made the Toulon landings at Port Cross and Levant, east of Toulon, and advanced inland covering the Allied right flank until November 28, on which date it ceased to exist.

Known as the "Memorial de Debarquement", the museum was created by altering an old fort and providing therein rooms in which the participating countries have placed on display mementoes of the landing. The Canadian room shows the Canadian Red Ensign, a bust and a photograph of Canada's war-time Prime Minister, the late Rt. Hon. W. L. M. King, medals and stars awarded in connection with the engagement, photographs of the participating RCN ships and of senior naval and army officers, shoulder flashes of the Force, uniforms and other items.—

Canadian Veterans News-Notes



Lt.-Cdr. E. A. (Ted) Fallen, departing Commanding Officer of HS-50 Squadron, leaves his ship (Squadron) by a unique method. His officers really "put their weight into it"—but moving nine-ton "05", the first all-Canadian CHSS-2, was really accomplished by a pushing aircraft tractor, not shown. Cdr. John Douglas (Darky) Lowe became commanding officer at a brief change-of-command ceremony at squadron divisions. Cdr. Lowe, no stranger to *Shearwater*, is a native of Red Deer, Alberta, and was the first RCN aviator to qualify as a helicopter pilot. (DNS-34133)

HOW WET WAS THE OCEAN

THE ENFORCEMENT of prohibition in the United States was probably the most difficult job a people ever handed to the various arms of the law.

"It is said that in one court, a Coast Guard witness was asked what he had found in a seized motorboat. 'One hundred cases', replied the witness, to which the judge said: 'I thought this was a matter of liquor. There is no law against cases. Case is dismissed'."

The quotation is from *Rum War at Sea*, the account written by Cdr. Malcolm F. Willoughby, USGR(T), of the role of the U.S. Coast Guard in enforcing the dry laws of the '20s. It was a thoroughly thankless task and one in which the USN declined to co-operate, so that, in the end, the Coast Guard had to be supplied with destroyers and thereby became an important maritime force.

Prohibition will be remembered as an experiment that spawned an impressive contempt for the law, created heroes of the sleazy, grotesque, greedy and vicious and made some unlikely Canadians and Americans very rich and socially acceptable.

The facts are (as recorded by Cdr. Willoughby's book) that only a third of the rum-running was done by sea. The rest of it was across the Detroit River, the Mexican border or from "legal" export houses in Saskatchewan or other parts of Canada near the "undefended" border. If the Americans had not been so sick of their own law, they might well have taken drastic action against Canada, which was, strange to say, also experimenting with prohibition during part of the time.

The contrary was true. Canada and Britain resorted to the courts on a number of occasions to claim damages from the United States for interfering with their rum-runners.

One lasting international complication may have arisen from the rum war—the 12-mile limit. The Coast Guard initially operated under the handicap of not being able to touch (legally) the ships of Rum Row, lying brazenly little more than three miles from shore. Some rather speedy motorboats were afloat by that stage of history and the Coast Guard was at an obvious disadvantage. (The Detroit River was the toughest problem of all, there being no question of a 12-mile, three-mile or even a one-mile limit there). The U.S. negotiated with the British and other governments the right to search vessels for liquor

BOOKS for the SAILOR

up to one hour's steaming time from shore. Taking into account the speed of vessels of the day, this averaged out to about 12 miles, which came to be regarded as the offshore limit, where prohibition was concerned.

A meticulous observer of the territorial limit was the schooner *I'm Alone*, out of Lunenburg, Nova Scotia, which busied herself along Rum Row for four years, under Captain John T. Randall. Her auxiliary engines could propel her at 12 knots and her holds had a capacity of some 2,800 cases of liquor. Despite the special attention she received from the Coast Guard, she is said to have earned \$3 million for her owners.

The 12-mile limit was involved in the incidents that brought a close to her career. When the *I'm Alone* attempted to meet her clients at a spot in the Gulf of Mexico halfway between the Mississippi delta and the Texas border, she was "watched and beset" by the Coast Guard's *Wolcott*. Only a small portion of the cargo of 1,500 cases had been sold when, on March 20, 1929, the *Wolcott* came up and ordered the *I'm Alone* to heave to. The Coast Guard claim was that the point of contact was 10.8 miles from shore, while Captain Randall, a careful observer of the 12-mile limit on other occasions, claimed he was 15 miles from land. After firing warning blanks and trailing the *I'm Alone* for several hours, the *Wolcott*, after a final warning, resorted to live shell, slightly wounding Randall. The chase continued all night and all through the next day and following night. Then another Coast Guard cutter, the *Dexter* appeared, shelled the *I'm Alone* and holed her. She sank and one member of the crew died.

There were loud cries of "piracy" over the incident. As a result of long international litigation, Canada was awarded damages of \$50,666 and an apology, Captain Randall and his crew received \$25,666 and the owners of the ship and liquor got nothing. Captain Randall gave up the sea.

But if Captain Randall had had enough of seafaring, this was not true of other Canadians in the Rum War.

Numbers of them went on active service in the Navy at the outbreak of the Second World War and, for the most part, served Canada well.

Cdr. Willoughby gives a clear and concise account of the Coast Guard's war against the rum runners—a war fought with inadequate equipment and something less than wholehearted support from the American public.

The author comments in his final paragraph:

"Coast Guard personnel almost to a man rose above the frustrations and discouragements offered by unsympathetic courts, unpopularity with the public, and the temptations of the period. Their dedication to a duty which was distasteful, their conscientiousness in carrying out their assignments, and their courage in meeting the challenge of violence, was a credit to them and in accordance with the high standards of the U.S. Coast Guard."

There can be little quarrel with Cdr. Willoughby's appraisal of the role of the Coast Guard and there can be dead certainty that his story will be read with keen interest by all naval officers and men, serving or retired, whose memories extend back to prohibition days.—H.M.C.

RUM WAR AT SEA, by Malcolm F. Willoughby, Cdr. USGR(T); for sale by the Superintendent of Documents, U.S. Government Printing Office, Washington, D.C., 20402, U.S.A.; 183 pages, illustrated, with appendix and index; \$2.

SCIENCES OF THE SEA

"The world . . . must be mad to spend more in a year on space research than has been spent on studying the oceans in the last hundred years."

The quotation, attributed to Sir Frederick Brundett, appeared in an article, "Exploration of the Sea", by H. B. Milner, in the British scientific weekly magazine, *Nature*, Nov. 23, 1963 issue.

The reason given for the expenditure of vast sums on space research is that it is essential for defence. Left unsaid is that much of the motivation for such extravagant expenditure may be the desire not to lose face before the uncommitted nations.

Now at hand is a book that makes it quite clear that a major argument for a great increase in expenditure on oceanography is the one pleaded for space research, namely, defence. The book, *Ocean Sciences*, is a survey of the subject, with a definite slant toward naval requirements. Many of the contributing authors are serving officers of the U.S. Navy and most of the others are persons who have engaged in navy-inspired research.

Many Canadian sailors are familiar with that important oceanograph device, the bathythermograph, which is capable of determining the temperature of sea water at specified depths while the ship carrying the device is motionless or under way. The inventor of this device, so useful in sonar studies, is Athelstan Spilhaus, dean of the Institute of Technology, University of Minnesota. He writes the final chapter in the book, "Oceanography's Future".

He concludes that, in a hungry world that is going to have to look to the oceans for a major portion of its protein supplies the old concept of the freedom of the seas may have to be modified.

"The freedom of the seas has been jealously preserved over the ages. But as we get more things from the sea—no longer just along our shorelines, but from the open ocean—we will need to make international agreements which

STORY OF THE BEAR

BUILT IN 1874 at Dundee, Scotland; served 10 years in the Newfoundland sealing fleet; joined the U.S. Navy and rescued the survivors of the Greely Expedition in 1884; spent 41 exciting and often dramatic years on the Alaskan patrol; became the headquarters of a maritime museum in California; made two expeditions to the Antarctic in the 1930s; served for over two years during the Second World War on the USN's Greenland Patrol; lay derelict for almost 20 years on a Nova Scotian beach; and finally foundered in a storm off Sable Island in 1963.

This is more than enough history for any ship, but it is merely the bare outline of the story of the little wooden barkentine *Bear*.

Similarly, the book *Sea of the Bear* is not the history of this remarkable vessel; it is a mere fragment of that history. It calls itself a "Journal of a voyage to Alaska and the Arctic in 1921" made by Lt.-Cdr. M. A. Ransom, USCG (Ret), but unfortunately it is not that.

will perhaps include the granting of rights for exploitation. When no one nation owns parts of the ocean, then no one nation worries about the conservation of its resources. Rights to exploitation would carry with them the responsibilities for conservation", says Dean Spilhaus.

This, as must be evident from the above quotation, is a wide-ranging book that doesn't confine itself to the military aspects of oceanography. It deals also with physical oceanography, marine biology and geology, instrumentation and underwater research vehicles, fisheries, atomic and other wastes as they affect the sea, organization of research, and so on.

Since the superstitions of the sea seem to spread much more rapidly than the facts, this might not be a bad book to be given a prominent place in any ship's library. It is well indexed, has a number of useful appendixes and a glossary, is liberally illustrated with drawings *a la* Hendrik Willem van Loon and, in common with most U.S. Naval Institute productions, is handsomely printed and bound. Private purchasers may find the price a bit on the high side.—H.M.C.

OCEAN SCIENCES, edited by Captain E. John Long, USNR (Ret); published by the United States Naval Institute, Annapolis, Maryland, U.S.A.; 306 pages; illustrated; \$10.

It is an account of this voyage, written up from a diary kept by Lt.-Cdr. Ransom and, according to the preface, "polished into a concise, readable narrative by Eloise Engle."

One wishes that this "polishing" had been left undone. Had the diary or

Sailors Coin Nicknames

Nicknames fly so fast in the RCN Atlantic Command that it's hard to keep up with them. Here are a few generally in vogue:

Clockwork Mouse: Refers to the CASEX series of graduated anti-submarine exercises.

Ponderosa: HMCS *Bonaventure*, aircraft carrier and largest ship in the RCN.

Arthur B. Ashcan: HMCS *Athabaskan*, Canada's only Tribal still in commission.

Annapolis: DDE 265 (*Annapolis*) completing in Halifax shipyards for RCN.

journal been published in its original form it would at least have been an authentic record. As it is, despite the real interest of the story being told, it is sometimes painfully artificial.

Sea of the Bear, however, is worth reading; more than that, it is worth buying: If one can ignore the style and mentally edit the dialogue, the story is a truly interesting one. And the many remarkable photographs, most of them taken with a "drugstore-type Eastman Kodak", atone for the sins of the text.—T.T.

SEA OF THE BEAR, by Lt.-Cdr. M. A. Ransom, USCG (Ret), with Eloise Katherine Engle, published by the United States Naval Institute, Annapolis, Maryland, 119 pp., illustrated. \$5.00.

TALL SHIPS

A NORTH ATLANTIC race, linked with the New York World's Fair, was sponsored this summer by the Sail Training Association. The Norwegian ship *Christian Radich* (13,000 feet of sail) won the Portugal-Bermuda ocean race and took part with 23 other stately sailing ships in a nostalgic sailpast called Operation Sail, in New York harbour in July. She later called at Great Lakes ports.

Canada was represented by the schooner *Blue Nose II*, Nova Scotia replica of the vessel on the Canadian dime., and by the Sea Cadet barquentine *St. Lawrence II*, out of Kingston.

Warren Armstrong, writer of seven sea books, penned *Square-Rigger Days*, published in June by The John Day Company, New York, and simultaneously by Longmans Canada Limited, Toronto in honour of Operation Sail. His are tales of the heyday of sailing ships, the clippers, the schooners, and of fortunes and misfortunes that befell them on the high seas and inshore. It's a stirring subject and Mr. Armstrong succeeds in tempting the reader to further books.—H.C.W.

SQUARE RIGGER DAYS, by Warren Armstrong, published in Canada by Longmans Canada Limited, 55 Barber Green Road, Don Mills, Ont., 191 pages, illustrated, \$4.95.

The days of sail came alive for visitors to New York during the week of July 12-19, which was "Operation Sail Week". The organizers of this event have announced that an *Operation Sail Souvenir Booklet*, a collection of photographs of the tall ships in brochure form, has been prepared and can be had from Benart, Inc., 235 East 45th Street, New York, N.Y., for \$2.

NEW SCIENCE

From hearing aids to moon probes, from wall clocks to computers, from Dick Tracy two-way radios to death rays, the news today is about solid state physics.

The science was born a long time ago, back in the days when high school youngsters were trying to pull in the local station with galena crystal and cat's whisker radio. Only in the last

decade, however, has it flared into a great industry.

How widespread is the interest in this plump infant can be gathered from the publishers' statement that the *GE Transistor Manual*, the seventh edition of which has just appeared, has sold a million copies. This, it is believed, makes it the all-time "best seller" among industrial publications.

Although the book launches into its more than 650 pages with a concise exposition of semiconductor theory, the contents of this book are well beyond

the grasp of this reviewer, who dates to the galena crystal era. Nevertheless, it is obvious that the *Transistor Manual*, with its information on circuits, applications, characteristics and theory is likely to be considered an essential part of the electronic technician's kit.—C.

GE TRANSISTOR MANUAL, Technical editor John H. Phelps; published by Semiconductor Products Department, Advertising & Sales Promotion, General Electric Company, Electronics Park, Syracuse, N.Y.; 651 pages, with diagrams and tables; \$2.

R.C.N. RUGBY FOOTBALL TEAM - 1932



FIRST ROW: AB. J. COOMBS. PO. C. McDONALD. COMDR. V. BRODEUR. LT. CDR. C. DONALD
 PO. B. ROBINSON. LT. K. ADAMS. LT. W. PORTEOUS.
 SECOND ROW: STO. J. JONES. AB. L. JONES. LS. P. SWETMAN. PAY. LT. CAR. F. NIXON.
 STO. T. DOBSON. LS. R. BARKER. TEL. G. BANFIELD.
 THIRD ROW: SPO. H. HUDSON. AB. F. GERVAIS. CPO (NTR) W. FINDLAY. AB. R. BODGER.
 LOG. TEL. C. WILLIAMS.
 BACK ROW: LDG. SEA. R. MASSINGHAM. LT. CDR. A. WURTELE.

Combing through some souvenirs, Lt.-Cdr. Reg Mylrea found this one of a far-off autumn—the RCN's football team of 32 years ago. Three of those in the front row attained flag rank: Rear-Admirals Brodeur, Adams and Porteous. Lt.-Cdr. Wurtele, who was an acting captain during the Second World War, leads an active life today as reeve of Esquimalt. (E-78069)

SCIENCE AND THE NAVY

Leaping Torpedo Helps Research

What could easily be mistaken from the shoreline as an attempt to launch an underwater missile in Bedford Basin is really a novel experiment currently underway by Defence Research Board scientists of the Naval Research Establishment, Dartmouth.

A torpedo—the conventional weapon of the submarine—empty except for a small instrument package and air-filled for buoyancy, is hauled down tail first to the bottom of the Basin by means of a cable secured to a concrete block anchor. In response to a signal from the attending vessel, CNAV *Bluethroat*, the torpedo body is released, rising free to the surface 250 feet above. The body has a speed in excess of 30 knots at the time of exit, and continues a considerable distance up into the air before falling back to the surface of the sea for recovery and re-use.

During the water ascent, the hydrodynamic noise characteristics exhibited by the torpedo are recorded for computer programming at NRE as part of the research and development project for towed bodies. The water exit and air flight of the body create an impressive sight but yield little information of value.

The experiment is in support of a program to extend the applications of the Canadian variable depth sonar system developed by NRE scientists during the past 10 years.

There are several methods of performing these experiments apart from the obvious method of towing by ships. Experiments can be carried out in water tunnels where the body is kept stationary and the water is made to move; bodies can be suspended from powered trolleys and towed through long specially constructed water tanks.

All these experimental techniques have their own peculiar advantages and disadvantages and the choice of any particular method depends upon the exact nature of the measurements required and the facilities available. NRE is, however, taking advantage of a natural testing facility available at its "back door" in Bedford Basin.

FLYING PERISCOPE

A FLYING TELEVISION set designed to view enemy-held terrain is now undergoing feasibility tests with the Defence Research Board. If successful, it could conceivably be applied to naval as well as army use.

Called a "periscope" by its DRB inventors at the Canadian Armament Research and Development Establishment (CARDE), Valcartier, Que., the device resembles a combination of a periscope and a helicopter.

The new surveillance device, which could be operated from a vehicle such as the military personnel carrier or from shipboard, is controlled from the ground by a coaxial cable containing power and other electrical lines. A 4½-ft. helicopter-type rotor, powered by an electric motor, is used to lift the television camera into the air. The airborne elements weight 50 pounds and the system complete is about 500 pounds.

Designed to provide forward troops of battalion and smaller units with a clear view of the ground ahead for relatively long ranges, the periscope should also help to improve the performance of supporting weapon systems. By providing clear coverages of most types of terrain, corrections to firing orders could be given when needed.

Through its closed-circuit television system, the periscope is designed to give a 360-degree instantaneous look at the enemy's movements and equipment.

Initial employment of the system will be under daylight conditions, although CARDE's scientists are hopeful that improvements in the system will allow it to "see" at night as well.

The periscope is ruggedly constructed and its simplicity will require only a single operator who will require no special skills. Its small size would make it a difficult target for the enemy if it were detected.

In addition to its ability to monitor enemy action and to assist supporting



Project engineer, Christopher Wilson, of the Canadian Armament Research and Development Establishments, Valcartier, Que., demonstrates the lightness of the airborne components of the periscope, a DRB-designed surveillance device. A winch on the control vehicle stores the tethering cable and permits raising and lowering of the airborne components. (DRB Photo)

ground fire to select targets the periscope may also be useful in controlling anti-tank missiles to their targets. Its potential also embraces early warning of slow speed, low-flying aircraft.

A "Bread Board" model of the periscope was tested by CARDE this spring to ensure scientific feasibility of the project during the pre-development phases. Another model as now under construction for further and more exacting trials.

Alouette Still Sending Data

At 2:05 on the morning of Sept. 29, the Defence Research Board's Alouette topside sounder satellite, Canada's

first spacecraft, attained its second birthday and completed 9,973 orbits about the earth during a total of 288,000,000 miles travelled. The satellite is continuing to pour out scientific data about the ionosphere to earth stations.

According to A. G. Stepley, Alouette's controller at the Defence Research Telecommunications Establishment (DRTE) near Ottawa, "There has been no requirement to command into operation any of the spare equipment including the extra batteries placed within the satellite." He notes also that Alouette has executed 26,129 commands and that it has provided the scientists with data, some of it previously unknown, during a total of 3,889 hours of telemetry transmissions.

Scientists from the U.S. and Britain, as well as those from the Ottawa DRB station where the space craft was designed and fabricated, are busy analysing the information received from 5,405 miles of magnetic tape recordings.

As data analysis continues, DRTE Satellite Section members are busy testing the spacecraft's successor—to be called Alouette II and scheduled for launching from Vandenberg Air Force Base in California next summer. Although Alouette II will resemble its predecessor in size and configuration, its components have been completely redesigned and one of its antennas will be 240 feet tip-to-tip, almost twice the length of Alouette's longer antenna now "Sounding" the ionosphere.

The same space specialists are concurrently working on the design of ISIS A, a third satellite scheduled for launching in 1967, to be followed before the end of this decade with two further ionospheric satellites designated ISIS B and C.

The overall ionospheric program, carried out jointly with the U.S. National Aeronautics and Space Administration, aims to probe the ionosphere during the period of gradually increasing sunspot activity until its maximum about 1970.

Glass Studied for Submarine Hulls

A most unlikely material for the purpose (the layman will probably think), glass is being given serious consideration as the main structural material for deep-diving submarines.

The practicality of such use receives a lot of support in a research report issued by the U.S. Naval Ordnance Laboratory, White Oak, Maryland, outlined in a recent issue of *The Journal of the Armed Forces*, Washington, and also noted by other service publications.

The laboratory says glass looks attractive for deepsea structural use because:

- New chemical surface treatments greatly increase the bending and impact strength of glass.

- Plastic overlays give glass increased resistance to damage.
- A buoyant hull, having glass as the main load-bearing material, would have great resistance to mechanical damage when submerged at great depth.
- Because glass is transparent, structural defects could be determined readily by optical means.
- A glass submarine would provide a "picture window" from which to view the deep by means of artificial light.

A great many different qualities can be built into glass. It can be made resistant to sharp temperature changes; it can be made either stiff or flexible, an insulator of electricity or a conductor; transparent or opaque or selectively opaque to just certain wave bands of light.

Glass is usually thought of as a hard, brittle, transparent substance. Because it has no definite melting point, passing from brittleness to liquidity in imperceptible stages, it is sometimes considered a liquid—although a highly viscous one. Its chemical formulae are so varied that it cannot be defined chemically and some scientists prefer to think of glass as another state of matter than a distinct substance.

The qualities of glass as they are affected by heavy pressure in the depth of the sea were thoroughly investigated by the Naval Ordnance Laboratory early this year.

From the Corning Glass Works and the Pittsburgh Plate Glass Company, it obtained 95 hollow glass spheres. Each sphere was lowered to a specified depth in the Puerto Rico Trench from the USN research vessel *Gillis*. One-pound explosive charges were mounted at specified distance from each sphere.

At depths of 300, 7,000, 14,000 and 21,000 feet the charges were detonated by hydrostats. If no damage was done to a sphere, a charge was placed closer to it to determine how much shock it could stand. Several spheres were used at each depth, with explosives at varying distances.

The tests made the discovery that the deeper the spheres went, the greater their resistance to shock, so that at 21,000 feet the glass spheres were five times as strong as near the surface. Metals show less resistance to damage the deeper they go.

The Naval Ordnance Laboratory team carried out another series of tests in June, using more complicated spheres (with hatches and electrical lead-ins) and glass containers of varied shapes, cylindrical and toroid (doughnut), for

example. Again, resistance to shock waves increased with depth.

They also tested plastic-coated objects and found that a plain glass sphere, covered by plastic only 1/8 inch thick, had its resistance to damage doubled.

Now the research group is carrying out tests on two-inch-thick, surface-compressed spherical hull segments, but, *The Journal of the Armed Forces* points out, much engineering and evaluation remain to be done before conclusions can be drawn.

The past summer saw the launching of a new submarine designed for deep diving. This is the *Aluminaut*, built for the Reynolds Metals Company by the Electric Boat Division of General Dynamics, Groton, Conn.

The *Aluminaut* is constructed almost entirely of aluminum, has a range of 80 miles, a cruising speed of 3.8 knots and an operational depth of 15,000 feet. The little submarine can carry a pilot and two scientists on cruises of up to 72 hours.

Although the venture is a private one, the *Aluminaut* is being watched with interest by the U.S. Bureau of Naval Weapons. She has both vertical and horizontal propulsion motors and external handling gear. Her possibilities in ocean-bottom salvage, oil drilling and mining operations will be investigated.

RN Updating Survey Fleet

The ordering of three ocean survey ships and the intention to build an ice-breaker are an important part of a program which will modernize the Royal Navy's Survey Fleet. The Admiralty Board has now named these ships.

The modernization program also includes six ships of a new class of coastal survey craft, the conversion into hydrographic craft of two coastal minesweepers and the replacement of two old survey motor launches by two inshore minesweepers. These 10 additional ships have also been named, or renamed. The whole program will eventually give a completely new look to the Survey Fleet.

In his annual report, the Hydrographer of the Navy stated that his present fleet was "stretched to the limit" by a progressive expansion of effort which he attributed to three main reasons: First, that supertankers need more extensive knowledge of underwater topography; second, that the quest for untapped fuel resources beneath the sea has stimulated interest in the continental shelves, and third, the requirements of deep diving nuclear-powered submarines.

THE NAVY PLAYS

Stadacona Wins Football Opener

Stadacona Sailors for the fifth consecutive year won the traditional service opener of the Atlantic Football Conference Sept. 19 over the *Shearwater* Flyers, this time 21-13. A near capacity crowd of 3,000 was at Bidwell field for the opener.

Stad got TDs on their first two series of play from scrimmage and dominated play until the third quarter when *Shearwater* edged to within one point.

Stad clinched the game with five minutes to go on a pass play that yielded a converted touchdown.

Scientist Tops Handgun Meet

The RCN Atlantic Command Handgun Club for the second year running was out in force this summer at the Connaught ranges near Ottawa for the National Handgun Matches and Canadian Service Pistol Championships.

Gary McMahon, NRE scientist, who earlier won his second berth at Brampton, Ont., in Canada's Olympic pistol



The commanding officer of Cornwallis, Captain J. M. Paul, presents the New Entry Competition trophy for the tug-of-war to Fraser division, represented by Ord. Sea. Marshall Worobets. (DB-19377)

team, tied at Connaught with P. Abram, of Midland, Ont., with an aggregate of 1,723 of a possible 1,800 points but, with 73 X-ring shots to Abram's 55, was top man of the meet.

A total of 115 handgunners competed for 17 awards at the matches, which preceded the annual DCRA shoot.

Ottawa Cadets Win Regatta

A sailing crew from RCSCC *Falkland*, Ottawa, won the third annual National Sea Cadet Regatta at Hamilton, Ont., in August, scoring 51 3/64 points. The crew was skippered by Ldg. Cadet Don Fraser.

Ldg. Cadet Fraser's crew won three straight races to capture the title. Five races had been scheduled for the 17 crews, but bad weather on the first day of the two-day regatta curtailed the program.

Second place in the regatta was won by RCSCC *Revenge*, Penticton, B.C., with Ldg. Cadet H. Bomford as skipper. The *Revenge* crew took 48 points, four ahead of the third place winner, the crew entered by RCSCC *Rainbow*, of Vancouver.

All provinces were represented among the 17 sea cadet crews, with the exception of Nova Scotia and Prince Edward Island.

Navy Launches Curling Season

The Navy led the way as sailors took to the ice in the last week of September to get the 1964-65 curling season underway in Ottawa, with a mixed bonspiel.

They made it official Oct. 9 with a brief ceremony attended by guests from other clubs in the capital. Ottawa has a total of 14 curling clubs. Commodore S. E. (Stu) Paddon is president of the RCN Curling Club of Ottawa.



GARY McMAHON

HERE AND THERE IN THE RCN



Miss M. C. (Jeannine) Belanger, chief supervisor of the naval communication centre at Canadian Forces Headquarters in Ottawa, received her 25-year Civil Service pin Sept. 29 from Rear-Admiral M. G. Stirling, Chief of Naval Personnel, who, as a naval communications specialist, first met her in May 1942. The presentation witnesses included Commodores J. A. Charles and R. W. Murdoch, also former communicators. Miss Belanger, who lives in Hull, Que., began work in 1939 as a coder in the NAVCOMCEN, and has performed highly specialized work there ever since.



The Naval Fire Service in the Pacific command joined municipal fire departments in the Greater Victoria area in promoting Fire Prevention Week, October 4 to 10. A highlight of the activities was a parade of Victoria area firefighting equipment through downtown Victoria, led by the Naden band. Playing a major role in the week's activities was 17-year-old Gail Hanson, a dockyard civilian employee who doubles as Miss Dockyard and as Miss Firefighter. Left to right are Deputy Pacific Command Fire Chief Gordon Morrison; Saanich Fire Chief Joseph Sunderland; Pacific Command Fire Chief Lt.-Cdr. Gordon Ball; Gail Hanson; Victoria City Fire Chief John Abbott; Al Reside, representing Oak Bay firemen, and Lt. Fred Briggs, of the Oak Bay department. (E-78322)

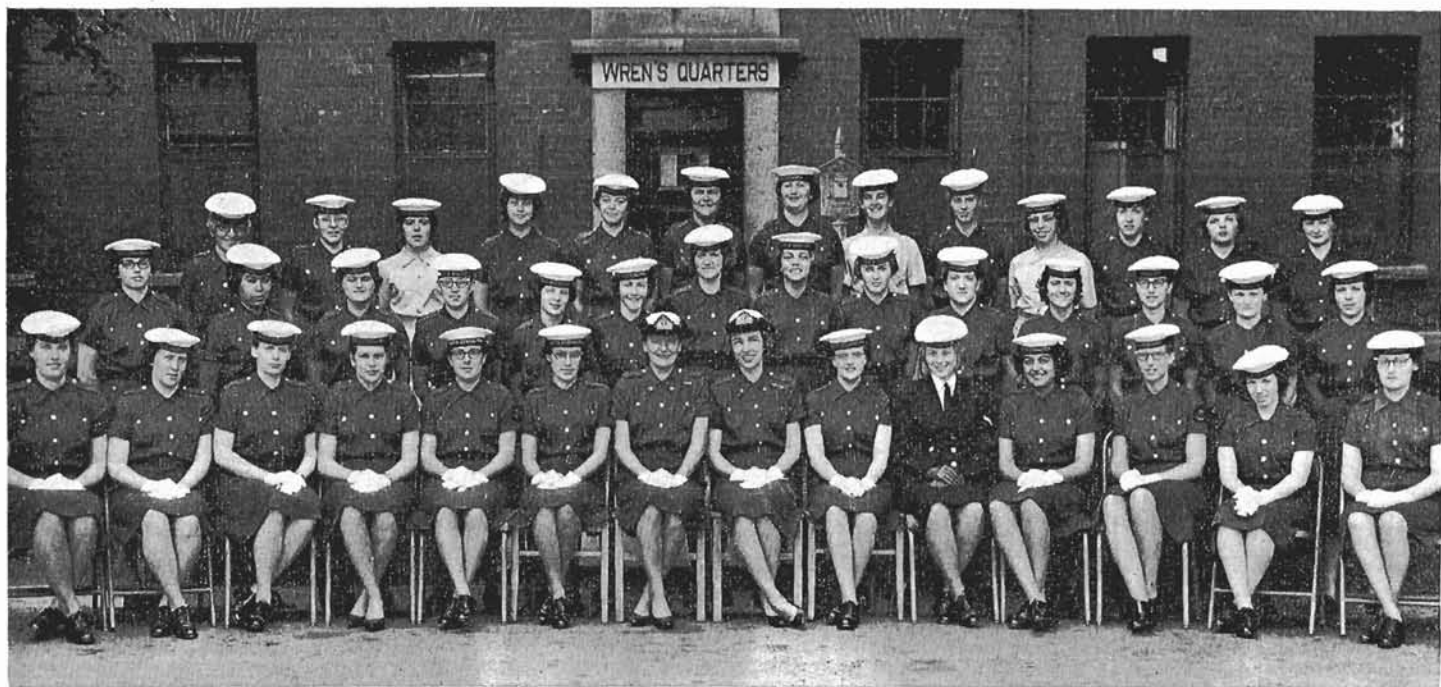

The Stadacona wrens met in the wren's quarters on July 29 to wish Lt. A. L. Doupe, of Saint John and Halifax, bon voyage on her exchange appointment to HMS Vernon in Portsmouth, England. Lt. Doupe had been Commander's Assistant and Senior Wren Divisional Officer in HMCS Stadacona for the past two years. Sub-Lt. L. Arnold has assumed these appointments. (HS-75721)

RETIREMENTS

CPO WILLIAM EDWARD ACKERMAN, CD and 1st Clasp; C2CM4; served in RCNVR Oct. 24, 1940, to Nov. 14, 1945; joined RCN May 11, 1946; served in Edmonton naval division, *Naden, Cougar, Prince Robert, Givenchy, Stadacona, Port Arthur, Winnipeg, Peregrine, Unicorn, Discovery, Malahat, Ontario, Antigonish, Donnacona, Hochelaga, Athabaskan, Saguenay, Royal Roads, Assiniboine, Venture*; retired Sept. 8, 1964.

CPO DOUGLAS WILLIAM ADDISON, CD and 1st Clasp; C1ST4; joined January 25, 1940; served in *Naden, Prince Robert, RCN College, Stadacona, Huron, Scotian, Micmac, Givenchy, Royal Roads, Discovery, Ontario, Cornwallis, Quebec, Donnacona, Hochelaga, St. Croix, Montcalm, Provider*; retired Sept. 20, 1964.

PO ROBERT ASHTON, P1ER4; joined RCNVR Sept. 14, 1939; transferred to RCN Oct. 17, 1945; served in *Naden, Nitinat, Haro, Princess Elizabeth, Givenchy, Stadacona, Ungava, Peregrine, Scotian, Cornwallis, Wallaceburg, Middlesex, Ontario, Beacon Hill, Rockcliffe, Cayuga, New Waterford, Sioux, Athabaskan, Antigonish, Malahat*; retired Sept. 12, 1964.

CPO PAUL AUGUSTUS BISHOP, CD; C1WR4; joined RCNVR Sept. 13, 1939; transferred to RCN Jan. 15, 1940; served in *Naden, Chatham, Givenchy, Stadacona, Niobe, Loch Achanalt, J1607, Peregrine, Crescent, Venture, Hochelaga, Stettler, Sussexvale*; retired Sept. 11, 1964.

CPO WILLIAM CHARLES BLATHWAYT, CD and 1st Clasp; C1WR4; joined RCNVR Sept. 18, 1939; transferred to RCN May 9, 1946; served in *Stadacona, Bytown, York, Malahat, Peregrine, Niobe, HMS Fledgling, Prevost, Micmac, Magnificent, Warrior, Shearwater, Naden, Hochelaga, York*; retired Sept. 17, 1964.

PO JAMES CHARLES CHAMBERS, CD; P1ER4; served in RCNR Feb. 10, 1941-Oct. 1, 1945; joined RCN(R) Oct. 6, 1947; transferred to RCN Sept. 22, 1949; served in Kingston naval division, *Stadacona, Prince David, Naden, Dawson, Chignecto, Chatham, Givenchy, Red Deer, Avalon, Scotian, Peregrine, Cornwallis, Sussexvale, Catarauqui, Nootka, Ontario, Huron, Antigonish, Victoriaville, Thunder, Haida, York*; retired Sept. 22, 1964.

CPO CHARLES HENRY CONWAY, CD; C1ER4; joined RCNR Sept. 11, 1939; transferred to RCN Oct. 19, 1940; served in *Naden, Malaspina, Prince Robert, Agassiz, Courtenay, Dawson, Givenchy, Peregrine, Niobe, Ontario, Stadacona, Rockcliffe, Cayuga, New Glasgow, Saguenay, Cape Breton*; retired Sept. 9, 1964.

CPO JAMES BERNARD DOYLE, CD; C2WS4; joined April 13, 1942; served in *Niobe, HMS Excellent, Kenogami, Stadacona, Cornwallis, St. Laurent, Swansea, Peregrine, Micmac, Donnacona, Givenchy, Naden, Nonsuch, Ontario, Crescent, Magnificent, Restigouche, Bonaventure*; retired Sept. 9, 1964.

CPO JOHN BRIGGS ELDER, CD; C2BN3; served in RCNVR June 15, 1938, to Nov. 7, 1945; joined RCN May 9, 1946; served in Saskatoon naval division, *Naden, Sans Peur,*

Stadacona, Margaree, Cornwallis, Uganda, Discovery, Givenchy, Rockcliffe, Athabaskan, Cayuga, Niobe, HMS Excellent, Sioux, Griffon, Ontario, Saguenay, Venture; awarded Long Service and Good Conduct Medal; retired Sept. 9, 1964.

CPO JOHN FREDERICK HANDLEY, CD; C2ER4; joined RCNVR Aug. 7, 1939; transferred to RCN Sept. 19, 1940; served in Halifax naval division, *Stadacona, Vierno, Ypres, St. Frances, Rimouski, Nipigon, Ville de Québec, Scotian, Port Colborne, Westmount, Peregrine, Huron, U-190, Iroquois, St. Stephen, Nootka, La Hullose, Haida, Wallaceburg, Swansea, Huron, Quebec, Lauzon, Saguenay, Athabaskan, Niobe, Provider*; retired Sept. 5, 1964.

CPO ROY EDWARD HANSON, CD; C2HT3; joined RCNVR Sept. 3, 1943; transferred to RCN Oct. 17, 1945; served in *Stadacona, Scotian, Shelburne, Iroquois, Magnificent, Bonaventure, Cape Scott*; retired Sept. 1, 1964.

PO HUBERT JOHN McCAW, P2RM3; served in RCNVR April 2, 1937, to Nov. 7, 1945; joined RCN(R) July 16, 1946; transferred to RCN June 23, 1954; served in *Naden, Stadacona, Vierno, Chaleur, Levis, Avalon, Napanee, Bytown, St. Hyacinthe, Chippawa, Aldergrove, Antigonish, Portage, Athabaskan, Wallaceburg, Cornwallis, Jonquiere, New Glasgow, Cape Breton*; retired Sept. 12, 1964.

CPO HAROLD NEALE McINTYRE, CD; C1ER4; joined RCNVR July 29, 1940; transferred to RCN Sept. 9, 1943; served in *Naden, Quesnel, Bellechasse, Stadacona, Columbia, York, Givenchy, Niobe, Arnprior, Avalon, Protector, Cornwallis, Peregrine, Wentworth, Ste. Therese, New Waterford, Rockcliffe, Ontario, Cedarwood, Bytown, Oshawa, Victory, Bonaventure*; retired Sept. 13, 1964.

CPO ARTHUR IRVIN MYATT, CD; C1CM4; joined RCNVR Sept. 22, 1939; transferred to RCN Sept. 1, 1941; served in *Stadacona, Festubert, Restigouche, Avalon, Protector II, Shelburne, York, Cornwallis, Nootka, Iroquois, Swansea, Cape Breton, Quebec, Haida, Naden, Bonaventure, Hochelaga, Cape Scott*; retired Sept. 21, 1964.

PO SYDNEY JAMES NETTLETON, CD; P1ER4; joined RCNVR Sept. 22, 1943; transferred to RCN June 5, 1944; served in *Star, York, Cornwallis, Stadacona, Avalon, Glace Bay, Niobe, Warrior, Iroquois, Donnacona, St. Stephen, Wallaceburg, Quebec, Cape Breton, Bonaventure, Ottawa, Terra Nova, Micmac*; retired Sept. 29, 1964.

CPO FLOYD WORTHINGTON NOYES, CD and 1st Clasp; C1WR4; served in RCNVR Feb. 10, 1937 to Oct. 31, 1937, and from Nov. 16, 1938, to March 19, 1941; transferred to RCN March 20, 1941; served in Saskatoon naval division, *Naden, Armentieres, Comox, Skidegate, Givenchy, Avalon, Hunter, Stadacona, Haligonian, Niobe, Warrior, Rockcliffe, Cornwallis, Ontario, Bytown, Donnacona, Sioux, Margaree, Queen, Chippawa*; retired Sept. 19, 1964.

CPO JOHN EDWARD PLASTOW, CD; C2MA4; served in RCNVR July 6, 1942 to Jan. 21, 1946; joined RCN March 21, 1946;

served in *Nonsuch, Stadacona, St. Laurent, Peregrine, Naden, Royal Roads, Sioux, Cornwallis, Athabaskan, Aldergrove, Skeena, Discovery*; retired Sept. 1, 1964.

PO ALFRED EDWARD RALSTON, CD; PICK3; joined RCNVR June 7, 1939; transferred to RCN Oct. 18, 1945; served in Toronto naval division, *Stadacona, SS Pasteur, St. Laurent, Avalon, Snowberry, Arvida, Amherst, Sudbury, Naden, Givenchy, Wolf, York, Ontario, Warrior, Niobe, Magnificent, CANAS Dartmouth, Coverdale, Cornwallis, Outremont, Cape Scott, Bonaventure*; retired Sept. 20, 1964.

CPO EDWARD JOHN SOADY, C1ER4; joined RCN Jan. 3, 1946, after service in Royal Navy; served in *Niobe, Warrior, Naden, Rockcliffe, Ontario, Royal Roads, Cedarwood, Griffon, Ste. Therese, Skeena*; awarded Long Service & Good Conduct Medal; retired Sept. 2, 1964.

OFFICERS RETIRE

LT.-CDR. FRANK ERNEST BARLOW, CD; commenced service in the RCNVR on Feb. 4, 1926, as an able seaman; transferred to RCN on May 14, 1928; promoted to acting gunner Feb. 14, 1941; served in *Stadacona, Festubert, Champlain, HMS Victory, HMS Warspite, HMS Vernon, HMS Champion, HMS Victory, Saguenay, HMS Iron Duke, HMS Nelson, Gaspé, Laurier, Sydney, HMS Dryad, Niobe, Skeena, Iroquois, Uganda, Stadacona, Magnificent, Bytown, Naden, Crescent*; last appointment, HMCS *Stadacona* on staff of Commodore Superintendent Atlantic Coast for Ship Repair; commenced leave, Sept. 9, 1964; retires Jan. 6, 1965.

LT. DESMOND SANSFIELD BENDER, CD; commenced service in the RCN(R) on Aug. 24, 1950, as a lieutenant (SB); transferred to RCN as lieutenant (SB), Aug. 24, 1951; served in *Carleton, Bytown, Cornwallis, Montcalm, D'Bererville*; last appointment, Naval Headquarters, on staff of Assistant Director Naval Manning (Recruiting); commenced leave, Sept. 28, 1964; retires on Feb. 8, 1965.

LT.-CDR. ERIC GERALD TICE FISHER, CD; commenced service in the RCNR on Nov. 12, 1942, as a sub-lieutenant; served in *Niobe, Cornwallis, Dundas, Pictou, Lethbridge, Battleford, Stadacona, Sea Cliff, Provider, Scotian*; demobilized Sept. 16, 1947; joined RCN(R) Nov. 1, 1949, as lieutenant; transferred to RCN June 18, 1951; served in *Scotian, Middlesex, Iroquois, Naden, Naval Headquarters*; last appointment, *Bytown*, on staff of Director of Naval Ship requirements; commenced leave Sept. 18, 1964; retires on Feb. 14, 1965.

COMMODORE ALEXANDER BEAUFORT FRASER-HARRIS, DSC & BAR, CD; served in Fleet Air Arm during Second World War; joined the RCN(R) on Nov. 13, 1946, as lieutenant-commander (P); transferred to RCN as lieutenant-commander (P), Dec. 19,

1946; served in *Donnacona*, *Bytown*, *Stadacona*, *Shearwater*, *Haida*, *Nootka*, *Niagara*, *Magnificent*, *Niobe*; last appointment, Naval Headquarters as Assistant Chief Naval Staff (Air and Warfare); commenced leave Aug. 22, 1964; retires on April 29, 1965.

CDR. G. C. E. GRAY, CD; commenced service Jan. 1, 1942, in the RCNVR as a sub-lieutenant (SB); served in *Hunter*, Naval Headquarters, *Stadacona*, *Cornwallis*; transferred to RCN June 6, 1946, as instructor lieutenant; served in *Naden*, *Uganda*, *Ontario*, *Cornwallis*, *Stadacona*, *Niobe*, *Stettler*, *Sussexvale*, *Venture*; last appointment *Venture* as Director of Studies; commenced leave Sept. 20, 1964; retires on April 8, 1965.

A/CAPTAIN VINCENT LAWS, CD; commenced service in the RCN Sept. 1, 1933, as a paymaster cadet; served in *Stadacona*, *HMS Frobisher*, *HMS London*, *HMS Durban*, *HMS Devonshire*, *HMS Woolwich*, *HMS Resource*, *HMS President IV*, *HMS St. Angelo II*, *HMS Victory*, *HMS Ramillies*, *HMS Newcastle*, *Naden*, *Restigouche*, *Venture*, *St. Hyacinthe*, Naval Headquarters, *Givenchy*, *Niobe*, *Warrior*, *Scotian*, *Stadacona*, *Magnificent*; last appointment, *Naden* on staff of Flag Officer Pacific Coast as Command Supply Officer, with acting rank of captain; commenced leave Sept. 15, 1946; retires on May 19, 1965, with acting rank of captain.

LT.-CDR NORMAN THOMAS LONG, CD; commenced service in the RCN(R) on Sept. 28, 1949, as a lieutenant; transferred to RCN Sept. 1, 1952, as lieutenant; served in *York*,

Bytown, *Stadacona*, *Shearwater*, *Naden*; last appointment, Naval Headquarters on staff of Director Naval Works; retires on Sept. 1, 1964.

LT. WILLIAM WHITE MARCUS, CD; commenced service in the RCNVR on April 16, 1942, as a probationary supply assistant; demobilized in the RCNVR Dec. 19, 1945; served in *Chippawa*, *York*, *Naden*, *Stadacona*, *Nipigon*, *Oakville*, *Fundy*, *Brantford*, *Peregrine*; entered RCN(R) as stores assistant Oct. 28, 1947; transferred to RCN as Acting Commissioned Stores Officer March 4, 1948; served in *Chippawa*, *Portage*, *Athabaskan*, *Naden*, *Ontario*, *Royal Roads*, *Cornwallis*, *Cape Scott*, *Stadacona*; last appointment, *HMCS Stadacona* on staff of Base Superintendent Sydney as Manager Supply Department; retired on Aug. 26, 1964.

CHAPLAIN (P) BRUCE ADOLPHE PEG-LAR, CD; served in Canadian Army Nov. 13, 1943 to April 15, 1946, as a captain; commenced service June 3, 1946, in the RCN; served in *York*, *Scotian*, *Warrior*, *Stadacona*, *Royal Roads*, *Naden*, *Sioux*, *Quebec*, *Magnificent*, *Cape Scott*; last appointment, *Stadacona* as Command Chaplain (P) Eastern Command; commenced leave Sept. 19, 1964; retires on March 7, 1965.

LT.-CDR. FREDERICK CLEMENT PETTIT, CD; commenced service in the RCN on July 31, 1939, as an ordinary seaman; promoted to acting sub-lieutenant on Jan. 1, 1944; served in *HMS Excellent*, *Stadacona*, *Niobe*,

HMS Arethusa, *HMS Osprey*, *Naden*, *Antigonish*, *Cornwallis*, *Magnificent*, *Malahat*, *Venture*, *Hochelaga*; last appointment, *Hochelaga* as executive officer; commenced leave Sept. 17, 1964; retires on March 31, 1965.

LT.-CDR. R. L. M. PICARD, CD; commenced service in the RCNVR on Oct. 17, 1942, as a probationary sub-lieutenant (SB); served in Montreal naval division, *Cornwallis*, Naval Headquarters, *Naden*, *Stadacona*, *Donnacona*; demobilized June 8, 1946; commenced service in RCN(R) June 8, 1946; transferred to RCN May 4, 1951, as instructor lieutenant-commander; served in *Donnacona*, *Stadacona*, Naval Headquarters, *Montcalm*, *D'Iberville*, *Magnificent*, *Collège Militaire Royal de St. Jean*, *Hochelaga*; last appointment, *Donnacona* on staff of Area Recruiting Officer as naval career counsellor; commenced leave Sept. 12, 1964; retires on Jan. 7, 1965.

LT.-CDR. KEITH CLARK STOKES, CD; commenced service in the RCNVR on Jan. 15, 1941, as a writer; promoted to probationary paymaster sub-lieutenant, Dec. 22, 1941; served in *Protector*, *Avalon*, *Stadacona*, *Kings*, *Bytown*, *La Salle*; demobilized on Nov. 2, 1946; entered RCN(R) as lieutenant (S) June 29, 1948; transferred to RCN Sept. 23, 1948; served in *Bytown*, *Naden*, *Iroquois*, *Stadacona*, *Hochelaga*; last appointment, *HMCS Bytown* as supply officer and executive officer; commenced leave Sept. 11, 1964; retires on Feb. 14, 1965.



The Canada geese and the ducks on the pond are larger than the Tracker aircraft on the flight deck of the carrier, but that's the way things should be in Story Book Gardens at Springbank Park near London, Ont. It's a reposeful spot for the big model of *HMCS Bonaventure* that has done duty in other years at the Canadian National Exhibition, on the Mall in Canada's capital city, Ottawa, and elsewhere. Many years of duty and souvenir-hunting spectators had taken their toll, but the model was given a thorough face-lifting by the ship's company of Prevost, the London naval division, and found a resting place in the sylvan beauty of Story Book Gardens. (WO-64-155-1)

Naval Lore Corner

Number 131

UNDER 'SEVERAL' FLAGS

SERVICE UNDER MORE THAN ONE FLAG IS NOT UNCOMMON FOR WARSHIPS, AS WELL AS FOR MERCHANT SHIPS. SOME OF THE CIRCUMSTANCES ARE SOMEWHAT BIZARRE...

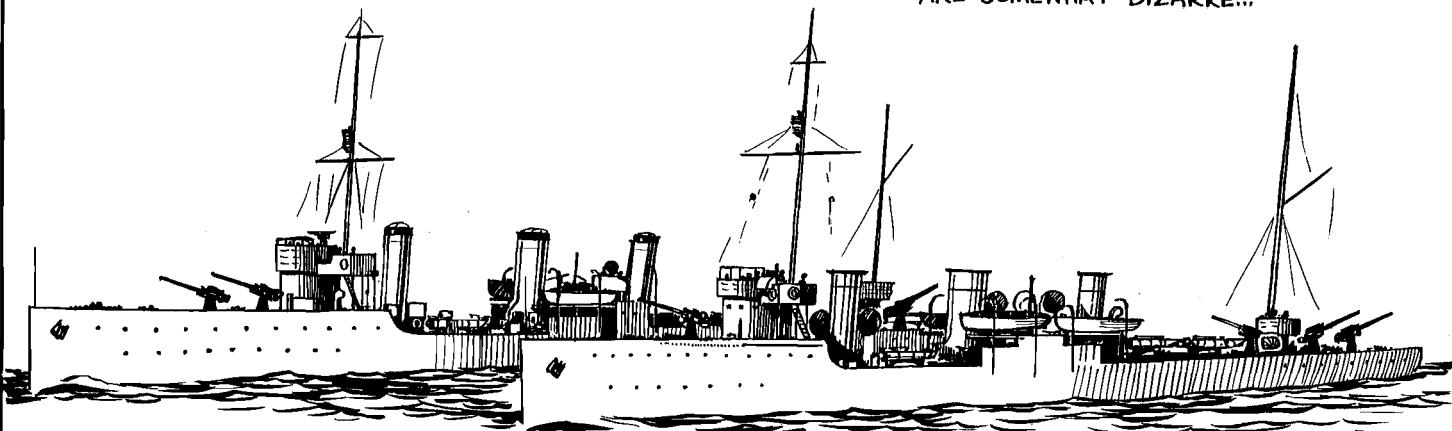

IN 1919 (DURING THE UNDECLARED WAR BETWEEN THE ALLIES AND THE RUSSIAN COMMUNISTS) THE RUSSIAN DESTROYERS "AVTROIL" AND "MIKLUHA MAKLAI" MADE A SUDDEN RAID ON REVAL AND CARRIED OUT A BRIEF BOMBARDMENT. THEY WERE PURSUED BY BRITISH LIGHT FORCES OF ADMIRAL COWAN'S FLEET, CAPTURED AND TOWED BACK TO REVAL WHERE THEY WERE PRESENTED TO THE ESTONIAN GOVERNMENT AS THE FIRST UNITS OF THEIR NEW NAVY AND RENAMED "LENNUK" AND "VAMBOLA" (ABOVE).

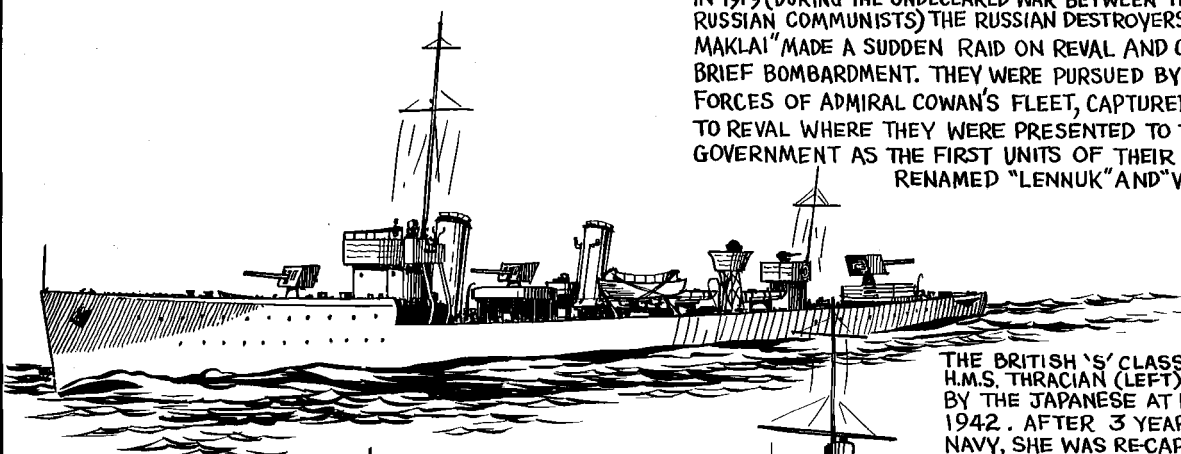

THE BRITISH 'S' CLASS DESTROYER H.M.S. THRACIAN (LEFT) WAS CAPTURED BY THE JAPANESE AT HONG KONG IN 1942. AFTER 3 YEARS IN THE JAPANESE NAVY, SHE WAS RE-CAPTURED AT TOKYO IN 1945...

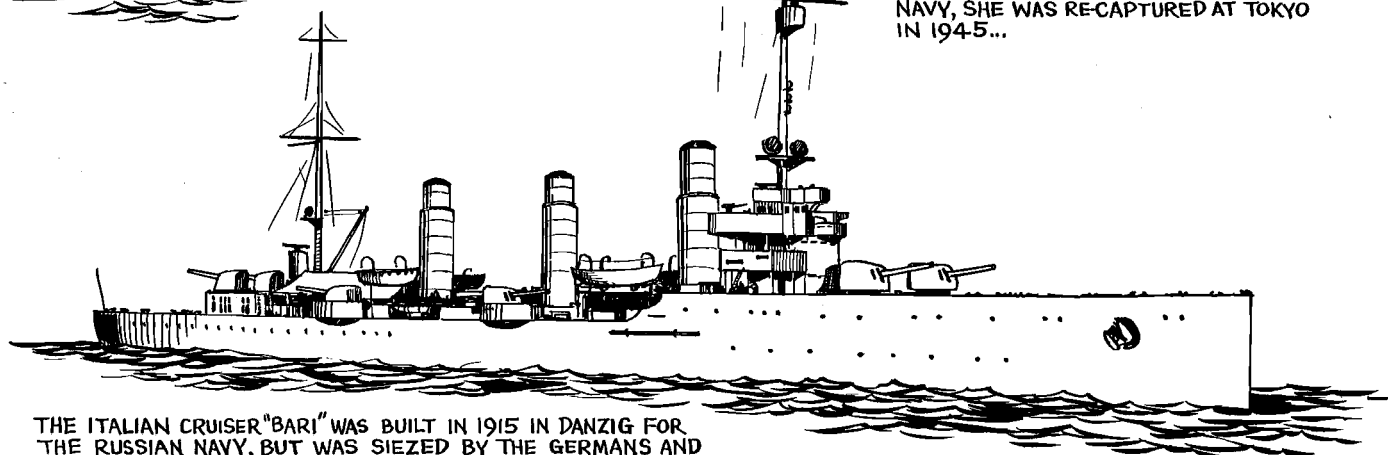

THE ITALIAN CRUISER "BARI" WAS BUILT IN 1915 IN DANZIG FOR THE RUSSIAN NAVY, BUT WAS SIEZED BY THE GERMANS AND RENAMED "PILLAU". DAMAGED AT JUTLAND, SHE SURVIVED THE WAR AND WAS CEDED TO ITALY IN 1920. SEVENTEEN YEARS LATER (28 JUNE, 1943) SHE WAS SUNK BY ALLIED AIRCRAFT IN LEGHORN HARBOUR...

CANADA
POSTAGE PAID
PORT PAYÉ

*If undelivered,
return COVER WITH CONTENTS to:*

The Queen's Printer, Ottawa, Canada

*En cas de non-livraison,
retourner cette PUBLICATION INTACTE à:*

L'Imprimeur de la Reine, Ottawa, Canada





The CROWSNEST

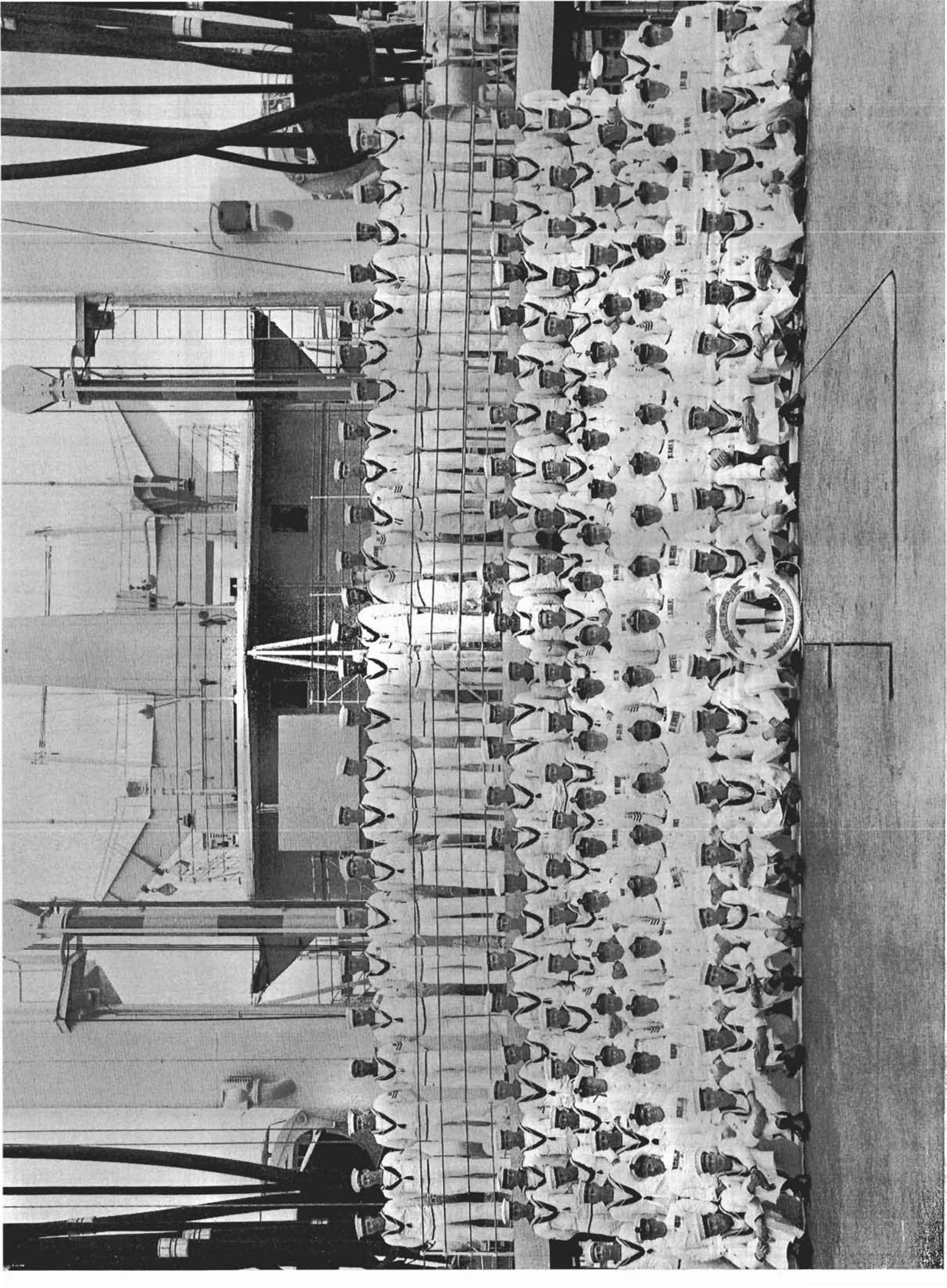

The CROWSNEST

Vol. 16 No. 12

THE ROYAL CANADIAN NAVY'S MAGAZINE

DECEMBER 1964

CONTENTS

	Page
<i>RCN News Review</i>	2
<i>Rescue Operations</i>	4
<i>Exercise Yeoman</i>	5
<i>Canlex '64</i>	8
<i>Officers and Men</i>	9
<i>The RCN 10 Years Ago</i>	11
<i>How Not to Buy a Clock</i>	12
<i>New Surgeon-General</i>	13
<i>VU-33</i>	14
<i>Housemaid of the Fleet</i>	15
<i>Home from the Sea</i>	17
<i>Science and the Navy</i>	21
<i>Books for the Sailor</i>	24
<i>Retirements</i>	27
<i>Naval Lore Corner No. 133</i>	<i>Inside Back Cover</i>

FAMILY PORTRAIT

A souvenir of the first year in commission of HMCS *Provider* is this picture of her original ship's company, taken in Las Palmas, Gran Canaria, last summer.

It was a busy year and, in many ways, a difficult one as new and unfamiliar equipment was tried out and, in some cases, rejected and replaced. She voyaged to Britain with HMCS *Yukon* in company to carry out fuelling trials, which were successfully accomplished at high speed.

Many of the officers and men shown on the opposite page have gone on course or to other ships or appointments and this includes the *Provider's* first commanding officer, Captain T. C. Pullen, who has been appointed to Canadian Forces Headquarters and succeeded by Captain Kai Boggild. (508-260)

Negative numbers of RCN photographs reproduced in *The Crowsnest* are included with the caption for the benefit of persons wishing to obtain prints of the photos.

This they may do by sending an order to the Secretary Defence Staff, Canadian Forces Headquarters, Ottawa, quoting the negative number of the photograph, giving the size and finish required, and enclosing a money order for the full amount, payable to the Receiver General of Canada.

Sizes, finish and the National Defence standardized prices, follow:

4 x 5 (or smaller) glossy finish only ..	\$.10
6½ x 8½ glossy finish only40
8 x 10 glossy or matte finish50
11 x 14 matte finish only	1.00
16 x 20 " " "	3.00
20 x 24 " " "	4.00
30 x 40 " " "	8.00

SUBSCRIPTION RATE

The Crowsnest may be subscribed for at the rate of \$2 a year; outside of North America, \$3. Orders, accompanied by cheque or money orders payable to the Receiver General of Canada, should be sent to:

THE QUEEN'S PRINTER,
OTTAWA, Ontario,
Canada

Communications, other than those relating to subscriptions, should be addressed to:

EDITOR,
The Crowsnest,
Canadian Forces Headquarters,
OTTAWA, Ontario.

The Cover—The guard and band of HMCS *Naden* march off after having been paraded on the occasion of an official visit by His Honour G. R. Pearkes, VC, Lieutenant-Governor of British Columbia, to Rear-Admiral M. G. Stirling, new Flag Officer Pacific Coast. The English-ivy-covered walls in the background belong to the administration building in HMC Dockyard, Esquimalt. (E-78575)



RCN NEWS REVIEW

Symbolic of the move towards integration of Canada's armed forces is this three-service salute to ocean escorts of the Pacific Command as they returned to Esquimalt in November from Navy-Army-RCAF combined exercises. Saluting the returning warships are Major-General John Rockingham, General Officer Commanding Western Command; Rear-Admiral Michael G. Stirling, Flag Officer Pacific Coast, and Air Commodore R. C. Weston, Deputy Maritime Commander Pacific. (E-78667)

Trackers Join USN Carrier

On Sunday, Nov. 29, six Tracker aircraft from 880 Squadron under the command of the squadron commanding officer, Cdr. R. C. MacLean, took off from *Shearwater*, to become the last of four detachments to have operated from United States Navy carriers this year.

The aircraft underwent a one-week period of anti-submarine exercises, operating from the United States carrier *Essex*.

Trackers from VS 880 flew from the decks of U.S. carriers during the summer period while HMCS *Bonaventure* was undergoing refit in Saint John, N.B.

This last detachment completed the valuable series of missions with the United States Navy that has enabled the RCN to maintain its Tracker crews in a high state of operational readiness.

Three Officers Go to Viet Nam

Three RCN officers, one of them the first naval surgeon from Canada to serve in that part of the world, have been appointed to Viet Nam.

Lieutenant-Commanders Robert J. Paul and Douglas B. Babineau have taken up appointments with the mili-

tary component of the Canadian delegation in Saigon, Viet Nam, for duty with the International Commission for Supervision and Control.

Two Canadian naval officers participate continuously in this international commitment on annual rotation.

Lt.-Cdr. Paul was formerly Staff Officer (Reserves) to the Commodore Personnel Atlantic, at Halifax, and Lt.-Cdr. Babineau was RCN Area Recruit-

ing Officer, South Ontario Area, at Windsor.

The third officer, Surgeon Lt. Gerard A. St. Hilaire, of Sillery, Que., was to take up an appointment early in the New Year in Saigon on the Canadian truce team with the International Control Commission—the first such appointment for a Royal Canadian Navy doctor. He relieves F/L. J. L. J. M. Cote, RCAF, who is another native of Sillery.

Season's Greetings from Chief of the Defence Staff

Season's greetings were extended to the members of the Canadian Armed Forces and their families by Air Chief Marshal F. R. Miller, Chief of the Defence Staff, in the following message:

ON THIS the first Christmas of the new Canadian Defence Forces Headquarters, it is a particular privilege for me to extend the very best wishes for a full and happy Christmas to every Canadian sailor, soldier and airman and their families, wherever they may be serving.

I am confident that we in the Services will go forward into 1965 with a high resolve that our responsibility—the defence of Canada—will be met with all our dedication and energy.

Again, to all a Merry Christmas and a Happy New Year.

Surgeon Lt. St. Hilaire has served in medical appointments at HMCS *Shearwater* and on board the destroyer escort *Yukon*, where he was squadron medical officer for the First Canadian Escort Squadron at Halifax.

Officer Needs

Subject of Study

Major-General W. A. B. Anderson, until recently the Canadian Army's adjutant-general, has been named head of a staff group which will conduct a study on the officer requirements of the Canadian Armed Forces, it was announced in mid-November by Hon. Lucien Cardin, Associate Minister of National Defence.

The study is the most exhaustive of its type ever conducted within the Department. Its aim is to determine the essential educational, training and other qualifications for various ranks and categories and, by relating these to educational and training costs, to produce an economically sound and effective personnel plan to meet the long-term officer requirements of the Armed Forces.

Other officers in the staff group are Commodore R. L. Hennessy, Air Commodore R. M. Cox and Colonel J. M. Houghton.

The group's findings and recommendations will be submitted to the Minister by May 1, 1965.

A similar study for other rank requirements will be conducted at an early date by the Personnel Branch of Canadian Forces Headquarters.

Russian Research

Ships at Halifax

Two ships of the hydrographic service of the Soviet Navy arrived in Halifax Dec. 4 for a five-day replenishment period.

The ships were the *Polyus* and *Nikolaj Zubov*. They carry 25 naval officers and 220 civilians, including scientists.

The ships have been conducting hydrographic and oceanographic work in the western Atlantic.

For their stay in Halifax a program of scenic tours and visits of the area was arranged.

Captain Boggild

CO of Provider

Captain Kai Hugh Boggild was appointed commanding officer of HMCS *Provider*, the Royal Canadian Navy's operational support ship, based at Halifax, effective Dec. 8.

He succeeds Captain Thomas Charles Pullen who was appointed to the staff



In a manner that typified the ship's operations, Captain T. C. Pullen, commanding officer of HMCS *Provider* since she was commissioned in September 1963, left the fleet replenishment ship on Dec. 7 by jackstay transfer and landed on Jetty One at Halifax without a bump on his way to take up an appointment at Canadian Forces Headquarters on the Staff of the Chief of Operational Readiness as Director of Maritime Operations. (HS-76893)

of the Chief of Operational Readiness at Canadian Forces Headquarters as Director of Maritime Operations effective Dec. 12.

Captain Boggild was born in Norfolk, England, Nov. 2, 1920, and moved to Canada with his family in 1928. He entered the Navy as an ordinary seaman in September 1940 and was commissioned as a probationary sub-lieutenant in May 1942. He transferred to the regular force in October 1945.

Since the war, Captain Boggild has served on both coasts and at Naval Headquarters. In August 1957 he was appointed in command of HMCS *Reso-*

lute (coastal minesweeper) with the additional appointment of Commander, First Canadian Minesweeping Squadron. He later took command of HMCS *St. Croix* (destroyer escort) when the ship commissioned at Sorel, Que., in October, 1958. He has been serving on the staff of the Chief of Operational Readiness.

Captain Pullen was born in Oakville, Ont., May 27, 1918, and entered the Royal Canadian Navy as a cadet in 1936.

After early training in the Royal Navy, he joined HMCS *Assiniboine* (destroyer) at the outbreak of the Second World War. He became a gunnery

specialist and, as executive officer, survived the torpedoing of the destroyer *Ottawa* in September 1942. Later he was executive officer of the destroyer *Chaudiere* and then commanded HMCS *Saskatchewan* (destroyer) before the war's end.

In addition to staff and shore appointments in postwar years, he commanded the destroyer *Iroquois* and the frigate *La Hullose*. He was in command of HMCS *Huron* in the Korean war theatre and for part of this period was Commander Canadian Destroyers Far East.

He commanded the Arctic patrol ship *Labrador* on her 1956 and 1957 voyages to the Arctic after which he attended the Imperial Defence College and then became executive officer of HMCS

Niobe, RCN establishment in London, England.

He commanded HMCS *Shearwater*, RCN air station, from July 1960 to October 1962, at which time he was appointed to stand by the *Provider* during her final stages of construction at Lauzon, P.Q. Captain Pullen took command of HMCS *Provider* on her commissioning in September 1963.

Six Promoted To Commander

Six officers of the Royal Canadian Navy have been promoted to the rank of commander from lieutenant-commander, it was announced by Canadian Forces Headquarters. They are:

Cdr. Robert L. Hughes, Ont., officer-in-charge of the Operations and Weap-

ons Division, Fleet School, HMCS *Naden*.

Cdr. J. W. Fisher, Service Conditions and Welfare Officer in the Atlantic Command, Halifax.

Cdr. George McMorris, Chief Staff Officer (Plans) to the Maritime Commander Pacific, Esquimalt;

Cdr. John L. Cohrs, Canadian Forces Headquarters, Ottawa;

Cdr. N. R. Banfield, Staff Officer (Electrical) to the Naval Member, Canadian Joint Staff, Washington, D.C., and

Cdr. John A. Williams, officer-in-charge of the Academic Division Fleet School, HMCS *Stadacona*, and Staff Officer Academic Training to the Commodore Personnel Atlantic Coast, Halifax.

RCN SHIPS SEARCH STORMY SEAS

A SUDDEN WINTER STORM shrieked over the Canadian Atlantic seaboard at the beginning of December leaving in its wake marine disasters large and small. The Royal Canadian Navy figured prominently in the search and rescue for this, the biggest storm in the history of seafarers "down east".

The storm dumped up to 20 inches of snow in New Brunswick and more than three inches of rain in Nova Scotia. Winds gusted close to 100 miles an hour and waves built up to 50 feet.

Just before the storm broke, the destroyer escorts *Terra Nova* and *Gatineau* quelled a fire in the fishing vessel *Primo* on the night of Nov. 30 about 25 miles east of Halifax. One crewman had been trapped and died in the fire but the *Terra Nova* took off five survivors from the Lunenburg-based *Primo* and brought them to Halifax. Ten others remained with the fishing vessel, which was towed to port.

Air Chief Marshal F. R. Miller, Chief of Defence Staff, commented on the rescue in the following message to the Maritime Commander, Atlantic Rear-Admiral W. M. Landymore:

"The manner in which the forces under your command answered the distress call of the trawler *Primo*, were directed to the scene by air-sea co-operation, extinguished the fire on board the trawler and transported the injured man to Halifax reflects great credit on the Canadian Armed Forces. Congratulations to all who took part in the operation on a job well done."

Hard on the heels of the *Primo* affair, the *Gatineau* and *Terra Nova* plunged through heavy seas in the Cape Sabel

area, seeking the two-man lobster vessel *Jane and Judy*. The ocean escort *Cap de la Madeleine* later joined other ships in the search for the boat and at one time 16 RCN and RCAF aircraft were in the search for the lobsterman and others. The *Cap de la Madeleine* found the lobster boat overturned on the Roseway bank off Yarmouth on Dec. 3 but there was no sign of the two crewmen.

Rear-Admiral W. M. Landymore, Flag Officer Atlantic Coast, announced to the ships and RCN-RCAF air elements that the *Cape Islander* had been located, capsized with no sign of life, by the *Cap de la Madeleine*, and ended his message with these remarks:

"Although the conclusion of the search is not a happy one due to the apparent loss of life, ships and aircraft that participated in the search are to be congratulated on a task conducted in the true traditions of the sea and air and for the most part under the most appalling weather conditions. Well done."

The *Cap de la Madeleine* also joined the search for the 138-foot trawler *Acadia Sea Hawk*, out of Mulgrave, N.S., with 14 persons on board and Navy aircraft continued in the aerial force fanning out over the abating seas. On Dec. 7 the *Swansea* was diverted to relieve the *Cap de la Madeleine* but found only debris in the water about 80 miles southwest of Sable Island. There was debris, too, 200 miles east of Canso, N.S., where the 82-foot dragger *Marie Carole*, out of Grindstone, Magdalene Islands, was feared to have gone down with her crew of five.

The search involved Navy and RCAF planes, along with RCN, Coast Guard,

survey, merchant and fishing vessels, and was described by the RCAF Search and Rescue Co-ordination Centre as "the largest conducted in Canadian waters in recent memory."

Naval aircraft from *Shearwater* were airborne looking for the Liberian freighter *Fury*, which ran aground near Wedge Island some 95 miles east of Halifax. They found all 18 crew members of the 3,500-ton freighter scrambling off the reef to safety ashore. The Greek freighter *Arios Nicolas III* went aground at Sea Cow Head near Summerside, P.E.I. The 28 crewmen in the 3,500-ton freighter were safe.

The West German freighter *Elisabeth Schulte*, anchored a mile off Cape Blomidon, had her 1,100 tons of lead concentrate shift, giving the 2,285-ton ship a list of 20 degrees. She too had to call for help. She was able to move to a safe haven, however.

In Charlottetown harbour, the 12,744-ton Norwegian tanker *Belfast* went aground on a mudbank and had to pump out part of her cargo after the storm to work free.

An estimated \$1 million worth of lobster traps along the Nova Scotia coast were destroyed and, near Yarmouth, a \$40,000 dredge sank after being broken from its moorings. At the Royal Nova Scotia Yacht Squadron a 50-foot, \$100,000 yacht was driven ashore. A British freighter, radio and radar knocked out in the storm, turned up in Sydney, N.S., a day and a half overdue. From here and there, word trickled back in of fishing vessels in far worse shape limping back into ports along the seaboard, but they made it in spite of Nature's wild outburst.

EXERCISE YEOMAN

CANADIAN LAND, sea and air forces, in conjunction with ground defence units of the U.S. Marine Corps at Argentia, Newfoundland, took part in an exercise centred on the U.S. Navy base at Argentia Oct. 25 to Nov. 8.

The exercise, designated "Yeoman", was scheduled by Rear-Admiral Jeffrey V. Brock, then Canadian Maritime Commander Atlantic, and Lieutenant-General R. W. Moncel, former General Officer Commanding Eastern Command, with the co-operation of Admiral H. P. Smith, Commander-in-Chief, U.S. Atlantic Fleet. Admiral Brock directed the exercise.

Exercise Yeoman was the third in a series of exercises designed to train regular units of the Canadian Navy, Army and Air Force in the Atlantic Provinces in certain aspects of combined operations. The first in the series, Exercise Boatcloak, was held in December 1963.

The exercise provided an opportunity for co-ordinated control of military forces for the purpose of defending Canadian territory and the facilities of the U.S. Naval base at Argentia. It also introduced participation by the Royal Canadian Mounted Police in operations of this nature.

The U.S. Marine Corps detachment at Argentia, which provides base security, conducted a concurrent internal security exercise, designated "Exercise Counterpart", in support of the Canadian operation.

Ten ships of the RCN's Atlantic Command and about 450 Army personnel from the Third Canadian Infantry Brigade Group at Gagetown, N.B., took part in the exercise.

Army personnel were embarked on board ocean escorts of the Seventh and Ninth Escort Squadron on Oct. 29. Units involved were HMC Ships *Fort Erie*, *Inch Arran*, *New Waterford*, *Victoria-*



The Navy gives the Army a lesson in ship-board gunnery. (HS-76524-13)

ville, *Cap de la Madeleine*, *La Hullose*, *Buckingham*, *Outremont* and *Lanark*.

HMCS *Provider* earlier sailed for Saint John, N.B., where she embarked more than 100 vehicles and their drivers, then departed to rendezvous with the ocean escorts off Halifax.

The ships arrived at Argentia Nov. 1 and immediately began unloading. Army personnel then took up positions along the perimeter of the U.S. base.

Two RCAF T-33 jet aircraft provided air support for the Army force. An Army helicopter provided spotting and reconnaissance assistance.

Hon. Lucien Cardin, Associate Minister of National Defence, accompanied by Lt.-Gen. J. V. Allard, Chief of Operational Readiness, Air Commodore C. G. Ruttan, Director General Operations, Brigadier H. E. T. Doucet, executive assistant to Mr. Cardin, and other observers from Canadian Forces Headquarters visited the exercise area.

The minister and his party were escorted on a tour of the exercise facilities by Rear-Admiral Brock and Major-General G. A. Turcot, General Officer Commanding, Eastern Command.

Chief controller for the exercise was Commodore J. C. O'Brien, Senior Canadian Officer Afloat (Atlantic), who had his headquarters in a bunker base which was dubbed "Der Scruffenbunker," and was identified with a large sign at the entrance and featured German music inside.

Army personnel taking part in the exercise were under the command of Lt.-Col. M. L. A. Chabot, acting commander of 3 CIBG and officer com-



Rear-Admiral Jeffrey V. Brock, then Flag Officer Atlantic Coast, followed by Air Commodore C. G. Ruttan, Director General Operations, and Major-General G. A. Turcot, General Officer commanding Eastern Command, trudge uphill to the defence force control headquarters outside the U.S. Naval Base at Argentia, Newfoundland, during Exercise Yeoman.



HMCS Provider with army equipment on board. (HS-76524-20)



Hon. Lucien Cardin, Associate Minister of National Defence, and his official party make their way to the control headquarters of friendly "Blue-land" forces during Exercise Yeoman, which was centered on the U.S. Naval Base at Argentia, Newfoundland.

manding the 1st Regiment Royal Canadian Horse Artillery.

The 1st Regiment, Royal Canadian Horse Artillery, supplied a full field battery, less guns and headquarters staff, with the 1st Battalion, the Black Watch, providing an infantry company.

The 2nd Field Squadron, Royal Canadian Engineers, and the 3rd Signals Squadron, with supply staff from the 3rd Brigade Service Battalion, made up the remainder of the Army component.

The main objective of Exercise Yeoman was to transport by sea sufficient Army personnel and equipment to practise protection of military installations in certain Canadian areas.

Other objectives were to practise the Army forces and ships in problems of naval logistic support of land forces; problems associated with loading and unloading; approach and landing, and tactical employment of air support, including photo reconnaissance.

For purposes of the exercise, the Avalon Peninsula of Newfoundland was designated "Blueland".

A year ago, according to the program of the exercise, Blueland enacted a 30-mile fishing limit in its offshore waters from which Orangeland had traditionally done most of its fishing. Orangeland had attempted without success to plead its case before the United Nations.



A light snowfall added to the realism (and discomfort) of Exercise Yeoman. (HS-76524-52)

Blueland maritime patrol forces were recently instructed to check more closely for infractions of the new limit, which, in turn, triggered more flagrant violations. The Orangeland fishing fleet had

been growing in size and concentrating its operations just off the south and east coasts of Blueland.

In the last several weeks more and more reports of Orangeland trawlers being sighted close inshore in various bays and inlets led to an increasingly anxious situation.

No reported landings had occurred but it was considered very likely that minor clandestine raiding parties might well be put ashore on nuisance raids in an attempt to bring the whole question of fishing rights to a head.

The U.S. Naval Base at Argentia, being the major military target, was considered the most attractive and available target for such raids.

The Blueland government had directed that prudent measures be taken and the Maritime Commander Atlantic established a force to meet the situation.

For the exercise, the force consisted of about 30 officers and men from the 3rd Canadian Infantry Brigade Group, who were transported and landed by RCN auxiliary vessel. This raiding party was to attempt to work its way overland and sabotage the U.S. Naval station at Argentia. This force also included an RCN diving team and a tender.

The defence forces were joined by 175 U.S. Marines and USN personnel who took to the field to work in cooperation with Canadian land, sea and air forces.



Hon. Lucien Cardin, Associate Minister of National Defence, followed by Major-General G. A. Turcot, General Officer Commanding Eastern Command, emerging from a briefing in the Scruffenbunker—the exercise Yeoman control centre. The name "Scruffenbunker" was explained by Commodore J. C. O'Brien, Senior Canadian Officer Afloat (Atlantic) and senior controller for the exercise. The label derives from a Navy nickname of long standing.

On completion of the exercise, Major-General Turcot sent the following message to Canadian and U.S. forces who participated:

"Congratulations to all ranks on the successful completion of Exercise Yeoman.

"As one of my first duties as GOC Eastern Command it was a pleasure to visit this combined operation and to see the enthusiastic spirit of this third in a series of joint exercises which are pro-

viding rewarding and worthwhile training. Much valuable experience has been gained and many valuable lessons have been learned for future combined operations exercises.

"Much of the successful exercise setting and development was due to the spirited co-operation of the U.S. forces and I would like to thank and congratulate them on their performance.

"Once again, my congratulations on a job well done."

CANLEX '64

THE NORTHERN TIP of Vancouver Island was "invaded" during the first week of November by members of Canada's three armed forces, including units from Victoria, Comox, Chilliwack, Rivers and Calgary.

The three-service exercise, labelled "Canlex 64", saw the First and Second Battalions of the Queen's Own Rifles of Canada (of Victoria and Calgary respectively) transported to the rugged island area in four ocean escorts of the RCN's Pacific Command. Aircraft of the RCAF, from stations at Comox, on Vancouver Island, and Rivers, Manitoba, were used to transport the Calgary army personnel to and from the West Coast, and to serve requirements in the exercise area. Also participating were personnel of 3 Field Squadron, Royal Canadian Engineers, from Chilliwack.

Under the overall direction of Major-General J. M. Rockingham, General Officer Commanding Western Army Command, Canlex 64 was designed to test inter-service operations and prepare personnel for co-ordinated action in such rough terrain.

Assisting in the direction of the exercise were Rear-Admiral M. G. Stirling, Flag Officer Pacific Coast, and Air Commodore R. C. Weston, Deputy Maritime Commander Pacific, senior air officer of the Pacific coast.

Focal point of the exercise was an RCAF radar station, located in the heavily wooded and mountainous region at the northern tip of Vancouver Island.

As Canlex unfolded, "enemy" forces captured the radar site. To the "friendly" force fell the task of reclaiming the target. It was a gruelling job. Rain was heavy and almost continuous. Soldiers had to fight their way through dense underbrush, or slog along rough and treacherous logging roads. It presented compounded challenges in such activities as embarkation drills, communications, naval fire support, aerial reconnaissance, small boat landings, and maintenance of supply lines.

The soldiers used FN rifles, .30 calibre machine guns and sub-machine guns. Thunder flashes were used to simulate grenade explosions.

Support fire for the troops was provided by the ocean escorts; T-33 jets of the RCAF simulated air-to-ground strafing operations.

Nearly 500 Navy, 200 Army and 50 RCAF personnel participated in Canlex 64, the first large-scale tri-service exercise in Western Canada since integration of the armed forces was announced.

The Second Battalion of the QOR of C (enemy force) was under the command of Captain Neil C. Pearce, member of the Queen's Own Buffs, of Churt, Surrey, England, on exchange with the "Queen's Own" for two years in Calgary.

In command of the First Battalion, with headquarters at Work Point Barracks, Victoria, was Major Charles Belzile.

The exercise got under way through Oct. 30-31 when HMC Ships *Jonquiere*, *Sussexvale*, *Stettler* and *Antigonish*, all units of the RCN's Fourth Canadian Escort Squadron based at Esquimalt embarked the troops at Esquimalt and Patricia Bay.

When not engaged in providing supplies or naval gun-fire support, the naval ships conducted manoeuvres in the adjacent Scott Islands area.

With both friendly and enemy troops embarked, the warships returned to Esquimalt Harbour on the late afternoon of Nov. 5.

As a fitting climax to the exercise, a return salute to the incoming ships was given by the senior officers of the three services in Western Canada: Rear-Admiral Stirling, Major-General Rockingham and Air Commodore Weston. They stood side by side on the saluting base overlooking the approaches to the naval base.

The naval band of HMCS *Naden* provided a musical welcome as the ships secured at their jetties in HMC Dockyard.

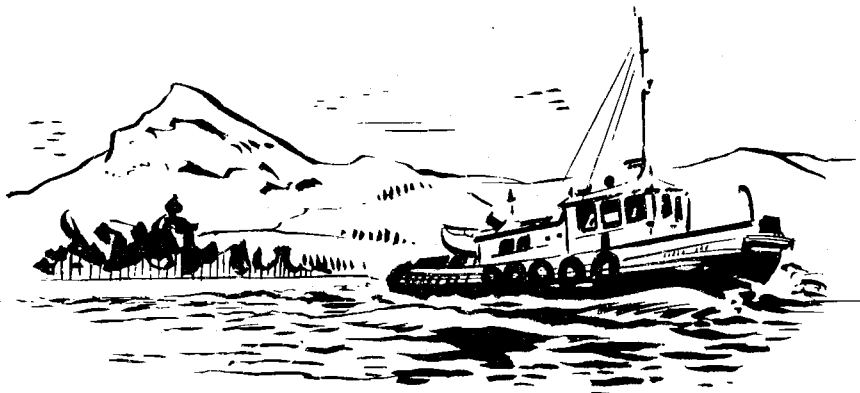

OFFICERS AND MEN

Centre Marks 10th Anniversary

Victoria's Armed Services Centre celebrated its 10th anniversary at the annual directors' luncheon on Oct. 20.

The luncheon was held in the ward-room mess of HMCS *Naden* and Lieutenant Governor George Pearkes, VC, was the guest of honour.

The chief aim of the centre is the integration of sailors, soldiers and airmen with community life. It provides a meeting place where servicemen can entertain civilian friends in a pleasant, informal atmosphere.

It is equipped with recreational facilities, a lounge, canteen, lockers and shower room. There are desks and writing materials and an array of comfortable and brightly coloured chairs.

Servicemen can watch TV, play cards or cribbage, entertain friends and keep their civilian clothes in lockers for a nominal fee.

"We believe the centre contributes a great deal to the excellent relationship existing between members of the armed services and citizens at large," says E. E. Pearlman, QC, president.

The luncheon was also a farewell to Rear-Admiral W. M. Landymore, then Flag Officer Pacific Coast, who was being transferred to Halifax as Flag Officer Atlantic Coast.

"We all appreciate his tireless leadership and effort in promoting co-operation and understanding between the services and the community," wrote Rear-Admiral J. C. Hibbard, RCN (Ret), an executive director of the centre.

RCN Officer Has Share in Rescue

For their rescue work in hoisting eight persons from the stricken Norwegian tanker *Stolt Dagali* on board their helicopter, two members of the U.S. Coast Guard and a Canadian naval officer received a "certificate of meritorious service" from the Sons of Norway, Long Island zone, on Dec. 3.

The presentation was made during an inspection ceremony at the U.S. Coast Guard air station, Floyd Bennett Field, Brooklyn, by Kjewl W. Pettersen, general chairman of the Sons of Norway.



This was Shearwater's own Trans-Canada Hit Parade during the football season, Wrens Patricia Hucul (Vancouver), Beverly Morris (Toronto) and Gerry Katelnikoff (Regina), in the top row, and Wrens Roberta Ollitt (Victoria), Margaret Diplock (Edmonton) and Sharon McKay (Harding's Point, N.B.), in the lower row.

The helicopter which effected the rescue was piloted by Lt. Walter E. (Mike) Mason, Jr., USCG, of Massapequa Park, N.Y., with Sub-Lt. James L. Lewis, RCN, from Grand Forks, B.C., as co-pilot. The Coast Guard aircrewman was Aviation Structural Mechanic Second Class Eugene G. Brauer, of East Meadow, N.Y.

Although one Norwegian seaman was dead on arrival at the Point Pleasant, New Jersey, hospital, the helicopter had the distinction of rescuing the greatest number of survivors, seven, in the dis-

astrous collision between the Israeli luxury liner *SS Shalom* and *MV Stolt Dagali*.

Lt. Mason took off with his helicopter about 5.15 am. It was still only twilight when he arrived on the scene and saw a U.S. Navy helicopter hoisting survivors from a swamped lifeboat. The Coast Guard helicopter then moved into position and hoisted two persons aboard, one apparently dead, the other in a state of shock and hysteria. Sub.-Lt. Lewis had to help Crewman Brauer pry the fingers of the hysterical seaman loose from the rescue basket.

Because of the man's condition, the helicopter flew directly to the hospital and then back to the bow section of the tanker and removed six Norwegian seamen—a load that it was only possible for the helicopter to carry because its fuel was running low.

The survivors were flown to the naval air station at Lakehurst, N.J., where the helicopter was refueled. The search was resumed but the malfunction of a fuel pump forced the machine to return to its home station after a total of seven hours on the rescue mission.

Sub-Lt. Lewis reported to the Coast Guard air station last May as a participant in an aircraft pilot training program arranged between the U.S. and Canadian governments.

Ships Pay Visits To Vancouver

Seven ships of the Pacific Command were in Vancouver during late November in connection with routine training exercises.

Six ocean escorts of the Fourth Canadian Escort Squadron were at the mainland city from noon Friday, Nov. 20, until the following Sunday morning. They were HMC Ships *Sussexvale*, *Beacon Hill*, *Jonquiere*, *New Glasgow*, *Antigonish* and *Stettler*. Under Captain E. P. Earnshaw, squadron commander, the ocean escorts returned to Esquimalt on Sunday afternoon, Nov. 21.

Also in Vancouver was the destroyer escort HMCS *Ottawa*, commanded by Cdr. J. P. Cote. The ship left Esquimalt on Nov. 19 and was in Vancouver for two days.

New Captain for Cap de la Madeleine

Lt.-Cdr. Francis J. P. French has taken command of the ocean escort *Cap de la Madeleine*, based at Halifax. He was previously in command of a sister ship, the *Lanark*.

Sailors Fail In Rescue Bid

Last summer saw two young sailors from HMCS *Bonaventure* participate in a courageous but unavailing attempt to rescue a drowning man in Halifax harbour.

AB Robert Marshall and AB John Gladden were on a flight deck of the carrier, secured near the Halifax end of the Angus L. Macdonald bridge, when they heard a splash and learned that a man had fallen from the bridge.

The sailors ran down three decks, shedding excess clothing as they went,



AB R. MARSHALL

AB J. GLADDEN

and dropped into the harbour. They swam a quarter of a mile before they found the man floating in the harbour, apparently unconscious. Marshall who has a bronze medal in life-saving, grasped the man by the head and Gladden helped to support him.

The naval fire tug came to the scene and lifted the man on board. A naval ambulance took him to the Canadian Forces Hospital, but he was found dead. He was identified as a resident of Parrsboro, N.S.

The two seamen returned to their ship thoroughly chilled. Water temperature of the harbour that day was 46°F.

Course Officers Visit Canada

Thirteen senior naval officers from 12 nations toured Canadian naval and commercial installations from Oct. 16 to 23.

The officers are taking a United States Navy supply management course for senior foreign officers in Washington, D.C. Purpose of the course is to acquaint officers from other nations with USN supply methods. A visit to Canada is regularly included in the course itinerary.

Countries represented are Belgium, Brazil, Canada, Republic of China, Denmark, Federal Republic of Germany, Japan, Korea, the Philippines, Spain, Turkey and Viet Nam.

Officer Dined At Cornwallis

On the last day of his 23 years of service with the medical branch of the RCN, Lt.-Cdr. Thomas A. Kadey was tendered a mess dinner at HMCS *Cornwallis* on Sept. 3. Lt.-Cdr. Kadey, a medical administrator, will be released on March 22, 1965.

He joined the RCNVR in 1941 at HMCS *Tecumseh*, the Calgary naval division, as a probationary sick berth attendant and transferred to the RCN in December 1945. Since then he has served in establishments from St. John's,

Nfld., to Victoria, B.C. His last appointment was as medical administrator at the hospital at *Cornwallis*.

Naval personnel who have served in those localities will remember Lt.-Cdr. Kadey as organist in the naval chapels at Victoria, Halifax and Cornwallis. His great interest in music and choral work also led to his participation in musical shows in various parts of Canada.

Personnel Post to Commodore Edwards

Commodore Gordon C. Edwards has been promoted to that rank and appointed to succeed Commodore Ralph L. Hennessy as Commodore Personnel Atlantic Coast with headquarters at HMCS *Stadacona*, Halifax.

Commodore Hennessy has been appointed to Canadian Forces Headquarters in Ottawa.

Commodore Edwards, who for the past two years has been commanding officer of RCN Air Station *Shearwater*, has been succeeded by Captain D. H. Patrick Ryan, who has been promoted to that rank. Captain Ryan commanded the destroyer escort *Kootenay*, based at Halifax, for the past two years.

Rotarians Visit Royal Roads

Some 20 members of the Chemainus Rotary Club toured the Canadian Services College, *Royal Roads*, on the evening of Oct 28.

During the tour the Rotarians visited the various academic and athletic facilities of the college, as well as the castle where the college administration offices are located.

Rank Confirmed For Commodore

Acting Commodore J. W. Goodchild, Senior Naval Officer, Toronto Area, was confirmed in rank Nov. 1. He held the acting rank from taking up the appointment in June 1962.

Commodore Goodchild joined the former RCNVR in 1941 as a writer and was commissioned in 1942. Demobilized in 1946, he graduated in law from Toronto's Osgoode Hall in 1949 and entered the active list of the RCNR at HMCS *York* two years later. By July 1958 he was in command of the Toronto naval division.

In 1962 he succeeded Commodore R. I. Henty as Senior Naval Officer, Toronto Area, and was granted the acting rank of commodore on taking up the new appointment.

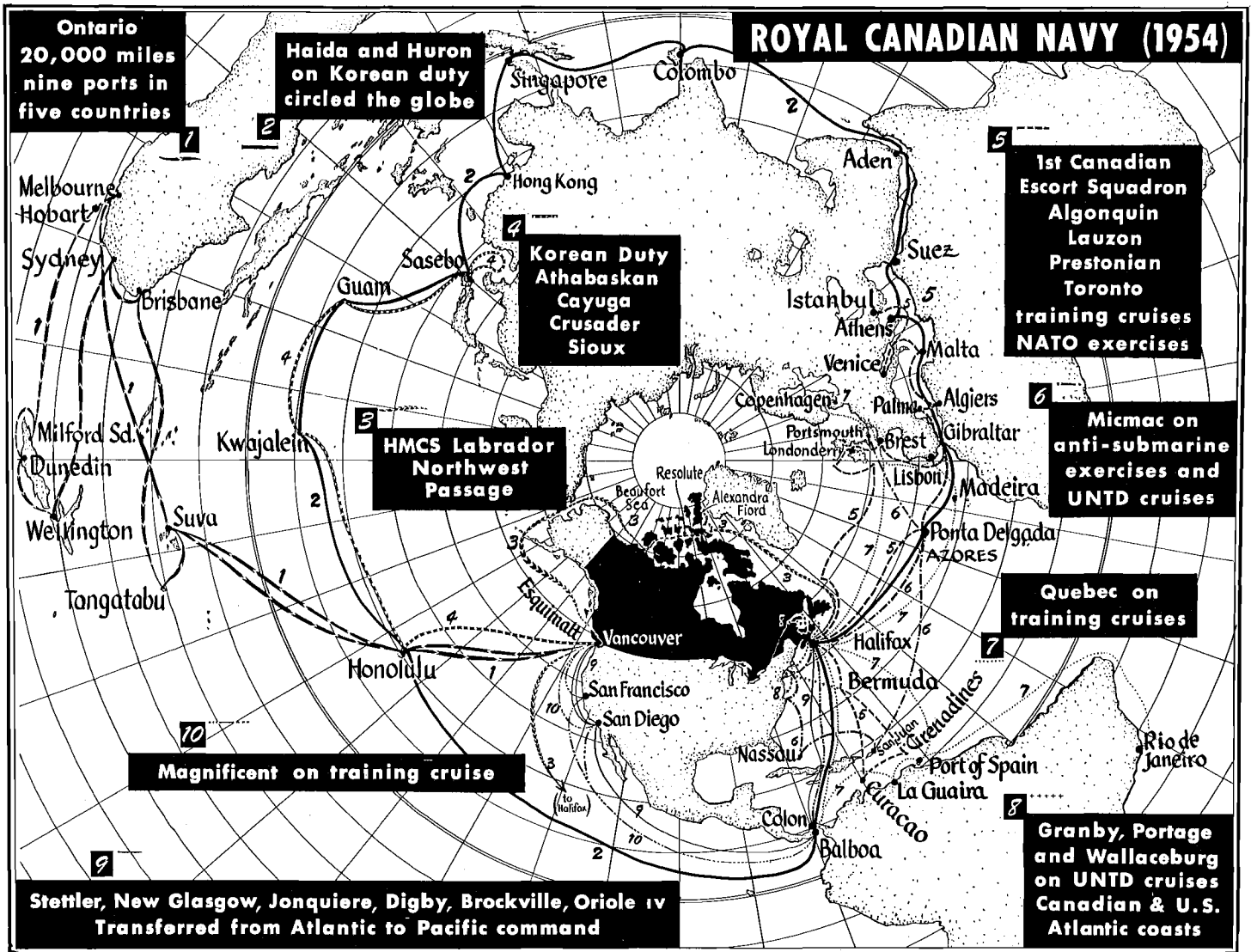

THE POSTWAR evolution of the Royal Canadian Navy is illustrated—and a certain amount of nostalgia may be aroused—by the accompanying chart, which shows the far-ranging activities of the fleet 10 years ago.

Then the RCN had two training cruisers, HMC Ships *Ontario* and *Quebec*, which roved the world on training and goodwill missions. That was the year that HMCS *Labrador* became the first big ship to complete the Northwest Passage. She also circumnavigated the North American continent.

Although the guns had ceased to fire on July 27, 1953, Canadian destroyers were still patrolling Korean waters. Six saw service there that year and two of them, the *Haida* and *Huron*, returned home by way of Suez to encircle the globe.

Seven ultra-modern destroyer escorts were a-building for the RCN, but it was not until the autumn of 1955 that the first one, HMCS *St. Laurent*, was commissioned and another eight years before she was converted into a helicopter-carrying submarine hunter—the next step in the Navy's evolution.

Two dozen ships are named on the drawing. Of these, only six fighting ships and one training vessel

remain in service—evidence of the modernization the fleet has undergone in the past decade. Still with the RCN are the *Algonquin*, *Athabaskan*, *Granby*, *Jonquiere*, *New Glasgow*, *Stettler* and the little training yacht *Oriole*.

Excellent training ships though they were, the cruisers *Ontario* and *Quebec* did not meet the operational requirements of the new anti-submarine navy and did not long survive the coming of the new destroyer escorts.

The *Labrador*, perhaps the finest Arctic research vessel afloat, proved a luxury to the new Navy and, to help the RCN meet the manning requirements of its new ships, was transferred to the Department of Transport, with which she still serves.

The Tribals which were on the go in 1954 did a little better, serving throughout most of the ensuing decade. But now only the *Athabaskan*, the youngest of the class and completed in 1948, remains in service. One of the most famous of the RCN's fighting ships, HMCS *Haida*, was paid off in 1963 and acquired by a group of admirers. She is being preserved as a memorial at Toronto.

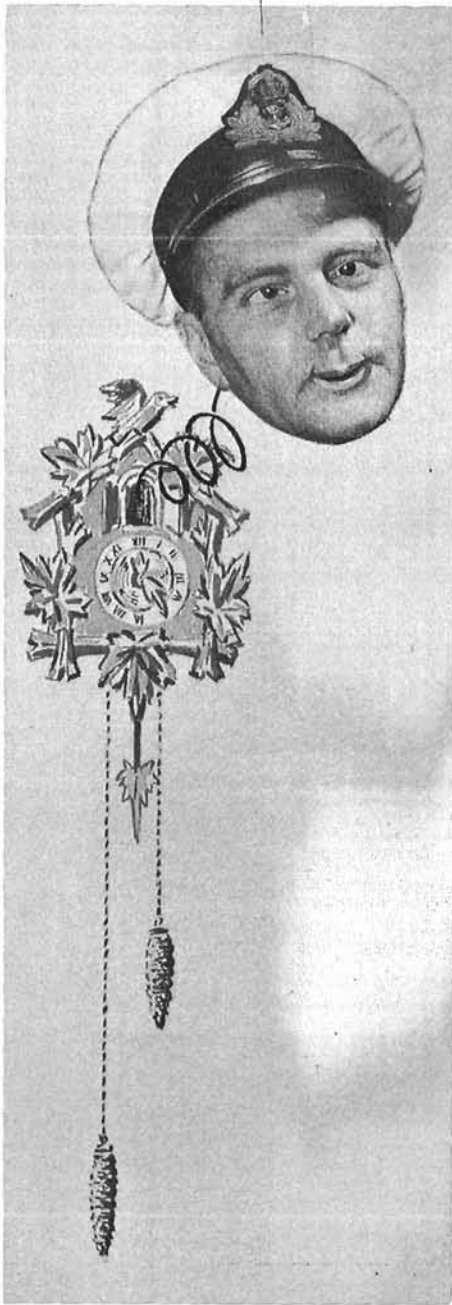

CUCKOO! CUCKOO!

How Not to Buy a Clock

The last afternoon. No cuckoo clock. Time was running out. And Charlie very busy. He had heard I was going ashore on business and mentioned his problem. Sure. No problem, I'd be glad to help.

Me and my big mouth.

Some time ago son Rick shared vital knowledge: "Two things are almost impossible, Dad," he advised, "getting toothpaste back into the tube and making a worm stand up on end."

Now I can add to that list. It is also impossible to get a cuckoo clock in Japan—when you don't speak a word of Japanese and the people in the shops don't understand a word of English.

Scene one: It was a large department store, one of many in Tokyo. I had found the watch and clock department, but there was no visible evidence of the cuckoo variety. First one young lady, then another. Hopeless. They beckoned an elderly man to the counter. I tried to get the message over.

Cuckoo! Cuckoo! I pointed to my wrist watch. Cuckoo! Cuckoo! Used a hand to demonstrate a bird popping out of a clock (my head), and opening and shutting it like the beak of a bird. The elderly man just looked with mixtures of doubt and utter fascination. And grinned. Other sales personnel and some other customers started to cluster around us. I didn't have to wonder what they were thinking. It was all pretty obvious. They too were all grinning.

Finally the elderly man at least latched onto the word. "Cuckoo," he said, with apparent pride. He repeated the new-found word with ever-increasing grins.

I relaxed. Maybe this was it. I'd get the clock after all.

Not so. On a small piece of wrapping paper he put down some Japanese words, or symbols, or something, then led me to the door and pointed down the street. He was saying something like "Cuckoo, cuckoo" as he returned to his counter.

Scene two: A small shop nearly two blocks away, with windows full of souvenir-type things. Hopeful of victory here, I marched in and confidently placed the piece of paper on the counter. A middle aged lady gave it some concentrated study. Then gave me some equally concentrated study. Then she started to laugh. What was written on that piece of paper, I don't know, but my suspicions were running high. With hopes on that magic piece of paper completely dashed, there wasn't much point in continuing the search there. I left.

Scene three: Another large department store some distance away, and which I had visited two days earlier and had remembered seeing clocks. Same routine. Same problem, I cuckoo'ed" up and down the scale to the delight of all within sight and hearing. Went through the same ridiculous antics and got the same big grins in exchange.

Then a bright idea. On a piece of notebook paper I sketched a rough outline of what I was after. The bird in the drawing looked more like a sick duck, but it did the trick.

The young salesman beamed. I beamed. Everybody beamed. To me it was the start of National Beam Week in Japan. I got the clock. Mission accomplished.

Maybe, some day, our ship will return us to Japan. I'm going to ask Charlie to get me a fly-swatter.—R.W.



THE NEXT TIME Charlie Jessop wants a cuckoo clock he can go to their Vaterland and get one from the elves in the Black Forest.

It happened in Tokyo. Charlie (that's Lt. Charles Jessop) was up to his ears in paperwork, nothing new for the busy secretary to the squadron commander.

His ship, the *Fraser*, with HMCS *Mackenzie*, was on the fourth and final day of a visit to the great capital of the Land of the Rising Sun. Four months earlier he had promised his wife he would return from the Far East with a cuckoo clock. Tokyo was his last chance. From there the two destroyer-escorts would steam for their home base at Esquimalt.

NEW SURGEON GENERAL

SURGEON REAR-ADMIRAL Timothy Blair McLean, Surgeon General of the Armed Forces since January 1960, proceeded on retirement leave on Oct. 7.

He was succeeded by Rear-Admiral Walter J. Elliot, Deputy Surgeon General (Personnel and Treatment Services), who was promoted to his present rank on taking up his appointment.

SURGEON REAR-ADMIRAL TIMOTHY BLAIR McLEAN, CD, RCN

Surgeon Rear-Admiral T. Blair McLean was born on a homestead near Legal, Alberta, on September 29, 1910. His family moved shortly afterward to Edmonton, where he attended public and high school and the University of Alberta, from which he obtained his medical degree.

Admiral McLean entered the RCNVR in September 1929 and served continuously in the naval reserve for the next 10 years. At the outbreak of the Second World War he was called to active service as a surgeon lieutenant.

During the early part of the war he served as medical officer in the destroyers *Ottawa*, *Saguenay*, *Fraser* and *Margaree*, surviving the sinking of the latter two. His services at the time the *Fraser* was lost were recognized with a mention-in-dispatches. For the balance of the war he served in various medical appointments ashore and as Principal Medical Officer of HMCS *Uganda* (cruiser).

In October 1945 Admiral McLean transferred to the regular force with the acting rank of commander. He was appointed Principal Medical Officer of the RCN Hospital at Esquimalt in March 1947 and in July was confirmed as a commander. In October 1948 he was appointed Command Medical Officer, Esquimalt.

Surgeon Rear-Admiral McLean began two years of further surgery training at the U.S. Naval Hospital, San Diego, California, in August 1950, after which he was appointed Deputy Medical Director at Naval Headquarters.

Two years later he returned to the west coast as Principal Medical Officer of HMCS *Naden* and Command Medical Officer.

He took up the appointment of Medical Director General of the RCN in September 1958. He was appointed Surgeon General of the Armed Forces and promoted to the rank of Surgeon Rear-Admiral in January 1960.

In April 1960 he was appointed Honorary Surgeon to Her Majesty, Queen Elizabeth II.

SURGEON REAR-ADMIRAL WALTER J. ELLIOT, CD, RCN

Surgeon Rear-Admiral Walter J. Elliot, CD, RCN, was born in Harrison Hot Springs, B.C., on Jan. 12, 1914. He studied medicine at Queen's University, Kingston, and graduated in 1937. Following his internship in the Kingston and Vancouver General Hospitals, he practised in Chemainus and Golden, B.C.

He was appointed ship's surgeon in the *Empress of Canada* in October 1939 and held this post until he entered the Royal Naval Volunteer Reserve in London, England, in July 1940.

He served as medical officer in Royal Navy escort ships on the North Atlantic until June 1942, when he transferred to the RCNVR and was appointed to HMCS *Naden*.

Admiral Elliot took post graduate training at the Sick Children's Hospital, Toronto, from October 1943 to July 1944 and for the balance of the war served in naval hospitals in Halifax, *Cornwallis*, Newfoundland and Esquimalt.

He transferred to the regular force in January 1946 and subsequently held

senior medical appointments on the west coast and at Naval Headquarters, Ottawa.

In July 1952 he was appointed for a two-year post graduate course in ophthalmology at the Philadelphia Naval Hospital, the University of Pennsylvania and Colby College. Following these courses, he was appointed Principal Medical Officer and ophthalmologist of the RCN Hospital in Halifax in September, 1954.

Two years later, he was appointed Principal Medical Officer in HMCS *Magnificent* and in March, 1957, became Principal Medical Officer in HMCS *Bonaventure*.

Rear-Admiral Elliot was appointed to the Venerable Order of Saint John of Jerusalem in the rank of Serving Brother in June 1957.

In December 1957 Admiral Elliot was appointed officer-in-charge of the Medical Branch School and ophthalmologist in the RCN Hospital at Esquimalt, with the acting rank of surgeon captain. He assumed the appointment of Principal Medical Officer and ophthalmologist of HMCS *Naden* and on the staff of the Flag Officer Pacific Coast as Command Medical Officer in August 1958.

In August 1960 he was appointed Assistant Surgeon General (Professional) at the National Defence Headquarters Medical Centre, Ottawa. He was promoted to commodore in April 1961 and was appointed Deputy Surgeon General (Personnel and Treatment Services), at that time.



Surgeon Rear-Admiral Timothy Blair McLean (left), who had served as Surgeon General of the Armed Forces since January 1960, proceeded on retirement leave in October and was succeeded in the appointment by Rear-Admiral Walter J. Elliot.

TEN YEARS AGO, on Nov 1, 1954, the Royal Canadian Navy's utility aviation squadron VU-33 "took to the skies" to begin its life as the small but hard-working West Coast unit of Canada's naval air arm.

A decade is not a long time in comparison with the 54-year history of Canada's navy, but a 10th anniversary still merits some observance.

Naval aviation in Canada didn't really come into being until 1946, with the acquisition of the aircraft carrier HMCS *Warrior*, although it can be traced back to the closing year of the First World War when the Royal Canadian Naval Air Service was formed on the east coast to carry out anti-submarine operations. The end of the war brought these first stirrings to a close. During the Second World War, two Royal Navy escort carriers were manned by Canadians, and while the aircraft and their crews were mostly British, some Canadians were among them.

While Canadian naval aviation is barely 20 years old, VU-33 can lay claim to having contributed in no small way to developments in this little-known field of Canadian naval activity.

VU-33 was formed at Patricia Bay Airport, 20 miles north of Victoria, from what was known as VS-880 West Coast Detachment, VS-880 being one of two operational aviation squadrons based on the east coast.

The new squadron was under the command of Lt.-Cdr. Douglas Fisher, who was responsible for the activities of two AS-3 Avenger aircraft and 24 officers and men. In 1956, two years after the squadron was formed, an additional aircraft, a C-45 Expeditor, was added.

In 1957, Lt.-Cdr. R. A. Shimmin took command of the squadron, which by now had grown to four officers and 50 men. A noteworthy achievement of the year was the winning of the RCN Safe Flying Trophy.

The year 1959 saw the addition of three HUP-3 Vertol helicopters, the only aircraft of their kind in the RCN. In 1960, the three Avengers were retired and replaced by CS2F-1 Trackers, a new and much more versatile anti-submarine aircraft. At the same time, one T-33 Silver Star jet aircraft was acquired for use as a high-speed target-towing and radio-alignment aircraft.

The squadron, grown to five officers and 60 men, was by now commanded by Lt.-Cdr. A. J. Woods.

Lt.-Cdr. S. E. Soward was appointed in command of VU-33 in 1961, to direct the activities of three Trackers, two T-33s and three HUP-3 helicopters.

VU-33

The squadron's present commanding officer, Lt.-Cdr. A. A. Schellinck, took command in 1963 when squadron strength reached its present six officers and 68 men.

The squadron's HUP-3 helicopters were retired from duty in February 1964, but not without having chalked up some successful search and rescue missions in coastal areas of the province. It was a HUP that made the first landing on the deck of HMCS *Assiniboine*, the first of the RCN's post-war destroyer-escorts to be converted to "helicopter handling capability" with the addition of a landing platform and hangar.

VU-33 was originally formed to provide torpedo and weapons dropping facilities during proving trials at the RCN Underwater Weapons Range. While this is still one of the squadron's activities, the tasks have been expanded to include target-towing and gunnery-alignment for ships of the fleet, aerial photography, proficiency flying for fleet pilots, advanced flying training for newly commissioned naval aviators, and air familiarization courses for squadron personnel, and for officers and men of the surface fleet whose duties relate to joint air-sea operations. The squadron also takes part in search and rescue operations when required.

VU-33 is not an operational squadron, but is used for the role that its name implies—utility. The squadron's pilots are all experienced personnel who have seen service in operational squadrons on board the aircraft carrier HMCS *Bonaventure* with various types of aircraft. The utility squadron could form the nucleus of a fully operational squadron if the need arose.



VU-33 has an additional role not normally assigned to naval air squadrons. It provides the necessary administrative and maintenance to function as a naval air facility, handling about 800 visiting aircraft a year ranging in size from jet trainers and jet fighters to the huge four-engined Yukon and Argus aircraft of the RCAF.

The squadron's activities at Patricia Bay Airport are widely varied and there is plenty of work to be done at all times. But it is very true that all work and no play makes Jack a dull boy, so the squadron makes sure that it is well represented in the Pacific Command sports picture. The squadron participates regularly in baseball, basketball and hockey tournaments. There is also some intra-mural baseball, volleyball and pistol shooting. The squadron has its own curling club and a small fish and game club. The squadron's curling team placed second in the RCN bonspiel last winter in Ottawa.

In addition, squadron personnel are active in Little League activities and Boy Scout work in the Sidney and Victoria areas. The men of VU-33 also contribute well to charity; 76 per cent of all profits from the squadron canteen is turned over to named charities.

In Hong Kong, a young Chinese boy named Liu Chung Wai is supported by the squadron through the Foster Parents' Plan.

VU-33 plays its part in the Pacific Command safe driving campaign, with more than half the squadron personnel having taken the safe driving course at HMCS *Naden*. The private cars of all personnel of the squadron must pass inspection by the RCMP before air station gates passes are issued, and all vehicles must also be adequately insured.

The facilities of VU-33 are located on the west side of the Victoria International Airport and consist of a large hangar with excellent workshops, a supply building stocking items ranging from nuts and bolts to aero engines, and an administration building. Adequate mess facilities are available for all personnel and married quarters are located on West Saanich Road. In fact, most of squadron personnel live just minutes from the air base and aircraft can be airborne in short order when emergency situations arise.

The officers and men of VU-33 currently commanded by Lt.-Cdr. Anton A. Schellinck, are justly proud of their squadron, for its record to both the fleet and the community is commendable.

The squadron has a motto which sums up its capability:

"Finis Coronat Opus", which is translated: "The End Crowns the Deed".

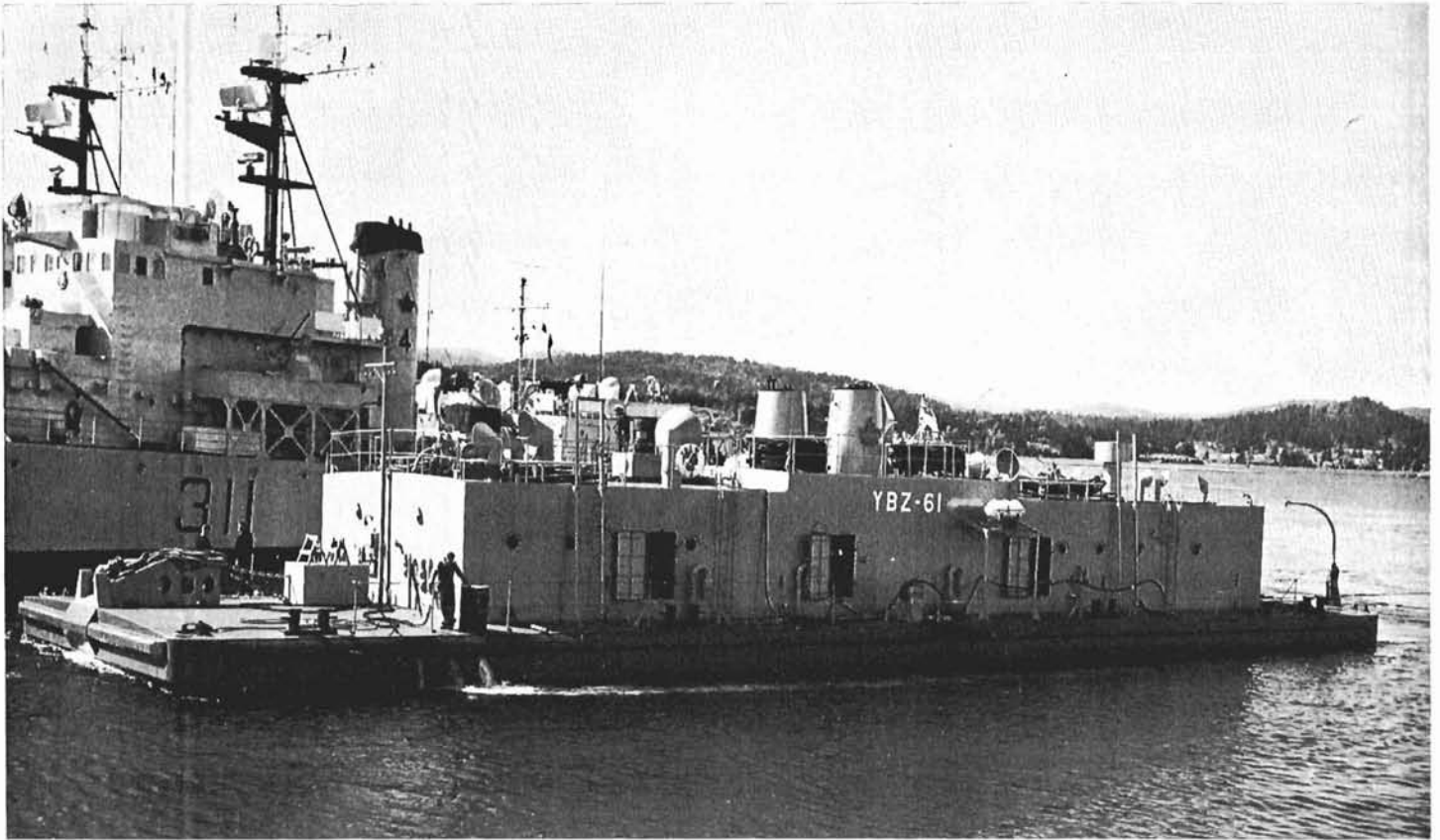

Housemaid of the RCN's Pacific fleet, the YBZ-61 is, in effect, a huge vacuum cleaner whose job is to vent, clean and gas-free the fuel tanks and bilges of warships. She not only saves time, man hours and money, but makes a messy and unpleasant job much easier to tackle. The YBZ-61 is shown at work alongside the ocean escort Stettler. (E-76131)

HOUSEMAID OF THE FLEET

THE FLEET within a fleet—the “task force” of auxiliary vessels based at HMC Dockyard, Esquimalt—has a hard working, dollar-saving young member with the somewhat unglamorous name of “Barge YBZ-61”.

She is in effect a huge vacuum cleaner and her job is to empty, clean and rid of gas the fuel tanks and bilges of the destroyer escorts and ocean escorts of the RCN's Pacific Command during refit and repair. YBZ-61 is a welcome addition to the fleet of auxiliary vessels operated by the Queen's Harbour Master, because she not only saves time and man hours, thus saving considerable money, but she makes a messy and unpleasant job a lot easier to tackle.

The YBZ-61 accomplishes her job by first steaming out bilges and tanks, then washing them down with hot sea water mixed with a detergent, and sucking out the resulting sludge. Foreign matter, such as nuts, bolts and other loose objects are sucked up along with the sludge.

The sludge is carried by armoured hose into vacuum tanks on the barge, then drained into settling tanks where the oil and water separate by gravity.



Chief engineer on board the YBZ-61 is Percy Carr, shown at work on one of the control panels in the cleansing barge. Working with Mr. Carr is a crew of four men, made up of two oilers and two firemen. (G-74890)

The water can be further cleaned by putting it through an oily water separator before discharging it overboard. The remaining oil is sampled, and in most cases, is found to be fit for use in other auxiliary craft, thus resulting in still further savings on general oil purchases.

Previously, bilge and tank cleaning was done manually by men armed with buckets and shovels, and all tank interior plates had to be wiped down by hand.

There was also the problem of disposing of the “gunk” removed from tank and bilges, but because of the YBZ-61's unique separators, this problem has been eliminated.

The YBZ-61 was built in the yards of Allied Shipyards Ltd., Vancouver, and has been in operation in the naval dockyard for about a year. There were a few teething troubles, but her crew of five men now have her working smoothly. A sister barge is at work in Halifax at the disposal of ships of the Atlantic Command.

In charge of operations on board the YBZ-61 is Len Carr, a Canadian who spent the war years in the Royal Navy. He is assisted by two oilers, Harry Dovey and Ben Williams, and by two firemen, William Rolfe and William Harding.

The job of these five men is to run the barge and her equipment. Opera-

tions inside the fuel tanks and bilges of the Pacific Command's ships are carried out by other dockyard workers.

The barge has a displacement of 700 tons. She is 120 feet in length, has a beam of 36 feet and a draught of 6 feet.

Accommodation on the barge provides for workmen, and includes two bunks, lockers for clean and dirty clothing,

table and chairs, refrigerator, hot plate and sink, and showers and wash basins.

Her equipment includes two boilers of 6,000 pounds an hour of steam each, two Diesel generators of 30 KW each, two vacuum pumps of 1,720 cubic feet a minute each, and two seawater heaters, plus associated auxiliaries and equipment.

UNDER FIVE FLAGS

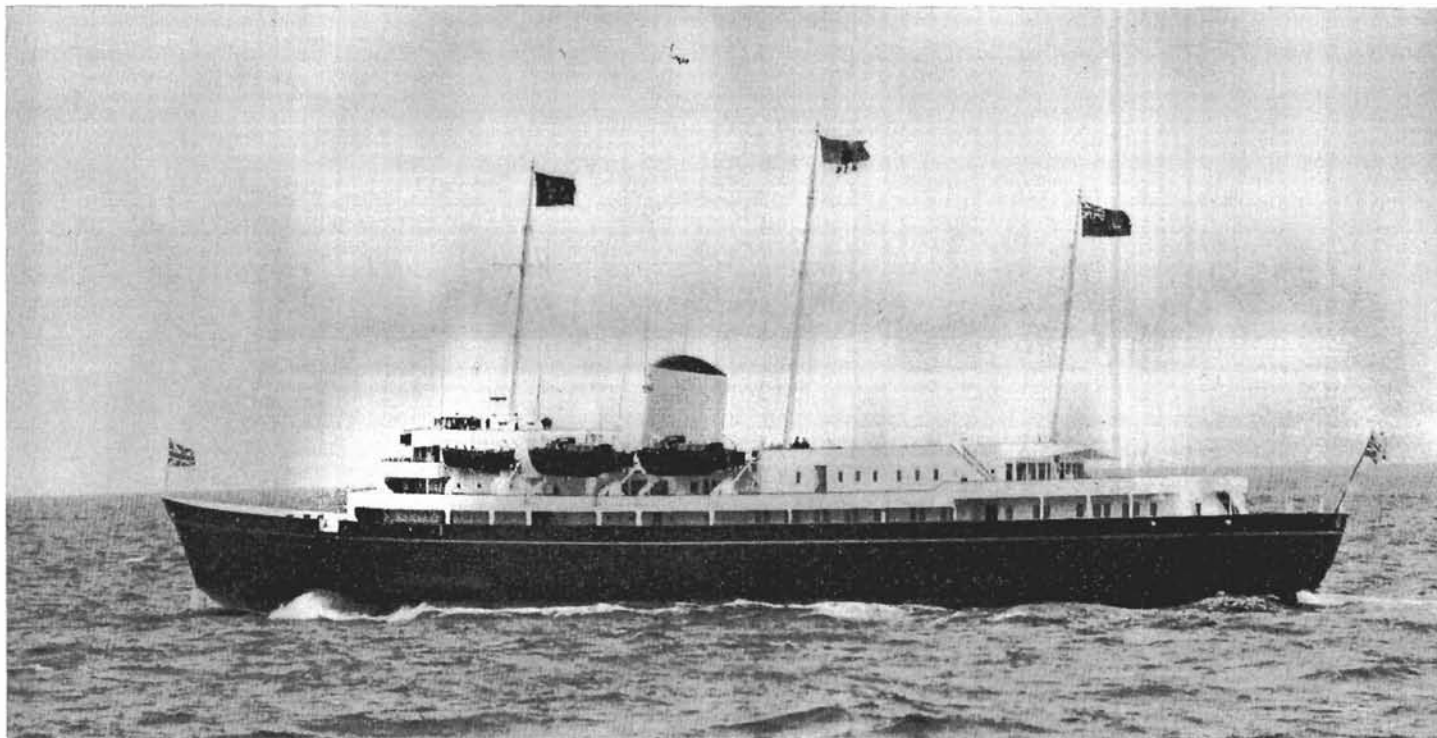

Five flags were flown by HM Yacht *Britannia* in Canadian waters: The Union Jack at the jackstaff, the Lord High Admiral's flag at the fore, the Queen's Personal Flag for use in Canada at the main, the Canadian Red Ensign at the mizzen and the White Ensign at the ensign staff.

The Queen's Personal Flag, adopted by Her Majesty in 1962 specifically for use in Canada, was flown for the first time during the Royal Visit on Government House, Ottawa, when she was in residence, as well as in HM Yacht *Britannia* when she was embarked.

The flag consists of the Arms of Canada, charged in the centre with Her Majesty's own device, on a blue field the initial letter "E" and Royal Crown, both in gold, surrounded by a chaplet of roses, also in gold.

Similar banners have since been designed for Australia, New Zealand and the Crown Colonies and probably other Commonwealth lands.

Also flown by the Queen was the lord High Admiral's flag, or Admiralty flag, worn at the foremast of the *Britannia*. This is a red flag, with a golden anchor superimposed upon it and this was the model of the Naval Board of Canada flag which was flown for the last time this year.

With the dissolution of the Board of Admiralty in London early this year, the title of Lord High Admiral was

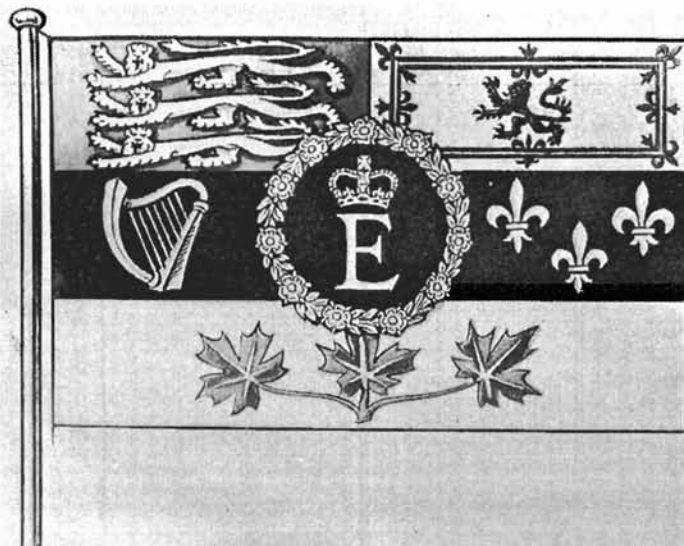

revived and assumed by Her Majesty, but the flag has been flown during previous visits of the Sovereign. (HS-76402; CN-6521)

Home from the Sea



CNA Reports Steady Growth

The steady growth and stability of the Canadian Naval Association were evidenced in the reports presented at the annual meeting in Oshawa on Oct. 3 and 4.

The directors of the CNA, by unanimous vote, enacted a bylaw authorizing an application to amend the charter of the association to change the name to the "Royal Canadian Naval Association". A special meeting was called for Nov. 22 in Windsor to ratify the bylaw, in accordance with the CNA's constitution, and to clear the way for an application for the grant of supplementary letters patent changing the name.

Commodore R. I. Hendy, RCNR (Ret), reported on the progress made in applying for inclusion of "Royal" in the association's title. It would be a privilege, he said, which should be cherished and which would entail much responsibility.

At the annual meeting, H. A. Maynard, national president, reported that six new clubs had acquired membership in the CNA during 1964, two others were awaiting membership and several other new clubs, in various stages of organization, had indicated their interest in joining the national body.

The auditor's report was submitted by N. J. Yorston, executive secretary-treasurer. On the basis of the report, it was considered the maintenance of the association's records had reached the point where consideration should be given to the appointment of a permanent, salaried secretary-treasurer. Mr. Yorston was given a sincere vote of thanks for carrying on the job so capably and efficiently.

A proposal to establish a joint publication covering the activities of the Navy League of Canada, the Naval Officers' Associations of Canada and the CNA was discussed in conjunction with S. R. Piner's report as publicity chairman. A steering committee was appointed to investigate the practicability of such a venture.

Joe Vecchiola, sports director, reported enthusiastic support for the annual sports tournament. A vote of thanks went to the director and to the Toronto Naval Veterans' Club, 1964

host, for the success of this event. The Brantford NVA will be the host club of the 1965 tournament. Golf and curling are being added to the sports program.

The main speaker at the annual meeting was Rear-Admiral C. J. Dillon, Deputy Comptroller General, who represented Air Chief Marshal Frank R. Miller, Chief of Defence Staff. He spoke of the newly amended National Defence Act and its emphasis on integration, unification and asked for the full cooperation and sympathetic understanding of everyone concerned in fulfilling the integration program.

Two directors of *Haida Inc.*, the group of Toronto businessmen who have dedicated themselves to the preservation of HMCS *Haida* as a permanent memorial to Canada's naval past, were present. Neil Bruce and Don Smith outlined the events leading to the decision to give Canada its own HMS *Victory*.

Delegates agreed an increase in the CNA's per capita tax was necessary and this will go into effect on Jan. 1, 1965.

A request from the Ottawa NVA for a change of name to the Ottawa-Hull NVA was approved and consideration will be given to a request from some clubs that they be known, for example, as "Canadian Naval Association, London Branch".

It was reported that the Peterborough NVA had acquired six acres of land for its new club house and anticipated laying the corner stone of their new building in the near future.

Distinguished guests at the annual meeting included Rear-Admiral Dillon; Commodore P. D. Taylor, Commanding Officer Naval Divisions; Commodore Hendy, honorary president of the CNA; R. G. Bundy, Vice-president of Ontario of the Naval Officers' Associations of Canada; Cdr. W. J. Floyd, naval liaison officer to the CNA, and Cdr. H. C. Tilbury, commanding officer, HMCS *Star*, the Hamilton naval division.—S.R.P.

WHOSE BADGE?

WHAT LOOKS like a cap badge almost ready-made for integration has been sent to the Naval Historian at Canadian Forces Headquarters by Colin Howard, of Hamilton, Ont., for identification. Its style suggests First World War origin.

The elements of the metal badge are a crown, wings, maple leaf and fouled



anchor. A similar badge was worn in the Canadian Air Force (before the "Royal" was added) back in the early '20s, except the letters "CAF" were superimposed on the maple leaf.

The Naval Historian has found that the badge has a certain resemblance to an officer's cap badge proposed for the Royal Canadian Naval Air Service in 1918. However, as far as can be learned, the insignia did not get past the design stage.

Anyone who knows anything about the origin or function of the badge is invited to write to the Naval Historian, Canadian Forces Headquarters, Ottawa.

Veterans Advised On Wearing Medals

Most veterans, when they appear on Remembrance Day or similar parade, wear their medals proudly, but the wearing of them is not always consistent. With their war service and attendant "dress regulations" in the limbo of history, this is not surprising.

Medals—an omnibus term which includes gallantry awards, decorations, campaigns and service awards, foreign decorations, etc.—are normally worn at Remembrance parades and services, special ceremonies honouring the reigning Sovereign, a member of the Royal Family or the head of a foreign state, regimental reunions and similar functions.

When it is appropriate to wear medals, the standard or "issue" medals are the ones to be worn, except on full

evening dress, when miniatures may be worn. Miniature medals are also worn occasionally on dinner jackets—tuxedos—but it is not correct to wear them on formal day-time dress or lounge suits in place of the regular medals.

When weather conditions necessitate the wearing of coats, medals are worn by veterans on the overcoat in the same relative position as on a jacket.

Veterans who have not yet received their Second World War medals may do so by writing to War Service Records, Department of Veterans Affairs, Ottawa 4, giving their full name, former service number and branch of the service.—*Canadian Veteran News Notes*

FAA Group Open To Canadians

Canadians are being invited to join the Fleet Air Arm Officers' Association, formed in Britain in 1957 to maintain

association between officers who were serving or had served in the Fleet Air Arm. Membership is also open to serving or former officers in any service of the Crown who had been connected with the Fleet Air Arm.

Because naval aviation was not introduced into the Royal Canadian Navy until the end of the Second World War, naval aviators from Canada for the most part served with the Fleet Air Arm as members of the RNVR or RCNR on loan.

The Fleet Air Arm Officers' Association has its headquarters at 94 Piccadilly, London W1, England, and circulates a news letter containing news of members and service information of general interest.

The association's year dates from Nov. 1 of one year to Oct. 31 of the next. The overseas membership is one pound.

STRANGE SEQUEL TO MESSAGE

LAST JUNE while the *Athabaskan* was carrying out anti-submarine exercises off the Scottish coast, a sailor, during a rare moment of relaxation during the exercises, threw a number of bottles over the side. In each was his name, address, ship's name and the date the bottle was launched. The following is a copy of the letter AB J. Boudreau received upon arrival in Halifax a few weeks later:

Dear Mr. Boudreau:

I picked up your address in a bottle on the beach of Taligo Bay, Isle of Islay, Scotland, while on holiday. You must have been close to land as I found it two days after you "launched" it. However I thought I would let you know. The name "*Athabaskan*" interests me greatly because during the last war I was a POW in Germany, as I am ex-merchant navy.

I was with some of the crew of the other *Athabaskan* which was sunk

April 29, 1944, off Brest. The reason I know the date so well is that I kept a small log book in the camp and in it is a drawing of a radio officer half submerged and the Captain standing in the doorway of the radio cabin saying, "Signal to Admiralty from *Athabaskan*—Enemy Torpedo destroyed by ramming." It is drawn by Hector A. Cooper, SY CPO, RCN. I have his address also. It is as he wrote it:

Hector Cooper,
SY, CPO, RCN,
Head of Jeddore,
Halifax County, Canada (God's
Country).

No doubt, like me, he finished with the sea, but should you know of him (perhaps the newspapers would help), I send him my best wishes.

May I send you also my best wishes and good luck. Perhaps some day you will visit England. Should you be in Liverpool I would be pleased to see you.

I was in Halifax dry-dock the first winter of the war for two or three months. I quite enjoyed myself there, where the people were so kind to us sailors and gave us a fine Christmas.

They were great days; although there was war. One found much more friendship about than you do these days. I was nearly five years a prisoner and was glad to see home. I work for a large Telephone and Electronics Company in accounts. I am married but have no family.

It is a much quieter life than the old days. Perhaps I shall hear from you some day. Should you care to write, I will be most pleased to hear from you and yours.

Yours sincerely,

URBAN PETERS

33 Rudson Road,
Childwall,
Liverpool 16, England.



AFLOAT AND ASHORE

ATLANTIC COMMAND

VS 880

A detachment of six Tracker aircraft from VS-880, HMCS *Shearwater's* anti-submarine squadron, returned in early December from a week-long tour on board the USS *Essex*, USN aircraft carrier based in Quonset Point, Rhode Island.

The return of the detachment completed the program arranged between Canadian and U.S. naval authorities earlier this year, allowing VS-880's pilots to maintain their proficiency in carrier flying while the *Bonaventure* was in drydock in Saint John, N.B.

In all, four such groups went south to operate from three USN carriers during the late summer and fall.

The first detachment to leave was under the command of Cdr. R. C. MacLean, commanding officer of VS-880. The RCN trackers operated from the Boston-based carrier USS *Wasp* from July 20 to August 2.

Between August 14 and 24 a second detachment worked from the deck of the *Essex*, and during the first week of October a third detachment joined USS *Intrepid* in Norfolk, Virginia.

In all, 33 days were spent by Canadian ASW pilots from VS-880 on board U.S. carriers. During this time 596.8 hours were flown from the USN decks and a total of 206 deck landings were



Ord. Wren Dianne Young, of HMCS *Tecumseh*, Calgary naval division, has been awarded the trophy for the best new entry wren under training at HMCS *Naden* during the past summer training period. Wren Young joined the RCNR in October 1963. The silver tray was presented to her by Commodore P. D. Taylor, Commanding Officer Naval Divisions. (TH-0256)

recorded by the Canadian operational pilots of the squadron.

With the return of the last detachment and the resumption of operations by the carrier *Bonaventure*, the pilots of VS-880 can once again operate from the familiar deck of their own carrier.

Cdr. MacLean said that the operation of the Canadian Trackers from the U.S. carriers was a complete success and that the training would stand them in good stead when they returned to the *Bonaventure*.

The hours of flying they chalked up on the American carriers has proved that the ASW pilots of VS-880 can operate from other carriers and can be integrated into an unfamiliar flying program without difficulty.

NAVAL DIVISIONS

HMCS *Tecumseh*

Calgary's HMCS *Tecumseh* was presented in mid-October with the trophy

for the most efficient naval division in Canada during the 1963-64 training year at an inspection by Commodore P. D. Taylor, Commanding Officer Naval Divisions.

Commodore Taylor inspected the *Tecumseh* facilities in the afternoon and made the presentation at a parade in the evening.

The naval division also was judged the best in Canada in the 1962-63 training year.

The Naval Division Efficiency trophy, a silver model of a St. Laurent class ship, was presented for annual competition in 1951 by the Canadian Shipbuilding and Repairing Association.

Canadian Forces Decorations, signifying 12 years' service in the armed forces, were presented to seven persons.

They included Lt.-Cdr. D. G. McGregor, Lt. W. J. Arkell, CPO L. R. Cool, CPO Victor Dovey, Wren CPO S. G. Ferguson and PO Robert Hutchings.

Ord. Sea. Herman Ursel, received a



An ambition of long standing was fulfilled when Rev. Charles J. Mersereau was sworn into the RCN by Lt. N. B. Pakenham at the RCN Recruiting Centre in Saint John as a chaplain (RC). (Photo by Don J. McIntyre)

silver bos'n's call for being the best in his class in summer training at Great Lakes Training Centre, Hamilton.

Ord. Wren Dianne Young received a silver tray as the best new wren in summer training at HMCS *Naden*.

PACIFIC COMMAND

HMCS *Margaree*

Bonds with the community were strengthened when HMCS *Margaree* distributed a total of \$3,825 to 12 widely varied charitable and community agencies in the Victoria area last September. The money is from destroyer escort's ship's fund and was allocated by members of the *Margaree's* welfare committee. The *Margaree* on September 14 went to a local shipyard and was paid off September 25 to undergo major conversion.

The donations brought to \$4,657.50 the amount that the *Margaree* had given to helpful organizations since the beginning of the year.

Recipients of the most recent cheques were: Greater Victoria Community Chest, \$1,500; Salvation Army \$375; Queen Alexandra Solarium, \$150; Goodwill Enterprises, \$100; Protestant Orphanage, \$100; CARE, \$150; and \$50 to an 11-year-old girl in Hong Kong whom HMCS *Margaree* "adopted" several years ago. The ship's company has sent money each month towards the child's education, clothing and food.

To the RCN Benevolent Fund went a cheque for \$1,000. The organization provides financial assistance to naval personnel and their families. An example of the fund's work was seen last spring when a sailor from HMCS *St. Laurent* died while in Singapore. The Benevolent Fund immediately offered to pay his widow's plane fare to and from the funeral in Singapore.

To the Armed Forces Centre, located in downtown Victoria, went \$250 to assist the centre in its work and facilities to provide a "home away from home" for personnel of the three services.

Cheques for \$50 each also went to the Maritime Museum of British Columbia, the Pacific Command Sports Fund, and the Command's Well Baby Clinic.



LAKE-BOTTOM FIND



Two RCNR divers, Lt. R. K. Leishman and Lt. Ian MacDonald, now retired, discuss the recovery of an anchor which had lain on the bottom of Lake Ontario for 92 years and was brought to the surface by divers from HMCS *Cataraqui*, the Kingston naval division. (Photo by Jack French)

CLEARANCE DIVERS from HMCS *Cataraqui*, the Kingston naval division, during the past summer recovered from the bottom of Lake Ontario an anchor that had lain on the lake bottom for nearly a century. The 1,200-pound hook was almost as good as new.

The six-foot anchor belonged to the American schooner *Medbury* which was sunk in a collision near Simcoe Island 92 years ago. The ancient misfortune was one that has given *Cataraqui* divers plenty of opportunity to exercise their skills—a voluntary chore that reached fulfilment when a tow truck at last inched the anchor up onto the dock at Kingston naval division's headquarters.

The recovery of the anchor followed an entire summer of diving operations at the site of the wreck. Members of the HMCS *Cataraqui* Diving Club spent most of their spare time sifting through the wreckage and trying to pry the anchor from the schooner's hull.

Once the anchor was freed, four 45-gallon drums were used to float it from Four Mile Point to Kingston.

Two *Cataraqui* divers, Ldg. Sea. Ted Cartledge and Ldg. Sea. John Slack, found the schooner in 1961. They followed up reports of fishermen who had reported catching nets on the wreckage.

The two spent one whole week searching the Four Mile Point area before finding the *Medbury* in about 22 feet of water.

A report of the collision appeared in the *Kingston News* of Nov. 6, 1872:

"Last night about 10.30 o'clock a collision occurred off Four Mile Point between the schooners *Hercules* and *Medbury*, by which the former lost her stern and the latter was stove in and sunk. Yesterday afternoon the *Hercules* sailed for Hamilton with railroad iron. Finding the weather unfavourable for satisfactory headway, she had 'come about' and was returning to this port when she sighted the *Medbury*, salt laden for Chicago.

"Both displayed lights but the masters of neither had the least conception they were so near until the vessels struck violently, and the extent of the damage incurred was at once apparent. The *Hercules* is insured here and the *Medbury* in Cleveland."

Douglas Fluhrer, Kingston parks superintendent, has indicated he would like to obtain the anchor for one of the parks. The *Cataraqui* diving club members have considered selling the anchor to a museum but most favoured an outright gift to the city.

SCIENCE AND THE NAVY

Gills for Divers A Possibility

Will skindivers some day be equipped with artificial gills that enable them to extract oxygen from seawater and thus remain under water indefinitely?

The question is not quite as absurd as it might have appeared before the recent announcement of the development of a new synthetic membrane, capable of extracting oxygen from ordinary air or seawater.

The *Scientific American*, in reporting the new material, says that it may provide the basis for a host of applications, such as providing an oxygen supply for the crew of a submarine or an underwater experiment station. Because the membrane allows a small amount of water to pass through but holds back salts, fresh water for drinking would be a bonus.

The membrane, says the *Scientific American*, was developed by Walter L. Robb of the General Electric Research Laboratory and is made of silicone rubber, about a thousandth of an inch thick.

"Although it is completely free of holes, it permits the passage of certain liquids and gases more easily than others. The molecules of these substances actually go into solution with the material of the membrane on one side and emerge from solution on the other side.

"Oxygen, which ordinarily constitutes about 20 per cent of the atmosphere, passes through the new membrane more than twice as fast as nitrogen, which is four times as plentiful. Thus, if ordinary air is brought into contact with one side of the membrane while the other side is maintained at a lower pressure, the air passing through the membrane will be rich in oxygen.

"For example, if the low-pressure side of the membrane is maintained at a 15th of atmospheric pressure, the air passing through the membrane will contain about 35 per cent oxygen. Since patients in hospital oxygen tents normally require enriched air containing about 35 per cent oxygen, a few square yards of the new membrane, together with a pump to remove the enriched air from the low-pressure side, could eliminate the need for costly and cumbersome oxygen cylinders."

"Another potential application of the new membrane," the article continues, "takes advantage of the fact that seawater is saturated with air to a depth of several hundred feet. A membrane with seawater flowing across one side and with the pressure below one atmosphere on the other side would extract oxygen and nitrogen from the water and resist the passage of the water, even under very high pressure. Carbon dioxide and other gases would conveniently pass through the membrane in the opposite direction and be released into the water. Thus the membrane could perform the same functions as the gill of a fish."

New Submarine Escape Method

Live escape trials by a new technique from depths of up to 200 feet have been carried out from the submarine *Orpheus* in Loch Fyne.

A feature of the trials—carried out by six of the escape training staff from HMS *Dolphin*, Gosport—was to dress the escaper in a suit incorporating a cotton fabric hood with a plastic facepiece to cover his head and shoulders and then release him from a one-man cylinder, flooded from the sea, inside the submarine.

The cylinder's outside escape hatch was opened from inside the submarine once the pressure inside the cylinder was equal to that of the surrounding sea, no action being required on the part of the escaper.

A result of this escape method is that pressurization, essential for escaping from depth, is achieved rapidly and the man concerned is subjected to it for the absolute minimum period before leaving the submarine. Inside the flooded cylinder, he breathes air supplied through an air pipe from the submarine, while he uses the air trapped in his hood on his way to the surface.

In preparation for these live trials, personnel took part in a series of tests at depths of 500 feet in simulated conditions in decompression chambers at the RN Physiological Laboratory at Alverstoke. After remaining at this "depth" for 20 seconds, men were decompressed to the "surface" at five feet per second.

These trials suggest that much greater depths than the 266 feet, achieved in the Mediterranean in 1962 using normal British buoyant techniques, can be safely achieved.

In charge of the trials in Loch Fyne was Lt.-Cdr. L. D. Hamlyn, RN Submarine Command Escape Officer.—*Naval News Summary*

SEA-AIR SURVEY

The Canadian Survey Ship *Baffin*, attached to the Bedford Institute of Oceanography, departed Nov. 16 for a month-long survey of the waters between Georges Banks and Cape May, New Jersey.

The *Baffin* joined the United States Naval Oceanographic ship *Gillis* and two aircraft, one from the RCAF's 415 Maritime Patrol Squadron, Summerside, P.E.I., and a U.S. Naval Oceanographic aircraft.

The survey was co-ordinated by the Marines Sciences Department of the U.S. Naval Oceanographic Office and the Canadian Maritime Commander Atlantics' Oceanographic Services for Defence.

Three types of information flow into oceanographic centres now, from mer-

chant ship reports, warship reports using bathythermographs (underwater thermometers) and aircraft reports using radiation thermometers. This survey was to determine what degree of compatibility there is between the three methods, thus finding whether portions of each may be used separately in preparing synoptic charts (forecasts).

The survey is expected to provide information on which forecasters will base the synoptic charts they draw up daily on ocean and sub-ocean water temperature.

Following the return of CSS *Baffin* to Halifax on Dec. 16, all information gathered by her is being compiled and will be exchanged for information acquired by USNS *Gillis*, with a view to improving the existing underwater thermal forecasting information.

Dr. Ford Heads Bedford Institute

Dr. William L. Ford, well-known Canadian marine scientist and administrator, has been appointed director of the Bedford Institute of Oceanography at Dartmouth, N.S. He is a former Director of Scientific Services for the Royal Canadian Navy.

The Institute is Canada's East Coast centre for hydrography, oceanography, geophysics, chemistry and geology in Atlantic and sub-Arctic waters and, in addition, deep-ocean studies. It can accommodate 300 professional and supporting staff. It also houses the Atlantic Oceanographic Group of Fisheries Research Board.

A former scientific adviser to the Chief of the Naval Staff and now chief of personnel at Defence Research Board and member of the defence research management committee, Dr. Ford will assume his new post with the Department of Mines and Technical Surveys about April 1, 1965.

He succeeds Dr. W. N. English, who recently accepted a position as superintendent of the electronics wing in the Canadian Armament Research and Development Establishment at Val Cartier, Quebec.

Dr. Ford has done many years of at-sea research in both the Atlantic and Pacific oceans, and has extensive experience as a director of marine research programs and adviser on naval research matters.

Following a four-year period in the nylon research laboratory of the Du Pont company in Wilmington, Delaware, Dr. Ford turned his attention to oceanographic research in 1944.

Until 1948 Dr. Ford was an oceanographer with the Woods Hole Oceanographic Institution at Woods Hole, Mass., carrying out projects in various areas of the Atlantic and Pacific oceans. During the atomic experiments at Bikini in 1946 he was a member of the oceanographic team concerned with the drift of radioactive waters at the Bikini site.

In 1948 Dr. Ford joined the Naval Research Establishment of the Defence Research Board in Halifax. During 1952-53, he attended the National Defence College in Kingston, and then assumed the position of director of scientific services for the Royal Canadian Navy.

Dr. Ford was superintendent of the Pacific Naval Laboratory at Esquimalt from 1955 to 1959 and, in August of the latter year, returned to Ottawa to assume the position of scientific adviser to the Chief of Naval Staff. In Novem-

ber 1963 he was appointed chief of personnel for DRB.

Raised in Vancouver and Victoria, Dr. Ford attended Victoria College and the University of British Columbia, where he obtained his BA in 1936 and MA in physical chemistry the following year. He continued his post-graduate studies in the same field at Northwestern University in Illinois and obtained his PhD in 1940.

Dr. Ford is married and has two children.

Aerosol Dispenser Danger Stressed

Bomb disposal, like charity, begins at home.

Some observations on the soundness of this revision of an old saying appear in *All Hands*, published by the USN's Bureau of Naval Personnel.

"Check That Bomb in Your Locker" is the heading of an *All Hands* article that deals with an often unsuspected danger. The article reads as follows:

Is there a bomb in your home? Or in your sleeping quarters aboard ship? There is if you have an aerosol dispenser of any type, and there are many types—dispensers for shaving cream, insect repellent, hair spray, tooth paste, deodorant, paint, varnish, polish, wax, air freshener, de-icer, ether car starter and whipped cream, to name several. These dispensers are handy, but they can be dangerous also if you don't know how to handle and dispose of them.

Gas is sealed in them under pressure. Extreme heat may build up the pressure until the can explodes like a bomb. Some injuries and deaths have been caused when people tossed supposedly empty containers in the incinerator or placed a "bomb" in hot water. It's as simple as that.

Here's a sample. One unwary individual tossed an empty aerosol can into a fire to dispose of it. As he turned his back, there was a dull thud, and a piece of ragged metal struck him in the neck, severing the jugular vein. He was dead 15 minutes later.

Another person heated a "near empty" can in hot water to "pep it up", and get out the last of its contents. Then he shook the can. Results: one lost eye, one broken jaw.



Any aerosol dispenser should always be kept away from sources of direct heat. Don't rest it on a radiator. Don't store it near a stove or a hot pipe. When the product is finished, the recommended way to dispose of the bomb is to bleed remaining gas from the container by holding down the button (do this in a ventilated area).

If you have to be really cautious, the recommendations are to wrap the container in newspaper and store (if possible) under refrigeration. This lowers any remaining pressure. Next day, the with container still wrapped, turn the bottom end away from you and puncture it. Small cans can be punctured with a beer can opener.

Then the bomb can be safely disposed of. Remember, an unpunctured aerosol container, dropped over the stern, will remain afloat for an indefinite period, possibly leaving a telltale trail behind.

Scientists on Maritime Staffs

Russell E. Banks and Dr. Carmen L. Piggott, scientists of the Defence Research Board's Naval Research Establishment, Dartmouth, N.S., have been appointed scientific consultants to the Maritime Command Atlantic, it was announced on Dec. 10. Both are specialists in anti-submarine warfare research.

Mr. Banks, a native of Bear River, N.S., has been appointed to the staff of the Flag Officer Atlantic Coast. He served with the RCAF, 1941-45, then resumed his education, graduating from Dalhousie University with BSc and MSc degrees in physics. He completed an additional year of study in oceanography at the University of British Columbia. Since joining the Naval Research Establishment in 1951 he has conducted research in physical oceanography in relation to anti-submarine warfare.

Dr. Piggott, born in Bridgetown, N.S., has been appointed to the staff of the Air Officer Commanding, Maritime Air Command. He received his BSc and MSc in physics at Dalhousie University and PhD at McGill University. During the past 10 years he has been engaged in research at NRE on underwater acoustics and anti-submarine warfare.

The appointment of DRB scientific consultants to Maritime Command Atlantic will further strengthen the cooperative efforts of the Navy, Air Force and Defence Research Board to maintain and improve Canada's anti-submarine warfare capability. The RCN and RCAF both maintain liaison officers at NRE. Those at present serving are Cdr. R. A. Beach and F/L J. R. Marshall.

HERE AND THERE IN THE RCN



Retirement has brought to an end 17 years' service at the Canadian Services College, Royal Roads, for Miss Patricia L'Amie. Here, Miss L'Amie receives her certificate of service from Royal Roads commandant, Captain W. P. Hayes. Miss L'Amie spent the greater part of her time at Royal Roads as secretary to the succession of commandants serving there. Born in Scotland, Miss L'Amie was in government service in Britain, United States, Mexico and, finally, the Canadian Civil Service. (RR-2590)



The 20,000th accident-free simulated deck landing was made at the Naval Air Facility, Debert, N.S., on Nov. 23 when Lt. Bob Edey set a CS2F Tracker down. A parade of naval firefighters, with fire axes at the slope, was promptly organized and Lt. Edey and co-pilot Lt. Charles Poirier were presented with badges to commemorate the occasion by Lt.-Cdr. H. R. Welsh, officer-in-charge. CPO G. J. Roemer, in charge of operations at the field, is looking over Lt.-Cdr. Welsh's shoulder. Fire Chief J. Saxton, is at the far left. The airfield was re-activated in September 1961 for pilots to practise deck landings using the mirror landing system. (DNS-34587)



Training activities at the Canadian Services College, Royal Roads, were discussed in late November by Dr. H. D. Roberts, St. John's Nfld., national president of the Navy League of Canada, who was in British Columbia inspecting the Royal Canadian Sea Cadet Corps. Dr. Roberts, right, is shown with Royal Roads commandant, Captain W. P. Hayes. (RR-3605)



The warship's last captain, Cdr. J. M. Cutts, presents the ensign from the Tribal class destroyer Miacac to Chaplain Earl Sigston, Chaplain of the Fleet (P), at a brief ceremony at St. Augustin's Church in Jollimore, near Halifax. The White Ensign was then placed in the hands of Rev. T. R. B. Anderson, pastor of the church. (HS-76709)

FACING UP TO THE ASW PROBLEM

ONE NEWSPAPER met the problem of surveying the fine, new 1965 edition of the United States Naval Institute's *Naval Review* by assigning each of the 12 essays to a separate member of the staff. This is probably the only method by which justice can be done to the wealth of thought and fact enclosed within the handsome covers of this book.

No effort will be made here to give the *Naval Review* the comprehensive discussion it deserves. There isn't the space for it. However, mention can be made of certain features that will have immediate appeal to RCN readers.

With this approach in mind, one is immediately confronted by the subject matter of the first essay in the volume: "Anti-submarine Warfare—Where Do We Stand?" The author is Vice-Admiral C. E. Weakley, USN, Commander Anti-submarine Warfare Force, Atlantic Fleet, the officer who would be responsible for the protection of U.S. shipping in the Atlantic in the event of war.

Admiral Weakley points out that in the First World War a small force of German submarines, never more than 200 boats, came close to crippling the British Empire.

And, in the Second World War, "the Germans had only 40,000 men afloat in submarines. In July 1943, the Atlantic Allies had some 950 ocean escorts and 2,200 aircraft fighting 430 German ocean-going submarines. Only then did it become apparent that, barring any unforeseen significant change, winning the 'Battle of the Atlantic' was a question of time."

He finds that today the quality of anti-submarine warfare units in relation to the threat is superior to that in any previous peace-time period, but the submarine is ahead in that it takes such a large number of anti-submarine units to deal with a small submarine force.

The essay draws attention to the merits and failings of the various anti-submarine weapons. Aircraft have the advantage in speed of search attack and in freedom from counter-attack. However, they have limited staying power and payload and the fact that they have to use sonobuoys to search beneath the surface pins them down to a restricted area. The helicopter, with less speed and endurance than fixed-wing aircraft, has greater detection capability.

The surface ship lacks the ability to hide. She can be detected visually, by radar or by sonar. However, she has staying power, can carry out repeated

attacks and has considerable self-repair capability. Furthermore, she can be operated successfully with a smaller proportion of technical personnel than aircraft or submarine.

The submarine's advantages (and Admiral Weakley appears to be confining

BOOKS for the SAILOR

his observations to the modern, fast nuclear submarine) lie in her power of concealment and her capability of high, sustained speed. But she has limited power to effect repairs while submerged and minor damage may force her to expose herself fatally. The submarine is almost blind and requires highly trained, expensive personnel.

Admiral Weakley hesitates to say whether the convoy system will be used in a future war. This will be dictated by circumstances, he says, but "we should be prepared to use convoy on short notice." He points out that the convoy is not merely a defensive mechanism. It is also a method of forcing submarines to come within range of anti-submarine units.

He is a drone-helicopter advocate and stresses the advantages of this device as an all-weather weapon.

"The British and Canadians," he observes, "have gone to the manned helicopter to be used from small ASW ships, perhaps because such aircraft were already in hand and perhaps because, in spite of higher unit cost and safety problems, the manned helicopter has more capability than the helicopter without a man."

He discusses the new weapons—the high-speed torpedoes and the anti-submarine rocket, ASROC—which do much to counteract the speed advantage of the new, fast, deep-diving submarines. He compares the wonder-weapon ASROC with "hedgehog", a weapon long since succeeded in the RCN and RN by the more sophisticated squid and limbo. A little puzzling is his reference to the hedgehog as being incapable of being trained, something that was not true of the RCN's Second World War version of the weapon, which could be trained over quite a wide angle. War-time gossip had it that this was a Canadian improvement on the original weapon.

However, this is a small matter and Admiral Weakley's concluding words are worth repeating:

"Like the Red Queen, we must exert major effort to stay where we are; to keep control of the advancing capability of the 'mix' of submarines which might be placed against us. Time is on the side of the anti-submarine effort, but only if we use it wisely and effectively."

UNDERSEA WARRIORS

BURIED AMID the lurid murder and romance novels of the paperback stands are war stories, mostly of the "Go Marines, Go" variety. Now and then there is a paperback that should be read by the professional naval type.

Such a one is *They Fought Under the Sea*, by the editors of that worthy newspaper, *Navy Times*.

The co-authors trace the history of submarines, and a lot of it was Ameri-

can, it seems, and give a batch of episodes through the years of war and peace. They took the trouble to add a stop-press Chapter 15 on the *Thresher* tragedy, which lies cheek and jowl with an appendix of the log of the *Squalus*, which suffered loss of life in 1939 within sight of the New Hampshire coast, in 240 feet of water. Thanks to the first use of a diving rescue chamber, 33 persons were saved, another 26 having perished in the flooded compartments.

There is also a bit about the mysterious disappearance of the Free-French-manned, super-submarine *Surcouf* in the last war. All in all, good reading for half a dollar—H.C.W.

THEY FOUGHT UNDER THE SEA, by the Editors of *Navy Times*; published in paperback form by Monarch Books, Inc., Derby, Conn.; 189 pages; price \$.50.



Canadians will be interested in Captain W. D. Brinckloe's essay on "The Future of the Surface Fighting Ships". This deals, in part, with runaway costs of surface ships, culminating in the *Bainbridge*, with a price tag of \$160 million.

He calls attention to the destroyer's loss of speed advantage over submarine, the latest of which are said to be capable of speeds of 30 to 50 knots submerged. There are three ways of regaining this advantage:

- Put the speed into the weapons;
- "Crank more power into the same old hull";
- Strip the hull down to what can be driven at the required speed by a reasonable power plant.

He says that to beef up a 35-knot destroyer to 40 knots would require almost a 50 per cent increase in power for a one-seventh gain in speed, at a cost of \$1 million a knot.

Captain Brinckloe goes into the engineering problems of the hydrofoil arising from the balancing of speed requirements against payloads and costs.

He urges a highly critical look at the ASW requirements and, to reduce payload, "accept nothing that can possibly be omitted.

"We might start by taking a look at what English designers have shoe-horned into the 177-foot, 600-ton corvettes being built for Ghana; sonar, air and surface radar, stabilizing fins, a squid anti-submarine launcher, a 4-inch and a 40-mm gun—even air conditioning."

He takes a pretty austere view of the ship of the future, a view that may seem almost fanciful to some members of the Age of Affluence. His conclusion:

"Our future high-speed ships, with menial tasks taken over by robots or postponed until return to base, with a highly trained few manning the essential controls, need waste no space on recreational rooms any more than bombers do. If professional demands present a high challenge, if the crews are an elite corps doing vital tasks in a vital ship, then, even if space limitations make them crawl on all fours from bunk to control station, there will be habitability enough."

The foregoing is a sampling from the first two essays, perhaps enough to convince the reader that the *Naval Review* is no compendium of ancient saws or pious platitudes, but a book that comes to grips with some serious problems and will provide considerable material for argument.

The interest is sustained in the subsequent chapters: "Naval Weapons Today", "Aircraft Carrier Design", "Systems Analysis and the Navy". "The French Navy," "Alaska and Siberia: A Strategic Analysis", "The Soviet Air Forces"; "Marine Corps Aviation Today", "The Military Support Role of MSTs", "Naval Medicine and Modern Sea Power", and "Search and Rescue in the '60s".

Additional features are a naval chronology, a collection of the best naval photographs of 1963, a section of research craft and auxiliaries and an outline of the U.S. defence program for 1965-69.—H.M.C.

NAVAL REVIEW 1965, edited by Frank Uhlig; published by United States Naval Institute, Annapolis, Maryland; 417 pages, illustrated, \$12.50.

Dear Sir:

. . . I would like to add something to Naval Lore Corner No. 131 in the October 1964 *Crowsnest*.

In 1933 the Estonian destroyers *Len-nuk* (ex-Russian *Avtroil*) and *Vambola* (ex-Russian *Spartak*, ex-*Mikula Mak-lei*) were sold to Peru and renamed *Almirante Guise* and *Almirant Villar* respectively.

Thus they served in the Imperial Russian Navy, in the Bolshevik forces, in the Estonian Navy and in the Peruvian Navy.

Yours truly,

J. DUERKOP

Hearne House,
University of Saskatchewan,
Saskatoon.

Dear Sir:

No piece of historical research is ever really finished and the article "A Letter from the Queen", which was written in this office, illustrates this fact.

Towards the bottom of the left hand column of page 16 in the October *Crowsnest*, in a paragraph on the abolition of the half pay system in the Royal Navy, is a statement that it was never used in the RCN. Recently regulations governing it have turned up and they show that it was in force from 1920 to 1944.

LETTERS

In 1920, the RCN was facing the situation that the British service had faced after previous wars: it could not find appointments for all of its officers but did not want to lose them, so the pay scales put into force on July 1, 1920, included provisions for half pay.

Apparently the Canadian service did not see fit to follow the example of the RN in 1938 when half pay was abolished in Britain, for the articles governing it remained in *Canadian Naval Regulations* until they were superseded by the first issue of KRCN under the *Naval Service Act* of 1944.

Although the regulations remained on the books throughout most of the war, it seems unlikely that anyone was put on half pay after 1939, except as a punishment.

Yours truly,

E. C. RUSSELL
Naval Historian

Canadian Forces Headquarters,
Ottawa.

VETERAN RECALLS FALKLAND BATTLE

Fifty years after the Battle of the Falkland Islands on Dec. 8, 1914, W. S. Woods, 2924 Qu'Appelle St., Victoria, has written to *The Crowsnest*, recalling

the ships and events of that time. He was serving in HMS *Cornwall* in the battle that brought about the destruction of Von Spee's East Asiatic Squadron and revenged the British defeat at Coronel.

"When you get this letter it will be the 50th anniversary of the Battle of the Falkland Islands," Mr. Woods predicted—and the letter reached the magazine on the exact day. "I am over 70 years of age now, but I remember it well."

Recently he saw the name of an old messmate in an English newspaper. His friend of First World War days is nearly 80 years of age now, ailing and blind. However, his wife replied to a letter from Mr. Woods that his old shipmate remembered him well after all that time.

A letter from Mr. Woods in the November 1959 issue of *The Crowsnest* described his life in HMS *Cornwall* and mentioned his service in the Canadian submarine *CH-15*.

SHIP PAPER SOUGHT

H. R. Keene, 376 Chantilly Place, Beaconsfield, Que., is interested in obtaining a copy of any or all editions of a shipboard weekly, *The Haida Headliner*, published in HMCS *Haida* when he was serving in the ship in the Far East from July 1952 to August 1953.

THE NAVY PLAYS

Shearwater Tops Maritime Rugger

Shearwater, in recent years the spear-head of rugger revival Down East in the Navy, defeated the Halifax Rugby Club 17-9 on Oct. 18 to win the Maritime open championship. They shut Greenwood out 31-0 for the armed forces Maritime title and a chance to meet the Haligonians in a week-end of play, during which they won all games played.

This put the naval airmen (they call themselves the Falcons after the DoT falcons imported recently to chase seagulls off the runways) against the Montreal Wanderers at the end of the month for an unsuccessful tussle for eastern Canada supremacy and the MacTier Trophy. They lost 16-3.

The Eastern Canadian Rugby trophy was presented for play in 1912 by the president of the CPR and for the next 40 years teams competed for it, except in the war period. The cup game came to Halifax this fall after an absence of 20 years.



Lt.-Cdr. Peter Vivian Reader, RCN, chats with two of the U.S. Naval Academy's outstanding scholar-athletes, Roger Staubach (right) and Myron Hura, during a recent trip to the Naval Academy, Annapolis, Maryland. Lt.-Cdr. Rader, who is assigned to the international staff of the Supreme Allied Commander Atlantic at Norfolk, Virginia, is a member of a briefing team which appeared at the Naval Academy, on Oct. 16 to tell students NATO's story. Midshipman Staubach has been one of the United States' foremost collegiate football players for the past three years. Quarterback of the Navy football team, he was awarded the Heisman Trophy in 1963. The Heisman Trophy is presented annually to the college football player voted outstanding in the United States. Midshipman Hura is Navy's star soccer player. He led the team's scoring in 1963, and was named to the All-America soccer team the same year. (Official U.S. Navy Photograph)

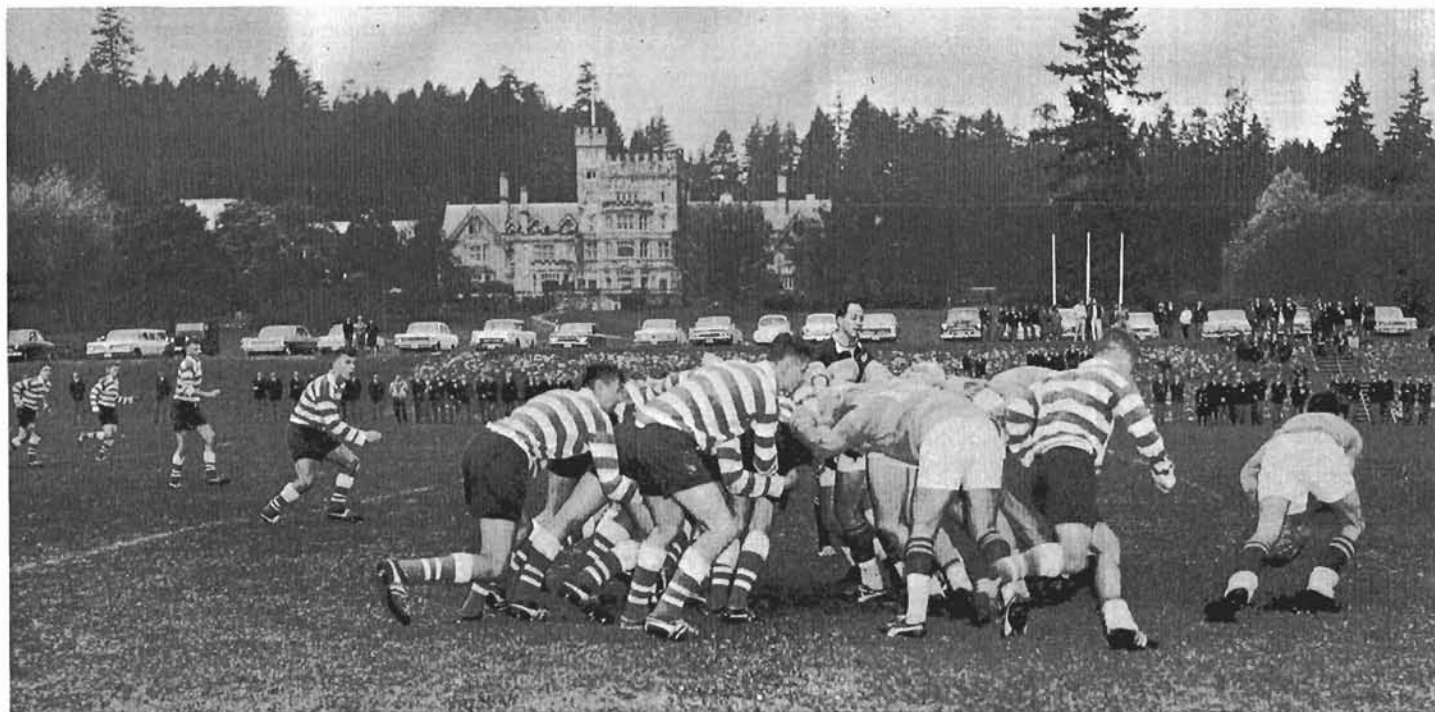

A score of 8-0 against the University of Washington gave the Canadian Services College, Royal Roads, the first game in a home-and-home rugby series with the U.S. university. Here the match is well under way on the services college field on Oct. 31. The Royal Roads cadets will meet the U of W team next in Seattle on Feb. 4. (RR-3542)

RETIREMENTS

CPO CHARLES ALEXANDER BRODIE, CD and 1st Clasp; C2WV4; joined RCNVR June 15, 1940; served in the RCN Feb. 28, 1944, to Aug. 11, 1961; rejoined RCN Nov. 14, 1961; served in Toronto naval division, *Stadacona*, *Fundy*, *Venture*, NOIC Toronto, *Chaleur II*, *Swift Current*, ML-053, ML-072, *Niobe*, *Vernon*, *Humberstone*, *Cornwallis*, *St. Pierre*, *Peregrine*, *Llewellyn*, *Micmac*, *Iroquois*, *Swansea*, *Nootka*, *La Hullose*, *Bytown*, *Portage*, *Naden*, *Magnificent*, *Swansea*, *Prestonian*, *Algonquin*, *Scotian*, *Nootka*; retired Nov. 13, 1964.

CPO RUSSELL ROBERTSON COX, CD; C2ER4; joined RCNVR Nov. 4, 1939; transferred to RCN June 6, 1940; served in *Stadacona*, *HMS Emerald*, *HMS Dominion*, *Niobe*, *Saguenay*, *Shelburne*, *Kentville*, *Peregrine*, *Stettler*, *New Liskeard*, *Scotian*, *Middlesex*, *Sans Peur*, *Nootka*, *La Hullose*, *Micmac*, *Iroquois*, *Sussexvale*, *Wallaceburg*, *Sioux*; retired Nov. 2, 1964.

CPO THOMAS DAY, CD; C2ER4; joined RCNVR Jan. 20, 1944; transferred to RCN April 9, 1945; served in *Discovery*, *York*, *Stadacona*, *Cornwallis*, *Scotian*, *Uganda*, *Naden*, *Athabaskan*, *Beacon Hill*, *Ontario*, *Stettler*, *Saguenay*, *Antigonish*, *Cape Breton*; retired Nov. 4, 1964.

CPO JAMES ALVIN GUISE, CD, C2WS4; served in RCNVR Dec. 28, 1943-Jan. 25, 1946; joined RCN Feb. 13, 1947; served in *Prevost*, *York*, *Cornwallis*, *Scotian*, *Peregrine*, *Captor II*, *Brunswick*, *Chippawa*, *Naden*, *Rockcliffe*, *Ontario*, *Stadacona*, *Magnificent*, *Haida*, *Shearwater*, *Micmac*, *Ottawa*, *Columbia*, *Athabaskan*; retired Nov. 18, 1964.

PO JOHN DOUGLAS HYSLOP, CD; P1RM3; served in RCN Aug. 19, 1940 to Feb. 10, 1948; rejoined RCN March 28, 1949; served in *Stadacona*, *Naden*, *Prince Henry*, *Givenchy*, *Prince Robert*, NOIC Esquimalt, *Quatsino*, *St. Hyacinthe*, *Strathroy*, *Niobe*, *Crusader*, *Burrard*, *Bytown*, *Scotian*, *Nootka*, *Albro Lake*, *Lloyd George*, *Warrior*, *Prevost*, *Gloucester*, *Coverdale*, *Massett*, *Magnificent*,

HMS Dolphin, *HMS Adamant*, *Cornwallis*, *Lauzon*, *Athabaskan*, *Bonaventure*; retired Nov. 26, 1964.

CPO CHARLES JOSEPH KEEN, CD; C1ER4; joined RCNVR April 18, 1938; transferred to RCN June 28, 1940; served in Calgary naval division, *Naden*, *Wetaskiwin*, *Stadacona*, *Cornwallis*, *Hunter*, *Hochelaga*, *Longueuil*, *Peregrine*, *Goderich*, *Shelburne*, *Montreal*, *St. Stephen*, *Charlottetown*, *Rockcliffe*, *Antigonish*, ML-124, *Ontario*, *Porte Quebec*, *Skeena*, *Royal Roads*, *Skeena*, *Bonaventure*, *Sussexvale*; retired Nov. 8, 1964.



PO GORDON EARL MASON, CD and 1st Clasp; P1AM3; served in RCNVR Oct. 4, 1938-Dec. 4, 1945; joined RCN May 6, 1946; served in Ottawa naval division, *Stadacona*, *St. Croix*, *Cobalt*, *Baddeck*, *Hochelaga II*, *Drummondville*, *Swift Current*, *Prince Henry*, *Naden*, *Protector*, *Regina*, *Nipigon*, *Niobe*, *HMS Vernon*, *Bowmanville*, *Cornwallis*, *Carleton*, *Scotian*, *Bytown*, *Magnificent*, *CANAS Dartmouth*, *Shearwater* (19 CAG) (18 CAG) (30 CAG) (31 SAG) (1 TAG) (VU 32) (VT 40) (VF 871) (VS 881) (VS 880) (VU 33); retired Nov. 19, 1964.

CPO JOHN CORNELIUS MULVIHILL, CD; C1FC4; joined RCNVR Oct. 31 1941; transferred to RCN May 1, 1942; served in *Star*, *Nonsuch*, *Stadacona*, *Cornwallis*, *Givenchy*, *Naden*, *Bellechasse*, *Peregrine*, *Chilliwack*, *Uganda*, *Scotian*, *Warrior*, *Haida*, *York*, *Bytown*, *Algonquin*, *Fundy*, *Cape Scott*; retired Nov. 27, 1964.

CPO DONALD WILLIAM THOMAS ROSS, CD; C1WU4; joined RCNVR Sept. 13, 1943; transferred to RCN June 21, 1944; served in *York*, *Cornwallis*, *Stadacona*, *Niobe*, *HMS Duke of York*, *HMS Norfolk*, *Peregrine*, *Ontario*, *Naden*, *Bytown*, *Antigonish*, *New Glasgow*, *Stettler*, *Mackenzie*; retired Nov. 30, 1964.

CPO WILLIAM GEORGE SANDERSON, CD; C1WU4; joined Feb. 19, 1945; served in *Prevost*, *Chippawa*, *Cornwallis*, *Peregrine*, *Niobe*, *HMS Excellent*, *Crusader*, *Crescent*, *Stadacona*, *New Liskeard*, *Haida*, *Huron*, *Micmac*, *Stadacona*, *Crescent*, *Naden*, *Cap de la Madeleine*, *Patriot*; retired Nov. 15, 1964.

CPO ERNEST ERIC WATSON CD; C1WS4; joined RCNVR March 23, 1942; transferred to RCN Nov. 9, 1944; served in Halifax naval division, *Stadacona*, NOIC Sydney, *St. Hyacinthe*, *Cornwallis*, *Quebec*, *Iroquois*, *Atwood*, *Peregrine*, *Micmac*, *Niobe*, *HMS Excellent*, *Nootka*, *La Hullose*, *Huron*, *Bytown*, *Bonaventure*; retired Nov. 25, 1964.

PO RAY JAMES WILKIE, CD; P1ER4; joined April 2, 1945; served in *Tecumseh*, *Donnacona*, *Cornwallis*, *Stadacona*, *Niobe*, *Warrior*, *Cayuga*, *Rockcliffe*, *St. Stephen*, *Crescent*, *Iroquois*, *Naden*, *Sault Ste. Marie*, *St. Therese*, *Sussexvale*, *Lauzon*, *Lanark*, *Stettler*, *Inuvik*, *Saskatchewan*; retired Nov. 12, 1964.

CPO KENNETH HAROLD WOODFORD, CD, C2ER4; joined September 16, 1940; served in *Naden*, *Dawson*, *Givenchy*, *Prince Robert*, *Peregrine*, *Stadacona*, *Uganda*, *Rockcliffe*, *Nonsuch*, *Ontario*, *Antigonish*, *Cayuga*, *Stettler*, *Sussexvale*, *Crusader*, *Bonaventure*, *Cape Breton*, *Saguenay*, *Skeena*; retired Nov. 11, 1964.

OFFICERS RETIRE

LT.-CDR. HARRY GEORGE BISSKY, CD commenced service in the RCNVR on March 16, 1940, as an engine room artificer 4th class; transferred to RCN on Nov. 14, 1940; promoted to acting commissioned (L) officer on Dec. 17, 1951; served in *Naden*, *Sans Peur*, *Stadacona*, *HMS Vernon*, *Barrie*, *Restigouche*, *Avalon*, *Niobe*, *Peregrine*, *Warrior*, *Donnacona*, *Rockcliffe*, *Ontario*, *Sioux*, *Cornwallis*, *Quebec*, *Cayuga*; last appointment, HMCS *Naden*, on staff of Commodore Superintendent for Engineering Department Ship Repair Activity; commenced leave Nov. 25, 1964; retires on June 8, 1965.

LT.-CDR. FREDERICK GEORGE DOUGLAS, CD; commenced service in the RCNVR on May 2, 1934, as an ordinary seaman; transferred to RCN Jan. 8, 1936; promoted to acting warrant radio officer on Jan. 1, 1948; served in *Stadacona*, *HMS Victory*,

Saguenay, *Venture*, *Protector*, *St. Hyacinthe*, *Scotian*, *Niobe*, *Warrior*, *Ontario*, *Naden*, *Cornwallis*, *Bytown*, *Crusader*, *Crescent*, *Hochelaga*; last appointment, HMCS *Naden* on staff of Commodore Superintendent Pacific for Production Department Ship Repair Activity; commenced leave Nov. 22, 1964; retires on July 8, 1965.

LT.-CDR. ARTHUR GRAHAM HOLLAND, CD; commenced service in the RCNVR on May 28, 1943, as an ordinary seaman; promoted to sub-lieutenant on March 21, 1944; served in *Naden*, *Prevost*, *Cornwallis*, *Cartier*, *Kings*, *Brantford*, *Stadacona*, *Peregrine*, *Hunter*, *York*; demobilized Sept. 13, 1947; entered RCN(R) as acting lieutenant, July 2, 1948; transferred to RCN as lieutenant (SB) March 12, 1951; served in *Hunter*, *Stadacona*, *Bytown*, *Naden*, *St. Laurent*, *Prevost*, *Star*; last appointment HMCS *Naden*

on staff of Training Officer; commenced leave Nov. 29, 1964; retired on March 26, 1965.

LT.-CDR. WILSON FREDERICK JOBSON, CD; commenced service in the RCNVR on June 22, 1941, as a writer; promoted to probationary paymaster sub-lieutenant on Aug. 15, 1942; served in *Naden*, *Stadacona*, *Cornwallis*, *Niobe*, *Bytown*; entered RCN(R) as lieutenant (S) on Aug. 26, 1946; transferred to RCN as lieutenant (S) on Aug. 19, 1948; served in *Naden*, *Malahat*, *Magnificent*, *Stadacona*, *Bytown*, *Niobe*; last appointment HMCS *Bytown* on attachment to Civil Service Commission for Pay Research Bureau; commenced leave Nov. 2, 1964; retires on March 20, 1965.

LT. KEITH GEORGE McKEY, commenced service on Apr. 27, 1951 in the RCN(R);

transferred to RCN as cadet (L) on Jan. 8, 1954; served in *Malahat, Naden, Stadacona, Shearwater, Magnificent, Cataragui, Star, Ontario, Prevost, Niagara, Bonaventure*; last appointment, *Stadacona*; retired on Nov. 3, 1964.

LT.-CDR. KENNETH CAMPBELL McMARTIN, commenced service July 2, 1953, in RCN(R) as sub-lieutenant (E); transferred to RCN July 3, 1953; served in *Niobe, Bytown, Micmac, Quebec, Stadacona, Cornwallis, Ottawa, Naden, Kootenay*; last appointment Naval Headquarters on staff of Assistant Director Marine and Electrical Engineering Mechanical Equipment for Auxiliary Machinery; commenced leave on Nov. 30, 1964; retires on Feb. 18, 1965.

LT.-CDR. ROBERT THOMAS McNULTY, CD; commenced service in the RCNVR on July 28, 1941, as an ordinary seaman; promoted to probationary sub-lieutenant Nov. 9, 1942; demobilized April 3, 1946; served in *Naden, Givenchy, Kings, Fort Ramsay, Corn-*

wallis, Bytown, Captor, Hochelaga, St. Boniface, Stadacona, Chippawa; entered RCN(R) as lieutenant Feb. 26, 1947; transferred to RCN Jan. 31, 1951; served in *Donnacona, Stadacona, Iroquois, Bytown, Carleton, Prevost, Portage, La Hullose, Portage, Haida, Bytown*; last appointment Naval Headquarters on staff of Director Naval Manning as Assistant Director Naval Manning, Personnel Selection; commenced leave Nov. 22, 1964; retires on May 4, 1965.

LT. RICHARD HERBERT MEADOWS, CD; commenced service in the RCNVR Oct. 26, 1940; transferred to RCN May 20, 1941, as a shipwright 4th class; served in *Naden, Givenchy, Burrard, Scotian, Stadacona, Niobe*; promoted to acting commissioned constructor Feb. 23, 1953; served in *Niobe, Magnificent, Stadacona, Naden, Quebec, Cornwallis*; last appointment, HMCS *Naden*, on staff of Commodore Superintendent Pacific for Planning Department Ship Repair Activity; commenced leave Nov. 9, 1964; retires on May 26, 1965.

LT.-CDR. JOHN JAMES TANNER, CD; commenced service in the RCN Sept. 1, 1933; rank on joining stoker, 2nd class; promoted to acting warrant engineer March 15, 1945; served in *Naden, Vancouver, Skeena, St. Laurent, HMS Drake II, Windflower, Avalon, Stadacona, Courtenay, Nonsuch, Ungava, Port Arthur, Oshawa, Glace Bay, Leaside, Givenchy, Warrior, Niobe, Magnificent, Rockcliffe, Cornwallis, Bytown, Beacon Hill, Fraser*; last appointment, Naval Headquarters on staff of Assistant Director Fleet (Maintenance); commenced leave Nov. 1, 1964; retires on June 5, 1965.

LT.-CDR. GEORGE HOWARD VERGE, CD; commenced service in the RCN on Jan. 22, 1937, as acting ordnance artificer 4th class; promoted to acting warrant ordnance officer on Aug. 1, 1943; served in *Stadacona, Saguenay, HMS Excellent, Ottawa, Naden, Skeena, Cornwallis, Protector, HMCS Uganda, Iroquois, La Hullose, Haida, Huron, Cape Breton, Bytown, Gatineau*; last appointment, HMCS *Stadacona* on staff of Commodore Superintendent; commenced leave Nov. 16, 1964; retires on June 4, 1965.



A memorable event during the visit to Victoria of 150 members of the Union of Municipalities of Quebec was a Sunday luncheon at the Canadian Services College, Royal Roads. The visitors watched a parade in their honour by the officer cadets of the college and made a tour of the college gardens. (RR-3565)

Naval Lore Corner

Number 133 W.W.I BATTLESHIPS OF THE 'LESSER NAVIES'

THE MAJOR FLEETS OF WORLD WAR I OVERSHADOWED THE SMALLER NAVIES ENGAGED IN THE GREAT CONFLICT. HERE ARE SOME OF THE MAJOR UNITS OF THE SMALLER COMBATANTS...

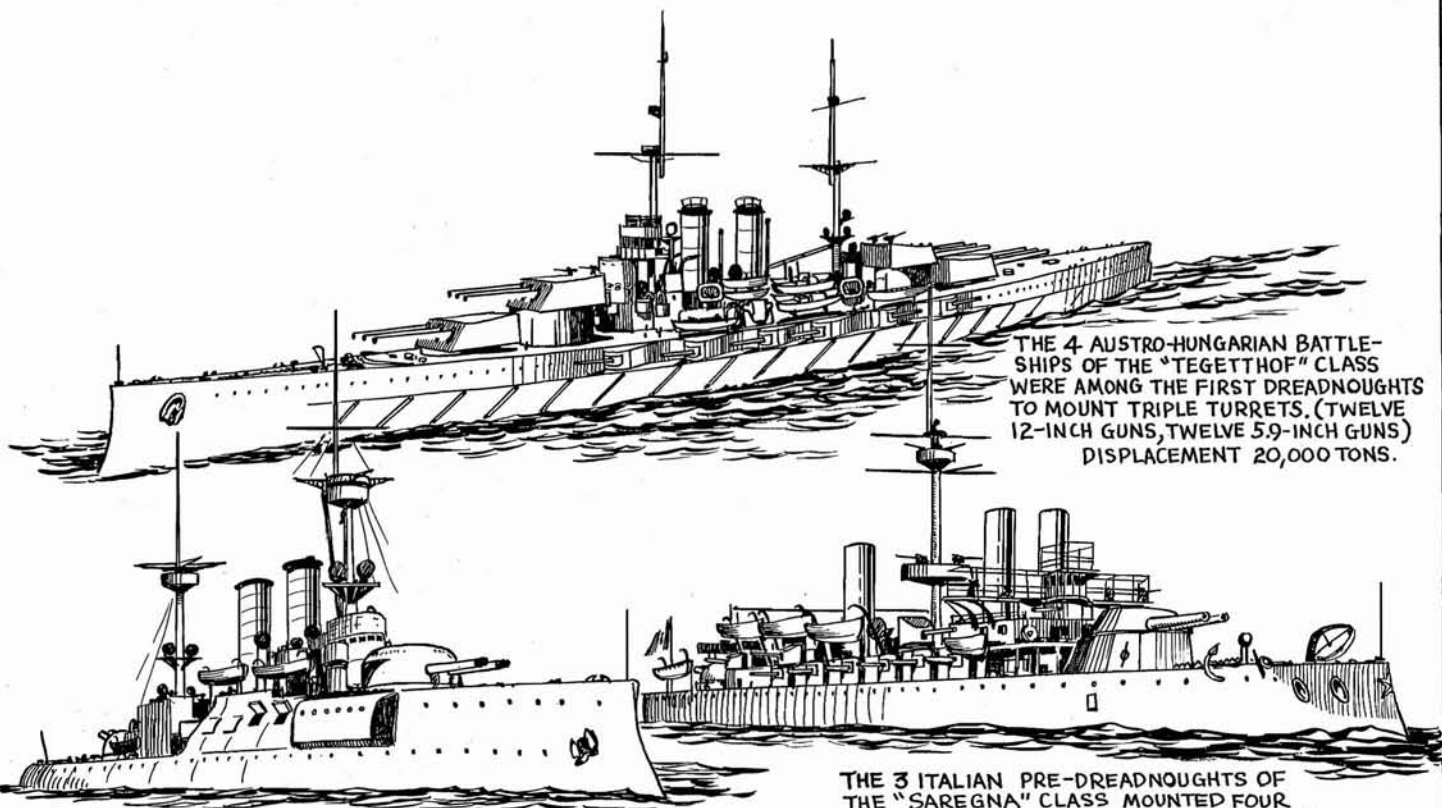

THE 4 AUSTRO-HUNGARIAN BATTLESHIPS OF THE "TEGETTHOF" CLASS WERE AMONG THE FIRST DREADNOUGHTS TO MOUNT TRIPLE TURRETS. (TWELVE 12-INCH GUNS, TWELVE 5.9-INCH GUNS) DISPLACEMENT 20,000 TONS.

THE TURKISH PRE-DREADNOUGHT "HAIRREDIN BARBAROSSE" (EX-GERMAN "KURFUST FRIEDRICH WILHELM") WAS SUNK IN THE SEA OF MARMORA BY THE BRITISH SUBMARINE E-II. SHE MOUNTED SIX 12-INCH GUNS ON A DISPLACEMENT OF 10,060 TONS

THE 3 ITALIAN PRE-DREADNOUGHTS OF THE "SAREGNA" CLASS MOUNTED FOUR 13.5-INCH GUNS AND EIGHT 6-INCH GUNS ON A DISPLACEMENT OF 13,250-13,860 TONS. THE FORWARD TWO FUNNELS WERE POSITIONED SIDE BY SIDE...

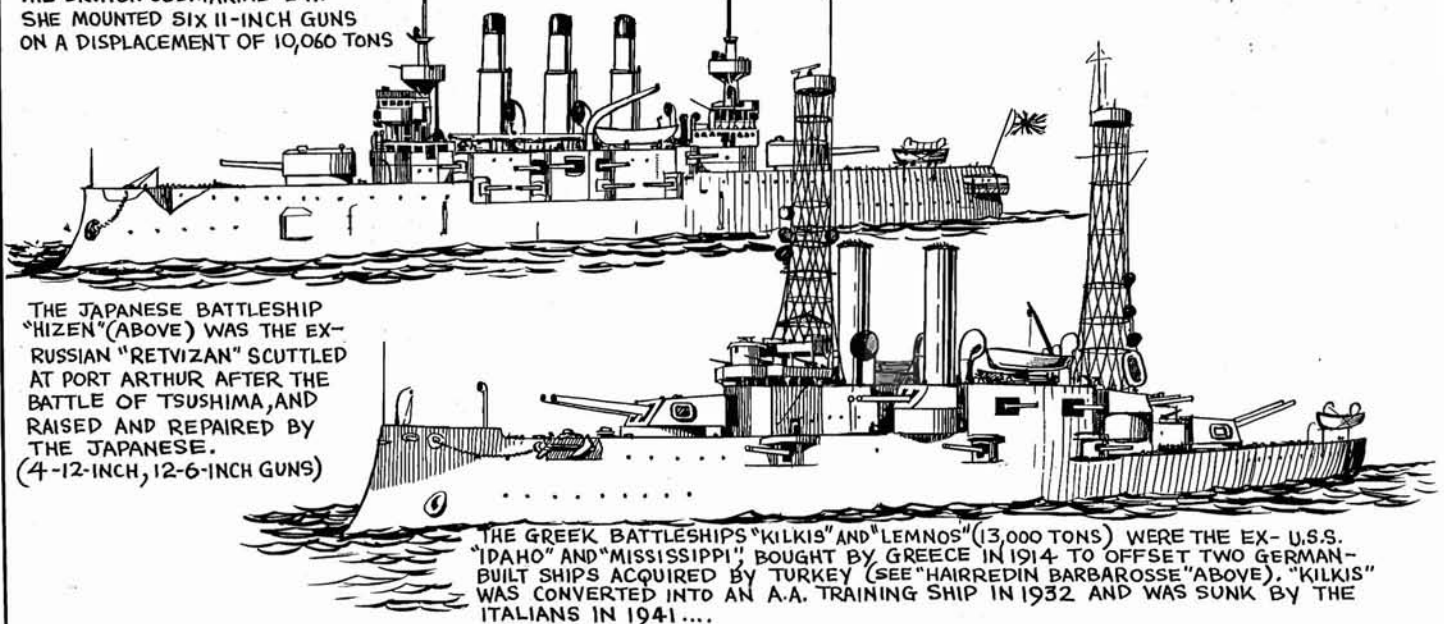

THE JAPANESE BATTLESHIP "HIZEN" (ABOVE) WAS THE EX-RUSSIAN "RETVIZAN" SCUTTLED AT PORT ARTHUR AFTER THE BATTLE OF TSUSHIMA, AND RAISED AND REPAIRED BY THE JAPANESE. (4-12-INCH, 12-6-INCH GUNS)

THE GREEK BATTLESHIPS "KILKIS" AND "LEMNOS" (13,000 TONS) WERE THE EX-U.S.S. "IDAHO" AND "MISSISSIPPI", BOUGHT BY GREECE IN 1914 TO OFFSET TWO GERMAN-BUILT SHIPS ACQUIRED BY TURKEY (SEE "HAIRREDIN BARBAROSSE" ABOVE). "KILKIS" WAS CONVERTED INTO AN A.A. TRAINING SHIP IN 1932 AND WAS SUNK BY THE ITALIANS IN 1941....

CANADA
POSTAGE PAID
PORT PAYÉ



*If undelivered,
return COVER WITH CONTENTS to:*

The Queen's Printer, Ottawa, Canada

*En cas de non-livraison,
retourner cette PUBLICATION INTACTE à:*

L'Imprimeur de la Reine, Ottawa, Canada



The CROWSNEST

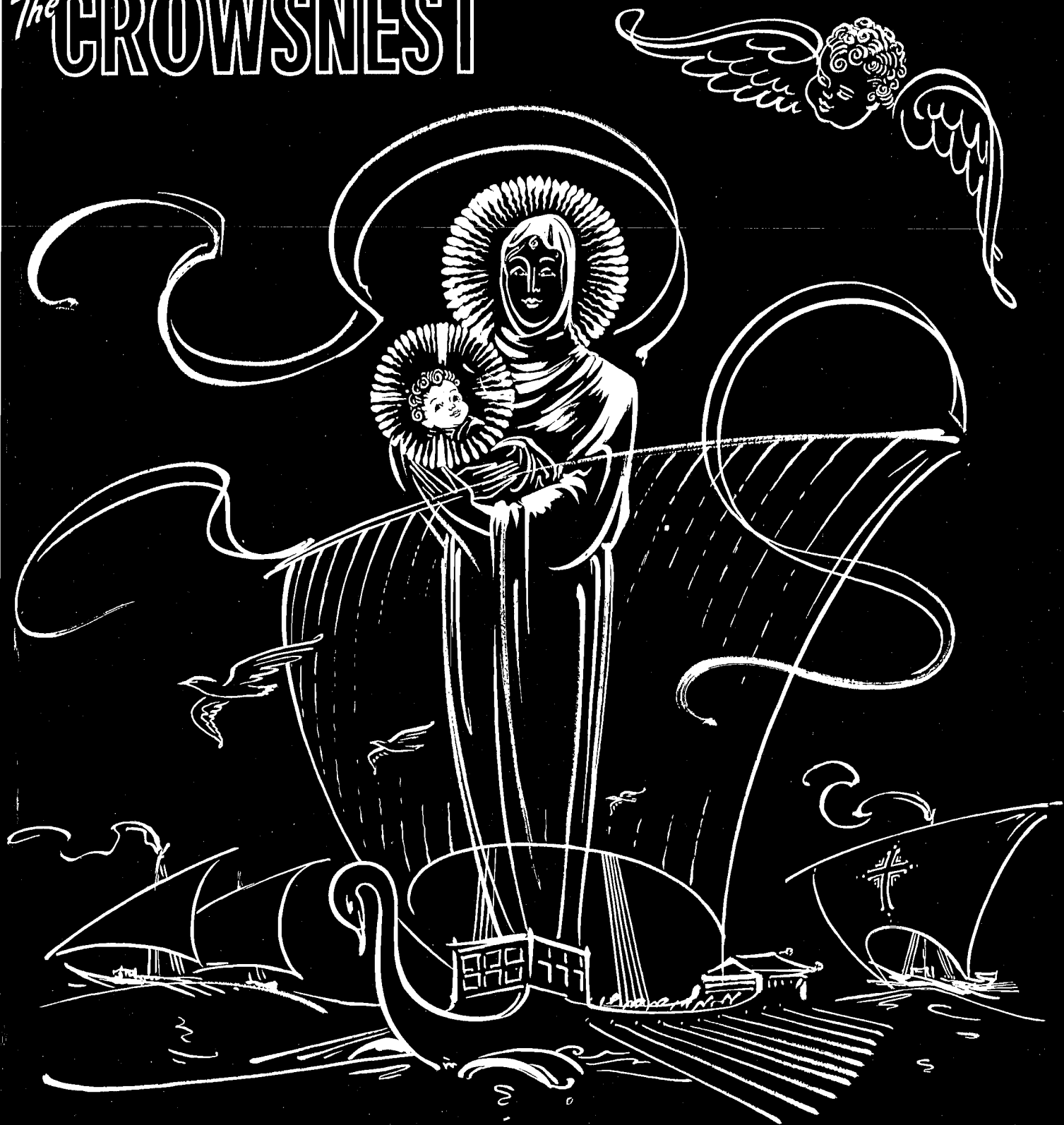

I SAW THREE SHIPS COME SAILING BY
ON CHRISTMAS DAY IN THE MORNING...



Christmas Messages

From Hon. Paul T. Hellyer, Minister of National Defence:

DURING THE YEAR which is now drawing to a close, a great many changes have taken place both within the Armed Forces of Canada and throughout the world. No doubt each of you feels that the most noteworthy events are the ones which affect you personally.

"The old order changeth" and I trust that the new, which is embodied in the integration of the Canadian Forces Headquarters and other establishments, will help us to provide the most streamlined and responsive force possible to preserve the peace.

The preservation of peace in the world today can best be achieved by each and every one of us being prepared to make the sacrifices necessary to ensure that all nations live in harmony one with another.

Christmas is the time of year when thoughts turn to home, family and loved ones particularly when one is far from home as some of you are, and unable to participate in the festive celebrations which are so much a part of our tradition and way of life.

As Minister of National Defence, it gives me great pleasure to extend to each and every one of you and your families, my most sincere wishes for a Very Merry Christmas and a Happy New Year.

From Hon. Lucien Cardin, Associate Minister of National Defence:

IT GIVES ME great pleasure to extend my best wishes for a Merry Christmas to the members of Canada's armed forces, to the personnel of the Defence Research Board and to the civilian staff of our Department.

All of you are sharing in the common effort towards the maintenance of peace throughout the world. I know that on occasion this can entail hardships, and at this glad season of the year some of you will be separated from families and loved ones because you are stationed in foreign lands.

During the holy season of Christmas the divine proclamation of peace on earth and good will to all men is reflected in your efforts to bring peace and understanding to many troubled areas. The observance of the birth of the Saviour gives each and every one of us an opportunity to reassess our purposes and aims in the light of the requirements for living in the world of today.

To each of you, wherever you may be, may the Christmas season be a festive one and may the New Year bring us all nearer to peace and prosperity.

The CROWSNEST

Vol. 16 No. 11

THE ROYAL CANADIAN NAVY'S MAGAZINE

NOVEMBER 1964

CONTENTS

	Page
<i>RCN News Review</i>	2
<i>Royal Visit 1964</i>	5
<i>WUPS and the Padre</i>	8
<i>Officers and Men</i>	9
<i>Marriages and Births</i>	9
<i>Coast Commands Change</i>	12
<i>Helping Children</i>	14
<i>Troop Convoy</i>	16
<i>Afloat and Ashore</i>	21
<i>Here and There in the RCN</i>	24
<i>The Navy Plays</i>	25
<i>Retirements</i>	27
<i>Naval Lore Corner No. 132</i>	<i>Inside Back Cover</i>

The Crownsnest
Extends
to Its Readers
All Best Wishes
for
Christmas
and
the New Year

Negative numbers of RCN photographs reproduced in *The Crownsnest* are included with the caption for the benefit of persons wishing to obtain prints of the photos.

This they may do by sending an order to the Secretary Defence Staff, Canadian Forces Headquarters, Ottawa, quoting the negative number of the photograph, giving the size and finish required, and enclosing a money order for the full amount, payable to the Receiver General of Canada.

Sizes, finish and the National Defence standardized prices, follow:

4 x 5 (or smaller) glossy finish only ..	\$.10
6½ x 8½ glossy finish only40
8 x 10 glossy or matte finish50
11 x 14 matte finish only	1.00
16 x 20 " " "	3.00
20 x 24 " " "	4.00
30 x 40 " " "	8.00

SUBSCRIPTION RATE

The Crownsnest may be subscribed for at the rate of \$2 a year; outside of North America, \$3. Orders, accompanied by cheque or money orders payable to the Receiver General of Canada, should be sent to:

THE QUEEN'S PRINTER,
OTTAWA, Ontario,
Canada

Communications, other than those relating to subscriptions, should be addressed to:

EDITOR,
The Crownsnest,
Canadian Forces Headquarters,
OTTAWA, Ontario.

The Cover—In the ancient carol, "I saw three ships come sailing by," the words relate that "Joseph did whistle and Mary did sing, And all the bells on earth did ring"—truly a quaint but vivid expression of the joyousness of the Christmas season.



RCN NEWS REVIEW

The new Flag Officer Pacific Coast, Rear-Admiral M. G. Stirling, takes the salute as the band of HMCS Naden marches past, followed by a 48-man honour guard. At the far right is Rear-Admiral W. M. Landymore, who has become Flag Officer Atlantic Coast. (E-78534)

Cadet Training Programs Combined

The combined ROTP, UNTD, COTC and URTP cadets of the Navy, Army and RCAF attended divisional drill and instruction on board HMCS *Scotian*, Halifax naval division, on the evening of Oct. 28.

This was the first evening of a combined officer cadet training program which will be carried out at *Scotian* during the 1964-65 winter training season.

The commanding officers of *Scotian* and the UNTD of Halifax Universities and Colleges, Cdr. Bruce Oland and Lt.-Cdr. R. C. MacLean respectively, addressed the cadets and their officers, welcoming them on board the naval reserve division in Halifax.

HMCS Annapolis To Enter Service

The 20th ship of a postwar construction program of destroyer escorts for the RCN HMCS *Annapolis* will be commissioned Dec. 19 at Halifax Shipyards Limited. The ship bears the name of a river in Nova Scotia and perpetuates the name of a Second World War destroyer of the Canadian Navy.

The program of destroyer escorts of Canadian design and construction began with the laying down of HMCS *St.*

Laurent, name ship of the seven in her class, in 1950 at Canadian Vickers Ltd., Montreal. Seven more advanced Restigouche destroyer escorts came off the

RCN Coats for Chilled 'Aussies'

When that cold Arctic weather funnels down Lake Huron this winter, 11 Australian seamen will be thanking the Royal Canadian Navy.

The "Aussies" are standing by while a Secretary class guided-missile destroyer is built for their navy at Bay City, Michigan. They have no uniform greatcoats as this is not an issue garment in the RAN. The Australian naval attaché in Washington asked the RCN to lend them RCN coats for the winter months.

No sooner was the request relayed from the Canadian Joint Staff in Washington than arrangements were made to have the greatcoats made available from the Naval Supply Depot, Montreal.

Even the less extreme climate of the East Coast during the Second World War took its toll of the fighting men from "Down Under" some of whom deployed through Halifax to theatres of war. Aussies and New Zealanders in Halifax during the winter months were permitted to parade with coat collars turned up, for instance.

As the cold fronts march through Michigan these days, the Aussies will be ready for the greatcoats. Perhaps long underwear, too?

ways of Canadian shipyards, followed by four of the further improved MacKenzie class.

The new *Annapolis* is the name ship of yet another class incorporating in the construction stage a hangar and flight deck for the all-weather operation of the Sea King anti-submarine turbine-powered helicopter. The ship also has variable depth sonar. A sister ship, HMCS *Nipigon*, was commissioned in May at Sorel, Que.

Ships of the original St. Laurent class are being converted to the same configuration so that they can match the capabilities of the most modern submarines.

The original HMCS *Annapolis* was one of the 50 destroyers the United States exchanged with Britain for the lease of strategic bases off the North American coast in the Second World War. She and six others were commissioned and manned by the RCN. The first *Annapolis* served on escort duties in the western Atlantic, 1940-44, and in 1944-45 was a training ship at HMCS *Cornwallis*.

Cyclic System Drafts Begin

The redistribution of men within the Atlantic Command, preparatory to the introduction of the Cyclic System, began on Nov. 9 with the drafting of men

to their new ships. It was hoped to complete the drafts by Nov. 16.

Some of the drafting had taken place earlier, in the case of the *Bonaventure*, *Provider*, *Cape Scott* and *Columbia*, because of the particular employment of these ships.

Although an effort is being made to keep drafting changes to a minimum, it was estimated that approximately 30 to 50 per cent of men serving in ships would receive drafts.

In the Pacific Command, Cyclic System drafting was scheduled for early December.

Joint Exercise Held at Argentina

Exercise Yeoman, largest Navy-Army-RCAF exercise since the Second World War, was held Oct. 25 to Nov. 8 in the region of the U.S. Navy base at Argentina, Nfld.

In addition to nine ocean escorts from Halifax and the fleet replenishment ship *Provider*, which was also used for transport of men and matériel there were some 450 personnel from Camp Gagetown. The RCAF, RCMP and Newfoundland Rangers also took part, as did U.S. Marine Corps personnel of Argentina naval base.

The manner in which forces participating in the exercise carried out their duties was the subject of a congratulatory message by the Maritime Commander Atlantic, Rear-Admiral J. V. Brock.

"I wish to congratulate all personnel who participated in Exercise Yeoman on the manner in which they carried out their assigned tasks," the message said.

"As you know, this exercise was the third in a series of joint exercises planned by Cancomarlant in conjunction with Eascom and Canairlant. It was designed to practice Canadian

forces in more advanced and complex combined operations than were encountered in Exercises Boat Cloak and Mowhawk and to provide an opportunity for Canadian forces to work in close co-operation with the U.S. ground defence elements at the Naval Station Argentina.

"I was very pleased with the enthusiasm and spirit prevailing during my own visit to units in the exercise area. The problems presented by somewhat adverse weather conditions and difficult terrain brought forth individual responses by all officers and men which were gratifying to see.

"On behalf of the Canadian participants I would like to extend a special thanks to the U.S. forces for their whole-hearted support and for the many services they performed in answer to unforeseen requirements."

The message made special mention of the participation of the Canadian Rangers and RCMP from the Newfoundland area in the exercise.

Reorganization of Reserve Training

The following is the text of a statement made by Defence Minister Paul Hellyer to the Special Committee on Defence in Ottawa Nov. 3:

"YOU WILL RECALL that in February of this year the Ministerial Committee on the Role and Organization of the Royal Canadian Naval Reserve, chaired by Commodore R. I. Hendy, (RCNR, Ret'd), tabled its report. As a result of recommendations contained in the Committee's report, an increase in the complement of the RCNR was authorized and two RCNR divisions scheduled for closure were retained. The question of the remaining divisions scheduled for closure following the December 1963 announcement of RCNR reductions, was to be studied further.

"As a result of these studies it has been decided that the RCNR complement is sufficient for the Naval Reserve's allotted tasks. It will not be necessary, therefore, to retain the RCNR divisions scheduled for closure, or to increase the RCNR complement to its previous level. Accordingly, the RCNR complement has been established at 2,925 officers, men and wrens. The RCNR Divisions HMCS *Prevost* (London), *Queen* (Regina), *Non-such* (Edmonton), *Queen Charlotte* (Charlottetown) and the Kitchener tender HMCS *Star* are being closed as originally planned.

"It is expected that the reductions will yield savings in the order of \$1.8 million annually. A total of 1,675 RCNR personnel have been affected by these reductions and approximately 80 regular force personnel have been made available for other duties."

Mr. Hellyer's announcement of the decisions on the RCNR was combined with a statement on the RCAF Auxiliary. Two RCAF Auxiliary squadrons at Montreal, two at Toronto and one each at Winnipeg

and Edmonton were to be retained. Two at Vancouver and one each at Hamilton, Saskatoon and Calgary would be closed. The annual saving was calculated at approximately \$6.4 million; 2,490 auxiliary personnel would be affected; 576 positions for regular force personnel would become available for re-assignment.

Preceding the RCNR-RCAF Auxiliary statement was a lengthy statement on the re-organization of the Canadian Army (Militia).

The decisions with respect to the Militia were reached following extensive study at Defence Headquarters of the report of the Commission on the Re-organization of the Canadian Army (Militia), better known as the Suttie Report.

Among the many highlights of the statement on the new look militia were:

- The Militia to be soldiers first, with more emphasis on military corps training, but with continuing responsibility for a national survival role.
- A closer working relationship with the Regular Army.
- More and better training equipment.
- Lower age limits for qualification and promotion.
- Higher medical standards.
- Physical fitness to be stressed.
- Logistic and service units to be streamlined; many service units to be merged into Service Battalions.
- Accommodation costs reduced.
- A net reduction of 58 major and 15 minor Militia units.
- Strength to be approximately 30,000 based on an establishment of 41,742 (as compared with a previous ceiling of approximately 90,000).
- Estimated annual savings of \$8,700,000.

Shipping Control Exercise Held

Hundreds of officers and men of five navies maintained day and night watches over the Nov. 1 week-end to exercise the control of merchant shipping in the Pacific and Indian Oceans.

They were taking part in the naval control of shipping Exercise Radiator Cap, involving the navies of Australia, Britain, Canada, New Zealand and the United States.

The exercise was co-ordinated from Australian Naval Headquarters in Canberra and was designed to evaluate an integrated, five-nation control of shipping organization in time of war, an organization that would control allied shipping in more than 90 million square miles of the Pacific and Indian Oceans.

During the exercise, naval control of shipping officers at principal ports throughout the area planned the control and direction of some 930 ships. Altogether in the exercise, a total of 3,000 ships were involved. However, Radiator Cap was intended to test the highly complex control organizations, and there was no requirement in the exercise for the diversion of actual ships.

Four Vessels on Seattle Cruise

The training yacht *Oriole* left her base at Esquimalt on Nov. 6 for a training cruise to Seattle, Washington.

In company with the *Orioles* were three naval auxiliary vessels, *YMT-10*, *YFP-312* and *YFP-320*. The four vessels returned to Esquimalt on Nov. 8.

On board were 42 young Short Service Officer Plan cadets from HMCS *Venture*. For most of them, it was their first taste of life at sea. They make up about half of the cadets currently under training at *Venture*.



Dr. H. D. Roberts (left) of St. John's, Newfoundland, newly elected national president of the Navy League of Canada, presents an unusual sterling silver tray to Cdr. F. C. and Mrs. Aggett, Toronto, on Cdr. Aggett's retirement as national president, an office he had held for three years. Engraved on the tray are facsimiles of signatures of the Prime Minister of Canada, the Minister of National Defence, Lieutenant-Governors and Premiers of all provinces, members of the Naval Board and the League's national officials. The occasion was the 69th Annual Meeting of the Navy League of Canada in Edmonton.

While at sea, the cadets underwent training in pilotage and navigation, officer-of-the-watch manoeuvres, signal flag hoisting and radio voice procedures.

The 42 cadets are members of *Venture's* Grant and Brodeur divisions. They were accompanied by their divisional officers, Lt.-Cdr. J. I. Gallant and Lt. David Lee.

HMCS *Oriole* is commanded by Lt.-Cdr. W. D. Walker.

YMT-10 is under PO Gordon Troughton; *YFP-312* is commanded by Chief Petty Officer E. H. Aubrey; *YFP-320* is in charge of Ldg. Sea. William Big Canoe, a member of the Ojibwa, or Chippawa, tribe of Ontario. A bosun, he has spent 12 years in the Royal Canadian Navy and has been on the staff of the auxiliary training fleet for two years.

Newfoundlander Heads Navy League

A Newfoundland physician, Dr. H. D. Roberts of St. John's was elected national president of the Navy League of Canada on Oct. 16 at the annual meeting in Edmonton.

Dr. Roberts, 56, has been the league's first vice-president for three years. He has been active in the league since the union of Newfoundland with Canada. Succeeding him as first vice president is an Edmontonian, Thomas E. Waddington, a former league second vice-president and member of the board of management, Edmonton.

The retiring president Cdr. F. C. Aggett, of Toronto, was honoured at

the conclusion of his three-year term by presentation of a silver tray.

The tray has more than 100 engraved signatures, including those of Prime Minister Pearson and Hon. Paul Hellyer, Minister of National Defence.

The tray also bears the signatures of all Canadian provincial premiers and lieutenant-governors, members of the naval board and the league's national officials.

The presentation was made by the new president.

West Coast Ships On ASW Training

Six ocean escorts and a submarine of the Pacific Command sailed on Monday, Nov. 9, for a two-week anti-submarine warfare training cruise off the west coast of North America, a cruise that was to take them to San Francisco, and Vancouver, B.C.

The ocean escorts are units of the Fourth Canadian Escort Squadron, under the command of Captain E. P. Earnshaw. The ships were the *Sussexvale*, *New Glasgow*, *Jonquiere*, *Antigonish*, *Stettler* and *Beacon Hill*.

The squadron exercised at sea with the Pacific Command submarine HMCS *Grilse*.

The visit of the squadron and the submarine to San Francisco was scheduled for Nov. 13-15. The ships, with the exception of the *Grilse*, were to visit Vancouver Nov. 20-22, the submarine returning directly to Esquimalt from the exercises at sea.



ROYAL VISIT 1964

"With humble duty the Flag Officer Atlantic Coast, officers, men and civilians of the Atlantic Command offer to your most gracious Majesty loyal greetings and wishes for a safe and pleasant cruise in Canadian waters.

"Your Majesty's acceptance of the Commander First Canadian Escort Squadron with your Canadian ships Nipigon, Yukon, St. Laurent and Assiniboine as escort is an honour highly prized by those ships now in company."

THIS MESSAGE from Rear-Admiral Jeffrey V. Brock, Flag Officer Atlantic Coast, was forwarded to Her Majesty the Queen as the Royal Yacht *Britannia* and her four Canadian naval escorts proceeded from Summerside to Charlottetown for the start of Royal Visit, 1964.

The four destroyer escorts, units of the First Canadian Escort Squadron under the command of Captain John P. T. Dawson, had sailed from Halifax four days earlier to rendezvous with the *Britannia* in the Gulf of St. Lawrence.

ROYAL VERSION OF WAKEY, WAKEY

A new version of "Wakey, wakey" for use on a special occasion was reported in the Oct. 10 *Montreal Star* as follows:

Hands on board the destroyer *Nipigon*, one of the sleek Canadian destroyers in the Royal escort, hit the deck yesterday with a substitute for the traditional "Wakey, wakey, rise and shine" pipe of the bos'n's call.

After the shrilling squeal of the pipe through the ship the bos'n's mate recited:

*Wakey, wakey, up and at,
We're following the Royal yacht
Down St. Lawrence mighty fine,
Five good ships all in a line.
The day is clear, the water calm,
So stir yourselves without a qualm.
The dress for all is number threes,
So rise and cover up your knees.
A really great and Royal scene—
We'll man the ship and cheer the Queen.*

And that's exactly what each ship's company was to do later in the day as the destroyers passed in review.

The crews, lining the decks, gave three cheers for the sovereign.

The wakey-wakey jingle was written by young Sub-Lt. Peter King, of Montreal.



Her Majesty at Charlottetown. (HS-76407)

The Canadian ships met the *Britannia* on Sunday, Oct. 4, and Captain Dawson, in the *Nipigon*, transferred by jackstay to the Royal Yacht for conferences with Rear-Admiral Sir Joseph Henley, Flag Officer Royal Yachts. The ships remained in company until the following day, when the *Assiniboine* accompanied the *Britannia* to Summerside to await the arrival from England of the Queen and HRH the Duke of Edinburgh. The *Nipigon*, *Yukon*, and

St. Laurent waited over the horizon. Shortly after the Queen embarked in the *Britannia* on the evening of Oct. 5, Admiral Brock, who, with Mrs. Brock, had been presented to Her Majesty at RCAF Station Summerside, joined the *Assiniboine* for the passage to Charlottetown.

Early next morning, Oct. 6, under leaden skies, the *Britannia* weighed and sailed from Summerside, followed by the *Assiniboine*. The remainder of the

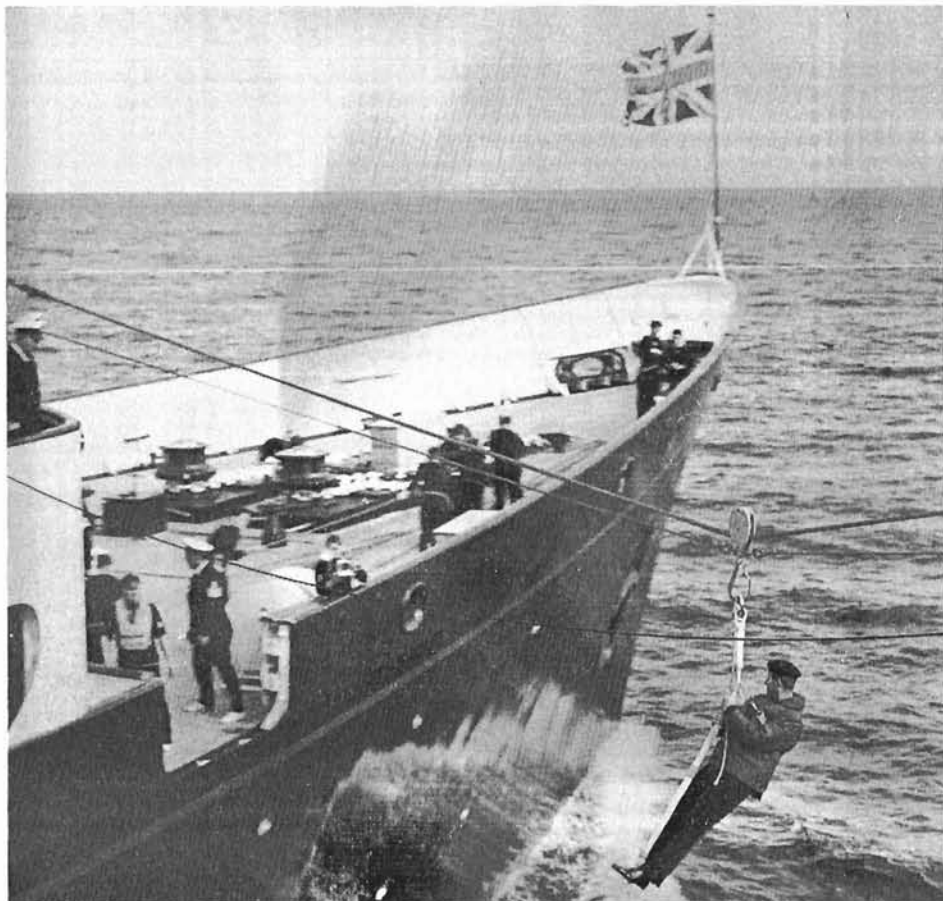

Following a hunting trip to a St. Lawrence River island, His Royal Highness the Prince Philip was flown by helicopter to HMCS Nipigon, where he visited for an hour before returning to HM Yacht Britannia by jackstay. Five representatives from each of the other escorting ships were on board the Nipigon for the occasion. (HS-76393)



"What's for dinner?" Prince Philip has a word with PO George Aucoin in the Nipigon's galley during the visit paid by His Royal Highness to the ship. (HS-76390)

Royal Escort joined shortly thereafter for the three-hour passage to Charlottetown.

In reply to Admiral Brock's message of welcome, Her Majesty messaged: "I am most grateful to you for your cordial greetings. I send my best wishes to you, the officers, men and civilians of the Atlantic Command."

The Royal Squadron arrived in Charlottetown at 1130, the *Britannia* berthing at the DOT Terminal and the escorts at the Railway wharf.

During the next two days of the Royal Visit to Charlottetown the ship's companies of the four Royal Escorts were a prominent part of the city scene. Each ship provided 50 men for street lining on the several occasions when Her Majesty's entourage travelled throughout the city.

Four men, two from the First Escort Squadron and two members of Admiral Brock's personal staff, had the honour of assisting at social functions for Her Majesty in Charlottetown. They were PO George Skelton, Ingramport, Halifax Co.; AB John R. Gorman, Dartmouth; PO D. E. Hoppe, HMCS *St. Laurent*, and PO D. J. Richardson, HMCS *Yukon*.

The Royal Squadron sailed from Charlottetown for Quebec City at midnight Oct. 7. As the *Britannia*, followed by the *Assiniboine*, *St. Laurent*, *Nipigon* and *Yukon*, left the Queen City, a display of colourful fireworks lighted the sky over Charlottetown. Seven rep-



Canadian sailors cheer ship as they steam past HM Yacht Britannia with Her Majesty Queen Elizabeth on board. There were reports that Her Majesty not only waved acknowledgement of the cheers but also snapped pictures of her RCN sailors. (HS-76381)

representatives of the press were embarked in the Canadian ships to cover the passage to Quebec City.

The squadron set course for Quebec City around the southern tip of Prince Edward Island. Next morning at daylight, under cloudy skies and moderate seas, the northeast tip of P.E.I. was off the port beam.

At noon, with Her Majesty's approval, the *Assiniboine's* helicopter, piloted by Lt. Gerry Watson of HU-21, took members of the press aloft for still and motion pictures of the Royal Squadron.

By dusk, the outline of Gaspé's rugged cliffs was visible 20 miles to the westward. Two hours earlier, a fishing smack, the only vessel sighted during the day, approached the Royal Squadron on an intersecting course. The *Britannia* and her escorts yielded the right of way.

Friday was to be the highlight of the two-day passage. The escort ships were to steam past, cheer and man ship for the Queen.

Precisely at 1200 the *Nipigon* led the escorts past the *Britannia*—overtaking the Royal Yacht at a distance of 125 yards off her port side. Her Majesty and the Prince Philip stood together on the *Britannia's* verandah deck and Her Majesty waved as officers and men from each ship gave three cheers for their Queen as the destroyer escorts came abeam of the Royal Yacht.

The manoeuvre was performed in the St. Lawrence, about eight miles off Mont Joli. The *Nipigon*, with Captain Dawson embarked, was followed by the *Yukon*, *Assiniboine* and *St. Laurent*.

Despite an icy wind off the river, Her Majesty remained to watch the destroyers return to their stations.

Throughout the remainder of the day, ships of many nations proceeding



HRH the Prince Philip chats with sailors on board the *Nipigon*. (HS-76389)

up river passed the Royal Squadron and dipped their flags to the *Britannia*. At 1700 the *Britannia* and her escorts embarked pilots off Les Scoumain. It was here that the Queen received her first Quebec welcome. More than 100 persons from the small community were observed on vantage points on the wharf and along the rocks to watch and wave.

The next morning the Royal Squadron sailed past Quebec City and berthed alongside at Wolfe's Cove. Admiral Brock, who had left the *Assiniboine* at Charlottetown, returned early on Saturday morning, embarking from an RCMP vessel before the Quebec arrival.

As Her Majesty left the *Britannia* for her Quebec City visit, the Canadian escorts, berthed ahead and astern of

the Royal Yacht, manned ship for the occasion. Later, the Canadian sailors lined portions of the routes followed by the Queen during her Quebec City visit.

Following the Royal Squadron's arrival in Quebec City, the Flag Officer Royal Yacht messaged the Canadian ships as follows:

"I am commanded to convey the following:

"It has given me very great pleasure to be escorted once again by ships of the Royal Canadian Navy. I am glad to be able to see you all as you steamed past and I congratulate you on the appearance of your ships and your ships' companies.

'Splice the mainbrace.'

Elizabeth R."

It had been a week long to remember.



Escorting RCN warships in formation astern of HM Yacht *Britannia* in the Gulf of St. Lawrence. (HS-76368)

WUPS AND THE PADRE

NOW I KNOW what "WUPS" really are. This came about as a result of my leaving Edmonton, where I was Chaplain (RC) with HMCS *Nonsuch*, travelling almost 1,000 miles west and finding myself in Saskatchewan. This time it was HMCS *Saskatchewan*, to which ship I was attached for naval training and special duty. It developed into one of the busiest two weeks I had experienced for a long time, as the ship had just finished refit and was in the midst of work-ups.

The ship is one of the new DDEs, part of the Second Canadian Escort Squadron, Pacific Command, and commanded by Cdr. M. W. Mayo. A fine spirit exists between all on board, something that is especially needed during the heavy and hectic days of work-ups when the ship is thoroughly put through its paces. As a special check-up, a team from the NBCD school was with us for a couple of days.

It was a beautiful day when we slipped from Jetty B, Esquimalt, but we were not out long when things started to happen. The idea behind the exercises is to find out what the ship can take and the same applies to the ship's company.

Weaknesses are supposed to show up and be rectified before the vessel is returned to regular service. On two occasions we had to put back to dockyard when faults were found in one of the guns and also one of the davits. This is an example of what work-ups are for, to find out these things before life and limb or the ship are jeopardized, in action or other emergency. Therefore, these events added to the value of the work-up exercises.

Each day had been a full day and at times one of the exercises had to be postponed or rescheduled, as there was not sufficient time to carry them out. We had action stations, deep shelter and raft stations; and we had mock warfare, simulated gas attacks, damage control stations, emergency stations, attack by underwater swimmers, air attack and anti-aircraft exercises, etc.; man overboard rescue procedure and, in conjunction with HMCS *Qu'Appelle*, jack-stay transfer, towing and other manoeuvres.

This sort of thing was repeated day after day in order to reduce the time in which the exercise could be completed. For instance, the first day it took nine minutes from the time the alarm was

by

Rev. J. E. McGrane, RCNR

given until the men were reported closed up at action stations and cleared away for action. After several more drills this time was reduced to less than three minutes. The submarine, HMCS *Grilse*, was with us for one day and we had underwater detection and plotting exercises.

One day the tables were turned and we became the enemy, taking the role of an "enemy" merchantman in Canadian waters and we were boarded by a party from the *Qu'Appelle*. We were ordered to offer only passive resistance. As part of this "resistance" those who spoke French were placed in the key positions and only French was to be used. If the boarding party did not speak French, then that would hinder matters and confuse them and so delay action.

This exercise took about one hour. The captain left the bridge and appointed me captain and then disappeared. I was rigged up in quite a uniform with a few coloured feathers for a cap badge on my "brass hat" and four rings of gold lace on a weather jacket. I think the ruse was successful, and I certainly was not recognized as the "padre". It was a change from the usual routine and, after it was over, the sub-lieutenant from the *Qu'Appelle* and myself became reconciled.

While all this was going on the ship had to be cleaned and the decks painted. This gave us more work. Not a dull moment. But it paid off when we were in Vancouver for the week-end of August 23 for the Pacific National Exhibition. We were alongside with the *Qu'Appelle* and the US Coastguard ship, *Gresham*. Several functions were held on board, and Saturday and Sunday afternoon were open to the public for visiting the ships. Then off again Mon-

day morning for the last week of the three-week work-up exercises.

The third week followed the pattern of the previous two weeks, with other exercises added, such as being attacked by divers, etc. All in all, as we leave, it is apparent that the exercises have been successful and the ship is ready for action. Also on board for two weeks were Cdr. Albert Holland, commanding officer, HMCS *Discovery*, Vancouver naval division, and several other reserve officers and men.

From a personal standpoint, the work-ups gave a picture of the wartime functions of the chaplain.

In the first place, the chaplains are in the services to attend to the spiritual, and often, the temporal needs of those in the service. There are many problems that exist when men are living away from their homes. This is particularly so in the Navy. Compassionate cases are often investigated by the chaplains. In wartime chaplains assist the wounded and the dying, get in touch with relatives, etc. There are many things they do that are of such a private nature that they are not known or mentioned publicly.

Actually, if clergy are needed at home, when people are living an ordinary normal life, then they are needed even more so in the services when the men are often living under abnormal stresses.

During the work-ups war-time conditions are simulated. The wounded are carried down to the sick bay where the chaplain is on duty, or else he may be in charge of the emergency sick bay in the wardroom. This is the work I have been doing, besides going through action stations and the other exercises with the rest of the ship's company.

Therefore, I feel the way the men feel, that while it was a busy time and could not have been continued much longer without the strain beginning to tell on some of us, it had been a job well done and HMCS *Saskatchewan* is now ready for war or any other emergency.

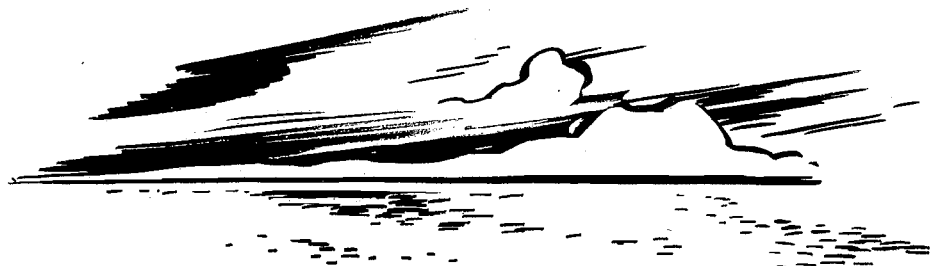

OFFICERS AND MEN

Ottawa Back In Service

Cdr. Jacques P. Côté took command of the destroyer escort HMCS *Ottawa* on her commissioning Oct. 28 at Esquimalt.

Since June 1963 the ship has been undergoing conversion at Victoria Machinery Depot so that she can operate an all-weather anti-submarine helicopter. She has also been fitted with variable sonar and underwent a thorough refit. The *Ottawa* is the third of seven St. Laurent class destroyer escorts to complete conversion.

Cdr. Côté was born in Quebec City and entered the former RCN College, HMCS *Royal Roads*, in 1942. He was appointed to Royal Navy ships for training as a midshipman and served in the battleship HMS *King George V* in Pacific operations in the last year of the Second World War.

He qualified as a naval pilot in 1947 and served in naval air squadrons at *Shearwater* and on board the aircraft carrier *Magnificent*. In 1952 he was appointed naval aide-de-camp to the Rt. Hon. Vincent Massey, then Governor-General of Canada.

In 1958 he began two years as executive officer of the destroyer escort *Restigouche*, after which he attended the RCAF Staff College, Toronto. A

Weddings

Sub-Lieutenant Peter F. Dorrington, *Kootenay*, to Joan Alayna Hennekan, of Monkton, Ont.

Able Seaman R. G. Jeffrey, *Saskatchewan*, to Lorna Simpson, of Victoria.

Able Seaman D. E. Jowsey, *Saskatchewan*, to Margaret Ann Murray, of Parksville, B.C.

Able Seaman T. D. Letki, *Saskatchewan*, to Karen Tripps, of Sarnia, Ont.

Sub-Lieutenant Ronald O'Donoghue, *Chippawa*, to Donna May DeMary, of Ottawa.

Able Seaman Frederick Maxwell Parlby, *Qu'Appelle*, to Diane Marie Conrad, of Halifax.

Births

To Sub-Lieutenant R. C. Waller, *Saskatchewan*, and Mrs. Waller, a daughter.

To Able Seaman R. W. Anderson, *Saskatchewan*, and Mrs. Anderson, a son.

To Ordinary Seaman W. R. Draper, *Saskatchewan*, and Mrs. Draper, a daughter.

To Able Seaman G. J. Leboutillier, *Saskatchewan*, and Mrs. Leboutillier, a daughter.

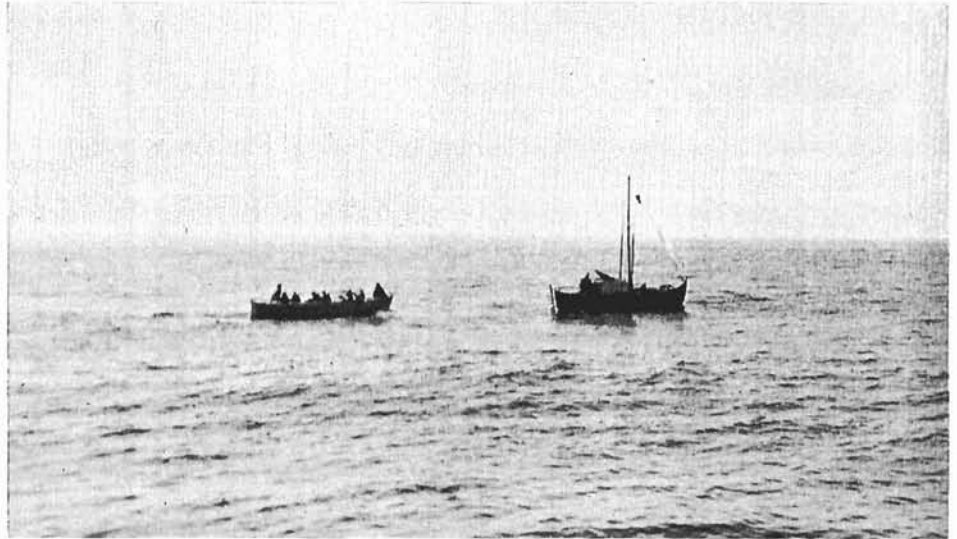

Even if land is only 45 miles away, the Pacific Ocean is a big, lonely place to anyone who has been without food for three days and has drunk the last of his water supply. Fisherman George McNamara, captain and crew of the disabled 26-foot *Goonebird*, out of Seattle, was more than pleased when HMCS *Saskatchewan* spotted his boat off the west coast of Vancouver Island on Oct. 20 and dispatched a seaboard to investigate. The fisherman was fed and provisioned and his vessel was towed to Bamfield, B.C., by HMCS *Mackenzie*.

period in Naval Headquarters preceded his appointment in February 1962 as Vice-Commandant and Officer Commanding Cadet Wing, at le Collège militaire royal de St-Jean, Que.

Scholarships For Three Cadets

Three junior officer cadets at the Canadian Services College, *Royal Roads*, have received \$400 Ontario Department of Education scholarships as a result of their standing in Grade 13 examinations.

They are RCN Officer Cadet Thomas Badenock, who studied at Woodroffe High School, Ottawa, Air Force Cadet Robin C. McNeill, who attended Ridgemont High School, Ottawa, and Army Cadet John E. Miller, who attended Kingston Collegiate and Vocational Institute, Kingston.

Cadet Badenock is the son of Major and Mrs. D. O. Badenock, of Ottawa. Major Badenock is serving at Canadian Forces Headquarters.

Cadet McNeill is the son of Group Captain and Mrs. C. W. McNeill, Washington, D.C. Group Captain McNeill, serving with the Royal Canadian Air Force, is assistant air attaché, Canadian Joint Staff, Washington.

Cadet Miller is the son of Captain and Mrs. J. E. Miller, Kingston. Captain Miller, serving with the Canadian Army, is camp commandant, headquarters, Eastern Ontario Area.

Housing Survey In Halifax Area

A thorough survey of the housing needs of married officers and men of the RCN's Atlantic Command residing in the Halifax-Dartmouth area was ordered in October by Rear-Admiral Jeffrey V. Brock, Flag Officer Atlantic Coast.

The survey includes a questionnaire to be completed by each married officer and man to determine types of accommodation now used, cost breakdown and other pertinent information.

From the information received, naval authorities, in conjunction with representatives from the Central Mortgage and Housing Corporation, will submit recommendations to Ottawa for consideration by federal authorities.

Rear-Admiral Brock ordered the survey following recent discussions with James Houston, regional supervisor of CMHC.

Earlier, the need for adequate housing was discussed with members of the

Commons Defence Committee during their visit to Halifax in July.

In September, Hon. J. R. Nicholson, Postmaster General and minister responsible for administering the National Housing Act, visited Halifax. Mr. Nicholson attended a meeting in the Maritime Headquarters building arranged by Rear-Admiral Brock, and was accompanied by John E. Lloyd and Gerald Regan, Members of Parliament for Halifax.

Also attending that meeting were Mr. Houston, D. R. Monk, assistant to Mr. Nicholson, and F. F. Field, director of the CMHC Information Division.

An estimated 7,000 married officers and men now reside in the area, with a "navy community" of about 33,000 including their wives and children.

The needs of these wives and children will be an important consideration in any recommendations to be made to Ottawa, Rear-Admiral Brock said.

Captain Ryan Shearwater CO

Captain D. H. Patrick Ryan was appointed commanding officer of HMCS *Shearwater*, RCN air station, and at the same time promoted to his present rank on Nov. 9.

He had been commanding officer of HMCS *Kootenay*, destroyer escort of the Fifth Canadian Escort Squadron at Halifax.

Captain Ryan succeeds Commodore G. C. Edwards who has taken up the appointment of Commodore Personnel Atlantic Coast, at Halifax.

Captain Ryan was born in Montreal on Aug. 29, 1923, and served in the Canadian Army before entering the former RCNVR in 1941 as a probationary midshipman.

He served in the corvette *Matapedia* and in 1944 began the flying training in Canada which preceded his service in Royal Navy and later RCN fighter squadrons. He commanded Fighter Squadron 871, based at *Shearwater*, in 1950-52.

He later was executive officer of the destroyer escort *St. Laurent* and held various staff appointments at Naval Headquarters in Ottawa and at the Canadian Joint Staff, Washington. He took command of the *Kootenay* in 1962.

Deputy SACLANT Visits Ottawa

Vice-Admiral I. W. T. Beloe, Deputy Supreme Allied Commander Atlantic, visited Ottawa November 11-13 to confer with the Minister and Associate Minister of National Defence and officials at Canadian Forces Headquarters.



Two members of the staff of the Flag Officer Atlantic Coast assisted at social functions attended by Her Majesty in Charlottetown. They are PO George Skelton and AB John R. Gorman. Two others, PO D. E. Hoppe, of HMCS *St. Laurent*, and PO D. J. Richardson, of the Yukon, also assisted at functions in honour of Her Majesty. (HS-76323)

Admiral Beloe arrived at RCAF Station Uplands Wednesday, Nov. 11, where he was met by Vice-Admiral K. L. Dyer, Chief of Personnel.

Before becoming Deputy Supreme Allied Commander Atlantic a year ago, Admiral Beloe served as Flag Officer Medway and Admiral Superintendent of Her Majesty's Dockyard, Chatham, England. He joined the Royal Navy in 1923 and was promoted to his present rank of vice-admiral in May 1963.

25-Year Pins Presented

Three civil servants on the staff of the Director General of Naval Supply were presented with 25-year pins and certificates of appreciation at a single ceremony in October.

The presentations, made by Captain D. A. Collins, DGNS, were to Mrs. M. J. Hazelton, J. C. Joly, and C. G. Donnelly.

HELP, SYMPATHY APPRECIATED

A letter has been received from Mrs. Audrey M. Godbout, of Arvida, Que., conveying the gratitude of the brothers and sisters of the late PO Russell Scott George, of HMCS *New Waterford*, to his many friends in the RCN for their assistance and expressions of sympathy at the time of his death.

PO George died of natural causes on Oct. 14 in the Canadian Forces Hospital, Halifax, and was buried at sea from HMCS *Inch Arran*. His sister, Mrs. Godbout, had been designated his next of kin.

Mrs. Hazelton, a principal clerk, entered the Civil Service in the Department of Finance in September 1930. She transferred to the Department of Agriculture in November 1939 and to National Defence (Navy) the following March. She has been with DGNS since 1957.

Mr. Joly, also a principal clerk, entered the Civil Service as a post office department employee in 1939. He has been associated with naval supply since 1941.

Mr. Donnelly, a technician, grade 3, was briefly with the office of the Secretary of State before transferring to the Department of National Defence (Navy) in November 1939.

He was commissioned in the RCN in 1943 and was demobilized with the rank of lieutenant in 1947, returning to the employment with the Director of Naval Stores. He has been with the Director General Naval Supply since 1953.

New Captains For Two Ships

Lt.-Cdr. Keith M. Young has taken command of the ocean escort *Ste. Therese*, of the Fourth Canadian Escort Squadron, based at Esquimalt.

He formerly commanded the *Beacon Hill*, of the same squadron, where he has been succeeded by Lt.-Cdr. William Andrew Hughes.

Before becoming captain of the *Beacon Hill*, Lt.-Cdr. Hughes was Staff Officer (Torpedo Anti-Submarine) to the Naval Member Canadian Joint Staff, London, England.

Credit Unions Supported

The Royal Canadian Navy described credit unions as providing "a worthwhile service to personnel" in a recent directive which outlines their benefits and the place they should have in naval establishments.

Naval General Order 2.00/44 points out that credit unions operating in Department of National Defence establishments are private enterprises, and the RCN cannot participate officially in their formation or operation, but commanding officers are encouraged "to assist in their promotion". The approval of Canadian Forces Headquarters must be obtained, however, before any new credit union is organized.

The provision of suitable office space if available for credit unions, is authorized "on a recoverable basis", with credit unions to provide their own furniture and equipment. The order also encourages service personnel and civil-

ian employees of the DND to participate in credit union operations outside working hours.

The credit union directive notes that personnel may make assignments of pay to a credit union. Such pay assignments were authorized for all members of the armed forces in 1955.

A similar endorsement of credit unions was issued by the Royal Canadian Air Force in February 1963.

Canadian armed forces personnel and civilian employees of the DND now directly own and operate some 25 credit unions, with assets totalling \$10 million, and they are associated with other federal government employees or small community groups in the operation of almost another 100. An added benefit is that they can keep their credit union membership and pay assignments no matter where they are posted.

Red Cross Gives Thanks for Aid

At the annual meeting of the Nova Scotia division of the Canadian Red Cross Society, a resolution expressing the appreciation and thanks of the society to the Royal Canadian Navy for its assistance in blood donor clinics and other activities of the Red Cross was passed unanimously.

In conveying the resolution to Rear-Admiral J. V. Brock, then Flag Officer Atlantic Coast, C. L. Illsley, commissioner of the Nova Scotia division of the Red Cross, said:

"In the past year we have had the utmost co-operation from the officers



Congratulations on its 22nd anniversary as a service college are expressed by His honour, Judge J. B. Clearihue, Chancellor of the University of Victoria, during a mess dinner held on Trafalgar Day, Oct. 21, at the Canadian Services College, Royal Roads. Royal Roads, which now trains officer cadets of all three services, was opened officially as a naval college on Oct. 21, 1942, by Hon. Angus L. McDonald, Canada's war-time Minister of National Defence for Naval Services. (RR-3502)

WREN OFFICERS JOIN EASTER ISLAND CRUISE

TWO WREN OFFICERS have a share in the Easter Island medical expedition which sailed from Halifax on Monday, Nov. 16. It marks the first time in the history of the RCN that service women have taken a cruise of any duration in one of the Navy's ships.

Lt. Mary Olive King, of Hampton, N.B., and Halifax, who has a scientific background, and Lt. Rita Catherine Dwyer, of Toronto and Ottawa, a Spanish linguist, have been appointed to HMCS *Cape Scott*, mobile repair ship that is taking a team of 33 scientists to Easter Island. The purpose of the expedition is to conduct a large-scale study of the 1,005 inhabitants of the remote island, a Chilean possession in the southeastern Pacific, visited only once a year by a Chilean naval supply ship.

Lt. King, who was a wren officer in the Second World War, was a statistician at Atomic Energy of Canada, Chalk

River, before entering the wrens again in 1961. In her spare times she runs the planetarium of the Nova Scotia Museum in Halifax and lectures on astronomy. She serves normally at HMCS *Stadacona*, Halifax.

Lt. Dwyer, also a wartime wren, worked in the Department of External Affairs for 10 years before rejoining the wrens in 1959. A Spanish linguist, she had one External Affairs tour in the Argentine. She has been serving in Canadian Forces Headquarters, Ottawa.

The *Cape Scott* will bring the expedition back to Halifax on March 17.

A third naval officer is also to be attached to the team. He is Surgeon Captain R. H. Roberts, Chief of Medicine, Canadian Forces Hospital, Halifax, who will be in charge of medical examinations. His wife, Professor Maureen Roberts of Dalhousie University in Halifax, will supervise genetic studies.

and men under your command, in connection with our blood donor clinic, the water safety program of the society and through financial support . . .

"On our part, we tried to keep the many programs of the society up to a high standard, serving all citizens and our armed forces.

"On this occasion we would make special mention of your personal interest and kind co-operation in our endeavours, and recognize that your personal awareness of our problems ensured the high level of response continually received from personnel of your command, and we extend every good wish to you on your departure."

New Captain For Crescent

Cdr. H. Charles Larose was appointed in command of the Halifax-based destroyer escort *Crescent* on Oct. 23.

Since 1961 he has served at HMCS *Cornwallis* at first as officer-in-charge of new entry training and later in the dual appointments of executive officer and training commander of the establishment.

Cdr. Larose was born on March 17, 1918, in Waterloo, and, after graduating in law from the University of Montreal, entered the former RCNVR in June 1942. He transferred to the regular force in 1947.

He has commanded the coastal escort *New Liskeard* and the frigate *Fort Erie*.

Promotion for Petty Officer

PO Ronald F. Pollard has been promoted to the rank of commissioned officer in the Royal Canadian Navy.

Cdr. Off. Pollard has been serving in the Halifax-based destroyer escort *Algonquin* as an engineering technician. Born in Berwick on June 18, 1931, he was living in Verdun, Que., when he joined the Navy in October 1951, as an ordinary seaman.

He has served ashore on both coasts and in the cruiser *Ontario*, destroyer *Sioux*, ocean escort *Stettler* and repair ship *Cape Breton*. Following courses ashore, Cd. Off. Pollard will join the aircraft carrier *Bonaventure* in December.

Seven Aircrew Complete Course

Seven naval aircrewman have graduated from a 23-week course for their trade in the Fleet Air School at HMCS *Shearwater*.

After a short period of leave they will join VS-880, anti-submarine squadron, for one year of on-the-job training and operational flying.

The graduates are Able Seaman C. D. Waddell, R. S. Wach, E. J. Procher, K. B. Ramsdale, H. D. Oke, W. J. Rudy, and B. H. Weatherley.

The course officer was Lt. C. R. Thoms and course petty officer PO C. G. Moore.

COAST COMMANDS CHANGE



REAR-ADMIRAL
M. G. STIRLING
New FOPC

REAR-ADMIRAL
JEFFRY V. BROCK
Retired

REAR-ADMIRAL
W. M. LANDYMORE
New FOAC

REAR-ADMIRAL J. V. Brock, DSO, DSC, CD, Flag Officer Atlantic Coast and Maritime Commander Atlantic, retired from the Royal Canadian Navy in mid-November after more than 30 years of distinguished service.

He was succeeded at Halifax by Rear-Admiral W. M. Landymore, OBE, CD, previously Flag Officer Pacific Coast and Maritime Commander Pacific, with Headquarters at Esquimalt. Rear-Admiral M. G. Stirling, CD, who had been serving as Chief of Naval Personnel was appointed to succeed Admiral Landymore.

REAR-ADMIRAL JEFFRY VANSTONE BROCK, DSO, DSC, CD, RCN

Rear-Admiral Jeffrey Vanstone Brock was born in Vancouver on Aug. 29, 1913. He later lived in Winnipeg, where he attended St. John's College School and the University of Manitoba.

He entered the former Royal Canadian Naval Volunteer Reserve there in 1934 and became executive officer of the Winnipeg division before returning to B.C. to become commanding officer of the RCNVR Divisional Headquarters at Vancouver.

At the outbreak of the Second World War, Admiral Brock became signals officer at Esquimalt. Early in 1940 he went overseas and began a four-year period of service on loan to the Royal Navy.

During this time he commanded several anti-submarine vessels, including

a trawler, two corvettes and a destroyer escort. Before returning to Canada in 1944, he held the appointment of Senior Officer of a Royal Navy escort group, the first time a Canadian in the RCNVR had served in such a capacity.

On his return to Canada, he became the first RCNVR officer to command a Canadian escort group.

Among the highlights of Admiral Brock's career at sea during the war was an encounter with a pack of more than 20 U-boats in October 1943. The escort group destroyed six of the submarines and drove off the remainder in a prolonged battle. On another occasion a ship he commanded was credited with sinking a submarine.

Admiral Brock was awarded the Distinguished Service Cross in June, 1945, "for outstanding service in anti U-boat operations during the war in Europe". Earlier he was mentioned in despatches for good service in attacks on enemy submarines.

In March 1946 he transferred to the regular force and was appointed to HMCS *Ontario* (cruiser) as executive officer when she commissioned in mid-1947.

Later he attended a course at the RCAF Staff College, Toronto, following which he was appointed Director of Naval Plans and Operations at Headquarters. He was subsequently promoted to the rank of captain.

Admiral Brock was appointed in command of HMCS *Cayuga* (destroyer)

with the additional appointment of Commander Canadian Destroyers Pacific in July 1950 and joined the United Nations fleet in the Far East.

During his service in Korean waters, Admiral Brock on several occasions had ships of other UN navies placed under his command for specific operations. In the Inchon invasion of September 1950 he commanded a United Nations force protecting a flank of the invasion area. In December he led a UN destroyer group into the port of Chinnampo to cover the evacuation of 7,000 personnel and to destroy harbour installations in the face of approaching enemy forces.

For his service in the Korean theatre he was awarded the Distinguished Service Order and was mentioned in despatches.

In August 1951 he was appointed naval member of the directing staff of the National Defence College, Kingston, and in September 1953 he became Naval Member, Canadian Joint Staff, London, Naval Member of the Military Agency for Standardization, and Commanding Officer, HMCS *Niobe*, London. He was promoted to commodore in January 1957. In June of that year, he returned to sea as Senior Canadian Officer Afloat Atlantic.

Admiral Brock took up the appointment of Assistant Chief of the Naval Staff (Air and Warfare) in July 1958. He was promoted to rear-admiral and appointed Vice-Chief of the Naval Staff and Member of the Naval Board in

June 1961. He became Flag Officer Atlantic Coast, Maritime Commander Atlantic and Commander Atlantic Sub Area of NATO, with headquarters at Halifax, N.S., in July 1963.

REAR-ADMIRAL WILLIAM MOSS LANDYMORE, OBE, CD, RCN

Rear-Admiral William Moss Landymore, was born in Brantford, Ont., on July 31, 1916, and entered the Royal Canadian Navy as a cadet in August 1936. He took his early training in ships and establishments of the Royal Navy.

Following the outbreak of war, he served in the destroyer HMCS *Fraser* until June, 1940, when the ship was lost in a collision during the evacuation of France. His next ship was HMCS *Restigouche* in which he served only a short time before being appointed to a third destroyer, HMCS *Margaree*, in September 1940. He was in the latter ship only six weeks, when she, too, was sunk in a collision in the North Atlantic.

Rear-Admiral Landymore spent the next 18 months ashore, then went to the United Kingdom for a gunnery course. While overseas he served in the cruiser HMS *Belfast* and the destroyer HMS *Grenville* from May to November 1943. In June 1944 he was appointed to another cruiser, HMS *Uganda*, which was later transferred to the RCN and served in the war in the Pacific.

After more than two years in the *Uganda*, he became Staff Gunnery Officer with the Director of Weapons and Tactics at Naval Headquarters, Ottawa and, remained in this post until September 1948. He then attended staff tactical courses.

In January 1950 Rear-Admiral Landymore was appointed Director of Manning and Personnel Statistics at Naval Headquarters.

In October 1951 he took command of the destroyer escort HMCS *Iroquois*, making two tours of duty with the United Nations fleet in Korean waters. He also held the appointment of Commander, Canadian Destroyers, Far East. He was mentioned in despatches during the first tour and awarded the OBE following the second. In 1954 Rear-Admiral Landymore attended the Imperial Defence College at Camberley, England, and, in January 1955, he was appointed Director of Naval Plans and Operations at Headquarters.

He took command of the aircraft carrier *Bonaventure* in January 1958 and became Chief of Staff of the Flag Officer Atlantic Coast in October 1959.

He was appointed Senior Canadian Officer Afloat, Atlantic in September 1962.

Rear-Admiral Landymore took up his appointment as Flag Officer, Pacific Coast and as Maritime Commander Pacific on November 1, 1962, and was promoted to his present rank on that date.

REAR-ADMIRAL MICHAEL GROTE STIRLING, CD, RCN

Rear-Admiral Michael Grote Stirling was born in Kelowna, B.C., on June 29, 1915, and entered the Navy as a cadet in 1933. He trained in ships and establishments of the Royal Navy until 1938, when he joined the Canadian destroyer *Skeena* on the Pacific Coast.

Later that year he transferred to HMCS *St. Laurent* (destroyer). In April 1940 Admiral Stirling became executive officer of another destroyer, HMCS *Assiniboine*, and that November began a specialist communications course in England.

After signals duties with a British destroyer flotilla, he returned to Canada in May 1942 to be Deputy Director, Signals Division, Naval Headquarters, Ottawa. Sixteen months later he became staff signals officer to the Commander-in-Chief, Canadian Northwest Atlantic, at Halifax.

Admiral Stirling returned to the *St. Laurent* as commanding officer in November 1944, but a year later transferred his command to the newly-commissioned destroyer *Crusader*, where he served until early 1946.

For the next 16 months he held shore appointments on each coast and in Ottawa. After a brief period in com-

mand of the destroyer *Nootka*, Admiral Stirling went to Washington, D.C., in December 1947 to serve on the staff of the Naval Member, Canadian Joint Staff.

Back in Ottawa in April 1949 he became Director of Naval Communications.

Admiral Stirling was appointed executive officer of the training cruiser *Ontario* in September 1951, which was followed in January 1953 by his attachment to the headquarters in Norfolk, Va., of the Supreme Allied Commander, Atlantic. He was promoted to captain that same month.

Admiral Stirling assumed command of HMCS *Cornwallis*, the new entry training establishment near Digby, N.S., on January 24, 1955, with the additional appointment as Officer-in-Charge, New Entry Training, on the staff of the Flag Officer Atlantic Coast.

Admiral Stirling took command of HMCS *Crescent* (destroyer escort) in March 1957, with the additional appointment of Commander Second Canadian Escort Squadron and Senior Officer in command. He was appointed Naval Member of the Directing Staff of the National Defence College at Kingston in July 1958. In June 1959 he was promoted to the rank of commodore.

He took up the appointment of Senior Canadian Officer Afloat (Atlantic) on September 18, 1961. He was appointed Chief of Naval Personnel and a member of the Naval Board in September 1962. At that time he was promoted to rear-admiral.



The Canadian Services College, Royal Roads, was one of the calls made by the RCAF's Senior Protestant Chaplain in early October. Group Captain E. A. Light, left, talks with Captain W. P. Hayes, RCN, Commandant of Royal Roads, centre, and W/C L. Spruston, RCAF, Vice-Commandant. (RR-3441)

HELPING CHILDREN

SAILORS, in their travels about the world, know the straits in which so many of the children of other lands find themselves—starving, sick, poorly clothed and desperately in need of protection and assistance.

For this reason, it has almost become commonplace for ships' companies, looking for a worthwhile place to spend accumulated canteen profits, to turn to services which seek to help suffering and impoverished children.

There are a number of organizations whose efforts are devoted wholly or largely to the alleviation of distress among the world's children. Among these are the United Nations International Children's Emergency Fund, which supplements its funds through Hallow'e'en donations and Christmas card sales, the Unitarian Service Committee, CARE and, more specifically where individual children are concerned, the Save the Children Fund and the Foster Parents' Plan.

Ships and shore establishments of the RCN have on many occasions "adopted" children under the two last named plans, sending money and gifts with a view to feeding, clothing and educating their young charges and providing them with something more than the barest necessities of life.

At the moment, three ships of the RCN are sponsoring children under the Save the Children Fund and a recent communication from the B.C. branch of the Funds tells of the origin and objectives of the organization. As a matter of naval interest, the B.C. branch has as its president Lt.-Cdr. Cornelius Burke, DSC and Two Bars, RCNR (Ret), who had a stirring naval career as a commander of HM gunboats in the Mediterranean and Adriatic during the Second World War.

The Save the Children Fund came into existence after the First World War to help needy children, without regard to country, colour or creed. It now ranks as one of the largest voluntary agencies in the world, with Commonwealth branches and with doctors, nurses and welfare workers stationed in some 21 countries in Europe, the Middle East, Africa and the Far East. Children are helped by food distribution, medical attention, education, etc., and instruction is given to the people of the countries

concerned so that they can eventually carry on the work started by the fund.

One of the most appealing ways of helping children through the fund is to sponsor or "adopt" a child from a needy area. The fund supplies such donors with history sheets and photos of "their children and encourages an exchange of letters. This often results in the children receiving special parcels from the

sponsors in addition to the regular grant paid through the local Save the Children Fund office every three months. It costs \$50 a year to sponsor a child. This is payable in a lump sum or semi-annually or quarterly. The sponsorship plan applies to France, Austria, Yugoslavia, Malta, Italy, Greece, Lebanon, Morocco, Uganda, Pakistan, Hong Kong and Korea.



A "Wavy Navy" officer, who won the Distinguished Service Cross and two bars while commanding British gunboats in the Mediterranean and Adriatic during the Second World War, Lt.-Cdr. Cornelius Burke, RCNR (Ret), of Vancouver, is president of the British Columbia branch of The Save the Children Fund. Lt.-Cdr. Burke figured prominently in the book "MGB 658". He is shown here with Sybil Conery, executive secretary of the B.C. branch of the Fund, and (right) Mrs. Burke. The Save the Children Fund provides an avenue through which ships' companies can and do extend help to needy children of the world.

It is more than five years now since HMCS *Terra Nova*, then newly commissioned on the West Coast, sponsored a 10-year-old French boy, Bernard Bozec, whose father, a fisherman, had been lost at sea and whose widowed mother worked in a herring cannery in a small Brittany village. The money provided by the sponsorship was used to help with Bernard's food and clothing. In July 1960 two sailors from the *Terra Nova* visited him and this year, when the ship visited a French port, Bernard and his mother were invited on board. The two events were reported in the Christmas 1960 and March-April 1964 issues of *The Crow'snest*.

The next ship to participate in the fund's work was HMCS *Sussexvale*, Pacific Command ocean escort, whose ship's company undertook the sponsorship of an eight-year-old Italian girl, Angelica Ficca, who lives in the province of Chieta, not far from the still-ruined town of Ortona, well known to Canadian soldiers of the last war. The father of this family has no cash income, working in the fields of landowners for payment in kind, such as wheat, flour and firewood.



A small boy in Pusan, Korea, must beg to survive.

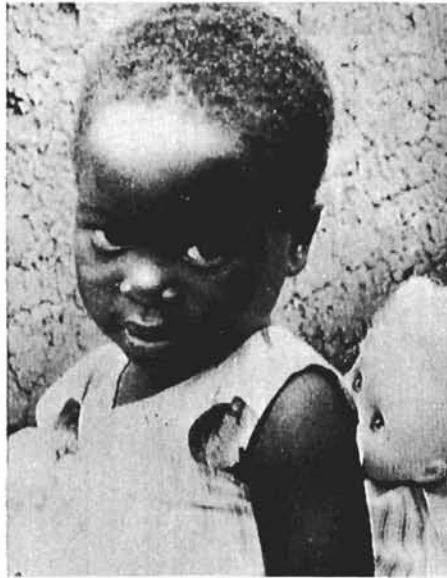

A little Uganda maid mothers the blonde doll sent by a western sponsor.

The family's home is a miserable, tiny two rooms in the poorest area. The quarterly sponsorship payments help with food and clothing and give the family some sense of security.

The men of the *Sussexvale* write to Angelica and recently sent a picture, signed by all the godfathers, of their ship passing under the Lion's Gate bridge at Vancouver. Letters of thanks were received from Angelica who said she had shown the picture to all the villagers. She hopes some day to have a visit from her *Sussexvale* friends.

Clothing Sent to Cyprus Children

Crippled children in strife-torn Cyprus will benefit from co-operation between the three armed services of the Victoria area.

In answer to an appeal from the Red Cross Crippled Children's Hospital in Nicosia, servicemen of the Pacific Command donated more than 1,000 pounds of children's clothing in a concentrated drive directed jointly by Lt.-Col. Douglas Nelson, of 25 Militia Group Headquarters, and RCN Protestant Chaplain Andrew Mowatt.

Clothing was loaded into an RCAF Dakota at Patricia Bay airport on the morning of Nov. 10 for the first of the flight to Cyprus, via Trenton, Ont.

Canadians had reason to be proud last spring when HMCS *Athabaskan* rescued 34 merchant seamen from the Liberian tanker *Amphialos*, which had broken in two in the stormy North Atlantic. Their pride could not match that of little Angelo Bongarra and his sister Stellina, residents of a poverty-stricken village in Sicily, when they heard the story.

In the summer of 1961 the men of the *Athabaskan* arranged to sponsor Angelo but when the history sheet arrived and the distress of the family became known they also undertook to "adopt" his small sister Stellina ("Little Star"). The mother had a nervous breakdown after another of the children died, the father died of cancer of the throat and the care of Angelo and Stellina fell to an 11-year-old sister.

The whole ship's company of the *Athabaskan* sees the letters written by the children and, in return, the sailors send answers, parcels and encouragement. It is small wonder that the most fervent wish expressed by the youngsters is to see their Canadian godfathers.

The address of the B.C. branch of the Save the Children Fund through which these ships arranged their sponsorship is Suite 9, 2775 West Broadway, Vancouver 9, B.C.



New shoes were a desperate need of this Italian child.



TROOP CONVOY

*How Canada Went
to War in 1914*

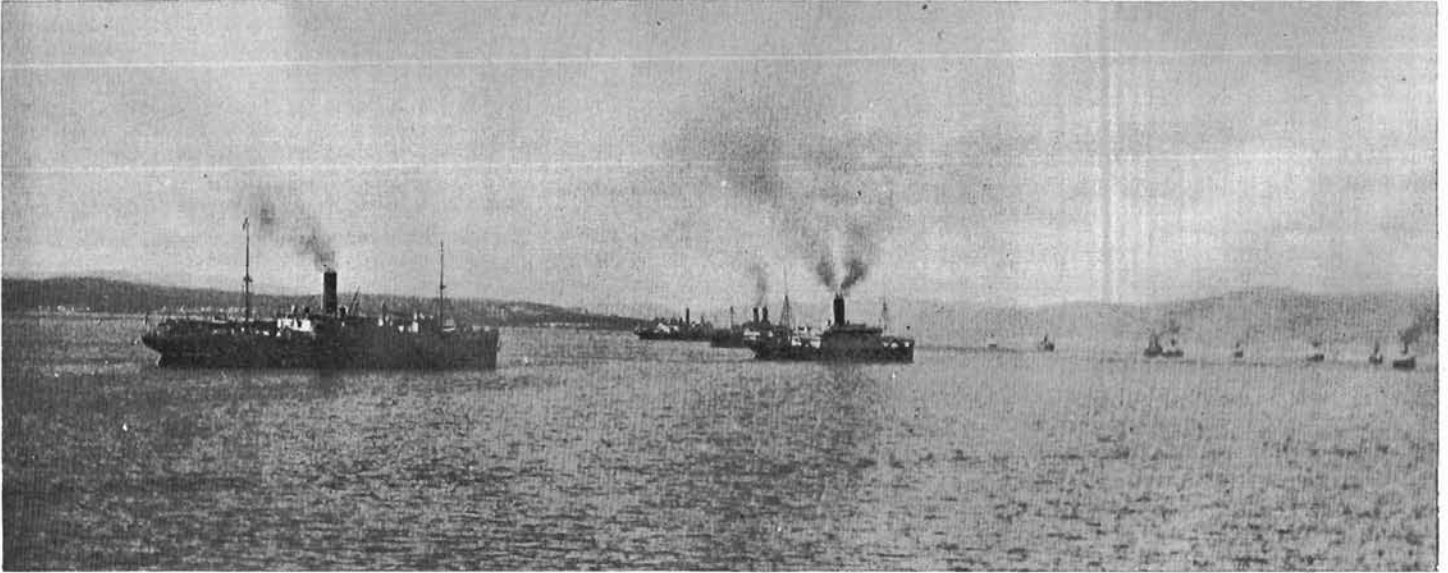

The transports assembled in Gaspé Bay awaiting passage. (CN-6835)

FFIFTY YEARS ago the Royal Canadian Navy, then only four years old, went to war for the first time. Its beginnings had not been auspicious and it could hardly be regarded as a force to be reckoned with.

But, small as it was, the infant RCN prepared for battle with determination and bravery. Fate decided that four young midshipmen of the RCN should be among the first to die for Canada in that world conflict.

A naval event—the sailing of the first troop convoy from Canada, escorted by ships of the Royal Navy—took place at the beginning of October 1914. A month later the Battle of Coronel was fought off the coast of Chile when the Royal Navy suffered its first defeat in more than 100 years. Four Canadian midshipmen were serving in the flagship of the British squadron, HMS *Good Hope*, which was lost with all hands.

The four, all of whom were members of the first class at the Royal Navy College of Canada when it opened in Halifax in 1910, were William Archibald Palmer, John Victor Whiteman Hatheway, Arthur Wiltshire Silver and Malcolm Cann.

The opening days of the First World War were recalled in an address to the Red Chevron Club of Ottawa on Oct. 10 by Rear-Admiral Hugh F. Pullen, who was Flag Officer Atlantic Coast at the time of his retirement in 1960.

The Red Chevron Club numbers among its members those Canadians who went overseas with the First Contingent of 32,000 men in the first convoy of the First World War in October 1914. Members of the First Contingent were given a red chevron as sleeve insignia; all subsequent chevrons for each year of service were blue.

Apart from the Canadians who went to South Africa, the sailing of the First Contingent was the first major step taken by Canada overseas, Admiral Pullen said. In fact it can be considered as the first step on the road that has led to the establishment of a true Canadian identity, to Canada as a nation, and to the formation of the Commonwealth.

The text of Admiral Pullen's address follows:

The problem of getting the First Contingent to England was a naval one, and of the kind that the navy has had to deal with for centuries. It consisted of transporting, in safety, a large number of soldiers with all their stores and equipment, across the North Atlantic. The troop ships required an escort of men of war to defend them against attack from surface ships and submarines.

The whole idea of convoy goes back at least to the 13th Century. We know that Henry III in 1226 ordered all shipping to be sailed in convoy, and this included merchant ships as well as

troop transports. This method or system of moving forces across the sea in war has been used ever since, and certainly when the enemy is capable of disputing the passage of the ships. When this well established principle is forgotten, the result is disastrous. Such was the case with merchant shipping from 1914 to 1917 before convoys were introduced. Between August 1914 and December 1917 over 10 million tons of Allied shipping was sunk, and for the entire war 4,837 merchant ships, representing 11,135,000 gross tons, were lost due to attack by submarine. This is a monthly average of 95 ships.

If merchant ships were to survive they simply had to sail in convoy. Despite many objections, this was done. The results were all in our favour. Sinkings dropped to a very small figure, and the war was won.

If sinkings had continued at the April 1917 rate of nearly four a day nothing could have prevented a German victory. Once again the lessons of history had been disregarded or forgotten, and in the process of relearning some old and established lessons, a fearful price in lives, ships and cargoes was paid.

ARRANGEMENTS for the transportation of the First Contingent were started on Aug 15 when the Minister of Militia (Sir Sam Hughes) held a meet-

ing with the representatives of the larger shipping companies. Ships were needed to carry some 25,000 men across the North Atlantic, sailing about the middle of September. Contracts were signed for 20 ships by September 11. This number was increased to 30 when it was decided to send the entire force that had been assembled at Valcartier. The merchant ships were prepared for their troopship role at Montreal, and as soon as they were ready they proceeded down the river to Quebec to embark their troops.

From what I have been able to find out, the embarkation of men, horses, guns, stores and equipment at Quebec was carried out with difficulty. A plan had been drawn up, but it was discarded due to delays in the arrival of the troop ships, changes in the number to be embarked, to say nothing of the interference of the Minister of Militia. As one officer described it, "chaos reigned supreme". I do not think one should be overly critical when it is remembered that an unmilitary nation had raised a force of nearly 30,000 fighting men in

about six weeks, and was sending it overseas. Many lessons were learnt by many people concerned with the movement of fighting men across the sea, and on the whole, they were not forgotten in 1939.

Only three ships were loaded according to the plan drawn up by the Director of Supplies and Transport. Then the Minister interfered, and the plan collapsed.

Embarkation began on Sept. 23, when the mounted units marched to Quebec. The infantry went by rail. The last ship was loaded and sailed at 5 pm Thursday, Oct. 1. In a few cases one unit complete in all respects was on board the same ship. One unit had to disembark due to lack of accommodation; some ships had to load ballast to give them stability, and in the end an extra ship had to be found to embark the men, horses and stores that had been left behind.

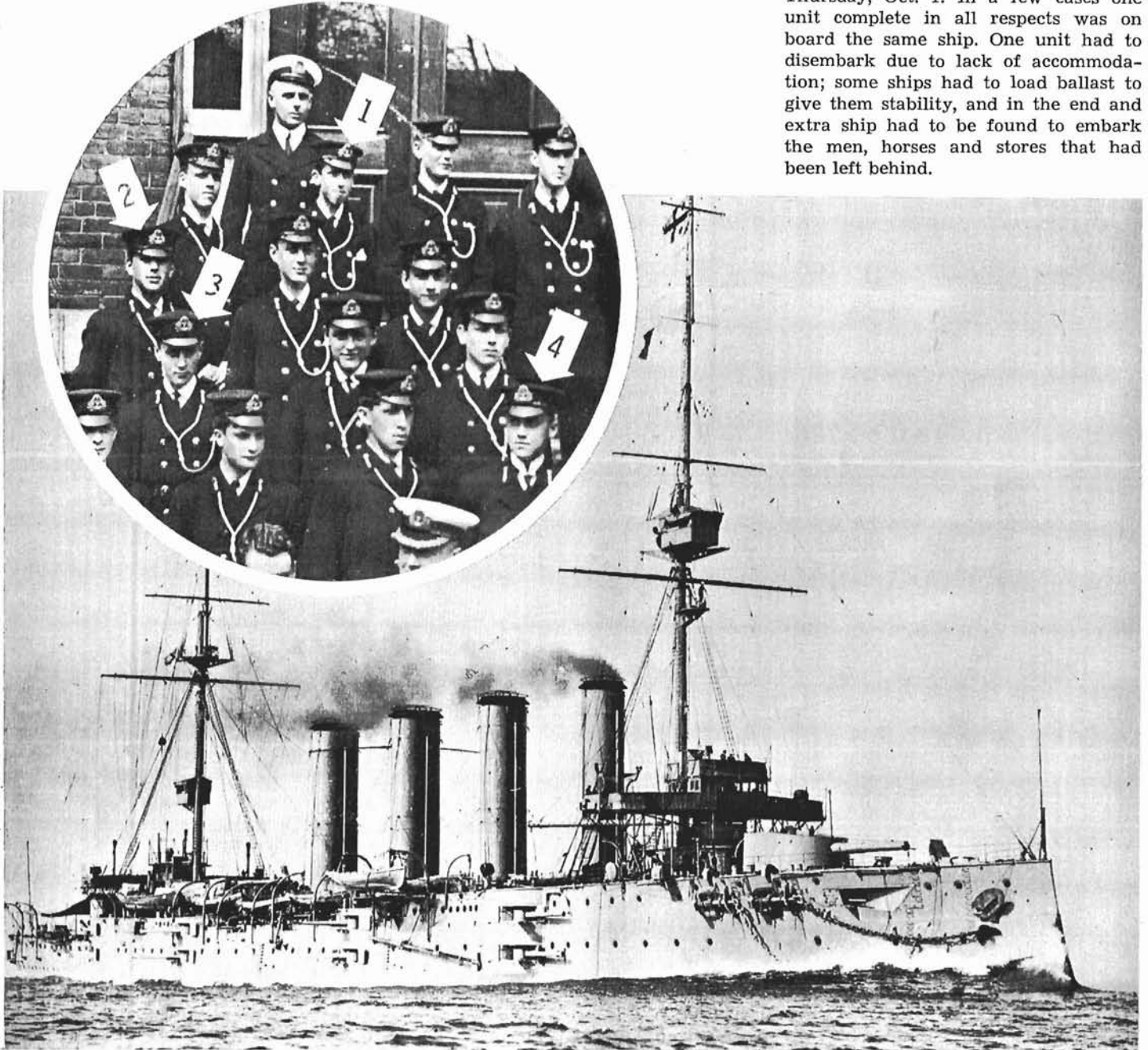

By the time the vanguard of the Canadian Army went into action in France in January 1915, the young Royal Canadian Navy had suffered its first casualties—four midshipmen lost when HMS Good Hope went down with all hands at the Battle of Coronel on Nov. 1, 1914. The four are shown in the inset as follows: 1. William Archibald Palmer; 2. John Victor Whiteman Hatheway; 3. Malcolm Cann, and 4. Arthur Wiltshire Silver.

The total figures for the First Contingent are well worth remembering: 1,547 officers, 29,070 men, 7,679 horses, 70 guns, 110 motor vehicles, 705 horsed vehicles and 82 bicycles—a most impressive force for any small nation to raise in less than two months. They were all volunteers and worthy representatives of Canada. I trust that the spirit that inspired them still burns in their grandsons.

As each ship was loaded, she went out into the river and anchored. There the Master was given his sealed orders. The first directed him to proceed down the river. The second, which was to be opened after the pilot had been dropped at Father Point, instructed him to proceed to an anchorage in Gaspé Bay. This would be given to him by CGS *Canada* which was carrying out a patrol off the entrance to the bay. The third was a message from the Governor General (HRH the Duke of Connaught) which was to be read to the troops:

"On the eve of your departure from Canada I wish to congratulate you on having the privilege of taking part, with the other forces of the Crown, in fighting for the Honour of the King and Empire.

You have nobly responded to the call of duty, and Canada will know how to appreciate the patriotic spirit that animates you.

I have complete confidence that you will do your duty, and that Canada will have every reason to be proud of you.

You leave these shores with the knowledge that all Canadian hearts beat for you, and that our prayers and best wishes will ever attend you. May God bless you and bring you back victorious.

ARTHUR, F. M.

Governor General of Canada"

The Minister had asked the Department of Marine and Fisheries and the Department of the Naval Service "to make sure that every possible precaution be taken to detect and prevent the laying of mines in the river or on the route to England." As there was no minesweeping gear of any sort, this request was quite impractical. All that could be done was that a good lookout be kept.

ON THE 30 transports reaching their anchorages in Gaspé Bay safely, they were ordered to be darkened at night and W/T silence was to be observed. Some form of security was instituted, but in general, as it affected the sailing of the First Contingent, it was not good.

As the troop ships arrived in Gaspé Bay they were anchored in the positions they would hold in the convoy on sailing. They were in three columns, Z, Y and X as follows:

Z	Y	X
<i>Megantic</i>	<i>Caribbean</i>	<i>Scotian</i>
<i>Ruthenia</i>	<i>Athenia</i>	<i>Arcadian</i>
<i>Bermudian</i>	<i>Royal Edward</i>	<i>Zeeland</i>
<i>Alaunia</i>	<i>Franconia</i>	<i>Corinthian</i>
<i>Ivernia</i>	<i>Canada</i>	<i>Virginian</i>
<i>Scandinavian</i>	<i>Monmouth</i>	<i>Andania</i>
<i>Sicilian</i>	<i>Manitou</i>	<i>Saxonia</i>
<i>Montezuma</i>	<i>Tyrolia</i>	<i>Grampian</i>
<i>Lapland</i>	<i>Tunisian</i>	<i>Lakonia</i>
<i>Cassandra</i>	<i>Laurentic</i>	<i>Montreal</i>
		<i>Royal George</i>

On joining the convoy off Cape Race, the *Florizel* with the Newfoundland Contingent on board, took station astern of the *Cassandra*. The *Manhattan* which had the "Stragglers" proceeded independently.

The Minister had been greatly concerned about the safety of the convoy, but was reassured when the Admiralty informed him that the escort would consist of four cruisers, HMCS *Niobe*, and a battleship, HMS *Glory*. A second battleship would join during the passage across the Atlantic.

There were three possible threats to the convoy. Firstly, it had to be covered against attack from heavy units of the High Seas Fleet, e.g., a battle cruiser or a cruiser might break out and get among the troop ships. (A good example of what might have happened is to be found in the attack on Convoy HX-84 by the *Admiral Scheer* on Nov. 5, 1940, when Captain Fegen in HMS *Jervis Bay* was the sole escort for 37 merchant ships). Another threat was the presence in New York and Boston of 14 German liners that could be fitted out as raiders. Finally it was known that SMS *Karlsruhe* was somewhere in the Atlantic. The Grand Fleet was quite capable of looking after the threat posed by the High Seas Fleet, and any breakout that might take place. The naval forces in the Western Atlantic were able to take care of the other two possibilities.

Rear-Admiral Phipps-Hornby was in command of the North American Squadron with his flag in the battleship HMS *Glory*. The other ships in the Squadron were HM Ships *Suffolk*, *Essex*, *Lancaster*, and *Caronia* (AMC) and HMCS *Niobe*. Rear-Admiral Wemyss, in command of the 12th Cruiser Squadron, HM Ships *Charybdis* (flag), *Talbot*, *Eclipse* and *Diana*, was ordered to act as the escort for the troop convoy. Rear-Admiral Wemyss, with three of his ships, arrived at Halifax on Sept. 22, while the *Diana*, which had been delayed with defects reached Sydney

on the 23rd. Rear-Admiral Phipps-Hornby was ordered to shift his flag to the *Lancaster*, and put the *Glory* and *Niobe* under Rear-Admiral Wemyss' command. HMS *Majestic* from the 7th Battle Squadron was ordered to reinforce the escort. It was thought that if the convoy was attacked it would probably be during the second half of the voyage. Just in case this did happen, the C-in-C Home Fleet was ordered to send either HMS *Queen Mary* or *Princess Royal* (battle cruisers) to the rendezvous and to be there by Oct. 2. The *Princess Royal* was detailed, and stayed with the convoy until it reached the Fastnet, off southern Ireland.

Rear-Admiral Phipps-Hornby pointed out that his squadron would be too weak to keep a proper watch on the German ships known to be in U.S. ports, so the *Niobe* was returned to him. On arrival at Halifax, Rear-Admiral Wemyss went up to Quebec to discuss the arrangements for the convoy with the Minister. Rear-Admiral Wemyss asked that the rendezvous at Gaspé Bay and the time of sailing be kept secret. The inhabitants of the area were most co-operative and the secret was well kept.

WEMYSS SAILED with his squadron from Halifax on Sept. 26 and the whole squadron arrived at Gaspé Bay on the 28th. The troop ships arrived in batches, three on Sept. 29, 13 on Oct. 1, 12 on Oct. 2, and two during that night. The Minister visited the anchorage on the 2nd, and distributed copies of his farewell message to the troops. After seeing only four cruisers he became greatly concerned once more about the strength of the escort. He was of the opinion that it was quite inadequate, and said so.

Finally the Admiralty replied that "My Lords are satisfied that every reasonable precaution has been taken and the escort is considered safe. . . The cancelling of the sailing on the ground of inadequate escort will rest, therefore, with the Canadian Government."

However, Admiralty told no one about the plan to support the convoy with a battle cruiser during the second half of the voyage. It seems incredible that they did not tell Rear-Admiral Wemyss who was responsible for the safety of this important convoy.

At 2.30 pm on Saturday, Oct. 3, HMS *Charybdis* made the following signal to the troop ships: "Have cables hove short. All ships in column Z will raise anchor at 3 pm, and proceed, keeping column formation, steaming at 9 knots following leading cruiser *Eclipse*".

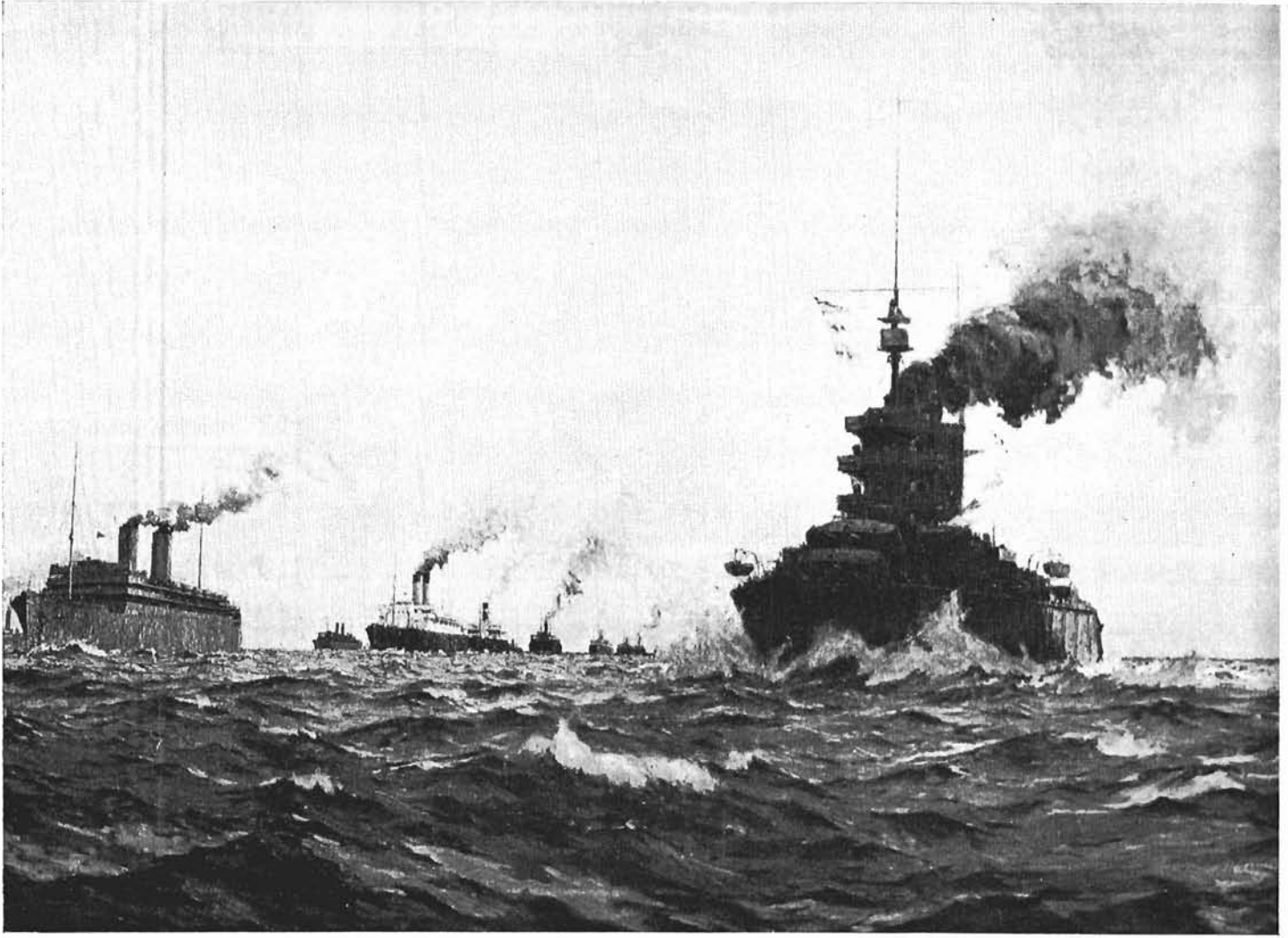

This is how Norman Wilkinson naval officer, war artist and reputed inventor of naval camouflage, portrayed the convoy carrying the First Contingent from Canada in October 1914. An unidentified battle cruiser (either the *Queen Mary* or *Princess Royal*) is shown with some of the 32 liners that carried more than 30,000 officers and men to England. Wilkinson's title: "Canada's Answer". (Courtesy National Gallery of Canada)

Promptly at 3 pm, the *Eclipse* led column Z out of the anchorage, followed by *Diana* with column Y, and in due course astern of her came *Charybdis* leading column X. HMS *Talbot* brought up the rear of the long column which had a total length of 21½ miles. The last ship did not pass the entrance until 6 pm.

The weather was perfect. It has been a fine fall day, and as the land disappeared astern in a setting sun, ahead rose a full moon. It must have been a wonderful sight, and it certainly moved one young soldier in the 16th Battalion (the Canadian Scottish that was to be), as he saw Canada disappear from sight astern, to write that, "I'm proud of being a Canadian". His words on going off to fight for his King and Country might well be taken to heart by his fellow countrymen today. Pride in one's country seems to be the exception rather than the rule these days.

Once formed the convoy proceeded at 10 knots. On Monday morning, Oct. 5, off St. Pierre Island, HMS *Glory* joined.

As the convoy passed Cape Race on Oct. 5 the *Florizel*, with the Newfoundland Contingent, joined the convoy.

While the convoy proceeded on its way, other ships were also moving into position. The *Princess Royal* (battle cruiser) left Scapa Flow early on the 3rd and reached to rendezvous on the night of the 7th. The battleship *Majestic* had arrived a day earlier. Off the American coast the *Suffolk*, *Niobe* and *Caronia* kept watch on the German liners lying in port. The Admiralty's plan was in action, and the grey ships of war were in position, ready to deal with the enemy.

It seems almost incredible that such a thing could happen, but apparently no one thought to tell the Admiralty that the convoy had sailed. By Oct. 6

they were not sure whether the Minister's views on the escort had held it up or not. The previous day the C-in-C Home Fleet asked if the convoy had sailed, so the Admiralty made a signal to Rear-Admiral Wemyss to "report what is position of convoy. Have you assembled and sailed?" His reply was made at 6 am and was received during the afternoon of the 6th. It read "Convoy assembled and left Gaspé Bay Oct. 3. Present position 45.30 N, 52 W, speed 9 knots." The Minister had informed the War Office that the convoy had sailed, but his message of Oct. 4 did not reach the Admiralty until the 6th. As a result this great convoy was at sea for three days without anyone at Whitehall knowing about it.

The *Princess Royal* and *Majestic* spent 2½ days waiting at the rendezvous, all due to the assumption that the convoy would sail on Oct. 1, at 10 knots, as signalled by Rear-Admiral Wemyss be-

fore sailing. In fact it sailed on the 3rd and proceeded at $9\frac{1}{2}$ knots, but nothing appears to have been done to correct the information. He was in touch with both ships by W/T on the 7th, and sighted them at dawn on the 10th.

On the 12th the *Princess Royal* dropped back and then cleared for action, and, with her band playing "O Canada" and "The Maple Leaf Forever", steamed up between columns Y and Z at 22 knots. It must have been a most stirring sight.

It had originally been planned to carry out the disembarkation of the troop transports at Southampton, which was being used almost entirely as a military port. By the end of September U-boats were being reported in the Channel, and it was considered safer to land the First Contingent at some port in the west of England. Devonport was decided upon, but after a visit by members of the Southampton Embarkation Staff who made an adverse report, Southampton was finally selected and Rear-Admiral Wemyss was so informed on Oct. 6.

Certain camp equipment, without which the troops could not be dealt with ashore, was stowed in the *Montreal*, 12 knots, and the *Alaunia*, 14 knots. It was essential that these two should be unloaded first.

These two ships, escorted by the *Diana*, parted company with the rest of the convoy 570 miles west of Scilly at 6.30 pm, Oct. 11. As the rest of the convoy approached the longitude of the Fastnet the escorting cruisers heard what appeared to be strong German wireless calls and Rear-Admiral Wemyss decided not to break up the convoy.

AS THE CONVOY reached the longitude of the Fastnet, there occurred an event which upset all the plans. On Oct. 12, the French had sighted a submarine off Cap Gris Nez and had established a patrol from Cherbourg to the Owers Light Vessel east of Ports-

mouth; in spite of this a submarine was sighted and attacked by one of the torpedo boats of the Portsmouth Extended Defence at 4.30 pm on Oct. 13, at the east end of the Isle of Wight.

The presence of this submarine so near Southampton made that port dangerous for the disembarkation, and the Admiralty ordered the convoy to take shelter in Plymouth Sound till the road to the Needles could be cleared. The same orders were sent to the *Diana*. Her two transports arrived at Devonport at dawn Oct. 14. At the same time Rear-Admiral Wemyss, who had reached Scilly, broke up the convoy and sent the first group to Plymouth, following with the other groups. All arrived safely during Oct. 14. Meanwhile, at the suggestion of the Commander-in-Chief, Portsmouth, orders had been given to the transports not to wait, but for them to carry on disembarking at Plymouth till the submarine in the Channel could be disposed of, and disembarkation officers were sent from Southampton to assist. The submarine situation did not improve and the disembarkation at Plymouth, having once started, continued till the whole convoy had landed at Devonport.

The submarines sighted on Oct. 12 and 13 in the approaches to Southampton had, in fact, been dispatched from Germany with the special mission of attacking the convoy. The German Admiralty on Oct. 8, learnt from their New York agents that 24 transports, escorted by eight warships had left Quebec on Oct. 2, a report which, so far, was very nearly accurate. Boulogne was assumed to be the destination of the force, the date of arrival to be Oct. 10 and 12 and, as the troops were thought to be sufficiently trained to take the field at once, the military authorities wished to have this convoy attacked. Accordingly *U-8* and *U-20* were dispatched on Oct. 10 to operate off Boulogne against it. It was *U-8* that was seen off Cape Gris Nez and *U-20* was met off Culver Cliff, but neither submarine seems to have come so far

west as Plymouth, and thus the convoy escaped a very real danger.

When you stop to consider this great event, it is quite wonderful that Canada was able to raise a force of 30,000 men and land them in the United Kingdom in the space of 10 weeks from the outbreak of the war. What happened to them after landing and on going to France and Belgium belongs to history. The men of the First Contingent and those who followed them made a name for Canada that will never be forgotten. Each man in his own way had his St. Crispin's Day even as those of us who had our part in the Second Great War or in Korea. We all at one time or another found ourselves called upon to put forth that extra, special effort to withstand the assaults of the enemy.

GENTLEMEN, we few, we happy few, we band of brothers, we are of a very special and select company, for we have borne arms in the service of our Sovereign and our Country in the presence of the enemy. To be a member of such a company is not only a privilege, but a very great honour. It has not been given to all men, and I believe that with this privilege and honour goes great responsibility. We, by our service, have an understanding of mankind, because we have lived and fought alongside our fellow countrymen. To us have been given the secrets of Duty—Discipline—Faith—Courage—Endurance—and, I trust, a Sense of Humour. All these qualities we have seen tried and tested in the face of the enemy, and I believe it is our responsibility to see that they remain some of the basic qualities in all Canadians. There is no doubt we all need them today.

Pride of regiment or service, pride of country, faith in a just cause, and above all, great courage, these are some of the qualities that have made your names famous. In these days such qualities are still to be found in those who serve Canada at sea, ashore and in the air.

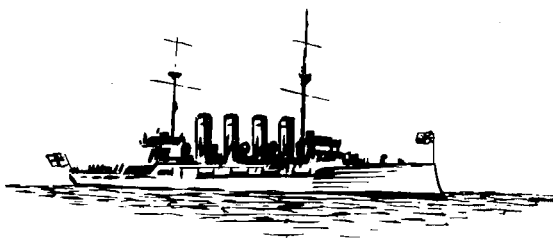

AFLOAT AND ASHORE

ATLANTIC COMMAND

HMCS Terra Nova

During the Fifth Squadron's recent trip to Ireland and England, the men of HMCS *Terra Nova* had the opportunity of touring Ulster and Eire while the squadron was alongside at Londonderry.

The idea originated with Lt.-Cdr. Fred Henshaw, the *Terra Nova's* executive officer. Having a ship overflowing with sub-lieutenants, he thought this would be a fine opportunity for leadership and expedition training, sugar-coated with the chance of seeing the Irish countryside.

Before leaving Halifax in September, sleeping bags, tents, and emergency rations were acquired from the Canadian Army, and four groups of approximately 10 men each were organized, with a sub-lieutenant in charge of each group.

On arrival in 'Derry, the first two groups set off early on a wet, miserable Monday morning for Belfast, where they were to rent cars, mobility being



of the essence. At Belfast, the groups separated, one heading north, the other south, with just the one objective of absorbing as much of the Irish character and countryside as possible, returning to the ship at noon on Wednesday.

Dublin, Donegal, the Giant's Causeway, the Beleek potteries—the list of points of interest visited would take up more space than is available here. Shelter for the night was found in a variety of places, including private houses, camping in the rain and, the prize of

all, a brewery. The Irish people were most friendly and courteous, both north and south of the border and all seemed to take interest in these rather motely groups of Canadian sailors.

The third and fourth groups, touring from Wednesday noon to Saturday morning, found exactly the same friendliness, typified by the parting words of a local in Donegal: "See you all next year!"

As a result of the expeditions, 40 Canadians are now possessors of pleasant memories of a beautiful rural country, albeit a wet one. *Terra Novas* are now wondering where the next expeditions are going, since the Irish one was so successful. Maybe the wilds of Nova Scotia?

HMCS Cornwallis

Leadership Division

Friday, Aug. 21, brought to a close another hectic summer training period in the Leadership Division at *Cornwallis*. A total of 382 regular and reserve force officers and men completed courses during the four-month period.

MAIN STREET FAIR 1964



The Stadacona band made five appearances in Philadelphia on Oct. 7 and 8 in conjunction with Canada Week in that city. Their opening program was at noon on Wednesday, Oct. 7, in the main court of the John Wanamaker store. That same day the band's concert group played at the Main Street Fair, Chestnut Hill Hospital, as pictured here. On Wednesday night the band gave its principal concert, an hour-and-a-half long, in the ballroom of the Trade and Convention Centre. On Thursday the bandsmen were on a 30-minute live television show and then appeared at the Canadian Fashion Show in the Sheraton Hotel ballroom.

Practical segments of each course such as parade training, range, P&RT and the assault course give each individual the chance to demonstrate, to himself as well as to others, what he is capable of doing. The course officers and course instructors also discuss subjects related to the divisional system and the training of regular force and reserve personnel.

Leadership Division is proud of the opportunity to assist in raising the standards of the officers and men of the regular and reserve naval forces. By offering the two-week course to the latter group, we believe that the RCNR will be an even more effective force for this nation. Although instruction is directed toward the regular service, most of what is taught is applicable to all walks of life. This knowledge will be of lasting benefit even if the individuals spend only a short time in the RCNR.

One fact that is made clear to all trainees, is that the best method of teaching is by example and by having a desire to impart knowledge to those with less experience or training.

What was at first a rumour, then a plan finally became a reality on Aug. 3. On that day, boatswain training moved to *Cornwallis*. This important trade now forms a section of Leadership Division. The move was one of major proportions as truckloads of equipment arrived from HMCS *Stadacona*. Much pre-planning had taken place as the OIC Bos'n, Lt.-Cdr. D. B. Lawrence, and the Staff Officer (Admin), Cd. Off. D. E. Hall, had completed the preliminary work to make the move as smooth as possible.

The UNTD Navigation School will be the headquarters of boatswain training, with seamanship classes remaining in "G" Galley.

The Cyclic System will also give a great boost to the quantity of trainees in this section in the New Year.

RCNR training dominated the schedule, accounting for 307 trainees, including No. 21 Officers' Course; UNTD First Year Cadets; No. 4 Advanced Leadership Course; Petty Officers' Junior Leadership Course and No. 4 and No. 5 Leading Seaman Junior Leadership Courses.

To manage the large expansion in the numbers of trainees during the summer months, reserve officers are appointed to Leadership Division to carry the responsibilities of course officer and instructor. This season, Lieutenants M. Shiner and J. Watkins, of *York*, T. O'Connell of *Scotian*, W. Turner of *Nonsuch*, and Sub-Lieutenant M. Flood, of *Scotian*, supervised the training of ten reserve courses each of two weeks



A thoroughly navy-minded family attended the officer training establishment, HMCS *Venture*, Esquimalt, for the recent graduation of one of its members, Sub-Lt. Robert Montgomery. From left to right are his father, Lt.-Cdr. C. W. Montgomery, assistant professor in mathematics at the Canadian Services College, Royal Roads; Sub-Lt. Montgomery, with his sister, Kathryn Anne; his mother, and brothers, Cadet James Montgomery, a second-year ROTP naval officer cadet attending the University of Victoria, and Paul F. Montgomery, an able seaman at HMCS *Malahat*, Victoria naval division. Newly-commissioned Sub-Lt. Montgomery has been appointed to the destroyer escort *St. Laurent*, serving out of Halifax. (E-78265)



A monument to the memory of 15 sea captains bearing the name Rawding was unveiled on Sept. 15 in Clementsport, a neighbouring village of HMCS *Cornwallis*. Captain J. M. Paul, commanding officer, *Cornwallis*, gave the official address commemorating these sea captains who for 150 years sailed the high seas. In the "family" of sea captains there was one set of five brothers and two sets of two brothers. Two of the master mariners are still alive and sailing. Mrs. Winnifred Morgan, a daughter of one of the five brothers, was present with her daughter, Mrs. Henry How, who did the unveiling. (DB-19358)

duration. When the summer training season ended, these officers returned to their vocations or studies.

Four RCN officers' divisional courses were included in the summer agenda. No. 68 limited duty officers were a part of the division for six weeks and were re-introduced to the Navy way of life after 42 weeks of schooling at HMCS *Naden*.

The LDO course, as in the past, was popular in *Cornwallis* as the members responded well to instruction. For the first time the Canadian Naval Association presented a sword to the limited duty officer of the year. Cd. Off. Thomas Miller, of No. 68 Course, received this important award from the president of Canadian Naval Association, H. A. Maynard, during ceremonial divisions on July 3. The initiation of the award is of great value to all future courses and should create much competition and incentive.

Three classes of pre-Fleet sub-lieutenants arrived to complete one stage of their RCN indoctrination. The young officers were fresh from Canadian Services Colleges or Canadian universities and eager to join the Fleet.

The regular force staff at Leadership Division continued to change during the summer months and by September seemed to have the new appointment phase completed. Lt.-Cdr. R. C. Brown became the officer-in-charge, arriving directly from commanding the *New Waterford*. His predecessor, Lt.-Cdr. D. M. Waters, moved to Upper Canada as executive officer, HMCS *Hochelaga*. Lt. Charles Phillips packed his belongings for the long trip to the West Coast where he will be on staff of the Apprenticeship School. Lt. A. M. Mac-Innis also became a member of the staff at *Hochelaga* and will instruct RCN personnel in the French language. CPO J. Watson's thundering voice became history on Aug. 3 as he took up his new duties as master-at-arms in



Wren Donna Walker, "Miss Fire Prevention 1964", receives from His Worship Mayor Charles Vaughan, of Halifax, the plaque for best service float in the 1964 Halifax Natal Day parade. Wren Walker, who serves in HMCS *Stadacona's* Supply Department, was the chief adornment of the Dockyard Fire Department's winning float. She won her title over five other wrens serving in the Halifax-Dartmouth area. (HS-75740)

HMCS *Gloucester*. Other new faces in Leadership Division are those of Lt. Don Boudreau, as Projects Officer, Lt. C. W. Turner, as Course Officer, and CPO K. P. Keysell and PO H. O. Perry as Course Instructors. Lt. A. M. Baird and CPO W. Warner are now the only persons at Leadership Division who have been there for over 12 months.

There is no doubt at all that many busy months are ahead. The Cyclic System has made it possible for an increased number of RCN petty officers to attend the six-week divisional course. The division can now expect a minimum of six courses of 60 men in each. The increased number passing through Leadership should be of lasting benefit to the Fleet and to the individual. The regular force courses of LDO and direct entry officers will continue at their normal rate.

Each course attending Leadership Division begins its training conscious of the amount the members must learn and for all, the weeks following prove to be strenuous, but satisfying. Lectures are designed to uncover and develop leadership qualities necessary to effectively guide and administer the modern navy.

HMCS *Kootenay*

Five sea cadets, selected from coast to coast applications by the Navy League of Canada, sailed with HMCS *Kootenay* on July 20 on a cruise to the Bermuda area and New York. For most of them, it was their first time on board

a warship and for all cadets this was their first cruise.

During their four weeks on board, time was spent in each department covering all phases of shipboard life. They witnessed torpedo and mortar firings and gunnery shoots, and were in the engine and boiler rooms during manoeuvres. Lectures were given on anchors and cables, mortars, torpedo launchers and small arms. They had descriptive tours of the communications and electrical departments.

At night they stood upper deck watches as lookouts and in the wheelhouse. Basics of seamanship were learned when they fell in with the duty watch to lower sea boats, come alongside in harbour or store ship. Rounding out seamanship, they took part in a jackstay transfer and fuelling at sea.

All work and no play . . . so when the *Kootenay* entered Bermuda between exercises, there was time for the renting of motor scooters and tours of the island, or to soak up the sun along the sandy beaches.

In New York, during the four-day visit, there was a Yankee baseball game, the World's Fair, and a host of other interesting items and events including a show at Carnegie Hall and a beach party at Jones Beach.

On arrival back at Halifax on Aug. 14, the sea cadets departed for their homes with a broader knowledge of the world and wiser to the ways of the Navy.

HERE AND THERE IN THE RCN



Hon. Lionel Chevrier, High Commissioner for Canada in London, accompanied by Madame Chevrier, visited HMC Ships Chaudiere and Terra Nova at Portsmouth, England, on Oct. 30. The ships had been exercising in British waters. Mr. Chevrier is shown going on board, followed by Captain G. H. Hayes, Deputy Naval Member, Canadian Joint Staff, London. (Royal Navy Photo)



Major-General E. C. Plow, former Lieutenant Governor of Nova Scotia, accepts a cheque for the Children's Hospital Building Fund from Wren Nina Francis as Nancy Morris, a patient at the present Children's Hospital, looks on. The money was donated by the Stadacona Ship's Fund. (HS-76287)



After 16 years of service as stationary engineer at HMCS Donnacona, Montreal's naval division, William Jones has retired from the civil service. His retirement was marked by the presentation of a tray from the naval and civilian staff and a framed scroll, by Lt.-Cdr. D. W. Swan, staff officer, on behalf of Commodore M. J. Jette, Senior Naval Officer, River St. Lawrence Area. (ML-14047)



Integration, international style, was encountered by Captain L. J. Nairn, Pacific Command Supply Officer, when he took up his new appointment recently. He found two supply officers serving in Esquimalt on exchange duties from the United States Navy and the Royal Navy. Left to right are: Lt. Duane Hinds, USN, of Montrove, Pennsylvania, Cdr. H. T. Cocks, RCN, Officer-in-charge Naval Supply Depot, HMC Dockyard; Captain Nairn and Lt. Tim Rogers, RN, of Milford-on-Sea, Hampshire, England. (E-78384)

THE NAVY PLAYS

Albro Lake Team Tops in Softball

In the Intermediate "B" softball league in the Maritimes there is no team in a class with the one from Naval Radio Station Albro Lake, Dartmouth.

In the Dartmouth area they won the lead last summer with 17 straight wins (a record) and defeated the Volvo team 3 out of 5 in the finals to gain possession of the Noseworthy trophy.

The team went on to capture the provincial championship and the Herb Smart trophy before downing Gagetown two out of three games for the Maritimes championship.

During the season the team was wholly self-supporting, with each player even buying his own uniform.

Pacific Command Pearkes Winner

The RCN Pacific Command soccer team won the G. R. Pearkes soccer trophy at Camp Gagetown, N.B., in the Armed Forces soccer championship tourney October 8, 9 and 10.



Air Force Cadet Stanley Gidley of Comox and Vancouver was the first man across the finish line with 200 officer cadets at the Canadian Services College, Royal Roads, raced 4.3 miles around Hatley Park in an interflight cross-country run on Oct 22. Timer is Staff Sgt. D. F. Wilson of the college drill staff. Cadet Gidley, son of Flight Sgt. and Mrs. S. R. Gidley, stationed with the RCAF at Comox, ran the course in the time of 22:42:5. College record for the run is 20:56:4, set in 1962 by Cadet John Carswell, of Saraguay, Que. (RR-3506)



This is the Albro Lake Naval Radio Station team that won 17 softball games in a row last summer and went on to take the Maritimes Intermediate "B" softball league championship. Front row, Gregor Garry, James Dauphinee and D. W. King; middle row, J. L. Murphy, G. E. Robillard, F. E. Rollet, F. A. Gray, J. D. Maclaren and J. F. Frame, and, back row, D. E. Glover, Douglas MacGregor, B. C. Smith, Robert Pitman and Patrick Devine.

It marked the first time that the Navy had won the trophy, which last year was captured by RCAF Penhold, Alberta. The Pacific Command team took the cup by defeating Black Watch 2-1 in overtime. Earlier, the navy stalwarts downed RCAF Winnipeg 6-1 and HMCS *Stadacona* 6-0.

The winning navy goal was scored by Nigerian apprentice Bonnie Egbunobi in the second overtime period. The first navy goal was scored by team captain Ldg. Sea. Bob Marsden at the 15-minute mark on a penalty kick. The lone Black Watch goal was scored by George Whelan late in the second half.

In all, seven teams took part in the championship after having won their regional sections.

Coach of the Pacific Command team was PO Bill Lewis. Team manager is W. C. Curry.

Montreal Team Downs Sailors

Montreal Wanderers, fresh from a 16-3 victory over *Shearwater* Falcons on Oct. 31 that saw them walk off with

the MacTier Cup, defeated *Stadacona* Sailors, 6-5, in an exhibition rugby match on Sunday afternoon Nov. 1.

The Sailors jumped out in front early in the contest with John Slade crossing the line for three points. The convert was good making the score 5-0 for *Stadacona* at the end of the first half.

However, the Wanderers rebounded quickly and scored two unconverted tries in the final 40 minutes to give the visitors the 6-5 win.

Hockey Clinic At Cornwallis

The second annual hockey clinic for referees, held at *Cornwallis* Nov. 5-7, was expanded this year to include maritime servicemen as well as civilians, the first one having been such a success.

PO B. A. (Spud) Hughes, a PTI and longtime referee, was instructor at this year's clinic, in which he was assisted by guest instructors from the Maritime Hockey Referees' Association. The clinic included lecture room and ice time.

Cadets Tackle Obstacle Course

One hundred and twenty or more recruits slithered, slipped, climbed, scrambled, waded and swam their way to the status of junior cadets at *Royal Roads*, Canadian Services College, on the afternoon of Oct. 16.

A two-mile obstacle course, with just about every uncomfortable impediment to progress thrown in, was covered by the cadets in good time (about 34 minutes was the best) to mark the end of their first six weeks in the armed forces as officer cadets.

Not much more than an hour after the last of them finished the course, they were sitting down to a formal mess dinner. Gone were their "fuzzy-wuzzies" (a cadet tag for the woolly battle dress they started with), on were the smart blue tunics and trousers with red stripes.

Even though the studies had been hard, the athletic activity demanding and the parade square drill monotonous, the cadets were started on a career.

Next year, they will be seniors at *Royal Roads* and next year there will be more recruits.

NELSON'S LETTER FOR NEW MUSEUM

AN ORIGINAL LETTER from Lord Nelson, written in his own hand two years before the Battle of Trafalgar, has been presented to the Royal Australian Navy by a Sydney businessman.

The Australian Minister for the Navy, Mr. Chaney, said that the letter, written on board the *Victory* in 1803, would be a prized exhibit in an Australian museum of naval history.

Mr. Chaney said the letter had been generously donated by H. C. Adney, of Great North Road, Five Dock, N.S.W. It is intended that with other historical naval material, it one day will go on display in a museum which the Navy plans to establish in Canberra.

Lord Nelson's letter was written to Captain George Frederick Ryves, HMS *Gibraltar*, Naples, on the 8th of October, 1803, during operations in the Mediterranean.

The historic letter reads:

"Dear Sir,

I am much obliged by your letter of September 20th and for the trouble you have taken about the wood at the Madalena Islands. His Excellency Mr. Elliot will request you to see the Neapolitan troops safe to Messina, which, if not already performed, I am sure you have, or will have complied with. We had nothing but severe gales of wind since you left us, but we get on very well. The *Monmouth* was only five days to Cape Sicie but we were blown off. I am dear sir with real esteem, your obliged and obedient servant.

NELSON AND BRONTE.

"The *Childers* is not to be detained on any account."

In 1803 Lord Nelson was commanding the British Fleet in the Mediterranean, and the letter refers to operations during the blockade of the French Fleet in Toulon. Captain Ryves had informed Nelson of a safe anchorage at the Madalena Islands, and the letter expresses thanks for the preparation of wood for fuel.

Nelson was anchored at Madalena when, in 1805, two British lookout frigates came into sight flying the signal that the French Fleet was at sea. Nelson sailed in pursuit and never returned.



This year's *Royal Roads* cadets ended their six-week recruit period by slipping, climbing, wading and swimming through, under and over a two-mile obstacle course. The cadets first climbed a scramble net. Mud, and lots of it, came later. (RR-3460)



RETIREMENTS

CPO CARMAN LUTHER BENJAMIN, CD and 1st Clasp; C2CK3; joined RCNVR March 10, 1940; transferred to RCN Aug. 11, 1946; served in *Stadacona*, *Assiniboine*, *Restigouche*, *Prince David*, *Montreal*, *York*, *Shelburne*, *Somers Isles*, *Cornwallis*, *Niobe*, *Warrior*, *Magnificent*, *Shearwater*, *Star*, *Patriot*, *Bonaventure*, *Athabaskan*; retired October 21, 1964.

CPO CYRIL JOSEPH COOTE, CD; C1ER4; joined RCNVR Oct. 3, 1939; transferred to RCN March 11, 1943; served in *Stadacona*, *Pugwash*, *Mayflower*, *Burlington*, *Hunter*, *Cornwallis*, *HMS Seymour*, *Niobe*, *Teme*, *Matane*, *Peregrine*, *Scottian*, *Newport Corners* naval radio station, *Iroquois*, *Portage*, *La Hullose*, *Llewellyn*, *New Liskeard*, *Resolute*, *Athabaskan*; retired October 2, 1964.

CPO COLIN ARTHUR EDWARD DREW, CD; C1CD4; joined RCNVR Dec. 12, 1937;

transferred to RCN May 20, 1944; served in *Calgary* naval division, *Naden*, *Prince Robert*, *Princess Marguerite*, *Spondelius*, *Ikauna*, *Reynella*, *Kootenay Park*, *Givenchy*, *Princess Eloise*, *Stadacona II*, *Kirkland Lake*, *Niobe*, *Peregrine*, *Cornwallis*, *Medicine Hat*, *Uganda*, *Ontario*, *Bytown*, *Niagara*; retired October 9, 1964.

CPO CLAYR WILLMOTT HENDERSON, CD; C1FC4; joined RCNVR Nov. 5, 1941; transferred to RCN May 1, 1942; served in *Star*, *Nonsuch*, *Stadacona*, *Cornwallis*, *Givenchy*, *Courtenay*, *Sackville*, *Peregrine*, *Prescott*, *Avalon*, *Kincardine*, *Scotian*, *Winnipeg*, *Oshawa*, *Ontario*, *Niobe*, *HMS Collingwood*, *HMS Excellent*, *Naden*, *Cayuga*, *Rockcliffe*, *Sioux*, *Naden*, *Athabaskan*, *Fraser*, *HMS Victory*; retired October 30, 1964.

CPO STEWART EDWARD MacRAE, CD; C2ER4; joined RCNVR April 18, 1942; trans-

ferred to RCN Sept. 12, 1945; served in *Montreal* naval division, *York*, *Cornwallis*, *Avalon*, *Stadacona*, *Rimouski*, *Peregrine*, *Hochelega II*, *New Liskeard*, *Micmac*, *Nootka*, *Iroquois*, *La Hullose*, *Haida*, *Crescent*, *Algonquin*, *Ottawa*, *Terra Nova*, *Columbia*; retired October 29, 1964.

CPO GEORGE JOSEPH MALEFANT, CD and 1st Clasp; C1PM4; served in RCNVR Sept. 22, 1939 to Dec. 4, 1945; joined RCN Oct. 9, 1946; served in *Winnipeg* naval division, *Naden*, *Stadacona*, *Avalon*, *Chippawa*, *Rockcliffe*, *Ontario*, *Cornwallis*, *Cape Breton*; retired October 6, 1964.

PO DONALD WILLIAM GEORGE TRIM, CD; P1BD3; joined RCNVR July 11, 1944; transferred to RCN Oct. 27, 1944; served in *Star*, *Brunswick*, *Captor II*, *Cornwallis*, *Peregrine*, *Niobe*, *Crescent*, *Naden*, *Ontario*, *Stadacona* *Cornwallis*; retired October 26, 1964.

OFFICERS RETIRE

LT. DENNETT ALFRED ALBERT ARNOLD, CD; commenced service Dec. 19, 1951, in the RCN as Commissioned Officer (SB); served in *Malahat*, *Naden*, *Cornwallis*, *Stadacona*, *Unicorn*, *Chippawa*; last appointment, HMCS *Unicorn* as Area Recruiting Officer, Saskatchewan; commenced leave Oct. 17, 1964; retires on Feb. 4, 1965.

LT. KENNETH JOHN BARKLEY; commenced service in RCN Sept. 16, 1953, as an ordnance cadet; served in *Chippawa*, *Naden*, *Sussexvale*, *Stettler*, *Montcalm*, *Bonaventure*, *Stadacona*, *Niobe*, *HMS Excellent*, *HMS Vernon*, *Crescent*, *Nootka*, *Bytown*; last appointment Naval Headquarters on staff of Assistant Director of Fleet Maintenance (Planned Maintenance); retires on Sept. 30, 1964.

CDR. FREDERICK WILCOX HERBERT BRADLEY, CD; commenced service in the RCNVR on July 26, 1940, as an ordinary seaman; served in *Stadacona*, *HMS President*, *HMS Victory*, *HMS Vincent*; promoted to sub-lieutenant on Oct. 6, 1964; served in *HMS Vulture*, *HMS Jackdaw*, *HMS Condor*, *HMS Landrail*, *HMS Indomitable*, *HMS Daedalus*, *HMS Begum*, *HMS Bambara*, *HMS Merganer*, *Niobe*, *Bytown*, *Carleton*; demobilized Feb. 26, 1946; entered RCN(R) as lieutenant (P) Sept. 7, 1946; transferred to RCN July 15, 1947; served in *Donnacona*, *Stadacona*, *Niobe*, *HMS Daedalus*, *HMS Heron*, *HMS Fulmar*, *HMS Vulture*, *Niobe*, *Bytown*, *Magnificent*, *Shearwater*, *Crusader*, *Patriot*; last appointment HMCS *Patriot* in command and on staff of Commanding Officer Naval Divisions as Deputy Chief of Staff and as Chief Staff Officer Operations and Administration Division and as Command Security Officer; commenced leave Sept. 2 1964; retires on Feb. 17, 1965.

LT.-CDR. EDWARD BURNETT, CD; commenced service in the RCNR on Jan. 6, 1936; as a probationary stoker; promoted to acting warrant engineer on May 1, 1943; served in *Armentieres*, *Skeena*, *Naden*, *Givenchy*, *Kelowna*, *Stadacona*, *Vegreville*, *Bellechasse*; demobilized Feb. 5, 1946; entered RCN as Engine Room Artificer 4th Class on Jan. 6,

1947; promoted to acting warrant engineer July 1, 1949; served in *Naden*, *Warrior*, *Stadacona*, *Ontario*, *Cornwallis*, *Sussexvale*, *Bytown*, *Cape Breton*; last appointment HMCS *Naden* on staff of Commodore Superintendent Pacific Coast for Planning Department Ship Repair Activity; commenced leave Oct. 4, 1964; retires on March 9, 1965.

LT.-CDR. ARCHIBALD DOUGLAS CALDWELL, CD; served in RNVR from March 1937 to January 1946; commenced service in the RCN(R) on April 26, 1951, as lieutenant (G); transferred to RCN as lieutenant (G) on May 22, 1951; served in *Star*, *Stadacona*, *Donnacona*, *Naden*, *Ontario*, *Bytown*, *Patriot*, *York*; last appointment HMCS *Patriot* on staff of Commanding Officer Naval Divisions as Secretary and as Flag Lieutenant; commenced leave Aug. 31, 1964; retires on June 11, 1965.

SURGEON CAPTAIN GEORGE WILLIAM CHAPMAN, CD; commenced service in the RCNVR on Feb. 17, 1941, as a surgeon lieutenant; served in *Stadacona*, *Bytown*, *Niobe*; transferred to RCN as surgeon lieutenant-commander on Sept. 8, 1945; served in *Donnacona*, *Ontario*, *Bytown*, *Stadacona*, *Discovery*, *Naden*, *Beacon Hill*; last appointment HMCS *Stadacona* as Regional Surgeon Atlantic Medical Region; commenced leave Sept. 29, 1964; retires on April 24, 1965.

LT.-CDR. EDWARD ALBERT FALLEN, CD; served in RCAF from 1941 to 1945; commenced service in the RCN(R) on April 17, 1947 as an acting lieutenant (P); served in *Bytown*, *Magnificent*, *Stadacona*, *Shearwater*, *Niagara*, *Labrador*, *Bonaventure*; last appointment HMCS *Shearwater* in *HS-50*, in command; commenced leave Oct. 20, 1964; retires on Feb. 16, 1965.

LT. EDWARD JOSEPH GAYDA, CD; commenced service in the RCN on May 3, 1947, as a probationary stores assistant; served in *Queen*, *Naden*, *Unicorn*, *Ontario*, *Cornwallis*, *Discovery*, *Stadacona*, *Labrador*, *Gloucester*, *Hochelega*, *Patriot*; last appointment HMCS *Naden* on staff of Officer-in-Charge Naval Supply Depot, Esquimalt; commenced leave Sept. 7, 1964; retires on Jan. 18, 1965.

LT.-CDR. LEONARD RAYMOND JOHNS, CD; commenced service in the RCN on March 1, 1937, as an acting engine room artificer, 4th class; promoted to acting warrant engineer, on Jan. 15, 1943; served in *Naden*, *Skeena*, *St. Laurent*, *York*, *Stadacona*, *Prince Robert*, *Avalon*, *Cornwallis*, *Hochelega*, *Hal-lowell*, *Mahone*, *Glace Bay*, *Peregrine*, *Beacon Hill*, *Grou*, *Givenchy*, *Uganda*, *Royal Roads*, *Magnificent*, *Sioux*; last appointment HMCS *Naden* on staff of Commodore Superintendent Pacific Coast for Planning Department Ship Repair Activity; commenced leave Oct. 2, 1964; retires on April 20, 1965.

CDR FRANCIS JAMES JONES, CD; commenced service in the RCNR on Aug. 23, 1940, as an able seaman; transferred to RCNVR and promoted to probationary sub-

PROMOTIONS

The following is a list of promotions to the rank shown, in the *Gloucester* Port Division effective June 1, 1964:

REED W. A.	5575-G	C1RS4
ZWICKER L. E.	6887-G	C2RS4
HAYWARD E. E.	5557-G	C2RS4
BURSEY G. F.	13581-G	C2RS4
CORMIER F. E.	14523-G	C2RS4
STEVENS W.	11592-G	P1RS3
BUCHANAN A. G.	11780-G	P1RS3
SEARLE A. F.	13596-G	P1RS3
PAINE N. A.	27005-G	P1RS3
JENNINGS G. G.	34234-G	P1RS3
HAMM B. E.	12219-G	P1RS3
STEWART H. D.	25040-G	P1RS3
ROBITAILLE J. R.	9526-G	P1RS4
FERGUSON W. R.	17772-G	P1RS4
COLP C. J.	24997-G	P1RS3
DAWSON J. P.	8539-G	P1RS3
KILEN P. C.	17322-G	P1RS3

In addition to the above LSR53 J. W. DICKENS, 31245-G was promoted to P2RS3 effective March 1, 1964.

lieutenant Jan. 1, 1941; served in *Royal Roads, Hochelaga, Saskatoon, HMS Persian, Niobe, Mimico, Stadacona, Matane, Donnacona*; demobilized on Nov. 5, 1945; entered RCNR as lieutenant-commander June 27, 1946; transferred to RCN as lieutenant-commander Jan. 22, 1951; served in *Donnacona, Stadacona, Bytown, Niobe, Wallaceburg, Cape Scott*; last appointment Naval Headquarters on staff of Director Naval Operations; commenced leave Sept. 26, 1964; retires on March 1, 1965.

LT.-CDR. JEAN PAUL JORDAN, CD; commenced service in the RCNVR on March 24, 1942; as a writer; promoted to probationary paymaster sub-lieutenant Aug. 2, 1944; served in *Cartier, Stadacona, Cornwallis, Fort Ramsay, Donnacona*; transferred to RCN as lieutenant (S) May 30, 1946; served in *Donnacona, Stadacona, Bytown, Magnificent, Iroquois, Coverdale, Nootka, Patriot, Shearwater, Algonquin, Niagara*; last appointment HMCS *Niagara* as Secretary to Naval Member Canadian Joint Staff Washington; commenced leave Oct. 24, 1964; retires on May 12, 1965.

LT.-CDR. THOMAS ARCHIBALD STUART KADEY, CD; commenced service in the RCNVR as a probationary sick berth at-

tendant; served in *Stadacona, Avalon, Peregrine*; transferred to RCN as sick berth attendant Dec. 10, 1954; promoted to acting



commissioned wardmaster on Oct. 1, 1950; served in *Stadacona, Iroquois, Portage, St. Stephen, Cornwallis, Naden, Bytown, Star, Tecumseh, Royal Roads*; last appointment HMCS *Cornwallis* for Naval Hospital as

Medical Administrative Officer; commenced leave Sept. 3, 1964; retires on March 22, 1965.

LT.-CDR. JOHN ROBERT SUTHERLAND, CD; commenced service in the RCNVR on March 14, 1940, as a writer; served in *Stadacona, Protector, Niobe, HMS Diadem, Peregrine*; transferred to RCN as writer on Dec. 12, 1940; promoted to acting sub-lieutenant (S) on May 1, 1946; served in *Givenchy, Naden, Rockcliffe, Bytown, Iroquois, Swansea, La Hullose, Bytown, Hunter, Donnacona, Hochelaga, Margaree*; last appointment HMCS *Naden* on staff of Flag Officer Pacific Coast as Inspector Supply and Fleet Accounting West Coast; commenced leave Oct. 1, 1964; retires on March 29, 1965.

LT.-CDR. EARL DOUGLAS THOMPSON, CD; commenced service in the RCNR on Nov. 6, 1938, as a probationary stoker; served in *Naden, St. Laurent, Malaspina, Haro, Quesnel, Vancouver, Givenchy, Burrard, Sudbury, Bytown, Scotian, Stadacona*; transferred to RCN as acting engine room artificer, 4th class; promoted to acting warrant on May 1, 1943; served in *Scotian, Iroquois, Stadacona, Haida, Magnificent, Niobe, Niagara, Cornwallis, Cape Scott, Granby*; last appointment HMCS *Naden* for Diving Establishment West Coast; commenced leave Oct. 5, 1964; retires on May 2, 1965.



This study in perspective was taken on the occasion of the visit of His Honour, Lieutenant Governor G. R. Pearkes, VC, to HMC Dockyard, Esquimalt, on Oct. 30 to return the call made by the new Flag Officer Pacific Coast, Rear-Admiral M. G. Stirling. (E-78577)

Naval Lore Corner

Number 132
"CURIOS AT SEA"

IN THE EARLY DAYS OF STEAM-POWER THE NAVIES OF THE WORLD LAUNCHED MANY NEW CLASSES OF WARSHIP TO MEET THE NEW CHALLENGES OF THE DAY. SOME WERE INDEED BIZARRE...

THE TWO RUSSIAN MONITORS OF THE "NOVGOROD" CLASS (1873) WERE COMPLETELY CIRCULAR AND DISPLACED 2,490 TONS. ARMED WITH TWO 11-INCH GUNS, THEY WERE PROPELLED (AND STEERED) BY SIX PROPELLERS...

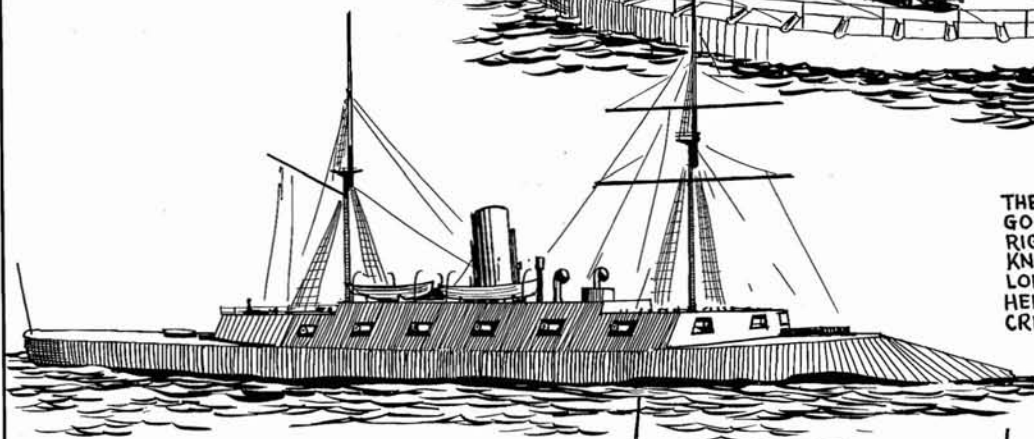
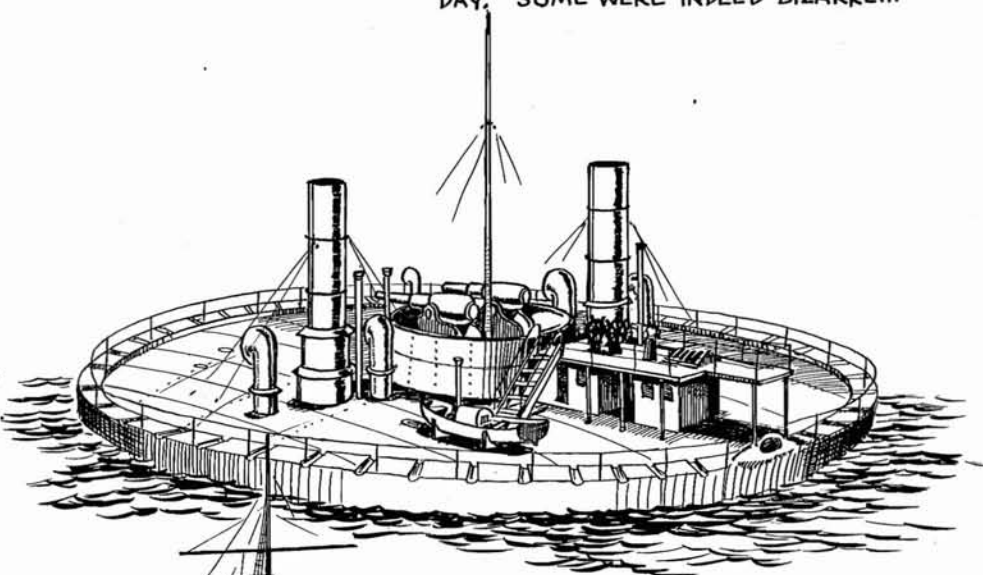

THE U.S.S. DUNDERBERG (1865) "OCEAN-GOING IRONCLAD RAM" WAS FRIGATE-RIGGED AND COULD STEAM AT 15 KNOTS. HER RAM-BOW WAS 50 FEET LONG AND SHE DISPLACED 7,000 TONS. HER ORIGINAL ARMAMENT (LATER INCREASED) INCLUDED TWO 15-INCH AND EIGHT 11-INCH DAHLGREN SMOOTH-BORES. CLAIMED AS THE MOST POWERFUL SHIP AFLOAT, SHE WAS COMPLETED TOO LATE FOR THE CIVIL WAR AND WAS SOLD TO FRANCE AND RENAMED "ROCHAMBEAU"

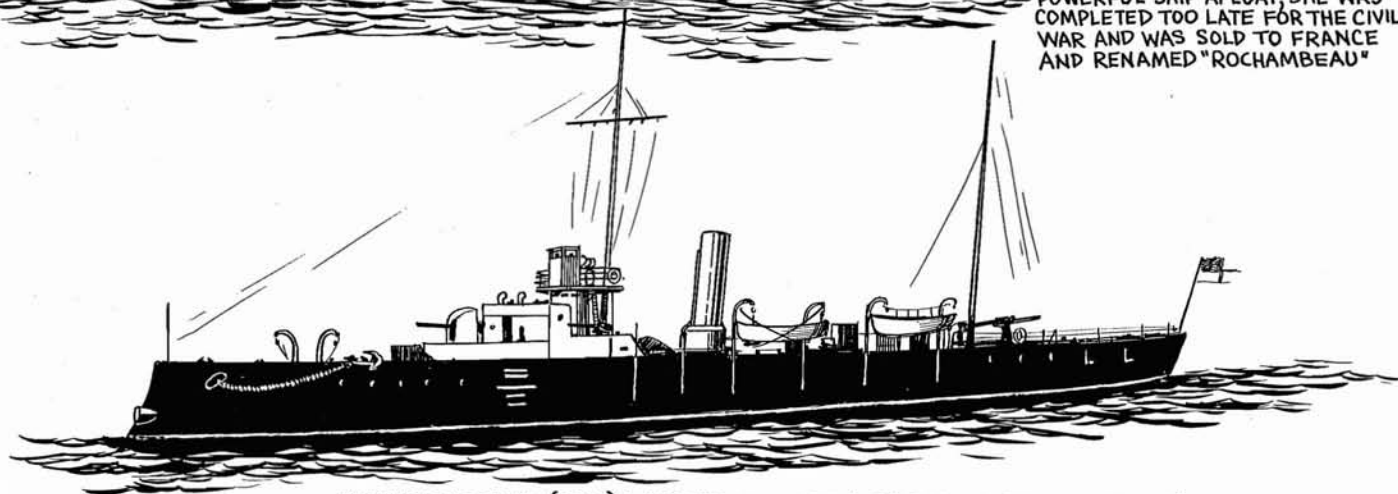

H.M.S. RATTLESNAKE (1887) WAS THE FIRST OF A TYPE OF VESSELS TERMED "TORPEDO CATCHERS".... DESIGNED TO CATCH AND DESTROY TORPEDO BOATS (THEN A NEW 'MENACE' IN NAVAL WARFARE). ARMED WITH ONE 4-INCH GUN AND SIX 3PDR.6 (PLUS TWO TORPEDO TUBES) SHE STEAMED AT 18.5 KNOTS.... TOO SLOW TO CATCH A T.B. AS A CLASS THESE SHIPS WERE BASICALLY FAULTY, BEING TOO SLOW, WEAK AND CLUMSY FOR THEIR JOB (RATTLE-SNAKE WAS ACTUALLY 'CAPTURED' BY A T.B. DURING THE 1890 MANOEUVRES!) THE ADMIRALTY, HOWEVER, BUILT 22 MORE TORPEDO-CATCHERS WITH A PERSISTENCE THAT WAS ALMOST PATHETIC UNTIL THE TYPE WAS ABANDONED, THEIR DESIGNED FUNCTION BEING INHERITED BY THE NEW TORPEDO BOAT DESTROYERS...

CANADA
POSTAGE PAID
PORT PAYÉ

*If undelivered,
return COVER WITH CONTENTS to:*
The Queen's Printer, Ottawa, Canada

*En cas de non-livraison,
retourner cette PUBLICATION INTACTE à:*
L'Imprimeur de la Reine, Ottawa, Canada

