

---

**REPORT ON THE STATUS OF GROUND FISH STOCKS  
IN THE CANADIAN NORTHWEST ATLANTIC**

---

---



---

**Report on the Status of Groundfish Stocks  
in the Canadian Northwest Atlantic**

**Table of Contents**

Introduction .....	5
1. Overview of Groundfish Stocks	
1.1. General Overview of Commercially Exploited Groundfish .....	5
1.2. Overview of Commercially Exploited Groundfish on the Newfoundland Shelf and on the Grand Banks. ....	7
1.3. Overview of Commercially Exploited Groundfish in the Gulf of St. Lawrence .....	10
1.4. Overview of Commercially Exploited Groundfish on the Scotian Shelf and on Georges Bank .....	11
1.5. Environmental Conditions .....	14
2. Stock Status Summary Sheets	
2.1. Cod in 2J+3KL .....	16
2.2. Cod in 3Ps .....	17
2.3. Cod in 3Pn,4RS .....	18
2.4. Cod in 4T-Vn (January-April) .....	19
2.5. Cod in 4Vs and in 4W .....	20
2.6. Cod in 4X .....	21
2.7. Cod in 5Zj and in 5Zm .....	22
2.8. Haddock in 4TVW .....	23
2.9. Haddock in 4X .....	24
2.10. Haddock in 5Zj and 5Zm .....	25
2.11. Pollock in 4VWX+5Zc .....	26
2.12. Redfish in the Gulf of St. Lawrence (4RST, 3Pn (Jan.-May) and 4Vn (Jan.-May)) .....	27
2.13. American Plaice in Subarea 2 and 3K .....	28
2.14. American Plaice in 3Ps .....	29
2.15. American Plaice in 4T .....	30
2.16. American Plaice in 4VW .....	31
2.17. American Plaice in 4X .....	32
2.18. Witch in 2J3KL .....	33
2.19. Witch in 3Ps .....	34
2.20. Witch in 4R and 4S .....	35
2.21. Witch in 4VW .....	36
2.22. Witch in 4X .....	37
2.23. Yellowtail in 4VW .....	38

2.24.	Yellowtail in 4X . . . . .	39
2.25.	Atlantic Halibut in 3NOPs and 4VWX . . . . .	40
2.26.	Atlantic Halibut in 4RST . . . . .	41
2.27.	Greenland Halibut in 4RST . . . . .	42
2.28.	Cod in 4Vn during May to December . . . . .	43
2.29.	Redfish in 2+3K . . . . .	44
2.30.	Redfish in 30 . . . . .	45
2.31.	Redfish in Laurentian Channel . . . . .	46
2.32.	White Hake in 4T . . . . .	47
3.	Figures . . . . .	48
4.	Descriptive stock narratives	
4.1.	2J3KL Cod . . . . .	105
4.2.	3Ps Cod . . . . .	108
4.3.	Cod in 3Pn and 4RS . . . . .	110
4.4.	Cod in 4T & 4Vn (January to April) . . . . .	112
4.5.	Cod in 4VsW . . . . .	114
4.6.	Cod in 4X . . . . .	116
4.7.	Cod on Georges Bank (5Zj and 5Zm) . . . . .	118
4.8.	Haddock in 4TVW . . . . .	120
4.9.	Haddock in 4X . . . . .	122
4.10.	Haddock in 5Zj and 5Zm . . . . .	124
4.11.	Pollock in 4VWX & 5Zc . . . . .	126
4.12.	Redfish in the Gulf of St. Lawrence & Cabot Strait (4RST+3Pn (January-May) + 4Vn (January-May)) . . . . .	128

---

## GROUND FISH STOCK STATUS REPORT

### Introduction

This report presents the results of groundfish stock assessments for the Canadian Atlantic for 1993. Stock assessments experts from the four DFO Atlantic regions and Headquarters have peer reviewed the assessments. Their report will be published shortly in the Canadian Technical Report of Fisheries and Aquatic Sciences series and it will be available from DFO Regional Offices.

Sections 1, 2 and the graphs from the present report are extracts from the full report while Section 4 is new. Section 1.1 is a global overview of groundfish stock status for the Atlantic Zone, while sections 1.2 to 1.4 are regional overviews for Newfoundland, the Gulf of Saint Lawrence and Scotia-Fundy respectively. Section 1.5 is an overview of climatic and hydrological conditions in 1992 compared with average conditions. Section 2 presents one page summary sheets for each stock similar to those produced by the Northwest Atlantic Fisheries Organization (NAFO) and the International Council for the Exploration of the Sea (ICES). The graphs are numbered to correspond with the numbers of the summary sheets. The first line of the tabular information on each summary sheet - Reference Level - refers to the advice that was provided by the former Canadian Atlantic Fisheries Scientific Advisory Committee (CAFSAC) for that year. Most of the time, CAFSAC provided catch advice at the  $F_{0.1}$  reference level, but other approaches have been taken, e.g. the 50% rule. Section 4 contains descriptive narratives for cod, haddock, pollock, and Gulf of St. Lawrence redfish stocks in the same order as that of Section 2 and of the graphs.

As was done by former CAFSAC, it is expected that the data on which the assessments are based as well as technical details on the analyses will be documented in research documents that will be publically available. Any comments on the present document should be addressed to your Regional Director of Science as indicated below:

Newfoundland/Terre-Neuve:	Larry Coady (709-772-2028)
Scotia-Fundy:	Stephen MacPhee (902-426-3492)
Gulf/Golfe:	John Loch (506-851-6257)
Québec:	Jean Boulva (418-775-0555)

### **1. Overview of Groundfish Stocks**

#### **1.1. General Overview of Commercially Exploited Groundfish**

The mortality rates of the cod, haddock, pollock and many flatfish resources on the Canadian Atlantic coast have recently reached very high values and stock sizes are currently low. Less than 50% of those fish of recruited age that are present at the beginning of a year are still alive at the end of the year. The catch depends on two or three age-groups at a young age while these species could easily live up to 20 years with many more ages contributing to the catches. The fisheries are very dependent on recruiting year-classes and the fish are harvested at a rate considerably greater than their growth rate. This means that biomass is declining steadily with no hope of sustained increase at current high mortality rates. Adult

biomasses are either the lowest observed or very close to it. In all cases the estimated fishing mortality rate is substantially higher than the target rate of  $F_{0.1}$ .

Fishing mortalities in excess of the target have been noted since at least 1987. At that time, stock sizes were high and recruitment appeared to be average or better; there was no apparent urgency to reduce fishing mortalities abruptly to  $F_{0.1}$  from one year to the next. The 50% rule was therefore introduced to gradually achieve the target of  $F_{0.1}$ . This was not successful. Fishing mortalities have continued to increase and stocks have continued to decline to reach their current historical minima.

A number of factors are responsible for the current state of the stocks. A comparison of biomass trends among cod stocks shows significant correlations ( $p < 0.05$ ) among northern stocks (2J3KL, 3Ps, 3Pn4RS, 4T-4Vn, 4VsW) which are different than the trends for southern stocks (4X and 5Zjm). Year-class survival, defined here as the abundance of a year-class when it enters the fishery divided by the spawner biomass that produced it, in the northern stocks in the mid-to-late 1980s has been considerably lower than in previous years. This implies that the mortality between the time the eggs were produced and the time the recruits enter the fishery has increased, perhaps because of ocean climatic conditions, predation, competition, disease, or fishing (discarding). As a result, there have been several below average year-classes produced in the 1980s, with only the 1987 year-class showing average or slightly above average strength. Growth rates have also been low. The geographical distribution of many fish stocks is now considerably smaller than in previous years making them more vulnerable to fishing. Finally, total mortality rates (fishing+natural) have been high and have increased in recent years as the stock biomasses have decreased.

TACs, in the vast majority of cases, have been set based on scientific assessments, but these have generally overestimated potential catches. This is partly due to methodological deficiencies, not unique to Canadian fisheries science, such as the inability to predict future weights at age and recruitment which have both been declining almost steadily over this period. However there are also serious problems with the data that have been used. It is widely accepted that misreporting, dumping and discarding have been major problems in groundfisheries from at least 1985. The severity of misreporting, dumping and discarding has probably decreased in recent years as a result of better enforcement, but it still existed in 1992 and remains unquantified. The scientific assessments are critically dependent on the accuracy of catch data. Inaccuracies in reported catches have therefore caused major problems in assessing the size of the stocks.

Fishing is not the only cause of mortality. The sudden decrease in biomass estimates from research surveys observed from one year to the next in several cod and flatfish stocks cannot be attributed entirely to fishing. Changes in migration and shrinking geographical distributions, increases in natural mortality because of harsh climatic conditions, combined with poor feeding, predation by seals and other predators or competition with them are additional possible causes of increased mortalities. Given these added causes of mortality, the remaining stocks should be given as much protection as is possible in order to take advantage of better survival conditions when they occur.

The immediate and medium term prospects are poor. Recent year-classes appear to be weak and will therefore not contribute substantially to stock rebuilding. Even if the 1992 year-classes in those stocks were to be strong, they would not make significant contributions to spawning until 1997 at the earliest. Stock rebuilding will be slow and it will depend on future recruitment which will be influenced largely by climatic

conditions. However, even if nature were to produce good recruitment, this would not lead to sustained rebuilding unless fishing mortality is decreased substantially and permanently.

Controlling catches is a necessary prerequisite to reducing fishing mortality, but it is not sufficient on its own. It is now widely accepted (for example, in the North Sea and in New Zealand) that attempting to reduce fishing mortalities only by controlling catches, without some direct control on the fishing effort exerted will be unsuccessful in fisheries with severe overcapacity problems such as those of the Canadian Atlantic coast. The Georges Bank cod and haddock fisheries are good examples of the potential to exert fishing mortality; in 1989, the mobile gear fleets fished for only one month and this was sufficient to exceed  $F_{0.1}$ . The necessary drastic reductions in fishing mortalities can only be achieved by substantially decreasing fishing effort and these reductions need to be permanent. As stocks recover, catches will increase and there will be pressure from the industry to increase fishing effort. However, these pressures will have to be resisted if the benefits of an  $F_{0.1}$  management strategy are to be realized.

Decreasing the fishing mortality however does not mean that the stocks will increase forever. There will still be variability in year-classes and stocks will still fluctuate. However, dangerously low stock sizes such as those currently estimated for our Canadian Atlantic groundfish resources will be less likely to happen.

The principal index of abundance used to paint the grim picture above comes from the research vessel surveys DFO conducts to estimate biomass. These surveys are statistically designed, similar to opinion polls or tree abundance estimation in forestry, to provide unbiased estimates. However a number of factors may influence the results of any one year quite importantly. The results are notably variable from one year to the next, with some years overestimating abundance while others underestimate it. It is therefore possible that the stocks could be higher than described in this document, although there is no question that the stocks are very low.

## **1.2. Overview of Commercially Exploited Groundfish on the Newfoundland Shelf and on the Grand Banks**

The groundfish fisheries in the waters around Newfoundland exploit three main species groups: the gadoids (mainly cod with some haddock, pollock and hake), the flatfishes (American plaice, yellowtail flounder, witch flounder, Greenland halibut and Atlantic halibut) and the others consisting of species such as redfish and grenadiers. The relative importance of the different species and stocks has varied over time, but recently cod, American plaice, yellowtail flounder, witch flounder, Greenland halibut and redfish have been the most important.

Of these, cod has historically dominated the catches. Most important has been the Div. 2J3KL or "northern" cod stock but important cod fisheries also take place on the southern Grand Banks (Div. 3NO stock) and off the south coast (Subdiv. 3Ps stock). Cod catches from all of these areas gradually declined after peaking in the 1960s. In 1976, the last year before extension of jurisdiction, catches were 6,000t from 2GH, 214,000t from 2J3KL, 24,000t from 3NO and 37,000t from 3Ps. Although some of the reduction was due to quota management through ICNAF, the declines generally reflected stock reduction because of overfishing. Since extension of jurisdiction, the trajectories of the stocks have shown both similarities and differences. The resource in Div. 2GH has almost disappeared based on recent survey estimates (1991). A number of

possible causes have been put forward to explain the dramatic decline in 2J3KL cod. Many have variously blamed the decline on the Canadian offshore trawler fleet (destroying habitat, interrupting spawning, excessive dumping and discarding), the foreign fishery outside 200 miles, gillnets, cod traps, seals and the environment. It is currently believed that all of these may have contributed, in part, to the decline. It is not possible, however, to determine the relative importance of each factor. It is also not clear when the decline took place. Evidence from various surveys and fisheries may indicate that the decline occurred during the first half of 1991, but the earlier decline in biomass in the more northern areas, in 2J and perhaps in 2GH may suggest that events began as early as the late 1980s. On the Grand Banks (Div. 3NO), the decline in recent years is thought to be due to a combination of factors. There were a number of years of poor year-classes during the mid-1980s. Beginning around 1986, total catches far exceeded TACs due to foreign catches outside 200 miles on the "tail" of the Grand Banks. The problem of overfishing is exacerbated by the fact that these foreign fisheries are taking very high numbers of small fish probably as a result of the use of undersized mesh in cod ends. In Subdiv. 3Ps, survey estimates fluctuated considerably between years but gradually increased until about 1988 (85,000t) before declining somewhat. The 1992 survey results suggested a decline to only 16,000t and the 1993 results were 12,000t and 7,800t from the February and April surveys respectively. With settlement of the boundary dispute, French catches dropped from about 16,000t in 1991 to only 7,000t in 1992. There has been no French catch to date in 1993. This stock is considered to be at a low level, primarily due to high fishing mortalities in recent years.

Of the flatfish stocks, American plaice on the Grand Banks (Div. 3LNO) is historically the most important. The 1992 biomass estimate from surveys is the lowest in the series. As with cod on the Grand Banks, foreign catches outside 200 miles have been greater than their allocations since 1986, and they have caught smaller fish than taken in the Canadian fishery. This has resulted in exploitation rates exceeding reference levels. There are however, indications that the declines in biomass in Div. 3L are greater than can be explained by the fishery alone. It is unknown if this is related to factors contributing to the decline in 2J3KL cod or not. American plaice fisheries also take place in SA2+Div. 3K, and Subdiv. 3Ps. Research vessel survey results indicate that through the 1980s, the greatest proportion of biomass was in Div. 2J where it peaked in 1983 then gradually declined thereafter. In Div. 3K, biomass was stable until about 1987 then declined. Estimates in the 1990s from both divisions continued to decline, and the 1991 and 1992 estimates were only 12,800t and 5,500t respectively. The observed declines cannot be attributed to fishing mortality alone. Similar to 2J3KL cod, non-fishery related factors are probably contributing to the observed declines, although these cannot be quantified at present. In Subdiv. 3Ps, survey estimates of trawlable biomass fluctuated through the 1980s but there has been a gradual and systematic decline since about 1989, and the two estimates from the 1993 surveys are the lowest observed. Although fishing mortality has probably been above  $F_{0.1}$  in recent years, it is not believed that catches in the range of 2,500 - 5,000t could be fully responsible for declines of about 90% (from surveys) since 1986-1988. As with other American plaice stocks around Newfoundland, it appears that non-fishery related factors may be contributing to the observed declines.

The only significant fishery for yellowtail flounder is on the Grand Banks (Div. 3LNO). After remaining stable through most of the 1980s, biomass as estimated from Canadian surveys, steadily declined and in 1992 was only about one third that estimated from the 1985 and 1986 surveys. Until fishing effort is curtailed, it is not expected that this resource will increase significantly.



Witch flounder fisheries take place in Div. 2J3KL, Div. 3NO and Subdiv. 3Ps. Biomass estimates from surveys peaked in Div. 2J in 1986 but declined during the more recent period. In Div. 3K, estimates were stable through the early 1980s (about 30,000t) but declined subsequently. The total estimated biomass in these two divisions in 1992 was only 1435t. In Div. 3L, estimates were between 6,000 - 7,000t until 1988 but declined to only 1,500t in 1992. In 1992, the stock was at the lowest level ever observed. As with other stocks in the area, current fishing effort cannot account for the observed declines in biomass. On the Grand Banks (Div. 3NO) survey estimates of biomass show considerable fluctuation over the time series, but are generally lower now than in the mid-1980s. Whether this indicates a decline in stock size, or a movement of the fish to deeper water outside the survey area is unclear. Biomass estimates from surveys in Subdiv. 3Ps have fluctuated substantially between years, but there does not appear to be any long term trend in the estimates. The fluctuations may be the result of some portion of the stock being distributed in deeper water outside the survey area. Possible impacts of the fishery cannot be determined.

It is currently believed that Greenland halibut in the northwest Atlantic (with the exception of those in the Gulf of St. Lawrence) constitute one stock extending from Davis Strait (SA0 + 1) to around the Grand Banks (SA3). Results of surveys to Div. 2GH in the late 1980s indicated that the biomass had decreased by about 50%. The biomass in Div. 2J3K also declined by about 50% between 1987 and 1990. The TAC was therefore lowered to 50,000t in 1990. The estimate from the 1991 survey was only 55,000t. The observed declines in Greenland halibut in the northern areas cannot be explained by the fisheries. It is possible that the fish have redistributed to deeper water, and they may have moved further south and outside 200 miles where they have become available to the foreign fleets. At present there are no data to suggest that this foreign fishery is being prosecuted on a separate stock, and the high catches of recent years from this fishery are cause for concern.

There are four stocks of redfish in the Newfoundland area; SA2 + 3K, Div. 3LN, Div. 3O and the newly defined Laurentian Channel stock. In SA2 + 3K, survey estimates of biomass reflect a decline in the size of the stock. Estimated biomass declined from over 100,000t in the early 1980s to only about 2,000t in 1992 in Div. 2J. In Div. 3K, the decline over the same period was from over 200,000t to only 1135t in 1992. There can be no optimistic outlook for this resource until about 9-10 years after good recruitment occurs. In Div. 3LN, much of the resource is distributed outside the 200 mile limit in both 3L and 3N. There are indications that the foreign fishery continues to be excessive, and concern exists that this stock will be rapidly depleted in a short time. Because of rough bottom in much of Div. 3O where redfish could be caught, it is difficult to carry out trawling and the fleets are restricted to shallower water where smaller fish reside. These fish are unsuitable to the Canadian processors although acceptable to the foreign fleets which fish in the area outside 200 miles. Little is known about the status of this resource. The Laurentian Channel redfish stock was recently defined based on evaluation of available data from the fisheries and research in the area. Estimates of biomass in Div. 3P have fluctuated considerably over the period of surveys, but there are no long term trends in the data. There is no evidence to suggest that fishing pressure is excessive on this stock, and the size of the resource should fluctuate in the future with recruitment levels. Because new recruitment will not reach the fishery until 1997-1998, biomass and catch rates are expected to decline until then.

In the Newfoundland area, groundfish stocks can be divided into two general groups. In the areas south of Div. 3L, they appear to be primarily responding to fishing pressure. With the possible exception of Subdiv. 3Ps American plaice, all declines can be linked to excessive fishing; either Canadian or foreign. The

---

status of the various resources is only changing in parallel for those stocks subjected to this pressure. Trends in other stocks appear to be independent. Of particular concern is the effort being exerted outside 200 miles on the various Grand Bank stocks. All of these are important to Canadian interests, and the current moratorium on 2J3KL cod magnifies this importance. The outlook for these stocks cannot be improved unless the excessive fishing pressure is curtailed.

In the more northern areas (Div. 3L and north), the situation is less clear. While it can be argued that fisheries have affected the resources in these areas, they alone cannot account for the observed declines that are occurring across all groundfish species. For some of these species (for example, cod) the decline may have been abrupt, but there are indications of changes taking place earlier. For example, the reduction in biomass appears to have progressed from Div. 2J (and possibly 2GH), to Div. 3K to Div. 3L. Condition factors of cod began declining in 1990. For other species, the declines seem to have been progressive through the 1980s. Survey and fishery data also indicate that many of the species are now distributed further offshore and in deeper water than previously. The reasons for this are unknown. Although the 1981 year-class of redfish was relatively strong throughout all the rest of the northwest Atlantic, this was not the case in Div. 2J3K and northern 3L.

During the 1990s, sudden declines were also observed in the capelin biomass. Offshore acoustic surveys consistently failed to detect large concentrations beginning in 1990 although information from the inshore fishery suggests that the decline in biomass may not have been as precipitous as suggested by the offshore data. The abundance of harp seals has increased, but as is noted elsewhere in this report, no clear assessment of the harp seal's impact on cod can be made at this time although it can be hypothesized that increasing harp seal abundance will have an increasing impact.

All of these observations are coincidental with a gradual cooling trend in the area through the 1980s. In 1991, the ice cover was the greatest observed in 40 years, and the cold intermediate layer (CIL) was more extensive than had been observed previously. The impact of these changes on the biota of the area is unclear, and especially uncertain are the possible impacts on species interactions (both plant and animal).

For these northern resources, it is unclear if decreased or complete cessation of fishing will result in improvements in stock status. No meaningful predictions concerning the future of these resources can be made until the processes at work are better understood.

### **1.3. Overview of Commercially Exploited Groundfish in the Gulf of St. Lawrence**

The Gulf of Saint Lawrence groundfish fishery is dominated by three species: cod north and south of the Laurentian Channel (stocks of 3Pn4RS and 4TVn [Jan.-Apr.]), redfish in the deep waters of the Laurentian Channel, and to a lesser extent, American plaice in the southern Gulf. There are smaller localized directed fisheries for Greenland halibut in the St. Lawrence estuary and western Gulf, witch along the southwest coast of Newfoundland and 4T, white hake in Northumberland Strait, and winter flounder in inshore areas. Both cod and redfish are migratory and sustain winter fisheries in the Cabot Strait area and summer fisheries within the Gulf of St. Lawrence.

The water temperature in the Gulf of St. Lawrence was substantially cooler from 1990 to 1992 than in the mid-1980s. Bottom temperature in the southern Gulf in September were warmer in the 1970s and have been cold since the early 1980s. Since 1990, cold waters coming through the Strait of Belle-Isle have occupied increasingly large areas in inshore zones of the northern Gulf. The deep Atlantic waters moving through Cabot Strait were colder (reduction from about 6° to 4° C) bringing about a cooling of the deep waters in the Gulf. Ice coverage in recent years has been much more extensive than normal. This has considerably delayed the spring fisheries for cod, both in the northern and southern Gulf.

The two cod stocks in the Gulf have fluctuated in harmony with the other "Northern stocks" (i.e. northern cod, Saint-Pierre Bank cod, and eastern Scotian Shelf cod). After a period of high abundance in the 1960s, the two stocks declined to very low levels in the mid-1970s, increased to very high level of abundance in the mid-1980s, to decline very sharply since then to the lowest levels on record. The exploitation rate on these stocks increased gradually throughout the 1980s, and has increased abruptly in the 1990s. In recent years, with the decrease in growth rate and lower abundance of larger cod, the fishery has been characterized by large catches and discards of small fish (less than 41 cm). Recruitment for the two stocks has been well below average since the mid-1980s, despite high levels of spawning biomass at that time. This means that fewer recruits are produced per unit of spawning biomass. The low recruitment, combined with slower growth has contributed to the decline in biomass of cod in the Gulf of St. Lawrence.

The redfish "stock" was recently redefined to take into consideration the migration into the Cabot Strait area in the winter. Two species comprise the stock, but the dynamics of these two species are not well understood. Gulf redfish seems closely related to Laurentian Channel redfish (3P4V). The history of the stock, and hence of the fishery, is dominated by the appearance of very large, sporadic year-classes (late 1950s, early 1970s, 1982, and now 1988). The catches of redfish have a tendency to fluctuate as these strong year-classes move through the population. The large 1982 year-class is now fully recruited to the fishery and it has allowed catches and catch rates to be very high since 1990. The next visible year-class will recruit to the fishery in 1997-1998, but as this year-class recruits, the species composition of redfish in the Gulf should shift from *Sebastes mentella* to *S. fasciatus*.

The flatfish stocks, with the exception of Greenland halibut, do not seem to show these large fluctuations. After a period of relatively high abundance in the 1960s and early 1970s, the exploited flatfish stocks declined to somewhat lower levels in the recent past but have remained relatively stable since then. The fishery for Greenland halibut was characterized by large fluctuations (5 fold differences between the lows and the high over 5 years), a consequence of highly irregular recruitment and very high exploitation that does not allow the persistence of the incoming year-class in the population.

American plaice abundance varies on a much longer time scale, and for a time, appeared to be inversely related to cod abundance. American plaice abundance is now lower than average and this fishery is plagued with a major discarding problem.

#### **1.4. Overview of Commercially Exploited Groundfish on the Scotian Shelf and on Georges Bank**

The Scotian Shelf and Georges Bank groundfish fisheries are dominated by cod, haddock and pollock. In addition, important fisheries for flatfish, (plaice, yellowtail, witch and winter flounder), Atlantic halibut, redfish

and silver hake are conducted in the Region (the silver hake fishery is mostly by foreign vessels). The area can be considered as two major ecosystems, the eastern Scotian Shelf and the southwest Scotian Shelf/Georges Bank area.

Since 1970, groundfish stock abundance in these two ecosystems has increased to a peak in the mid-1980s and thereafter declined to the current historical low levels. These changes have been particularly pronounced on the eastern Scotian Shelf. This year's assessment of the 4VsW cod resource is considerably more pessimistic than last year's, with downward adjustment of the 1985-90 year-classes and estimation of the highest fishing mortalities recorded. The mature biomass which was high in 1985, by 1992 had declined to the lowest levels observed. The status of this resource is precarious and there are concerns about its long term viability if fishing mortality is not reduced.

The analysis of the Sydney Bight cod (4Vn May to December) resource focused on confirming that fish present in the area during December were of 4T origin. The definition of the management unit should be adjusted accordingly.

Present estimates of eastern Scotian Shelf haddock (4TVW) spawning biomass are lower than last year with concomitantly lower probability of average or better recruitment. The population size structure has narrowed to the point where a single year-class, the 1988 year-class, dominates the population. Fishing mortality rates on the fully exploited size ranges are presently very high and, if continued, will slow or prevent the rebuilding of spawning biomass. Year-classes after 1988 have been below average.

Flatfish resources (plaice, yellowtail and witch) while under quota management, have been under increasing pressure since the introduction of individual quotas in 1991. In 4VW, yellowtail and plaice abundance are either relatively stable or increasing while that for witch is decreasing. Atlantic halibut abundance of older fish has fallen steadily since 1988.

It is evident that for most of the eastern Shelf resources, recruitment has declined since the mid-1980s. While a reduction in spawner biomass may be partially the cause, the low survivorship of ages 1-3 cod in 4VsW since 1985 indicates that other factors are involved. Ocean climate changes may be implicated. There is considerable evidence to show that the oceanographic regime on the Shelf has changed in recent years. During 1992, sea surface temperatures were generally below normal throughout most of the year. An analysis of near-bottom temperatures suggests that the region is in a period of ocean cooling with particularly cold conditions in 4V. In this area, summer bottom temperatures have declined steadily since 1978 to reach an all time low in 1992. These climate changes have been accompanied by an increase in the abundance of capelin, a cold water species. Grey seal abundance has also increased markedly since the 1960s due to sustained high pup production. While this increase has likely had some impact on eastern Shelf populations, the extent of this cannot be determined. Suspected high discard rates in the fishery may also have decreased survivorship of ages 1-3 cod.

The cod and haddock on the southern Scotian Shelf and on Georges Banks grow faster and recruit to the fishery at an earlier age than those on the eastern Scotian Shelf. Since the early 1970s, high exploitation rates mean that fish are harvested at a young age. This makes these fisheries extremely dependent on incoming recruitment. As a result, landings have fluctuated greatly with changes in recruitment. Specifically, the 4X cod and haddock fisheries are presently dependent on only 1 or 2 year-classes, with biomass either

declining or expected to decline due to recent poor recruitment and high exploitation rates. Misreporting of catches by management unit (e.g. 5Z haddock catches reported as 4X haddock) continues to occur, though apparently to a lesser degree than in the 1980s.

The only positive sign is an indication, based on Georges Bank cod, of an above-average 1990 year-class. The Georges Bank cod and haddock stocks are severely depleted as excess fishing capacity has been channelled to those stocks when individual quotas were introduced on the Scotian Shelf in 1991. The transboundary nature of these resources has complicated management. A study of migration patterns suggests that for haddock in particular but also for cod, there would be benefits to Canada if it were to unilaterally adopt conservation measures. However, considering the presently very low stock sizes, stock rebuilding would require joint management.

The Scotian Shelf pollock has been declining as the year-classes which followed the exceptional 1979 year-class have been moderate at best. Exploitation for this species is also very high and a continued decline is forecast until better recruitment occurs.

Flatfish resources (plaice, yellowtail and witch) in 4X while under quota management have also been under increased fishing pressure since the introduction of individual quotas on the Scotian Shelf in 1991. Survey estimates indicate that witch flounder abundance is decreasing while for plaice and yellowtail, abundance is either stable or increasing slightly.

Winter flounder are currently outside the quota management system although landings in 4X are higher than for other flatfish species. Survey catch rates have increased since 1988, however being in part a coastal species, the survey only covers the offshore portion of this resource. Industry comments suggest that catch rates are declining in inshore areas. If individual quotas are introduced for flatfish, winter flounder should be included under quota management to prevent a shift of effort to non quota species or to misreport quota species. Overall the status of flatfish stocks on the Scotian Shelf cannot be assessed with present information because landings are not reported by species.

Contrary to the situation on the eastern Scotian Shelf, while recent recruitment on the southern Shelf has been low, this does not appear to be as a result of low survivorship of young fish. Sea surface and near bottom temperatures on the southern Scotian Shelf and Georges Bank were generally below normal throughout most of 1992. Also, in 1992 normal low spring salinities extended deeper into the water column and persisted longer than usual. It is not possible to relate these changes to the declines in abundance.

Overall, except for stocks such as 4X haddock, 4VW plaice and yellowtail and 4X winter flounder, all groundfish resources have declined in abundance since 1988, in some cases to historical low levels. These declines are due to a combination of recent low recruitment and high exploitation rates. Examination of stock/recruitment relationships indicates that juvenile survivorship in a number of stocks has declined in recent years, with fewer recruits being produced per unit of spawning biomass. Some of this may be due to seal predation or discarding by the commercial fishery. However, the dramatic changes in the ocean climate likely also play a large role.

### 1.5 Environmental Conditions

The Fisheries Oceanography Subcommittee reviewed the ocean climate condition in the northwest Atlantic at its March, 1993 meeting. This involved analysis of broad-scale environmental data with emphasis on atmospheric and oceanographic conditions in 1992, analysis of hydrographic conditions from each region during the 1992 groundfish surveys and comparison of environmental conditions in 1992 and the recent past.

#### *Labrador and Newfoundland*

In 1992, relatively cold conditions were observed in the waters off southern Labrador and northern Newfoundland. A cold Arctic air mass covered the region during the winter of 1991-92 which promoted early ice growth. Strong northwesterly winds pushed the ice southward so that the areal extent of ice through most of the first three months of 1992 was above normal. The offshore limits of the ice edge matched or were near their long-term maxima through much of the winter. Ice also persisted longer than normal with new records being set for the date of the presence of the last ice in the offshore regions of northern Newfoundland. Relatively high numbers of icebergs drifted south of 48° N during the spring and summer. Air temperatures continued to remain below normal throughout the year except in the late summer and early autumn. In response to the cold air, sea surface temperatures were generally below their long-term means. At Station 27, the monthly sea surface temperature anomalies were all below normal with the largest anomalies (near -2°C) occurring in July and October. Negative temperature anomalies also persisted throughout the water column at Station 27 during most of 1992. The near bottom temperatures (175 m) were below normal for the 10th consecutive year but a slight warming was observed during the year. Salinities throughout the water column at Station 27 were typically fresher than normal in 1992. The area extent of the cold intermediate layer (CIL), defined by waters of temperature <0°C, along several transects off southern Labrador and northern Newfoundland was slightly above normal but had decreased significantly from a maxima in 1990. During the annual fall groundfish survey surface temperatures and near bottom temperatures were generally below normal. The amount of water <-1°C was less in the fall of 1992 than in 1991 but was greater than the long-term mean. In general the cold air temperatures, heavy ice and cold sea temperatures observed in 1992 are similar to the previous two years and match conditions in the early 1970s and mid-1980s. These cold conditions are related to the wintertime atmospheric circulation, and specifically an intensification and/or westward shift in the strength of the Icelandic low which generates relatively strong northwesterly winds over the Labrador Sea.

#### *Gulf of St. Lawrence, Scotian Shelf and Gulf of Maine*

Colder than normal air temperatures were also present south of Newfoundland during the winter of 1991-92. In the Gulf of St. Lawrence, the timing of the ice formation was within a week of its normal occurrence but by the end of January the ice extent was greater than normal. Ice pushed onto the northeastern Scotian Shelf in February and its areal extent exceeded the long-term median. On the Scotian Shelf and in the Gulf the ice retreat was late with new records set for the last presence of ice on the Magdalen Shallows. Sea surface temperatures on the Scotian Shelf and in the Gulf of Maine point to cold water throughout most of 1992. These reflect conditions in the upper layers (50-100 m depth) based on data from Prince 5 and Emerald Basin. In Emerald Basin, lower layer (>75m) temperatures increased dramatically over near record cold conditions last year to above normal temperatures in 1992. A similar event was observed in the deep

(200-300 m) waters in Cabot Strait. These warmer waters are believed to be related to changes in the slope waters off the continental shelf which then intruded onto the shelf during late 1991 or early 1992. In contrast, in the northern Gulf of St. Lawrence, waters of Labrador origin penetrated the Strait of Belle Isle and spilled over into the Esquiman Channel. Consequently, bottom temperatures in this region dropped by approximately 2° C between 1990 and 1992. On the Magdalen Shallows, temperature data collected during the September groundfish survey revealed colder than normal bottom waters at this time in 1992. The area of the waters on the Shallows with temperatures below 0° C was much greater than normal during the past three years. Other years of extensive cold waters were 1972 and 1984. On the northeastern Scotian Shelf, near-bottom temperatures in the summer of 1992 were also colder than their long-term means and the largest volume of cold intermediate layer water was recorded in over 20 years. Salinities at this time were typically fresher than average. Colder than normal bottom temperatures in summer were also observed off Browns Bank, southwest Nova Scotia and throughout the Bay of Fundy. On Georges Bank, temperatures recorded during the spring groundfish surveys indicated near normal bottom temperatures and salinities.

#### *Offshore*

The shelf/slope front and the Gulf stream were generally northward of their long-term mean positions during 1992.

## 2. Summary Sheets

## 2.1 COD in 2J, 3K and 3L

**SUMMARY**

Fig. 1.1a-1.1h

Year - Année	1986	1987	1988	1989	1990	1991	1992	1993	Min. <sup>1</sup>	Med. <sup>1</sup>	Max. <sup>1</sup>
Reference level/Niveau de référence '000t	266	266	293	N/A	N/A	100-215	185	<sup>2</sup>			
TAC - TPA '000t	266	256	266	235	199	190	120				
Rep.catches-Prises décl. '000t	252	235	269	253	219 <sup>3</sup>	171 <sup>3</sup>	44 <sup>3</sup>		49	278	810
Unreported catches Prises non-déclarées											
Est.discards - Rejets est.											
Tot. catches - Prises Tot.											
Tot.biomass-Biomasse Tot.											
Sp.biomass-Biomasse Rep.											
Mean - F - Moyen											
<sup>1</sup> For/Pour 1962-1992 <sup>2</sup> June 1992 - lowest possible/juin 1992, plus bas possible. <sup>3</sup> Preliminary statistics/Statistiques provisoires											

**Forecast for 1994:** Continuing fisheries (the Canadian recreational fishery and foreign catches outside the 200 mile limit) may be factors in retarding the recovery of the stock.

**Catches:** A moratorium was imposed on the Canadian fishery in July 1992. Canadian fishing in this area was severely curtailed with about 29,000t taken in 1992. However, 14,300t of cod were also caught outside of the Canadian Economic Zone in Division 3L during the first half of the year by non-Canadian vessels.

**Data and Assessment:** The principal index of abundance is an autumn research vessel survey series. From 1978 to 1990, the catch per tow has averaged about 50 fish with the 1990 catch per tow equal to the average. The catch per tow decreased to 33 fish in 1991. The decline was more pronounced for fish age 6 and older. Despite the severe reduction in fishing activity as a result of the moratorium, the catch per tow decreased further during the 1992 autumn survey to 9 fish per tow.

**Fishing Mortality:** Total mortality is estimated to be very high, above 1 in 1991 which means that more than 60% of the fish are dying each year. Under the normal assumption of constant natural mortality ( $M=0.2$ ), this would imply very high fishing mortality. However, fishing activity has not increased in the Canadian Zone so as to explain such an increase in total mortality. The fishing mortality, however, may have increased because the fish could be substantially more catchable, perhaps because of climatic conditions. Another possible explanation is that natural mortality may have increased as a result of harsh climatic conditions, poor feeding, predation by seals or competition with them, or migration out of the area.

**Recruitment:** The 1986 and 1987 year-classes are still dominating the stock despite their being less abundant than the average for corresponding age. Based on relationships between recruitment success and hydrographic variables, it is likely that the 1988 to 1991 and probably 1992 year-classes will be weak.

**State of the Stock:** The stock is in a very depressed state, probably the lowest abundance in the 20<sup>th</sup> century.

**Environmental Factors:** Climatic and hydrographic conditions in 1991-1992 off the Newfoundland shelf have been among the worst recorded for ice coverage, duration of ice, extent of the cold intermediate layer of water less than 0° C.

**Multispecies Considerations:** Capelin abundance as estimated from acoustic surveys have been very low since 1990 in these areas and the biomass of several other groundfish stocks, some very lightly exploited have also decreased markedly during the 1980s. Following the cessation of the large vessel hunt for harp seals in 1983, the abundance of the seal herd is estimated to have increased to about 3 million seals in 1990. However, the increase is likely to have continued.

**Long-term Prospects:** Catches since 1960 have averaged about 350,000t during a period of relatively high exploitation rates. Before the expansion of the fishery in the 1960s, catches have generally been in the 200,000t to 300,000t range. Given the current state of the stock, and considering that fish are normally becoming mature at about age 7, recovery of the spawning stock biomass is unlikely before the year 2000 at the earliest.



**2.2. COD in 3Ps**  
**SUMMARY**  
 Figs. 1.2a - 1.2f

Year - Année	1986	1987	1988	1989	1990	1991	1992	1993	Min. <sup>1</sup>	Med. <sup>1</sup>	Max. <sup>1</sup>
Reference level - Niveau de référence '000t	26-61	26-58	37	20.5	N/A	29-44.5	39-44.5	20			
TAC - TPA '000t	60.6 <sup>3</sup>	60.6 <sup>3</sup>	60.6 <sup>3</sup>	50 <sup>3</sup>	45 <sup>3</sup>	44 <sup>3</sup>	44 <sup>3</sup>	20			
Rep.catches-Prises décl. '000t	57	57	43	39.5	41 <sup>2</sup>	43 <sup>2</sup>	31.5 <sup>2</sup>		27	49	84
Unreported catches Prises non-déclarées											
Est.discards - Rejets est.											
Tot. catches - Prises Tot.											
Tot.biomass-Biomasse Tot. <sup>4</sup> ('000t)	200	168	144	141	139	111	81		80	168	293
Sp.biomass-Biomasse Rep. <sup>4</sup> ('000t)	60	57	49	43	36	28	24		18	58	123
Mean - F - Moyen (6+) <sup>4</sup>	.55	.66	.59	.46	.58	.70	.70		.33	.54	1.16
<sup>1</sup> For/Pour 1959-1992 <sup>2</sup> Preliminary statistics/Statistiques provisoires <sup>3</sup> This is the effective TAC which was obtained by combining the Canadian quota and the French quota of the TAC set by each party/TPA "defacto" obtenu en additionnant les quotas établis par le Canada et la France <sup>4</sup> Not calibrated, for illustrative purposes/Non ajusté, calibré pour illustration											

**Forecast for 1994:** No quantitative forecast was made. Fishing mortality, and therefore fishing effort, would have to be decreased by a factor of about 3 to correspond to  $F_{0.1}$ .

**Catches:** 1992 catches were 32,000t, markedly lower than those during 1991. The decrease was partly due to the settlement of the boundary dispute because France did not fish after July 1992.

**Data and Assessment:** Canada conducted two surveys in 1993 (February and April) to ensure that the timing of the cod migration would not impact on the estimate of biomass. Results from the two surveys confirmed the low estimate from the 1992 survey. France discontinued their surveys after 1992. Based on multiplicative analyses of catch-at-age from research surveys and the commercial fishery and on average fishing mortalities from preliminary SPA, it was concluded that fishing mortality in recent years has probably been in the range of 0.5 to 0.9. An illustrative SPA using  $F=0.70$  was conducted to demonstrate stock size trends.

**Fishing Mortality:** Results from the illustrative SPA indicate that fully recruited fishing mortalities have been greater than twice  $F_{0.1}$  since the extension of jurisdiction, and have been gradually increasing since that time. Coincidentally, there has been a gradual decline in stock size through the second half of the 1980s.

**Recruitment:** The 1993 survey results indicated that the 1987 and 1989 year-classes are relatively strong.

**State of the Stock:** The stock abundance is at about its lowest since 1978.

**Environmental Factors:**

**Multispecies Considerations:**

**Long-term Prospects:** There has been a gradual decline in stock size through the second half of the 1980s. Some decrease in the rate of decline can be expected because of recruitment of the relatively strong 1987 and 1989 year-classes. However, unless there is a considerable reduction of fishing effort, longer term increases in stock size cannot be anticipated at this time.

## 2.3. COD in 3Pn and 4RS

## SUMMARY

Fig. 1.3a - 1.3j

Year - Année	1986	1987	1988	1989	1990	1991	1992	1993	Min. <sup>1</sup>	Med. <sup>1</sup>	Max. <sup>1</sup>
Reference level - Niveau de référence '000t	83	80.3 <sup>2</sup>	73.9 <sup>2</sup>	72	56	35	24-35	35			
TAC - TPA '000t	92.1	80.3	73.9	76.5	58	35	35	31			
Rep.catches-Prises décl. '000t	83	67	48	47	40 <sup>3</sup>	32 <sup>3</sup>	29 <sup>3</sup>		29	79	106
Unreported catches Prises non-déclarées											
Est.discards - Rejets est.											
Tot. catches - Prises Tot.											
Tot.biomass-Biomasse Tot. '000t	303	210	168	162	211	188	172	193	162	303	444
Sp.biomass-Biomasse Rep. '000t	111	87	59	62	47	34	29	46	29	99	182
Mean - F - Moyen (7-9)	0.69	0.86	0.53	0.69	0.69	0.57	0.51		0.36	0.51	0.86
<sup>1</sup> For/Pour 1974-1992 <sup>2</sup> 50% rule / Règle du 50% <sup>3</sup> Preliminary statistiques/Statistiques provisoires											

**Forecast for 1994:** Fishing at  $F_{0.1} = 0.20$  in 1994 will yield catches of about 20,000t. The total biomass would increase to 210,000t and the spawning biomass to 81,000t in 1994.

**Catches:** Peaked at 106,000t in 1983 and have steadily declined to an historic low of 29,000t in 1992. Catches since 1987 have been lower than the average for the period 1964-1992 which equals 75,000t.

**Data and Assessment:** Commercial catch rates are not considered reliable indices of abundance because of contradictory trends between fleets (work to investigate this question is ongoing). Therefore the assessment is calibrated with the results of a research survey conducted in January. The results for 1993 are the second lowest in the time series. The assessment was calibrated using ADAPT in a manner very similar to last year.

**Fishing Mortality:** Is estimated to have been about  $F = 0.50$  on fully recruited ages, substantially above the target of  $F_{0.1} = 0.2$ .

**Recruitment:** The 1971 to 1983 year-classes ranged from 61 million to 196 million. Since then, with the exception of the 1987 year-class at 140 million, year-classes have ranged between 43 million and 90 million, considerably less than during the previous decade. The 1988 and 1989 year-classes are estimated to be weak although the information on their abundance is not precise.

**State of the Stock:** This cod stock is at a very low level, probably the lowest in the last 20 years.

**Environmental Factors:** The distribution of cod (based on the research survey data) moved to considerably greater depths, from 150m in 1978 to 250m in the early 1980s, and over 450m from 1991 to 1993. Bottom water temperatures have been lower than average in 1991 and 1992.

**Multispecies Considerations:** Shrimp, snow crab, lobster, herring and mackerel abundance are generally high in this area. Grey seal abundance in the Gulf of St. Lawrence is increasing albeit at a rate slower than on Sable Island. A component of the harp seal herd breeds in the Gulf of St. Lawrence.

**Long-term Prospects:** Under conditions of average productivity, cod in this area should yield in the order of 80,000t per year. Biomass is expected to increase in the near future as a result of the average 1986 and 1987 year-classes. However considering the current low abundance and weak incoming recruitment, sustained stock rebuilding is likely to be slow.

**Special Comment:** This assessment is currently entirely dependent on the research vessel survey conducted in January which could cease to be conducted after 1994. However this may be counteracted by the addition of new indices of abundance. The index fishers program started in 1990, the summer survey, and the new commercial catch rate series based on individual vessels may show some promising avenues.

**2.4. COD in 4T and 4Vn (Jan.-Apr.)**  
**SUMMARY**  
 Figs. 1.4a - 1.4l

Year - Année	1986	1987	1988	1989	1990	1991	1992	1993	Min. <sup>1</sup>	Med. <sup>1</sup>	Max. <sup>1</sup>
Reference Level - Niveau de référence '000t	60	24	49	55	53	48-53	43	13-15			
TAC - TPA '000t	60	45	54	54	53	48	43	13			
Rep.catches-Prises décl. '000t	67.2	53.2	54.6	55.4	54.5 <sup>2</sup>	47.4 <sup>2</sup>	38.7 <sup>2</sup>		22.2	56	104.5
Unreported catches Prises non-déclarées											
Est.discards - Rejets est. '000t						3.0	2.6				
Tot. catches - Prises Tot.											
Tot.biomass-Biomasse Tot. '000t	324	279	213	196	184	153	119	102	102	279	491
Sp.biomass-Biomasse Rep. '000t	249	219	181	154	121	103	83	63	63	189	427
Mean - F - Moyen (7+)	.66	.48	.61	.84	.97	.95	.87		.28	.54	1.39
<sup>1</sup> For/Pour 1950-1992 <sup>2</sup> Preliminary statistics/Statistiques provisoires											

**Forecast for 1994:** Fishing at  $F_{0.1} = 0.20$  in 1994 will yield catches of about 8,000t. Both the total biomass and the spawning biomass would remain stable, close to the lowest values observed.

**Catches:** Catches from 1950 to 1992 have averaged 56,000t. The 1992 catches of 38,666t (4,358t of which were taken outside of the stock area, primarily in unit area 4Vsb) were lower than the TAC because fixed gear did not catch their allocation. The average size in the catch is small and very few fish greater than 50 cm (about 20 inches) have been caught in recent years. Persistent ice during the spring of 1992 delayed the fishery until mid-May in 4T.

**Data and Assessment:** The average catch per tow during the September 1992 survey was the second lowest since 1971 when the surveys started. The 1992 survey was done using a different vessel and results were adjusted to take into account changes in vessel fishing power. The commercial catch rates for otter trawlers increased slightly in 1992. The assessment was made using Sequential Population Analyses calibrated with ADAPT as in previous years, but also using the Laurec/Shepherd hybrid and the Extended Survivor methodology (XSA).

**Fishing Mortality:** Fishing mortality varies depending on the assessment method used, but it is likely high, quite substantially above the target of  $F_{0.1} = 0.2$ .

**Recruitment:** All indices and all assessment methods used indicate that recruitment since the 1982 year-class has been below average. The 1988-1990 year-classes appear to be particularly weak, much lower than the previous smallest year-class.

**State of the Stock:** This stock is currently at its lowest observed level in recent history since about 1950. Weights-at-age remain below average and there are no signs of improving recruitment.

**Environmental Factors:** The average temperature in which cod are found during the research survey is considerably lower during the 1980s than during the 1970s. The period of low temperature also corresponds to the period during which average weights have been lower.

**Multispecies Considerations:** Snow crab, lobster, herring and mackerel have been and are probably still relatively abundant in this area.

**Long-term Prospects:** Given average conditions for recruitment and weights-at-age, this resource could produce in the order of 50,000t in the long term. Cod are first recruited to this fishery at age 3, but they make their greatest contribution to the stock at age 5 to age 7. Considering that the 1989 and 1990 year-classes appear to be weak, spawning stock biomass is not expected to recover by any significant amount until recruitment improves and the fish become mature. Recovery after 1995 is dependent on future recruitment on which there is at present no information.

**2.5. COD in 4Vs and in 4W**  
**SUMMARY**  
 Figs. 1.5a - 1.5n

Year - Année	1986	1987	1988	1989	1990	1991	1992	1993	Min. <sup>1</sup>	Med. <sup>1</sup>	Max. <sup>1</sup>
Reference level - Niveau de référence '000t	36	40	32	33.2	35	21-35	35.2	11			
TAC - TPA '000t	48	44	38	35.2	35.2	35.2	35.2	11			
Rep.catches-Prises décl. '000t	52	46	38	37	30 <sup>2,4</sup>	24 <sup>2,4</sup>	25 <sup>2,4</sup>		10	52	80
Unreported catches Prises non-déclarées											
Est.discards - Rejets est. '000t	.3	.3	.3	.3	.3	.3	.3				
Tot. catches - Prises Tot.											
Tot.biomass-Biomasse Tot. '000t	175	136	110	101	86	67	50	37	37	151	243
Sp.biomass-Biomasse Rep. '000t	100	84	71	52	33	19	18	14	10	59	102
Mean - F - Moyen (7-9)	0.44	0.53	0.66	0.55	1.31	0.73	1.56		0.22	0.46	1.56
<sup>1</sup> Catches/Prises: 1958-1992; Biom. & F; 1970-1992 <sup>2</sup> Adjusted for 4T / Ajusté pour 4T <sup>3</sup> Discards reported to have been high but not quantified/Rejets ont été élevés mais non quantifiés <sup>4</sup> Preliminary statistics/Statistiques provisoires											

**Forecast for 1994:**  $F_{0,1}$  catches in 1994 are in the order 2,500t.

**Catches:** Discards are reported to have been high in some years, but they have not been quantified. Reported catches have been maintained close to the TAC partially because of the harvest of 4T-4Vn cod in 4Vsb in the winter. Historically, longlines have taken larger fish than mobile gear. In 1992, however the size composition for both gear was very similar with very few fish larger than 70cm and most of the catch in the 45 to 60 cm range. After the mobile gear closure in 4W to protect juvenile haddock came into effect, there has been a marked increase in longline catches of cod in the closed area.

**Data and Assessment:** The sequential population analysis was calibrated with the results of a spring survey (1979-1992) and a summer survey (1970-1992). The spring 1992 survey was the lowest ever with less than 200 fish taken during the entire survey. The July 1992 survey was higher than the 1991 value, but still low. The 1993 spring survey was similar to the July 1992 summer value but was not used in the calibration.

**Fishing Mortality:** Total mortality is estimated to have increased substantially over the 1980s and was above 1.0 in 1992, implying that more than 60% of the population is dying each year. With a constant natural mortality rate of  $M=0.20$ , this would mean that fishing mortality is substantially above the  $F_{0,1}=0.20$  target. A shrinking of the distribution may have increased catchability and fishing mortality per unit of fishing effort.

**Recruitment:** Has been substantially below average since 1984. The 1988 to 1991 year-classes, according to preliminary estimates are small.

**State of the Stock:** The spawning stock biomass and fishable biomass are at the lowest levels seen since 1970. However, small fish are still seen in the surveys. If the 1993 TAC of 11,000t is taken the spawning stock biomass will continue to decline. At such low biomasses and given the recent poor survivorship of juveniles, any recovery will be slow.

**Environmental Factors:** Bottom water temperatures have decreased markedly since the early 1980s, particularly in 4Vs, somewhat in parallel with decrease in recruitment, although no causes effect has been demonstrated.

**Multispecies Considerations:** Grey seal population abundance has increased steadily since the early 1960s and pup production has been increasing since the early 1960s at about 12% per year. Although it is not presently possible to quantify the effects of grey seals on cod, they are certain to exist either directly by predation or indirectly by competition. Grey seal stomach analysis from this and other areas show that cod can be an important food item, with the largest proportion in the stomach being less than 30cm.

**Long-term Prospects:** Cod in this area are first caught at about age 3, but they do not become mature until about age 6. This means that even if the 1992 year-class were to be strong, it would not result in a spawning stock increase until 1998. Stock rebuilding will therefore be slow.

## 2.6. COD in 4X SUMMARY

Figs. 1.6a - 1.6g

Year - Année	1986	1987	1988	1989	1990	1991	1992	1993	Min. <sup>1</sup>	Med. <sup>1</sup>	Max. <sup>1</sup>
Reference level - Niveau de référence '000t		13	9	12.5	12	20	20	26			
TAC - TPA '000t	20	17.5	14	12.5	22	26	26	26			
Rep.catches-Prises décl. '000t	20	19	20	20	24 <sup>2</sup>	28 <sup>2</sup>	26 <sup>2</sup>		12.2	21.2	35.5
Unreported catches Prises non-déclarées											
Est.discards - Rejets est.											
Tot. catches - Prises Tot.											
Tot.biomass-Biomasse Tot. '000t	58	65	77	80	87	83	74	68	58	80	113
Sp.biomass-Biomasse Rep. '000t	46	42	53	58	75	68	56	50	42	62	95
Mean - F - Moyen (4-6)	0.55	0.49	0.58	0.40	0.45	0.48	0.60		0.27	0.45	0.76
<sup>1</sup> For/Pour 1948-1992. <sup>2</sup> Preliminary statistics/Statistiques provisoires											

**Forecast for 1994:** If the TAC of 26,000t in 1993 is taken,  $F_{0.1}$  catches in 1994 would be about 7,000t.

**Catches:** Catches have been irregularly cyclical since 1960 with peaks in 1968, 1982 and 1991. They have averaged about 20,000t over this period.

**Data and Assessment:** The assessment was done using sequential population analyses calibrated with ADAPT using the results of a July research vessel survey. The 1992 survey biomass was 10% lower than in 1991.

**Fishing Mortality:** F has been consistently above twice  $F_{0.1}$  and has been increasing since 1989.

**Recruitment:** The strong 1985 and 1987 year-classes have made most of their contribution to catches. Other year-classes during the 1980s were generally below average. Incoming year-classes were assumed to be average.

**State of the Stock:** This stock is rapidly declining from very high abundance in 1990. Although stock biomass shows distinct irregular cycles, there is a general downward trend.

**Environmental Factors:**

**Multispecies Considerations:**

**Long-term Prospects:** Catches since 1948 have averaged about 20,000t, but the average for 1960 to 1992 was higher. Decreasing maxima in biomasses may be indicative of decreasing productivity, perhaps because of continued high exploitation. Yield has been foregone due to high fishing mortalities which do not permit the growth potential to be realized. The fluctuations in biomass and catch could be dampened by reducing exploitation rates and allowing each year-class to contribute to the fishery for a greater duration. This would make the fishery less susceptible to recruitment variations.

## 2.7. COD in 5Zj and in 5Zm

**SUMMARY**

Figs. 1.7a - 1.7b

Year - Année	1986	1987	1988	1989	1990	1991	1992	1993	Min. <sup>1</sup>	Med. <sup>1</sup>	Max. <sup>1</sup>
Reference level - Niveau de référence '000t	11	12.5	9.9	8	8	11-22	15-22	14			
TAC - TPA '000t	1 <sup>2</sup>	12.5 <sup>2</sup>	12.5 <sup>2</sup>	8 <sup>2</sup>	-	15 <sup>3</sup>	15 <sup>3</sup>	15 <sup>3</sup>			
Rep.catches-Prises décl. '000t	14	17	21	14	21 <sup>4</sup>	20 <sup>4</sup>	17 <sup>4</sup>		12	17	26
Unreported catches Prises non-déclarées											
Est.discards - Rejets est.											
Tot. catches - Prises Tot.											
Tot.biomass-Biomasse Tot. (1+) '000t	63	71	72	64	68	57	41	29	29	62	75
Sp.biomass-Biomasse Rep. (3+) '000t	40	37	54	48	58	39	25	25	25	43	58
Mean - F - Moyen (3+)	.49	.42	.50	.34	.52	.78	.86		.34	.48	.86

<sup>1</sup> For 1978-1992 / Pour 1978-1992  
<sup>2</sup> Canadian allocation / Allocation canadienne  
<sup>3</sup> Canadian quota in the new management unit / Contingent canadien pour la nouvelle unité de gestion  
<sup>4</sup> Preliminary statistics/Statistiques provisoires

**Forecast for 1994:** All indications are that this stock has declined substantially since 1990 and that further reductions are expected if fishing continues at the present level. Given the indications that the 1991 and 1992 year-classes are well below average abundance, a catch equal to that of 1992 could result in a very high exploitation rate of the 1990 year-class (over four times the  $F_{0.1}$  reference). This year-class will have to support both the 1993 and 1994 fisheries.  $F_{0.1}$  catches in 1994 would be less than 2,000t.

**Catches:** Landings in 1992 were the lowest since 1987 for the USA while Canadian landings decreased by 2,000t compared with 1991. The 1992 landings were 16,792t, equal to the long term average of 17,000t. Canadian landings account for about 65% of the total. Canadian landings to the end March, 1993 were about 2,000t.

**Data and Assessment:** The 1993 Canadian survey shows a continuing decline and USA spring surveys also show a decline in 1992 to the lowest observed. The USA autumn survey estimate, while increasing slightly in 1992, is very low compared with other values in the series. Canadian commercial catch rates show a substantial decline since 1987.

**Fishing Mortality:** Exploitation rates were above twice  $F_{0.1}$  during 1978-1990 and about four times  $F_{0.1}$  in 1991-1992.

**Recruitment:** Preliminary estimates of the 1991 and 1992 year-classes based on research vessel surveys appear below average.

**State of the Stock:** Total and spawning biomasses are the lowest observed in the time series which begins in 1978.

**Environmental Factors:** No abnormal water temperature conditions or long term trends have been noted on Georges Bank.

**Multispecies Considerations:**

**Long-term Prospects:** Sustained stock rebuilding will probably require consistent management by the USA and Canada. Because of the rapid growth rate of this cod stock, if good recruitment occurs and exploitation is reduced, the biomass could increase quickly.

## 2.8. HADDOCK In 4T, 4V and in 4W

**SUMMARY**

Figs. 1.8a - 1.8h

Year - Année	1986	1987	1988	1989	1990	1991	1992	1993	Min. <sup>1</sup>	Med. <sup>1</sup>	Max. <sup>1</sup>
Reference level - Niveau de référence '000t	17	<sup>2</sup>	4.5	6.7	6	<sup>2</sup>	<sup>2</sup>	4.6			
TAC - TPA '000t	17	<sup>3</sup>	<sup>3</sup>	6.9	6	<sup>3</sup>	<sup>3</sup>	<sup>3</sup>			
Rep.catches-Prises décl. '000t	16.9	3.9	4.5	9.1	<sup>4</sup>	5.4 <sup>4</sup>	6 <sup>4</sup>		1.4	11.7	56
Unreported catches Prises non-déclarées											
Est.discards - Rejets est.											
Tot. catches - Prises Tot.											
Ab. #/t (RV/NR) ('000 t)	50.5	30.9	56.2	41.6	42.4	63	28.6		3	38	85
Sp.biomass-Biomasse Rep.											
Mean - F - Moyen											
<sup>1</sup> For/Pour 1954-1992, except/sauf #/t, 1970-1992 <sup>2</sup> 1987 lowest possible, 1991-1992 by-catch only / 1987 plus bas possible, 1991-1992 captures accessoires <sup>3</sup> No TAC, by-catch only / Pas de TPA, captures accessoires seulement <sup>4</sup> Preliminary statistics/Statistiques provisoires											

**Forecast for 1994:** No quantitative catch forecast was calculated.

**Catches:** Landings averaged 26,500t per year from 1950 to 1969. The average was lower from 1970 to 1979 at 5,000t. Landings ranged between 8,000t and 20,000t from 1980 to 1987. Since 1987, landings have been coming exclusively from by-catches in other groundfish fisheries. The 1992 total was about 6,000t.

**Data and Assessment:** The results of both the summer and spring surveys indicate that haddock abundance is decreasing. The bulk of the stock is concentrated in Division 4W and is mainly comprised of the 1988 year-class.

**Fishing Mortality:** Total mortality is believed to have been high in recent years. If natural mortality is  $M=0.20$ , this would mean that fishing mortality is substantially above the  $F_{0.1}=0.25$  target probably in the order of 1.0.

**Recruitment:** There are no indications of strong year-classes after that of 1988.

**State of the Stock:** The stock has essentially disappeared from 4Vn and 4Vs. In 4W, summer survey estimates in 1992 are lower than those for 1991.

**Environmental Factors:** Bottom water temperatures in large portions of the traditional stock area (4V) have been too cold for haddock in recent years. These may have either caused mortality or migration. By restricting the distribution of haddock and therefore concentrating the stock, water temperature may increase the efficiency of fishing where haddock concentrations are located.

**Multispecies Considerations:** Although it is not presently possible to quantify the effects of grey seals on haddock, they do not appear to be an important item in the diet of grey seals.

**Long-term Prospects:** Current stock sizes are much lower than those that produced average catches greater than 25,000t for the period 1950 to 1969. It is not possible to say if and when the stock can rebuild to such levels. However it is certain that current high exploitation rates will not allow such rebuilding. Reducing exploitation on the 1988 year-class will allow for a more rapid rebuilding of spawning stock biomass and increased potential for stronger recruitment.

## 2.9. HADDOCK in 4X

SUMMARY

Figs. 1.9a - 1.9h

Year - Année	1986	1987	1988	1989	1990	1991	1992	1993	Min. <sup>1</sup>	Med. <sup>1</sup>	Max. <sup>1</sup>
Reference level - Niveau de référence '000t	12	12.3	8.2	<4.6	4.6	<sup>2</sup>	<sup>2</sup>	3			
TAC - TPA '000t	15	15	12.4	4.6	4.6	<sup>2</sup>	<sup>2</sup>	6			
Rep.catches-Prises décl. '000t	15	13.6	11	6.7	7.3 <sup>3</sup>	9.7 <sup>3</sup>	10.4 <sup>3</sup>		6.7	18.5	35.9
Unreported catches Prises non-déclarées											
Est.discards - Rejets est.											
Tot. catches - Prises Tot.											
Tot.biomass-Biomasse Tot.											
Sp.biomass-Biomasse Rep. (Female) '000t (RV/NR)	17	12	9	10	15	16			9	17	31
Mean - F - Moyen											
<sup>1</sup> Catches/Prises: 1948-1992; Biomass/Biomasse: 1970-1992. <sup>2</sup> By-catch / Captures accessoires <sup>3</sup> Preliminary statistics/Statistiques provisoires											

**Forecast for 1994:** Catches equal to the 1993 TAC of 6,000t will likely result in a reduction in fishing mortality. Catches of about 6,000t in 1994 would permit a greater contribution to spawning by the 1987-1988 year-classes.

**Catches:** Long term reported landings since 1930 have averaged about 20,000t, and exceeded 30,000t during the 1960s and early 1980s. Landings have been lower than average since 1984, but they have increased recently reaching 10,000t under a "by-catch" fishery.

**Data and Assessment:** Commercial catch rates for both longliners and druggers have increased somewhat in recent years. Survey indices of abundance have generally increased from 1989 to 1991, but the 1992 value is lower than 1991.

**Fishing Mortality:** Fishing mortalities for fish at length for 40, 50, and 60 cm were estimated to have been high (0.5-1.0) throughout the 1980s but have decreased to 1992 (0.25 to 0.50).

**Recruitment:** Has been average or smaller since 1983. The survey results suggest that the 1991 year-class may also be below average.

**State of the Stock:** Stock abundance is higher than the low values of the mid-1980s, but it remains below the productive levels of the 1960s and early 1980s.

**Environmental Factors:**

**Multispecies Considerations:**

**Long-term Prospects:** The 1987 and 1988 year-classes were close to average, but all year-classes since are lower than average. Stock rebuilding is unlikely in the absence of large year-classes.



## 2.10. HADDOCK in 5Z] and in 5Zm

## SUMMARY

Figs. 1.10a - 1.10e

Year - Année	1986	1987	1988	1989	1990	1991	1992	1993	Min. <sup>1</sup>	Med. <sup>1</sup>	Max. <sup>1</sup>
Reference level - Niveau de référence '000t	4.3 <sup>5</sup>	8.3 <sup>5</sup>	8.3 <sup>5</sup>	8.1 <sup>5</sup>	3 <sup>6</sup>	5.4	5	3.5-4			
TAC - TPA '000t	5.1 <sup>4</sup>	8.3 <sup>4</sup>	8.3 <sup>4</sup>	8.3 <sup>4</sup>	NA/ND	5 <sup>2</sup>	5 <sup>2</sup>	5 <sup>2</sup>			
Rep.catches-Prises décl. '000t	5.6	6.1	5.7	3.8	4.5 <sup>3</sup>	6.4 <sup>3</sup>	5.7 <sup>3</sup>		2.4	5.9	25.0
Unreported catches Prises non-déclarées											
Est.discards - Rejets est.											
Tot. catches - Prises Tot.											
Tot.biomass-Biomasse Tot. (000t)	21.5	19.7	18.8	16.5	17.0	15.3	11.8	13.9	7.5	19.7	57.7
Sp.biomass-Biomasse Rep. ('000t)	16.5	13.1	14.4	9.9	15.6	12.6	8.5	4.3	2.2	12.6	42.6
Mean - F - Moyen (4+)	0.33	0.43	0.46	0.32	0.47	0.6	1.29		0.18	0.38	1.29
<sup>1</sup> For/Pour 1969-1992 <sup>2</sup> Canadian quota for the current management unit/Contingent canadien pour l'unité de gestion actuelle <sup>3</sup> Preliminary statistics/Statistiques provisoires <sup>4</sup> Canadian allocations for the management unit used prior to 1990/Allocations canadiennes pour l'unité de gestion avant 1990 <sup>5</sup> For/Pour 5Z <sup>6</sup> Canada only/Canada seulement											

**Forecast for 1994:** The current Canadian allocation of 5,000t for 1993 will result in fishing mortalities greatly exceeding twice the  $F_{0.1} = 0.25$  value.  $F_{0.1}$  catches in 1994 would be about 2,000t, but would be comprised almost entirely (70%) of the incoming 1992 year-class. It is too early to reliably estimate the strength of the 1992 year-class.

**Catches:** The 1992 landings by Canada declined to 4,000t with a substantial shortfall in the mobile gear allocation which is an indication of low abundance. Although catches during January and February 1993 (when haddock are in spawning aggregations) were good, catches in June 1993 following the spawning closure period were generally poor.

**Data and Assessment:** An assessment of yield per recruit for this transboundary resource concluded that the types of benefits expected from fishing at  $F_{0.1}$  (higher catch rates, higher biomasses, and larger fish sizes) could accrue to Canada from unilateral Canadian conservation actions. Yield for Canada and the Canadian  $F_{0.1}$  exploitation rate are not affected much by USA actions because the stock is largely distributed in Canadian waters and migration is limited.

The assessment of the status of the stock was done using sequential population analysis calibrated with ADAPT using the results from the Canadian spring survey and the USA spring and fall surveys.

**Fishing Mortality:** Has been higher than twice  $F_{0.1}$  in recent years and increased markedly in 1992 to the highest level, corresponding to a harvest rate of roughly 60% to 70%.

**Recruitment:** Recent recruitment has been poor, with occasional moderate-sized year-classes being produced. Early indications for the 1992 year-class suggest a moderate strength comparable to those of 1983, 1985, and 1987.

**State of the Stock:** The stock is near the historically low levels which occurred in the mid-1970s. It is a small fraction of the previous average stock sizes from 1920 to the 1960s.

**Environmental Factors:**

**Multispecies Considerations:**

**Long-term Prospects:** Rebuilding of this stock to its long term average will not be possible unless the exploitation rate is decreased substantially. In the absence of a substantial standing stock, catches will fluctuate due to their dependence on variable recruitment. Heavy harvesting of incoming year-classes as soon as they recruit to the fishery will not permit realization of their full growth potential resulting in lost yield. The stock is mostly distributed in Canadian waters with limited migration. Therefore, unilateral Canadian conservation efforts could be effective in managing a healthy stock. However, because the stock is presently severely depleted, consistent restrictive measures by both Canada and USA would enhance the chances of accelerating recovery and restoring the stock biomass.

## 2.11. POLLOCK in 4V, 4W, 4X and in 5Zc

**SUMMARY**

Fig. 1.11a - 1.11h

Year - Année	1986	1987	1988	1989	1990	1991	1992	1993	Min. <sup>1</sup>	Med. <sup>1</sup>	Max. <sup>1</sup>
Reference level - Niveau de référence '000t	43	30	42	42.5	38	43	43	35			
TAC - TPA '000t	40 <sup>2</sup>	43 <sup>2</sup>	43 <sup>2</sup>	43 <sup>2</sup>	43	43	43	35			
Rep.catches-Prises décl. '000t	44	46	43	43	37 <sup>3</sup>	39 <sup>3</sup>	34 <sup>3</sup>		26	37	46
Unreported catches Prises non-déclarées											
Est.discards - Rejets est.											
Tot. catches - Prises Tot.											
Tot.biomass-Biomasse Tot. '000t	179	167	174	155	143	148	148		98	148	208
Sp.biomass-Biomasse Rep. '000t	154	136	124	120	102	96	99		58	104	160
Mean - F - Moyen (7-9)	.57	.69	.61	.56	.61	.71	.55		0.25	0.60	0.87
<sup>1</sup> For/Pour <sup>2</sup> Before 1990 Canadian allocation / Avant 1990, allocation canadienne <sup>3</sup> Preliminary statistics/Statistiques provisoires											

**Forecast for 1994:** Fishing at  $F_{0.1}$  would imply catches of about 20,000t in 1994.

**Catches:** Decreased from 39,000t in 1991 to 34,000t in 1992, continuing a generally decreasing trend since 1987. The decrease in catches is more pronounced in 4VW than in 4X+5Zc and catches have become more concentrated during May-August.

**Data and Assessment:** The assessment is made using Sequential Population Analysis calibrated with the summer research vessel survey results. Survey population estimates have decreased substantially from the high value observed in 1990. The survey shows strong year to year variability, making it difficult to estimate abundance.

**Fishing Mortality:** Fishing mortality has been about  $F=0.60$  on fully recruited ages, twice the  $F_{0.1}=0.30$  target.

**Recruitment:** Recruitment has averaged 28 million since 1974. The 1989 year-class appears to be above average.

**State of the Stock:** Pollock abundance is currently lower than average and it is expected to continue to decrease.

**Environmental Factors:**

**Multispecies Considerations:**

**Long-term Prospects:** The average productivity of pollock in this area since 1974 has been 37,000t, with catches in the 1980s being generally higher than average as a result of the strong 1979 year-class. If fishing mortality remains high, the 1989 year-class, which may be above average, will not contribute substantially to spawning stock increases.

## 2.12. REDFISH in 4R,4S,4T,3Pn(J.-M.) and in 4Vn(J.-M.)

**SUMMARY**

Figs. 1.12a - 1.12d

Year - Année	1986	1987	1988	1989	1990	1991	1992	1993	Min. <sup>1</sup>	Med. <sup>1</sup>	Max. <sup>1</sup>
Reference level - Niveau de référence '000t							67	60			
TAC - TPA '000t						New Management Unit / Nouvelle Unité de Gestion		67	60		
Rep.catches-Prises décl. '000t	36	43.5	52	52.5	60 <sup>2</sup>	59.5 <sup>2</sup>	77 <sup>2</sup>		7.1	44	136
Unreported catches Prises non-déclarées											
Est.discards - Rejets est.											
Tot. catches - Prises Tot.											
Tot.biomass-Biomasse Tot.											
Sp.biomass-Biomasse Rep.											
Mean - F - Moyen											
<sup>1</sup> For/Pour 1959-1992 <sup>2</sup> Preliminary statistics/Statistiques provisoires											

**Forecast for 1994:** No quantitative forecast was made. Recent catches are expected to result in rapid decline in abundance.

**Catches:** Catches have increased substantially in 1992, exceeding the TAC suggested for the new management unit by 10,000t.

**Data and Assessment:** Commercial catch per unit of effort and research vessel surveys are used as indices of abundance. The commercial CPUE increased about 20% from 1991 to 1992. The research surveys suggest either stability or a decline in abundance.

**Fishing Mortality:** No quantitative estimate available.

**Recruitment:** The 1988 year-class still appears strong, but it may be weaker than previously estimated. It will start to contribute to the fishery in 3-4 years.

**State of the Stock:** The stock is still quite abundant but it is expected to continue to decrease as a result of fishing and natural mortality until the 1988 year-class reaches maturity and is recruited to the fishery.

**Environmental Factors:**

**Multispecies Considerations:**

**Long-term Prospects:** Redfish stocks are noted for recruitment occurring only periodically. This leads to wide fluctuations in stock abundance. Given that the incidence of strong year-classes is infrequent and that growth rates are very low, fishing mortalities on redfish stocks must be maintained at low levels.

## 2.13. AMERICAN PLAICE in Subarea 2 and in 3K

**SUMMARY**

Figs. 1.13a - 1.13d

Year - Année	1986	1987	1988	1989	1990	1991	1992	1993	Min. <sup>1</sup>	Med. <sup>1</sup>	Max. <sup>1</sup>
Reference level - Niveau de référence '000t	10	10	10	10	10	10	10	5			
TAC - TPA '000t	10	10	10	10	10	10	10	5			
Rep.catches-Prises décl. '000t	3	1.1	1	4.2	1.8 <sup>2</sup>	.5 <sup>2</sup>	.1 <sup>2</sup>		.1	3.6	12.7
Unreported catches Prises non-déclarées											
Est.discards - Rejets est.											
Tot. catches - Prises Tot.											
Tot.biomass-Biomasse Tot.											
Sp.biomass-Biomasse Rep.											
Mean - F - Moyen											
<sup>1</sup> For/Pour 1963-1992 <sup>2</sup> Preliminary statistics/Statistiques provisoires											

**Forecast for 1994:** No quantitative forecast is possible. However stock size is very low.

**Catches:** Catches in the last two years are the lowest in the time series. The low 1992 catches may be due, in part, to low fishing activity as a result of the cod moratorium.

**Data and Assessment:** Research vessel survey results are used as indices of abundance. They show a steep decline in biomass from the late 1980s to the present, despite low commercial catches.

**Fishing Mortality:** Total mortality is likely very high in order to have caused such a rapid decrease in abundance. However, reported catches cannot explain such a rapid decrease. Misreporting of catches and migration are thought to be unlikely causes.

**Recruitment:** Research surveys indicate a decline in recent years.

**State of the Stock:** This stock had declined to very low abundance by the end of 1992. The current TAC of 5,000t is about equal to the total biomass estimate from the 1992 survey. This means that if the TAC were to be caught, it would result in very high fishing mortalities on a stock which is at an extremely low level.

**Environmental Factors:** Extreme oceanographic conditions may have increased natural mortality by an unknown mechanism.

**Multispecies Considerations:**

**Long-term Prospects:** The prospects for rebuilding in the long term are unknown. There is no sign of good recruitment. Considering that plaice ages 9-12 comprise the majority of commercial catches, a recovery of the fishery is unlikely before at least 10 years. Both the total and the spawning stock biomasses are far below any previous estimate in the 15-year time series.

## 2.14. AMERICAN PLAICE in 3Ps

**SUMMARY**

Figs. 1.14a - 1.14f

Year - Année	1986	1987	1988	1989	1990	1991	1992	1993	Min. <sup>1</sup>	Med. <sup>1</sup>	Max. <sup>1</sup>
Reference level - Niveau de référence '000t	5	5	5	5	4	4	3	3			
TAC - TPA '000t	5	5	5	5	4	4	4	3			
Rep.catches-Prises décl. '000t	5.1	5.3	4.4	4	4.8 <sup>2</sup>	4.4 <sup>2</sup>	2.3 <sup>2</sup>		.8	4.2	14.8
Unreported catches Prises non-déclarées											
Est.discards - Rejets est.											
Tot. catches - Prises Tot.											
Tot.biomass-Biomasse Tot.											
Sp.biomass-Biomasse Rep.											
Mean - F - Moyen											
<sup>1</sup> For/Pour 1960-1992. <sup>2</sup> Preliminary statistics/Statistiques provisoires											

**Forecast for 1994:** In the short term, fisheries can expect a continued down-turn, with no immediate prospects for stock rebuilding.

**Catches:** The Canadian inshore catch in 1992 declined to the lowest value since 1985. The catch by Canadian offshore trawlers in 1992 was the lowest since 1983, at about half the 1990 and 1991 values. The total 1992 catch was 2,300t, a 50% decrease compared with the average of the last 6 years.

**Data and Assessment:** The commercial catch per unit of effort decreased sharply in 1991 and 1992 to the lowest levels observed. Research surveys biomass estimates were relatively stable around 30,000t in 1986-1988, the 1989 estimate was 17,000t and 4 of the 5 surveys since have estimated the biomass at less than 7,000t. The two surveys conducted in 1993 gave biomasses less than 5,000t.

**Fishing Mortality:** Total mortality is likely very high in order to have caused such a rapid decrease in abundance. Although recent catches have likely exceeded  $F_{0.1}$ , it is unlikely that reported catches are solely responsible for the observed decline in abundance. Misreporting of catches and migration are thought to be unlikely causes.

**Recruitment:** Recruitment is very low according to the surveys.

**State of the Stock:** Similar to other American plaice stocks in the Newfoundland and Labrador area, 3Ps plaice has declined markedly since the mid-to-late 1980s and is now below any previously observed value. The TAC of 3000t is in the range of the total biomass estimate from the 1993 survey. If caught, the TAC would result in a very high fishing mortality on a stock that is at an extremely low level.

**Environmental Factors:** Oceanographic conditions in 1985 may have concentrated plaice, resulting in higher catchabilities to the commercial fishery and to the surveys.

**Multispecies Considerations:**

**Long-term Prospects:** The prospects for rebuilding in the long term are unknown. Both the total and the spawning stock biomasses are far below any previous estimate in the 15 years time series. There is no sign of good recruitment.

**2.15. AMERICAN PLAICE in 4T**  
**SUMMARY**  
 Figs. 1.15a - 1.15b

Year - Année	1986	1987	1988	1989	1990	1991	1992	1993	Min. <sup>1</sup>	Med. <sup>1</sup>	Max. <sup>1</sup>
Reference level/Niveau de référence '000t	10	10	10	8	10	10	10	10			
TAC - TPA '000t	10	10	10	10	10	10	10	5			
Rep.catches-Prises décl. '000t	7.2	8	7	5.7	5.6 <sup>2</sup>	5.2 <sup>2</sup>	5.1 <sup>2</sup>		5.1	8.5	11.8
Unreported catches Prises non-déclarées											
Est.discards - Rejets est.						3.2	3.3				
Tot. catches - Prises Tot.						8.2	8.3				
Tot.biomass-Biomasse Tot. (RV/NR) '000t	94	76	87	63	81	106	65		63	150	338
Sp.biomass-Biomasse Rep.											
Mean - F - Moyen											
<sup>1</sup> Catches/Prises: 1965-1992; Biom: 1970-1992. <sup>2</sup> Preliminary statistics/Statistiques provisoires											

**Forecast for 1994:** Quantitative forecast is not possible, but landings are expected to remain stable or decrease.

**Catches:** Past total catches are not known because of substantial discarding. Landings have consistently been lower than the TAC except in 1979. Landings have decreased steadily since the mid-1980s.

**Data and Assessment:** The results of a September groundfish survey are used as an index of abundance. They have also been used to estimate total mortality trends, biomass trends and year-class trends.

**Fishing Mortality:** Recent total mortality estimated from the survey is 0.54. Assuming  $M=0.20$ , this implies a fishing mortality of  $F=0.34$ , between  $F_{0.1}$  and twice  $F_{0.1}$ .

**Recruitment:** Recruitment appears to have decreased from 1972 to 1981 but has increased since, although recent estimates are not precise.

**State of the Stock:** The stock is currently much lower than in the mid-1970s. Recruitment appears to have been increasing since 1982.

**Environmental Factors:**

**Multispecies Considerations:** Snow crab, lobster, herring and mackerel have been and probably still are abundant in this area.

**Long-term Prospects:** Yield from this plaice resource could be increased substantially if discarded plaice were not caught and were allowed to grow until they reach an appropriate commercial size.

**2.16. AMERICAN PLAICE in 4V and In 4W**  
**SUMMARY**  
 Figs. 1.16a - 1.16c

Year - Année	1986	1987	1988	1989	1990	1991	1992	1993	Min. <sup>1</sup>	Med. <sup>1</sup>	Max. <sup>1</sup>	
Reference level/Niveau de référence												
TAC - TPA	New Management Unit / Nouvelle Unité de Gestion											
Rep.catches-Prises décl. '000t						.4 <sup>2,3</sup>	.5 <sup>2,3</sup>					
Unreported catches Prises non-déclarées												
Est.discards - Rejets est.												
Tot. catches - Prises Tot.												
Tot.biomass-Biomasse Tot.												
Sp.biomass-Biomasse Rep.												
Mean - F - Moyen												
<sup>1</sup> For/Pour <sup>2</sup> Prior to 1991, species identification is unreliable / Avant 1991, l'identification spécifique n'est pas fiable. <sup>3</sup> Preliminary statistics/Statistiques provisoires												

**Forecast for 1994:** Assuming that the exploitation rate remains stable, catches are expected to also remain stable.

**Catches:** Landings data are not reliable because plaice are reported as unspecified flounder.

**Data and Assessment:** Estimates from summer and spring surveys are used as indices of abundance.

**Fishing Mortality:**

**Recruitment:**

**State of the Stock:** The index of abundance from the summer research surveys has recently been increasing except in 1992. The index from the spring surveys has been declining since 1990.

**Environmental Factors:**

**Multispecies Considerations:**

**Long-term Prospects:**

**2.17. AMERICAN PLAICE in 4X  
SUMMARY**  
Figs. 1.17a - 1.17b

Year - Année	1986	1987	1988	1989	1990	1991	1992	1993	Min. <sup>1</sup>	Med. <sup>1</sup>	Max. <sup>1</sup>	
Reference level/Niveau de référence												
TAC - TPA	New Management Unit / Nouvelle Unité de Gestion											
Rep.catches-Prises décl. '000t						1.0 <sup>2,3</sup>	.4 <sup>2,3</sup>					
Unreported catches Prises non-déclarées												
Est.discards - Rejets est.												
Tot. catches - Prises Tot.												
Tot.biomass-Biomasse Tot.												
Sp.biomass-Biomasse Rep.												
Mean - F - Moyen												
<sup>1</sup> For/Pour <sup>2</sup> Prior to 1991, species identification is unreliable / Avant 1991, l'identification spécifique n'est pas fiable. <sup>3</sup> Preliminary statistics/Statistiques provisoires												

**Forecast for 1994:** Assuming that the exploitation rate remains stable, catches are also expected to remain stable.

**Catches:** Landings data are not reliable because plaice were reported as unspecified flounder.

**Data and Assessment:** Estimates from summer and spring surveys are used as indices of abundance.

**Fishing Mortality:**

**Recruitment:**

**State of the Stock:** Abundance estimates from the summer surveys have increased in the last two years.

**Environmental Factors:**

**Multispecies Considerations:**

**Long-term Prospects:**



## 2.18. Witch 2J, 3K, and in 3L

**SUMMARY**

Figs. 1.18a - 1.18c

Year - Année	1986	1987	1988	1989	1990	1991	1992	1993	Min. <sup>1</sup>	Med. <sup>1</sup>	Max. <sup>1</sup>
Reference level/Niveau de référence '000t	8	4	4	4	4	4	4	4			
TAC - TPA '000t	8	6	5	5	4	4	4	4			
Rep.catches-Prises décl. '000t	3.9	4.5	4.2	4.9	3.6 <sup>2</sup>	4 <sup>2</sup>	2.3 <sup>2</sup>		.9	4	24
Unreported catches Prises non-déclarées											
Est.discards - Rejets est.											
Tot. catches - Prises Tot.											
Tot.biomass-Biomasse Tot.											
Sp.biomass-Biomasse Rep.											
Mean - F - Moyen											
<sup>1</sup> For/Pour 1963-1992 <sup>2</sup> Preliminary statistics/Statistiques provisoires											

**Forecast for 1994:** No quantitative forecast possible.

**Catches:** Catches fluctuated between 3,000t and 4,500t from 1980 to 1991. Catches in 1992 decreased to 2,300t.

**Data and Assessment:** Commercial catch per unit of effort fluctuated widely in the late 1980s, reaching very high values in 1986 and 1989, perhaps reflecting increased concentrations of fish rather than higher stock sizes. Biomass estimates from research surveys have decreased from about 40,000-45,000t in the early 1980s, to about 2,500t in 1992. The geographical distribution of witch in the surveys changed suddenly in 1986 after the 1985 survey. The area of distribution has gradually decreased since. The fishery in recent years has been prosecuted in depths deeper than those covered by the survey.

**Fishing Mortality:**

**Recruitment:** The decrease in biomass from the mid-1980s implies that recruitment has been very small to non-existent during that period.

**State of the Stock:** The stock is presently the lowest recorded. The biomass outside of the survey area is not believed to be very high.

**Environmental Factors:** Harsh oceanographic conditions may have played a role in the decreased abundance of witch.

**Multispecies Considerations:**

**Long-term Prospects:** The prospects for rebuilding in the long term are unknown. Both the total and the spawning stock biomasses are far below any previous estimate in the 15-year time series.

**2.19. WITCH in 3Ps**  
**SUMMARY**  
 Figs. 1.19a - 1.19b

Year - Année	1986	1987	1988	1989	1990	1991	1992	1993	Min. <sup>1</sup>	Med. <sup>1</sup>	Max. <sup>1</sup>
Reference level/Niveau de référence '000t	3	3Max	1	1	1	1	1	1			
TAC - TPA '000t	3	3	1	1	1	1	1	1			
Rep.catches-Prises décl. '000t	1.3	1.3	.6	.9	1.0 <sup>2</sup>	1.1 <sup>2</sup>	1.0 <sup>2</sup>		.4	1.0	4.8
Unreported catches Prises non-déclarées											
Est.discards - Rejets est.											
Tot. catches - Prises Tot.											
Tot.biomass-Biomasse Tot.											
Sp.biomass-Biomasse Rep.											
Mean - F - Moyen											
<sup>1</sup> For/Pour 1960-1992 <sup>2</sup> Preliminary statistics/Statistiques provisoires											

**Forecast for 1994:** A quantitative forecast is not possible.

**Catches:** Catches have generally been about 1,000t since 1979.

**Data and Assessment:** Biomass has been estimated by research surveys since 1976. Biomass estimates were generally between 3,000t and 6,000t during the 1980s, with no identifiable persistent trend. Estimated biomass was about 2,000t in February 1993, but the 1993 April survey estimate increased to about 3,000t.

**Fishing Mortality:**

**Recruitment:**

**State of the Stock:** The state of the stock is uncertain. The 1993 survey estimates are within the range of variability during the last 10-15 years.

**Environmental Factors:**

**Multispecies Considerations:**

**Long-term Prospects:** Long term prospects are uncertain. The 1993 fishery was considered highly successful, however, it occurred on a very densely aggregated pre-spawning concentration and may not be representative of stock abundance.

**2.20. WITCH in 4RS  
SUMMARY**

Figs. 1.20a - 1.20c

Year - Année	1986	1987	1988	1989	1990	1991	1992	1993	Min. <sup>1</sup>	Med. <sup>1</sup>	Max. <sup>1</sup>
Reference level/Niveau de référence '000t	3.5	3.5	3.5	3.5	3.5	3.5	3.5	3.5			
TAC - TPA '000t	3.5	3.5	3.5	3.5	3.5	3.5	3.5	3.5			
Rep.catches-Prises décl. '000t	.7	.9	1.1	1.2	.6 <sup>2</sup>	.5 <sup>2</sup>	.4 <sup>2</sup>		.2	1.5	5.3
Unreported catches Prises non-déclarées											
Est.discards - Rejets est.											
Tot. catches - Prises Tot.											
Tot.biomass-Biomasse Tot.											
Sp.biomass-Biomasse Rep.											
Mean - F - Moyen											
<sup>1</sup> For/Pour 1960 to 1992 <sup>2</sup> Preliminary statistics/Statistiques provisoires											

**Forecast for 1994:** A quantitative forecast is not possible. However, based on the results of research surveys and the commercial fishery, catches are expected to remain low, particularly in 4R.

**Catches:** Catches have decreased steadily for the last three years. They have been lower than 1000t every year since 1983, except in 1988-89.

**Data and Assessment:** Qualitative interpretation of the research survey results and of the commercial fishery.

**Fishing Mortality:**

**Recruitment:**

**State of the Stock:** The abundance of this stock is thought to be low.

**Environmental Factors:**

**Multispecies Considerations:**

**Long-term Prospects:** Catches since 1960 for this stock have averaged 1,800t. Given the current stock size and age of recruitment, stock rebuilding is expected to be slow. The definition of the stock unit will be studied to determine if catches in 4T, close to the stock unit, should be assigned to 4RS witch.

**2.21. WITCH in 4V and in 4W**  
**SUMMARY**  
 Figs. 1.21a - 1.21c

Year - Année	1986	1987	1988	1989	1990	1991	1992	1993	Min. <sup>1</sup>	Med. <sup>1</sup>	Max. <sup>1</sup>
Reference level/Niveau de référence											
TAC - TPA	New Management Unit / Nouvelle Unité de Gestion										
Rep.catches-Prises décl. '000t						1.3 <sup>2,3</sup>	1.0 <sup>2,3</sup>				
Unreported catches Prises non-déclarées											
Est.discards - Rejets est.											
Tot. catches - Prises Tot.											
Tot.biomass-Biomasse Tot.											
Sp.biomass-Biomasse Rep.											
Mean - F - Moyen											
<sup>1</sup> For/Pour <sup>2</sup> Prior to 1991, species identification is unreliable / Avant 1991, l'identification spécifique n'est pas fiable. <sup>2</sup> Preliminary statistics/Statistiques provisoires											

**Forecast for 1994:** Catches are expected to decrease as a result of declining abundance.

**Catches:** Landings have been decreasing. The species identification is more reliable because witch command a higher price.

**Data and Assessment:** Estimates from a summer and a spring survey are used as indices of abundance.

**Fishing Mortality:**

**Recruitment:**

**State of the Stock:** Summer survey abundance estimates indicate stable biomasses at low values. The spring survey estimates declined from 1987 to 1990 but have remained stable since.

**Environmental Factors:**

**Multispecies Considerations:**

**Long-term Prospects:**

**2.22. WITCH in 4X  
SUMMARY  
Figs. 1.22a - 1.22b**

Year - Année	1986	1987	1988	1989	1990	1991	1992	1993	Min. <sup>1</sup>	Med. <sup>1</sup>	Max. <sup>1</sup>
Reference level/Niveau de référence											
TAC - TPA	New Management Unit / Nouvelle Unité de Gestion										
Rep.catches-Prises décl. '000t											
Unreported catches Prises non-déclarées											
Est.discards - Rejets est.											
Tot. catches - Prises Tot.											
Tot.biomass-Biomasse Tot.											
Sp.biomass-Biomasse Rep.											
Mean - F - Moyen											
<sup>1</sup> For/Pour <sup>2</sup> Prior to 1991, species identification is unreliable / Avant 1991, l'identification spécifique n'est pas fiable. <sup>3</sup> Preliminary statistics/Statistiques provisoires											

**Forecast for 1994:** Catches are expected to decrease as a result of declining abundance.

**Catches:** Landings have been decreasing. The species identification is more reliable because witch command a higher price.

**Data and Assessment:** Estimates from a summer survey are used as indices of abundance.

**Fishing Mortality:**

**Recruitment:**

**State of the Stock:** Increasing catches may be due to increased fishing effort as a result of the introduction of individual quotas. Estimates of abundance from the surveys have been decreasing since 1984.

**Environmental Factors:**

**Multispecies Considerations:**

**Long-term Prospects:**

**2.23. YELLOWTAIL in 4V and 4W**  
**SUMMARY**  
 Figs. 1.23a - 1.23b

Year - Année	1986	1987	1988	1989	1990	1991	1992	1993	Min. <sup>1</sup>	Med. <sup>1</sup>	Max. <sup>1</sup>
Reference level/Niveau de référence											
TAC - TPA	New Management Unit / Nouvelle Unité de Gestion										
Rep.catches-Prises décl. '000t						1.3 <sup>2,3</sup>	1.4 <sup>2,3</sup>				
Unreported catches Prises non-déclarées											
Est.discards - Rejets est.											
Tot. catches - Prises Tot.											
Tot.biomass-Biomasse Tot.											
Sp.biomass-Biomasse Rep.											
Mean - F - Moyen											
<sup>1</sup> For/Pour <sup>2</sup> Prior to 1991, species identification is unreliable / Avant 1991, l'identification spécifique n'est pas fiable. <sup>3</sup> Preliminary statistics/Statistiques provisoires											

**Forecast for 1994:** Landings are expected to remain stable or increase slightly.

**Catches:** Landings data are not reliable because of problems with species identification and reporting.

**Data and Assessment:** Estimates from a summer and a spring survey are used as indices of abundance.

**Fishing Mortality:**

**Recruitment:**

**State of the Stock:** Estimates of abundance from the summer surveys have generally been stable with perhaps an increase recently. The estimates from the spring surveys have generally decreased since 1988.

**Environmental Factors:**

**Multispecies Considerations:**

**Long-term Prospects:**

**2.24. YELLOWTAIL in 4X  
SUMMARY  
Fig. 1.24a**

Year - Année	1986	1987	1988	1989	1990	1991	1992	1993	Min. <sup>1</sup>	Med. <sup>1</sup>	Max. <sup>1</sup>						
Reference level/Niveau de référence	<div style="border: 1px solid black; padding: 5px; display: inline-block;">           New Management Unit / Nouvelle Unité de Gestion         </div>																
TAC - TPA																	
Rep.catches-Prises décl. '000t														.15 <sup>2,3</sup>	.12 <sup>2,3</sup>		
Unreported catches Prises non-déclarées																	
Est.discards - Rejets est.																	
Tot. catches - Prises Tot.																	
Tot.biomass-Biomasse Tot.																	
Sp.biomass-Biomasse Rep.																	
Mean - F - Moyen																	
<sup>1</sup> For/Pour <sup>2</sup> Prior to 1991, species identification is unreliable / Avant 1991, l'identification spécifique n'est pas fiable. <sup>3</sup> Preliminary statistics/Statistiques provisoires																	

**Forecast for 1994:** Catches are expected to remain stable at a low level.

**Catches:** Landings data are not reliable because of problems with species identification and reporting.

**Data and Assessment:** Estimates from summer surveys are used as indices of abundance.

**Fishing Mortality:**

**Recruitment:**

**State of the Stock:** Based on the surveys, the stock appears stable at a low level, and perhaps slightly increasing.

**Environmental Factors:**

**Multispecies Considerations:**

**Long-term Prospects:**

## 2.25. ATLANTIC HALIBUT in 3N, 3O, 3Ps, 4V, 4W, and in 4X

SUMMARY

Figs. 1.25a - 1.25d

Year - Année	1986	1987	1988	1989	1990	1991	1992	1993	Min. <sup>1</sup>	Med. <sup>1</sup>	Max. <sup>1</sup>
Reference level/Niveau de référence '000t	-	-	3.2	3.2	3.2	3.2	3.2	3.2			
TAC - TPA '000t	-	-	3.2	3.2	3.2	3.2	3.2	3.2			
Rep.catches-Prises décl. '000t	3.3	2.6	2.3	1.9	2. <sup>2</sup>	2.2 <sup>2</sup>	1.3 <sup>2</sup>		1.1	1.9	4.0
Unreported catches Prises non-déclarées											
Est.discards - Rejets est.											
Tot. catches - Prises Tot.											
Tot.biomass-Biomasse Tot.											
Sp.biomass-Biomasse Rep.											
Mean - F - Moyen											
<sup>1</sup> For/Pour 1961-1992. <sup>2</sup> Preliminary statistics/Statistiques provisoires											

**Forecast for 1994:** The Atlantic halibut stock size appears to be decreasing and catches are expected to continue to decline.

**Catches:** Catches have decreased more or less steadily from a maximum of 4,000t in 1985 to 1,331 in 1992.

**Data and Assessment:** Landings, commercial catch rates and biomass estimates from research surveys were used as indices of abundance. The landings suggest a decreasing stock size while the commercial catch rates have decreased markedly since 1988 despite technological improvements to fishing. The biomass estimates from research surveys have increased from 1983 to 1989, but they have fluctuated since, perhaps with a downward trend.

**Fishing Mortality:**

**Recruitment:**

**State of the Stock:** The stock is decreasing based on declining commercial catch rates and landings. The stock is now less abundant than when the 3,200t TAC was established.

**Environmental Factors:**

**Multispecies Considerations:**

**Long-term Prospects:**



**2.26. ATLANTIC HALIBUT in 4R, 4S and in 4T**  
**SUMMARY**  
 Fig. 1.26a

Year - Année	1986	1987	1988	1989	1990	1991	1992	1993	Min. <sup>1</sup>	Med. <sup>1</sup>	Max. <sup>1</sup>
Reference level/Niveau de référence '000t	-	-	.3	.3	.3	.3	.3	.3			
TAC - TPA '000t	-	-	.3	.3	.3	.3	.3	.3			
Rep.catches-Prises décl. '000t		.3	.2	.3	.4 <sup>2</sup>	.3 <sup>2</sup>	.2 <sup>2</sup>		.091	.189	.411
Unreported catches Prises non-déclarées											
Est.discards - Rejets est.											
Tot. catches - Prises Tot.											
Tot.biomass-Biomasse Tot.											
Sp.biomass-Biomasse Rep.											
Mean - F - Moyen											
<sup>1</sup> For/Pour 1979-1992 <sup>2</sup> Preliminary statistics/Statistiques provisoires											

**Forecast for 1994:** It is not possible to make a quantitative forecast.

**Catches:** Catches have exceeded the TAC in 1990 and 1991. The 1992 catches are substantially lower.

**Data and Assessment:** Biological update based on examination of landings data and limited information on catch composition.

**Fishing Mortality:**

**Recruitment:**

**State of the Stock:** Landings increased from 1979 to 1990 although there was considerable interannual variability but they have abruptly decreased since. This may indicate lower stock abundance or may be the result of lower fishing effort or lower availability of the halibut.

**Environmental Factors:**

**Multispecies Considerations:**

**Long-term Prospects:**

## 2.27. GREENLAND HALIBUT in 4R, 4S and in 4T

SUMMARY

Figs. 1.27a - 1.27c

Year - Année	1986	1987	1988	1989	1990	1991	1992	1993	Min. <sup>1</sup>	Med. <sup>1</sup>	Max. <sup>1</sup>
Reference level/Niveau de référence '000t	5	-	-	-	-	-	-	4			
TAC - TPA '000t	5	8.9	10.5	10.5	10.5	10.5	10.5	4			
Rep.catches-Prises décl. '000t	6.5	11	8	5	2.4 <sup>2</sup>	2.3 <sup>2</sup>	3.4 <sup>2</sup>		.7	2.3	11
Unreported catches Prises non-déclarée											
Est.discards - Rejets est.											
Tot. catches - Prises Tot.											
Tot.biomass-Biomasse Tot.											
Sp.biomass-Biomasse Rep.											
Mean - F - Moyen											
<sup>1</sup> For/Pour 1970-1992 <sup>2</sup> Preliminary statistics/Statistiques provisoires											

**Forecast for 1994:** Catches are expected to increase as a result of increased fishing effort and perhaps increased abundance.

**Catches:** Catches have fluctuated as a result of fluctuations in recruitment. Catches increased in 1992 for the first time since 1987.

**Data and Assessment:** Estimates from a summer research survey suggest that the biomass increased sharply from 1990 to 1991 but only slightly in 1992.

**Fishing Mortality:** The fishing mortality is not known precisely, but it is likely quite high.

**Recruitment:** It is too early to estimate recruiting year-classes with precision, but there are some positive signs from the surveys and the shrimpers that recruitment may be increasing.

**State of the Stock:** The stock was quite low but may be increasing.

**Environmental Factors:**

**Multispecies Considerations:**

**Long-term Prospects:** Not known. Will depend on future recruitment. However sustained rebuilding is unlikely unless exploitation rates are decreased substantially.

**2.28. COD in 4Vn during May to December**  
**SUMMARY**

Year - Année	1986	1987	1988	1989	1990	1991	1992	1993	Min. 1	Med. <sup>1</sup>	Max. 1
Reference level - Niveau de référence '000t	10	6.1	7.5	7.5	7.5	7.5-10	decrease	1.8			
TAC - TPA '000t	12	9	7.5	7.5	7.5	10	10	1.8			
Rep.catches-Prises décl. '000t	12	10.5	9	7.6	5.2 <sup>2</sup>	4.6 <sup>2</sup>	4.3 <sup>2</sup>				
Unreported catches Prises non-déclarées											
Est.discards - Rejets est.											
Tot. catches - Prises Tot.											
Tot.biomass-Biomasse Tot.											
Sp.biomass-Biomasse Rep.											
Mean - F - Moyen											
<sup>1</sup> For/Pour <sup>2</sup> Preliminary statistiques/Statistiques provisoires											

**Forecast for 1994:** No quantitative forecast possible.

**Catches:** Catches have decreased rapidly in the last five years, particularly in the fixed gear sector which has been unable to catch its allocation in the past three years.

**Data and Assessment:** Stock mixing with neighboring stocks in this area precludes an analytical assessment. Research vessel survey biomass estimates are available since 1970. They are highly variable because of stock mixing and small sample size. Information on fishing effort is available only for a small portion of the fleets and is not considered a reliable index of stock size.

**Fishing Mortality:** Fishing mortality is not estimated precisely, but is likely above  $F_{0.1}$ .

**Recruitment:** The 1986 and 1987 year-classes are the only ones above average in the stock. More recent year-classes do not appear strong.

**State of the Stock:** The longliner catches are very poor, and a major portion of the landings are coming from migrating 4T fish. The stock abundance is very low.

**Environmental Factors:** Declining abundance may have been exacerbated by cooling trends experienced throughout this general area.

**Multispecies Considerations:**

**Long-term Prospects:** Rebuilding will be slow and may require a substantial reduction in exploitation rate.

## 2.29. REDFISH IN 2+3K SUMMARY

Year - Année	1986	1987	1988	1989	1990	1991	1992	1993	Min.	Med.	Max
Reference level - Niveau de référence	35	35	35	35	35	20	20	20			
TAC - TPA '000t	35	35	35	35	35	20	20 <sup>4</sup>	20 <sup>4</sup>	20 <sup>1</sup>	32 <sup>1</sup>	35 <sup>1</sup>
Rep.catches - Prises décl. '000t	27	19	7	3	2.4 <sup>3</sup>	0.4 <sup>3</sup>	0 <sup>3</sup>		0 <sup>2</sup>	25 <sup>2</sup>	130 <sup>2</sup>
Unreported catches Prises non-déclarées											
Est.discards - Rejets est.											
Tot.catches - Prises Tot.											
Tot.biomass-Biomasse Tot.											
Sp.biomass-Biomasse Rep.											
Mean - F - Moyen											
<sup>1</sup> For 1974-1993/Pour 1974-1993 <sup>2</sup> For 1960-1992/Pour 1960-1992 <sup>3</sup> Preliminary statistics/Statistiques provisoires <sup>4</sup> 1991-1993 TAC - multi-year management plan/1991-1993 TPA - le plan pluri-annuel											

**Forecast for 1994:** Although there is no information to precisely estimate fishing mortality or exploitation rate generated by recent catches, it is considered that catches in the order of the present TAC (20,000 t) would be very detrimental to the population if achieved.

**Catches:** Catches since 1960 ranged from 9t to 130,000t. Between 1961 and 1977, catches averaged about 28,000t. In the early 1980s, landings ranged from 14,000t to 18,000t and increased to between 24,000t to 29,000t from 1984 to 1986 in response to improved markets. Since 1986, landings have drastically declined annually to the record low of about 9t in 1992. These reductions have come about because of persistent complaints of external parasite infestation and a diversion of effort by the principal Canadian harvester to other fisheries because of low catch rates.

**Data and Assessment:** The information is not adequate for an analytical assessment. Standardized commercial CPUE shows high variability between some years but indicates a general decrease from 1984 to 1990. Limited fishing effort has occurred since 1990. Research vessel trawl surveys to 2J and 3K indicate declines in biomass in both divisions since the early 1980s. Trawlable biomass estimates since 1989 are consistently low in 2J and 3K and indicate that the population is at a very low level compared to estimates from the early 1980s.

**Fishing mortality:**

**Recruitment:** There has been no substantial recruitment since the year-classes of the early 1970s.

**State of the Stock:** The stock is at a low level due to poor recruitment. The 1992 survey of Div. 2J3K indicates trawlable biomass to be at an historically low level.

**Environmental Factors:**

**Multi-species considerations:**

**Long-term Prospects:** The stock will continue to decline until good recruitment takes place, and prospects for the fishery will not improve until 8-10 years after good recruitment occurs.

### 2.30. Redfish in 30 SUMMARY

Year - Année	1986	1987	1988	1989	1990	1991	1992	1993	Min.	Med.	Max.
Reference level - Niveau de référence '000t	20	20	14	14	14	14	14	14			
TAC - TPA '000t	20	20	14	14	14	14 <sup>4</sup>	14 <sup>4</sup>	14 <sup>4</sup>	14 <sup>1</sup>	18 <sup>1</sup>	21.9 <sup>1</sup>
Rep. catches-Prises décl. '000t	10	13	11	11	9 <sup>3</sup>	7.5 <sup>3</sup>	9.5 <sup>3</sup>		5 <sup>2</sup>	13.3 <sup>2</sup>	25 <sup>2</sup>
Unreported catches Prises non-déclarées est. '000t		11	13.5	-	1.9	0.4	1.5				
Est. discards - Rejets est.											
Tot. catches - Prises Tot.											
Tot.biomass-Biomasse Tot.											
Sp.biomass-Biomasse Rep.											
Mean F - Moyen											
<sup>1</sup> For 1974-1993/Pour 1974-1993 <sup>2</sup> For 1959-1992/Pour 1959-1992 <sup>3</sup> Preliminary statistics/Statistiques provisoires <sup>4</sup> 1991-1993 TAC - multi-year management plan/1991-1993 TPA - le plan pluri-annuel											

**Forecast for 1994:** There is no information upon which to base a forecast of this stock.

**Catches:** Catches since 1959 have ranged between 5,000t and 25,000t. From 1980 to 1986, an average about 11,000t was taken. In 1987, catches increased to 24,000t and remained at that level in 1988. In 1989 catches declined to 11,000t and have been at this level ever since. The increase in 1987 and 1988 was due to the activity of fleets that are not members of NAFO (primarily those of Panama). Russia and Cuba account for most of the catch. Canada has taken less than 300 t per year since 1983.

**Data and Assessment:** The information is not adequate for an analytical assessment. Estimates of relative abundance from research vessel surveys are associated with high variability and are not considered indicative of population trends. Standardized commercial CPUE shows much interannual variability before 1982. Since 1982 there has been a general decline in this index. The year-classes of the early 1980s are dominant in the fishery.

**Fishing mortality:**

**Recruitment:** Relative length distributions indicate a pulse of recruitment that occurred in the spring 1991 survey at mode of 11-12cm corresponding to the 1988-89 year-classes. These year-classes comprised 14% of the research catch numbers in the 1992 fall survey. The magnitude of these year-classes is unknown but should start recruiting to the fishery by 1996.

**State of the Stock:** There is no information to determine stock size. The CPUE index is indicating a general decline since 1982 and the contribution expected from the 1988-89 year-classes is unknown. There is no information to precisely estimate fishing mortality or exploitation rate generated by catches that have been in the range of 11,000t since 1989.

**Environmental Factors:**

**Multi-species Considerations:**

**Long-term Prospects:** Redfish stocks are noted for recruitment occurring only periodically. This leads to wide fluctuations in stock abundance. Given that the incidence of strong year-classes is infrequent and that growth rates are very low, fishing mortalities on redfish stocks must be maintained at low levels.

## 2.31. REDFISH IN LAURENTIAN CHANNEL SUMMARY

Year - Année	1986	1987	1988	1989	1990	1991	1992	1993	Min. <sup>1</sup>	Med. <sup>1</sup>	Max. <sup>1</sup>
Reference level - Niveau de référence '000t								25			
TAC - TPA '000t	-	-	-	-	-	-	25 <sup>2</sup>	25	25	25	25
Rep.catches-Prises décl. '000t	11	14	11	15	15 <sup>3</sup>	20 <sup>3</sup>	17 <sup>3</sup>	-	8	25	58
Unreported catches Prises non-déclarées											
Est.discards - Rejets est.											
Tot.catches - Prises Tot.											
Tot.biomass-Biomasse Tot.											
Sp.biomass-Biomasse Rep.											
Mean - F - Moyen											
<sup>1</sup> For 1960-1992 except TAC which is only for 1992-93 <sup>2</sup> Interim TAC advised for this revised management unit <sup>3</sup> Preliminary statistics/Statistiques provisoires											

**Forecast for 1994:** Catch rates will decline somewhat until recruitment of the 1984-85 year-classes enters the fishery.

**Catches:** Catches ranged from 8,100t (1984) to 58,000t (1971). Catches were in the vicinity of 20,000 t from 1960-1968, increased to an average of 43,000t from 1969 to 1975 then declined steadily to the lowest on record in 1984 at 8,100t. Since 1984, landings increased steadily to 20,000t in 1991. The 1992 catch was 17,000t.

**Data and Assessment:** The standardized catch rate series shows large increases in 1989 and again in 1990 followed by successive decreases in 1991 and 1992. These are considered too dynamic to reflect changes in abundance. Research vessel trawl surveys are not considered reflective of stock abundance. Production models using catch and standardized effort did not result in reliable parameter estimates.

#### Fishing Mortality:

**Recruitment:** Length frequencies from the 1993 February research survey in Div. 3Ps show two modes, one at 14-15 cm which corresponds to the 1987-88 year-classes and another at 21-23 cm which corresponds to the 1984-85 year-classes. Both of these year-classes have yet to recruit to the fishery. These pulses together represented about one third of the research catch.

**State of the Stock:** There is no information to determine estimates of stock size in 1993. The stock appears healthy with the good year-classes of the early 1980s well represented in the fishery. The exploitable stock should also be augmented by the year-classes of 1984-85 and 1987-88 in the mid-1990s and again near the turn of the century. There is no information to precisely estimate fishing mortality or the exploitation rate generated by catches that have been in the vicinity of 18,000 t for 1991 and 1992.

#### Environmental Factors:

#### Multi-species Considerations:

**Long-term Prospects:** Redfish stocks are noted for recruitment occurring only periodically. This leads to wide fluctuations in stock abundance. Given that the incidence of strong year-classes is infrequent and that growth rates are very low, fishing mortalities on redfish stocks must be maintained at low levels.

## 2.32. WHITE HAKE IN 4T SUMMARY

Year - Année	1986	1987	1988	1989	1990	1991	1992	1993	Min.	Med.	Max.
Reference level - Niveau de référence	12	-	5.5	5.5	N/A	N/A	N/A	5.5			
TAC - TPA '000t	12	9.4	5.5	5.5 <sup>1</sup>	5.5	5.5	5.5	5.5	12.0 <sup>1</sup>	5.5 <sup>1</sup>	5.5 <sup>1</sup>
Rep.catches-Prises décl. '000t	5	6.4	3.9	5.3	4.9 <sup>2</sup>	4.1 <sup>2</sup>	3.5 <sup>2</sup>		14.0 <sup>1</sup>	3.5 <sup>1</sup>	6.1 <sup>1</sup>
Unreported catches Prises non-déclarées											
Est.discards - Rejets est.											
Tot.catches - Prises Tot.											
Tot.biomass-Biomasse Tot.											
Sp.biomass-Biomasse Rep.											
Mean - F - Moyen											
<sup>1</sup> For/Pour 1982-1992 <sup>2</sup> Preliminary statistics/Statisques provisoires											

**Forecast for 1994:** The precautionary TAC of 5,500t appears to represent a high rate of exploitation. However, given the uncertainties about stock definition, there is no firm basis to suggest a modification of the 5,500t TAC.

**Catches:** Since 1970, the average annual catch of white hake has been 6,100t. During this time, catches have declined from a maximum in 1981 (14,039t) to a minimum in 1992 (3,547t), with the greatest decline occurring in the gillnet component. The majority of the landings (80%) are taken in the Northumberland Strait, off the western end of P.E.I. and between P.E.I. and Cape Breton Island in July and August.

**Data and Assessment:** An SPA assessment has not been conducted since 1989 due to the lack of a reliable index of abundance and because of concerns about stock definition within the 4T management unit.

**Fishing Mortality:** An analysis of estimates of instantaneous mortality rates from the 1992 research surveys, suggested that fishing mortality has probably been high (approx. 1.0) during the past several years.

**Recruitment:** Indications from the commercial fishery and research vessel survey are that recruitment has not been above average.

**State of the Stock:** The research survey data indicates that recruitment has not been above average and that fishing mortality appears to be high. Fewer old white hake were caught in 1990 and 1991, making this fishery even more dependent on a few age classes than in the past. As a result, this fishery will be sensitive to annual fluctuations in recruitment. Research vessel estimates of population abundance and biomass for 1990 and 1991 were below average for the period 1986-1991.

### Environmental Factors:

**Multi-species Considerations:** White hake are frequently caught by inshore trawlers targeting winter flounder in the Northumberland Strait.

**Long-term Prospects:** Catches from this resource have averaged 6,100t since 1970 but have declined to a minimum of 3,547t in 1992. Indications are that recruitment has been below average since 1990 and that fishing mortality has been high. Recovery of this resource will depend on the occurrence of favourable recruitment.

Cod in 2J-3KL

Fig. 1.1a. Total catches (t) and TACs (t)

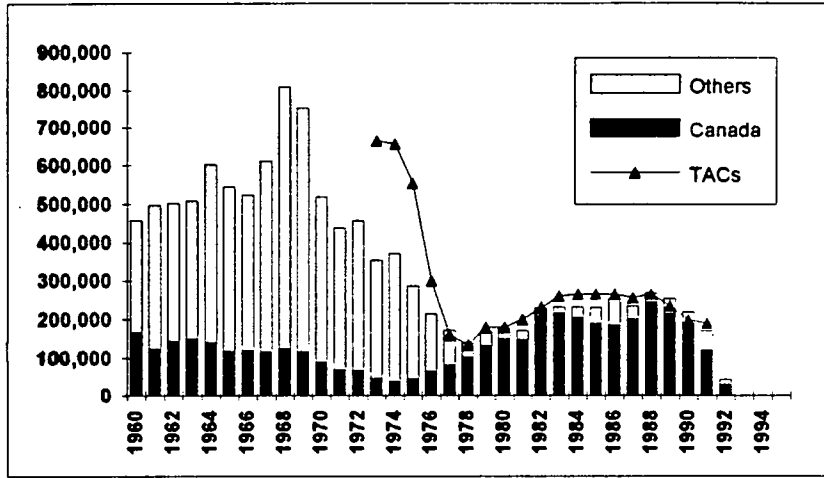
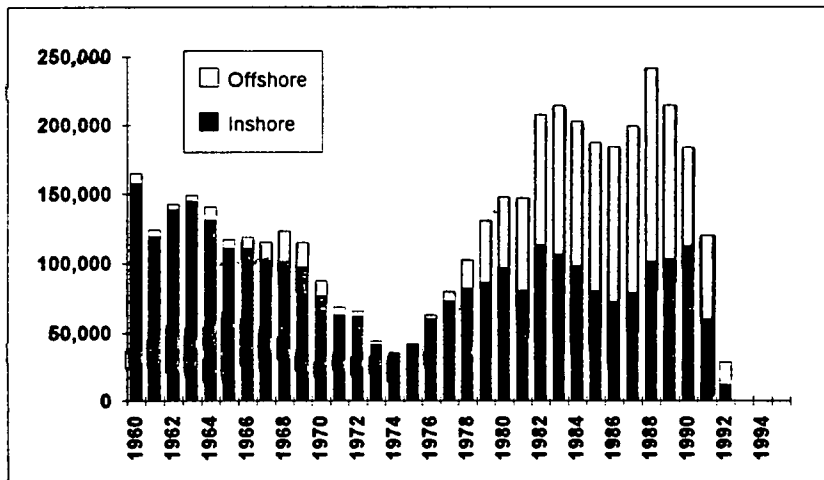
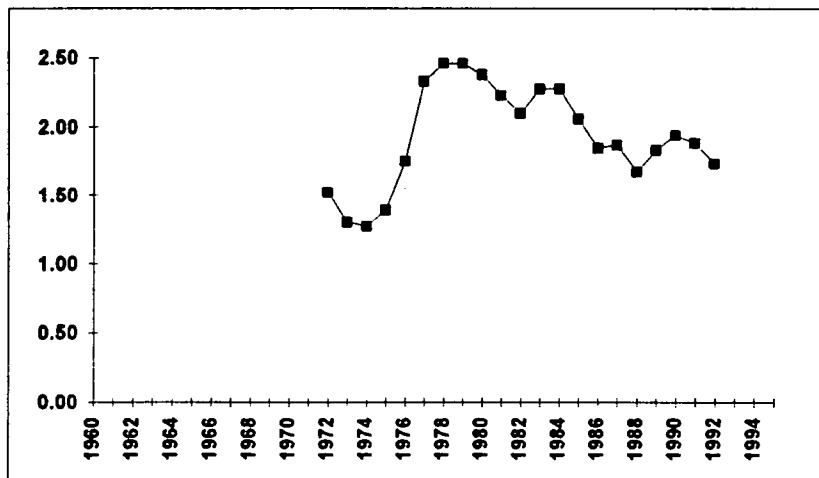

Fig. 1.1b. Inshore and Offshore Canadian Catches (t)



Cod in 2J-3KL

Fig. 1.1c. Mean Weight (kg) at age 7





Cod in 2J-3KL

Abundance Indices

Fig. 1.1d.

RV Abundance - 2J ('000)

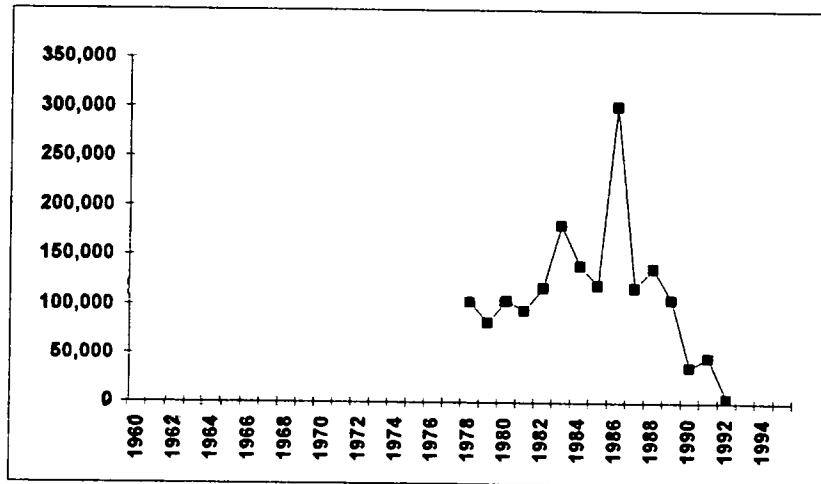

RV Biomass - 2J (t)

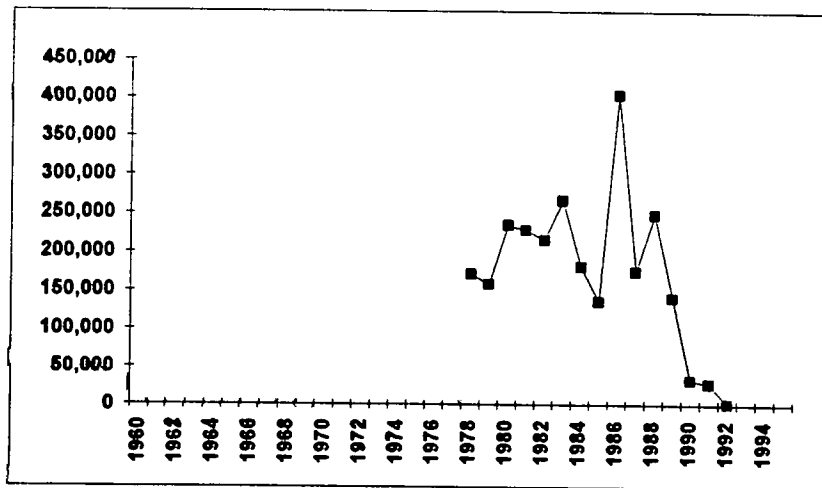

Cod in 2J-3KL

Abundance Indices

Fig. 1.1a. RV Abundance - 3K ('000)

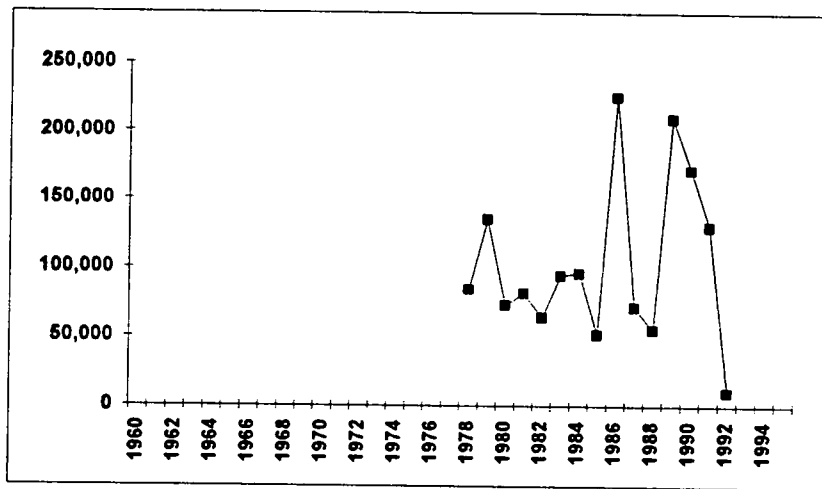

RV Biomass - 3K (t)

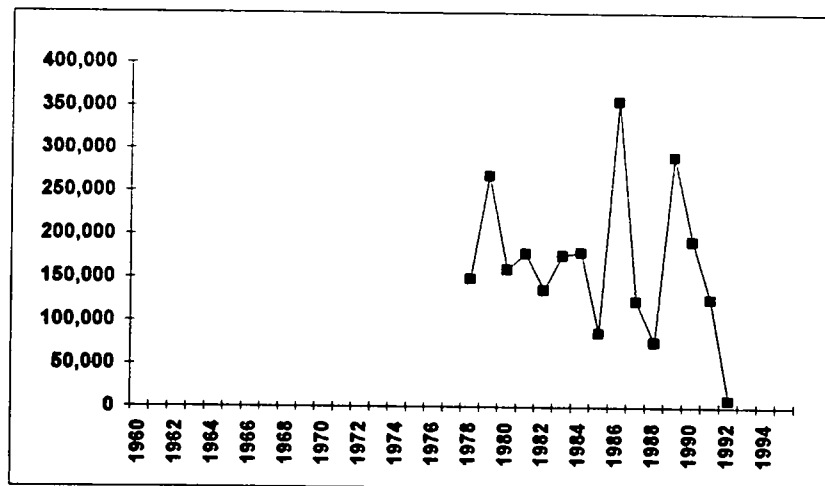

Cod in 2J-3KL

Abundance Indices

Fig. 1.1f.

RV Abundance - 3L ('000)

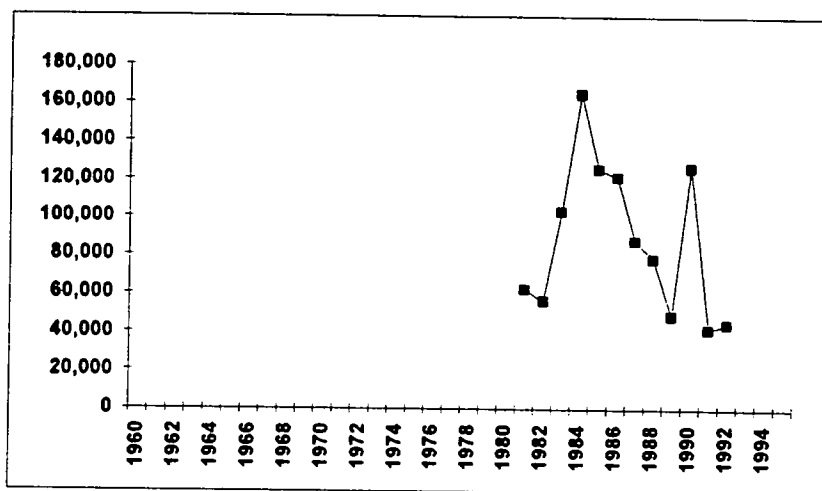

RV Biomass - 3L (t)

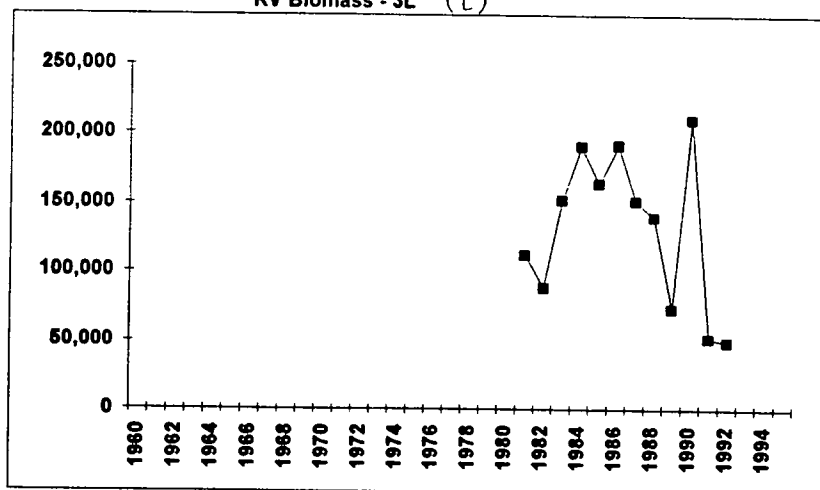

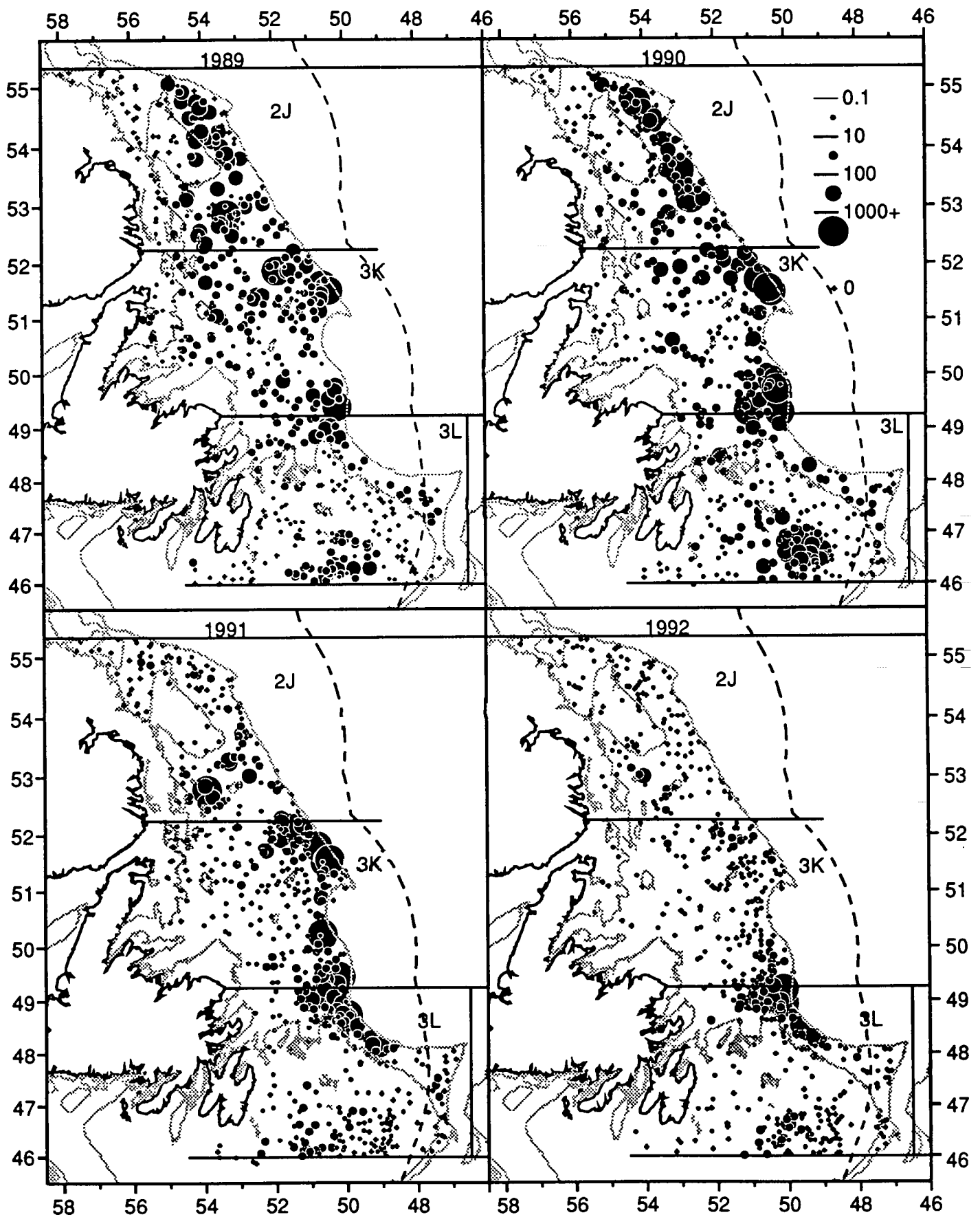
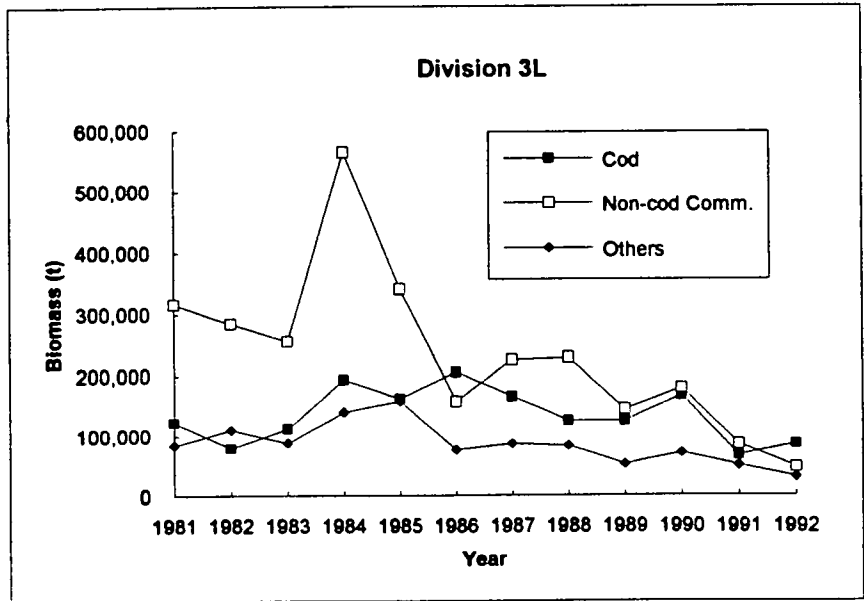
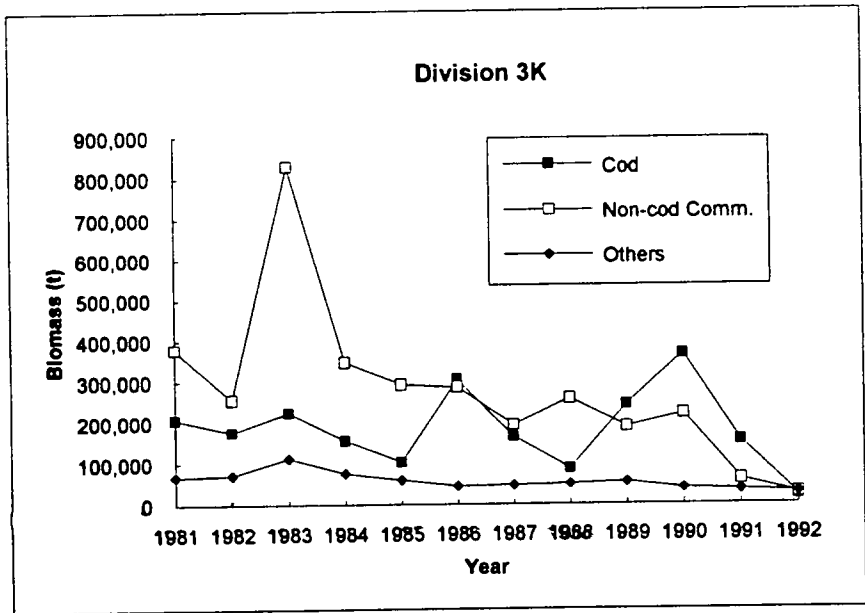
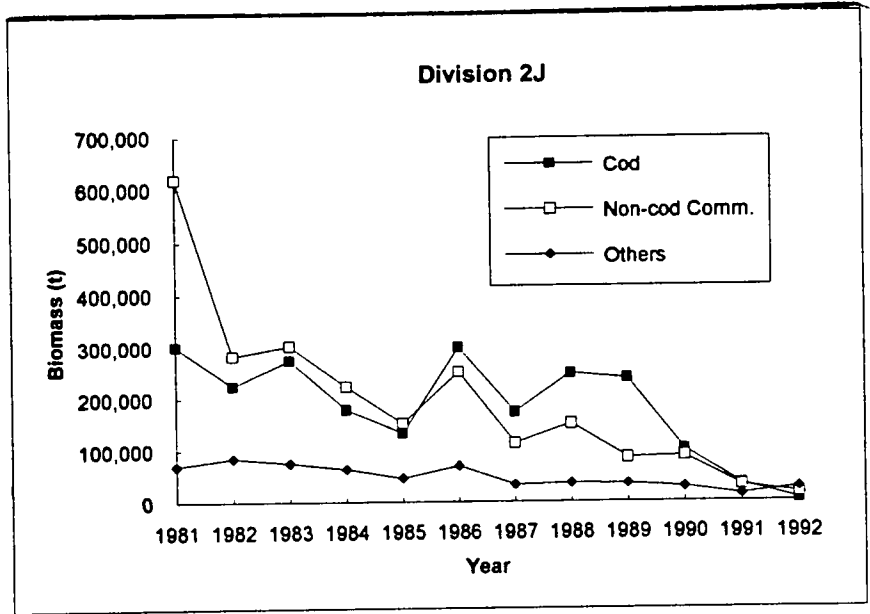

Figure 1.1g. Cod Distribution 1989-1992 from Autumn 2J3KL RV Surveys, Numbers per Tow.



Cod in 3Ps

Fig. 1 .2a. Total catches (t) and TACs (t)

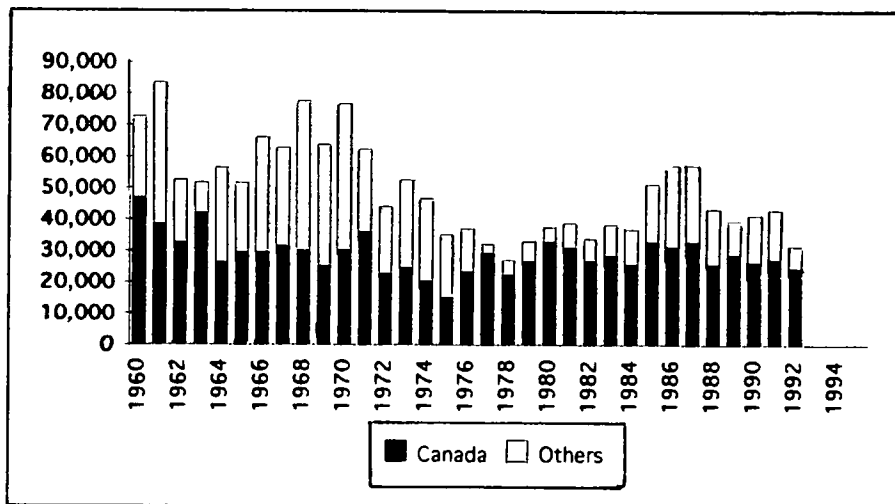
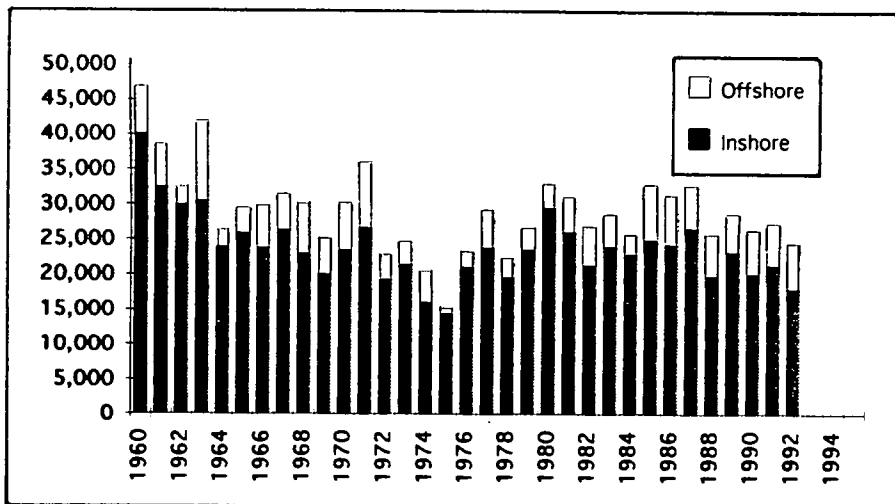

Fig. 1 .2b. Inshore and Offshore Canadian Catches (t)



Cod in 3Ps

SPA

Fig. 1.2c. Mean Weight (kg)

at age 7

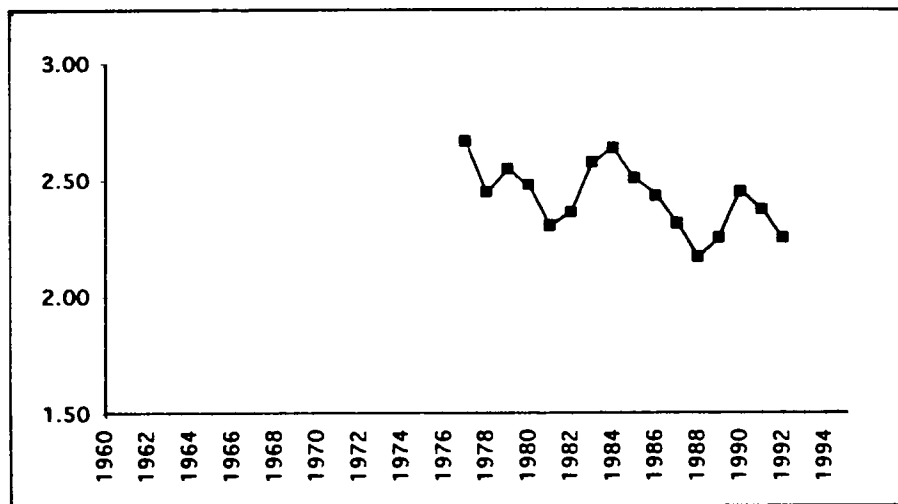

Fig. 1.2d.

RV Canada (kg/tow)

All ages

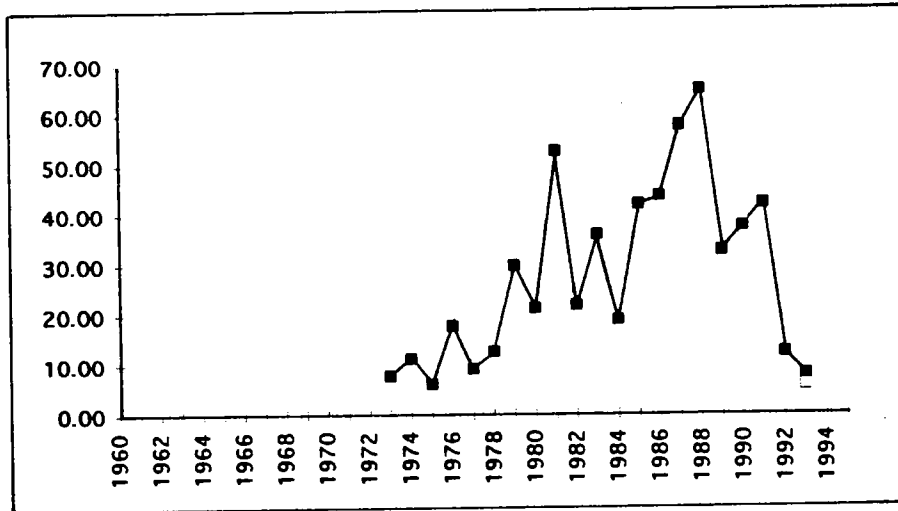
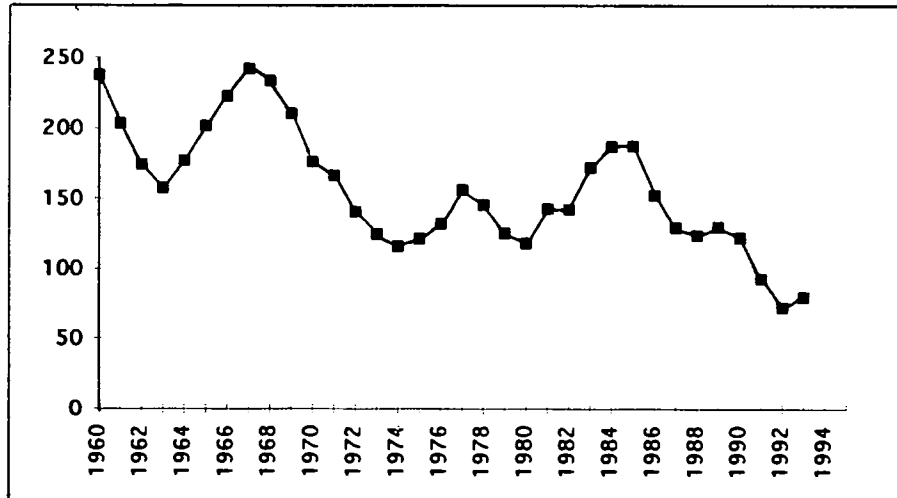

Fig. 1.2e.

Total Abundance (million)

3+



Cod in 3Ps

SPA

Fig. 1.2f.

Annual fishing mortality rates.

6+

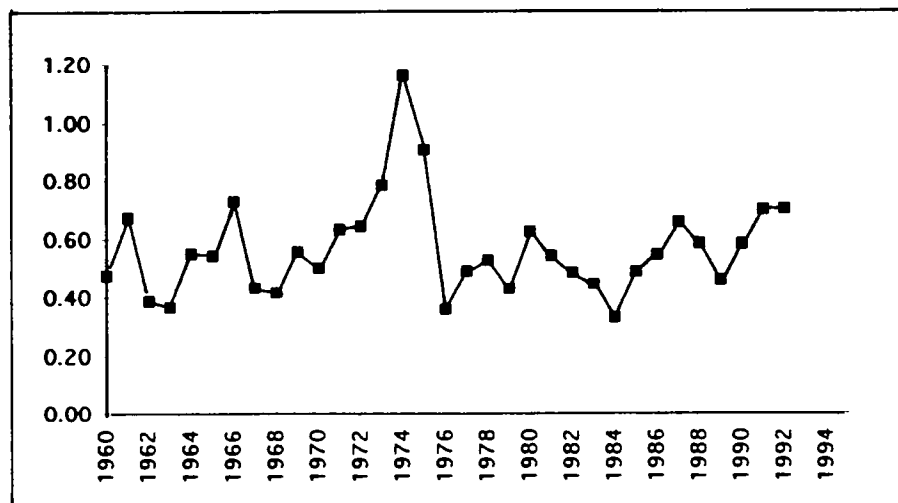

Fig. 1 .3a. Total catches (t) and TACs (t).

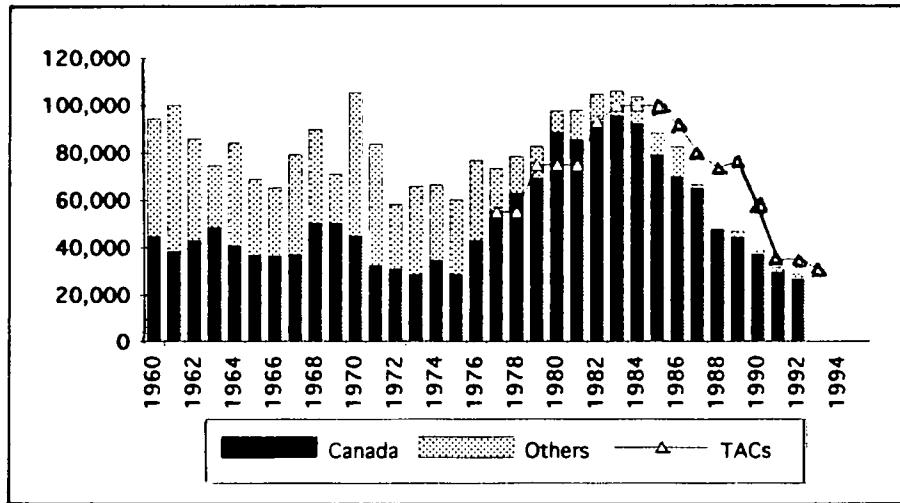

Fig. 1 .3b . Fixed and Mobile Sectors: Canadian Catches (t).

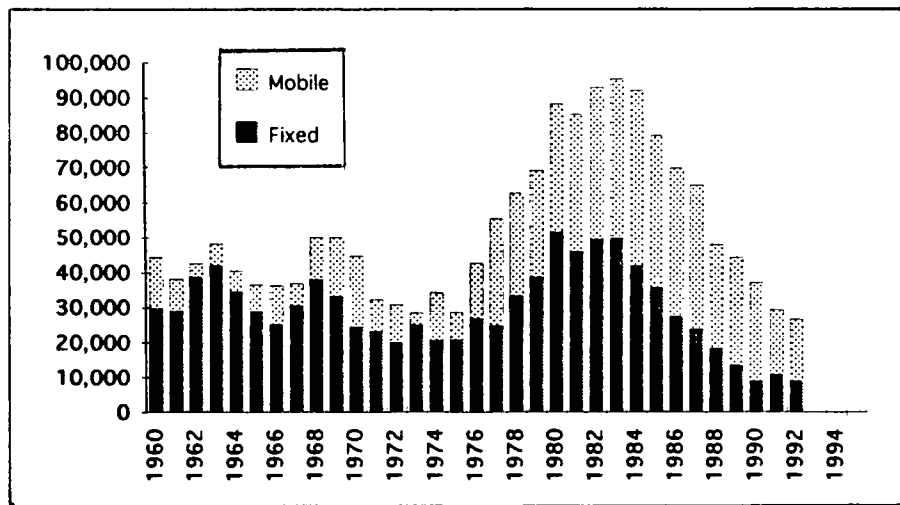

Fig. 1.3c. Mean Weight (kg).

at age 7

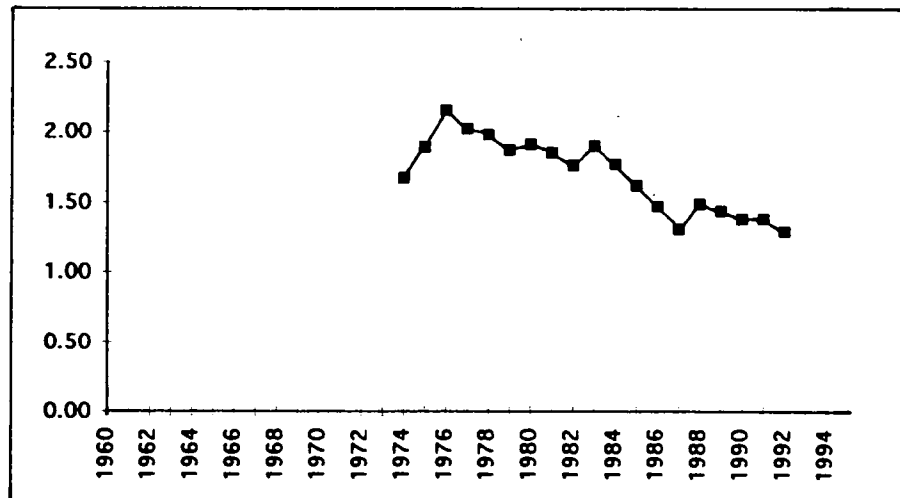
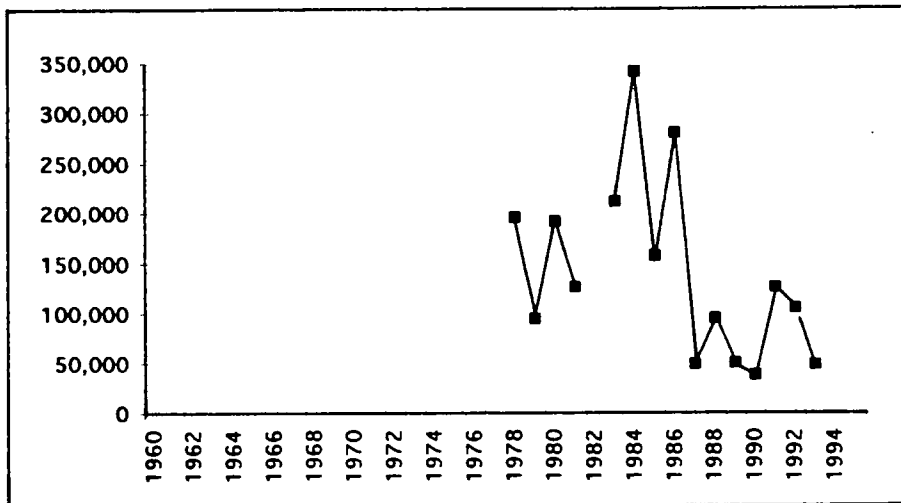



Fig. 1.3d. Biomass (t) - winter.

All ages



Cod in 3Pn-4RS

ADAPT

Fig. 1.3e. Total Abundance (million).

3+

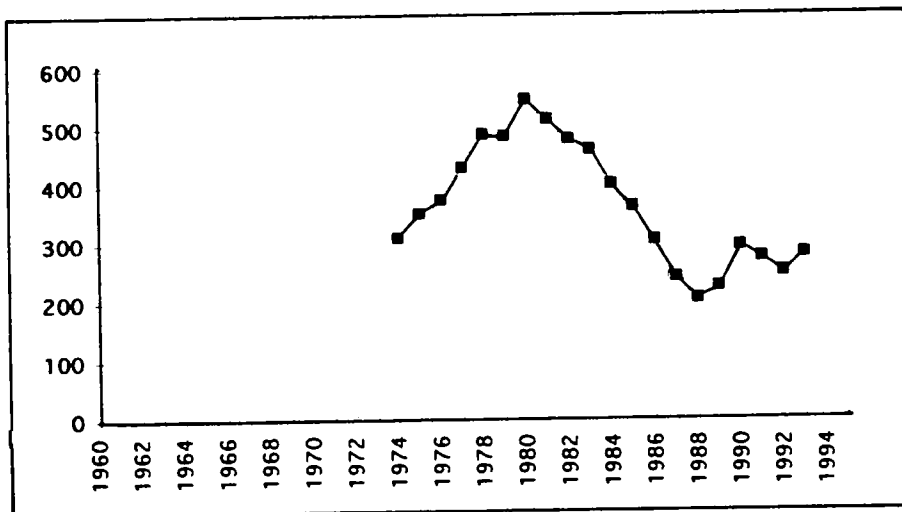

Fig. 1 .3f. Recruitment (million).

Age 3

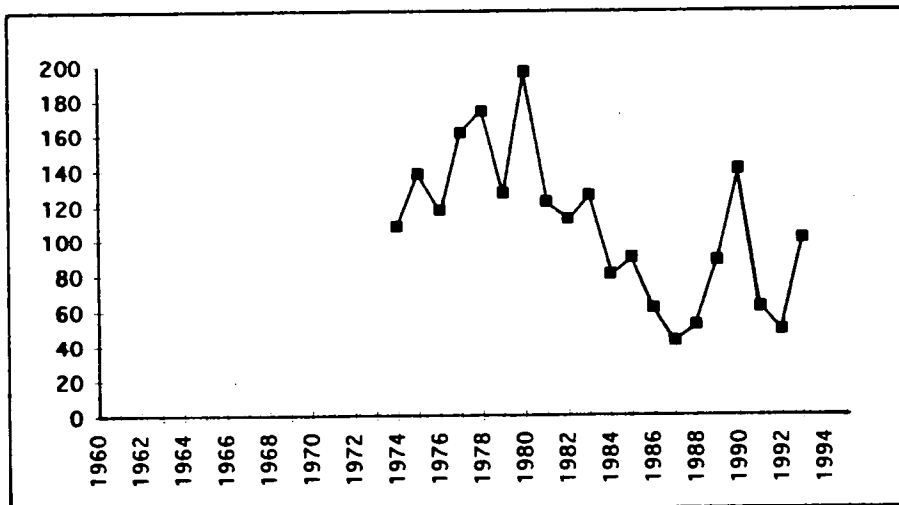

Fig. 1.3g. Total Biomass (thousand tonnes).

3+

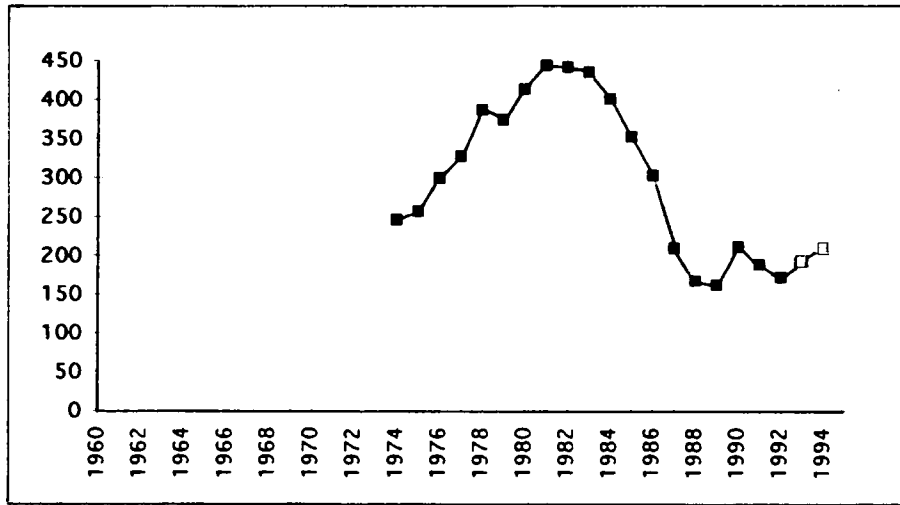

Fig. 1.3h. Adult Biomass (thousand tonnes).

7+

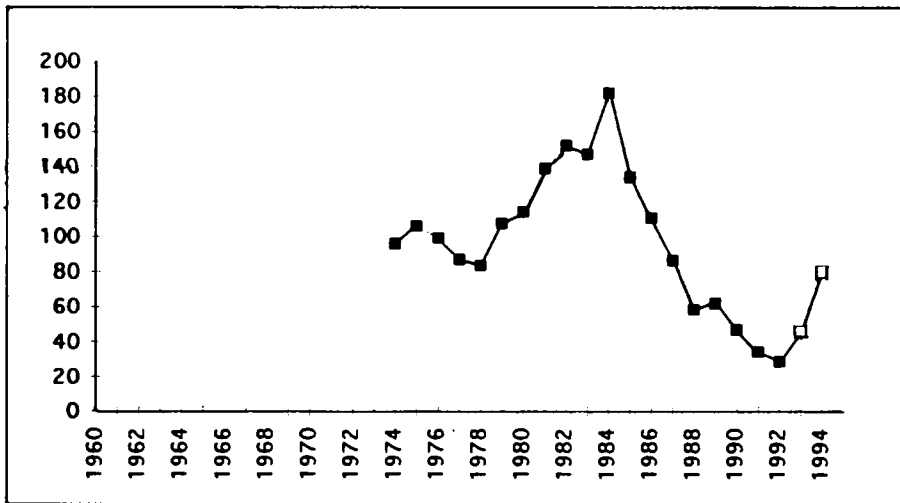

Fig. 1.3i. Fishing mortality rates.

(7-9)

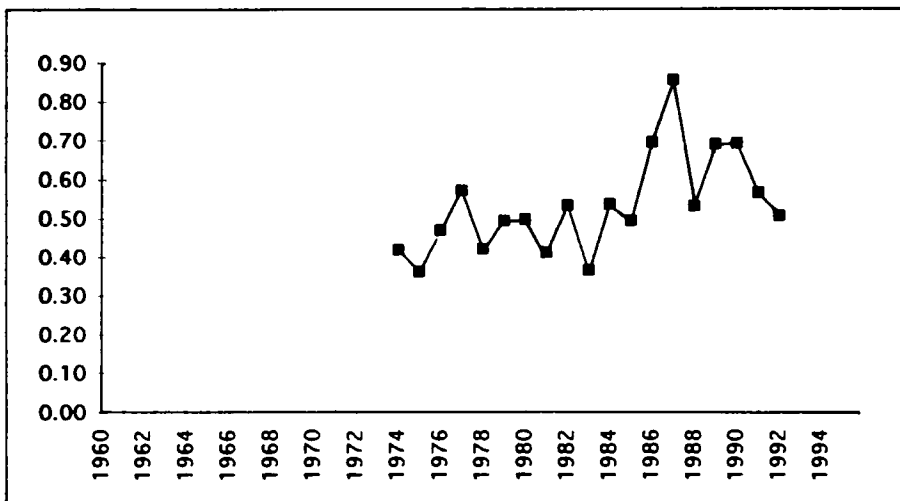
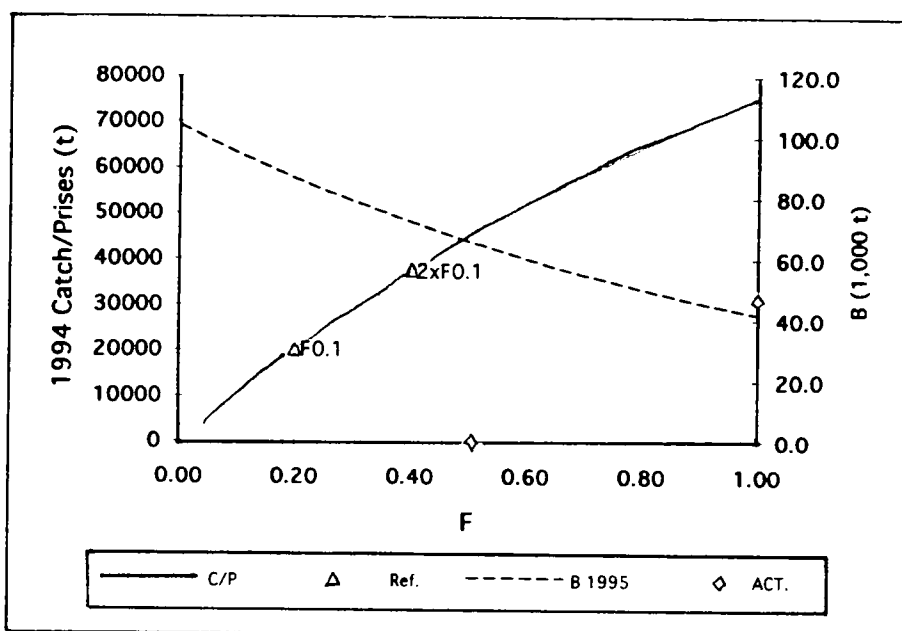

Fig. 1.3j. Cod - Morue: 3Pn-4RS

Projections



Cod in 4T-Vn (J.-A.)

Fig. 1.4a Total catches (t) and TACs (t).

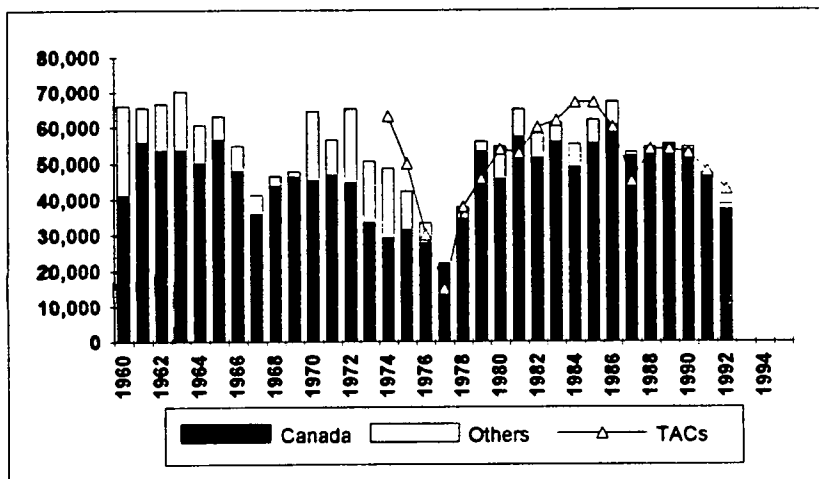
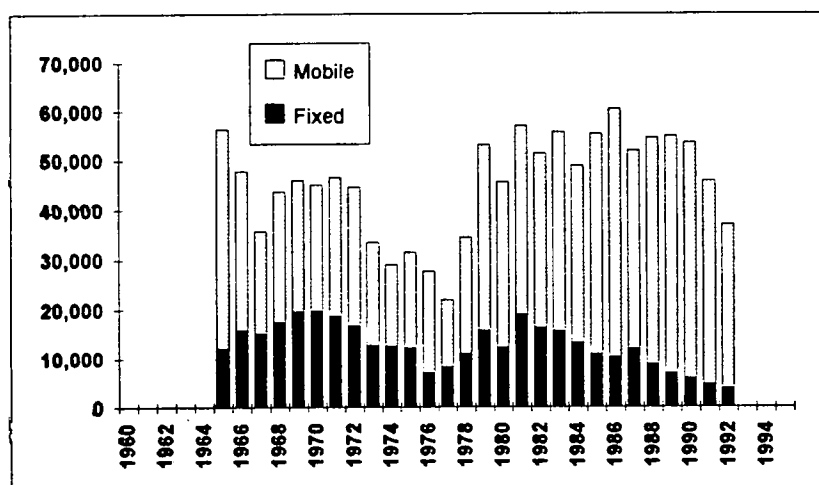

Fig. 1.4b. Inshore and Offshore Canadian Catches (t)



Cod in 4T-Vn (J.-A.)

Abundance Indices

Fig. 1.4c.

Mean Weight (kg)

at age 7

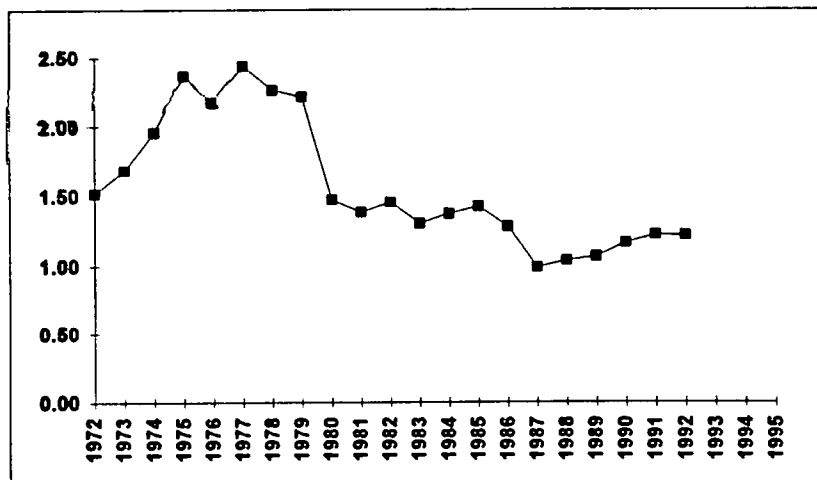
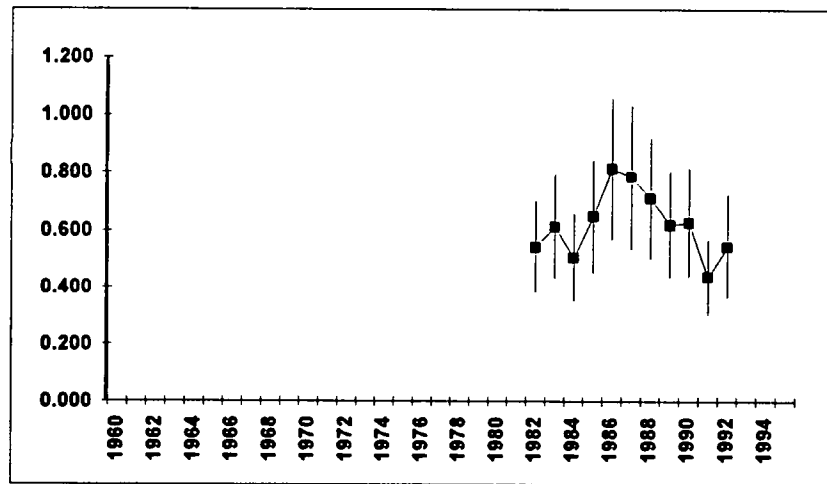

Fig. 1.4d. OT CPUE (t/hour)



Cod in 4T-Vn (J.-A.)

Abundance Indices

Fig. 1.4e.

RV (Nb/tow) - fall

3+

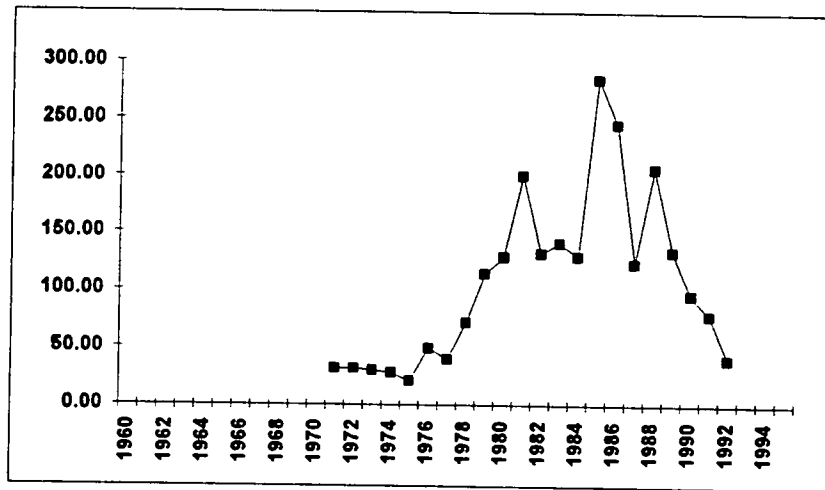

Fig. 1.4f.

RV (Nb/tow) - fall

5+

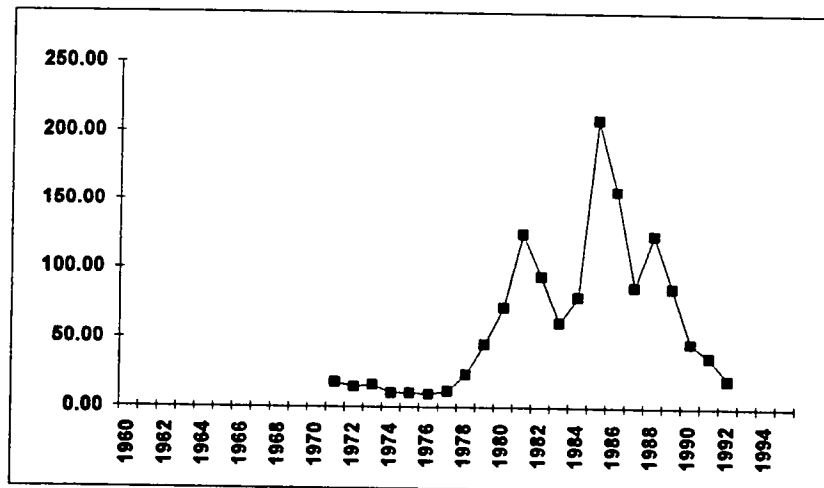
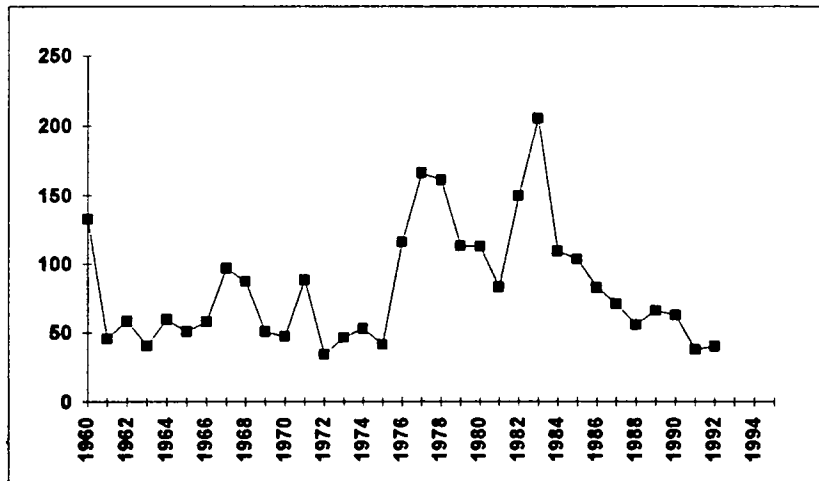

Fig. 1.4g.

Recruitment (million)

Age 3



Cod in 4T-Vn (J.-A.)

Hybrid

Fig. 1.4h.

Fishing mortality rates.

7+

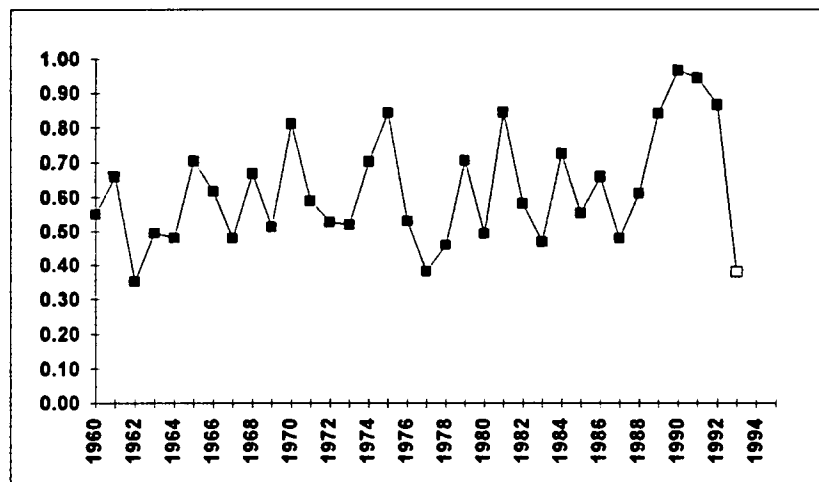
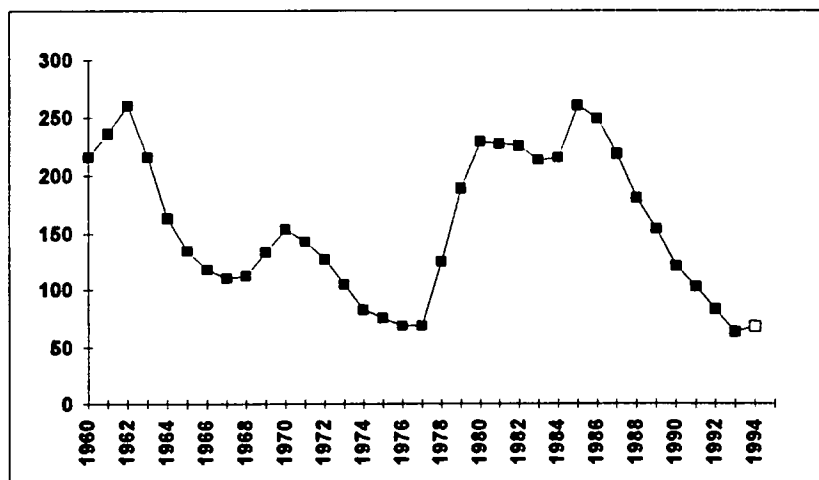

Fig. 1.4i.

Adult Biomass (thousand t)

5+



Cod in 4T-Vn (J.-A.)

Hybrid

Fig. 1.4j.

Total Biomass (thousand t)

3+

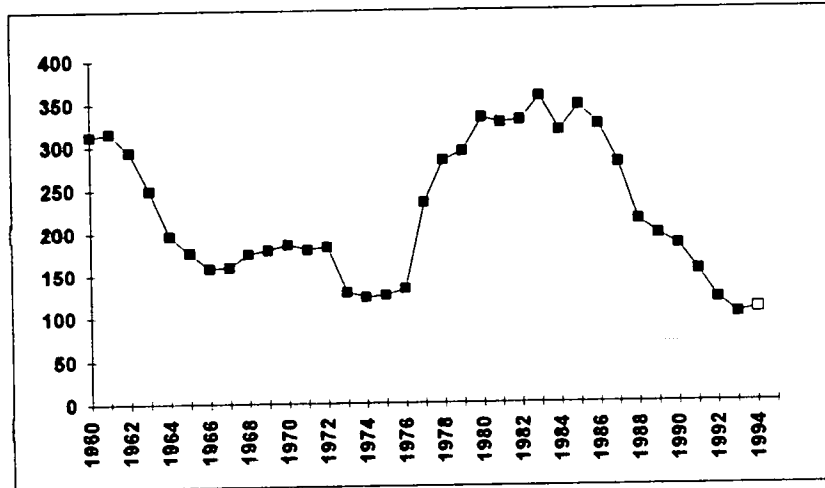

Cod in 4T-Vn (J.-A.)

Hybrid

Fig. 1.4k.

Total Abundance (million)

3+

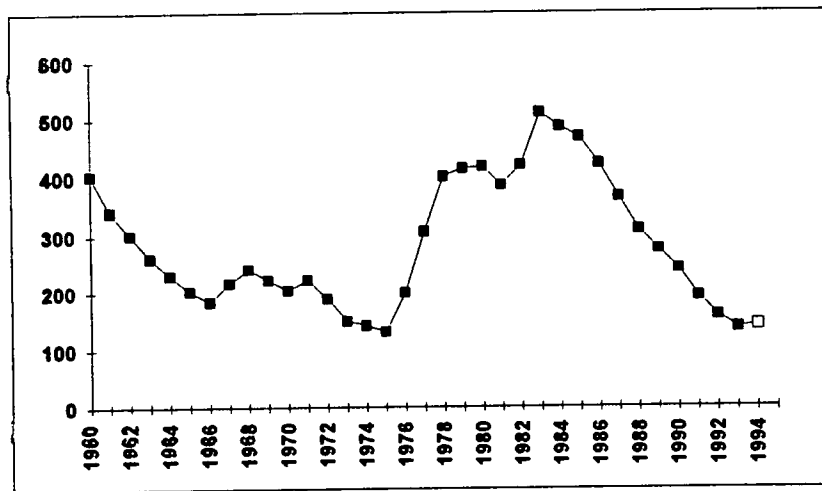
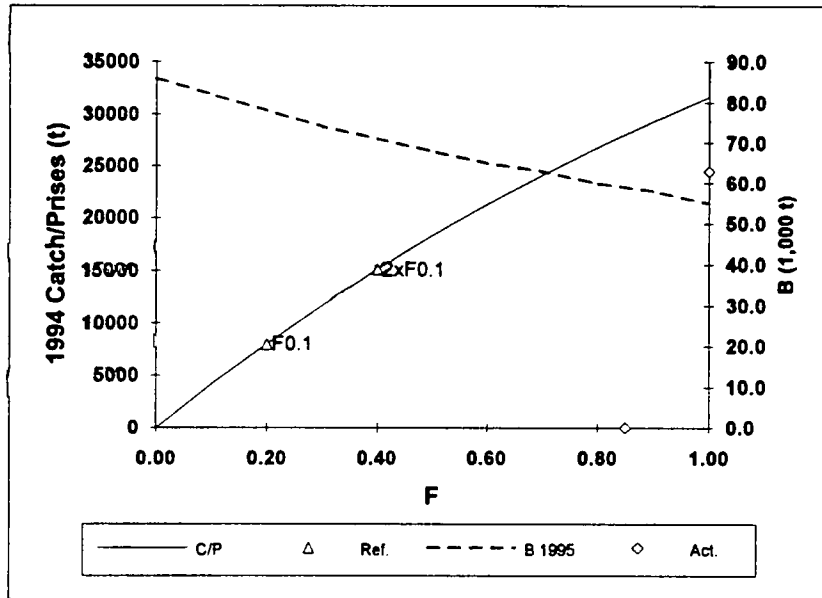

Fig. 1 .4l. Cod in 4T-4Vn(J.-A.) Projections



C/P = Catch - Prises  
 Ref. = Reference - Référence  
 B 1995 = Adult biomass at beginning of 1995 - Biomasse adulte au début de 1995  
 Act. = Actual - Actuel

F1992= 0.85



Cod in 4VsW

Fig. 1.5a. Total catches (t) and TACs (t)

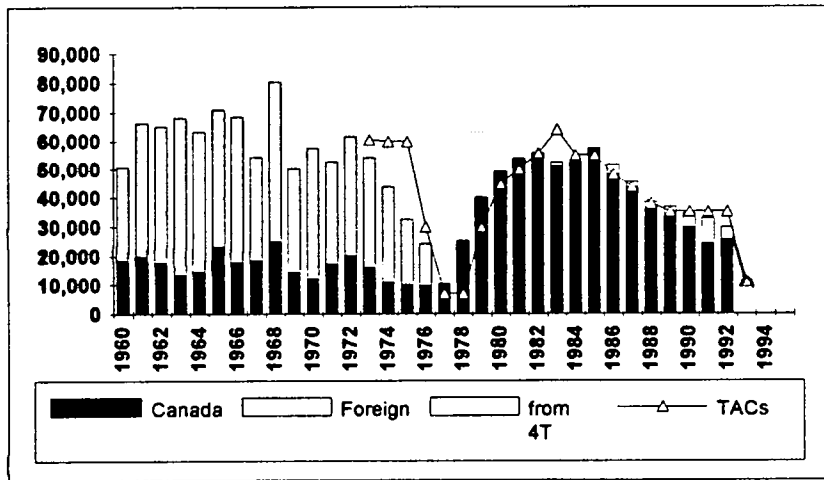
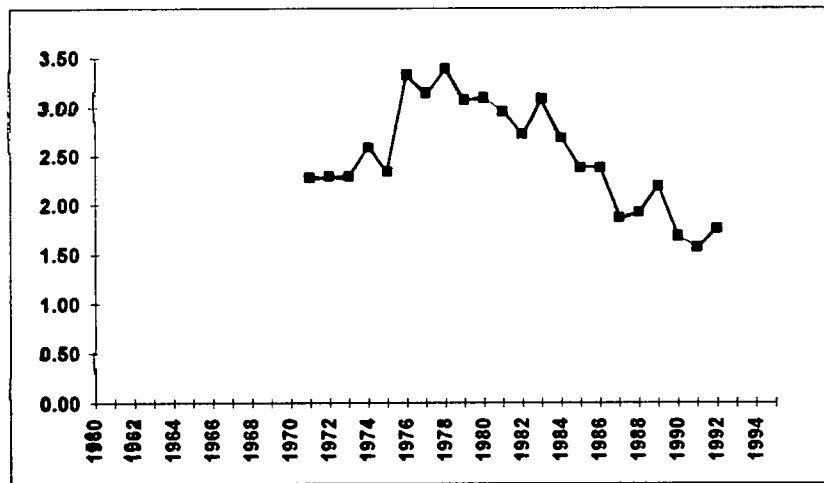

Fig. 1.5b. Mean Weight (kg) at age 7



Cod in 4VsW

Abundance Indices

Fig. 1.5c. CPUE (t/hour) - ZIF All ages

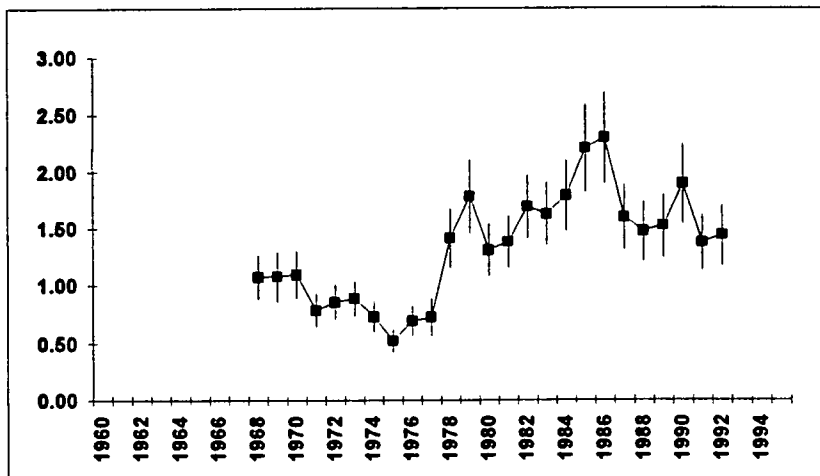
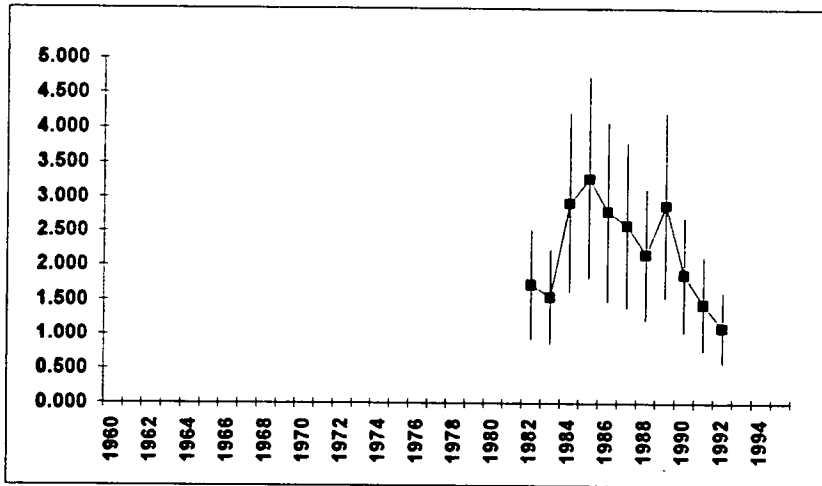

Fig. 1 .5d.

CPUE (t/hour) - IOP

All ages



Cod in 4VsW

Abundance Indices

Fig. 1 .5e.

RV (#/tow)

July

3+

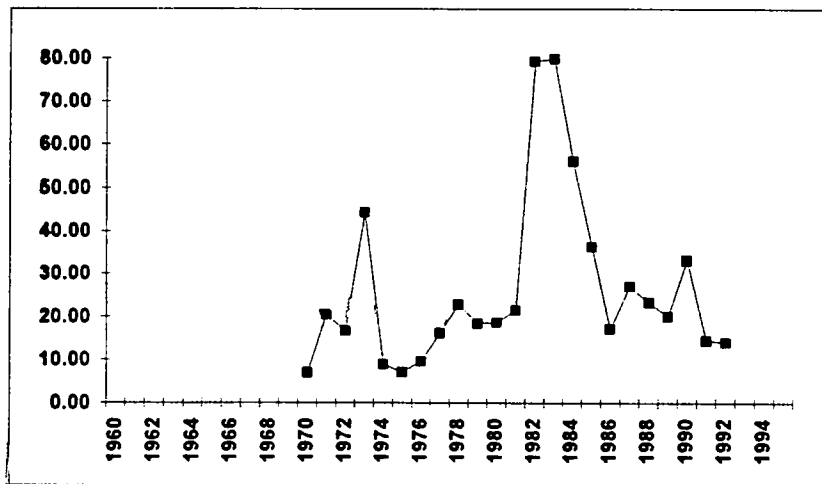
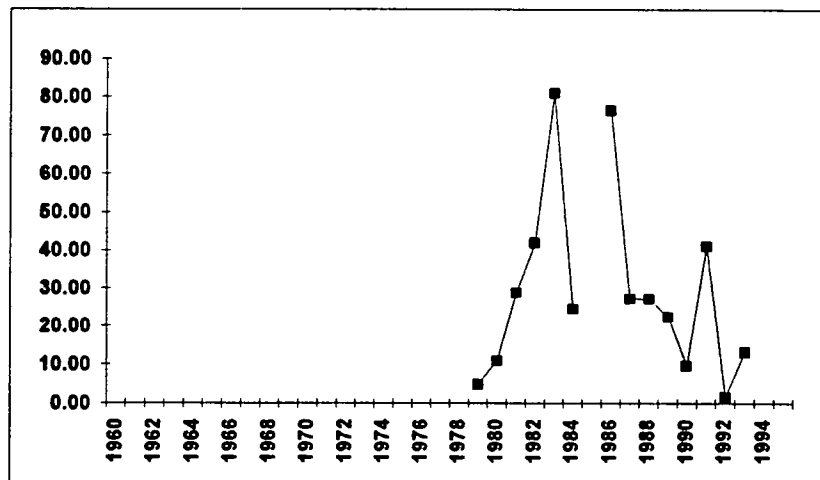

Fig. 1 .5f.

RV (#/tow)

Spring

3+



Cod in 4VsW

ADAPT

Fig. 1. 5g.

Fishing mortality rates.

7 to 9

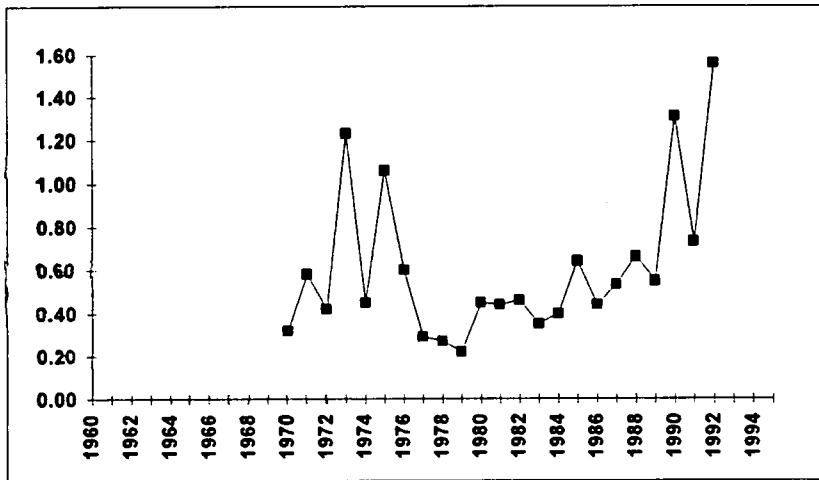

Cod in 4VsW

ADAPT

Fig. 1. 5h.

Total Biomass (thousand t)

1+

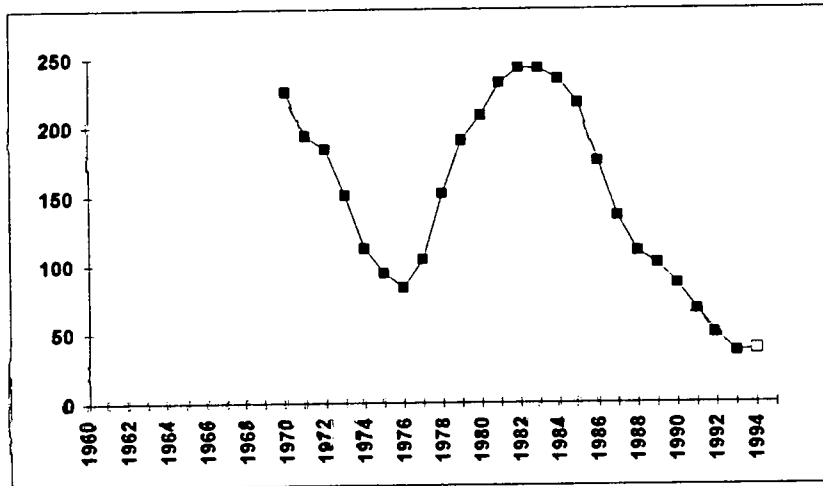

Fig. 1. 5i.

Adult Biomass (thousand t)

6+

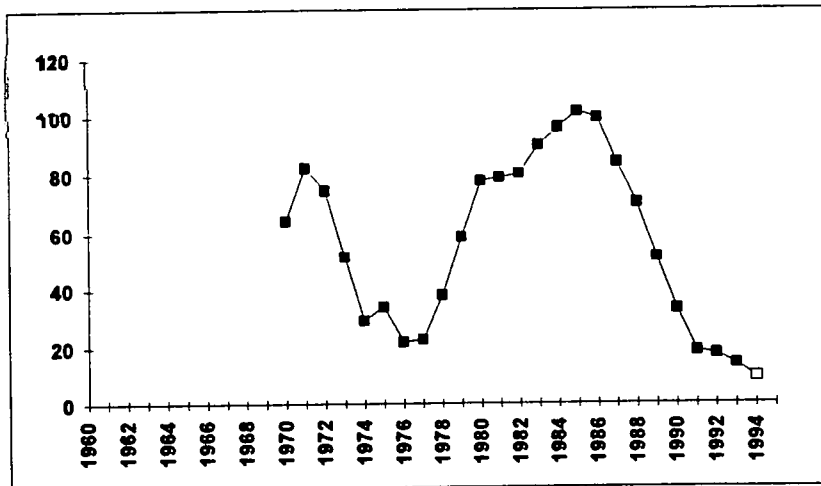

Fig. 1 .5j. Recruitment (million) Age 1

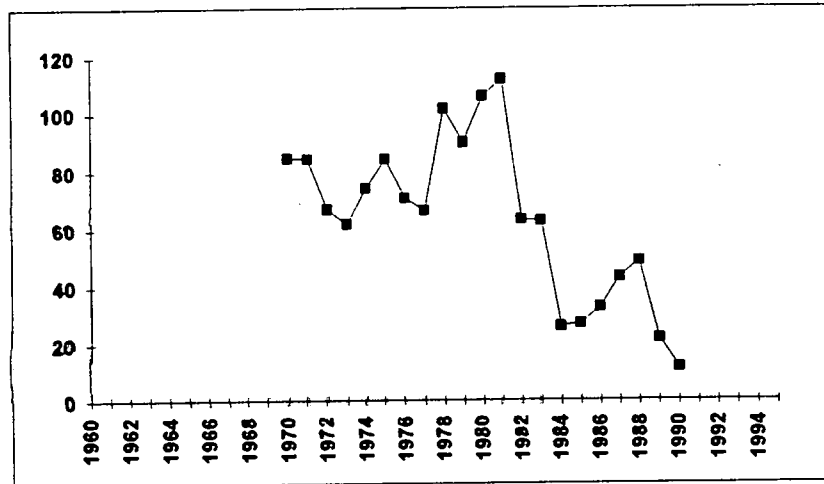

Fig. 1.5k. 4VsW cod numbers 3-8 from SPA surveys.

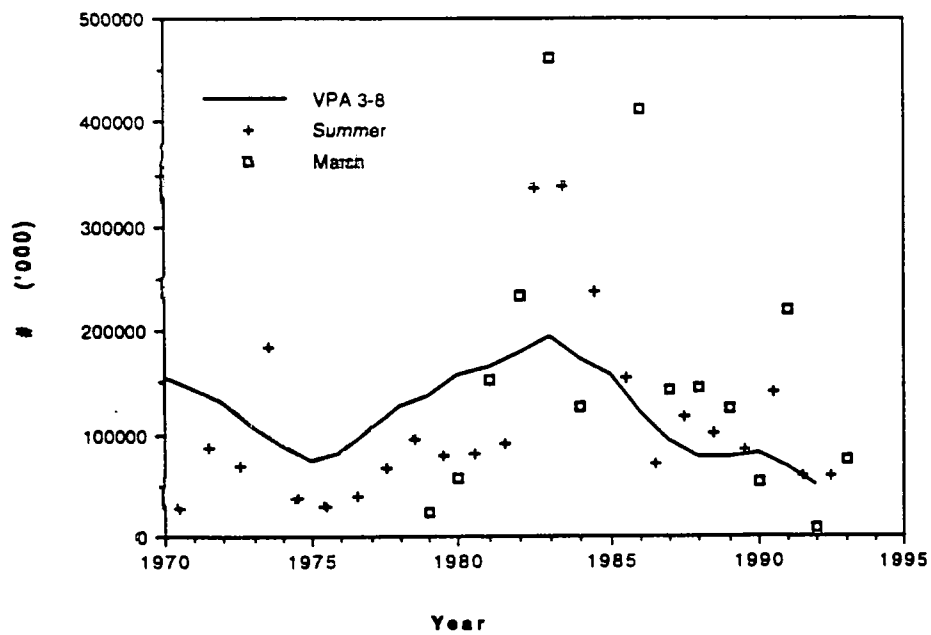
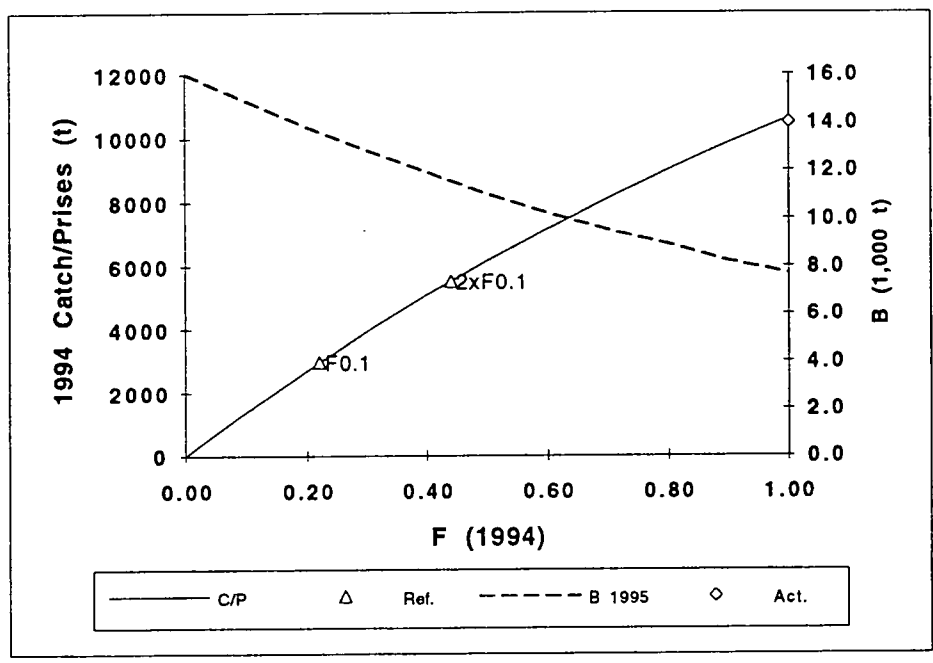

Fig. 1.5l. Cod - Morue: 4VsW

Projections



C/P = Catch - Prises  
 Ref. = Reference - Référence  
 B 1995 = Adult biomass at beginning of 1995  
 Biomasse adulte au début de 1995  
 Act.= Actual - Actuel

Fig. 1.5m. Long-term average vs. recent size frequencies from summer surveys.

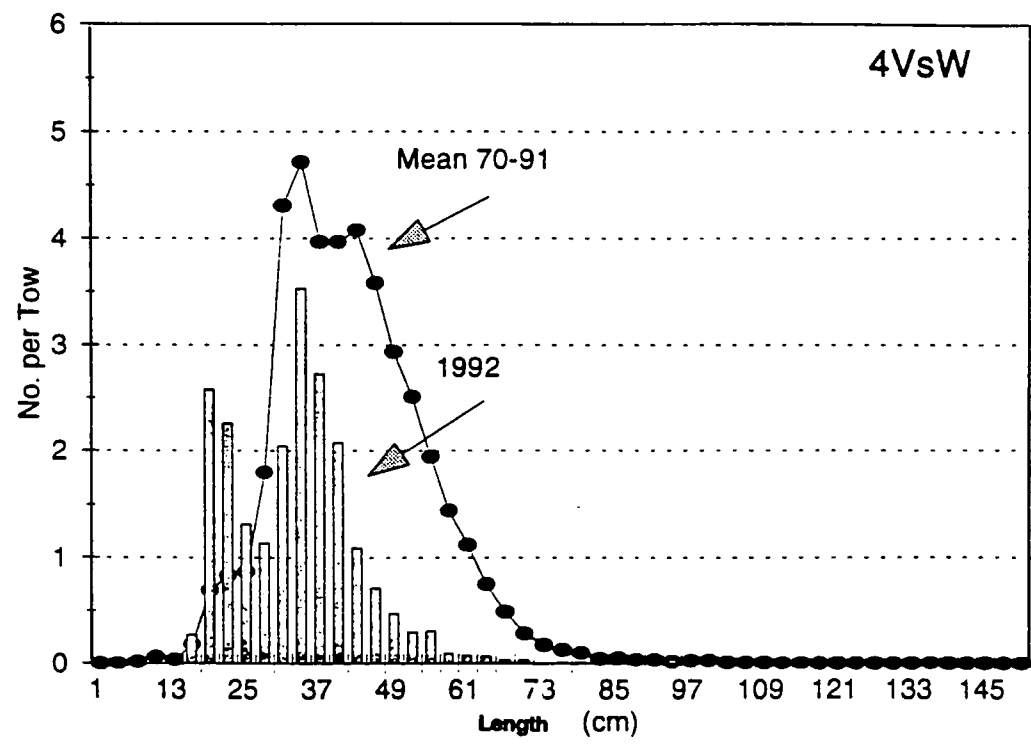
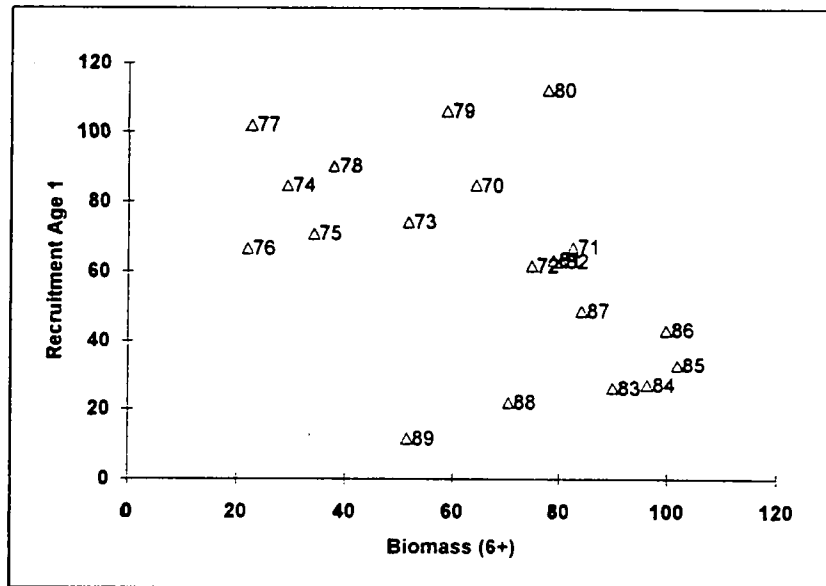

Fig. 1.5n. Cod in 4VsW - recruitment and adult biomass.



Labels identify year-class.

Cod in 4X

Fig. 1.6a. Total catches (t) and TACs (t)

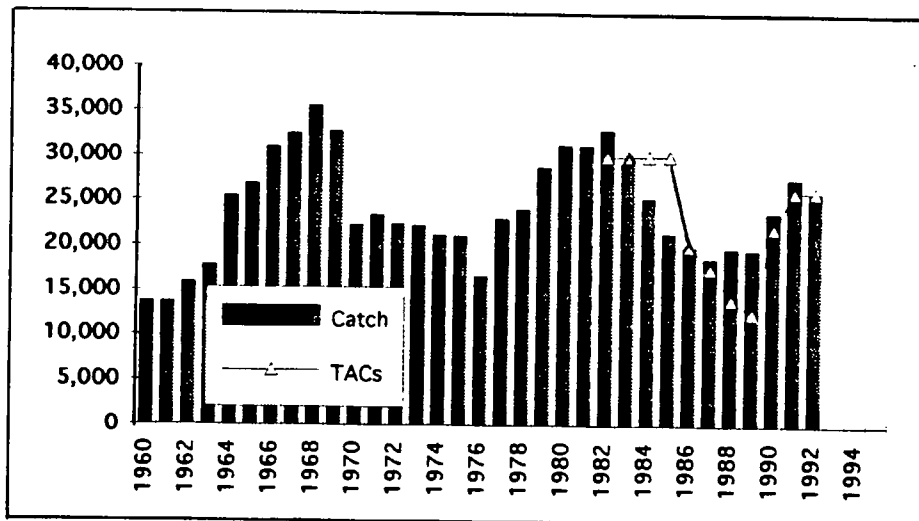

Fig. 1.6b.

Cod in 4X

SPA and RV (k adjusted) numbers (million)

Age 3-10

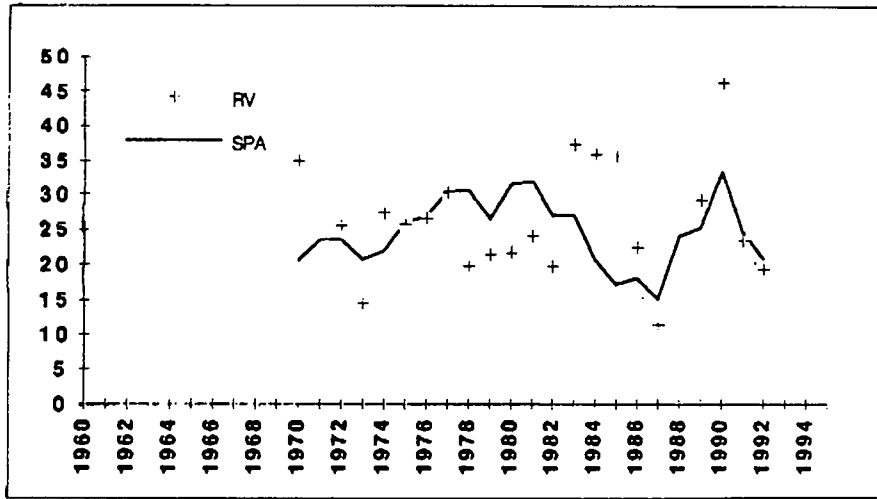

Fig. 1.6c.

Cod in 4X

Total Biomass (thousand tonnes)

1+

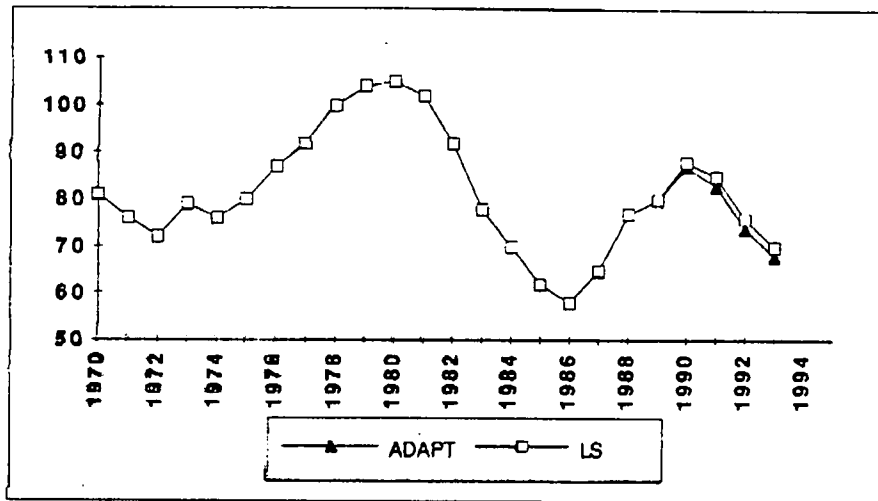
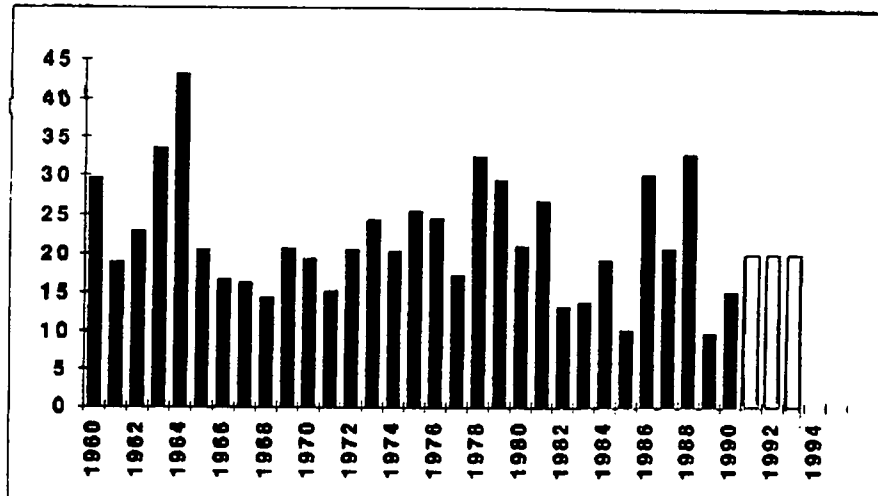

Fig. 1.6d.

Recruitment (million)

Age 1



Total Biomass (thousand tonnes)

1+

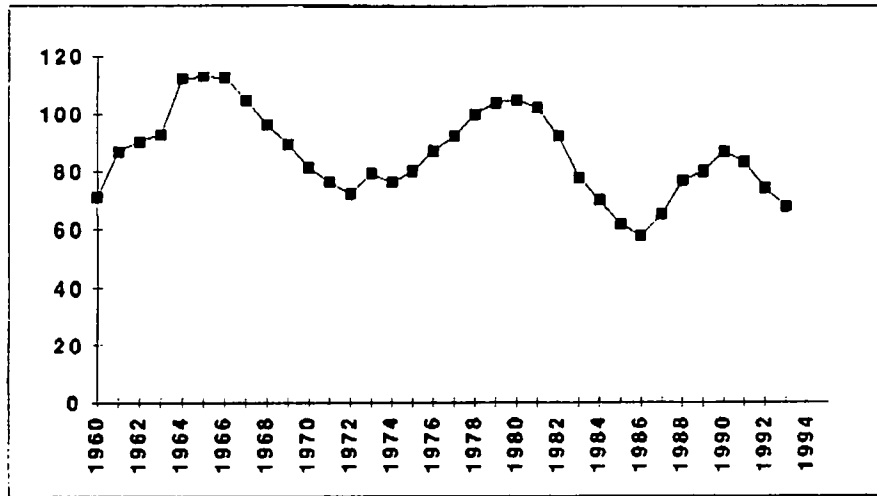

Spawning Biomass (thousand tonnes)

3+

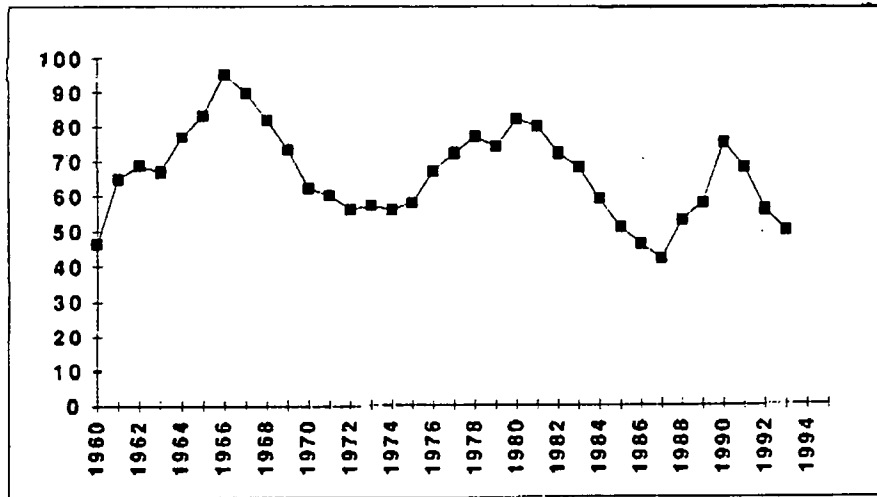

Fig. 10.6f.

Annual exploitation rates.

(4-6)

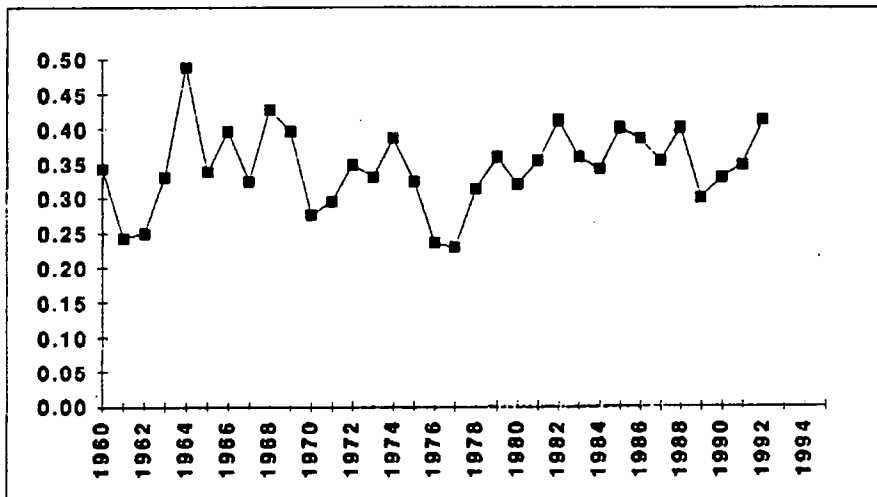



Fig. 1 .6g.

Cod in 4X

Projections

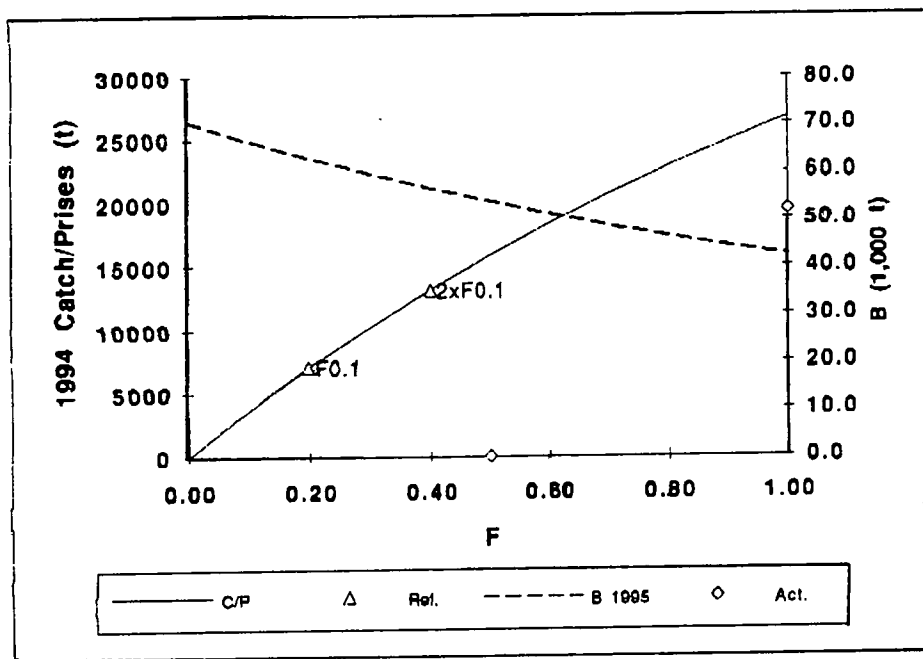
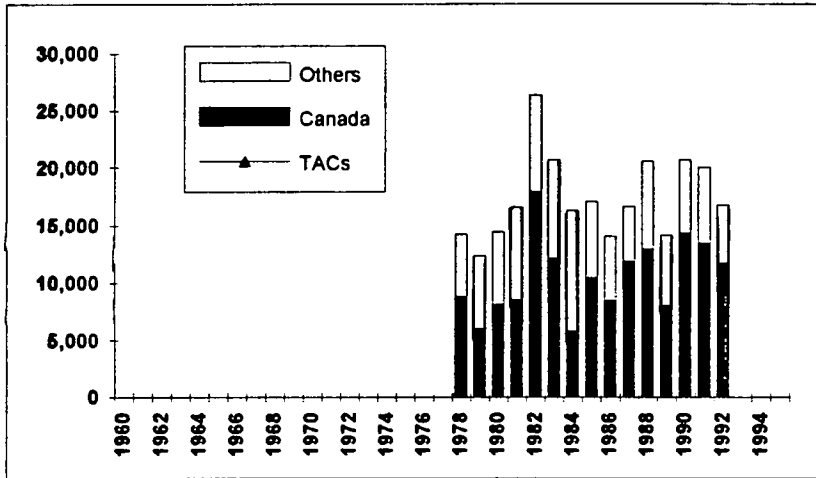

Fig. 1 .7a. Total catches (t) and TACs (t)



Cod in 5Zj,m

Fig. 1 .7b. Research vessel indices.

U.S.A. spring (nb/tow)

1+

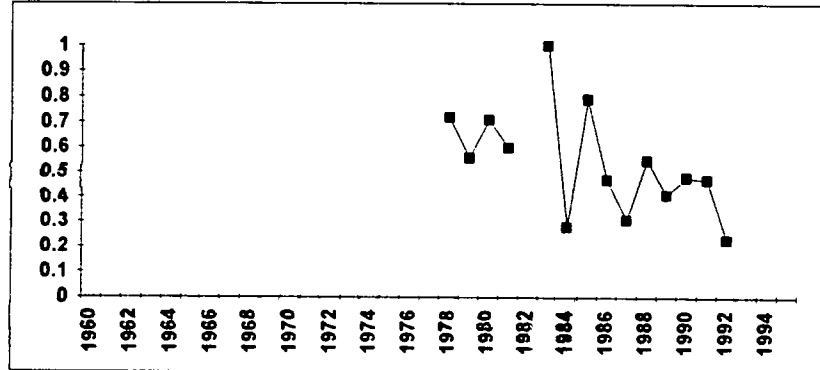

U.S.A. fall (nb/tow)

1+

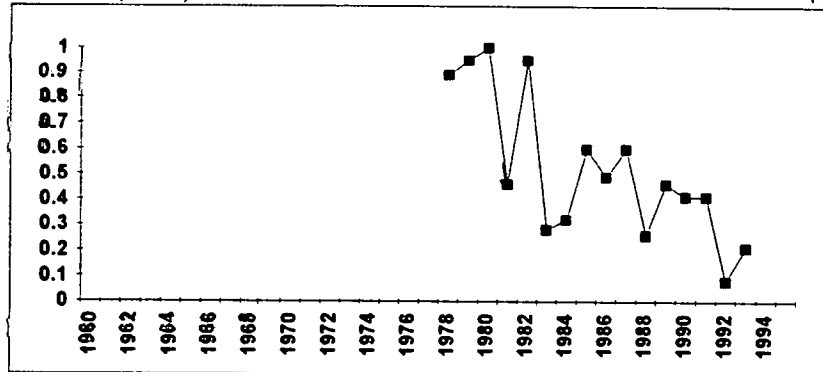

Canadian RV (nb/tow)

1+

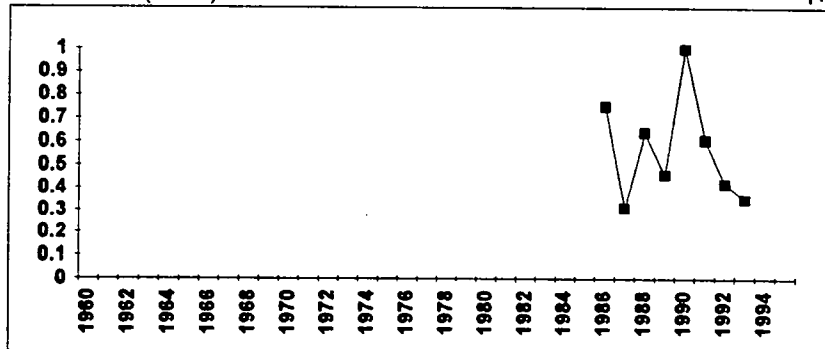

Haddock in 4TVW

Fig. 1 .8a. Total catches (t) and TACs (t)

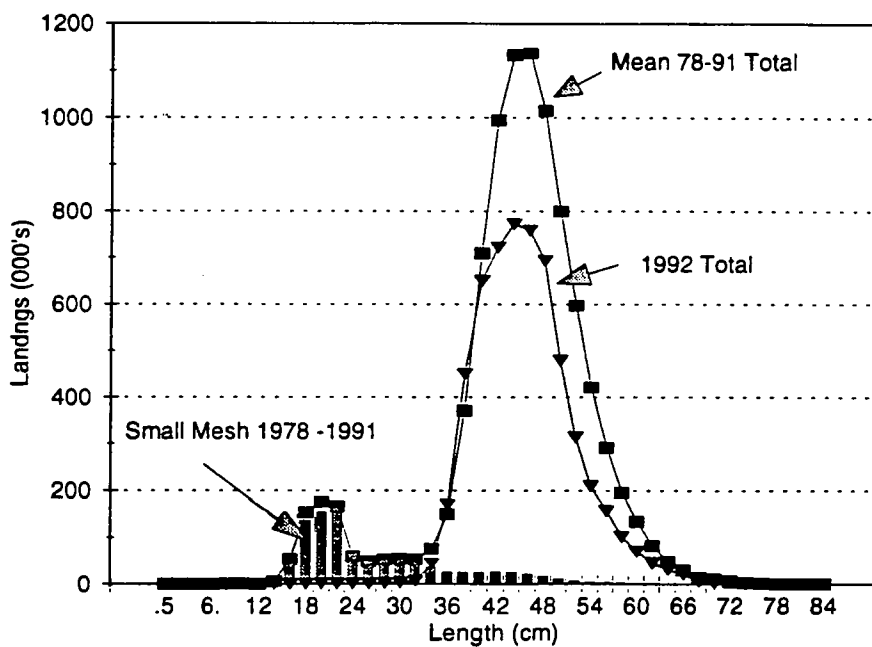
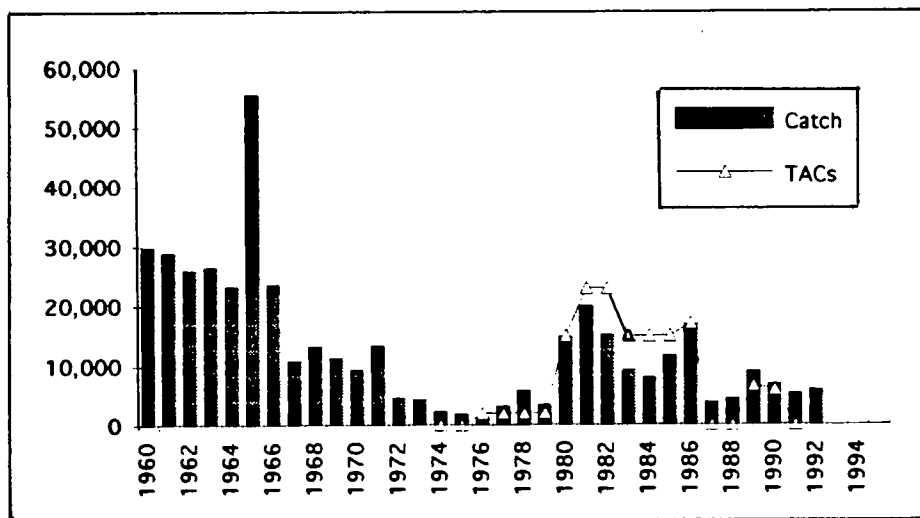

Fig. 1 .8b. 4TVW haddock. Catch at length (in 000's of fish) for the domestic and foreign small mesh fisheries on 4TVW haddock for the periods 1978-1991, and 1992.

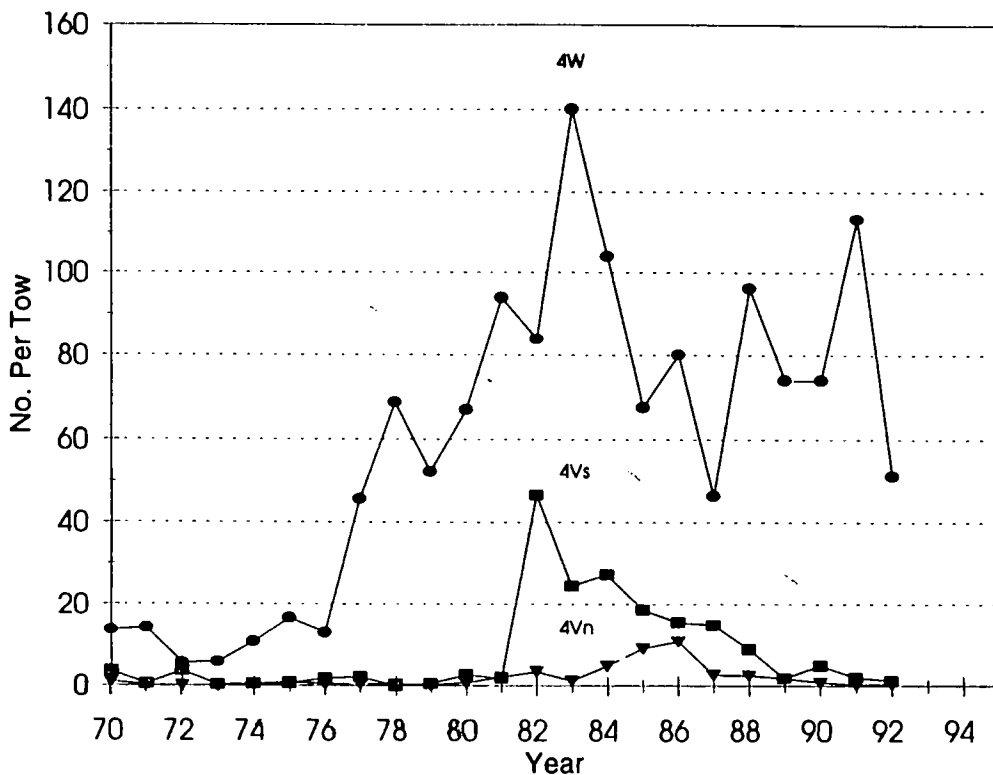

Fig. 1.8c. 4TVW haddock. Summer research vessel catch rates for 4TVW haddock 1970-1992.

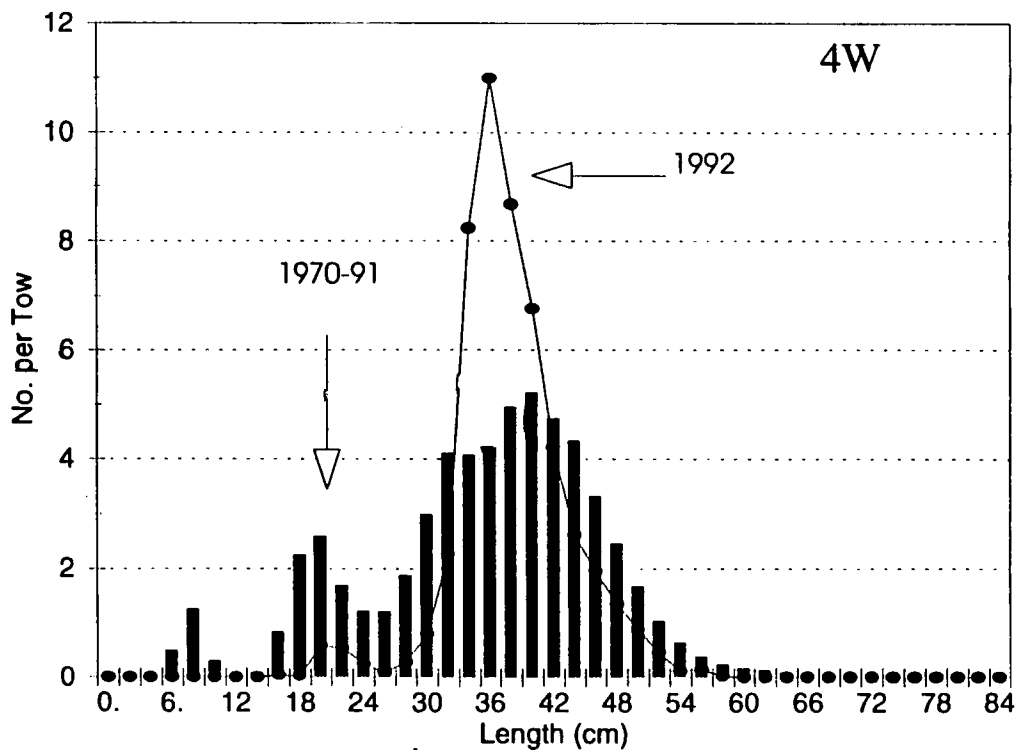

Fig. 1.8d. 4W haddock. Mean catch rates at length from summer surveys in Subdivision 4W for the years 1970-1991 (bars) and 1992 (line).

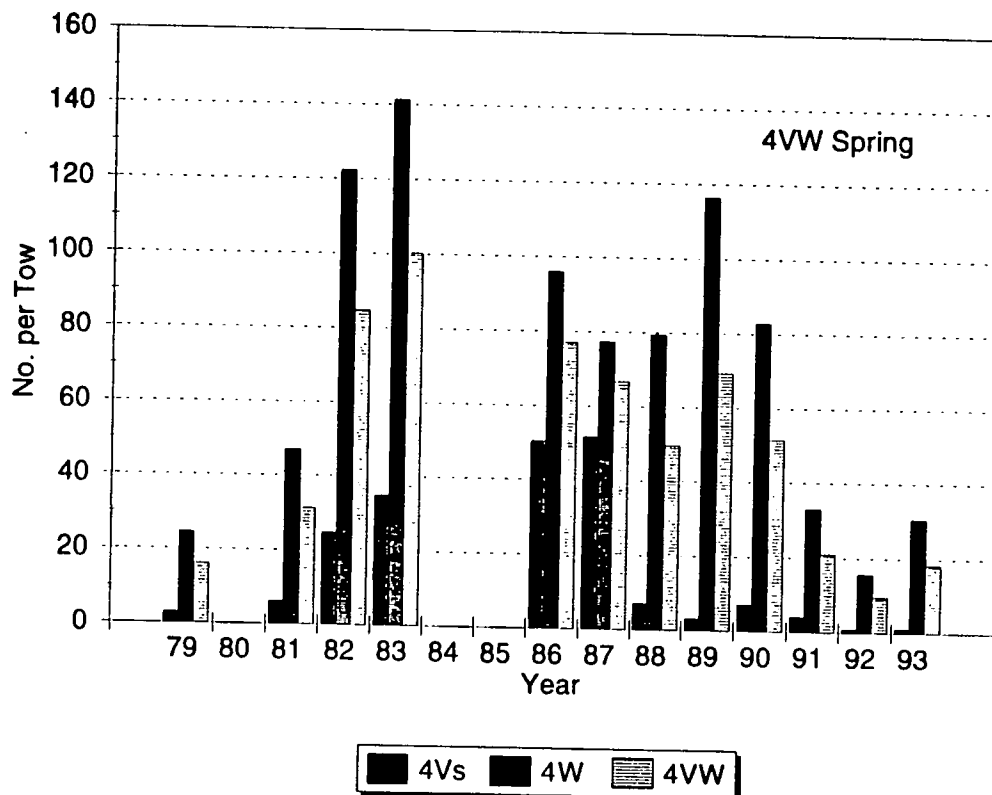

Fig. 1.8e. 4VW haddock. Catch rates from spring surveys (March) in 4VW for the period 1979 to 1993.

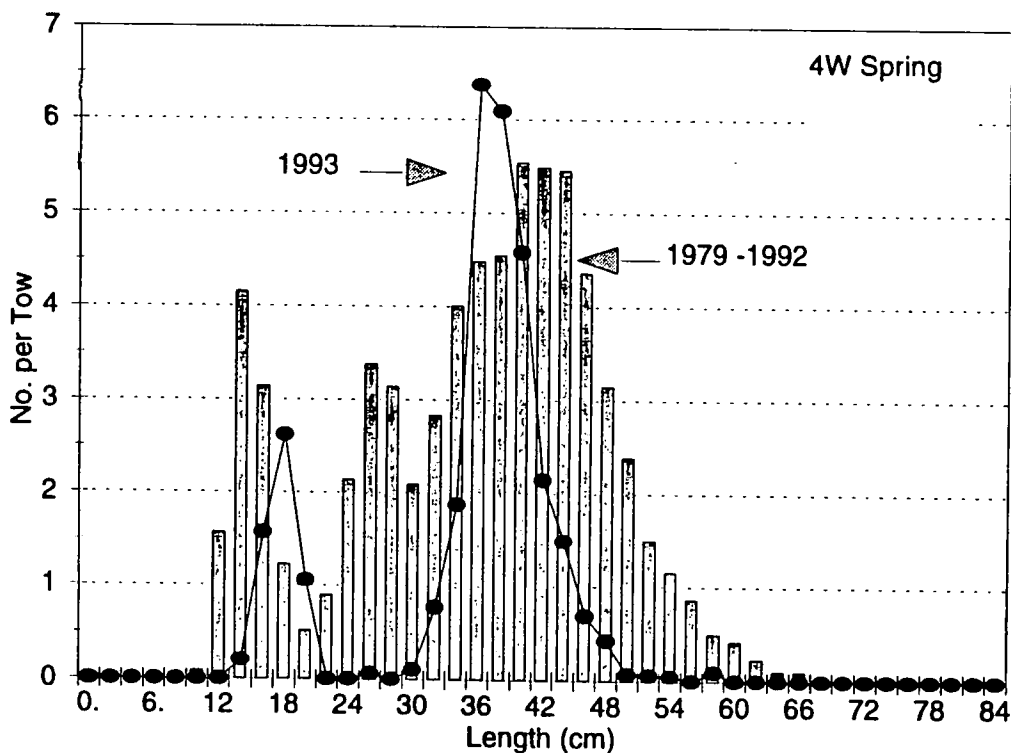

Fig. 1.8f. 4W haddock. Catch rates at length from spring surveys conducted in Division 4W for the period 1979-1992 (bars) and 1993 (lines).

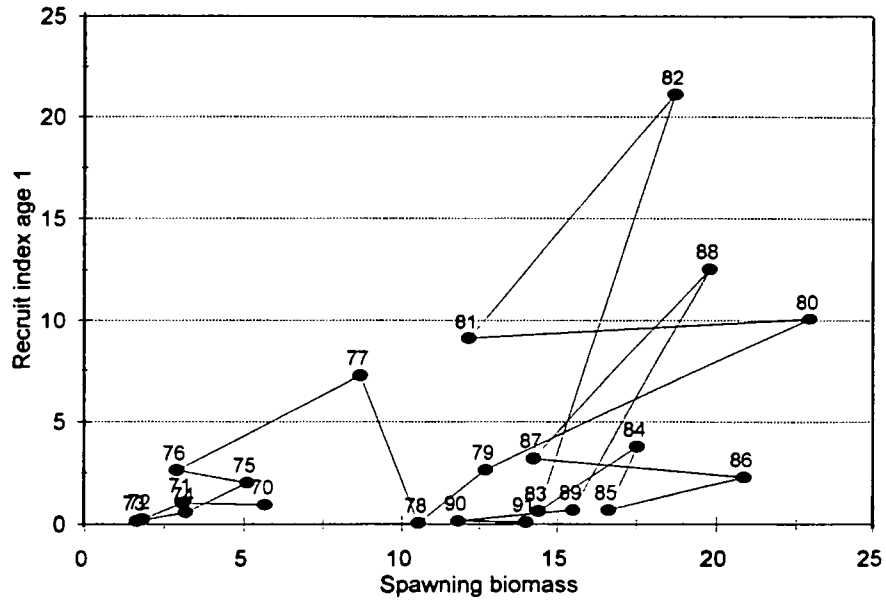

Fig. 1.8g. 4TVW haddock. Relationship between recruitment and spawning stock biomass.

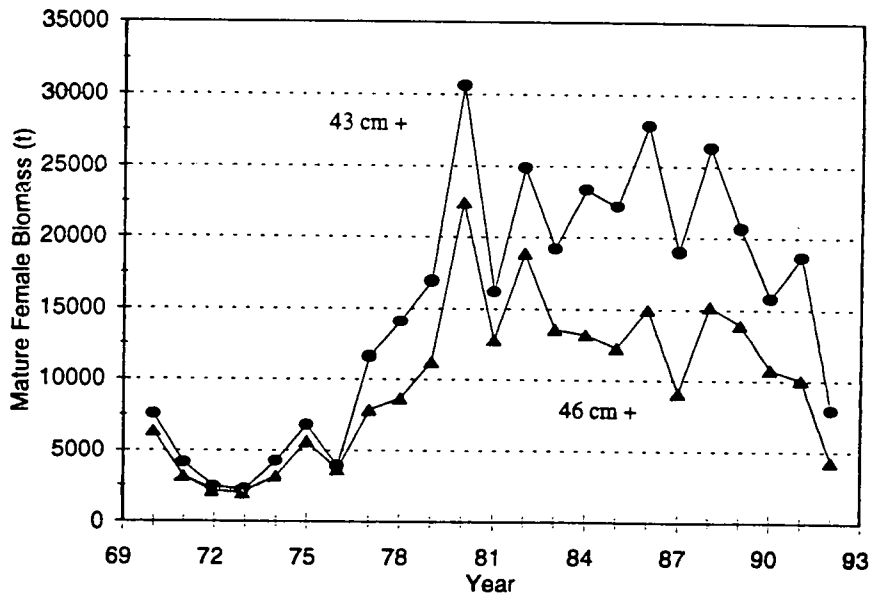

Fig. 1.8h. Summer survey estimates of mature female haddock biomass in 4VW from 1970-1992 assuming knife-edged maturation at either 43 cm or 46 cm.

Fig. 10.9a. Total catches (t) and TACs (t).

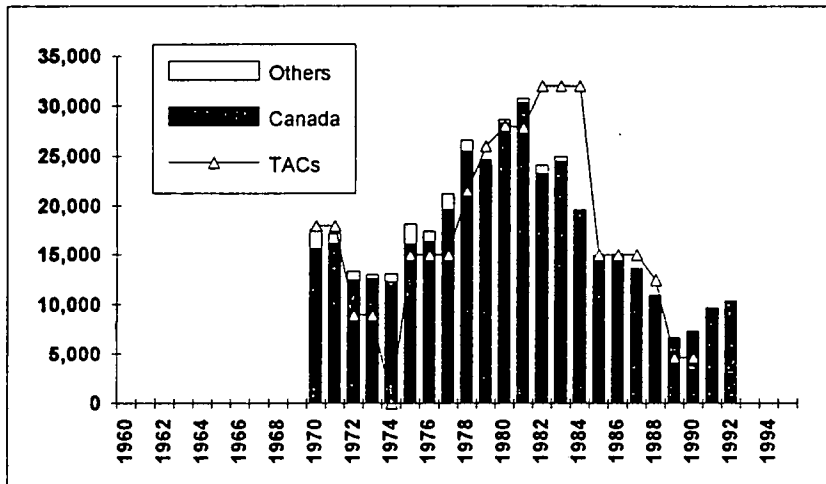

Fig. 10.9b. Fixed and Mobile Canadian Catches (t).

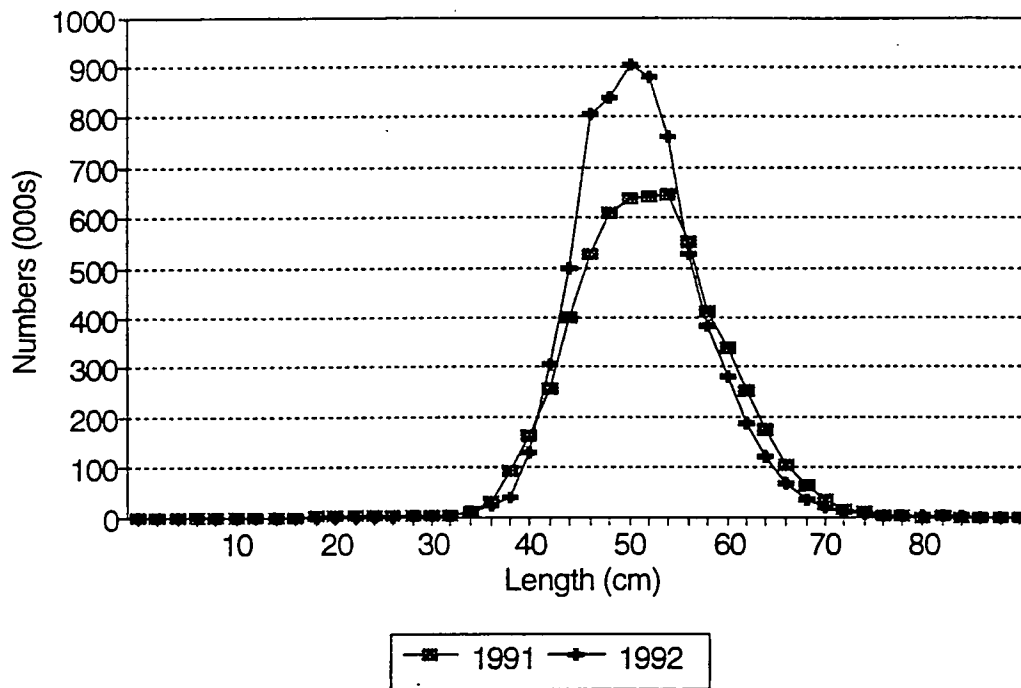
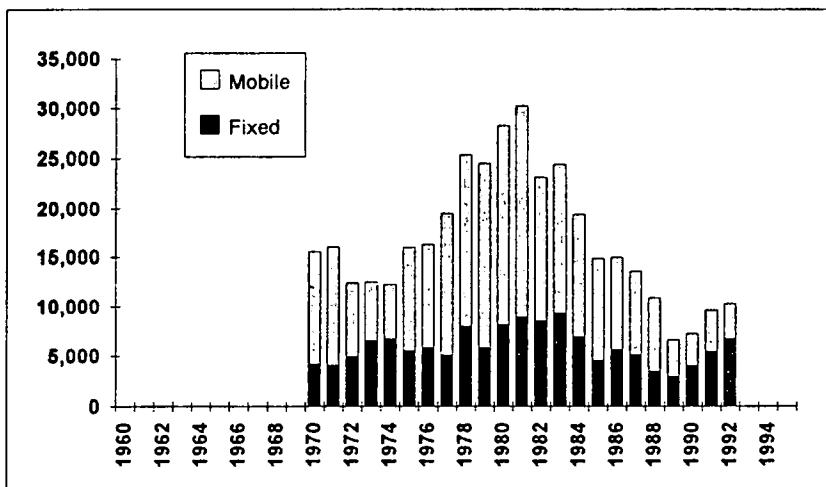

Fig. 10.9c. 4X haddock. Catch at length in 1991 and 1992.

Haddock in 4X

Abundance Indices

Fig. 1.9d. CPUE.

t/1000 hooks

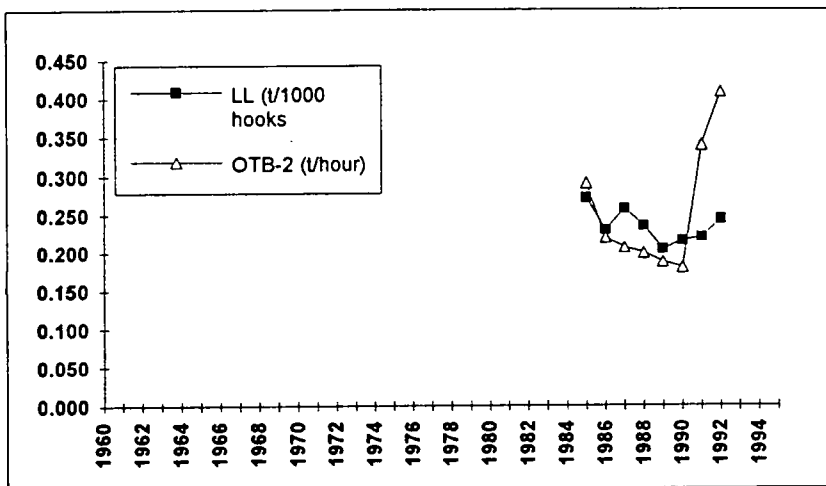

Haddock in 4X

Abundance Indices

Fig. 1.9e.

RV (kg/tow)

<43 cm

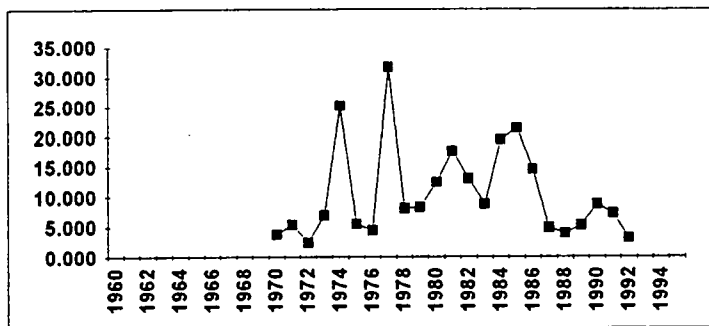

>43 cm

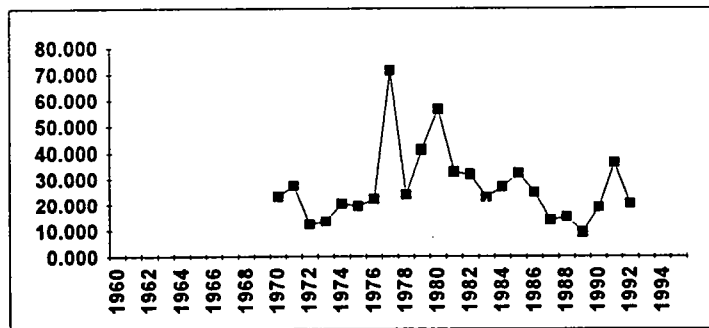

Total

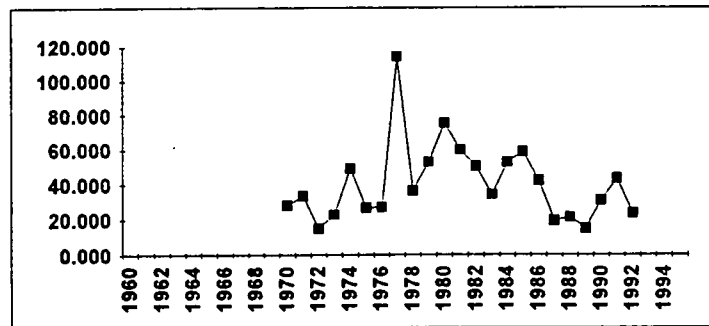



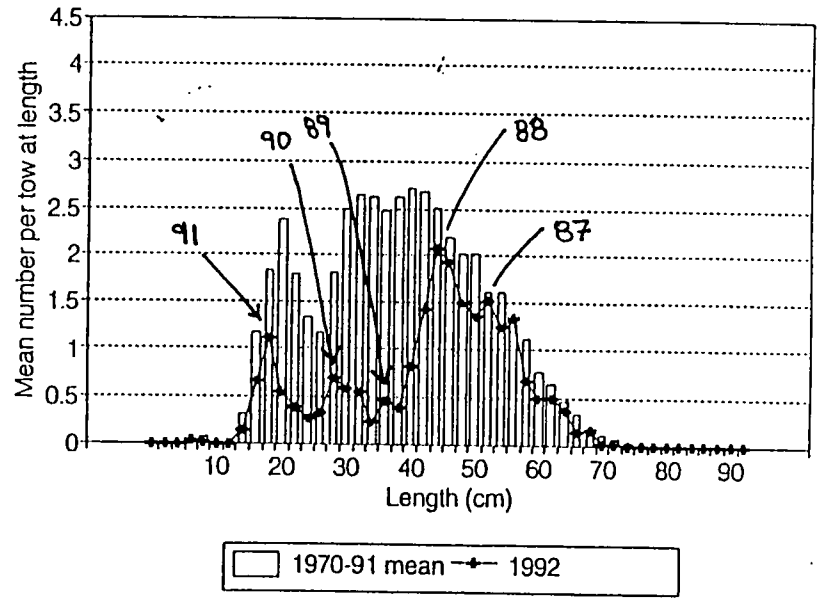
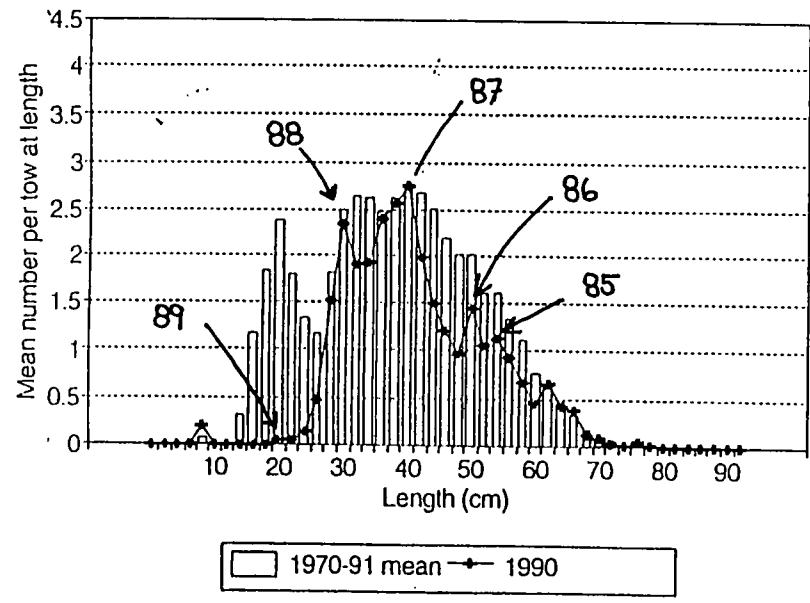
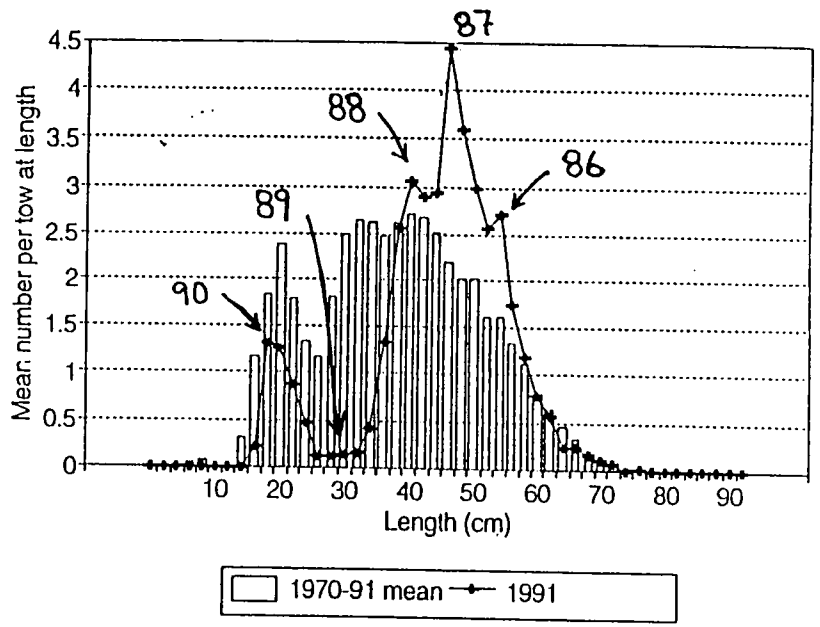
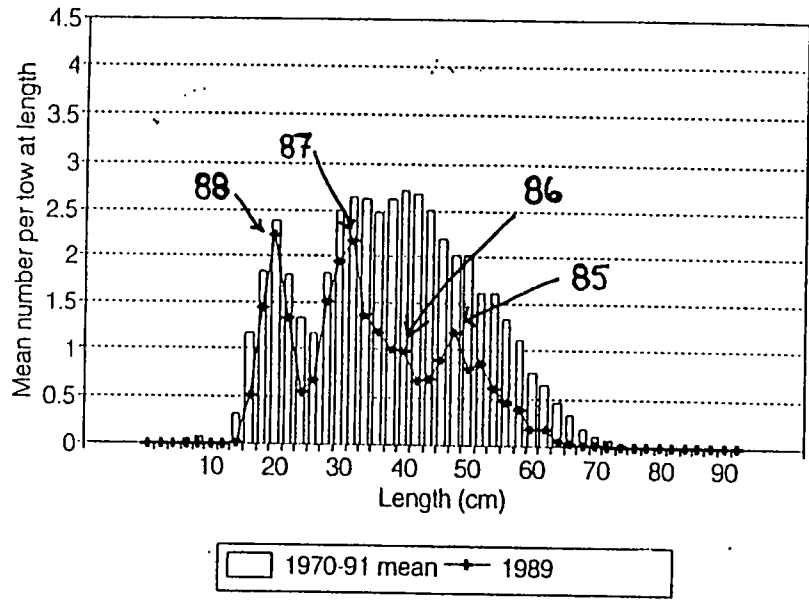

Fig. 1. 4X haddock. Research vessel catch at length for 1989, 1990, 1991 and 1992 vs. the mean catch at length for 1970-1991.

Haddock in 4X

Abundance Indices

Fig. 1.9g. RV (recruitment index).

1+2

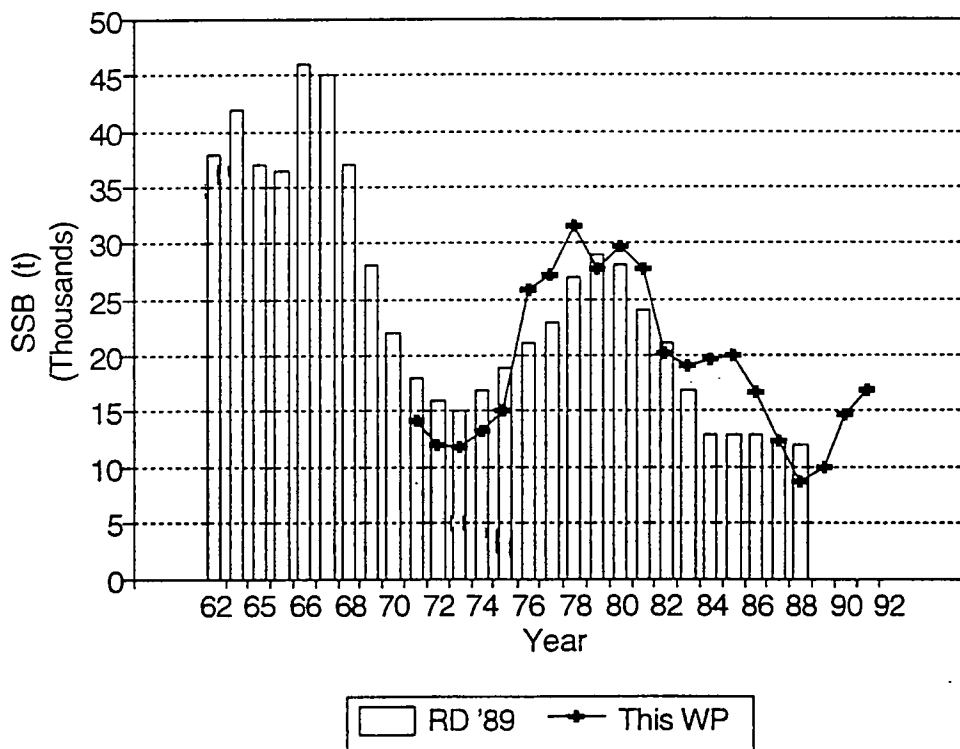
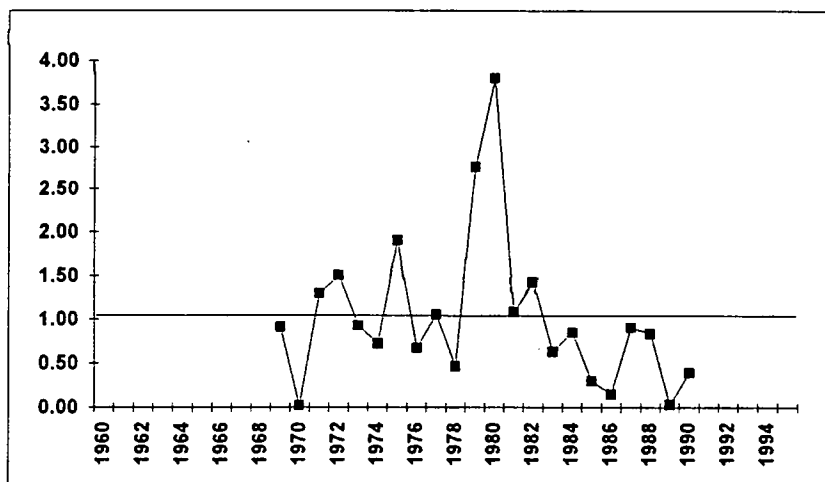

Fig. 1.9h. 4X haddock. Trends in spawning stock biomass for 1962-88 (from O'Boyle et al 1989) and 1970-92 spawning stock biomass (3 year mean) calculated from research vessel mean numbers at length.

Haddock in 5Zj,m

Fig. 1.10a. Total catches (t) and TACs (t)

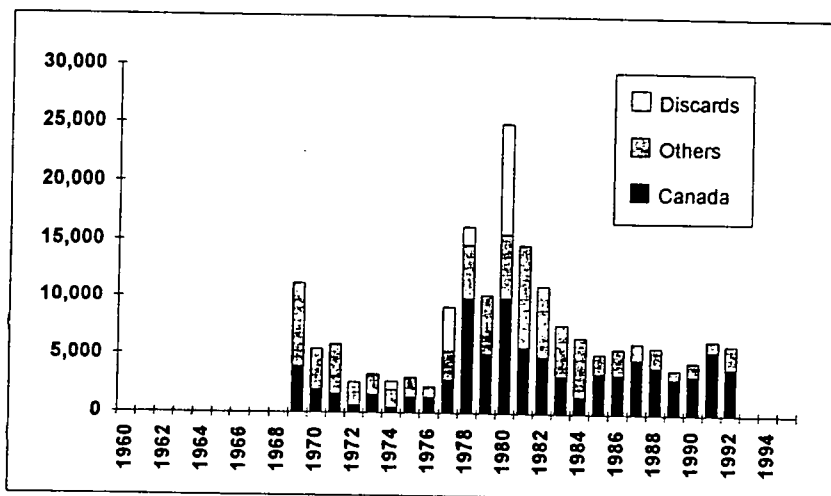
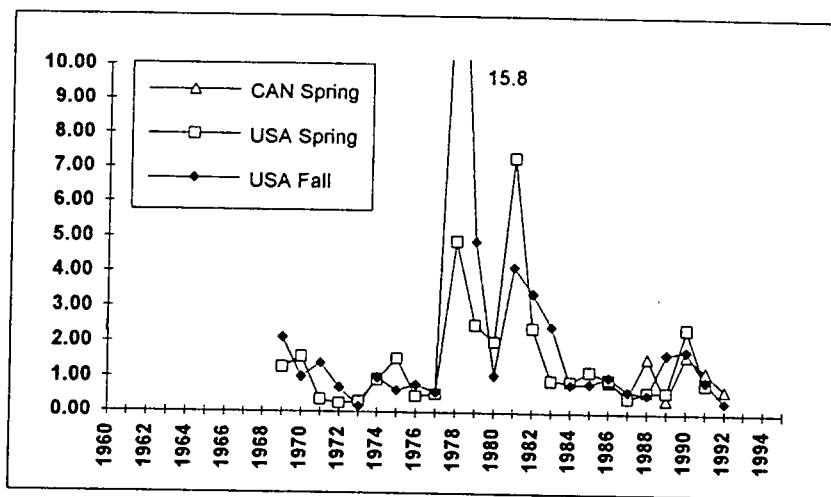
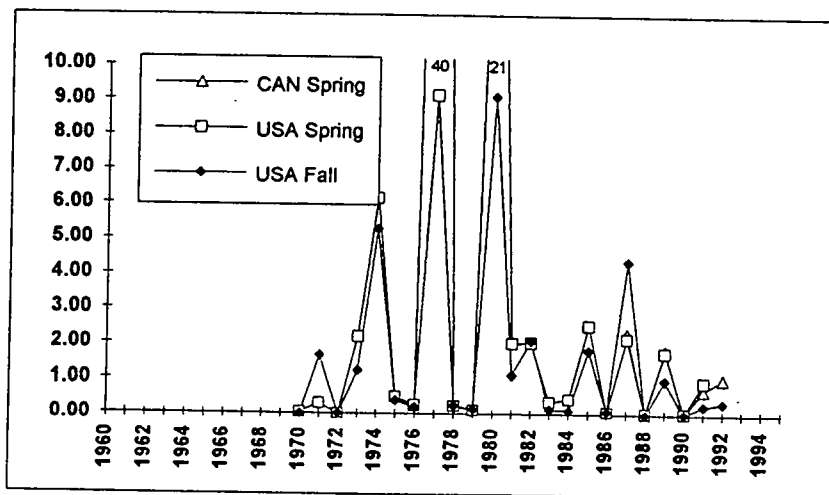

Fig. 1.10b. Abundance Indices Haddock in 5Zj,m  
RV (#) Ages 3-8



RV (#) Ages 1-2



Haddock in 6Zj,m

Abundance Indices

Fig. 1 .10c CPUE and Effort

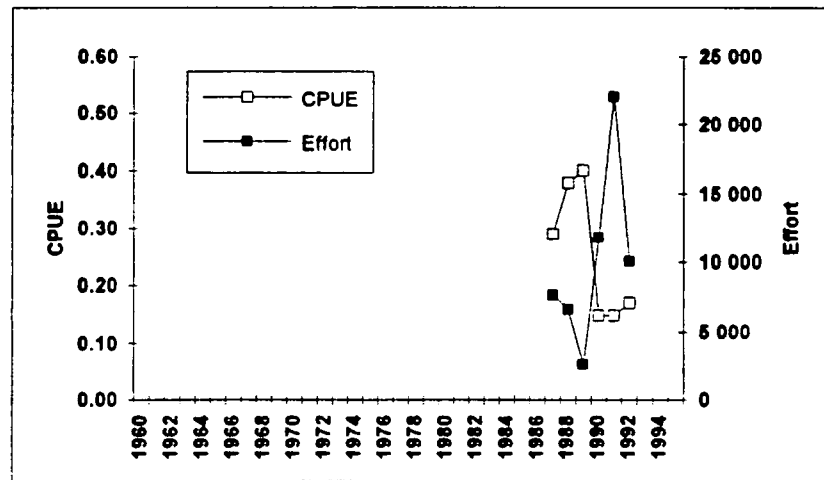

Haddock in 5Zj,m

Fig. 1.10d. Biomass 3+ ('000t)

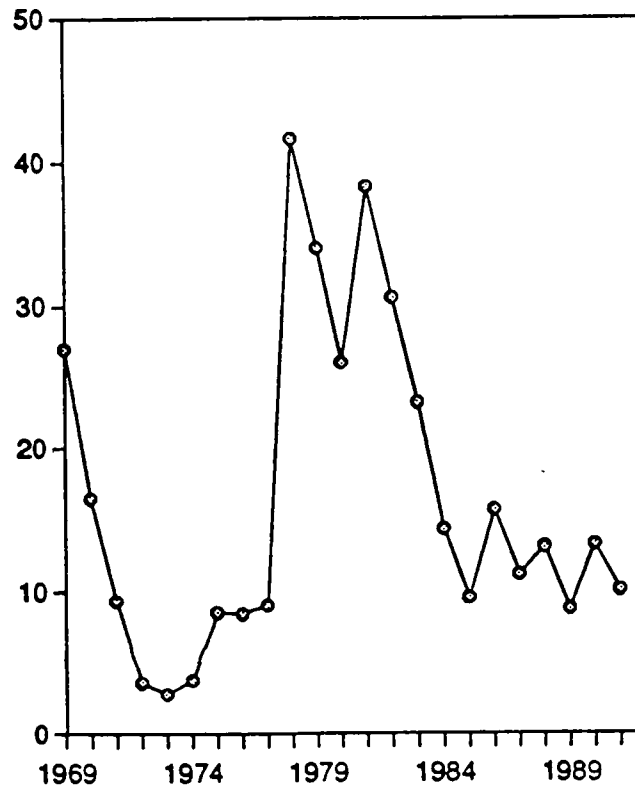

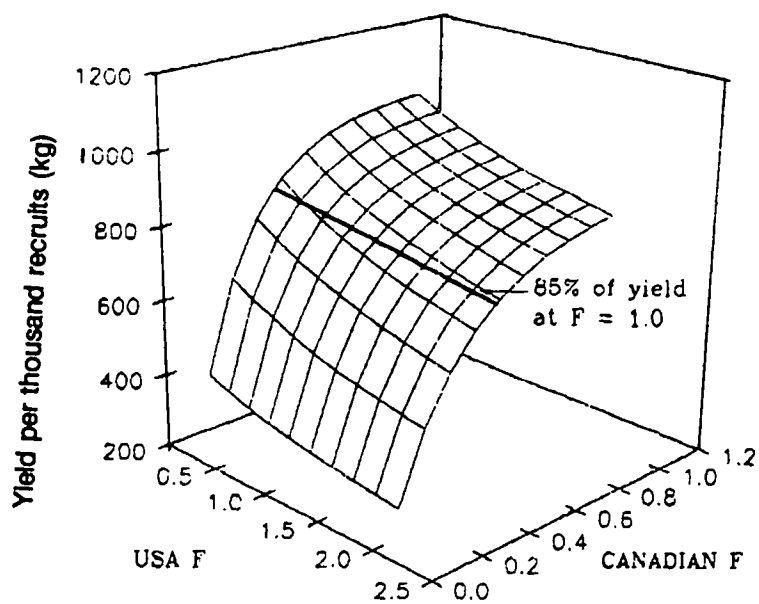
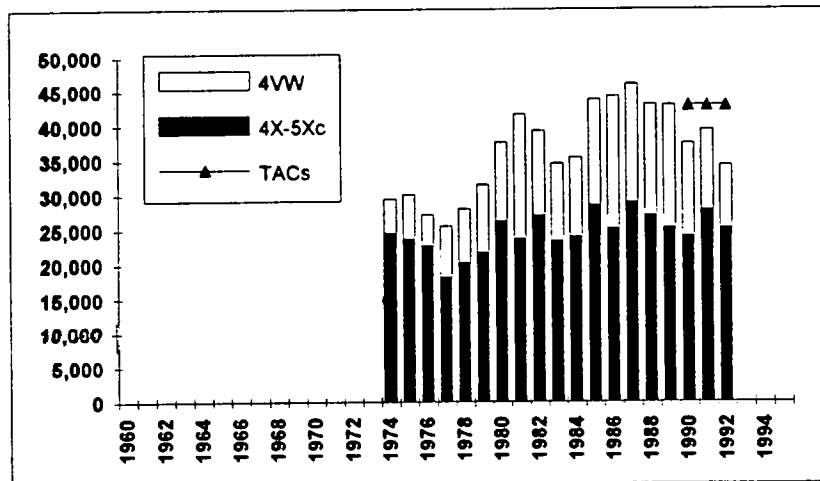

Fig. 1.10e. Yield to the Canadian fishery per thousand recruits.  
Exploitation expressed as instantaneous fishing mortality rate  
relative to population abundance in each respective territory.

Pollock in 4VWX+5

Fig. 1.11a. Total catches (t) and TACs (t)



Pollock in 4VWX+5

Abundance Indices

Fig. 1.11b.

TC-2 in 4X (ZIF)

All ages

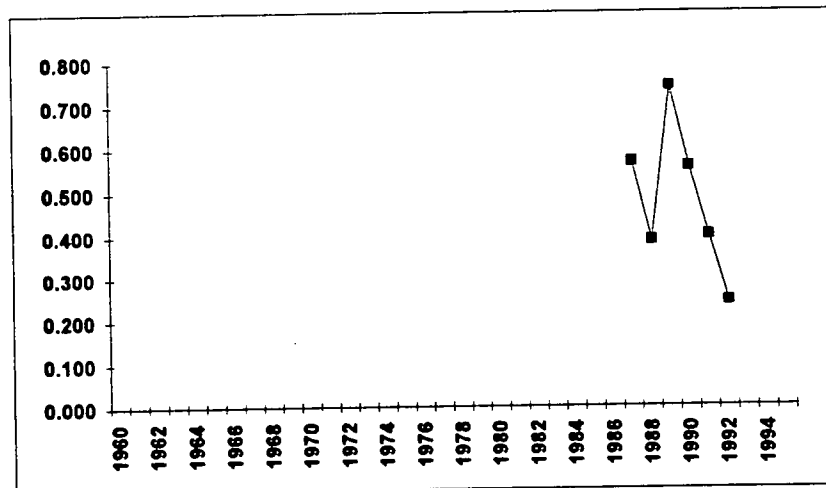
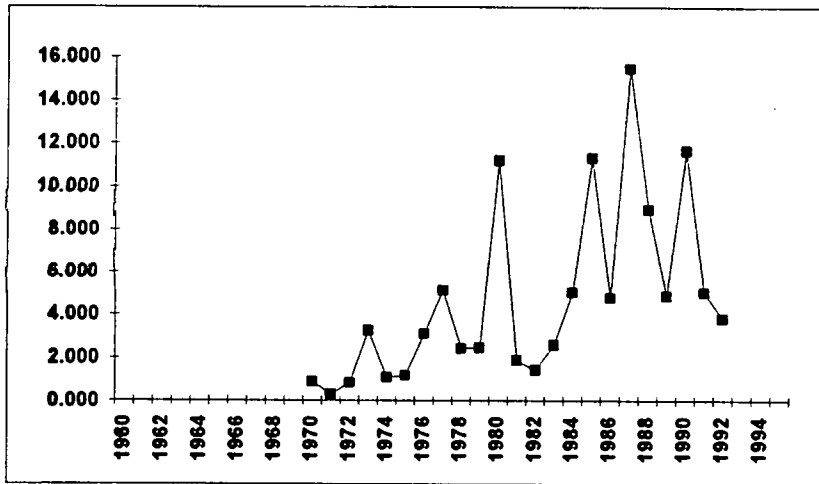

Fig. 1.11c.

RV (#/tow) - July

4-10



Pollock in 4VWX+5

ADAPT

Fig. 1.11d.

Annual fishing mortality.

7-9

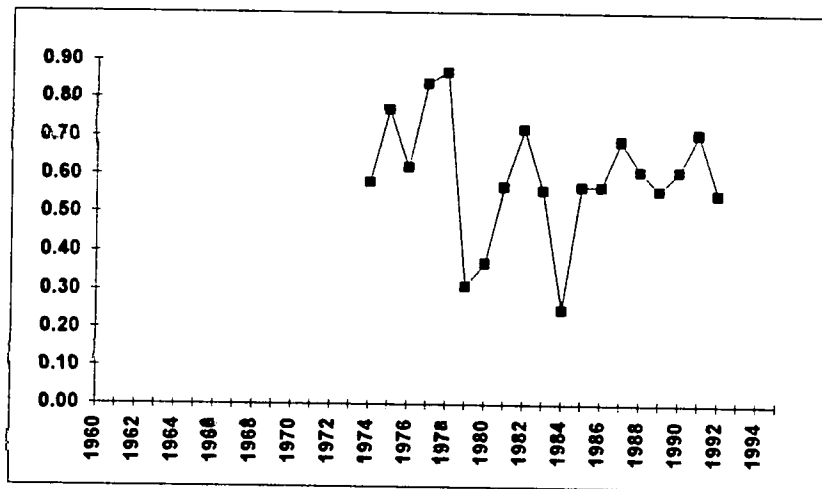
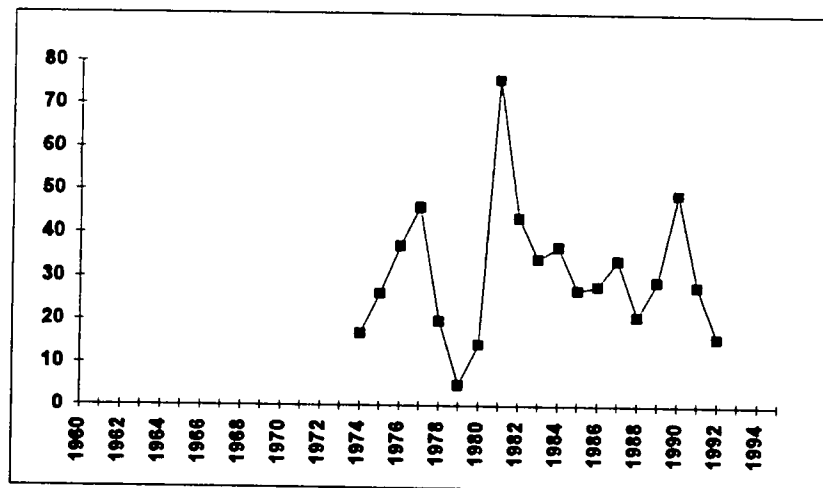

Fig. 1.11e.

Recruitment (million)

Age 2



Pollock in 4VWX+5

ADAPT

Fig. 1 .11f. Total Biomass (thousand t)

2+

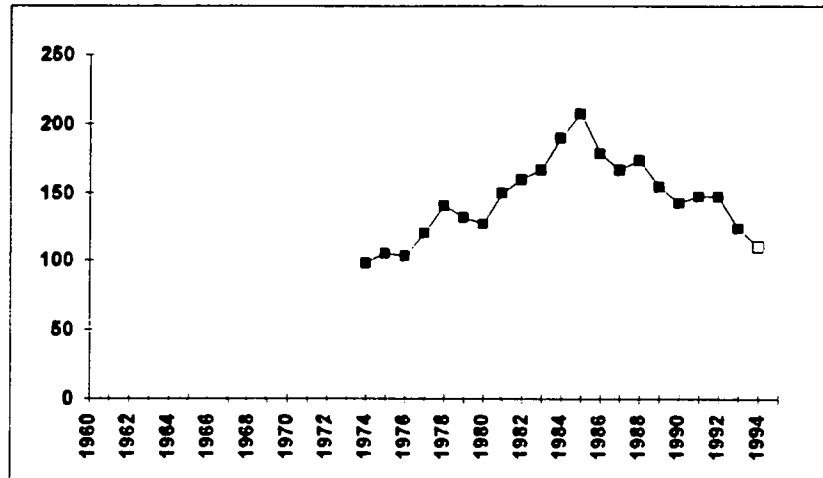

Fig. 1 .11g. Spawning Biomass (thousand t)

4+

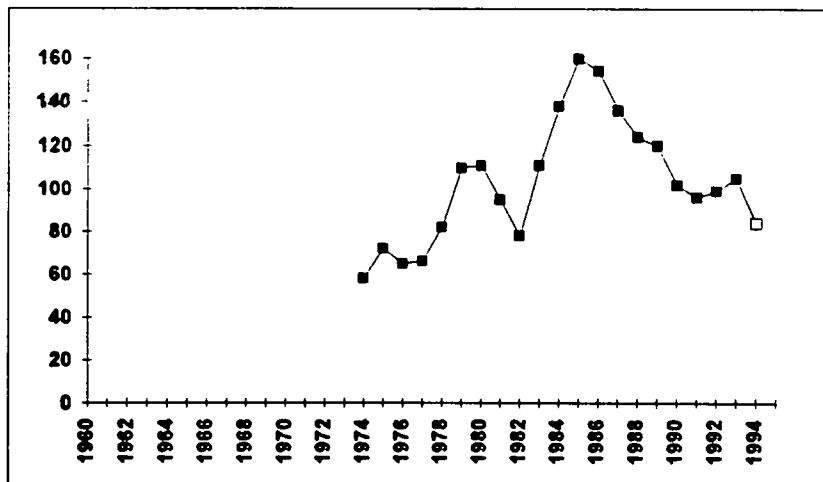
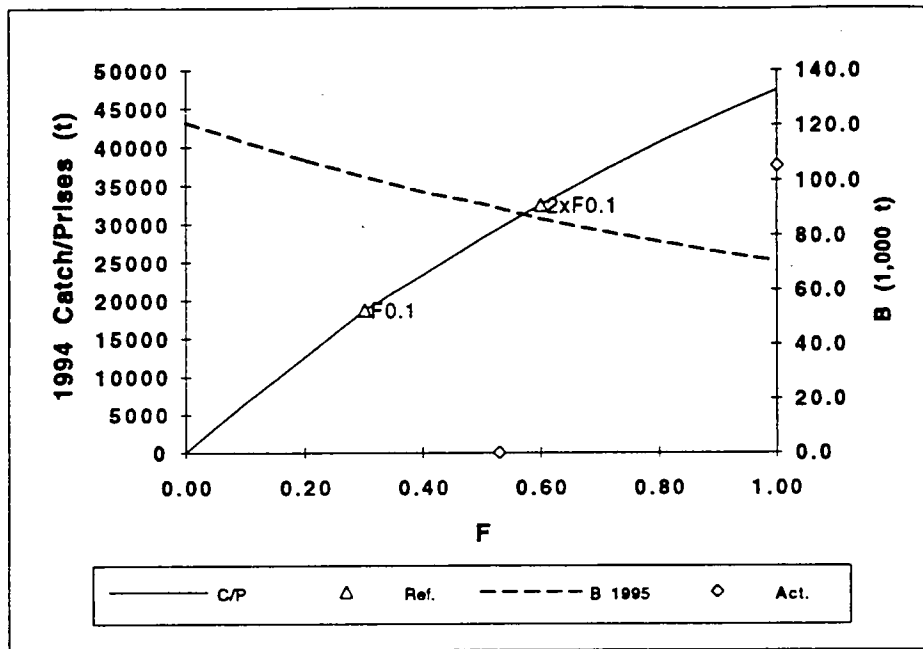



Fig. 1 .11h.

Pollock in 4VWX+5Ze

Projections



C/P = Catch - Prises  
 Ref. = Reference - Référence  
 B 1995 = Adult biomass at beginning of 1995 - Biomasse adulte au début de 1995  
 Act. = Actual - Actuel

F1992= 0.53

Gulf Redfish

Fig. 1 .12a. Total catches (t) and TACs (t)

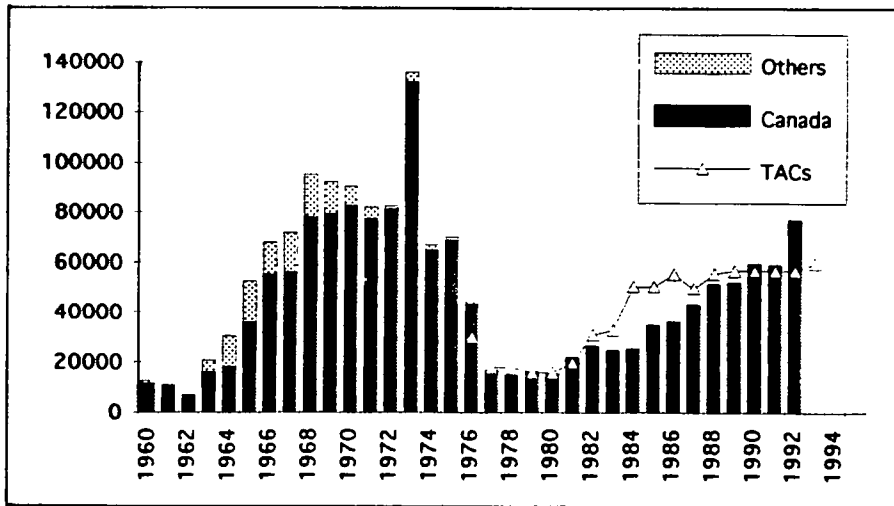

Note: TACs given for 1976-1992 are for the former management unit (4RST).

Fig. 1 .12b. CPUE (1/hr) OTB-OTM

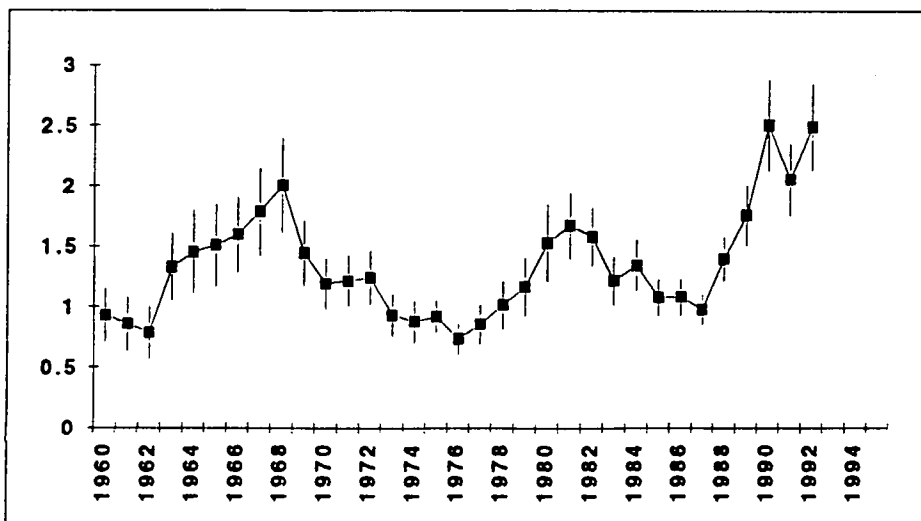

Fig. 1 .12c. CPUE (1/h) - OTB(May-Oct.)

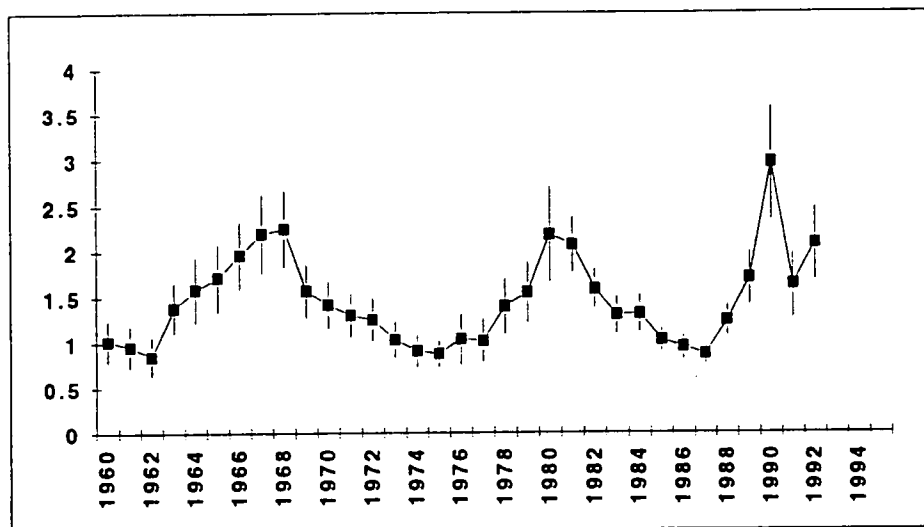
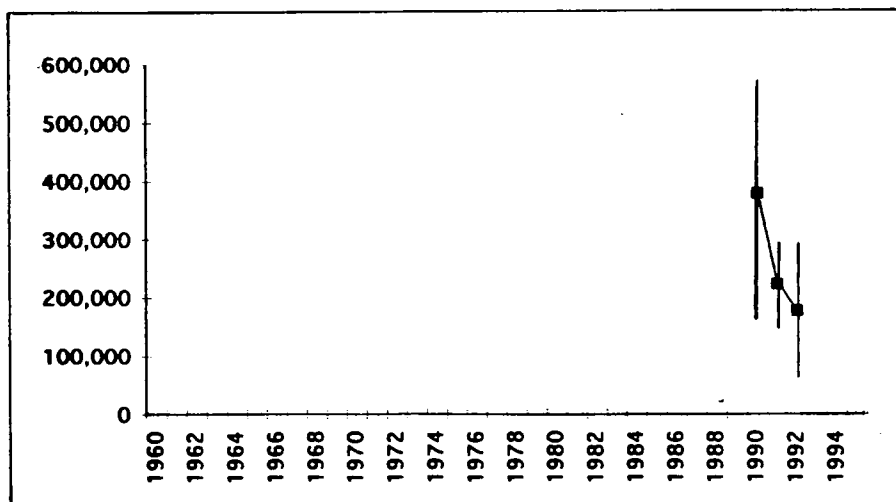

Fig. 1 .12d. Research vessel summer biomass (t).

All ages



Plaice in 2+3K

Fig. 1.13a. Total catches (t) and TACs (t)

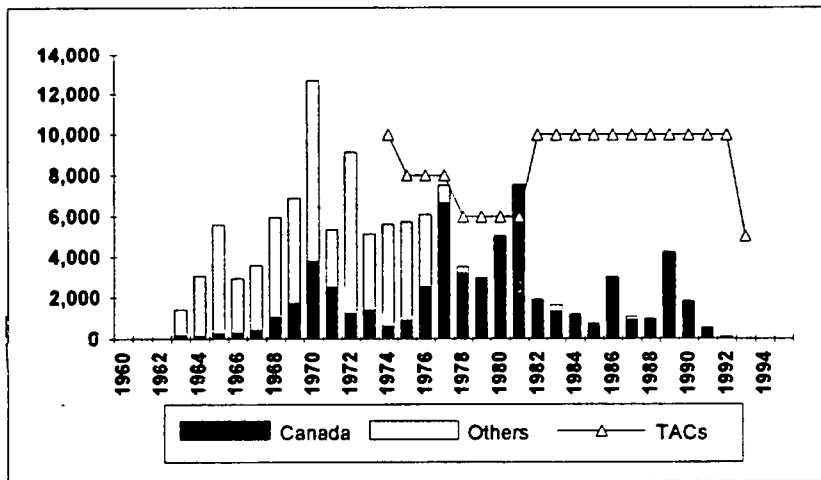
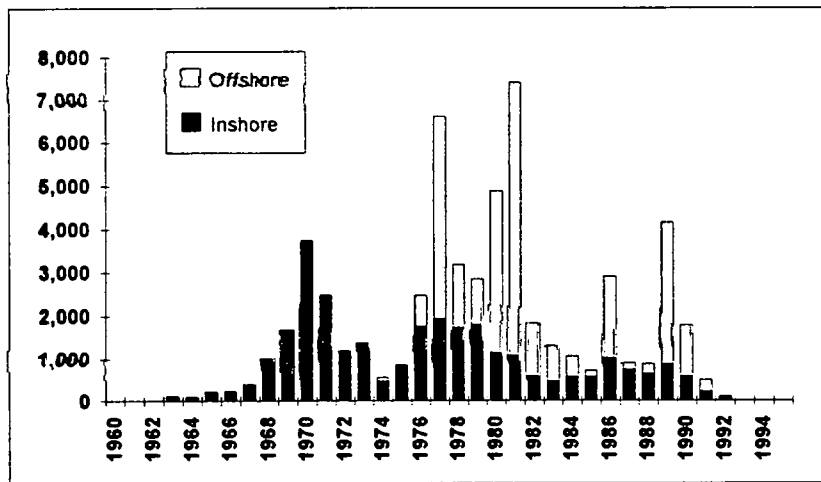

Fig. 1.13b. Inshore and Offshore Canadian Catches (t)



Plaice in 2+3K

Abundance Indices

Fig. 1.13c.

RV in 2J (#/tow)

1+

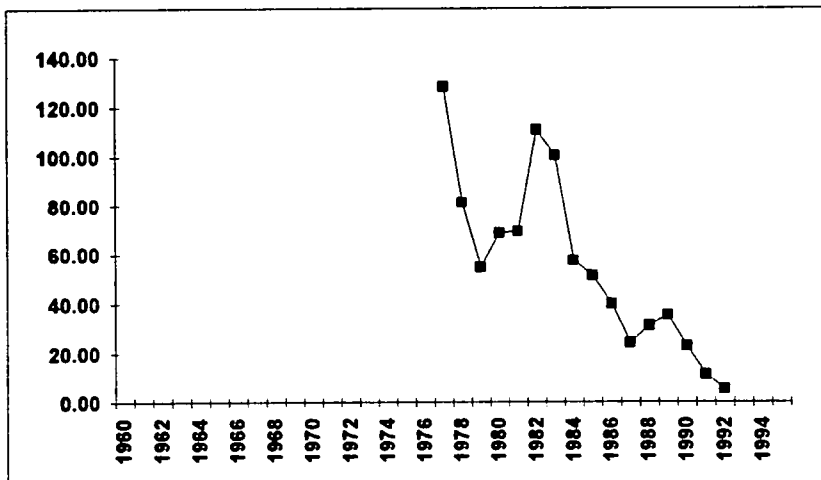
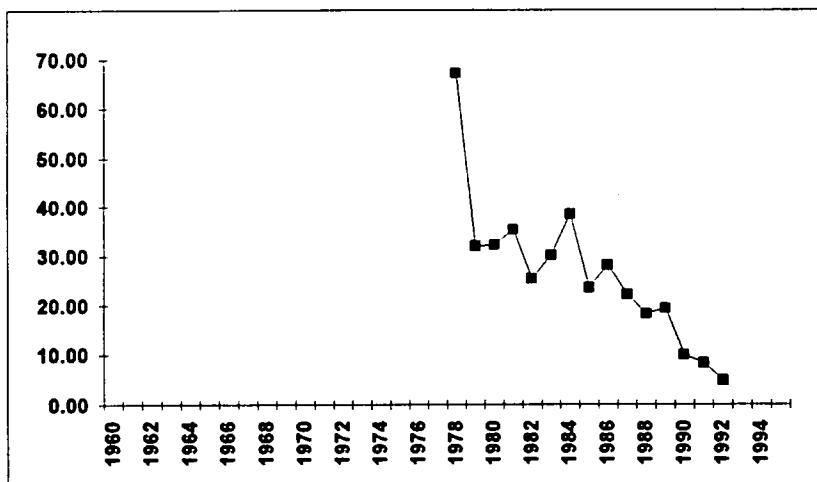

Fig. 1.13d.

RV in 3K (#/tow)

1+



American Plaice in 3Ps

Fig. 1.14a. Total catches (t) and TACs (t)

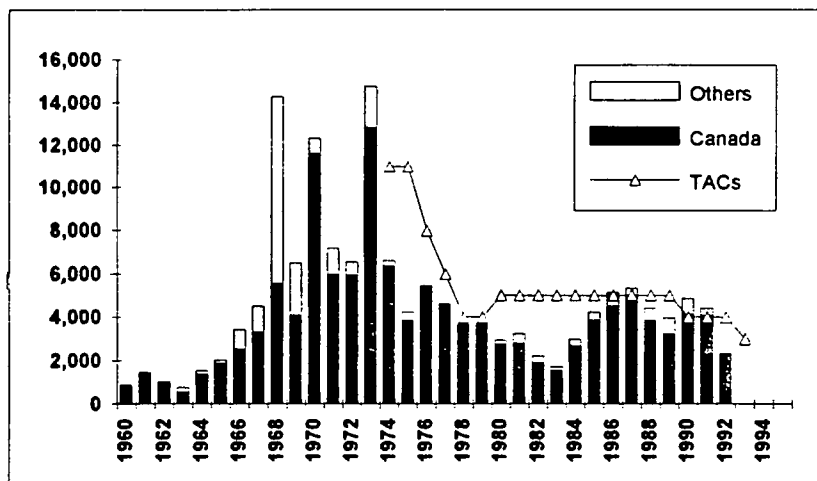
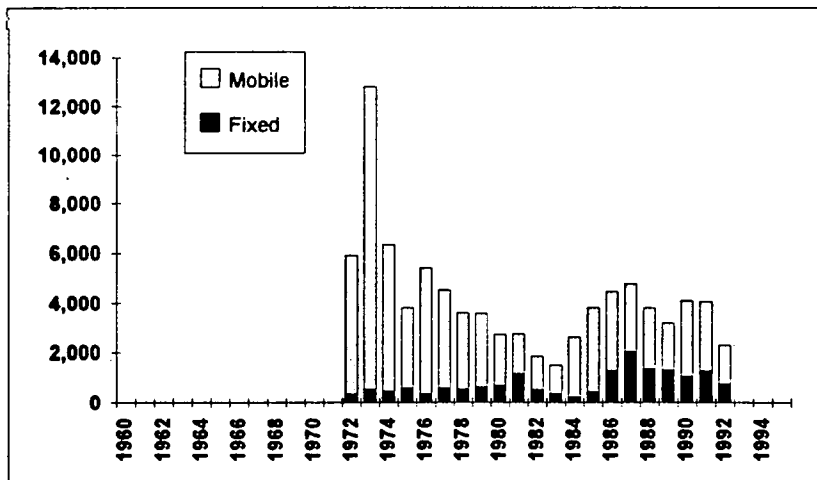

Fig. 1.14b. Fixed and Mobile Canadian Catches (t)



American Plaice in 3Ps

Abundance Indices

Fig. 1.14c.

Mean Weight (kg)

at age 10

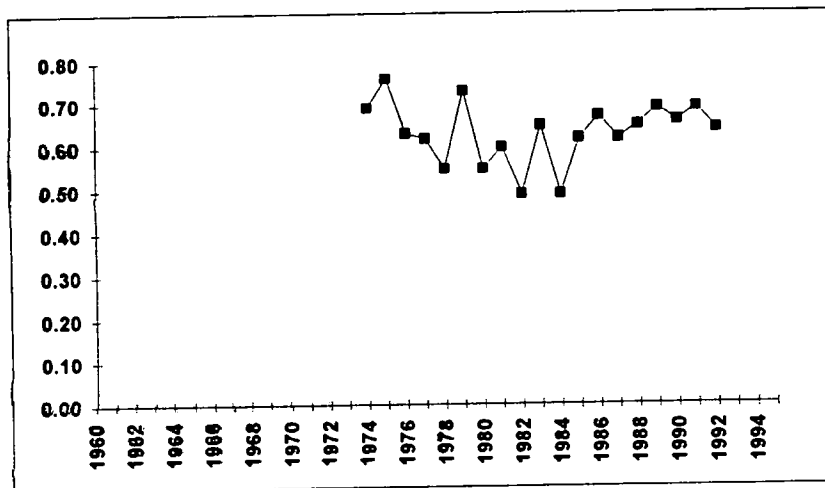
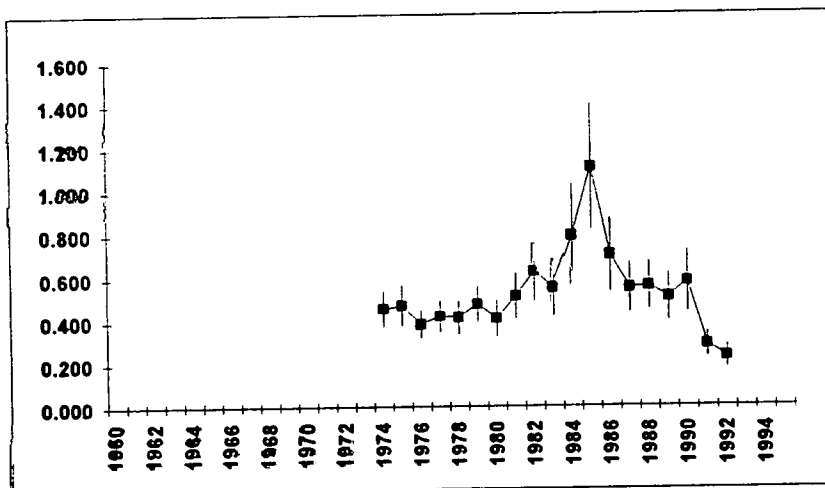

Fig. 1.14d.

CPUE (units)

All ages



American Plaice in 3Ps

Abundance Indices

Fig. 1.14e.

CAN RV (Mean # per tow)

1+

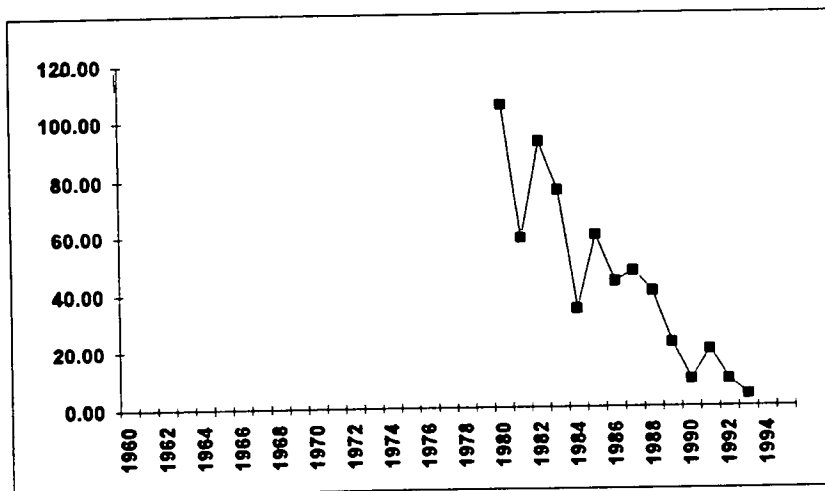
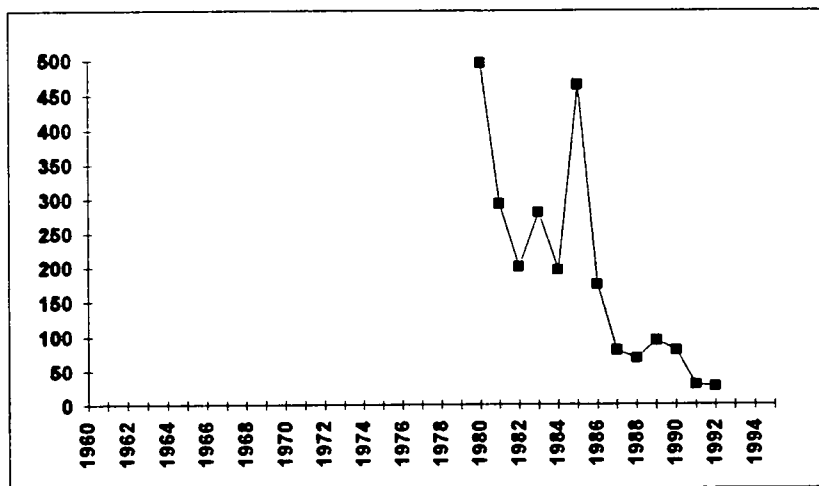

Fig. 1 .14f.

FRENCH RV (Mean # per tow)

1+



American Plaice in 4T

Fig. 1 .15a. Total catches (t) and TACs (t)

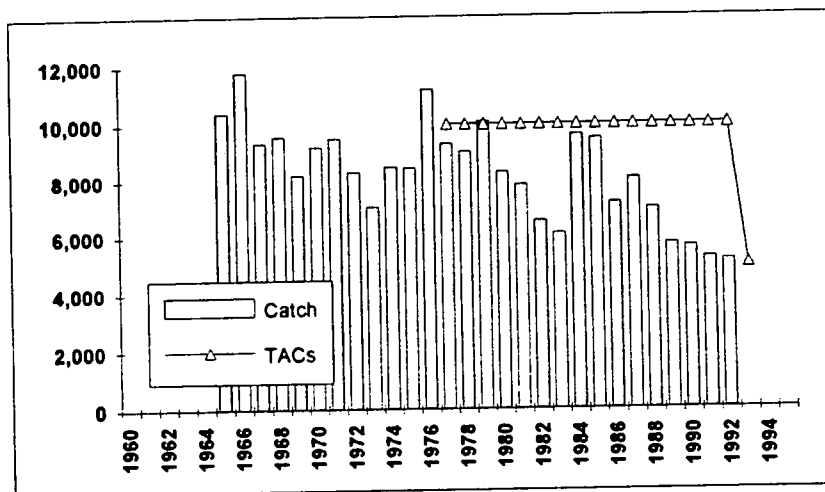

American Plaice in 4T

Abundance Indices

Fig. 1 .15b.

RV (#/tow) - Fall

1+

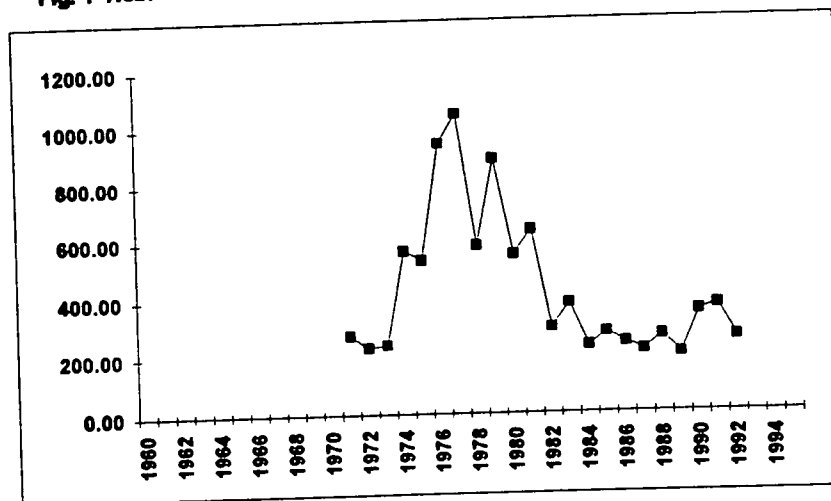

American Plaice in 4VW

Fig. 1.16a. Total catches (t) in 4VW

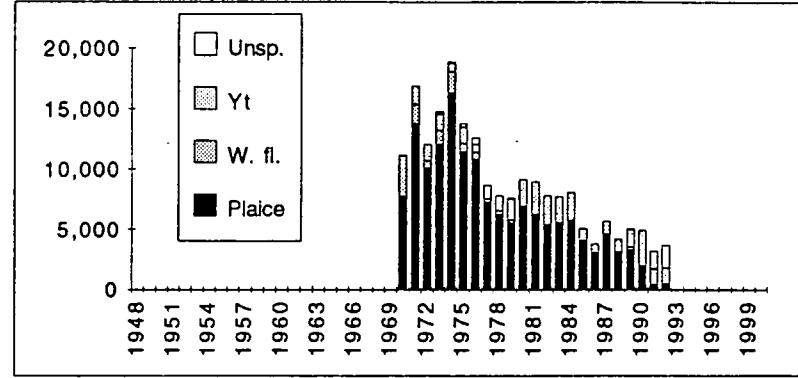

Fig. 1.16b Summer RV Mean # per tow All ages

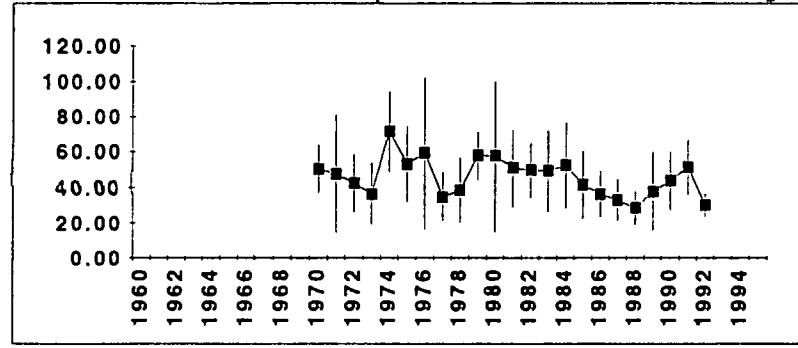
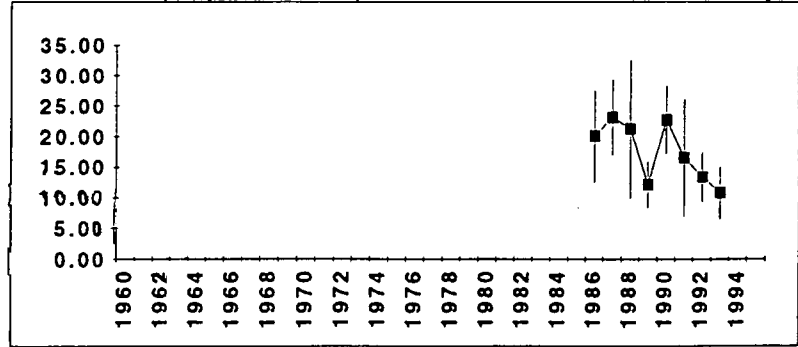

Fig. 1.16c Spring RV Mean # per tow All ages



American plaice in 4X

Fig. 1.17a. Total catches (t)

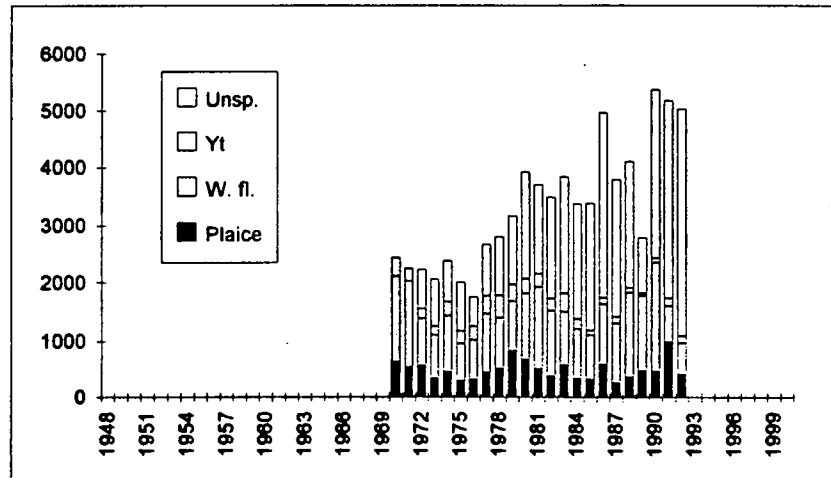
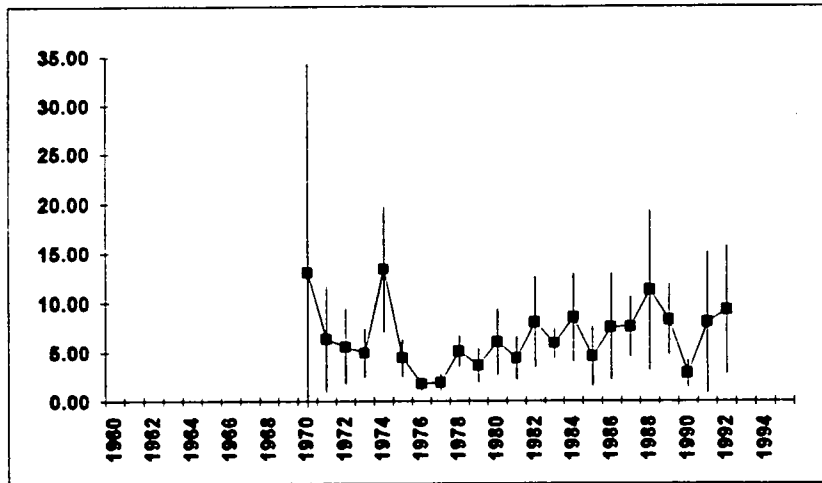

Fig. 1 .17b.

Summer RV Mean # per tow

All ages



Witch in 2J-3KL

Fig. 1 .18a. Total catches (t) and TACs (t).

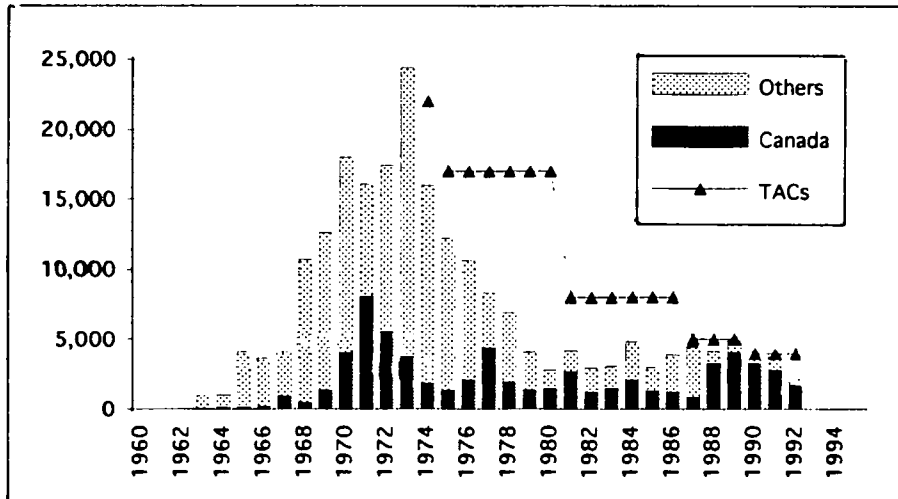
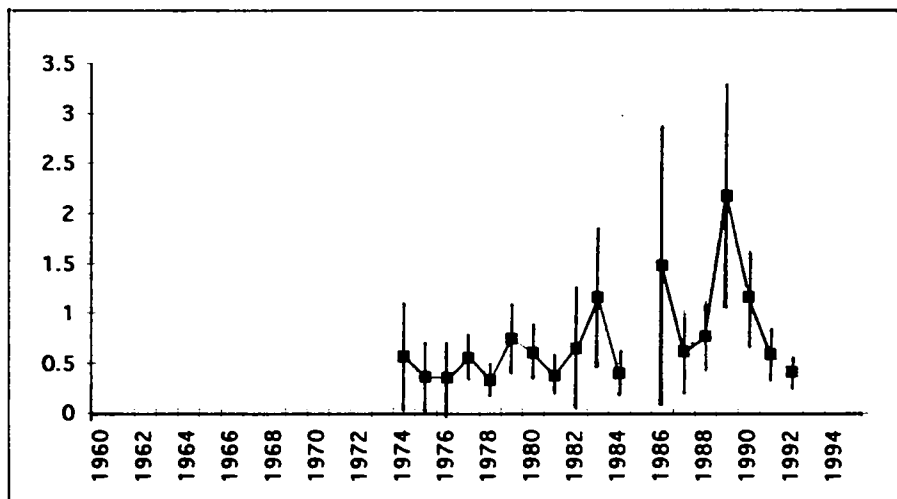

Fig. 1.18b.

CPUE (t/hour)

All ages





Witch in 2J-3KL

Abundance Indices

Fig. 1.18c.

RV Min. Biomass (t)

All ages

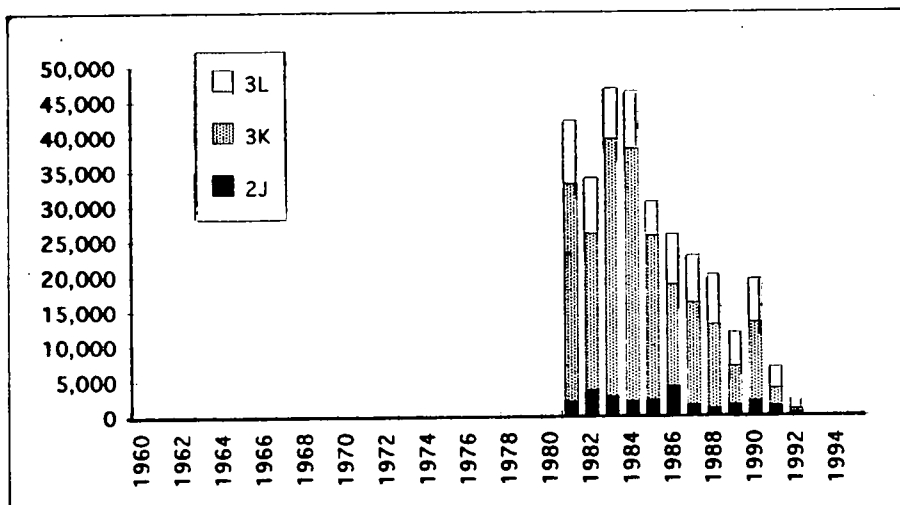

Witch in 3Ps

Fig. 1.19a. Total catches (t) and TACs (t).

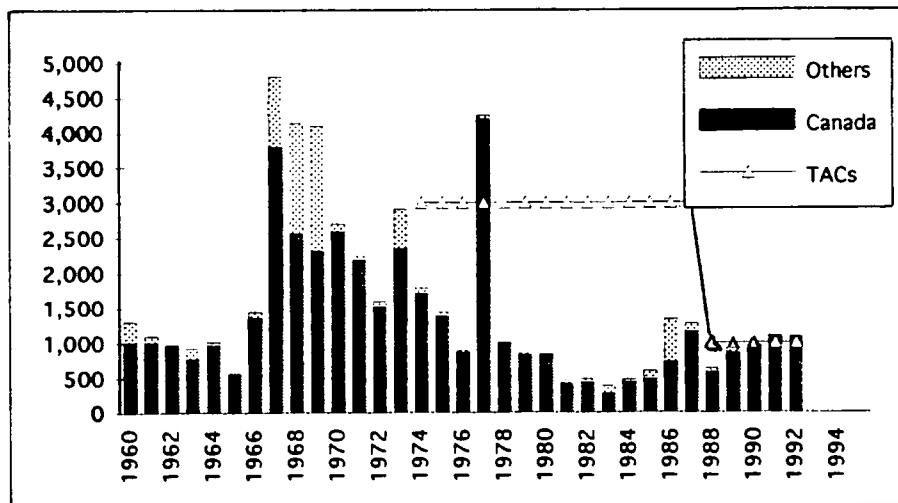
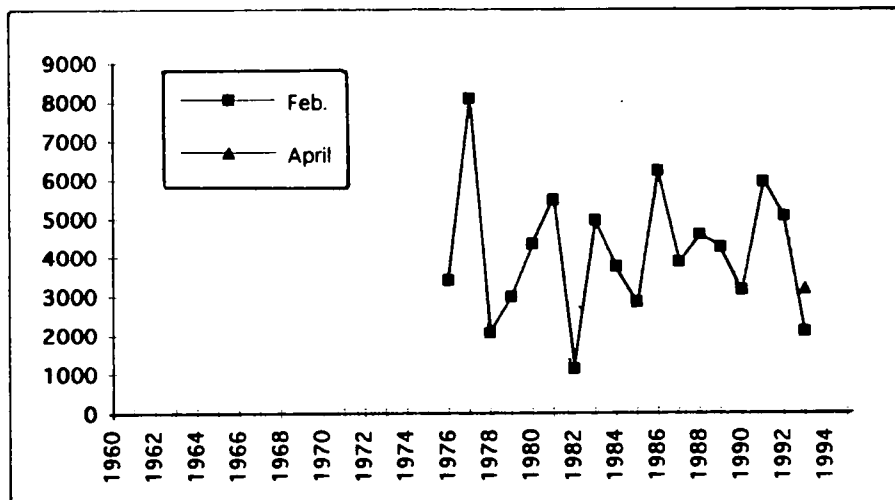

Fig. 1.19b. RV Min. Biomass (t).

All ages



Witch in 4RS

Fig. 1.20a. Total catches (t) and TACs (t)

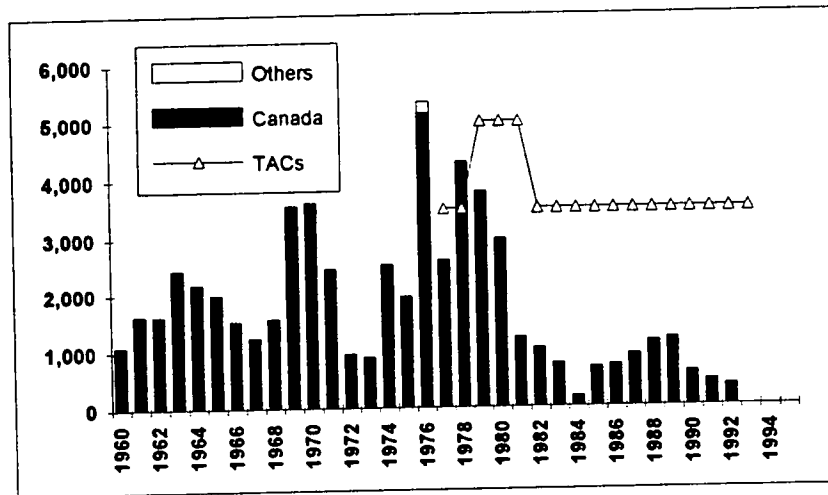

Witch in 4RS

Abundance Indices

Fig. 1.20b.

RV (#/tow) in 4R

All ages

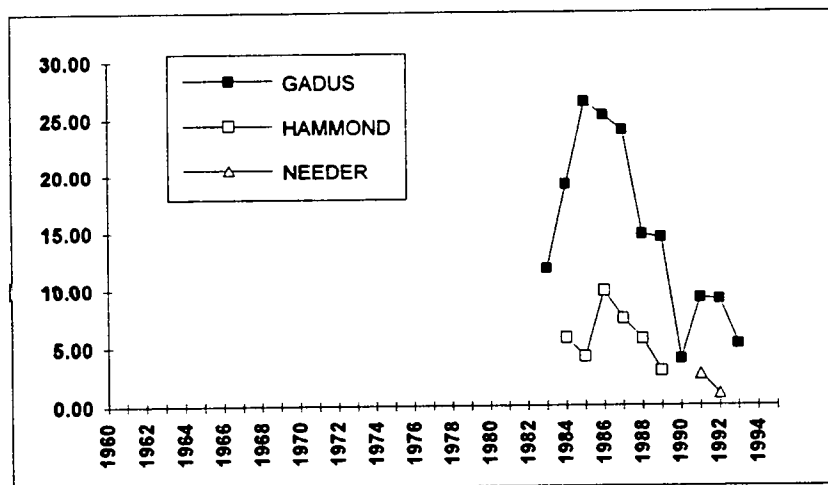

Fig. 1.20c.

RV (#/tow) in 4S

All ages

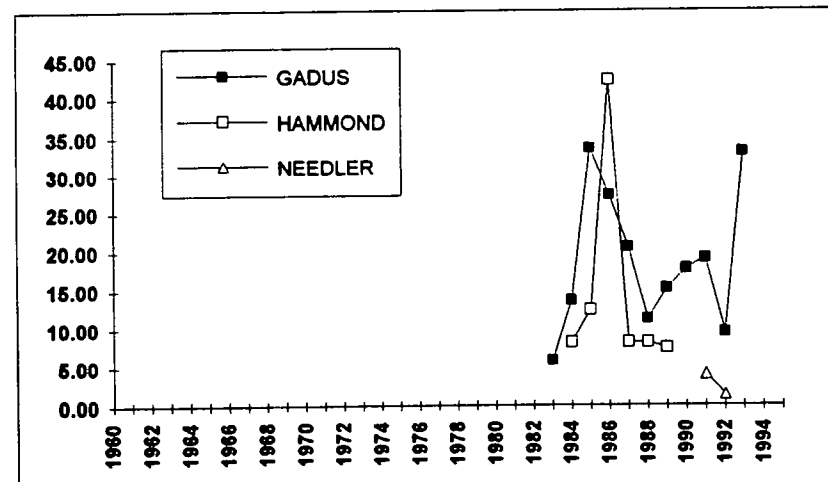

Fig. 1. .21a. Total catches (t) in 4VW.

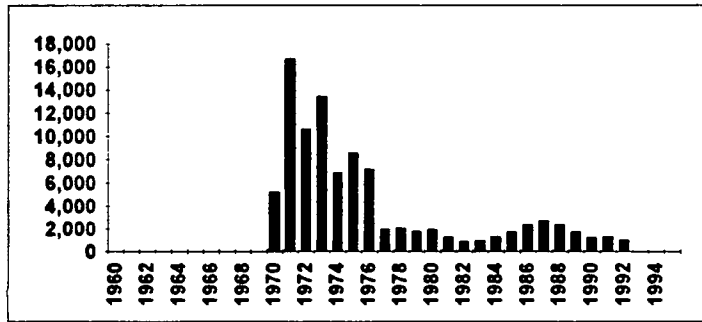

Fig. 1. .21b. Summer RV Mean # per tow All ages

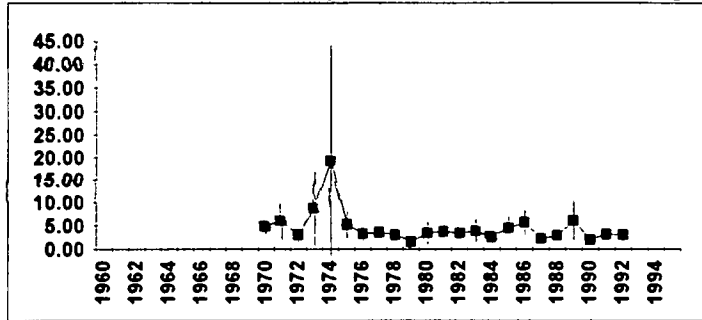
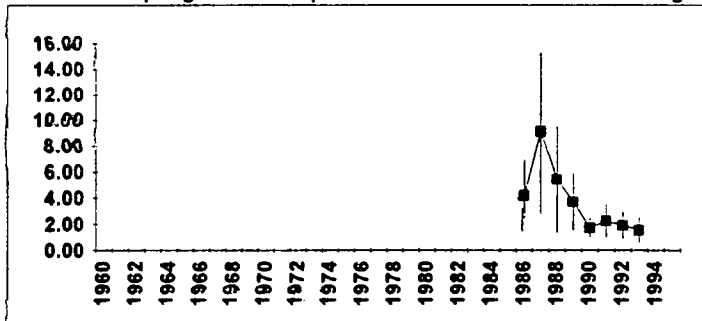
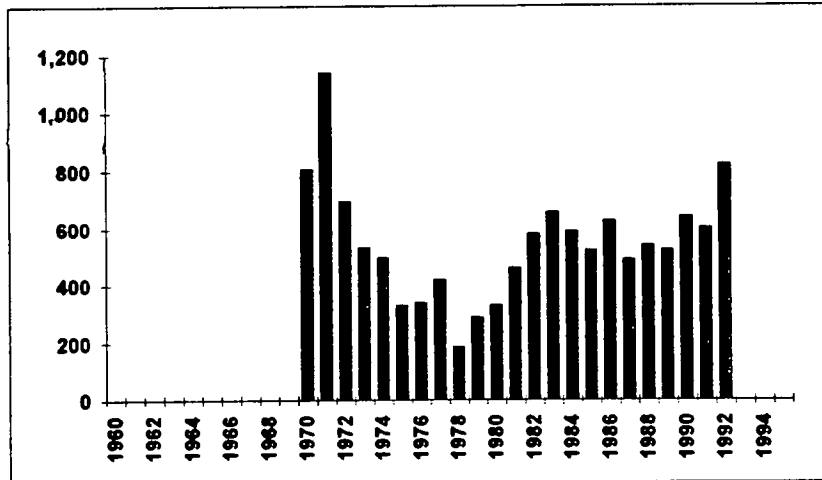

Fig. 1. .21c. Spring RV Mean # per tow All ages



Witch in 4X

Fig. 1. .22a. Total catches (t)



Whitch in 4X

Fig. 1: .22b.

Summer RV Mean # per tow

All ages

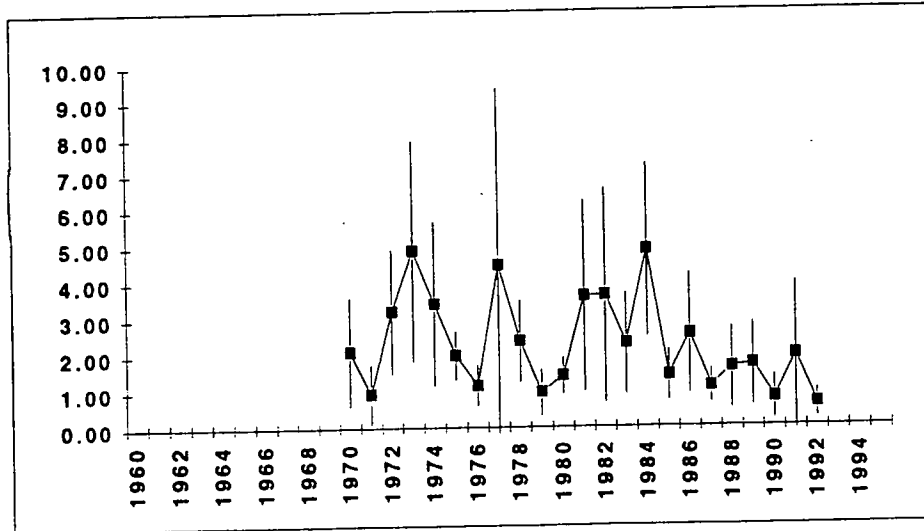

Yellowtail flounder in 4VW

Fig. 1: .23a.

Summer RV Mean # per tow

All ages

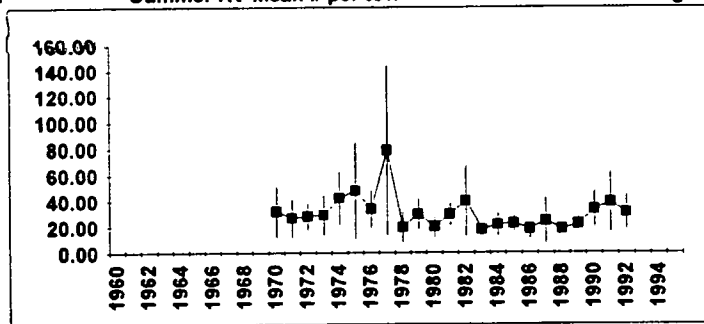

Fig. 1: .23b.

Spring RV Mean # per tow

All ages

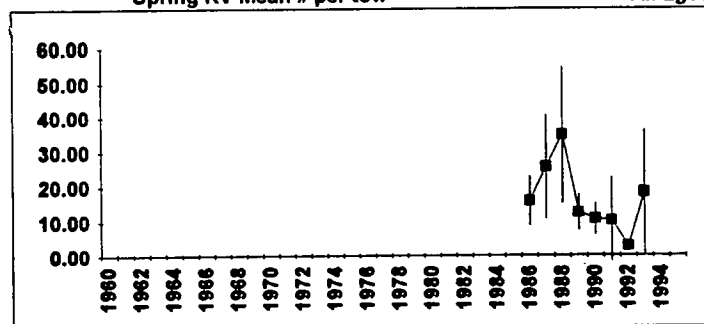

Fig. 1. 24a. Summer RV Mean # per tow All ages

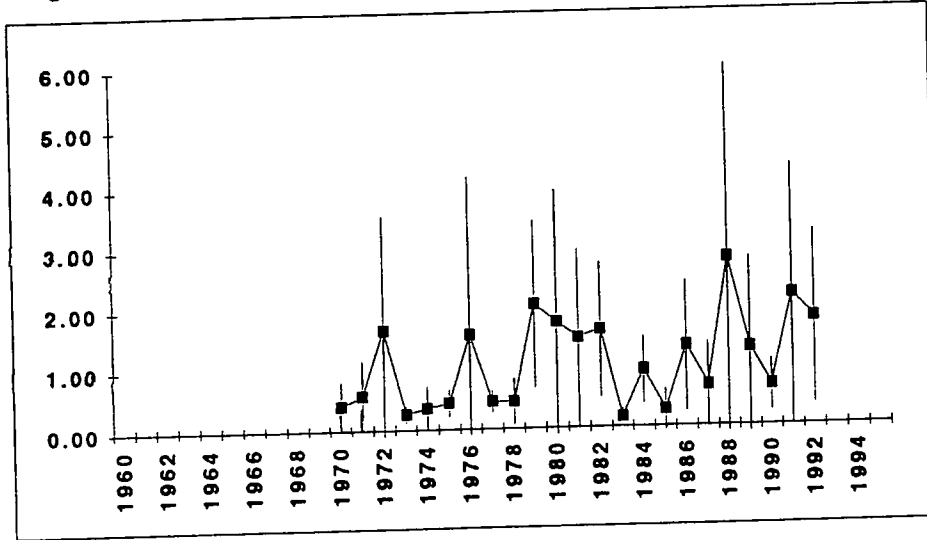

Fig. 1. 25a

Atlantic Halibut in 3NOPs4VWX

Total catches (t) and TACs (t)

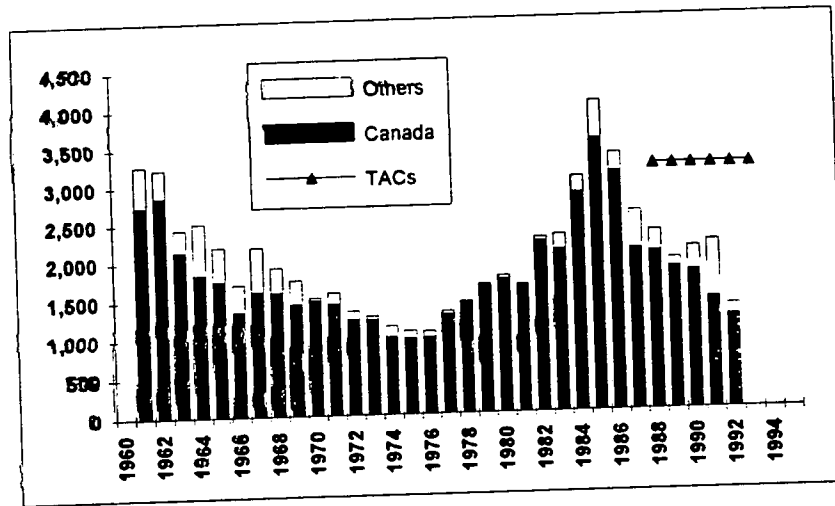
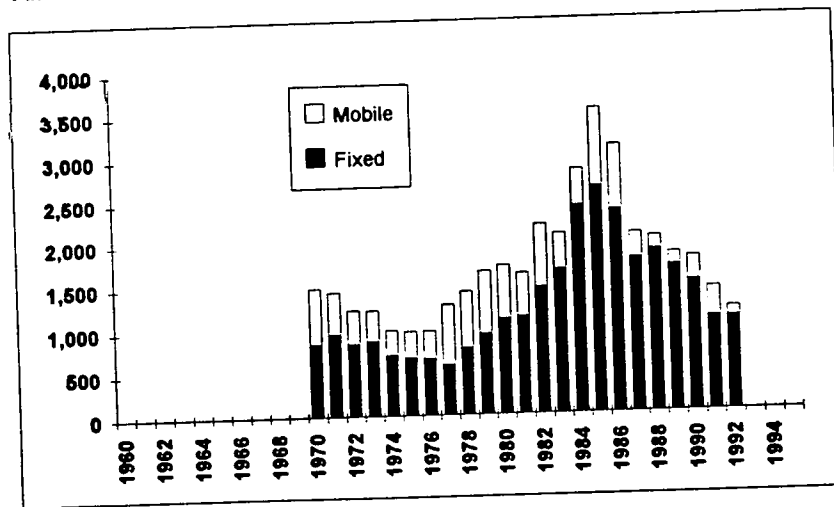

Fig. 1. 25b.

Fixed and Mobile Canadian Catches (t)



Atlantic Halibut in 3NOPs4VWX

Fig. 1 .25c.

RV - 4VWX summer (#/tow)

All ages

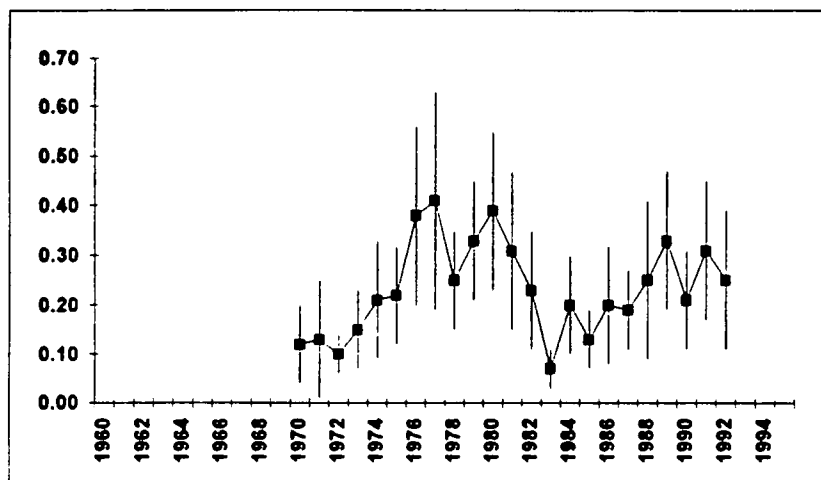

Fig. 1 .25d.

LL CPUE (t/1000 hooks)

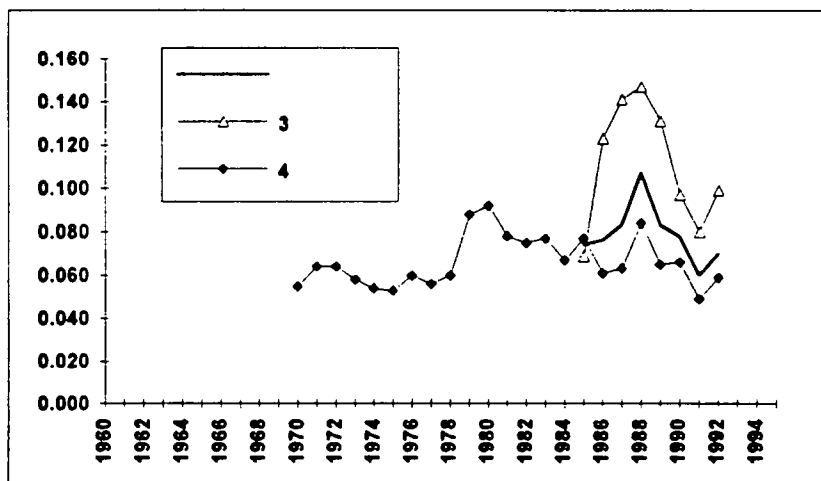
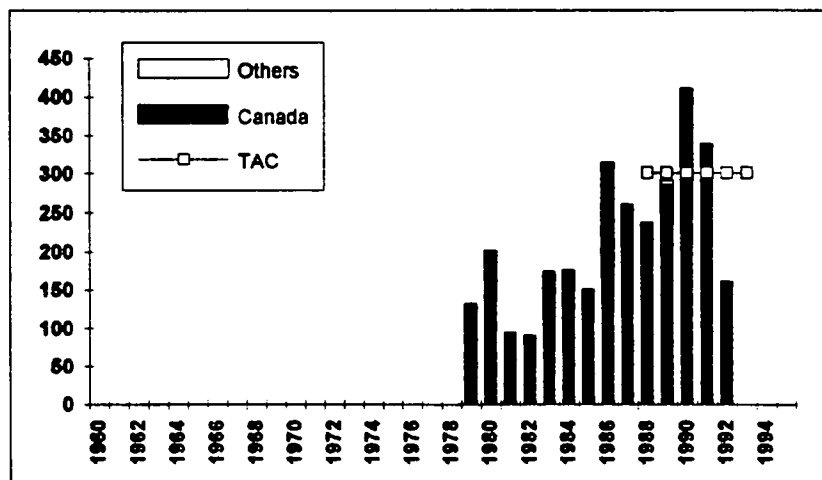

Fig. 1 .26a.

Atlantic Halibut in 4RST

Total catches (t) and TACs (t)



Greenland Halibut in 4RST

Fig. 1.27a. Total catches (t) and TACs (t)

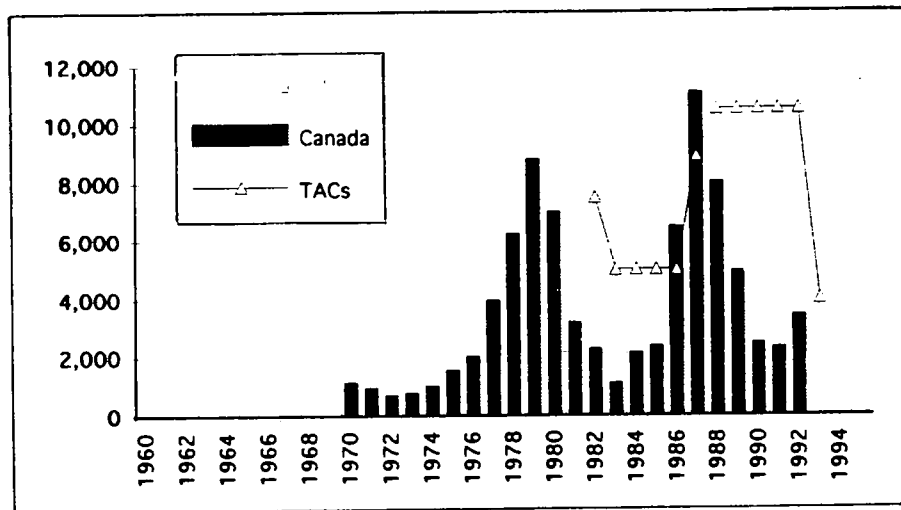

Greenland Halibut in 4RST

Abundance Indices

Fig. 1.27b. L. Hammond biomass estimate (t).

All ages

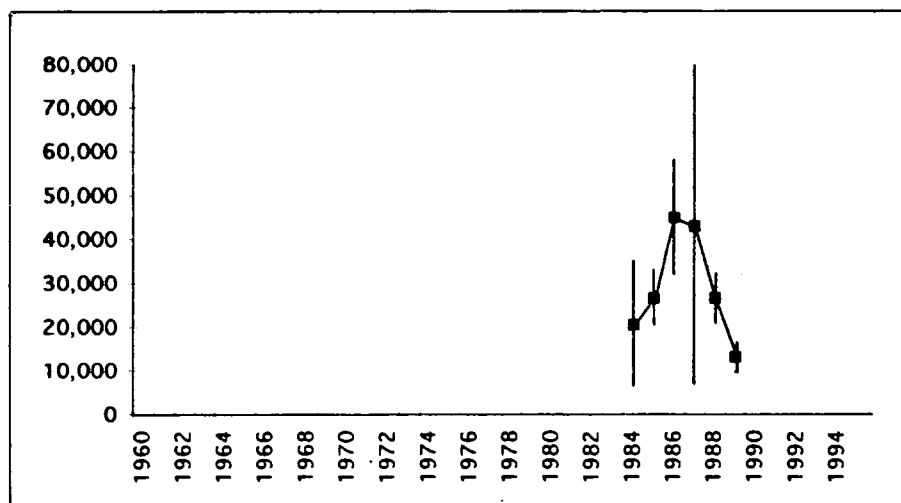
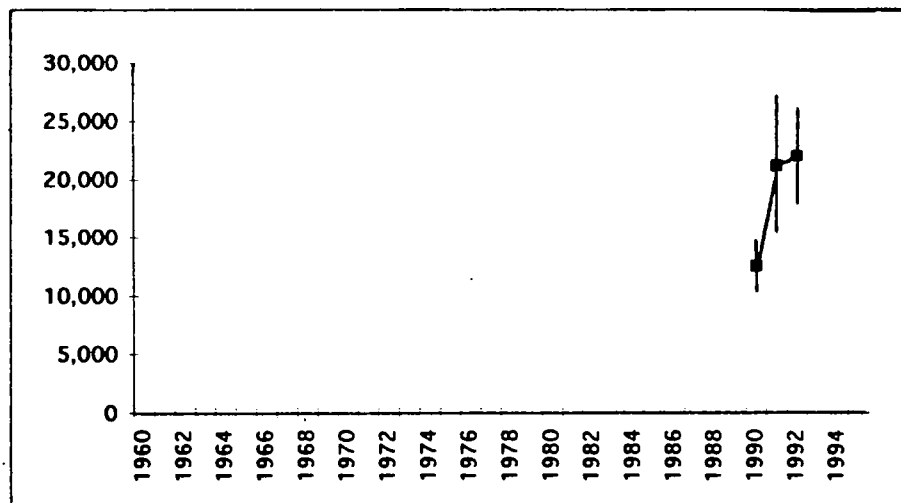

Fig. 1.27c. A. Needler biomass estimate (t).

All ages







#### 4. Descriptive narratives

##### 4.1. 2J3KL COD

#### SUMMARY

The northern cod stock continues to decline. The biomass is probably at its lowest level in this century and could be as low as 100,000 to 150,000t. This is lower than annual landings as recently as 1991.

If the stock is actually as low as recent surveys suggest, any catch may hinder its ability to rebuild. Because most recent year-classes have been weak and because northern cod do not spawn until about age 7, substantial recovery of the spawning biomass -- the total weight of fish old enough to spawn -- is unlikely before the year 2000 at the earliest.

Recently less than 40% of the fish present at the beginning of each year are still there at the end of the year. The fishery alone cannot account for this. A variety of other possible causes include harsh climatic conditions, low food supply, predation by seals or competition with seals for food, and migration out of the area.

The inshore "recreational fishery" should be closely monitored and if possible reduced. Any offshore fishing will diminish the spawning biomass. Recovery depends on these fish and on suitable survival conditions for eggs, larvae, juveniles and adults. During the winter of 1992-1993, most of the remaining stock has wintered on the Nose of the Bank, where foreign trawlers have been fishing.

#### ANALYSIS

Data from all available sources point to an ongoing decline. The annual groundfish trawl survey during the Autumn, 1992, estimated 70% less fish than the year before. There were fewer fish in all three NAFO Divisions (2J, 3K and 3L) than at any time since the surveys began.

Wide-ranging hydroacoustic (sounder) surveys since 1991 show a large and continuing decline in fish density, especially this year (February 1993). A tagging cruise in January, 1993, fishing the shelf edge from Hamilton Bank to the Nose of the Bank at depths of between 150 and 600 meters, found no concentrations of cod large enough to warrant tagging. In February, the only large concentrations the acoustic survey could find were on the Nose of the Bank outside the normal survey area, in waters 930 meters deep.

There is conflicting evidence on what has happened to this stock, and when the major decline took place. At first, examination of both DFO's trawl and sounder surveys and the offshore fishery suggested an abrupt decline in the first half of 1991. Closer examination suggested that the decline may have been more gradual beginning in NAFO Division 2J, off southern Labrador, in 1990.

A variety of indicators suggest that significant changes in the ocean have been underway since the late 1980s. For example, either the abundance of capelin has dramatically decreased or its distribution is completely changed since the autumn of 1990. Cod have been in poorer condition since 1989, especially in 2J. Northern cod have been moving south and moving deeper for several years. By autumn, 1992, more than 80% of the biomass was in NAFO Division 3L (compared to a historical average of about 30%). The sharp decline in the spawning biomass reflects a loss both in the absolute numbers of fish and in the average weight of individuals. Recently, for example, the average weights of fish aged 4-7 have been the lowest since the early 1970s. The smaller size and the lower number of mature adults has several implications. Small females produce fewer eggs, so that a spawning population of smaller fish may be less productive. Also, the spawning period may not last as long for younger fish. This could mean less chance that a high number of eggs and larvae survive.

Changes in the abundance, distribution and condition of cod and other species appear to be related to a cooling trend in the area through the 1980s. Too little is known about the basic ecology of the northwest Atlantic to be precise about causes and effects. Whatever the role ocean conditions have played in the collapse, it is clear they will determine the pace and perhaps even the possibility of recovery. Stock rebuilding will depend on the appearance of several strong year-classes and on their survival to maturity. Ocean conditions heavily influence the survival of cod eggs and larvae, and thereby the strength of each year-class recruited to the fishery as young fish grow up. The last abundant year-classes were born in 1986 and 1987. These were both preceded and followed by years of low survival, so that most of the biomass now consists of fish aged six and seven.

Recent studies tend to confirm the existence of inshore "sub-stocks" of northern cod which winter in some of the bays of the northeast coast. This raises the possibility that inshore spawning may be more important to the overall strength of the stock than was previously believed. Annual groundfish surveys do not go close to shore because of untrawlable bottom and therefore miss these fish, so their abundance is unknown. The severity of the effect of the recreational fishery on these inshore fish is also unknown.

The environment of northern cod continues to be colder than the long-term average. Near record low air temperatures persisted over the adjoining coastal area throughout 1992. Cold air and strong northwesterly winter winds led to earlier formation, wider extent and longer duration of sea ice than normal. Near-bottom water temperatures at Station 27 were slightly warmer than 1991, but continue the cool trend observed since 1983. Similarly, the extent of the Cold Intermediate Layer, a body of water with temperature less than 0° C, was lower than 1991 but larger than the long-term average. Bottom temperatures throughout the 2J3KL area, measured in the fall groundfish survey, were below the 10-year average in 1992.

## ASSESSMENT

The population model used by fisheries scientists worldwide, as applied to northern cod, assumes that about 18% of the fish die each year of natural causes. Scientists know that the actual rate of natural mortality will vary from time to time, but the stock assessments which use this assumption have been satisfactory until recently. However the recent decline of northern cod has been too extreme to be explained by fishing alone. Scientists believe it is no longer appropriate to assume a constant natural mortality of 18% for recent years, but they are unable to determine a more appropriate number, so they have not used the model to estimate the current size of the stock.

Results of the latest groundfish survey, which is normally just one ingredient of the assessment process, suggest that the biomass could be as low as 100,000 to 150,000t.

### **BACKGROUND**

Landings from the northern cod stock since 1959 have ranged between a high of 810,000t in 1968 and a low of 44,000t in 1992.

In June, 1991, CAFSAC believed that the stock was still recovering from its low in the early 70's, and advised that a proposed TAC of 185,000t would allow for continued growth. However, the poor commercial fishery that year, followed by much lower than expected results in the 1991 groundfish survey, led to a reassessment in January, 1992. With all indicators pointing steeply down, scientists recommended that the catch in the first half of the year be cut in half from the year before, to about 25,000 tons.

In the formal assessment that followed, both CAFSAC and NAFO calculated that the total biomass and the spawning biomass were at or near the lowest levels ever observed. CAFSAC recommended that the catch be held as low as possible. The cod moratorium was put in place in July 1992.

Total catches in 1992, before and after the moratorium, were about 44,000t. The reported Canadian catch was 23,796 tons; France reported landings of 583 tons; Canadian surveillance estimates of foreign landings of cod on the Nose of the Bank were 14,300 tons; the "recreational fishery" took an estimated 5,000t, additional to that 5,000t included in the reported catch.

#### 4.2. 3Ps COD

##### SUMMARY

This stock has been in decline since the late 1980s. The rate of decline should slow as the relatively strong 1987 and 1989 year-classes continue to grow. Although the 1993 TAC of 20,000t represents a considerable reduction from catches in previous years, it may still produce an exploitation rate higher than  $F_{0.1}$ . Stock growth will require both reduced fishing effort and higher recruitment.

##### ANALYSIS

Problems in getting consistent information often hinders the estimation of the abundance for many stocks. Reliable estimates require a stream of comparable data collected under similar circumstances year after year.

The stock assessment therefore relies on bottom trawl research vessel surveys conducted by Canada since 1972 and by France since 1978. The French discontinued their survey after 1992. It is important to stress that estimates based on trawl surveys alone represent the "minimum trawlable biomass", not the total stock. In 3Ps, an unknown portion of the stock is out of the survey's reach; but this is assumed to be fairly constant from one year to the next, so that surveys should indicate trends in the stock.

The trend was increasing in the mid-1980s, and Canadian surveys suggested a minimum trawlable biomass of 85,000t in 1988. This was followed by a decline, then two slight increases, then a large decline in 1992. The estimate for that year was only about 16,000t. The validity of the 1992 survey results that led to this estimate was uncertain; evidence from the commercial fishery suggested that an unusual number of cod may have moved to deeper water outside the survey area. To determine the magnitude of this problem, the stock was surveyed twice in 1993; in February and again in April, when more of the fish should be up on the bank within normal depths.

However, the 1993 survey results showed a continued decline. The February survey generated a minimum trawlable biomass estimate of 12,000t. The April estimate was even worse: only 7,800 tons.

The Canadian catch is taken chiefly by fixed gear fisheries. An adequate time series of catch and effort data from this gear sector is not available. Although catch and effort information are available from the Canadian and the French otter trawl fisheries, their interpretation has been difficult. French catch rate data may have been influenced by learning over time: as trawler skippers become more familiar with an area, increased fishing success does not necessarily indicate increased fish abundance. The French catch rate may also have been influenced by large changes in catches from one year to the next and by restrictions on where the vessels could fish. The age composition of the Canadian catch rates changed considerably more from year to year than would have been expected. These problems prevent using the catch rate information in the assessment.

## ASSESSMENT

The stock assessment, however, uses commercial catch data, in particular the weight and number of fish of each age, to create a numerical model of the stock. In effect, the process tries to answer the question: how many fish at each age must have been out there, at the start of the season, to have yielded these results? This modelling process has to make some assumptions about the growth rate and about how many fish die of natural causes. The model normally improves over time, because each year's catch data adds new information and shows up errors in earlier calculations. Normally, too, the model agrees with the trends which show up in trawl surveys, so that estimates of the total biomass can be made with some confidence.

In the case of 3Ps cod, catch at age from the commercial fisheries and indices of abundance from the research surveys were used in the assessments. The results are not very precise, perhaps because of changes in fish distribution of the 3Ps, 3Pn4RS and 3NO stocks. However, they indicate general trends, with the population declining since the mid 1980s and being presently the lowest or near the lowest observed.

## BACKGROUND

Cod landings from 3Ps ranged between 84,000 and 27,000t in the 20 years prior to 1979. Prior to 1978, the French catch was very low and was mostly landed by inshore boats from St. Pierre and Miquelon. Between 1960 and 1976, trawlers from other countries, chiefly Spain, fished heavily in 3Ps. By 1966 they were taking nearly as much as Canada. Altogether, the various fleets were taking from 40% to 90% of the spawning-age fish each year. The stock could not replenish these losses, so that landings declined until the late 1970s.

Fishing pressure eased after 1976, when the foreign fishery for cod ended in the area. Both the biomass and the landings began to recover. However Canadian landings, taken mostly by the inshore sector, remained very close to the 30-year average, so that France reaped most of the benefit of the stock recovery. Before the boundary decision, France took about 35% of the total catch, compared to less than 10% prior to the withdrawal of the foreign fishery. Up until 1977, inshore boats took most of the French catch. Since then trawlers have taken most of France's share. Trawlers from metropolitan France were prominent in the 3Ps fishery in the 1980s, especially after they were barred from the Gulf. However the metropolitan French trawlers have not fished in 3Ps since 1989. Trawlers from St. Pierre and Miquelon now land nearly all the French catch.

In the Canadian fishery, longlines take the largest portion of the catch, followed by gillnets, traps and handlines.

### 4.3. COD IN 3Pn and 4RS

#### SUMMARY

This stock may be at its lowest level in 20 years. The only reasonably large year-classes in the population were born in 1986 and 1987. These years were preceded and followed by years of poor recruitment. The spawning biomass of about 29,000t in 1992 is the lowest since 1974. Significant rebuilding will depend on future growth and recruitment.

TACs have been set at levels designed to achieve an exploitation rate of  $F_{0.1}$ , which is equivalent to catching about 18-20% of the biomass each year. However, similar to several other cod stocks, actual fishing mortality has been roughly double that rate, for reasons which are not clear.

#### ANALYSIS

This stock has in the past produced average landings of about 80,000t a year. Actual landings have varied between a high of 106,000t in 1983 and a low of 29,000 last year. Most of the fish in last year's catch were five-year-olds from the 1987 year-class.

The number of older fish in last year's catch was the lowest since 1974. The average weight of fish at each age was also the lowest since 1974. Low numbers, poor growth and poor recruitment mean that rebuilding the stock to the point where it can once again yield landings of 80,000t will be slow.

In the 20 years prior to 1990, year-classes ranged between 43 and 196 million fish. However, the average in the latter half of that period has been markedly lower, except for an estimated 140 million in 1987. Year-classes since then are thought to have been weak.

Enforcement problems have complicated the management of this resource in the past. These may have been eased recently by increased observer coverage and more stringent efforts to reduce the catch of small fish.

In recent years this stock has been surveyed in winter and summer. The winter survey, by the chartered research trawler *Gadus Atlantica*, occurs at a time when fish are migrating. This may affect our understanding of the distribution of these fish, but should not affect the biomass estimates if all the fish remain within the area surveyed. However, some northern Gulf cod may migrate into 3Ps in winter. Further studies are looking into this.

Since 1991, a summer shrimp/redfish survey in 4RST has been expanded into the shallower waters used by cod at this season. Because the winter survey by the *Gadus* may be discontinued after 1994, the usefulness of the results of the summer surveys as indicator of cod abundance will be assessed. Two new measures of fish abundance could compensate for the loss of the winter survey. One is an index fisherman program begun in 1990, which monitors the fishing success of selected individual inshore fishermen as an indication of stock abundance. Another will monitor the catch rates of selected mobile gear vessels.

**ASSESSMENT**

The number of fish aged three and over in this stock reached a low of 200 million in 1988. It increased slightly by 1990 and has been largely unchanged since then. As mentioned earlier, the stock now consists chiefly of fish spawned in 1986 and 1987, with poor recruitment from older and younger year-classes. A rough estimate of the 1990 year-class is 100 million individuals, which would be about equal to the long-term average. It is important to note that this year-class was prominent in the 1991 summer survey, but not in the same survey the following year. It could therefore be less abundant than 100 million individuals as presently estimated.

The spawning biomass, estimated at 29,000t in 1992, is the lowest since 1974.

---

#### 4.4. COD IN 4T & 4Vn (January to April)

##### SUMMARY

This stock has been declining since the mid 1980s and it is currently at its lowest level since about 1950. Further analysis and revised catch data suggest that the abundance in 1991 was at least 30% lower than was estimated last year. Fishing mortality -- the proportion of the stock which is caught each year -- appears to have nearly doubled since 1989. Although fish growth has improved slightly over the last few years, weights-at-age are still lower than those of the 1970s. Recruitment -- the survival of young fish to a catchable age -- has declined since the early 1980s.

##### ANALYSIS

When growth rates and recruitment are average, this stock should be able to produce landings of about 50,000t a year. Catches between 1950 and 1992 have varied between 104,000 and 22,000t, with an average of 56,000 tons.

The catch in 1991 fell to 47,000, and declined further to about 39,000 last year of which about 4,400 were taken outside of the stock area, primarily in 4Vsb. This was about 4,000t below the TAC. Fixed gear fishermen account for this shortfall. Their landings (3,742 tons) were the lowest since at least 1965. The otter trawlers were able to catch most of their allocation, despite several closures when the weight of fish less than 41cm in the catch exceeded 15% of the total catch. Estimates of discards were in the range of 10-11%, as in 1991.

Most fishermen believe the stock is down considerably from the mid-1980s. Catch rates have declined, but not as steeply as they might have without improvements to fishing technology.

More than 30% of the fish caught in 1992 were five-year-olds. It appears that fish of this age were successfully targeted by the fishery in 1992. Fish from the large 1979 and 1980 year-classes, which had supported the fishery in the mid-80's, were not abundant in this year's landings. The average weight of mature fish at various ages was higher last year than in 1991, but still much lower than during the 1970s.

The research vessel Alfred Needler replaced the Lady Hammond for the abundance survey on this stock. Comparative fishing experiments held before the changeover allowed to adjust the Needler's catch rate data to make it comparable with the Lady Hammond data from earlier years. Survey estimates, based on numbers of fish per tow, have been declining since about 1986. Four and five-year-old fish were the most abundant in the 1992 survey despite being at the lowest levels observed for these ages since 1977. The survey found a distinct tendency for fish aged three and four to occupy shallower waters than the fish aged five and older. This pattern has been seen before in periods of low abundance.

##### ASSESSMENT

To calculate the abundance of this stock, the assessment depends chiefly on two sources of data: the catch rates in commercial otter trawls and the numbers of fish per tow in the research surveys. The data from



each of these sources is analyzed using a variety of population modelling techniques, and biomass is estimated based on which of these seems most consistent with the others, and with trends in the commercial fishery.

All analyses indicated that the stock had been declining since the mid-1980s and was currently about the lowest since 1950.

Recruitment in recent years has been well below average. The 1987 year-class is now estimated at about 63 million fish, well below the long-term average of 87 million fish of this age. Changes in the ocean climate may have influenced the survival of young fish in recent years. Population biomass and abundance have been declining since the mid 1980s, and the spawning stock biomass is at about the lowest level in 20 years.

Since recent year-classes have been weak, biomass is not likely to recover significantly until recruitment improves.

#### 4.5. COD IN 4VsW

##### SUMMARY

The spawning stock and the fishable biomass are at the lowest levels since 1970. More than 60% of the fish are dying each year from fishing and natural mortality. Nearly all the fish remaining are at or under the legal size. As the stock has declined, fish have concentrated in a smaller area, which could have made them more vulnerable to fishing.

The requirement that fishing be stopped when more than 15% of fish landed are below the legal size has severely curtailed the fishery in 1993. If the 1993 TAC of 11,000t is taken, the spawning stock biomass will continue to decline. At such low biomass and given the recent poor survivorship of juveniles, any recovery will be slow.

##### ANALYSIS

Catches from this stock ranged between 40,000 and 80,000t from 1958 to 1974, then fell to a low of 10,000t in 1977. Catches climbed quickly back to 50,000t after Canada took over jurisdiction. However, quotas and landings have fallen since then. The catch was down to 29,800 in 1992. As of the end of May, the 1993 catch was only 500t, compared to about 15,000t by this date in previous years.

Before 1980, Division 4W and Subdivision 4Vs each contributed about half the catch from this stock. Over the next eight years, the proportion caught in 4Vs climbed to 87%. The balance has begun shifting back since then. Roughly 70% of the catch is taken by otter trawls, 25% by longline and the remainder by seines and gillnets. Some fishermen complained of the difficulty of finding legal-sized fish in 1992. There were reports of many tons being discarded in order that a few might be landed.

Fishing effort has become more concentrated in recent years with an apparent contraction in the distribution of the stock. As well, there has been seasonal shift due to the disappearance of the the spring fishery on spawning aggregations in 4W. Trawler catch rates may not be a reliable index of fish abundance when fish are more concentrated, so population estimates do not use this data.

##### ASSESSMENT

Research surveys of this stock are conducted in March and July. They show increasing abundance in the late 1970s, some fluctuations in abundance in the early 1980s and a decline since then. The survey in March, 1992, showed the lowest number on record. This may be extreme, given that the next two surveys, in July and the following March, were somewhat higher.

The surveys indicate that the year-classes born in 1986 and 1987, especially the latter, are the largest in recent years, however they are still lower than the long term average. The 1987 year-class has made up more than 45% of the number of fish in the surveys conducted since these fish grew big enough to catch.

---

The most recent calculation of stock size indicates that the spawning biomass is extremely low, comparable to levels in the mid 1970s when the stock was severely depleted. In recent years, recruitment – the number of fish surviving to a catchable size – has declined well below the long-term average. The 1987 year-class, for example, while the largest for some time, is a little more than two-thirds of the long-term average.

The 1992 summer survey has shown a high percentage of small fish indicating a low fishable biomass. The March, 1993, survey found few cod above the legal size. Catch data from the commercial fishery confirm this. These signs all suggest a resource depleted to the point where even the lower catches of recent years are taking more out of the stock than natural growth can put back.

### **POSSIBLE CAUSES**

There are several possible causes of this rapid decline.

The first is that the stock may have reached a state where the efficiency of fishing increases substantially. For example, if a smaller stock gathers more densely in a smaller area, the same level of fishing effort would remove a higher proportion of the fish. The remainder would occupy an even smaller area, and be that much more vulnerable to fishing. Similarly, as the average size of fish declined, it would take more fish to make the same tonnage and this again would mean a higher percentage rate of mortality. Interactions between various factors, such as temperature, prey or predator distribution, could magnify these effects.

Recruitment has been low from 1985 to at least 1989, even though the spawning biomass in that period was fairly high. The apparent disappearance of spring spawning may be a cause of this low recruitment, or it could be a symptom of some other cause. In any case, low recruitment at a time of high spawning biomass suggests a very poor survival rate for cod in their first three years of life. Now that the spawning biomass is extremely low, continued poor survival of the young would make it hard for the stock to recover.

There is much evidence that oceanographic conditions have changed on the eastern Scotian Shelf since 1985. Water temperatures near the bottom have been unusually cold, especially in 4V. Capelin, a cold water species, has been more abundant in the area since the mid-1980s. Nonetheless, more analysis is required before the link between fish production and ocean climate can be verified.

Based on the number of grey seal pups born on Sable Island in 1990, the age 1+ population was about 61,900 in that year. Numerous studies of the grey seal diet, based chiefly on the contents of stomachs, show the seals eat herring, cod, mackerel, sand lance and silver hake. Most fish eaten are from 15-35 cm long, which in the case of cod would mean fish 1-3 years old. There are still many uncertainties about what foods grey seals prefer, how much they need and where they are at different seasons. This makes it difficult to calculate confidently their impact on 4VsW cod at this time. A full evaluation is planned for later this year. Survey data on the abundance of cod at different ages show that more fish are dying as they approach the legal size. This suggests that overfishing and discarding may have more effect than seals, because seals are eating fish substantially smaller than the legal size.

#### 4.6. COD IN 4X

##### SUMMARY

Biomass estimates based on survey results indicate this stock is down by about 10% from 1992 and has been declining rapidly since 1990. The stock is now at or near the historic low. The decline has not been as critical as in other cod stocks farther north, but a lower rate of exploitation would allow rebuilding, producing higher catch rates and higher yields in future years.

Catches have fluctuated irregularly over the years, with a general downward trend. The fishery is taking young cod as they reach legal size. This has two negative effects. First, taking fish when they are small provides a lower yield than capturing some of the same fish a few years later. Second, a fishery dependent on young fish is vulnerable to fluctuations in "recruitment" -- the survival of fish to a catchable size. This is inherently unstable.

##### ANALYSIS

Landings from this stock have averaged about 20,000t since 1960, with peaks in 1968, 1982 and 1991. The catch in 1992 was 26,000t and equal to the TAC, which was set at that level for 1991-93. This is higher than reported catches in the late 1980s, but the earlier numbers may be less reliable.

Fish hatched in 1987 and in 1989 were prominent in both the otter trawl and longline catches in 1992. Fish from the 1985 year-class, which had been important in previous years, were greatly reduced by last year. Trawl surveys in recent years also found the 1985 and 1987 year-classes to be stronger than most. The surveys indicate a stock decline of about 10% by weight and 25% by numbers between 1991 and 1992. However, these results are not 100% certain because the survey cannot cover nearshore areas due to rough bottoms and the fraction of the population being close to shore may vary from year to year.

The survey has not been a reliable indicator of the abundance of young fish, which tend to be more common near shore.

Catch rate data from 139 commercial vessels show an increase from 1987 to 1989 and a decline thereafter with a marked increase in fishing effort between 1990 and 1992. Commercial catch rate data have not been used in the population model to calculate stock abundance, because of suspected misreporting and under-reporting in past years.

##### ASSESSMENT

The assessment of cod in 4X has involved the use of two statistical models of the population. With these, using the trends from the trawl surveys, and the catch data from the fishery, the abundance of fish at each age and the proportion taken by the fishery was estimated. Over time, as new catch and survey information is added to the model each year, this technique can build a fairly clear picture of the abundance of each year-class. However, the models provide a clearer view of the past than of the present or future.

With some stocks, this modelling approach suffers from a strong "retrospective pattern". For reasons which are not clear, estimates of the abundance of some year-classes have to be lowered as new data becomes available. Despite these limitations, the modelling techniques used in cod stock assessment are considered the best available. In the case of cod in 4X, the retrospective pattern seems to apply only to the younger year-classes and is not as severe as in other stocks. These, however, now make up most of the stock.

The results of the two models used were essentially the same. They indicate that the 1985 and 1987 year-classes were among the strongest since 1970. Apart from these two years, recruitment has been lower than average during the 1980s. The biomass has declined rapidly from a peak in 1990. It is worth noting that the peak in the early 1980s, sustained by stronger recruitment, lasted longer than the peak in 1990. The latter depended almost entirely on the 1985 and 1987 year-classes, and dropped as these were fished down.

The assessment has assumed average recruitment between 1990 and 1993. However, if these incoming year-classes continue the trend of lower recruitment, the future of this stock could be worse than the model indicates.

If the 1993 TAC of 26,000t is fully taken, the total biomass will decline from an estimated 68,000t in January 1993 to 47,000t the following year. If the TAC of 26,000t in 1993 is taken,  $F_{0.1}$  catches in 1994 would be about 7,000t. A 1993 catch of 18,000t would be roughly similar to the fishing pressure on the stock in recent years, and would leave a biomass of about 55,000t next year.

The biomass has fluctuated between 50,000 and 80,000t since 1970 and is currently at about its lowest level. Lower quotas would distribute the available yield over more years, give higher catch rates, and maintain a larger spawning biomass over the long term.

#### 4.7. COD ON GEORGE'S BANK (5Zj and 5Zm)

##### SUMMARY

Only an immediate and substantial cut in the harvest of this stock can slow the decline it has experienced in recent years. Because the fish are caught on both sides of the boundary between Canada and the U.S., this will require consistent management between the two countries.

The fishery is now highly dependent on young fish, and therefore subject to fluctuations in abundance. Sustained catches on the level of 1991 and 1992 would remove more fish than natural growth can replenish. Because these are fast-growing fish, spawning as young as age three, a few years of good recruitment and lower catches could build the stock back quickly.

##### ANALYSIS

Cod landings from this area between 1978 and 1992 peaked at 26,000t in 1982, averaged about 15,000t between 1983 and 1987, then increased to 20,000t in 1988. Landings have fallen since then, to about 17,000 in 1992. Canada takes about 65% of the total. Historically, the Canadian fishery in this area has been dominated by otter trawlers but in recent years longlines and gillnets have taken nearly half the Canadian share.

Because these cod grow quickly, fish as young as two years old are above the legal minimum and are taken in the fishery. In 1992, 42% of the fish in the commercial catch were two-year-olds, hatched in 1990. This was the highest catch of fish this young since 1987, when the strong 1985 year-class was entering the fishery. This year, small Canadian draggers were allowed to begin fishing in January. Roughly half their catch was from the 1990 year-class. However, a substantial portion of the catch was larger, spawning fish. Study of catch and effort of the Canadian trawler fleet show catch rates in decline and effort increasing, except for 1992, when the introduction of individual boat quotas may have altered the picture.

Both Canada and the U.S. carry out trawl surveys of this stock, Canada in the spring and the U.S. in spring and fall. Average catch per tow in the Canadian surveys declined sharply in 1991 and 1992. U.S. survey catches in the same period have been the lowest on record. The trawl surveys confirm a strong, persistent pattern of migration back and forth across the international boundary. Fish younger than age four seem to migrate more than the older cod in this stock. Generally speaking, the fish move into the Canadian zone for the spring and summer, and out of the zone in the autumn and winter. However, the number found in either zone can vary considerably from one year to the next. For example, the proportion found in the Canadian zone in spring and summer has ranged between 20 and 100%. This wide variability complicates the calculations of biomass and estimates of the impact of various levels of fishing effort by the Canadian fleet.

##### ASSESSMENT

The abundance estimates for this stock have an unusually wide margin of error. However, while the biomass estimate for any one year is quite imprecise, the trend is clear; the stock has suffered a large decline. The total biomass and the spawning stock biomass are at the lowest level in years. Fishing mortality -- the

proportion of the stock taken each year in the fishery – has been rising almost continuously since at least 1986.

The research surveys indicate that the 1991 and 1992 year-classes were well below average, so that fish hatched in 1990 will account for a large share of the landings in 1993. About half of these fish will still be immature.

The low biomass, high mortality and poor recruitment are cause for serious concern. The fishery, especially the mobile gear sector, is very dependent on young fish. Catching them so young means a low yield from the resource and a considerable sacrifice of the spawning biomass.

Because so much of this resource migrates into U.S. waters, restrictions to the Canadian catch alone will not reverse the decline. Canada and the U.S. may have to apply consistent management to rebuild this stock on a sustained basis.

---

#### 4.8. HADDOCK IN 4TVW

##### SUMMARY

This stock has been heavily exploited, the spawning biomass is low and year-classes since 1988 have been weak. Rebuilding the spawning biomass depends on the 1988 year-class, which now makes up the bulk of the stock. Continued fishing at the current level will greatly diminish the contribution these fish can make to stock recovery.

##### THE FISHERY

Landings averaged 26,500t a year from 1950 to 1969, fell to an average of 5,000t during the 1970s, and have ranged between 6,000 and 20,000t since then. The catch in 1992 was about 6,000t.

By 1987, after several years of low recruitment, the fishery was dependent on only two year-classes of haddock. This, and a low spawning biomass, led to measures to restrict the fishery to a 5% bycatch. The following year this was raised to 15%, a limit that remained in force through 1990. In 1992, the management approach changed to a combination of by-catch restrictions and trip limits.

Fishing in the haddock nursery area in 4W, mainly Emerald and Western Banks, was closed to mobile gear in 1987. However, fixed gear vessels have been allowed a directed haddock fishery in that area until this year. Until 1984, trawlers fishing in Division 4W took most of the catch from this stock. That year 4W was closed to trawlers from May to December, to protect the large year-classes of the early 1980s. The trawler fishery shifted to 4Vs, which was soon producing about half the haddock landings from this stock. Since 1990, however, landings from 4Vs have fallen to 780t. Meanwhile, the fixed gear fishery in 4W enjoyed a five-fold increase in landings after 1987. By 1991, trawler landings were down to only about 35% of total landings, while longlines took 63%. The longline catch in 1992 was the highest ever, at 3,494t. The trawler catch tripled that year, to 1,324t, with most of it coming from 4W in areas adjacent to the closed zone. The average size of fish was small, dominated by the 1988 year-class.

Inshore landings of haddock in 4W have declined steadily for 15-25 years, and more steeply in recent years. Inshore fishers also report changes in the migration of "inshore haddock". They describe these fish as different from offshore haddock in their colour, shape, taste and size.

##### DATA

Over the past year, questions have come up about the accuracy of methods currently used for aging haddock. The effect of the error would be to underestimate the age of older fish. The severity of this problem, if it exists at all, is still under study.

Regulation of the haddock fishery by trip limits and by-catch restrictions makes it difficult to use commercial catch rates as a measure of fish abundance. In the scientific surveys, however, catches increased in the late 1970s and early 1980s. In the summer surveys, catch rates have risen after 1987, due to the large 1988 year-class. Most of the survey catch comes from 4W. There has been very little haddock in 4Vn since the large year-classes of the early 1980s. Catches in 4T and 4Vs have been negligible. Exceptionally cold water



---

may explain the absence of haddock in Division 4V; these fish avoid waters below 4 C. Average bottom temperatures in 4V have been below 2.5 C over the past four years. Bottom temperatures in 4W have declined as well, but not as severely; the average in July has remained above 5 C.

A comparison of the last spring and summer surveys in 4W shows very little difference in the size of fish in the 1988 year-class between July and the following March. This could mean either poor growth or a high mortality among the fish which had grown to a catchable size. Recent surveys also show the presence of haddock in the 18.5 cm range. It is not clear whether these were fast-growing one-year-olds or slow-growing two-year-olds.

### **ASSESSMENT**

Analysis of commercial catch and survey data shows that the fishery has been taking a high proportion of larger fish (46.5 to 60.5 cm). This probably reflects both low numbers of large fish and the displacement of the trawler fleet from the closed area. Estimates of fishing mortality on the smaller fish show three distinct periods. The peak was from 1970 to 1976, before the 200-mile limit, when foreign vessels fished with small mesh gear on the Scotian Shelf. The exclusion of these vessels after 1977 reduced the fishing pressure on small fish. Banning trawlers from the nursery area in 4W also decreased fishing mortality on the smaller sizes, but may have led to greater exploitation of larger fish in other areas.

Spring and summer surveys both indicate that the haddock stock is now concentrated in 4W and consists mainly of fish spawned in 1988. The surveys have detected no large year-classes after this one. The 1992 summer survey caught no fish younger than one, and many fewer one-year-olds than usual.

The female spawning biomass of haddock has been in decline since 1981 and dropped to an estimated 4,000-8,000t in 1992. This is roughly as low as it was in the late 1970s, after years of trawling with small mesh gear.

### **PROGNOSIS**

It is not certain whether this stock can rebuild to the levels which produced average landings of 20,000t from 1950 to 1969. It is certain, however, that current levels of fishing pressure make such growth improbable on a sustained basis. The 1988 year-class is still fairly strong, but having most of the biomass contained in one year-class makes a fragile resource.

In any case, the 1988 year-class cannot remain strong if current levels of fishing continue. Reduced catches will accelerate the rebuilding of the spawning biomass and increase the possibility of strong recruitment. Without strong recruitment, this stock will remain low.

#### 4.9. HADDOCK IN 4X

##### SUMMARY

This is currently a fishery, in which mature fish are scarce and landings depend on the number of young fish which grow to a catchable size each year. Such a fishery is inefficient and vulnerable. However, moderate quotas and the relative strength of two recent year-classes should maintain the spawning stock biomass for the next several years.

Apart from the 1987 and 1988 year-classes, which were only average, recruitment has been below average for some time. Future growth will depend on a reversal of this trend.

##### THE FISHERY

Reported landings from this stock averaged about 20,000t between 1930 and 1988. They peaked above 30,000t in the mid to late 1960s, and during the 1980s. From 1982-84 and again in 1987-88, catches were below the TAC. They fell to 6,700t in 1989, when the scientific recommendation was that catches be kept as low as possible. That year, the mobile gear fishery was closed in mid-season.

In 1993, a directed fishery is permitted, with a TAC of 6,000t. This is about 30% more than the TAC in 1989 and 1990, but substantially less than actual haddock landings in 1990 to 1992.

The minimum mesh size for otter trawls was increased in 1991, which, combined with lower recruitment, reduced the capture of small fish. In the same year, individual transferable quotas (ITQ's) were introduced into the small dragger fleet (under 65 ft). ITQ's had a considerable impact on fishing strategies. Some vessels concentrated on flatfish, silver hake and shrimp, or fished in neighbouring 5Zj,m, some negotiated transfers of quotas between vessels, and some avoided areas where haddock were abundant. Overall, the catch of the ITQ fleet declined by 28% in 1992.

The fixed gear fleet fished on trip limits of 6,800 kg of 4X haddock until March 1, 1992, when the limit was reduced to 1,500 kg. This gear sector caught 6,468t in 1992, an increase, compared to 2,776t for the small draggers which decreased. Larger trawlers and the gillnet sector caught 419t and 251t respectively.

People in the industry say that misreporting of catches was common between 1985 and 1988, was low in 1989 and has increased slightly since. It may be that some of the reported increase in longline haddock landings results from transshipping catches from small draggers.

##### DATA

Recently discovered problems in aging haddock are not resolved. As a result, estimates of the abundance of different year-classes are based on the varying lengths of fish in surveys and in samples of the commercial catch. Haddock age 1 and 2 can be easily distinguished by length.

Judging year-class strength by the lengths of fish in the surveys from 1988 to 1992, indicates that the 1987 and 1988 year-classes are average, 1989 is very weak, and 1990 and 1991 are below average.

The size of fish in the commercial catch has been fairly consistent from 1978 to 1992, averaging between 49 and 53 cm. The proportion of small fish (under 44 cm) rose to 20% in 1983-86 and again in 1990. The increase in 1990 probably reflects the recruitment of the 1987 and 1988 year-classes, which were only average but were nevertheless much higher than the two years before.

Otter trawl catch rates have not been a reliable index of haddock abundance, because of high and variable levels of misreporting. In recent years, however, the longline vessels fished haddock with few restrictions, and therefore little incentive to falsify catch data. Analysis of their January and February haddock catch rate show a 25% increase from 1989 to 1992. The catch rates of research vessels were low during the 1970s and high in the early to mid-1980s. Catch rates declined to near-record lows from 1985-1987, then rose near the average to 1991, then dropped 50% in 1992.

## **ASSESSMENT**

Judging from the catch of research surveys, recruitment has been average or below average since 1983. The surveys have provided relative estimates of population size since 1970. They indicate that the female spawning stock biomass was below average during the early 1970s, peaked at about 30,000t in the late 1970s and early 1980s, fell back to average levels by the mid 80's and declined further to 9,000t in 1987-1989.

Since then, the appearance of two average year-classes in 1987 and 1988 have helped to rebuild the spawning biomass to about 15,000. This is still below the long-term average of about 19,000t since 1970. How much influence the spawning biomass has on the level of recruitment has never been clearly shown; but common sense and some statistical work suggests that with a large spawning biomass 4X haddock is more likely to thrive.

## **PROGNOSIS**

The 1987 and 1988 year-classes will probably continue to make up the bulk of landings for the next several years. The current TAC of 6,000t implies that as these fish grow, the proportion of the stock being taken in the fishery, that is the fishing mortality, will probably decline. This lower quota will help to maintain the spawning biomass and extend the period over which these two year-classes contribute to landings. Without strong recruitment, however, catch rates will decline as these fish are taken.

---

#### 4.10. HADDOCK IN 5Zj AND 5Zm

##### SUMMARY

Adult biomass estimates indicate that the stock is down by almost 50% from 1992, continuing a decline from 1990. The stock is now at or near the historic low. This stock straddles the maritime boundary between Canada and the U.S. Because most of the fish are on the Canadian side and migration is limited, conservation measures by Canada alone would benefit the Canadian fishery. But the stock is severely depleted, so the possibility of achieving recovery would be greatly enhanced if consistent restrictive measures were adopted by both countries. Restrictions on the Canadian side alone would not rebuild the stock but may prevent further depletion.

##### THE FISHERY

This stock has supported a commercial fishery since the early 1920s. Landings reached an all time high of 60,000t in the mid-1960s, and have ranged between 2,500t and 25,000t since then. In recent years, landings have fluctuated around 5,000t.

In 1992, recognizing the depleted state of the stock, CAFSAC recommended that the Canadian catch be limited to 2,500t. The Canadian industry, unconvinced of the value of Canada acting alone, lobbied successfully against quota cuts. The Canadian TAC remained at 5,000t, but Canada could only catch 4,000t because mobile gear vessels were unable to catch their allocation. Landings by the American fleet increased to 1,700t. The fishery was opened to trawlers on pre-spawning and spawning aggregations in January and February, 1993 for the first time in recent years.

##### DATA

The commercial fishery in 1992 was almost entirely supported by the 1985 and 1987 year-classes, which comprised over 70% of the landings.

The catch rates on research surveys indicate a decline in adult haddock over the last three years to amongst the lowest levels ever. The 1975 and 1978 year-classes were strong, while those of 1983, 1985 and 1987 were average. Recruitment since then has been low. The strength of the 1992 year-class is not well estimated, but early indications suggest that it is moderate, comparable to those of 1983, 1985 and 1987.

The catch rates of 51 small druggers which fish for haddock on Georges Bank show an increase to 1989, a sharp decline in 1990 and low catch rates since then. Trawler effort rose substantially during 1990-1992.

##### ASSESSMENT

Canada conducts research surveys on Georges Bank in March and the U.S.A. does so in March and October. These surveys have supplied the data for stock assessment and defined the migration of haddock across the international boundary. In general, the trend is for haddock to move to the northeast and to

deeper water in summer, returning to the bank in winter. The movement does not seem to be related to fish density or abundance.

It appears that only a small fraction of the total stock moves into U.S.A. waters. However, the continued appearance of haddock on the U.S.A. side, despite high exploitation, suggests that fish from the Canadian side keep replenishing the American side, regardless of how heavily the Americans fish them. At the beginning of the spring-summer period, about 85% of the fish are normally in Canadian waters. By the beginning of the autumn-winter period, nearly all are in Canadian territory. Details of this migration are important, because the distribution of fish will heavily influence the effectiveness of conservation measures, especially if Canada undertakes them alone.

The determination of stock status is based on analysis of the commercial catch information and abundance trends from the three research surveys. The 1983, 1985 and 1987 year-classes were the most abundant since the strong 1975 and 1978 year-classes. Other year-classes have been weak. The 1992 year-class could be of moderate strength, but it is too early to estimate its abundance reliably. The adult biomass in 1993 declined under 5,000t, near the historic low of the 1970s. The fishing mortality in 1992 was the highest observed and corresponded roughly to removing 60% to 70% of the 1985 and 1987 year-classes.

#### PROGNOSIS

Applying the most likely estimates of fish distribution and migration rates indicated that, for this transboundary resource, conservation measures by Canada could achieve the benefits of an  $F_{0.1}$  strategy: a stronger spawning biomass, more large fish, higher and more stable catches and a higher yield per recruit. Actions by the U.S.A. did not have an important effect. Under less favourable patterns of fish distribution and migration, Canada alone could probably not effectively manage this stock. That is, high fishing on the American side could defeat the benefits of moderation on the Canadian side. If Canadians concluded there was no point to moderation, yet the most likely patterns of distribution and migration prevailed, they would risk losing potential yield from the stock. These conclusions are based on recent patterns of haddock distribution and migration. With increased abundance, these factors could change and the conclusions could also change.

If the 1992 year-class proves to be as abundant as the 1983, 1985 and 1987 year-classes, the adult biomass will increase to about 10,000t in 1995 as it recruits to the fishery. The projected yield at  $F_{0.1}$  in 1994 would be about 2,000t, with the 1992 year-class accounting for about 70% of the landings. In the absence of any substantial standing stock, future catches are likely to fluctuate greatly in response to variable recruitment, potential yield may be lost as fish are harvested heavily as soon as they recruit to the fishery and before their growth potential is realized. In addition, there is a greater chance that undersized fish will be caught and have to be discarded.

In summary, poor recent recruitment and the severely depleted state of this stock warrant the pursuit of consistent restrictive measures by both countries to improve chances of accelerating a recovery and building up the adult biomass to levels which could sustain higher catches.

#### 4.11. POLLOCK IN 4VWX & 5Zc

##### SUMMARY

This stock has produced landings averaging about 37,000t since 1974. Catches in the 1980s were higher than average, sustained by the strong 1979 year-class. However, catches have fallen short of the TAC for three consecutive years, and fishing mortality is high. The number of fish aged four and over is about average, but the number of larger fish has declined in recent years.

The 1989 year-class could be above average, but will not contribute substantially to rebuilding the spawning biomass if fishing mortality remains high.

##### THE FISHERY

Pollock catches in this area have ranged between 25,000 and 46,000t since 1974. Landings and TAC's were stable in the late 1980s, thanks to the recruitment of strong year-classes in the first half of the decade. However, as these fish disappear, neither the mobile nor the fixed gear sector has been able to land its full quota since 1989.

Large trawlers dominate the pollock fishery in 4VW. Their catches doubled from 1974 to 1980, remained stable to 1989 and have declined since then. Small draggers predominate in 4X and 5Zc. Their landings have remained fairly stable since 1974. Landings by gillnets have declined in recent years.

Cuban and Russian vessels took 2,000t of pollock in this area in 1992, mainly as a by-catch in the silver hake fishery.

##### DATA

Pollock landings in most years are made up chiefly of three or four year-classes. In 1992, the catch of two and three-year-old pollock was the highest since the early 1980s. The 1989 year-class showed up strongly in the landings of the last two years. In 1991, it made the second largest catch of two-year-olds ever. The following year it made the third largest catch of three-year-olds.

Research vessel surveys show an increase in abundance of mature pollock in the early 1980s. Since then, results have varied widely from one year to the next, making it difficult to estimate year-class strengths. In 1992, the number of pollock aged 4-10 in the survey catch was the lowest since 1984, but the number of three-year-olds from the 1989 year-class was among the highest in 22 years.

##### ASSESSMENT

This stock was low in the early 1970s, peaked in the mid-1980s and has declined since. The 1979 year-class, which contributed to the good landings in the 1980s, numbered an estimated 76 million at age two; this was the second largest recruitment since 1974. Recruitment from 1980 to 1985 was near the long-term average of 28 million.

A preliminary estimate of the 1989 year-class puts it close to the record of 76 million. However, this estimate is based on only two years of catch data; a more confident estimate of the size of this important year-class will be possible as new commercial and survey catch data becomes available. In the meantime, stock projections use the long-term average of 28 million as the figure for recruitment of this group.

#### **PROGNOSIS**

The 1993 TAC of 35,000t implies a fishing mortality of about  $F = .55$ . To fish at the target level of  $F_{0.1}$  would require TACs of about 20,000t in 1993 and 1994. However, if the 1989 year-class proves to be as large as it appears so far, the  $F_{0.1}$  catch in 1994 could be higher.

#### 4.12. REDFISH IN THE GULF OF ST. LAWRENCE & CABOT STRAIT (4RST+3Pn(January-May)+4Vn(January-May))

##### SUMMARY

Redfish stocks tend to fluctuate widely in abundance. They are slow-growing, long-living fish, but good year-classes come along only periodically. For this reason, these strong year-classes dominate the catches while they last. The rarity of good year-classes makes it important to keep fishing mortality down, to stabilize landings and sustain the population until the next strong year-class appears.

The 1988 year-class appears to be strong, though perhaps not quite as strong as was previously estimated. However, it will not contribute to the fishery for another 3-4 years. In the meantime, the 1981 year-class cannot continue to support landings as high as those of recent years, especially those in 1992.

##### THE FISHERY

Redfish landings in this area increased steadily during the 1960s, reaching a peak of 130,000t in 1973. Landings then declined steadily to a low of 15,000t in 1978, and have climbed again since then, reaching 77,000t last year. Much of last year's increase was due to higher catches during the winter in the Cabot Strait.

TACs for the 4RST stock were introduced in 1976, but landings in the Gulf have been short of the TAC in every year but two. In 1992, CAFSAC recommended a TAC of 67,000t for a newly-defined management unit that included 3Pn and 4Vn in the Cabot Strait. However, the new management unit was not put in place in 1992. Instead flexibility in harvesting was allowed which resulted in a catch that exceeded the recommended TAC by 10,000t. In 1993, the TAC will be 60,000t for the new management unit.

##### DATA

Most of the catch in 1992 was from the 1981 year-class. Commercial catch rate data show three distinct peaks. The last one, in 1990, was the highest. However, the high catch rates since 1988 may be due to the introduction of a new midwater trawl. The catch rates of bottom trawls from May to October, when most redfish are in the Gulf and thought to be closer to bottom may be a better index of redfish abundance. This analysis also showed three peaks in the catch rates, but the one for 1990 was in line with the others.

Judging by the catch rates of recent research surveys, the abundance of fishable-sized redfish (longer than 25 cm) was about 800 million in 1990, 350 million in 1991 and 400 million in 1992. The abundance of fish smaller than 25 cm was about 1,400 million in 1990 and 1991, and dropped to 400 million in 1992. In terms of biomass, the estimate decreased by about 40% between 1990 and 1991, and by 20% in 1992.

The redfish in this area include two distinct species. One dominated the strong 1981 year-class, and the other the 1988 year-class. As the former is fished down, the other species will come to dominate redfish landings from about 1997 on.

##### PROGNOSIS

The 1981 year-class is now fully recruited into the fishery and will make up the bulk of landings for the next 3-4 years. If TACs remain at the 60,000 level, the exploitation rate will increase as the remaining biomass decreases. Catch rates will also drop, as they did when earlier strong year-classes were taken up in the 1980s. However, current landings are roughly double the catches in that period; if the year-class supporting this fishery is roughly equal to the last big year-class, the biomass will decline faster this time around, because the catches are higher.



---

**REPORT ON THE STATUS OF GROUND FISH STOCKS  
IN THE CANADIAN NORTHWEST ATLANTIC**

---



---

**Report on the Status of Groundfish Stocks  
In the Canadian Northwest Atlantic**

**Table of Contents**

Introduction .....	5
1. Overview of Groundfish Stocks	
1.1. General Overview of Commercially Exploited Groundfish .....	5
1.2. Overview of Commercially Exploited Groundfish on the Newfoundland Shelf and on the Grand Banks. ....	7
1.3. Overview of Commercially Exploited Groundfish in the Gulf of St. Lawrence .....	10
1.4. Overview of Commercially Exploited Groundfish on the Scotian Shelf and on Georges Bank .....	11
1.5. Environmental Conditions .....	14
2. Stock Status Summary Sheets	
2.1. Cod in 2J+3KL .....	16
2.2. Cod in 3Ps .....	17
2.3. Cod in 3Pn,4RS .....	18
2.4. Cod in 4T-Vn (January-April) .....	19
2.5. ✓Cod in 4Vs and in 4W .....	20
2.6. ✓Cod in 4X .....	21
2.7. ✓Cod in 5Zj and in 5Zm .....	22
2.8. ✓Haddock in 4TVW .....	23
2.9. ✓Haddock in 4X .....	24
2.10. ✓Haddock in 5Zj and 5Zm .....	25
2.11. ✓Pollock in 4VWX+5Zc .....	26
2.12. Redfish in the Gulf of St. Lawrence (4RST, 3Pn (Jan.-May) and 4Vn (Jan.-May)) .....	27
2.13. American Plaice in Subarea 2 and 3K .....	28
2.14. American Plaice in 3Ps .....	29
2.15. American Plaice in 4T .....	30
2.16. ✓American Plaice in 4VW .....	31
2.17. ✓American Plaice in 4X .....	32
2.18. Witch in 2J3KL .....	33
2.19. Witch in 3Ps .....	34
2.20. Witch in 4R and 4S .....	35
2.21. ✓Witch in 4VW .....	36
2.22. ✓Witch in 4X .....	37
2.23. ✓Yellowtail in 4VW .....	38

---

2.24.	✓ Yellowtail in 4X .....	39
2.25.	✓ Atlantic Halibut in 3NOPs and 4VWX .....	40
2.26.	Atlantic Halibut in 4RST .....	41
2.27.	Greenland Halibut in 4RST .....	42
2.28.	✓ Cod in 4Vn during May to December .....	43
2.29.	Redfish in 2+3K .....	44
2.30.	Redfish in 30 .....	45
2.31.	Redfish in Laurentian Channel .....	46
2.32.	White Hake in 4T .....	47
3.	Figures .....	48
4.	Descriptive stock narratives	
4.1.	2J3KL Cod .....	105
4.2.	3Ps Cod .....	108
4.3.	Cod in 3Pn and 4RS .....	110
4.4.	Cod in 4T & 4Vn (January to April) .....	112
4.5.	Cod in 4VsW .....	114
4.6.	Cod in 4X .....	116
4.7.	Cod on Georges Bank (5Zj and 5Zm) .....	118
4.8.	Haddock in 4TVW .....	120
4.9.	Haddock in 4X .....	122
4.10.	Haddock in 5Zj and 5Zm .....	124
4.11.	Pollock in 4VWX & 5Zc .....	126
4.12.	Redfish in the Gulf of St. Lawrence & Cabot Strait (4RST+3Pn (January-May) + 4Vn (January-May)) .....	128

---

## GROUND FISH STOCK STATUS REPORT

### Introduction

This report presents the results of groundfish stock assessments for the Canadian Atlantic for 1993. Stock assessments experts from the four DFO Atlantic regions and Headquarters have peer reviewed the assessments. Their report will be published shortly in the Canadian Technical Report of Fisheries and Aquatic Sciences series and it will be available from DFO Regional Offices.

Sections 1, 2 and the graphs from the present report are extracts from the full report while Section 4 is new. Section 1.1 is a global overview of groundfish stock status for the Atlantic Zone, while sections 1.2 to 1.4 are regional overviews for Newfoundland, the Gulf of Saint Lawrence and Scotia-Fundy respectively. Section 1.5 is an overview of climatic and hydrological conditions in 1992 compared with average conditions. Section 2 presents one page summary sheets for each stock similar to those produced by the Northwest Atlantic Fisheries Organization (NAFO) and the International Council for the Exploration of the Sea (ICES). The graphs are numbered to correspond with the numbers of the summary sheets. The first line of the tabular information on each summary sheet - Reference Level - refers to the advice that was provided by the former Canadian Atlantic Fisheries Scientific Advisory Committee (CAFSAC) for that year. Most of the time, CAFSAC provided catch advice at the  $F_{0.1}$  reference level, but other approaches have been taken, e.g. the 50% rule. Section 4 contains descriptive narratives for cod, haddock, pollock, and Gulf of St. Lawrence redfish stocks in the same order as that of Section 2 and of the graphs.

As was done by former CAFSAC, it is expected that the data on which the assessments are based as well as technical details on the analyses will be documented in research documents that will be publically available. Any comments on the present document should be addressed to your Regional Director of Science as indicated below:

Newfoundland/Terre-Neuve:	Larry Coady (709-772-2028)
Scotia-Fundy:	Stephen MacPhee (902-426-3492)
Gulf/Golfe:	John Loch (506-851-6257)
Québec:	Jean Boulva (418-775-0555)

### **1. Overview of Groundfish Stocks**

#### **1.1. General Overview of Commercially Exploited Groundfish**

The mortality rates of the cod, haddock, pollock and many flatfish resources on the Canadian Atlantic coast have recently reached very high values and stock sizes are currently low. Less than 50% of those fish of recruited age that are present at the beginning of a year are still alive at the end of the year. The catch depends on two or three age-groups at a young age while these species could easily live up to 20 years with many more ages contributing to the catches. The fisheries are very dependent on recruiting year-classes and the fish are harvested at a rate considerably greater than their growth rate. This means that biomass is declining steadily with no hope of sustained increase at current high mortality rates. Adult

biomasses are either the lowest observed or very close to it. In all cases the estimated fishing mortality rate is substantially higher than the target rate of  $F_{0.1}$ .

Fishing mortalities in excess of the target have been noted since at least 1987. At that time, stock sizes were high and recruitment appeared to be average or better; there was no apparent urgency to reduce fishing mortalities abruptly to  $F_{0.1}$  from one year to the next. The 50% rule was therefore introduced to gradually achieve the target of  $F_{0.1}$ . This was not successful. Fishing mortalities have continued to increase and stocks have continued to decline to reach their current historical minima.

A number of factors are responsible for the current state of the stocks. A comparison of biomass trends among cod stocks shows significant correlations ( $p < 0.05$ ) among northern stocks (2J3KL, 3Ps, 3Pn4RS, 4T-4Vn, 4VsW) which are different than the trends for southern stocks (4X and 5Zjm). Year-class survival, defined here as the abundance of a year-class when it enters the fishery divided by the spawner biomass that produced it, in the northern stocks in the mid-to-late 1980s has been considerably lower than in previous years. This implies that the mortality between the time the eggs were produced and the time the recruits enter the fishery has increased, perhaps because of ocean climatic conditions, predation, competition, disease, or fishing (discarding). As a result, there have been several below average year-classes produced in the 1980s, with only the 1987 year-class showing average or slightly above average strength. Growth rates have also been low. The geographical distribution of many fish stocks is now considerably smaller than in previous years making them more vulnerable to fishing. Finally, total mortality rates (fishing + natural) have been high and have increased in recent years as the stock biomasses have decreased.

TACs, in the vast majority of cases, have been set based on scientific assessments, but these have generally overestimated potential catches. This is partly due to methodological deficiencies, not unique to Canadian fisheries science, such as the inability to predict future weights at age and recruitment which have both been declining almost steadily over this period. However there are also serious problems with the data that have been used. It is widely accepted that misreporting, dumping and discarding have been major problems in groundfisheries from at least 1985. The severity of misreporting, dumping and discarding has probably decreased in recent years as a result of better enforcement, but it still existed in 1992 and remains unquantified. The scientific assessments are critically dependent on the accuracy of catch data. Inaccuracies in reported catches have therefore caused major problems in assessing the size of the stocks.

Fishing is not the only cause of mortality. The sudden decrease in biomass estimates from research surveys observed from one year to the next in several cod and flatfish stocks cannot be attributed entirely to fishing. Changes in migration and shrinking geographical distributions, increases in natural mortality because of harsh climatic conditions, combined with poor feeding, predation by seals and other predators or competition with them are additional possible causes of increased mortalities. Given these added causes of mortality, the remaining stocks should be given as much protection as is possible in order to take advantage of better survival conditions when they occur.

The immediate and medium term prospects are poor. Recent year-classes appear to be weak and will therefore not contribute substantially to stock rebuilding. Even if the 1992 year-classes in those stocks were to be strong, they would not make significant contributions to spawning until 1997 at the earliest. Stock rebuilding will be slow and it will depend on future recruitment which will be influenced largely by climatic

conditions. However, even if nature were to produce good recruitment, this would not lead to sustained rebuilding unless fishing mortality is decreased substantially and permanently.

Controlling catches is a necessary prerequisite to reducing fishing mortality, but it is not sufficient on its own. It is now widely accepted (for example, in the North Sea and in New Zealand) that attempting to reduce fishing mortalities only by controlling catches, without some direct control on the fishing effort exerted will be unsuccessful in fisheries with severe overcapacity problems such as those of the Canadian Atlantic coast. The Georges Bank cod and haddock fisheries are good examples of the potential to exert fishing mortality; in 1989, the mobile gear fleets fished for only one month and this was sufficient to exceed  $F_{0.1}$ . The necessary drastic reductions in fishing mortalities can only be achieved by substantially decreasing fishing effort and these reductions need to be permanent. As stocks recover, catches will increase and there will be pressure from the industry to increase fishing effort. However, these pressures will have to be resisted if the benefits of an  $F_{0.1}$  management strategy are to be realized.

Decreasing the fishing mortality however does not mean that the stocks will increase forever. There will still be variability in year-classes and stocks will still fluctuate. However, dangerously low stock sizes such as those currently estimated for our Canadian Atlantic groundfish resources will be less likely to happen.

The principal index of abundance used to paint the grim picture above comes from the research vessel surveys DFO conducts to estimate biomass. These surveys are statistically designed, similar to opinion polls or tree abundance estimation in forestry, to provide unbiased estimates. However a number of factors may influence the results of any one year quite importantly. The results are notably variable from one year to the next, with some years overestimating abundance while others underestimate it. It is therefore possible that the stocks could be higher than described in this document, although there is no question that the stocks are very low.

## **1.2. Overview of Commercially Exploited Groundfish on the Newfoundland Shelf and on the Grand Banks**

The groundfish fisheries in the waters around Newfoundland exploit three main species groups: the gadoids (mainly cod with some haddock, pollock and hake), the flatfishes (American plaice, yellowtail flounder, witch flounder, Greenland halibut and Atlantic halibut) and the others consisting of species such as redfish and grenadiers. The relative importance of the different species and stocks has varied over time, but recently cod, American plaice, yellowtail flounder, witch flounder, Greenland halibut and redfish have been the most important.

Of these, cod has historically dominated the catches. Most important has been the Div. 2J3KL or "northern" cod stock but important cod fisheries also take place on the southern Grand Banks (Div. 3NO stock) and off the south coast (Subdiv. 3Ps stock). Cod catches from all of these areas gradually declined after peaking in the 1960s. In 1976, the last year before extension of jurisdiction, catches were 6,000t from 2GH, 214,000t from 2J3KL, 24,000t from 3NO and 37,000t from 3Ps. Although some of the reduction was due to quota management through ICNAF, the declines generally reflected stock reduction because of overfishing. Since extension of jurisdiction, the trajectories of the stocks have shown both similarities and differences. The resource in Div. 2GH has almost disappeared based on recent survey estimates (1991). A number of

possible causes have been put forward to explain the dramatic decline in 2J3KL cod. Many have variously blamed the decline on the Canadian offshore trawler fleet (destroying habitat, interrupting spawning, excessive dumping and discarding), the foreign fishery outside 200 miles, gillnets, cod traps, seals and the environment. It is currently believed that all of these may have contributed, in part, to the decline. It is not possible, however, to determine the relative importance of each factor. It is also not clear when the decline took place. Evidence from various surveys and fisheries may indicate that the decline occurred during the first half of 1991, but the earlier decline in biomass in the more northern areas, in 2J and perhaps in 2GH may suggest that events began as early as the late 1980s. On the Grand Banks (Div. 3NO), the decline in recent years is thought to be due to a combination of factors. There were a number of years of poor year-classes during the mid-1980s. Beginning around 1986, total catches far exceeded TACs due to foreign catches outside 200 miles on the "tail" of the Grand Banks. The problem of overfishing is exacerbated by the fact that these foreign fisheries are taking very high numbers of small fish probably as a result of the use of undersized mesh in cod ends. In Subdiv. 3Ps, survey estimates fluctuated considerably between years but gradually increased until about 1988 (85,000t) before declining somewhat. The 1992 survey results suggested a decline to only 16,000t and the 1993 results were 12,000t and 7,800t from the February and April surveys respectively. With settlement of the boundary dispute, French catches dropped from about 16,000t in 1991 to only 7,000t in 1992. There has been no French catch to date in 1993. This stock is considered to be at a low level, primarily due to high fishing mortalities in recent years.

Of the flatfish stocks, American plaice on the Grand Banks (Div. 3LNO) is historically the most important. The 1992 biomass estimate from surveys is the lowest in the series. As with cod on the Grand Banks, foreign catches outside 200 miles have been greater than their allocations since 1986, and they have caught smaller fish than taken in the Canadian fishery. This has resulted in exploitation rates exceeding reference levels. There are however, indications that the declines in biomass in Div. 3L are greater than can be explained by the fishery alone. It is unknown if this is related to factors contributing to the decline in 2J3KL cod or not. American plaice fisheries also take place in SA2+Div. 3K, and Subdiv. 3Ps. Research vessel survey results indicate that through the 1980s, the greatest proportion of biomass was in Div. 2J where it peaked in 1983 then gradually declined thereafter. In Div. 3K, biomass was stable until about 1987 then declined. Estimates in the 1990s from both divisions continued to decline, and the 1991 and 1992 estimates were only 12,800t and 5,500t respectively. The observed declines cannot be attributed to fishing mortality alone. Similar to 2J3KL cod, non-fishery related factors are probably contributing to the observed declines, although these cannot be quantified at present. In Subdiv. 3Ps, survey estimates of trawlable biomass fluctuated through the 1980s but there has been a gradual and systematic decline since about 1989, and the two estimates from the 1993 surveys are the lowest observed. Although fishing mortality has probably been above  $F_{0.1}$  in recent years, it is not believed that catches in the range of 2,500 - 5,000t could be fully responsible for declines of about 90% (from surveys) since 1986-1988. As with other American plaice stocks around Newfoundland, it appears that non-fishery related factors may be contributing to the observed declines.

The only significant fishery for yellowtail flounder is on the Grand Banks (Div. 3LNO). After remaining stable through most of the 1980s, biomass as estimated from Canadian surveys, steadily declined and in 1992 was only about one third that estimated from the 1985 and 1986 surveys. Until fishing effort is curtailed, it is not expected that this resource will increase significantly.



Witch flounder fisheries take place in Div. 2J3KL, Div. 3NO and Subdiv. 3Ps. Biomass estimates from surveys peaked in Div. 2J in 1986 but declined during the more recent period. In Div. 3K, estimates were stable through the early 1980s (about 30,000t) but declined subsequently. The total estimated biomass in these two divisions in 1992 was only 1435t. In Div. 3L, estimates were between 6,000 - 7,000t until 1988 but declined to only 1,500t in 1992. In 1992, the stock was at the lowest level ever observed. As with other stocks in the area, current fishing effort cannot account for the observed declines in biomass. On the Grand Banks (Div. 3NO) survey estimates of biomass show considerable fluctuation over the time series, but are generally lower now than in the mid-1980s. Whether this indicates a decline in stock size, or a movement of the fish to deeper water outside the survey area is unclear. Biomass estimates from surveys in Subdiv. 3Ps have fluctuated substantially between years, but there does not appear to be any long term trend in the estimates. The fluctuations may be the result of some portion of the stock being distributed in deeper water outside the survey area. Possible impacts of the fishery cannot be determined.

It is currently believed that Greenland halibut in the northwest Atlantic (with the exception of those in the Gulf of St. Lawrence) constitute one stock extending from Davis Strait (SA0 + 1) to around the Grand Banks (SA3). Results of surveys to Div. 2GH in the late 1980s indicated that the biomass had decreased by about 50%. The biomass in Div. 2J3K also declined by about 50% between 1987 and 1990. The TAC was therefore lowered to 50,000t in 1990. The estimate from the 1991 survey was only 55,000t. The observed declines in Greenland halibut in the northern areas cannot be explained by the fisheries. It is possible that the fish have redistributed to deeper water, and they may have moved further south and outside 200 miles where they have become available to the foreign fleets. At present there are no data to suggest that this foreign fishery is being prosecuted on a separate stock, and the high catches of recent years from this fishery are cause for concern.

There are four stocks of redfish in the Newfoundland area; SA2 + 3K, Div. 3LN, Div. 3O and the newly defined Laurentian Channel stock. In SA2 + 3K, survey estimates of biomass reflect a decline in the size of the stock. Estimated biomass declined from over 100,000t in the early 1980s to only about 2,000t in 1992 in Div. 2J. In Div. 3K, the decline over the same period was from over 200,000t to only 1135t in 1992. There can be no optimistic outlook for this resource until about 9-10 years after good recruitment occurs. In Div. 3LN, much of the resource is distributed outside the 200 mile limit in both 3L and 3N. There are indications that the foreign fishery continues to be excessive, and concern exists that this stock will be rapidly depleted in a short time. Because of rough bottom in much of Div. 3O where redfish could be caught, it is difficult to carry out trawling and the fleets are restricted to shallower water where smaller fish reside. These fish are unsuitable to the Canadian processors although acceptable to the foreign fleets which fish in the area outside 200 miles. Little is known about the status of this resource. The Laurentian Channel redfish stock was recently defined based on evaluation of available data from the fisheries and research in the area. Estimates of biomass in Div. 3P have fluctuated considerably over the period of surveys, but there are no long term trends in the data. There is no evidence to suggest that fishing pressure is excessive on this stock, and the size of the resource should fluctuate in the future with recruitment levels. Because new recruitment will not reach the fishery until 1997-1998, biomass and catch rates are expected to decline until then.

In the Newfoundland area, groundfish stocks can be divided into two general groups. In the areas south of Div. 3L, they appear to be primarily responding to fishing pressure. With the possible exception of Subdiv. 3Ps American plaice, all declines can be linked to excessive fishing; either Canadian or foreign. The

status of the various resources is only changing in parallel for those stocks subjected to this pressure. Trends in other stocks appear to be independent. Of particular concern is the effort being exerted outside 200 miles on the various Grand Bank stocks. All of these are important to Canadian interests, and the current moratorium on 2J3KL cod magnifies this importance. The outlook for these stocks cannot be improved unless the excessive fishing pressure is curtailed.

In the more northern areas (Div. 3L and north), the situation is less clear. While it can be argued that fisheries have affected the resources in these areas, they alone cannot account for the observed declines that are occurring across all groundfish species. For some of these species (for example, cod) the decline may have been abrupt, but there are indications of changes taking place earlier. For example, the reduction in biomass appears to have progressed from Div. 2J (and possibly 2GH), to Div. 3K to Div. 3L. Condition factors of cod began declining in 1990. For other species, the declines seem to have been progressive through the 1980s. Survey and fishery data also indicate that many of the species are now distributed further offshore and in deeper water than previously. The reasons for this are unknown. Although the 1981 year-class of redfish was relatively strong throughout all the rest of the northwest Atlantic, this was not the case in Div. 2J3K and northern 3L.

During the 1990s, sudden declines were also observed in the capelin biomass. Offshore acoustic surveys consistently failed to detect large concentrations beginning in 1990 although information from the inshore fishery suggests that the decline in biomass may not have been as precipitous as suggested by the offshore data. The abundance of harp seals has increased, but as is noted elsewhere in this report, no clear assessment of the harp seal's impact on cod can be made at this time although it can be hypothesized that increasing harp seal abundance will have an increasing impact.

All of these observations are coincidental with a gradual cooling trend in the area through the 1980s. In 1991, the ice cover was the greatest observed in 40 years, and the cold intermediate layer (CIL) was more extensive than had been observed previously. The impact of these changes on the biota of the area is unclear, and especially uncertain are the possible impacts on species interactions (both plant and animal).

For these northern resources, it is unclear if decreased or complete cessation of fishing will result in improvements in stock status. No meaningful predictions concerning the future of these resources can be made until the processes at work are better understood.

### **1.3. Overview of Commercially Exploited Groundfish in the Gulf of St. Lawrence**

The Gulf of Saint Lawrence groundfish fishery is dominated by three species: cod north and south of the Laurentian Channel (stocks of 3Pn4RS and 4TVn [Jan.-Apr.]), redfish in the deep waters of the Laurentian Channel, and to a lesser extent, American plaice in the southern Gulf. There are smaller localized directed fisheries for Greenland halibut in the St. Lawrence estuary and western Gulf, witch along the southwest coast of Newfoundland and 4T, white hake in Northumberland Strait, and winter flounder in inshore areas. Both cod and redfish are migratory and sustain winter fisheries in the Cabot Strait area and summer fisheries within the Gulf of St. Lawrence.

The water temperature in the Gulf of St. Lawrence was substantially cooler from 1990 to 1992 than in the mid-1980s. Bottom temperature in the southern Gulf in September were warmer in the 1970s and have been cold since the early 1980s. Since 1990, cold waters coming through the Strait of Belle-Isle have occupied increasingly large areas in inshore zones of the northern Gulf. The deep Atlantic waters moving through Cabot Strait were colder (reduction from about 6° to 4° C) bringing about a cooling of the deep waters in the Gulf. Ice coverage in recent years has been much more extensive than normal. This has considerably delayed the spring fisheries for cod, both in the northern and southern Gulf.

The two cod stocks in the Gulf have fluctuated in harmony with the other "Northern stocks" (i.e. northern cod, Saint-Pierre Bank cod, and eastern Scotian Shelf cod). After a period of high abundance in the 1960s, the two stocks declined to very low levels in the mid-1970s, increased to very high level of abundance in the mid-1980s, to decline very sharply since then to the lowest levels on record. The exploitation rate on these stocks increased gradually throughout the 1980s, and has increased abruptly in the 1990s. In recent years, with the decrease in growth rate and lower abundance of larger cod, the fishery has been characterized by large catches and discards of small fish (less than 41 cm). Recruitment for the two stocks has been well below average since the mid-1980s, despite high levels of spawning biomass at that time. This means that fewer recruits are produced per unit of spawning biomass. The low recruitment, combined with slower growth has contributed to the decline in biomass of cod in the Gulf of St. Lawrence.

The redfish "stock" was recently redefined to take into consideration the migration into the Cabot Strait area in the winter. Two species comprise the stock, but the dynamics of these two species are not well understood. Gulf redfish seems closely related to Laurentian Channel redfish (3P4V). The history of the stock, and hence of the fishery, is dominated by the appearance of very large, sporadic year-classes (late 1950s, early 1970s, 1982, and now 1988). The catches of redfish have a tendency to fluctuate as these strong year-classes move through the population. The large 1982 year-class is now fully recruited to the fishery and it has allowed catches and catch rates to be very high since 1990. The next visible year-class will recruit to the fishery in 1997-1998, but as this year-class recruits, the species composition of redfish in the Gulf should shift from *Sebastes mentella* to *S. fasciatus*.

The flatfish stocks, with the exception of Greenland halibut, do not seem to show these large fluctuations. After a period a relatively high abundance in the 1960s and early 1970s, the exploited flatfish stocks declined to somewhat lower levels in the recent past but have remained relatively stable since then. The fishery for Greenland halibut was characterized by large fluctuations (5 fold differences between the lows and the high over 5 years), a consequence of highly irregular recruitment and very high exploitation that does not allow the persistence of the incoming year-class in the population.

American plaice abundance varies on a much longer time scale, and for a time, appeared to be inversely related to cod abundance. American plaice abundance is now lower than average and this fishery is plagued with a major discarding problem.

#### 1.4. Overview of Commercially Exploited Groundfish on the Scotian Shelf and on Georges Bank

The Scotian Shelf and Georges Bank groundfish fisheries are dominated by cod, haddock and pollock. In addition, important fisheries for flatfish, (plaice, yellowtail, witch and winter flounder), Atlantic halibut, redfish

and silver hake are conducted in the Region (the silver hake fishery is mostly by foreign vessels). The area can be considered as two major ecosystems, the eastern Scotian Shelf and the southwest Scotian Shelf/Georges Bank area.

Since 1970, groundfish stock abundance in these two ecosystems has increased to a peak in the mid-1980s and thereafter declined to the current historical low levels. These changes have been particularly pronounced on the eastern Scotian Shelf. This year's assessment of the 4VsW cod resource is considerably more pessimistic than last year's, with downward adjustment of the 1985-90 year-classes and estimation of the highest fishing mortalities recorded. The mature biomass which was high in 1985, by 1992 had declined to the lowest levels observed. The status of this resource is precarious and there are concerns about its long term viability if fishing mortality is not reduced.

The analysis of the Sydney Bight cod (4Vn May to December) resource focused on confirming that fish present in the area during December were of 4T origin. The definition of the management unit should be adjusted accordingly.

Present estimates of eastern Scotian Shelf haddock (4TVW) spawning biomass are lower than last year with concomitantly lower probability of average or better recruitment. The population size structure has narrowed to the point where a single year-class, the 1988 year-class, dominates the population. Fishing mortality rates on the fully exploited size ranges are presently very high and, if continued, will slow or prevent the rebuilding of spawning biomass. Year-classes after 1988 have been below average.

Flatfish resources (plaice, yellowtail and witch) while under quota management, have been under increasing pressure since the introduction of individual quotas in 1991. In 4VW, yellowtail and plaice abundance are either relatively stable or increasing while that for witch is decreasing. Atlantic halibut abundance of older fish has fallen steadily since 1988.

It is evident that for most of the eastern Shelf resources, recruitment has declined since the mid-1980s. While a reduction in spawner biomass may be partially the cause, the low survivorship of ages 1-3 cod in 4VsW since 1985 indicates that other factors are involved. Ocean climate changes may be implicated. There is considerable evidence to show that the oceanographic regime on the Shelf has changed in recent years. During 1992, sea surface temperatures were generally below normal throughout most of the year. An analysis of near-bottom temperatures suggests that the region is in a period of ocean cooling with particularly cold conditions in 4V. In this area, summer bottom temperatures have declined steadily since 1978 to reach an all time low in 1992. These climate changes have been accompanied by an increase in the abundance of capelin, a cold water species. Grey seal abundance has also increased markedly since the 1960s due to sustained high pup production. While this increase has likely had some impact on eastern Shelf populations, the extent of this cannot be determined. Suspected high discard rates in the fishery may also have decreased survivorship of ages 1-3 cod.

The cod and haddock on the southern Scotian Shelf and on Georges Banks grow faster and recruit to the fishery at an earlier age than those on the eastern Scotian Shelf. Since the early 1970s, high exploitation rates mean that fish are harvested at a young age. This makes these fisheries extremely dependent on incoming recruitment. As a result, landings have fluctuated greatly with changes in recruitment. Specifically, the 4X cod and haddock fisheries are presently dependent on only 1 or 2 year-classes, with biomass either

declining or expected to decline due to recent poor recruitment and high exploitation rates. Misreporting of catches by management unit (e.g. 5Z haddock catches reported as 4X haddock) continues to occur, though apparently to a lesser degree than in the 1980s.

The only positive sign is an indication, based on Georges Bank cod, of an above-average 1990 year-class. The Georges Bank cod and haddock stocks are severely depleted as excess fishing capacity has been channelled to those stocks when individual quotas were introduced on the Scotian Shelf in 1991. The transboundary nature of these resources has complicated management. A study of migration patterns suggests that for haddock in particular but also for cod, there would be benefits to Canada if it were to unilaterally adopt conservation measures. However, considering the presently very low stock sizes, stock rebuilding would require joint management.

The Scotian Shelf pollock has been declining as the year-classes which followed the exceptional 1979 year-class have been moderate at best. Exploitation for this species is also very high and a continued decline is forecast until better recruitment occurs.

Flatfish resources (plaice, yellowtail and witch) in 4X while under quota management have also been under increased fishing pressure since the introduction of individual quotas on the Scotian Shelf in 1991. Survey estimates indicate that witch flounder abundance is decreasing while for plaice and yellowtail, abundance is either stable or increasing slightly.

Winter flounder are currently outside the quota management system although landings in 4X are higher than for other flatfish species. Survey catch rates have increased since 1988, however being in part a coastal species, the survey only covers the offshore portion of this resource. Industry comments suggest that catch rates are declining in inshore areas. If individual quotas are introduced for flatfish, winter flounder should be included under quota management to prevent a shift of effort to non quota species or to misreport quota species. Overall the status of flatfish stocks on the Scotian Shelf cannot be assessed with present information because landings are not reported by species.

Contrary to the situation on the eastern Scotian Shelf, while recent recruitment on the southern Shelf has been low, this does not appear to be as a result of low survivorship of young fish. Sea surface and near bottom temperatures on the southern Scotian Shelf and Georges Bank were generally below normal throughout most of 1992. Also, in 1992 normal low spring salinities extended deeper into the water column and persisted longer than usual. It is not possible to relate these changes to the declines in abundance.

Overall, except for stocks such as 4X haddock, 4WW plaice and yellowtail and 4X winter flounder, all groundfish resources have declined in abundance since 1988, in some cases to historical low levels. These declines are due to a combination of recent low recruitment and high exploitation rates. Examination of stock/recruitment relationships indicates that juvenile survivorship in a number of stocks has declined in recent years, with fewer recruits being produced per unit of spawning biomass. Some of this may be due to seal predation or discarding by the commercial fishery. However, the dramatic changes in the ocean climate likely also play a large role.

### 1.5 Environmental Conditions

The Fisheries Oceanography Subcommittee reviewed the ocean climate condition in the northwest Atlantic at its March, 1993 meeting. This involved analysis of broad-scale environmental data with emphasis on atmospheric and oceanographic conditions in 1992, analysis of hydrographic conditions from each region during the 1992 groundfish surveys and comparison of environmental conditions in 1992 and the recent past.

#### *Labrador and Newfoundland*

In 1992, relatively cold conditions were observed in the waters off southern Labrador and northern Newfoundland. A cold Arctic air mass covered the region during the winter of 1991-92 which promoted early ice growth. Strong northwesterly winds pushed the ice southward so that the areal extent of ice through most of the first three months of 1992 was above normal. The offshore limits of the ice edge matched or were near their long-term maxima through much of the winter. Ice also persisted longer than normal with new records being set for the date of the presence of the last ice in the offshore regions of northern Newfoundland. Relatively high numbers of icebergs drifted south of 48° N during the spring and summer. Air temperatures continued to remain below normal throughout the year except in the late summer and early autumn. In response to the cold air, sea surface temperatures were generally below their long-term means. At Station 27, the monthly sea surface temperature anomalies were all below normal with the largest anomalies (near -2° C) occurring in July and October. Negative temperature anomalies also persisted throughout the water column at Station 27 during most of 1992. The near bottom temperatures (175 m) were below normal for the 10th consecutive year but a slight warming was observed during the year. Salinities throughout the water column at Station 27 were typically fresher than normal in 1992. The area extent of the cold intermediate layer (CIL), defined by waters of temperature <0° C, along several transects off southern Labrador and northern Newfoundland was slightly above normal but had decreased significantly from a maxima in 1990. During the annual fall groundfish survey surface temperatures and near bottom temperatures were generally below normal. The amount of water <-1° C was less in the fall of 1992 than in 1991 but was greater than the long-term mean. In general the cold air temperatures, heavy ice and cold sea temperatures observed in 1992 are similar to the previous two years and match conditions in the early 1970s and mid-1980s. These cold conditions are related to the wintertime atmospheric circulation, and specifically an intensification and/or westward shift in the strength of the Icelandic low which generates relatively strong northwesterly winds over the Labrador Sea.

#### *Gulf of St. Lawrence, Scotian Shelf and Gulf of Maine*

Colder than normal air temperatures were also present south of Newfoundland during the winter of 1991-92. In the Gulf of St. Lawrence, the timing of the ice formation was within a week of its normal occurrence but by the end of January the ice extent was greater than normal. Ice pushed onto the northeastern Scotian Shelf in February and its areal extent exceeded the long-term median. On the Scotian Shelf and in the Gulf the ice retreat was late with new records set for the last presence of ice on the Magdalen Shallows. Sea surface temperatures on the Scotian Shelf and in the Gulf of Maine point to cold water throughout most of 1992. These reflect conditions in the upper layers (50-100 m depth) based on data from Prince 5 and Emerald Basin. In Emerald Basin, lower layer (>75m) temperatures increased dramatically over near record cold conditions last year to above normal temperatures in 1992. A similar event was observed in the deep

(200-300 m) waters in Cabot Strait. These warmer waters are believed to be related to changes in the slope waters off the continental shelf which then intruded onto the shelf during late 1991 or early 1992. In contrast, in the northern Gulf of St. Lawrence, waters of Labrador origin penetrated the Strait of Belle Isle and spilled over into the Esquiman Channel. Consequently, bottom temperatures in this region dropped by approximately 2°C between 1990 and 1992. On the Magdalen Shallows, temperature data collected during the September groundfish survey revealed colder than normal bottom waters at this time in 1992. The area of the waters on the Shallows with temperatures below 0°C was much greater than normal during the past three years. Other years of extensive cold waters were 1972 and 1984. On the northeastern Scotian Shelf, near-bottom temperatures in the summer of 1992 were also colder than their long-term means and the largest volume of cold intermediate layer water was recorded in over 20 years. Salinities at this time were typically fresher than average. Colder than normal bottom temperatures in summer were also observed off Browns Bank, southwest Nova Scotia and throughout the Bay of Fundy. On Georges Bank, temperatures recorded during the spring groundfish surveys indicated near normal bottom temperatures and salinities.

#### *Offshore*

The shelf/slope front and the Gulf stream were generally northward of their long-term mean positions during 1992.

## 2. Summary Sheets

## 2.1 COD in 2J, 3K and 3L

SUMMARY

Fig. 1.1a-1.1h

Year - Année	1986	1987	1988	1989	1990	1991	1992	1993	Min. <sup>1</sup>	Med. <sup>1</sup>	Max. <sup>1</sup>
Reference level/Niveau de référence '000t	266	266	293	N/A	N/A	100-215	185	<sup>2</sup>			
TAC - TPA '000t	266	256	266	235	199	190	120				
Rep.catches-Prises décl. '000t	252	235	269	253	219 <sup>3</sup>	171 <sup>3</sup>	44 <sup>3</sup>		49	278	810
Unreported catches Prises non-déclarées											
Est.discards - Rejets est.											
Tot. catches - Prises Tot.											
Tot.biomass-Biomasse Tot.											
Sp.biomass-Biomasse Rep.											
Mean - F - Moyen											
<sup>1</sup> For/Pour 1962-1992 <sup>2</sup> June 1992 - lowest possible/juin 1992, plus bas possible. <sup>3</sup> Preliminary statistics/Statistiques provisoires											

**Forecast for 1994:** Continuing fisheries (the Canadian recreational fishery and foreign catches outside the 200 mile limit) may be factors in retarding the recovery of the stock.

**Catches:** A moratorium was imposed on the Canadian fishery in July 1992. Canadian fishing in this area was severely curtailed with about 29,000t taken in 1992. However, 14,300t of cod were also caught outside of the Canadian Economic Zone in Division 3L during the first half of the year by non-Canadian vessels.

**Data and Assessment:** The principal index of abundance is an autumn research vessel survey series. From 1978 to 1990, the catch per tow has averaged about 50 fish with the 1990 catch per tow equal to the average. The catch per tow decreased to 33 fish in 1991. The decline was more pronounced for fish age 6 and older. Despite the severe reduction in fishing activity as a result of the moratorium, the catch per tow decreased further during the 1992 autumn survey to 9 fish per tow.

**Fishing Mortality:** Total mortality is estimated to be very high, above 1 in 1991 which means that more than 60% of the fish are dying each year. Under the normal assumption of constant natural mortality ( $M=0.2$ ), this would imply very high fishing mortality. However, fishing activity has not increased in the Canadian Zone so as to explain such an increase in total mortality. The fishing mortality, however, may have increased because the fish could be substantially more catchable, perhaps because of climatic conditions. Another possible explanation is that natural mortality may have increased as a result of harsh climatic conditions, poor feeding, predation by seals or competition with them, or migration out of the area.

**Recruitment:** The 1986 and 1987 year-classes are still dominating the stock despite their being less abundant than the average for corresponding age. Based on relationships between recruitment success and hydrographic variables, it is likely that the 1988 to 1991 and probably 1992 year-classes will be weak.

**State of the Stock:** The stock is in a very depressed state, probably the lowest abundance in the 20<sup>th</sup> century.

**Environmental Factors:** Climatic and hydrographic conditions in 1991-1992 off the Newfoundland shelf have been among the worst recorded for ice coverage, duration of ice, extent of the cold intermediate layer of water less than 0° C.

**Multispecies Considerations:** Capelin abundance as estimated from acoustic surveys have been very low since 1990 in these areas and the biomass of several other groundfish stocks, some very lightly exploited have also decreased markedly during the 1980s. Following the cessation of the large vessel hunt for harp seals in 1983, the abundance of the seal herd is estimated to have increased to about 3 million seals in 1990. However, the increase is likely to have continued.

**Long-term Prospects:** Catches since 1960 have averaged about 350,000t during a period of relatively high exploitation rates. Before the expansion of the fishery in the 1960s, catches have generally been in the 200,000t to 300,000t range. Given the current state of the stock, and considering that fish are normally becoming mature at about age 7, recovery of the spawning stock biomass is unlikely before the year 2000 at the earliest.



**2.2. COD in 3Ps**  
**SUMMARY**  
 Figs. 1.2a - 1.2f

Year - Année	1986	1987	1988	1989	1990	1991	1992	1993	Min. <sup>1</sup>	Med. <sup>1</sup>	Max. <sup>1</sup>
Reference level - Niveau de référence '000t	26-61	26-58	37	20.5	N/A	29-44.5	39-44.5	20			
TAC - TPA '000t	60.6 <sup>3</sup>	60.6 <sup>3</sup>	60.6 <sup>3</sup>	50 <sup>3</sup>	45 <sup>3</sup>	44 <sup>3</sup>	44 <sup>3</sup>	20			
Rep.catches-Prises décl. '000t	57	57	43	39.5	41 <sup>2</sup>	43 <sup>2</sup>	31.5 <sup>2</sup>		27	49	84
Unreported catches Prises non-déclarées											
Est.discards - Rejets est.											
Tot. catches - Prises Tot.											
Tot.biomass-Biomasse Tot. <sup>4</sup> ( '000t)	200	168	144	141	139	111	81		80	168	293
Sp.biomass-Biomasse Rep. <sup>4</sup> ( '000t)	60	57	49	43	36	28	24		18	58	123
Mean - F - Moyen (6+) <sup>4</sup>	.55	.66	.59	.46	.58	.70	.70		.33	.54	1.16
<sup>1</sup> For/Pour 1959-1992 <sup>2</sup> Preliminary statistics/Statistiques provisoires <sup>3</sup> This is the effective TAC which was obtained by combining the Canadian quota and the French quota of the TAC set by each party/TPA "defacto" obtenu en additionnant les quotas établis par le Canada et la France <sup>4</sup> Not calibrated, for illustrative purposes/Non ajusté, calibré pour illustration											

**Forecast for 1994:** No quantitative forecast was made. Fishing mortality, and therefore fishing effort, would have to be decreased by a factor of about 3 to correspond to  $F_{0.1}$ .

**Catches:** 1992 catches were 32,000t, markedly lower than those during 1991. The decrease was partly due to the settlement of the boundary dispute because France did not fish after July 1992.

**Data and Assessment:** Canada conducted two surveys in 1993 (February and April) to ensure that the timing of the cod migration would not impact on the estimate of biomass. Results from the two surveys confirmed the low estimate from the 1992 survey. France discontinued their surveys after 1992. Based on multiplicative analyses of catch-at-age from research surveys and the commercial fishery and on average fishing mortalities from preliminary SPA, it was concluded that fishing mortality in recent years has probably been in the range of 0.5 to 0.9. An illustrative SPA using  $F=0.70$  was conducted to demonstrate stock size trends.

**Fishing Mortality:** Results from the illustrative SPA indicate that fully recruited fishing mortalities have been greater than twice  $F_{0.1}$  since the extension of jurisdiction, and have been gradually increasing since that time. Coincidentally, there has been a gradual decline in stock size through the second half of the 1980s.

**Recruitment:** The 1993 survey results indicated that the 1987 and 1989 year-classes are relatively strong.

**State of the Stock:** The stock abundance is at about its lowest since 1978.

**Environmental Factors:**

**Multispecies Considerations:**

**Long-term Prospects:** There has been a gradual decline in stock size through the second half of the 1980s. Some decrease in the rate of decline can be expected because of recruitment of the relatively strong 1987 and 1989 year-classes. However, unless there is a considerable reduction of fishing effort, longer term increases in stock size cannot be anticipated at this time.

## 2.3. COD in 3Pn and 4RS

**SUMMARY**

Fig. 1.3a - 1.3j

Year - Année	1986	1987	1988	1989	1990	1991	1992	1993	Min. <sup>1</sup>	Med. <sup>1</sup>	Max. <sup>1</sup>
Reference level - Niveau de référence '000t	83	80.3 <sup>2</sup>	73.9 <sup>2</sup>	72	56	35	24-35	35			
TAC - TPA '000t	92.1	80.3	73.9	76.5	58	35	35	31			
Rep.catches-Prises décl. '000t	83	67	48	47	40 <sup>3</sup>	32 <sup>3</sup>	29 <sup>3</sup>		29	79	106
Unreported catches Prises non-déclarées											
Est.discards - Rejets est.											
Tot. catches - Prises Tot.											
Tot.biomass-Biomasse Tot. '000t	303	210	168	162	211	188	172	193	162	303	444
Sp.biomass-Biomasse Rep. '000t	111	87	59	62	47	34	29	46	29	99	182
Mean - F - Moyen (7-9)	0.69	0.86	0.53	0.69	0.69	0.57	0.51		0.36	0.51	0.86
<sup>1</sup> For/Pour 1974-1992 <sup>2</sup> 50% rule / Règle du 50% <sup>3</sup> Preliminary statistiques/Statistiques provisoires											

**Forecast for 1994:** Fishing at  $F_{0.1} = 0.20$  in 1994 will yield catches of about 20,000t. The total biomass would increase to 210,000t and the spawning biomass to 81,000t in 1994.

**Catches:** Peaked at 106,000t in 1983 and have steadily declined to an historic low of 29,000t in 1992. Catches since 1987 have been lower than the average for the period 1964-1992 which equals 75,000t.

**Data and Assessment:** Commercial catch rates are not considered reliable indices of abundance because of contradictory trends between fleets (work to investigate this question is ongoing). Therefore the assessment is calibrated with the results of a research survey conducted in January. The results for 1993 are the second lowest in the time series. The assessment was calibrated using ADAPT in a manner very similar to last year.

**Fishing Mortality:** Is estimated to have been about  $F = 0.50$  on fully recruited ages, substantially above the target of  $F_{0.1} = 0.2$ .

**Recruitment:** The 1971 to 1983 year-classes ranged from 61 million to 196 million. Since then, with the exception of the 1987 year-class at 140 million, year-classes have ranged between 43 million and 90 million, considerably less than during the previous decade. The 1988 and 1989 year-classes are estimated to be weak although the information on their abundance is not precise.

**State of the Stock:** This cod stock is at a very low level, probably the lowest in the last 20 years.

**Environmental Factors:** The distribution of cod (based on the research survey data) moved to considerably greater depths, from 150m in 1978 to 250m in the early 1980s, and over 450m from 1991 to 1993. Bottom water temperatures have been lower than average in 1991 and 1992.

**Multispecies Considerations:** Shrimp, snow crab, lobster, herring and mackerel abundance are generally high in this area. Grey seal abundance in the Gulf of St. Lawrence is increasing albeit at a rate slower than on Sable Island. A component of the harp seal herd breeds in the Gulf of St. Lawrence.

**Long-term Prospects:** Under conditions of average productivity, cod in this area should yield in the order of 80,000t per year. Biomass is expected to increase in the near future as a result of the average 1986 and 1987 year-classes. However considering the current low abundance and weak incoming recruitment, sustained stock rebuilding is likely to be slow.

**Special Comment:** This assessment is currently entirely dependent on the research vessel survey conducted in January which could cease to be conducted after 1994. However this may be counteracted by the addition of new indices of abundance. The index fishers program started in 1990, the summer survey, and the new commercial catch rate series based on individual vessels may show some promising avenues.

## 2.4. COD in 4T and 4Vn (Jan.-Apr.)

**SUMMARY**

Figs. 1.4a - 1.4l

Year - Année	1986	1987	1988	1989	1990	1991	1992	1993	Min. <sup>1</sup>	Med. <sup>1</sup>	Max. <sup>1</sup>
Reference Level - Niveau de référence '000t	60	24	49	55	53	48-53	43	13-15			
TAC - TPA '000t	60	45	54	54	53	48	43	13			
Rep.catches-Prises décl. '000t	67.2	53.2	54.6	55.4	54.5 <sup>2</sup>	47.4 <sup>2</sup>	38.7 <sup>2</sup>		22.2	56	104.5
Unreported catches Prises non-déclarées											
Est.discards - Rejets est. '000t						3.0	2.6				
Tot. catches - Prises Tot.											
Tot.biomass-Biomasse Tot. '000t	324	279	213	196	184	153	119	102	102	279	491
Sp.biomass-Biomasse Rep. '000t	249	219	181	154	121	103	83	63	63	189	427
Mean - F - Moyen (7+)	.66	.48	.61	.84	.97	.95	.87		.28	.54	1.39
<sup>1</sup> For/Pour 1950-1992											
<sup>2</sup> Preliminary statistics/Statistiques provisoires											

**Forecast for 1994:** Fishing at  $F_{0.1} = 0.20$  in 1994 will yield catches of about 8,000t. Both the total biomass and the spawning biomass would remain stable, close to the lowest values observed.

**Catches:** Catches from 1950 to 1992 have averaged 56,000t. The 1992 catches of 38,666t (4,358t of which were taken outside of the stock area, primarily in unit area 4Vsb) were lower than the TAC because fixed gear did not catch their allocation. The average size in the catch is small and very few fish greater than 50 cm (about 20 inches) have been caught in recent years. Persistent ice during the spring of 1992 delayed the fishery until mid-May in 4T.

**Data and Assessment:** The average catch per tow during the September 1992 survey was the second lowest since 1971 when the surveys started. The 1992 survey was done using a different vessel and results were adjusted to take into account changes in vessel fishing power. The commercial catch rates for otter trawlers increased slightly in 1992. The assessment was made using Sequential Population Analyses calibrated with ADAPT as in previous years, but also using the Laurec/Shepherd hybrid and the Extended Survivor methodology (XSA).

**Fishing Mortality:** Fishing mortality varies depending on the assessment method used, but it is likely high, quite substantially above the target of  $F_{0.1} = 0.2$ .

**Recruitment:** All indices and all assessment methods used indicate that recruitment since the 1982 year-class has been below average. The 1988-1990 year-classes appear to be particularly weak, much lower than the previous smallest year-class.

**State of the Stock:** This stock is currently at its lowest observed level in recent history since about 1950. Weights-at-age remain below average and there are no signs of improving recruitment.

**Environmental Factors:** The average temperature in which cod are found during the research survey is considerably lower during the 1980s than during the 1970s. The period of low temperature also corresponds to the period during which average weights have been lower.

**Multispecies Considerations:** Snow crab, lobster, herring and mackerel have been and are probably still relatively abundant in this area.

**Long-term Prospects:** Given average conditions for recruitment and weights-at-age, this resource could produce in the order of 50,000t in the long term. Cod are first recruited to this fishery at age 3, but they make their greatest contribution to the stock at age 5 to age 7. Considering that the 1989 and 1990 year-classes appear to be weak, spawning stock biomass is not expected to recover by any significant amount until recruitment improves and the fish become mature. Recovery after 1995 is dependent on future recruitment on which there is at present no information.

**2.5. COD in 4Vs and in 4W**  
**SUMMARY**  
 Figs. 1.5a - 1.5n

Year - Année	1986	1987	1988	1989	1990	1991	1992	1993	Min. <sup>1</sup>	Med. <sup>1</sup>	Max. <sup>1</sup>
Reference level - Niveau de référence '000t	36	40	32	33.2	35	21-35	35.2	11			
TAC - TPA '000t	48	44	38	35.2	35.2	35.2	35.2	11			
Rep.catches-Prises décl. '000t	52	46	38	37	30 <sup>2,4</sup>	24 <sup>2,4</sup>	25 <sup>2,4</sup>		10	52	80
Unreported catches Prises non-déclarées											
Est.discards - Rejets est. '000t	3	3	3	3	3	3	3				
Tot. catches - Prises Tot.											
Tot.biomass-Biomasse Tot. '000t	175	136	110	101	86	67	50	37	37	151	243
Sp.biomass-Biomasse Rep. '000t	100	84	71	52	33	19	18	14	10	59	102
Mean - F - Moyen (7-9)	0.44	0.53	0.66	0.55	1.31	0.73	1.56		0.22	0.46	1.56
<sup>1</sup> Catches/Prises: 1958-1992; Biom. & F; 1970-1992 <sup>2</sup> Adjusted for 4T / Ajusté pour 4T <sup>3</sup> Discards reported to have been high but not quantified/Rejets ont été élevés mais non quantifiés <sup>4</sup> Preliminary statistics/Statistiques provisoires											

Forecast for 1994:  $F_{0.1}$  catches in 1994 are in the order 2,500t.

**Catches:** Discards are reported to have been high in some years, but they have not been quantified. Reported catches have been maintained close to the TAC partially because of the harvest of 4T-4Vn cod in 4Vsb in the winter. Historically, longlines have taken larger fish than mobile gear. In 1992, however the size composition for both gear was very similar with very few fish larger than 70cm and most of the catch in the 45 to 60 cm range. After the mobile gear closure in 4W to protect juvenile haddock came into effect, there has been a marked increase in longline catches of cod in the closed area.

**Data and Assessment:** The sequential population analysis was calibrated with the results of a spring survey (1979-1992) and a summer survey (1970-1992). The spring 1992 survey was the lowest ever with less than 200 fish taken during the entire survey. The July 1992 survey was higher than the 1991 value, but still low. The 1993 spring survey was similar to the July 1992 summer value but was not used in the calibration.

**Fishing Mortality:** Total mortality is estimated to have increased substantially over the 1980s and was above 1.0 in 1992, implying that more than 60% of the population is dying each year. With a constant natural mortality rate of  $M=0.20$ , this would mean that fishing mortality is substantially above the  $F_{0.1}=0.20$  target. A shrinking of the distribution may have increased catchability and fishing mortality per unit of fishing effort.

**Recruitment:** Has been substantially below average since 1984. The 1988 to 1991 year-classes, according to preliminary estimates are small.

**State of the Stock:** The spawning stock biomass and fishable biomass are at the lowest levels seen since 1970. However, small fish are still seen in the surveys. If the 1993 TAC of 11,000t is taken the spawning stock biomass will continue to decline. At such low biomasses and given the recent poor survivorship of juveniles, any recovery will be slow.

**Environmental Factors:** Bottom water temperatures have decreased markedly since the early 1980s, particularly in 4Vs, somewhat in parallel with decrease in recruitment, although no causal effect has been demonstrated.

**Multispecies Considerations:** Grey seal population abundance has increased steadily since the early 1960s and pup production has been increasing since the early 1960s at about 12% per year. Although it is not presently possible to quantify the effects of grey seals on cod, they are certain to exist either directly by predation or indirectly by competition. Grey seal stomach analysis from this and other areas show that cod can be an important food item, with the largest proportion in the stomach being less than 30cm.

**Long-term Prospects:** Cod in this area are first caught at about age 3, but they do not become mature until about age 6. This means that even if the 1992 year-class were to be strong, it would not result in a spawning stock increase until 1998. Stock rebuilding will therefore be slow.

**2.6. COD in 4X**  
**SUMMARY**  
 Figs. 1.6a - 1.6g

Year - Année	1986	1987	1988	1989	1990	1991	1992	1993	Min. <sup>1</sup>	Med. <sup>1</sup>	Max. <sup>1</sup>
Reference level - Niveau de référence '000t		13	9	12.5	12	20	20	26			
TAC - TPA '000t	20	17.5	14	12.5	22	26	26	26			
Rep.catches-Prises décl. '000t	20	19	20	20	24 <sup>2</sup>	26 <sup>2</sup>	26 <sup>2</sup>		12.2	21.2	35.5
Unreported catches Prises non-déclarées											
Est.discards - Rejets est.											
Tot. catches - Prises Tot.											
Tot.biomass-Biomasse Tot. '000t	58	65	77	80	87	83	74	68	58	80	113
Sp.biomass-Biomasse Rep. '000t	46	42	53	58	75	68	56	50	42	62	95
Mean - F - Moyen (4-6)	0.55	0.49	0.58	0.40	0.45	0.48	0.60		0.27	0.45	0.76
<sup>1</sup> For/Pour 1948-1992. <sup>2</sup> Preliminary statistics/Statistiques provisoires											

**Forecast for 1994:** If the TAC of 26,000t in 1993 is taken,  $F_{0.1}$  catches in 1994 would be about 7,000t.

**Catches:** Catches have been irregularly cyclical since 1960 with peaks in 1968, 1982 and 1991. They have averaged about 20,000t over this period.

**Data and Assessment:** The assessment was done using sequential population analyses calibrated with ADAPT using the results of a July research vessel survey. The 1992 survey biomass was 10% lower than in 1991.

**Fishing Mortality:**  $F$  has been consistently above twice  $F_{0.1}$  and has been increasing since 1989.

**Recruitment:** The strong 1985 and 1987 year-classes have made most of their contribution to catches. Other year-classes during the 1980s were generally below average. Incoming year-classes were assumed to be average.

**State of the Stock:** This stock is rapidly declining from very high abundance in 1990. Although stock biomass shows distinct irregular cycles, there is a general downward trend.

**Environmental Factors:**

**Multispecies Considerations:**

**Long-term Prospects:** Catches since 1948 have averaged about 20,000t, but the average for 1960 to 1992 was higher. Decreasing maxima in biomasses may be indicative of decreasing productivity, perhaps because of continued high exploitation. Yield has been foregone due to high fishing mortalities which do not permit the growth potential to be realized. The fluctuations in biomass and catch could be dampened by reducing exploitation rates and allowing each year-class to contribute to the fishery for a greater duration. This would make the fishery less susceptible to recruitment variations.

## 2.7. COD in 5Zj and in 5Zm

SUMMARY

Figs. 1.7a - 1.7b

Year - Année	1986	1987	1988	1989	1990	1991	1992	1993	Min. <sup>1</sup>	Med. <sup>1</sup>	Max. <sup>1</sup>
Reference level - Niveau de référence '000t	11	12.5	9.9	8	8	11-22	15-22	14			
TAC - TPA '000t	11 <sup>2</sup>	12.5 <sup>2</sup>	12.5 <sup>2</sup>	8 <sup>2</sup>	-	15 <sup>3</sup>	15 <sup>3</sup>	15 <sup>3</sup>			
Rep.catches-Prises décl. '000t	14	17	21	14	21 <sup>4</sup>	20 <sup>4</sup>	17 <sup>4</sup>		12	17	26
Unreported catches Prises non-déclarées											
Est.discards - Rejets est.											
Tot. catches - Prises Tot.											
Tot.biomass-Biomasse Tot. (1+) '000t	63	71	72	64	68	57	41	29	29	62	75
Sp.biomass-Biomasse Rep. (3+) '000t	40	37	54	48	58	39	25	25	25	43	58
Mean - F - Moyen (3+)	.49	.42	.50	.34	.52	.78	.86		.34	.48	.86

<sup>1</sup> For 1978-1992 / Pour 1978-1992  
<sup>2</sup> Canadian allocation / Allocation canadienne  
<sup>3</sup> Canadian quota in the new management unit / Contingent canadien pour la nouvelle unité de gestion  
<sup>4</sup> Preliminary statistics/Statistiques provisoires

**Forecast for 1994:** All indications are that this stock has declined substantially since 1990 and that further reductions are expected if fishing continues at the present level. Given the indications that the 1991 and 1992 year-classes are well below average abundance, a catch equal to that of 1992 could result in a very high exploitation rate of the 1990 year-class (over four times the  $F_{0.1}$  reference). This year-class will have to support both the 1993 and 1994 fisheries.  $F_{0.1}$  catches in 1994 would be less than 2,000t.

**Catches:** Landings in 1992 were the lowest since 1987 for the USA while Canadian landings decreased by 2,000t compared with 1991. The 1992 landings were 16,792t, equal to the long term average of 17,000t. Canadian landings account for about 65% of the total. Canadian landings to the end March, 1993 were about 2,000t.

**Data and Assessment:** The 1993 Canadian survey shows a continuing decline and USA spring surveys also show a decline in 1992 to the lowest observed. The USA autumn survey estimate, while increasing slightly in 1992, is very low compared with other values in the series. Canadian commercial catch rates show a substantial decline since 1987.

**Fishing Mortality:** Exploitation rates were above twice  $F_{0.1}$  during 1978-1990 and about four times  $F_{0.1}$  in 1991-1992.

**Recruitment:** Preliminary estimates of the 1991 and 1992 year-classes based on research vessel surveys appear below average.

**State of the Stock:** Total and spawning biomasses are the lowest observed in the time series which begins in 1978.

**Environmental Factors:** No abnormal water temperature conditions or long term trends have been noted on Georges Bank.

#### Multispecies Considerations:

**Long-term Prospects:** Sustained stock rebuilding will probably require consistent management by the USA and Canada. Because of the rapid growth rate of this cod stock, if good recruitment occurs and exploitation is reduced, the biomass could increase quickly.

## 2.8. HADDOCK in 4T, 4V and in 4W

**SUMMARY**

Figs. 1.8a - 1.8h

Year - Année	1986	1987	1988	1989	1990	1991	1992	1993	Min. <sup>1</sup>	Med. <sup>1</sup>	Max. <sup>1</sup>
Reference level - Niveau de référence '000t	17	<sup>2</sup>	4.5	6.7	6	<sup>2</sup>	<sup>2</sup>	4-6			
TAC - TPA '000t	17	<sup>3</sup>	<sup>3</sup>	6.9	6	<sup>3</sup>	<sup>3</sup>	<sup>3</sup>			
Rep.catches-Prises décl. '000t	16.9	3.9	4.5	9.1	<sup>4</sup>	5.4 <sup>4</sup>	6 <sup>4</sup>		1.4	11.7	56
Unreported catches Prises non-déclarées											
Est.discards - Rejets est.											
Tot. catches - Prises Tot.											
Ab. #/t (RV/NR) ('000 t)	50.5	30.9	56.2	41.6	42.4	63	28.6		3	38	85
Sp.biomass-Biomasse Rep.											
Mean - F - Moyen											
<sup>1</sup> For/Pour 1954-1992, except/sauf #/t, 1970-1992 <sup>2</sup> 1987 lowest possible, 1991-1992 by-catch only / 1987 plus bas possible, 1991-1992 captures accessoires <sup>3</sup> No TAC, by-catch only / Pas de TPA, captures accessoires seulement <sup>4</sup> Preliminary statistics/Statistiques provisoires											

**Forecast for 1994:** No quantitative catch forecast was calculated.

**Catches:** Landings averaged 26,500t per year from 1950 to 1969. The average was lower from 1970 to 1979 at 5,000t. Landings ranged between 8,000t and 20,000t from 1980 to 1987. Since 1987, landings have been coming exclusively from by-catches in other groundfish fisheries. The 1992 total was about 6,000t.

**Data and Assessment:** The results of both the summer and spring surveys indicate that haddock abundance is decreasing. The bulk of the stock is concentrated in Division 4W and is mainly comprised of the 1988 year-class.

**Fishing Mortality:** Total mortality is believed to have been high in recent years. If natural mortality is  $M=0.20$ , this would mean that fishing mortality is substantially above the  $F_{0.1}=0.25$  target probably in the order of 1.0.

**Recruitment:** There are no indications of strong year-classes after that of 1988.

**State of the Stock:** The stock has essentially disappeared from 4Vn and 4Vs. In 4W, summer survey estimates in 1992 are lower than those for 1991.

**Environmental Factors:** Bottom water temperatures in large portions of the traditional stock area (4V) have been too cold for haddock in recent years. These may have either caused mortality or migration. By restricting the distribution of haddock and therefore concentrating the stock, water temperature may increase the efficiency of fishing where haddock concentrations are located.

**Multispecies Considerations:** Although it is not presently possible to quantify the effects of grey seals on haddock, they do not appear to be an important item in the diet of grey seals.

**Long-term Prospects:** Current stock sizes are much lower than those that produced average catches greater than 25,000t for the period 1950 to 1969. It is not possible to say if and when the stock can rebuild to such levels. However it is certain that current high exploitation rates will not allow such rebuilding. Reducing exploitation on the 1988 year-class will allow for a more rapid rebuilding of spawning stock biomass and increased potential for stronger recruitment.

**2.9. HADDOCK in 4X**  
**SUMMARY**  
 Figs. 1.9a - 1.9h

Year - Année	1986	1987	1988	1989	1990	1991	1992	1993	Min. <sup>1</sup>	Med. <sup>1</sup>	Max. <sup>1</sup>
Reference level - Niveau de référence '000t	12	12.3	8.2	<4.6	4.6	<sup>2</sup>	<sup>2</sup>	3			
TAC - TPA '000t	15	15	12.4	4.6	4.6	<sup>2</sup>	<sup>2</sup>	6			
Rep.catches-Prises décl. '000t	15	13.6	11	6.7	7.3 <sup>3</sup>	9.7 <sup>3</sup>	10.4 <sup>3</sup>		6.7	18.5	35.9
Unreported catches Prises non-déclarées											
Est.discards - Rejets est.											
Tot. catches - Prises Tot.											
Tot.biomass-Biomasse Tot.											
Sp.biomass-Biomasse Rep. (Female) '000t (RV/NR)	17	12	9	10	15	16			9	17	31
Mean - F - Moyen											

<sup>1</sup> Catches/Prises: 1948-1992; Biomass/Biomasse: 1970-1992.  
<sup>2</sup> By-catch / Captures accessoires  
<sup>3</sup> Preliminary statistics/Statistiques provisoires

**Forecast for 1994:** Catches equal to the 1993 TAC of 6,000t will likely result in a reduction in fishing mortality. Catches of about 6,000t in 1994 would permit a greater contribution to spawning by the 1987-1988 year-classes.

**Catches:** Long term reported landings since 1930 have averaged about 20,000t, and exceeded 30,000t during the 1960s and early 1980s. Landings have been lower than average since 1984, but they have increased recently reaching 10,000t under a "by-catch" fishery.

**Data and Assessment:** Commercial catch rates for both longliners and druggers have increased somewhat in recent years. Survey indices of abundance have generally increased from 1989 to 1991, but the 1992 value is lower than 1991.

**Fishing Mortality:** Fishing mortalities for fish at length for 40, 50, and 60 cm were estimated to have been high (0.5-1.0) throughout the 1980s but have decreased to 1992 (0.25 to 0.50).

**Recruitment:** Has been average or smaller since 1983. The survey results suggest that the 1991 year-class may also be below average.

**State of the Stock:** Stock abundance is higher than the low values of the mid-1980s, but it remains below the productive levels of the 1960s and early 1980s.

**Environmental Factors:**

**Multispecies Considerations:**

**Long-term Prospects:** The 1987 and 1988 year-classes were close to average, but all year-classes since are lower than average. Stock rebuilding is unlikely in the absence of large year-classes.



## 2.10. HADDOCK In 5Zj and In 5Zm

## SUMMARY

Figs. 1.10a - 1.10e

Year - Année	1986	1987	1988	1989	1990	1991	1992	1993	Min. <sup>1</sup>	Med. <sup>1</sup>	Max. <sup>1</sup>
Reference level - Niveau de référence '000t	4.3 <sup>5</sup>	8.3 <sup>5</sup>	8.3 <sup>5</sup>	8.1 <sup>5</sup>	3 <sup>6</sup>	5.4	5	3.5-4			
TAC - TPA '000t	5.1 <sup>4</sup>	8.3 <sup>4</sup>	8.3 <sup>4</sup>	8.3 <sup>4</sup>	NA/ND	5 <sup>2</sup>	5 <sup>2</sup>	5 <sup>2</sup>			
Rep.catches-Prises décl. '000t	5.6	6.1	5.7	3.8	4.5 <sup>3</sup>	6.4 <sup>3</sup>	5.7 <sup>3</sup>		2.4	5.9	25.0
Unreported catches Prises non-déclarées											
Est.discards - Rejets est.											
Tot. catches - Prises Tot.											
Tot.biomass-Biomasse Tot. (000t)	21.5	19.7	18.8	16.5	17.0	15.3	11.8	13.9	7.5	19.7	57.7
Sp.biomass-Biomasse Rep. ('000t)	16.5	13.1	14.4	9.9	15.6	12.6	8.5	4.3	2.2	12.6	42.6
Mean - F - Moyen (4+)	0.33	0.43	0.46	0.32	0.47	0.6	1.29		0.18	0.38	1.29
<sup>1</sup> For/Pour 1969-1992 <sup>2</sup> Canadian quota for the current management unit/Contingent canadien pour l'unité de gestion actuelle <sup>3</sup> Preliminary statistics/Statistiques provisoires <sup>4</sup> Canadian allocations for the management unit used prior to 1990/Allocations canadiennes pour l'unité de gestion avant 1990 <sup>5</sup> For/Pour 5Z <sup>6</sup> Canada only/Canada seulement											

**Forecast for 1994:** The current Canadian allocation of 5,000t for 1993 will result in fishing mortalities greatly exceeding twice the  $F_{0.1} = 0.25$  value.  $F_{0.1}$  catches in 1994 would be about 2,000t, but would be comprised almost entirely (70%) of the incoming 1992 year-class. It is too early to reliably estimate the strength of the 1992 year-class.

**Catches:** The 1992 landings by Canada declined to 4,000t with a substantial shortfall in the mobile gear allocation which is an indication of low abundance. Although catches during January and February 1993 (when haddock are in spawning aggregations) were good, catches in June 1993 following the spawning closure period were generally poor.

**Data and Assessment:** An assessment of yield per recruit for this transboundary resource concluded that the types of benefits expected from fishing at  $F_{0.1}$  (higher catch rates, higher biomasses, and larger fish sizes) could accrue to Canada from unilateral Canadian conservation actions. Yield for Canada and the Canadian  $F_{0.1}$  exploitation rate are not affected much by USA actions because the stock is largely distributed in Canadian waters and migration is limited.

The assessment of the status of the stock was done using sequential population analysis calibrated with ADAPT using the results from the Canadian spring survey and the USA spring and fall surveys.

**Fishing Mortality:** Has been higher than twice  $F_{0.1}$  in recent years and increased markedly in 1992 to the highest level, corresponding to a harvest rate of roughly 60% to 70%.

**Recruitment:** Recent recruitment has been poor, with occasional moderate-sized year-classes being produced. Early indications for the 1992 year-class suggest a moderate strength comparable to those of 1983, 1985, and 1987.

**State of the Stock:** The stock is near the historically low levels which occurred in the mid-1970s. It is a small fraction of the previous average stock sizes from 1920 to the 1960s.

**Environmental Factors:**

**Multispecies Considerations:**

**Long-term Prospects:** Rebuilding of this stock to its long term average will not be possible unless the exploitation rate is decreased substantially. In the absence of a substantial standing stock, catches will fluctuate due to their dependence on variable recruitment. Heavy harvesting of incoming year-classes as soon as they recruit to the fishery will not permit realization of their full growth potential resulting in lost yield. The stock is mostly distributed in Canadian waters with limited migration. Therefore, unilateral Canadian conservation efforts could be effective in managing a healthy stock. However, because the stock is presently severely depleted, consistent restrictive measures by both Canada and USA would enhance the chances of accelerating recovery and restoring the stock biomass.

**2.11. POLLOCK in 4V, 4W, 4X and in 5Zc**  
**SUMMARY**  
 Fig. 1.11a - 1.11h

Year - Année	1986	1987	1988	1989	1990	1991	1992	1993	Min. <sup>1</sup>	Med. <sup>1</sup>	Max. <sup>1</sup>
Reference level - Niveau de référence '000t	43	30	42	42.5	38	43	43	35			
TAC - TPA '000t	40 <sup>2</sup>	43 <sup>2</sup>	43 <sup>2</sup>	43 <sup>2</sup>	43	43	43	35			
Rep.catches-Prises décl. '000t	44	46	43	43	37 <sup>3</sup>	39 <sup>3</sup>	34 <sup>3</sup>		26	37	46
Unreported catches Prises non-déclarées											
Est.discards - Rejets est.											
Tot. catches - Prises Tot.											
Tot.biomass-Biomasse Tot. '000t	179	167	174	155	143	148	148		98	148	208
Sp.biomass-Biomasse Rep. '000t	154	136	124	120	102	96	99		58	104	160
Mean - F - Moyen (7-9)	.57	.69	.61	.56	.61	.71	.55		0.25	0.60	0.87

<sup>1</sup> For/Pour  
<sup>2</sup> Before 1990 Canadian allocation / Avant 1990, allocation canadienne  
<sup>3</sup> Preliminary statistics/Statistiques provisoires

**Forecast for 1994:** Fishing at  $F_{0.1}$  would imply catches of about 20,000t in 1994.

**Catches:** Decreased from 39,000t in 1991 to 34,000t in 1992, continuing a generally decreasing trend since 1987. The decrease in catches is more pronounced in 4VW than in 4X+5Zc and catches have become more concentrated during May-August.

**Data and Assessment:** The assessment is made using Sequential Population Analysis calibrated with the summer research vessel survey results. Survey population estimates have decreased substantially from the high value observed in 1990. The survey shows strong year to year variability, making it difficult to estimate abundance.

**Fishing Mortality:** Fishing mortality has been about  $F=0.60$  on fully recruited ages, twice the  $F_{0.1}=0.30$  target.

**Recruitment:** Recruitment has averaged 28 million since 1974. The 1989 year-class appears to be above average.

**State of the Stock:** Pollock abundance is currently lower than average and it is expected to continue to decrease.

**Environmental Factors:**

**Multispecies Considerations:**

**Long-term Prospects:** The average productivity of pollock in this area since 1974 has been 37,000t, with catches in the 1980s being generally higher than average as a result of the strong 1979 year-class. If fishing mortality remains high, the 1989 year-class, which may be above average, will not contribute substantially to spawning stock increases.

## 2.12. REDFISH in 4R,4S,4T,3Pn(J.-M.) and in 4Vn(J.-M.)

**SUMMARY**

Figs. 1.12a - 1.12d

Year - Année	1986	1987	1988	1989	1990	1991	1992	1993	Min. <sup>1</sup>	Med. <sup>1</sup>	Max. <sup>1</sup>
Reference level - Niveau de référence '000t							67	60			
TAC - TPA '000t							New Management Unit / Nouvelle Unité de Gestion				
							67	60			
Rep.catches-Prises décl. '000t	36	43.5	52	52.5	60 <sup>2</sup>	59.5 <sup>2</sup>	77 <sup>2</sup>		7.1	44	136
Unreported catches Prises non-déclarées											
Est.discards - Rejets est.											
Tot. catches - Prises Tot.											
Tot.biomass-Biomasse Tot.											
Sp.biomass-Biomasse Rep.											
Mean - F - Moyen											
<sup>1</sup> For/Pour 1959-1992 <sup>2</sup> Preliminary statistics/Statistiques provisoires											

**Forecast for 1994:** No quantitative forecast was made. Recent catches are expected to result in rapid decline in abundance.

**Catches:** Catches have increased substantially in 1992, exceeding the TAC suggested for the new management unit by 10,000t.

**Data and Assessment:** Commercial catch per unit of effort and research vessel surveys are used as indices of abundance. The commercial CPUE increased about 20% from 1991 to 1992. The research surveys suggest either stability or a decline in abundance.

**Fishing Mortality:** No quantitative estimate available.

**Recruitment:** The 1988 year-class still appears strong, but it may be weaker than previously estimated. It will start to contribute to the fishery in 3-4 years.

**State of the Stock:** The stock is still quite abundant but it is expected to continue to decrease as a result of fishing and natural mortality until the 1988 year-class reaches maturity and is recruited to the fishery.

**Environmental Factors:**

**Multispecies Considerations:**

**Long-term Prospects:** Redfish stocks are noted for recruitment occurring only periodically. This leads to wide fluctuations in stock abundance. Given that the incidence of strong year-classes is infrequent and that growth rates are very low, fishing mortalities on redfish stocks must be maintained at low levels.

**2.13. AMERICAN PLAICE in Subarea 2 and in 3K  
SUMMARY**

Figs. 1.13a - 1.13d

Year - Année	1986	1987	1988	1989	1990	1991	1992	1993	Min. <sup>1</sup>	Med. <sup>1</sup>	Max. <sup>1</sup>
Reference level - Niveau de référence '000t	10	10	10	10	10	10	10	5			
TAC - TPA '000t	10	10	10	10	10	10	10	5			
Rep.catches-Prises décl. '000t	3	1.1	1	4.2	1.8 <sup>2</sup>	.5 <sup>2</sup>	.2 <sup>2</sup>		.1	3.6	12.7
Unreported catches Prises non-déclarées											
Est.discards - Rejets est.											
Tot. catches - Prises Tot.											
Tot.biomass-Biomasse Tot.											
Sp.biomass-Biomasse Rep.											
Mean - F - Moyen											
<sup>1</sup> For/Pour 1963-1992 <sup>2</sup> Preliminary statistics/Statistiques provisoires											

**Forecast for 1994:** No quantitative forecast is possible. However stock size is very low.

**Catches:** Catches in the last two years are the lowest in the time series. The low 1992 catches may be due, in part, to low fishing activity as a result of the cod moratorium.

**Data and Assessment:** Research vessel survey results are used as indices of abundance. They show a steep decline in biomass from the late 1980s to the present, despite low commercial catches.

**Fishing Mortality:** Total mortality is likely very high in order to have caused such a rapid decrease in abundance. However, reported catches cannot explain such a rapid decrease. Misreporting of catches and migration are thought to be unlikely causes.

**Recruitment:** Research surveys indicate a decline in recent years.

**State of the Stock:** This stock had declined to very low abundance by the end of 1992. The current TAC of 5,000t is about equal to the total biomass estimate from the 1992 survey. This means that if the TAC were to be caught, it would result in very high fishing mortalities on a stock which is at an extremely low level.

**Environmental Factors:** Extreme oceanographic conditions may have increased natural mortality by an unknown mechanism.

**Multispecies Considerations:**

**Long-term Prospects:** The prospects for rebuilding in the long term are unknown. There is no sign of good recruitment. Considering that plaice ages 9-12 comprise the majority of commercial catches, a recovery of the fishery is unlikely before at least 10 years. Both the total and the spawning stock biomasses are far below any previous estimate in the 15-year time series.

## 2.14. AMERICAN PLAICE in 3Ps

SUMMARY

Figs. 1.14a - 1.14f

Year - Année	1986	1987	1988	1989	1990	1991	1992	1993	Min. <sup>1</sup>	Med. <sup>1</sup>	Max. <sup>1</sup>
Reference level - Niveau de référence '000t	5	5	5	5	4	4	3	3			
TAC - TPA '000t	5	5	5	5	4	4	4	3			
Rep.catches-Prises décl. '000t	5.1	5.3	4.4	4	4.8 <sup>2</sup>	4.4 <sup>2</sup>	2.3 <sup>2</sup>		.8	4.2	14.8
Unreported catches Prises non-déclarées											
Est.discards - Rejets est.											
Tot. catches - Prises Tot.											
Tot.biomass-Biomasse Tot.											
Sp.biomass-Biomasse Rep.											
Mean - F - Moyen											
<sup>1</sup> For/Pour 1960-1992. <sup>2</sup> Preliminary statistics/Statistiques provisoires											

**Forecast for 1994:** In the short term, fisheries can expect a continued down-turn, with no immediate prospects for stock rebuilding.

**Catches:** The Canadian inshore catch in 1992 declined to the lowest value since 1985. The catch by Canadian offshore trawlers in 1992 was the lowest since 1983, at about half the 1990 and 1991 values. The total 1992 catch was 2,300t, a 50% decrease compared with the average of the last 6 years.

**Data and Assessment:** The commercial catch per unit of effort decreased sharply in 1991 and 1992 to the lowest levels observed. Research surveys biomass estimates were relatively stable around 30,000t in 1986-1988, the 1989 estimate was 17,000t and 4 of the 5 surveys since have estimated the biomass at less than 7,000t. The two surveys conducted in 1993 gave biomasses less than 5,000t.

**Fishing Mortality:** Total mortality is likely very high in order to have caused such a rapid decrease in abundance. Although recent catches have likely exceeded  $F_{0.1}$ , it is unlikely that reported catches are solely responsible for the observed decline in abundance. Misreporting of catches and migration are thought to be unlikely causes.

**Recruitment:** Recruitment is very low according to the surveys.

**State of the Stock:** Similar to other American plaice stocks in the Newfoundland and Labrador area, 3Ps plaice has declined markedly since the mid-to-late 1980s and is now below any previously observed value. The TAC of 3000t is in the range of the total biomass estimate from the 1993 survey. If caught, the TAC would result in a very high fishing mortality on a stock that is at an extremely low level.

**Environmental Factors:** Oceanographic conditions in 1985 may have concentrated plaice, resulting in higher catchabilities to the commercial fishery and to the surveys.

**Multispecies Considerations:**

**Long-term Prospects:** The prospects for rebuilding in the long term are unknown. Both the total and the spawning stock biomasses are far below any previous estimate in the 15 years time series. There is no sign of good recruitment.

**2.15. AMERICAN PLAICE In 4T**  
**SUMMARY**  
 Figs. 1.15a - 1.15b

Year - Année	1986	1987	1988	1989	1990	1991	1992	1993	Min. <sup>1</sup>	Med. <sup>1</sup>	Max. <sup>1</sup>
Reference level/Niveau de référence '000t	10	10	10	8	10	10	10	10			
TAC - TPA '000t	10	10	10	10	10	10	10	5			
Rep.catches-Prises décl. '000t	7.2	8	7	5.7	5.6 <sup>2</sup>	5.2 <sup>2</sup>	5.1 <sup>2</sup>		5.1	8.5	11.8
Unreported catches Prises non-déclarées											
Est.discards - Rejets est.						3.2	3.3				
Tot. catches - Prises Tot.						8.2	8.3				
Tot.biomass-Biomasse Tot. (RV/NR) '000t	94	76	87	63	81	106	65		63	150	338
Sp.biomass-Biomasse Rep.											
Mean - F - Moyen											
<sup>1</sup> Catches/Prises: 1965-1992; Biom: 1970-1992. <sup>2</sup> Preliminary statistics/Statistiques provisoires											

**Forecast for 1994:** Quantitative forecast is not possible, but landings are expected to remain stable or decrease.

**Catches:** Past total catches are not known because of substantial discarding. Landings have consistently been lower than the TAC except in 1979. Landings have decreased steadily since the mid-1980s.

**Data and Assessment:** The results of a September groundfish survey are used as an index of abundance. They have also been used to estimate total mortality trends, biomass trends and year-class trends.

**Fishing Mortality:** Recent total mortality estimated from the survey is 0.54. Assuming  $M=0.20$ , this implies a fishing mortality of  $F=0.34$ , between  $F_{0.1}$  and twice  $F_{0.1}$ .

**Recruitment:** Recruitment appears to have decreased from 1972 to 1981 but has increased since, although recent estimates are not precise.

**State of the Stock:** The stock is currently much lower than in the mid-1970s. Recruitment appears to have been increasing since 1982.

**Environmental Factors:**

**Multispecies Considerations:** Snow crab, lobster, herring and mackerel have been and probably still are abundant in this area.

**Long-term Prospects:** Yield from this plaice resource could be increased substantially if discarded plaice were not caught and were allowed to grow until they reach an appropriate commercial size.

**2.16. AMERICAN PLAICE in 4V and in 4W**  
**SUMMARY**  
 Figs. 1.16a - 1.16c

Year - Année	1986	1987	1988	1989	1990	1991	1992	1993	Min. <sup>1</sup>	Med. <sup>1</sup>	Max. <sup>1</sup>							
Reference level/Niveau de référence	<div style="border: 1px solid black; padding: 5px; width: fit-content; margin: 0 auto;">           New Management Unit / Nouvelle Unité de Gestion         </div>																	
TAC - TPA																		
Rep.catches-Prises décl. '000t																.4 <sup>2,3</sup>	.5 <sup>2,3</sup>	
Unreported catches Prises non-déclarées																		
Est.discards - Rejets est.																		
Tot. catches - Prises Tot.																		
Tot.biomass-Biomasse Tot.																		
Sp.biomass-Biomasse Rep.																		
Mean - F - Moyen																		
<sup>1</sup> For/Pour <sup>2</sup> Prior to 1991, species identification is unreliable / Avant 1991, l'identification spécifique n'est pas fiable. <sup>3</sup> Preliminary statistics/Statistiques provisoires																		

**Forecast for 1994:** Assuming that the exploitation rate remains stable, catches are expected to also remain stable.

**Catches:** Landings data are not reliable because plaice are reported as unspecified flounder.

**Data and Assessment:** Estimates from summer and spring surveys are used as indices of abundance.

**Fishing Mortality:**

**Recruitment:**

**State of the Stock:** The index of abundance from the summer research surveys has recently been increasing except in 1992. The index from the spring surveys has been declining since 1990.

**Environmental Factors:**

**Multispecies Considerations:**

**Long-term Prospects:**

**2.17. AMERICAN PLAICE in 4X  
SUMMARY  
Figs. 1.17a - 1.17b**

Year - Année	1986	1987	1988	1989	1990	1991	1992	1993	Min. <sup>1</sup>	Med. <sup>1</sup>	Max. <sup>1</sup>								
Reference level/Niveau de référence	<div style="border: 1px solid black; padding: 5px; width: fit-content; margin: 0 auto;">           New Management Unit / Nouvelle Unité de Gestion         </div>																		
TAC - TPA																			
Rep.catches-Prises décl. '000t															1.0 <sup>2,3</sup>	.4 <sup>2,3</sup>			
Unreported catches Prises non-déclarées																			
Est.discards - Rejets est.																			
Tot. catches - Prises Tot.																			
Tot.biomass-Biomasse Tot.																			
Sp.biomass-Biomasse Rep.																			
Mean - F - Moyen																			
<sup>1</sup> For/Pour <sup>2</sup> Prior to 1991, species identification is unreliable / Avant 1991, l'identification spécifique n'est pas fiable. <sup>3</sup> Preliminary statistics/Statistiques provisoires																			

**Forecast for 1994:** Assuming that the exploitation rate remains stable, catches are also expected to remain stable.

**Catches:** Landings data are not reliable because plaice were reported as unspecified flounder.

**Data and Assessment:** Estimates from summer and spring surveys are used as indices of abundance.

**Fishing Mortality:**

**Recruitment:**

**State of the Stock:** Abundance estimates from the summer surveys have increased in the last two years.

**Environmental Factors:**

**Multispecies Considerations:**

**Long-term Prospects:**



## 2.18. Witch 2J, 3K, and In 3L

**SUMMARY**

Figs. 1.18a - 1.18c

Year - Année	1986	1987	1988	1989	1990	1991	1992	1993	Min. <sup>1</sup>	Med. <sup>1</sup>	Max. <sup>1</sup>
Reference level/Niveau de référence '000t	8	4	4	4	4	4	4	4			
TAC - TPA '000t	8	6	5	5	4	4	4	4			
Rep.catches-Prises décl. '000t	3.9	4.5	4.2	4.9	3.6 <sup>2</sup>	4 <sup>2</sup>	2.3 <sup>2</sup>		.9	4	24
Unreported catches Prises non-déclarées											
Est.discards - Rejets est.											
Tot. catches - Prises Tot.											
Tot.biomass-Biomasse Tot.											
Sp.biomass-Biomasse Rep.											
Mean - F - Moyen											
<sup>1</sup> For/Pour 1963-1992 <sup>2</sup> Preliminary statistics/Statistiques provisoires											

**Forecast for 1994:** No quantitative forecast possible.

**Catches:** Catches fluctuated between 3,000t and 4,500t from 1980 to 1991. Catches in 1992 decreased to 2,300t.

**Data and Assessment:** Commercial catch per unit of effort fluctuated widely in the late 1980s, reaching very high values in 1986 and 1989, perhaps reflecting increased concentrations of fish rather than higher stock sizes. Biomass estimates from research surveys have decreased from about 40,000-45,000t in the early 1980s, to about 2,500t in 1992. The geographical distribution of witch in the surveys changed suddenly in 1986 after the 1985 survey. The area of distribution has gradually decreased since. The fishery in recent years has been prosecuted in depths deeper than those covered by the survey.

**Fishing Mortality:**

**Recruitment:** The decrease in biomass from the mid-1980s implies that recruitment has been very small to non-existent during that period.

**State of the Stock:** The stock is presently the lowest recorded. The biomass outside of the survey area is not believed to be very high.

**Environmental Factors:** Harsh oceanographic conditions may have played a role in the decreased abundance of witch.

**Multispecies Considerations:**

**Long-term Prospects:** The prospects for rebuilding in the long term are unknown. Both the total and the spawning stock biomasses are far below any previous estimate in the 15-year time series.

**2.19. WITCH in 3Ps**  
**SUMMARY**  
 Figs. 1.19a - 1.19b

Year - Année	1986	1987	1988	1989	1990	1991	1992	1993	Min. <sup>1</sup>	Med. <sup>1</sup>	Max. <sup>1</sup>
Reference level/Niveau de référence '000t	3	3Max	1	1	1	1	1	1			
TAC - TPA '000t	3	3	1	1	1	1	1	1			
Rep.catches-Prises décl. '000t	1.3	1.3	.6	.9	1.0 <sup>2</sup>	1.1 <sup>2</sup>	1.0 <sup>2</sup>		.4	1.0	4.8
Unreported catches Prises non-déclarées											
Est.discards - Rejets est.											
Tot. catches - Prises Tot.											
Tot.biomass-Biomasse Tot.											
Sp.biomass-Biomasse Rep.											
Mean - F - Moyen											
<sup>1</sup> For/Pour 1960-1992 <sup>2</sup> Preliminary statistics/Statistiques provisoires											

**Forecast for 1994:** A quantitative forecast is not possible.

**Catches:** Catches have generally been about 1,000t since 1979.

**Data and Assessment:** Biomass has been estimated by research surveys since 1976. Biomass estimates were generally between 3,000t and 6,000t during the 1980s, with no identifiable persistent trend. Estimated biomass was about 2,000t in February 1993, but the 1993 April survey estimate increased to about 3,000t.

**Fishing Mortality:**

**Recruitment:**

**State of the Stock:** The state of the stock is uncertain. The 1993 survey estimates are within the range of variability during the last 10-15 years.

**Environmental Factors:**

**Multispecies Considerations:**

**Long-term Prospects:** Long term prospects are uncertain. The 1993 fishery was considered highly successful, however, it occurred on a very densely aggregated pre-spawning concentration and may not be representative of stock abundance.

**2.20. WITCH in 4RS**  
**SUMMARY**  
 Figs. 1.20a - 1.20c

Year - Année	1986	1987	1988	1989	1990	1991	1992	1993	Min. <sup>1</sup>	Med. <sup>1</sup>	Max. <sup>1</sup>
Reference level/Niveau de référence '000t	3.5	3.5	3.5	3.5	3.5	3.5	3.5	3.5			
TAC - TPA '000t	3.5	3.5	3.5	3.5	3.5	3.5	3.5	3.5			
Rep.catches-Prises décl. '000t	.7	.9	1.1	1.2	.6 <sup>2</sup>	.5 <sup>2</sup>	.4 <sup>2</sup>		.2	1.5	5.3
Unreported catches Prises non-déclarées											
Est.discards - Rejets est.											
Tot. catches - Prises Tot.											
Tot.biomass-Biomasse Tot.											
Sp.biomass-Biomasse Rep.											
Mean - F - Moyen											
<sup>1</sup> For/Pour 1960 to 1992 <sup>2</sup> Preliminary statistics/Statistiques provisoires											

**Forecast for 1994:** A quantitative forecast is not possible. However, based on the results of research surveys and the commercial fishery, catches are expected to remain low, particularly in 4R.

**Catches:** Catches have decreased steadily for the last three years. They have been lower than 1000t every year since 1983, except in 1988-89.

**Data and Assessment:** Qualitative interpretation of the research survey results and of the commercial fishery.

**Fishing Mortality:**

**Recruitment:**

**State of the Stock:** The abundance of this stock is thought to be low.

**Environmental Factors:**

**Multispecies Considerations:**

**Long-term Prospects:** Catches since 1960 for this stock have averaged 1,800t. Given the current stock size and age of recruitment, stock rebuilding is expected to be slow. The definition of the stock unit will be studied to determine if catches in 4T, close to the stock unit, should be assigned to 4RS witch.

**2.21. WITCH In 4V and in 4W**  
**SUMMARY**  
 Figs. 1.21a - 1.21c

Year - Année	1986	1987	1988	1989	1990	1991	1992	1993	Min. <sup>1</sup>	Med. <sup>1</sup>	Max. <sup>1</sup>
Reference level/Niveau de référence											
TAC - TPA	New Management Unit / Nouvelle Unité de Gestion										
Rep.catches-Prises décl. '000t						1.3 <sup>2,3</sup>	1.0 <sup>2,3</sup>				
Unreported catches Prises non-déclarées											
Est.discards - Rejets est.											
Tot. catches - Prises Tot.											
Tot.biomass-Biomasse Tot.											
Sp.biomass-Biomasse Rep.											
Mean - F - Moyen											
<sup>1</sup> For/Pour <sup>2</sup> Prior to 1991, species identification is unreliable / Avant 1991, l'identification spécifique n'est pas fiable. <sup>3</sup> Preliminary statistics/Statistiques provisoires											

**Forecast for 1994:** Catches are expected to decrease as a result of declining abundance.

**Catches:** Landings have been decreasing. The species identification is more reliable because witch command a higher price.

**Data and Assessment:** Estimates from a summer and a spring survey are used as indices of abundance.

**Fishing Mortality:**

**Recruitment:**

**State of the Stock:** Summer survey abundance estimates indicate stable biomasses at low values. The spring survey estimates declined from 1987 to 1990 but have remained stable since.

**Environmental Factors:**

**Multispecies Considerations:**

**Long-term Prospects:**

**2.22. WITCH in 4X  
SUMMARY  
Figs. 1.22a - 1.22b**

Year - Année	1986	1987	1988	1989	1990	1991	1992	1993	Min. <sup>1</sup>	Med. <sup>1</sup>	Max. <sup>1</sup>								
Reference level/Niveau de référence	<div style="border: 1px solid black; padding: 5px; display: inline-block; text-align: center;">           New Management Unit / Nouvelle Unité de Gestion         </div>																		
TAC - TPA																			
Rep.catches-Prises décl. '000t																.6 <sup>2,3</sup>	.8 <sup>2,3</sup>		
Unreported catches Prises non-déclarées																			
Est.discards - Rejets est.																			
Tot. catches - Prises Tot.																			
Tot.biomass-Biomasse Tot.																			
Sp.biomass-Biomasse Rep.																			
Mean - F - Moyen																			
<sup>1</sup> For/Pour <sup>2</sup> Prior to 1991, species identification is unreliable / Avant 1991, l'identification spécifique n'est pas fiable. <sup>3</sup> Preliminary statistics/Statistiques provisoires																			

**Forecast for 1994:** Catches are expected to decrease as a result of declining abundance.

**Catches:** Landings have been decreasing. The species identification is more reliable because witch command a higher price.

**Data and Assessment:** Estimates from a summer survey are used as indices of abundance.

**Fishing Mortality:**

**Recruitment:**

**State of the Stock:** Increasing catches may be due to increased fishing effort as a result of the introduction of individual quotas. Estimates of abundance from the surveys have been decreasing since 1984.

**Environmental Factors:**

**Multispecies Considerations:**

**Long-term Prospects:**

**2.23. YELLOWTAIL in 4V and 4W**  
**SUMMARY**  
 Figs. 1.23a - 1.23b

Year - Année	1986	1987	1988	1989	1990	1991	1992	1993	Min. <sup>1</sup>	Med. <sup>1</sup>	Max. <sup>1</sup>		
Reference level/Niveau de référence	<div style="border: 1px solid black; padding: 5px; display: inline-block;">           New Management Unit / Nouvelle Unité de Gestion         </div>												
TAC - TPA													
Rep.catches-Prises décl. '000t												1.3 <sup>2,3</sup>	1.4 <sup>2,3</sup>
Unreported catches Prises non-déclarées													
Est.discards - Rejets est.													
Tot. catches - Prises Tot.													
Tot.biomass-Biomasse Tot.													
Sp.biomass-Biomasse Rep.													
Mean - F - Moyen													
<sup>1</sup> For/Four <sup>2</sup> Prior to 1991, species identification is unreliable / Avant 1991, l'identification spécifique n'est pas fiable. <sup>3</sup> Preliminary statistics/Statistiques provisoires													

**Forecast for 1994:** Landings are expected to remain stable or increase slightly.

**Catches:** Landings data are not reliable because of problems with species identification and reporting.

**Data and Assessment:** Estimates from a summer and a spring survey are used as indices of abundance.

**Fishing Mortality:**

**Recruitment:**

**State of the Stock:** Estimates of abundance from the summer surveys have generally been stable with perhaps an increase recently. The estimates from the spring surveys have generally decreased since 1988.

**Environmental Factors:**

**Multispecies Considerations:**

**Long-term Prospects:**

**2.24. YELLOWTAIL In 4X**  
**SUMMARY**  
 Fig. 1.24a

Year - Année	1986	1987	1988	1989	1990	1991	1992	1993	Min. <sup>1</sup>	Med. <sup>1</sup>	Max. <sup>1</sup>							
Reference level/Niveau de référence	<div style="border: 1px solid black; padding: 5px; display: inline-block;">           New Management Unit / Nouvelle Unité de Gestion         </div>																	
TAC - TPA																		
Rep.catches-Prises décl. '000t														.15 <sup>2,3</sup>	.12 <sup>2,3</sup>			
Unreported catches Prises non-déclarées																		
Est.discards - Rejets est.																		
Tot. catches - Prises Tot.																		
Tot.biomass-Biomasse Tot.																		
Sp.biomass-Biomasse Rep.																		
Mean - F - Moyen																		
<sup>1</sup> For/Pour <sup>2</sup> Prior to 1991, species identification is unreliable / Avant 1991, l'identification spécifique n'est pas fiable. <sup>3</sup> Preliminary statistics/Statistiques provisoires																		

**Forecast for 1994:** Catches are expected to remain stable at a low level.

**Catches:** Landings data are not reliable because of problems with species identification and reporting.

**Data and Assessment:** Estimates from summer surveys are used as indices of abundance.

**Fishing Mortality:**

**Recruitment:**

**State of the Stock:** Based on the surveys, the stock appears stable at a low level, and perhaps slightly increasing.

**Environmental Factors:**

**Multispecies Considerations:**

**Long-term Prospects:**

## 2.25. ATLANTIC HALIBUT in 3N, 3O, 3Ps, 4V, 4W, and in 4X

**SUMMARY**

Figs. 1.25a - 1.25d

Year - Année	1986	1987	1988	1989	1990	1991	1992	1993	Min. <sup>1</sup>	Med. <sup>1</sup>	Max. <sup>1</sup>
Reference level/Niveau de référence '000t	-	-	3.2	3.2	3.2	3.2	3.2	3.2			
TAC - TPA '000t	-	-	3.2	3.2	3.2	3.2	3.2	3.2			
Rep.catches-Prises décl. '000t	3.3	2.6	2.3	1.9	2.1 <sup>2</sup>	2.2 <sup>2</sup>	1.3 <sup>2</sup>		1.1	1.9	4.0
Unreported catches Prises non-déclarées											
Est.discards - Rejets est.											
Tot. catches - Prises Tot.											
Tot.biomass-Biomasse Tot.											
Sp.biomass-Biomasse Rep.											
Mean - F - Moyen											
<sup>1</sup> For/Pour 1961-1992. <sup>2</sup> Preliminary statistics/Statistiques provisoires											

**Forecast for 1994:** The Atlantic halibut stock size appears to be decreasing and catches are expected to continue to decline.

**Catches:** Catches have decreased more or less steadily from a maximum of 4,000t in 1985 to 1,331 in 1992.

**Data and Assessment:** Landings, commercial catch rates and biomass estimates from research surveys were used as indices of abundance. The landings suggest a decreasing stock size while the commercial catch rates have decreased markedly since 1988 despite technological improvements to fishing. The biomass estimates from research surveys have increased from 1983 to 1989, but they have fluctuated since, perhaps with a downward trend.

**Fishing Mortality:**

**Recruitment:**

**State of the Stock:** The stock is decreasing based on declining commercial catch rates and landings. The stock is now less abundant than when the 3,200t TAC was established.

**Environmental Factors:**

**Multispecies Considerations:**

**Long-term Prospects:**



## 2.26. ATLANTIC HALIBUT in 4R, 4S and in 4T

SUMMARY

Fig. 1.26a

Year - Année	1986	1987	1988	1989	1990	1991	1992	1993	Min. <sup>1</sup>	Med. <sup>1</sup>	Max. <sup>1</sup>
Reference level/Niveau de référence '000t	-	-	.3	.3	.3	.3	.3	.3			
TAC - TPA '000t	-	-	.3	.3	.3	.3	.3	.3			
Rep.catches-Prises décl. '000t		.3	.2	.3	.4 <sup>2</sup>	.3 <sup>2</sup>	.2 <sup>2</sup>		.091	.189	.411
Unreported catches Prises non-déclarées											
Est.discards - Rejets est.											
Tot. catches - Prises Tot.											
Tot.biomass-Biomasse Tot.											
Sp.biomass-Biomasse Rep.											
Mean - F - Moyen											
<sup>1</sup> For/Pour 1979-1992 <sup>2</sup> Preliminary statistics/Statistiques provisoires											

**Forecast for 1994:** It is not possible to make a quantitative forecast.

**Catches:** Catches have exceeded the TAC in 1990 and 1991. The 1992 catches are substantially lower.

**Data and Assessment:** Biological update based on examination of landings data and limited information on catch composition.

**Fishing Mortality:**

**Recruitment:**

**State of the Stock:** Landings increased from 1979 to 1990 although there was considerable interannual variability but they have abruptly decreased since. This may indicate lower stock abundance or may be the result of lower fishing effort or lower availability of the halibut.

**Environmental Factors:**

**Multispecies Considerations:**

**Long-term Prospects:**

**2.27. GREENLAND HALIBUT in 4R, 4S and in 4T**  
**SUMMARY**  
 Figs. 1.27a - 1.27c

Year - Année	1986	1987	1988	1989	1990	1991	1992	1993	Min. <sup>1</sup>	Med. <sup>1</sup>	Max. <sup>1</sup>
Reference level/Niveau de référence '000t	5	-	-	-	-	-	-	4			
TAC - TPA '000t	5	8.9	10.5	10.5	10.5	10.5	10.5	4			
Rep.catches-Prises décl. '000t	6.5	11	8	5	2.4 <sup>2</sup>	2.3 <sup>2</sup>	3.4 <sup>2</sup>		.7	2.3	11
Unreported catches Prises non-déclarée											
Est.discards - Rejets est.											
Tot. catches - Prises Tot.											
Tot.biomass-Biomasse Tot.											
Sp.biomass-Biomasse Rep.											
Mean - F - Moyen											
<sup>1</sup> For/Pour 1970-1992 <sup>2</sup> Preliminary statistics/Statistiques provisoires											

**Forecast for 1994:** Catches are expected to increase as a result of increased fishing effort and perhaps increased abundance.

**Catches:** Catches have fluctuated as a result of fluctuations in recruitment. Catches increased in 1992 for the first time since 1987.

**Data and Assessment:** Estimates from a summer research survey suggest that the biomass increased sharply from 1990 to 1991 but only slightly in 1992.

**Fishing Mortality:** The fishing mortality is not known precisely, but it is likely quite high.

**Recruitment:** It is too early to estimate recruiting year-classes with precision, but there are some positive signs from the surveys and the shrimpers that recruitment may be increasing.

**State of the Stock:** The stock was quite low but may be increasing.

**Environmental Factors:**

**Multispecies Considerations:**

**Long-term Prospects:** Not known. Will depend on future recruitment. However sustained rebuilding is unlikely unless exploitation rates are decreased substantially.

**2.28. COD in 4Vn during May to December**  
**SUMMARY**

Year - Année	1986	1987	1988	1989	1990	1991	1992	1993	Min. <sub>1</sub>	Med. <sup>1</sup>	Max. <sub>1</sub>
Reference level - Niveau de référence '000t	10	6.1	7.5	7.5	7.5	7.5-10	decrease	1.8			
TAC - TPA '000t	12	9	7.5	7.5	7.5	10	10	1.8			
Rep.catches-Prises décl. '000t	12	10.5	9	7.6	5.2 <sup>2</sup>	4.6 <sup>2</sup>	4.3 <sup>2</sup>				
Unreported catches Prises non-déclarées											
Est.discards - Rejets est.											
Tot. catches - Prises Tot.											
Tot.biomass-Biomasse Tot.											
Sp.biomass-Biomasse Rep.											
Mean - F - Moyen											
<sup>1</sup> For/Pour <sup>2</sup> Preliminary statistiques/Statistiques provisoires											

**Forecast for 1994:** No quantitative forecast possible.

**Catches:** Catches have decreased rapidly in the last five years, particularly in the fixed gear sector which has been unable to catch its allocation in the past three years.

**Data and Assessment:** Stock mixing with neighboring stocks in this area precludes an analytical assessment. Research vessel survey biomass estimates are available since 1970. They are highly variable because of stock mixing and small sample size. Information on fishing effort is available only for a small portion of the fleets and is not considered a reliable index of stock size.

**Fishing Mortality:** Fishing mortality is not estimated precisely, but is likely above  $F_{0.1}$ .

**Recruitment:** The 1986 and 1987 year-classes are the only ones above average in the stock. More recent year-classes do not appear strong.

**State of the Stock:** The longliner catches are very poor, and a major portion of the landings are coming from migrating 4T fish. The stock abundance is very low.

**Environmental Factors:** Declining abundance may have been exacerbated by cooling trends experienced throughout this general area.

**Multispecies Considerations:**

**Long-term Prospects:** Rebuilding will be slow and may require a substantial reduction in exploitation rate.

## 2.29. REDFISH IN 2+3K SUMMARY

Year - Année	1986	1987	1988	1989	1990	1991	1992	1993	Min.	Med.	Max
Reference level - Niveau de référence	35	35	35	35	35	20	20	20			
TAC - TPA '000t	35	35	35	35	35	20	20 <sup>4</sup>	20 <sup>4</sup>	20 <sup>1</sup>	32 <sup>1</sup>	35 <sup>1</sup>
Rep.catches - Prises déclarées '000t	27	19	7	3	2.4 <sup>3</sup>	0.4 <sup>3</sup>	0 <sup>3</sup>		0 <sup>2</sup>	25 <sup>2</sup>	130 <sup>2</sup>
Unreported catches Prises non-déclarées											
Est.discards - Rejets est.											
Tot.catches - Prises Tot.											
Tot.biomass-Biomasse Tot.											
Sp.biomass-Biomasse Rep.											
Mean - F - Moyen											
<sup>1</sup> For 1974-1993/Pour 1974-1993 <sup>2</sup> For 1960-1992/Pour 1960-1992 <sup>3</sup> Preliminary statistics/Statistiques provisoires <sup>4</sup> 1991-1993 TAC - multi-year management plan/1991-1993 TPA - le plan pluri-annuel											

**Forecast for 1994:** Although there is no information to precisely estimate fishing mortality or exploitation rate generated by recent catches, it is considered that catches in the order of the present TAC (20,000 t) would be very detrimental to the population if achieved.

**Catches:** Catches since 1960 ranged from 9t to 130,000t. Between 1961 and 1977, catches averaged about 28,000t. In the early 1980s, landings ranged from 14,000t to 18,000t and increased to between 24,000t to 29,000t from 1984 to 1986 in response to improved market's. Since 1986, landings have drastically declined annually to the record low of about 9t in 1992. These reductions have come about because of persistent complaints of external parasite infestation and a diversion of effort by the principal Canadian harvester to other fisheries because of low catch rates.

**Data and Assessment:** The information is not adequate for an analytical assessment. Standardized commercial CPUE shows high variability between some years but indicates a general decrease from 1984 to 1990. Limited fishing effort has occurred since 1990. Research vessel trawl surveys to 2J and 3K indicate declines in biomass in both divisions since the early 1980s. Trawlable biomass estimates since 1989 are consistently low in 2J and 3K and indicate that the population is at a very low level compared to estimates from the early 1980s.

**Fishing mortality:**

**Recruitment:** There has been no substantial recruitment since the year-classes of the early 1970s.

**State of the Stock:** The stock is at a low level due to poor recruitment. The 1992 survey of Div. 2J3K indicates trawlable biomass to be at a historically low level.

**Environmental Factors:**

**Multi-species considerations:**

**Long-term Prospects:** The stock will continue to decline until good recruitment takes place, and prospects for the fishery will not improve until 8-10 years after good recruitment occurs.

### 2.30. Redfish in 30 SUMMARY

Year - Année	1986	1987	1988	1989	1990	1991	1992	1993	Min.	Med.	Max.
Reference level - Niveau de référence '000t	20	20	14	14	14	14	14	14			
TAC - TPA '000t	20	20	14	14	14	14 <sup>4</sup>	14 <sup>4</sup>	14 <sup>4</sup>	14 <sup>1</sup>	18 <sup>1</sup>	21.9 <sup>1</sup>
Rep. catches-Prises décl. '000t	10	13	11	11	9 <sup>3</sup>	7.5 <sup>3</sup>	9.5 <sup>3</sup>		5 <sup>2</sup>	13.3 <sup>2</sup>	25 <sup>2</sup>
Unreported catches Prises non-déclarées est. '000t		11	13.5	-	1.9	0.4	1.5				
Est. discards - Rejets est.											
Tot. catches - Prises Tot.											
Tot. biomass-Biomasse Tot.											
Sp. biomass-Biomasse Rep.											
Mean F - Moyen											

<sup>1</sup> For 1974-1993/Pour 1974-1993  
<sup>2</sup> For 1959-1992/Pour 1959-1992  
<sup>3</sup> Preliminary statistics/Statistiques provisoires  
<sup>4</sup> 1991-1993 TAC - multi-year management plan/1991-1993 TPA - le plan pluri-annuel

**Forecast for 1994:** There is no information upon which to base a forecast of this stock.

**Catches:** Catches since 1959 have ranged between 5,000t and 25,000t. From 1980 to 1986, an average about 11,000t was taken. In 1987, catches increased to 24,000t and remained at that level in 1988. In 1989 catches declined to 11,000t and have been at this level ever since. The increase in 1987 and 1988 was due to the activity of fleets that are not members of NAFO (primarily those of Panama). Russia and Cuba account for most of the catch. Canada has taken less than 300 t per year since 1983.

**Data and Assessment:** The information is not adequate for an analytical assessment. Estimates of relative abundance from research vessel surveys are associated with high variability and are not considered indicative of population trends. Standardized commercial CPUE shows much interannual variability before 1982. Since 1982 there has been a general decline in this index. The year-classes of the early 1980s are dominant in the fishery.

**Fishing mortality:**

**Recruitment:** Relative length distributions indicate a pulse of recruitment that occurred in the spring 1991 survey at mode of 11-12cm corresponding to the 1988-89 year-classes. These year-classes comprised 14% of the research catch numbers in the 1992 fall survey. The magnitude of these year-classes is unknown but should start recruiting to the fishery by 1996.

**State of the Stock:** There is no information to determine stock size. The CPUE index is indicating a general decline since 1982 and the contribution expected from the 1988-89 year-classes is unknown. There is no information to precisely estimate fishing mortality or exploitation rate generated by catches that have been in the range of 11,000t since 1989.

**Environmental Factors:**

**Multi-species Considerations:**

**Long-term Prospects:** Redfish stocks are noted for recruitment occurring only periodically. This leads to wide fluctuations in stock abundance. Given that the incidence of strong year-classes is infrequent and that growth rates are very low, fishing mortalities on redfish stocks must be maintained at low levels.

### 2.31. REDFISH IN LAURENTIAN CHANNEL SUMMARY

Year - Année	1986	1987	1988	1989	1990	1991	1992	1993	Min. <sup>1</sup>	Med. <sup>1</sup>	Max. <sup>1</sup>
Reference level - Niveau de référence '000t								25			
TAC - TPA '000t	-	-	-	-	-	-	25 <sup>2</sup>	25	25	25	25
Rep.catches-Prises déclarées '000t	11	14	11	15	15 <sup>3</sup>	20 <sup>3</sup>	17 <sup>3</sup>	-	8	25	58
Unreported catches Prises non-déclarées											
Est.discard - Rejets est.											
Tot.catches - Prises Tot.											
Tot.biomass-Biomasse Tot.											
Sp.biomass-Biomasse Rep.											
Mean - F - Moyen											
<sup>1</sup> For 1960-1992 except TAC which is only for 1992-93 <sup>2</sup> Interim TAC advised for this revised management unit <sup>3</sup> Preliminary statistics/Statistiques provisoires											

**Forecast for 1994:** Catch rates will decline somewhat until recruitment of the 1984-85 year-classes enters the fishery.

**Catches:** Catches ranged from 8,100t (1984) to 58,000t (1971). Catches were in the vicinity of 20,000 t from 1960-1968, increased to an average of 43,000t from 1969 to 1975 then declined steadily to the lowest on record in 1984 at 8,100t. Since 1984, landings increased steadily to 20,000t in 1991. The 1992 catch was 17,000t.

**Data and Assessment:** The standardized catch rate series shows large increases in 1989 and again in 1990 followed by successive decreases in 1991 and 1992. These are considered too dynamic to reflect changes in abundance. Research vessel trawl surveys are not considered reflective of stock abundance. Production models using catch and standardized effort did not result in reliable parameter estimates.

#### Fishing Mortality:

**Recruitment:** Length frequencies from the 1993 February research survey in Div. 3Ps show two modes, one at 14-15 cm which corresponds to the 1987-88 year-classes and another at 21-23 cm which corresponds to the 1984-85 year-classes. Both of these year-classes have yet to recruit to the fishery. These pulses together represented about one third of the research catch.

**State of the Stock:** There is no information to determine estimates of stock size in 1993. The stock appears healthy with the good year-classes of the early 1980s well represented in the fishery. The exploitable stock should also be augmented by the year-classes of 1984-85 and 1987-88 in the mid-1990s and again near the turn of the century. There is no information to precisely estimate fishing mortality or the exploitation rate generated by catches that have been in the vicinity of 18,000 t for 1991 and 1992.

#### Environmental Factors:

#### Multi-species Considerations:

**Long-term Prospects:** Redfish stocks are noted for recruitment occurring only periodically. This leads to wide fluctuations in stock abundance. Given that the incidence of strong year-classes is infrequent and that growth rates are very low, fishing mortalities on redfish stocks must be maintained at low levels.

### 2.32. WHITE HAKE IN 4T SUMMARY

Year - Année	1986	1987	1988	1989	1990	1991	1992	1993	Min.	Med.	Max.
Reference level - Niveau de référence	12	-	5.5	5.5	N/A	N/A	N/A	5.5			
TAC - TPA '000t	12	9.4	5.5	5.5	5.5	5.5	5.5	5.5	12.0 <sup>1</sup>	5.5 <sup>1</sup>	5.5 <sup>1</sup>
Rep.catches-Prises décl. '000t	5	6.4	3.9	5.3	4.9 <sup>2</sup>	4.7 <sup>2</sup>	3.5 <sup>2</sup>		14.0 <sup>1</sup>	3.5 <sup>1</sup>	6.1 <sup>1</sup>
Unreported catches Prises non-déclarées											
Est.discards - Rejets est.											
Tot.catches - Prises Tot.											
Tot.biomass-Biomasse Tot.											
Sp.biomass-Biomasse Rep.											
Mean - F - Moyen											
<sup>1</sup> For/Pour 1982-1992 <sup>2</sup> Preliminary statistics/Statistiques provisoires											

**Forecast for 1994:** The precautionary TAC of 5,500t appears to represent a high rate of exploitation. However, given the uncertainties about stock definition, there is no firm basis to suggest a modification of the 5,500t TAC.

**Catches:** Since 1970, the average annual catch of white hake has been 6,100t. During this time, catches have declined from a maximum in 1981 (14,039t) to a minimum in 1992 (3,547t), with the greatest decline occurring in the gillnet component. The majority of the landings (80%) are taken in the Northumberland Strait, off the western end of P.E.I. and between P.E.I. and Cape Breton Island in July and August.

**Data and Assessment:** An SPA assessment has not been conducted since 1989 due to the lack of a reliable index of abundance and because of concerns about stock definition within the 4T management unit.

**Fishing Mortality:** An analysis of estimates of instantaneous mortality rates from the 1992 research surveys, suggested that fishing mortality has probably been high (approx. 1.0) during the past several years.

**Recruitment:** Indications from the commercial fishery and research vessel survey are that recruitment has not been above average.

**State of the Stock:** The research survey data indicates that recruitment has not been above average and that fishing mortality appears to be high. Fewer old white hake were caught in 1990 and 1991, making this fishery even more dependent on a few age classes than in the past. As a result, this fishery will be sensitive to annual fluctuations in recruitment. Research vessel estimates of population abundance and biomass for 1990 and 1991 were below average for the period 1986-1991.

**Environmental Factors:**

**Multi-species Considerations:** White hake are frequently caught by inshore trawlers targeting winter flounder in the Northumberland Strait.

**Long-term Prospects:** Catches from this resource have averaged 6,100t since 1970 but have declined to a minimum of 3,547t in 1992. Indications are that recruitment has been below average since 1990 and that fishing mortality has been high. Recovery of this resource will depend on the occurrence of favourable recruitment.

Cod in 2J-3KL

Fig. 1 .1a. Total catches (t) and TACs (t)

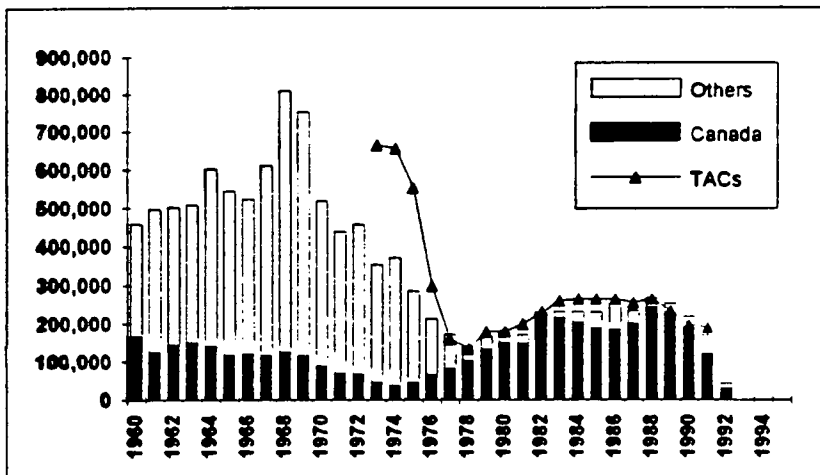
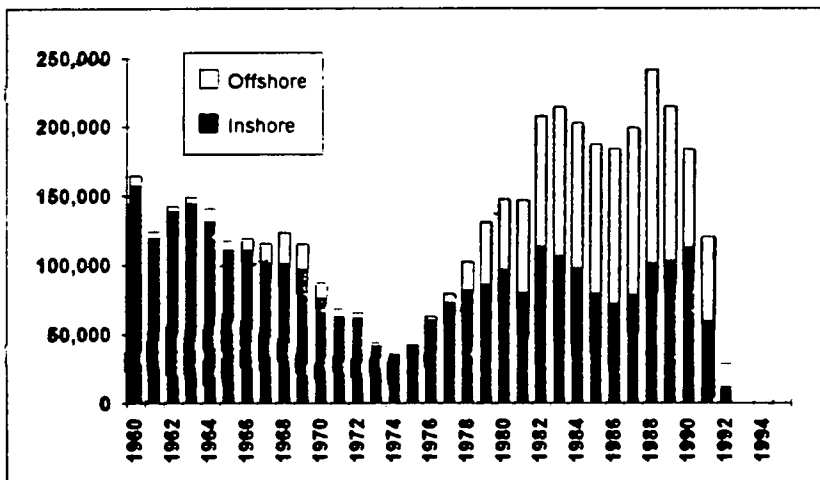
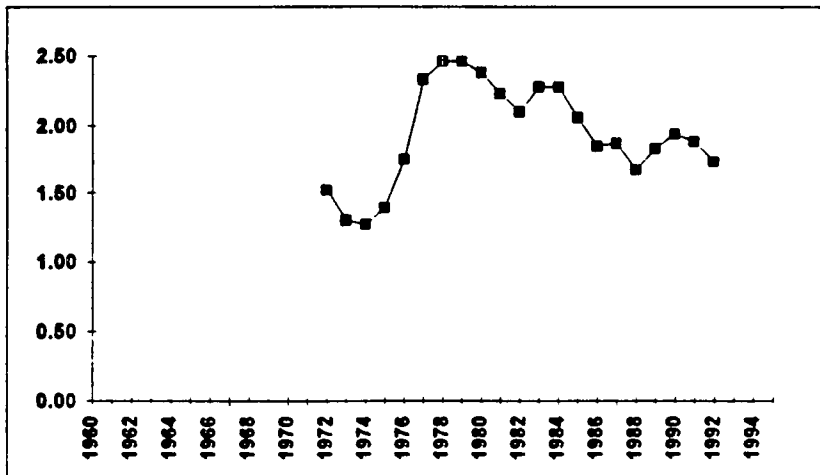

Fig. 1 .1b. Inshore and Offshore Canadian Catches (t)



Cod in 2J-3KL

Fig. 1 .1c. Mean Weight (kg) at age 7





Cod in 2J-3KL

Abundance Indices

Fig. 1 .1d. RV Abundance - 2J ('000)

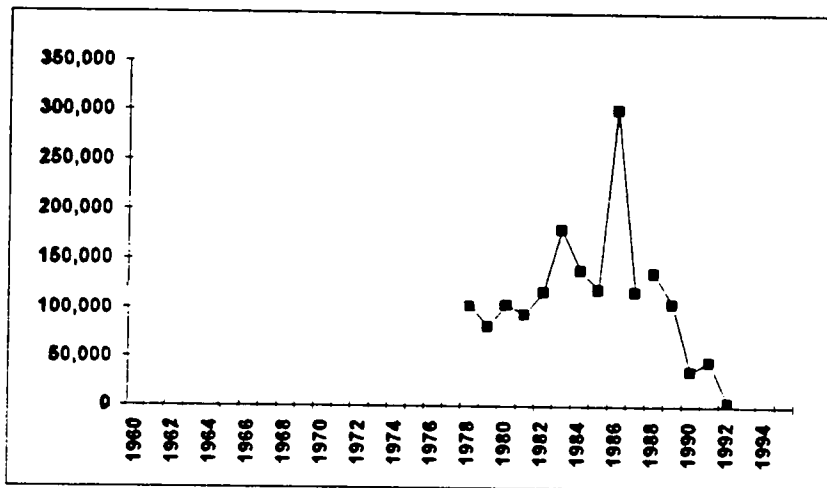

RV Biomass - 2J (t)

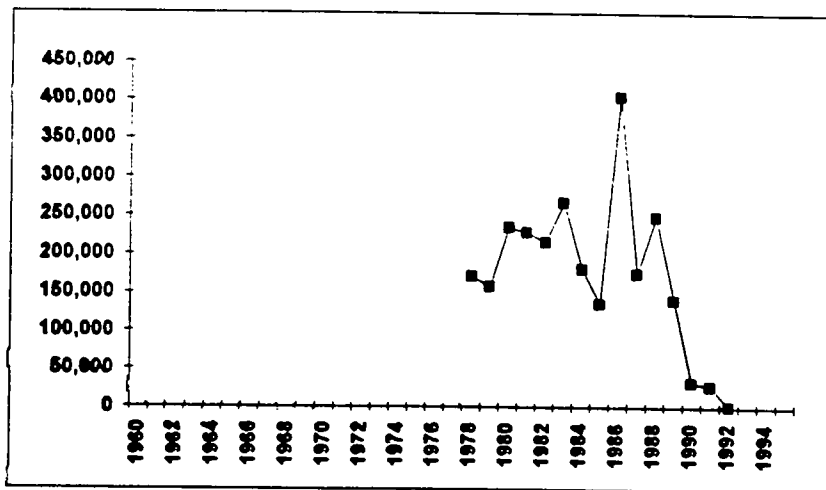

Cod in 2J-3KL

Abundance Indices

Fig. 1.1e.

RV Abundance - 3K ('000)

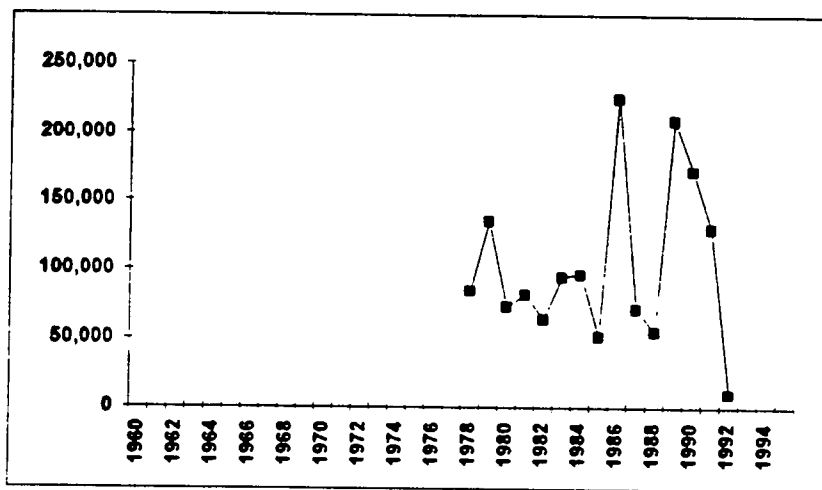

RV Biomass - 3K (t)

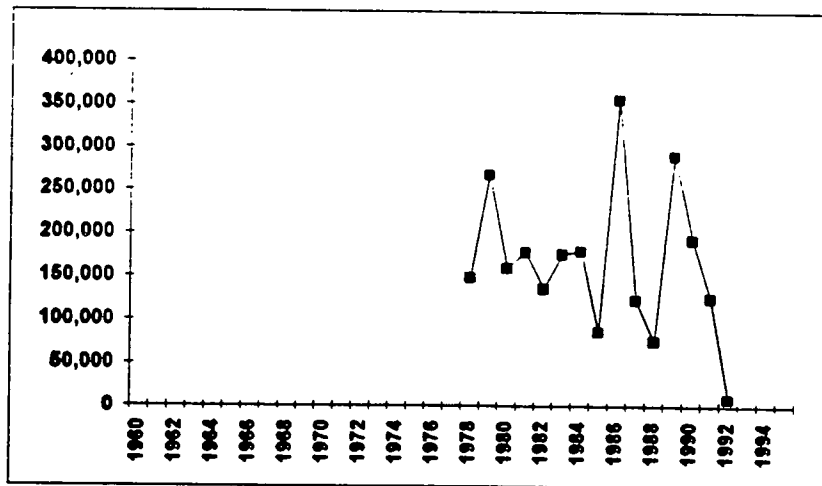

Cod in 2J-3KL

Abundance Indices

Fig. 1 .1f.

RV Abundance - 3L ('000)

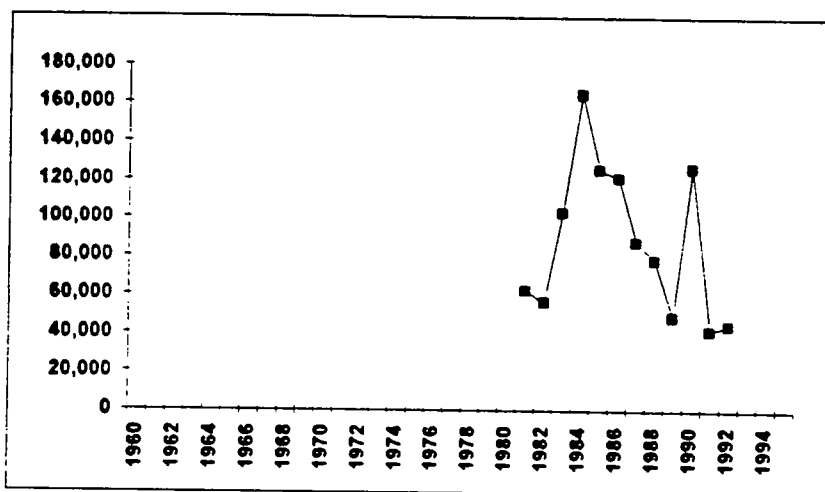

RV Biomass - 3L (t)

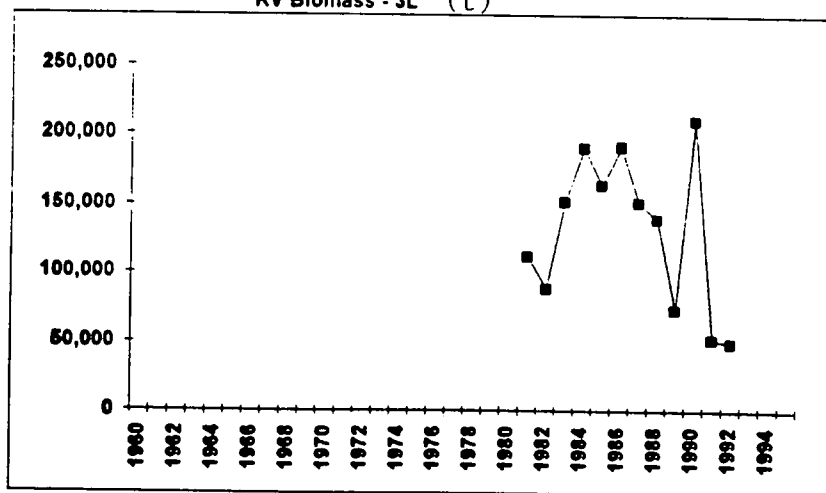

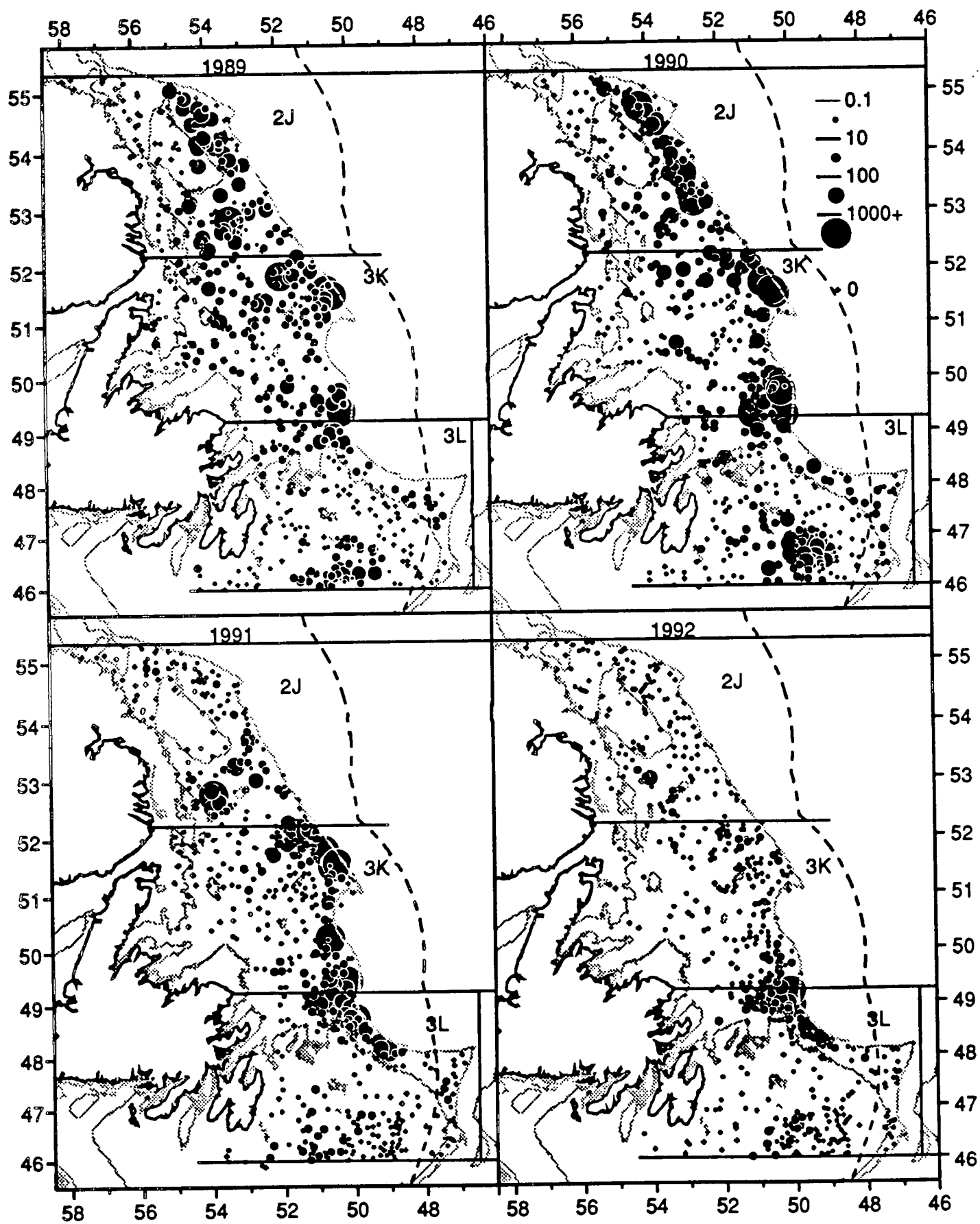
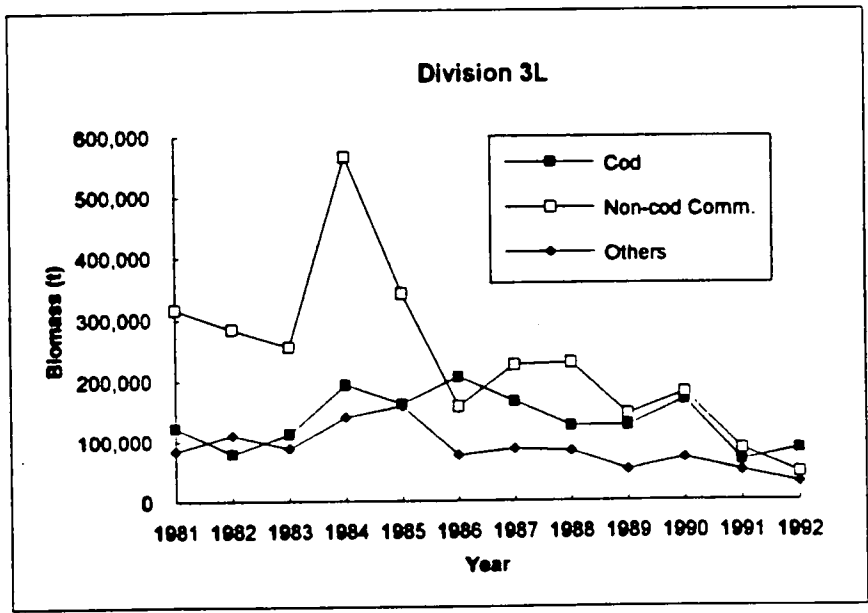
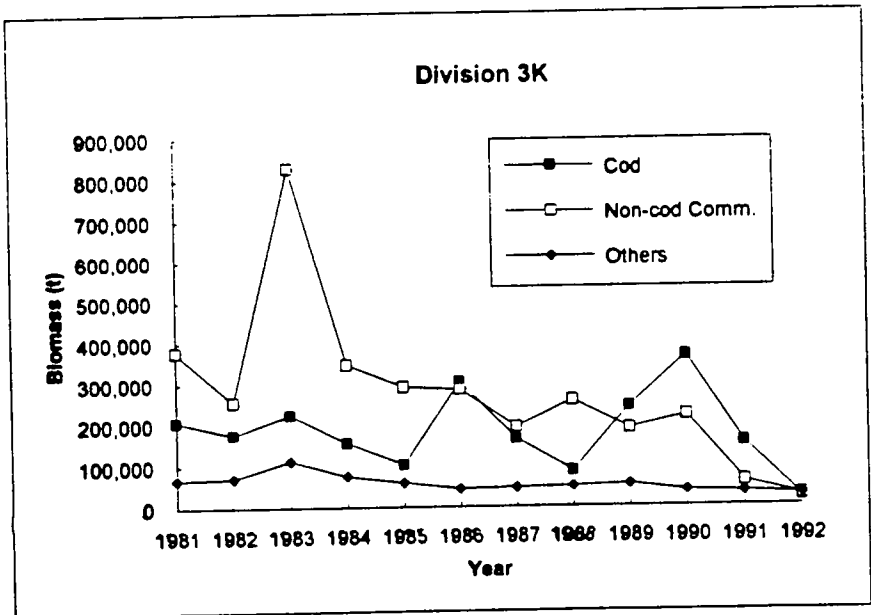
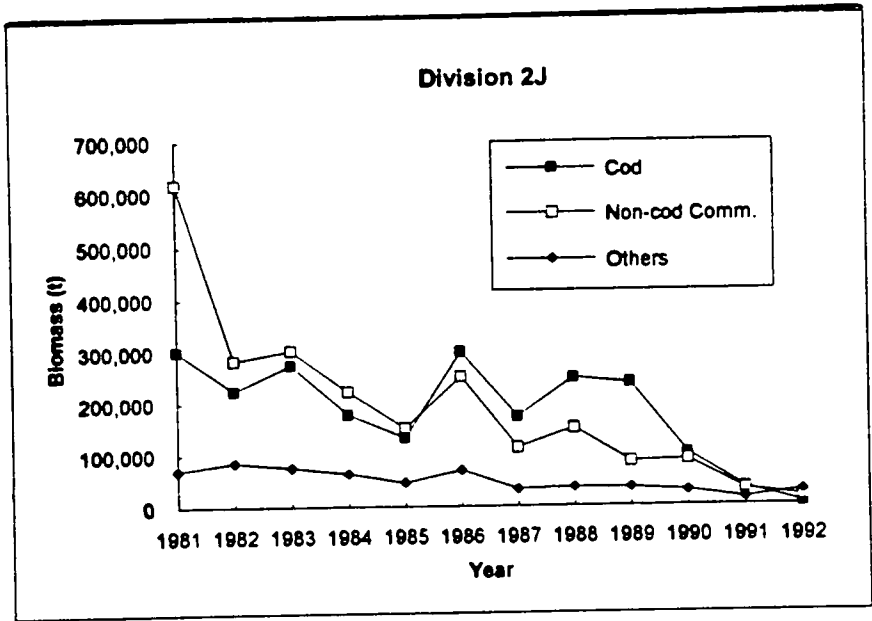

Fig. 1.1h. Biomass trends of commercial and non-commercial demersal species estimated during research vessel survey



Cod in 3Ps

Fig. 1 .2a. Total catches (t) and TACs (t)

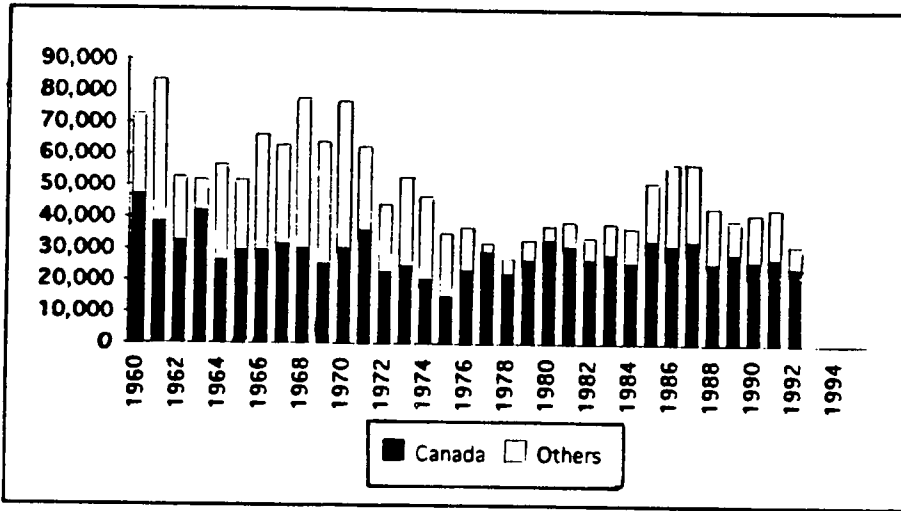
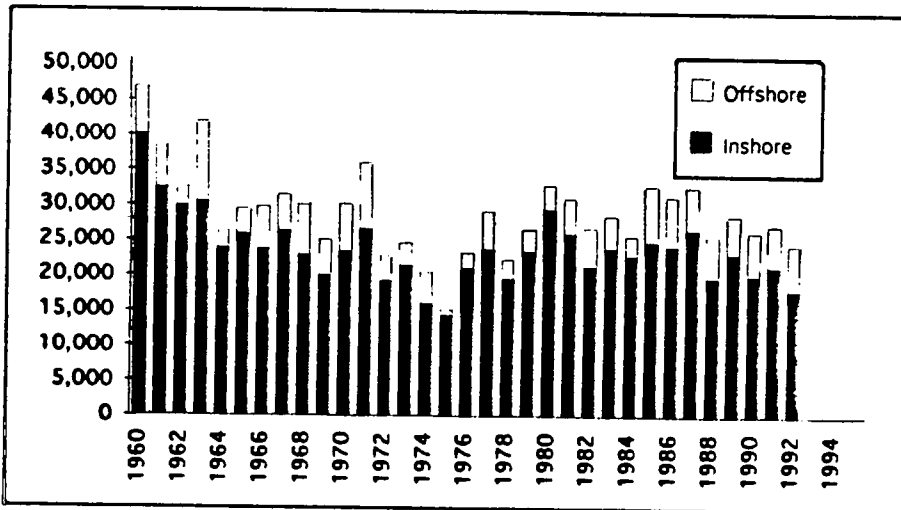

Fig. 1 .2b. Inshore and Offshore Canadian Catches (t)



Cod in 3Ps

SPA

Fig. 1.2c. Mean Weight (kg) at age 7

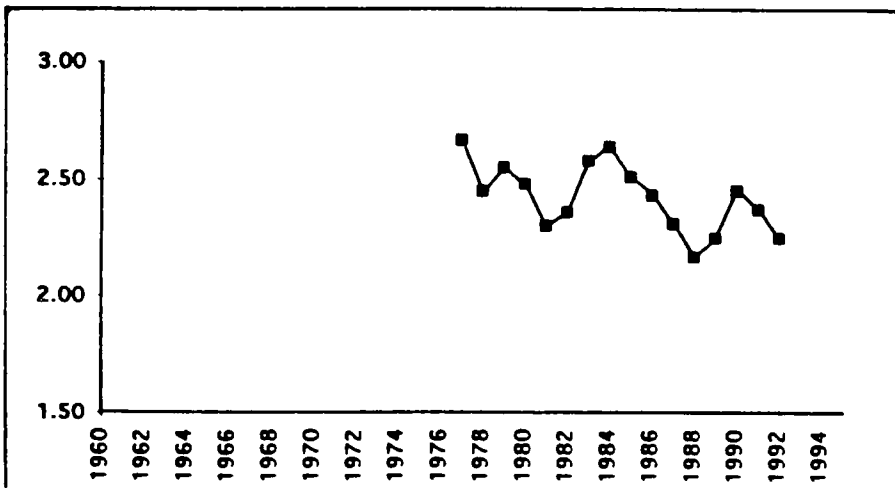

Fig. 1.2d.

RV Canada (kg/ton)

All ages

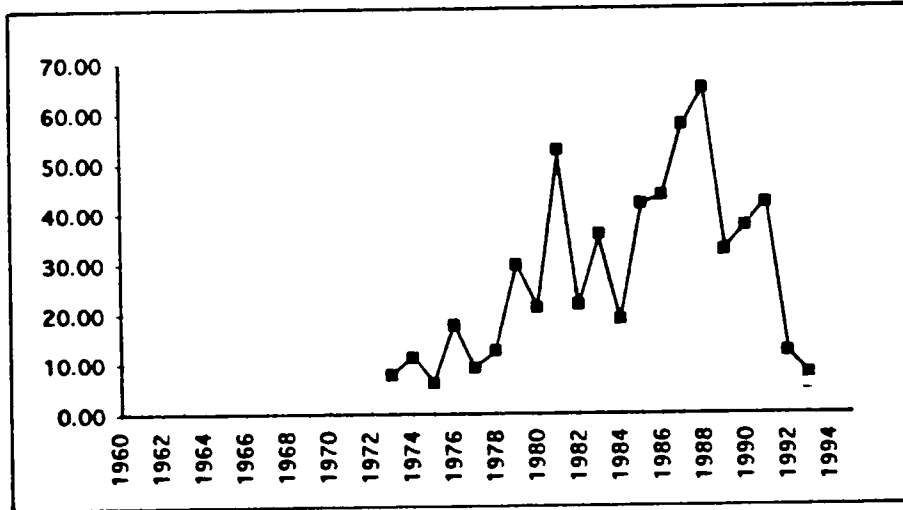
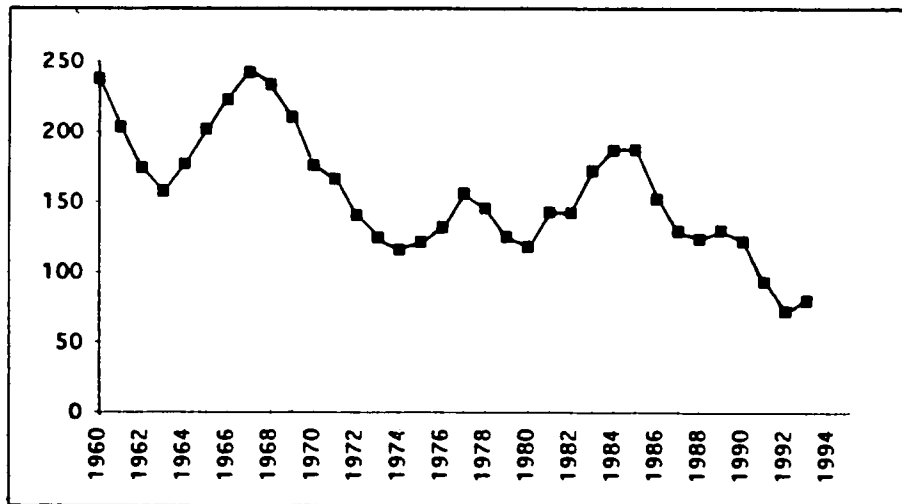

Fig. 1.2e.

Total Abundance (million)

3+



Cod in 3Ps

SPA

Fig. 1.2f.

Annual fishing mortality rates.

6+

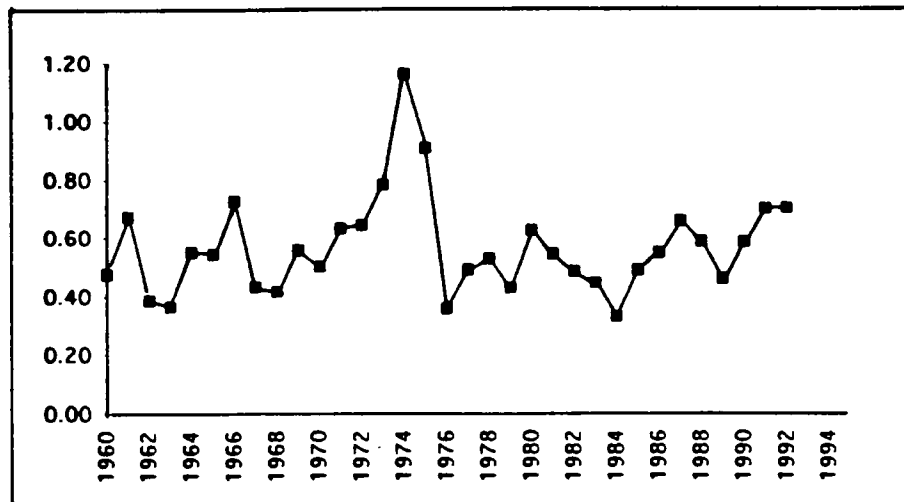

Fig. 1 .3a. Total catches (t) and TACs (t).

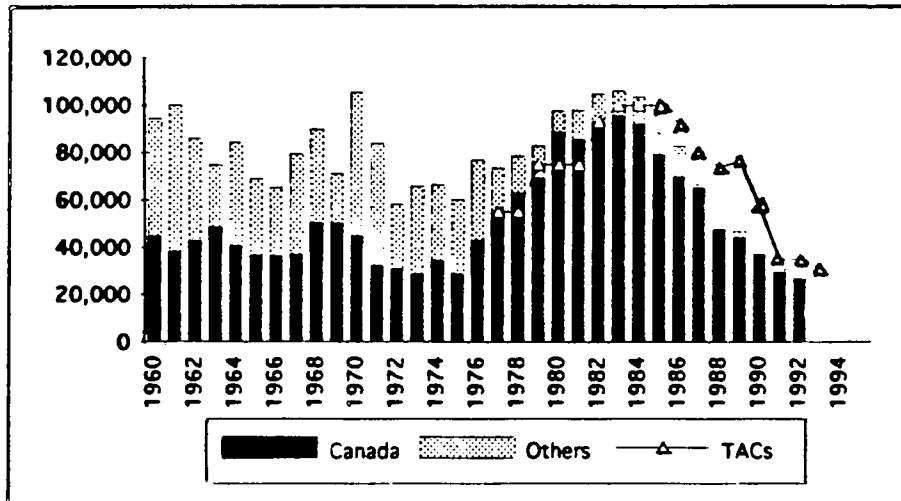

Fig. 1 .3b . Fixed and Mobile Sectors: Canadian Catches (t).

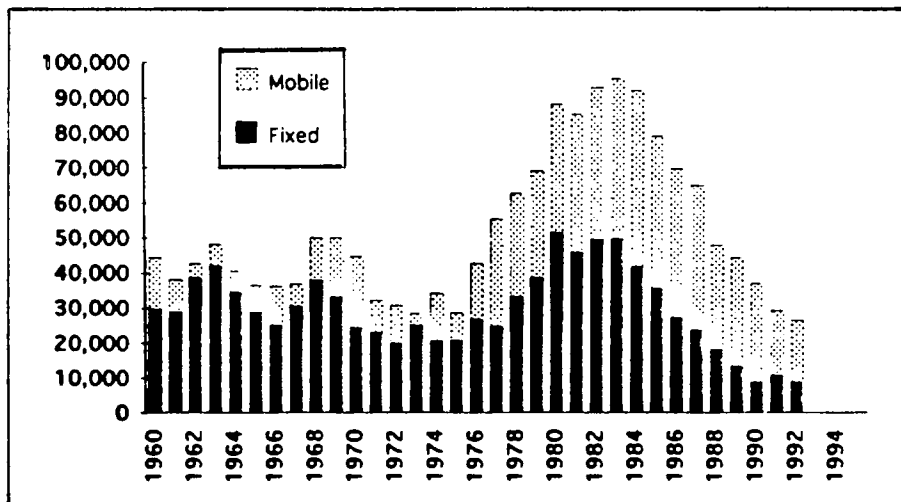

Fig. 1.3c. Mean Weight (kg).

at age 7

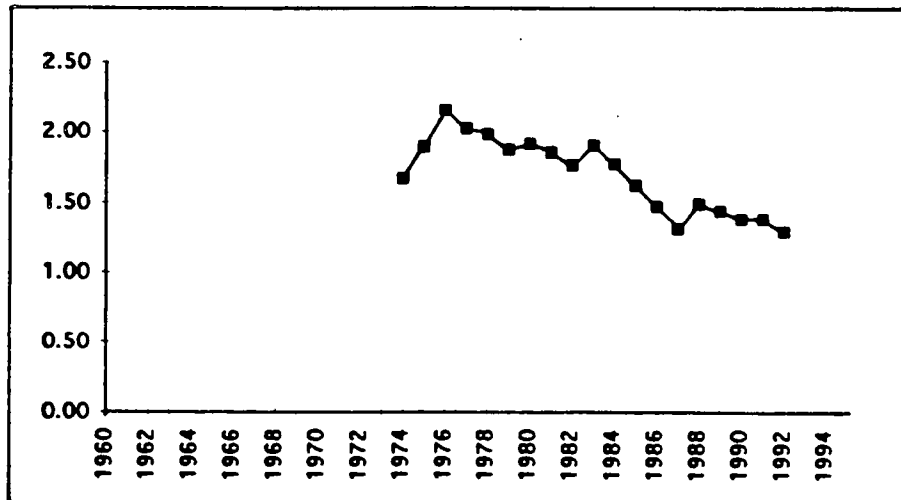
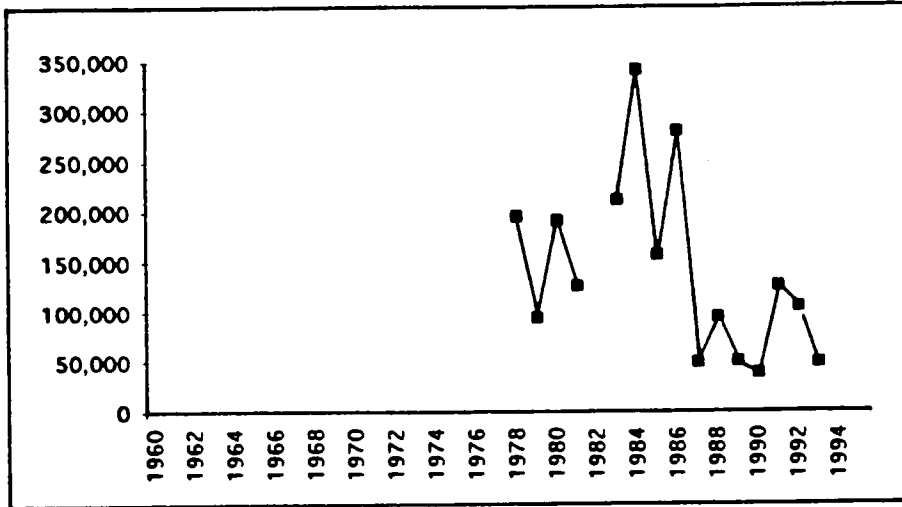



Fig. 1.3d. Biomass (t) - winter.

All ages



Cod in 3Pn-4RS

ADAPT

Fig. 1.3e. Total Abundance (million).

3+

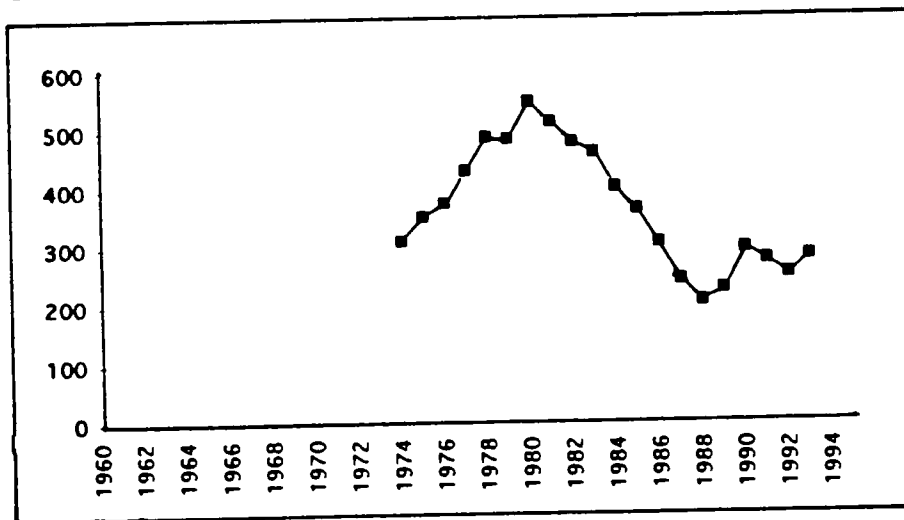

Fig. 1.3f. Recruitment (million).

Age 3

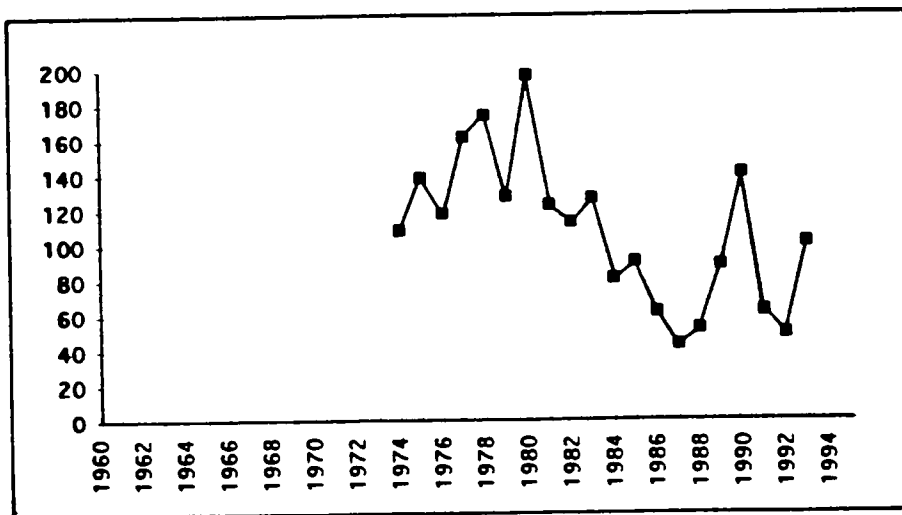

Fig. 1.3g. Total Biomass (thousand tonnes).

3+

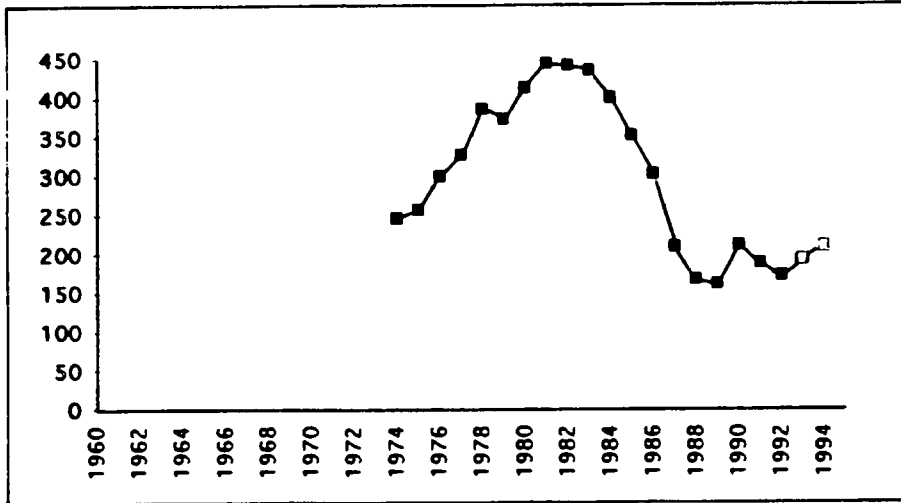

Fig. 1.3h. Adult Biomass (thousand tonnes).

7+

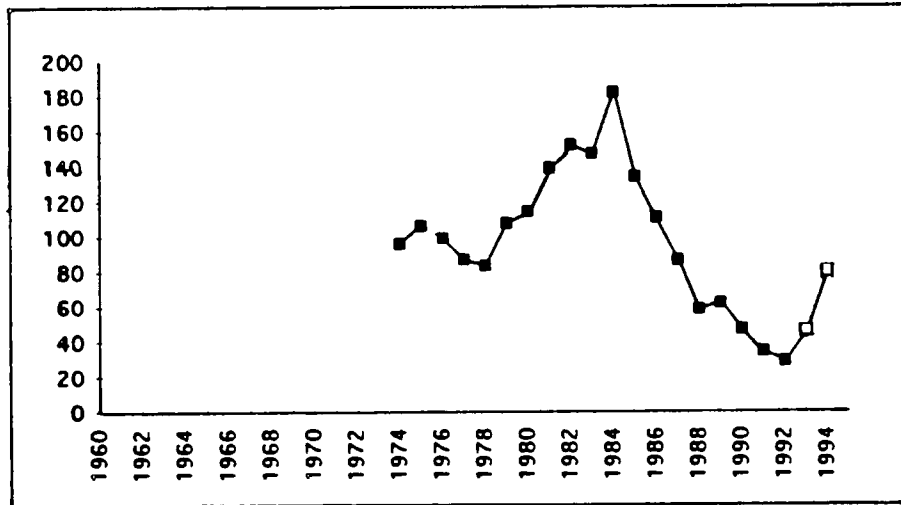

Fig. 1.3l. Fishing mortality rates.

(7-9)

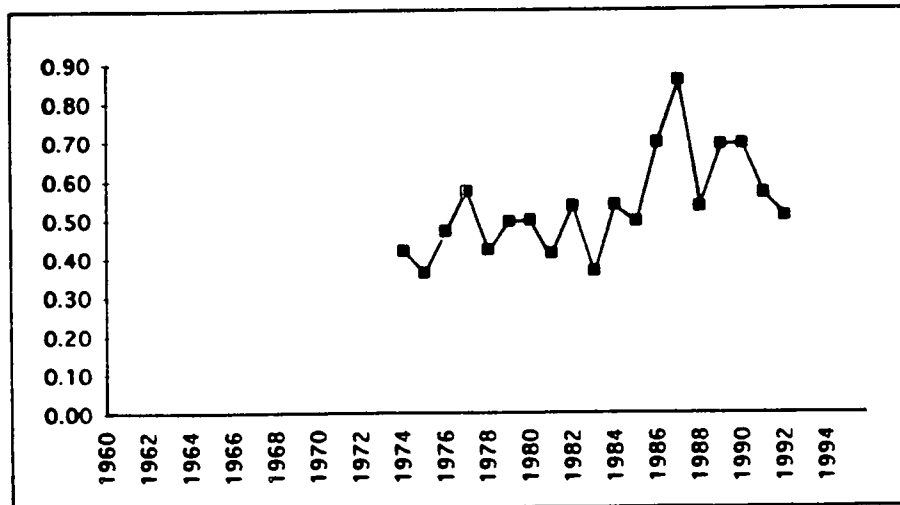
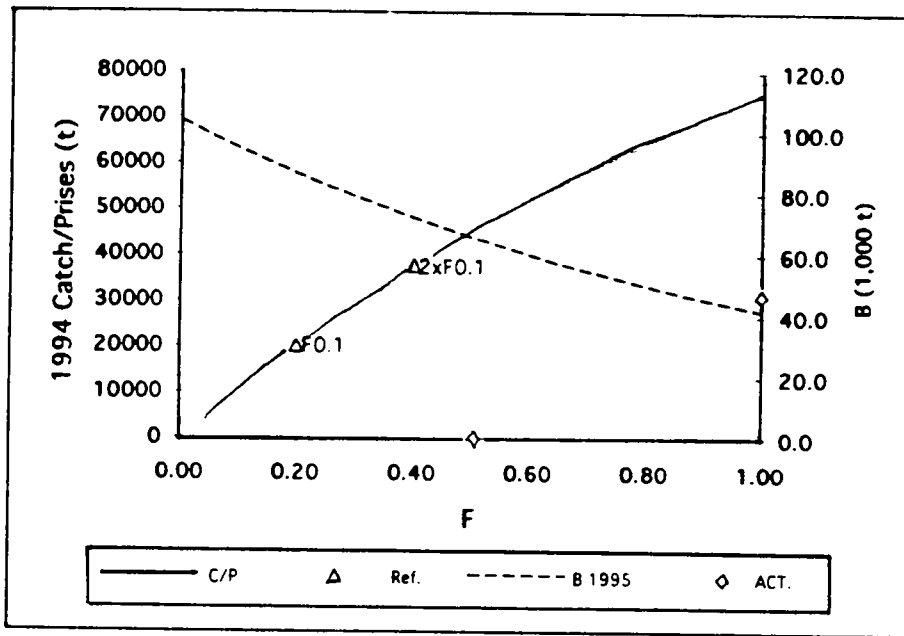

Fig. 1.3j. Cod - Morue: 3Pn-4RS

Projections



Cod in 4T-Vn (J.-A.)

Fig. 1 .4a Total catches (t) and TACs (t).

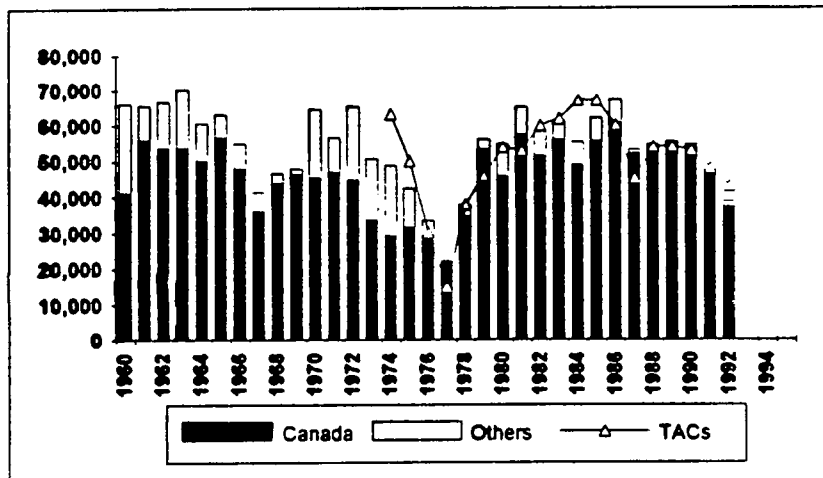
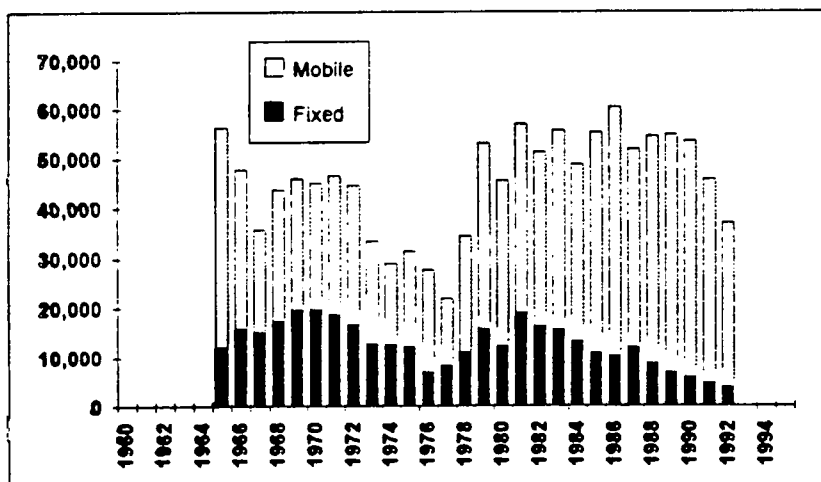

Fig. 1 .4b. Inshore and Offshore Canadian Catches (t)



Cod in 4T-Vn (J.-A.)

Abundance Indices

Fig. 1 .4c.

Mean Weight (kg)

at age 7

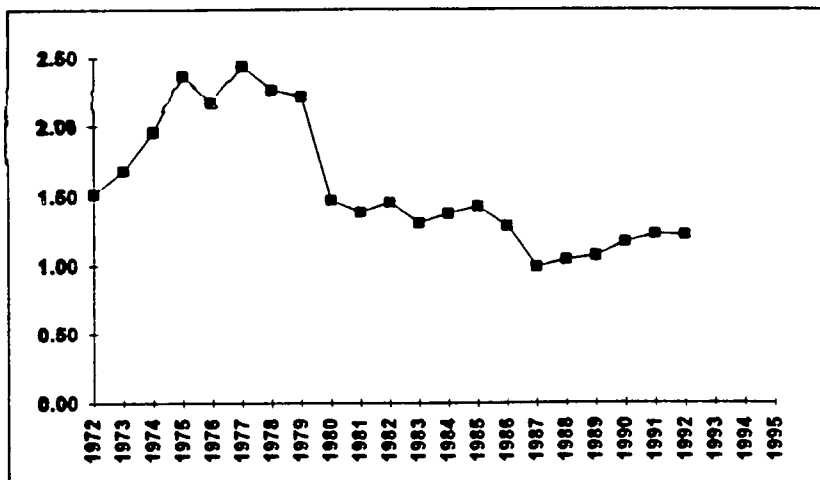
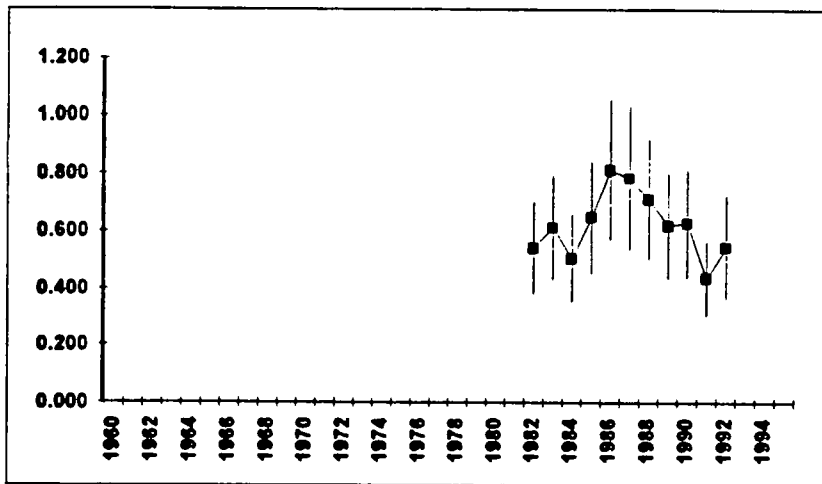

Fig. 1 .4d. OT CPUE (t/hour)



Cod in 4T-Vn (J.-A.)

Abundance Indices

Fig. 1 .4e. RV (Nb/tow) - fall

3+

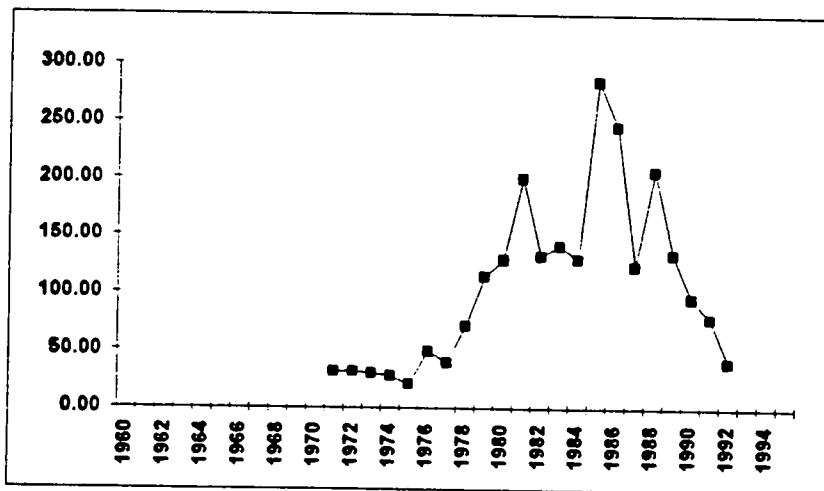

Fig. 1 .4f. RV (Nb/tow) - fall

5+

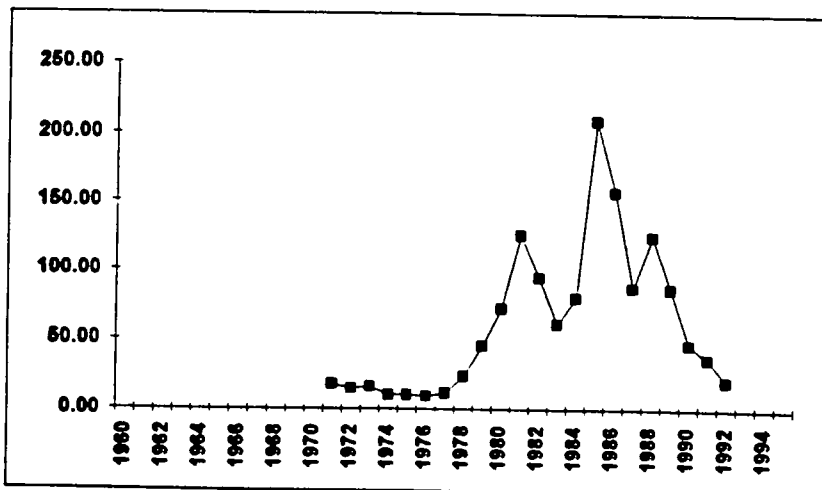
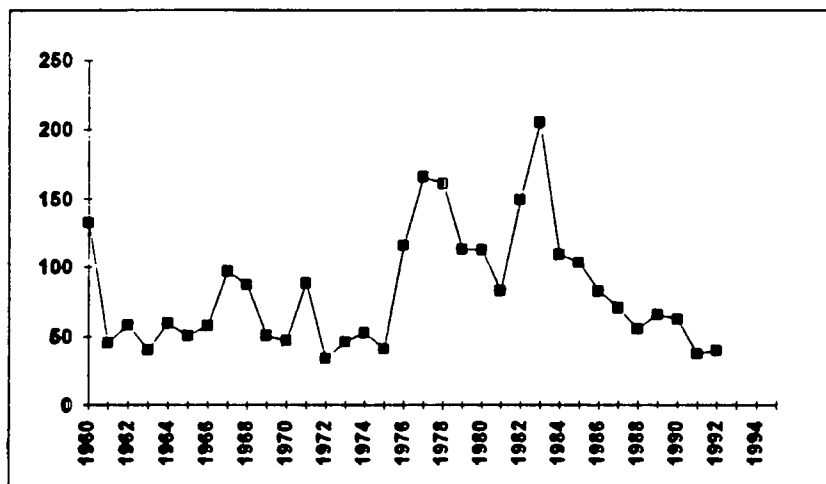

Fig. 1 .4g. Recruitment (million) Age 3



Cod in 4T-Vn (J.-A.) Hybrid

Fig. 1 .4h. Fishing mortality rates. 7+

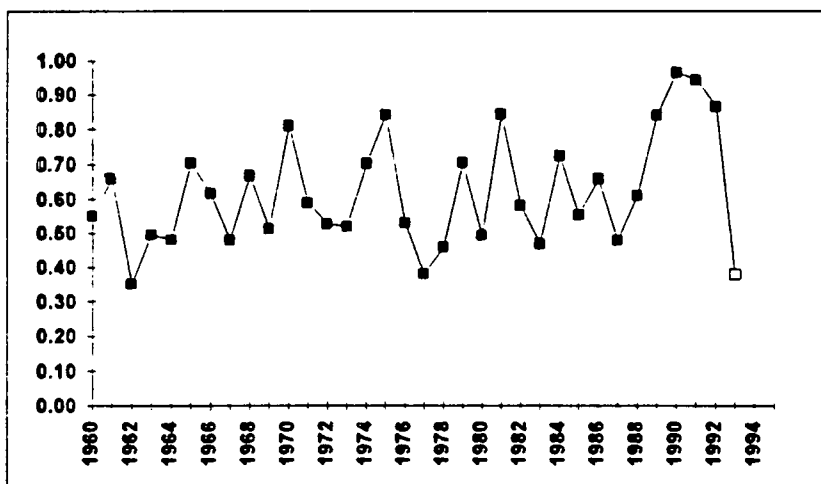
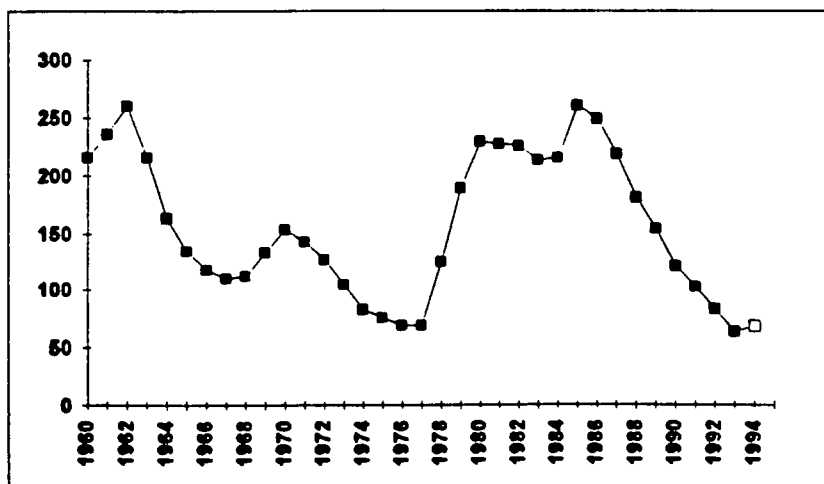

Fig. 1 .4i. Adult Biomass (thousand t) 6+



Cod in 4T-Vn (J.-A.)

Hybrid

Fig. 1 .4j.

Total Biomass (thousand t)

3+

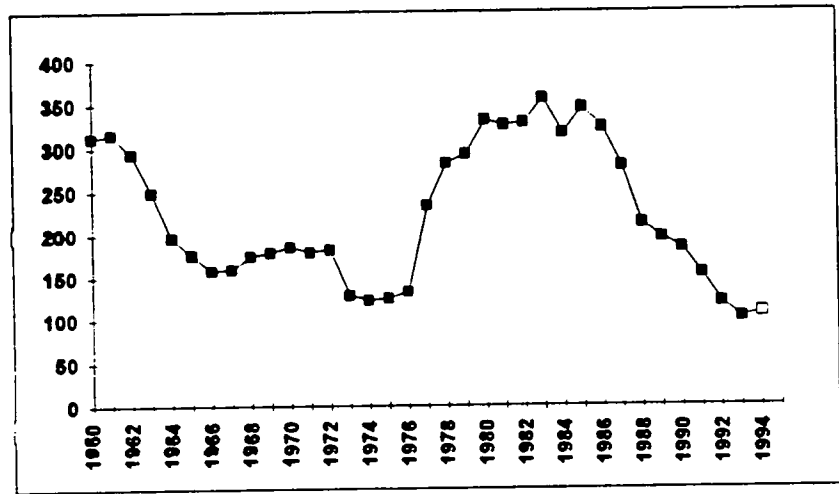

Cod in 4T-Vn (J.-A.)

Hybrid

Fig. 1 .4k.

Total Abundance (million)

3+

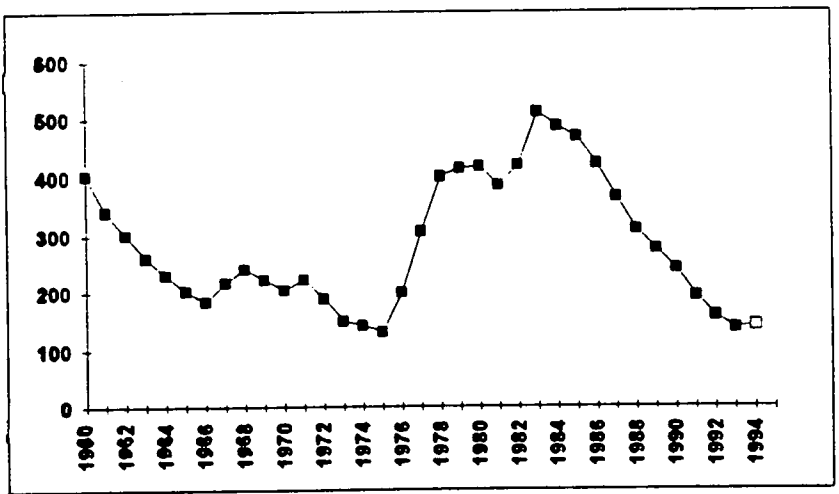
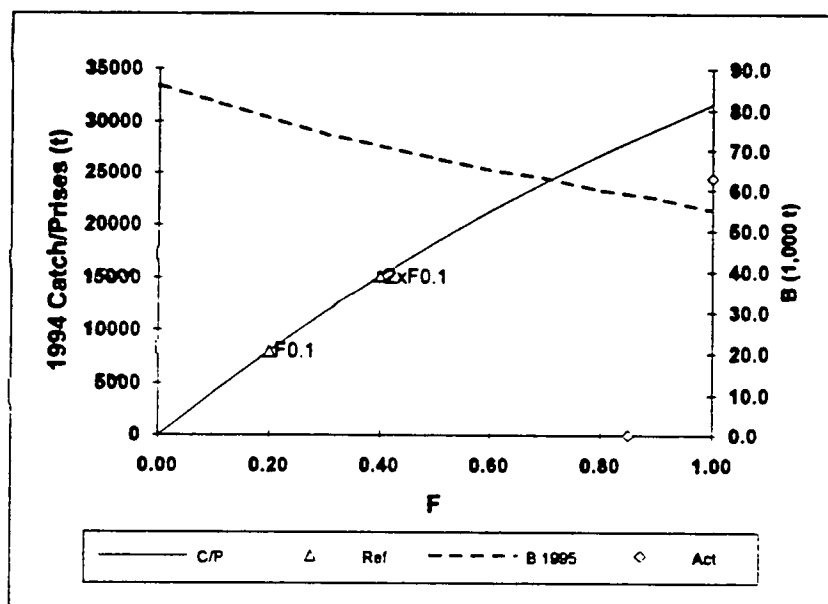

Fig. 1 .41.

Cod in 4T-4Vn(J.-A.)

Projections



C/P = Catch - Pnses

Ref. = Reference - Référence

B 1995 = Adult biomass at beginning of 1995 - Biomasse adulte au début de 1995

Act. = Actual - Actuel

F1992=

0.85



Cod in 4VsW

Fig. 1 .5a. Total catches (t) and TACs (t)

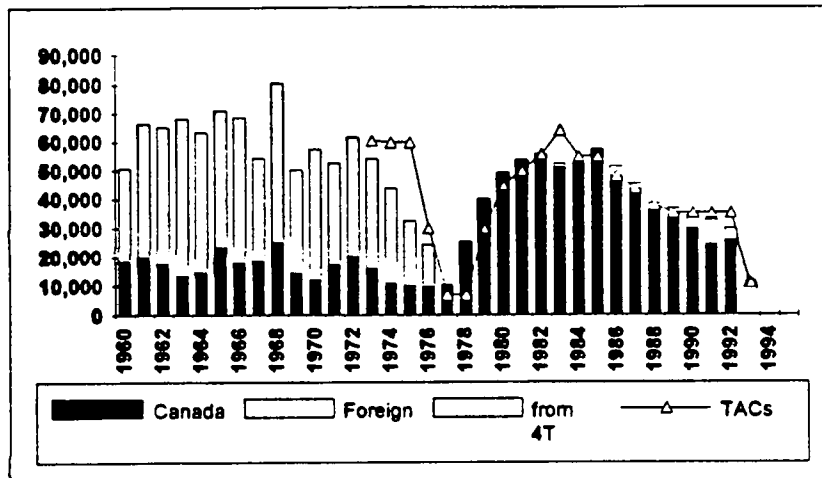
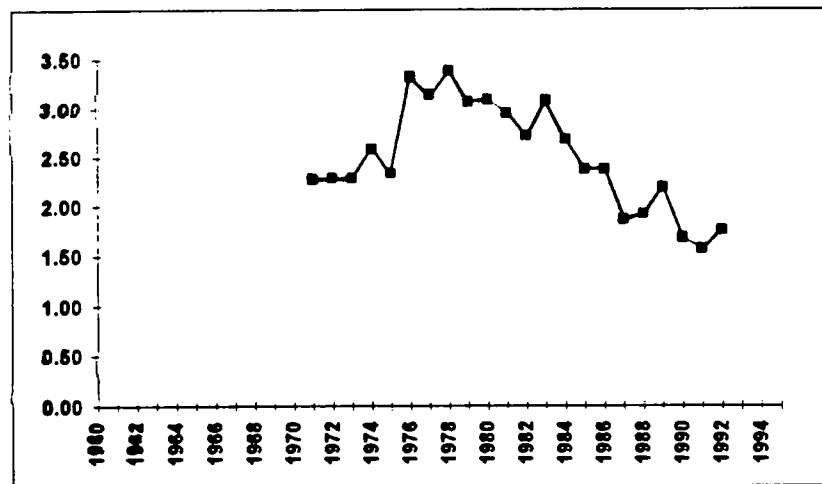

Fig. 1 .5b. Mean Weight (kg) at age 7



Cod in 4VsW

Abundance Indices

Fig. 1 .5c. CPUE (t/hour) - ZIF All ages

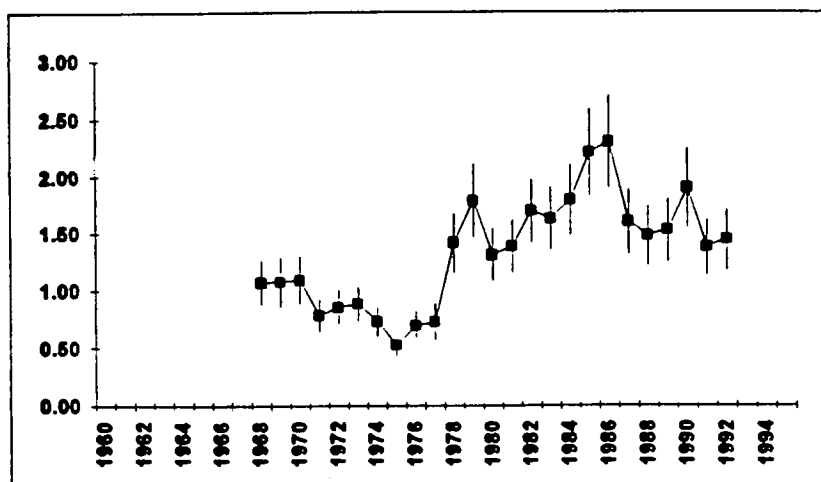

Fig. 1 .5d. CPUE (1/hour) - IOP All ages

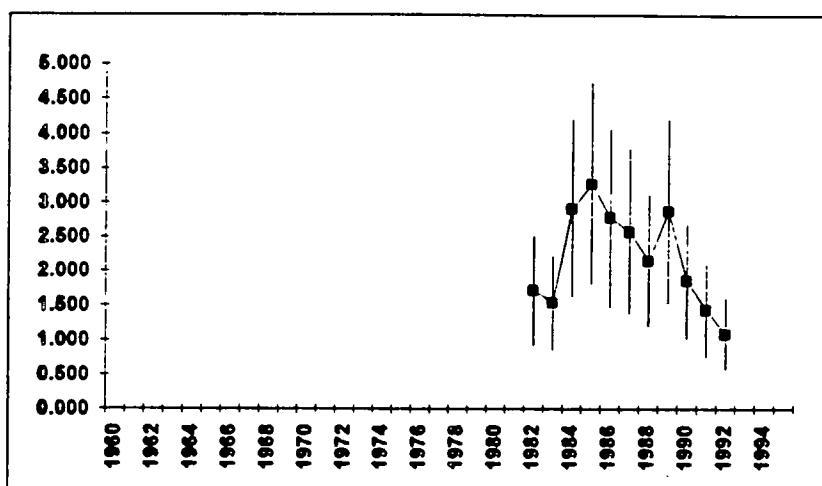

Fig. 1 .5e. Cod in 4VsW Abundance indices RV (#/tow) July 3+

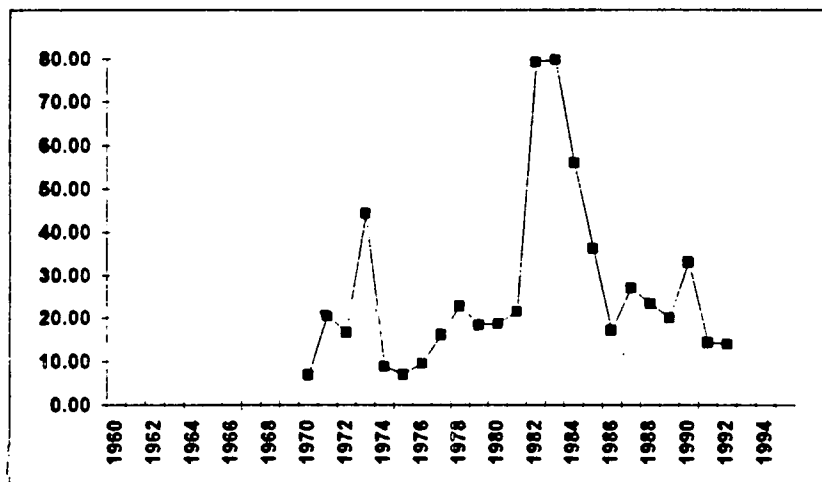
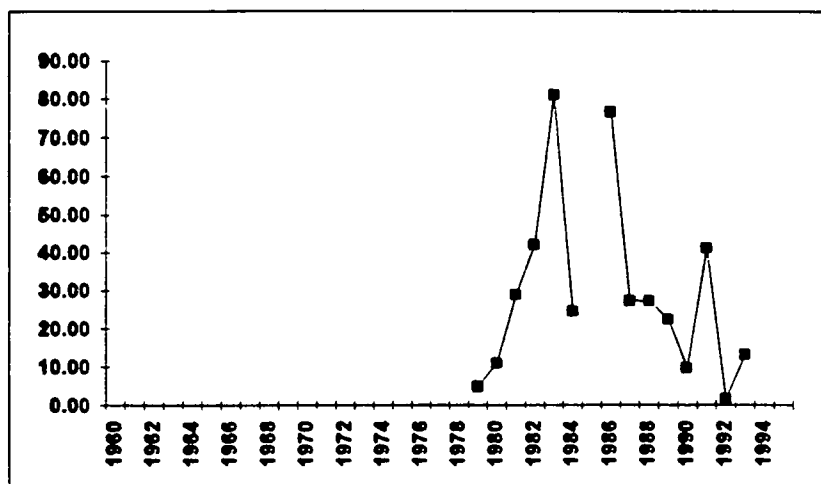

Fig. 1 .5f. RV (#/tow) Spring 3+



Cod in 4VsW

ADAPT

Fig. 1 .5g.

Fishing mortality rates.

7 to 9

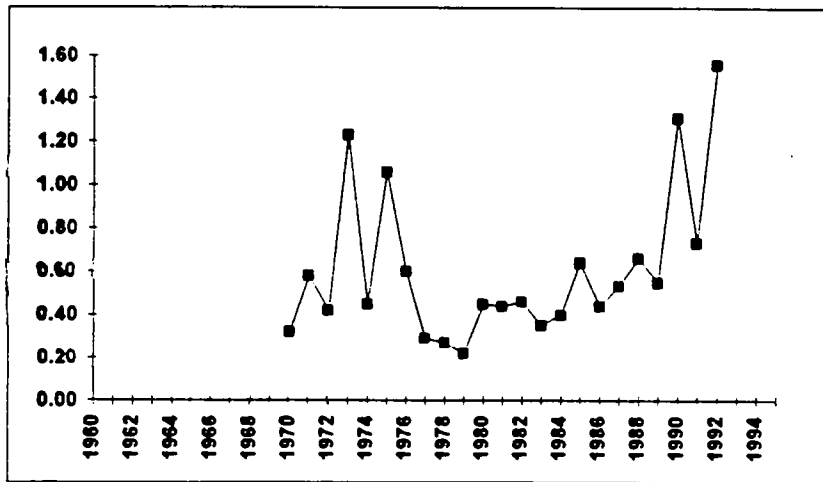

Cod in 4VsW

ADAPT

Fig. 1 .5h.

Total Biomass (thousand t)

1+

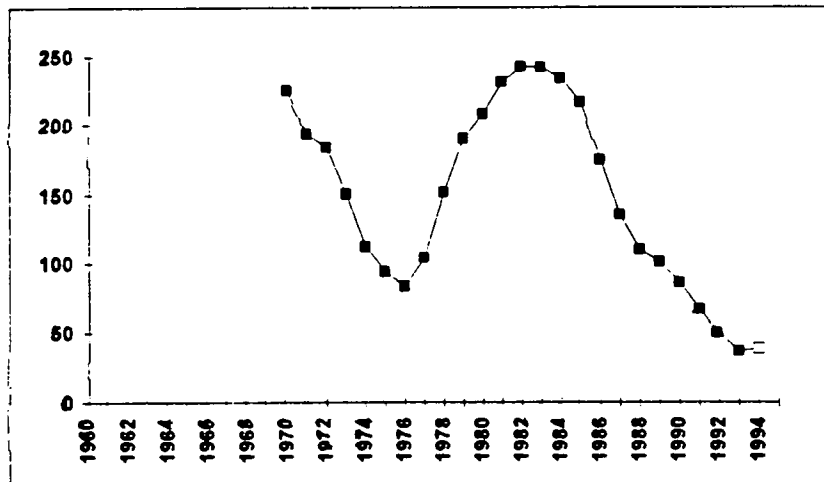

Fig. 1 .5i.

Adult Biomass (thousand t)

6+

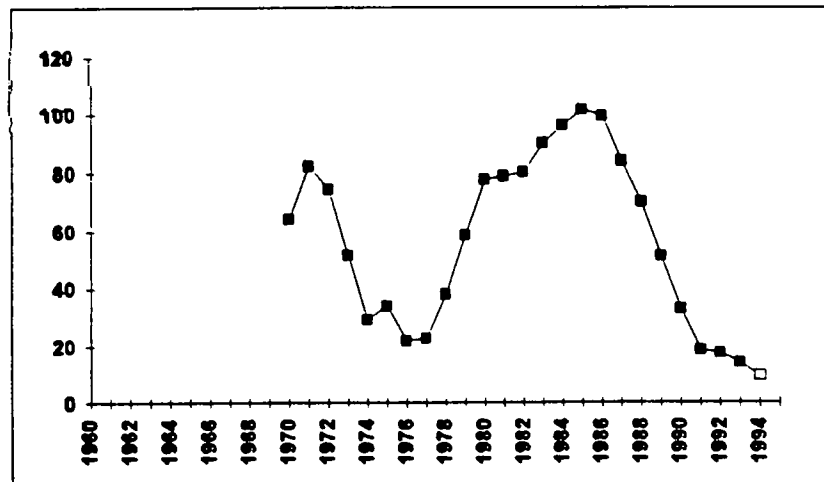



Fig. 1 .5k. 4VsW cod numbers 3-8 from SPA surveys.

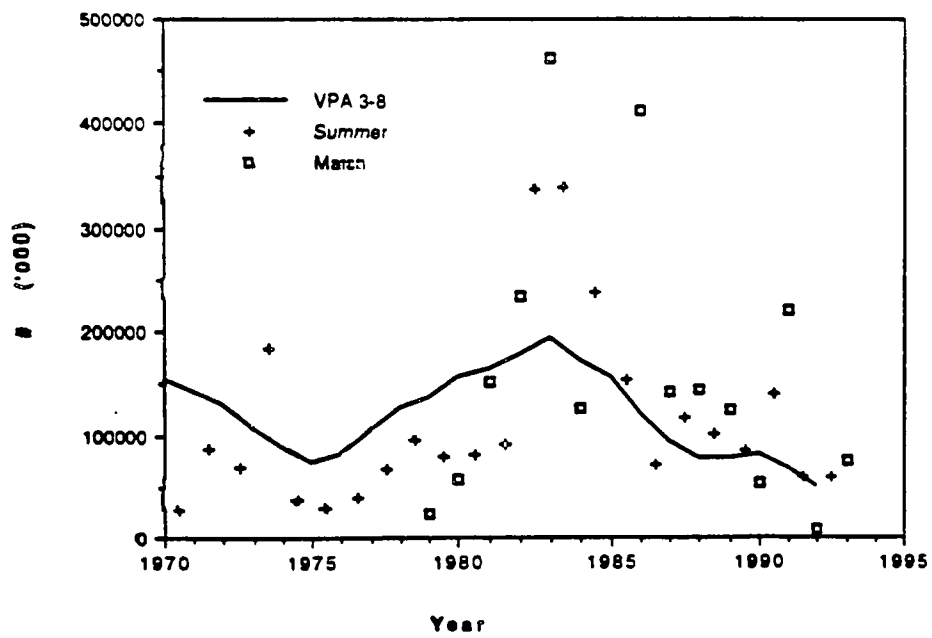
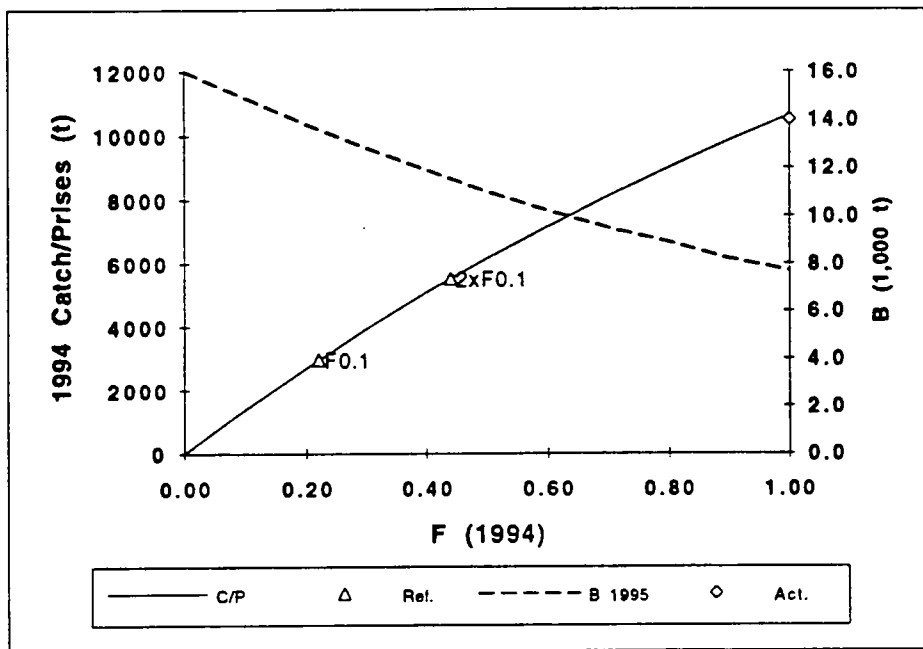

Fig. 1 .5l. Cod - Morue: 4VsW

Projections



C/P = Catch - Prises  
 Ref. = Reference - Référence  
 B 1995 = Adult biomass at beginning of 1995  
 Biomasse adulte au début de 1995  
 Act. = Actual - Actuel

Fig. 1 .5m. Long-term average vs. recent size frequencies from summer surveys.

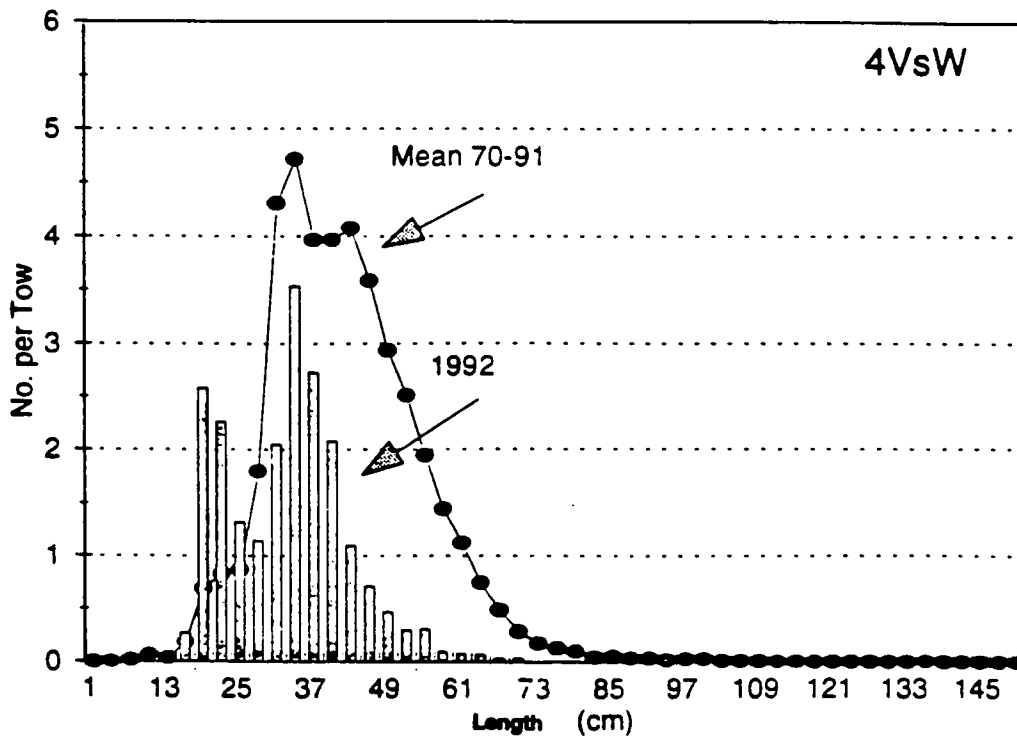
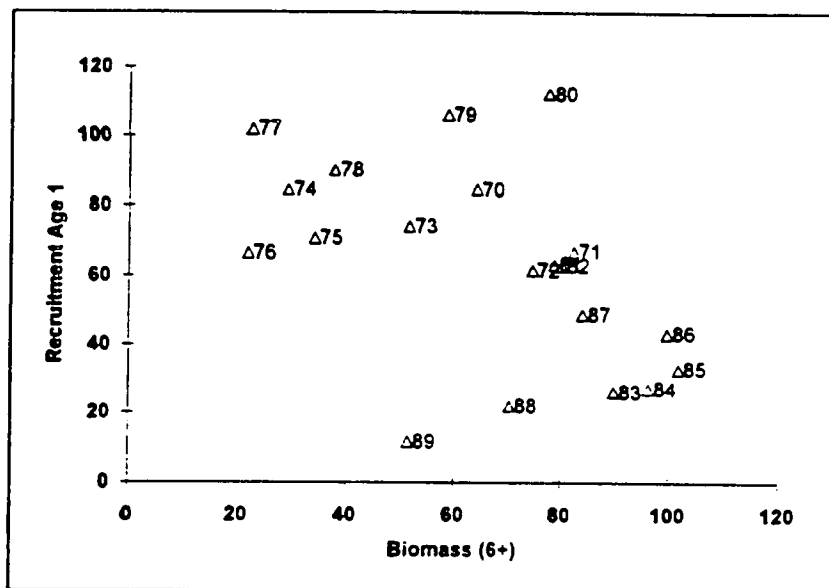

Fig. 1 .5n. Cod in 4VaW - recruitment and adult biomass.



Labels identify year-class.

Cod in 4X

Fig. 1 .6a. Total catches (t) and TACs (t)

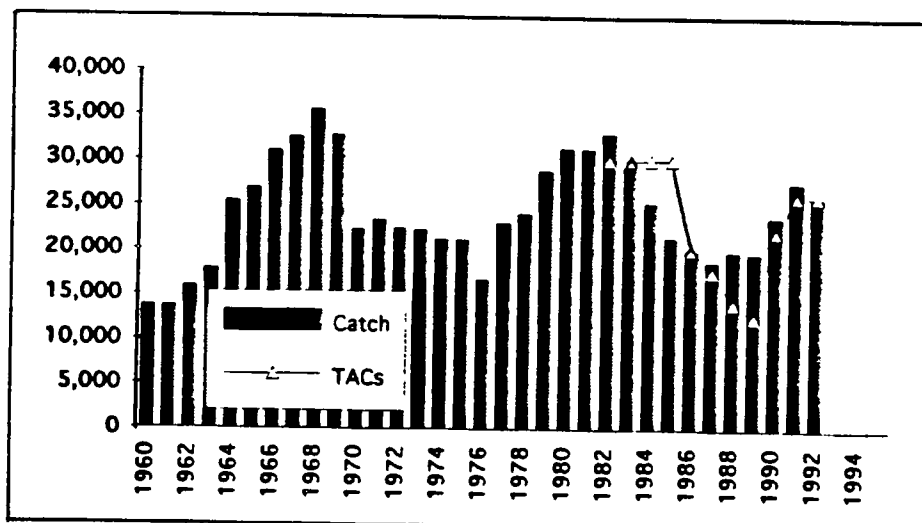

Fig. 1 .6b.

Cod in 4X

SPA and RV (k adjusted) numbers (million)

Age 3-10

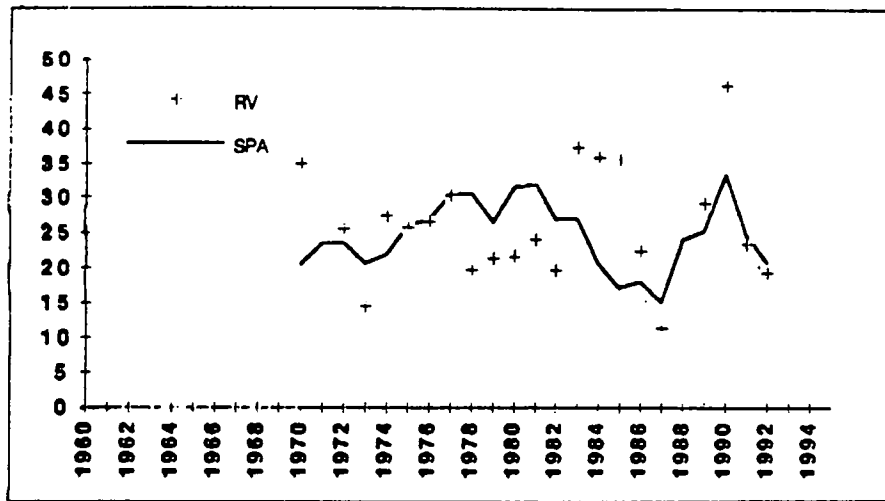

Fig. 1 .6c.

Cod in 4X

Total Biomass (thousand tonnes)

1+

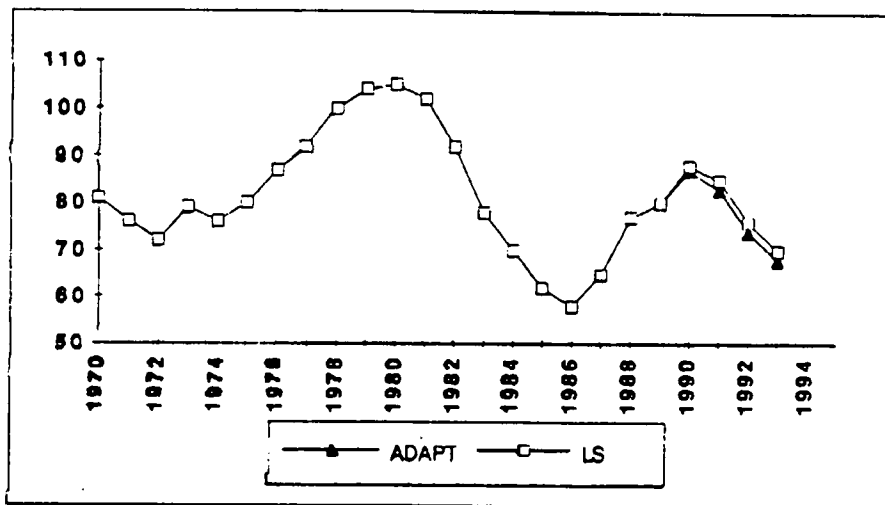

Fig. 1 .6d.

Recruitment (million)

Age 1

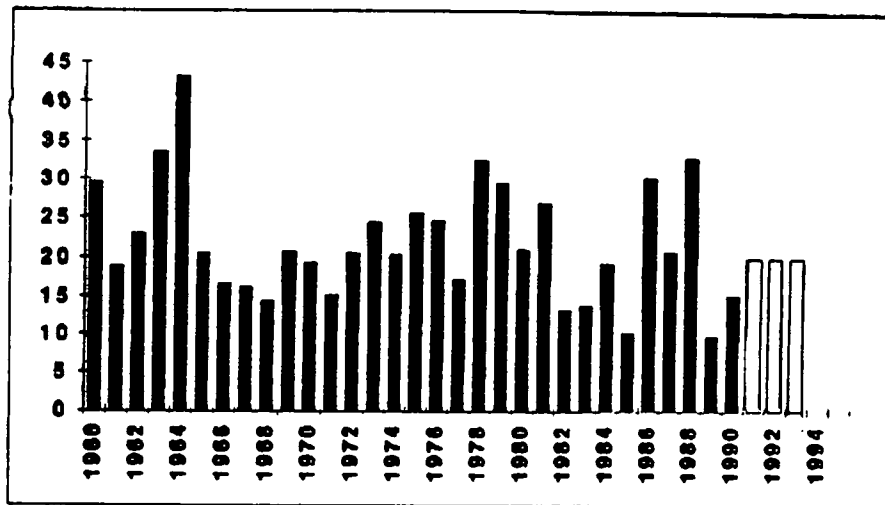

Fig. 1 .6a.

Cod in 4X

ADAPT

Total Biomass (thousand tonnes)

1+

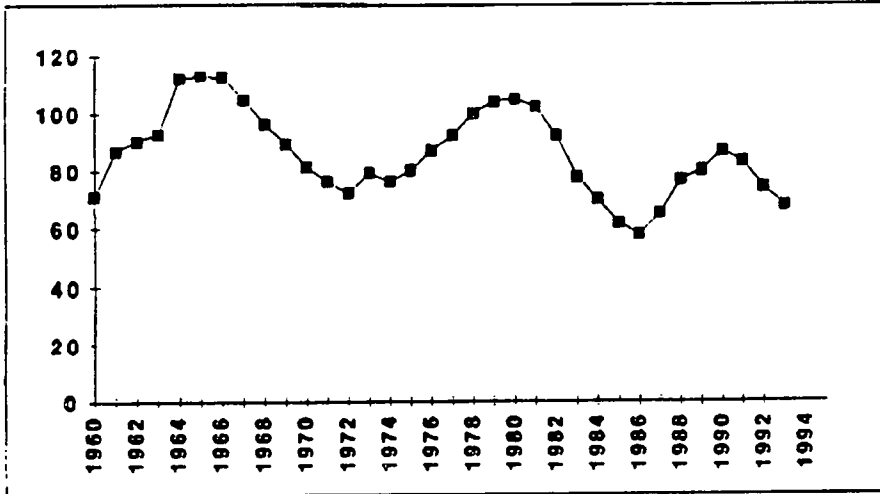

Spawning Biomass (thousand tonnes)

3+

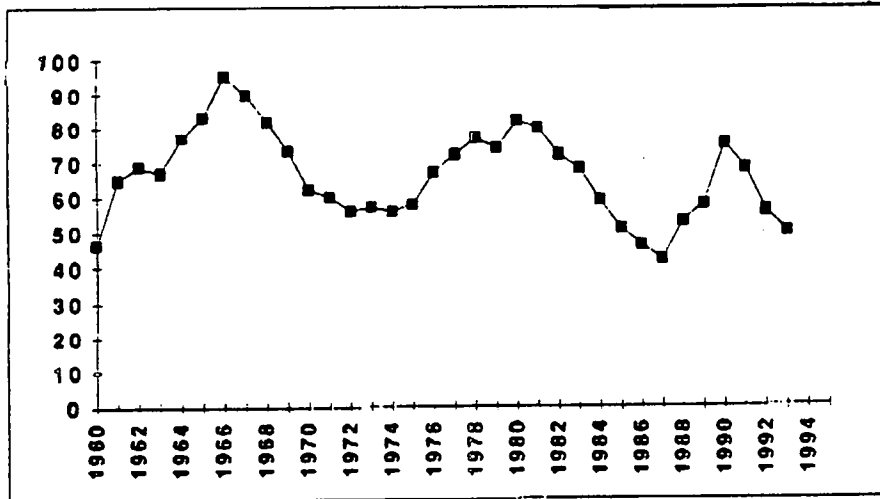

Fig. 1 .6f.

Annual exploitation rates.

(4-6)

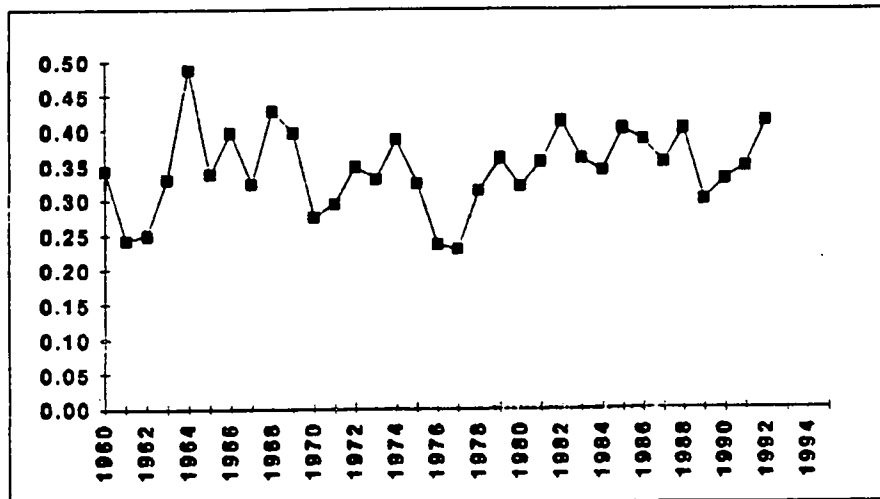



Fig. 1 .6g.

Cod In 4X

Projections

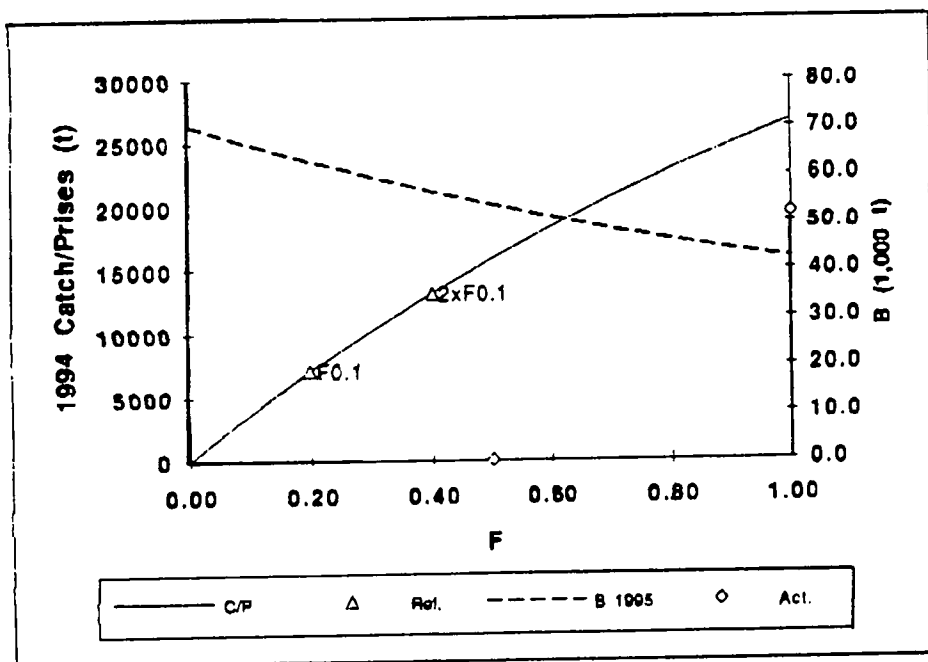
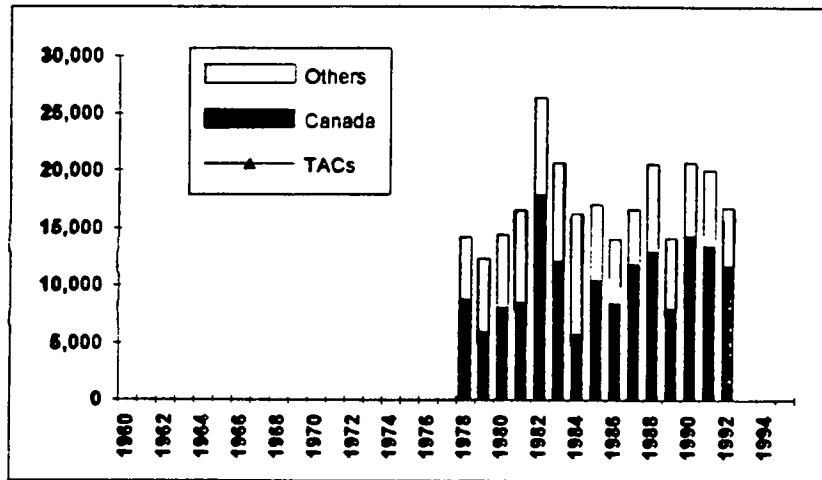

Fig. 1 .7a. Total catches (t) and TACs (t)



Cod in 5Zj,m

Fig. 1 .7b. Research vessel indices.

U.S.A. spring (nb/tow)

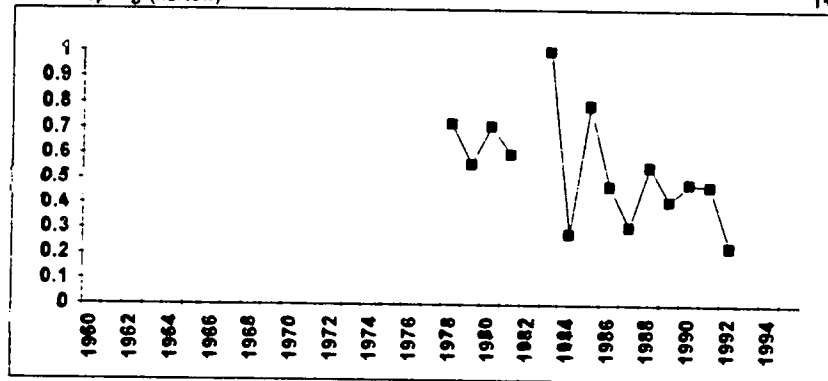

U.S.A. fall (nb/tow)

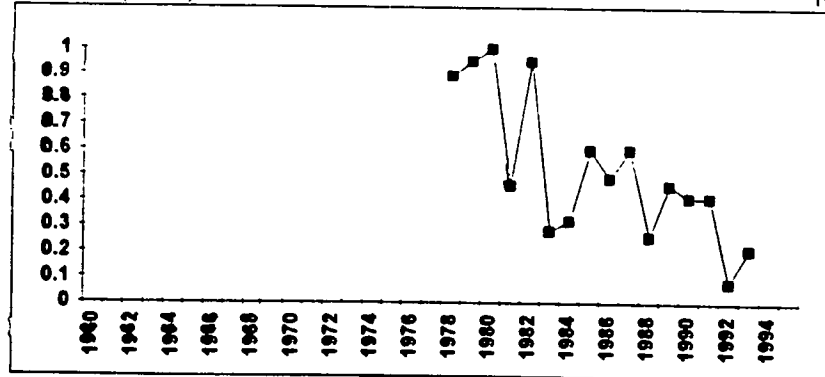

Canadian RV (nb/tow)

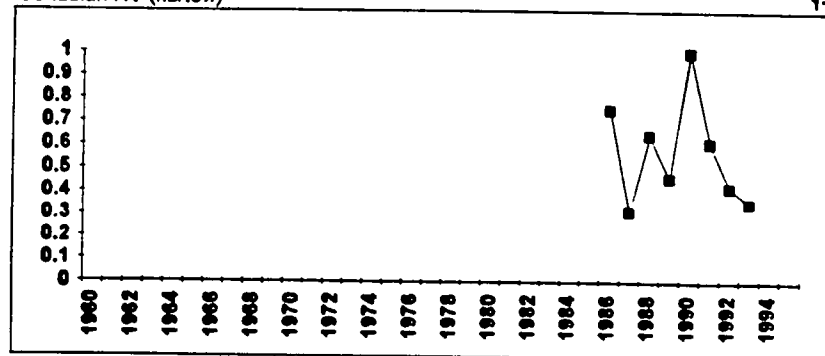

## Haddock in 4TVW

Fig. 1 .8a. Total catches (t) and TACs (t)

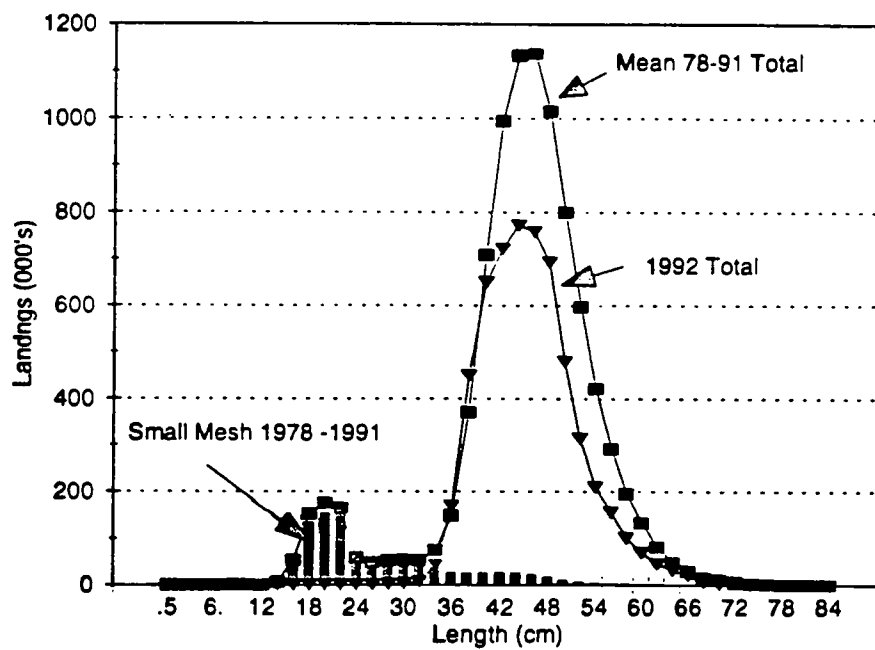
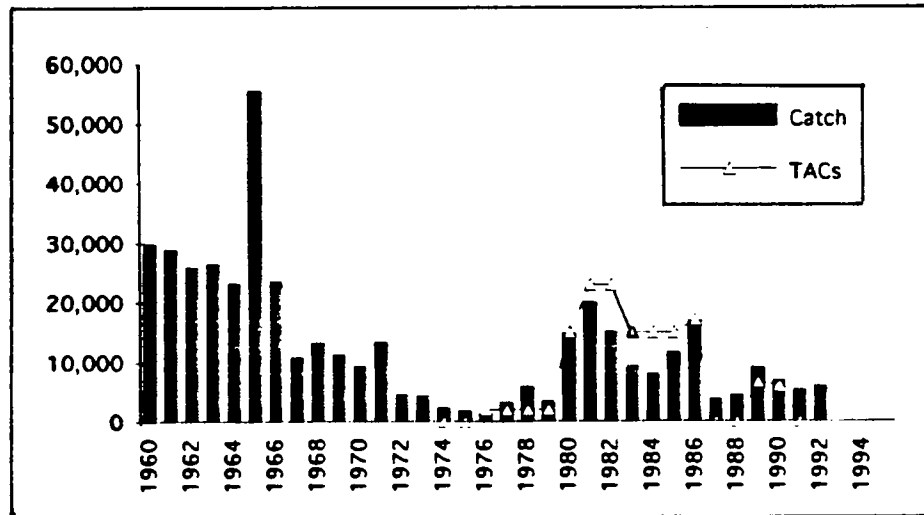

Fig. 1 .8b. 4TVW haddock. Catch at length (In 000's of fish) for the domestic and foreign small mesh fisheries on 4TVW haddock for the periods 1978-1991, and 1992.

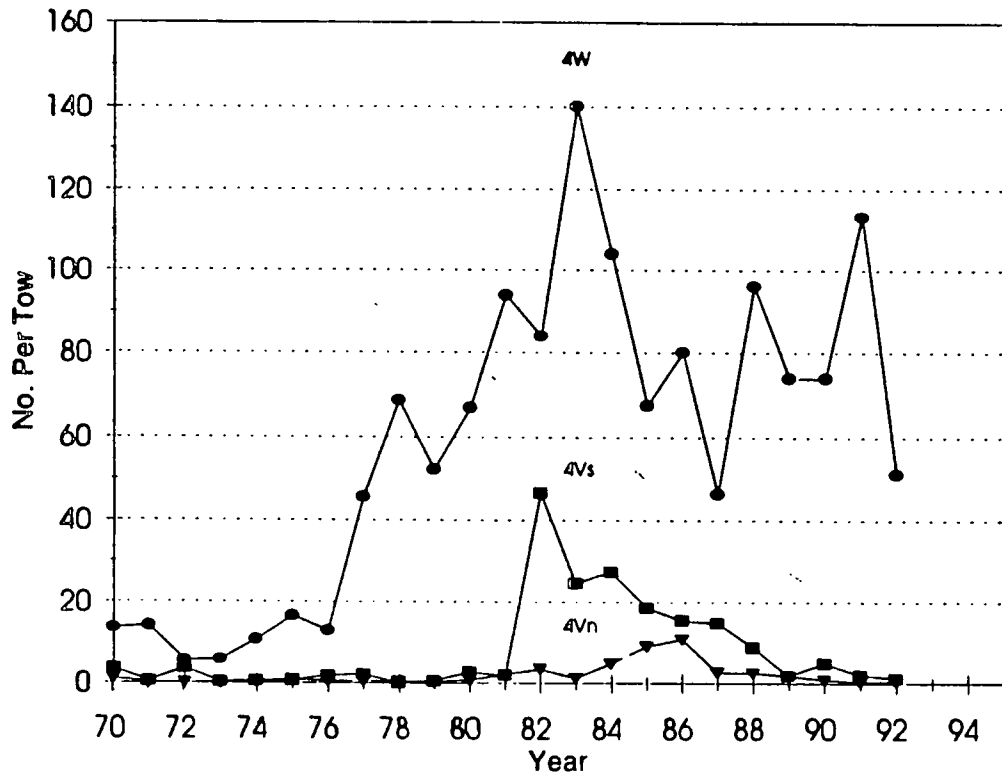

Fig. 1 .8c. 4TVW haddock. Summer research vessel catch rates for 4TVW haddock 1970-1992.

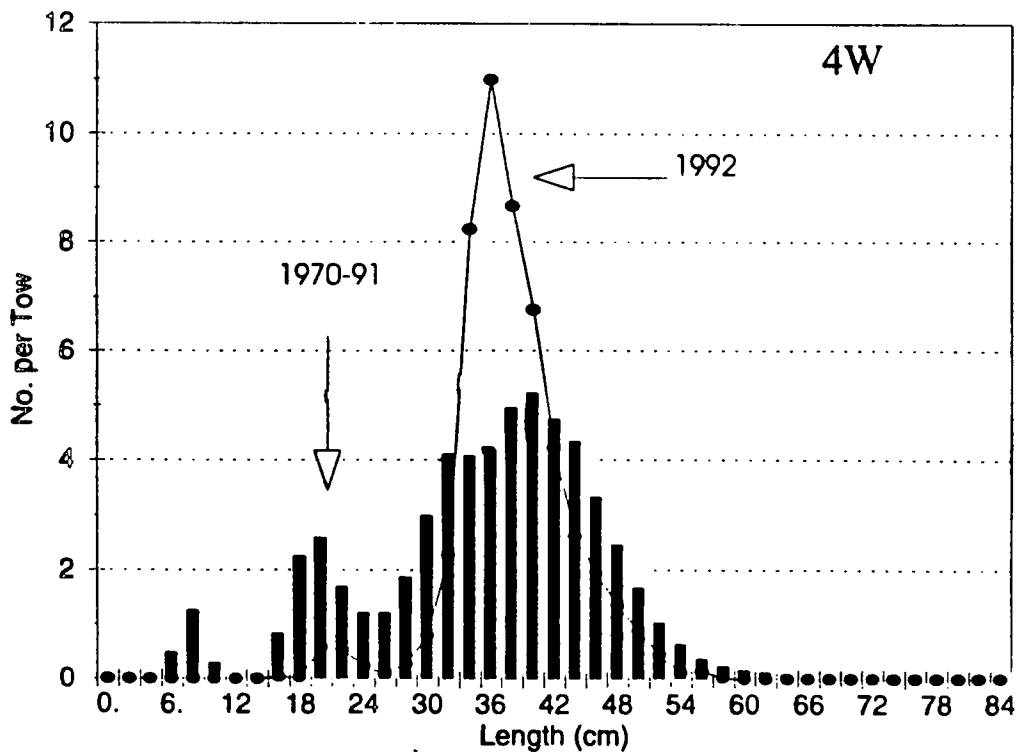

Fig. 1 .8d. 4W haddock. Mean catch rates at length from summer surveys in Subdivision 4W for the years 1970-1991 (bars) and 1992 (line).

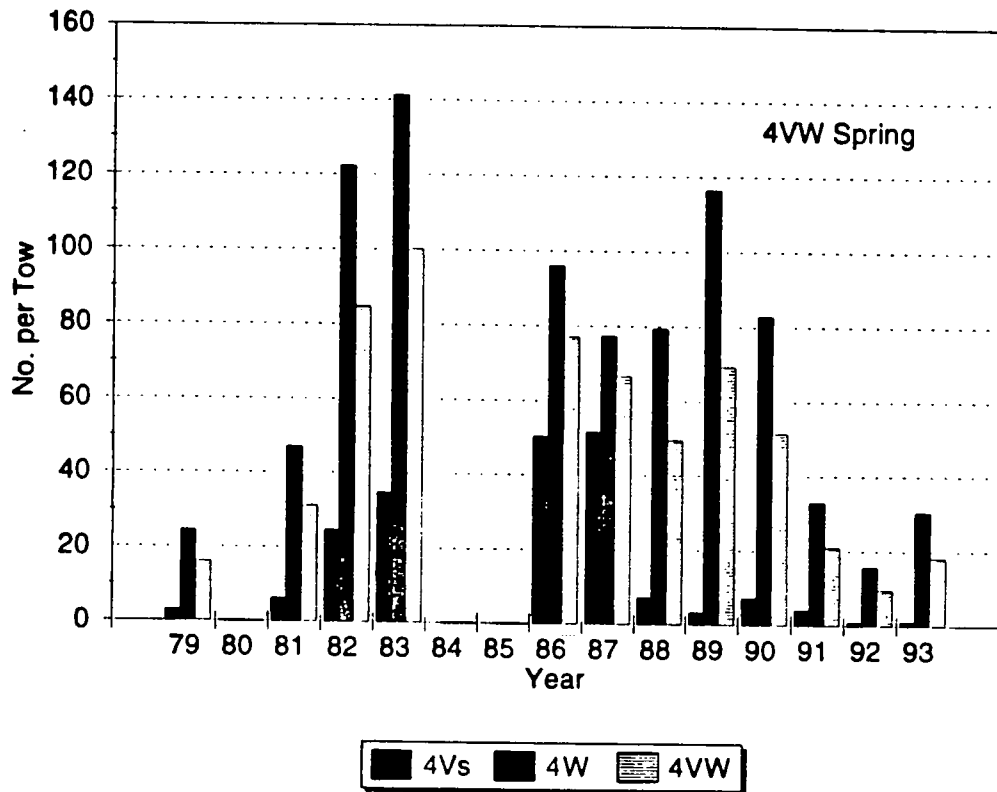

Fig. 1 .8e. 4VW haddock. Catch rates from spring surveys (March) in 4VW for the period 1979 to 1993.

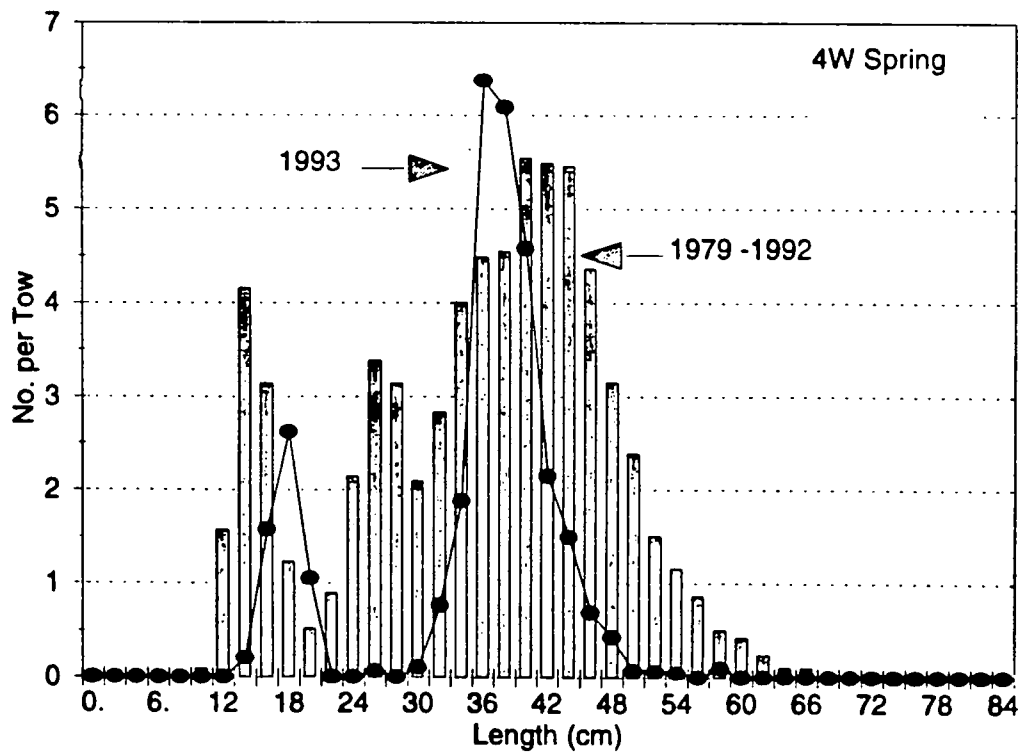

Fig. 1 .8f. 4W haddock. Catch rates at length from spring surveys conducted in Division 4W for the period 1979-1992 (bars) and 1993 (lines).

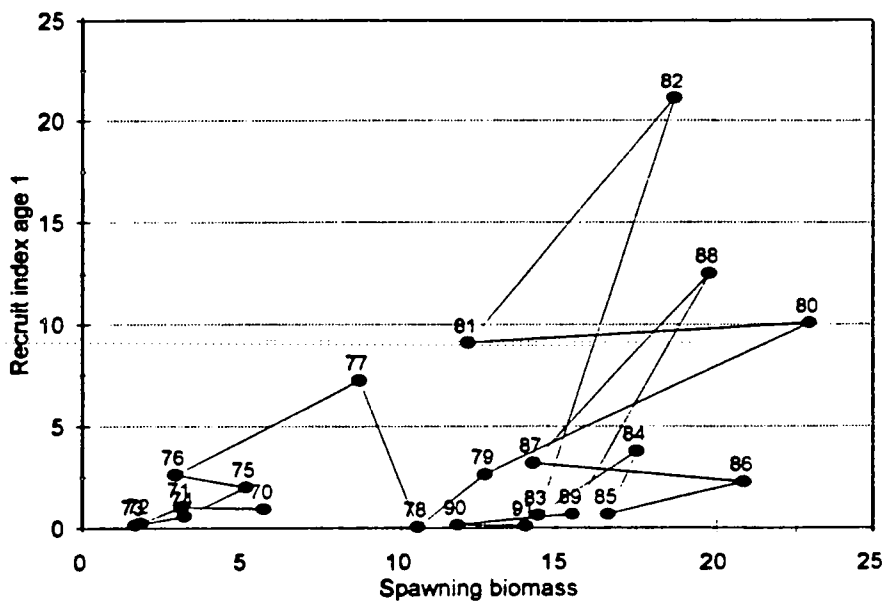

Fig. 1 .8g. 4TVW haddock. Relationship between recruitment and spawning stock biomass.

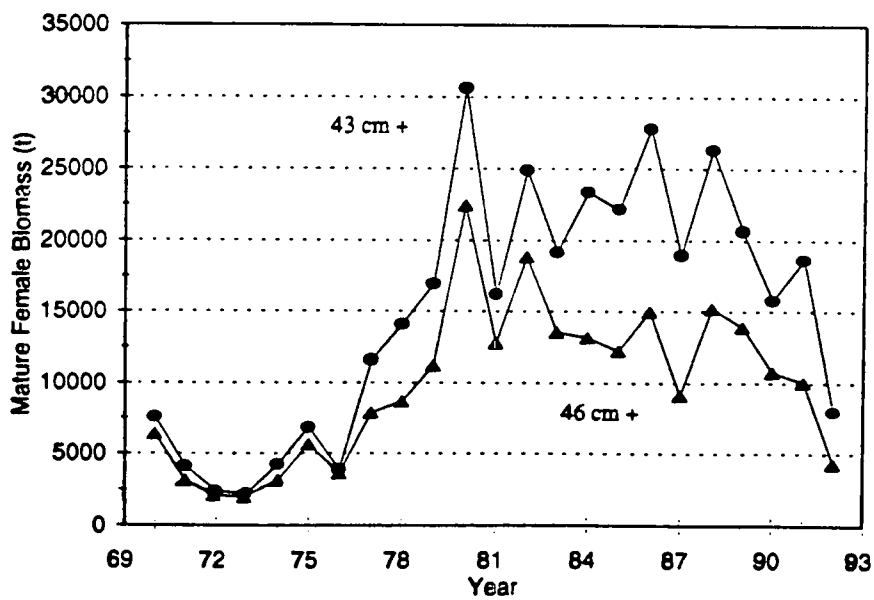

Fig. 1 .8h. Summer survey estimates of mature female haddock biomass in 4VW from 1970-1992 assuming knife-edged maturation at either 43 cm or 46 cm.

Fig. 10.9a. Total catches (t) and TACs (t).

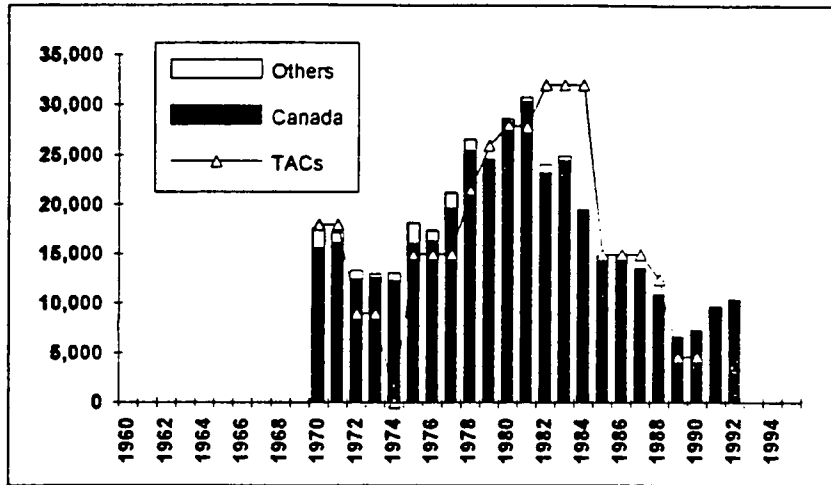

Fig. 1 .9b. Fixed and Mobile Canadian Catches (t).

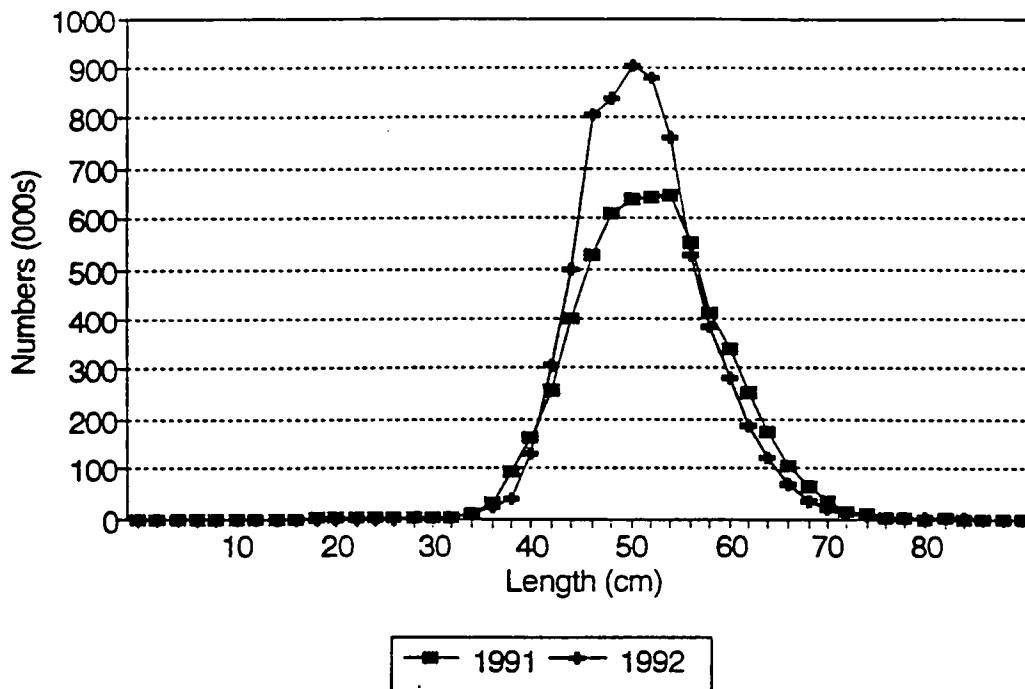
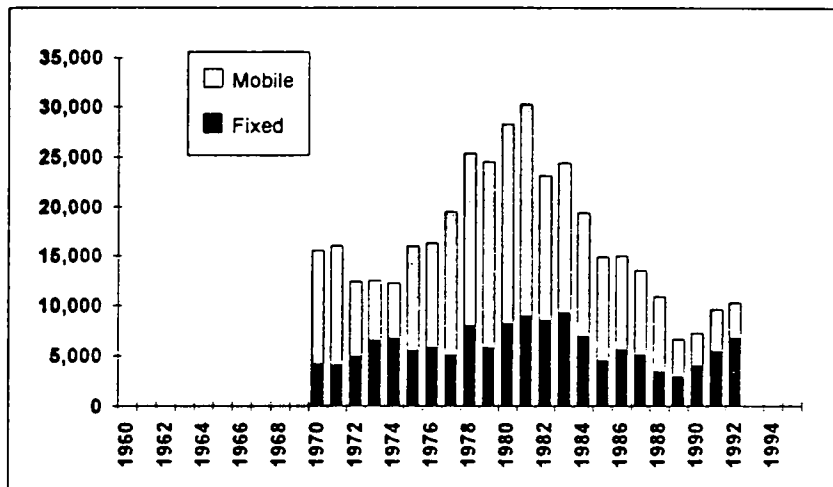

Fig. 1 .9c. 4X haddock. Catch at length in 1991 and 1992.

Haddock in 4X

Abundance Indices

Fig. 1 .9d. CPUE.

1/1000 hooks

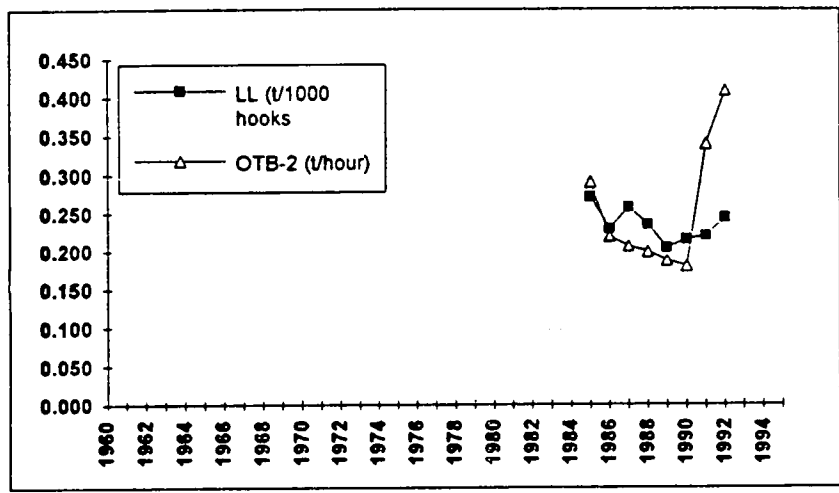

Haddock in 4X

Abundance Indices

Fig. 1 .9e.

RV (kg/tow)

<43 cm

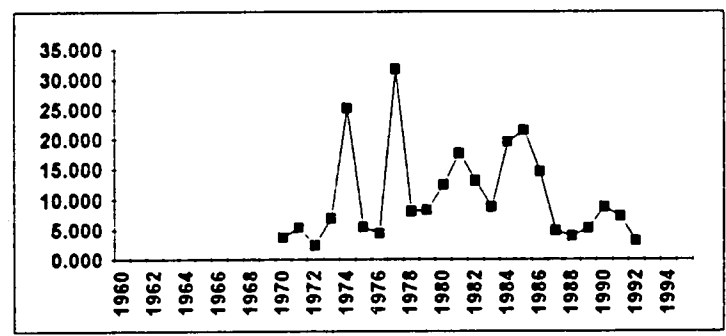

>43 cm

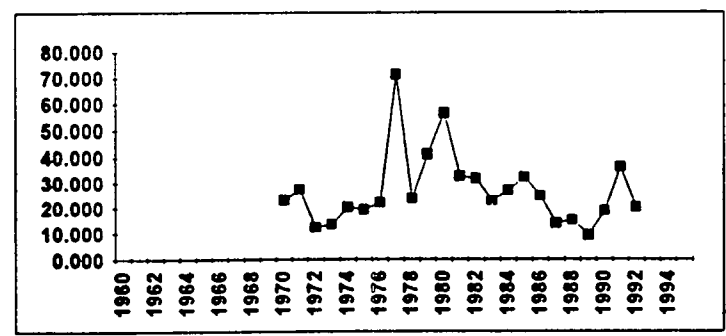

Total

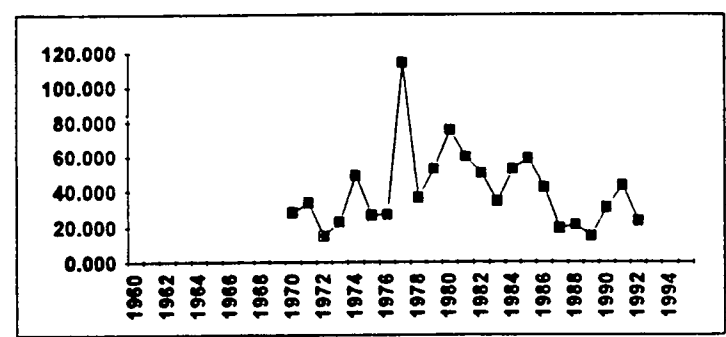



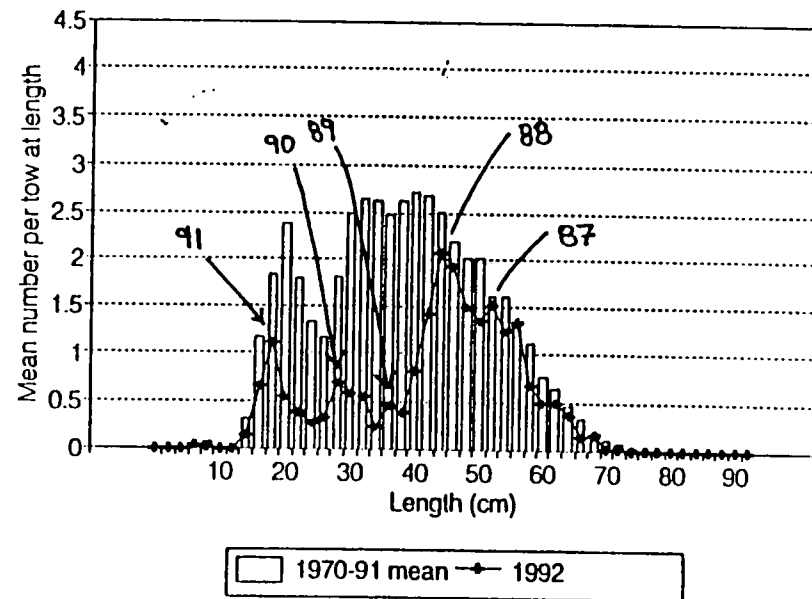
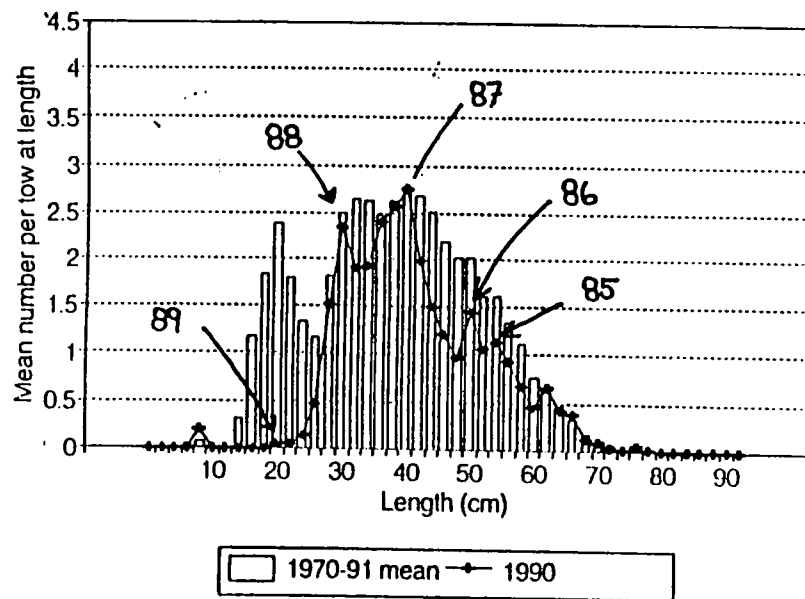
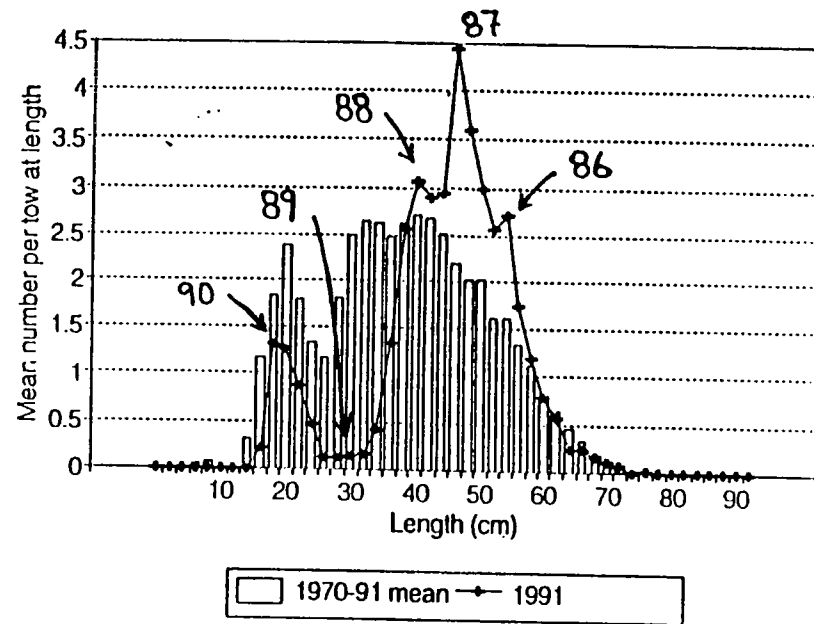
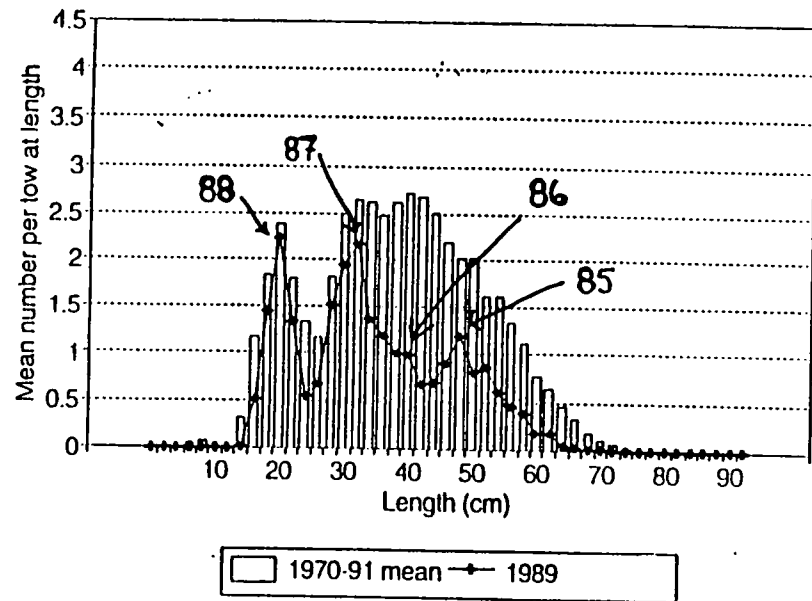

Fig. 1 .81. 4X haddock. Research vessel catch at length for 1989, 1990, 1991 and 1992 vs. the mean catch at length for 1970-1991.

Haddock in 4X

Abundance Indices

Fig. 1-9g. RV (recruitment index).

1+2

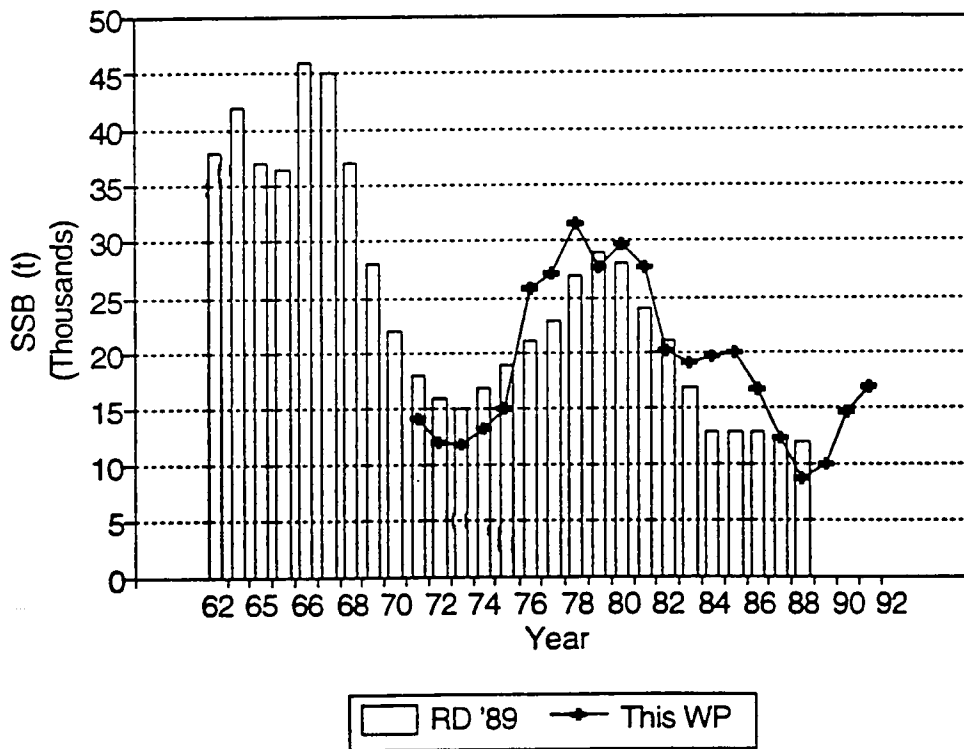
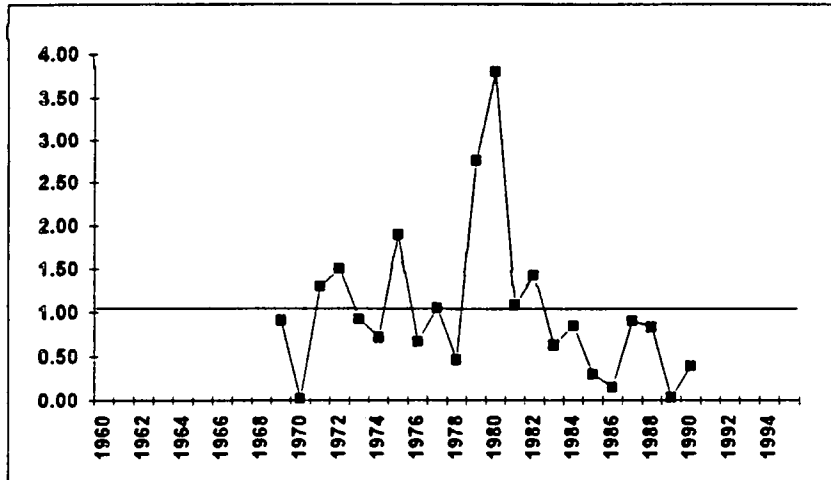

Fig. 1 .9h. 4X haddock. Trends in spawning stock biomass for 1962-88 (from O'Boyle et al 1989) and 1970-92 spawning stock biomass (3 year mean) calculated from research vessel mean numbers at length.

Haddock in 5Zj,m

Fig. 1 .10a. Total catches (t) and TACs (t)

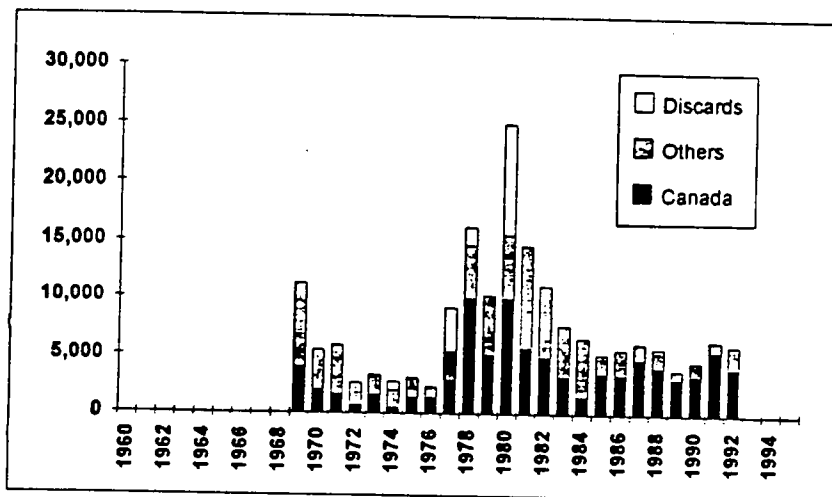
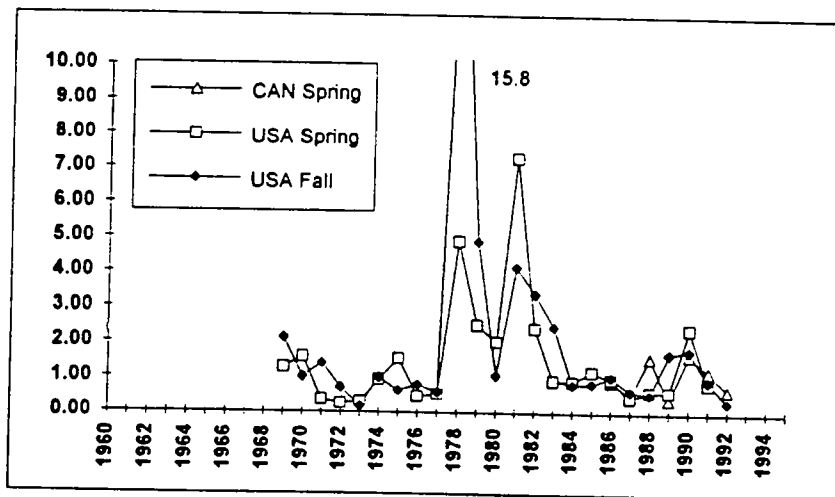
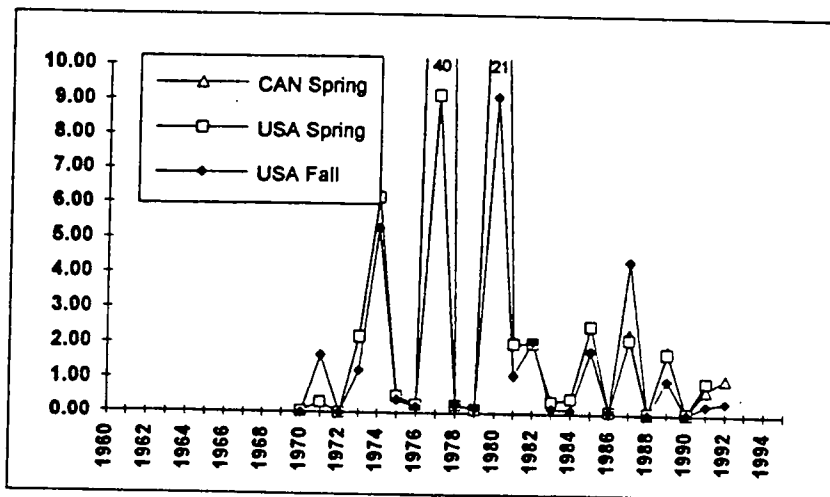

Fig. 1 .10b Abundance Indices Haddock in 5Zj,m

RV (#) Ages 3-8



RV (#) Ages 1-2



Haddock in 6Zj,m

Abundance Indices

Fig. 1.10c

CPUE and Effort

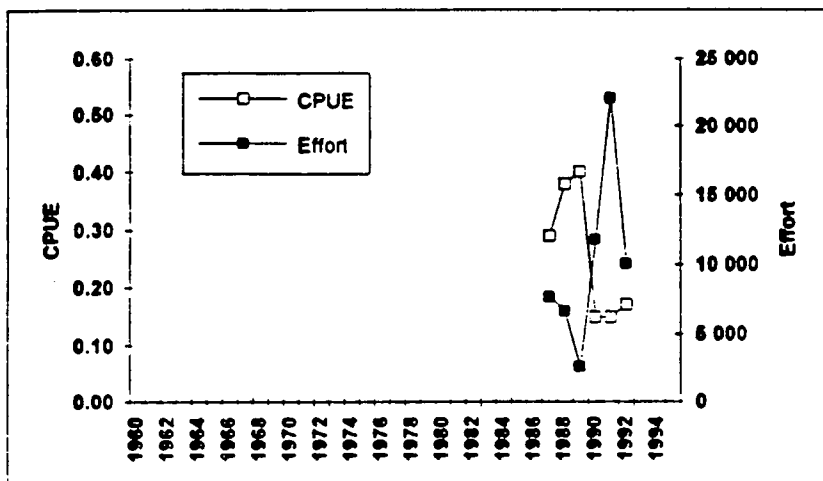

Haddock in 5Zj,m

Fig. 1.10d.

Biomass 3+ ('000t)

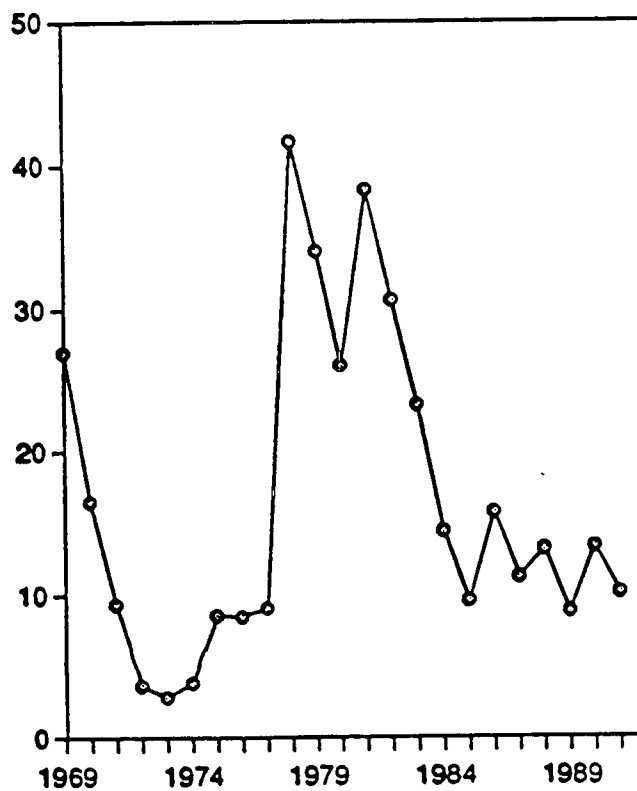

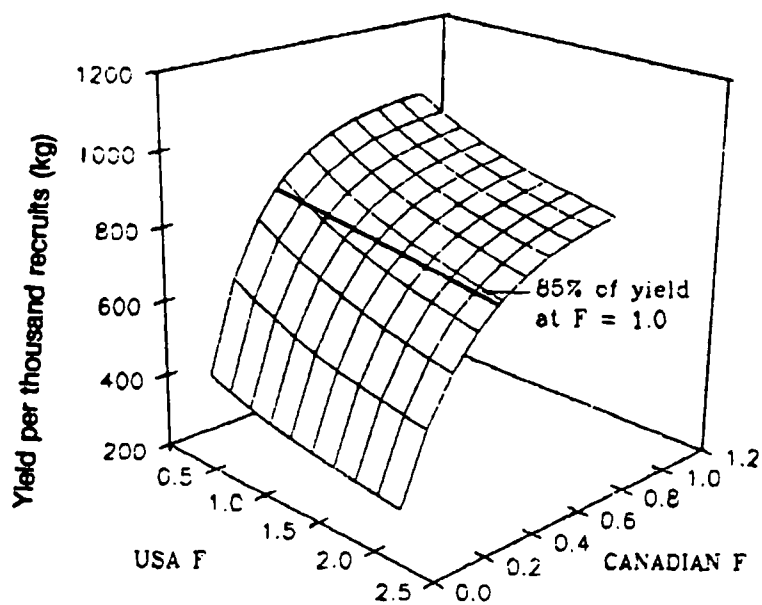
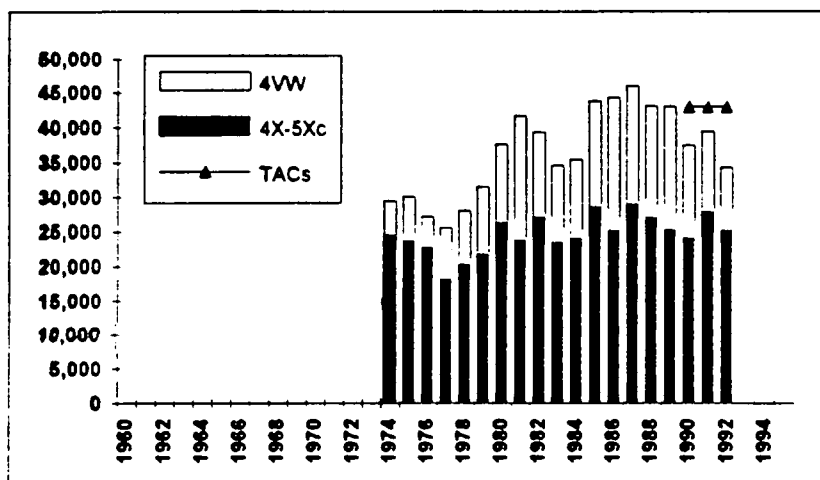

Fig. 1.10e. Yield to the Canadian fishery per thousand recruits.  
Exploitation expressed as instantaneous fishing mortality rate  
relative to population abundance in each respective territory.

Pollock in 4VWX+5

Fig. 1 .11a. Total catches (t) and TACs (t)



Pollock in 4VWX+5

Abundance Indices

Fig. 1 .11b.

TC-2 in 4X (ZIF)

All ages

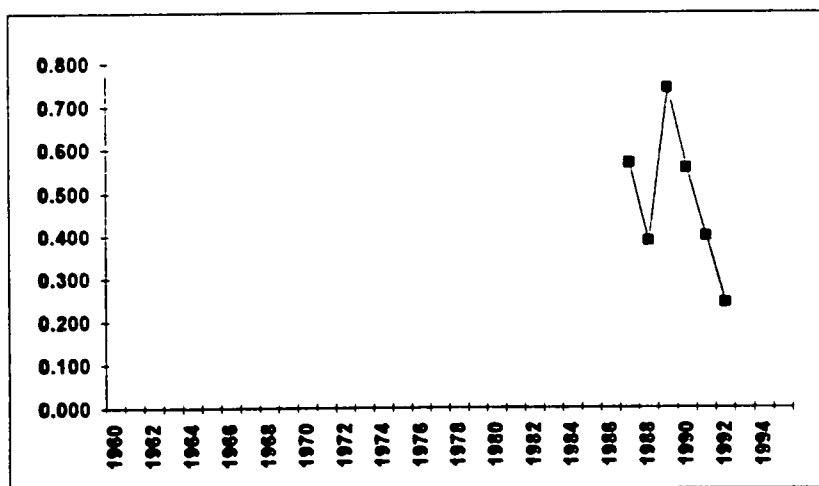
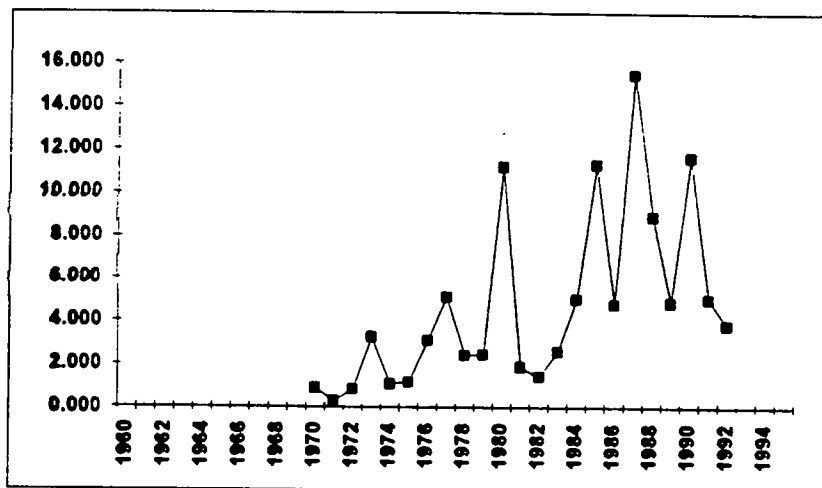

Fig. 1 .11c.

RV (#tow) - July

4-10



Pollock in 4VWX+5

ADAPT

Fig. 1 .11d.

Annual fishing mortality.

7-9

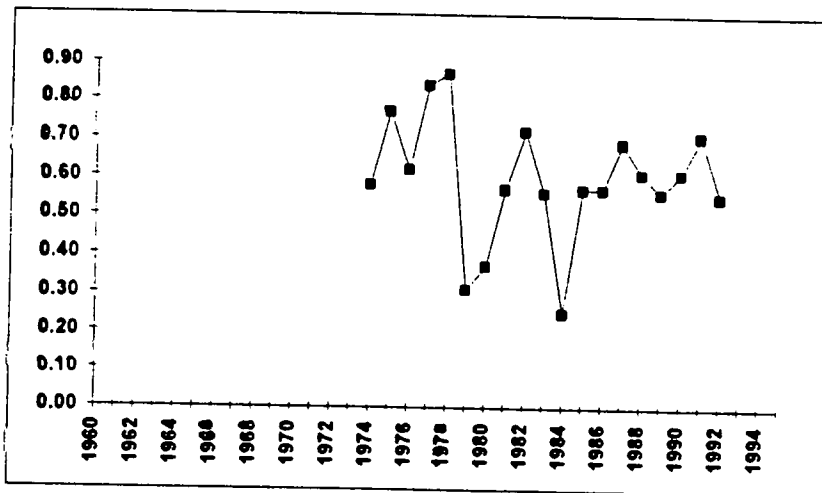
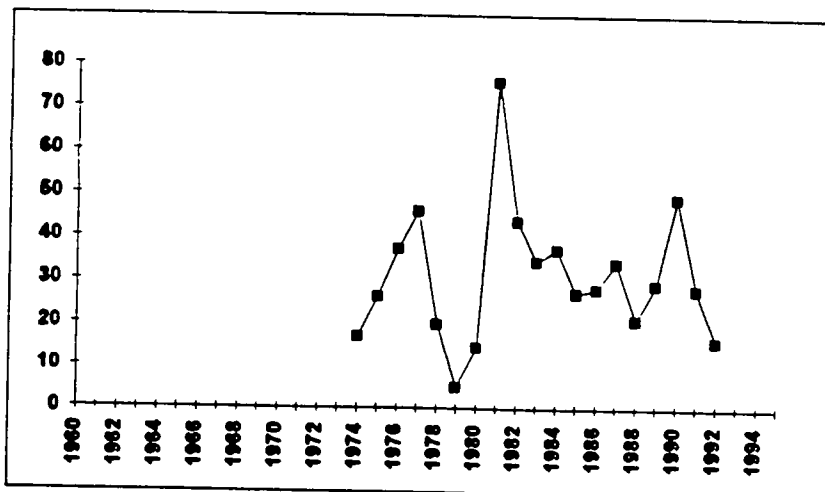

Fig. 1 .11e.

Recruitment (million)

Age 2



Pollock in 4VWX+5

ADAPT

Fig. 1 .11f.

Total Biomass (thousand t)

2+

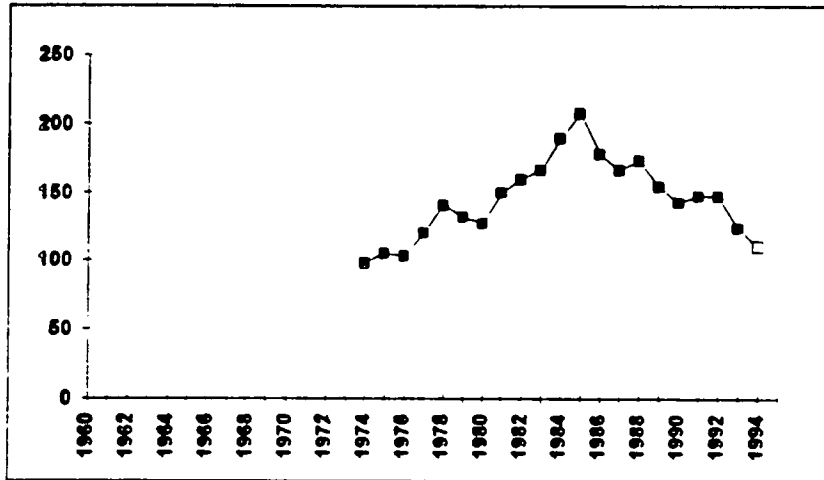

Fig. 1 .11g.

Spawning Biomass (thousand t)

4+

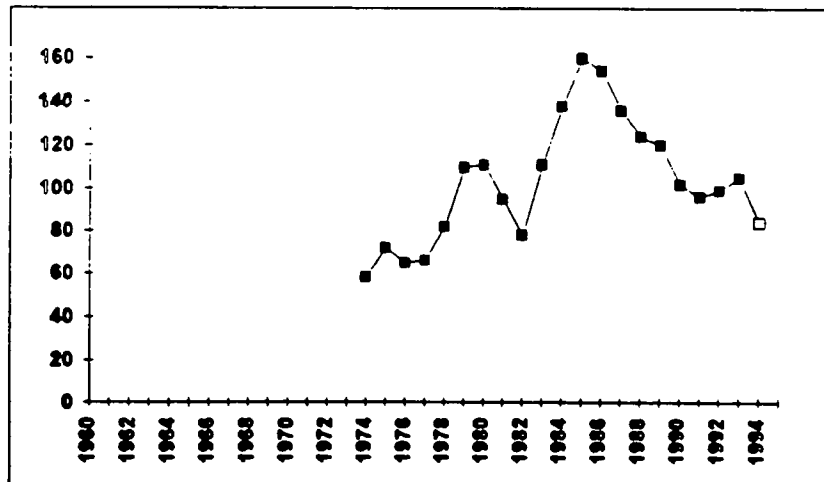
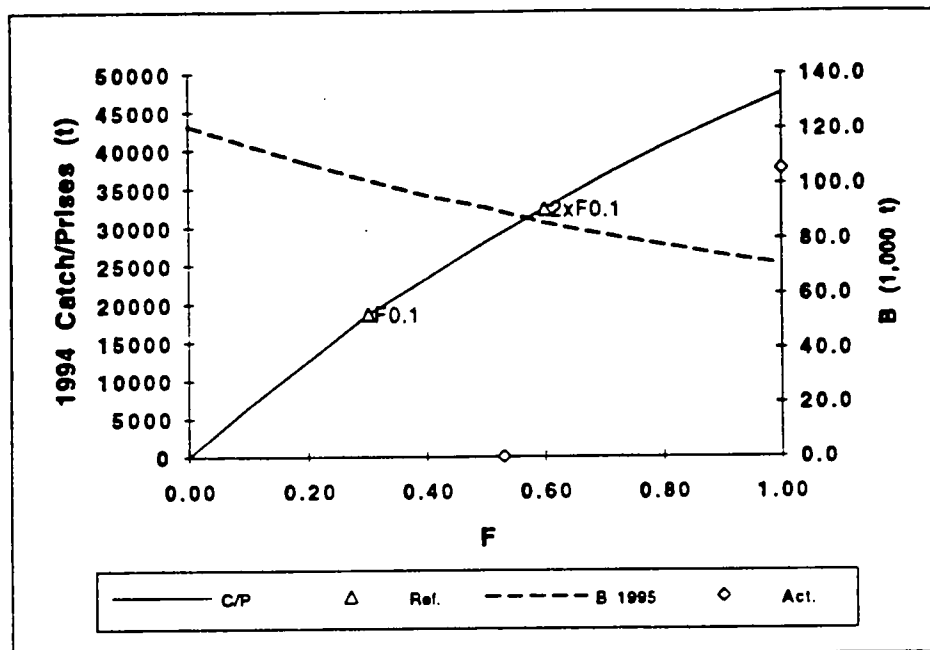



Fig. 1 .11h. Pollock in 4VWX+5Ze Projections



C/P = Catch - Prises  
 Ref. = Reference - Référence  
 B 1995 = Adult biomass at beginning of 1995 - Biomasse adulte au début de 1995  
 Act. = Actual - Actuel

F1992 = 0.53

Gulf Redfish

Fig. 1 .12a. Total catches (t) and TACs (t)

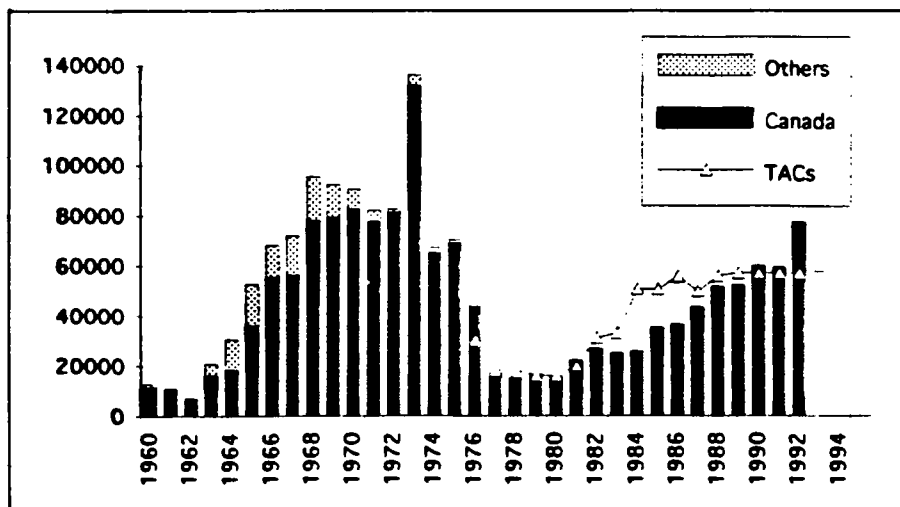

Note: TACs given for 1976-1992 are for the former management unit (4RST).

Fig. 1 .12b. CPUE (1/hr) OTB+OTM

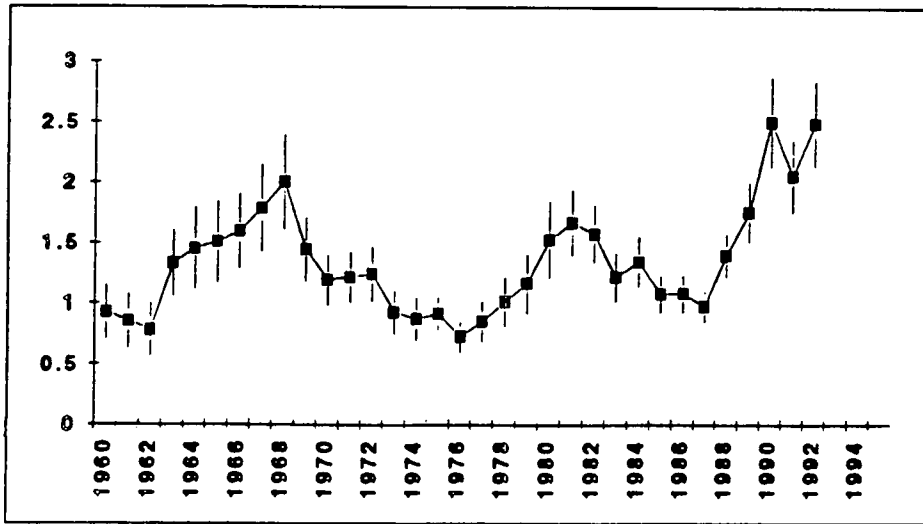

Fig. 1 .12c. CPUE (1/h) - OTB(May-Oct.)

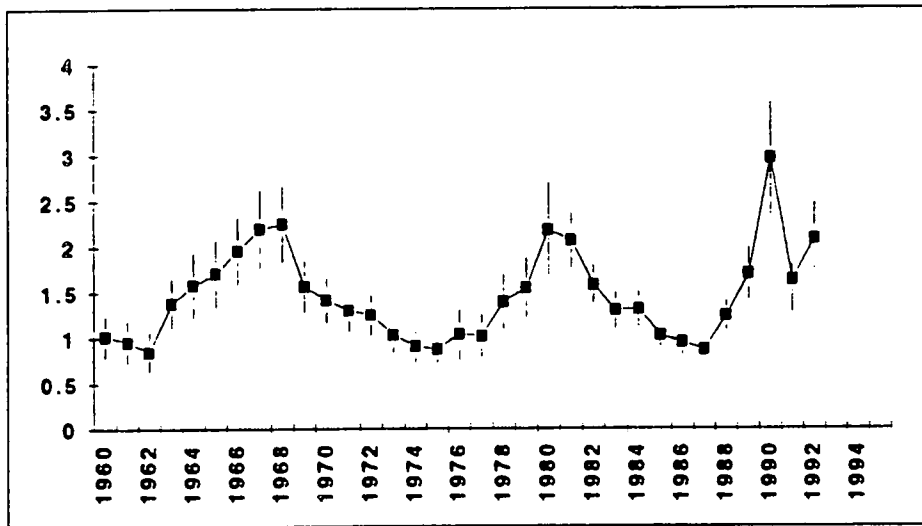
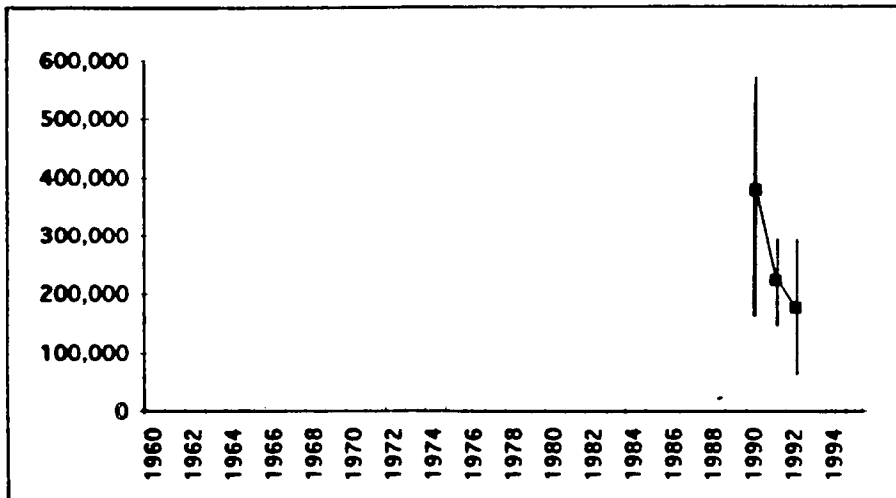

Fig. 1 .12d. Research vessel summer biomass (t).

All ages



Plaice in 2+3K

Fig. 1 .13a. Total catches (t) and TACs (t)

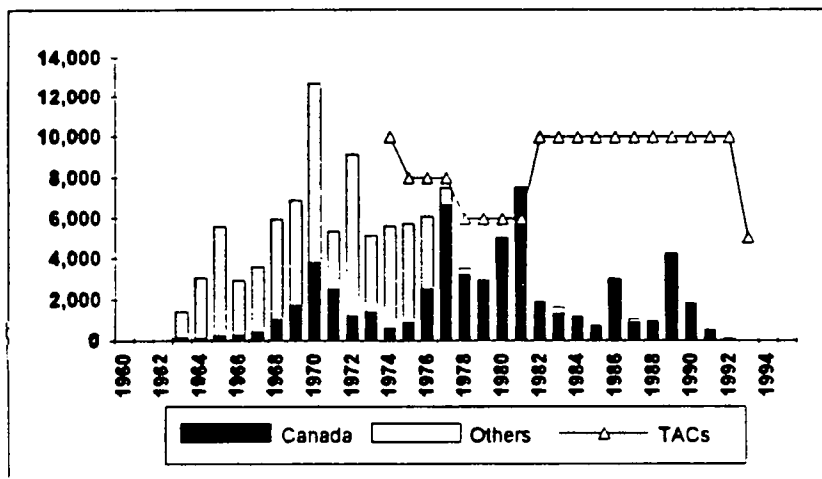
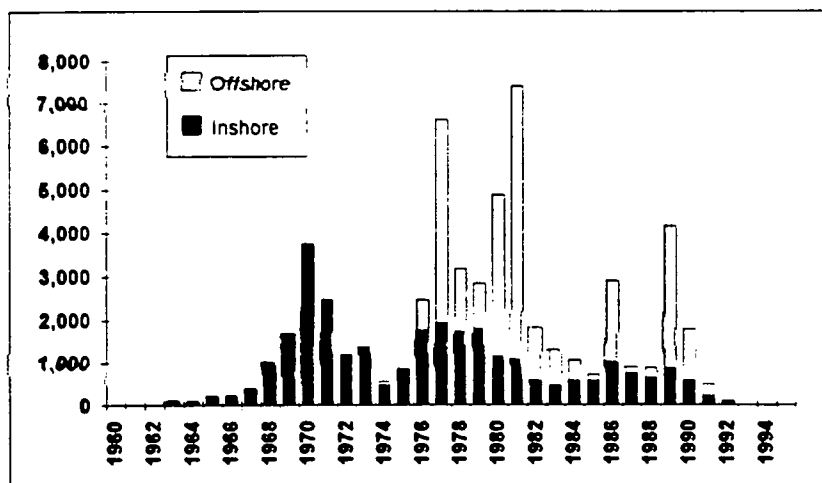

Fig. 1 .13b. Inshore and Offshore Canadian Catches (t)



Plaice in 2+3K

Abundance Indices

Fig. 1 .13c.

RV in 2J (#/tow)

1+

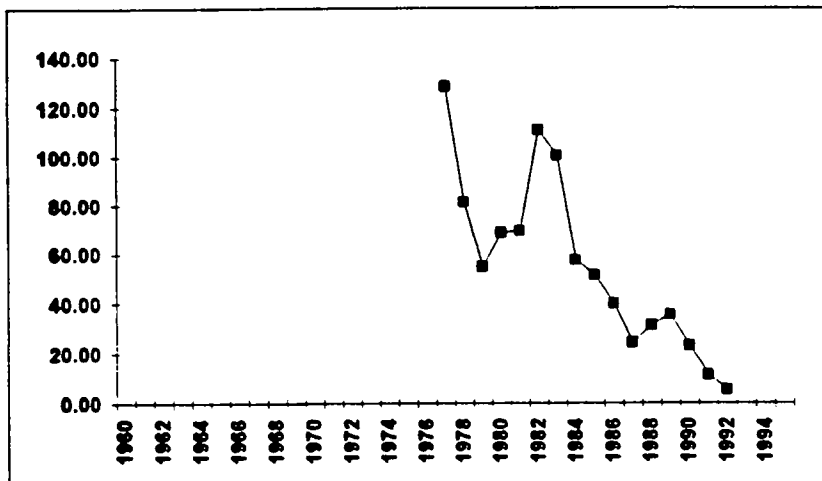
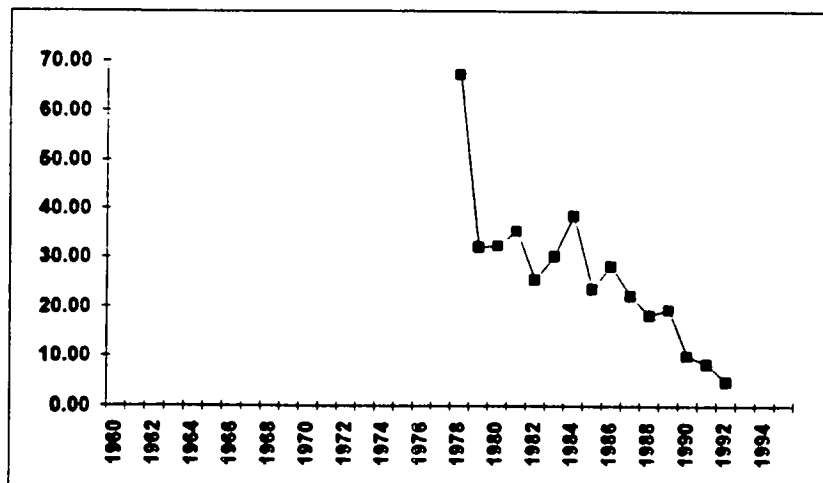

Fig. 1 .13d.

RV in 3K (#/tow)

1+



American Plaice in 3Ps

Fig. 1 .14a. Total catches (t) and TACs (t)

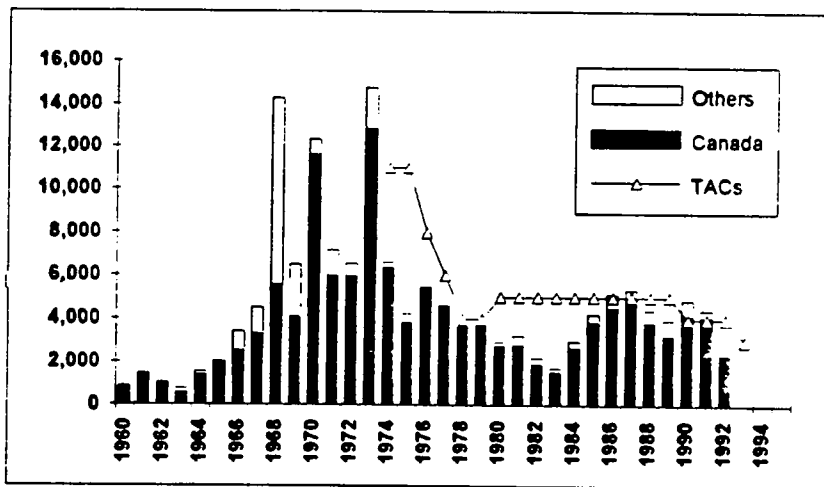
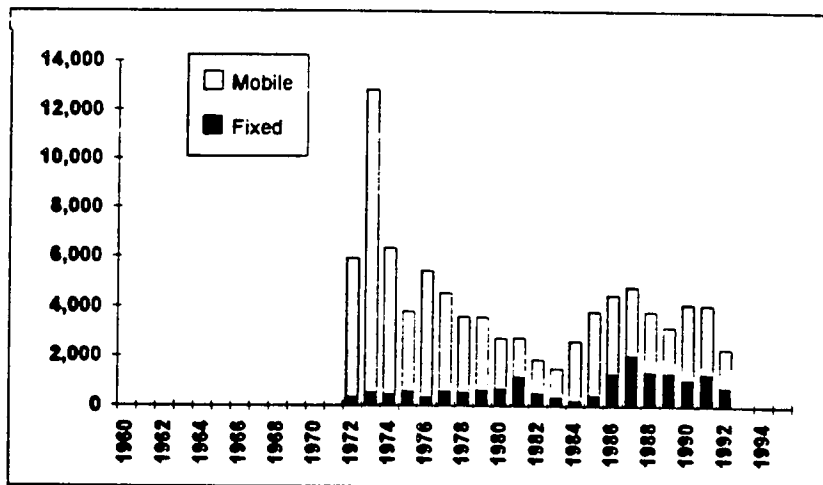

Fig. 1 .14b. Fixed and Mobile Canadian Catches (t)



American Plaice in 3Ps

Abundance Indices

Fig. 1 .14c.

Mean Weight (kg)

at age 10

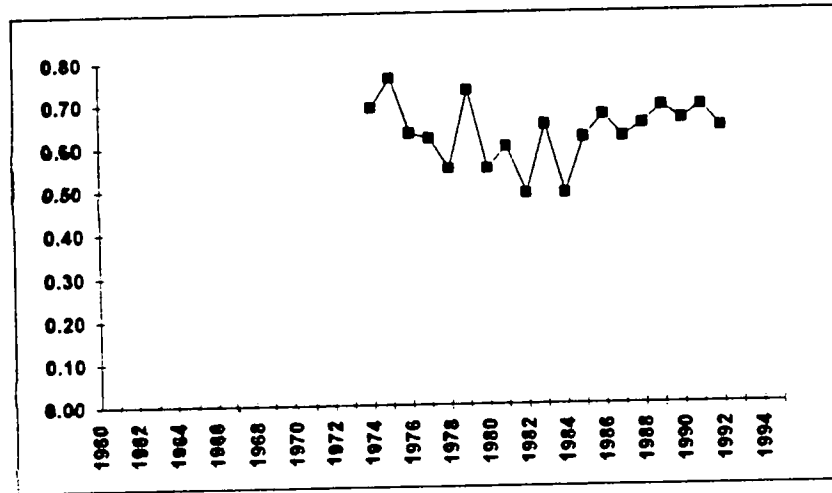
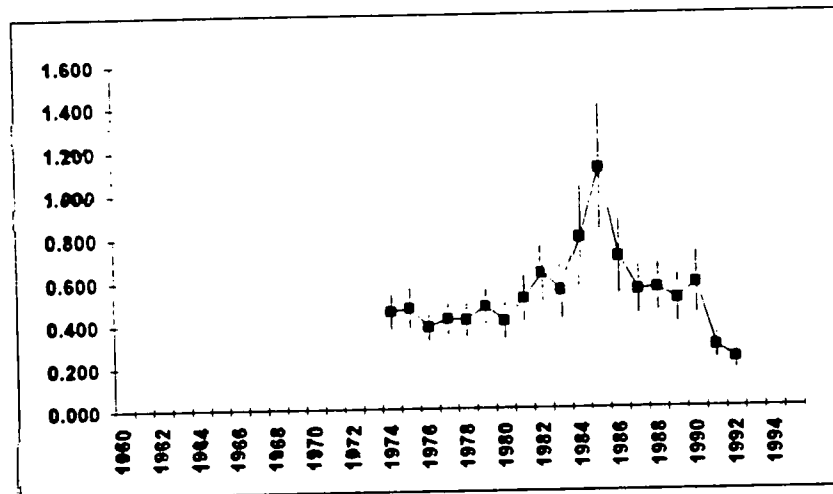

Fig. 1 .14d.

CPUE (units)

All ages



American Plaice in 3Ps

Abundance Indices

Fig. 1 .14e.

CAN RV (Mean # per tow)

1+

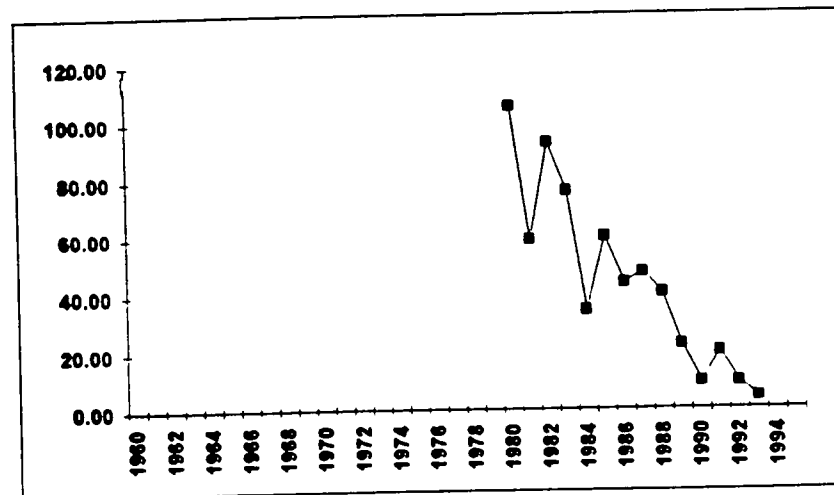
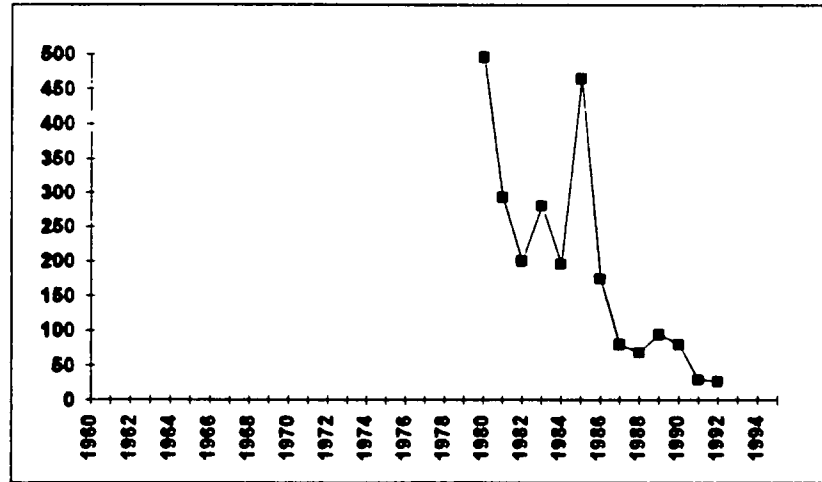

Fig. 1 .14f.

FRENCH RV (Mean # per tow)

1+



American Plaice in 4T

Fig. 1 .15a. Total catches (t) and TACs (t)

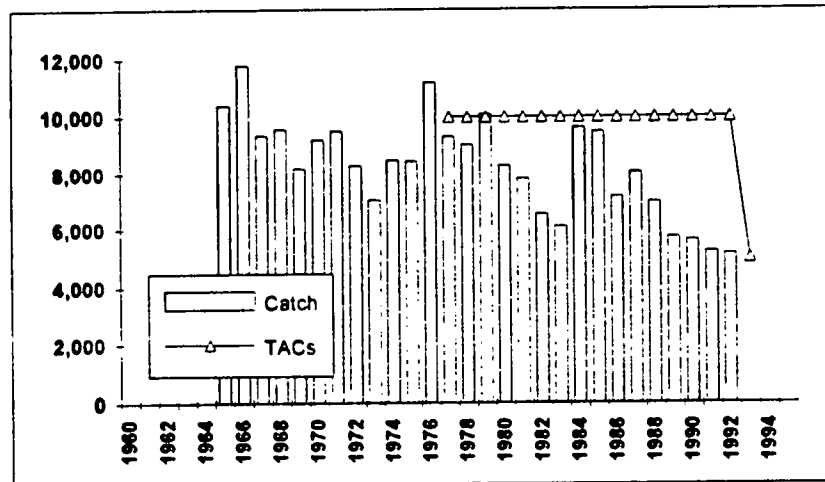

American Plaice in 4T

Abundance Indices

Fig. 1 .15b.

RV (#/tow) - Fall

1+

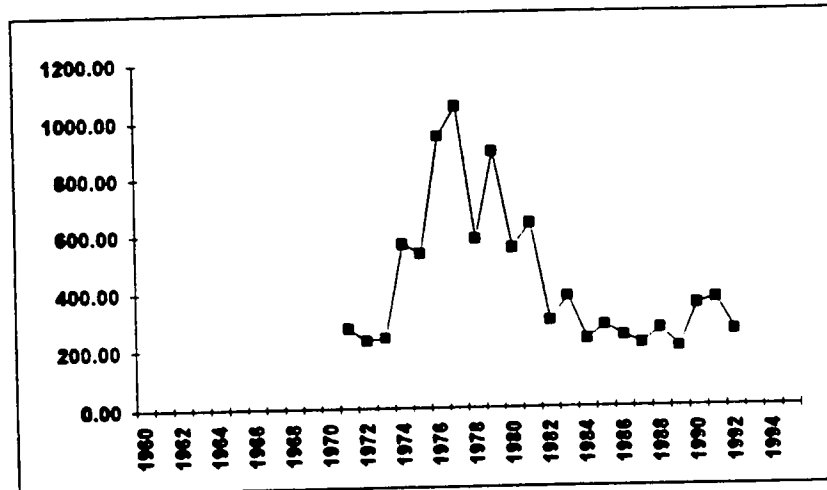

American Plaice In 4VW

Fig. 1 .16a. Total catches (t) In 4VW

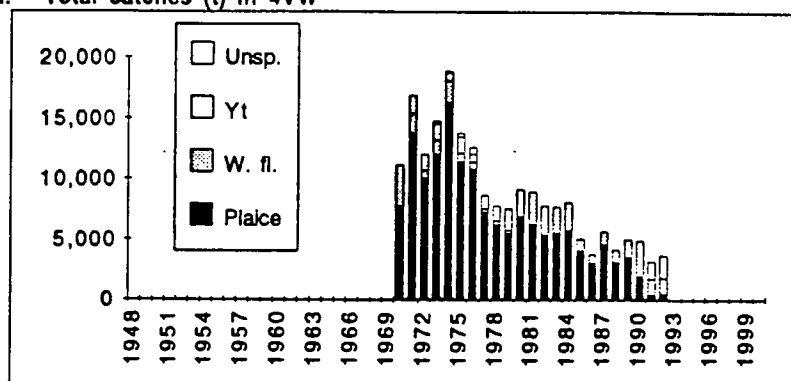

Fig. 1 .16b Summer RV Mean # per tow All ages

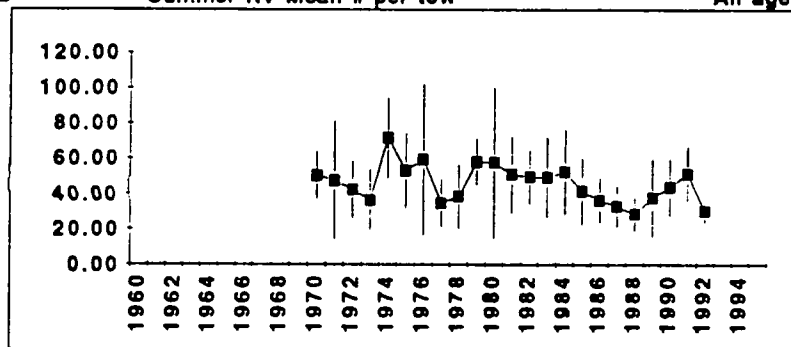
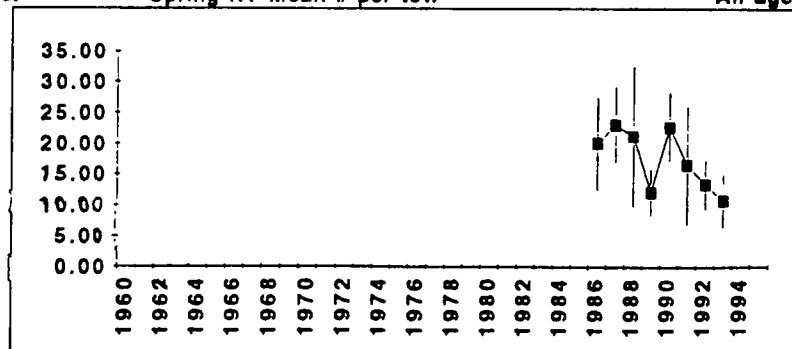

Fig. 1 .16c. Spring RV Mean # per tow All ages



American plaice in 4X

Fig. 1 .17a. Total catches (t)

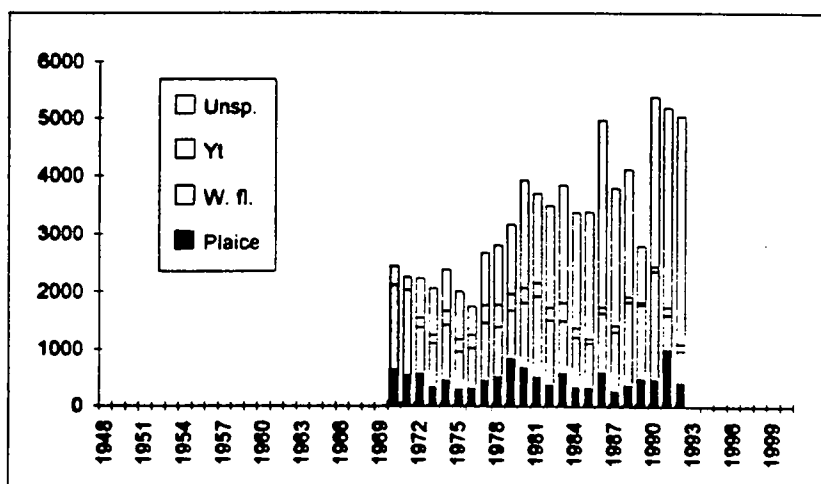
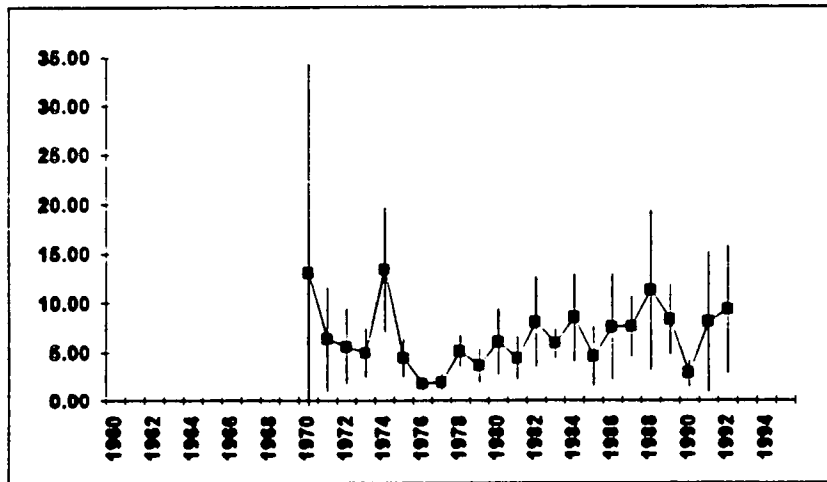

Fig. 1 .17b. Summer RV Mean # per tow All ages



Witch in 2J-3KL

Fig. 1 .18a. Total catches (t) and TACs (t).

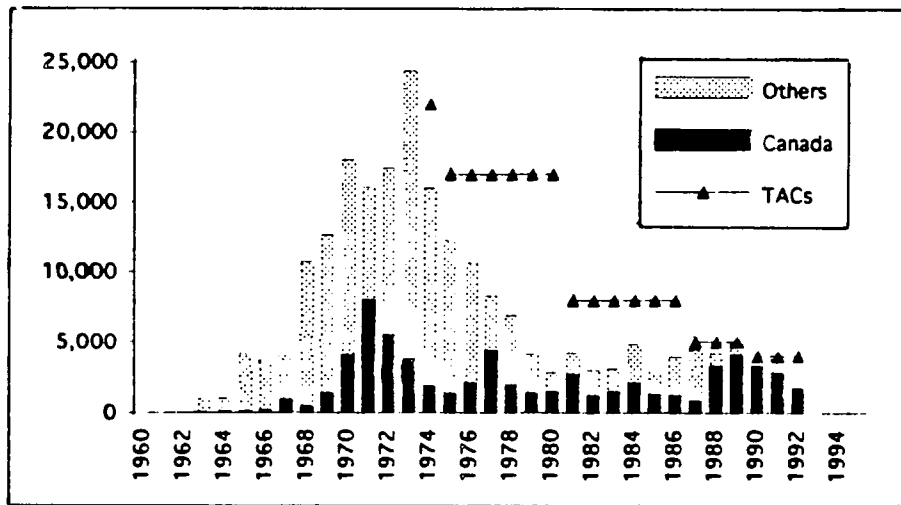
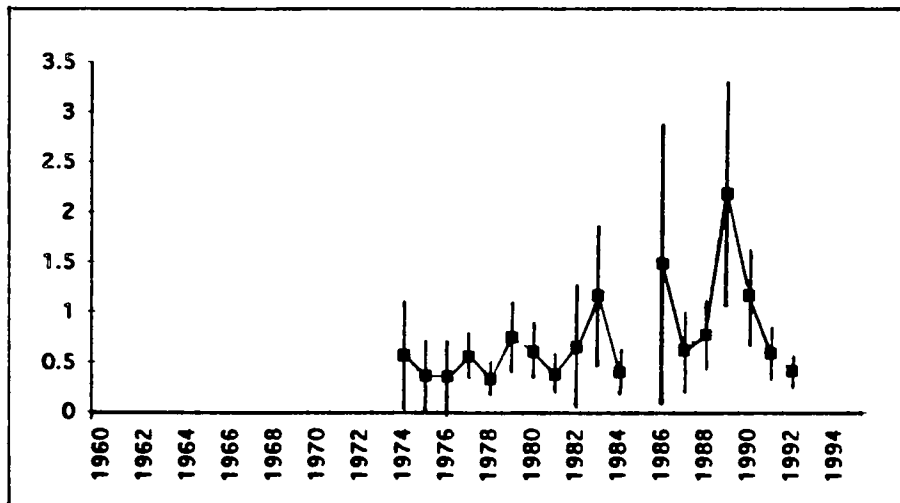

Fig. 1.18b. CPUE (t/hour) All ages





Witch in 2J-3KL

Abundance Indices

Fig. 1.18c.

RV Min. Biomass (t)

All ages

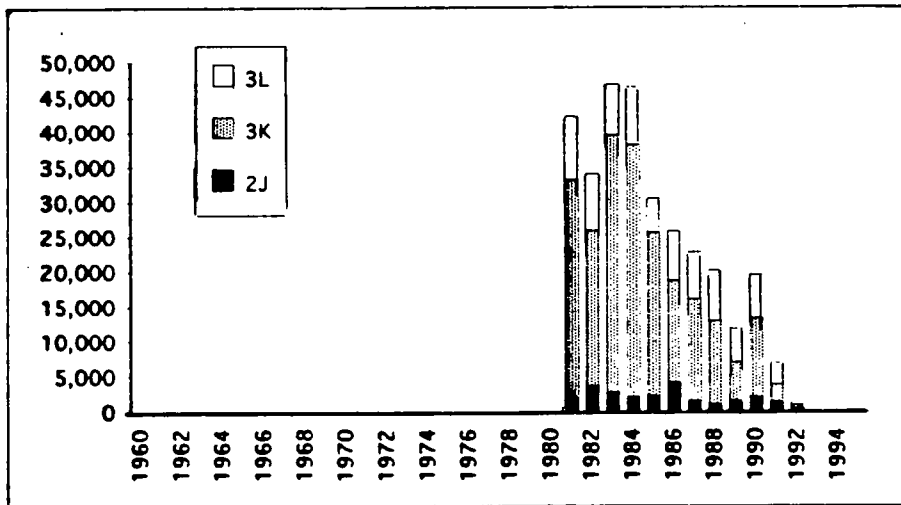

Witch in 3Ps

Fig. 1.19a. Total catches (t) and TACs (t).

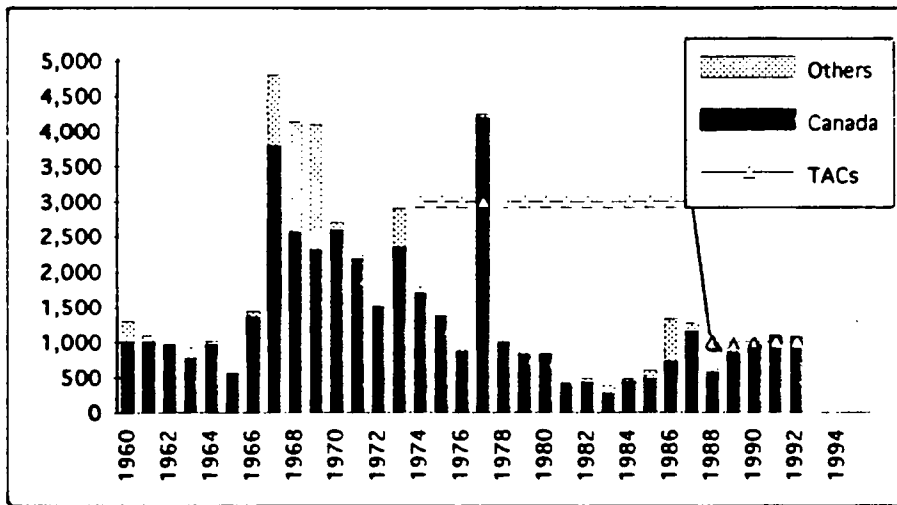
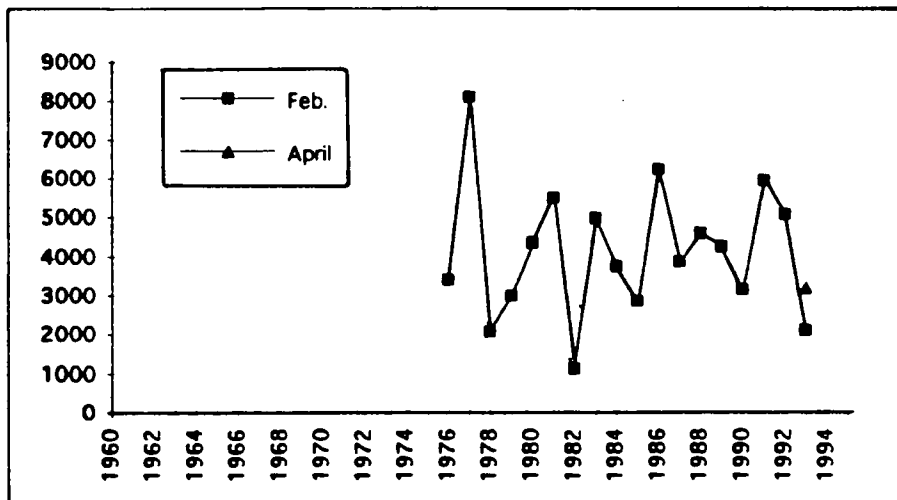

Fig. 1.19b. RV Min. Biomass (t).

All ages



Wtch in 4RS

Fig. 1 .20a. Total catches (t) and TACs (t)

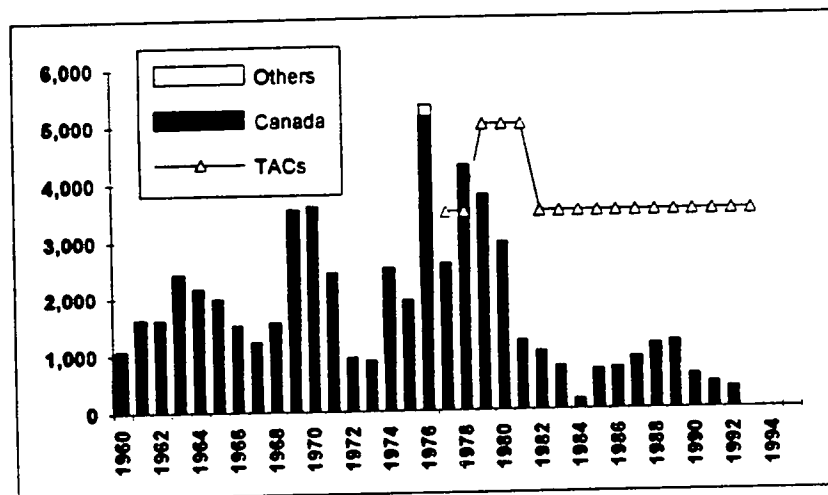

Wtch in 4RS

Abundance Indices

Fig. 1 .20b.

RV (#/tow) in 4R

All ages

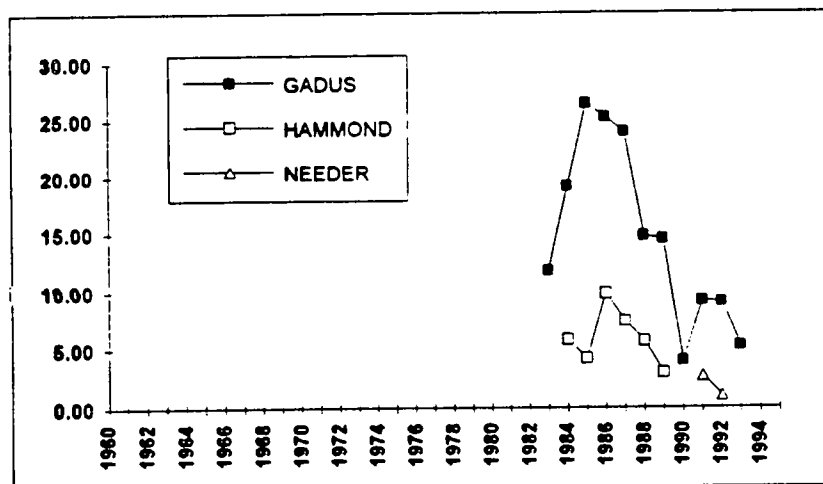

Fig. 1 .20c.

RV (#/tow) in 4S

All ages

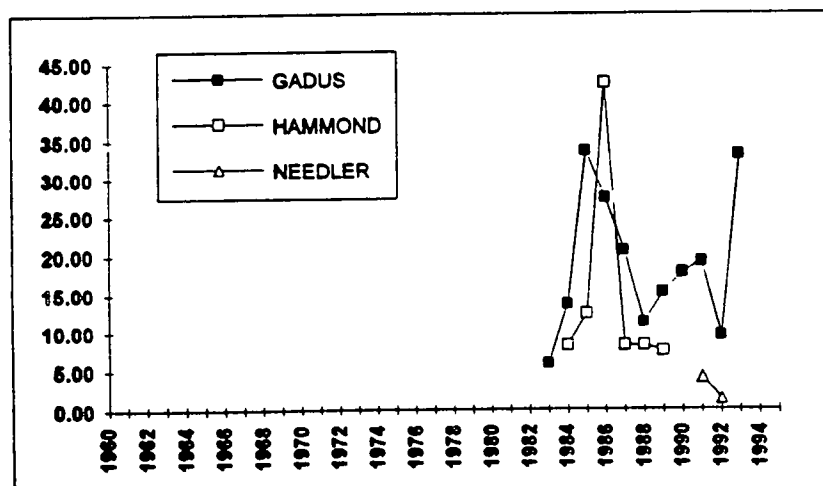

Fig. 1 .21a. Total catches (t) in 4VW.

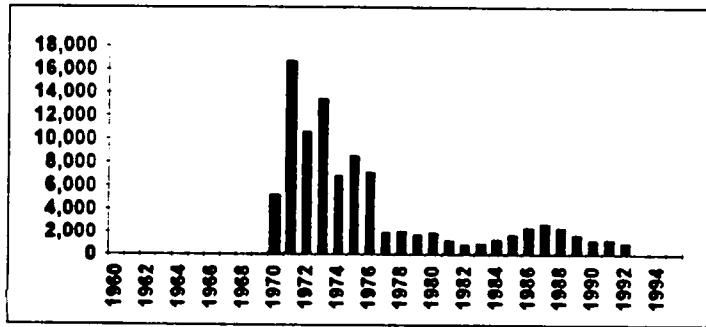

Fig. 1 .21b. Summer RV Mean # per tow All ages

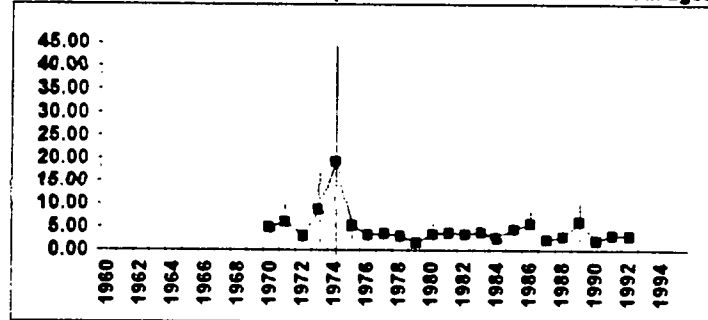

Fig. 1 .21c. Spring RV Mean # per tow All ages

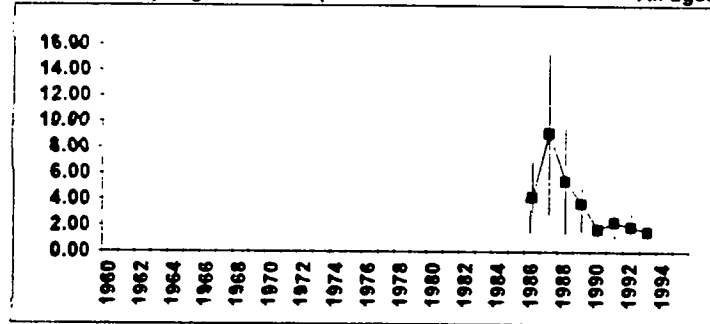
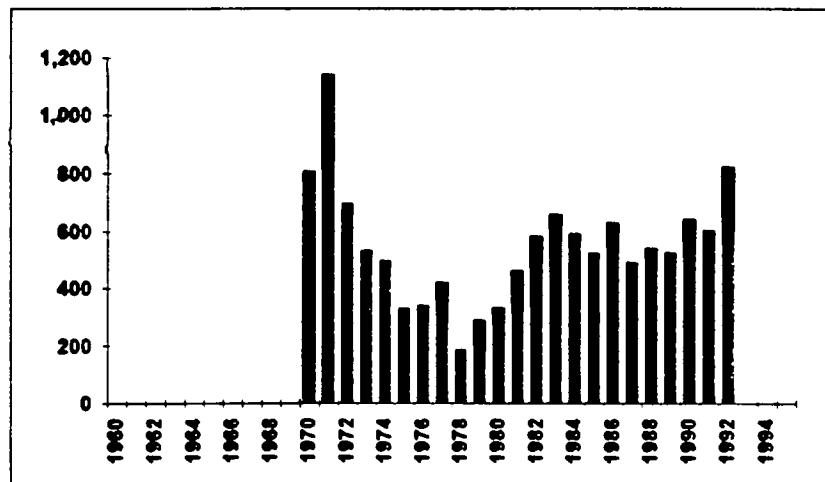

Fig. 1 .22a. Total catches (t)



Which in 4X

Fig. 1 .22b.

Summer RV Mean # per tow

All ages

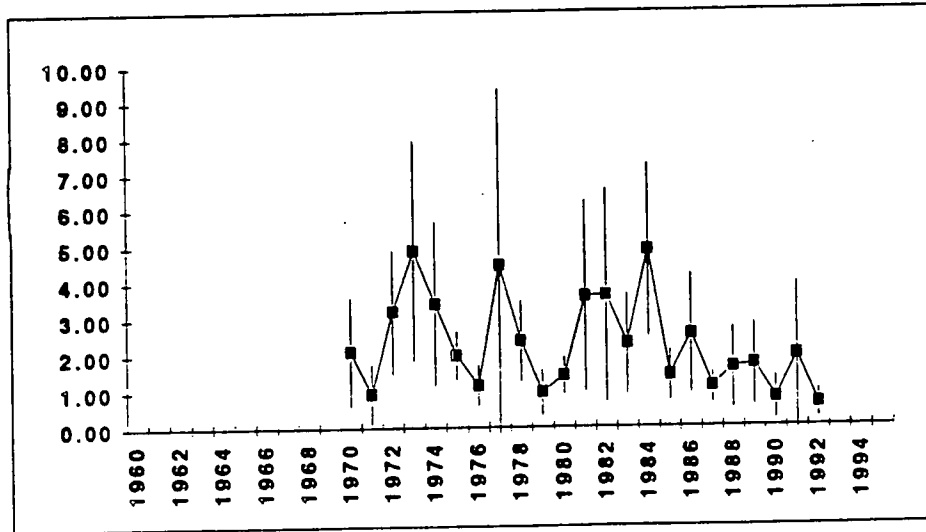

Yellowtail flounder in 4VW

Fig. 1 .23a.

Summer RV Mean # per tow

All ages

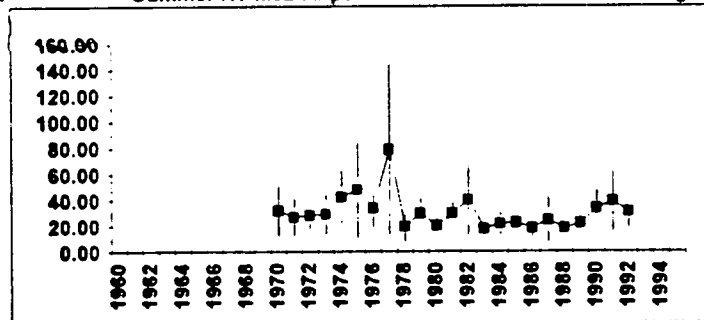

Fig. 1 .23b.

Spring RV Mean # per tow

All ages

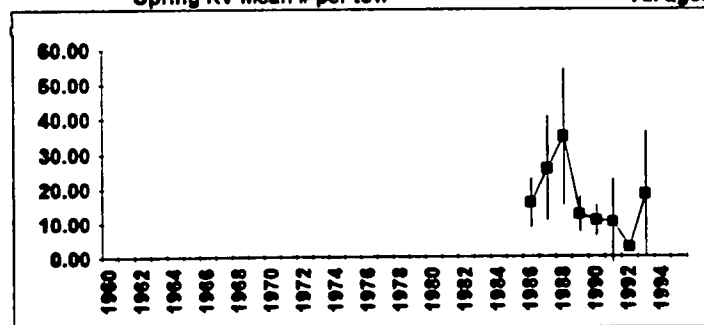

Fig. 1. 24a. Summer RV Mean # per tow All ages

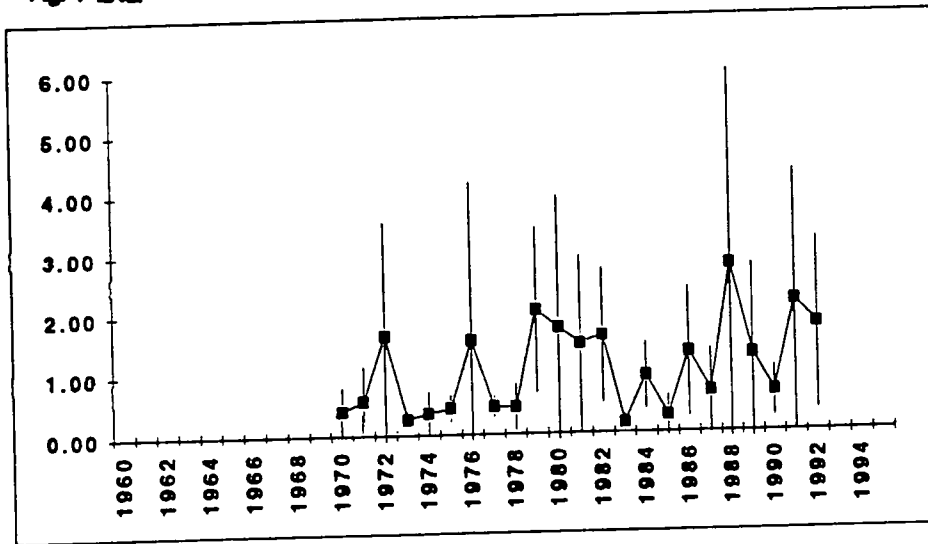

Fig. 1. 25a Atlantic Halibut in 3NOPS4VWX

Total catches (t) and TACs (t)

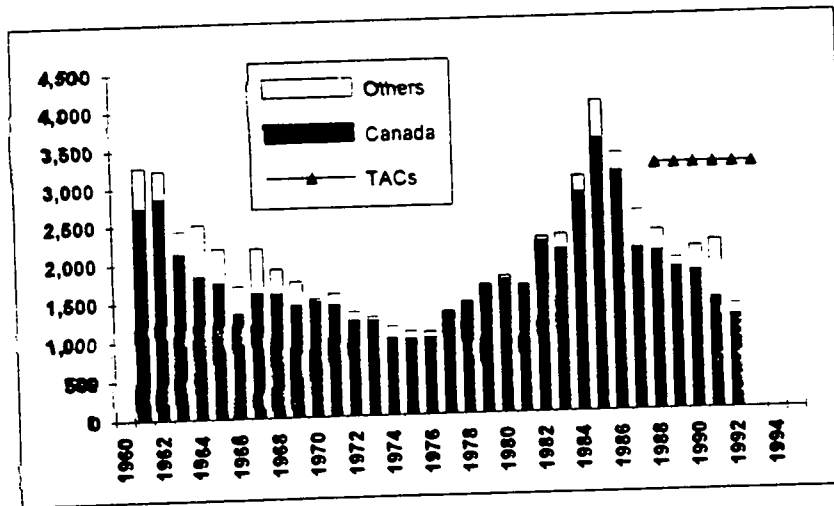
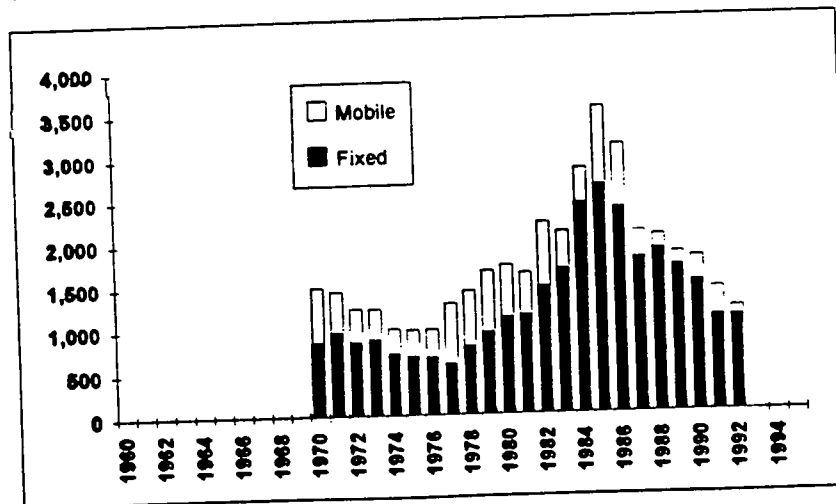

Fig. 1. 25b. Fixed and Mobile Canadian Catches (t)



Atlantic Halibut in 3NOPs4VWX

Fig. 1 .25c. RV - 4VWX summer (#/tow) All ages

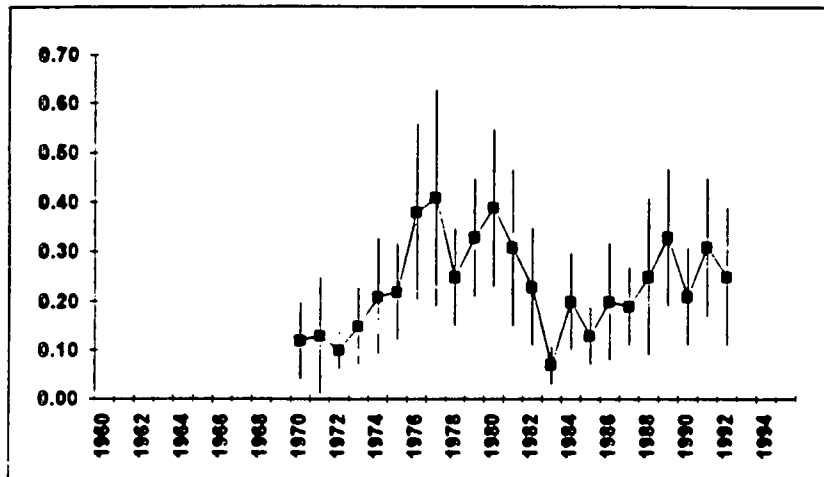

Fig. 1 .25d. LL CPUE (t/1000 hooks)

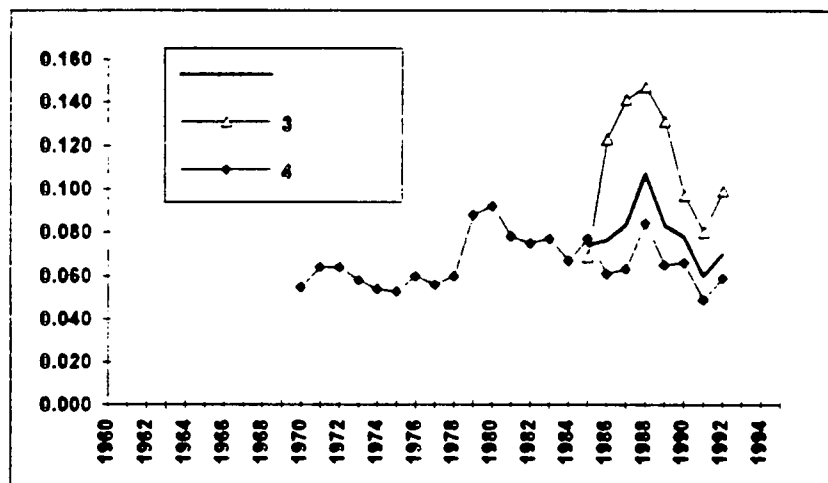
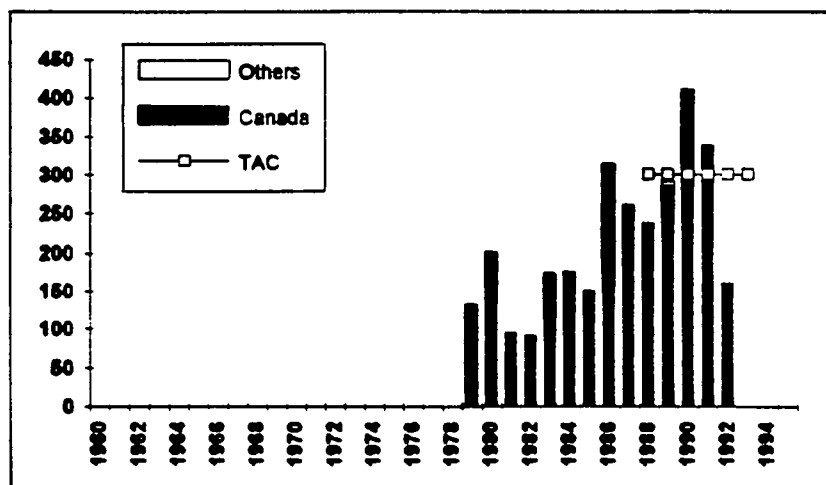

Fig. 1 .26a. Atlantic Halibut in 4RST

Total catches (t) and TACs (t)



Greenland Halibut in 4RST

Fig. 1.27a. Total catches (t) and TACs (t)

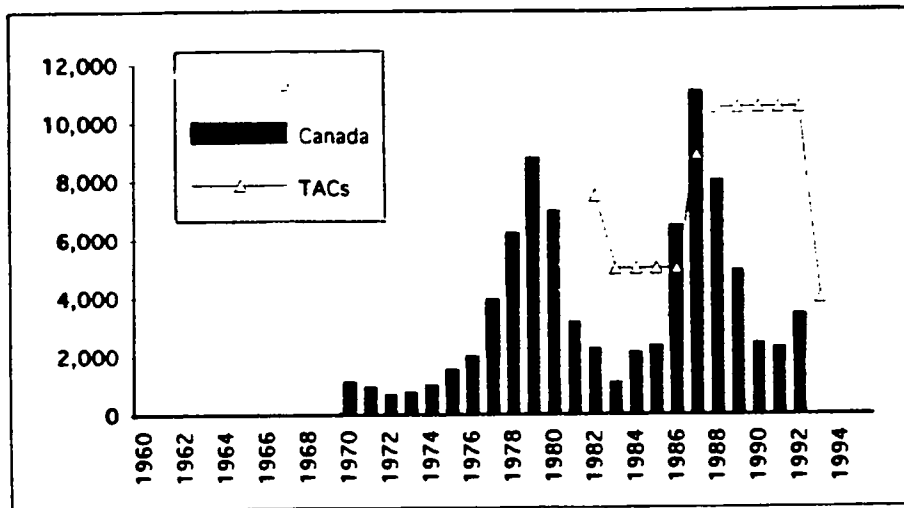

Greenland Halibut in 4RST

Abundance Indices

Fig. 1.27b. L. Hammond biomass estimate (t).

All ages

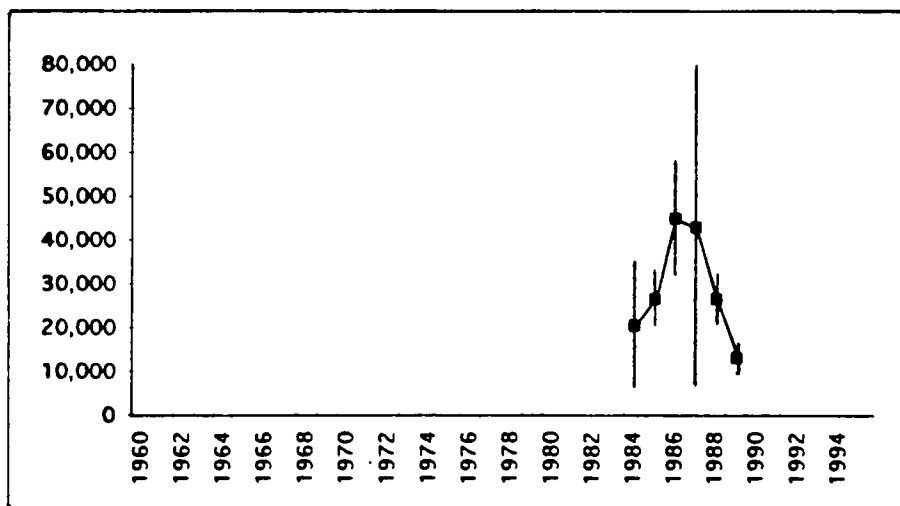
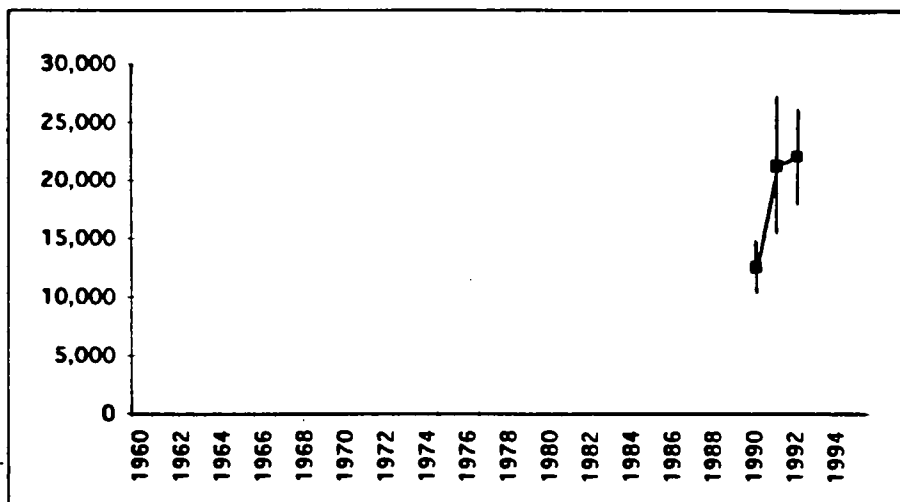

Fig. 1.27c. A. Needler biomass estimate (t).

All ages







#### 4. Descriptive narratives

##### 4.1. 2J3KL COD

#### SUMMARY

The northern cod stock continues to decline. The biomass is probably at its lowest level in this century and could be as low as 100,000 to 150,000t. This is lower than annual landings as recently as 1991.

If the stock is actually as low as recent surveys suggest, any catch may hinder its ability to rebuild. Because most recent year-classes have been weak and because northern cod do not spawn until about age 7, substantial recovery of the spawning biomass – the total weight of fish old enough to spawn – is unlikely before the year 2000 at the earliest.

Recently less than 40% of the fish present at the beginning of each year are still there at the end of the year. The fishery alone cannot account for this. A variety of other possible causes include harsh climatic conditions, low food supply, predation by seals or competition with seals for food, and migration out of the area.

The inshore "recreational fishery" should be closely monitored and if possible reduced. Any offshore fishing will diminish the spawning biomass. Recovery depends on these fish and on suitable survival conditions for eggs, larvae, juveniles and adults. During the winter of 1992-1993, most of the remaining stock has wintered on the Nose of the Bank, where foreign trawlers have been fishing.

#### ANALYSIS

Data from all available sources point to an ongoing decline. The annual groundfish trawl survey during the Autumn, 1992, estimated 70% less fish than the year before. There were fewer fish in all three NAFO Divisions (2J, 3K and 3L) than at any time since the surveys began.

Wide-ranging hydroacoustic (sounder) surveys since 1991 show a large and continuing decline in fish density, especially this year (February 1993). A tagging cruise in January, 1993, fishing the shelf edge from Hamilton Bank to the Nose of the Bank at depths of between 150 and 600 meters, found no concentrations of cod large enough to warrant tagging. In February, the only large concentrations the acoustic survey could find were on the Nose of the Bank outside the normal survey area, in waters 930 meters deep.

There is conflicting evidence on what has happened to this stock, and when the major decline took place. At first, examination of both DFO's trawl and sounder surveys and the offshore fishery suggested an abrupt decline in the first half of 1991. Closer examination suggested that the decline may have been more gradual beginning in NAFO Division 2J, off southern Labrador, in 1990.

A variety of indicators suggest that significant changes in the ocean have been underway since the late 1980s. For example, either the abundance of capelin has dramatically decreased or its distribution is completely changed since the autumn of 1990. Cod have been in poorer condition since 1989, especially in 2J. Northern cod have been moving south and moving deeper for several years. By autumn, 1992, more than 80% of the biomass was in NAFO Division 3L (compared to a historical average of about 30%). The sharp decline in the spawning biomass reflects a loss both in the absolute numbers of fish and in the average weight of individuals. Recently, for example, the average weights of fish aged 4-7 have been the lowest since the early 1970s. The smaller size and the lower number of mature adults has several implications. Small females produce fewer eggs, so that a spawning population of smaller fish may be less productive. Also, the spawning period may not last as long for younger fish. This could mean less chance that a high number of eggs and larvae survive.

Changes in the abundance, distribution and condition of cod and other species appear to be related to a cooling trend in the area through the 1980s. Too little is known about the basic ecology of the northwest Atlantic to be precise about causes and effects. Whatever the role ocean conditions have played in the collapse, it is clear they will determine the pace and perhaps even the possibility of recovery. Stock rebuilding will depend on the appearance of several strong year-classes and on their survival to maturity. Ocean conditions heavily influence the survival of cod eggs and larvae, and thereby the strength of each year-class recruited to the fishery as young fish grow up. The last abundant year-classes were born in 1986 and 1987. These were both preceded and followed by years of low survival, so that most of the biomass now consists of fish aged six and seven.

Recent studies tend to confirm the existence of inshore "sub-stocks" of northern cod which winter in some of the bays of the northeast coast. This raises the possibility that inshore spawning may be more important to the overall strength of the stock than was previously believed. Annual groundfish surveys do not go close to shore because of untrawlable bottom and therefore miss these fish, so their abundance is unknown. The severity of the effect of the recreational fishery on these inshore fish is also unknown.

The environment of northern cod continues to be colder than the long-term average. Near record low air temperatures persisted over the adjoining coastal area throughout 1992. Cold air and strong northwesterly winter winds led to earlier formation, wider extent and longer duration of sea ice than normal. Near-bottom water temperatures at Station 27 were slightly warmer than 1991, but continue the cool trend observed since 1983. Similarly, the extent of the Cold Intermediate Layer, a body of water with temperature less than 0° C, was lower than 1991 but larger than the long-term average. Bottom temperatures throughout the 2J3KL area, measured in the fall groundfish survey, were below the 10-year average in 1992.

## ASSESSMENT

The population model used by fisheries scientists worldwide, as applied to northern cod, assumes that about 18% of the fish die each year of natural causes. Scientists know that the actual rate of natural mortality will vary from time to time, but the stock assessments which use this assumption have been satisfactory until recently. However the recent decline of northern cod has been too extreme to be explained by fishing alone. Scientists believe it is no longer appropriate to assume a constant natural mortality of 18% for recent years, but they are unable to determine a more appropriate number, so they have not used the model to estimate the current size of the stock.

---

Results of the latest groundfish survey, which is normally just one ingredient of the assessment process, suggest that the biomass could be as low as 100,000 to 150,000t.

#### **BACKGROUND**

Landings from the northern cod stock since 1959 have ranged between a high of 810,000t in 1968 and a low of 44,000t in 1992.

In June, 1991, CAFSAC believed that the stock was still recovering from its low in the early 70's, and advised that a proposed TAC of 185,000t would allow for continued growth. However, the poor commercial fishery that year, followed by much lower than expected results in the 1991 groundfish survey, led to a reassessment in January, 1992. With all indicators pointing steeply down, scientists recommended that the catch in the first half of the year be cut in half from the year before, to about 25,000 tons.

In the formal assessment that followed, both CAFSAC and NAFO calculated that the total biomass and the spawning biomass were at or near the lowest levels ever observed. CAFSAC recommended that the catch be held as low as possible. The cod moratorium was put in place in July 1992.

Total catches in 1992, before and after the moratorium, were about 44,000t. The reported Canadian catch was 23,796 tons; France reported landings of 583 tons; Canadian surveillance estimates of foreign landings of cod on the Nose of the Bank were 14,300 tons; the "recreational fishery" took an estimated 5,000t, additional to that 5,000t included in the reported catch.

#### 4.2. 3Ps COD

##### SUMMARY

This stock has been in decline since the late 1980s. The rate of decline should slow as the relatively strong 1987 and 1989 year-classes continue to grow. Although the 1993 TAC of 20,000t represents a considerable reduction from catches in previous years, it may still produce an exploitation rate higher than  $F_{0.1}$ . Stock growth will require both reduced fishing effort and higher recruitment.

##### ANALYSIS

Problems in getting consistent information often hinders the estimation of the abundance for many stocks. Reliable estimates require a stream of comparable data collected under similar circumstances year after year.

The stock assessment therefore relies on bottom trawl research vessel surveys conducted by Canada since 1972 and by France since 1978. The French discontinued their survey after 1992. It is important to stress that estimates based on trawl surveys alone represent the "minimum trawlable biomass", not the total stock. In 3Ps, an unknown portion of the stock is out of the survey's reach; but this is assumed to be fairly constant from one year to the next, so that surveys should indicate trends in the stock.

The trend was increasing in the mid-1980s, and Canadian surveys suggested a minimum trawlable biomass of 85,000t in 1988. This was followed by a decline, then two slight increases, then a large decline in 1992. The estimate for that year was only about 16,000t. The validity of the 1992 survey results that led to this estimate was uncertain; evidence from the commercial fishery suggested that an unusual number of cod may have moved to deeper water outside the survey area. To determine the magnitude of this problem, the stock was surveyed twice in 1993; in February and again in April, when more of the fish should be up on the bank within normal depths.

However, the 1993 survey results showed a continued decline. The February survey generated a minimum trawlable biomass estimate of 12,000t. The April estimate was even worse: only 7,800 tons.

The Canadian catch is taken chiefly by fixed gear fisheries. An adequate time series of catch and effort data from this gear sector is not available. Although catch and effort information are available from the Canadian and the French otter trawl fisheries, their interpretation has been difficult. French catch rate data may have been influenced by learning over time: as trawler skippers become more familiar with an area, increased fishing success does not necessarily indicate increased fish abundance. The French catch rate may also have been influenced by large changes in catches from one year to the next and by restrictions on where the vessels could fish. The age composition of the Canadian catch rates changed considerably more from year to year than would have been expected. These problems prevent using the catch rate information in the assessment.

## ASSESSMENT

The stock assessment, however, uses commercial catch data, in particular the weight and number of fish of each age, to create a numerical model of the stock. In effect, the process tries to answer the question: how many fish at each age must have been out there, at the start of the season, to have yielded these results? This modelling process has to make some assumptions about the growth rate and about how many fish die of natural causes. The model normally improves over time, because each year's catch data adds new information and shows up errors in earlier calculations. Normally, too, the model agrees with the trends which show up in trawl surveys, so that estimates of the total biomass can be made with some confidence.

In the case of 3Ps cod, catch at age from the commercial fisheries and indices of abundance from the research surveys were used in the assessments. The results are not very precise, perhaps because of changes in fish distribution of the 3Ps, 3Pn4RS and 3NO stocks. However, they indicate general trends, with the population declining since the mid 1980s and being presently the lowest or near the lowest observed.

## BACKGROUND

Cod landings from 3Ps ranged between 84,000 and 27,000t in the 20 years prior to 1979. Prior to 1978, the French catch was very low and was mostly landed by inshore boats from St. Pierre and Miquelon. Between 1960 and 1976, trawlers from other countries, chiefly Spain, fished heavily in 3Ps. By 1966 they were taking nearly as much as Canada. Altogether, the various fleets were taking from 40% to 90% of the spawning-age fish each year. The stock could not replenish these losses, so that landings declined until the late 1970s.

Fishing pressure eased after 1976, when the foreign fishery for cod ended in the area. Both the biomass and the landings began to recover. However Canadian landings, taken mostly by the inshore sector, remained very close to the 30-year average, so that France reaped most of the benefit of the stock recovery. Before the boundary decision, France took about 35% of the total catch, compared to less than 10% prior to the withdrawal of the foreign fishery. Up until 1977, inshore boats took most of the French catch. Since then trawlers have taken most of France's share. Trawlers from metropolitan France were prominent in the 3Ps fishery in the 1980s, especially after they were barred from the Gulf. However the metropolitan French trawlers have not fished in 3Ps since 1989. Trawlers from St. Pierre and Miquelon now land nearly all the French catch.

In the Canadian fishery, longlines take the largest portion of the catch, followed by gillnets, traps and handlines.

### 4.3. COD IN 3Pn and 4RS

#### SUMMARY

This stock may be at its lowest level in 20 years. The only reasonably large year-classes in the population were born in 1986 and 1987. These years were preceded and followed by years of poor recruitment. The spawning biomass of about 29,000t in 1992 is the lowest since 1974. Significant rebuilding will depend on future growth and recruitment.

TACs have been set at levels designed to achieve an exploitation rate of  $F_{0.1}$ , which is equivalent to catching about 18-20% of the biomass each year. However, similar to several other cod stocks, actual fishing mortality has been roughly double that rate, for reasons which are not clear.

#### ANALYSIS

This stock has in the past produced average landings of about 80,000t a year. Actual landings have varied between a high of 106,000t in 1983 and a low of 29,000 last year. Most of the fish in last year's catch were five-year-olds from the 1987 year-class.

The number of older fish in last year's catch was the lowest since 1974. The average weight of fish at each age was also the lowest since 1974. Low numbers, poor growth and poor recruitment mean that rebuilding the stock to the point where it can once again yield landings of 80,000t will be slow.

In the 20 years prior to 1990, year-classes ranged between 43 and 196 million fish. However, the average in the latter half of that period has been markedly lower, except for an estimated 140 million in 1987. Year-classes since then are thought to have been weak.

Enforcement problems have complicated the management of this resource in the past. These may have been eased recently by increased observer coverage and more stringent efforts to reduce the catch of small fish.

In recent years this stock has been surveyed in winter and summer. The winter survey, by the chartered research trawler *Gadus Atlantica*, occurs at a time when fish are migrating. This may affect our understanding of the distribution of these fish, but should not affect the biomass estimates if all the fish remain within the area surveyed. However, some northern Gulf cod may migrate into 3Ps in winter. Further studies are looking into this.

Since 1991, a summer shrimp/redfish survey in 4RST has been expanded into the shallower waters used by cod at this season. Because the winter survey by the *Gadus* may be discontinued after 1994, the usefulness of the results of the summer surveys as indicator of cod abundance will be assessed. Two new measures of fish abundance could compensate for the loss of the winter survey. One is an index fisherman program begun in 1990, which monitors the fishing success of selected individual inshore fishermen as an indication of stock abundance. Another will monitor the catch rates of selected mobile gear vessels.

**ASSESSMENT**

The number of fish aged three and over in this stock reached a low of 200 million in 1988. It increased slightly by 1990 and has been largely unchanged since then. As mentioned earlier, the stock now consists chiefly of fish spawned in 1986 and 1987, with poor recruitment from older and younger year-classes. A rough estimate of the 1990 year-class is 100 million individuals, which would be about equal to the long-term average. It is important to note that this year-class was prominent in the 1991 summer survey, but not in the same survey the following year. It could therefore be less abundant than 100 million individuals as presently estimated.

The spawning biomass, estimated at 29,000t in 1992, is the lowest since 1974.

#### 4.4. COD IN 4T & 4Vn (January to April)

##### SUMMARY

This stock has been declining since the mid 1980s and it is currently at its lowest level since about 1950. Further analysis and revised catch data suggest that the abundance in 1991 was at least 30% lower than was estimated last year. Fishing mortality – the proportion of the stock which is caught each year – appears to have nearly doubled since 1989. Although fish growth has improved slightly over the last few years, weights-at-age are still lower than those of the 1970s. Recruitment – the survival of young fish to a catchable age – has declined since the early 1980s.

##### ANALYSIS

When growth rates and recruitment are average, this stock should be able to produce landings of about 50,000t a year. Catches between 1950 and 1992 have varied between 104,000 and 22,000t, with an average of 56,000 tons.

The catch in 1991 fell to 47,000, and declined further to about 39,000 last year of which about 4,400 were taken outside of the stock area, primarily in 4Vsb. This was about 4,000t below the TAC. Fixed gear fishermen account for this shortfall. Their landings (3,742 tons) were the lowest since at least 1965. The otter trawlers were able to catch most of their allocation, despite several closures when the weight of fish less than 41cm in the catch exceeded 15% of the total catch. Estimates of discards were in the range of 10-11%, as in 1991.

Most fishermen believe the stock is down considerably from the mid-1980s. Catch rates have declined, but not as steeply as they might have without improvements to fishing technology.

More than 30% of the fish caught in 1992 were five-year-olds. It appears that fish of this age were successfully targeted by the fishery in 1992. Fish from the large 1979 and 1980 year-classes, which had supported the fishery in the mid-80's, were not abundant in this year's landings. The average weight of mature fish at various ages was higher last year than in 1991, but still much lower than during the 1970s.

The research vessel Alfred Needler replaced the Lady Hammond for the abundance survey on this stock. Comparative fishing experiments held before the changeover allowed to adjust the Needler's catch rate data to make it comparable with the Lady Hammond data from earlier years. Survey estimates, based on numbers of fish per tow, have been declining since about 1986. Four and five-year-old fish were the most abundant in the 1992 survey despite being at the lowest levels observed for these ages since 1977. The survey found a distinct tendency for fish aged three and four to occupy shallower waters than the fish aged five and older. This pattern has been seen before in periods of low abundance.

##### ASSESSMENT

To calculate the abundance of this stock, the assessment depends chiefly on two sources of data: the catch rates in commercial otter trawls and the numbers of fish per tow in the research surveys. The data from



each of these sources is analyzed using a variety of population modelling techniques, and biomass is estimated based on which of these seems most consistent with the others, and with trends in the commercial fishery.

All analyses indicated that the stock had been declining since the mid-1980s and was currently about the lowest since 1950.

Recruitment in recent years has been well below average. The 1987 year-class is now estimated at about 63 million fish, well below the long-term average of 87 million fish of this age. Changes in the ocean climate may have influenced the survival of young fish in recent years. Population biomass and abundance have been declining since the mid 1980s, and the spawning stock biomass is at about the lowest level in 20 years.

Since recent year-classes have been weak, biomass is not likely to recover significantly until recruitment improves.

#### 4.5. COD IN 4VsW

##### SUMMARY

The spawning stock and the fishable biomass are at the lowest levels since 1970. More than 60% of the fish are dying each year from fishing and natural mortality. Nearly all the fish remaining are at or under the legal size. As the stock has declined, fish have concentrated in a smaller area, which could have made them more vulnerable to fishing.

The requirement that fishing be stopped when more than 15% of fish landed are below the legal size has severely curtailed the fishery in 1993. If the 1993 TAC of 11,000t is taken, the spawning stock biomass will continue to decline. At such low biomass and given the recent poor survivorship of juveniles, any recovery will be slow.

##### ANALYSIS

Catches from this stock ranged between 40,000 and 80,000t from 1958 to 1974, then fell to a low of 10,000t in 1977. Catches climbed quickly back to 50,000t after Canada took over jurisdiction. However, quotas and landings have fallen since then. The catch was down to 29,800 in 1992. As of the end of May, the 1993 catch was only 500t, compared to about 15,000t by this date in previous years.

Before 1980, Division 4W and Subdivision 4Vs each contributed about half the catch from this stock. Over the next eight years, the proportion caught in 4Vs climbed to 87%. The balance has begun shifting back since then. Roughly 70% of the catch is taken by otter trawls, 25% by longline and the remainder by seines and gillnets. Some fishermen complained of the difficulty of finding legal-sized fish in 1992. There were reports of many tons being discarded in order that a few might be landed.

Fishing effort has become more concentrated in recent years with an apparent contraction in the distribution of the stock. As well, there has been seasonal shift due to the disappearance of the the spring fishery on spawning aggregations in 4W. Trawler catch rates may not be a reliable index of fish abundance when fish are more concentrated, so population estimates do not use this data.

##### ASSESSMENT

Research surveys of this stock are conducted in March and July. They show increasing abundance in the late 1970s, some fluctuations in abundance in the early 1980s and a decline since then. The survey in March, 1992, showed the lowest number on record. This may be extreme, given that the next two surveys, in July and the following March, were somewhat higher.

The surveys indicate that the year-classes born in 1986 and 1987, especially the latter, are the largest in recent years, however they are still lower than the long term average. The 1987 year-class has made up more than 45% of the number of fish in the surveys conducted since these fish grew big enough to catch.

The most recent calculation of stock size indicates that the spawning biomass is extremely low, comparable to levels in the mid 1970s when the stock was severely depleted. In recent years, recruitment – the number of fish surviving to a catchable size – has declined well below the long-term average. The 1987 year-class, for example, while the largest for some time, is a little more than two-thirds of the long-term average.

The 1992 summer survey has shown a high percentage of small fish indicating a low fishable biomass. The March, 1993, survey found few cod above the legal size. Catch data from the commercial fishery confirm this. These signs all suggest a resource depleted to the point where even the lower catches of recent years are taking more out of the stock than natural growth can put back.

### POSSIBLE CAUSES

There are several possible causes of this rapid decline.

The first is that the stock may have reached a state where the efficiency of fishing increases substantially. For example, if a smaller stock gathers more densely in a smaller area, the same level of fishing effort would remove a higher proportion of the fish. The remainder would occupy an even smaller area, and be that much more vulnerable to fishing. Similarly, as the average size of fish declined, it would take more fish to make the same tonnage and this again would mean a higher percentage rate of mortality. Interactions between various factors, such as temperature, prey or predator distribution, could magnify these effects.

Recruitment has been low from 1985 to at least 1989, even though the spawning biomass in that period was fairly high. The apparent disappearance of spring spawning may be a cause of this low recruitment, or it could be a symptom of some other cause. In any case, low recruitment at a time of high spawning biomass suggests a very poor survival rate for cod in their first three years of life. Now that the spawning biomass is extremely low, continued poor survival of the young would make it hard for the stock to recover.

There is much evidence that oceanographic conditions have changed on the eastern Scotian Shelf since 1985. Water temperatures near the bottom have been unusually cold, especially in 4V. Capelin, a cold water species, has been more abundant in the area since the mid-1980s. Nonetheless, more analysis is required before the link between fish production and ocean climate can be verified.

Based on the number of grey seal pups born on Sable Island in 1990, the age 1+ population was about 61,900 in that year. Numerous studies of the grey seal diet, based chiefly on the contents of stomachs, show the seals eat herring, cod, mackerel, sand lance and silver hake. Most fish eaten are from 15-35 cm long, which in the case of cod would mean fish 1-3 years old. There are still many uncertainties about what foods grey seals prefer, how much they need and where they are at different seasons. This makes it difficult to calculate confidently their impact on 4VsW cod at this time. A full evaluation is planned for later this year. Survey data on the abundance of cod at different ages show that more fish are dying as they approach the legal size. This suggests that overfishing and discarding may have more effect than seals, because seals are eating fish substantially smaller than the legal size.

#### 4.6. COD IN 4X

##### SUMMARY

Biomass estimates based on survey results indicate this stock is down by about 10% from 1992 and has been declining rapidly since 1990. The stock is now at or near the historic low. The decline has not been as critical as in other cod stocks farther north, but a lower rate of exploitation would allow rebuilding, producing higher catch rates and higher yields in future years.

Catches have fluctuated irregularly over the years, with a general downward trend. The fishery is taking young cod as they reach legal size. This has two negative effects. First, taking fish when they are small provides a lower yield than capturing some of the same fish a few years later. Second, a fishery dependent on young fish is vulnerable to fluctuations in "recruitment" – the survival of fish to a catchable size. This is inherently unstable.

##### ANALYSIS

Landings from this stock have averaged about 20,000t since 1960, with peaks in 1968, 1982 and 1991. The catch in 1992 was 26,000t and equal to the TAC, which was set at that level for 1991-93. This is higher than reported catches in the late 1980s, but the earlier numbers may be less reliable.

Fish hatched in 1987 and in 1989 were prominent in both the otter trawl and longline catches in 1992. Fish from the 1985 year-class, which had been important in previous years, were greatly reduced by last year. Trawl surveys in recent years also found the 1985 and 1987 year-classes to be stronger than most. The surveys indicate a stock decline of about 10% by weight and 25% by numbers between 1991 and 1992. However, these results are not 100% certain because the survey cannot cover nearshore areas due to rough bottoms and the fraction of the population being close to shore may vary from year to year.

The survey has not been a reliable indicator of the abundance of young fish, which tend to be more common near shore.

Catch rate data from 139 commercial vessels show an increase from 1987 to 1989 and a decline thereafter with a marked increase in fishing effort between 1990 and 1992. Commercial catch rate data have not been used in the population model to calculate stock abundance, because of suspected misreporting and under-reporting in past years.

##### ASSESSMENT

The assessment of cod in 4X has involved the use of two statistical models of the population. With these, using the trends from the trawl surveys, and the catch data from the fishery, the abundance of fish at each age and the proportion taken by the fishery was estimated. Over time, as new catch and survey information is added to the model each year, this technique can build a fairly clear picture of the abundance of each year-class. However, the models provide a clearer view of the past than of the present or future.

With some stocks, this modelling approach suffers from a strong "retrospective pattern". For reasons which are not clear, estimates of the abundance of some year-classes have to be lowered as new data becomes available. Despite these limitations, the modelling techniques used in cod stock assessment are considered the best available. In the case of cod in 4X, the retrospective pattern seems to apply only to the younger year-classes and is not as severe as in other stocks. These, however, now make up most of the stock.

The results of the two models used were essentially the same. They indicate that the 1985 and 1987 year-classes were among the strongest since 1970. Apart from these two years, recruitment has been lower than average during the 1980s. The biomass has declined rapidly from a peak in 1990. It is worth noting that the peak in the early 1980s, sustained by stronger recruitment, lasted longer than the peak in 1990. The latter depended almost entirely on the 1985 and 1987 year-classes, and dropped as these were fished down.

The assessment has assumed average recruitment between 1990 and 1993. However, if these incoming year-classes continue the trend of lower recruitment, the future of this stock could be worse than the model indicates.

If the 1993 TAC of 26,000t is fully taken, the total biomass will decline from an estimated 68,000t in January 1993 to 47,000t the following year. If the TAC of 26,000t in 1993 is taken,  $F_{0.1}$  catches in 1994 would be about 7,000t. A 1993 catch of 18,000t would be roughly similar to the fishing pressure on the stock in recent years, and would leave a biomass of about 55,000t next year.

The biomass has fluctuated between 50,000 and 80,000t since 1970 and is currently at about its lowest level. Lower quotas would distribute the available yield over more years, give higher catch rates, and maintain a larger spawning biomass over the long term.

#### 4.7. COD ON GEORGE'S BANK (5Z] and 5Zm)

##### SUMMARY

Only an immediate and substantial cut in the harvest of this stock can slow the decline it has experienced in recent years. Because the fish are caught on both sides of the boundary between Canada and the U.S., this will require consistent management between the two countries.

The fishery is now highly dependent on young fish, and therefore subject to fluctuations in abundance. Sustained catches on the level of 1991 and 1992 would remove more fish than natural growth can replenish. Because these are fast-growing fish, spawning as young as age three, a few years of good recruitment and lower catches could build the stock back quickly.

##### ANALYSIS

Cod landings from this area between 1978 and 1992 peaked at 26,000t in 1982, averaged about 15,000t between 1983 and 1987, then increased to 20,000t in 1988. Landings have fallen since then, to about 17,000t in 1992. Canada takes about 65% of the total. Historically, the Canadian fishery in this area has been dominated by otter trawlers but in recent years longlines and gillnets have taken nearly half the Canadian share.

Because these cod grow quickly, fish as young as two years old are above the legal minimum and are taken in the fishery. In 1992, 42% of the fish in the commercial catch were two-year-olds, hatched in 1990. This was the highest catch of fish this young since 1987, when the strong 1985 year-class was entering the fishery. This year, small Canadian draggers were allowed to begin fishing in January. Roughly half their catch was from the 1990 year-class. However, a substantial portion of the catch was larger, spawning fish. Study of catch and effort of the Canadian trawler fleet show catch rates in decline and effort increasing, except for 1992, when the introduction of individual boat quotas may have altered the picture.

Both Canada and the U.S. carry out trawl surveys of this stock, Canada in the spring and the U.S. in spring and fall. Average catch per tow in the Canadian surveys declined sharply in 1991 and 1992. U.S. survey catches in the same period have been the lowest on record. The trawl surveys confirm a strong, persistent pattern of migration back and forth across the international boundary. Fish younger than age four seem to migrate more than the older cod in this stock. Generally speaking, the fish move into the Canadian zone for the spring and summer, and out of the zone in the autumn and winter. However, the number found in either zone can vary considerably from one year to the next. For example, the proportion found in the Canadian zone in spring and summer has ranged between 20 and 100%. This wide variability complicates the calculations of biomass and estimates of the impact of various levels of fishing effort by the Canadian fleet.

##### ASSESSMENT

The abundance estimates for this stock have an unusually wide margin of error. However, while the biomass estimate for any one year is quite imprecise, the trend is clear; the stock has suffered a large decline. The total biomass and the spawning stock biomass are at the lowest level in years. Fishing mortality – the

proportion of the stock taken each year in the fishery – has been rising almost continuously since at least 1986.

The research surveys indicate that the 1991 and 1992 year-classes were well below average, so that fish hatched in 1990 will account for a large share of the landings in 1993. About half of these fish will still be immature.

The low biomass, high mortality and poor recruitment are cause for serious concern. The fishery, especially the mobile gear sector, is very dependent on young fish. Catching them so young means a low yield from the resource and a considerable sacrifice of the spawning biomass.

Because so much of this resource migrates into U.S. waters, restrictions to the Canadian catch alone will not reverse the decline. Canada and the U.S. may have to apply consistent management to rebuild this stock on a sustained basis.

#### 4.8. HADDOCK IN 4TVW

##### SUMMARY

This stock has been heavily exploited, the spawning biomass is low and year-classes since 1988 have been weak. Rebuilding the spawning biomass depends on the 1988 year-class, which now makes up the bulk of the stock. Continued fishing at the current level will greatly diminish the contribution these fish can make to stock recovery.

##### THE FISHERY

Landings averaged 26,500t a year from 1950 to 1969, fell to an average of 5,000t during the 1970s, and have ranged between 6,000 and 20,000t since then. The catch in 1992 was about 6,000t.

By 1987, after several years of low recruitment, the fishery was dependent on only two year-classes of haddock. This, and a low spawning biomass, led to measures to restrict the fishery to a 5% bycatch. The following year this was raised to 15%, a limit that remained in force through 1990. In 1992, the management approach changed to a combination of by-catch restrictions and trip limits.

Fishing in the haddock nursery area in 4W, mainly Emerald and Western Banks, was closed to mobile gear in 1987. However, fixed gear vessels have been allowed a directed haddock fishery in that area until this year. Until 1984, trawlers fishing in Division 4W took most of the catch from this stock. That year 4W was closed to trawlers from May to December, to protect the large year-classes of the early 1980s. The trawler fishery shifted to 4Vs, which was soon producing about half the haddock landings from this stock. Since 1990, however, landings from 4Vs have fallen to 780t. Meanwhile, the fixed gear fishery in 4W enjoyed a five-fold increase in landings after 1987. By 1991, trawler landings were down to only about 35% of total landings, while longlines took 63%. The longline catch in 1992 was the highest ever, at 3,494t. The trawler catch tripled that year, to 1,324t, with most of it coming from 4W in areas adjacent to the closed zone. The average size of fish was small, dominated by the 1988 year-class.

Inshore landings of haddock in 4W have declined steadily for 15-25 years, and more steeply in recent years. Inshore fishers also report changes in the migration of "inshore haddock". They describe these fish as different from offshore haddock in their colour, shape, taste and size.

##### DATA

Over the past year, questions have come up about the accuracy of methods currently used for aging haddock. The effect of the error would be to underestimate the age of older fish. The severity of this problem, if it exists at all, is still under study.

Regulation of the haddock fishery by trip limits and by-catch restrictions makes it difficult to use commercial catch rates as a measure of fish abundance. In the scientific surveys, however, catches increased in the late 1970s and early 1980s. In the summer surveys, catch rates have risen after 1987, due to the large 1988 year-class. Most of the survey catch comes from 4W. There has been very little haddock in 4Vn since the large year-classes of the early 1980s. Catches in 4T and 4Vs have been negligible. Exceptionally cold water



may explain the absence of haddock in Division 4V; these fish avoid waters below 4 C. Average bottom temperatures in 4V have been below 2.5 C over the past four years. Bottom temperatures in 4W have declined as well, but not as severely; the average in July has remained above 5 C.

A comparison of the last spring and summer surveys in 4W shows very little difference in the size of fish in the 1988 year-class between July and the following March. This could mean either poor growth or a high mortality among the fish which had grown to a catchable size. Recent surveys also show the presence of haddock in the 18.5 cm range. It is not clear whether these were fast-growing one-year-olds or slow-growing two-year-olds.

### ASSESSMENT

Analysis of commercial catch and survey data shows that the fishery has been taking a high proportion of larger fish (46.5 to 60.5 cm). This probably reflects both low numbers of large fish and the displacement of the trawler fleet from the closed area. Estimates of fishing mortality on the smaller fish show three distinct periods. The peak was from 1970 to 1976, before the 200-mile limit, when foreign vessels fished with small mesh gear on the Scotian Shelf. The exclusion of these vessels after 1977 reduced the fishing pressure on small fish. Banning trawlers from the nursery area in 4W also decreased fishing mortality on the smaller sizes, but may have led to greater exploitation of larger fish in other areas.

Spring and summer surveys both indicate that the haddock stock is now concentrated in 4W and consists mainly of fish spawned in 1988. The surveys have detected no large year-classes after this one. The 1992 summer survey caught no fish younger than one, and many fewer one-year-olds than usual.

The female spawning biomass of haddock has been in decline since 1981 and dropped to an estimated 4,000-8,000t in 1992. This is roughly as low as it was in the late 1970s, after years of trawling with small mesh gear.

### PROGNOSIS

It is not certain whether this stock can rebuild to the levels which produced average landings of 20,000t from 1950 to 1969. It is certain, however, that current levels of fishing pressure make such growth improbable on a sustained basis. The 1988 year-class is still fairly strong, but having most of the biomass contained in one year-class makes a fragile resource.

In any case, the 1988 year-class cannot remain strong if current levels of fishing continue. Reduced catches will accelerate the rebuilding of the spawning biomass and increase the possibility of strong recruitment. Without strong recruitment, this stock will remain low.

#### 4.9. HADDOCK IN 4X

##### SUMMARY

This is currently a fishery, in which mature fish are scarce and landings depend on the number of young fish which grow to a catchable size each year. Such a fishery is inefficient and vulnerable. However, moderate quotas and the relative strength of two recent year-classes should maintain the spawning stock biomass for the next several years.

Apart from the 1987 and 1988 year-classes, which were only average, recruitment has been below average for some time. Future growth will depend on a reversal of this trend.

##### THE FISHERY

Reported landings from this stock averaged about 20,000t between 1930 and 1988. They peaked above 30,000t in the mid to late 1960s, and during the 1980s. From 1982-84 and again in 1987-88, catches were below the TAC. They fell to 6,700t in 1989, when the scientific recommendation was that catches be kept as low as possible. That year, the mobile gear fishery was closed in mid-season.

In 1993, a directed fishery is permitted, with a TAC of 6,000t. This is about 30% more than the TAC in 1989 and 1990, but substantially less than actual haddock landings in 1990 to 1992.

The minimum mesh size for otter trawls was increased in 1991, which, combined with lower recruitment, reduced the capture of small fish. In the same year, individual transferable quotas (ITQ's) were introduced into the small dragger fleet (under 65 ft). ITQ's had a considerable impact on fishing strategies. Some vessels concentrated on flatfish, silver hake and shrimp, or fished in neighbouring 5ZJ,m, some negotiated transfers of quotas between vessels, and some avoided areas where haddock were abundant. Overall, the catch of the ITQ fleet declined by 28% in 1992.

The fixed gear fleet fished on trip limits of 6,800 kg of 4X haddock until March 1, 1992, when the limit was reduced to 1,500 kg. This gear sector caught 6,468t in 1992, an increase, compared to 2,776t for the small draggers which decreased. Larger trawlers and the gillnet sector caught 419t and 251t respectively.

People in the industry say that misreporting of catches was common between 1985 and 1988, was low in 1989 and has increased slightly since. It may be that some of the reported increase in longline haddock landings results from transshipping catches from small draggers.

##### DATA

Recently discovered problems in aging haddock are not resolved. As a result, estimates of the abundance of different year-classes are based on the varying lengths of fish in surveys and in samples of the commercial catch. Haddock age 1 and 2 can be easily distinguished by length.

Judging year-class strength by the lengths of fish in the surveys from 1988 to 1992, indicates that the 1987 and 1988 year-classes are average, 1989 is very weak, and 1990 and 1991 are below average.

The size of fish in the commercial catch has been fairly consistent from 1978 to 1992, averaging between 49 and 53 cm. The proportion of small fish (under 44 cm) rose to 20% in 1983-86 and again in 1990. The increase in 1990 probably reflects the recruitment of the 1987 and 1988 year-classes, which were only average but were nevertheless much higher than the two years before.

Otter trawl catch rates have not been a reliable index of haddock abundance, because of high and variable levels of misreporting. In recent years, however, the longline vessels fished haddock with few restrictions, and therefore little incentive to falsify catch data. Analysis of their January and February haddock catch rates show a 25% increase from 1989 to 1992. The catch rates of research vessels were low during the 1970s and high in the early to mid-1980s. Catch rates declined to near-record lows from 1985-1987, then rose near the average to 1991, then dropped 50% in 1992.

#### ASSESSMENT

Judging from the catch of research surveys, recruitment has been average or below average since 1983. The surveys have provided relative estimates of population size since 1970. They indicate that the female spawning stock biomass was below average during the early 1970s, peaked at about 30,000t in the late 1970s and early 1980s, fell back to average levels by the mid 80's and declined further to 9,000t in 1987-1989.

Since then, the appearance of two average year-classes in 1987 and 1988 have helped to rebuild the spawning biomass to about 15,000. This is still below the long-term average of about 19,000t since 1970. How much influence the spawning biomass has on the level of recruitment has never been clearly shown; but common sense and some statistical work suggests that with a large spawning biomass 4X haddock is more likely to thrive.

#### PROGNOSIS

The 1987 and 1988 year-classes will probably continue to make up the bulk of landings for the next several years. The current TAC of 6,000t implies that as these fish grow, the proportion of the stock being taken in the fishery, that is the fishing mortality, will probably decline. This lower quota will help to maintain the spawning biomass and extend the period over which these two year-classes contribute to landings. Without strong recruitment, however, catch rates will decline as these fish are taken.

#### 4.10. HADDOCK IN 5Zj AND 5Zm

##### SUMMARY

Adult biomass estimates indicate that the stock is down by almost 50% from 1992, continuing a decline from 1990. The stock is now at or near the historic low. This stock straddles the maritime boundary between Canada and the U.S. Because most of the fish are on the Canadian side and migration is limited, conservation measures by Canada alone would benefit the Canadian fishery. But the stock is severely depleted, so the possibility of achieving recovery would be greatly enhanced if consistent restrictive measures were adopted by both countries. Restrictions on the Canadian side alone would not rebuild the stock but may prevent further depletion.

##### THE FISHERY

This stock has supported a commercial fishery since the early 1920s. Landings reached an all time high of 60,000t in the mid-1960s, and have ranged between 2,500t and 25,000t since then. In recent years, landings have fluctuated around 5,000t.

In 1992, recognizing the depleted state of the stock, CAFSAC recommended that the Canadian catch be limited to 2,500t. The Canadian industry, unconvinced of the value of Canada acting alone, lobbied successfully against quota cuts. The Canadian TAC remained at 5,000t, but Canada could only catch 4,000t because mobile gear vessels were unable to catch their allocation. Landings by the American fleet increased to 1,700t. The fishery was opened to trawlers on pre-spawning and spawning aggregations in January and February, 1993 for the first time in recent years.

##### DATA

The commercial fishery in 1992 was almost entirely supported by the 1985 and 1987 year-classes, which comprised over 70% of the landings.

The catch rates on research surveys indicate a decline in adult haddock over the last three years to amongst the lowest levels ever. The 1975 and 1978 year-classes were strong, while those of 1983, 1985 and 1987 were average. Recruitment since then has been low. The strength of the 1992 year-class is not well estimated, but early indications suggest that it is moderate, comparable to those of 1983, 1985 and 1987.

The catch rates of 51 small druggers which fish for haddock on Georges Bank show an increase to 1989, a sharp decline in 1990 and low catch rates since then. Trawler effort rose substantially during 1990-1992.

##### ASSESSMENT

Canada conducts research surveys on Georges Bank in March and the U.S.A. does so in March and October. These surveys have supplied the data for stock assessment and defined the migration of haddock across the international boundary. In general, the trend is for haddock to move to the northeast and to

deeper water in summer, returning to the bank in winter. The movement does not seem to be related to fish density or abundance.

It appears that only a small fraction of the total stock moves into U.S.A. waters. However, the continued appearance of haddock on the U.S.A. side, despite high exploitation, suggests that fish from the Canadian side keep replenishing the American side, regardless of how heavily the Americans fish them. At the beginning of the spring-summer period, about 85% of the fish are normally in Canadian waters. By the beginning of the autumn-winter period, nearly all are in Canadian territory. Details of this migration are important, because the distribution of fish will heavily influence the effectiveness of conservation measures, especially if Canada undertakes them alone.

The determination of stock status is based on analysis of the commercial catch information and abundance trends from the three research surveys. The 1983, 1985 and 1987 year-classes were the most abundant since the strong 1975 and 1978 year-classes. Other year-classes have been weak. The 1992 year-class could be of moderate strength, but it is too early to estimate its abundance reliably. The adult biomass in 1993 declined under 5,000t, near the historic low of the 1970s. The fishing mortality in 1992 was the highest observed and corresponded roughly to removing 60% to 70% of the 1985 and 1987 year-classes.

## PROGNOSIS

Applying the most likely estimates of fish distribution and migration rates indicated that, for this transboundary resource, conservation measures by Canada could achieve the benefits of an  $F_{0.1}$  strategy: a stronger spawning biomass, more large fish, higher and more stable catches and a higher yield per recruit. Actions by the U.S.A. did not have an important effect. Under less favourable patterns of fish distribution and migration, Canada alone could probably not effectively manage this stock. That is, high fishing on the American side could defeat the benefits of moderation on the Canadian side. If Canadians concluded there was no point to moderation, yet the most likely patterns of distribution and migration prevailed, they would risk losing potential yield from the stock. These conclusions are based on recent patterns of haddock distribution and migration. With increased abundance, these factors could change and the conclusions could also change.

If the 1992 year-class proves to be as abundant as the 1983, 1985 and 1987 year-classes, the adult biomass will increase to about 10,000t in 1995 as it recruits to the fishery. The projected yield at  $F_{0.1}$  in 1994 would be about 2,000t, with the 1992 year-class accounting for about 70% of the landings. In the absence of any substantial standing stock, future catches are likely to fluctuate greatly in response to variable recruitment, potential yield may be lost as fish are harvested heavily as soon as they recruit to the fishery and before their growth potential is realized. In addition, there is a greater chance that undersized fish will be caught and have to be discarded.

In summary, poor recent recruitment and the severely depleted state of this stock warrant the pursuit of consistent restrictive measures by both countries to improve chances of accelerating a recovery and building up the adult biomass to levels which could sustain higher catches.

#### 4.11. POLLOCK IN 4VWX & 5Zc

##### SUMMARY

This stock has produced landings averaging about 37,000t since 1974. Catches in the 1980s were higher than average, sustained by the strong 1979 year-class. However, catches have fallen short of the TAC for three consecutive years, and fishing mortality is high. The number of fish aged four and over is about average, but the number of larger fish has declined in recent years.

The 1989 year-class could be above average, but will not contribute substantially to rebuilding the spawning biomass if fishing mortality remains high.

##### THE FISHERY

Pollock catches in this area have ranged between 25,000 and 46,000t since 1974. Landings and TAC's were stable in the late 1980s, thanks to the recruitment of strong year-classes in the first half of the decade. However, as these fish disappear, neither the mobile nor the fixed gear sector has been able to land its full quota since 1989.

Large trawlers dominate the pollock fishery in 4VW. Their catches doubled from 1974 to 1980, remained stable to 1989 and have declined since then. Small druggers predominate in 4X and 5Zc. Their landings have remained fairly stable since 1974. Landings by gillnets have declined in recent years.

Cuban and Russian vessels took 2,000t of pollock in this area in 1992, mainly as a by-catch in the silver hake fishery.

##### DATA

Pollock landings in most years are made up chiefly of three or four year-classes. In 1992, the catch of two and three-year-old pollock was the highest since the early 1980s. The 1989 year-class showed up strongly in the landings of the last two years. In 1991, it made the second largest catch of two-year-olds ever. The following year it made the third largest catch of three-year-olds.

Research vessel surveys show an increase in abundance of mature pollock in the early 1980s. Since then, results have varied widely from one year to the next, making it difficult to estimate year-class strengths. In 1992, the number of pollock aged 4-10 in the survey catch was the lowest since 1984, but the number of three-year-olds from the 1989 year-class was among the highest in 22 years.

##### ASSESSMENT

This stock was low in the early 1970s, peaked in the mid-1980s and has declined since. The 1979 year-class, which contributed to the good landings in the 1980s, numbered an estimated 76 million at age two; this was the second largest recruitment since 1974. Recruitment from 1980 to 1985 was near the long-term average of 28 million.

---

A preliminary estimate of the 1989 year-class puts it close to the record of 76 million. However, this estimate is based on only two years of catch data; a more confident estimate of the size of this important year-class will be possible as new commercial and survey catch data becomes available. In the meantime, stock projections use the long-term average of 28 million as the figure for recruitment of this group.

#### PROGNOSIS

The 1993 TAC of 35,000t implies a fishing mortality of about  $F = .55$ . To fish at the target level of  $F_{0.1}$  would require TACs of about 20,000t in 1993 and 1994. However, if the 1989 year-class proves to be as large as it appears so far, the  $F_{0.1}$  catch in 1994 could be higher.

#### 4.12. REDFISH IN THE GULF OF ST. LAWRENCE & CABOT STRAIT (4RST+3Pn(January-May)+4Vn(January-May))

##### SUMMARY

Redfish stocks tend to fluctuate widely in abundance. They are slow-growing, long-living fish, but good year-classes come along only periodically. For this reason, these strong year-classes dominate the catches while they last. The rarity of good year-classes makes it important to keep fishing mortality down, to stabilize landings and sustain the population until the next strong year-class appears.

The 1988 year-class appears to be strong, though perhaps not quite as strong as was previously estimated. However, it will not contribute to the fishery for another 3-4 years. In the meantime, the 1981 year-class cannot continue to support landings as high as those of recent years, especially those in 1992.

##### THE FISHERY

Redfish landings in this area increased steadily during the 1960s, reaching a peak of 130,000t in 1973. Landings then declined steadily to a low of 15,000t in 1978, and have climbed again since then, reaching 77,000t last year. Much of last year's increase was due to higher catches during the winter in the Cabot Strait.

TACs for the 4RST stock were introduced in 1976, but landings in the Gulf have been short of the TAC in every year but two. In 1992, CAFSAC recommended a TAC of 67,000t for a newly-defined management unit that included 3Pn and 4Vn in the Cabot Strait. However, the new management unit was not put in place in 1992. Instead flexibility in harvesting was allowed which resulted in a catch that exceeded the recommended TAC by 10,000t. In 1993, the TAC will be 60,000t for the new management unit.

##### DATA

Most of the catch in 1992 was from the 1981 year-class. Commercial catch rate data show three distinct peaks. The last one, in 1990, was the highest. However, the high catch rates since 1988 may be due to the introduction of a new midwater trawl. The catch rates of bottom trawls from May to October, when most redfish are in the Gulf and thought to be closer to bottom may be a better index of redfish abundance. This analysis also showed three peaks in the catch rates, but the one for 1990 was in line with the others.

Judging by the catch rates of recent research surveys, the abundance of fishable-sized redfish (longer than 25 cm) was about 800 million in 1990, 350 million in 1991 and 400 million in 1992. The abundance of fish smaller than 25 cm was about 1,400 million in 1990 and 1991, and dropped to 400 million in 1992. In terms of biomass, the estimate decreased by about 40% between 1990 and 1991, and by 20% in 1992.

The redfish in this area include two distinct species. One dominated the strong 1981 year-class, and the other the 1988 year-class. As the former is fished down, the other species will come to dominate redfish landings from about 1997 on.

##### PROGNOSIS

The 1981 year-class is now fully recruited into the fishery and will make up the bulk of landings for the next 3-4 years. If TACs remain at the 60,000 level, the exploitation rate will increase as the remaining biomass decreases. Catch rates will also drop, as they did when earlier strong year-classes were taken up in the 1980s. However, current landings are roughly double the catches in that period; if the year-class supporting this fishery is roughly equal to the last big year-class, the biomass will decline faster this time around, because the catches are higher.