

PUBLICATION 696
FARMERS' BULLETIN 95

ISSUED MAY, 1940
FIRST PRINTING

DOMINION OF CANADA—DEPARTMENT OF AGRICULTURE

SNOW UTILIZATION IN PRAIRIE AGRICULTURE

By G. D. MATTHEWS, Superintendent

DOMINION EXPERIMENTAL STATION

Scott, Sask.



RIDGING TO ACCUMULATE SNOW ON FIELDS

Ridges should be close, about 8 feet apart, to allow the spaces between them to be filled in with drifting snow.



Published by authority of the Hon. JAMES G. GARDINER, Minister of Agriculture,
Ottawa, Canada

630.4
C212
P 696
1940
c 2



Agriculture
Canada

Canadian Agriculture Library
Bibliothèque canadienne de l'agriculture
Ottawa K1A 0C5

CONTENTS

	PAGE
Introduction	3
Pull-type Snow-plough	5
Push-type Snow-plough	7
Type of Snow-plough to Use	12
Operation of Snow-ploughs	12
Disappearance of Snow in Spring	14
Water in Accumulated Snow	17
Weed Seeds in Drifted Snow	18
The Fertilizing Value of Water from Snow	19
Influence on Yield of Field Crops	19
Influence of Snow Conservation on Soil Moisture	21

SNOW UTILIZATION IN PRAIRIE AGRICULTURE

Introduction

Snow constitutes slightly over 25 per cent of the annual precipitation received on the Canadian prairies. According to long-term records kept at Experimental Stations on the open plains, the total snow, which usually makes its appearance early in November and remains for five months, averages 3 to 4 feet per year. The equivalent of this amount of snow in terms of rain is $3\frac{1}{2}$ to approximately 5 inches.

With the exception of areas subject to warm Chinook winds, snow on the prairies does not disappear until early spring. Most of the snow accumulates wherever an obstruction or an irregular land contour causes it to be piled up by the wind. Deep drifts collect in coulees and obstructions of any size gather snow by wind action—the amount depending on the size and shape of the object. Shelter-belts of trees accumulate the largest drifts of snow and such snow-traps have long been recognized as almost a guarantee for crops of vegetables or fruit. Summer-fallow fields are normally swept clear of snow by intermittent winds of varying velocity; therefore, the snow that falls during the winter is of little or no value in the production of crops on these fields the following summer.

It has been noted many times that accumulated snow influences growth of vegetation: scattered growths of native trees are found growing on the prairies, usually in locations where snow gathers during the winter; the heaviest growth of grass is found in the same location and early settlers cut native hay in such areas; spots in shelter-belts receiving extra snow-moisture, stand out because of their vigorous growth. When production of sheaf oats is desired to guarantee a feed supply, farmers on the prairies frequently select land where snow accumulates or to which snow-water drains in the spring. In a Miscellaneous Publication of the United States Department of Agriculture, Russel Lord, after visiting a soil conservation project at Culbertson, Montana, in 1937, states: "The most hopeful sign at first was the way in which grass shone bright that spring where snow-drifts had made mounds and melted. Elsewhere, junegrass was sparse and brown."

In spite of the striking evidence of the value of snow, practically no attempt has been made to artificially accumulate it on fields in connection with the production of field crops. In a dry season when field crops were almost a failure, practically all the vegetables at the Dominion Experimental Station, Scott, were produced in that portion of the garden which was covered with snow-drifts the previous winter. In 1936, such vegetables as carrots, parsnips and beets had five times the yield on land where snow-drifts accumulated, compared with land where snow was almost absent the previous winter. Yield of cabbage was increased fifteen times by the same method.

From a field-crop standpoint, the interesting fact was that where accumulated snow melted gradually, the surface was wet in the spring. A moist surface meant that soil-drifting control on the silty-clay loam soil on the Station would be greatly facilitated. Certain tillage practices would produce a lumpy surface which would resist soil erosion by wind. Experiments were therefore started to accumulate snow on fields.

Upon using artificial barriers such as brush or snow-fence, it was found that unless the barriers were placed close together, this procedure brought complica-

tions and, in the case of the snow-fence, the expense was too great. The trouble found by using brush or snow-fence in rows through fields, was that bare land occurred between the strips of drifts in early spring. Alternate freezing and thawing produced a layer of fine surface soil which blew off the bare strips and covered the snow-drifts before they melted, thereby giving partial insulation. Melting did not take place, therefore, until the weather became quite warm when the high temperatures caused the drifts to melt quickly, with resulting erosion as the water drained away. After the snow itself disappeared, there remained strips of very wet and strips of almost dry soil, which prevented the land being worked at a normal date in the spring.

Experimenting further with snow-fence, rows of pickets were scattered at intervals through a field and snow-fence two feet high was used which was raised on the pickets as the height of snow increased. The fence was moved on successive rows of pickets, thereby making it possible to accumulate several rows of drifts which met. Invariably this snow-cover was uneven and the expense involved did not warrant practical application of the method unless required for a specialized purpose.

Pursuing the subject further in an attempt to overcome previous difficulties, it was thought that ridges would accumulate an even snow-cover over fields. The first requirement was to build a cheap, workable, snow-plough. In the first attempts, a V-shaped structure was constructed with the side planks vertical. This ridged soft snow but where hard snow was encountered, penetration could not be successfully accomplished, and when pulled by horses, it was found by the teamster to be exceedingly difficult to ride on. Stones placed on the front to provide the necessary weight to make the plough penetrate drifted snow fulfilled their purpose but also made the nose dig into the soil. The difficulty was overcome by giving a slope to the sides and constructing a pointed nose for the plough. A workable snow-plough, designed to be pulled, was finally constructed for the ridging of snow in fields, as shown in the plan illustrated.

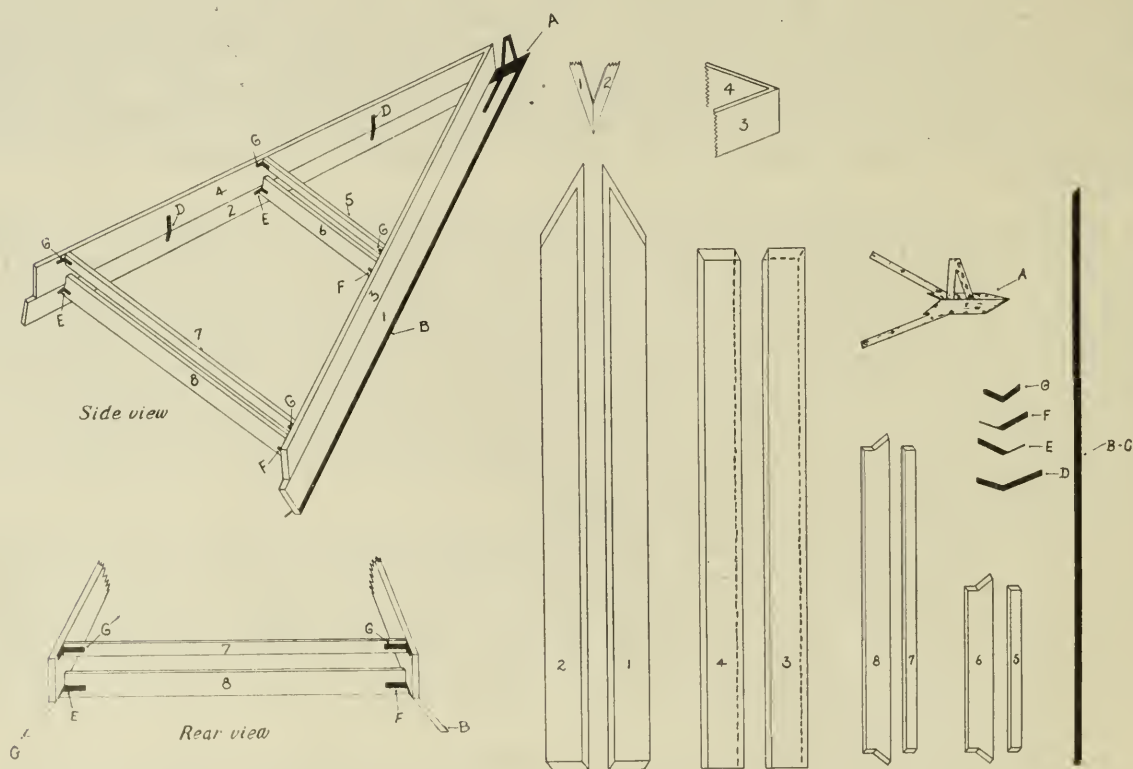

Plan of pull-type snow-plough.

PULL-TYPE SNOW PLOUGH

Lumber required

		No. of Pieces	Dimensions
Bottom frame..	fir	2	2" x 12" x 14'
Top frame..	fir	2	2" x 12" x 12'
Braces..	fir	1	2" x 8" x 12'
Braces..	fir	1	2" x 4" x 12'

FRAMING THE SNOW-PLOUGH

Square one end of 14-foot planks. Mark a point 19 inches from one end and draw a line to the opposite corner, which is a 7- by 12-inch line on the square, drawn on the plate side at 12 inches. This gives an angle of 30 degrees. A bevel cut is then made on this line at an angle of almost 20 degrees or a 4- by 12-inch line on the square cut on the plate side at 12 inches. These cuts are made so that when placed together, they match and make the bottom frame of the plough at an angle of approximately 50 degrees with the ground, on the inside. It will be noted that these planks are now sitting on edge and both the upper and lower edges must be bevelled horizontal, requiring a 10- by 12-inch line on the square, cut on the tongue side at 10 inches, which gives an angle of 50 degrees. These constitute parts 1 and 2 on the plan.

Parts 8 and 6 are now cut from the 2- by 8-inch plank. Cut a piece 7 feet, 9 inches long. Draw a line $4\frac{1}{2}$ inches from the bottom edge of the plank along one side. Make 12- by 13-inch mark with square drawing-line on the tongue side at 13 inches which gives an angle of 50 degrees. This is done on both ends of the same side up to the line $4\frac{1}{2}$ inches from the bottom edge. Bevel cuts of 70 degrees or cuts 4 by 12 inches with square drawing-line on tongue side at 4 inches are made with the two bevelled faces on the same side of the plank. These ends are then cut at this angle up to the $4\frac{1}{2}$ -inch line from the edge previously drawn. After making these cuts, lay the plank flat with the long side of the bevel up. Draw a line at right-angles to the side of the plank where the saw-cut crosses the $4\frac{1}{2}$ -inch line. Make bevel of 70 degrees as described above, on 3-inch line, with bevel in same direction as before. Part No. 6 is made the same as part No. 8, except that a piece of 2- by 8-inch is cut 4 feet $5\frac{1}{2}$ inches long to start with.

Parts 3 and 4 are now cut from the two pieces of 2-inch by 12-inch by 12 feet. Square one end of each plank. Cut on each squared end a miter $4\frac{1}{4}$ by 12 inches on the plate side at 12 inches, which will give a 20-degree angle. These form the top sides of the plough.

The top braces, parts 5 and 7, remain to be cut. For part 7, cut a length of 2 by 4, 7 feet 1 inch long, and for part 5, cut a piece 3 feet 10 inches. Bevels are made on the ends at an angle of 70 degrees as previously described.

Iron Required

Braces..	1 bar	Mild steel..	$1\frac{1}{4}$ " x $1\frac{1}{2}$ " x 16'
Shoe sides..	2 bars	"	" x 2 " x 16'
Hitch..	1 piece	Coulter steel..	$1\frac{1}{2}$ " x 2 " x 2'2"
Nose..	1 "	Fin steel..	$1\frac{1}{4}$ " x 4 " x 3'6"
Nose brace..	1 "	Mild steel..	$1\frac{1}{2}$ " x 2 " x 4'
	60	Carriage bolts..	$\frac{3}{8}$ " x $2\frac{1}{2}$ "
	16	Countersunk bolts..	$\frac{5}{16}$ " x $2\frac{1}{2}$ "

BLACKSMITH'S WORK

All the iron-work can be done in the average farm blacksmith shop, except the nose-iron and hitch combined (shown as part A). The nose is made of fin steel. First cut this material into two lengths of 20 inches. Shape the sides as shown in the diagram. Cut a V-shaped angle of 40 degrees in two blocks of wood. Invert the sides and place in these cuts. The tips are then fastened with a torch and removed from the blocks, turned over and welded along the joint. Cut the coulter steel into lengths of fourteen and twelve inches. Split one end

of each for $1\frac{1}{2}$ inches and spread to straddle the welded nose. Weld into position as shown in diagram. The wings used for braces are then cut and welded to the nose, as shown in diagram. The four holes for the hitch are $\frac{5}{8}$ of an inch and the other holes in part A are $\frac{3}{8}$ of an inch in diameter.

After Part A is attached, the shoe sides, B and C, are cut to fit flush to part A, drilled and bolted as illustrated. On parts A and B the countersunk bolts are used and it is advisable to bore the holes near the top edge of shoe. It is important to bore these holes horizontally to have as much clearance as possible to avoid unthreading bolts on the right side when snow-plough is in operation. If it is intended to use the snow-plough on land where there are surface stones, it is advisable to weld parts B and C where these fit to part A.

Four braces are made like part D, of $\frac{1}{4}$ - by $1\frac{1}{2}$ -inch mild steel. The top is 10 and the bottom, 8 inches long. These are bent at an angle of 140 degrees with four $\frac{3}{8}$ -inch holes in each before attaching, as shown in the plan. Part E is made of the same material 6 inches each way, at an angle of 130 degrees, but twisted for bracing parts 6 and 8 to part 2 on the left side. Part F is made similarly except that it is twisted to brace parts 6 and 8 to part 1 on the right side. The four braces marked G are made all the same at an angle of 130 degrees.

ASSEMBLY OF THE SNOW-PLOUGH

Choose a level spot about 15 feet square. It is necessary to assemble the wooden parts of the plough before doing the iron parts. Take parts Nos. 1 and 2. Put points together with No. 1 on right and No. 2 on left. Raise these bottom sides so as the front cuts fit exactly together, which should be tacked temporarily with some 2-inch nails. Before proceeding further, measure the spread at the ends of the sides. This should be 9 feet $4\frac{1}{2}$ inches, measured from the bottom.

Place part No. 8 in between 1 and 2, 18 inches from the end and raise it so that it fits into position. Nail in position with 4-inch spikes. Part No. 6 is now placed in between Nos. 1 and 2, about 6 feet 4 inches from the end in the same way as No. 8 was installed.

Put No. 3 on top of No. 1 in vertical position, having the bevelled end in front. Put 4-inch spikes through Part 3 into 6 and 8. Place Part 4 on top of Part 2 and follow the same directions as for No. 3.

Place No. 7 over No. 8 in between Nos. 3 and 4, even with the top, and spike in position. No. 5 is then placed in position over No. 6 in the same way as No. 7 was installed.

All the wooden portions are now in position and the snow-plough has assumed its shape. The metal parts can now be made with framing done to act as a guide. The ends of the sides of the plough look uneven because the 2- by 12-inch lengths of planks purchased were not cut as there was no advantage in doing so. After doing the blacksmithing work, the metal parts are then attached securely with bolts. The carriage bolts used for attaching part A will require to have the shoulders filed off to fit flush to the metal. To avoid warping, the plough should be oiled and painted.

COST OF MATERIALS

The lumber costs approximately \$6. If a carpenter is employed, it will take him two days. If all the metal work is done by a blacksmith, the cost would be approximately \$13, including cost of material. If part A (nose iron and hitch) is made by a blacksmith, it would cost in the vicinity of \$5. If the flat-iron and bolts are purchased separately (exclusive of materials for A), the cost would be about \$6. To have the complete snow-plough made by skilled labour, including material, the cost would be around \$25, but this figure would be reduced depending on the amount of work done on the farm.

Push-Type Snow Plough

BUILDING INSTRUCTIONS

The construction and cost of the plough will vary according to the material on hand with which to build it. Nearly all the material can be taken from discarded machinery which is to be found in many farm scrap heaps. The angle-irons and materials may be a little larger or smaller than those specified and with this leeway, little need be bought. A discarded binder, separator, or plough, will give a lot of splendid material which may be pieced together to make the plough. Although welding is recommended for the job, the plans here give details for bolted joints. If welding is available, butt joints would prove to be strong enough. The welding as specified is the minimum that can be done and make a good job. The hitch as shown will work for any type of tractor, but modifications may be made, depending on the tractor used.

Ribs.—The first things to make are the ribs. These are made of $1\frac{1}{2}$ - by $1\frac{1}{2}$ - by $\frac{1}{4}$ -inch angle-iron and are bent as illustrated in Figure 1. The nose rib is bent so that the corner of the angle-iron points forward. Side ribs (of which there are at least two) and end ribs (also two) are bent so that a flat side faces outward. If only light angle-iron is available, then extra side ribs will be necessary. The side ribs are thus bent along one side while the end ribs are bent much as the nose rib. If the end rib is bent along one edge, then it will be necessary to fill between the forward leg of the angle-iron and the sheet-covering with a strip of wood. In making these ribs, mark out the shape on the floor, using the ordinates as shown in Figure 1. At each point marked, a nail may be driven into the floor and the irons bent hot until all the nails are touching the iron. The ends of the ribs will have to be bevelled to allow a smooth surface for the sheet-iron covering. It is advisable to bore and counter-sink holes to attach the covering before assembling the frame. The curve of the side rib will require adjustment, depending on the set given the end rib.

Frame.—The frame is illustrated in Figure II. Two pieces of $\frac{1}{2}$ - by 2-inch flat-iron, 6 feet long, have one end of each cut to fit the bottom of the nose rib. The nose rib is bolted into place loosely and the angles made to have a spread of 8 feet. The nose rib is fixed so that the top end is $22\frac{1}{8}$ inches behind the tip of the lower end and then the bolts are tightened up to hold it in place. Now the end ribs are fitted into place in the same way. Then these are all bound together by bolting on the top angle-iron ($1\frac{1}{2}$ by $1\frac{1}{2}$ by $\frac{1}{4}$ inches). The top cross-member of angle-iron should be put on next to help hold the plough in shape. The side ribs are now fitted and bolted into place and the whole frame trued up.

Hitch and Assembly.—With the frame completed, it is now ready for the hitch. The hitch is made as shown in Figure III. It is mainly a rectangular frame 6 feet wide inside and about 9 feet long, depending on the tractor used. Allow lots of length. The frame can be made of heavy angle-iron, channels or I-beams. The corners are held together as shown in details F and G. From this frame, several braces go out to the frame of the plough. These are made after the plough frame is in place. Place the rectangular hitch 6 inches off the floor and move the frame into place, resting the plough frame on the floor. Then make and fit the mounting bracket for the sides of the plough, as shown in Figure III, detail F. Now make the braces to the nose piece and sides and tops of the frame. With light material, extra braces will be required. Bolt all these solidly in place. Be sure to use an eye bolt for the top bolt in the mounting bracket. These eye bolts anchor stout chains which are fastened

to the front hitch of the tractor to stop the plough from rubbing on the side of the tractor. Make the plate for the drawbar out of heavy sheet-steel (at least one-quarter of an inch thick) and bolt it in place. It is well to note here that lock washers should be used throughout. The plough should now look as shown in Figure IV.

The scraper blade and cutter knife are made as shown in Figure IV. A 1- by 1- by $\frac{1}{8}$ -inch angle-iron is bent to the same shape as the nose rib and a sheet of $\frac{1}{4}$ -inch steel also cut to this shape. The two are welded together and the scraper blades welded to them. The cutter knife should be sharpened. The cutter knife is useful to cut the hard snow but does not eliminate side pressure on the plough.

The metal covering is now applied. This may be applied in small sheets but wherever a joint occurs, it should be lapped as shown in Figure IV. It is a lap-joint backed by a 1- by $\frac{1}{8}$ -inch strap of iron. All holes are countersunk so that the tight bolt will draw up flush with the sheet. Round-head carriage bolts may be used. Narrow boards (spread a little) may be used for covering next to the ribs to support the 16-gauge galvanized iron. Metal covering is put on before bolting on the scraper blade.

Lift.—For transporting to and from fields, a lift is an essential feature. The type illustrated has worked satisfactorily but modifications of it can be used, depending on the material available. The lift skids are made so that they operate in an old bearing. By attaching a collar to them and having them operate between two other collars as shown, they are free to turn. These skids are not illustrated in correct detail and should be 30 inches long with both ends turned up like a shoe runner. Attach the shaft to the skid 8 inches from one end so that a castoring effect is produced. The lever is placed on the frame so that it is handy to the operator of the tractor. It should be a long lever. The springs which can be taken from the table of a combine or from a disk-plough, are tightened until the plough just about floats. With this setting, the operator can easily manage the lift. If the springs available are very long, a truss-work over the top of the plough may be made of angle-iron, to anchor the upper ends. A large disk may be used as runners for the lift skids.

The nose skid is non-turning but is made, as shown in Figure V, so that it may be adjusted vertically. This is necessary where the plough may be used on fields with different kinds of previous tillage. It bolts onto the mounting bracket with one $\frac{1}{2}$ -inch bolt. For most successful operation the nose skid is placed inside, just behind the point of the plough. If the plough in operation has a tendency for the wings to dig in the ground, this may be overcome by adding skids inside the corner of the wings, about 2 inches lower than the scraper blade.

The tractor is put inside the hitch by using blocks and driving over them. The drawbar is pinned to the drawbar plate and the front chains tightened to stop either side of the snow-plough from pressing on the tractor.

After operating for a short while, it will become obvious that the corners of the hitch will need bracings. These braces are best put in while the tractor is hitched up so that the danger of them interfering with the tractor will be lessened.

Material Required for Push-Type Snow-Plough

- 30 feet... I-Beam 4 inches deep, or heavy angle-iron for frame.
- 16 " " " " " " $\frac{1}{2}$ - by $2\frac{1}{2}$ -inch flat-iron for shoe and lifting device.
- 12 " " " " " " $\frac{1}{4}$ - by 3-inch flat-iron for scraper blade.
- 20 " " " " " " $1\frac{1}{2}$ - by $1\frac{1}{2}$ -inch angle-iron for ribs.
- 18 " " " " " " $1\frac{1}{2}$ - by $1\frac{1}{2}$ -inch angle-iron for frame and braces.
- 26 " " " " " " 2- by 2-inch angle-iron for braces.
- 6 " " " " " " $\frac{1}{2}$ - by 3-inch strap-iron for corner braces.
- 1 plate... 18- by 9- by $\frac{1}{2}$ -inch for draw plate.
- 50 square feet... . . . 16-gauge galvanized iron.
- 10 feet... $1\frac{1}{2}$ -inch round-iron for lever assembly.
- 3 only... Large springs to lessen lift.
- 6 feet... $\frac{1}{2}$ - by 4-inch, for runners, of sleigh-shoe steel.
- 2 only... Bearings for lifting device.
- 5 feet... 1-inch round-iron.
- 1 only... Quadrant assembly.
- 2 " " " " " " Gusset plates $\frac{1}{2}$ - by 2-inch, for lifting shaft.
- 3 feet... $\frac{3}{8}$ - by 4-inch corner braces from engine frame to plough frame.
- 3 " " " " " " $\frac{3}{8}$ - by 3-inch flat-iron for front cutter bar.
- 6 " " " " " " Half-inch chain.
- Miscellaneous bolts, washers and rivets.

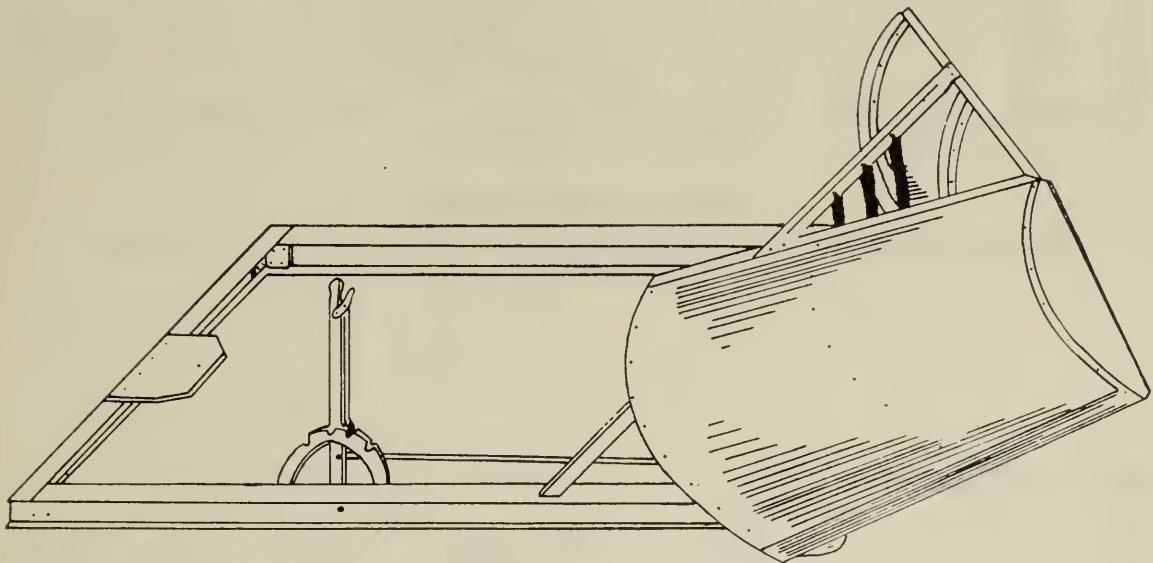

PUSH-TYPE SNOW-PLOUGH

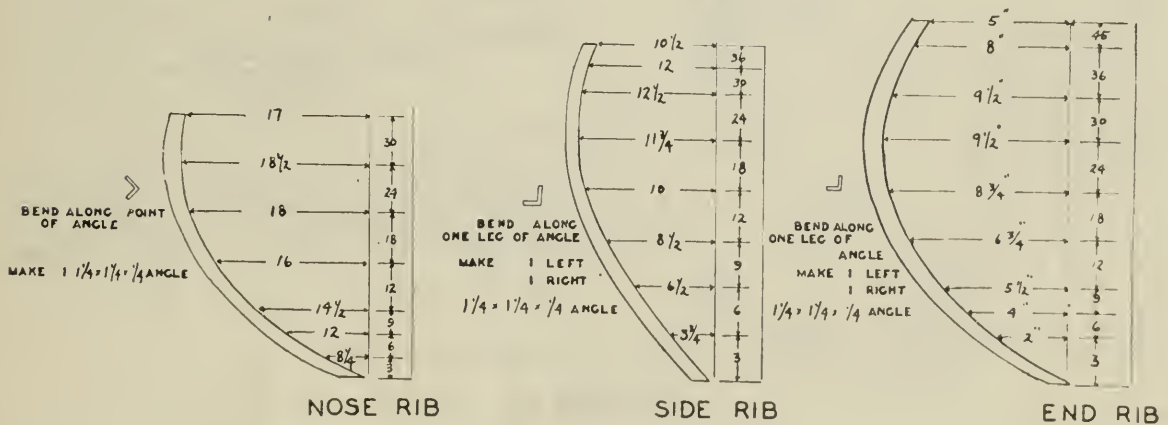

FIGURE 1

SNOW-PLOUGH FRAME RIBS

Additional ribs will be required if lighter material is used.

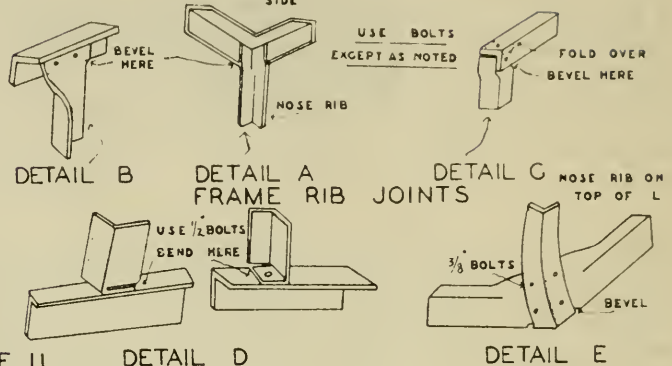
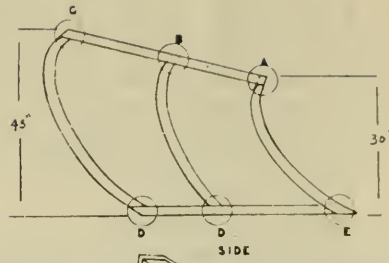
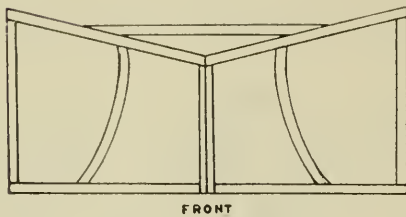
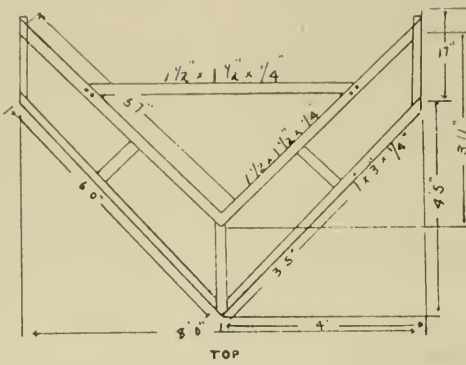

FIGURE 11

DETAIL D

DETAIL E

SNOW-PLOUGH FRAME

In Detail E, strap-iron ($\frac{1}{2}$ - by $2\frac{1}{2}$ -inch) may be substituted for the horizontal angle-iron used on bottom of frame.

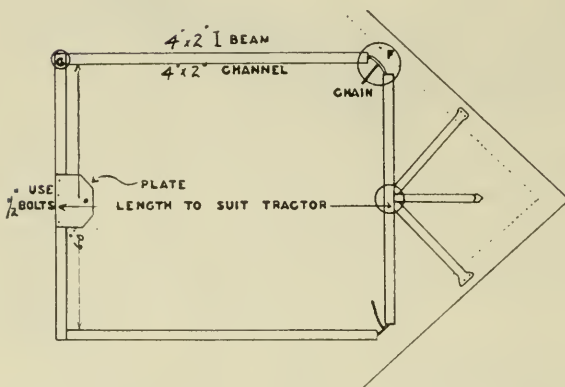

SNOW PLOUGH HITCH

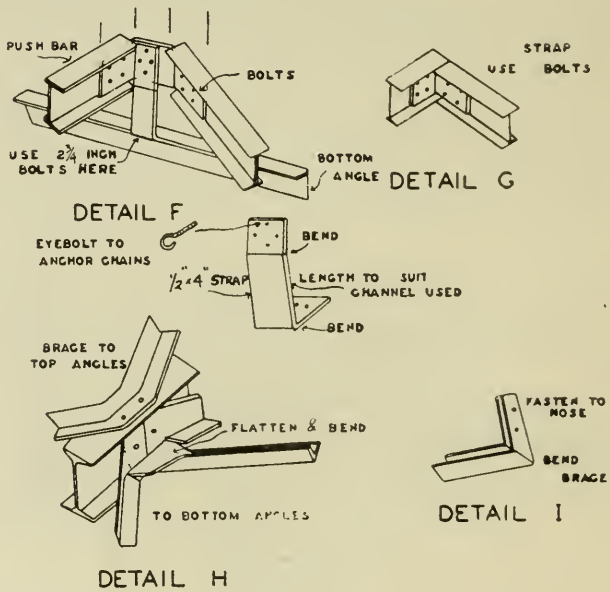

FIGURE 111

SNOW-PLOUGH HITCH

For the majority of tractors it will be necessary to cut a portion of the front corners of the push-frame and join with a short brace to allow for inward curve on sides of the plough.

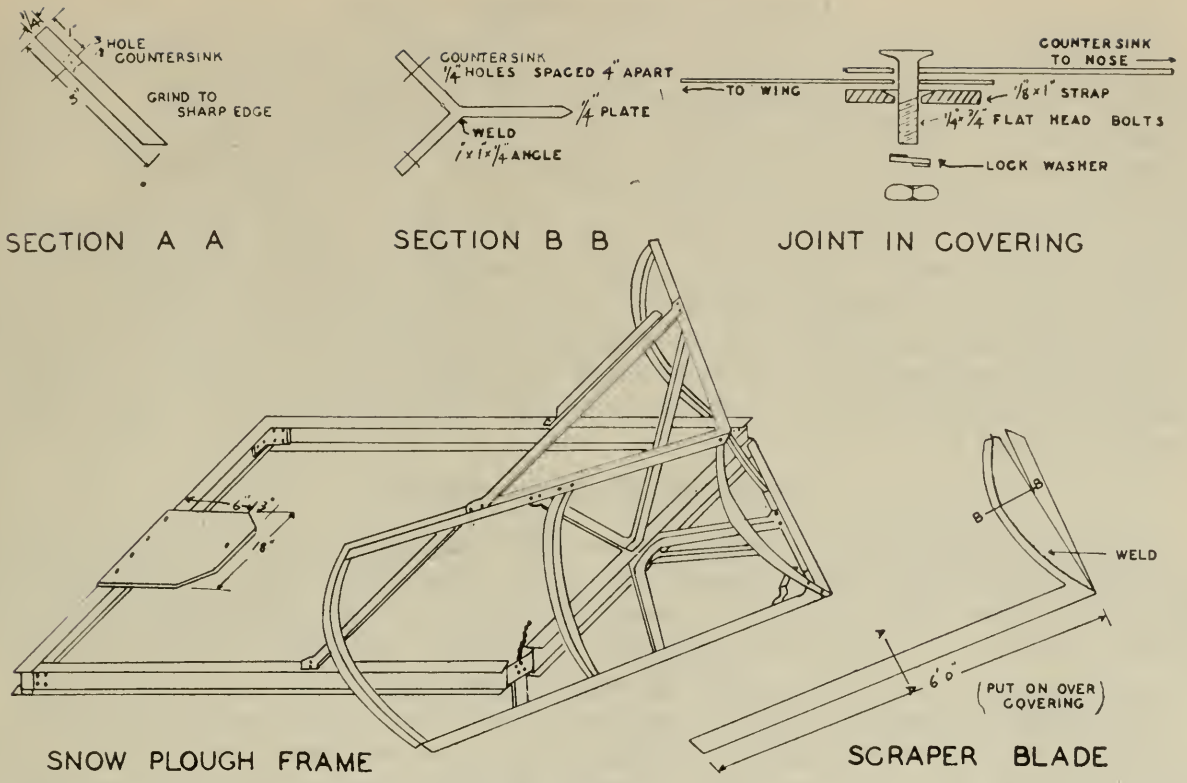

FIGURE IV

SNOW-PLOUGH FRAME

It is not necessary to have the front cutting blade the full width of the arc, as illustrated.

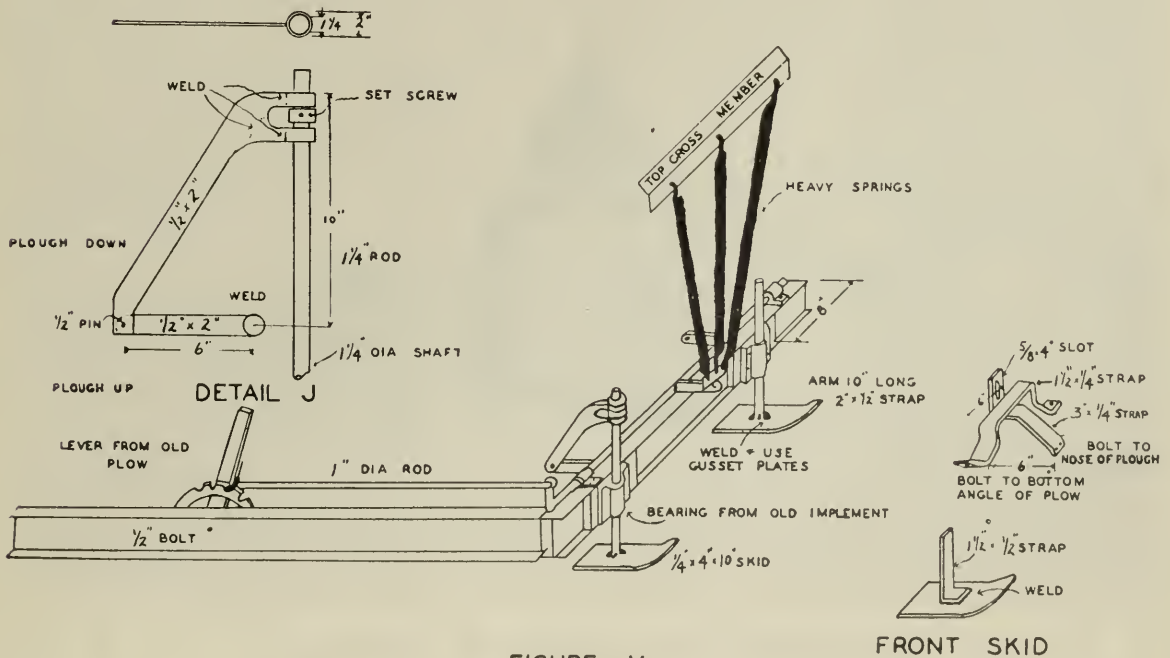

FIGURE V

LIFT FOR SNOW-PLOUGH

The shoes on which the plough is lifted must be longer and curved at both ends. See description in text. The springs illustrated in Figure V are not fastened to the bottom frame. A careful examination of the drawing shows they are attached to an arm welded to the lifting rod so as to lessen the strain on the lifting mechanism, when raising the plough.

Type of Snow-plough to Use

Plans are presented for two types of snow-ploughs designed for ridging snow with the object of accumulating a deep snow-cover on fields. For the farmer who uses only horses, the pull-type is adapted for his farm power. Both types can be used with tractors, but experience should be gained with the pull-type before going to the expense of constructing a push-type snow-plough. While inquiries have indicated a preference for a push-type plough, the pull-type is lower in cost, cheaper to operate, simpler to repair and, in most cases, may be used to accumulate sufficient snow to accomplish the desired objectives. Only after a good snow-cover has been accumulated by ridging in early winter does the construction and use of a push-type seem warranted for fields, but it is particularly useful along a drainage basin from which the snow-water is to be stored in a dam or dugout.

Operation of Snow-ploughs

Land on which snow-ploughs are to be operated must be free of surface obstructions—strong objects frozen into the ground will smash a snow-plough. Not only must surface stone be removed but any rocks projecting from the ground should be marked and avoided. Contour cultivation is recommended for sloping land on which snow-ridging is to be done.

The snow-ploughs should be ready in advance of winter, for the delay caused by waiting to construct a plough after the snow comes, invariably means that bare land will be blown free of snow. It is advisable to go over summer-fallow land first, as enough snow will usually be held in stubble after a wind to allow ridges to be thrown up. If the acreage is large, it is well to be equipped for day and night operation because wind frequently follows a calm snowfall.



A few inches of snow is sufficient to start ridges.

An early start is most important. Deep snow is not necessary—a good start can be made with snow 3 to 4 inches deep, as it is surprising how small a ridge will collect snow in open windswept areas. This is particularly true on knolls, to which special attention should be paid when snow-ridging because, if knolls are dry in the spring, soil-drifting starts there first.

The pull-type snow-plough may be operated with horses or tractor. If a tractor is used, the lugs or track is satisfactory as rubber wheels slip readily on frozen ground when there is much load. Snow-ploughs are extremely rough to ride and it has been found that runners on the bottom do not prevent swinging and have a tendency to make the plough ride over the snow. However, a little swinging is considered advantageous in the making of ridges to accumulate snow.

The direction in which to make the ridges is dependent upon the prevailing winds. (In the northern half of the prairies, the winds of agricultural importance are mainly from the northwest and southeast.) In making a decision in this respect, it would be well to study accumulated snow-banks along hedges and exposed shelter-belts. At Scott it is frequently found that a line of trees running north and south has an almost even distribution of snow on both sides, while trees running east and west have more snow on the south side. It should be pointed out that while snow beside trees is accumulated by gales or blizzards, snow is usually filled in between the ridges by the sifting action of more moderate winds. At this Station, it has worked satisfactorily to ridge snow north and south, with a pull-type plough the first time, and with a push-type plough from northeast to southwest, the second time.

Snow packs best when the temperature is either above freezing or below zero. This is more important when packing a road for motor traffic than when ridging snow in fields, as proved by the fact that snow has been ridged effectively at Scott with only a few degrees of frost and also at various temperatures down to 35 degrees Fahrenheit, below zero. Crystallization takes place when moving the snow to make ridges, which serves to hold the snow in place.

Ridges should be close together, and in designing ploughs for this work, consideration was given to this point. The pull-type snow-plough is only $9\frac{1}{2}$ feet in width, measured from the bottom sides at the back, which is the widest part. The snow falls back inside the ridges as a snow-plough is operated, leaving the ridges about 8 feet apart, which is the maximum width recommended. The idea prevails that throwing up snow-ridges 25 to 30 feet apart would be equally effective, but experimental evidence has shown the fallacy of this belief. Snow only collects a few feet beyond a low obstruction and therefore will not completely fill in the space between ridges widely separated. Snow-ploughing should be done over practically the whole field. There is a tendency to make ridges farther apart when going over a field the second time with a push-type snow-plough, but as far as construction is concerned, the distance between ridges is the same with both types of ploughs.

Usually several weeks elapse before all the ridges on a field are filled with drifted snow because snowfall on the prairies is light and winds of sufficient velocity are intermittent. After one or two storms, it is likely that only a few rows of the ridges on the windward side of the area will be filled. There is a tendency to ridge this portion a second time, resulting in a heavy accumulation of snow along one part of the field. If a second ridging is planned, it is therefore advisable to wait until the first ridging has collected snow all over the field.

The objection might be raised that there is considerable discomfort in doing this work in the low temperatures of the average prairie winter. Where tractors were used, this was overcome by using a home-made cab on the tractor. In the case of horses, this can be accomplished by making a small cab on the pull-type plough, as shown in one of the illustrations. In constructing a cab on the pull-type plough, it is advisable to place it so that the balance of the plough will not be disturbed.



A farmer improved on the pull-type snow-plough by building a cab, with heater, on it. Snow has been removed where the man is standing in order to show a wing attachment designed to throw the ridges higher.

Where difficulty is experienced in throwing up ridges with the pull-type snow-plough, due to uneven snow-cover, an attachment has been found helpful. This consists of a piece of tin shaped like the mouldboard of a plough, fastened at the end of the wings and held in position by boards attached to the plough.

In the operation of any field equipment, cost is always a consideration. In pulling two snow-ploughs with a 25 h.p. Diesel caterpillar tractor, it took 36 hours to do 260 acres with ridges 8 feet apart. The fuel consumption was 31 gallons—which meant a cost of slightly less than two cents per acre. The cost was considerably higher when a push-type snow-plough was used. It took 7 hours to do 20 acres and the cost was five cents per acre.

Disappearance of Snow in Spring

Snow disappears slowly in those areas of the Prairie Provinces not subject to Chinook winds, and the spring period having temperatures above freezing in the day and below freezing at night extends over several weeks, commencing about the middle of March and resulting, often, in bare fields by the end of that month. The melting of snow accumulated on fields by ridging has been a subject of considerable speculation but, contrary to opinion, it has been found at Scott that ridges disappear before the snow accumulated by wind between the ridges has melted.

This can be explained by the fact that snow thrown up in ridges is crystallized, permitting warm air to circulate between the particles, thus accelerating melting, while between the ridges, the snow lies like a blanket of compact, fine particles, which does not melt so quickly as spring approaches. An effort was made in the spring of 1939 to record measurements on the disappearance of snow, as presented in Table 1.

It has been assumed by McColly, when writing in the issue of *Agricultural Engineering* for October, 1939, that soil must be tilled in the fall to receive moisture from melting snow. The extent of absorption of snow-water in the soil and amount of run-off, if any, is determined by the rate of thawing and the evenness of snow distribution. At Scott, where snow has been conserved by ridging on sod, stubble and fallow, no run-off water has been evident under the prevailing slow rate of melting, and even on a three per cent slope on sod, there has been no run-off.

TABLE 1.—DISAPPEARANCE OF SNOW IN SPRING

Date, 1939		Natural snow-drifts	Snow in ridges	Snow between ridges
		In.	In.	In.
March	17.....	14.0	21.0	21.5
	18.....	14.0	21.0	21.5
	20.....	13.5	20.5	21.0
	21.....	13.0	20.0	20.0
	22.....	12.0	19.5	19.0
	23.....	10.0	17.5	17.5
	24.....	9.0	16.0	17.0
	25.....	9.0	16.0	17.0
	27.....	8.5	15.5	16.5
	28.....	6.5	14.0	16.0
	29.....	6.0	13.0	15.0
	30.....	3.5	9.5	13.0
	31.....	0.0	7.0	11.0
	April	1.....		3.5
3.....			0.0	6.5
4.....				5.5
5.....				5.5
6.....				5.5
7.....				
8.....				
10.....				2.5
11.....				2.5
12.....				2.0
13.....				1.0
14.....				0.0

Actually the melting of snow starts before maximum temperatures indicate thawing weather due to the fact that official maximum recordings are made in the shade while snow, in open fields, is exposed to warmer sun temperatures. The period in the spring when snow is melting is therefore longer than official meteorological records would indicate. During the spring of 1939, from March 18 to April 14, inclusive, readings were made at Scott to compare temperatures



As spring advances slowly, ridges disappear in advance of snow accumulated between the ridges.

in the shade and in the sun, which show that the surface of the snow was exposed to an average of almost eleven degrees warmer than maximum shade temperatures. The daily difference in sun and shade temperatures varies according to the hours of sunshine and the velocity of the wind, as shown in Table 2.

TABLE 2.—SPRING WEATHER IN RELATION TO DISAPPEARANCE OF SNOW.

Date, 1939	Minimum Air Temperature	Maximum Shade Temperature	Maximum Sun Temperature	Hours Sunshine	Wind Velocity, Average 8 a.m. to 6 p.m.
March 18.....	5.6	39.6	48.0	4.6	9.7
19.....	17.4	33.3	55.0	4.8	13.2
20.....	20.3	42.0	64.8	7.5	5.2
21.....	22.0	44.5	61.6	6.4	5.3
22.....	26.0	45.2	59.8	7.6	6.5
23.....	31.5	40.3	53.6	5.9	6.9
24.....	27.7	29.4	33.4	1.2	8.0
25.....	23.8	33.0	33.2	9.0	34.1
26.....	7.2	26.1	42.5	8.8	4.0
27.....	17.4	37.3	43.0	6.0	16.1
28.....	22.6	41.7	56.2	6.0	11.7
29.....	24.7	45.5	53.2	0.0	16.1
30.....	30.3	45.2	50.6	7.4	18.2
31.....	26.0	46.2	63.0	6.1	4.8
April 1.....	30.5	45.0	54.0	9.3	23.3
2.....	28.0	29.4	34.6	3.1	8.9
3.....	25.0	38.9	43.1	0.8	26.0
4.....	9.0	16.2	31.1	7.2	29.6
5.....	7.6	23.0	35.7	7.9	24.4
6.....	17.4	41.1	50.3	7.8	15.4
7.....	19.5	38.7	50.5	10.5	6.7
8.....	27.6	37.0	49.2	4.4	9.5
9.....	28.1	45.0	56.3	0.0	22.7
10.....	14.5	22.5	37.8	7.8	13.6
11.....	12.6	37.0	38.7	10.5	11.5
12.....	22.0	44.0	54.0	11.8	22.2
13.....	23.5	53.6	68.6	11.0	5.4
14.....	24.5	65.5	69.3	10.3	11.9
Means.....	21.2	38.8	49.7	6.6	14.0

The practice of ridging snow to accumulate a deep, even cover does not prevent the frost from entering into the soil. On February 3, 1939, on land that had been snow-ploughed, the depth of snow was 12½ inches, but in spite of this, frost had penetrated the soil to a depth of 14 inches, while in another portion of the same field, where the snow was 7 inches in depth and had been undisturbed, the frost had penetrated only 11 inches. At the end of March, after a second ridging, in an area where the snow was over 2 feet deep, the ground below was frozen to a depth of 61 inches.

Frozen soil temperatures are not necessarily as low as cold winter air temperatures. On February 16, 1939, when the minimum air temperature was 46.8 below zero, the soil temperature at a depth of 4 inches, was 16.9; at 8 inches, 19.5; and at 24 inches, only 29.5 degrees Fahrenheit. On March 22, when snow had started to melt, the soil temperature at 4 inches had risen to 32.9 degrees F., and at 8 inches, 30.2, but at the 24-inch depth the temperature still remained at 29.5. This is stated to show that water from a slowly-melting, even snow-cover does not have difficulty in penetrating ground frozen during the winter and with the long melting-period, can enter the soil. Even as late as March 31, when snow disappearance was quite rapid, due to warm day temperatures, water which collected in shallow depressions during the day soaked into the ground overnight, leaving only a thin layer of white ice where

it had been. At this date, there was from 5 to 6 inches of surface soil which was completely saturated and turned to mud. The increase in the moisture-content of soil where fields were ridged with snow is presented in Table 7.

Water in Accumulated Snow

For purposes of compiling official records, 10 inches of snow is considered equal to 1 inch of rain. As this has reference to light snow as it falls, determinations were made of water in snow accumulated on fields by ridging, because this becomes packed and hard under prairie conditions.

TABLE 3.—MOISTURE CONTENT OF SNOW.

	In ridges	Between ridges	Snow Fenced	Natural snow- drifts
BEFORE PERIOD OF ABOVE-FREEZING TEMPERATURES—				
Average depth of snow in inches.....	24.0	19.4	38.3	12.4
Water present in inches.....	7.4	4.8	14.6	3.7
Inches of snow per inch of water—				
Top half.....	3.3	3.2	2.4	2.9
Bottom half.....	3.2	3.5	2.9	4.0
Average.....	3.3	3.4	2.7	3.5
Inches of water per foot of snow—				
Top half.....	3.6	3.8	5.0	4.1
Bottom half.....	3.8	3.4	4.1	3.0
Average.....	3.7	3.6	4.6	3.6
AFTER PERIOD OF ABOVE-FREEZING TEMPERATURES:				
Average depth of snow inches.....		13.5		
Water present in inches.....		5.6		
Inches of snow per inch of water—				
Top half.....		2.4		
Bottom half.....		2.4		
Average.....		2.4		
Inches of water per foot of snow—				
Top half.....		5.0		
Bottom half.....		5.0		
Average.....		5.0		



Sampling of snow accumulated on fields showed there was 3.6 inches of water per foot of snow.

One of the surprising results from this study is the amount of moisture in accumulated snow: 24 inches of compact snow, melted and absorbed into the soil, would give the equivalent of 7 inches of rain. As spring advanced, it was found that the water content of the snow increased and although the depth was less, the total amount of water in the snow remained practically constant, indicating that the snow moisture did not evaporate.

Weed Seeds in Drifted Snow

The figures presented in Table 4 show some interesting data concerning weeds in drifted snow. The numbers per cubic foot of snow are quite low, especially in artificial drifts. This is a marked contrast to the procedure of allowing weeds to grow and mature on summer-fallow in order to collect snow during the winter.

TABLE 4.—WEED SEEDS IN DRIFTED SNOW

Kind of Weed	Location in drift	Numbers per cubic foot			
		In ridges	Between ridges	Snow-fence drifts	Natural snow-drifts
Stinkweed.....	Top half.....	1.44	0.00	0.00	0.00
	Bottom half.....	1.44	0.77	0.00	0.00
Wild Buckwheat.....	Top half.....	1.44	0.00	0.00	0.00
	Bottom half.....	5.76	2.31	4.74	13.93
Blue Burr.....	Top half.....	1.40	0.77	0.00	0.00
	Bottom half.....	0.00	0.00	0.00	0.00
Lamb's Quarters.....	Top half.....	1.44	3.85	1.58	11.94
	Bottom half.....	11.52	6.15	17.38	25.87
Redroot Pigweed.....	Top half.....	0.00	0.77	0.00	1.99
	Bottom half.....	0.00	0.00	0.00	7.96
Peppergrass.....	Top half.....	0.00	0.00	1.58	1.99
	Bottom half.....	0.00	2.31	1.58	0.00
	Average.....	2.04	1.41	2.24	5.30

Natural snow-drifts ranked highest in weed-seed content with 5.3 per cubic foot—drifts accumulated by snow-fence had about half as many. There was an average of two per cubic foot to be found in ridges but an average of less than one and a half in snow drifted between the ridges. The practice of accumulating snow on fields by ridging does not accumulate weed seeds on the land, according to these figures. Not only did the snow between the ridges contain the smallest number of weed seeds but in nearly all cases the concentration was greatest in the bottom half of the drifts. Natural snow-drifts averaged eight weed seeds per cubic foot in the bottom half of the drift and slightly over two and a half in the top portion. Snow-fence, with practically all its weed seeds in the bottom half, had about half the concentration to be found in the bottom half of natural drifts. There was an average of over three weed seeds per cubic foot found in the bottom half of ridges with less than one in the top half. Snow accumulated between the ridges had an average of less than two per cubic foot in the bottom half and there was a corresponding reduction in the top portion, when compared to the ridges.

The kind of weed seeds present would, of course, depend on those prevalent in a given district. The tall weeds with strong stems were the type found in the top parts of drifts accumulated during the winter.

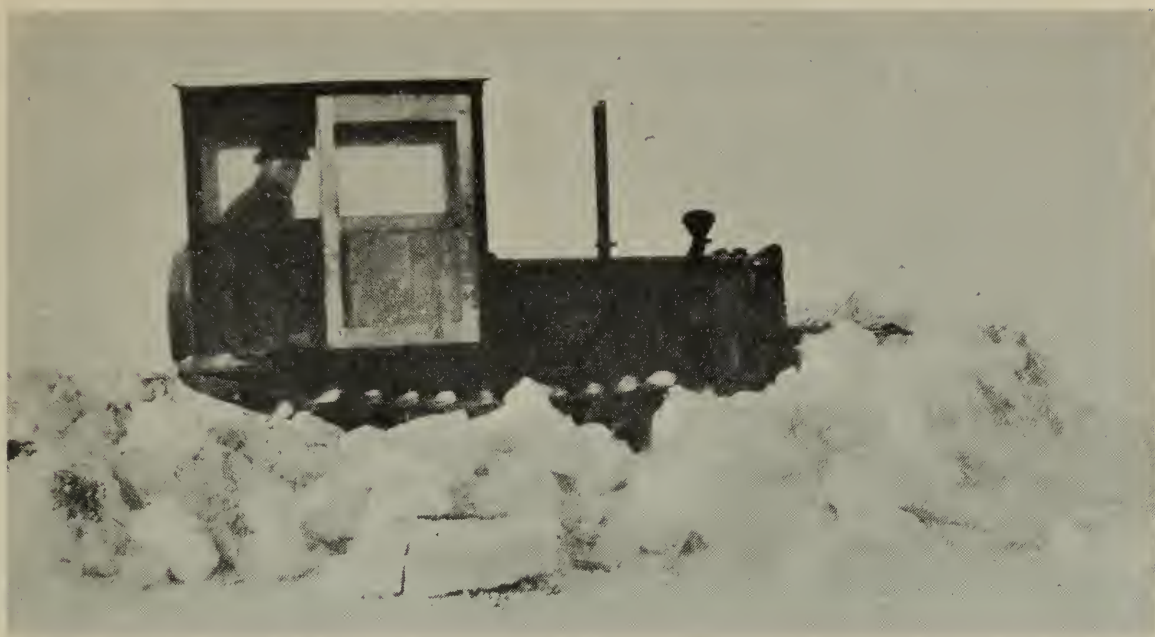

A second ridging may be done with a push-type snow-plough to make ridges several feet high.

The Fertilizing Value of Water from Snow

When determining the amount of moisture in the snow, some snow-water was retained and analysed for percentage nitrogen content. The results of this analysis are presented in Table 5.

TABLE 5.—NITROGEN IN SNOW

Date of Sampling	Location of snow	Parts per million		
		In ridges	Between ridges	Natural snow-drifts
March 20.....	Top half.....	0.452	0.593	
	Bottom half.....	1.465	0.609	
March 31.....	Top half.....		0.354	0.222
	Bottom half.....		0.447	1.316

The increase in nitrogen in the bottom half of ridges and natural drifts is a result of organic matter moved in starting the ridges or blown by the wind early in the winter. The top portions more nearly represent the nitrogen content of natural snow, which is so small as to have practically no fertilizing value from a crop standpoint.

Influence of Yield on Field Crops

Yield data were obtained in 1938 with wheat on summer-fallow that had been snow-ridged the previous winter. In 1939, comparative yields were obtained of wheat, oats, barley and crested wheat grass hay, in an experiment where one-half of each field was snow-ridged and the other half left untouched for comparison. The results are presented in Table 6.



Note first ridges made with pull-type snow-plough in foreground filled level with drifted snow. The rough area shows a portion of field which has just been ridged a second time with a push-type snow-plough.

The yield of wheat on summer-fallow was influenced more in 1938 than in 1939, as a result of snow conservation. This may be explained by the fact that the season of 1938 was preceded in 1937 by a dry fall, whereas fall weather in 1938 was comparatively wet.

Any influence from snow conservation that might be expected, with heavy stands of grain following June rains, was offset in 1939 by a hot, dry July which exhausted available soil moisture. The slight increase in yield of oats on stubble becomes puzzling when compared with a larger decrease in the yield of barley. Considerably more information is needed before any conclusions can



Ridges wide apart (25 feet) do not fill level with drifting snow.

TABLE 6.—RIDGING SNOW IN RELATION TO CROP YIELDS

Crop	Year	Land	Yield per acre		
			Snow-ploughed	Not snow-ploughed	Increase or decrease
			Bu.	Bu.	Bu.
Wheat.....	1938	Summer-fallow...	17.9	15.6	2.3
Wheat.....	1939	Summer-fallow...	15.6	15.4	0.2
Oats.....	1939	Stubble.....	46.1	43.4	2.7
Barley.....	1939	Stubble.....	25.6	29.6	-4.0
Crested wheat grass.....	1939	Sod.....	4,113 lb.	2,519 lb.	1,594 lb. Hay

be drawn, but these preliminary figures are presented because prairie farmers think of snow conservation on fields in terms of yields of grain. In an early-maturing hay crop like crested wheat grass, which requires spring moisture for a good crop, snow-ridging greatly increased the yield. Pasture in spring would be similarly influenced in increasing the feed supply, which is one of the most important needs of the prairie farmer.

An explanation of the increased yield of crested wheat grass will be found in the soil-moisture increase percentages contained in Table 7.

Influence of Snow Conservation on Soil Moisture

TABLE 7.—INFLUENCE OF SNOW CONSERVATION ON SOIL MOISTURE

Crop	Year	Land	Percentage increase in soil moisture				
			0-6"	6"-12"	12"-24"	24"-36"	Average
			Wheat.....	1938	Summer-fallow...	22.8	16.7
Wheat.....	1939	Summer-fallow...	12.5	14.3	10.5	12.8	12.5
Oats.....	1939	Stubble.....	17.7	11.9	11.2	0.0	10.2
Barley.....	1939	Stubble.....	27.0	7.8	32.3	35.6	25.7
Crested wheat grass...	1939	Sod.....	45.9	25.2	54.0	10.4	33.9

These figures were obtained by drawing replicated samples, at the four depths shown, from both the snow-ridged half and the check half of each field in the experiment, yields from which are quoted in Table 6. The figures shown in Table 7 represent, in percentage, the moisture increase of the snow-ridged portion of each field over the check. The soil samples taken, totalling 162, were drawn in early spring. As compared with 1938, available moisture in the land was higher in the spring of 1939 because of comparatively heavy rains the previous fall, whereas only light precipitation was received in the fall of 1937. When Table 7 is studied in conjunction with the yields quoted in Table 6, the increased yield of crested wheat grass is explainable by the increased soil moisture but the influence of snow-ridging on yield of grain crops is puzzling.

The value of snow conservation is quite well known in the case of vegetables and the method of accumulating snow by ridging indicates that hay yields can be increased. The soil moisture increase in spring by this method does not always increase the yield of grain but serves to definitely facilitate the control of soil-drifting. Snow utilization, therefore, offers help in solving three major problems of the prairie farmer: growing a supply of vegetables, production of feed and control of soil-drifting.

CAL/BCA OTTAWA K1A 0C5



3 9073 00187982 6

EXPERIMENTAL FARMS SERVICE

PERSONNEL

DIRECTOR, E. S. ARCHIBALD, B.A., B.S.A., LL.D., D.Sc.

ASSOCIATE DIRECTOR, E. S. HOPKINS, B.S.A., M.S., Ph.D.

Dominion Field Husbandman.....	E. S. Hopkins, Ph. D. (Acting)
Dominion Horticulturist	M. B. Davis, B.S.A., M.Sc.
Dominion Cerealist	L. H. Newman, B.S.A., D.Sc.
Dominion Animal Husbandman.....	G. W. Muir, B.S.A.
Dominion Agrostologist	T. M. Stevenson, Ph.D.
Dominion Poultry Husbandman.....	George Robertson.
Chief, Tobacco Division.....	N. T. Nelson, B.S.A., M.S., Ph.D.
Dominion Apiarist	C. B. Gooderham, B.S.A.
Chief Supervisor of Illustration Stations	J. C. Moynan, B.S.A.
Economic Fibre Specialist.....	R. J. Hutchinson.

ALBERTA

Superintendent, Experimental Station, Lacombe, F. H. Reed, B.S.A.
Superintendent, Experimental Station, Lethbridge, W. H. Fairfield, M.Sc., LL.D.
Superintendent, Experimental Sub-station, Beaverlodge, W. D. Albright.
Superintendent, Experimental Sub-station, Fort Vermilion, A. Lawrence.
Officer in Charge, Range Experiment Station, Manyberries, H. J. Hargrave, B.S.A.

BRITISH COLUMBIA

Superintendent, Experimental Farm, Agassiz, W. H. Hicks, B.S.A.
Superintendent, Experimental Station, Summerland, R. C. Palmer, M.S.A.
Superintendent, Experimental Station, Windermere, R. G. Newton, B.S.A.
Superintendent, Experimental Station, Sidney, E. M. Straight, B.S.A.
Superintendent, Experimental Sub-station, Smithers, K. McBean, B.S.A.

MANITOBA

Superintendent, Experimental Farm, Brandon, M. J. Tinline, B.S.A.
Superintendent, Experimental Station, Morden, W. R. Leslie, B.S.A.

SASKATCHEWAN

Superintendent, Experimental Farm, Indian Head, W. H. Gibson, B.S.A.
Superintendent, Experimental Station, Rosthern, F. V. Hutton, B.S.A.
Superintendent, Experimental Station, Scott, G. D. Matthews, B.S.A.
Superintendent, Experimental Station, Swift Current, L. B. Thomson, B.S.A.
Superintendent, Experimental Station, Melfort, M. J. McPhail, B.S.A.
Superintendent, Forest Nursery, Station, Indian Head, N. M. Ross, B.S.A., B.F.
Superintendent, Forest Nursery Station, Sutherland, James McLean.

NEW BRUNSWICK

Superintendent, Experimental Station, Fredericton, C. F. Bailey, B.S.A.

NOVA SCOTIA

Superintendent, Experimental Farm, Nappan, W. W. Baird, B.S.A.
Superintendent, Experimental Station, Kentville, A. Kelsall, B.S.A.

PRINCE EDWARD ISLAND

Superintendent, Experimental Station, Charlottetown, J. A. Clark, M.S.A., D.Sc.
Superintendent, Experimental Fox Ranch, Summerside, G. E. Smith, B.A.Sc., D.Sc.

ONTARIO

Central Experimental Farm, Ottawa.
Superintendent, Experimental Station, Kapuskasing, S. Ballantyne.
Superintendent, Experimental Station, Harrow, H. F. Murwin, B.S.A.

QUEBEC

Superintendent, Experimental Station, Cap Rouge, C. E. Ste Marie, B.S.A.
Superintendent, Experimental Station, Lennoxville, J. A. Ste Marie, B.S.A.
Superintendent, Experimental Station, Ste Anne de la Pocatière, J. R. Pelletier, B.S.A., M.S.
Superintendent, Experimental Station, Normandin, A. Belzile, B.S.A.
Superintendent, Experimental Station, Farnham, R. Bordeleau, B.S.A.
Superintendent, Experimental Station, L'Assomption, J. E. Montreuil, B.S.A.
Officer in Charge, Experimental Sub-station, Ste Clothilde de Chateauguay, F. S. Browne, B.S.A.

OTTAWA
J. O. PATENAUDE, I.S.O.
PRINTER TO THE KING'S MOST EXCELLENT MAJESTY
1940