

Towards Greener Munitions with less Environmental Impacts: The RIGHTTRAC Project

Sylvie Brochu
DRDC Valcartier

Human and Environmental Toxicology of Munitions-
Related Compounds – from Cradle to Grave, April
2011, Amsterdam, The Netherlands

Defence R&D Canada - Valcartier

SL 2011-543

April 2011

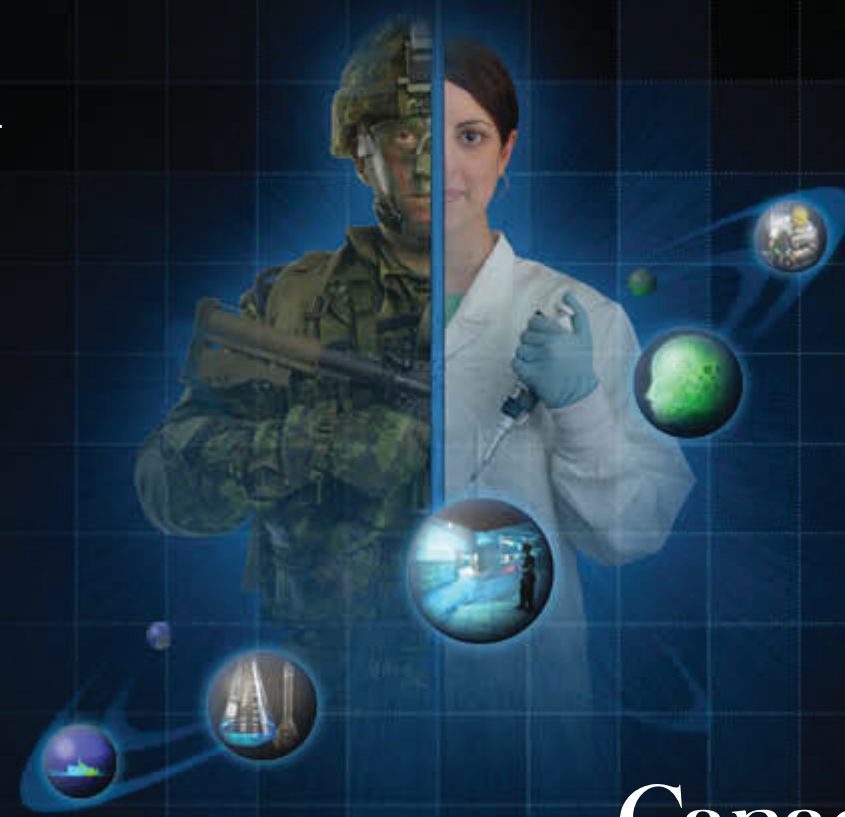

Acknowledgements

Co-authors

- M. Brassard
 - G. Ampleman
 - S. Thiboutot
 - I. Poulin
 - E. Diaz
 - P. Brousseau
 - F. Côté
 - F. Petre
 - L.-S. Lussier
- DND Director General Environment
 - General Dynamics OTS – Canada
 - Biotechnology Research Institute (NRC Canada)
 - INRS-ETE (University of Quebec)
 - Centre de Recherche Industrielle du Quebec

POC: sylvie.brochu@drdc-rddc.gc.ca

Overview

- Issues in Range and Training Areas (RTAs)
- Revolutionary Insensitive, Green and Healthier Training Technology with Reduced Adverse Contamination (RIGHTTRAC) Concept
 - Fuzing System
 - Explosive Charge
 - Gun Propellant System
 - Environmental Properties
 - IM Properties
 - Life-cycle costing
- Conclusions

Issues/Problematic

Impact Areas

- **RDX** (Most used explosive)
 - The most mobile through the soil profile
 - Migrates to groundwater and contaminates surrounding areas
- **Toxic heavy metals** (fuze, shell, propellant...)
- **Sources:**
 - Low-order detonations
 - Blow-in-place of UXO
 - Corrosion or rupture of UXOs



Firing Positions

- Significant amounts of propellants were detected
- Some of the constituents are **toxic** for the environment and **carcinogenic** for the users. (eg. 2,4-DNT, NG, phthalate derivatives, ethyl centralite, heavy metals, etc.)
- **Sources:**
 - Incomplete combustion of propellants
 - Open burning of excess propellant



RIGHTTRAC Concept

More reliable
fuzing systems
with self destruct
mechanism

Green/IM
propellant

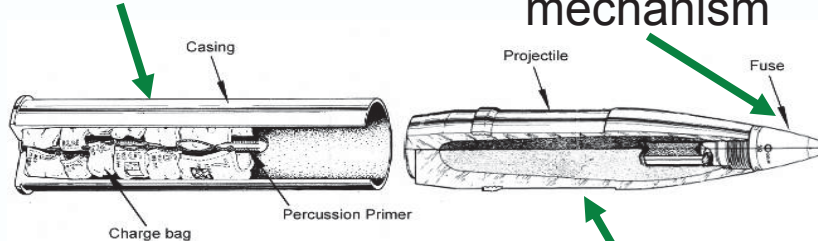

Green/IM
explosive

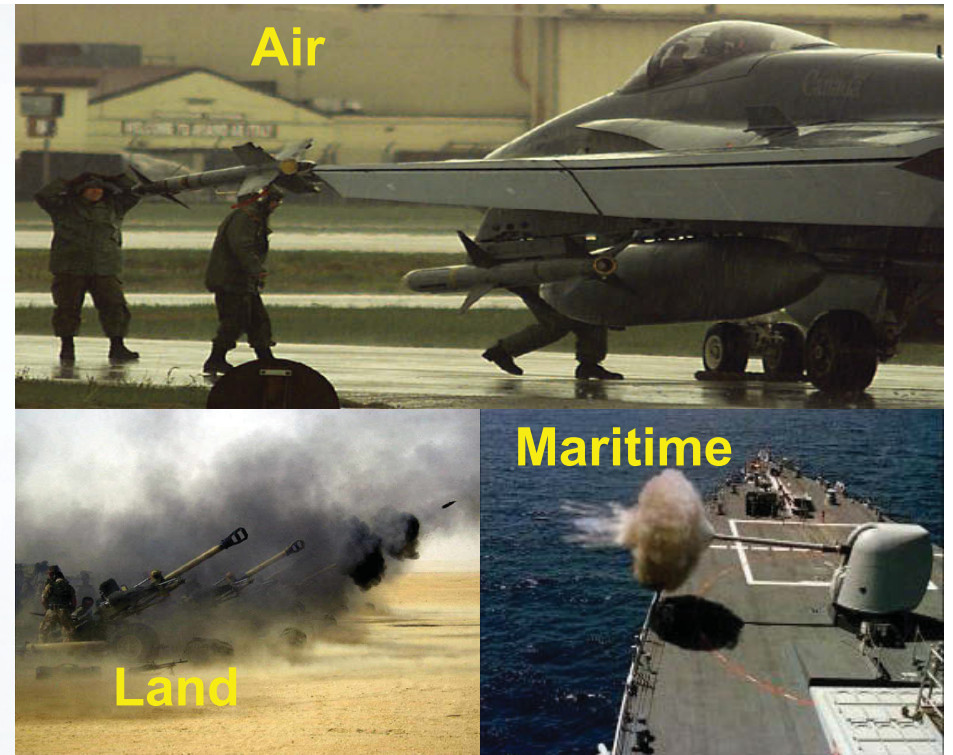

Objectives: To demonstrate that Green / IM munitions have better properties than current munitions with the benefit of decreasing the environmental pressure, health hazards, and achieving IM munitions for use in operations.

Technologies:

- Replace toxic and/or environmentally-damageable components of explosive and gun propellant by green, insensitive and recyclable compounds;
- Reduce the dud rate by including a self-destruct mechanism in a fuze
- 4 • Technology transferable to other calibers.

Fuzing System

- Development of a self-destruct capability to current artillery fuzing system in case of a failure of the primary fuze:
 - Operator handling
 - Soft impacts
 - Age-related failures
- Implementation in the existing C32A1 multi-options fuze artillery (MOFA) and/or the point detonating mechanical (PDM) 739.
- Reduce the actual live fire dud rate from approximately 5% overall to less than 1%;

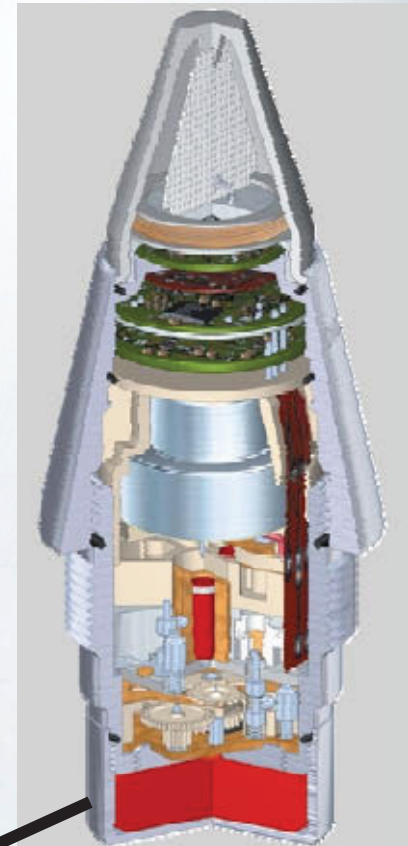
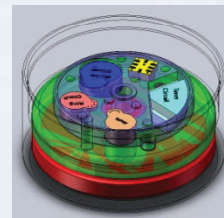

Explosive Charge – Booster (WBS 5.2.1)

✓ Preselection:

- PBXN-5 (95% HMX, 5% Viton)
- PBXW-14 (60% TATB, 35% HMX, 5% PTFE or Viton A)
- PBXN-9 (92% HMX, 2% HyTemp, 6% DOA)
- A5 (99% RDX) (current)

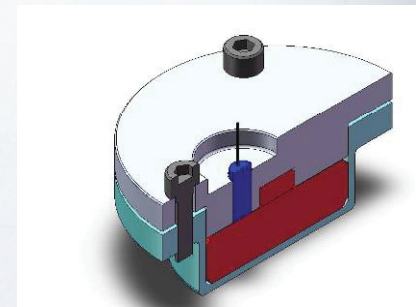

Selection (July 10)

- Data on S3 (MSIAC¹)
- Environmental properties (literature)
- ✓ Tests were done to verify if A5 would work with reduced booster size – Successful
- ✓ Simulation of booster in center and near-center axis
 - ✓ Results support all tests
- ✓ PBXN-5 was selected

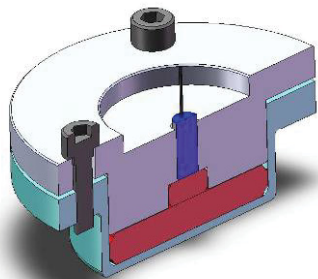

¹ Munitions Safety Information Analysis Center

Main Explosive Charge Preselection (WBS 5.2.2)

- ✓ GIM (9% ETPE, 51% HMX and 39% TNT)
 - Green compliance = *High*; IM compliance = *High*
- ✓ CX-85 (10% HTPB, 5,5% DOA, 84% HMX)
 - Green compliance = *High*; IM compliance = *High*
- NTO rejected
 - Green compliance = *Low*; IM compliance = *High*
 - High solubility (49 g/L)
 - Ecotoxicity on NTO precursors (BAE)
 - No data on environmental fate of degradation products or carcinogenicity
- DNAN rejected
 - Green compliance = *Very Low*; IM compliance = *High*
 - High toxicity

Compound	Solubility	LD ₅₀ (rat)
	mg/L	mg/kg
RDX	40-60	100
HMX	6	6000
TNT	130	794-1320
DNAN	276	199
NTO	49 000	> 5000
Comp B		197

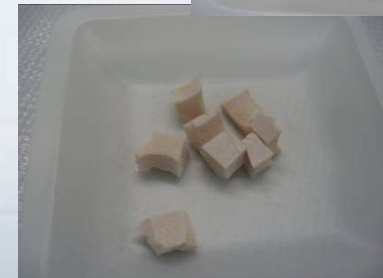

Selection
March 2011

Main Explosive Charge Performance Measurements

Performance tests (Plate dent tests coupled with Velocity of Detonation measurements)

	Density (g/cm ³)	VoD (m/s)	Relative VoD (% Comp. B)	Detonation Pressure (calc) (GPa)	Relative P _{CJ} (% Comp B)	Plate dent (cm)	Relative perf. (% Comp. B)
CX-85	1.61	8159	103	26.8	102	0.71 ± 0.01	90
GIM	1.67	7726	97	24.9	94	0.76 ± 0.01	96
Comp. B	1.68	7931	100	26.4	100	0.79 ± 0.01	100

VoD = Velocity of Detonation

- CX-85 under performs in plate dent tests.
- Candidates very close or better than Comp B in VoD and detonation pressure.
- Candidates as good as any other known IM explosive.

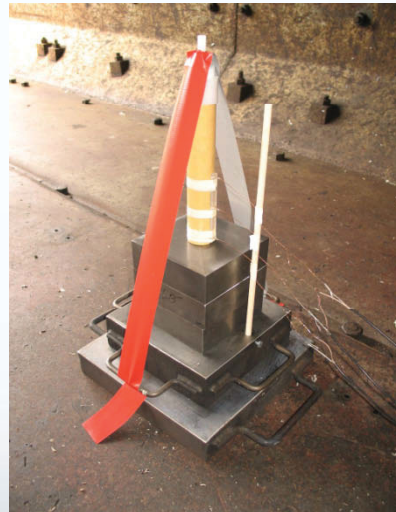

RIGHTTRAC – Gun Propellant (WBS 5.4)

- Down-selected 3 candidates
 - “Green” M1 propellant (MM1)
(DNT, DBP and DPA free)
 - Modified triple base propellant (TB)
 - Modified HELOVA
(HMX-based propellant with ETPE
and energetic plasticizer)
 - Modified LOVA
(HMX-based propellant with NC and CAB)

Mech. Properties



Selection
May 2011



RIGHTTRAC – Performance of Gun Propellant

Sample	Relative Young's modulus	Relative quickness (%)	Relative force (%)	Linear burning rate (mm/s)	Pressure exponent
Current M1	100	100	100	81	0.70
MM1	103	81	97	85	0.74
TB	28	86	103	45	0.74
HELOVA	24	101	131	73	0.84
LOVA	96	95	123		

- ✓ HELOVA showed the best ballistic performance, but the worst mechanical properties (cracking of the grains at low temperature)
- ✓ HELOVA was replaced by LOVA, based on NC, HMX, ATEC and CAB
 - ✓ Two ingredients were discarded: TEGDN and ETPE
- ✓ Fine tuning of formulations using a design of experiments was done to optimize the ballistic and mechanical properties for LOVA
- ✓ Impact: Potential 6 months delay (briefing note)
- ✓ Downselection of two formulations: Green M1 and LOVA
- Tests ongoing at BRI and INRS to verify the solubility kinetics and toxicity of LOVA

Environmental assessment of energetic formulations

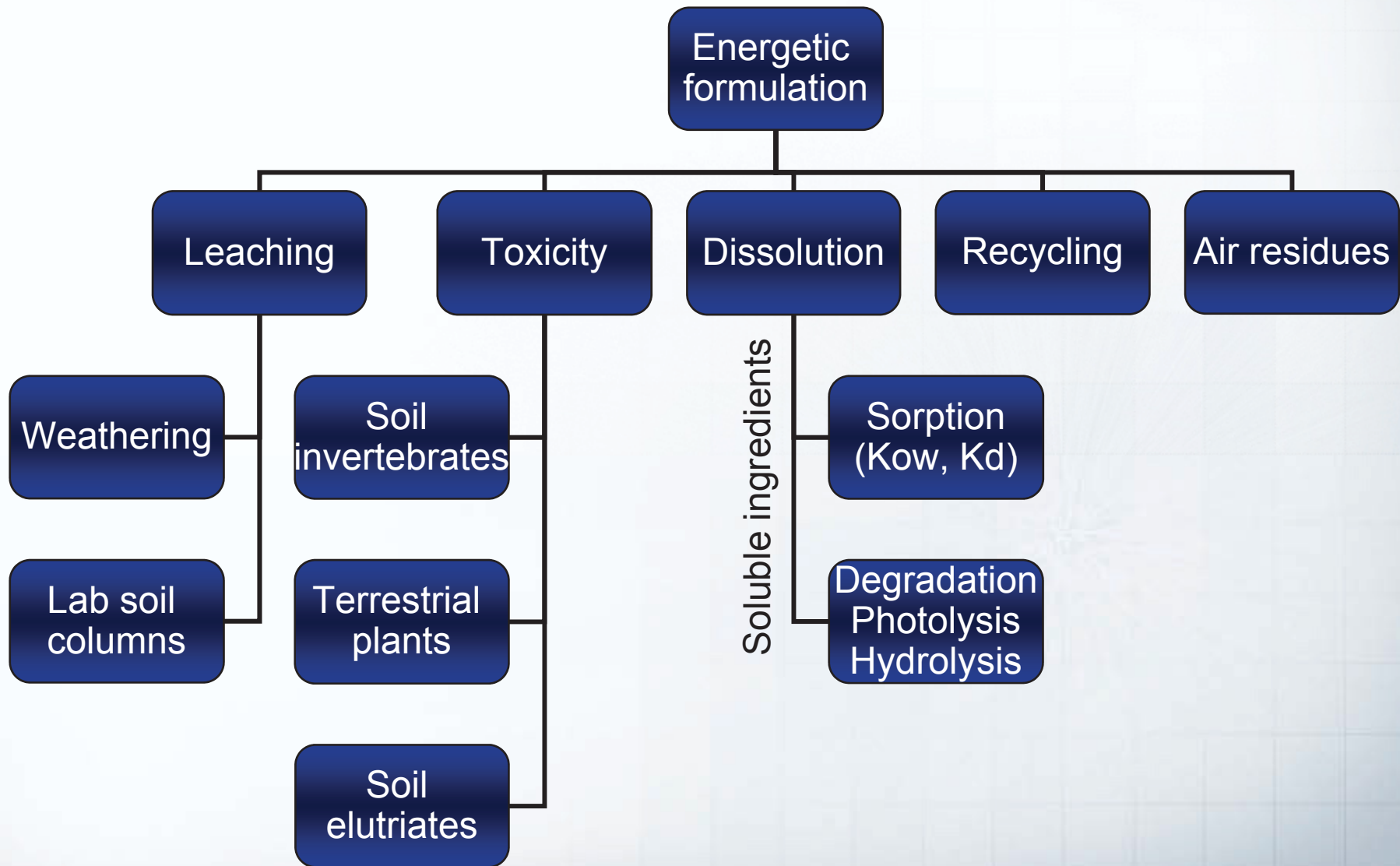

Environment - Propellant (WBS 4.2)

- **Air Residues (CRIQ)**

- ✓ Test method for air residues ready
- ✓ Reference formulation (M1 gun propellant) tested in Nicolet in Oct 09
- ✓ Formulations tested in closed vessel
 - ✓ Toxicity: TB < HELOVA < green M1
- Tests on LOVA in closed vessel to come
- Chosen formulation will be tested in 2012
- Results will be compared with closed vessels trials

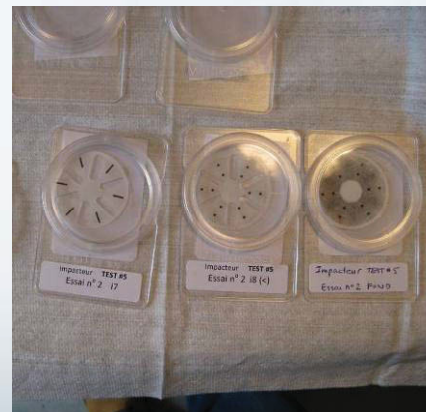

Emission gases

- Combustion gases: CO, CO₂, CH₄, NH₃, SO₂
- VOC (Methods TO-15 (Tedlar bags) and TO-17 (Carbotrap)):
 - > 100 compounds, mainly aromatics
 - Monocyclic aromatics: 80% (benzene)
 - Monocyclic aromatics, nitrogeneous : 10% (benzonitrile)
 - Aliphatic, nitrogeneous: 10%
 - Major compounds:
 - Benzene (300 to 350 ppb)
 - Toluene (150 to 200 ppb)
 - Carbonyle sulfide (40-120 ppb)
 - Methyl isocyanade (70-90 ppb)
 - Ethane dinitrile (10-75 ppb)

Emission gases

- SVOC:
 - Bicyclic aromatics: < 5% (main: naphtalene)
 - Monocyclic aromatics, nitrated: <1%
 - Phtalates (< 0.1%)
 - Polycyclic aromatics : < 0.1%
- Particulate matter
 - 160-210 mg/m³
 - Mean particle size 0.93 µm
 - Mainly Pb, K, S, Fe and Cu
 - Hg and H₂S at ppm level

Environment - Recycling (WBS 4.3)

1. Recovery of formulations from the munition

- ✓ Straightforward for propellants and GIM
- ✓ PBX: Pilot scale tests with high pressure water jets done
- Report in final revision since December 2010

2. Separation of components from the formulation

- Only remaining test is to extract the components from the slurry obtained from PBX recovery

	Formulation		Individual components			
	Name	Potential use	Recoverable	Percentage of formulation	Ease of recovery	Potential use
Explosives	GIM	Reuse or recycle	HMX, TNT, ETPE	100	High	Reuse or recycle
	CX-85	None	HMX	84	Low	Recycle
Propellants	TB	Recycle	NQ, NC	75	High	Reuse (NQ) or recycle (NC)
	MM1	Recycle	NC	92	High	Recycle
	HELOVA	Recycle	HMX, NC	92	High	Reuse (HMX) or recycle (NC)

- LOVA: HMX is expected to be extracted as easily as for HELOVA

Reuse: the alternative use of a munition or its components, for example change from operational to training use

Recycle: the use in a different item of materials recovered from a munition, e.g. mining or fertilizer industry

Environment Propellant Leaching (WBS 4.1.2)

- Indoor adsorption tests on sand column (20 x 3.7 cm)
- Outdoor dissolution test on fritted disk
- Results:
 - TEGDN leaching rate: **MM1 < TB < HELOVA**
 - Weight of TEGDN: **HELOVA < MM1 < TB**
 - The amount of TEGDN released from the Triple base is 4x higher than HELOVA's.
- Tests on LOVA are planned

Mass of TEGDN lixiviated from the gun propellant formulations during laboratory dissolution tests, column tests and weathering					
Experiment	SB	TB		HELOVA	
		2:1	1:2	Uncoated	Coated
Dissolution (mg/L)	1900	2008	3988	1091	962
Column tests ¹ (mg)	NA	2050	2820	NA	590
Weathering, grains ² (mg)	787	747	1422	236	210
Weathering, grinded ² (mg)	1288	1355	1131	459	343
Ratio of TEGDN lixiviated from the gun propellant formulations during laboratory dissolution tests, column tests and weathering					
	SB	TB		HELOVA	
		2:1	1:2	Uncoated	Coated
Column tests ¹ (%)	NA	65	87	NA	66
Weathering, grains ² (%)	26	31	60	35	31
Weathering, grinded ² (%)	43	57	50	66	49
¹ 1.5 simulated years		² 265 days			



TEGDN / propellant grains

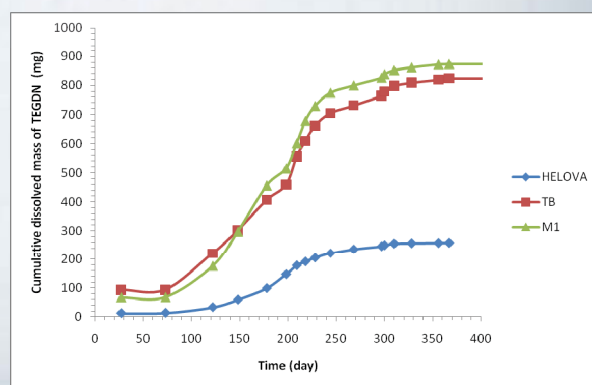
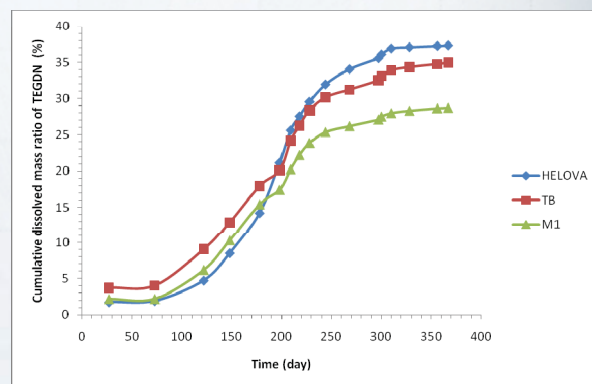

Ecotoxicological Study NRC-BRI Propellant Formulations (WBS 4.1.1)

✓ Dissolution: **TB > MM1 > HELOVA**

✓ Ecotoxicity: **MM1 > TB > HELOVA**

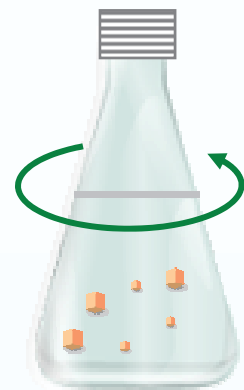

✓ Propellant formulations have adverse toxic effects on earthworm survival, earthworm avoidance behavior and ryegrass growth

✓ TEGDN may be the cause of toxicity in HELOVA and the other propellant formulations (TB and MM1)



- Based on data gathered thus far on formulations, **HELOVA seems to be the most stable formulation in terms of leakage and the less toxic formulation**

Ecotoxicological Study NRC-BRI

Individual Components of propellant formulations

(WBS 4.1.1)

Components of interest

HELOVA: HMX (68%), TEGDN (7%)

TB: NQ (24%), TEGDN (24%)

MM1: TEGDN (30%), AK (1%)

Sorption

- **HMX ~ AK > TEGDN > NQ**
(sand/silt/clay)
- No sorption in sand

Degradation

- Hydrolysis of HMX, TEGDN and AK was insignificant
- Degradation was insignificant in non sterile sand
- Slow degradation of TEGDN in sand/silt/clay
- Photolysis was the fastest degradation process and kinetics followed the order: **NQ > HMX > TEGDN > AK**
- Photolysis of solid formulations and identification of photoproducts is ongoing

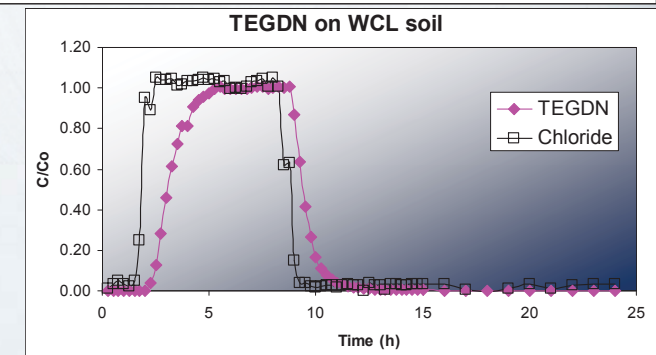
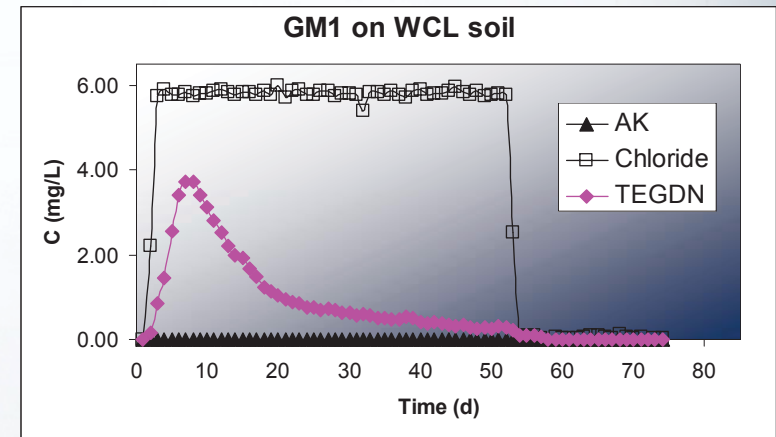

Life Cycle Costing (WBS 2)

POC : A. Sokri (CORA)



Cost-Efficiency Analysis (CEA)

Aim of Study

- The study uses a CEA to estimate the green munitions' incremental economic costs

Methodology

- Based on cost differences between green and conventional munitions

Relevant cost categories

Simulated data were used for:

- Liability
- Remediation
- Conception
- Manufacturing cost of each unit (shell, propelling charge, fuze, etc.)
- Demilitarization (e.g. Disposal)
- Initial investment (e.g., PBX plant)

Degree of completion

- Proceedings produced using a hypothetical military installation
- Still gathering data for production costs and munitions consumption
- Report will be completed in 2011 for a Canadian installation

Future Work

- The retrofit costs and the new build costs of the self-destruct fuze
- The end-to-end (i.e. Whole Life Cost) data for this capability
- The same analysis may be done for the Propellant and Explosive Green/IM, once possible, in order to identify the cost drivers per unit cost to bring this capability into service.

Insensitive Munitions – Small-Scale Testing

(WBS 5.2.2.7 and 5.4.3)

Composition	Bullet Impact	Shaped Charge Jet	Sympathetic Detonation	Slow Cook-off
Comp B	I or II	I	III	NA
GIM	V	I	III	NA
PBX	V	I	NR	NA
M1	IV	II	NA	IV-V
MM1	V	II	NA	IV-V
TB	V	II	NA	IV-V
HELOVA	V	II	NA	IV-V

NR: No reaction
 NA: Not available

- **Preliminary Variable Confinement Cook-Off**
 - Best results for PBX
- **Hot Fragment Conductive Ignition (for propellant)**
 - Best results for HELOVA
- **Fragment Impact**
 - Fragment launcher under development
 - Launcher was used to launch 10-g projectile over 6 km/s
 - Need to adapt launcher for 18.6-g projectile and 2.5 km/s



IM Sub-Scale Testing : Reaction to blow-in-place with C4 (WBS 5.2.2.7)

- As the main charge explosives (GIM and CX-85) have IM properties, their reaction to blow-in-place procedure has to be studied.
- Simulation of a UXO detonation with C4.
- Unburned residues were sampled and analyzed.
- Conclusion : all IM explosives lead to a high-order detonation, with traces of unburned explosives spread.



Selection Criteria

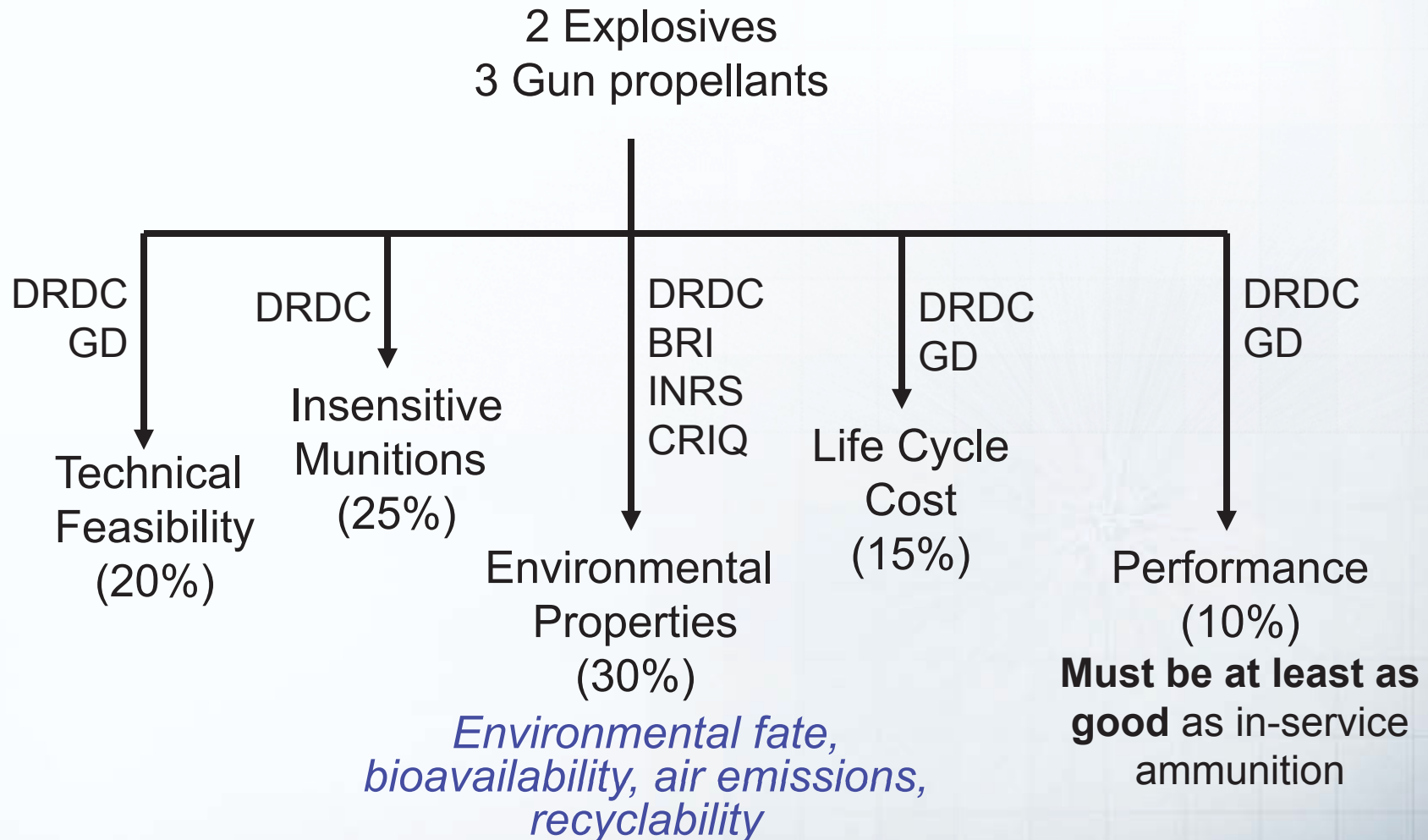

Conclusions

- RIGHTTRAC aims to demonstrate a greener and less vulnerable 105-mm round that will ease the environmental pressure on the Canadian Forces RTAs
- We are working on:
 - The fuze (to reach a near-zero dud rate)
 - The gun propellant (to incorporate less toxic ingredients that will also increase IM)
 - The explosive (to replace RDX – move to HMX, and add a binder that will reduce the bioavailability and increase IM)
- Each main deliverable can be used alone or with another one
- Each main deliverable can be used in another calibre.
- Life-cycle cost of current ammo vs green ammo
- International collaboration welcome

KTA 4-42: Development of a framework to assess the environmental impacts of green munitions constituents and of new energetic formulations



Objectives

- Framework to evaluate the environmental and health impacts of munitions constituents and formulations.
- User community: site managers, environmental professionals, munitions developers
- Will help perform appropriate risks assessments necessary to ensure the use of military RTAs as sustainable resources.
- Participants:
 - AU (DSTO)
 - UK (DSTL)
 - CA (DRDC, BRI, INRS)
 - US (USAPHC, ECBC)

Definition of green munitions

- No official definition of green munition in TTCP countries
- No such thing as a green munition!
- Greener munitions:
 - *Munitions that are designed to minimize their adverse environmental and occupational health impacts over their whole life cycle, while still retaining the necessary functionality and characteristics associated with their intended purpose*
- International collaboration welcome

RIGHTRAC

Revolutionary Inensitive, Green and Healthier Training Technology with Reduced Adverse Contamination
 Technologie d'entraînement révolutionnaire à vulnérabilité réduite, plus écologique et saine, réduisant la contamination nocive

Brochu, S., Brassard, M., Beauchemin, M., Eng, J. (DAEME), Oht, P., Anplerman, G., Brousseau, P., Coie, F., Diaz, E., Lussier, L.-S., Tanguay, V., Thibault, S.

Objective/Objectif:

- Decrease environmental contamination
- Decrease health hazards
- Improve munitions performance
- Réduire la contamination environnementale
- Réduire les risques pour la santé
- Améliorer les performances de la munition

More reliable fuzing system with self-destruct mechanism
 Decrease of dud rate

*Fusée plus fiable avec mécanisme d'auto-destruction
 Réduction du taux de raté*

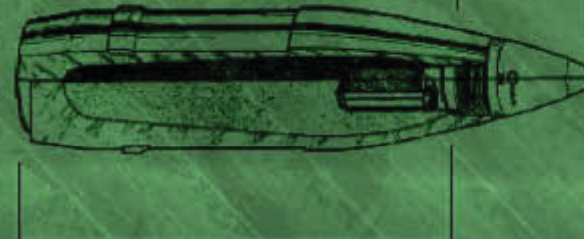

Green insensitive gun propellant

Poudre propulsive écologique à vulnérabilité réduite



Green insensitive explosive

Explosif écologique à vulnérabilité réduite

DEFENCE



DÉFENSE