



Government
of Canada

Gouvernement
du Canada

Canadian General
Standards Board

Office des normes
générales du Canada

Series 98
Série des 98

WITHDRAWAL

October 2017

Standards in series National Flag of Canada

These National Standards of Canada are hereby withdrawn as information contained therein may no longer represent the most current, reliable, and/or available information on these subjects. This withdrawal notice removes all remaining standards in the series.

The Standards Council of Canada requires that accredited Standards Development Organizations, such as the CGSB, regularly review a consensus Standard to determine whether to re-approve, revise or withdraw. The review cycle is normally five years from the publication date of the latest edition of the Standard. CGSB retains the right to develop new editions.

The information contained in these Standards was originally developed pursuant to a voluntary standards development initiative of the CGSB. The information contained therein may no longer represent the most current, reliable, and/or available information on these subjects. CGSB hereby disclaims any and all claims, representation or warranty of scientific validity, or technical accuracy implied or expressed respecting the information therein contained. The CGSB shall not take responsibility nor be held liable for any errors, omissions,

RETRAIT

Octobre 2017

Normes de la série Drapeau national du Canada

Ces Normes nationales du Canada sont retirées par le présent avis car l'information contenue peut ne plus représenter l'information disponible et/ou l'information la plus actuelle ou la plus fiable à ce sujet. Cet avis de retrait supprime toutes les normes restantes de la présente série.

Le Conseil canadien des normes exige que les organismes accrédités d'élaboration de normes, tel que l'ONGC, effectue régulièrement un examen des normes consensuelles afin de déterminer s'il y a lieu d'en renouveler l'approbation, de les réviser ou de les retirer. Le cycle d'examen d'une norme est généralement de cinq ans à partir de la date de publication de la dernière édition de celle-ci. L'ONGC se réserve le droit d'élaborer de nouvelles éditions.

L'information contenue dans ces normes a été élaborée initialement en vertu d'une initiative volontaire d'élaboration de normes de l'ONGC. Elle peut ne plus représenter l'information disponible et/ou l'information la plus actuelle ou la plus fiable à ce sujet. L'ONGC décline par la présente toute responsabilité à l'égard de toute affirmation, déclaration ou garantie de validité scientifique ou d'exactitude technique implicite ou explicite relative à l'information contenue dans ces normes. L'ONGC n'assumera aucune responsabilité et ne sera pas tenu responsable quant à toute

inaccuracies or any other liabilities that may arise from the provision or subsequent use of such information.

Copies of withdrawn standards are available from the CGSB Sales Centre by telephone at 819-956-0425 or 1-800-665-2472, by fax at 819-956-5740, by Internet at www.tpsgc-pwgsc.gc.ca/ongc-cgsb/index-eng.html, by e-mail at ncr.CGSB-ONGC@tpsgc-pwgsc.gc.ca or by mail at Sales Centre, Canadian General Standards Board, 11 Laurier Street, Gatineau, Canada K1A 1G6.

CAN/CGSB-98.1-2011

National Flag of Canada
(Outdoor use) (ICS 99.020.10)

CAN/CGSB-98.2-2011

National Flag of Canada
(Indoor use) (ICS 99.020.10)

CAN/CGSB-98.3-M91

National Flag of Canada
(One-event-only use) (ICS 03.160)

erreur, omission, inexactitude ou autre conséquence pouvant découler de la fourniture ou de l'utilisation subséquente de cette information.

Des copies des normes retirées peuvent être obtenues auprès du Centre des ventes de l'ONGC. Il suffit d'en faire la demande par téléphone au 819-956-0425 ou 1-800-665-2472, par télécopieur au 819-956-5740, par Internet à : www.tpsgc-pwgsc.gc.ca/ongc-cgsb/index-fra.html, par courriel à ncr.CGSB-ONGC@tpsgc-pwgsc.gc.ca, ou par courrier adressé au Centre des ventes, Office des normes générales du Canada, 11, rue Laurier, Gatineau, Canada K1A 1G6.

CAN/CGSB-98.1-2011

Drapeau national du Canada
(pour utilisation à l'extérieur) (ICS 99.020.10)

CAN/CGSB-98.2-2011

Drapeau national du Canada
(pour utilisation à l'intérieur) (ICS 99.020.10)

CAN/CGSB-98.3-M91

Drapeau national du Canada
(pour une seule occasion) (ICS 03.160)



Government
of Canada

Gouvernement
du Canada

Canadian General
Standards Board

Office des normes
générales du Canada

CAN/CGSB-98.2-2011

Supersedes CAN/CGSB-98.2-92

National Flag of Canada (Indoor use)

ICS 99.020.10



Standards Council of Canada
Conseil canadien des normes

National Standard of Canada

Canada 

Experience and excellence 
Expérience et excellence 

The CANADIAN GENERAL STANDARDS BOARD (CGSB), under whose auspices this National Standard of Canada has been developed is a government agency within Public Works and Government Services Canada. CGSB is engaged in the production of voluntary standards in a wide range of subject areas through the media of standards committees and the consensus process. The standards committees are composed of representatives of relevant interests including producers, consumers and other users, retailers, governments, educational institutions, technical, professional and trade societies, and research and testing organizations. Any given standard is developed on the consensus of views expressed by such representatives.

CGSB has been accredited by the Standards Council of Canada as a national standards-development organization. The standards that it develops and offers as National Standards of Canada conform to the criteria and procedures established for this purpose by the Standards Council of Canada. In addition to standards it publishes as national standards, CGSB produces standards to meet particular needs, in response to requests from a variety of sources in both the public and private sectors. Both CGSB standards and CGSB national standards are developed in conformance with the policies described in the CGSB Policy Manual for the Development and Review of Standards.

CGSB standards are subject to review and revision to ensure that they keep abreast of technological progress. Suggestions for their improvement, which are always welcome, should be brought to the notice of the standards committees concerned. Changes to standards are issued either as separate amendment sheets or in new editions of standards.

An up-to-date listing of CGSB standards, including details on latest issues and amendments, and ordering instructions, is found in the CGSB Catalogue, which is published annually and is available without charge upon request. More information is available about CGSB products and services at our Web site — www.ongc-cgsb.gc.ca.

Although the intended primary application of this standard is stated in its Scope, it is important to note that it remains the responsibility of the users of the standard to judge its suitability for their particular purpose.

The testing and evaluation of a product against this standard may require the use of materials and/or equipment that could be hazardous. This document does not purport to address all the safety aspects associated with its use. Anyone using this standard has the responsibility to consult the appropriate authorities and to establish appropriate health and safety practices in conjunction with any applicable regulatory requirements prior to its use. CGSB neither assumes nor accepts any responsibility for any injury or damage that may occur during or as the result of tests, wherever performed.

Attention is drawn to the possibility that some of the elements of this Canadian standard may be the subject of patent rights. CGSB shall not be held responsible for identifying any or all such patent rights. Users of this standard are expressly advised that determination of the validity of any such patent rights is entirely their own responsibility.

Further information on CGSB and its services and standards may be obtained from:

The Manager
Standards Division
Canadian General Standards Board
Gatineau, Canada
K1A 1G6

The STANDARDS COUNCIL OF CANADA is the coordinating body of the National Standards System, a coalition of independent, autonomous organizations working towards the further development and improvement of voluntary standardization in the national interest.

The principal objects of the SCC are to foster and promote voluntary standardization as a means of advancing the national economy, benefiting the health, safety and welfare of the public, assisting and protecting the consumer, facilitating domestic and international trade, and furthering international cooperation in the field of standards.

A National Standard of Canada (NSC) is a standard prepared or reviewed by an accredited Standards Development Organization (SDO) and approved by the SCC according to the requirements of CAN-P-2. Approval does not refer to the technical content of the standard; this remains the continuing responsibility of the SDO. A NSC reflects a consensus of a number of capable individuals whose collective interests provide, to the greatest practicable extent, a balance of representation of general interests, producers, regulators, users (including consumers), and others with relevant interests, as may be appropriate to the subject in hand. It normally is a standard, which is capable of making a significant and timely contribution to the national interest.

Those who have a need to apply standards are encouraged to use NSCs. These standards are subject to periodic review. Users of NSCs are cautioned to obtain the latest edition from the SDO, which publishes the standard.

The responsibility for approving standards as National Standards of Canada rests with the:

Standards Council of Canada
200-270 Albert Street
Ottawa, Ontario
K1P 6N7

How to order **CGSB** Publications:

by telephone — 819-956-0425 *or*
— 1-800-665-2472

by fax — 819-956-5740

by mail — CGSB Sales Centre
Gatineau, Canada
K1A 1G6

in person — Place du Portage
Phase III, 6B1
11 Laurier Street
Gatineau, Quebec

by email — ncr.cgsb-ongc@pwgsc.gc.ca

on the Web — www.ongc-cgsb.gc.ca

**National Flag of Canada
(Indoor use)**

CETTE NORME NATIONALE DU CANADA EST DISPONIBLE EN VERSIONS
FRANÇAISE ET ANGLAISE.

Prepared by the
Canadian General Standards Board 

Approved by the
Standards Council of Canada 

**Published April 2011 by the
Canadian General Standards Board
Gatineau, Canada K1A 1G6**

© HER MAJESTY THE QUEEN IN RIGHT OF CANADA,
as represented by the Minister of Public Works and Government Services,
the Minister responsible for the Canadian General Standards Board (2011).

No part of this publication may be reproduced in any form without the prior permission of the publisher.

CANADIAN GENERAL STANDARDS BOARD
Committee on the National Flag of Canada

(Voting membership at date of approval)

Chair

Bauerle, J.¹ Bodycote Materials Testing Canada Inc.

General Interest Category

Batcheller, J. University of Alberta
Davie, N. Consultant
Gagnon, M. Canadian Heritage/Contracting and Materiel Management
Horne, L. University of Manitoba
Izquierdo, V. Textile Technologies Centre
Zhao, J. National Defence/QETE
Zwinkels, J. National Research Council of Canada

Producer Category

Arsenault, C. Drapeaux et Bannières L'Étendard Inc.
Braverman, S. International Flag & Banner Inc.
Dawood, A. Scythes Inc.
Geurtsen, O. Tri-Tex Co. Inc.
Law, I. Flags Unlimited
Sloane, R. Flag Connection Inc.
Stavinga, B. Invista (Canada) Co.
White, R. Textile Artcraft

User Category

Bacon, R. Canadian Heritage/State Ceremonial and Corporate Events
Fauvelle, C. National Capital Commission
Carrick, D. National Defence/DSSPM
MacLeod, J. Public Works and Government Services Canada/
Clothing & Textile Division
Paquette, R. Public Works and Government Services Canada/
Contracting & Procurement
Wardroper, A. Royal Canadian Mounted Police

Secretary (non-voting)

Grabowski, M. Canadian General Standards Board

Acknowledgment is made for the translation of this National Standard of Canada by the Translation Bureau of Public Works and Government Services Canada.

¹ General interest

Contents	Page
1 Scope.....	1
2 Normative references	1
3 Classification	2
3.1 Types	2
3.2 Classes	3
3.3 Sizes	3
4 General requirements	3
5 Detailed requirements	3
5.1 Design.....	3
5.2 Colours	3
5.3 Colourfastness	4
5.4 Length (L) and width (W)	5
5.5 Materials.....	5
5.5.1 Flag	5
5.5.2 Header	5
5.5.3 Sewing thread.....	6
5.5.4 Tie tapes (Type 2 only)	6
5.5.5 Leather tabs (Type 3 only)	6
5.5.6 Ornamental fringe, cord and tassels (Class A only)	6
5.6 Construction	6
5.6.1 General	6
5.6.2 Printed flags.....	6
5.6.3 Appliquéd flags.....	6
5.6.4 Seams and stitching.....	6
6 Preparation for delivery	7
6.1 Packaging and packing.....	7
6.2 Labelling.....	7
7 Inspection	7
7.1 Sampling	7
8 Notes.....	8
8.1 Options	8
8.2 Related publications	8

National Flag of Canada (Indoor use)

1 Scope

This standard applies to the design, colour, materials, construction and performance requirements of the National Flag of Canada intended for indoor use.

The testing and evaluation of a product against this standard may require the use of materials and equipment that could be hazardous. This standard does not purport to address all the safety aspects associated with its use. Anyone using this standard has the responsibility to consult the appropriate authorities and to establish appropriate health and safety practices in conjunction with any applicable regulatory requirements prior to its use. CGSB neither assumes nor accepts any responsibility for any injury or damage that may occur during or as the result of tests, wherever performed.

2 Normative references

The following normative documents contain provisions that, through reference in this text, constitute provisions of this National Standard of Canada. The referenced documents may be obtained from the sources noted below.

An undated reference is to the latest edition or revision of the reference or document in question, unless otherwise specified by the authority applying this standard. A dated reference is to the specified revision or edition of the reference or document in question. However, parties to agreements based on this National Standard of Canada are encouraged to investigate the possibility of applying the most recent editions of the normative documents indicated below.

2.1 Canadian General Standards Board

CAN/CGSB-4.2 — *Textile Test Methods:*

No. 4.1 — *Textiles — Fabrics — Determination of Width and Length*

No. 5.1 — *Unit Mass of Fabrics*

No. 18.3/ISO 105-B02 — *Textiles — Tests for Colourfastness — Part B02: Colourfastness to Artificial light: Xenon Arc Fading Lamp Test*

No. 19.1 — *Colourfastness to Washing — Accelerated Tests — Launder-Ometer*

No. 22 — *Colourfastness to Rubbing (Crocking)*

No. 25.1 — *Dimensional Change in Wetting*

No. 27.1 — *Flame Resistance — Vertical Burning Test*

No. 29.1 — *Colourfastness to Dry Cleaning Solvent*

4-GP-85 — *Nylon Thread (Continuous Multifilament)*

4-GP-97 — *Polyester Thread (Continuous Multifilament)*

CAN/CGSB-86.1 — *Care Labelling of Textiles*

CAN/CGSB-54.1 Part 1/ISO 4915 — *Stitches and Seams — Part 1: Textiles — Stitch Types — Classification and Terminology.*

2.1.1 Source

The above may be obtained from the Canadian General Standards Board, Sales Centre, Gatineau, Canada K1A 1G6. Telephone 819-956-0425 or 1-800-665-2472. Fax 819-956-5740. E-mail ncr.cgsb-ongc@tpsgc-pwgsc.gc.ca. Web site www.ongc-cgsb.gc.ca.

2.2 American Society for Testing and Materials (ASTM)

D1388-1996 (2002) — *Standard Test Method for Stiffness of Fabrics*

E308 — *Standard Practice for Computing the Colors of Objects by Using the CIE System.*

2.2.1 Source

The above may be obtained from ASTM International, 100 Barr Harbor Drive, West Conshohocken, PA 19428-2959, U.S.A., telephone 610-832-9585, fax 610-832-9555, or from IHS Canada, 1 Antares Drive, Suite 200, Ottawa, Ontario K2E 8C4, telephone 613-237-4250 or 1-800-387-4408, fax 613-237-4251, Web site www.global.ihs.com.

2.3 International Commission on Illumination (CIE)

CIE S 014-1/E2006 / ISO 11664-1 *Colorimetry — Part 1 : CIE Standard Colorimetric Observers*

CIE S 014-2/E2006 / ISO 11664-2 *Colorimetry — Part 2 : CIE Standard Illuminants.*

2.3.1 Source

The above may be obtained from the CIE Central Bureau, Kegelgasse 27, A-1030 Vienna, Austria. Telephone +43 1 71432870. Fax +43 1 714318718. Web site www.cie.co.at.

3 Classification

The flag shall be supplied in the following types, classes and sizes as specified (clause 8.1).

3.1 Types

Type	Subtype	In accordance with figures
1- Header with open-sleeve	1A Integral header	6 and 9 (Sections A-A, B-B, D-D)
	1B Separate header	6 and 11 (Sections A-A, B-B, D-D)
2- Header with open-sleeve and tie tapes	2A Integral header	7 and 9 (Sections A-A, B-B, C-C, E-E)
	2B Separate header	7 and 11 (Sections A-A, B-B, C-C, E-E)
3- Header with open-sleeve and leather tabs	3A Integral header	8, 9 (Sections A-A, B-B), and 10 (Section F-F)
	3B Separate header	8, 11 (Sections A-A, B-B), and 12 (Section F-F)

3.2 Classes

Class A — With ornamental fringe, cord and tassels

Class B — Without ornamental fringe, cord and tassels.

3.3 Sizes

Size 1 — 12 x 24 cm

Size 2 — 15 x 30 cm

Size 3 — 20 x 40 cm

Size 4 — 30 x 60 cm

Size 5 — 45 x 90 cm

Size 6 — 65 x 130 cm

Size 7 — 82 x 164 cm

Size 8 — 90 x 180 cm.

4 General requirements

The flag shall be free of defects in materials and workmanship that may affect its appearance or serviceability.

5 Detailed requirements

5.1 Design

The flag shall be of the proportions two by length and one by width, containing in its centre a white square the depth of the flag, with a single red maple leaf centred therein, in accordance with Figure 1.

5.2 Colours

The red and white colours shall have the following CIE (International Commission on Illumination) colour coordinates when measured in accordance with ASTM E308 using CIE Standard 1964 Illuminant D65 and the CIE 1964 Standard Colorimetric Observer with specular reflection excluded:

Table 1 — Colorimetric requirements

Red:	White:
$x = 0.576 \pm 0.028$	$x = 0.328 \pm 0.012$
$y = 0.315 \pm 0.012$	$y = 0.344 \pm 0.015$
$Y = 9.5 \pm 1.5$	$Y = 78.0 \pm 3.0$

5.3 Colourfastness

The colourfastness of the flag shall be in accordance with the requirements of Table 2.

Table 2 — Finished flag fabric requirements

Property	Requirement	Test Method CAN/CGSB-4.2 ^a
Weave	Plain, 1 x 1	—
Mass, g/m ² , min.	120	No. 5.1
Dimensional change in wetting, % limit		No. 25.1
— warp	2	
— weft	2	
Colourfastness, min.		
to light ^b	AATCC L5 or L7, Grey Scale 4	No. 18.3/ISO 105-B02 ^c
to washing ^d	Grey Scale 4	No. 19.1, Test No. 1
— colour change for red portion		
— staining for white portion		
to dry cleaning ^d	Grey Scale 4	No. 29.1
— colour change for red portion		
— staining for white		
to crocking, dry ^e	Grey Scale 5	No. 22
— colour change		
— staining		
Flammability (average for 5 samples)	Char length — 100 mm After flame — 2 s No burning drips or debris	No. 27.1
Flexural rigidity	No less than 200 mg/cm (Option A)	ASTM D1388-1996 (2002)

^a Unless otherwise indicated.

^b To be specified (clause 8.1).

^c Soda-lime/borosilicate system.

^d Sample must be ½ red and ½ white.

^e Repeat dry crocking test rubbing half-red and half-white each time. There shall be no observable streaking, smearing or staining onto the half-white rubbed parts.

5.4 Length (L) and width (W)

The flag shall be of the length and width specified (clause 3.3 and Tables 3 and 4) when measured in accordance with CAN/CGSB-4.2 No. 4.1.

Table 3 — National flag — dimensions

All dimensions are in centimetres.

Flag size ^a	Width X ^b	Length L ^b	Red Y ^b	White Z ^b
1	12 ± 0.3	24 ± 0.5	6.0 ± 0.2	12 ± 0.2
2	15 ± 0.3	30 ± 0.5	7.5 ± 0.2	15 ± 0.2
3	20 ± 0.3	40 ± 0.5	10.0 ± 0.2	20 ± 0.2
4	30 ± 0.5	60 ± 1.0	15.0 ± 0.3	30 ± 0.3
5	45 ± 0.5	90 ± 1.0	22.5 ± 0.3	45 ± 0.3
6	65 ± 1.0	130 ± 1.5	32.5 ± 0.5	65 ± 0.5
7	82 ± 1.0	164 ± 1.5	41.0 ± 0.5	82 ± 0.5
8	90 ± 1.0	180 ± 1.5	45.0 ± 0.5	90 ± 0.5

^a See clause 3.3.

^b See Figures 2, 3 and 4.

Table 4 — Header dimensions

All dimensions are in centimetres.

Flag size ^b	Header dimension W ^a cm ± 2%	
	Type 1, 2 ^c V ^d	Type 3 ^c V ^d
1-2	4.0	6.5
3-8	6.5	6.5

^a See Figures 2, 3 and 4. W = V in Figures 9 and 11 (Sections D-D and E-E).

^b See clause 3.3.

^c See clause 3.1.

^d See Figures 9 and 11 (Sections D-D and E-E).

5.5 Materials

5.5.1 Flag

The flag shall be made of woven fabric in accordance with Table 2.

5.5.2 Header

The header material shall be white fabric in accordance with Table 2.

5.5.3 Sewing thread

The flag shall be sewn with red and/or white thread in accordance with CGSB Standard 4-GP-85 or 4-GP-97, as specified (clause 8.1).

5.5.4 Tie tapes (Type 2 only)

There shall be two 16 x 400 mm woven or braided white tapes, with a mass of 3.50 ± 0.25 g/m when tested in accordance with CAN/CGSB-4.2 No. 5.1. The free length of the tie tape shall be approximately 18 cm.

5.5.5 Leather tabs (Type 3 only)

The leather tabs shall be black or brown leather with the shape and dimensions specified in Figure 8.

5.5.6 Ornamental fringe, cord and tassels (Class A only)

The ornamental fringe shall be gold, 5 to 7 cm wide. The ornamental cord shall be 3 ply, 6 mm diameter gold cord finished with a gold tassel 7 to 8 cm long at each end. The cord and tassels shall visually match the colour of the ornamental fringe.

5.6 Construction

5.6.1 General

The flag shall be dye-printed or appliquéd. Construction of the flag shall be in accordance with the following:

- a) One-piece flag — Figures 2 and 5 (Sections A-A and B-B)
- b) Three-piece flag — Figures 3 and 5 (Sections A-A, B-B and C-C)
- c) Four-piece flag — Figures 4 and 5 (Sections A-A, B-B and C-C).

5.6.2 Printed flags

The tolerance for bowing of the vertical red panel edges of printed flags are as follows:

- a) Size 1 (12 x 24 cm) through size 4 (30 x 60 cm): 6 mm
- b) Size 5 (45 x 90 cm) through size 8 (90 x 180 cm): 12 mm.

5.6.3 Appliquéd flags

For all appliquéd flags, the appliqué shall be applied to both sides of the flag.

For all flags printed in one piece, the length of the flag shall be parallel to the warp direction of the fabric. For flags of more than one piece, the length of the flag shall be parallel to the weft direction of the fabric.

5.6.4 Seams and stitching

All seams and stitchings shall be lockstitch or chain stitch (Type 301 or Type 401, respectively, in accordance with CAN/CGSB-54.1, Part 1/ISO 4915) with not less than 2.5 and not more than 3.6 stitches per centimeter. The ends of all stitchings and any breaks in the sewing thread during stitching shall be securely backstitched.

For Class A flags, the ornamental fringe shall be sewn to the top, bottom and fly edges of the flag in such a manner as not to pucker the flag fabric.

6 Preparation for delivery

6.1 Packaging and packing

Unless otherwise specified (clause 8.1), packaging and packing shall conform to normal commercial practice.

6.2 Labelling

The flag shall have affixed to the header, a label upon which at least the following information, in both English and French, is printed in a type height not less than 6 mm and not more than 12 mm:

Manufacturer's name and mailing address or CA number

"CANADA"

Size

Date of manufacture

Cleaning and drying instructions (in accordance with CAN/CGSB-86.1).

The label shall be legible and permanent to the conditions of use of the flag and shall have no detrimental effect on the flag.

7 Inspection

7.1 Sampling

Sampling for inspection and testing shall be left to the discretion of the inspection authority, unless a specific sampling plan is specified (clause 8.1).

8 Notes

8.1 Options

The following options must be specified in the application of this standard:

- a) Type, class and size of flag (clause 3)
- b) Colourfastness to light requirement (clause 5.3, Table 2)
- c) Colour and type of sewing thread (clause 5.5.3)
- d) Packaging and packing, if other than as specified (clause 6.1)
- e) Sampling, if a specific plan is specified (clause 7.1).

8.2 Related publications

8.2.1 Department of Canadian Heritage

Flag Etiquette in Canada, Catalogue Number CH4-1/5-2001,
<http://www.publications.gc.ca>.

8.2.2 Department of Justice Canada

National Flag of Canada Manufacturing Standards Act.
<http://laws.justice.gc.ca>.

WITHDRAWN

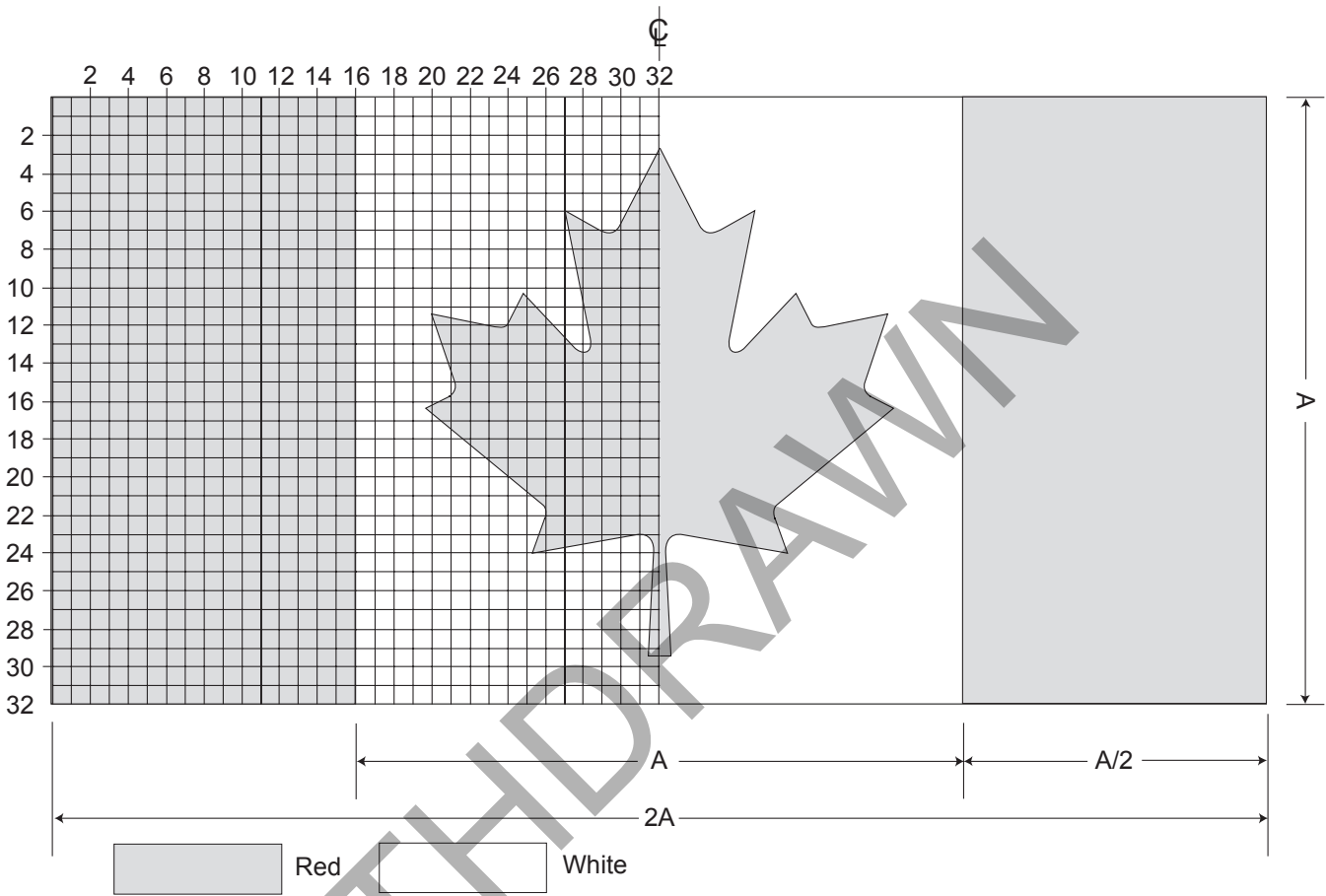

Figure 1 — Design of the National Flag of Canada

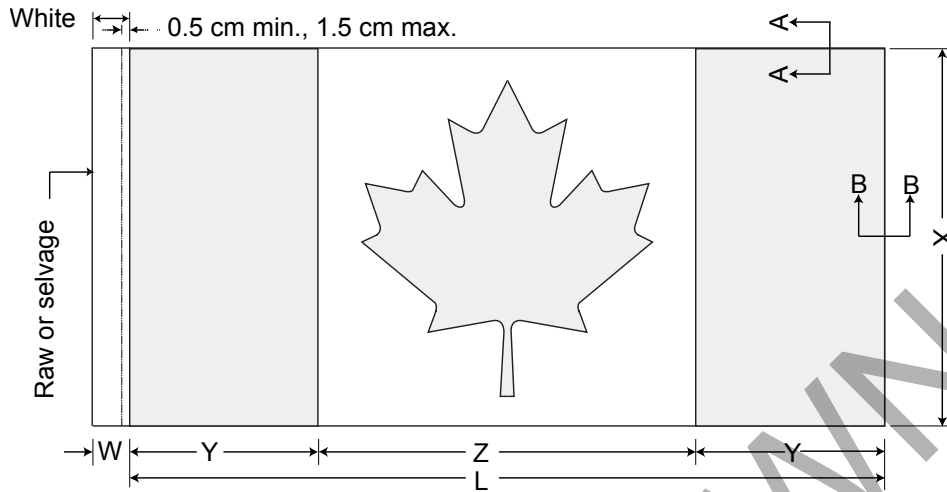

Figure 2 — One-piece flag construction

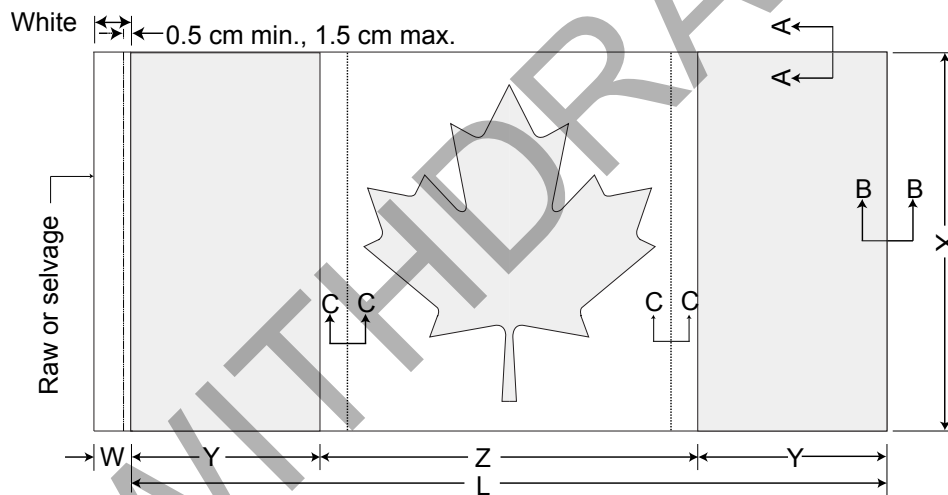

Figure 3 — Three-piece flag construction

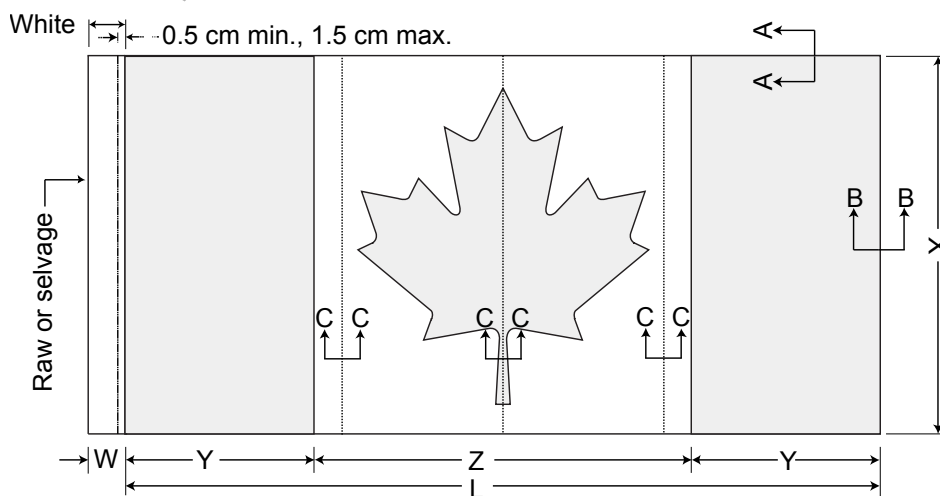

Figure 4 — Four-piece flag construction

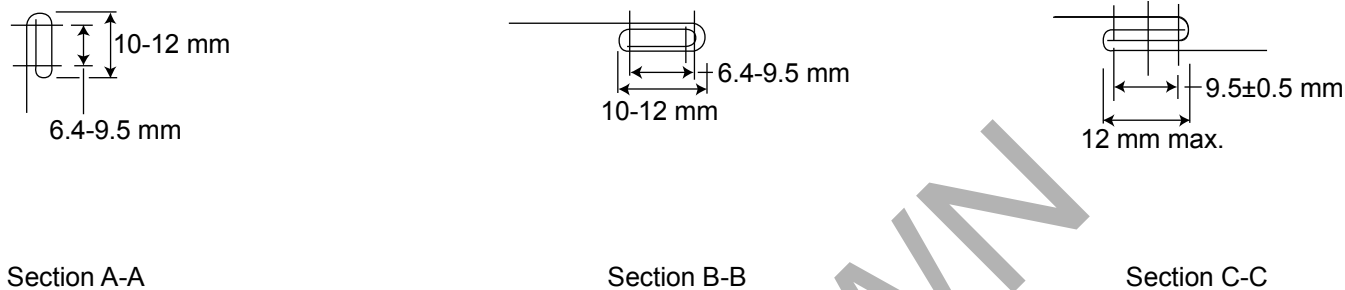

Figure 5 — Construction details

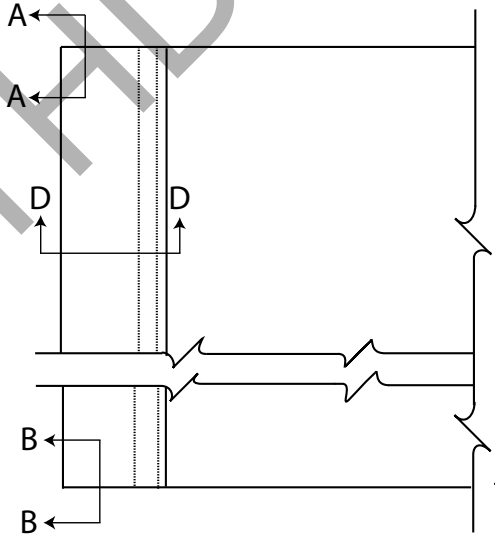
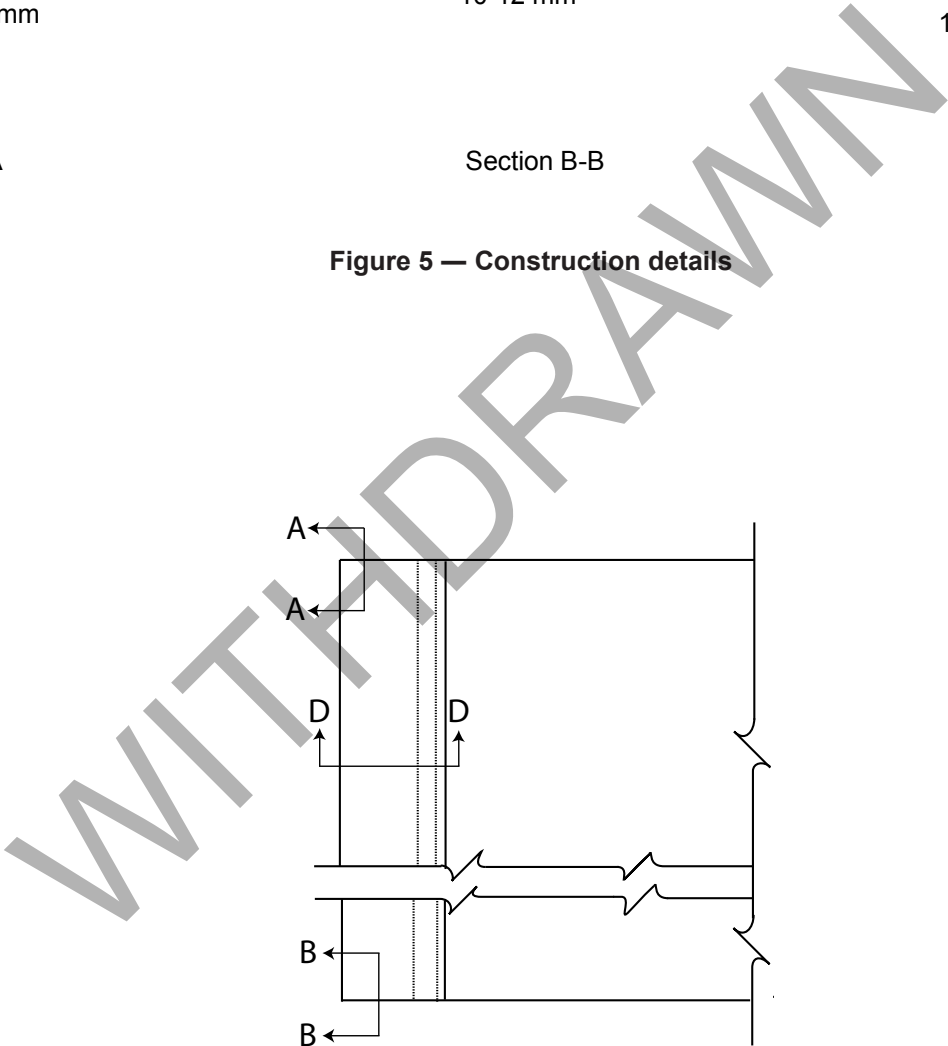

Figure 6 — Type 1 — Header, open-sleeve

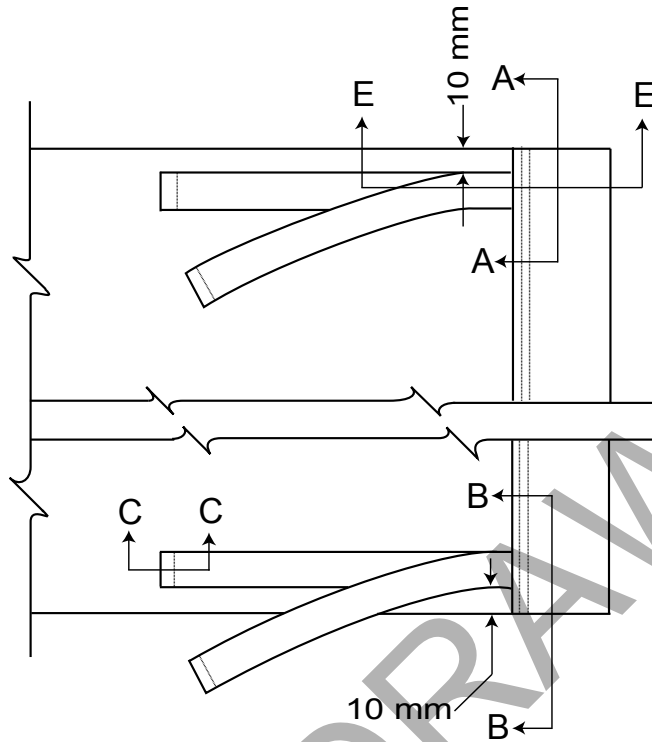

Figure 7 — Type 2 — Header, open-sleeve with tie tapes

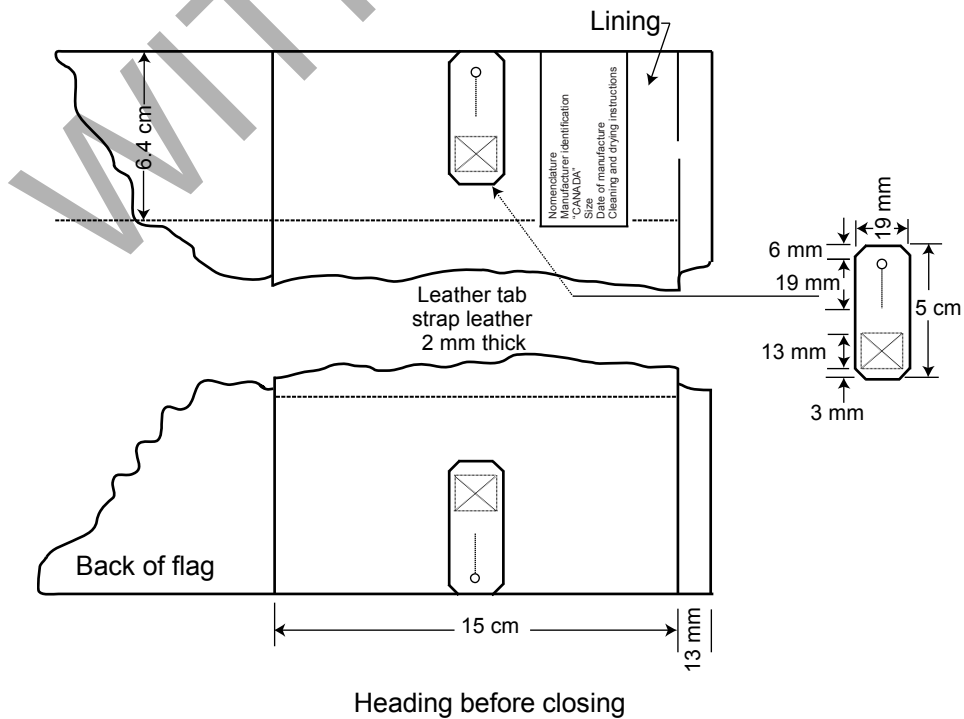
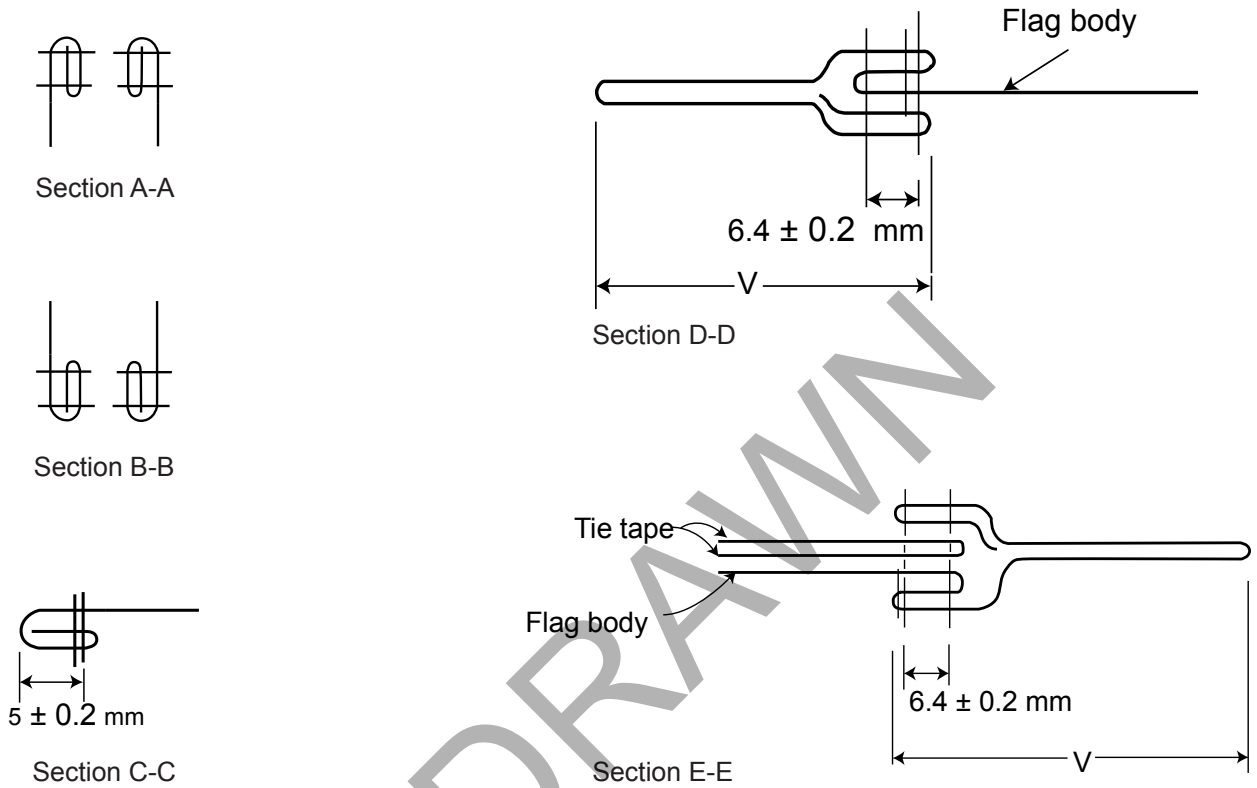

Figure 8 — Type 3 — Header, open-sleeve with leather tabs



Unless otherwise specified, dimensions are in centimetres.

Figure 9 — Construction details — Subtype 1A, 2A and 3A flags

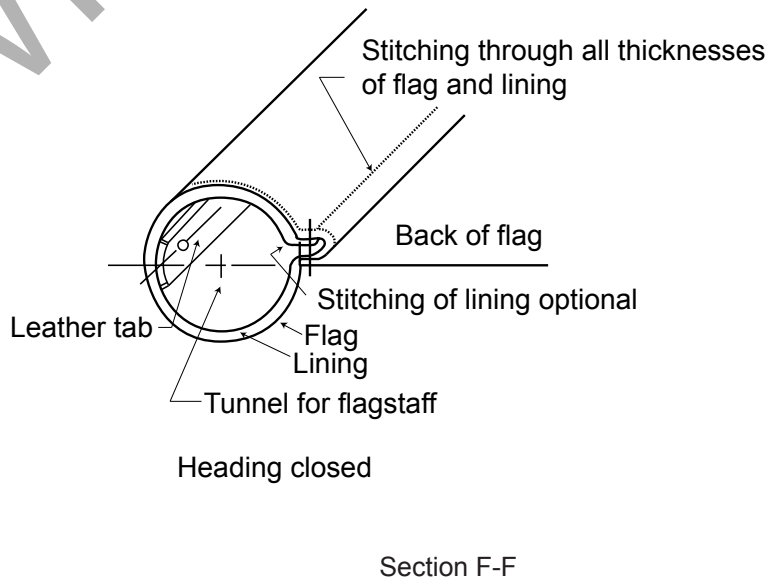
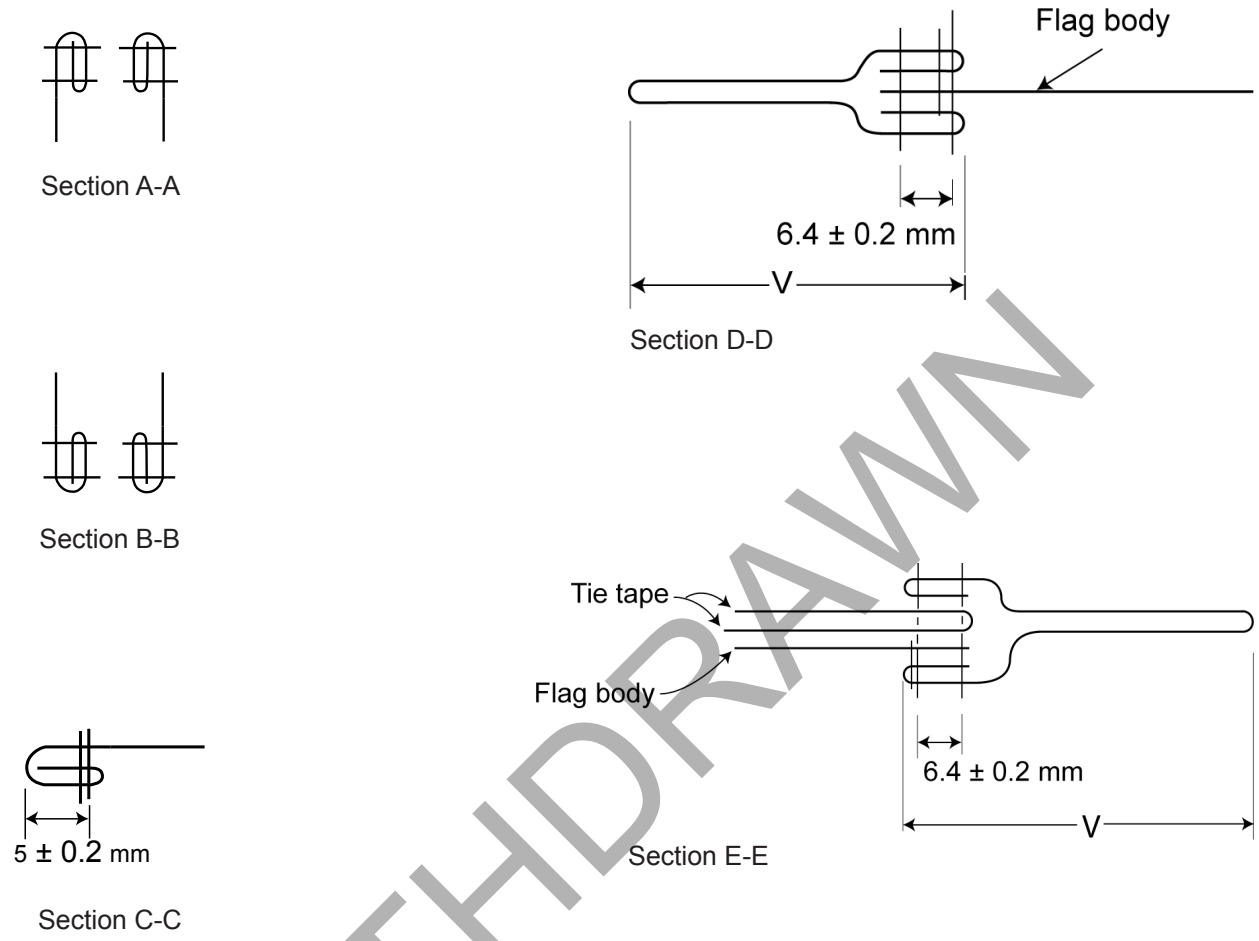

Figure 10 — Construction details for flag type — Subtype 3A flag



Unless otherwise specified, dimensions are in centimetres.

Figure 11 — Construction details — Subtype 1B, 2B and 3B flags

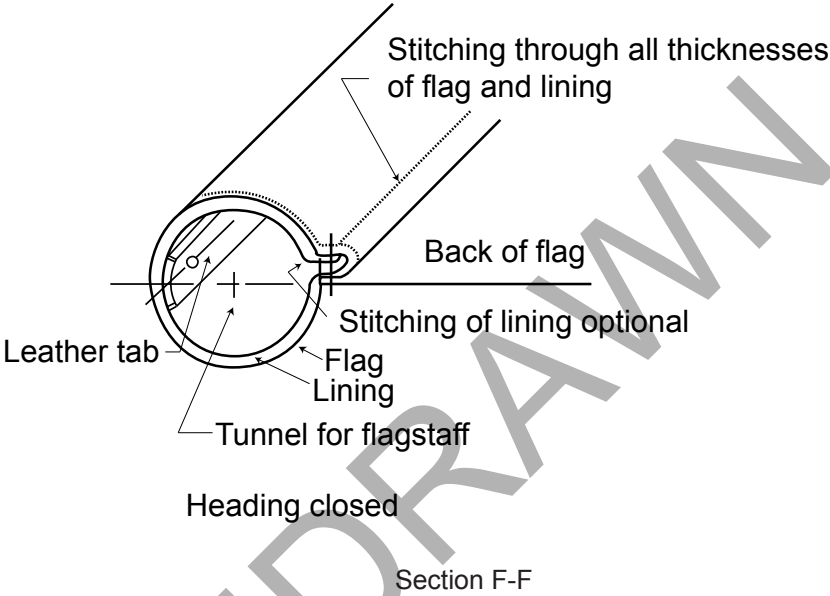

Figure 12 — Construction details for flag type — Subtype 3B flag