

**COMBUSTION VENTING**  
**STUDENT**  
**MANUAL/REFERENCE TEXT**

**JANUARY 1991**

**Prepared by:**  
**Geddes Enterprises**  
**Scanada Consultants Ltd.**  
**National Energy Conservation Association**  
**Energy Building Group**

**for**

**Canada Mortgage and Housing Corporation**

Canada Mortgage and Housing Corporation, the Federal Government's housing agency is responsible for administering the National Housing Act

This legislation is designed to aid in the improvement of housing and living in Canada. As a result, the Corporation has interests in all aspects of housing and urban growth and development.

Under Part IX of this act, the Government of Canada provides funds to CMHC to conduct research into social, economic and technical aspects of housing and related fields, and to undertake the publishing and distribution of the results of this research. CMHC therefore has the statutory responsibility to make widely available, information which may be useful in the improvement of housing and living conditions.

This publication is one of many items of information published by CMHC with the assistance of federal funds.

DISCLAIMER

This document was prepared by Geddes Enterprises for Canada Mortgage and Housing Corporation under Part IX of the National Housing Act. The analysis, interpretations and recommendations are those of the consultant and do not necessarily reflect the views of Canada Mortgage and Housing Corporation or those divisions of the corporation that assisted in the study and its publication.

# TABLE OF CONTENTS

	Page
<b>1. INTRODUCTION</b>	
1.1 PREFACE	1 - 1
1.2 BACKGROUND	1 - 2
1.3 EXPLANATION OF TERMS	1 - 3
<b>2. HOUSE AS A SYSTEM</b>	
2.1 THE CONCEPT	2 - 1
2.2 INTRODUCTION	2 - 2
2.3 AIR FLOW	2 - 2
2.4 STACK EFFECT	2 - 3
2.5 WIND EFFECT	2 - 5
2.6 DISTRIBUTION SYSTEM EFFECT	2 - 5
2.7 FLUE AND VENTILATION EFFECTS	2 - 5
2.9 COMBINED EFFECTS	2 - 8
<b>3. OVERVIEW OF COMBUSTION VENTING SYSTEM INSPECTION, ASSESSMENTS AND TESTS</b>	
3.1 INTRODUCTION	3 - 1
3.2 AN OVERVIEW OF "ACT"	3 - 3
3.3 VENTING SYSTEM TEST	3 - 4
3.4 CHIMNEY PERFORMANCE TEST	3 - 4
3.5 LEAKY HEAT EXCHANGERS	3 - 4
3.6 SUMMARY	3 - 5
<b>4. THE "ACT" DETAILED PROCEDURES</b>	
4.1 THE "ACT" ASSESSMENT	4 - 1
4.2 THE "ACT" CHECK	4 - 1
4.3 THE "ACT" TEST	4 - 5
<b>5. THE VENTING SYSTEM TEST</b>	
5.1 INTRODUCTION	5 - 1
5.2 GENERAL PRINCIPLES AND PROCEDURES	5 - 1
5.3 TOOLS AND TIME REQUIREMENTS	5 - 3
5.4 THE STEP-BY-STEP TEST	5 - 7
<b>6. THE CHIMNEY PERFORMANCE TEST</b>	
6.1 INTRODUCTION	6 - 1
6.2 GENERAL PRINCIPLES AND PROCEDURES	6 - 1
6.3 TOOLS AND TIME REQUIREMENTS	6 - 3
6.4 THE STEP-BY-STEP TEST	6 - 3

**7. HEAT EXCHANGER LEAKAGE**

7.1 INTRODUCTION	7 - 1
7.2 TOOLS AND TIME REQUIREMENTS	7 - 2
7.3 THE STEP-BY-STEP TEST	7 - 3

**8. REMEDIAL MEASURES**

8.1 INTRODUCTION	8 - 1
8.2 DISCUSSING VENTING WITH A SUPERVISOR	8 - 2
8.3 DISCUSSING VENTING SAFETY WITH THE HOMEOWNER	8 - 2
8.4 REMEDIAL MEASURES	8 - 3

**APPENDIX A**

ACT CHECKLIST	A - 1
VENTING SYSTEM TEST CHECKLIST	A - 3
VENTING SYSTEM TEST REPORTING FORM	A - 5
CHIMNEY PERFORMANCE TEST	A - 8
HEAT EXCHANGER LEAKAGE TEST CHECKLIST AND REPORT FORM	A - 8

**APPENDIX B DISCUSSION OF REMEDIAL MEASURES**

B.1 INTRODUCTION	B - 1
B.2 CONSIDER SIMPLE SOLUTIONS FIRST	B - 1
B.3 NEW APPLIANCES	B - 1
B.4 DISCONNECT OR LABEL EXHAUST DEVICES	B - 2
B.5 PASSIVE & ACTIVE MAKE-UP AIR DUCTS	B - 2
B.6 COMBUSTION AIR DESIGN REQUIRED BY CODES	B - 6
B.7 SEALED AND ADJUSTED AIR CIRCULATION SYSTEMS	B - 10
B.8 FLUE TIGHTENING AND INSULATION	B - 14
B.9 SEALED CHIMNEY LINERS	B - 16
B.10 IMPROVED VENT CONNECTORS FOR DHW HEATERS	B - 19
B.11 DEALING WITH LEAKY HEAT EXCHANGERS	B - 20

# **1. INTRODUCTION**

## **1.1 PREFACE**

This manual has been prepared for Canada Mortgage and Housing Corporation in cooperation with the Canadian Gas Association to provide heating service technicians with the most up-to-date information available on the venting of the products of combustion of conventional (naturally aspirated) gas and oil fired appliances. It is intended to be used as both a student text and as a reference manual.

As a service technician, this manual will be a valuable tool, friend and teacher. It is a tool that will help you do your job better and increase the safety of the heating systems upon which you work. As a friend, it will help keep you out of trouble. It is your job to ensure that heating systems are as safe as they were intended to be and this manual will help you do that. As a teacher, this manual will explain how to determine if a heating system is safely venting the products of combustion to the outdoors and what to do about it, if it is not.

In recent years there has been considerable research conducted on all aspects of house structure and systems. This research has resulted in two important changes in how we should view a house. Most importantly, we learned that what many people thought of as a simple heated or cooled box with people inside is, in fact, a complicated structure with many interacting systems. These interacting systems are really a group of sub-systems, that when all combined, make a house, hence the term, "house-as-a-system." To understand how the heating system works, one must understand how the house system (and its many interacting subsystems) works. This manual will provide a brief over-view of a house-as-a-system and if you have not been exposed to this concept before, you should find it very interesting.

The manual describes the proper operation of a chimney and the symptoms of spillage of combustion products. The authors have included checklists that can be used to determine whether a venting problem exists. The manual provides test procedures for the service technician to evaluate a combustion venting system and to detect a leaking heat exchanger. Remedial measures, to solve problems once they have been detected, are also discussed in some detail.

The premise of the manual is that if because of either an occupant smell/odour complaint or because of symptoms present, the service technician is suspicious that the combustion venting system may not be operating as intended, a simple "Assessment, Check and Test" (ACT) procedure should be followed. This simple ACT process is designed to determine if there is a problem or whether more extensive testing is required. In the majority of cases, only the simple ACT procedure will be required, however, if more time consuming and complex tests are required, the manual provides instructions on how to complete and evaluate those tests.

## 1.2 BACKGROUND

The burning of a fuel, be it gas or oil, is in fact a chemical reaction. In the process, the chemicals or molecules in the fuel are rearranged and recombined. During this chemical reaction, a significant amount of heat is produced; heat we use to heat our homes and domestic hot water. Most of the new compounds produced will provide no direct health or safety problems for humans (water and carbon dioxide), except at very high concentration levels. Some of the products of this chemical reaction may pose a health or safety problem after prolonged exposure or exposure to high concentration levels (the nitrous oxides, but most importantly, carbon monoxide). Nitrous oxides can cause eye and respiratory irritation and carbon monoxide can cause death if the concentration is high or if the exposure period is lengthy.

None of these products of combustion pose any threat to the occupants of a house where the heating system is operating properly. It is only when something significant goes wrong that problems arise and the major problem of concern being addressed by this manual is the spillage of these combustion products into the home. This spillage usually occurs for one of four reasons:

- 1) A blocked chimney
- 2) Insufficient chimney draft because of poor chimney design
- 3) Insufficient chimney draft because of competition with other exhaust devices
- 4) A leaky heat exchanger

In the early 1980s, the house building industry became concerned about the potential for spillage of combustion products in houses. A study conducted for Canada Mortgage and Housing Corporation (CMHC) in 1983 found that carbon monoxide poisoning resulting from the inadequate exhaust of combustion products from fuel-burning appliances (those using oil, natural gas, propane, wood or coal for fuel) was responsible for a number of cases of carbon monoxide poisoning across Canada.

The study concluded that the main causes of these carbon monoxide poisoning incidents were:

- equipment problems due to poor maintenance, damage and defects (such as collapsed, blocked, dislodged or damaged chimneys, vents and flues);
- in a very few cases, down-drafting of combustion products in chimneys, vents and flues due to excess exhaust of air from the house, inadequate air supply, and air-tightness of the house envelope (though spillage has not resulted in many deaths in the past, the trend to tighter houses has the potential to make it a more common occurrence); and
- improper installation of equipment, chimneys, vents and flues.

### 1.3 EXPLANATION OF TERMS

**Backdrafting:** a condition where all of the flow in a flue is downwards and all of the combustion products from connected appliances, if operating, flow out their dilution devices, along with the backdrafting air.

**Building Envelope:** the parts of a building that separate heated (or cooled) space from the outdoors. The building envelope usually consists of roofs, walls, windows, doors, basement walls and basement floors.

**Chimney:** a nonflammable structure, containing one or more flues that carry combustion products to the outdoors.

**Combustion Air:** air supplied to a fuel-burning appliance to facilitate the burning of the fuel.

**Combustion Products:** the gases released from the combustion of a fuel. These include carbon dioxide, water vapour, and varying amounts of carbon monoxide, sulphur and oxides of nitrogen.

**Dilution air:** air used by a venting system to control the draft at the exit from the heating appliance.

**Dilution, or Draft Control, Devices:** devices that admit room air into the venting systems to mix with the products of combustion for the purpose of controlling the draft at the flue collar. These devices include draft hoods (draft diverters) on gas appliances, and barometric dampers on oil-fired equipment.

**Draft:** the "driving pressure" that causes air and combustion products to flow in a venting system.

**Vent:** a passage in a chimney through which products of combustion are carried from a fuel-fired heating appliance to the outdoors.

**Vent Collar:** the ring at the exit of the heating appliance onto which the flue pipe, or vent connector, is attached.

**Vent Connector:** the conduit connecting the vent collar of a heating appliances to a chimney. The term smoke pipe is commonly used by the oil heating industry. Vent connector is commonly used in the gas heating industry.

**Fuel-fired Heating Appliance:** a heating appliance that uses a fossil fuel (e.g., oil, natural gas, wood, propane, or coal) to produce heat for the purpose of heating a house.



**Make-up Air:** air that is brought into the building to replace air that is being exhausted by mechanical exhaust devices and/or combustion appliances.

**Pressure-induced Spillage:** spillage caused by house and/or furnace room depressurization produced when the demand for indoor air by exhaust devices exceeds the air supplied to the space through cracks and holes, or intentional openings, in the building envelope.

**Smoke Pipe:** the pipe that connects the breach of an oil fired appliance to the chimney (this term is being phased out and replaced with the term "vent pipe").

**Spillage:** the flow of combustion products out of dilution device of a combustion appliance or out of leaks in its venting system into the room where the appliance is located.

**Ventilation:** the provision of fresh outdoor air fit for breathing, to an indoor environment.

**Venting:** the direct removal of the products of combustion from an indoor environment by "capturing" or collecting them where they are generated and exhausting them to the outdoors.

**Venting Systems:** the systems that is responsible for removing combustion products from the combustion chambers of a heating appliances to the outdoors. It normally includes the flue collar, the vent pipe or vent connector, and the chimney (or "A" or "B" vent).

\* naturally aspirated gas and oil fired appliances

## **2. HOUSE AS A SYSTEM**

### **2.1 The Concept**

Houses are built to provide protection from the elements and to provide a comfortable and safe indoor environment. In the past, the cost of energy was low, and little if any consideration went into how much energy houses consumed. Since these houses were so inefficient, they were usually "forgiving" so contractors called in to do a specific task in these homes didn't need to concern themselves with anything except the job they were working on at the time.

When energy prices began to rise and the cost of providing a comfortable indoor environment soared, people began to retrofit their homes with insulation, air sealing materials and new heating systems in order to protect themselves from escalating energy costs. As a result of this air sealing work, it became possible to exercise more control over the temperature, humidity and air movement in the house. However, many new and existing houses are now sealed to the extent that they may, if proper attention is not given to the mechanical systems in the house for example, have a negative impact on the indoor air quality, structural integrity and most importantly, the availability of air for the safe operation of fire places and the ability of combustion appliances to vent the products of combustion.

The three components of the house system - envelope, occupants, and the mechanical system in conjunction with the outdoor environment, create the total system within which each of these subsystems interact.

The interactions between the envelope, occupants and mechanical systems of a house allow us to see "the house as a system" rather than the simple sum of its component parts or sub-systems. Since the system and the subsystems interactions are sometimes difficult to completely understand, it is not possible to predict with absolute certainty, which houses will have problems with the venting of combustion products and which won't. Though it may not be possible to predict whether a house is likely to have such problems with absolute certainty, understanding the house as a system does make it possible to recognize those houses that may have a potential problem and those houses that will not.

## **2.2 Introduction**

The basic building science principles which need to be understood in order to understand the concept of the house as a system relate to the following three forces that occur in every building environment:

1. Heat Flow
2. Air Flow
3. Moisture Flow

It is the dynamics between these three interrelated forces that determine the state of the house system at any given moment in time. The objective is to create a condition which maintains the structural integrity of the house over time, while affording safety and comfort to the building occupants at a minimum cost to the homeowner. While moisture and heat flow are an important consideration when making alterations on the house as a system, for the purposes of this manual it plays a minor role and will not be discussed. Air flow, however, can have a significant effect on the combustion venting process.

## **2.3 Air Flow**

In much the same manner, as heat flows through a material because of a temperature difference, air will flow into or out of a structure due a difference in air pressure. Air flows from higher to lower pressure (See Figure 2.1.).

Pressure differences result from:

- the difference between indoor and outdoor air temperature  
(The resulting pressure difference produces the so-called stack effect);
- wind direction and velocity;
- ventilation and exhaust fans; and
- the operation of chimneys for combustion appliances or fireplaces.
- leaks in the ductwork of a forced-air heating system

The number, size and location of holes in the envelope, while these do not generate air flow by themselves, significantly affect the volume of air flow resulting from the other factors in this list. No air flow will occur if there are no holes through which the air can pass. Air flowing in through these openings is called "infiltration" and air flowing out is called "exfiltration".

These factors influence the air flow in all houses, therefore, they must be taken into account when assessing air flow conditions in a given house.

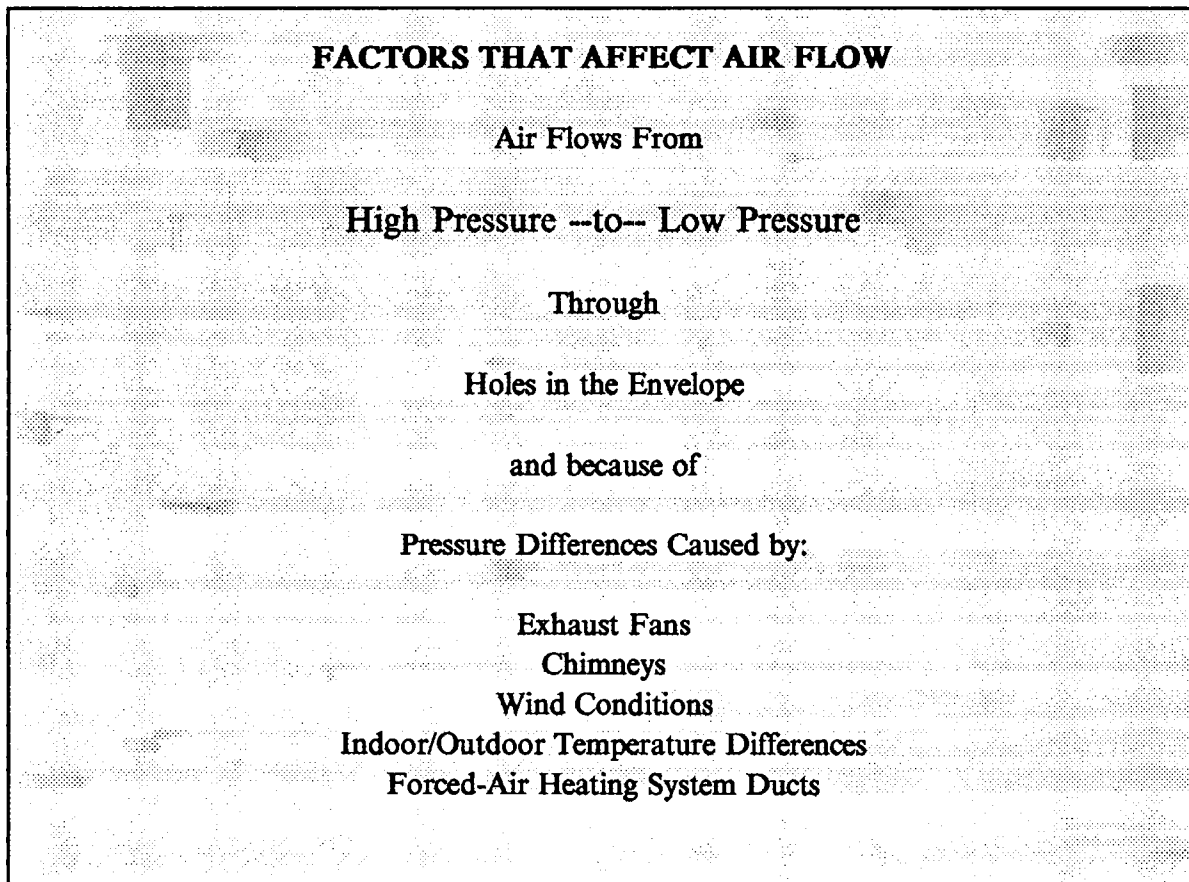

**Figure 2.1 Air Flow Factors**

## **2.4 Stack Effect**

The difference in temperature between indoor air and outdoor air creates a pressure difference due to the difference in air densities. The pressure difference causes the house to act as a large chimney -- cold air enters or infiltrates through holes in the lower levels, is heated, rises, and exits or exfiltrates through the upper levels. This is called the stack effect (See Figure 2.2). An example can be found in many two or three storey houses where the windows on the lower floor(s) are clear and those on the upper floor have condensation on the inside surface of the outer glazing of double glazed windows. Warm, moisture laden air is leaking out of the upper storey window and the moisture is condensing on the inside of the cold outer glass pane.

The level at which infiltration changes to exfiltration is called the "neutral pressure plane". Its location changes with conditions. The greater the temperature difference between the indoor and outdoor air, the larger the stack effect.

**FIGURE 2.2 THE STACK EFFECT**

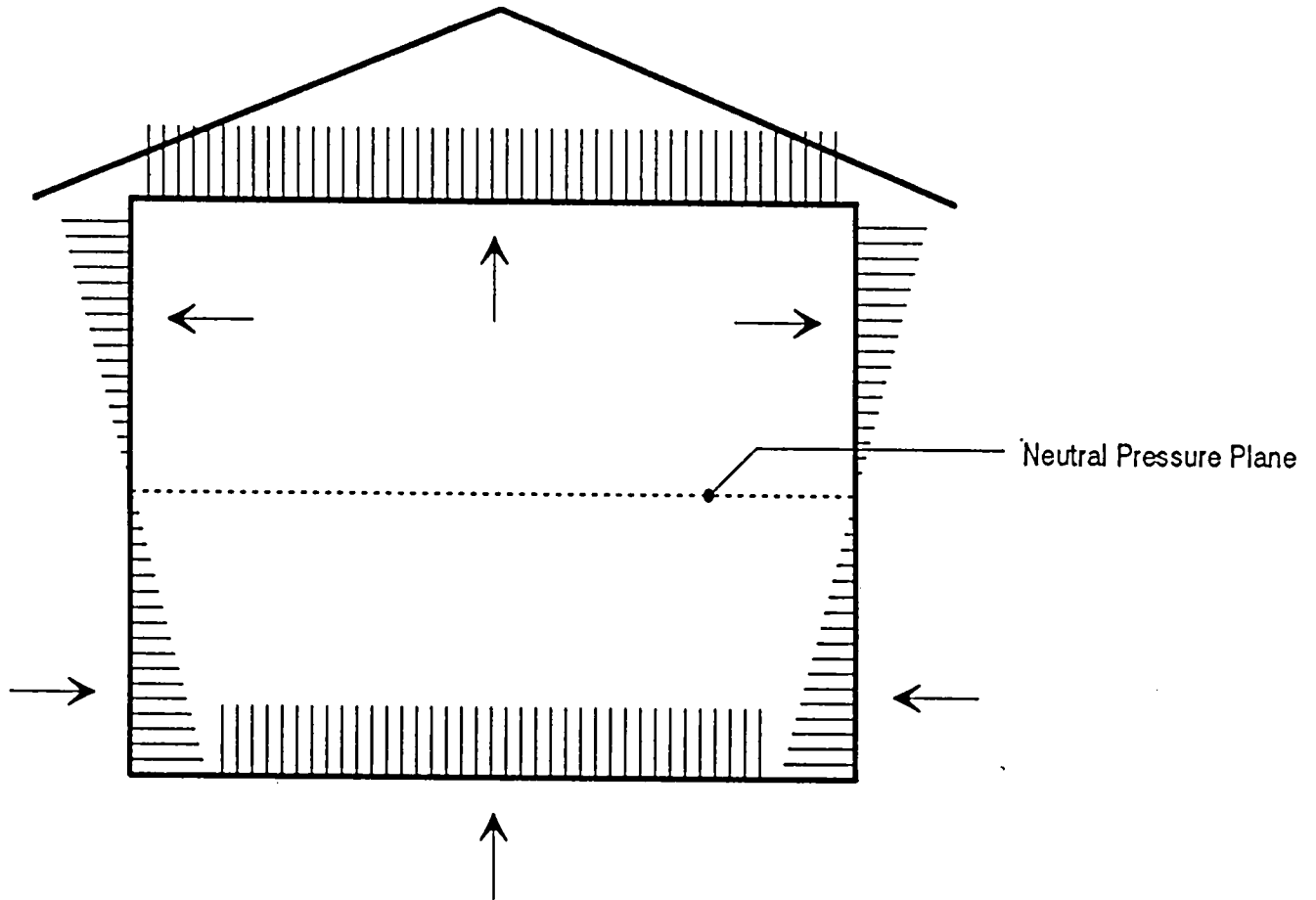

## **2.5 Wind Effect**

Wind causes positive pressure on the windward side of the house and negative pressure (suction) on the leeward side and sides parallel to the direction of flow (See Figure 2.3.).

Pressures inside the house due to wind action depend on the resistance to flow of cracks and openings in the building exterior and their location in relation to wind direction. Pressures must adjust so that inflow equals outflow. Wind action does not usually pressurize or depressurize the house, however, if most of the openings occur on the windward side, pressures inside the house will increase. The converse will occur when most of the openings are on the leeward side. The overall effect of wind action is that there may be localized "pockets" of positive pressure in some areas of the house, but these will be balanced by negative pressures in other areas.

## **2.6 Distribution System Effect**

Forced-air heating systems distribute warm air through pressurized supply ducts and return cool air through depressurized return ducts. Since most return-air systems utilize a joist space over which sheet metal is nailed, it tends to be very leaky but because the return duct system is depressurized, that is, it contains a negative pressure, air does not leak out of the return system, it leaks in, usually from the basement (See Figure 2.4), and this enhances the stack effect by further depressurizing the basement. The effect can be compounded by basement return-air inlets, poor fitting external furnace filter assemblies and leaky furnace blower doors.

## **2.7 Flue and Ventilation Effects**

A fourth effect, which may not be so obvious, is the pressure difference caused by a combustion appliance or fireplace with a chimney. The heating appliance or fireplace takes in air for combustion and dilution which causes a lower pressure in the house, usually in the basement in the case of the furnace (The amount of depressurization caused by a gas or oil furnace or boiler is very small compared to an open fireplace.). This causes increased infiltration. The process is called the Flue Effect (See Figure 2.5.).

The Ventilation Effect results from the operation of mechanical devices that exhaust air. Common examples are bathroom fans, kitchen range hoods, clothes dryers and central vacuum systems. These devices, when operated, expel air from the house and reduce the indoor air pressure. This "ventilation effect" is similar to the flue effect described above. By removing air and reducing indoor air pressure, it causes an equal amount of air to infiltrate.

When household exhaust equipment, such as exhaust fans, clothes dryers, and fireplaces, operate, they blow air out of the house. This lowers indoor pressure relative to the outside. This

**FIGURE 2.3 THE WIND EFFECT**

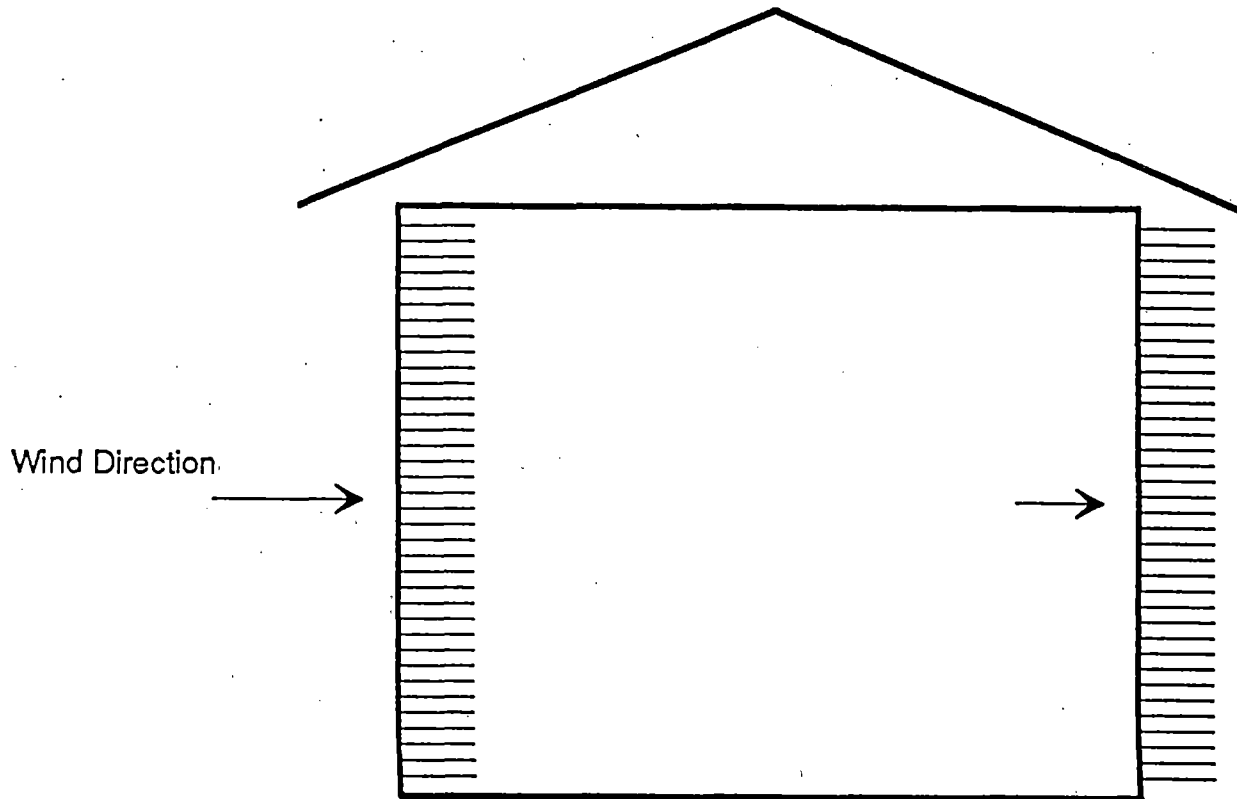

**FIGURE 2.4 THE DISTRIBUTION SYSTEM EFFECT**

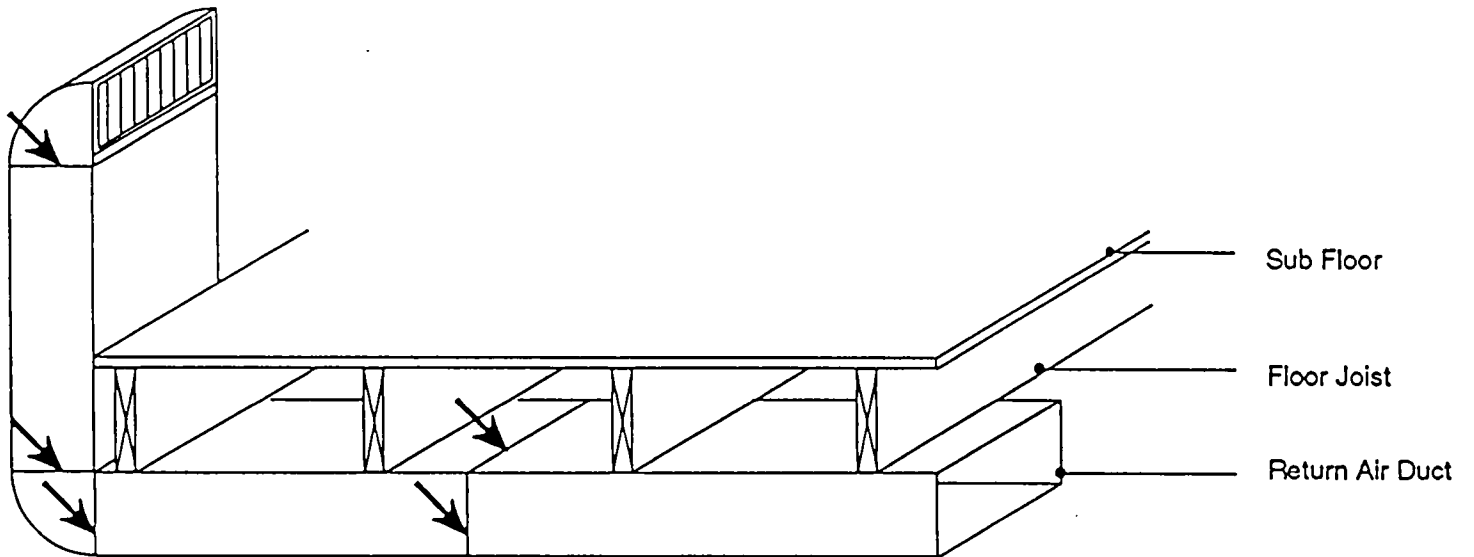

Air is drawn into the return air system from the surrounding space. This may cause a negative pressure to be created in the surrounding space, most often the basement.

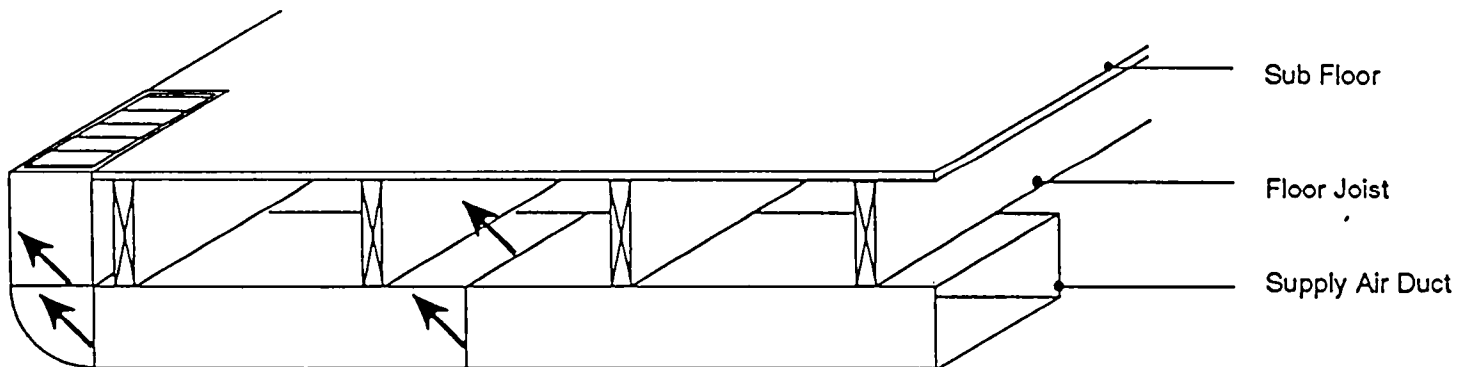

Air leaks out of supply air ducts into the surrounding space. This may cause a positive pressure to be created in that space.



**FIGURE 2.5 THE FLUE AND VENTILATION EFFECTS**

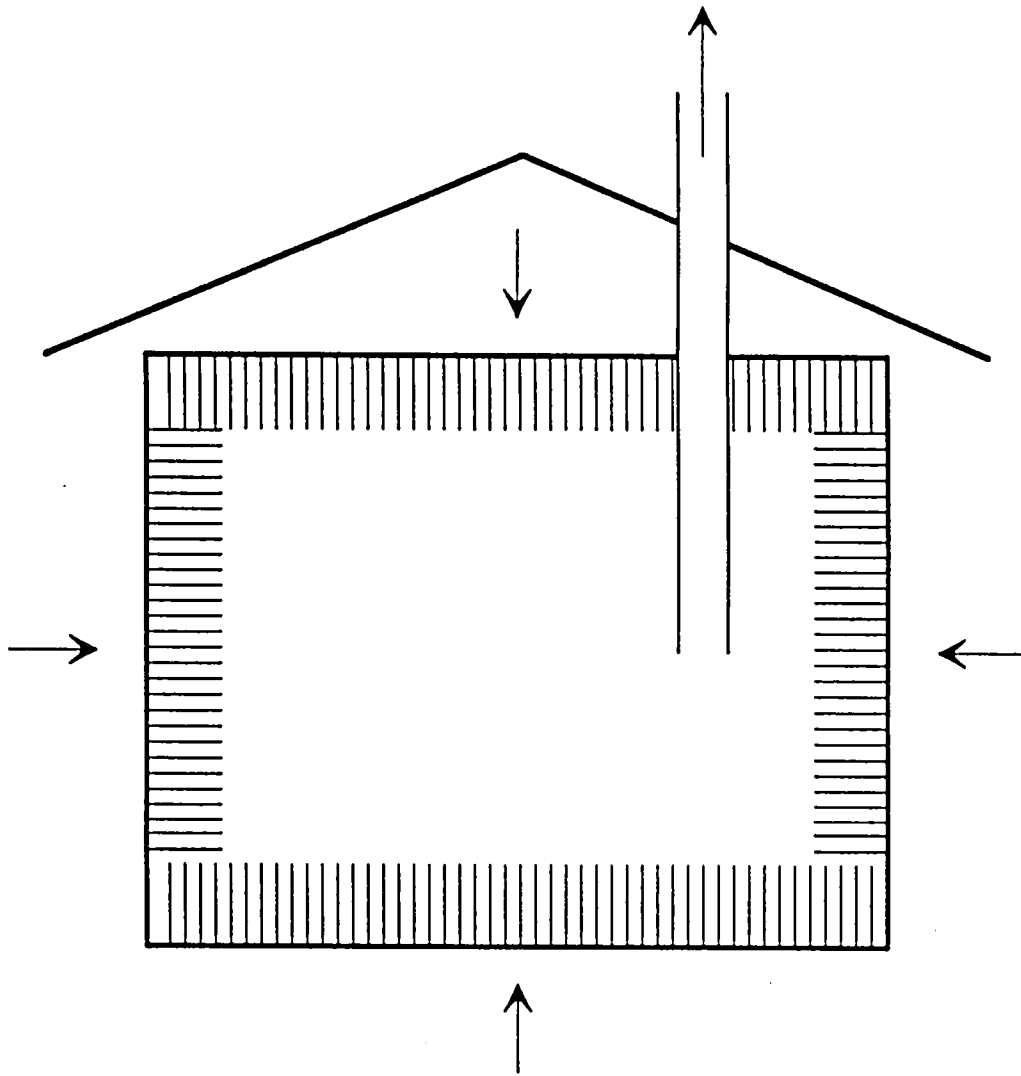

lowering of indoor pressure is referred to as "house depressurization". The amount of house depressurization that occurs depends on the number and capacity of the exhaust devices in the house and the tightness of the building envelope. The greater the exhaust, and the tighter the building, the more a house will be depressurized.

As house depressurization increases, the chimney must increasingly compete against the suction exerted by the exhaust devices and hence becomes less and less capable of venting all of the combustion gases it was installed to vent. In some cases, house depressurization is great enough to cause the flow of combustion gases in the chimney to reverse. This results in a backdraft situation in which all of the combustion gases are spilled into the house rather than being safely vented up the chimney. However, this is unlikely to occur once the heating appliance is actually operating since the chimney is warm and its draft is high. Reversal of chimneys during heating appliance operation is rare. Chimneys are least effective in combatting house depressurization when they are cool, since cool chimneys have weak draft. For this reason, it is most common for chimneys to backdraft when the heating appliance is not operating. When the appliance eventually begins to operate, it must fight against the backdrafting current of cold air. Often an appliance will spill for prolonged periods of time into the house before it manages to re-establish an upward draft in the chimney. Spillage produced in this manner can be referred to as "pressure-induced" spillage since it is the depressurization created by the operation of household exhaust devices which causes the spillage to occur.

## **2.8 Combined Effect**

The combined effect on air flow of the united action of stack, distribution system, flue, ventilation and wind effects will change as environmental factors (outdoor temperature, wind, etc) change. The combination of the individual effects is illustrated in Figure 2.6.

The neutral pressure plane, as described earlier, tends to rise whenever the indoor air pressure is reduced. The operation of exhaust devices will therefore cause the neutral pressure plane to rise. When a house is operating normally, with the heating appliance cycling and the various ventilation devices being used intermittently, the flue effect and ventilation effect combine together to create a powerful exhaust of air out of the house. Large volumes of air must infiltrate to replace the exhausted air. The combined effect will usually be enough to overcome the stack effect. In such cases, the air pressure even in the upper floors is reduced to the point where air is drawn inward through all parts of the building envelope. The neutral pressure plane under these conditions rises above the building envelope.

Under such conditions, air flow in the chimney can be reversed and the products of combustion may spill into the basement. This condition is called "back-drafting". If this occurs for extended periods, the consequences can be quite serious; for example, carbon monoxide poisoning.

**FIGURE 2.6 THE COMBINED EFFECT**

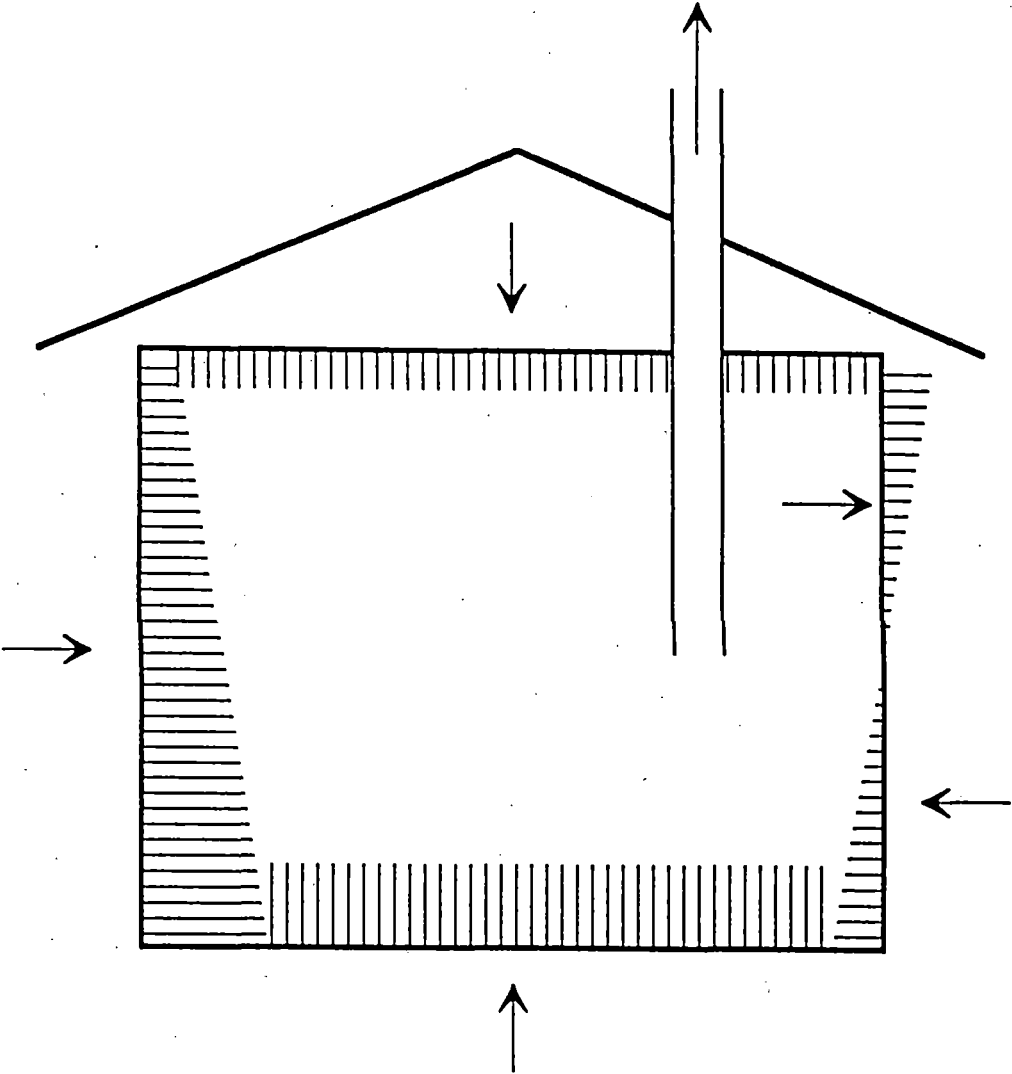

### **3. OVERVIEW OF THE COMBUSTION VENTING SYSTEM INSPECTION, ASSESSMENT AND TESTS**

*This chapter will discuss the venting system Assessment, Check and Test (ACT) and when the "ACT" should be performed.*

#### **3.1 Introduction**

Why worry about combustion gas spillage? Short periods of spillage of combustion products from an otherwise properly operating gas or oil fired appliance may not cause any health or safety problems, however, if the spillage time is lengthy, frequent or if the appliance is not operating properly, there may be a potential health or safety hazard.

If a venting system is operating properly, all of the products combustion will be vented to the outdoors. Usually there is a natural draft of warm air rising up the chimney, even when the heating appliance is off. In some cases, where the natural draft up the chimney is slight, non-existent or reversed, it may take the heating appliance up to 30 seconds to establish proper draft. During this time, a positive pressure builds-up in the appliance and vent connector/smoke pipe. If this happens, spillage may occur through leaks in the appliance cabinet, the draft hood, barometric damper or joints in the vent connector pipe. This short term spillage is not of major concern (although if it is one of several symptoms of a potential problem and further tests should be conducted) and may be the norm for the installed system.

Two things must go wrong with a heating system at the same time to produce a life-threatening situation. Those two conditions are:

- 1) The spillage incident, or event, must occur for a prolonged period;
- 2) The spillage products must contain or include carbon monoxide.

Though the products of combustion from a properly tuned gas or oil fired appliance may contain carbon monoxide at levels so low that they are almost immeasurable, prolonged spillage may result in most of the oxygen in the appliance area being consumed or replaced by carbon dioxide. The length of time that this will take will depend upon the leakiness of the furnace area, the amount of spillage occurring and whether the spillage is being diluted by fresh air supplied to the furnace area through a combustion air intake.

With complete combustion, two atoms of oxygen join with one of carbon to form carbon dioxide (CO<sub>2</sub>). If there are not enough oxygen atoms, because they have been replaced with spilling combustion products in the appliance area, only one oxygen atom will link with the carbon, creating the poisonous and odourless gas, carbon monoxide (CO). If the spillage event continues such that carbon monoxide is being released into the house, a life-threatening situation can result. This phenomena is more likely to occur when the heating appliance or domestic hot water heater (DHW) is located in an enclosed room. In such a situation, the products of combustion will not be diluted during a spill and most of the oxygen in the room will be used-up quickly.

The purpose of the "Assessment-Check-Test" (ACT) procedure is to provide a simple sequential series of actions that will allow a service technician to quickly identify combustion venting problems or the potential for such problems. An ACT Checklist is provided in Appendix A of the manual. Use of this checklist will ensure that ACT is completed quickly but thoroughly and will help to record the findings. It is recommended that the service technician photocopy the checklist and carry a number with him in the truck.

At the very minimum, the venting system should be checked for adequate draft during every "regular hours" service call and if the chimney is masonry, it should be checked both from the outside and through the clean-out door. If the owner or occupants are home, they should be questioned briefly to determine if they have noticed any symptoms of combustion products entering the house (eg: odours when the heating appliance starts, excessive moisture in the house, or persistent headaches or other health problems during the heating season).

It is not necessary to carry-out the full ACT procedure during every service call, however, it is recommended the Assessment, Checks and Tests included in the "ACT" procedure be performed in the following situations:

- \* The purpose of the visit is a Fumes, Leak, Odour or Moisture (FLOM) complaint;
- \* During a normal heating appliance service call the venting system exhibits a poor draft, the occupants indicate symptoms of spillage or the chimney appears to be in poor condition;
- \* If possible, during an annual or periodical maintenance or tune-up is being conducted;

If it has been determined during a normal service call that a venting system problem may exist, the ACT procedure should be implemented. It is suggested that the owner be informed that as part of the company's regular service it now likes to perform a few extra safety checks to make sure the chimney is working properly. It could be pointed out that this extra service could detect problems such as a blockage caused by birds or squirrels, a not uncommon experience which can have disastrous results if not detected.

## 3.2 An Overview of "ACT"

The following Assessment, Check, Test (ACT) procedure must be carried out if any of the above triggers are present. The "ACT" procedure is not always an end in itself, but it will help to determine if there is a combustion venting problem and will focus the service technician's investigation in the right direction so appropriate further testing can be conducted, should that be necessary.

### \* Assessment

The service technician must assess the house as a system. Basically, the service technician is assessing the house to determine if there is a possibility that it is relatively airtight, and/or whether there are other exhaust appliances that may compete with the heating appliance for air. Such an assessment requires the service technician to ask the occupants a few simple questions that may indicate symptoms of potential spillage of combustion products, and to do a quick walk-through or assessment of the house. This assessment will be discussed in more detail in Chapter 4.

### \* Check

The Chimney Check part of the "ACT" procedure requires the service technician to conduct a visual inspection of the combustion venting system. In most cases this will simply mean removal of the clean-out door or the vent connector/smoke pipe to inspect the chimney with a mirror and in some cases a flashlight. With gas-fired systems using B-Vents, if a draft test indicates that there is adequate draft, the vent connector need not be removed for inspection. Most life threatening heating system safety hazards result from blocked or obstructed chimneys. *This may be the most important check made during the visit and must always be performed and never taken for granted.* If the purpose of the visit is a "FLOM" complaint or if other symptoms of spillage have been detected, houses with B-Vents should have the vent-connector removed so that vent can be inspected for a blockage.

Heat exchanger leaks or cracks will allow undesirable products of combustion to enter the residence, either through the air distribution system or out the barometric draft control when the air circulation blower is operating. A heat exchanger leakage test will not always be required as part a normal service or maintenance visit, however, the heat exchanger should be tested, with the owner's permission, if certain problems are encountered. See Section 3.5 for more details.

### \* Test

The "ACT" procedure includes a simple combustion spillage test. This quick test requires that all doors and windows be closed and all exhaust appliances be activated. A test with a draft detector (smoke pencil) will determine if any spilling of combustion gases is occurring. This test, which is only effective when outdoor winds are light, will indicate if

the heating appliance is losing the competition for air. However, under most weather conditions, it may detect a blocked or poorly performing chimney and may also indicate if the appliance itself is venting properly. Though this test is most meaningful under light wind and moderate temperature conditions, it should still be conducted when ever carrying-out the ACT process.

**If "ACT" indicates that there is a problem, one or more of the following tests, as appropriate, should be conducted.**

### **3.3 Venting System Test (See Chapter 5)**

If the house as a system **Assessment** indicates that there is a potential for the spillage of the products of combustion or if the **Spillage Test** has detected spillage, the homeowner should be notified and a **Venting System Test** strongly recommended. This test uses house depressurization measurements to determine the potential for backdrafting problems. The main advantage of this test is that it can predict venting problems that might occur under worst case conditions, even if such conditions are not present during the test.

### **3.4 Chimney Performance Test (See Chapter 6)**

If spillage was detected during the "ACT" Test, no chimney blockage was found during the "Check" and the **Venting System Test** indicated that the basement was not sufficiently depressurized to normally cause the spillage that was occurring, the **Chimney Performance Test** should be conducted. The purpose of this test is to determine if the chimney is performing as it should. This simple test requires the measurement of the static pressure in the chimney and the temperature of the products of combustion in the vent connector or smoke pipe.

### **3.5 Leaky Heat Exchangers (See Chapter 7)**

Leaky heat exchangers also pose a potential threat to health and safety. However, since testing for leaky heat exchangers is time-consuming and therefore costly to the homeowner, such tests should only be conducted when the symptoms described below are present. Recognition of such symptoms comes from an all-important homeowner/occupant interview and from a visual inspection of the heating system.

### Symptoms of a Leaky Heat Exchanger

- \* The homeowner reports odours during furnace operation or at start up.
- \* An O<sub>2</sub> or CO<sub>2</sub> test indicates that excessive dilution of the products of combustion is occurring after the air circulation blower starts operation.
- \* There is cause for reasonable suspicion - based on excessive moisture in the house, history of furnace type and customer complaints of symptoms (eg: odours when the heating appliance starts, excessive moisture in the house, or persistent headaches or other health problems during the heating season).
- \* There are sooty or oily deposits at duct joints or at the supply outlets.

If one or more of these indicators is present, the heat exchanger should be tested in accordance with the procedures described in Chapter 7. Though it will never be possible to detect every cracked heat exchanger during a regular service or maintenance call, some that are now being overlooked may be discovered.

### **3.6 Summary**

Completion of "ACT" takes little time and may result in the recognition of potential health or safety problems that might otherwise have been missed. If the house fails the "ACT", then further tests should be conducted.



## **4. THE "ACT" (ASSESSMENT, CHECK, TEST) DETAILED PROCEDURES**

### **4.1 The "ACT" Assessment**

The first step is a simple assessment of the house to quickly determine if the house is very leaky and to determine the number of exhaust devices which will compete with the furnace for air. This test does not preclude the administration of the following "ACT" Test nor the chimney inspection. For the purpose of this assessment, a house built after 1970 or a house in which all exterior walls are entirely covered with stucco should be considered to be tight. An older house that has been tightened through air sealing techniques or that has several exhaust devices, especially if their total exhaust capacity is high, may also have competition for air problems and some spillage of combustion products.

Once in the house:

- \* check the windows and exterior doors for tightness;
- \* ask the owner for the number of exhaust devices in the house (bathroom fans, range hood, kitchen BBQ, central vac venting to the outdoors, clothes dryer, fireplace that is used, etc.).
- \* look for a combustion air opening from the outdoors or some opening or grill in the door to a furnace room or in the wall separating the space from the balance of the house. If neither is present and the house is leaky, recommend the installation of a grille in the furnace room door. If a gas- or oil-fired heating appliance or DHW heater is located in an enclosed space, such as a furnace room, the potential for spillage of combustion products may be higher.
- \* if the house is tight, recommend that fresh air be ducted to the heating appliance or DHW heater. The size of this duct must meet and preferably exceed code requirements (The Code requirement is only sufficient to provide combustion air not the make-up air quantity required to maintain a neutral pressure within the house).

### **4.2 The "ACT" Check**

The chimney safety inspection is critical and must be conducted when ever the ACT process is being carried-out.

The "Check" portion of the ACT procedure requires that the following be done:

- \* Check the chimney from outside. Look for damage or efflorescence of masonry chimneys.

**\* Inspect a masonry chimney from clean-out door with a mirror and a flashlight, if required. If there is no clean-out door and the chimney is masonry, remove the vent connector or vent pipe to conduct the inspection.**

**\* Any debris found must be removed and investigated.**

**\* Check for symptoms of a cracked heat exchanger:**

**- on oil furnaces, black greasy or oily marks at duct joints or supply outlets.**

**- on gas furnaces, flames appear to be disturbed by air leaking from the heat exchanger.**

**\* Smoke pencil indicates air being blown out of the combustion chamber area when the fan is operating and the furnace is cool.**

Most chimney blockages occur in either unlined or clay lined masonry chimneys. Ideally all masonry chimneys should be lined. Unfortunately, in the real world, this is not always the case, often because of economic realities. Metal lined masonry chimneys are usually less prone to blockage due to the aging process, however, like other masonry chimneys, they should be inspected through the clean-out door, if one is present. Because of oil's greater tendency to produce soot when improperly tuned or maintained, the flue pipe should be removed so that a chimney inspection can be made if there is no clean-out area. The flue pipe should be removed and cleaned in any case, during an oil appliance's annual maintenance. If the required draft check indicates a poor draft or if the vent-cap is missing on a gas-fired system, the vent connector should be removed to inspect a B-Vent or metal liner for blockage.

**FIGURE 4.1.**

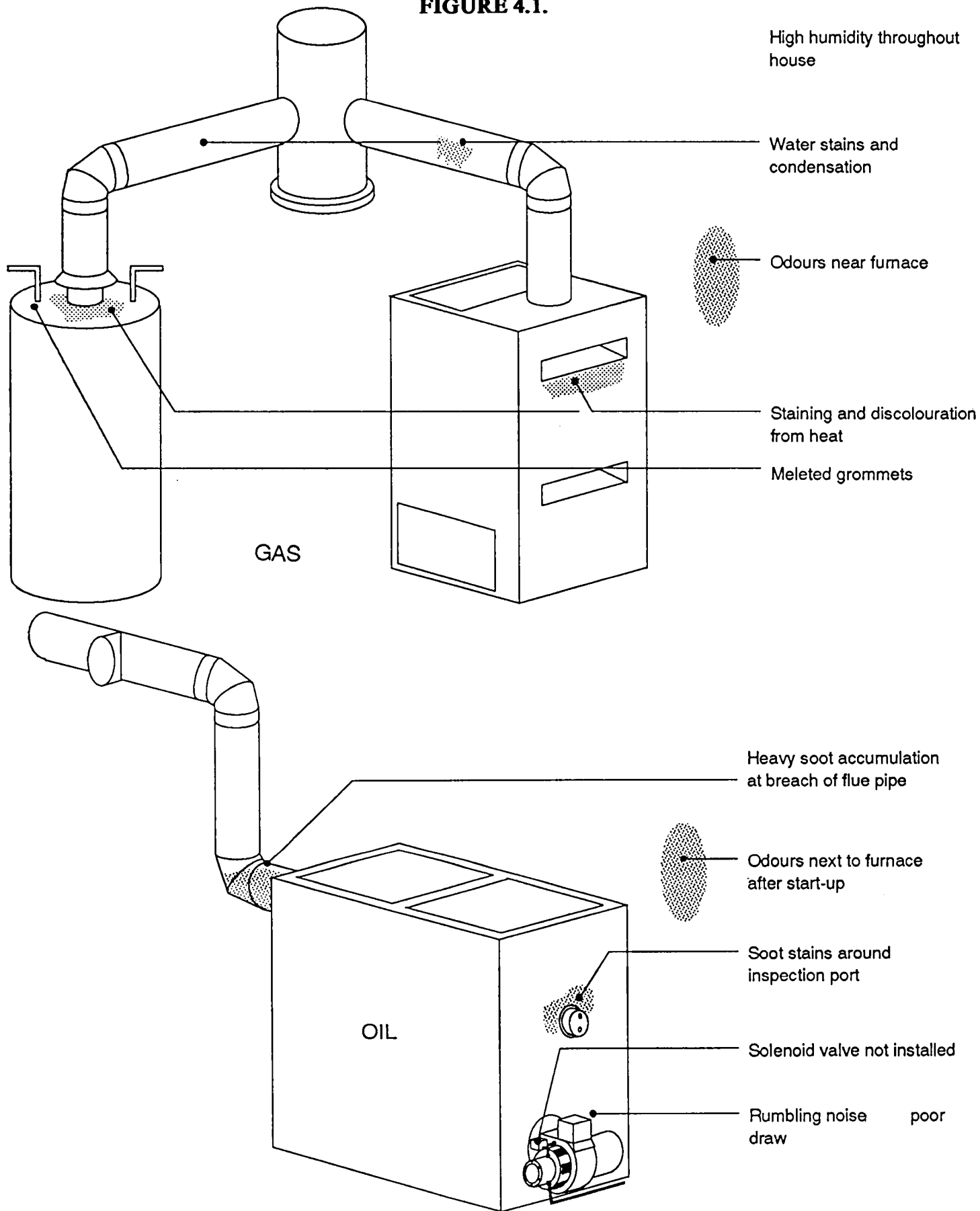

If a substantial amount of debris is found in the clean-out area, remove the debris and advise the homeowner that there may be a serious chimney problem that should be inspected and repaired immediately by a firm specializing in such a service. If the amount of debris found has accumulated to a level where it is blocking the passage of combustion products from the vent connector or vent pipe to the chimney, this combustion venting system would not have been working and your discovery, removal of the debris and advising the home owner, preferably in writing, to have the chimney repaired immediately, will likely have averted a potential health or safety problem.

Many chimney blockages result from causes other than chimney deterioration. Squirrels and birds will often make nests in chimneys during the "off" season. When the next heating season begins, the heating appliance will be unable to vent the products of combustion and spillage will occur. An inspection of the chimney through the clean-out or by removing the vent connector or vent pipe will often reveal such blockages. Inspect chimneys with off-sets very carefully because the off-set is often an ideal place to make a nest, yet is difficult to detect. A strong flashlight and a good mirror are required to properly inspect a chimney with an off-set.

Keep in mind that often you will find some debris in the clean-out of a masonry chimney that is the result of the chimney's original construction. With experience, you will be able to differentiate between construction debris and that caused by chimney deterioration. The debris from blockages caused by gas appliances attached to unlined masonry chimneys usually looks like a very coarse red sand. Blockages of clay-lined chimneys may occur due to the failure of the top tile. This can often be detected from the outside because the tile will no longer be protruding above the cap as it should.

### **4.3 The "ACT" Test**

#### **THE BASIC VENTING SYSTEM TEST**

The purpose of the **Basic Venting System Test** is to check for the possibility of combustion product spillage. The products of combustion may spill into the house due to negative pressures caused by the operation of exhaust devices and the lack of make-up air( air which replaces that exhausted by exhaust or ventilation devices. Spillage may also be caused by other factors such as chimney restrictions or termination positive pressure, etc.

Though this test is not a reliable indicator of spillage potential during periods of moderate to high winds or very cold outdoor temperatures, it is still a useful test and should be conducted during every ACT procedure. Chapter 5 presents a more comprehensive test method which may be necessary, however, it is not part of a normal ACT procedure and would only be conducted if "ACT" indicates that there may be a problem in a particular house.

**Figure 4.2 Signs of Damage to a Masonry Chimney**

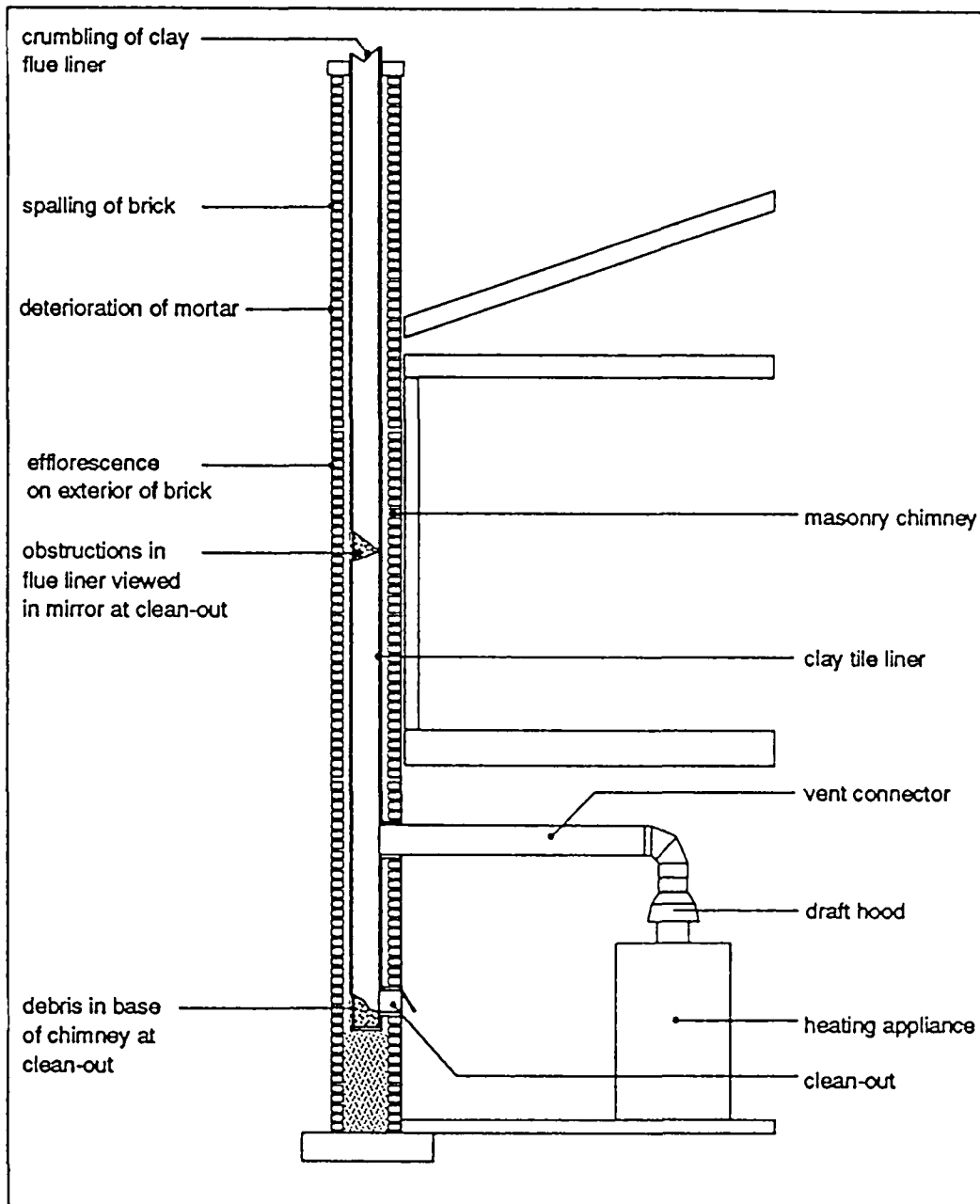

**Using the Smoke Pencil**

In order to conduct the test, a "smoke pencil", also referred to as an "air current tube" or a "draft detector", is required. They are available from safety supply stores. A typical smoke pencil is a glass tube, about the same size as a pencil, which is partially filled with a chemical. To use the smoke pencil, both ends of the sealed tube are snapped off. A rubber ball with a small hole fits over one end. Place your thumb over the hole in the bulb and squeeze it, this forces air through

the tube, and smoke is produced. Let your thumb off the hole in the bulb and let it fill up with air and repeat if more smoke is required. The path the smoke takes will enable the technician to determine whether or not spillage is occurring. Further details concerning where to use the smoke pencil are given in the next section. Immediately after finishing with the smoke pencil, cover the ends with the small rubber caps provided in the kit. This will save the smoke pencil for additional tests.

**Caution: Do not squirt the smoke directly at electronic components or at fabrics or furniture because the smoke of some air current detectors may be corrosive in high concentrations. If the glass tube containing the chemical breaks when attempting to open it, the contents may stain the surface that they fall upon.**

### **Preparation**

The first step of this Test is to ensure all the preparatory steps have been performed. These preparatory steps include:

- \* Recording the wind speed (calm, light, moderate or strong) and direction.
- \* Turning the furnace off with the manual switch located in the basement.
- \* Turning up the thermostat.
- \* Closing all exterior windows and doors to simulate winter conditions.
- \* Operate all exhaust devices and appliances including simulating a fire in all fireplaces or wood stoves with a two burner propane stove. A two burner camp stove should be sufficient. (This simulated fire should be started before turning on other exhaust devices.).

If the test conditions are less than ideal, conduct the test anyway. If no problems are found, but suspicion of a problem remains (See Figure 4.1.), recommend to the homeowner that the test be repeated under "better" weather conditions (better meaning worst-case conditions).

To conduct the Basic Venting System Test follow this procedure (See Figure 4.3.):

**FIGURE 4.3 BASIC VENTING SYSTEM TEST**

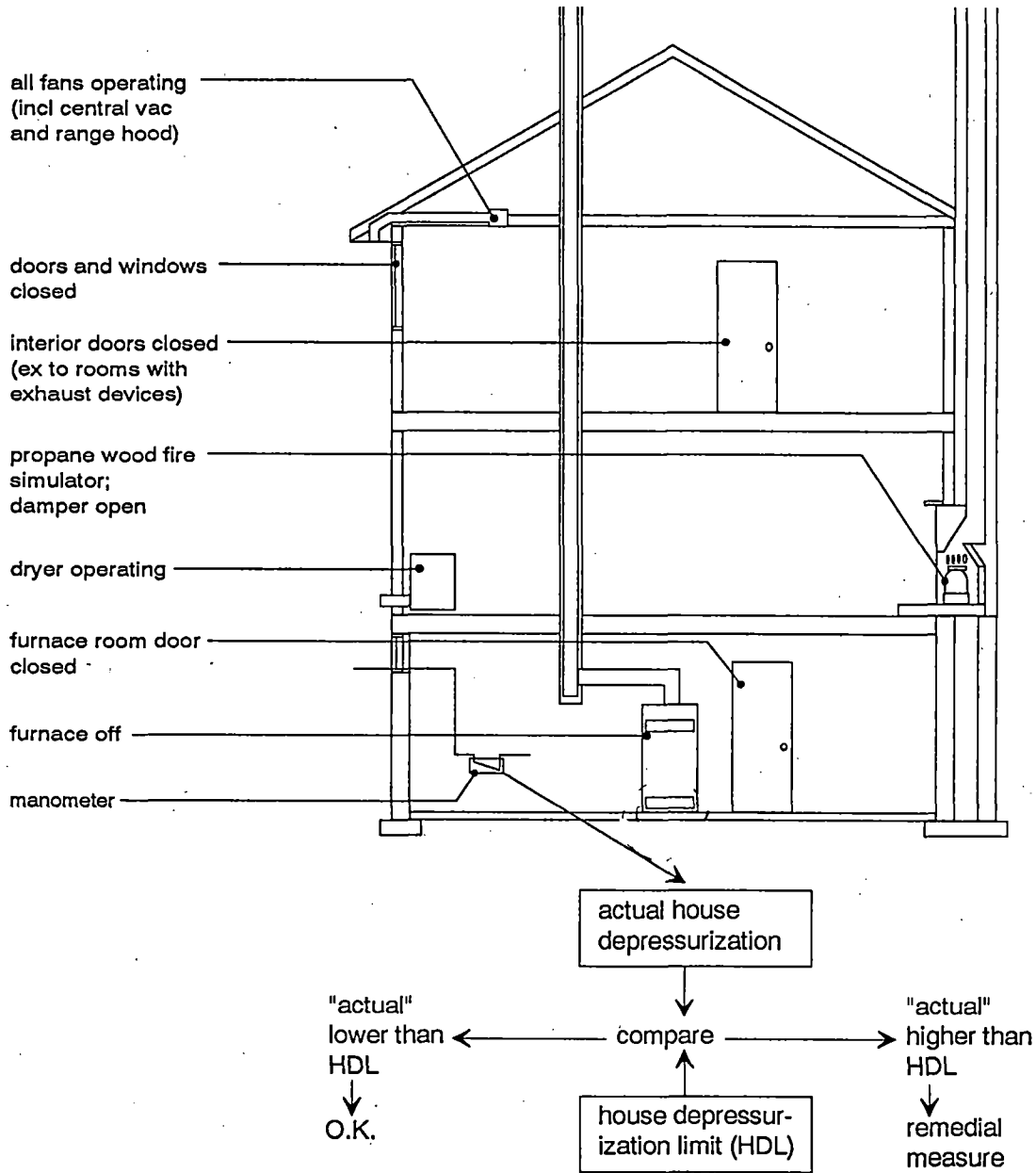

1. If the house has a fireplace or wood stove, open the chimney damper, insert a propane stove into the fireplace and ignite the burners to simulate a fire.
2. Turn on all exhaust devices throughout the house, including: bathroom and kitchen fans, indoor barbecue fans, clothes dryers, central vacuum systems that are vented outside, etc.
3. With the furnace, boiler and/or domestic hot water off, squeeze the smoke pencil to produce smoke at the following locations (See Figure 4.4.):

- \* for an oil furnace, boiler or domestic hot water heater, at the barometric damper, and the inspection door.

- \* for a gas furnace, boiler or domestic hot water heater, at the draft diverter or draft hood.

Note: On gas appliances, be sure to check for spillage across the total opening of the draft diverter or draft hood of both the heating appliance and the gas fired domestic hot water heater, if present. The reason for this is that it is possible that a draft hood or diverter could be drawing in air at one point and spilling at another. This is an unusual phenomena but it can be found in the field. The cause of this spillage out of one area of the draft diverter while another appears to be drawing in air can be caused by a leaky blower compartment sending air into the draft diverter.

4. Turn on the appliance and immediately check for spillage with the smoke pencil; you may require the homeowner's help to turn up the thermostat, if you have not already done so and are not controlling the appliance with a basement shut-off switch.
5. If spillage is occurring, the smoke from the smoke pencil will blow away from the furnace.
6. Note whether or not the spillage ceases within 30 seconds. If the spillage stops, the test is complete and the house passes, otherwise continue with the remainder of the test.
7. If no spillage is found during this test and if the service technician is fairly confident that there is no spillage problem, it is not necessary to conduct the "**Venting System Test**". If spillage was detected during this basic test and/or the service technician still has reason to suspect that a spillage problem exists, the **Venting System Test** described in Chapter 5 and/or the **Chimney Performance Test** described in Chapter 6 should be conducted.
8. Notify the homeowner in writing, of the **Basic Venting System Test** failure and recommend further testing or the application of appropriate remedial measures.



**FIGURE 4.4 Smoke Pencil Spillage Test**

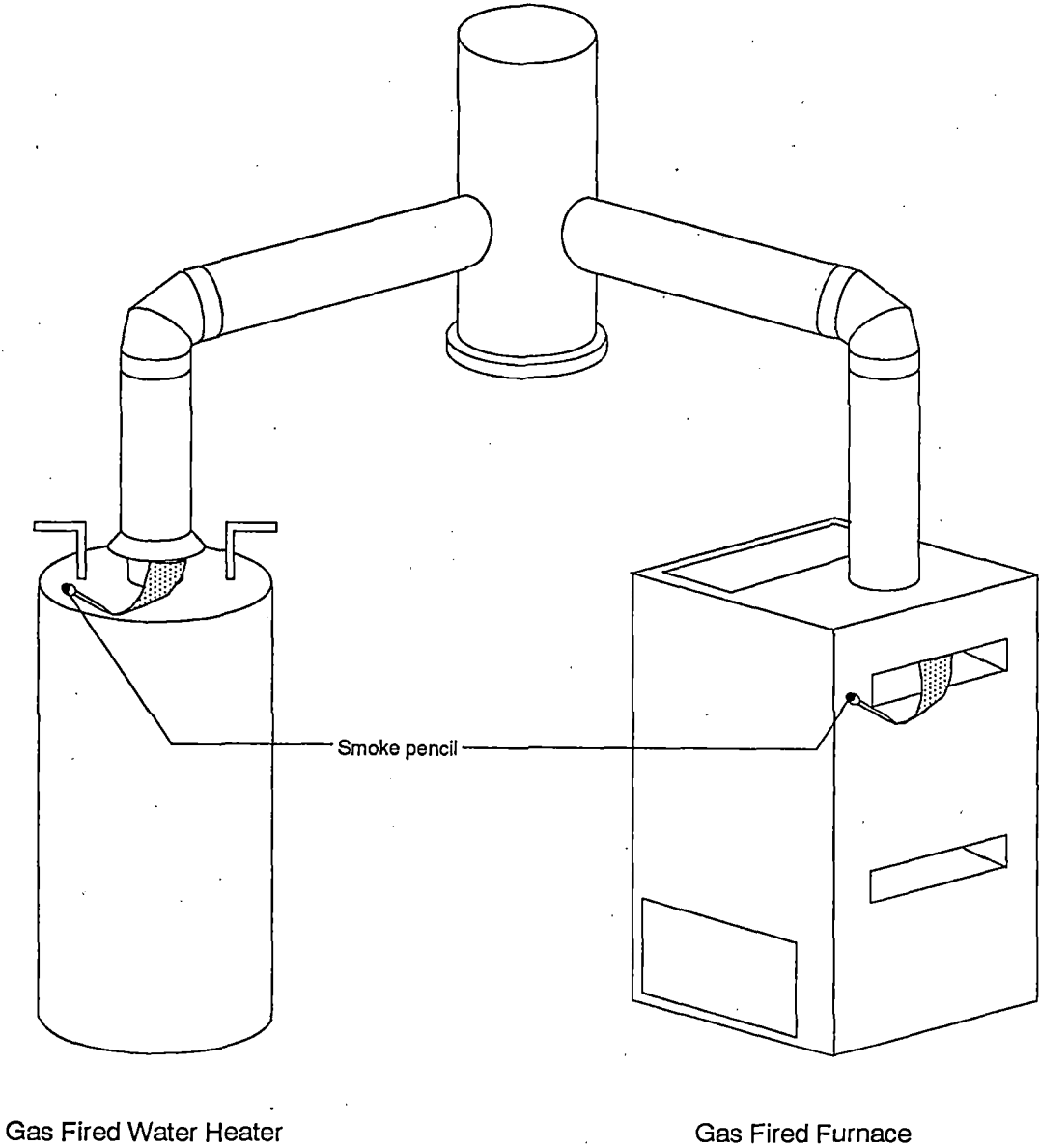

The **Basic Venting System Test** is now complete. The Service technician should turn the furnace back on, adjust the thermostat to the original setting, turn off all exhaust devices and the propane stove in the fireplace.

**ACT Checklist-** See appendix "A" for a copy of the ACT Checklist. Use this checklist when ever performing ACT to ensure nothing is overlooked.

## **5. THE VENTING SYSTEM TEST**

This is the complete venting test that uses house depressurization measurements to determine the potential for backdrafting problems. The main advantage of this test is that it can predict venting problems that might occur under worst case conditions, even if such conditions are not present during the test. This test may require skills and equipment that the service technician is not familiar with.

### **5.1 Introduction**

The **Venting System Test** is designed to determine whether the combined action of a house's exhaust equipment could cause failure of the venting systems serving naturally-aspirated combustion appliances. The household exhaust systems considered by this test include kitchen and bathroom fans, dryer exhausts, fireplaces, vented combustion appliances, and all other devices which can exhaust air from the house.

When chimney venting failures occur, excessive amounts of combustion gases are spilled from the chimney into the living area of the house. This creates a potential health and safety hazard. The purpose of the **Venting System Test** is to help identify houses in which this hazard may exist so that appropriate action can be taken to avoid or eliminate it.

### **5.2 General Principles and Procedures**

The procedure can be used to test:

- (a) the impact of fans and fireplace operation on the chimney serving the furnace and water heater and
- (b) the impact of fans and furnace operation on the chimney serving a fireplace. In both cases, a manometer is used to determine if the maximum depressurization which can be produced by the combined operation of all household exhaust systems, exclusive of the test chimney itself, exceeds the maximum level that is safe for that type of chimney.

In addition, both the furnace and fireplace are operated at the maximum level of depressurization to determine if excessive combustion gas spillage can be observed.

The test requires 60 to 80 minutes to complete and requires no special expertise in heating systems. The test is suitable for all standard houses with naturally-aspirated heating equipment. This includes houses heated with gas, oil, or wood, and houses equipped with any variety of exhaust equipment or two-way fan systems.

No special certificate or licence for working with heating and ventilation equipment is necessary to do the test. However, the test does require careful attention to detail and must be conducted exactly according to the step-by-step procedure described in this manual. Consequently, some training and self-study will be required in order to adequately carry out the test procedure.

The purpose of the **Venting System Test** is to determine whether such pressure-induced spillage could occur in a particular chimney in a given home. The determination involves three parts as outlined below. (In the following description, the particular chimney under examination will be referred to as the "test" chimney.)

#### Worst-Case Depressurization Simulation and Measurement

To perform this test, an estimate of the minimum draft pressure which the test chimney will deliver is made using reference tables. The reference tables provide minimum draft values for various types of chimney. The minimum chimney draft pressure establishes an upper boundary for safe house depressurization. For this reason, the minimum draft pressure is referred to in this manual as the House Depressurization Limit or HDL for short.

The HDL approximates the draft pressure likely to be achieved in chimneys of the same type as the test chimney on calm spring days when outdoor temperatures are relatively mild and natural draft is weakest. In other words, the HDL can be regarded as the worst-case draft pressure for a given chimney configuration.

If the house's exhaust devices can produce house depressurization levels **GREATER** than the HDL, there is an unacceptable risk that chimney draft will be reversed and prolonged combustion gas spillage will take place. Consequently, the house cannot be considered "venting-safe" unless it is certain that house depressurization will **NEVER** exceed the HDL. For a listing of HDL Limits, see Table 5.1.

To determine if the house meets this safety requirement, the tradesman or technician must create "worst-case" venting conditions in the house. Worst-case venting conditions are those in which the house is as tight as possible (all doors and windows closed) and in which all exhaust devices, except the test chimney itself, are operated simultaneously.

The level of house depressurization created under these worst-case conditions is measured using a manometer. If the worst-case depressurization is **LESS** than the HDL, the house passes the test.

If the worst-case house depressurization **EQUALS** or **EXCEEDS** the HDL, the house fails the test. Remedial actions will have to be implemented until the house can pass the test. See Chapter 8 and Appendix B for information on remedial measures.

**Table 5.1**

**HOUSE DEPRESSURIZATION LIMITS (HDLs)**

<b>Appliance</b>	<b>Chimney Height to Closest Metre</b>	<b>H.D. Limit-Pascals Unlined Chimneys on Exterior Walls</b>	<b>H.D. Limit in Pascals Metal-Lined Insulated or Interior Chimneys</b>
Gas - Fired Furnace, Boiler, or Water Heater	4 or less	5	5
	5 - 6	5	5
	7 or more	5	5
Oil - Fired Furnace, Boiler or Water Heater	4 or less	5	5
	5 - 6	5	5
	7 or more	5	5
Fireplace (wood or gas)	NA	5	5
Airtight Wood-Stove or Fireplace	NA	10	10
Appliance with Retrofitted Induced Draft Fan	NA	10	15

**5.3 Tools and Time Requirements**

A **Venting System Test** requires about 60 to 80 minutes to complete. Time can be less for experienced test users, for tests done in simpler houses with fewer fans and chimneys, and for tests done in conjunction with air-tightness testing. Tests tend to be longer in houses with lots of venting systems, and especially in houses where problems are encountered due to high levels of house depressurization.

The **Venting System Test** requires three pieces of equipment: a pressure measuring apparatus, smoke pencil and a wood fire simulator. All this equipment will fit in a standard tool box. The cost of purchasing this equipment is approximately \$350. The cost of materials used for each test is about \$6 (a smoke pencil tube and some propane fuel).

Each piece of equipment is described in more detail below.

### Pressure Measuring Apparatus

This device must be capable of measuring pressure differences from 0 to at least 25 Pascals, with an accuracy of  $\pm 0.5$  Pascals. One common choice for the pressure measuring apparatus is an inclined, block manometer. Inclined manometers are relatively inexpensive gauges, and are very portable. A properly maintained manometer will not lose its accuracy with time, and does not need to be recalibrated.

Other types of pressure gauges can also be used, including electronic manometers and electronic pressure transducers. Magnahelic gauges are not sufficiently accurate for this type of test. Because manometers are the most commonly used pressure measuring apparatus, the remainder of this test will assume the tester is using a manometer.

A pressure tube 12 metres (39 feet) or longer should be fitted to the lower side (or high pressure port) of the manometer for use as an outdoor pressure tube (See Figure 5.1.). Since the manometer will be set up in the furnace room of the house (if there is one) or the basement, the tube must be long enough to reach an opening in the outside wall and still reach beyond the house at least 8 metres (26 feet). A good choice is polypropylene tubing, with an inside diameter of 4.76 mm (3/16 inches) and an outside diameter of 7.94 mm (5/16 inches). Some ingenuity may be needed to find the best location to route the tube out of the house, for example: a mail box, a milk box or through the corner of an exterior door (if it appears that the door weather-stripping will not pinch the tubing), are suitable locations.

A method of reducing the effect of wind on windy days is necessary. Inserting the end of the outdoor pressure tube into a piece of foam rubber (like that used in seat cushions) helps reduce the fluctuations in the pressure readings due to wind gusts and is often necessary for accurate testing.

### Wood Fire Simulators

A wood fire simulator is used to simulate a fire in a fireplace. The simulation is necessary so that the exhaust effect of fireplaces can be included in the "worst-case" depressurization measurement.

Without a wood fire simulator, the only alternative would be to use paper and wood, which would create additional clean-up work for the tester, and possible annoyance for the householder if wood smoke were to spill indoors during the test.

A wood fire simulator is a portable heater. A two-burner camping stove meets the requirements for a wood fire simulator and is recommended for this purpose.

**FIGURE 5.1 Manometer and Tubing Set**

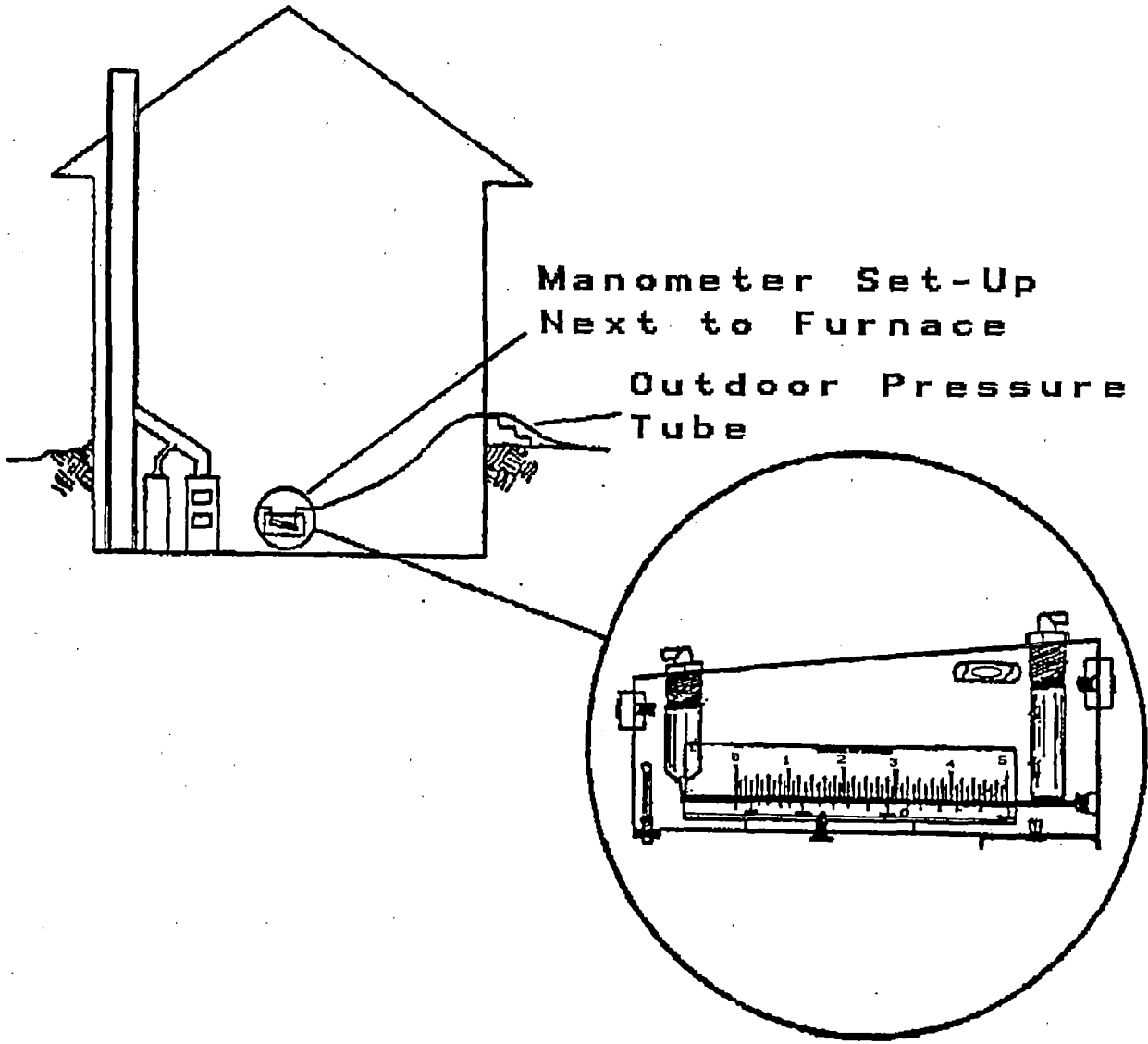

**FIGURE 5.2 Venting System Test**

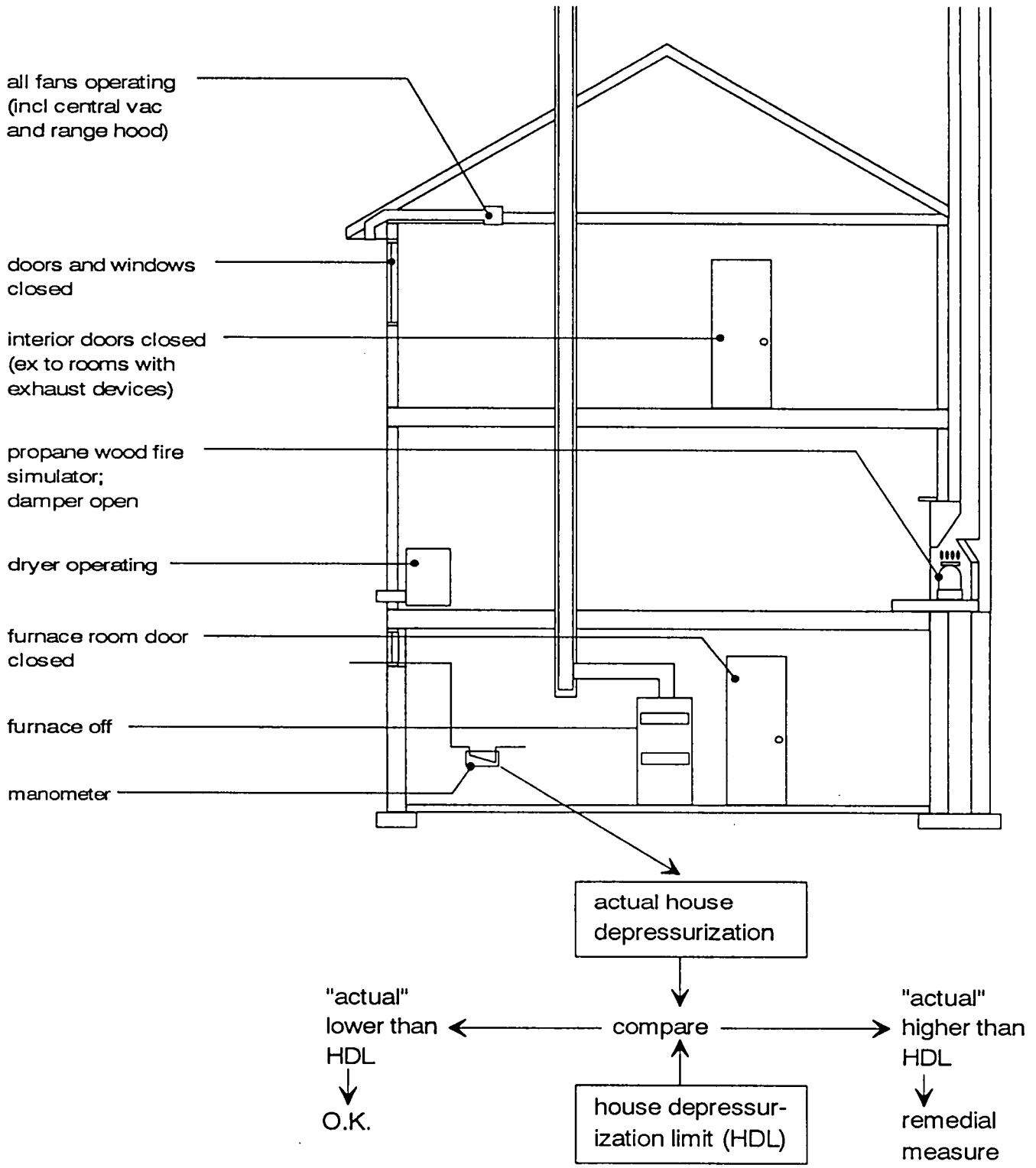



Single burner stoves may not produce enough heat in the smoke chamber of the fire box. A two burner propane stove is recommended. Two stoves are also useful in houses with two fireplaces. In the rest of this manual, we refer to the wood fire simulator as a propane stove.

### Smoke Pencil

In order to conduct the test, a "smoke pencil", also referred to as an "air current tube" or a "draft detector", is required. They are available from safety supply stores. A typical smoke pencil is a glass tube, about the same size as a pencil, which is partially filled with a chemical. To use the smoke pencil, both ends of the sealed tube are snapped off. A rubber ball with a small hole fits over one end. Place your thumb over the hole in the bulb and squeeze it, this forces air through the tube, and smoke is produced. Let your thumb off the hole in the bulb and let it fill up with air and repeat if more smoke is required. The path the smoke takes will enable the technician to determine whether or not spillage is occurring. Further details concerning where to use the smoke pencil are given in the next section. Immediately after finishing with the smoke pencil, cover the ends with the small rubber caps provided in the kit. This will save the smoke pencil for additional tests.

Caution: Do not squirt the smoke directly at electronic components or at fabrics or furniture because the smoke of some air current detectors may be corrosive in high concentrations. If the glass tube containing the chemical breaks when attempting to open it, the contents may stain the surface that they fall upon.

## **5.4 THE STEP-BY-STEP TEST**

The **Venting System Test** (See Figure 5.2.) is conducted in three stages: **PREPARATION**, **TESTING**, and **CLEAN-UP**. Each of these stages is described below. The descriptions will help you become familiar with what is to be done and why. You won't actually follow these descriptions when conducting a **Venting System Test** in a house. Instead, you will use a **CHECKLIST** to conduct the **Venting System Test** and a **REPORT FORM** to record the results. Both the Checklist and the Report Form are presented in Appendix A.

The Checklist is a short convenient outline of how to do the **Venting System Test**. It is designed to be checked off step-by-step as you conduct the test. This will help you to avoid mistakes and omissions, since the procedure can get complicated in some houses. The Checklist also helps to avoid return visits to houses because you forgot to turn off a furnace fan, pack up your propane stove, or complete some other important steps. For these reasons, it is recommended that you **NEVER CONDUCT A VENTING SYSTEM TEST WITHOUT USING THE CHECKLIST**.

The Checklist should be easy to follow once you have read through the more detailed descriptions provided below.

## **Detailed Description on the Venting System Test**

### **STAGE 1 - PREPARATION**

1. Make sure the information is filled out completely on the forms at the time you do the test.
2. Record the approximate wind speed (calm, light, moderate or strong), wind direction, and outdoor temperature on the report form. This information is just for reference and is not used in any calculations, so approximations are adequate.
3. Switch off all the exhaust devices in the house, including the furnace and exhaust fans like range hoods, clothes dryers, and air conditioners.
4. Turn off furnace by lowering the house thermostat setting. There is no need to extinguish pilot lights.
5. If water heaters are not operating at the moment and no one is using hot water, it is probable that they will stay off. You can usually leave water heaters as they are, and ask the occupants not to use hot water until the test is complete.
6. Close the doors, windows, chimney dampers, and other intentional openings in the house. The object is to make the house as tight as it would be under normal winter operating conditions to simulate the conditions, under which the depressurization induced by the operation of exhaust devices would be at a maximum. As a general rule, make the house as tight as possible without doing things an occupant wouldn't do, like taping over an air inlet or plugging a chimney.
7. While you are moving through the house closing doors, windows, and other openings, also close-up interior doorways in the house to all rooms except rooms that contain either a chimney or an exhaust device like a bathroom or kitchen fan. The rooms without chimneys and exhaust devices do not contribute to house depressurization and are sometimes referred to as passive rooms. Bedrooms, for example, are usually passive rooms. The doorways into these passive rooms will remain shut throughout the test.
8. Install a propane stove (the wood fire simulator) in each fireplace, but do not light it.
9. Make sure each fireplace is completely closed up. This includes closing the damper, air supply, and fireplace doors where applicable.

10. Set-up the pressure gauge (manometer) in the same room as the heating appliance and/or water heater. Level the manometer. (This will require several minutes for the manometer to become warm and stable, so that it can be properly zeroed.)
11. Attach the 12 M+ (39 foot) long exterior pressure tubing to the low end (high pressure side) of the manometer. Extend the tubing outdoors through a suitable location, such as a mail slot, keyhole, or door corner. The easiest place to use as an exit for the tubing is usually a doorway that is weather stripped. The door must be pulled shut to ensure maximum tightness but it should be possible to squeeze the tubing into the corner with the biggest gap without causing the tube to be pinched too tightly by the closed door. If there is any doubt, disconnect the tubing and suck on the end to ensure that some air movement is still possible. The exterior tubing should terminate at least 8 meters (26 feet) away from the house.
12. Zero the manometer according to the manufacturer's instructions. Observe the pressure reading on the scale for about a minute, and record the maximum pressure fluctuation over this period. Major fluctuations in pressure readings are usually a result of wind gusting.
13. If the fluctuations exceed 0.5 Pascals (.002 IWC), the wind is likely to affect the results of the test, and you will need to use your pressure averaging system (piece of foam cushion material). Go back outside the house and insert the exterior end of the tubing into the piece of foam cushion material.
14. If the pressure fluctuations continue to exceed 0.5 Pascals after attaching the averaging system, further testing is not recommended since it is possible that the pressure fluctuations may lead to inaccurate or misleading test results.

## STAGE 2 - TEST PROCEDURES

1. You should have closed the door to the furnace room, if there is a furnace room. Close the door to the basement if the furnace is located in the basement. Then operate the furnace circulating blower. If no manual furnace blower switch can be found, you will have to leave out this step of the test, unless you are a licensed gas fitter or oil burner service mechanic and can adjust the fan switch on-off levers to a low temperature to activate the blower. Naturally, you will also skip this step if the house is heated with a hot water boiler, instead of a furnace.

Most furnaces have a manual switch which allows operation of the blower even when the burner is not firing. This switch is often called the summer-switch. It is sometimes located at the side of the furnace. On other furnaces it is a push button or metal switch located on a hand-sized fan control box behind the front cover of the furnace. If the furnace has a two-speed fan, operate the fan at the lower speed.

After operating the furnace blower, read the manometer, and record the pressure on the Report Form. If the pressure you record exceeds zero, the furnace room is depressurized, and the furnace blower should remain operating for the remainder of the test. If, on the other hand, the recorded pressure is less than or equal to zero, the blower should be shut off.

2. Open the basement and furnace room doors.

3. Exhaust fans. Turn on all the exhaust fans in the house (except fans in combustion venting systems, such as "draft inducers"). All the exhaust fans should be operating at their highest speed, and at the same time.

To make sure that the fans are blowing as much as possible, remove lint from clothes dryer lint screens prior to operation and remove the grease filter from the kitchen range hood fan if the filter is plugged or dirty. To operate a whole house vacuum, insert the vacuum hose in the wall socket. If bathroom fans have timer switches, use tape to ensure that the fans remain on for the period of the test. Recirculating fans that do not exhaust air from the dwelling do not need to be operated. If there is any doubt as to whether the fan is an exhaust fan or a recirculating fan, leave the fan operating.

***Read the manometer and record the pressure on the Report Form. Leave all exhaust devices operating.***

### Wood Fire Simulation

If the house has a fireplace, now is the time to use your propane stove. If the house has two fireplaces, begin with the fireplace which appears to be used most frequently, and repeat this section of the test for the second fireplace.

4. Before operating the propane stove, open the chimney damper, and open any combustion air supply to the fireplace.

5. Also, temporarily open a nearby door or window to the outdoors. Opening a door or window is necessary in some houses to get the fireplace operating properly while all exhaust devices are in operation.

6. Light the propane stove/wood fire simulator and adjust it to its highest rate of burn.

### Furnace Spillage Check

All the exhaust fans and fireplaces in the house should now be operating at maximum, unless one

or more fireplaces had to be shut off and closed up due to excess spillage. The next step is to start up the furnace and check for spillage through the dilution air inlet of the furnace.

7. If a window was open close it.

8. The furnace is started by adjusting the household thermostat to a high temperature. But first make sure that your smoke pencil is ready, and that you have a watch or time piece for recording the number of seconds of spillage. The best procedure is to have the householder or somebody else turn the thermostat up, so you can be standing next to the furnace. However, a few seconds delay in getting from the house thermostat to the furnace will not be a problem.

9. Once the furnace is started, squirt smoke all around the dilution air inlet, and especially along the upper edge (See Figure 5.3.). If hot gases are spilling out of the dilution air inlet, and into the house, record the duration of the spillage. Some start-up spillage is a normal event, however, if the duration of spillage exceeds 30 seconds, there is likely a problem with the venting systems. If the spillage duration exceeds 3 minutes, you can stop recording, since this is sufficient evidence of a serious spillage problem.

10. If there is no spillage at the dilution air inlet, use the smoke pencil to test for spillage along the vent pipe, the dilution air inlet of the domestic hot water heater, if connected to the same chimney/vent and at the junction between the furnace vent, the water heater flue and the chimney.

11. If spillage has occurred for longer than 3 minutes, you need to determine if this spillage is affected by the house depressurization, or is a result of some other problem such as weak chimney draft. This is an easy matter, since by opening a window or door to the outside, with an open area of at least  $.1 \text{ M}^2$  ( $1 \text{ ft}^2$ ), you can eliminate the house depressurization and then see whether or not the spillage continues. If the spillage continues, the cause of spillage may be a poorly performing chimney. Leave the furnace operating and open a nearby door or window to the outside. Checking again with the smoke pencil will show you whether the spillage is still occurring. If it is still occurring, house depressurization is unlikely to be the cause of the observed spillage and the "Chimney Performance Test" described in Chapter 6, should be performed. If the spillage stops, the problem is probably house depressurization.

12. If spillage was observed and exceeded 30 seconds, but eventually disappeared when proper chimney draft was established, you will have to repeat the furnace test with a door or window open to the outdoors. Shut off the furnace with the house thermostat, open the "door or window to the outdoors, prepare your smoke pencil and watch, let the furnace cool for a few minutes, and then turn the furnace on and time spillage once again. If spillage still occurs, house depressurization is not the cause and the "Chimney Performance Test" described in Chapter 6, should be performed.

**FIGURE 5.3 Checking for Spillage with a Smoke Pencil**

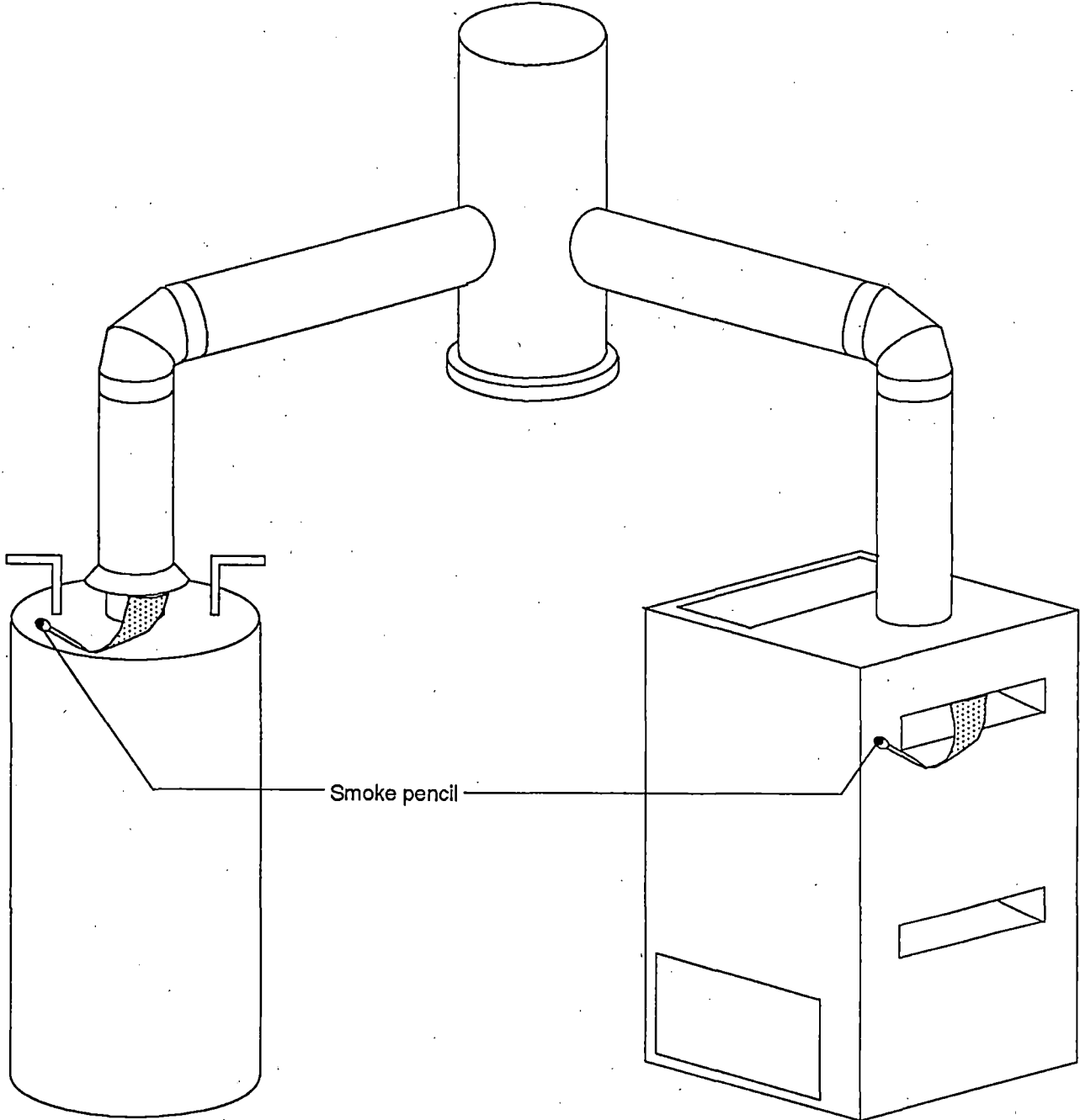

Gas Fired Water Heater

Gas Fired Furnace

13. Record the results of your furnace spillage check on the Report Form. Ensure the door or window you opened to check the cause of spillage is closed again.

#### Water Heater Spillage Check

14. If the hot water heater is non-electric, you will need to do a water heater spillage check. With the furnace off and the chimney cool, and fireplaces and exhaust fans still operating as they were for the Furnace Spillage Check, operate the water heater and check for spillage in a way similar to that used for the furnace (repeat steps 11 and 12). To operate the hot water heater, run hot water from a tap in a nearby sink for several minutes.

15. Once the water heater begins to operate, check for spillage with the smoke pencil at the dilution air inlet of the water heater. If spillage is occurring for longer than 30 seconds, open a nearby window or door and check for spillage again. If spillage still occurs, house depressurization is not the cause.

16. Check for spillage along the vent pipe and at the dilution air intake of the furnace/boiler.

17. Record the duration and severity of any spillage from the water heater on the Report Form, and note the effect of opening an outside door or window.

#### Fireplace Depressurization Level

18. Fans and Furnace Exhaust Only: If the house has fireplaces with propane stoves still operating, shut off the stoves and close up the fireplaces (damper, combustion air doors).

19. With the exhaust fans still operating, turn on the furnace and water heater, read the manometer and record the pressure on the Report Form. This pressure is the worst house depressurization that can be experienced by the fireplaces.

#### **STAGE 3 - CLEAN-UP:**

Return the house to its normal operating condition.

1. Reset the house thermostat.
2. Turn off the hot water tap.
3. Shut off the furnace blower switch.

4. Shut off all the exhaust fans. Remove the tape on any timer switches, and replace filters so that the fans are left in the same position you found them.
5. Return all the doors and windows in the house to their original position.
6. Pack up your test apparatus. Roll up the pressure tubing, pack up the manometer.
7. Pick up the propane stoves (wood fire simulators), and pack up the smoke pencils.

**STAGE 4 - REPORTING:**

Record the need for any follow-up action on the Report Form. Let the householder know immediately about any urgent problems.

**See Appendix A for a copy of the Venting System Checklist and Report Form.**



## **6. THE CHIMNEY PERFORMANCE TEST**

### **6.1 Introduction**

The **Chimney Performance Test** is designed to determine whether a chimney might be performing especially poorly. Some chimneys suffer from poor draft problems and spillage because of major design flaws (e.g. too many restrictions), blockage, cracks and large leakage areas. It is not always possible to recognize these types of problems just by looking at a chimney. In cases where a chimney is suspected of poor performance, the best approach is to test the chimney and ensure that it performs at least as well as other chimneys of similar design.

### **6.2 General Principles and Procedures**

The **Chimney Performance Test** is especially useful in helping to diagnose spillage problems identified during the Venting System Test. For example, if a chimney is found to spill even though the house is not depressurized to a level below the House Depressurization Limit for its chimney type, the problem may be an exceptionally weak chimney. House Depressurization Limits (HDL's) are for chimneys in relatively good condition.

The Safety Inspection or ACT may reveal unusual constrictions or leakage and thus indicate a need for testing chimney performance.

The **Chimney Performance Test** is a very simple procedure. It consists of two measurements:

- \* chimney temperature
- \* chimney static pressure

Because chimney draft is developed by high temperatures, the first step in evaluating chimney performance is to measure chimney temperature. Excessively low chimney temperatures will, of course, develop inadequate chimney draft. Also, if temperatures are too low at the chimney bottom, the possibility exists that condensation problems will occur at the chimney top.

Exterior chimneys require higher breech temperatures than interior chimneys because of the extra heat losses through the chimney sides. An exterior chimney is a chimney with one or more sides exposed to outdoor temperatures, from top to bottom.

Higher chimney gas temperatures are certain to improve the draft and reduce the amount of condensation. However, if temperatures are too high, the temperature of nearby combustibles may exceed fire safety limits. Also, temperatures above about 370°C (700°F) can damage some

venting systems by destroying the galvanized surfaces of steel vent connectors. Another additional consideration is that, all other things being equal, higher stack temperatures usually mean the heating system is less efficient than it would be if the stack temperature was lower. Increasing the air flow through a furnace increases its efficiency by pulling more heat from the flue gases resulting in lower flue gas temperatures. Increasing the firing rate of an oil furnace will increase flue gas temperature at the cost of a loss in efficiency. It is quite obvious that some measures to increase flue gas temperature to improve combustion venting and chimney performance should only be used as a last resort and then only after insulating the vent connector to increase the temperature of the flue gases entering the base of the chimney (often that is all that is necessary).

The gas temperature is measured after the system has warmed up (that is, under steady-state conditions). The temperature must be high enough to avoid problems from condensation and poor draft, but not so high as to be a potential fire hazard, or to damage chimney materials.

Although chimney temperatures tend to get warmer and warmer the longer an appliance operates, temperatures may start to level off after 3 to 4 minutes of operation. Most thermometers require a minute or so to reach these high temperatures. Consequently, the measurements of chimney temperature (and draft) are taken after at least 5 minutes of appliance operation.

The static pressure is also measured after the system has warmed up. The house is opened-up, so that house depressurization can not interfere with chimney performance. Although static pressure is not a measurement of the total chimney draft, it does provide a rough indication of the total chimney draft. Total draft includes the velocity pressure as well.

If the static pressure is very low, it is probable that total draft is also low, and that something is wrong with the chimney itself. Both restrictions and excess leakage in the chimney will have the effect of lowering the chimney draft and increasing potential for spillage. When chimney draft is low, because of restrictions or leakage, the chimney is more easily influenced by wind pressures and house pressures.

The static pressure measurement is simply a measurement of the pressure difference across the metal wall of the smoke pipe/vent connector. To complete this measurement, a metal probe is inserted through an appropriately sized hole in the smoke pipe/vent connector and attached with tubing to a pressure gauge. Pressure inside the vent will be lower than the house. As gases move up the chimney, the pressure difference - or draft - is converted into energy of motion (velocity pressure). Consequently, the static pressure is only a partial measurement of chimney draft.

## **6.3 TOOLS AND TIME REQUIREMENTS**

### **Thermometer**

The scale of the thermometer must cover a temperature range of 100°C to 350°C. The thermometer should have a probe 3 to 6 inches (75 mm to 150 mm) in length, suitable for inserting through a 1/4 inch (5 mm) hole. Dial type thermometers are convenient to insert and leave in place, and are easy to read.

### **Pressure Gauge**

In electronic draft gauge or an inclined manometer is needed with a scale in .004 inch (1 Pascal) divisions, and a range from 0 to .2 inches W.C. (0 to 50 Pascals) is required. (Most of the small, hand-held, mechanical gauges are not sufficiently accurate for Chimney Performance Testing.)

### **Pressure Tubing**

A short piece of flexible tubing is required to connect the pressure gauge to the vent connector. To avoid melting plastic or rubber tubing, use a short metal tube for inserting into the vent. Suppliers of pressure gauges will also supply specially designed probes for measuring static pressure, which may include a heat resistant rubber gasket, and a clip for holding the probe in place.

### **Time Requirements**

Measurement of chimney temperature and draft requires between 5 and 10 minutes. The pressure gauge and tubing can be set-up while the chimney is warming up.

## **6.4 The Step-by-Step Test**

For Furnaces, Boilers and Domestic Hot Water Heaters

1. **Gas Appliances:** Tape the draft hood closed or block it off with a piece of foam plastic insert the thermometer through a 1/4 inch hole (use a drill or punch and hammer) located near the base of the chimney on a straight section of pipe. Later you will measure the draft in this same location with the draft hood open and operating normally. (See Figures 6.3 and 6.4)  
  
**Oil Appliances:** Insert a thermometer into a 1/4" hole on a straight section of pipe near the base of the chimney with the barometric damper held closed. (See Figures 6.1 & 6.2)
2. Partially open a nearby door or window to the outside.

3. Begin operation of the appliance. If the appliance is a furnace (or boiler), turn up the house thermostat. If it is a hot water heater, turn on a hot water tap.
4. Once the appliance begins to operate, begin timing (see Figures 6.1 and 6.3).
5. Set up the manometer on a level surface, close to the 1/4 inch (5 mm) hole. Open the pressure ports, connect the tubing, and zero the gauge.
6. After 5 minutes of appliance operation, record the temperature of the chimney gases, and remove the thermometer.
7. Insert the static pressure probe in the 1/4 inch (5 mm) hole (see Figure 6.2 and 6.4). (The probe should not penetrate into the pipe more than 1/8th inch (2 or 3 mm).
8. Record the static pressure, and remove the pressure probe.
9. Shut off the appliance by resetting the house thermostat (or turning off the hot water tap).
10. Close the door or window to the outside.
11. Pack-up the test equipment.
12. Evaluate the adequacy of chimney gas temperatures using Table 6.1.
13. Evaluate the adequacy of static pressure by comparing the static pressure with the House Depressurization Limit (HDL) for the system being tested. Static pressure should be at least 1 Pascal (.004 IWC) above the HDL. Refer to Table 6.2 for HDL's.

The **Chimney Performance Test** is Summarized in Figures 6.1, 6.2, 6.3 and 6.4.

**FIGURE 6.1 Oil Chimney Performance Test - Temperature**

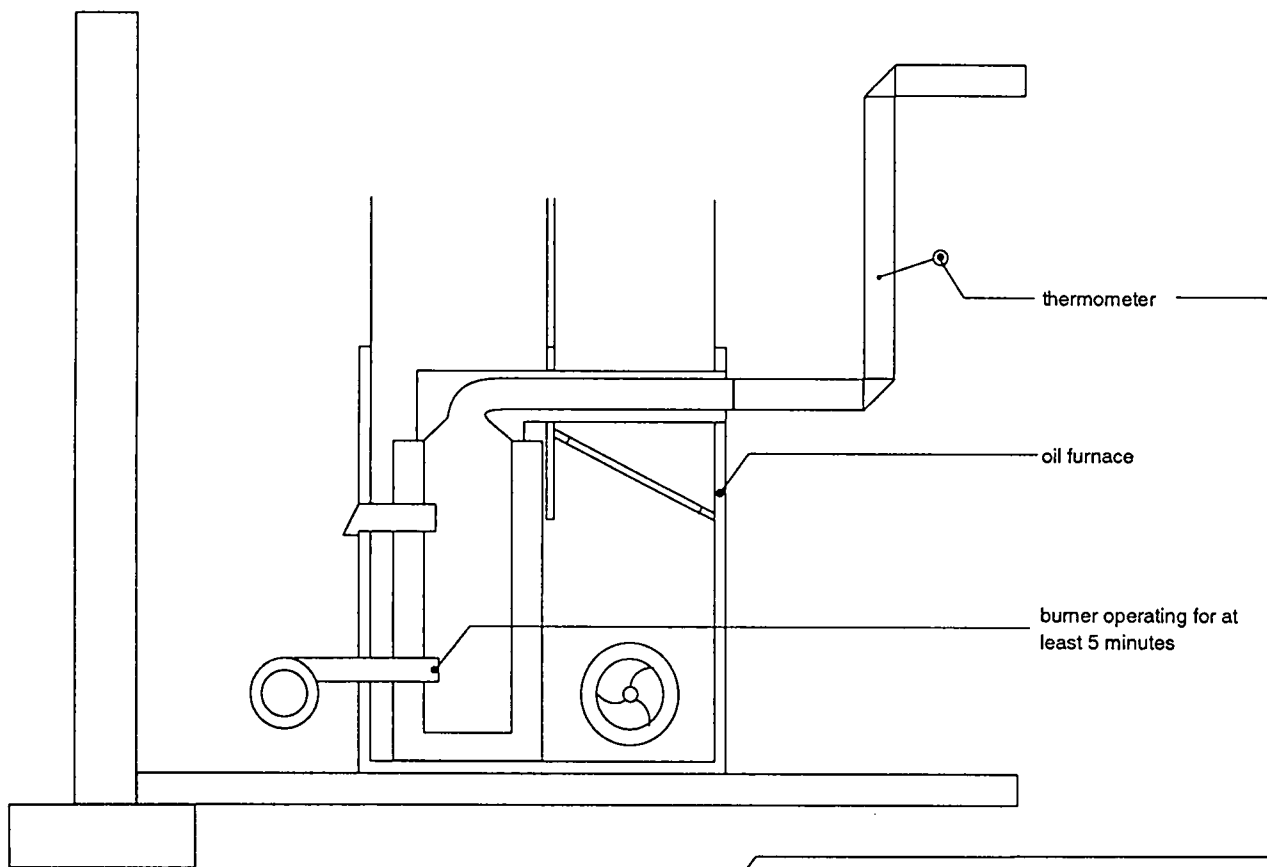

```
graph TD; T[temperature] --> C[compare]; C --> IL[inside limits]; C --> OL[outside limits]; IL --> OK[O.K.]; OL --> RM[remedial measures]; TL[temperature limits table 6.1] --> C;
```

The flowchart details the decision-making process based on the measured temperature. The measured temperature is compared against the limits specified in table 6.1. If the temperature is within the specified limits, the system is considered O.K. If the temperature is outside the limits, remedial measures must be taken.

**FIGURE 6.2 Oil Chimney Performance Test - Pressure**

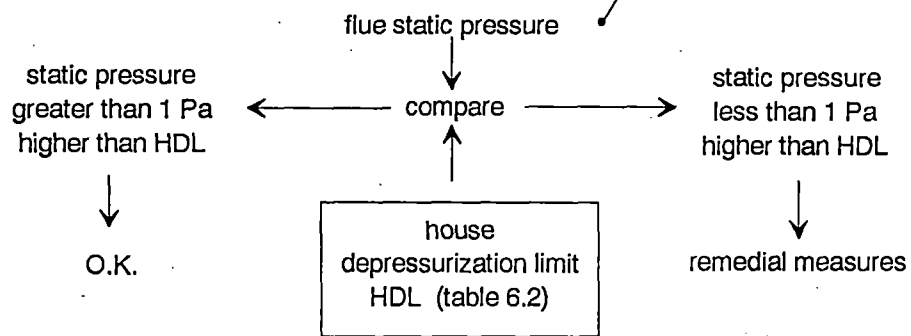
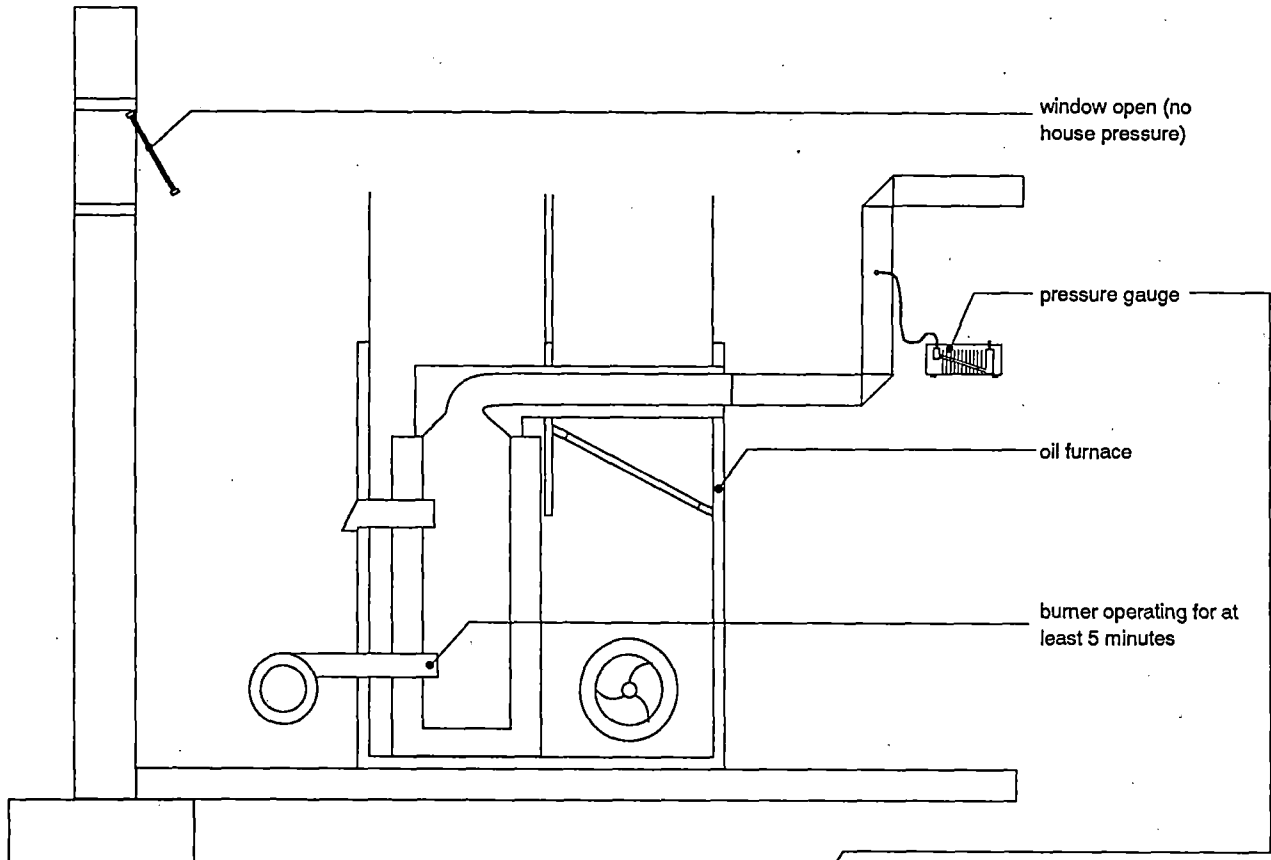

**FIGURE 6.3 Gas Chimney Performance Test - Temperature**

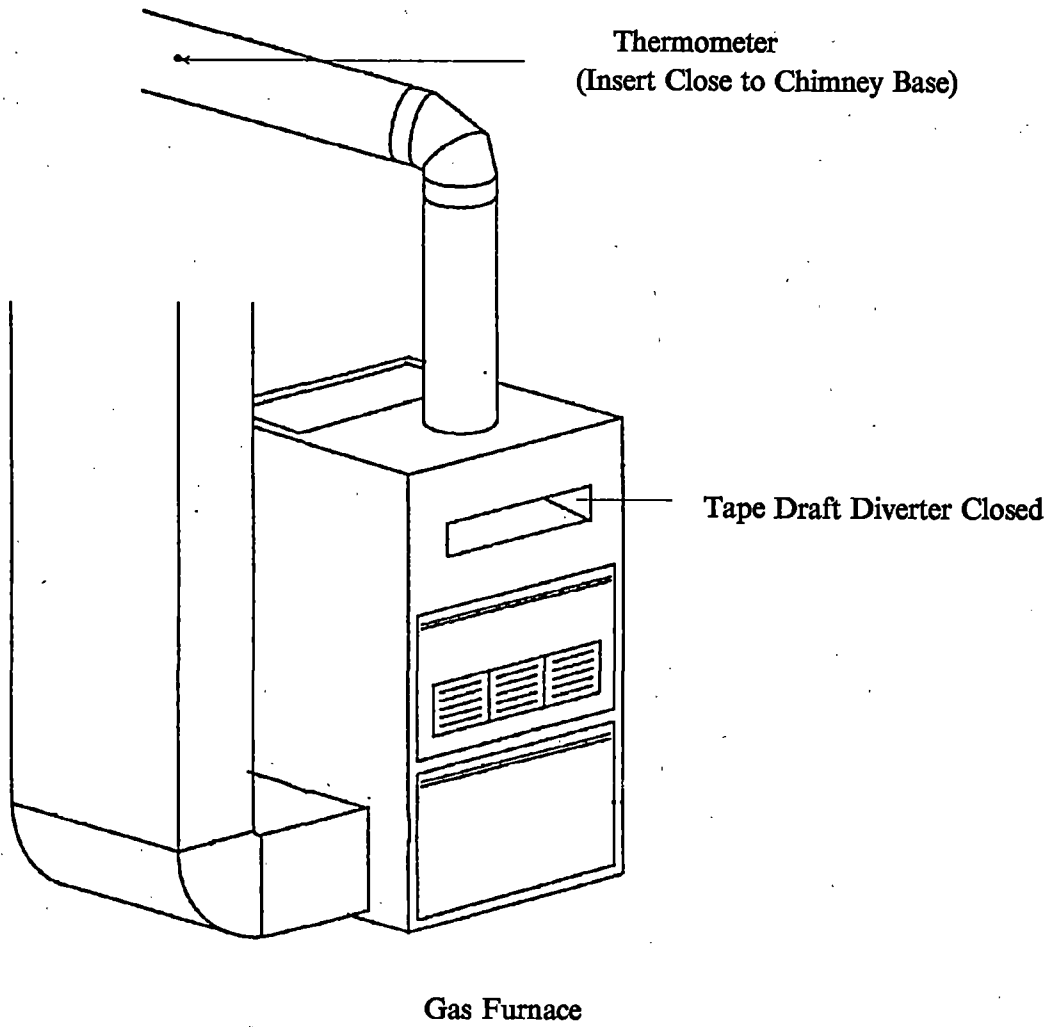

**FIGURE 6.4 Gas Chimney Performance Test - Pressure**

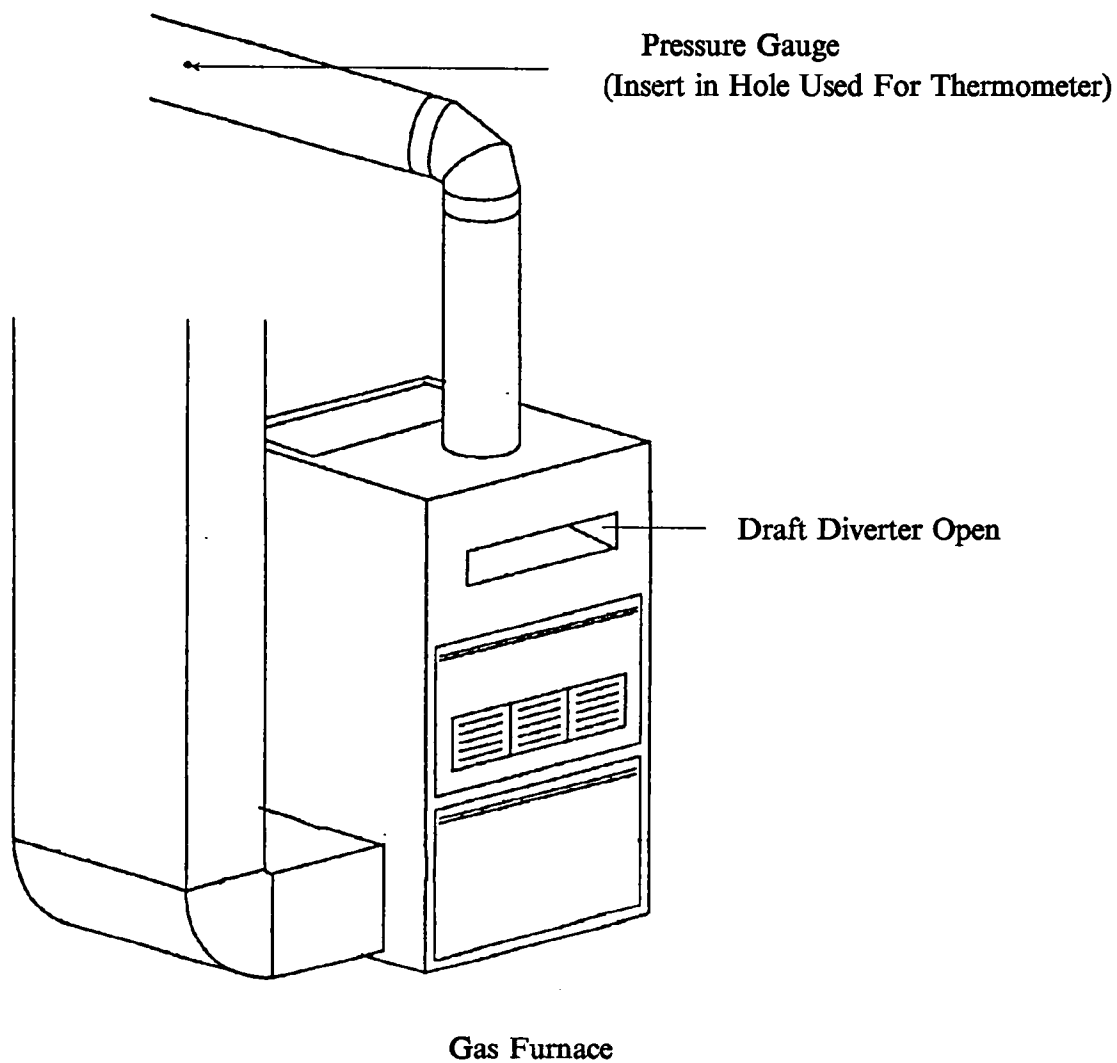



**Table 6.1**

**TEMPERATURE GUIDELINES FOR PRODUCTS OF COMBUSTION**

Chimney Type	Chimney Height (to nearest metre)*	Minimum Temperature** °C (°F)		Maximum Temperature °C (°F)	
		GAS	OIL	GAS	OIL
Un-insulated Exterior Masonry	4 or less	210 (410)	230 (446)	300 (572)	430 (806)
	5, 6	230 (446)	250 (482)	300 (572)	430 (806)
	7 or more	270 (518)	290 (554)	300 (572)	430 (806)
Other Types	6 or less	210 (410)	225 (437)	300 (572)	430 (806)
	7 or more	230 (446)	250 (482)	300 (572)	430 (806)

\* Vertical distance from chimney to cap.

\*\* Values are approximated, measured without the addition of dilution air from either a draft hood, diverter or barometric damper, and are intended to avoid condensation occurrence at chimney top after 5 minutes of appliance operation, with an outdoor temperature of -10°C (14°F) and a dew point of 58°C (136°F). The minimum temperatures shown do not have to be achieved if chimney performance (adequate draft is established) becomes satisfactory at a lower temperature. Maximum temperatures shown reflect safety concerns, for the purpose of energy efficiency, normal operating maximum flue gas temperatures should be much lower.

**Table 6.2**

**HOUSE DEPRESSURIZATION LIMITS (HDLs)**

Appliance	Chimney to Closest metre	H.D. Limit in Pascals	
		Unlined Chimneys on Exterior Walls	Metal-Lined Insulated or Interior Chimneys
Gas-Fired Furnace, Boiler or Water Heater	4 or less	5	5
	5,6	5	5
	7 or more	5	7
Oil-Fired Furnace or Water Heater	4 or less	5	5
	5,6	5	5
	7 or more	5	5
Fireplace (wood or gas)	N/A	5	5
Air-Tight Wood Stove or Fireplace	N/A	10	10
Appliances with Retrofitted Induced Draft Fans	N/A	10	15

1 Pascal = .004 inches of water column

## **7. HEAT EXCHANGER LEAKAGE TEST**

### **7.1 Introduction**

Heat exchanger leaks or cracks will allow undesirable gasses to be injected into the residence, either through the air distribution system or out the draft control when the air circulation blower is operating. A **Heat Exchanger Leakage Test** will not always be required as part of a normal service or maintenance visit or the ACT procedure, however, the heat exchanger should be tested, with the owner's permission, if one or more of the following symptoms exist:

- \* The homeowner reports odours during furnace operation or at start up.
- \* An O<sub>2</sub> or CO<sub>2</sub> test indicates that excessive dilution of the products of combustion is occurring after the air circulation blower starts operation.
- \* Any other reasonable suspicion - excessive moisture, history of furnace type and customer complaints of winter sickness.
- \* There are sooty or oily deposits at duct joints or at the supply outlets.

Traditional techniques for testing cracked or burnt-out heat exchangers include:

- \* smoke bomb or sulphur test;
- \* oil of wintergreen;
- \* flashlights; and;
- \* salt vapour as a tracer gas.

Most of these techniques, however, are not desirable because they are unreliable and they require the house to be "aired-out" following the test, if excessive spillage occurs. Two newer techniques that have been tested with success are:

- \* Using a smoke pencil to determine if the forced air circulating fan pressurizes the heat exchanger combustion zone; and

- \* Using an electronic flue gas analyzer to check for CO<sub>2</sub> within the warm distribution system. This test is performed without the air circulation fan operating.

The test for CO<sub>2</sub> in the warm air bonnet may not produce accurate results depending on the size and position of any cracks on the heat exchanger. A warm exchanger may cause convection and pull in larger quantities of air from the return system. This air can dilute samples below levels that can be detected by normal field test instruments.

The smoke pencil test procedure is to determine if there is a defective exchanger. Additional testing is required to determine the exact location of the defect for homeowner observation when required.

**Note: This test should only be conducted by a licensed gas fitter or oil burner service mechanic, which ever is appropriate.**

The smoke pencil test is recommended because:

- \* It is a proven procedure;
- \* it is non-offending to the homeowner (i.e. no odours);
- \* it is quick and easy to perform; and
- \* it requires no new equipment.

## **7.2 Tools and Time Requirements**

Few tools are required for this test:

- \* a smoke pencil
- \* a role of duct tape
- \* a flashlight and in the case of gas furnaces,
- \* a piece of foam large enough to block off the burner area from the room.

## **7.3 The Step-by-Step Test**

To conduct a **Heat Exchanger Leakage Test**, follow the steps below using the report form provided. Check off each of the steps on the checklist provided on the report form. Use the report form to record all your results, observations and recommendations.

### **7.3.1. Initial Preparations**

Check for a blower switch, and make sure you have the tools and equipment you need.

If the furnace does not have a manual switch (summer switch) for operating the circulating blower, lower the blower on/off temperature levers as far as they will go. This will activate the blower. Be sure to return them to their original setting (or, ideally 120°F on and 90°F off) after the test has been completed.

### 7.3.2. Thermostats

The leakage test requires a cool furnace. In order to give the furnace time to cool and to make sure it doesn't operate during the test, turn down the house thermostat. Lock the household thermostat in its position by using a piece of tape across the thermostat. This tape will prevent operation of the thermostat by the householder during the test. It will also ensure that the householder does not use the thermostat in the event that you fail to reset and unseal the furnace.

### 7.3.3. Pilot Light

Blow out the pilot light if testing a gas furnace. The reason for blowing out the pilot, rather than just turning off the valve, is to ensure that safety controls on the furnace are operating properly. After blowing out the pilot light, the thermocouple next to the pilot will cool and eventually shut off the gas valve. This process can take up to three minutes. It is usually possible to hear when the valve is turned off because the gas hissing will stop and a click will occur in the main gas valve. Be sure not to light a flame near the furnace during this period. If a thermocouple fails to shut off the gas valve after three minutes, it must be replaced. The main gas valve can be manually shut off under such circumstances, and you can then proceed with the test. (The procedures described in 7.3.3 and 7.3.4 must only be done by a licensed gas fitter.)

### 7.3.4. Exit Ports of the Combustion Chamber

On a gas furnace, place a piece of foam rubber over the front of the burner area to prevent air escaping into the room from this opening, if a leaky heat exchanger is pressurizing this area. The idea is to have any leakage that may be occurring pressurize the passage for the combustion products and cause an air current out of the exit port(s). (See Figure 7.1)

On an oil furnace, disconnect the vent pipe and tape a piece of foil across the flue collar of the furnace. (See Figure 7.2)

**FIGURE 7.1 Heat Exchanger Leakage Test- Gas**

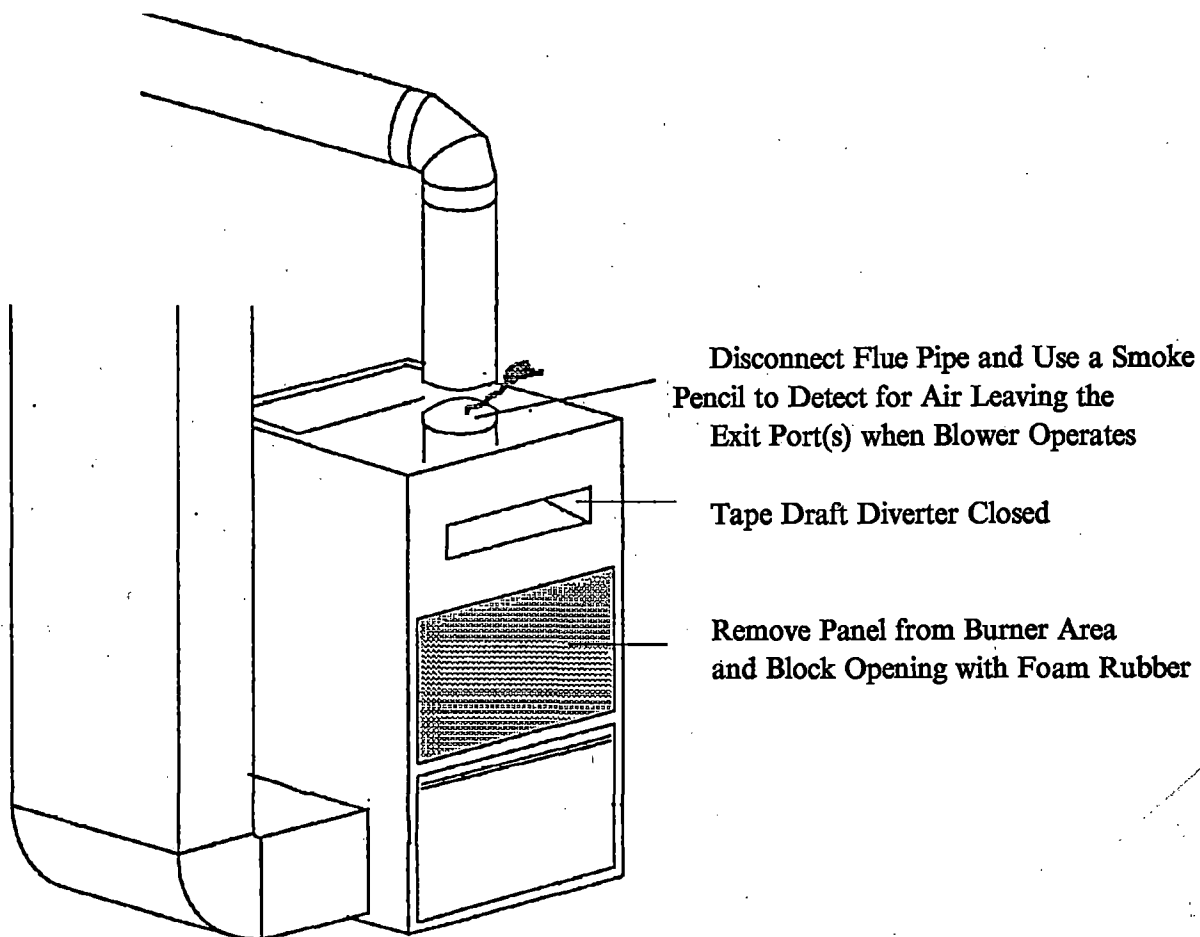

**Gas Furnace**

### 7.3.5. Precheck for Air Movement

Using the smoke pencil, gently squeeze smoke into and around the remaining opening into the combustion chamber.

On a gas furnace, squeeze smoke where the exit ports enter the draft hood.

On an oil furnace, squeeze smoke around and into the inspection port. Observe the air movements that are occurring.

### 7.3.6. Circulating Blower

After switching on the circulating blower, squeeze smoke into and around the combustion chamber. If a steady movement of smoke out of the combustion chamber is observed that was not observed in Step Five, there is definitely a leak in the heat exchanger.

Detecting leaks this way with an oil furnace is easy, since the inspection port is a small opening that creates a high velocity air stream.

On a gas furnace, squeeze smoke where the exit ports enter the draft hood. If the smoke is blown away from the ports, the heat exchanger is leaking and appropriate action should be taken.

Note your observations on the Report Form.

### 7.3.7. Clean-up

Shut off the blower, and unseal the combustion chamber. **IT IS VERY IMPORTANT TO REMEMBER TO UNSEAL THE COMBUSTION CHAMBER.**

Relight the pilot light (gas furnaces only).

Remove the tape from the house thermostat and use it to turn on the furnace.

**If an oil furnace was tested, be sure to unseal the flue collar and reconnect the vent/smoke pipe.**

Observe the furnace operation, and make sure no spillage is occurring. If spillage is evident, you will have to inform the householder, and you may want to investigate other causes using other tests in this manual.

Reset the house thermostat to its original position.

Clean-up any tools and materials.

**See Appendix A for a copy of the Heat Exchanger Leakage Test Checklist.**

**The Heat Exchanger Leakage Test is summarized in Figures 7.1 and 7.2.**

**FIGURE 7.2 Heat Exchanger Leak Test - Oil**

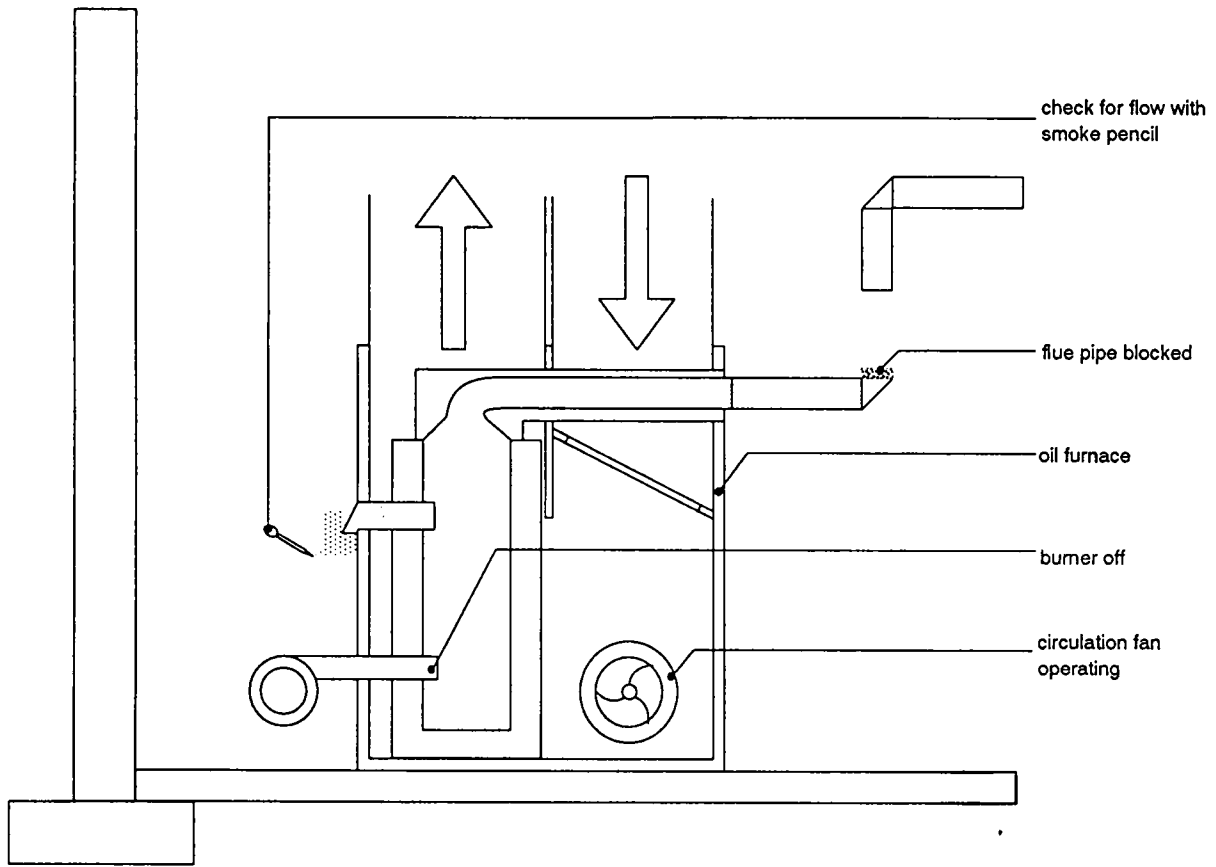



## **8. REMEDIAL MEASURES**

### **8.1 Introduction**

When the **Venting Systems Test** reveals unsafe levels of house depressurization, it will be necessary for the householder to select an appropriate remedial strategy. In some cases, the service technician will want to discuss the situation with his supervisor or colleagues. It may often be his responsibility to discuss the situation with the householder and to recommend a remedial strategy.

When a chimney fails the **Venting System Test** there are usually a number of remedial measures which can be used to resolve the problem, varying considerably in their cost and complexity. The strategy can be as simple as disconnecting an exhaust fan or applying a warning label, or as complicated as installing a powered make-up air supply or an induced-draft fan in the chimney.

It is not necessary that a service technician become familiar with the technical details of every potential remedial measure. All that is necessary is that the technician understand which remedial measures are most appropriate, based upon the extent of the hazard, the design of the house and the owner's financial limitations. It will be up to the owner to select the appropriate remedial measure(s) to solve the problem.

The service technician can assist the owner in identifying suitable options, and rejecting options that may not be practical. The service technician understands the systems approach and is in a good position to recognize the severity of the problem and evaluate the technical feasibility of different remedial measures.

A number of remedial measures will be provided along with their key advantages and disadvantages. For more detailed information on these remedial measures see Appendix B.

### **8.2 Discussing Venting with Your Supervisor**

If the service technician's tests and inspections indicate a potential for excess chimney spillage, the findings should be reviewed and proposed solutions discussed with his/her supervisor. The supervisor may agree with the analysis, may suggest alternative solutions, or may decide that it is necessary to conduct further investigations. The service technician should not make decisions on behalf of the customer or his employer, unless he has been authorized to do so.

### 8.3 Discussing Venting Safety with the Homeowner

When interpreting the results of a **Venting System Test** for the benefit of a homeowner, there are three points to keep in mind:

- \* If a house or chimney is subjected to remedial measures or retrofit following the **Venting System Test**, it may be necessary to re-test the house after completion. This will be true for any change that significantly increases the envelope tightness, venting exhaust capacity, or decreases the chimney draft.
- \* In cases where a house fails the **Venting System Test**, it is especially important to emphasize the potential for spillage. The probability of chimney spillage depends upon a wide range of factors such as:
  - equipment problems due to poor maintenance, damage and defects;
  - down-drafting of combustion products in chimneys, vents and flues due to excess exhaust of air from the house, inadequate air supply, and airtightness of the house envelope; and
  - improper installation of equipment, chimneys, vents and flues.

In fact, spillage may rarely or never occur.

A fireplace that exhausts large quantities of air causing excess house depressurization is the most common reason why chimneys fail the **Venting System Test**. Fireplaces do not operate well or safely in many houses, unless additional air is supplied to the fireplace room throughout the course of the fire, especially at the beginning and end. Educating homeowners about safe fireplace operation is often part of the remedial strategy in houses that fail the test. It should be pointed out that a fireplace without doors and an outdoor air supply is not permitted in some Provincial Building Codes covering new house construction. Installing fireplace doors and providing an outdoor air supply in older houses can improve fireplace operation and occupant safety. The traditional type of fireplace requires special care and attention if it is to be operated safely in a modern or modernized house.

In the past, most service technicians have responded to pressure-induced spillage problems by installing a combustion air duct into the furnace area or room. Combustion air ducts are usually 4-6 inches (100 to 150mm) in diameter (a size which satisfies code requirements for combustion air). This traditional response still meets both gas and oil code requirements, but does not address the problem caused by venting systems interacting with other exhaust devices competing for air. The code solution is to provide combustion air, not make-up air. That is, it may not prevent the appliance from spilling the products of combustion into the house, but will help to

ensure that there is adequate oxygen for complete combustion so that little or no carbon monoxide is produced.

In many houses with a pressure-induced spillage problem, it has been found that these typical combustion air ducts have a negligible effect on the house depressurization level because they are too small, and do not represent an effective remedial measure to reduce spillage. Larger, better designed air ducts will supply more air and may avoid unsafe levels of house depressurization. But supplying more air creates new problems such as impractically large holes, high heating costs, and occupant discomfort from cold air. The service technician must then consider issues such as how to control air supply to houses and how to temper, mix, and/or distribute the incoming outdoor air.

A larger air duct with automatic controls and heating elements is no longer a "simple" solution. A better solution may be to improve the chimney draft, or change the way in which the household ventilation system is operated. Only by considering all the options it is possible to select the best remedial strategy.

## **8.4 Remedial Measures**

### **8.4.1 New Appliances**

#### **Advantages:**

- \* Saves energy
- \* May replace old appliance that needs replacement anyway
- \* Eliminates the need for a chimney in some cases

#### **Disadvantages:**

- \* Expensive
- \* Sometimes not as reliable

#### **8.4.2 Disconnect or Label Exhaust Devices**

##### **Advantages:**

- \* Low cost

##### **Disadvantages:**

- \* Relies on occupant cooperation & understanding
- \* New occupants may not understand significance
- \* May not be practical

#### **8.4.3 Passive Make-up Air Ducts/Openings**

##### **Advantages:**

- \* Low cost
- \* Simple, not subject to mechanical failure

##### **Disadvantages:**

- \* Make area where they enter too cold through the spillage of cold outdoor air
- \* Subject to wind conditions/direction
- \* Usually must be too large to be practical
- \* Occupants usually block
- \* May introduce cold outside air even when not required

#### **8.4.4 Active Make-up Air System**

##### **Advantages:**

- \* Only comes-on when needed

- \* Reasonable price
- \* Doesn't over-cool space
- \* Opening through wall can be fairly small

**Disadvantages:**

- \* Requires wiring to interlink with other exhaust devices and heating appliance(s)
- \* Difficult to interlink with gas DHW and fireplace
- \* Requires timer to shut-off after one minute
- \* Mechanical components can fail without warning
- \* In some areas, components may have to be certified for operation in cold outdoor air

#### **8.4.5 Sealing & Adjusting Forced-Air Duct Systems**

**Advantages:**

- \* Low cost
- \* Effective
- \* Reduces entrance of soil gasses
- \* Makes heating system work better

**Disadvantages:**

- \* May not do enough to solve problem
- \* Works best when occupants keep basement door closed
- \* May not be possible if basement finished

#### **8.4.6 Flue Tightening and Insulating**

##### **Advantages:**

- \* Low cost unless complete chimney insulated

##### **Disadvantages:**

- \* Works best with long vent connectors
- \* May not be possible with most oil systems
- \* Vent may be too large and require replacing with proper size
- \* May not work where several flues are connected
- \* Won't work if inaccessible chimney cracks present
- \* Won't work with leaky steel liner in masonry chimney
- \* On oil systems, requires high pressure burners & approvals

#### **8.4.7 Leaky Heat Exchangers**

They should not be repaired, except as a temporary measure.

If heating appliance is relatively new and in good condition otherwise, heat exchanger should be replaced, if cost effective.

If heating appliance is older, replace entire appliance.

# **APPENDIX**

## **A**

# ACT CHECKLIST

## Assessment, Check and Test

### For the Potential Spillage of Combustion Products

#### Homeowner Interview

Questions	Yes	No
Are there unusual smells in the house when the heating appliance comes on?	<input type="checkbox"/>	<input type="checkbox"/>
Has the humidity in the house suddenly become very high during the winter months?	<input type="checkbox"/>	<input type="checkbox"/>
Is the house stuffy? Do family members suffer from constant headaches?	<input type="checkbox"/>	<input type="checkbox"/>
Has the house been tightened or have new exhaust devices been installed?	<input type="checkbox"/>	<input type="checkbox"/>
<i>Advise the owner that your company now automatically provides an extra service to ensure that the chimney system is working properly and that a short test will be performed.</i>		

#### Assessment

Questions	Yes	No
Was the house built after 1970, the exterior is totally stuccoed, or has been built tight or sealed, so that you consider the house to be tight and there is a potential for spillage?	<input type="checkbox"/>	<input type="checkbox"/>
If the house appears tight, are there any exhaust devices with a combined capacity greater than 150 cfm?	<input type="checkbox"/>	<input type="checkbox"/>
Are there are symptoms of combustion spillage?	<input type="checkbox"/>	<input type="checkbox"/>
Are there are several exhaust devices with a total capacity of greater than 250 cfm and symptoms of spillage?	<input type="checkbox"/>	<input type="checkbox"/>
<i>If the answer to any of these questions is yes, and after the "Test" there are symptoms of spillage, recommend the "Venting System Test" to the owner.</i>	<input type="checkbox"/>	<input type="checkbox"/>



**Check**

Questions	Yes	No
Check the chimney from outside, is there damage or efflorescence of a masonry chimney?		
Inspect a masonry chimney from clean-out door or remove the vent connector, with a mirror and a flashlight - is the chimney blocked or in poor condition?		
Are there any symptoms of a cracked heat exchanger such as: * On oil furnaces, black greasy or oily marks at duct joints or supply outlets * On gas furnaces, flames disturbed by air leaking from the heat exchanger * Smoke pencil indicates air being blown out of the combustion chamber area when the fan is operating and the furnace is cool?		

**Test**

**Preparation for Test**

Close all exterior doors and windows	Check wind speed-light winds desirable
Turn-on all exhaust devices (dryer, range hood, exhaust fans, central vac, kitchen BBQ, etc)	Open fireplace dampers and place propane stove in fireplace and ignite to simulate fire.
Turn-up thermostat	Turn-off furnace in basement
Turn-off hot water valve (gas/oil DHW htr)	Prepare smoke pencil

Questions	Yes	No
With the heating appliances still off and cool, is there spillage from the draft hood or diverter of a gas appliance or the barometric damper and the inspection port of an oil fired appliance?		
If spillage is detected, turn-on the heating appliance - does spillage cease within 30 seconds?		
If spillage ceased, test is completed and the house has passed. If spillage continues, the house has failed the test and the owner should be warned in writing of the potential hazard and recommend the Venting System Test. Remedial measures should also be recommended in writing. Did the System pass this spillage test?		

\* Re-open the domestic hot water main valve.

\* Return the thermostat setting to original setting.

If weather conditions were unsuitable (too windy or very cold) for the above test to simulate worst-case conditions, recommend that the test be conducted at another time.

## CHECKLIST FOR THE VENTING SYSTEM TEST

### 1. PREPARATION

- Complete top of Report Form
- Record outdoor temperature and wind
- Switch off fans, furnace and water heater
- Close windows and exterior doors and hatches
- Close int. door to pass. & basement rooms
- Install wood fire simulator and Close up fireplace
- Set-up pressure gauge, extend tap to exterior, zero
- Record pressure fluctuations, install pres.avg if req'd
- Close furnace room door, if present.

### 2. TEST

- Operate blower and record pressure
- Open basement and furnace room doors
- Operate exhaust fans and record pressure
  - dryer  bath  bath 2  bath 3
  - kitchen range  barbecue  vacuum
  - other
- Operate fireplace and record pressure
- Open fireplace doors, damper and air supply
- Temporarily open window (or door) to outdoors
- Light wood fire simulator
- Close window (or door) and record pressure
- Check furnace for backdrafting and, if backdraft exists, open a window or door to outside during the first few seconds of furnace operation

- Adjust house thermostat to high and begin timing furnace spillage
- Check spillage along vent pipe
- Record the duration of start-up spillage
- If spillage exceeds 30 seconds, turn down house thermostat, open a window, let furnace cool, and check again Run a hot water tap to operate water heater
- Time spillage from water heater
- Check spillage along vent pipe
- Record duration and quantity of spillage (furnace and water heater)
- Turn off fire and close fireplaces
- Record pressure

### 3. CLEAN-UP

- Reset house thermostat
- Turn off the hot water tap
- Switch off exhaust fans
- Open doors and windows (as found)
- Switch off furnace blower switch
- Reset two-way fan controls
- Pack up gauge and tubing
- Pack up wood fire simulators

**House Depressurization Limits (HDLs)**

<b>Appliance</b>	<b>Chimney Height to Closest Metre</b>	<b>H.D. Limit-Pascals Unlined Chimneys on Exterior Walls</b>	<b>H.D. Limit-Pascals Metal-Lined Insulated or Interior Chimneys</b>
Gas - Fired Furnace, Boiler, or Water Heater	4 or less	5	5
	5 - 6	5	5
	7 or more	5	7
Oil - Fired Furnace, Boiler or Water Heater	4 or less	5	5
	5 - 6	5	5
	7 or more	5	5
Fireplace (wood or gas)	NA	5	5
Airtight Wood-Stove or Fireplace	NA	10	10
Appliance with Retrofitted Induced Draft Fan	NA	10	15

**VENTING SYSTEM TEST REPORT FORM**

Test Date \_\_\_\_\_

Report Date \_\_\_\_\_

**TEST IDENTIFICATION**

Company name: \_\_\_\_\_

Address: \_\_\_\_\_

Tester Name: \_\_\_\_\_

Address of Dwelling: \_\_\_\_\_

Reason for Test: \_\_\_\_\_

**TEST CONDITIONS**

Outdoor temperature: \_\_\_\_\_ Wind direction: \_\_\_\_\_

Approximate wind speed and variability: \_\_\_\_\_

Pressure gauge type - Inclined manometer: \_\_\_\_\_ Other: \_\_\_\_\_

Pressure averaging system - None \_\_\_\_\_ Other \_\_\_\_\_

Deviation from standard procedure: \_\_\_\_\_

### HOUSE DEPRESSURIZATION LIMITS

APPLIANCE	H.D. LIMIT (Pa)
1. Furnace	
2. Water Heater	
3. Wood Fireplace	
4. Other _____	
5. Other _____	

### PRESSURE READINGS\*

SYSTEMS OPERATING	HOUSE DEPRESSURIZATION	EXCEEDS H.D. LIMIT FOR APPLIANCE NO.
		1   2   3   4   5
Blower		
Two-way fans		
Exhaust fans		
Fireplace _____		
Fireplace _____		
Furnace & water heaters (fireplaces off)		 

\* Completion of this chart is optional, however, it may be useful when trying to determine the most appropriate remedial measure.

**Spillage Observations**

		Quantity			Duration		
		None	Slight	Major	Less than 30 sec	More than 30 sec	More than 3 min
Furnace	Tight House						
	Open House						
Water Heater	Tight House						
	Open House						
Other	Tight House						
	Open House						

**FOLLOW-UP ACTION**

Discussion with occupants: \_\_\_\_\_

Notification of authority: \_\_\_\_\_

Remedial measures: \_\_\_\_\_

**Urgency of Remedial Measures**

\_\_\_ None \_\_\_ Urgent \_\_\_ Today \_\_\_ Routine \_\_\_ Optional

Details: \_\_\_\_\_

## **THE CHIMNEY PERFORMANCE TEST**

### **For Furnaces, Boilers and Domestic Hot Water Heaters**

1. **Gas Appliances:** Tape the draft hood closed or block it off with a piece of foam plastic insert the thermometer through a 1/4 inch hole (use a drill or punch and hammer) located near the base of the chimney on a straight section of pipe. Later you will measure the draft in this same location with the draft hood open and operating normally.  
  
**Oil Appliances:** Insert a thermometer into a 1/4" hole on a straight section of pipe near the base of the chimney with the barometric damper held closed.
2. Partially open a nearby door or window to the outside.
3. Begin operation of the appliance. If the appliance is a furnace (or boiler), turn up the house thermostat. If it is a hot water heater, turn on a hot water tap.
4. Once the appliance begins to operate, begin timing (see Figure 6.1).
5. Set up the manometer on a level surface, close to the 1/4 inch (5 mm) hole. Open the pressure ports, connect the tubing, and zero the gauge.
6. After 5 minutes of appliance operation, record the temperature of the chimney gases, and remove the thermometer.
7. Insert the static pressure probe in the 1/4 inch (5 mm) hole (see Figure 6.2). (The probe should not penetrate into the pipe more than 1/8th inch (2 or 3 mm)).
8. Record the static pressure, and remove the pressure probe.
9. Shut off the appliance by resetting the house thermostat (or turning off the hot water tap).
10. Close the door or window to the outside.
11. Pack-up the test equipment.
12. Evaluate the adequacy of chimney gas temperatures using Table 6.1.
13. Evaluate the adequacy of static pressure by comparing the static pressure with the House Depressurization Limit (HDL) for the system being tested. Static pressure should be at least 1 Pascal (.004 IWC) above the HDL. Refer to Table 6.2 for HDL's.

## TEMPERATURE GUIDELINES FOR PRODUCTS OF COMBUSTION

Chimney Type	Chimney Height (to nearest metre)*	Minimum Temperature** °C (°F)		Maximum Temperature °C (°F)	
		GAS	OIL	GAS	OIL
Un-insulated	4 or less	210 (410)	230 (446)	300 (572)	430 (806)
Exterior	5, 6	230 (446)	250 (482)	300 (572)	430 (806)
Masonry	7 or more	270 (518)	290 (554)	300 (572)	430 (806)
Other Types	6 or less	210 (410)	225 (437)	300 (572)	430 (806)
	7 or more	230 (446)	250 (482)	300 (572)	430 (806)

\* Vertical distance from chimney to cap.

\*\* Values are approximated, measured without the addition of dilution air from either a draft hood, diverter or barometric damper, and are intended to avoid condensation occurrence at chimney top after 5 minutes of appliance operation, with an outdoor temperature of -10°C (14°F) and a dew point of 58°C (136°F). The minimum temperatures shown do not have to be achieved if chimney performance (adequate draft is established) becomes satisfactory at a lower temperature. Maximum temperatures shown reflect safety concerns, for the purpose of energy efficiency, normal operating maximum flue gas temperatures should be much lower.

## HOUSE DEPRESSURIZATION LIMITS (HDLs)

Appliance	Chimney to Closest metre	H.D. Limit in Pascals	
		Unlined Chimneys on Exterior Walls	Metal-Lined Insulated or Interior Chimneys
Gas-Fired Furnace, Boiler or Water Heater	4 or less	5	5
	5,6	5	5
	7 or more	5	7
Oil-Fired Furnace or Water Heater	4 or less	5	5
	5,6	5	5
	7 or more	5	5

1 Pascal = .004 inches of water column



**HEAT EXCHANGER LEAKAGE TEST**

**CHECKLIST AND REPORT FORM**

- \_ Check for blower switch on furnace
- \_ Check tools: smoke pencil, tape, flashlight, (for gas furnaces, piece of foam) etc.
- \_ Turn off and tape household thermostat
- \_ Blow out pilot light (gas furnace only) and check to see valve shuts off
- \_ Oil Furnace - seal exit port(s) of combustion chamber
- \_ Gas Furnace - seal entrance to combustion chamber (burner area) with piece of foam rubber
- \_ Pre-check for air movement using smoke pencil and flashlight
- \_ Switch on blower and check again
- \_ Shut off blower
- \_ Unseal the combustion chamber
- \_ Light pilot (gas furnace only)
- \_ Un-tape and turn thermostat to high
- \_ Check for proper operation (no spillage)
- \_ Re-set house thermostat
- \_ Clean-up tools and materials

ADDRESS: \_\_\_\_\_ DATE: \_\_\_\_\_

\_\_\_\_\_ COMPANY: \_\_\_\_\_

TESTER: \_\_\_\_\_

FURNACE TYPE: \_\_\_\_\_ DEVIATIONS FROM

STANDARD PROCEDURES (if any): \_\_\_\_\_ RESULTS: \_\_\_\_\_

\_\_\_\_ No leakage detectable: or:

AMOUNT OF LEAKAGE	LOCATION	COMMENTS
_____	_____	_____
_____	_____	_____

RECOMMENDED FOLLOW-UP ACTION: \_\_\_\_\_

\_\_\_\_\_

# **APPENDIX**

## **B**

### **REMEDIAL MEASURES**

## **REMEDIAL MEASURES**

### **B.1 Introduction**

This section will provide detailed information on many of the possible remedial measures that can be taken to solve combustion venting problems.

### **B.2 Consider Simple Solutions First**

Occasionally there are some simple and obvious solutions for a house that suffers from chimney spillage or backdrafting problems. Although the simplest solutions are sometimes too costly or too inconvenient to satisfy homeowners, they should always be considered first before other, more complicated and often less effective measures.

### **B.3 New Appliances**

A new appliance may be suitable as a remedial measure, especially if the existing appliance is on its last legs. A variety of new appliances are now available that can safely withstand significant house depressurization.

Induced draft gas fired furnaces and water heaters incorporate a fan inside the appliance and will vent safely and properly, even when houses are depressurized to unusually high levels. The extra cost of these appliances may be more acceptable if a new appliance is needed anyway. The induced-draft appliance generally has a better seasonal efficiency which recovers the extra initial investment. Most induced draft appliances can be vented out through a wall, eliminating the need for a chimney.

**Note:** It is possible that removal or sealing of the chimney may cause an indoor air quality problem such as excessive moisture.

If the existing furnace is connected to a masonry chimney that needs considerable repair to make it safe, the induced draft appliance provides a solution. With oil furnaces, often a high pressure burner can be installed. This burner along with a sealed smoke pipe can force combustion products into and up a chimney with the presence of moderate negative pressure.

Problems can still occur with induced draft appliances if they are connected to standard B Vents or share a chimney with other natural draft appliances. The gases may short-circuit into the house through the leaks or connections in the flue or back-out through a naturally aspirated DHW heater.

Sealed combustion gas fired appliances are less common than induced-draft appliances, but are almost immune to combustion spillage problems because the combustion process and bi-products are totally isolated from the

house. A sealed combustion system may have a doubled-walled vent that serves both as a combustion air supply, and as an exhaust outlet or the appliance may have the vents side by side, one supplying fresh air and the other exhausting. Although the sealed appliance may be located indoors, it is essentially isolated from the effects of house depressurization. The vents are typically installed through a nearby wall to the outdoors, and thus, like most induced draft appliances, householders may also benefit by avoiding the inevitable maintenance cost for upgrading old and deteriorating masonry chimneys.

#### **B.4 Disconnect or Label the Exhaust Devices**

The **Venting System Test** will sometimes identify potential spillage problems due to the operation of large numbers of exhaust fans or to a single powerful fan that the homeowner might not consider to be a necessity. The easiest solution in this case is to safely disconnect this exhaust device and label it as unsafe to operate. As long as the homeowner has no problem with this approach, it is a sensible, low-cost way, to reduce the possibility of unsafe levels of house depressurization. Unfortunately, few homeowners will feel that any of their exhaust devices are unnecessary.

In a few cases, labels alone may be enough to warn occupants against operating too many powerful exhaust devices at once. Labels can also advise the occupants to provide extra make-up air at the time the powerful exhaust devices are being used. If labels are being installed as a safety measure in a home, they should be constructed of durable material and mechanically fixed to a visible location near exhaust devices. Some suggested wording for labels are provided below:

1. **CAUTION: Avoid Chimney Spillage Problems.**  
Keep fireplace doors shut and outdoor air supply ducts open as fire burns down.  
Date:                                  Technician Initials:  
Company Name
  
2. **CAUTION: Avoid Chimney Spillage Problems.**  
Provide additional air supply from outdoors while operating this (exhaust fan/fireplace).  
Date:                                  Technician Initials:  
Company Name
  
3. **Caution: Avoid Chimney Spillage Problems**  
Ensure that this blower compartment door is left closed at all times.  
Date:                                  Technician Initials:  
Company Name

#### **B.5 Passive and Active Make-up Air Ducts**

A make-up air duct can increase the supply air to a house and reduce house depressurization caused by

operation of exhaust fans, fireplaces, and other vents. If the make-up air duct relies on the indoor/outdoor pressure difference (as opposed to fans) it is referred to as a "passive" make-up air duct. If it has a motor powered fan, it is an active make-up air system. (See Figure B.1.)

Make-up air ducts must be fitted with a rain hood and insect screen at the inlet. It is ducted through the wall or sill plate to a suitable location indoors. The duct is limited in size (usually by the height of the sill plate), to 6 inches (150mm) in diameter. Larger ducts are difficult to install, and unless they are equipped with automatic dampers, are likely to be blocked off by occupants who become uncomfortable due to the entry of cold outdoor winter air. In fact, to ensure that these ducts do not provide cold air to the house, thereby encouraging the occupants to block the opening, automatic dampers are highly recommended for all installations. The make-up air duct typically terminates at either the ceiling or floor of the furnace room. Sometimes it terminates inside, or close to the return air plenum of the furnace air circulation system.

### **WHEN TO RECOMMEND A MAKE-UP AIR DUCT**

Passive make-up air ducts are not suitable remedial measure in many houses, because a passive air intake will rarely match the exhaust air flow of a powerful fan.

Make-up air ducts are most suitable for furnaces and water heaters in very tight enclosures, such as furnace rooms, where air is required for combustion and to improve chimney performance,

They may also be suitable for very tight houses, because even a small duct will increase the house leakage area significantly. For example, a single 7 inch (175mm) make-up air duct may provide an additional 85 CFM (40L/S) at critical house pressures (0.02 in. W.C./5 pascals). This may be sufficient, in combination with the existing air leakage, to balance exhaust fans with capacity as high as 200 CFM (100L/S).

Make-up air ducts are most suitable in mild climates, where incoming air will not cause excessive cooling.

Success with make-up ducts has not been great because air supply is often restricted by screening, bends, hoods and duct design. They would be more effective if the duct is correctly sized and installed and left free from tampering.

### **RECOMMENDED DESIGN FEATURES AND MATERIAL FOR MAKE-UP AIR DUCTS**

The necessity of following building code requirements when designing a make-up air duct should be determined through discussion with your supervisor or with local building inspectors.

Often code requirements are bare minimums and do not take into consideration such things as how to avoid discomfort or high heating costs from the addition of a make-up air supply. These issues are discussed below. Be careful - the recommendations in this manual may not always agree with requirements of national or local building or equipment installation codes.

If the technician has decided to recommend the installation of a make-up air supply duct as part of his remedial strategy, he should consider incorporating the following design features:

#### INLET LOCATION

The duct should exit from the house at least 3 feet (one meter) from any gas piping, oil fill or vent pipes, windows, doors, air intakes, or exhaust, clothes dryer exhaust, or any other opening in the building envelope. The height above ground should be sufficient to avoid blockage by winter snow.

Avoid locating the inlet opening inside a storage shed, garage, or enclosed area. Locate the duct opening away from obvious outdoor pollution sources such as garbage bins, busy street traffic, or the neighbour's wood burner chimney. If the make-up air duct is to be connected to the cold air return plenum of the furnace, the wall inlet for the duct should be located reasonably close to the return air plenum for maximum air delivery. When make-up air ducts are connected to a return air plenum, they should be designed in accordance with acceptable trade practices and insulated.

#### MATERIALS

The duct outside inlet will need a rain louvre or cap and an insect/rodent screen. Louvres and screens restrict the opening, cutting airflow by almost 50%, therefore the duct size must be increased at the inlet to maintain the minimum required free area. One solution to this problem is to use a duct expander. The expander will allow the technician to increase the area of the duct inlet opening thereby eliminating any additional resistance to air flow from the screening etc.

After installing a duct through the wall, sealant should be used to prevent rain entry from outside and air leakage around the duct.

Vapour barrier-covered insulation should be wrapped around the ducts indoors to avoid condensation dripping off the cold duct. Foil-face flexible duct insulation is available in wide rolls that allow for easy application. The insulation can be wrapped around the duct and held in place with wire, tape, or staples. Seams of the vapour barrier should be taped. Alternatively, insulation sleeves can be purchased that slide or snap around the duct. The best approach is to use insulated flex or rigid duct.

Rigid ducting allows almost twice the airflow in a small diameter duct. However, flexible ducting eliminates some joints and leakage, allows for easier lay-out and handling, and can be conveniently purchased cut-to-length.

**FIGURE B.1 Passive and Active Air Supply**

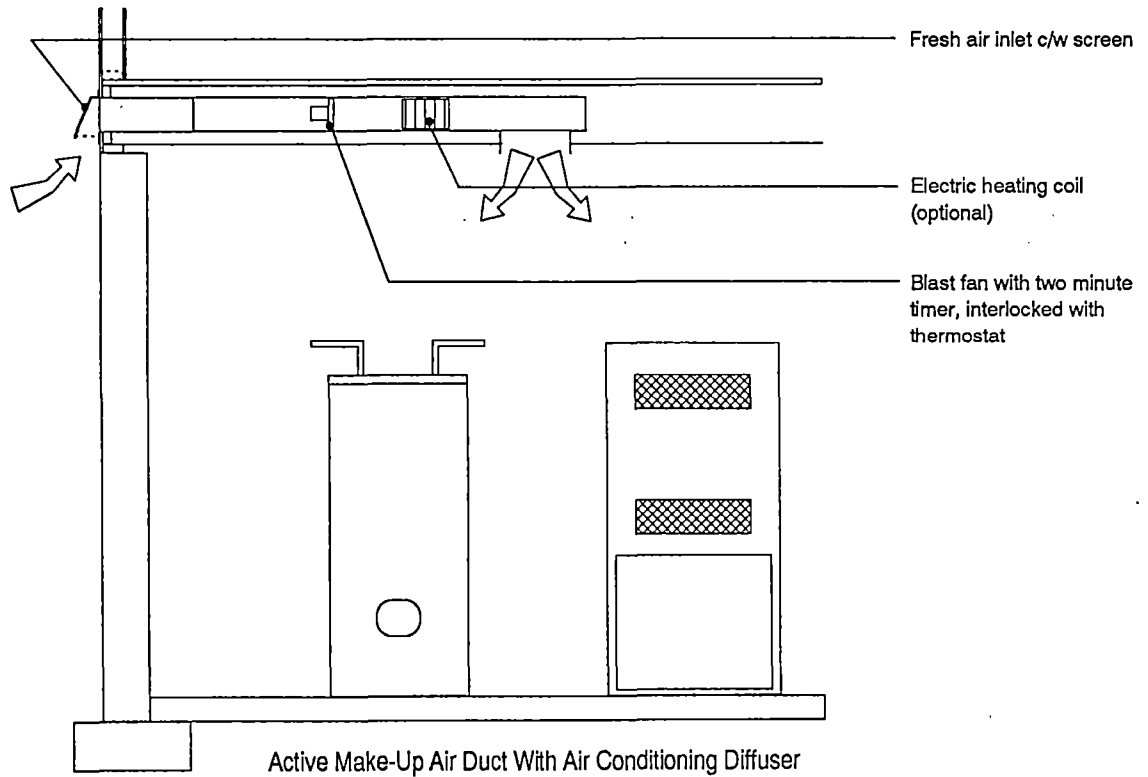
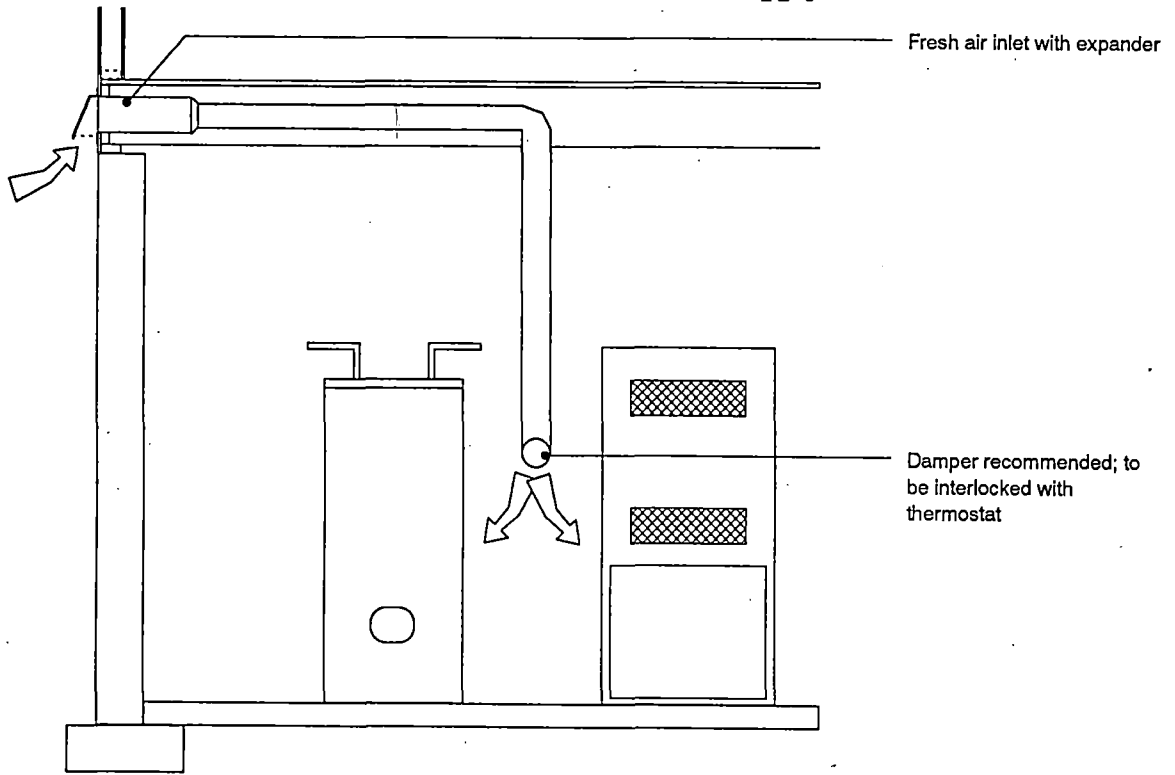

## **AIR DELIVERY INDOORS**

The most common delivery strategy is to connect a make-up air duct to the return air plenum of a forced air distribution system. The outdoor air is thus filtered, heated, and eventually distributed. In cold climates, this design can lead to discomfort, especially if the furnace blower operates during the furnace burner off cycle. Even if the blower only operates when heat is called for, cold air can pool at the base of the furnace, and the result is a sudden blast of cool air when the appliance begins to operate. Most spillage occurs at start-up so unless the blower is set to run continuously it will not provide combustion air at the time that it is most needed. Thought should also be given to a suitable control strategy and advice obtained from the local building authorities, before connecting a make-up air duct to a return plenum.

If you choose to recommend the installation of a fresh air supply duct directly into a basement area, steps should be taken to avoid pooling of cold air and discomfort for the occupants. One solution is to terminate the duct at ceiling level using an air-conditioning diffuser. An air-conditioning diffuser is a round or square grill, with vanes that act to spread the air out across the ceiling before it drops to the floor. This style of diffuser will improve mixing and tempering of the outdoor air, but will not prevent the area from becoming cool. Diffusers can be located above a heating appliance such as a boiler or hot water tank. This will further assist in tempering the fresh air (but don't create condensation problems by dropping fresh air directly onto a vent connector or vent pipe). Another option is to install an electric resistance coil heater in this duct. Of course, the addition of diffusers and/or electric coils will result in greater resistance to the air flow through the duct which must be accounted for.

A motorized damper on the fresh air duct is an option that can make ventilation control easier. Dampers are now available that are certified for use on combustion/dilution air ducts. Motorized dampers exist for different sizes of ducts from 4 inches (100mm) to 8 inches (200mm). Dampers are usually powered by 24 volts.

Wiring the damper to the house thermostat will ensure that fresh air is supplied only when the furnace is warming and circulating the air. This type of wiring work must be completed by a tradesman licensed for work on the appliance.

### **B.6 Combustion Air Design Required by Codes and Standards**

Although the primary concern with providing air to houses should be to eliminate the potential for pressure-induced spillage, the service technician may also be obligated to satisfy code requirements for combustion air supply (See Figure B.2.).

The codes that determine the type and size of combustion air supply required in houses vary from province to province and according to the type of fuel and appliance. Combustion air requirements in the codes have also been revised on various occasions over the past few years and a review of these requirements may be worthwhile. The codes cover new construction and alternatives to existing buildings. The types of renovations that must meet the code are defined locally.



Since most provinces will eventually revise their codes to agree with the latest national codes, this text provides a description of only the most recent national codes. Your local building or utility inspector will be familiar with any variation between the requirements presented in this text and the requirements of your province.

The Canadian Gas Association's Standard "CAN 1 B149" is a code that applies to gas burning appliances and equipment. Although originally this code required separate combustion and ventilation air for vented appliances, the latest revisions have combined these into one requirement for a "combustion/dilution" air supply.

According to the 1986 version of the B149 code for gas-burning appliances a combustion air supply duct must be provided when a house meets either of the following two situations:

1. The house is of tight construction ("has windows and doors of either close fitting, or sealed construction and the exterior walls are covered by a continuous, sealed vapour barrier and gypsum wallboard, plywood, or similar having sealed joints" - a house built in accordance with the 1985 and 1990 National Building Codes); or
2. The house has an ELA of less than 75 square inches (500 square centimetres).

In cases where a combustion/dilution air duct is required, its size is determined by the table below. Essentially, the size of the duct must be increased as the total heat input of the vented appliance increases. In a typical house with a gas water heater of 35,000 BTU per hour, and a gas furnace at 100,000 BTU per hour, the combined heat input is 135,000 BTU per hour. Table B.1 shows that a combined heat input of 135,000 BTU per hour will require a combustion/dilution air duct approximately 5 inches (125mm) in diameter.

**Note: The B149 code also requires that a furnace or water heater enclosed in a furnace room, be provided with easy access to household air. In general, an open area of 1 square foot (1,000 square centimetres), should connect the furnace room with other areas of the house. This opening should be at knee level (from 6 to 18 inches/150mm to 450 mm above the floor).**

According to the code, the "free area" of the opening for the combustion/dilution air inlet, must be at least as great as the minimum required duct diameters. In other words, the screen and hood that cover the inlet must not further restrict the total area. In practical terms, this means that the inlet opening from the outside should be 1 inch (25mm) to 2 inches (50mm) larger in diameter than the rectangular inlet. The duct can then be reduced to the minimum requirement, or continue into the furnace room at the larger diameter.

The code requires that a combustion/dilution air duct inlet opening from outdoors be located at least 1 foot (300mm) above the ground level. No dampers are permitted on combustion/dilution air ducts, unless the dampers are interlocked with the furnace and water heater. Interlocking means that the appliances will be unable to operate if the damper fails to open.

If you are required by code to provide a "combustion air duct", but also want to install a custom design make-up air duct, consider installing two separate ducts - one that meets the code, and one that prevents unsafe house depressurization (two smaller ducts are usually easier to install than one larger duct).

**FIGURE B.2 Gas Code Method of Combustion Air Supply**

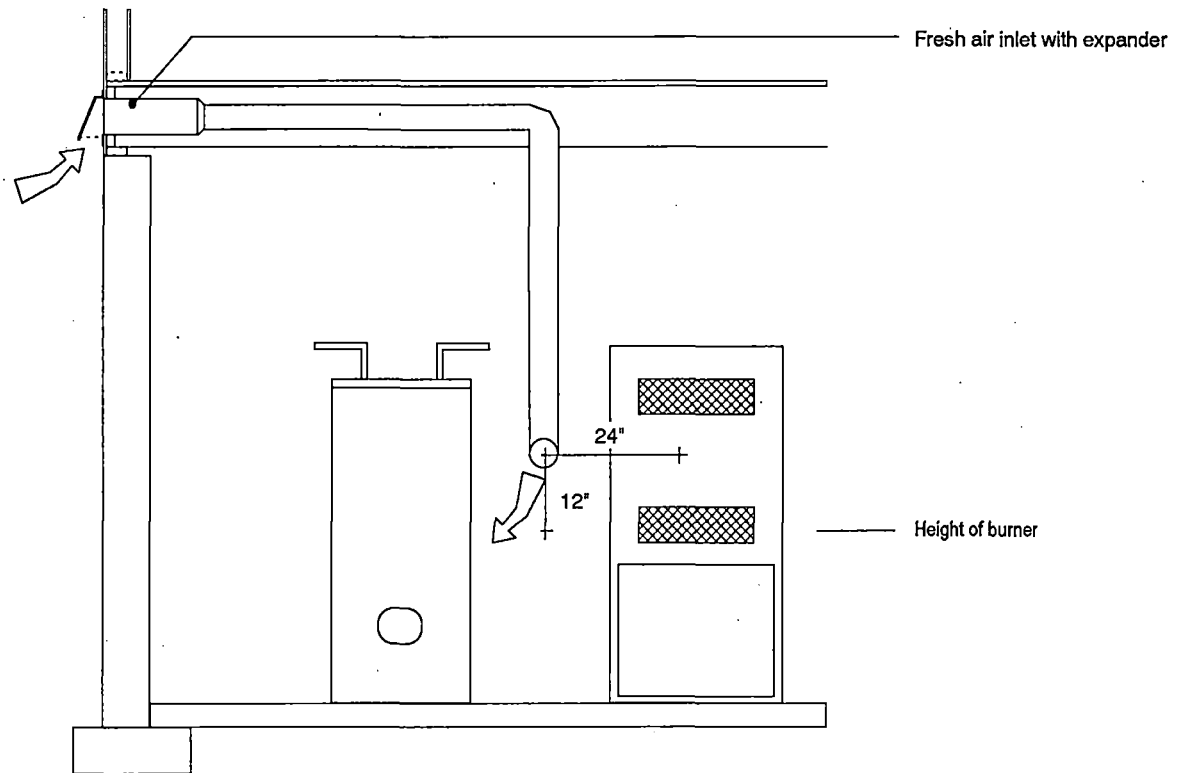

**FIGURE B.3 Oil Code Combustion Air Supply Method**

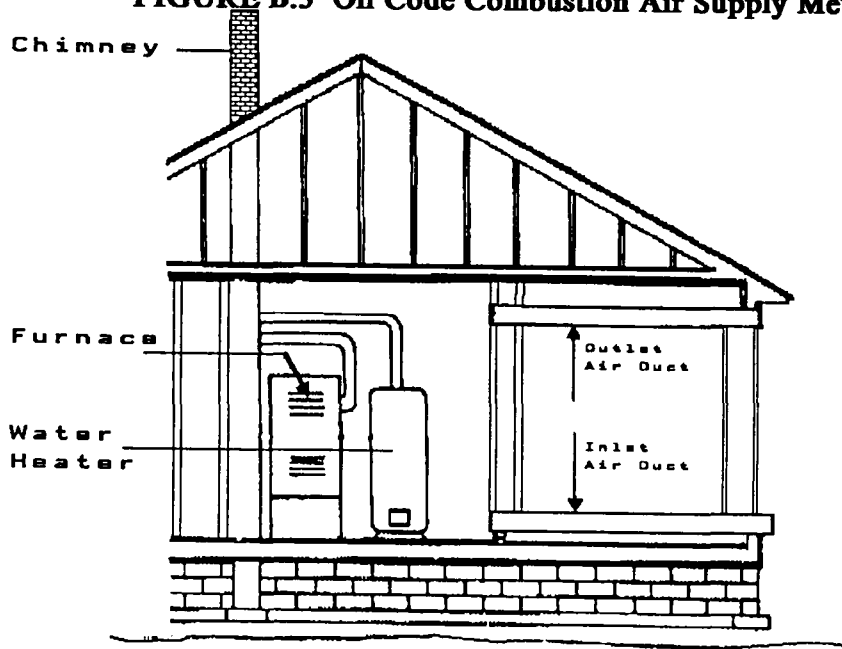

**Appliances Located in  
Confined Spaces -All  
Air from Outdoors**

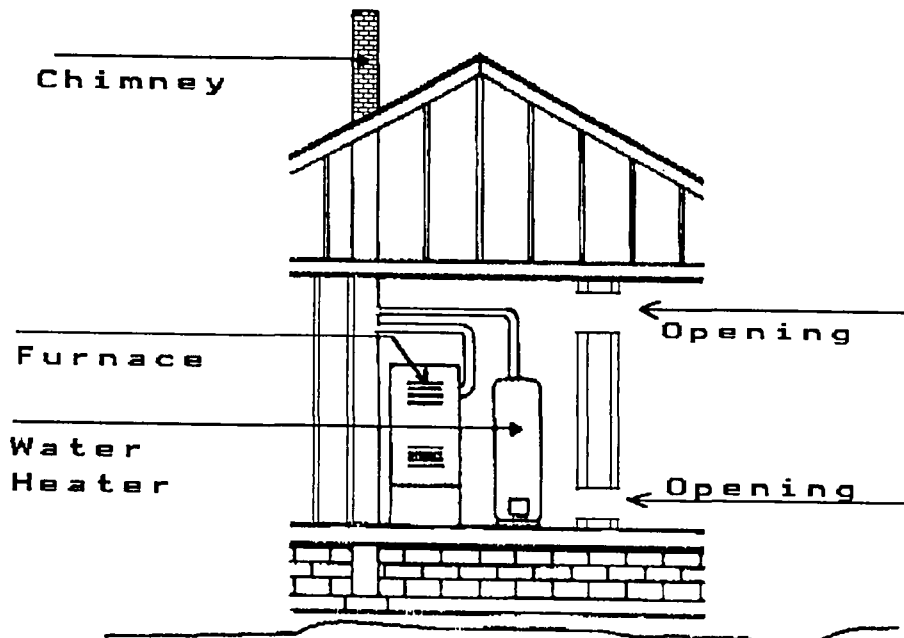

**Appliances Located in  
Confined Spaces, All Air  
From Inside Building**

According to CSA B139, oil-burning appliances shall be installed only where an adequate supply of combustion air is available to assure proper combustion, and where provision is made to compensate for the air drawn from the area by other appliances, such as exhaust fans, clothes dryers, or fireplaces.

CSA B139 does not mandate specific amounts of supply air, although recommendations are provided for air to appliances in tight buildings and for appliances in confined spaces. The size of combustion air openings can vary when special engineering methods have been approved by the regulatory authority (See Figure B.3.).

### **B.7 Sealed and Adjusted Air Circulation Systems**

A typical forced air furnace contains a large blower fan, capable of blowing about 600 CFM to 1600 CFM or more (300 to 800 L/S) through the air circulation system. Theoretically, this blower is used only to move air around the house, drawing cool air through return openings, passing this air through the heat exchanger of the furnace and then supplying this same air back to various rooms in the house through supply registers. It is common however, for a furnace blower fan to depressurize the room or basement area where the furnace and water heater are located and thereby contribute to pressure-induced spillage.

Depressurization occurs because a blower tends to suck a disproportionate amount of air from the region immediately surrounding the furnace. For example, the return air ductwork will typically leak around the joints, the connection to the furnace casing, the filter slot, and the blower compartment door (See Figure B.4.). The air sucked into the return air ductwork through these leaks will then be supplied to far away rooms that may be separated from the furnace area by tight doors.

Supply air is sometimes exhausted from the house entirely - another reason why furnace blowers may cause depressurization. For example, supply air ductwork may leak or distribute air into heated garages, crawl spaces, attic spaces, and even to inter-floor spaces which connect to outside walls and the outdoors.

Sealing the forced air distribution system involves the tightening of both return air and supply air ducts and plenums, so that both sides of the distribution system move a proportionate amount of air through different zones in the house. In cases where sealing is not possible, the ductwork may need to be adjusted so as to eliminate depressurization of the furnace area. One adjustment is to provide for more return air from other portions of the house or from the outdoors. Another adjustment is to supply more air into the room where the furnace is located. Adjusting the distribution system may effect the heat delivery to rooms in the house, especially if householders already have problems. For this reason, the forced air system may need to be re-balanced for this after adjustments. In general, after adjusting the forced air system, you should advise the occupants to adjust the dampers on supply registers over the course of several days, until heating is even and comfortable, from room to room.

### **WHEN TO RECOMMEND SEALING OR ADJUSTING THE AIR CIRCULATION SYSTEM**

Sealing and adjusting the air circulation system is a suitable remedial measure for every home with a forced air

furnace that causes significant amounts of depressurization in the furnace room, the basement or in the house as a whole.

Sealing ductwork is especially important in houses where the blower fan operates on a continuous basis, such as those with two speed blower fans, or where householders prefer to have the blower fan operating on continuous high speed basis.

Some styles of houses that are particularly prone to depressurization by the furnace blower include: houses with a separate furnace room sealed by a solid door; houses where all the supply air ductwork is located in an attic or crawl space; and, houses where the furnace is located in the basement that is separated from the rest of the house by a plywood subfloor and a tight door at the top of the basement stairs.

It is usually possible to avoid depressurization of forced air ductwork, if not by sealing the ducts, then by forcing additional air into the furnace room.

The preferred strategy is to equalize pressures solely by tightening ductwork, since this improves heat distribution to remote areas of the house and thereby improves efficiency and comfort. Tightening ductwork is not always possible, however, because ductwork may be hidden behind finished ceilings or in such areas as crawl spaces where access is limited. Tightening ductwork is also a tedious and time-consuming job.

Adjusting the ductwork by supplying additional warm air to the furnace room may cause new problems, such as cold rooms in other part of the house and is also easily sabotaged by uninformed occupants who decide to seal up supply registers in the basement or furnace area.

#### **SUITABLE DESIGN FEATURES AND MATERIALS**

Normally the best material for sealing both the return and supply air ductwork is a paint-on sealant, or foil-faced tape with a peel-off backing. Prior to application of the sealant or tape, all the joints and connections in the ductwork must be wiped clean with a fast-drying solvent. Areas where sealing is most required will be coated with dust and grime from years of accumulated air leakage. After wrapping tape on the ductwork, the tape should be firmly rubbed in place for maximum adhesion.

Cloth duct tape is not usually the best choice, since it tends to loose adhesion and sag or fall off after several years. If cloth duct tape is to be used, it should be wrapped twice around the duct so as to adhere to itself.

If filter slots or blower compartment doors are sucking a lot of air, these locations can be weather stripped.

Often spot leaks will occur on elbows or at the corners of plenums or around the furnace casing. Silicone sealant is appropriate for these locations, after cleaning the area.

It is recommended to search for and identify obscure leaks using a smoke pencil while the furnace blower is operating.

**FIGURE B.4 Distribution System Leakage**

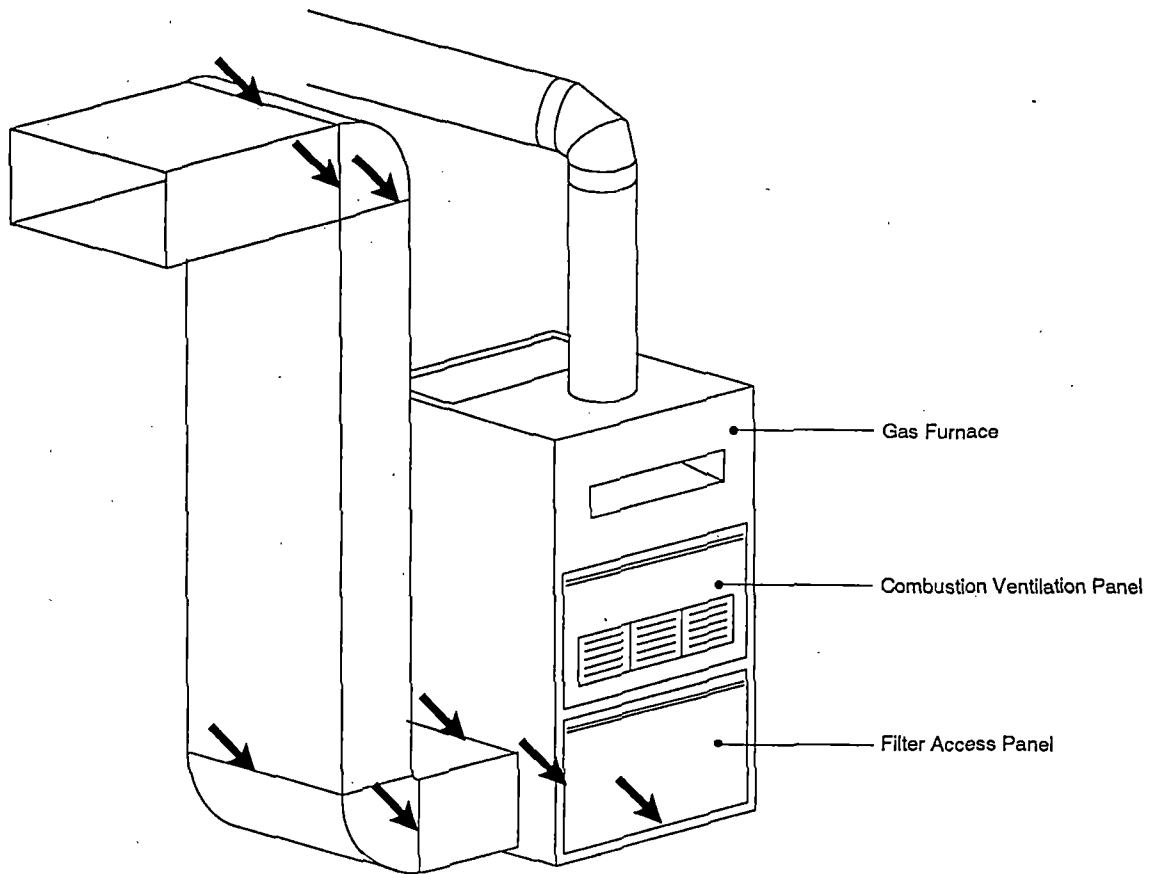

Leakage into return air duct and furnace can result in local depressurization

A warm air supply register is often needed in the furnace room to help equalize pressures. If a register does not already exist and if the furnace room is depressurized despite your efforts to tighten the ductwork, a register should be installed. Cut into the vertical plenum 12 inches (300mm) or more above the furnace, in a place where the warm air will not blow near the dilution air inlet of the furnace, and will not blow on passers by. The hole cut in the plenum should be about 6 square inches (385 square mm), and should be covered with a grill that does not include an adjustable damper. This will avoid occupants shutting down the warm air supply to the furnace room. If the hole is larger than required, it can be reduced by using foil tape behind the grill. Louvres on the grill should direct air sideways or up, but not down.

In some houses where all of the ductwork is located in a leaky crawl space, it may be easier to tighten the crawl space than the ductwork.

If ductwork cannot be tightened and if an air supply register does not eliminate depressurization, a better approach may be to undercut the door between the furnace room and the rest of the house, or provide a grill in that door. This approach helps to supplement the return air system, and equalizes the pressure throughout the house.

A common alternative to adjusting the supply and return air systems is to install a make-up air duct. A make-up air duct is connected to the return air plenum, and whenever the blower fan in the furnace is operating, outside air is sucked through make-up air duct. This helps to balance air from the warm air ductwork in other locations. A make-up air duct may create a higher operating cost, since the make-up air must be heated. The cost of cutting a hole in the wall and installing tight insulated ductwork will likely exceed cost of other tightening and balancing. However, make-up air supply may be warranted in those cases where large quantities of air are being forced out of the house by furnace ductwork that is inaccessible and therefore cannot be tightened.

Severely plugged furnace filters, or loose blower compartment doors, can cause depressurization of the furnace area even after balancing ductwork. The furnace blower must never be operated when the blower compartment door is off or even partially opened (some new furnaces have switches which prevent this from occurring). The importance of replacing filters regularly and keeping the blower compartment door closed tightly at all times, should be emphasized to the homeowner. If necessary, a label should be applied to the furnace with instructions to keep the compartment closed.

In some houses, service technicians will cut a large hole into return air ductwork to improve forced air supply to other rooms in the house or reduce air noise in the system. Obviously this approach can lead to major depressurization of the furnace area and it is not recommended.

## **B.8 Flue Tightening and Insulating**

A chimney with low draft is more susceptible to pressure-induced spillage. Leaky chimneys have low draft for two reasons:

1. Cool household air leaks into the flue, lowers average flue gas temperature and thus reduces the buoyancy or draft of the gases; and,
2. As the household air leaks into the chimney it bleeds off static pressure (or suction) from the chimney and thus draft is reduced at the furnace connection (or breech).

Leaky flues also permit more spillage of hot gases during the start-up period. This is true especially with gas-fired appliances with induced-draft fans and oil furnaces, because the burner fan re-establishes draft by forcing hot gases up the chimney. Tightening the flue reduces the amount of spillage reducing the time required for an oil-fired, or induced-draft gas-fired appliance to establish proper draft.

### **WHEN TO RECOMMEND FLUE TIGHTENING**

Flue tightening is most appropriate for flues that have obvious leaks and gaps, or for flues where spillage occurs at levels of depressurization below the HDL.

Long vent pipes or connectors will usually have more joints and therefore more leakage and can benefit more from flue tightening.

Gas connections often have longer vent pipes when a low-boy oil furnace is replaced by a high-boy gas furnace and the vent connector will be made of a lighter gauge of metal, creating a leakier flue with low draft. Since flue gas temperatures will also be lower, it is wise to compensate by tightening the flue.

Flue tightening is compatible with other remedial measures and in particular the installation of induced-draft fans. Flue tightening should, as a rule, be conducted whenever this other remedial measure is being installed.

Oversized or un-insulated flues on an exterior wall sometimes experience difficulty maintaining adequate draft and can benefit from flue tightening and insulating of the smoke or vent pipe.

With proper materials, flue tightening is a straightforward task that should be successful under most conditions.

Situations where flue tightening may not solve low draft problems include those:

- \* where the flues are partially blocked;
- \* where flues are connected to other flues, for example: more than one water heater is connected to a furnace vent connector;



or a wood stove is connected to the same flue as a furnace and water heater;

- \* where the chimney is cracked or deteriorating badly and therefore leaking in multiple and inaccessible locations; and,
- \* where there is a leaky steel liner inside a masonry chimney.

Flues can be tightened using techniques similar to those used to seal the forced air ductwork, however, different materials will be required because of the high temperature of flues 300°F to 750°F (150°C to 400°C). Even foil tapes designed for sealing warm air ducts are unsuitable for use on chimney components. Specialized high-temperature foil tape is available for wrapping joints of vent pipes and vent connectors. Muffler repair tape can also be used for this purpose, although odours may cause discomfort initially. Most sealants are relatively fire resistant once cured, but for durability, it is recommended that only suitable silicone or polysulphide sealants be used.

Repaint or fill gaps in the outside masonry with small amounts of mortar cement. A special high-temperature mortar is required when sealing the interior surfaces of masonry vent pipes or when sealing refractory bricks inside a fireplace.

It is most important when tightening flues, not to seal any sections which will need to be dismantled on a regular basis. This includes, primarily, the breech and thimble connections on most oil furnace vent pipes, since the entire vent pipe may need to be removed every few years to clear soot accumulations. These locations can be taped or crimped to ensure tightness, but do not use sealants.

Three locations require special attention and are best evaluated with a smoke pencil:

- \* the ash clean-out door in masonry chimneys;
- \* thimble or plugs on masonry chimneys; and
- \* smoke/vent collars (the vent connector must be the same diameter as the vent collar for a tight fit).

Replacing a smoke or vent pipe or connector with a double-walled or insulated vent pipe is a more expensive alternative to vent tightening with tape and sealants. A new vent pipe or connector may be warranted in cases where the existing vent pipe is damaged or extremely difficult to tighten; where the vent connector is particularly long (and therefore losing a lot of heat) or where the draft remains low, despite tightening.

Installing a metal liner in a masonry chimney is a more effective way of tightening the masonry chimney and has the added advantage of keeping the chimney warmer. A warmer chimney will have improved draft and, as a bonus, will be less vulnerable to deterioration from condensation.

## **B.9 Sealed Chimney Liners in Combination with High Pressure Oil Burners**

Oil-fired furnaces and boilers, vented by masonry chimneys, can be retrofitted to reduce the potential for combustion gas spillage and chimney problems related to condensation. An approach that has been found to work well includes the installation of a series of components:

- \* a high-pressure, efficient oil burner, often of European design;
- \* a stainless steel flue liner, sized to match the new firing rate;
- \* vermiculite insulation around the liner (must be sealed at the top of the chimney to prevent rain entry);
- \* a sealed vent pipe (with the barometric damper removed and leaky joints sealed);
- \* a wind resistant chimney cap; and,
- \* a ceramic liner for the combustion chamber.

Compared to conventional oil heating systems, a sealed and insulated chimney (See Figure B.5.) is less likely to spill gases indoors when the burner starts up. It is less affected by negative pressure and can operate with levels of house depressurization up to 10 Pa. (0.04 in. W.C.). Each of the components of this approach is important for reasons outlined below.

### **HIGH PRESSURE OIL BURNER**

The high pressure oil burner is more efficient than conventional burners. In combination with down sizing, it often achieves reductions in the fuel bill of 30 to 40%. This helps to justify the initial high cost of this remedial measure. However, the high-pressure burner is beneficial for other reasons.

A sealed venting system can experience a wide range of pressure changes than is normal for a conventional system. The high pressure burner helps to avoid combustion problems such as pulsing, sooting and poor ignition, which might otherwise occur when pressures inside the combustion chamber fluctuate. Also, the heat exchanger and chimney system will remain relatively free of soot build-up, eliminating the need for annual cleaning of these components.

### **SEALED VENT**

The removal of the barometric damper is the primary reason why the pressures will fluctuate more than normal inside the combustion chamber. A barometric damper normally operates like a relief valve so that when the chimney is hot or high winds are present, the extra draft in the vent won't interfere with the efficiency and performance of the burner. Without the barometric damper, the venting system is tighter and safer, costs less to

operate and keeps the chimney warmer and drier. Therefore, removing the damper and sealing any other openings in the flue is a good idea as long as the burner can withstand the pressure fluctuations and the appliance is certified for such use. Contact the manufacturer, if necessary, for specific information and instructions.

### **STAINLESS STEEL CHIMNEY LINER**

A stainless steel chimney liner is another way of keeping the flue warmer and drier. The steel liner heats up quickly and prevents the products of combustion from condensing for long periods on the mass of cold masonry materials that makes up most chimneys. Consequently, the chimney will be more durable and should be free of major condensation damage and subsequent repairs for many years.

A steel liner also reduces the volume and exposed area inside the chimney. This permits a reduction in the firing rate for the appliance, further improving the efficiency of the system. Moreover, most masonry chimneys are already oversized (relative to firing rates) and the flow of combustion products is thus inadequate to keep the top of the chimney warm enough to avoid condensation. By reducing the total volume of the chimney, liners also restrict the flow of gas when the burner is operating, and thus assist in moderating pressure fluctuations (preventing excessive draft).

### **CHIMNEY INSULATION**

The insulation around a chimney liner helps the chimney stay warm during and after each operating cycle. A warmer chimney, decreases the possibility of serious condensation problems, such as ice blockages, water drainage problems, and freeze-thaw damage to brick and tile.

### **WIND RESISTANT CHIMNEY CAP**

A wind resistant chimney cap makes all winds increase the chimney draft, even if the wind is trying to blow down into the chimney, and it prevents high winds from creating too much draft in the chimney. Without a cap, the wind-induced chimney draft may exceed even the pressure tolerances of the high-performance burners.

### **CERAMIC LINER**

The ceramic liner is a wet cloth of glass fibre that is wrapped inside a steel combustion chamber. After a few minutes of burner firing, the glass fibre becomes a hard, 1 inch (25mm) thick insulating layer of ceramic. This layer of ceramic is necessary to protect the back and sides of a combustion chamber from overheating due to the higher temperatures created by the high pressure burner. High pressure burners can create firebox temperatures of 2268 F (1260 C), too hot for the steel used in the heating appliance.

In some cases a liner is not essential. For example, if the steel combustion chamber is comprised of the water jacket of a boiler, no liner is necessary due to the greater cooling ability of the chamber.

**FIGURE B.5**

**Sealed Chimney Liner in Combination with High Pressure Oil Burner**

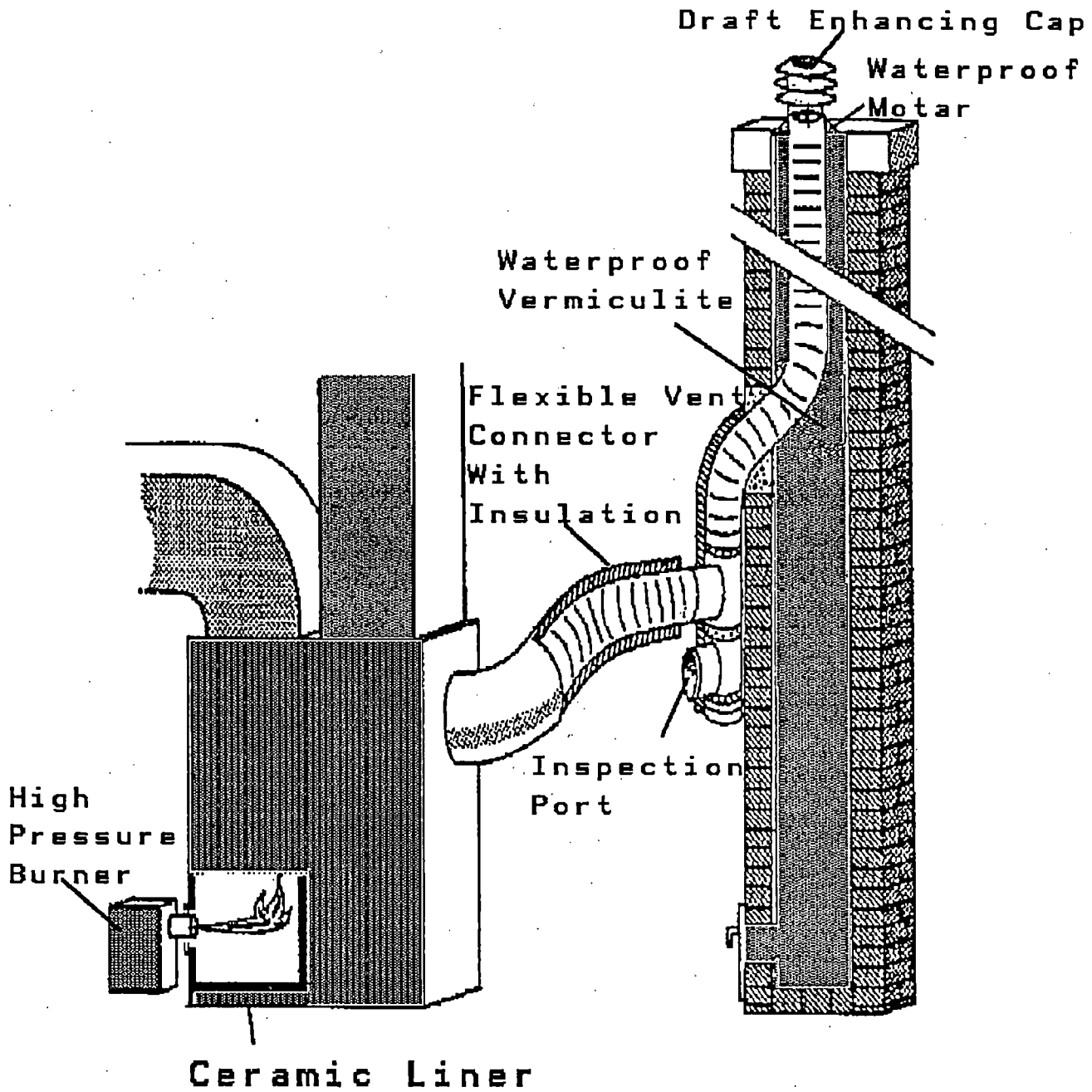

## **WHEN TO RECOMMEND A HIGH-PRESSURE BURNER AND A SEALED AND INSULATED VENTING SYSTEM**

The installation of a high-pressure burner and a sealed and insulated venting system is worth considering in any home where the existing oil furnace or boiler is expected to operate for the next 10 years or more. It is especially suitable for houses in cold climates, where fuel bills are high and where chimneys tend to have more trouble from condensation.

The retrofitted system will permit safe venting of oil appliances with house depressurization up to 0.04 in. W.C.(10 Pa.). Thus, the system is appropriate for houses with persistent sooting and odour problems due to back-drafting and start-up spillage.

Tall chimneys and chimneys on exterior walls are very susceptible to condensation and draft problems and will, therefore, benefit from lining and insulation.

Chimneys with evidence of existing moisture problems are especially good candidates. The new chimney caps will eliminate entry of precipitation and the insulated liner should remedy:

- \* icing;
- \* drainage problems (look for signs of leakage and efflorescence on the exterior of the brick, near the base of the chimney);
- \* moisture damage (interior paint peeling, wood rot next to chimney); and
- \* masonry damage (spalling, loss of mortar, broken tile caps, broken liner pieces in ash clean-out).

The high cost of these measures may be an obstacle for many householders. In addition to the initial investment of about \$1,300, the householder must be prepared to pay for an annual inspection of the burner and replacement of the oil line filters.

Installation of a new burner in oil furnaces with an expected life of less than 5 years is not recommended.

### **B.10 Improved Vent Connectors for DHW Appliances**

Most Canadian homes have a single flue venting from the basement area to above the roof-line. If both the furnace and domestic hot water (DHW) heater are fuel-fired appliances, chances are they will have joined vent connectors, yet often the DHW is included in the venting system only as an afterthought - a mistake, because proper venting of the DHW is just as important as that for the furnace.

By improving the design and installation of the vent connectors or shared flues it is possible to reduce the chances of a venting problem. Improvements should be considered whenever a new appliance or a chimney is

being installed (or replaced) and whenever problems are encountered with pressure-induced spillage from DHW heaters.

## **DESIGN FEATURES AND MATERIALS**

A key feature for effective venting of the furnace and DHW is minimizing the restrictions in each vent connector. This involves determining the best location for the appliance, the best method of joining the vent connectors and using the best materials.

The DHW heater is considered to be a weaker appliance than the furnace because it has to operate during the summer, when chimney draft is very poor. For this reason, the DHW should be given priority in its proximity to the chimney. The shorter the length of the DHW vent pipe, the better, but it is also important to minimize the number of elbows. Therefore, the DHW should be placed so that it will have the shortest, straightest run to the chimney or furnace vent connector as is possible.

The preferred method for merging the furnace and DHW vent connectors is with a "Y" fitting. This gives the least flow resistance, but if extra elbows are required to lead to the "Y" then it may be better to use a more resistive "T" fitting and avoid the elbows.

In the case of a masonry chimney, there is no significant difference to venting performance between a "T" fitting on the vent connector or a direct fitting to the chimney.

When choosing the materials for the DHW vent connector, the installer should consider the configuration to be used. If elbows are unavoidable, the least resistance is incurred if the elbow has a large number of segments and a large radius. If an awkward or twisted run is unavoidable then a flexible vent pipe is preferable over using a straight pipe with several elbows.

Before using a flexible pipe, check with local authorities regarding approved use. Normally, a flexible vent connector is acceptable if the connection to the B-vent or masonry chimney is in accordance with approved practice. Flex-pipe connectors have the advantage of easy installation and airtight construction, however they will need more frequent braces than straight pipe.

Finally, with a shared flue system it is crucial that there be little resistance to flow downstream (up the chimney) of the connection. This helps to avoid short-circuiting, wherein the products of combustion from one appliance rise part way up the vent connector and then flow back into the house through the other vent connector and appliance.

### **B.11 DEALING WITH LEAKY HEAT EXCHANGERS**

In most cases, the heat exchanger should be replaced if it is defective and the balance of the furnace is in very good condition. This is usually the case only when the heat exchanger has prematurely failed. In the majority of cases, a furnace with a cracked heat exchanger should be replaced with a new furnace.