



FOREWORD

Criteria for the Design, Fabrication, Supply, Installation, and Acceptance Testing of Walk-In, Radio-Frequency-Shielded Enclosures (CID/09/12B) is an unclassified publication, issued on the authority of the Chief, Communications Security Establishment (CSE).

This document is effective upon receipt, and replaces document CID/09/12, dated 1986.

Suggestions for amendments should be forwarded to CSE by Government of Canada (Government) users through departmental channels, and by industrial users through Public Works and Government Services Canada (PWGSC).

This publication is for use by Government departments and agencies, and by authorized qualified contractors that have responsibility for providing radio-frequency-shielded (RF-shielded) enclosures to Government and/or to industrial users in support of Government contracts.

The criteria contained herein are for general application to RF-shielded rooms. To ensure that unique customer requirements are addressed, the customer or its contracting authority shall be consulted for additional guidance.

S. Gauthier
Director General, ITS
Communications Security Establishment

TABLE OF CONTENTS

LIST OF ABBREVIATIONS AND ACRONYMS	ix
1.0 INTRODUCTION	1
1.1 Purpose	1
1.2 Scope	1
1.3 Application	1
1.4 Design, Construction and Installation Objectives.....	2
1.5 Applicable Documents	2
1.6 Comments and Recommendations	3
2.0 GENERAL SPECIFICATIONS.....	5
2.1 Design Requirements.....	5
2.2 Performance Requirements.....	5
2.3 Shop Drawings.....	6
2.4 Work Included in Contract	6
2.5 Warranty.....	7
2.6 Periodic Re-Testing of Shielding Effectiveness.....	7
3.0 ENCLOSURE SPECIFICATIONS.....	9
3.1 General.....	9
3.2 Shielding	9
3.3 Doors.....	9
3.4 Waveguides Below Cut-Off.....	12
3.5 Ventilation Air Entries	12
3.6 Service Penetrations	13
3.7 Filters.....	14
3.8 RF Connectors for Shielding-effectiveness Testing.....	19
3.9 Internal Grounding System	20
4.0 FACILITY INSTALLATION	21
4.1 General.....	21
4.2 Location.....	21
4.3 Shield Installation.....	22
4.4 Enclosure Grounding	23
5.0 QUALITY ASSURANCE	24
5.1 Quality Assurance Plan.....	24
5.2 Testing Attenuation Performance.....	26
6.0 MAINTENANCE	27
6.1 General.....	27
6.2 Periodic Inspection and Preventive Maintenance	27

6.3	Corrective Maintenance.....	28
6.4	Records	28

**ANNEX A – SAFETY CONCERNS ASSOCIATED WITH EXPOSURE TO
ELECTROMAGNETIC RADIATION29**

A.1	Introduction	29
A.1.1	Purpose	29
A.1.2	Application.....	29
A.1.3	Referenced Documents	29
A.2	Electromagnetic Radiation Hazards.....	29
A.2.1	Hazards to Personnel.....	30
A.2.2	Hazards to Explosives.....	30
A.2.3	Hazards to Fuel.....	30
A.3	Electromagnetic Energy Exposure Limits For Personnel.....	31
A.3.1	Health and Welfare Canada	31
A.3.2	American National Standards Institute	31
A.3.3	American Conference of Government Industrial Hygienists.....	32
A.4	Safety Recommendations For Testing Shielded Enclosures.....	34
A.4.1	Maximum Recommended Exposure Levels	34
A.4.2	Maximum Recommended Power Levels	35
A.4.3	Recommended Detection Systems.....	37

**ANNEX B – ACCEPTANCE TESTING OF RADIO-FREQUENCY-SHIELDED
ENCLOSURES39**

B.1	Introduction	39
B.1.1	Scope	39
B.1.2	Applicable Documents	39
B.2	Instrumentation For The Testing Of Shielding Effectiveness	39
B.2.1	General.....	39
B.2.2	Signal Source	39
B.2.3	Attenuator.....	40
B.2.4	Source Antennas.....	40
B.2.5	Receiving Antennas	40
B.2.6	Detection System.....	40
B.2.7	Dynamic Range.....	41
B.2.8	Stability.....	41
B.2.9	Frequency Accuracy	41
B.2.10	Amplitude Accuracy.....	41
B.2.11	Calibration.....	41

B.3	Shielding-Effectiveness Performance Requirements	41
B.4	Shielding-Effectiveness Test Procedures	42
B.4.1	General	42
B.4.2	Test Procedures	43
B.4.3	Test Locations	44
B.4.4	Safety	44
B.5	Other Test And Inspection Procedures	45
B.5.1	Electrical Isolation Testing	45
B.5.2	Door and Interlock Operation	45
B.6	Quality Assurance Tests And Inspections	45
B.6.1	General	45
B.6.2	Responsibility for Tests and Inspections	45
B.6.3	Government Witness	45
B.6.4	Preliminary Testing	46
B.6.5	Acceptance Test & Inspection Plan.....	46
B.6.6	Acceptance Test & Inspection Report.....	47
 ANNEX C – TYPICAL POWER LINE CONFIGURATIONS.....		57
C.1	Universal Considerations	57
C.2	Typical Configurations	57

LIST OF ABBREVIATIONS AND ACRONYMS

ACGIH	American Conference of Government Industrial Hygienists
ANSI	American National Standards Institute
COMSEC	communications security
CSE	Communications Security Establishment
CW	continuous wave
dB	decibels
DCA	Departmental COMSEC Authority
DSO	Departmental Security Officer
EED	electro-explosive device
EMR	electromagnetic radiation
ET	transmitted electric field
Government	Government of Canada
HT	transmitted magnetic field
ICSD	Industrial Corporate Security Directorate
PCW	pulsed continuous wave
PWGSC	Public Works and Government Services Canada
Q.A. Plan	Quality Assurance Plan
RF	radio frequency
RF-shielded	radio-frequency-shielded
SAR	specific absorption rates
VSWR	voltage standing wave ratio
Witness	Government Witness

1.0 INTRODUCTION

1.1 Purpose

This document provides general specifications, as well as technical implementation details, for the provision of a walk-in, radio-frequency-shielded (RF-shielded) enclosure constructed to contain electromagnetic radiation emanating from equipment located within the enclosure.

Application of this document to shielded cabinets, shielded rack assemblies, and/or small shielded enclosures shall be approved by Communications Security Establishment (CSE) on a case-by-case basis.

1.2 Scope

This document covers requirements and specifications applicable to the: design acceptance; supply; installation; and acceptance testing, of a walk-in, RF-shielded enclosure. The enclosure and any auxiliary facilities furnished as part of its complete installation shall:

- attenuate electromagnetic radiation in accordance with the requirements specified in Section 2.2, Performance Requirements, and Table I;
- filter all power and signal lines that penetrate the enclosure;
- include all electrical wiring required by the enclosure;
- include lighting and air conditioning of the enclosure;
- include all flooring, as well as floor and wall coverings, of the enclosure; and
- provide an enclosure of which the shielding effectiveness will not be degraded by any other required penetration through its surfaces (floor, ceiling and/or walls).

1.3 Application

It is recommended that this document be considered to contain the minimum contractual specifications for the procurement, acceptance testing, and continued maintenance inspecting of an RF-shielded enclosure.

In addition, it should be noted that these specifications do not preclude the application of additional performance specifications to meet specific needs. It is therefore recommended that each Government of Canada (Government) department or agency obtain the advice of its responsible Departmental COMSEC Authority (DCA) before modifying any specification found in this document. It is also recommended that the DCA review the contractual requirements for each installation prior to calling for tenders.

Industry users shall obtain guidance from Public Works and Government Services Canada (PWGSC) prior to contract, if modifications are desired.

Note: Failure to obtain such guidance might result in the disapproval of the installation.

1.4 Design, Construction and Installation Objectives

The ability to maintain continuously high attenuation characteristics shall be stressed throughout design, construction, and installation. The following objectives shall be met.

- a. **Attenuation.** The enclosure shall provide electrical, magnetic, and plane-wave attenuation, equal to or greater than that specified in Section 2.2, Performance Requirements, and in Table I, when all line filters are installed (carrying 25 per cent of their rated current), and all internal air ducts are in place.
- b. **Durability.** Since the enclosure will be subjected to: varying floor loads; the repetitious use of access doors; possible disassembly and re-assembly; and, in most cases, continuous use of its air conditioner and filters, all components of the enclosure, its accessories and ancillary equipment shall be able to withstand such usage without loss of strength or effectiveness.
- c. **Modularity.** Unless de-mountable construction is excluded by the contract, the structure shall be constructed and assembled so as to make re-assembly possible with a minimum of effort, and with minimum distortion to the room structure.

Particular attention shall be paid to affixing electrical services and other internal accessories to the walls, floors and ceilings of the enclosure by methods that allow easy removal prior to dismantling, and that allow re-assembly of the enclosure without loss in either function or shielding effectiveness.

- d. **Compliance.** The enclosure shall be designed, fabricated, installed and performance tested in accordance with subsequent sections of this document.

1.5 Applicable Documents

The versions of the following standards that are in effect on the date of the invitation for bids shall form part of this document. In the event of a conflict, the requirements of this document shall take precedence.

MIL-STD-202F	<i>Test Methods for Electronic and Electrical Component Parts.</i>
MIL-STD-220	<i>Method of Insertion Loss Measurement.</i> 1988-09-19.
IEEE- STD -299	<i>Standard Method for measuring the effectiveness of Electromagnetic Shielded Enclosures.</i> 1997-12-09.
MIL-F-15733	<i>Filters, Radio Interference, General Specification for.</i>
MIL-STD-45662	<i>Calibration System Requirements (replaced by ISO–10012-1: Quality Assurance Requirements for Measuring Equipment, Part 1: Metrological Confirmation for Measuring Equipment First Edition (1993), and ANSI/NCIL Z540-1-1994: Calibration Laboratories and Measuring and Test Equipment General Requirements (1994)).</i>
ANSI C95-1	<i>Safety Levels with respect to Human Exposure to Radio frequency Electromagnetic Fields: 3 kHz to 300 GHz.</i> Revised 1997.
ANSI/UL-1283	<i>Standard for Safety, Electromagnetic Interference Filters.</i> 1998.
“Safety Code 6”	<i>Limits of Exposure to Radio frequency Fields at Frequencies from 10 kHz–300 GHz.</i>

1.6 Comments and Recommendations

Revisions to this document will be made as appropriate. Comments, including corrections and recommendations regarding content, are encouraged.

Government organizations should submit comments to their responsible DCAs, who may then submit comments to:

Manager, Industrial Programs
Communications Security Establishment

P.O. Box 9703
Terminal
Ottawa, Ontario K1G 3Z4.

Industry users should submit comments to their representatives at PWGSC.

2.0 GENERAL SPECIFICATIONS

Included in this section are: a general description of the work to be completed; performance requirements; shop drawing requirements; and warranty and continued re-testing requirements.

2.1 Design Requirements

The design requirement is to provide an RF-shielded enclosure for the area indicated on associated drawings supplied by the customer.

- a. **Penetrations.** All penetrations of the shielded enclosure (to accommodate power lines, signal lines, control lines, coolant/water pipes, etc.) must be grouped according to function, and installed in such a way that the overall performance of the shield is not degraded.

Room for expansion at the above locations should be considered in the initial design, in case additional penetrations need to be added during the life of the enclosure.

2.2 Performance Requirements

- a. **Attenuation.** The completed RF-shielded enclosure, with all penetrations and services in place, must attenuate electromagnetic energy in accordance with Table I, when tested using the procedures of Annex B.

Table I – Electromagnetic Attenuation Required

Frequency	Field Component	Minimum Attenuation
10 kHz	Magnetic	55 dB
200 kHz	Magnetic	95 dB
1 MHz	Magnetic	100 dB
400 MHz	Plane-wave	100 dB
1 GHz	Plane-wave	100 dB
10 GHz	Plane-wave	100 dB

- b. **Electrical isolation.** The entire RF shield, with: all fittings in place; all the electrical leads disconnected from their respective filters; and the ground lead disconnected, shall exhibit an electrical isolation from the building ground network of 10,000 ohms minimum, when measured with a DC ohmmeter.

2.3 Shop Drawings

Shop drawings shall be submitted in accordance with Paragraph 5.1.b, Shop drawings, for approval of the DCA, prior to the fabrication or installation of materials.

The shop drawings shall show: the plan; elevations; sections; door details; grounding; penetrations; filters; and any other details that will affect the work of other trades in, or adjacent to, the shielded enclosure.

At the first opportunity after the approval of the shop drawings, the shielding Contractor shall verify all pertinent measurements and conditions of the parent space, by inspection and measurement.

2.4 Work Included in Contract

The shielding Contractor shall: 1) provide all tools, rigging and scaffolding, test equipment, etc. required to construct and test the shielded enclosure; and 2) supply and install all materials and fixtures necessary to construct the enclosure.

Supply and installation shall include, but not necessarily be confined to, the following:

- all of the shielded panels necessary to construct the walls, floor and ceiling (including framing members, supports, fasteners, hangers, related panel stiffeners, etc.), and any brackets and plywood backboards necessary to attach equipment to the shield walls;
- all auxiliary fittings (brackets, clips, etc.) necessary to support the shielding from the parent structure;
- provision for the suspension of all architectural, mechanical and electrical interior items normally hung from a ceiling;
- all door entries (as factory fabricated modules, complete with matching frames and door hardware, and prepared for attachment to the shield panelling);
- all air ventilation duct penetrations (with flexible connectors and air-transfer shielded openings);
- all electrical filters (power, lighting, control, signal, telephone, communications, etc.), including protective devices and discharge safety resistors, where specified;
- all RF-shielded wireways and conduit that connect filters to the shield;
- all penetrations for pneumatic control lines for mechanical equipment;
- all penetrations for plumbing lines;

- electronic locks (with all interconnecting wiring and associated filters) for use in access control of the shielded enclosure;

Note: Electronic locks are not always required. Verify with customer.

- insulators, grounding bus bars and inter-cabling necessary to construct an isolated, single-point grounding system within the shield;
- a single-entry plate (complete with all fused penetration fittings); and
- RF-bulkhead connectors and connector caps (to facilitate shielding effectiveness testing).

2.5 Warranty

The Contractor shall provide a written warranty to the Owner stating that the enclosure will maintain its shielding effectiveness for not less than five (5) years after acceptance.

- Contractor's responsibility.** The Contractor shall be responsible for the repair or replacement of any part or parts that reduce the shielding effectiveness to less than that specified in this document.
- Exclusions.** Degradation of shielding effectiveness due to: abuse; normal wear and tear; and/or modifications to the accepted configuration shall not be the responsibility of the Contractor.

2.6 Periodic Re-Testing of Shielding Effectiveness

- Government Owner.** For a Government Owner, it is **recommended** that the Contractor or a Government test team perform a shielding-effectiveness re-test (in accordance with Annex B, with 400 MHz plane-wave as the minimum standard) at least every five years. DCAs may require that these re-tests and inspections occur more frequently.
- Industrial Owner.** For an industrial Owner, it is **required** that a shielding-effectiveness re-test (in accordance with Annex B, with 400 MHz plane-wave as the minimum standard) be performed by the Contractor at five-year intervals after the original acceptance testing has been successfully completed. The re-test shall utilize all the test parameters specified in the original acceptance test.

If modifications have been made to the enclosure, testing shall be more extensive, incorporating test frequencies in addition to the 400 MHz plane-wave re-test. The scope of the additional tests required shall depend upon the types and number of modifications made to the enclosure. (PWGSC [ITSD] can provide guidance on this subject.) A new Acceptance Test & Acceptance Plan shall be submitted for approval (see Section 5.0, Quality Assurance).

PWGSC shall then be notified of the approved re-test's schedule, at least 30 days prior to the re-test. A complete testing of all parameters specified in the new Acceptance Test & Inspection Plan shall also be performed and recorded **prior to the arrival** of a Government Witness (Witness) (see Annex B, Section B.6.3, Government Witness) at the scheduled re-test. This Witness will verify the shielding effectiveness of representative test points (as selected by the Witness). The successful completion of this re-test will re-certify the enclosure's shielding effectiveness for an additional three-year period.

3.0 ENCLOSURE SPECIFICATIONS

3.1 General

- a. **Site preparation.** The site where the shielded enclosure is to be installed shall be prepared such that a hard, clean surface (free of moisture, dirt and carpeting) is provided.
- b. **Shield floor underlay.** Moisture-resistant, 3 mm hardboard shall be used. The use of 3 mm plastic sheeting with anti-oxidant characteristics is also acceptable.
- c. **Backboard supports.** Where required, 20 mm fir plywood panels (or equal-strength, non-conductive material designed with brackets, stiffeners and fasteners) shall be used. The attachment of backing panels to the inside of the shield is allowable, provided that tamper-proof bolts are inserted from the outer side of the shield.

3.2 Shielding

- a. **Shield panels.** Standard 1200 x 2400 mm or 1200 x 3000 mm panels of rigid wood-product sheets faced with zinc-treated sheet steel shall be used for the walls, floor and ceiling. All panel edges shall be treated to resist moisture absorption.
- b. **Clamp-style framing system.** The panel framing system shall consist of zinc-treated steel members that clamp and rigidly retain the panels either in an edge-to-edge configuration, or in a right-angle arrangement. The steel framing shall use screw-type fasteners, and shall be capable of achieving the pressure necessary between the framing and the panels to achieve the required attenuation.
- c. **Other shielding methods.** A full description (complete with shielding-effectiveness test documentation) of any other proposed shielding method shall be included with the work proposal, for review by the Government Owner and/or PWGSC.

3.3 Doors

- a. **General.** Doors shall be designed for frequent use, and when closed shall sustain the required shield attenuation performance.

Doors shall be: of the hinged, swinging variety; provided with frames as factory-produced modules; and prepared for insertion into the shield opening using a clamp-style framing system (see Paragraph 3.2.b, Clamp-style framing system). Suitable hinging and operating hardware shall be provided with the door modules.

Each double-leaf door module shall have an active leaf and an inactive leaf. The inactive leaf shall be held in the closed position by “head” and “foot” bolts (H.B.Ives Model 0454 or equivalent). The active leaf shall have a latching mechanism as is typical for a manually operated or power-driven door assembly. The active leaf and the inactive leaf shall each utilize RF-sealing fingers, as described in the following paragraph.

Electromagnetic sealing between the perimeter of a door leaf and its mating frame shall be accomplished by the use of beryllium copper contact fingers. One or two concentric rings of these fingers (as required to achieve the necessary attenuation performance of the closed door) shall be attached to either the door leaf, or to the door frame. The fingers shall be protected from accidental damage, and shall be attached in such a manner that they can be readily replaced using normal hand tools.

The RF-shielded enclosure shall be designed in such a way that when the doors are opened, they cause minimal stress to the shielding panels upon which they are mounted.

- b. **Emergency doors.** Emergency/equipment-entry doors (whether single-leaf or double-leaf) shall be provided with emergency (“panic”) hardware on the shielded side of the door. This hardware shall be of a type acceptable to the Owner. There shall be no means of operating the dual-latch-point door-latching mechanism from the outer side of the door.
- c. **Manually operated doors.** Each manually operated door shall be fitted with a mechanical-advantage-type latch that uses a minimum of two latch points on the door frame. An operating handle on each side of the door leaf shall provide easy latching and unlatching of the door, without requiring excessive force. Access shall be provided for repair and maintenance of the mechanism.
- d. **Power-activated doors.** Each power-activated door shall be equipped with both a power-operated latcher and a power-operated opener/closer, with the two units system-connected to open or close the door leaf on the command of a trip switch (for example, an electronic lock, a foot mat, an electronic eye, or a manual switch). If a person triggers the trip switch, the door shall close at a “creeping” or “feather touch” rate that will alert the person to step out of the way of the swinging door.

The operating sequence shall be as described below.

1. On receipt of the signal from the trip switch, the door latcher shall unseal the door leaf from its frame.
2. When the door leaf is free from the frame, electronic control shall pass to the opener/closer, which shall then fully open the door.

3. The door leaf shall pause at its fully open position for a period of time (up to 10 seconds) that can be internally adjusted.
4. Unless prevented by the triggered trip switch, the door shall be closed by the opener/closer, and sealed into place by the latcher.
5. The total elapsed time for opening and closing (if not interrupted by the operation of the trip switch) shall not exceed 20 seconds. This shall be adjustable to a shorter time interval.

Both the latcher and the opener/closer shall: operate under the positive control of an electric motor (and not depend on any hydraulic, pneumatic or spring device); operate from a 120 VAC/60 Hz, 15A connection mounted on a breaker panel fitted to the door frame head; and be suitable for the intended environment (including room air pressure of +75 Pa to -75 Pa).

The latcher and/or the opener/closer shall not restrain the opening of the door during an electrical power failure. The latcher shall be fitted with an emergency release lever, which in turn shall be equipped with a lockable restraint. **The key for the restraint shall be kept outside the shield, in the known custody of an on-site authority.** The latcher shall be equipped with a sequence counter (to assist in maintenance).

The door shall be fitted with an alarm that registers when the door is open and is being restrained from closing (whether by the action of the trip switch, or by a physical obstruction). There shall be a time delay of between 30 and 60 seconds before the alarm sounds.

If the door is the active leaf of a double-leaf door, the inactive leaf shall be equipped with a non-contacting magnetic switch, so that if the inactive leaf is not properly closed and sealed, the active leaf will not be operable, and will be held in the fully open position with the alarm operating. There shall be provision on the physically secure side of the door for a key-operated disabling switch that will permit both the active leaf and the inactive leaf to remain open for an indefinite period without the alarm sounding. The active leaf shall open automatically by the operation of the switch.

- e. **Doors at RF-shielded lockways.** RF-shielded lockway entrances (referred to as RF lockways, RF vestibules or RF sluices) are recommended if an enclosure door is to be opened “often” (that is, more than 4% of the operational time and/or more than 10 times per hour). An RF lockway is designed to ensure that the RF shield is continuous at all times when personnel enter or leave the enclosure. There are two doors, one at each end of a lockway.

The exterior of each door (that is, as viewed before entering the lockway) shall be equipped with a colored “traffic” light to indicate that the unseen door is open (or not properly closed).

The doors shall swing outwards from the lockway, and shall be electrically wired such that there is an effective interlock ensuring that only one door can be open at a time. The interlock must be fail-safe in the event of a power failure.

A spring-loaded emergency switch (mounted inside the enclosure, 1.5m above the floor and clearly visible and suitably labelled) shall permit emergency opening of both personnel doors at any time. It shall hold the doors open until the system is restored (by a reset switch located on the outside of the enclosure).

It is recommended that the doors be power operated; in the case of a double-leaf door, the active leaf shall be power-operated.

3.4 Waveguides Below Cut-Off

The frequency below which RF energy is attenuated by a waveguide is generally calculated based on an air medium filling the volume of the waveguide. Should material other than air (for example, plastic, glass or fibre) be used to fill a significant portion of waveguide volume, the cut-off frequency might be dramatically below that calculated for air. This could cause an enclosure to fail the 10-GHz shielding-effectiveness test.

Consequently, careful selection of the materials used in protective cable jackets and in dielectrics is necessary in order to eliminate this potential problem.

Note: The waveguide-beyond-cut-off principle only applies to non-metallic cables and devices (for example, fibre optic cables). Under **no** circumstances shall **metallic conductors** (coaxial cable, data communication wiring or cables) be passed through a waveguide mounted on a shielded enclosure, as it would reduce the shielding effectiveness of the enclosure to an unacceptable level.

3.5 Ventilation Air Entries

- a. **General.** Each RF-shielded air vent shall be a metallic, cellular, “honeycomb-style” waveguide-beyond-cut-off structure, with unit cells of maximum opening diameter and minimum length, such that it sustains the required attenuation when properly inserted into a shielding panel.

The air pressure drop across each shielded air vent shall not exceed 30 Pa, at an air velocity of 7 m/sec.

- b. **Connections to ductwork.** Each shielded air vent mounted to a shielding panel for connection to the ductwork shall be fitted with a 25-mm-deep sheetmetal collar. Each shielded air vent and its collar shall be suitably protected from corrosion. The vent shall also be equipped with a non-conductive flexible collar outside the enclosure, in order to ensure that the building ductwork is electrically isolated from the shielded room.
- c. **RF-lockways.** When an RF-lockway arrangement exists, 250mm x 250mm RF-shielded transfer vents shall be provided in both of the doors.

3.6 Service Penetrations

- a. **Single-entry plate.** It is recommended that, whenever possible, all service penetrations of the enclosure (for fibre optics, filtered data communication, water, AC power, etc.) take place through a single-entry plate on the enclosure, rather than spreading the penetrations around the periphery of the unit. This will dramatically reduce the possibility of radio frequency ground loops being generated.

All piping and electrical conduit penetrations of the RF-shielded enclosure shall occur at the single-entry plate. The penetrations shall be grouped as close together as is practical (that is, minimizing the separation between individual pipes), and each penetration shall be suitably fused to the single-entry plate. A dielectric union shall be inserted within 1m of the entry point of each conduit/pipe on the outside of the enclosure.

- b. **Penetration materials.** In order to preserve the electrical isolation of the shield, each pipe and conduit shall utilize either an isolation coupling, or a dielectric union. The dielectric union shall be utilized: 1) on that portion of the pipe/conduit immediately adjacent to its penetration of the shield; and 2) at its external connection to the shield. (PVC pipe may be used where service considerations and authorities permit).

Piping and conduit from filters (see 3.7, Filters) shall penetrate the shield only through the use of threaded pipe nipples that are inserted into holes in the shield and secured firmly by faced flange nuts designed to ensure proper RF sealing with the shielding panel. The nipples shall be of suitable material (steel nipples shall be zinc plated) and proper IPS size for each service. Pipe threads shall be "dry seal" TYPE 1, N.P.T.F., and no lubrication of any type shall be permitted.

Each pneumatic control line shall have a short section of non-conductive plastic tubing inserted at its penetration of the shield. This plastic tubing shall enter the shield through a waveguide-beyond-cut-off fixture that provides 100 dB attenuation at 10 GHz.

Note: The Contractor shall ensure that **no** coil spring or other metal device is inserted into the plastic tubing as an anti-kink device, because such metallic devices would compromise shielding effectiveness (see cautionary note in Section 3.4, Waveguides Below Cut-Off).

- c. **Fire extinguisher piping.** Piping installed for fire extinguishing purposes shall be of the “dry pipe” design. (The goal is to have the pipe clear of water except during a fire emergency.)

Note: Failure to meet this requirement could result in failure to meet the electrical isolation specification of Paragraph 2.2.b, under Performance Requirements.

3.7 Filters

- a. **General.** All electrical conductors (for power and lighting, controls and signals, telephone, communications, fire suppression, etc.), shall be fitted with filters and transient suppressers that preserve the RF-shielding performance of the enclosure.

All filters shall meet the requirements of this section (3.7, Filters) detailing the performance requirements of each type of filter.

The use of fibre-optic cable (channelled through waveguide-beyond-cut-off fixtures) to replace wire-line (signal, telephone and communications) filters wherever possible is **highly recommended**. Vendor and configuration guidance should be obtained from PWGSC or the responsible DCA.

All filters shall be mounted either directly on the shielded panels, or on backboards. Attaching filter cabinets, closets, etc. to the shield enclosure by ferrous conduit shall **not** be permitted except by agreement of the Owner.

- b. **Power line filters.** Power line filters may either be: 1) individual units for each conductor (including neutral) arranged for direct mounting on the shield; or 2) a grouping of all the filters for a feeder, contained inside a compartmented and shielded cabinet mounted in accordance with the preceding paragraph.

When individual unit power line filters are used, all filter cases should mate with the shielded room walls stressing maximum electrical zoning between the filter case and the wall.

Replacement of a faulty filter unit shall be readily achievable by a qualified electrician, and the resulting installation shall not degrade shield performance.

Power line filter construction standards

In general, each power line filter shall conform to the construction standards of ANSI/UL-1283. The following standards shall also apply:

- Finish: Paragraph 3.4.2 of MIL-F-15733

- Threaded Parts: Paragraph 3.4.3 of MIL-F-15733
- Terminal Strength: Paragraph 3.15 of MIL-F-15733

Filter terminals or leads shall not be an integral part of, or directly connected to, a filter's electrical components.

If liquid fillers are used, then each filter shall be adequately sealed to prevent leakage under any conditions of usage, including normal installation procedures.

In order to provide transient protection, each filter shall be fitted at each end with a properly rated metal-oxide varistor transient protector for voltage spikes. For effective protection, the varistor shall be fitted to the filter terminals in such a way that its lead length between filter terminal and filter case is kept to a minimum. (A total lead length of 3cm is recommended.) The varistors shall allow normal operation of the filters with voltage sags and surges during normal usage, but shall curtail line voltage spikes.

The Contractor shall specify filter manufacturer(s), along with part numbers, at the submission of shop drawings. (Sample units may be required, at the discretion of the Owner.)

The following information shall be clearly and permanently inscribed on the body of each filter, and shall also be included in the Test Report (see "Power line filter tests," below):

- serial number, with no number repeated for any model;
- impedance magnitude (measured at 60 Hz, with no load on the unit); and
- DC Insulation Resistance, from terminal to case.

Note: The above information might be utilized during an on-site, abbreviated inspection of all units delivered. Any significant discrepancy from the nameplate data may result in rejection of a unit for use on the shield..

Power line filter performance requirements

Power line filters shall reduce conducted RF signals from either direction (that is, they shall have bi-directional attenuation properties). However, the filters only need to demonstrate attenuation compliance in the direction that ensures emanations from the shielded enclosure do not appear on AC mains feeding the enclosure.

Each filter may be supplied in any convenient rating that meets the requirements of its intended application. It shall be suitable for operation in the following electrical power systems (as applicable):

- 120 VAC 60 Hz 1-Phase
- 120/208 VAC 60 Hz 3-Phase
- 220 VAC 60 Hz 3-Phase Delta
- 347/600 VAC 60 Hz 3-Phase
- up to 600 VDC.

Each filter shall exhibit: 1) temperature rise characteristics that meet the requirements of Paragraph 25 of ANSI/UL-1283; 2) dielectric voltage-withstand characteristics that meet the requirements of Paragraph 26 of ANSI/UL-1283; and 3) a voltage drop no greater than that acceptable for its intended application, when tested in accordance with MIL-F-15733. The voltage drop shall not have any impact on the operation of the equipment inside the enclosure at full load and with a unity power factor.

(Note: The following accelerated-life test may be specified, at the option of the project's Design Authority: When operated for 48 hours at 150% of voltage rating, and with a 0.9% lagging P.F. load of 200% of rating, with free air access to all of its surfaces except its mounting face, the filter shall evidence no signs of physical or electrical damage, including sealant leakage.)

Each filter shall exhibit the following stop band attenuation characteristics.

- The minimum insertion loss from 10%–100% rated loads shall be 100 dB over the frequency range from 14 kHz–10 GHz.

(Note: An extended-range buffer network is required to fulfil the 14 kHz–10 GHz insertion loss required.)

Measurements shall be made using the procedures defined in MIL-STD-220 under "Load Conditions," except that the impedance of the buffer network shall be at least 200% greater than that of the filter under test, when making the insertion-loss test at 14 kHz.

- Alternatively, the performance of filters under load may be verified by measuring the linearity of all inductors used in the filters. (The equipment and procedures used must be approved by the DCA prior to testing.) Measurements shall be made at 10%, 50% and 100% of rated load, over the frequency range of 14 kHz–20 MHz. Insertion loss shall not be less than 100 dB.

If the above inductor linearity verification procedure is being used, measurements shall be made at 0%, 10%, 50% and 100% of rated load. Total inductance variation of all inductors used in any single filter shall not exceed 2% of the no-load inductance value.

- Additional insertion loss measurements shall be made from 20 MHz–10 GHz, in accordance with MIL-STD-220.

Power line filter tests

A test report of the proposed power line filters shall be submitted with the Contractor's proposal, to support the claim that the filters comply with the requirements of this section (3.7, Filters). The Contractor shall describe the test laboratory's calibration traceability to Canadian, U.S. or other national primary standards, and a professional engineer shall certify the report. (If such a report is not available, or if additional acceptance testing is required as stated in the contract, see the following paragraph.)

If specified in the contract, or if the above-mentioned test report is not available, one unit of each model of power line filter used in the installation shall be acceptance tested in accordance with this section, on a cost-recovery basis. The results of the testing shall be immediately conveyed to the Owner for review and approval. The Owner shall then forward the test results to the responsible COMSEC (communications security) engineering authority for approval. If the filter's performance is acceptable, the enclosure Contractor will be notified by PWGSC, and the filter(s) will be returned to the Owner for retention as a spare unit(s).

Note: Failure of a filter unit to meet the requirements of this section might result in the rejection of the entire quantity of filter units in that particular shipment.

c. Communications/Control line filters.

Note: The use of optical isolators in place of lowpass lumped constant filters wherever possible is strongly recommended (see Paragraph 3.7.f, Optical isolators and high-data-rate circuits).

Filters for control or signal wires that penetrate the enclosure may either be: 1) individual units directly mounted to the shield; or 2) contained inside a cabinet.

If a cabinet is used, it shall be two-compartmented to create a shielded section and an unshielded section, with a shielding barrier between. There shall be suitable access covers to each area of the cabinet, with the "shielded" area's cover fitted with an RF gasket (or other suitable device) that preserves the overall shielding integrity of the installation.

The cabinet may be mounted directly to the shield wall, or it may be remotely located. If the cabinet is remotely located, the conduit or RF wireways connecting the cabinet to the shield penetration shall have a length-to-diameter ratio not greater than 5:1.

The cabinet shall be equipped with wire-wrap telephone blocks (to permit easy wiring for external connections). Inter-wiring between each filter unit and its terminal block shall be by insulated TW wire, sized according to the filter's current rating. All corrodible materials and electrical contact surfaces shall be suitably protected, consistent with their use.

Communications/Control line filter construction standards

The filter units shall conform to the construction standards detailed in Section 3.7.b for power line filters, except that the following standards shall take precedence:

- Case: Paragraph 3.4.1 of MIL-F-15733
- Overload: Paragraph 3.14 of MIL-F-15733.
- Transient Protection: (not required unless otherwise specified)

Communications/Control line filter performance requirements

The filter units shall conform to the performance requirements detailed in Section 3.7.b for power line filters, except that the following standards shall take precedence.

Each filter shall be suitable for the electrical system in which it is intended to be used. Typical ratings (provided for reference purposes) include:

- 24–120 VAC 60 Hz
- 24–150 VDC

Each filter shall be capable of meeting a DC voltage test of 1000 volts for a period of one minute without incurring damage, in accordance with Paragraph 4.6.5 of MIL-F-15733 (except for the magnitude of the test voltage).

Each filter unit, when tested in accordance with Paragraph 4.6.8 of MIL-F-15733, shall not have a voltage drop that would hinder the operation of the intended equipment when the system's full current load is applied.

The minimum stop band attenuation provided by each filter unit shall not be less than 100 dB from 14 kHz–10 GHz.

- d. **Fire alarm suppression and detection filters.** Each filter shall conform to the requirements for communications/control line filters, as specified in Section 3.7.c.

- e. **Voice-frequency and low-speed-data filters.** Individual filter sections shall meet all the requirements set out in Paragraphs 3.7.a–d, plus the following additional requirements: the filters shall be constructed as matched pairs, contoured on one sealed metal housing for use on balanced 600 ohm lines (for example, Western Electric KS-20162). Each side of the balanced line shall be filtered.

Filters may be designed for direct mounting on the surface of a single-entry plate, or they may be arranged as a group within a shielded cabinet (as described above in 3.7.b, Power line filters). If a shielded cabinet is used, a cross-connection diagram (or book) shall be provided in a suitable holder within the line side of the cabinet.

- f. **Optical isolators and high-data-rate circuits.** As mentioned above, the use of fibre-optic isolation devices for penetrating the shielded enclosure is highly recommended for data lines and control signal lines, because the waveguides-beyond-cut-off principle can be employed with glass or plastic optical cables penetrating the shielded enclosure wall.

Fibre-optic links presently available can handle synchronous and asynchronous digital data from 50 bits–500 Mbits/sec. Analogue video fibre links are available with bandwidths extending up to 1 GHz.

Note: The waveguides-beyond-cut-off principle does **not** apply to metallic conductors. Passing any metallic conductor (including a metallic reinforcing wire within an optical cable bundle) through a waveguide poses a severe shielding-integrity hazard, and shall **not** be allowed.

3.8 RF Connectors for Shielding-effectiveness Testing

TYPE UG-30/U radio frequency “N” bulkhead (female/female) feed-through connectors and male caps (Allied Amphenol part number MX-913, or equivalent) shall be fitted to the enclosure, in order to facilitate shielding-effectiveness testing. The connectors shall be left capped when not in use.

- a. **Usable range.** The connectors shall be usable at up to 10 GHz, and shall present a voltage standing wave ratio (VSWR) of no more than 1.3 at 10 GHz.
- b. **Number required.** If an enclosure’s largest dimension (width or height) does not exceed 6m, only one connector on the single-entry plate shall be required. For a larger enclosure, one connector shall be required for every 5m of wall width and every 3m (storey) of wall height. The connectors shall be installed in the wall panels, at least 0.5m but not more than 2m above the floor or storey level.

3.9 Internal Grounding System

The installation of AC power in a shielded enclosure shall employ the use of an isolated “green” safety ground wire from **each** receptacle or outlet to the electrical panel. This special internal grounding system shall be electrically isolated, everywhere except at its single-point connection to the shield’s grounding stud.

4.0 FACILITY INSTALLATION

4.1 General

The site where the shielded enclosure is to be installed shall be inspected before commencing installation, and any unacceptable conditions shall be reported to the Owner.

The site shall be prepared such that a hard clean surface (free of moisture, dirt and carpeting) is provided.

Start of installation shall constitute acceptance of site conditions.

4.2 Location

A shielded enclosure constructed to contain electronic processing equipment used to process classified information shall be physically located in a controlled space approved by the Departmental Security Officer (DSO).

- a. **Secure access.** The shielded enclosure shall be protected by whatever means necessary to ensure that access to the immediate area around the enclosure cannot be made by unescorted, uncleared personnel. In some instances this might require a gypsum wallboard room to be constructed around the enclosure, from the true ceiling to the true floor of the area.
- b. **Minimizing shielding weak points.** Placing the enclosure inside a parent room can minimize potential weak points in shielding. Since access doors are potentially the weakest points (in terms of shielding effectiveness) in an enclosure, they should be located close to the centre of the control zone, where leakage will be least detectable. In addition, since each penetration of the enclosure presents a possible leakage point, the enclosure should be located where the fewest penetrations will be necessary.
- c. **Physical deterioration.** The location should be selected so as to minimize (it will be unlikely that it can be eliminated) thermal cycling, humidity cycling, vibration, shock, etc., which might degrade the shielding performance of the enclosure with age.

Shielded enclosures are particularly vulnerable (in terms of the degradation of shielding performance) to water. A location therefore should be selected that does not have condensation problems. (Condensation problems can result where changes of humidity occur near cold water pipes, air conditioners and chillers, etc.)

- d. **Obstructions.** The enclosure should be located where few pipes, ducts, etc. will interfere with construction.

4.3 Shield Installation

Installation shall be performed by, or under the supervision of, trained factory personnel. Workmanship shall be consistent with the highest standards for the industry.

- a. **Isolation preserved.** All contact with the parent structure or slab shall be done in a way that preserves the electrical isolation of the shield. Any wooden blocking shall be treated with wood preservative, and shall have a layer of 6mm white neoprene between the blocking and any metal part of the shield.
- b. **Ground sheeting.** Prior to setting the floor panels, the area shall be covered with a 6 mil layer of "C-I-L DURAFILM 3," or a similar anti-oxidizing plastic sheeting, to provide electrical isolation from the parent area's floor. Other materials may be used if they are capable of providing the required electrical isolation for the shield, and they will not degrade during the expected life of the shielded enclosure.
- c. **Subflooring.** A layer of 3mm moisture-resistant hardboard shall be laid over the anti-oxidizing plastic sheeting, over which the shield shall be constructed.
- d. **Panelling.** Shield panels shall be laid in a straight line, with true and level surface.
- e. **Ohmmeter.** A relay-alarm ohmmeter shall be connected between the first-laid panel and either the nearest grounded metal building structure, or the nearest "green" electrical ground. The device shall be set to alarm at a resistance value of 20,000 ohms.

The relay-alarm ohmmeter **shall be connected at all times** during the installation period (including during any subsequent work by other trades), up to the acceptance testing of the completed installation.

If it is not practical to leave the ohmmeter connected (because of equipment or power tool usage), then it may be disconnected, but it shall remain in place. The Owner's representative, together with the installation supervisor, shall then re-connect the ohmmeter three times daily, and record the isolation value in ohms in the appropriate log book.

If at any time the electrical isolation falls below the required value for the installation, or if there is significant change from a previous reading, **all installation work must cease** until the reason has been cleared, or declared acceptable to the Owner.

- f. **Wall reinforcement.** If the shop drawings show reinforcement of any shield wall panelling, it shall be reinforced on the external side of the vertical wall panel joints with tubular (or other suitable) structural steel sections. These members shall not compromise the shielded performance, and shall be protected against corrosion.
- g. **Ceiling support.** The shield ceiling shall be supported either: from the overhead building structure; or from the independent steel frame that surrounds the shield, and is supported by the floor slab/structure.
- h. **Door openings.** All openings for door modules shall be dimensioned to accommodate the door/frame modules. The modules shall be set plumb and square to ensure the proper operation of doors after their installation. Reinforcing to prevent wall motion during the opening and closing of the doors shall be provided.
- i. **Fittings.** All fittings required to attach equipment, ceilings, etc., to the shield shall be installed.
- j. **Penetrations.** All mechanical penetrations of the shield shall be installed.
- k. **Filters.** All filters (including fire alarm detection and control filters, as supplied by other sources), filter cabinets, and any conduit connecting these to the shield, along with all necessary penetrations of the enclosure, shall be installed.
- l. **Other items.** All other specified items required for the complete RF-shielded enclosure shall be installed.
- m. **Concealment.** The closing off of openings in the surrounding parent in order to preserve the security of the installed enclosure shall be co-ordinated.

4.4 Enclosure Grounding

The shielded enclosure shall be electrically grounded, for safety purposes. The local electrical code shall determine the gauge of wire required for connecting the “green” hydro ground wire from the electrical supply panel to the single grounding stud on the enclosure.

Note: No other ground leads shall be used.

5.0 QUALITY ASSURANCE

5.1 Quality Assurance Plan

In order to provide assurance that the shielded enclosure's design, installation and testing will meet the requirements of the contract, the Contractor shall submit a series of documents showing how it intends to achieve and verify the quality and performance of the completed shield. These documents together shall make up the contents of a master document, titled *Quality Assurance Plan* (Q.A. Plan).

a. **Contents.** The Q.A. Plan shall be submitted by the Contractor to the Owner, for review and approval, within 10 days of receiving a contract. The Q.A. Plan shall contain the following sections, treated in sufficient detail to enable the engineer acting on behalf of the Owner to properly evaluate the program:

- a title page, with date and identification number;
- a document-revision page;
- an index;
- a discussion containing general information and the aim of the project;
- a schedule of document submissions (including a complete listing of all proposed shop drawings);
- a plan for the submission of all samples;
- materials (including fabricated items) quality-control procedures;
- on-site quality-control procedures;
- an Acceptance Test & Inspection Plan; and
- an Acceptance Test & Inspection Report.

Some elements of the Q.A. Plan are discussed in more detail below.

b. **Shop drawings.** Shop drawings shall be prepared in sufficient detail to permit adequate assessment of the methods of construction, as well as all details (internal layout, shield penetrations, etc.) that might affect shield performance, or the interfacing with other trades. The shop drawing list shall be prepared with a revision column, which shall be kept up to date.

The shop drawings shall be submitted to the Owner for approval before any fabrication or construction of the shield. (The drawings may be submitted to PWGSC [ICSD] for guidance and advice before construction begins.)

Note: One approved set of shop drawings shall be available on the site **at all times** during erection and testing of the shield.

- c. **Submission of samples.** Any requirements for prototype-sample testing shall be identified. A schedule for submitting samples, that will not delay the successful completion of the project, shall be provided.
- d. **Acceptance Test & Inspection Plan.** (This may be simply identified at first submission of the Q.A. Plan, with a date indicated for submission as a stand-alone document.) Two copies of the Acceptance Test & Inspection Plan shall be submitted to the Government Owner or to PWGSC, whichever is applicable, for approval. The cover page shall identify the installation location of the shielded enclosure, and shall bear an identity number and the date.

The Acceptance Test & Inspection Plan shall be prepared in accordance with Annex B. General test procedure requirements are discussed in Section 5.2, Testing Attenuation Performance.

Note: No test or inspection results will be recognized as fulfilling any deliverable requirements of the contract **unless and until** the Acceptance Test & Inspection Plan has been approved, as indicated by the return of one copy with an approval endorsement by the Government Owner or PWGSC (ICSD). This endorsed copy shall be available on site at all times while testing or inspection is being conducted.

In order to prevent any testing delay, it is **required** that the Acceptance Test & Inspection Plan be submitted for approval at least 15 days prior to the contemplated start of any on-site testing or inspection; it is **recommended** that it be submitted at least 30 days prior to such testing or inspection.

- e. **Acceptance Test & Inspection Report.** The final elements in the quality assurance program are: 1) the performance of a witnessed acceptance test, according to the approved Acceptance Test & Inspection Plan; and 2) the submission of two copies of the formal Acceptance Test & Inspection Report to the Government Owner or to PWGSC, whichever is applicable, **no later than 30 days after the last inspection or test.**

This report may be submitted in stages as testing and inspection progresses, if the Contractor so desires. However, the report will **not** be considered to be submitted **until** the final portion has been delivered to the engineer representing the Government Owner or PWGSC.

The formal Acceptance Test & Inspection Report shall contain certified, typed copies of all field-recorded test data sheets, and a section commenting on the results in reference to the requirements. It shall be prepared and submitted in accordance with Annex B.

5.2 Testing Attenuation Performance

In order to properly assess the attenuation performance of the shield, it shall be subjected to a series of illumination tests that will determine its attenuation for various frequencies and fields. All testing shall be carried out in accordance with Annex B.

- a. **Preliminary testing.** Preliminary testing shall be conducted at the completion of the shielding shell. At the conclusion of the preliminary testing, copies of the field-recorded test data sheets shall be given to the Government Witness (see Annex B, Section B.6.3, Government Witness) and to the general Contractor, as assurance that the shield meets the performance criteria at this stage of its construction.

Note: These data sheets do not form part of the Acceptance Test & Inspection Report.

- b. **Final testing/inspections.** Final acceptance testing and the final inspections shall be performed at the completion of all work (including all finishes).

At the conclusion of the Preliminary Test, copies of the field recorded Test Data sheets shall be given to the Government witness, and the general contractor, as an assurance that the shield meets the performance criteria at this stage in the construction. These sheets do not form a part of the Acceptance Test & Inspection Report.

6.0 MAINTENANCE

6.1 General

An RF-shielded enclosure is designed as an integrated facility that will provide special attenuation performance. It is vital that these features be preserved.

Note: Whenever major work (installing new penetrations, changing doors, replacing panels, etc.) is performed, a re-test of the enclosure's shielding effectiveness should be performed.

- a. **Contractor's responsibility.** The contractor shall provide preventive maintenance and service for a period of one year after acceptance of the Acceptance Test & Inspection Report. The entire cost of this maintenance, including any repairs and emergency call-outs, shall be included in the cost estimates that are part of the original contract.
- b. **Exclusions.** Repairs (including the replacement of parts) required as a result of other than normal wear and tear will not be the Contractor's responsibility.
- c. **Hazardous substances.** No carcinogenic or other hazardous substances (for example, carbon tetrachloride, freon) are to be used in the maintenance of the shielded enclosure.

Note: Information on hazardous substances (including appropriate safety precautions) is available from provincial ministries of labour.

6.2 Periodic Inspection and Preventive Maintenance

Periodic inspection and preventive maintenance are required to ensure that the shielded enclosure maintains its shielding effectiveness.

Note: Responsible DCAs may modify the requirements of this section for particular enclosures, based on usage and previous experience.

- a. **Monthly.** The following shall be performed monthly.
 1. Inspect all doors, latches, frames and opener/closers for: wear; loose fasteners; misalignment; broken parts; and improper operation.

Operation should be smooth, and without difficulty. Verify that moving parts such as door handles do not exhibit excessive play. Examine hinges for distortion or binding.

Look for scratches or metal filings (even on the floor) that would indicate wear, or door-alignment problems.

2. Clean and inspect the contact surfaces and contact fingers for each door or hatch, in accordance with the enclosure manufacturer's recommended procedures.
3. Perform any necessary corrective action, in accordance with Sections 2.5, Warranty and 6.3, Corrective Maintenance.

b. **Quarterly.** The following shall be performed every three months.

1. Examine all accessible shielding surfaces (especially the single-entry plate) for undocumented penetrations of the shield and/or damage (including corrosion).
2. Inspect all fittings and equipment for tightness of attachment, and for evidence of damage (including corrosion).
3. Inspect all filters for: insulation leakage; evidence of overheating; and/or evidence of damage to transient suppressors, discharge resistors, etc.
4. Perform any necessary corrective maintenance, in accordance with Sections 2.5, Warranty and 6.3, Corrective Maintenance.

c. **Every five years.** The following inspections and preventive maintenance procedures shall be performed every five years.

1. Perform shielding effectiveness tests, in accordance with Section 2.6, Periodic Re-Testing of Shielding Effectiveness.

6.3 Corrective Maintenance

All repairs shall be performed in accordance with the enclosure manufacturer's recommended procedures. Any deficiencies discovered, along with the corrective maintenance recommended or performed, shall be reported to the Owner.

6.4 Records

All inspections, repairs, adjustments, etc. shall be recorded in a log book maintained at the site in the Owner's possession. Any alterations to the shield or its penetrations shall also be recorded in the log book.

ANNEX A – SAFETY CONCERNS ASSOCIATED WITH EXPOSURE TO ELECTROMAGNETIC RADIATION

A.1 INTRODUCTION

A.1.1 Purpose

The purpose of this annex is to: briefly outline potential health hazards posed by exposure to electromagnetic radiation (EMR); detail the current standards for exposure; and recommend maximum power levels for the testing of shielded enclosures.

A.1.2 Application

It is recommended that this annex be used in conjunction with the Health and Welfare Canada publication titled *Limits of Exposure to Radio frequency Fields at Frequencies from 10 kHz-300 GHz* (also known as “Safety Code 6”).

- a. Safety Code 6 is available from Canada Communications Group Publishing, Ottawa, Ontario K1A 0S9. When ordering, quote catalogue number H46-2-90-160E.
- b. Safety Code 6 is also available on the Internet in PDF format, at:
<http://www.hc.sc.gc.ca/ehp/ehd/catalogue/rp6-pubs/93chd160.pdf>

Note: As the understanding of the effects of exposure to electromagnetic radiation improves, Safety Code 6 is revised; therefore, users are strongly urged to use the latest version.

A.1.3 Referenced Documents

The following documents have also been used in the preparation of this annex.

- a. “RF Radiation Hazards,” by Richard B. Schultz, IIT Research Institute, Annapolis, MD. *Item Magazine*, 1983, Pages 200–204.
- b. *Electromagnetic Radiation Hazards*. U.S. Air Force Technological Order 31Z-10-4, Change 3, 10 February 1978.

A.2 ELECTROMAGNETIC RADIATION HAZARDS

EMR poses hazards to personnel, explosives and flammable substances, as discussed below.

A.2.1 Hazards to Personnel

Temporary or permanent damage—up to and including death—can be caused by EMR.

- a. Biological damage is caused by heating. Skin burns, cataracts and delicate tissue damage can be caused by EMR. In addition, organs with limited ability to dissipate heat (for example, lungs, testicles, liver) may be damaged.
- b. Personnel with cardiac pacemakers may be exposed to an additional hazard: the leads of pacemakers can receive undesired signals that can cause changes in rate, or a suppression of electrical output.
- c. Shielded-enclosure testing personnel should take reasonable precautions to minimize exposure (use the lowest power levels and shortest exposure times possible, maximize distance from transmitting antennas, etc.). Personnel in high-risk categories (pregnant women, those wearing pacemakers, etc.) should be especially careful.

A.2.2 Hazards to Explosives

Explosive devices, especially those which utilize electro-explosive devices (EEDs), can be susceptible to EMR. Therefore, careful co-ordination with authorities responsible for explosives is required before generating electromagnetic fields for test purposes.

- a. EEDs are the electrically initiated primers used to detonate explosives in blasting caps, seat ejectors, demolition charges and military munitions, among other things. The EED is the most sensitive link in an explosive system, and its susceptibility to electromagnetic energy might cause either detonation of the explosive charge, or dudding. The wire leads of an EED can act as an antenna, **even if the leads are shorted**

A.2.3 Hazards to Fuel

Fuel and other volatile substances can be ignited by EMR-induced sparks.

- a. Whether or not ignition is possible depends on: the power density of the emitter; the amount of power received; and the presence of an ignitable fuel-air mixture.
- b. *Electromagnetic Radiation Hazards* (U.S. Air Force Technological Order 31Z-10-4, Change 3, 10 February 1978) considers any peak power density of 5W/cm² or less to be safe. (Its recommendation is based upon worst-case-scenario laboratory conditions).

A.3 ELECTROMAGNETIC ENERGY EXPOSURE LIMITS FOR PERSONNEL

Here are the recommended electromagnetic energy exposure limits provided by: Health and Welfare Canada; American National Standards Institute; and American Conference of Government Industrial Hygienists.

A.3.1 Health and Welfare Canada

Health and Welfare Canada’s “Safety Code 6” states that, for whole- or partial-body exposure to either continuous or modulated electromagnetic radiation of frequencies in the range 10 MHz–300 GHz, the following levels must not be exceeded (when averaged over a one-minute period):

- rms. electric field strength: 60 V/m
- rms. magnetic field strength: 0.16 A/m
- power density: 1 mW/cm².

This limit is shown graphically in Figure 1.

A.3.2 American National Standards Institute

The American National Standards Institute (ANSI) guidelines for whole-body exposure to EMR in the frequency range of 300 kHz–100 GHz (averaged over a six-minute period) are shown in Table II. These limits, in terms of equivalent plane-wave free-power density, are also shown in Figure 1.

The ANSI standard provides for higher exposures if specific absorption rates (SAR) and spatial peak SAR values are within prescribed limits.

Table II – American National Standards Institute (ANSI C95.1 – 1982) Exposure Standard

Frequency Range (MHz)	Power Density (mW/cm ²)
.03-3	100
3-30	900/f ²
30-300	1.0
300-1500	f/300
1500-100,000	5.0

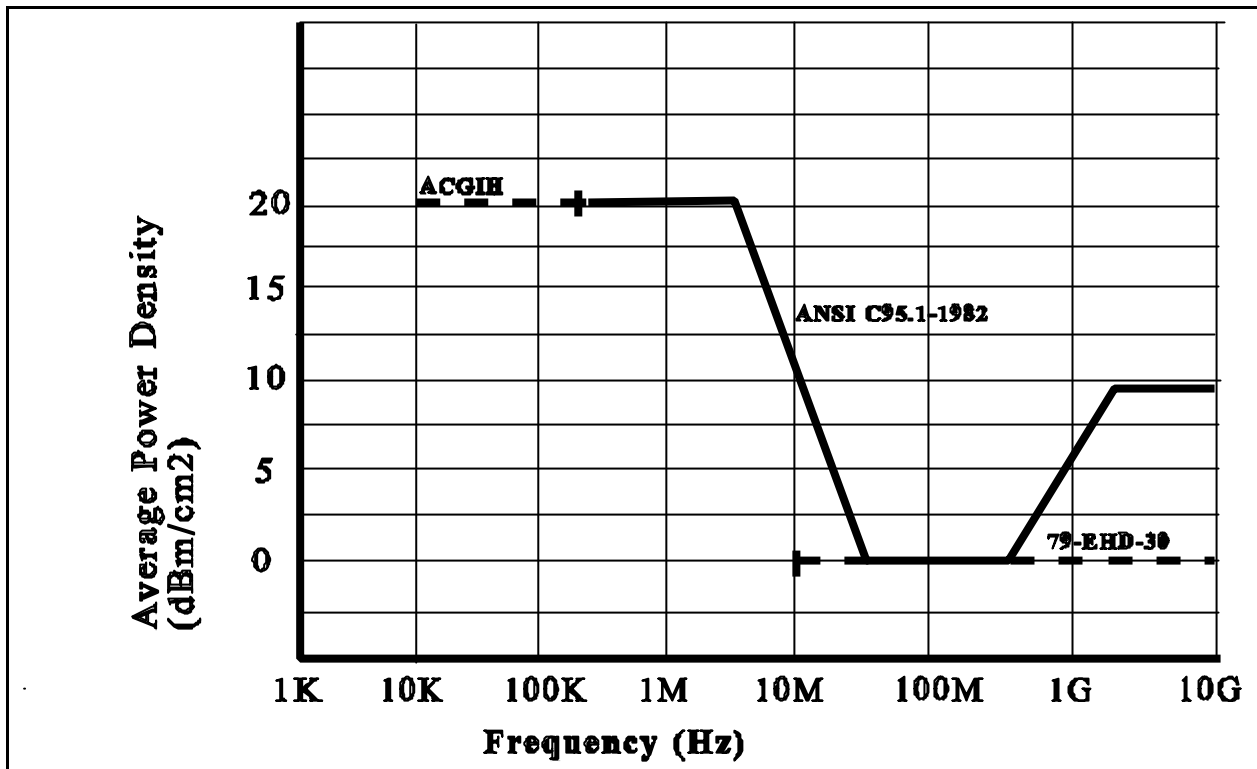

Figure 1 – Guidelines for Personnel Exposure to Electromagnetic Radiation

A.3.3 American Conference of Government Industrial Hygienists

The American Conference of Government Industrial Hygienists (ACGIH) recommends an exposure limit of 100 mW/cm² in the frequency range of 10-300 kHz, in addition to the ANSI guidelines. This limit is also shown in Figure 1.

Notes:

- a. Exposure Limit: Taken from Section A.4.1, Maximum Recommended Exposure Levels.
- b. Transmit Antenna Factors:
 - EMCO 6509 12" passive loop, H field
1 kHz–30 MHz, 50W
 - EMCO 3121 dipole set, E field
20 MHz–1 GHz, 20W
 - EMCO 3115 horn, PW

1 GHz–10 GHz, 300W

- c. Average Transmit Power:

Pa(dBm)

$$= E_T(\text{dB}\mu\text{V/m}) + AF_E(\text{dB}) - 107\text{dB}$$

$$= H_T(\text{dB}\mu\text{A/m}) + AF_H(\text{dB}) - 107\text{dB}$$

where : E_T , H_T are transmitted electric and magnetic field strengths, and
 AF_E , AF_H are the electric and magnetic field antenna factors

- d. Shielding Effectiveness: S.E. from Figure 2.1

- e. Received Field Strength:

$$E_R(\text{dB}\mu\text{V/m}) = E_T(\text{dB}\mu\text{V/m}) - \text{S.E.}(\text{dB})$$

(electric field)<F128M>

$$H_R(\text{dB}\mu\text{A/m}) = E_T(\text{dB}\mu\text{V/m}) - \text{S.E.}(\text{dB})$$

(magnetic field)<F128M>

- f. Receive Antenna Factors: Same as transmit antenna factors

- g. Receive Voltage (at Antenna Terminals):

VR(dB μ V)

$$= E_R(\text{dB}\mu\text{V/m}) - AF_E'(\text{dB})$$

(electric field)

$$= H_R(\text{dB}\mu\text{A/m}) - AF_H'(\text{dB})$$

(magnetic field)

- h. Receiver Noise Figure : Typical for TEK 494AP spectrum analyzer

- i. Received Signal plus Noise-to-Noise Ratio:

S+N/N per paragraph B.107
(dynamic range)

- j. Receive Bandwidth:

$$BW \text{ (dBHz)} = V_R - NF - (S+N/N) + 67 \text{ dB}$$

k. Receive Bandwidth:

$$BW \text{ (Hz)} = 10^{BW(\text{dBHz})/10}$$

(bracketed value is rounded to next lower bandwidth available)

l. Transmit power is limited by the antenna's power-handling capability; allowing for a reasonable safety factor:

- for the EMCO 3121 dipole - 10W = 40dBm
- for the EMCO 3115 horn - 100W = 50dBm

m. The resulting transmitted field is due to limited transmitted power

A.4 SAFETY RECOMMENDATIONS FOR TESTING SHIELDED ENCLOSURES

A.4.1 Maximum Recommended Exposure Levels

As can be seen from the previous section, there is considerable difference of opinion on both the frequency ranges and the radiation levels that are considered safe. It is therefore prudent to use the minimum power levels necessary to perform the required measurements, and to take all reasonable precautions for reducing exposure to electromagnetic fields.

Consequently, the following levels are recommended as the maximum field levels that should be used for testing shielding within the frequency range 10 kHz–10 GHz:

- Electric field strength: (E) 40 V/m(or 152 dBuV/m) rms.
- Magnetic field strength: (H) 0.1 A/m(or 100 dBuA/m) rms.
- Power density: (W) 0.5 mW/cm² (or -3 dBm/cm²) rms.

These levels represent 50 per cent of the lowest levels currently recommended, and were converted to appropriate units using the methodology of Appendix IV of Safety Code 6 (79-EDH-30).

**Table III – Recommended Maximum Power Levels and Bandwidths for Conducting
Shielded Effectiveness Testing**

ON SEPARATE FILE

A.4.2 Maximum Recommended Power Levels

Calculating field strengths. For a 50 ohm system at room temperature (22 degrees Celsius), it can be shown that the transmitted electric field (ET) and transmitted magnetic field (HT) strengths in the far field are given by:

$$ET \text{ (dB}\mu\text{V/m)} = P_a\text{(dBm)} - AFE \text{ (dB)} + 107 \text{ dB}$$

$$HT \text{ (dB}\mu\text{A/m)} = P_a\text{(dBm)} - AFH \text{ (dB)} + 107 \text{ dB}$$

where

ET is the transmitted electric field strength in dB μ V/m

HT is the transmitted magnetic field strength in dB μ V/m

P_a is the average transmitted power over a one-minute period in dBm

AFE is the electric field antenna factor in dB

AFH is the magnetic field antenna factor in dB

Calculating power levels. For continuous wave (CW) sources, the peak and average power levels are identical (in rms. terms). For pulsed continuous wave (PCW) sources, the average power is given by:

$$P_a = P_p \tau$$

where

P_p is the peak transmitted power

τ is the duty factor (that is, time, on per one minute period divided by one minute).(?)

Discussion. The maximum recommended power levels for conducting shielding-effectiveness testing over the range of interest, using typical instrumentation, is shown in Table III.

In the low-frequency magnetic field region, the maximum average transmitted power is limited by the exposure limit. However, for plane-wave testing it is limited more by the A-13 (?) power-handling capabilities of the transmitting antenna.

Experience has shown that testing is easily accomplished in the plane-wave region when using less power than that shown. It should also be noted that transmitted field strengths might be considerably higher than those shown, due to reflections (particularly inside the enclosure).

A.4.3 Recommended Detection Systems

The notes to Table III give the equations necessary to calculate the maximum bandwidths that are required in order to conduct testing, when using a spectrum analyzer (without pre-amplification, and with passive antennas).

It should be noted that the calculations shown neglect any cable losses, which at 10 GHz might be considerable.

Should the bandwidths required be unacceptably narrow, then consideration should be given to using active antennas and/or a receiver preamp to reduce the noise figure. The noise figure of cascaded networks is given by:

$$NF_{ab} = NF_a + [(NF_b - 1)/G_a]$$

where

N_{fab} is the overall noise figure of the cascaded networks

N_{fa} , N_{fb} are the noise figures of the networks a and b

G_a is the gain of network a

For example, if a 20 dB gain preamp with a noise figure of 3 dB were used with a spectrum analyzer with a noise figure of 23 dB, the resulting system noise figure would be 6 dB.

Care should be taken when using wideband preamplifiers to avoid erroneous results due to overload, gain compression, etc. Additional care must be taken to avoid damaging the amplifier.

ANNEX B – ACCEPTANCE TESTING OF RADIO-FREQUENCY-SHIELDED ENCLOSURES

B.1 INTRODUCTION

This annex details the procedures that shall be used to determine the shielding effectiveness, as well as the ground isolation, of an RF-shielded enclosure.

B.1.1 Scope

Testing is divided into the following categories.

Preliminary testing. Testing that is conducted at the completion of the shielding shell, prior to and/or immediately after the installation of finishes, in order to confirm the quality of workmanship prior to formal acceptance testing.

Acceptance testing. Testing that is performed at the completion of the work (including all finishes).

B.1.2 Applicable Documents

The current editions of the following documents form part of this document. In the event of a conflict, the requirements of this document shall take precedence.

Attenuation Measurements for Enclosures, Electromagnetic Shielding for Electronic Test Purposes, Method of. IEEE-STD-299. Replaces MIL-STD-285<T>.

ISO-10012-1 and ANSI/NCSL Z540-1-1994. Replace *Calibration System Requirements*, MIL-STD-45662.

B.2 INSTRUMENTATION FOR THE TESTING OF SHIELDING EFFECTIVENESS

B.2.1 General

This section details the requirements for test equipment used to perform attenuation measurements of an RF-shielded enclosure.

The test equipment shall consist of: a signal source; an attenuator; a source antenna; a receiving antenna; and a detection system. All items shall be unmodified, commercially available equipment.

B.2.2 Signal Source

The electromagnetic signal source may be any signal generator/amplifier combination capable of producing the continuous wave (CW) or pulsed continuous wave (PCW) output power necessary to perform the tests specified herein.

B.2.3 Attenuator

Either an externally calibrated or an internally calibrated attenuator may be used between the receiver and/or transmitter and its antenna(s), in order to determine the attenuation of the enclosure.

B.2.4 Source Antennas

Only the following source antennas shall be used.

- Magnetic fields: loops
- Electric fields: 41" vertical rods
- Plane waves: dipoles or double-ridged horns.

B.2.5 Receiving Antennas

Receiving antennas, whether active or passive, shall meet the requirements.

In addition, broadband magnetic rod antennas (for example, BBH-500) may be used for magnetic field measurements. Broadband electric field and plane-wave antennas (for example, SAS-1) may also be used, subject to prior approval by the Technical Authority.

B.2.6 Detection System

The detection system may consist of any combination of: a receiver; a spectrum analyzer; an amplifier; and/or a field strength meter, that is capable of performing the tests.

The detection system shall provide a visual indication of signal strength. This indicator's response function (whether linear or logarithmic) shall be known. The indicator shall be free of hysteresis, and its response shall appear essentially instantaneous to the operator. Amplitude resolution shall be consistent with the accuracy requirements.

B.2.7 Dynamic Range

The test set-up shall exhibit a dynamic range 6 dB beyond the attenuation requirements of the RF-shielded enclosure.

B.2.8 Stability

The detection system shall retain the recovered signal from the transmitting source within its passband, at a stable and measurable level, for at least twice the projected length of time between reference checks.

B.2.9 Frequency Accuracy

The test equipment shall vary less than +/-10% from the test frequency.

B.2.10 Amplitude Accuracy

The test equipment shall exhibit less than +/- 3 dB total RMS error.

B.2.11 Calibration

The equipment used to measure the attenuation of the shield shall be calibrated in accordance with ISO-10012-1 and ANSI/NCIL 7540-1-1994 at least once every six months, or immediately after exposure to conditions that might affect calibration, whichever is more frequent.

(Note that MIL-STD-45662 has been replaced by ISO-10012-1 and ANSI/NCIL 7540-1-1994.)

B.3 SHIELDING-EFFECTIVENESS PERFORMANCE REQUIREMENTS

Shielding effectiveness, which is the performance criterion of an RF-shielded enclosure, is defined as: the reduction in the amount of electromagnetic energy, when measured in decibels (dB), that results from the introduction of the shield. (This reduction of electromagnetic energy is commonly referred to as attenuation.)

The required levels of shielding effectiveness of an enclosure when tested in accordance with this document shall meet or exceed the limits shown in Figure 2.

Verification of shielding performance shall be limited to spot checks, at the frequencies listed in Table IV.

Table IV – Test Frequencies

Frequency	Component	Attenuation
10 kHz	Magnetic	55 dB
200 kHz	Magnetic	95 dB
1 MHz	Magnetic	100 dB
400 MHz	Plane-wave	100 dB
1 GHz	Plane-wave	100 dB
10 GHz	Plane-wave	100 dB

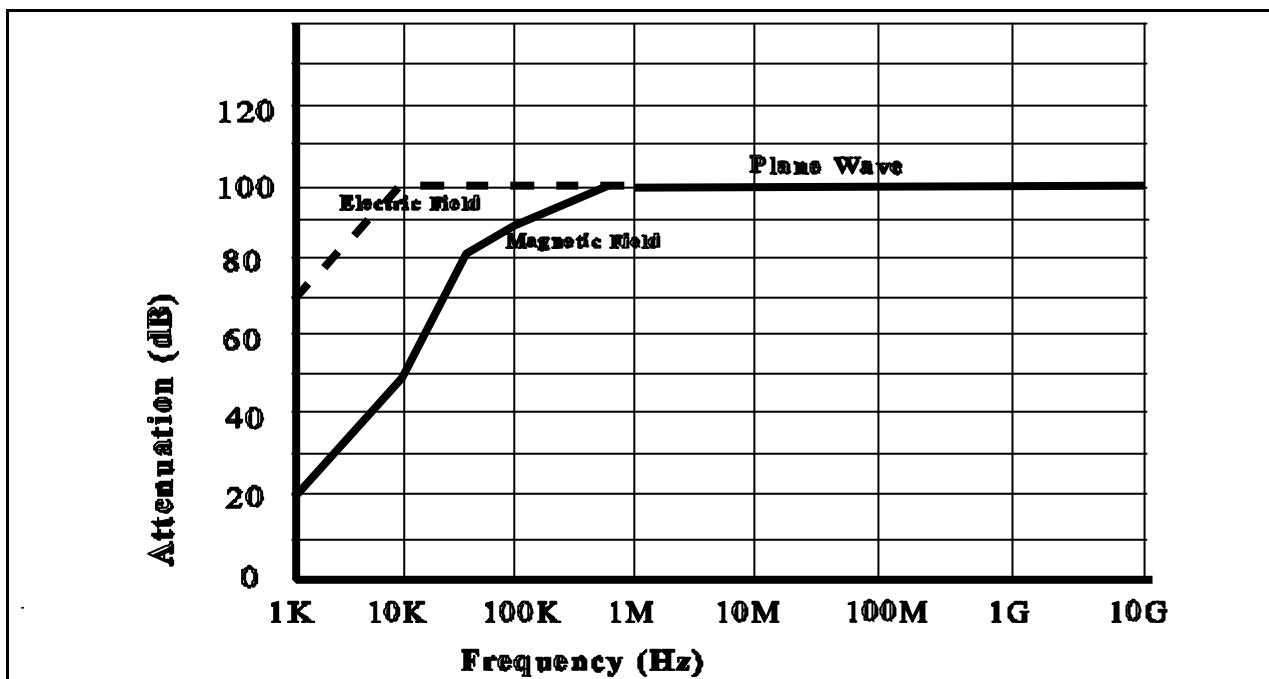

Figure 2 – Electromagnetic Attenuation Required

B.4 SHIELDING-EFFECTIVENESS TEST PROCEDURES

B.4.1 General

This annex details the testing methods that shall be used to evaluate the shielding effectiveness of an enclosure.

During reference measurements, precautions shall be taken to ensure that there is neither case leakage of the receiver, nor saturation of any pre-amplification equipment. In addition, the receiver shall be checked for gain compression (which can cause erroneous readings).

Figures 3 to 9 show equipment arrangements for shielding-effectiveness testing.

B.4.2 Test Procedures

Reference measurement. Prior to taking a shielding-effectiveness measurement, a reference level and a dynamic range shall be established.

1. Both the source antenna and the receiving antenna shall be placed outside the enclosure, and separated as shown in figures 3 to 9. Where it is impractical to use this spacing a shorter distance may be used, provided that the distances from the enclosure wall to the source and receiving antennas are identical.
2. With the source turned off, the received noise level shall be noted. Maximum attenuation shall then be inserted in the signal path, and the source turned on. Attenuation shall be gradually decreased until the received-signal-plus-noise level is at least four times the level of received noise alone (that is, $S+N/N = 6$ dB). (This procedure sets the reference level at least 6 dB above the received noise level.) The attenuation setting shall be noted.

Test point measurement. Once the reference level has been established and recorded, attenuation testing of the enclosure may proceed.

1. The source antenna shall be placed within the RF-shielded enclosure, parallel to the enclosure wall and in the same polarization used to establish the reference level.
2. The receiving antenna shall be placed outside of the enclosure, parallel to the enclosure wall. The distance between the source antenna and the receiving antenna shall be identical to that used to obtain the reference level, and both antennas shall be equidistant from the shielded surface.
3. With the enclosure's doors closed, the source shall be turned on, and the attenuation shall be gradually reduced until the received signal level equals the reference level determined previously. The attenuation setting shall be noted.
4. The difference in attenuation settings between the reference measurement and the test point measurement is the shielding effectiveness.

Verification. Periodic checks shall be made during the reference and test point measurements to verify linearity, correct tuning, and the absence of saturation, gain compression, etc.

Other shielding-effectiveness test procedures. Other test procedures may be used, subject to the prior written approval of the Technical Authority.

B.4.3 Test Locations

Test locations for measuring attenuation shall include the following:

- one point for every 2.5m of wall length, as well as at every wall corner, at the mid-point of every 3m increment of wall height;
- one point for every 10 square metres of ceiling and floor;
- at the central point of the single-entry plate;
- adjacent to every air ventilation port;
- at every door and hatch (including at the inner doors of RF lockways), with one test per door seam (that is, four for single-leaf doors, and seven for double-leaf doors); and
- adjacent to any other penetration not described above.

The total number of test locations may be consolidated where the above requirements produce a close physical duplication.

B4.4 Safety

Every precaution shall be taken to ensure that personnel are not exposed to hazards (particularly electric shock or excessive electromagnetic fields) during the course of testing.

Exposure levels are not to exceed 50 per cent of the limits set by Health and Welfare Canada (see Annex A), unless continuous monitoring of field levels is employed.

B.5 OTHER TEST AND INSPECTION PROCEDURES

B.5.1 Electrical Isolation Testing

The erected shield must be isolated from all grounds (except by the dedicated ground lead).

Monitoring and/or measurements of ground isolation shall be made as directed in Paragraph 4.3.e, Ohmmeter. The ohmmeter shall read at least 100,000 ohms full-scale, and shall be calibrated in accordance with Section B.2.11, Calibration. Results shall be recorded for inclusion in the Acceptance Test & Inspection Report (See Section B.6.6, Acceptance Test & Inspection Report).

B.5.2 Door and Interlock Operation

The operation of all doors (including interlocking systems) shall be demonstrated at the final inspection, with all possible combinations of usage exercised.

Observations shall be recorded for inclusion in the Acceptance Test & Inspection Report.

B.6 QUALITY ASSURANCE TESTS AND INSPECTIONS

B.6.1 General

A series of quality assurance tests and inspections are necessary to provide assurance that the RF-shielded enclosure will meet the required standards over its expected service life.

B.6.2 Responsibility for Tests and Inspections

The shielding Contractor shall be responsible for performing all required tests and inspections, unless otherwise stated. The Contractor shall use its own resources plus other suitable resources for performing said tests and inspections, subject to Government approval.

The Government reserves the right to perform any inspections or tests that it considers appropriate to ensure that the quality of the RF-shielded enclosure meets the necessary standards.

B.6.3 Government Witness

A Government Witness (Witness) appointed by PWGSC (ICSD) shall observe all formal testing and inspections.

Advance notice. The contractor shall notify PWGSC at least 30 days in advance of formal acceptance testing. All field-recorded test data sheets shall be attested to by the Witness.

Extended schedule. For a shielded enclosure that requires an acceptance testing schedule longer than two working days (due to size, etc.), the Witness shall require a demonstration of the test results shown on the preliminary test data sheets, for no more than 10 per cent of the test locations.

Discrepancies. In the event that witnessed results do not correspond with the test data sheets, the Witness shall require additional testing, and possibly enclosure modifications, until the Witness is satisfied that the RF-shielded enclosure meets the performance specifications.

B.6.4 Preliminary Testing

The Contractor shall conduct sufficient preliminary testing to satisfy itself that the shielded enclosure will be ready by the time that final acceptance testing takes place.

At the conclusion of preliminary testing, copies of the field-recorded test data sheets shall be provided to the Witness and to the general Contractor, as assurance that the shield meets the performance criteria specified at that stage of the construction.

B.6.5 Acceptance Test & Inspection Plan

General. Prior to the commencement of any acceptance test or inspection, an Acceptance Test and Inspection Plan shall be submitted and approved (see also Section 5.1.d, Acceptance Test & Inspection Plan).

This document may be prepared in the Contractor's preferred format, unless otherwise specified. It shall detail the Contractor's plan for demonstrating compliance with this Annex, and with any other applicable contractual requirements.

The document shall be provided to the Witness at least 10 working days in advance of the proposed testing. Prior to commencement of any acceptance test or inspection, an Acceptance Testing and Inspection Plan shall be submitted and approved in accordance with paragraphs 406.f. This document may be prepared in the contractor's format unless otherwise specified, and shall detail the contractor's plan for demonstrating compliance with this Annex and any other applicable contractual requirements. This document shall be provided to the Government Witness at least 10 working days in advance of the proposed testing.

Contents. The Acceptance Test & Inspection Plan shall be a stand-alone document containing, but not limited to, the following:

- an identification number, the date of the Plan's submission, and some reference to the name of the project;
- a statement of the contract requirements for testing and inspection;

- a listing of all test personnel, and their qualifications for the testing and inspection of RF-shielding;
- a general statement relating to the conditions under which the testing will be conducted, including work schedules;

Note: No acceptance testing outside of normal daytime working hours shall be acceptable, unless agreed to by the Witness.

- a detailed description of each test or inspection procedure, complete with equipment identification, arrangement and connections (diagrams are mandatory);
- a complete listing of all proposed test equipment, together with their calibration status;

Note: Equipment shall be calibrated in accordance with Section B.2.11, Calibration, and evidence of the date and successful completion of this calibration shall be provided to the Witness.

- drawings showing test point locations, in accordance with the testing and inspection requirements; and

Note: All test points must be identified with either a numeric or an alpha-numeric identifier, for recording purposes and for future identification.

- sample test data sheets for field-recording all test and inspection data.

B.6.6 Acceptance Test & Inspection Report

General. After successful completion of all acceptance tests and inspections, the Contractor shall prepare and submit an Acceptance Test & Inspection Report (see also Section 5.1.e, Acceptance Test & Inspection Report). This document may be prepared in the Contractor's preferred format, unless otherwise specified.

Contents. The Acceptance Test & Inspection Report shall document the results obtained during acceptance testing and inspection. It shall contain, but not be limited to, the following:

- a title page, with a document identification number and the date of its submission, together with a brief description of the project;
- an index;

- general comments referencing the previously submitted quality assurance documentation, and the contract requirement for an Acceptance Test & Inspection Report;
- reference to the Acceptance Test & Inspection Plan, with a copy of the document included in an appendix for reference purposes;
- a section containing certified and typed copies of all field-recorded test data sheets;
- a section containing a commentary on the reported results, as they compare with the required performance;

Note: Any deficiencies shall be clearly identified, with any rationale or argument for the acceptance of less than the required test results clearly expounded upon for the benefit of the Owner and/or PWGSC. Any factors that either prevented or adversely affected the test results shall be identified.

- a list of all test equipment used, with serial numbers and the calibration status of all measuring items; and
- certification that all submitted data and observations are correct, and were obtained in accordance with the approved Acceptance Test & Inspection Plan.

Note: Certification shall be either by the sealed signature of a registered professional engineer, or by the notarization of the signature of the senior technologist present during the testing and inspection.

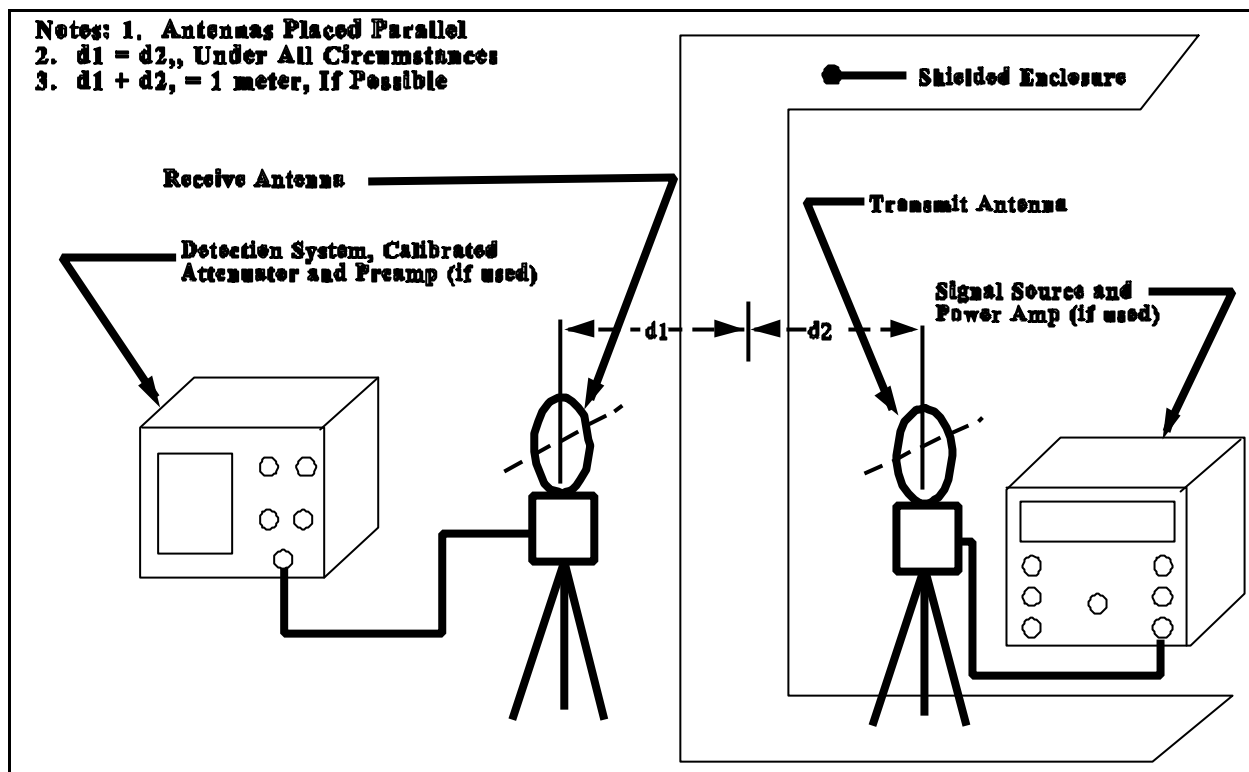

Figure 3 – Test Set-up for Magnetic Field Measurements

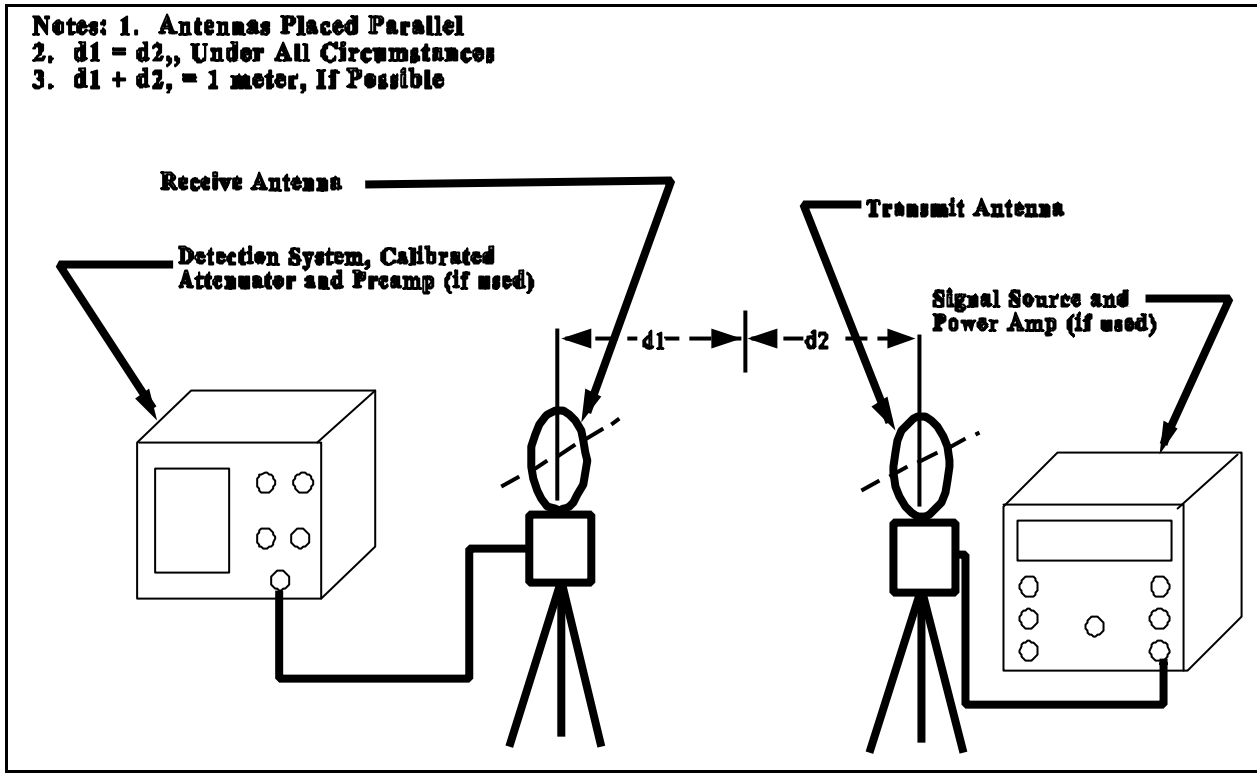

Figure 4 – Test Set-up for Magnetic Field Reference Measurement

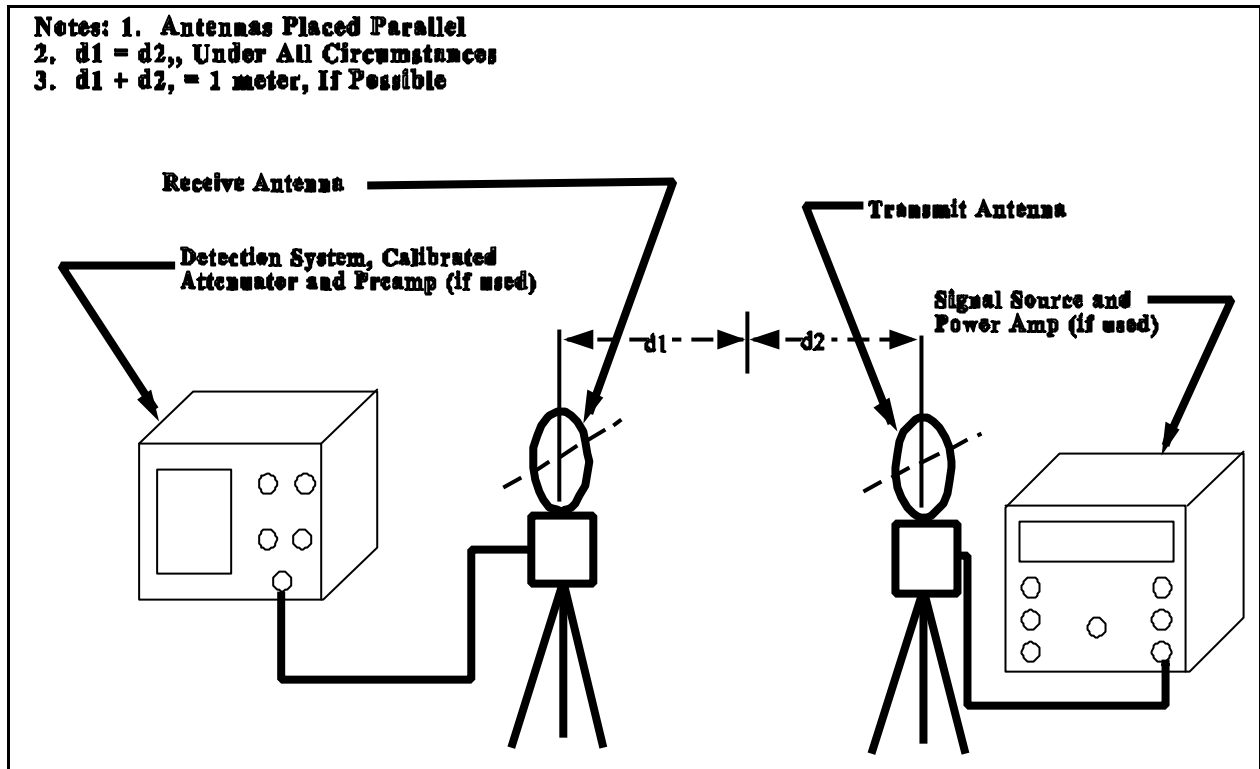

Figure 5 – Test Set-up for Electric Field Measurements

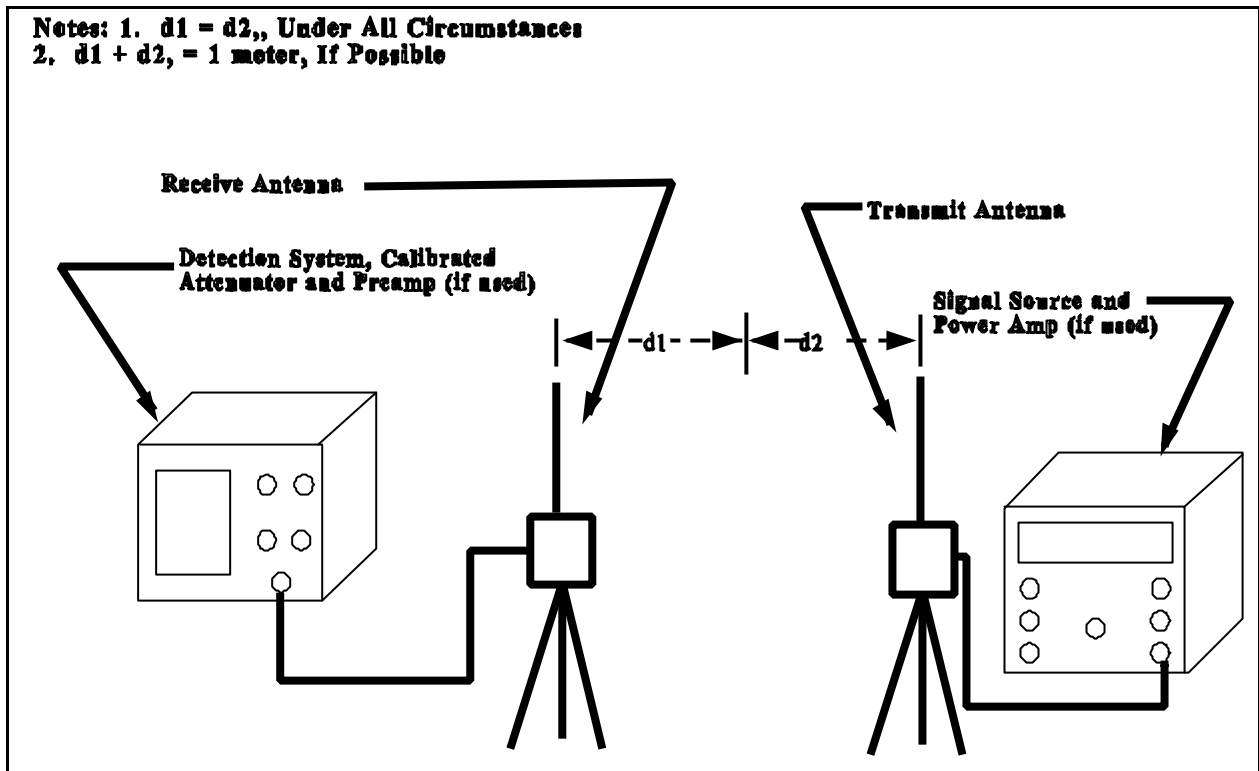

Figure 6 – Test Set-up for Electric Field Reference Measurement

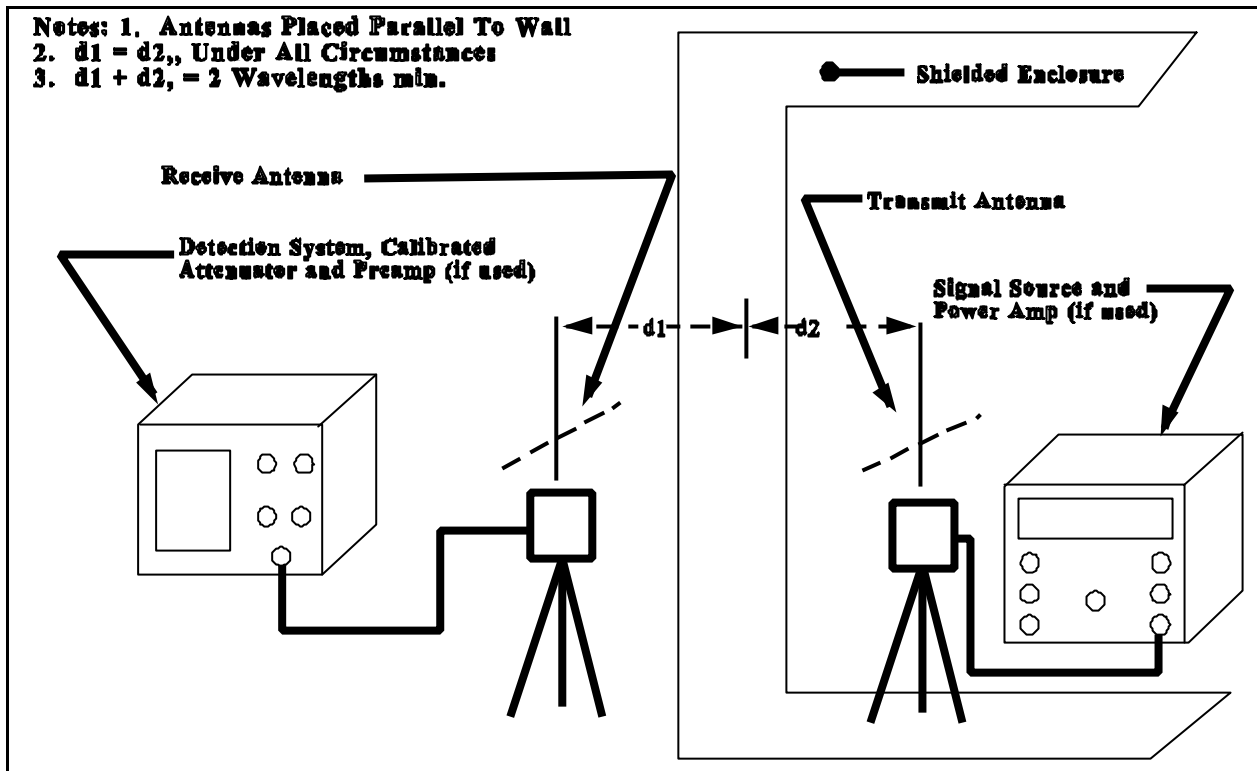

Figure 7 – Test Set-up for Plane-wave Measurement

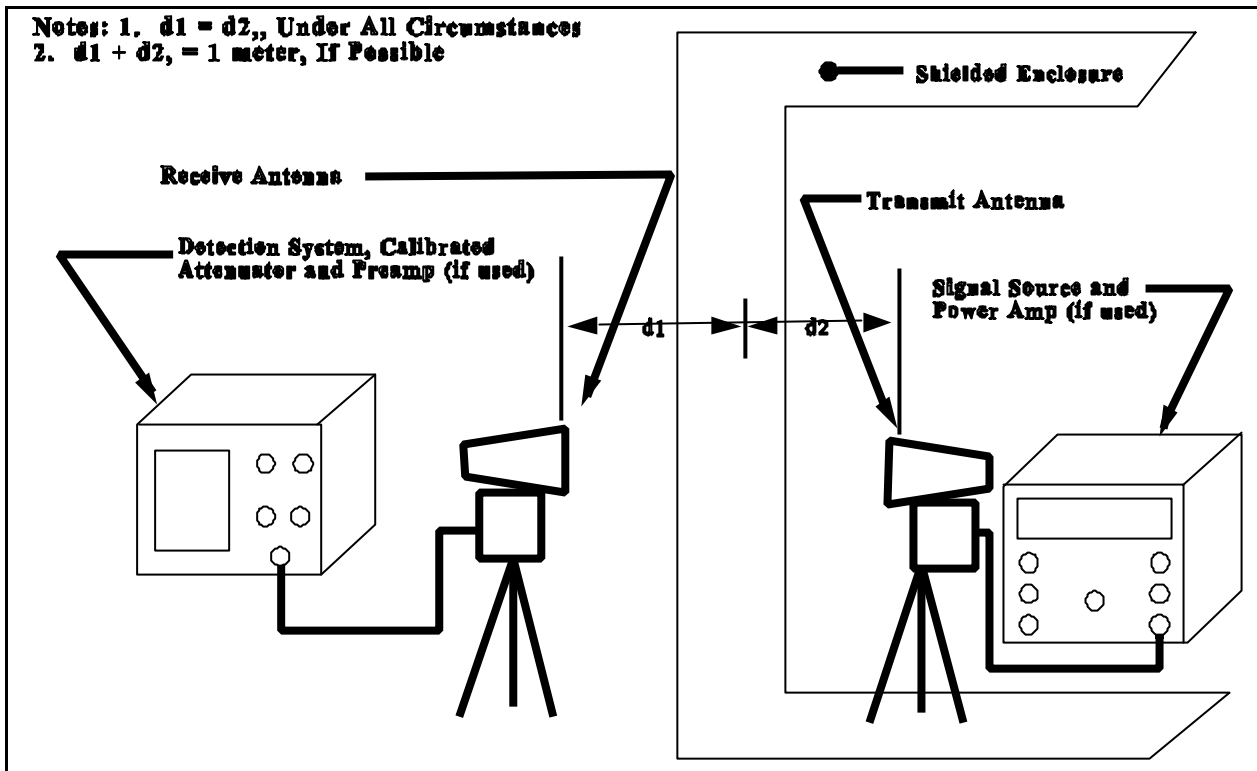

Figure 8 – Test Set-up for Plane-wave Measurement

Notes: 1. $d_1 = d_2$, Under All Circumstances
2. $d_1 + d_2 = 2$ Wavelengths min.

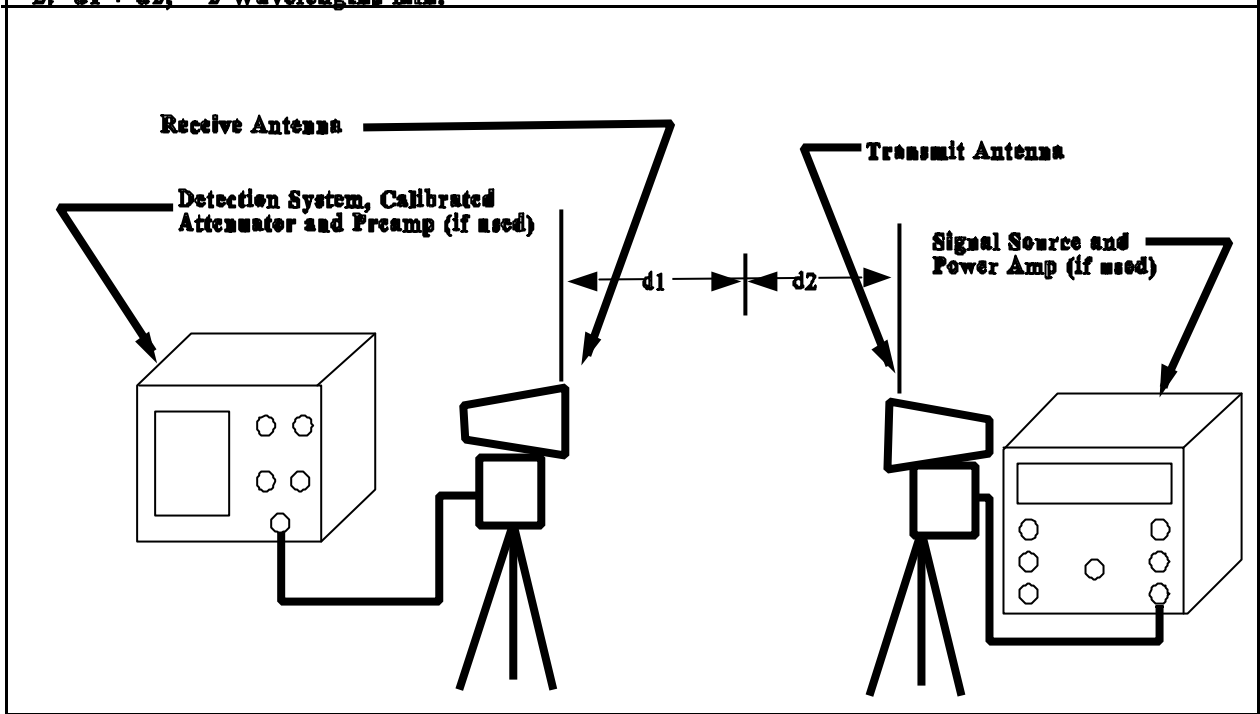

Figure 9 – Test Set-up for Plane-wave Reference Measurement

ANNEX C – TYPICAL POWER LINE CONFIGURATIONS

C.1 UNIVERSAL CONSIDERATIONS

The following should be considered at the planning stage.

- All lines (except safety grounds, but including neutrals) entering the enclosure shall be filtered.
- Neutrals shall be grounded **only** at the facility service entrance.
- The enclosure shall be grounded by connecting the single point grounding stud to the facility service entrance ground.
- Safety grounding inside the enclosure shall be accomplished by using insulated wire connected to the shielded enclosure **only** at the grounding stud.
- All power wiring (including grounds) shall be designed, installed and inspected in accordance with the applicable hydroelectric codes.

C.2 TYPICAL CONFIGURATIONS

The equipment which will be (or may in the future be) installed inside an enclosure determines the power configuration required inside that enclosure. This annex shows typical power line configurations for use with shielded enclosures.

The following configurations are by no means exhaustive, but they do represent configurations in common use.

- 120 VAC 60 Hz 1 phase
- 120/240 VAC 60 Hz 1 phase
- 120/208 VAC 60 Hz 3 phase Wye
- 220 VAC 60 Hz 3 phase Delta
- 347/600 VAC 60 Hz 3 phase Wye
- DC up to 600 V

Schematic diagrams of the above typical power line configurations are shown in Figures 10 to 14.

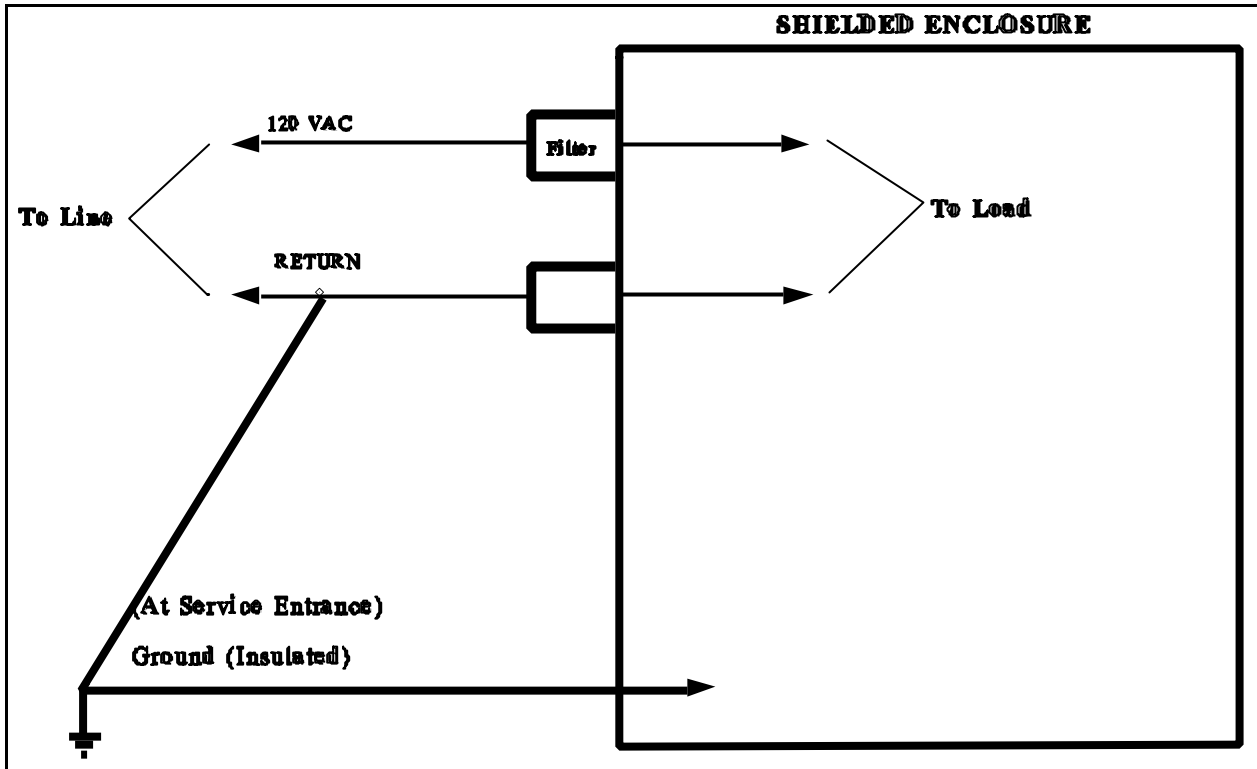

Figure 10 –Typical Power Line Configuration for 120 VAC, Single Phase

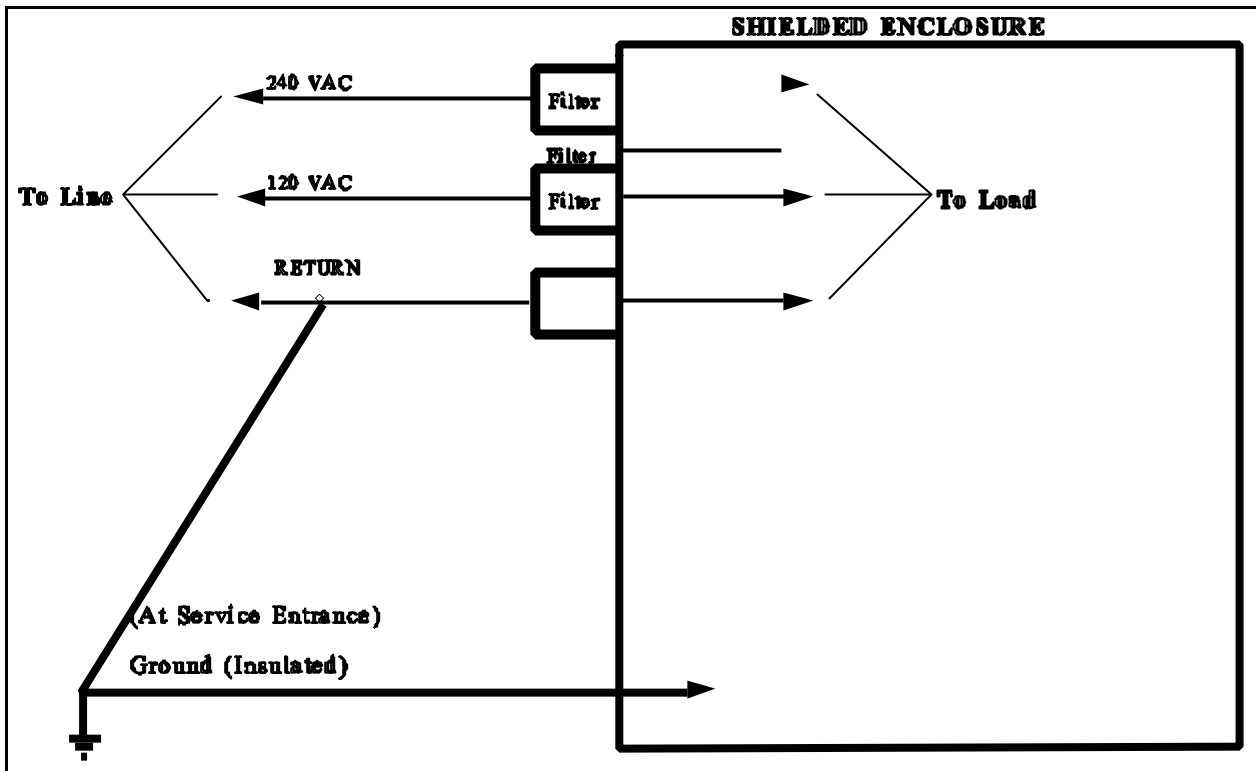

Figure 11 – Typical Power Line Configuration for 120/240 VAC, Single Phase

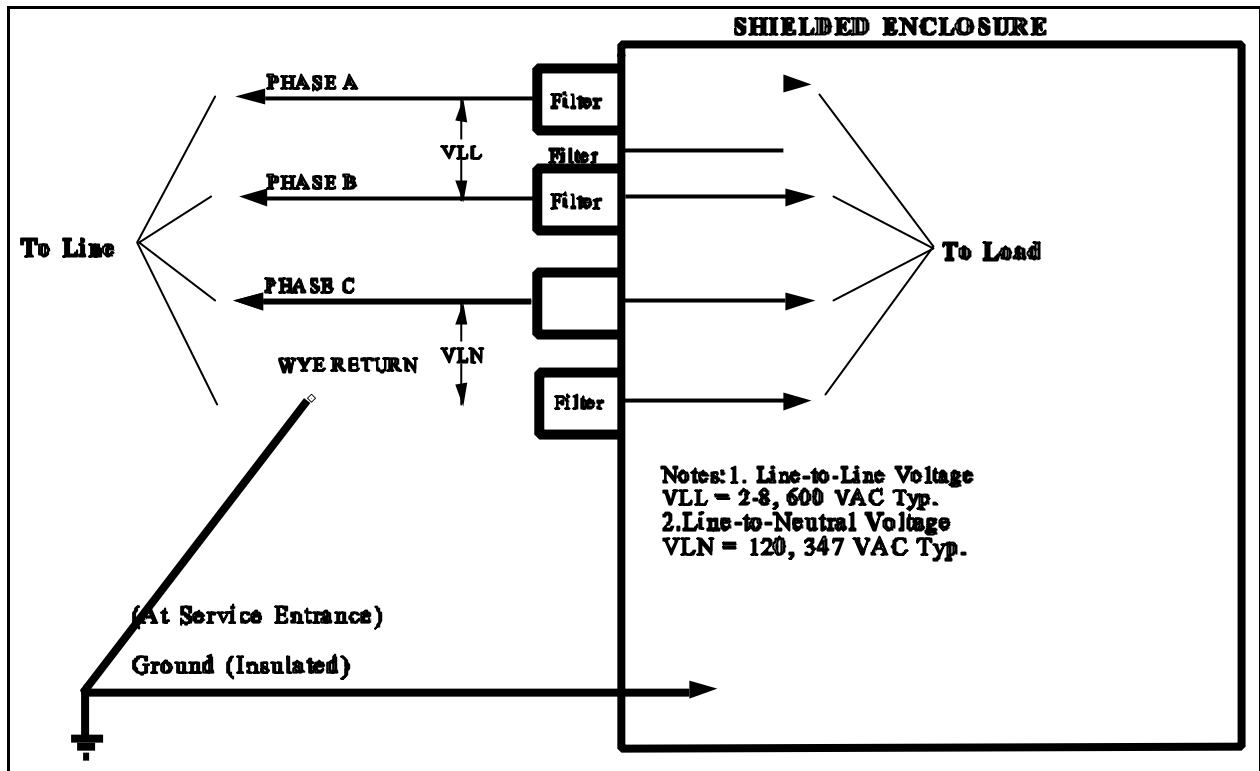

Figure 12 – Typical Power Line Configuration for 3 Phase, WYE

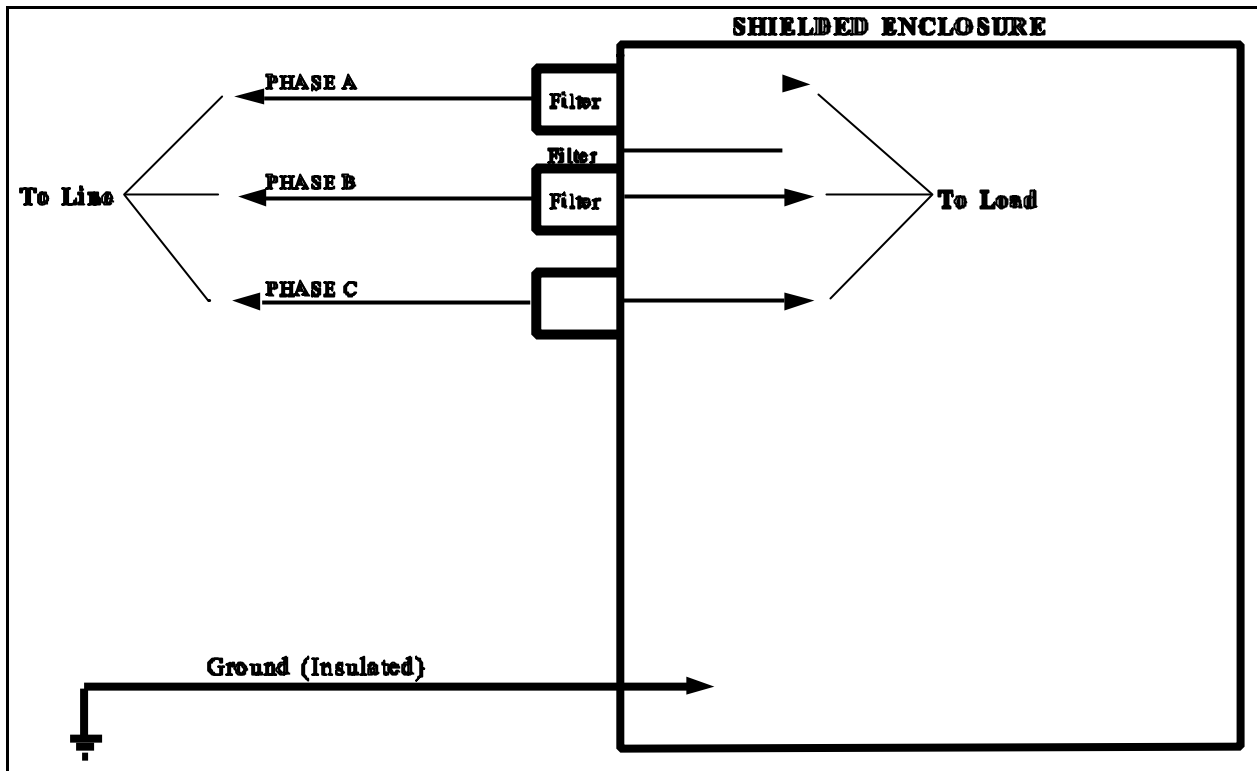

Figure 13 – Typical Power Line Configuration for 3 Phase, Delta

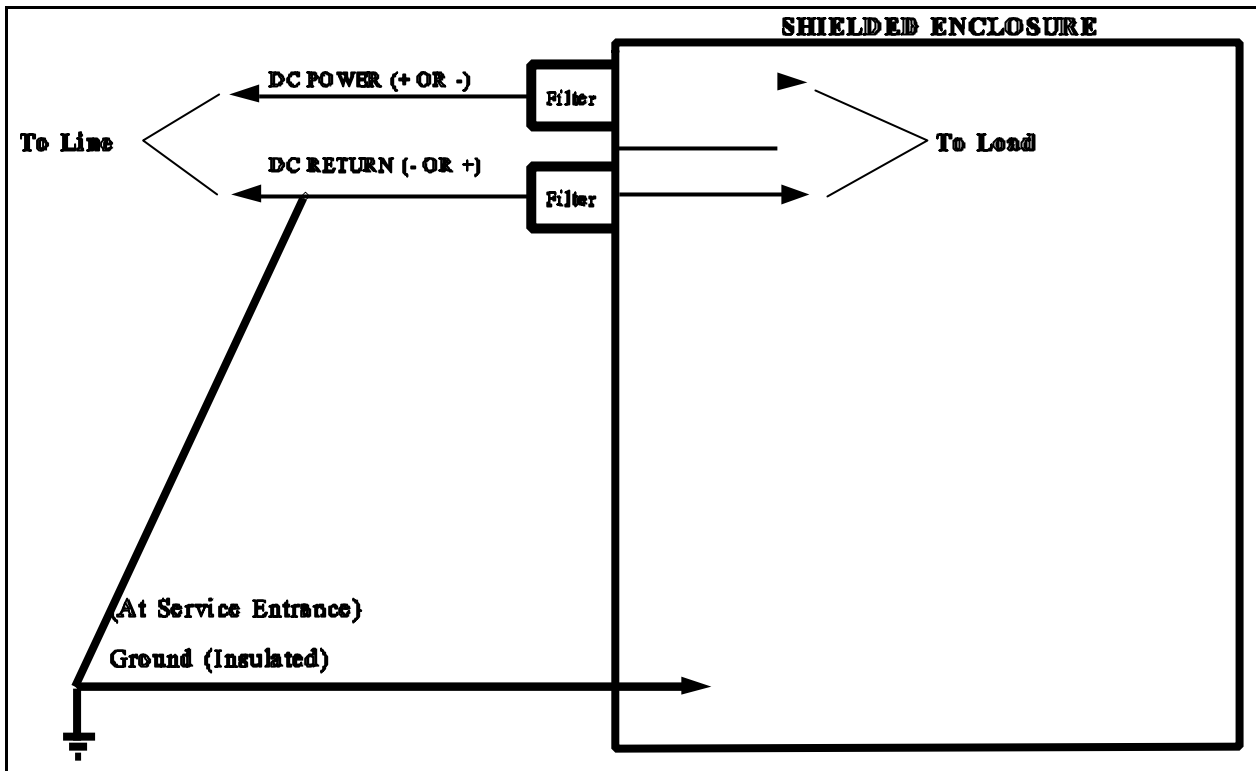

Figure 14 – Typical Power Line Configuration for DC Power