

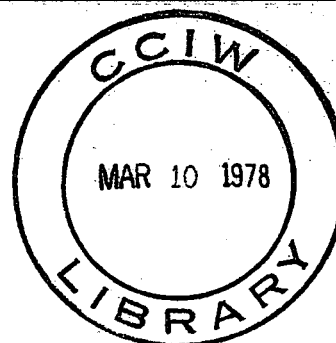

**Environment  
Canada**

**Environnement  
Canada**



**Canada  
Centre  
For Inland  
Waters**

**Centre  
Canadien  
Des Eaux  
Intérieures**

COASTAL ZONE LIMNOLOGICAL  
OBSERVATIONS IN LAKE ONTARIO  
AT BRONTE

June 1973 to March 1974

**UNPUBLISHED REPORT  
RAPPORT NON PUBLIE**

TD  
7  
J67  
1978

COASTAL ZONE LIMNOLOGICAL  
OBSERVATIONS IN LAKE ONTARIO  
AT BRONTE

June 1973 to March 1974

D. E. Jordan  
and  
J. A. Bull  
February 1978

## TABLE OF CONTENTS

	<u>Page Numbers</u>
Introduction	1
Experimental Program	2
Data Presentation (Discussion)	3
Appendix A: Data Summary	
Appendix B: Meteorological and Current Vector Summary	
Appendix C: Current Speed and Direction with Temperature Summary	
Appendix D: Progressive Vector Diagrams	
Appendix E: Current Component Summary	
Appendix F: Instrumentation Specification and Mooring Configurations	

### Acknowledgements

The authors' contribution has been to organize a routine presentation of data collected by CCIW during 1973 and 1974. Other persons have been involved as follows:

#### Personnel Involved

#### Contribution

C. R. Murthy	Organization and Planning
F. M. Boyce	Organization and Planning
J. O. Blanton*	Organization and Planning
R. Chapil	Data Reduction
F. Chiocchio	Data Reduction
V. Hamilton	Typing

The Scientific Support Division at CCIW provided personnel for field services and for the drafting of the figures.

\*Presently at Skidaway Inst. of Oceanography  
Savannah, Georgia

## INTRODUCTION

A projected increase in the utilization of coastal areas as effluent receiving waters has resulted in scientific effort towards the understanding of the complex transport and dispersion mechanisms characteristic of these zones. Attempts at identifying and quantifying significant flow regimes and mixing processes require, at least initially, an extensive data base from long term observational programs at various coastal sites. From such information, semi-empirical relationships can be formed and deterministic or stochastic models developed. The process of generalization of site-specific results to an overview of coastal physical processes requires that a series of representative sites be studied and the results intercompared and evaluated. With this objective in mind, CCIW has undertaken a series of long-term observational programs at selected sites in the Great Lakes to provide a detailed data base on important coastal areas. At present, extensive data is available for Douglas Point in Lake Huron, Bronte and Oshawa in Lake Ontario, and near Byng Inlet in Georgian Bay. Based on a joint observational program with Ontario Hydro, the Douglas Point study has been reported (Bull, J. and Farooqui, R. et al, 1976) as the first of a series of climatological summaries for the coastal zones. This present report for Bronte is the second of a series.

These reports are designed:

- (1) To provide documentation of and visual display of the experimental data set for each of the coastal sites investigated; and,
- (2) To provide easily accessible reference material for decision-making purposes.

### Experimental Program

During the period June 1973 to March 1974, the Basin Investigation and Modelling Section (BIMS) at CCIW undertook an extensive field study at Bronte on the NNW corner of Lake Ontario (Figure 1). The program was designed to provide time-series current and temperature measurements in the nearshore zone over the entire time period. These data were to be supplemented by meteorological time-series available at the CCIW site and from A.E.S. Toronto.

The basic layout of the experiment is shown in Figure 2. The current meters were moored on a line approximately perpendicular to the local shoreline with the first mooring placed 1.8 km offshore for reasons of operational depth limitation. Horizontal spacing was of the order of 0.5 km for the summer period increasing to 1 km for the winter. Each mooring consisted of two current meters, one located at 10 metres depth and the second at approximately 2 metres off the bottom. During the summer period, all instruments were

Plessey Model M021 (Roberts' Rotor Type) while for the second period, the lower current meters were Geodyne Model 920 (Savonius Rotor Type). Instrument specifications and typical mooring configurations are given in Appendix F. Figure A1 in Appendix A gives a bar chart summary of the current meter data available for this study. In addition, a more complete tabular summary is also presented.

#### Data Presentation

The data available from this study is presented in a format similar in organization and content to the Douglas Point Report. The data summaries are organized by calendar month in plotted displays given in 4 appendices as follows:

- (1) Appendix B shows a monthly meteorological summary followed by the set of six hourly averaged current and wind vector plots for the corresponding month, plus a statistical summary for that month. This display set is then repeated month by month for the entire period.
- (2) Appendix C gives temperature and current speed with direction plots filtered so as to retain the frequency band 0.0 to 0.2 cph. and organized by month and mooring respectively.
- (3) Appendix D contains progressive vector diagrams (PVD's) displaying the shallow meter measurements opposite

to the PVD's from the deeper instruments on a monthly basis. In these displays, the mean scalar speeds are averaged over a one hour time interval, and geographical direction is orientated with shore-parallel, land to the right flows pointing at the right hand side of the page.

- (4) Appendix E displays the current vector data as alongshore and onshore components subdivided into displays showing the shallow and then the deeper instrument measurements. A digital filter has been applied to remove periods less than five hours from the component time series.

More detailed descriptions of the contents and data handling procedures for (1) and (2) above are given in Reference 1. Displays (3) and (4) are unique to this report and reflect summaries that we have found useful in preliminary digestion of the data. Both are standard techniques for summarizing time-series data of this type.



#### REFERENCES

BULL, J. and Farooqui, R. et al, 1976. Coastal Zone Limnological Observations in Lake Huron at Bruce Nuclear Power Development May - November, 1974. Joint CCIW - Ontario Hydro Report, CCIW Paper No. 17, 1976.

# CCIW lake current observations (Lake Ontario 1973/74)

• Location and designation of current meter stations

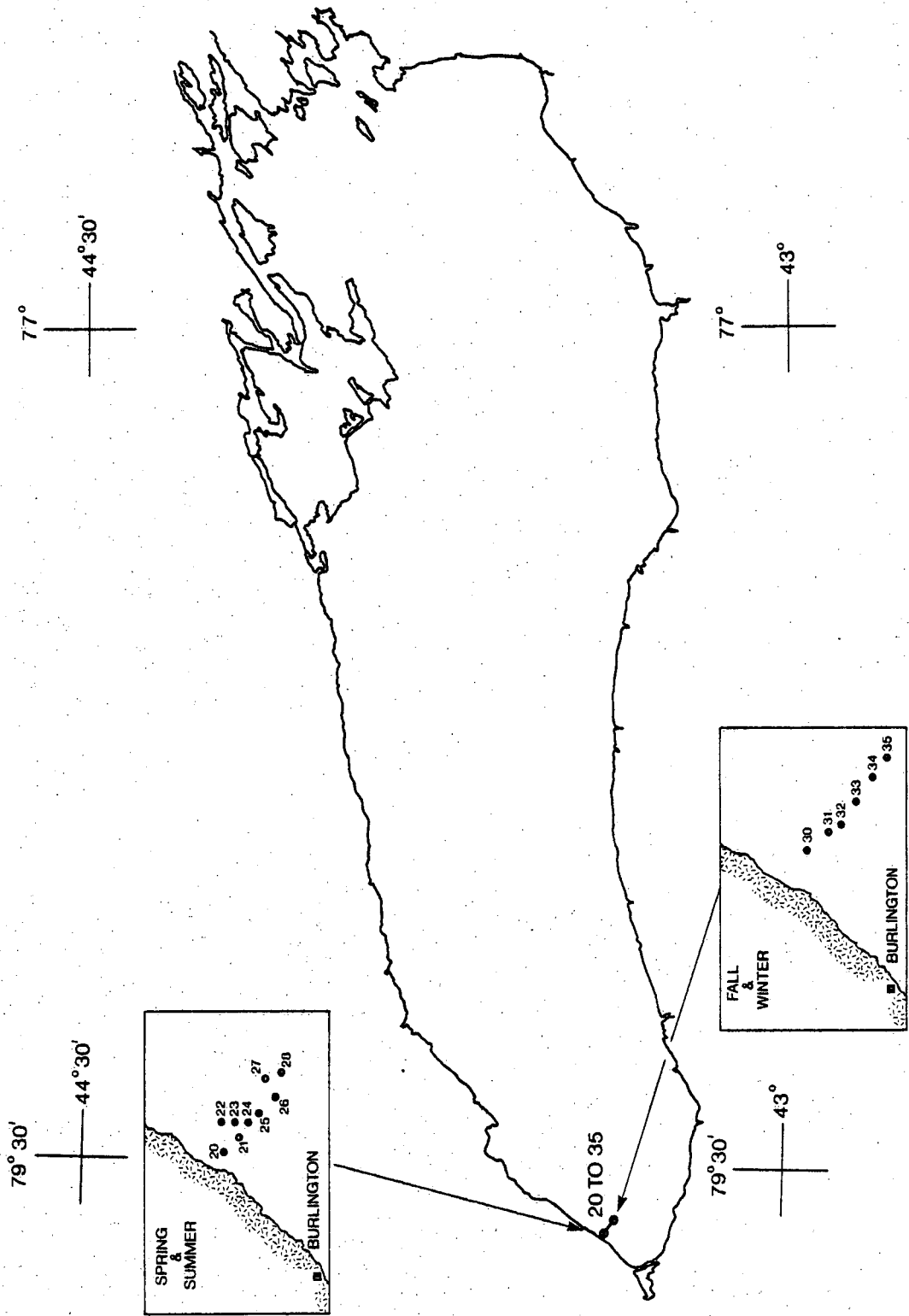

Figure 1.

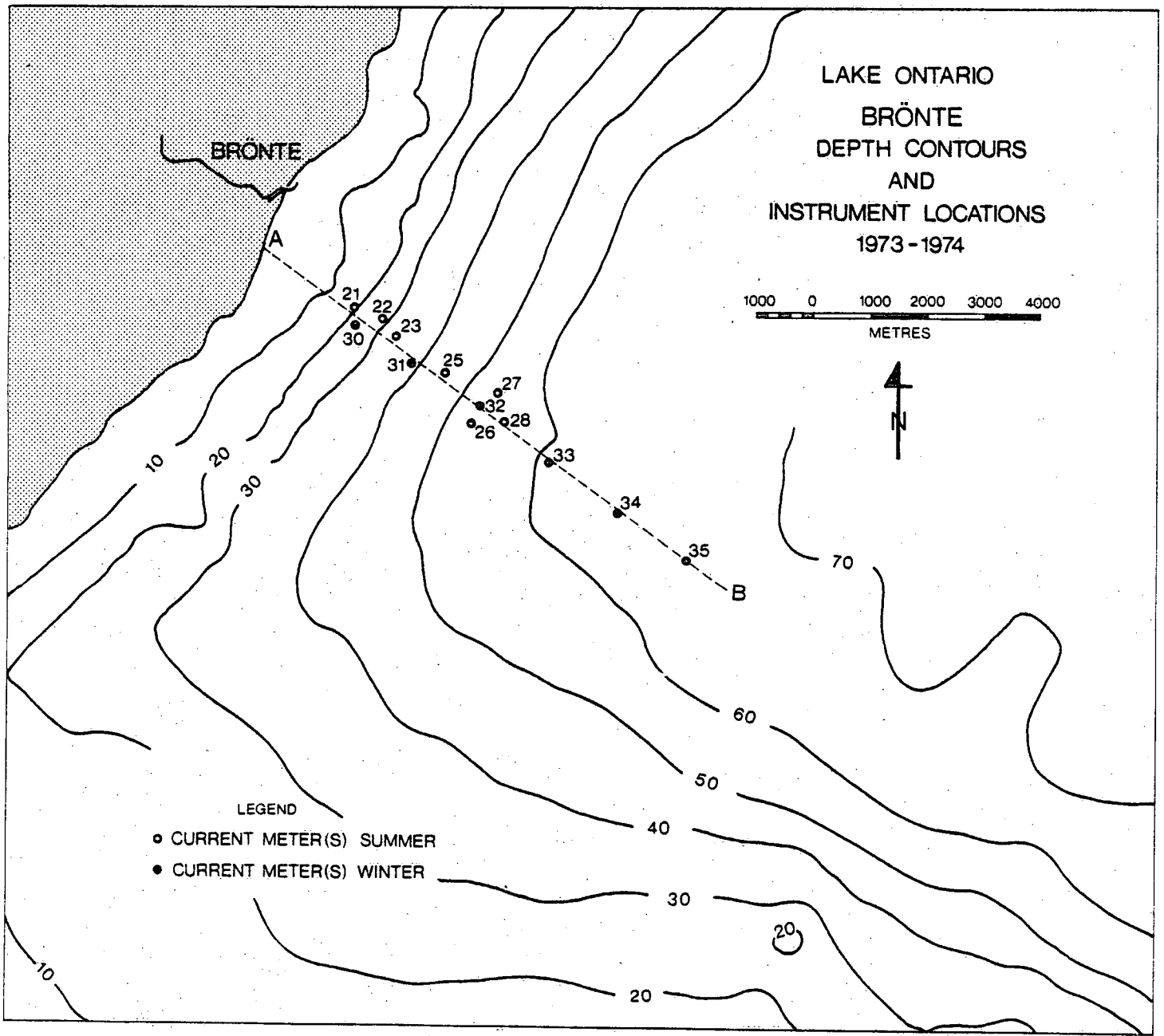
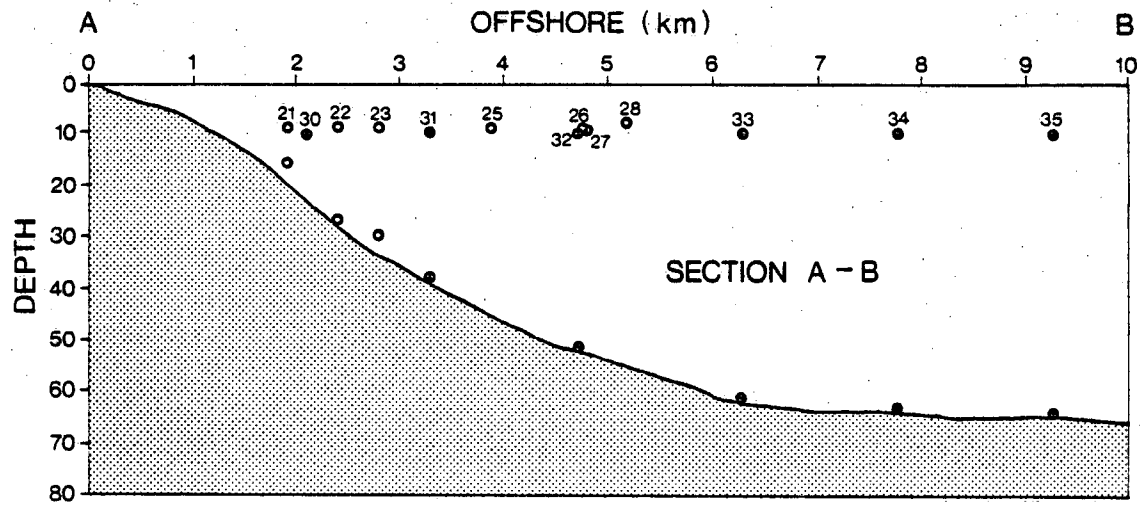

Figure 2.

APPENDIX A: DATA SUMMARIES

TIME SERIES DATA COLLECTION SUMMARY: BRONTE, LAKE ONTARIO, 1973-74

Mooring Number	Variables Measured	Instruments	Water Depth m	Instrument Depths m
21	CS/CD/WT	PCM	20	9 16
22	CS/CD/WT	PCM PCM	31	9 27
23	CS/CD/WT	PCM PCM	34	9 30
25	CS/CD/WT	PCM	48	9
26	CS/CD/WT	PCM	50	9
27	CS/CD/WT	PCM	55	9
28	CS/CD/WT	PCM	59	8
30	CS/CD/WT	PCM	21	10
31	CS/CD/WT	PCM GCM	41	10 38
32	CS/CD/WT	PCM PCM/GCM	54	10 51
33	CS/CD/WT	PCM PCM/GCM	64	10 61
34	CS/CD/WT	PCM/GCM PCM/GCM	66	10 63
35	CS/CD/WT	PCM PCM	67	10 64

CS Current Speed  
 CD Current Direction  
 WT Water Temperature  
 PCM Plessey Current Meter  
 GCM Geodyne Current Meter

Useful Data Period	Sampling Rate min	Latitude	Longitude
June 25/Jul 08	20	43° 22' 29" N	79° 41' 38" W
June 25/Oct 02	20		
June 25/Oct 18	20	43° 22' 22" N	79° 41' 17" W
June 25/Sep 05	20		
June 25/Oct 18	20	43° 22' 12" N	79° 41' 06" W
June 25/Jul 21	20		
June 26/Sep 22	20	43° 21' 51" N	79° 40' 28" W
June 26/Oct 18	20	43° 21' 23" N	79° 40' 06" W
June 26/Oct 18	20	43° 21' 34" N	79° 39' 48" W
June 26/Oct 18	20	43° 21' 24" N	79° 39' 40" W
Oct 18/Mar 18	20/30	43° 22' 18" N	79° 41' 51" W
Oct 18/Mar 18	20/30	43° 21' 56" N	79° 40' 54" W
Dec 04/Mar 18	20		
Oct 18/Dec 04	20	43° 21' 33" N	79° 40' 00" W
Oct 18/Mar 24	20		
Oct 18/Mar 24	20/30	43° 21' 00" N	79° 39' 06" W
Oct 18/Mar 24	20		
Oct 18/Mar 10	20	43° 20' 32" N	79° 38' 12" W
Oct 18/Mar 24	20		
Oct 18/Dec 10	20	43° 20' 06" N	79° 37' 18" W
Oct 18/Dec 10	20		

# CCIW lake current observations (Lake Ontario 1973/74)

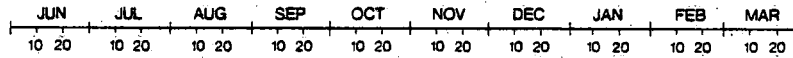

## Resume of temperature and current velocity data return

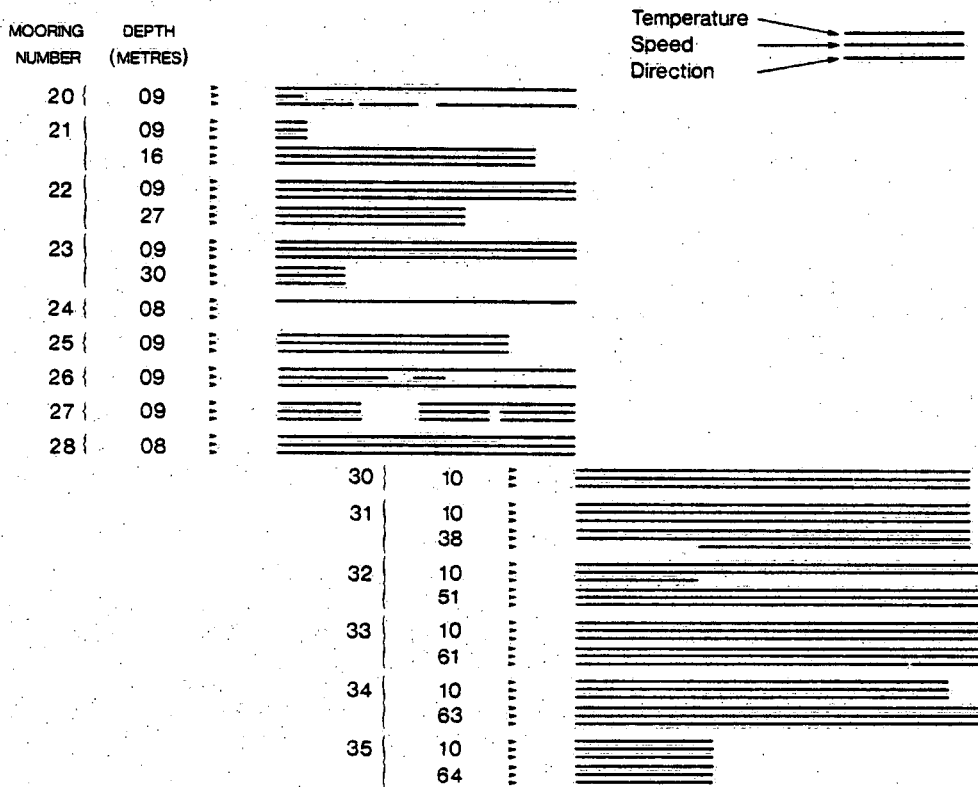

Figure A1.

APPENDIX B: METEOROLOGICAL AND CURRENT VECTOR SUMMARY



# METEOROLOGICAL DATA

MOORING: BURLINGTON DATE: JUNE 1973

## FILTERED WIND (0.0 TO 0.05 CPH)

0 10 M/SEC

N  
↑



## FILTERED WIND (0.0 TO 0.2 CPH) \*

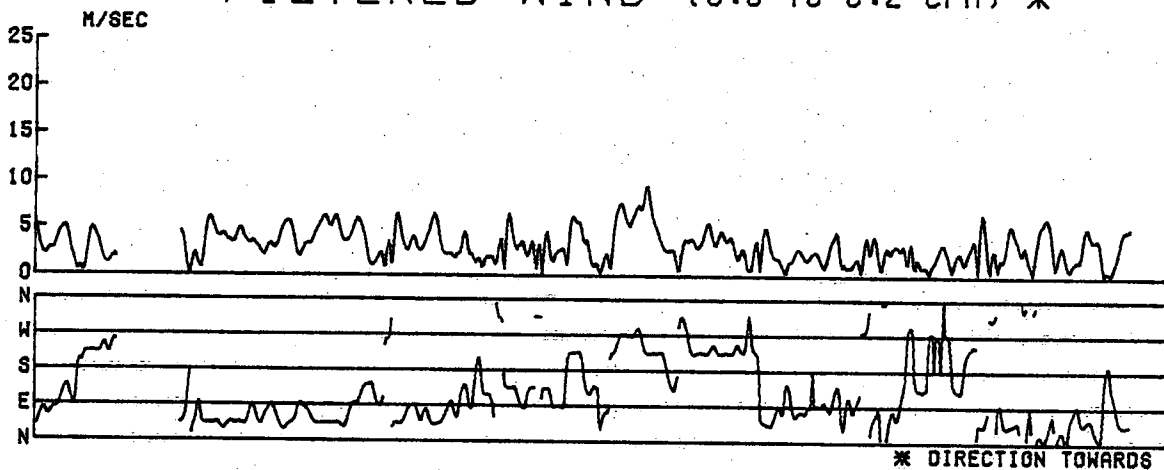

## TEMPERATURE °C

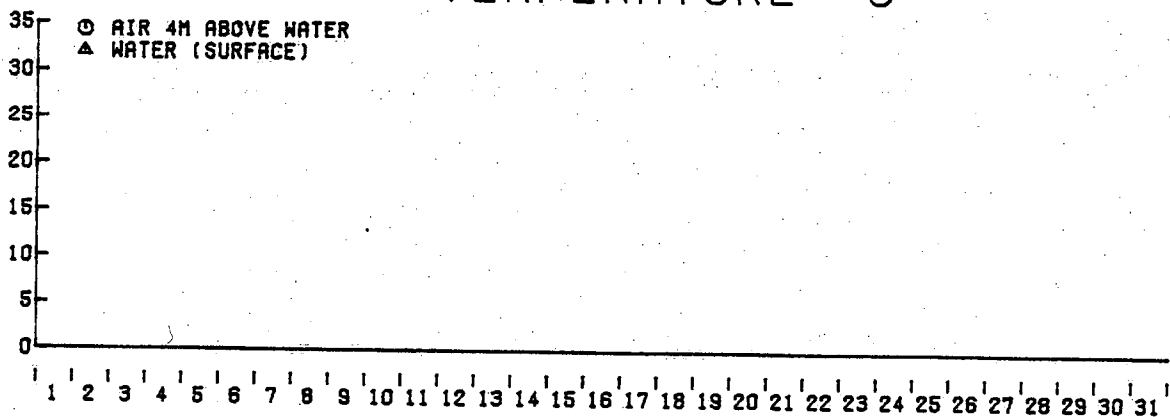

### DAILY MAXIMUM AND MINIMUM AIR TEMPERATURE

DAY	TMAX	TMIN	DAY	TMAX	TMIN	DAY	TMAX	TMIN	DAY	TMAX	TMIN
1			9			17			25		
2			10			18			26		
3			11			19			27		
4			12			20			28		
5			13			21			29		
6			14			22			30		
7			15			23			31		
8			16			24					

Insufficient Data

For Rose Plot

MOORING : 21

DATE : JUNE 1973

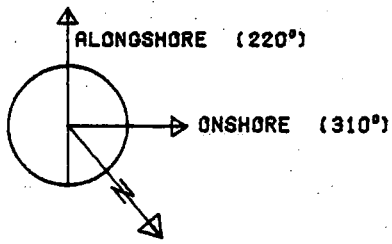

WINDSPEED<sup>2</sup>

0 40 M<sup>2</sup>/SEC<sup>2</sup>

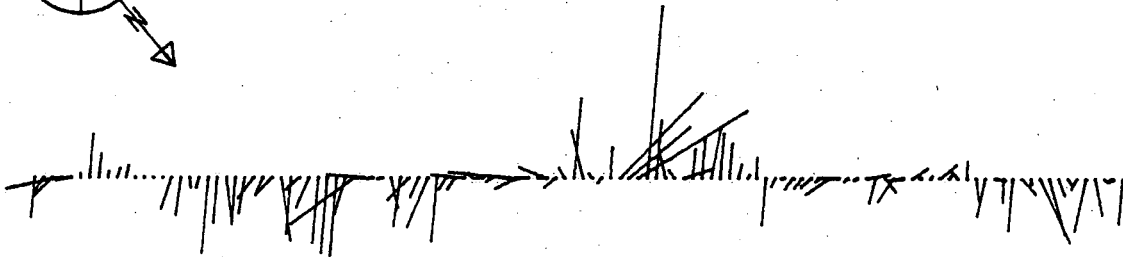

FILTERED CURRENT  
(0.0 TO 0.05 CPH)

DEPTH: 9 M

0 10 CM/SEC



DEPTH: 16 M



1' 2' 3' 4' 5' 6' 7' 8' 9' 10' 11' 12' 13' 14' 15' 16' 17' 18' 19' 20' 21' 22' 23' 24' 25' 26' 27' 28' 29' 30' 31'

Insufficient Data

For Rose Plot

MOORING : 22

DATE : JUNE 1973

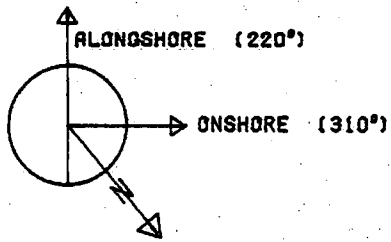

WINDSPEED<sup>2</sup>

0 40 M<sup>2</sup>/SEC<sup>2</sup>

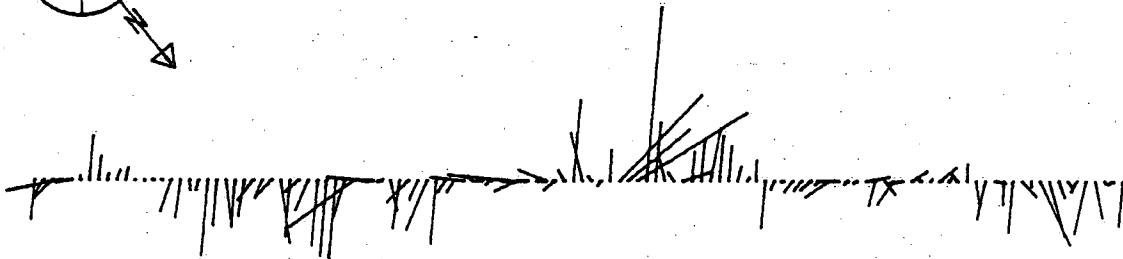

FILTERED CURRENT  
(0.0 TO 0.05 CPH)

DEPTH: 9 M

0 10 CM/SEC



DEPTH: 27 M



1 2 3 4 5 6 7 8 9 10 11 12 13 14 15 16 17 18 19 20 21 22 23 24 25 26 27 28 29 30 31

Insufficient Data

For Rose Plot

MOORING : 23

DATE : JUNE 1973

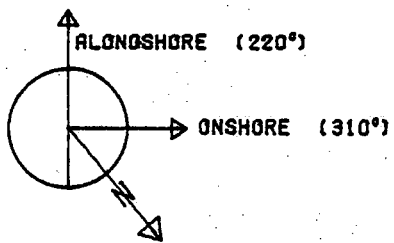

WINDSPEED<sup>2</sup>

0 40 M<sup>2</sup>/SEC<sup>2</sup>

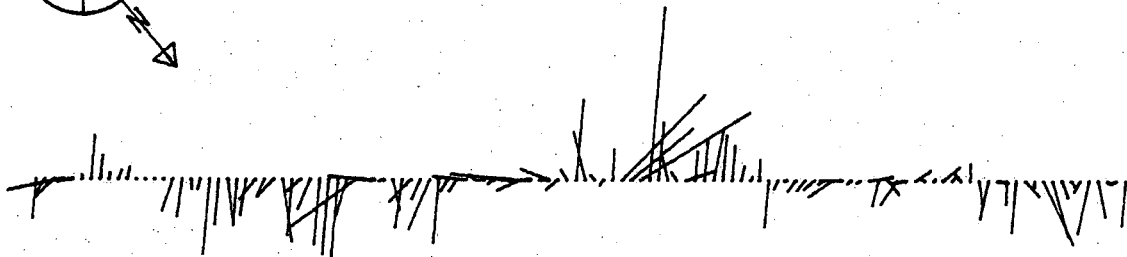

DEPTH: 9 M

FILTERED CURRENT  
(0.0 TO 0.05 CPH)

0 10 CM/SEC



DEPTH: 30 M



1 2 3 4 5 6 7 8 9 10 11 12 13 14 15 16 17 18 19 20 21 22 23 24 25 26 27 28 29 30 31

Insufficient Data  
For Rose Plot



MOORING : 25

DATE : JUNE 1973

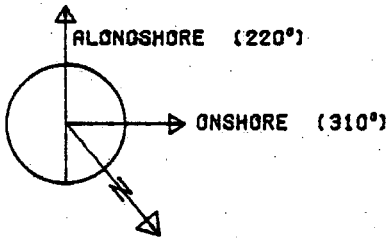

WINDSPEED<sup>2</sup>

0 40 M<sup>2</sup>/SEC<sup>2</sup>

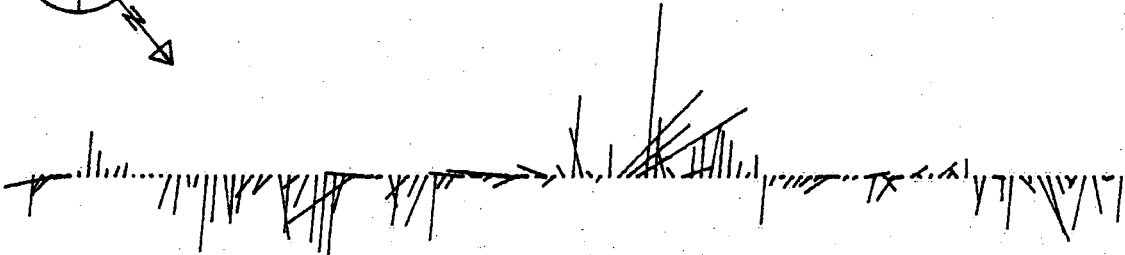

FILTERED CURRENT  
(0.0 TO 0.05 CPH)

DEPTH: 9 M

0 10 CM/SEC



DEPTH: M

1 2 3 4 5 6 7 8 9 10 11 12 13 14 15 16 17 18 19 20 21 22 23 24 25 26 27 28 29 30 31

Insufficient Data

For Rose Plot

MOORING : 26

DATE : JUNE 1973

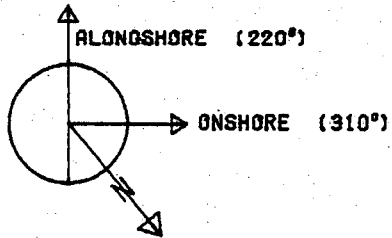

WINDSPEED<sup>2</sup>

0 — 40 M<sup>2</sup>/SEC<sup>2</sup>

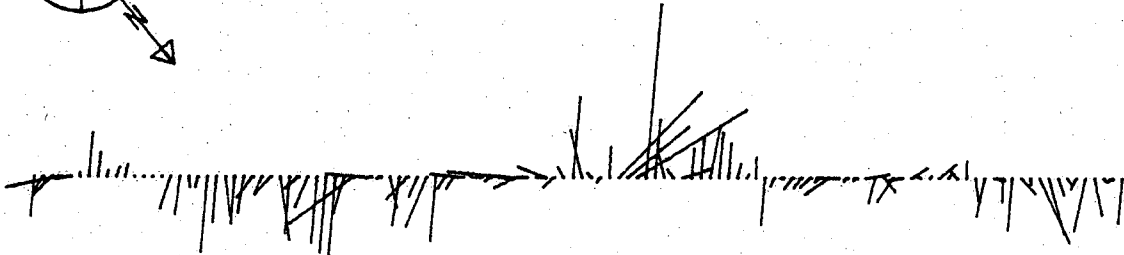

DEPTH: 9 M

FILTERED CURRENT  
(0.0 TO 0.05 CPH)

0 — 10 CM/SEC



DEPTH: M

1' 2' 3' 4' 5' 6' 7' 8' 9' 10' 11' 12' 13' 14' 15' 16' 17' 18' 19' 20' 21' 22' 23' 24' 25' 26' 27' 28' 29' 30' 31'

Insufficient Data  
For Rose Plot

MOORING : 27

DATE : JUNE 1973

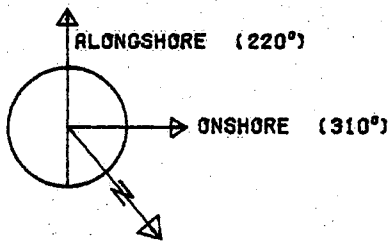

WINDSPEED<sup>2</sup>

0 40 M<sup>2</sup>/SEC<sup>2</sup>

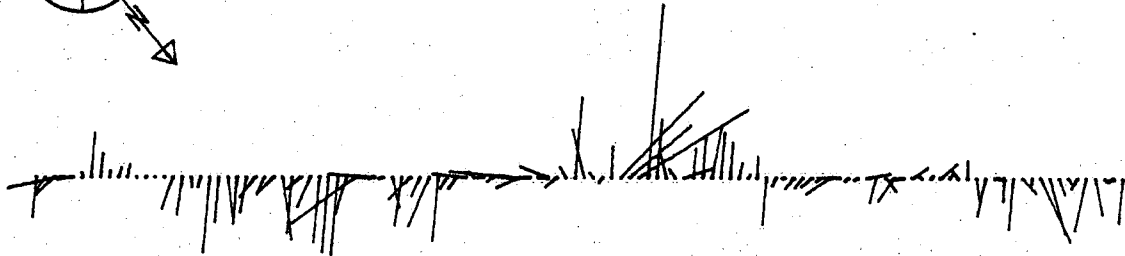

FILTERED CURRENT  
(0.0 TO 0.05 CPH)

DEPTH: 9 M

0 10 CM/SEC



DEPTH: M

1 2 3 4 5 6 7 8 9 10 11 12 13 14 15 16 17 18 19 20 21 22 23 24 25 26 27 28 29 30 31

Insufficient Data

For Rose Plot

MOORING : 28

DATE : JUNE 1973

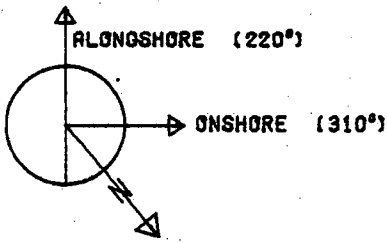

WINDSPEED<sup>2</sup>

0 40 M<sup>2</sup>/SEC<sup>2</sup>



FILTERED CURRENT  
(0.0 TO 0.05 CPH)

DEPTH: 8 M

0 10 CM/SEC



DEPTH: M

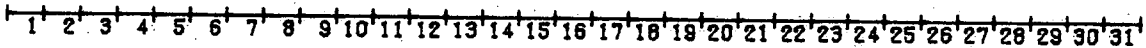

# METEOROLOGICAL DATA

MOORING: BURLINGTON DATE: JULY 1973

## FILTERED WIND (0.0 TO 0.05 CPH)

0 10 M/SEC

N ↑

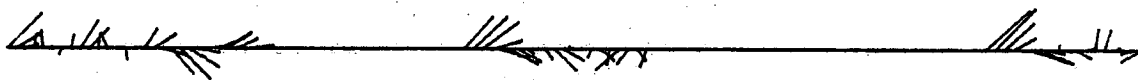

## FILTERED WIND (0.0 TO 0.2 CPH) \*

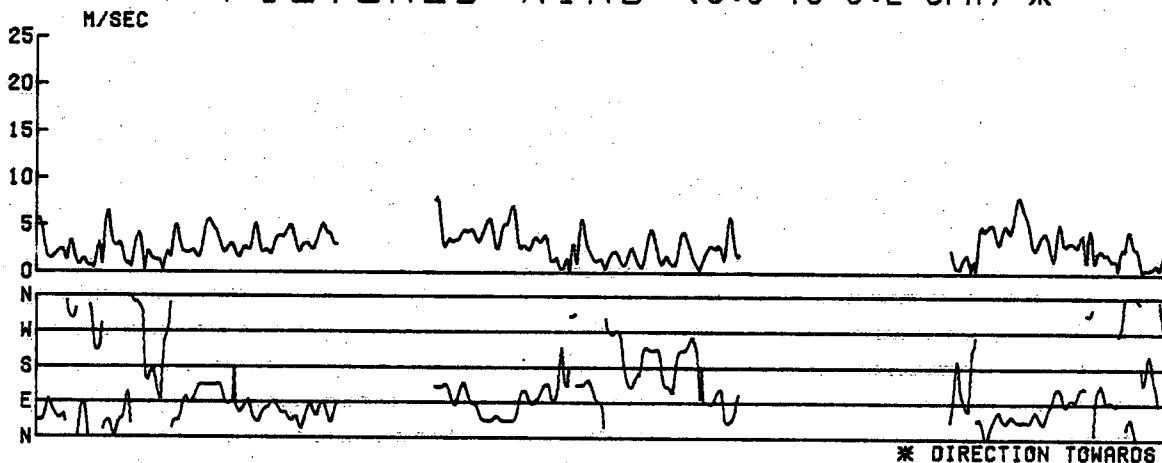

\* DIRECTION TOWARDS

## TEMPERATURE °C

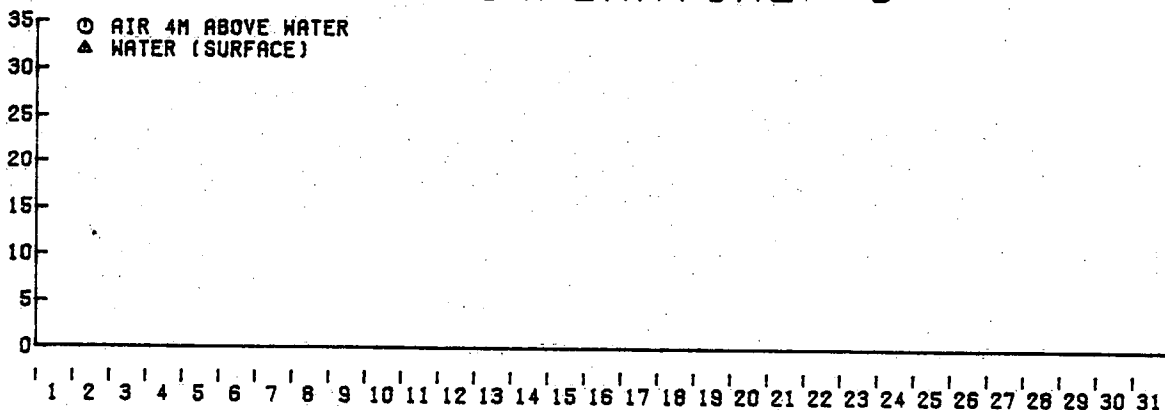

### DAILY MAXIMUM AND MINIMUM AIR TEMPERATURE

DAY	TMAX	TMIN	DAY	TMAX	TMIN	DAY	TMAX	TMIN	DAY	TMAX	TMIN
1			9			17			25		
2			10			18			26		
3			11			19			27		
4			12			20			28		
5			13			21			29		
6			14			22			30		
7			15			23			31		
8			16			24					



MOORING: 21      DATE: JULY 1973  
 MONTHLY SUMMARY: WIND AND CURRENT\*

WIND  
 — 0-3 M/SEC  
 = 3-7 M/SEC  
 = 7 M/SEC

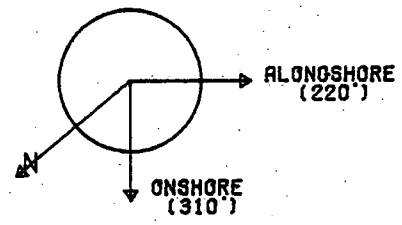
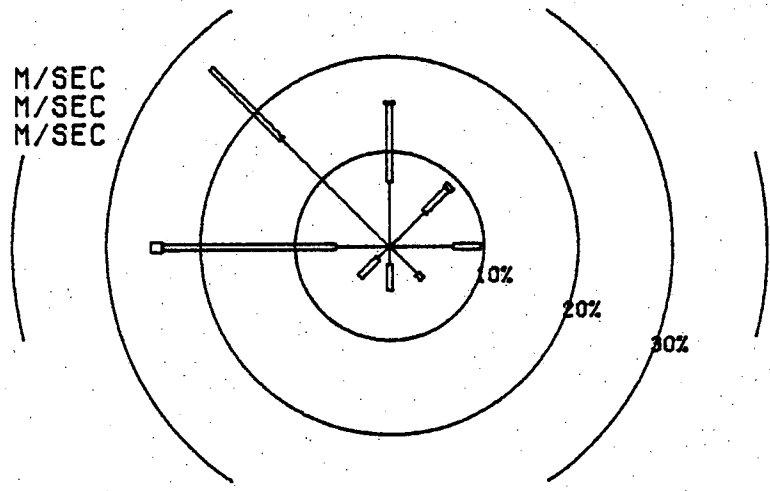

CURRENT  
 — 0-5 CM/SEC  
 = 5-15 CM/SEC  
 = 15 CM/SEC

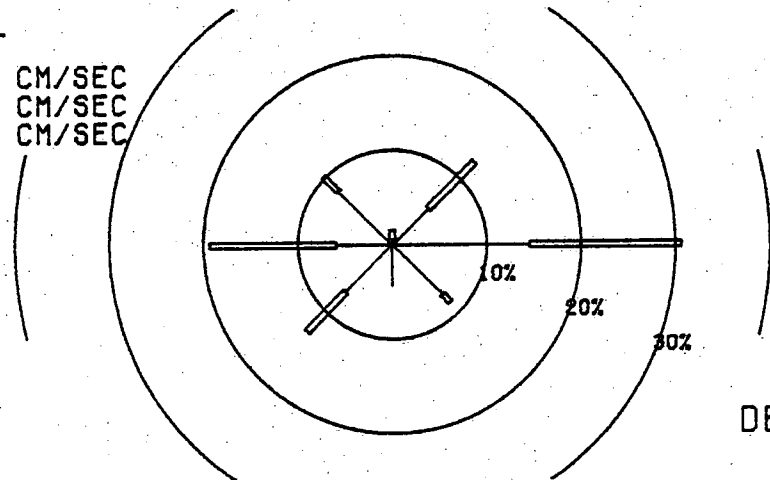

DEPTH: 9 M

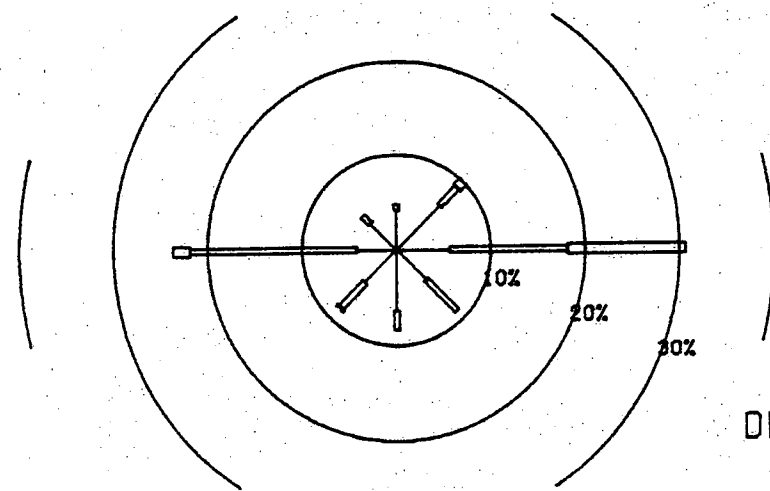

DEPTH: 16 M

\* DIRECTION TOWARDS

MOORING : 21

DATE : JULY 1973

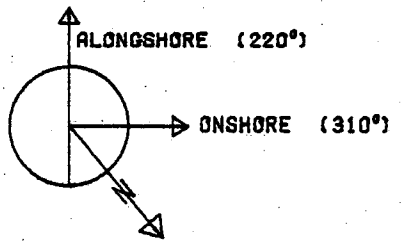

WINDSPEED<sup>2</sup>

0 40 M<sup>2</sup>/SEC<sup>2</sup>

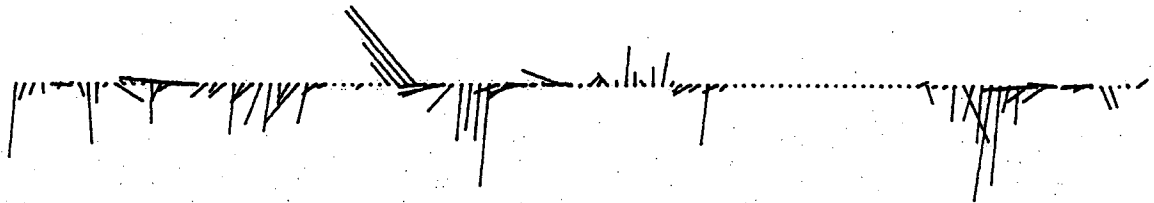

FILTERED CURRENT  
(0.0 TO 0.05 CPH)

DEPTH: 9 M

0 10 CM/SEC

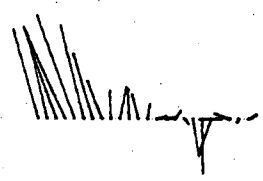

DEPTH: 16 M



1 2 3 4 5 6 7 8 9 10 11 12 13 14 15 16 17 18 19 20 21 22 23 24 25 26 27 28 29 30 31

MOORING: 22      DATE: JULY 1973  
 MONTHLY SUMMARY: WIND AND CURRENT\*

WIND  
 — 0-3 M/SEC  
 = 3-7 M/SEC  
 ≡ ≥ 7 M/SEC

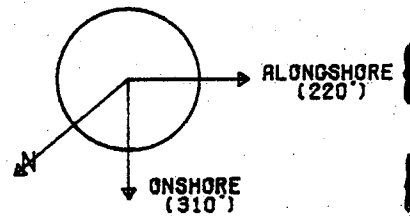
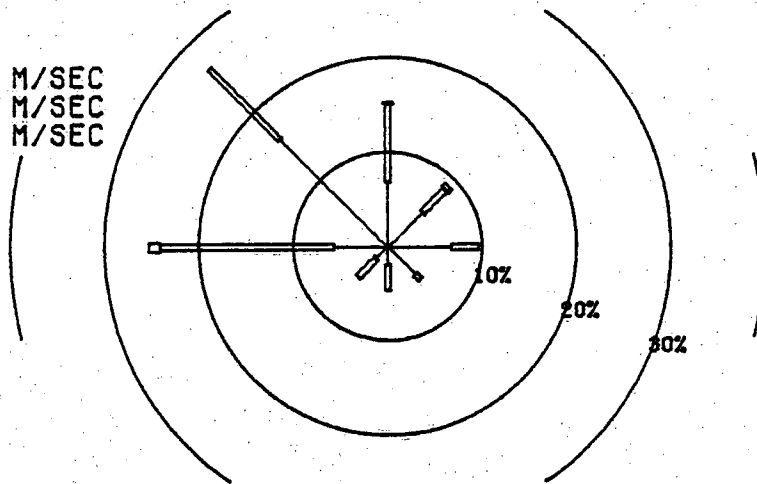

CURRENT  
 — 0-5 CM/SEC  
 = 5-15 CM/SEC  
 ≡ ≥ 15 CM/SEC

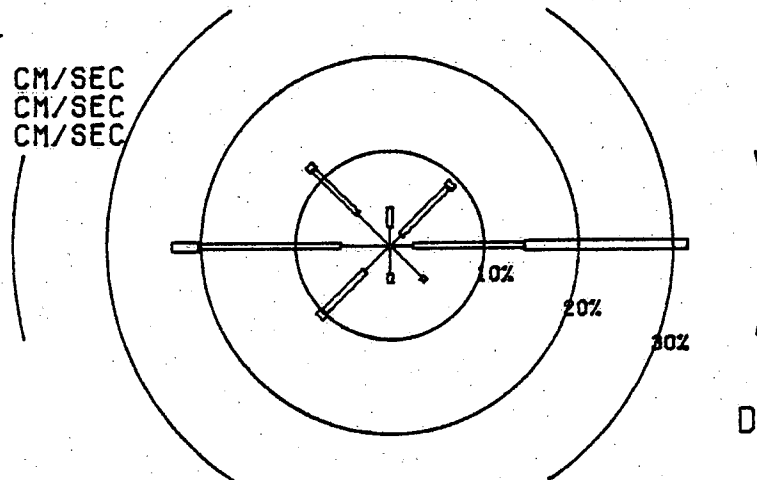

DEPTH: 9 M

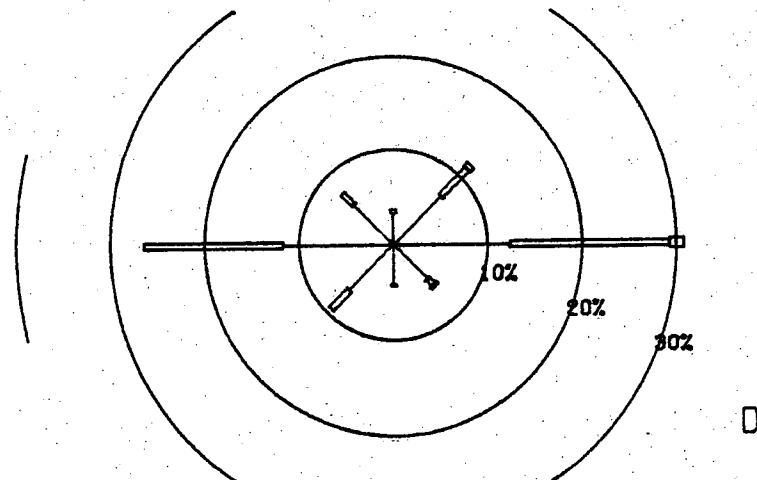

DEPTH: 27 M

\* DIRECTION TOWARDS

MOORING : 22

DATE : JULY 1973

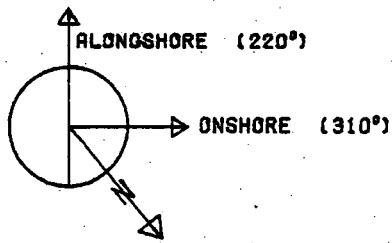

WINDSPEED<sup>2</sup>

0 40 M<sup>2</sup>/SEC<sup>2</sup>

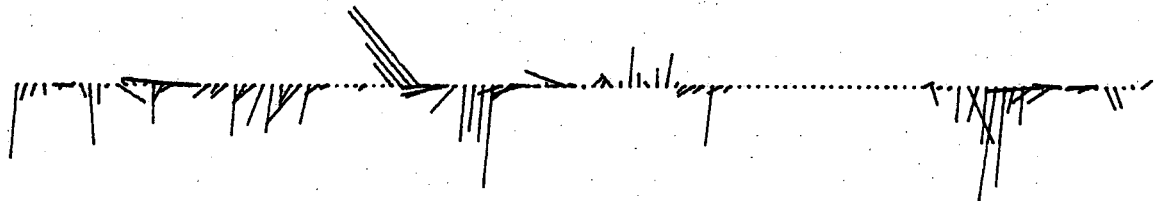

FILTERED CURRENT  
(0.0 TO 0.05 CPH)

DEPTH: 9 M

0 10 CM/SEC

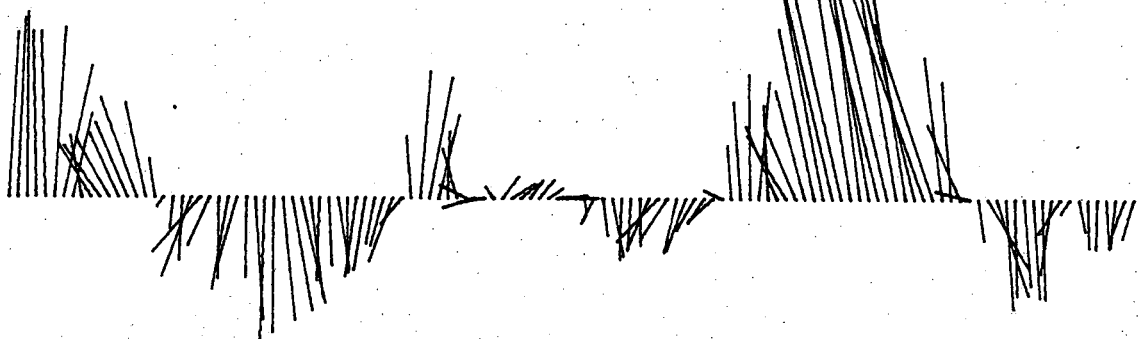

DEPTH: 27 M

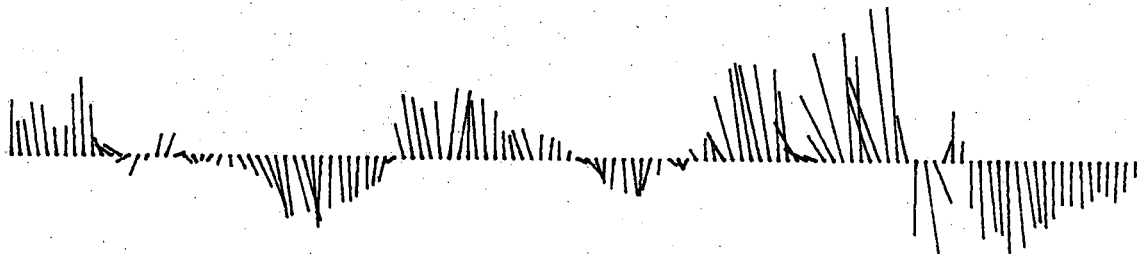

1 2 3 4 5 6 7 8 9 10 11 12 13 14 15 16 17 18 19 20 21 22 23 24 25 26 27 28 29 30 31

MOORING: 23      DATE: JULY 1973  
 MONTHLY SUMMARY: WIND AND CURRENT\*

WIND  
 — 0-3 M/SEC  
 = 3-7 M/SEC  
 ≡ ≥ 7 M/SEC

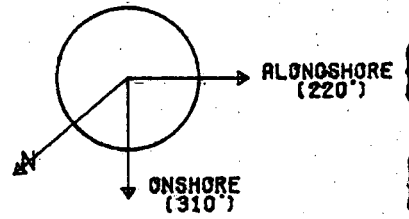
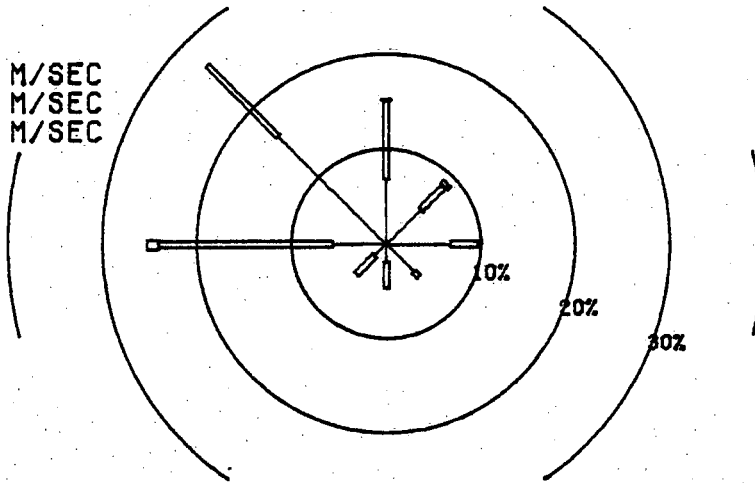

CURRENT  
 — 0-5 CM/SEC  
 = 5-15 CM/SEC  
 ≡ ≥ 15 CM/SEC

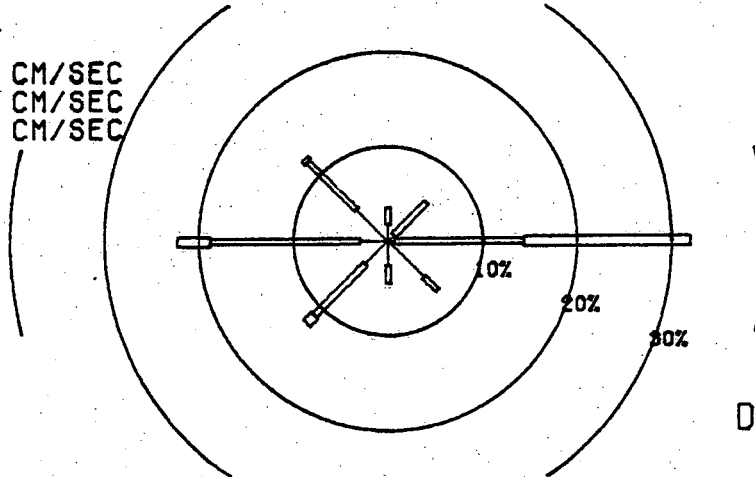

DEPTH: 9 M

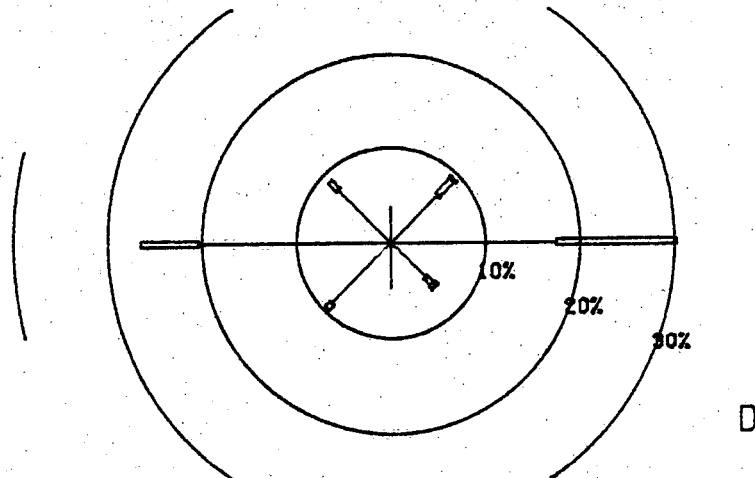

DEPTH: 30 M

\* DIRECTION TOWARDS

MOORING : 23

DATE : JULY 1973

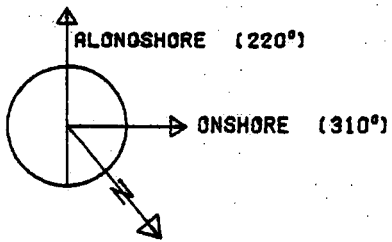

WINDSPEED<sup>2</sup>

0 40 M<sup>2</sup>/SEC<sup>2</sup>

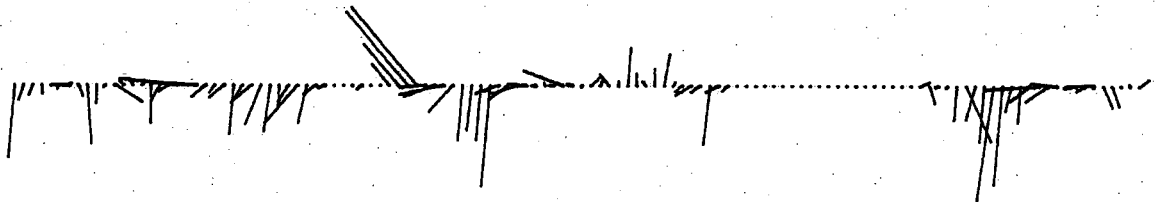

DEPTH: 9 M

FILTERED CURRENT  
(0.0 TO 0.05 CPH)

0 10 CM/SEC

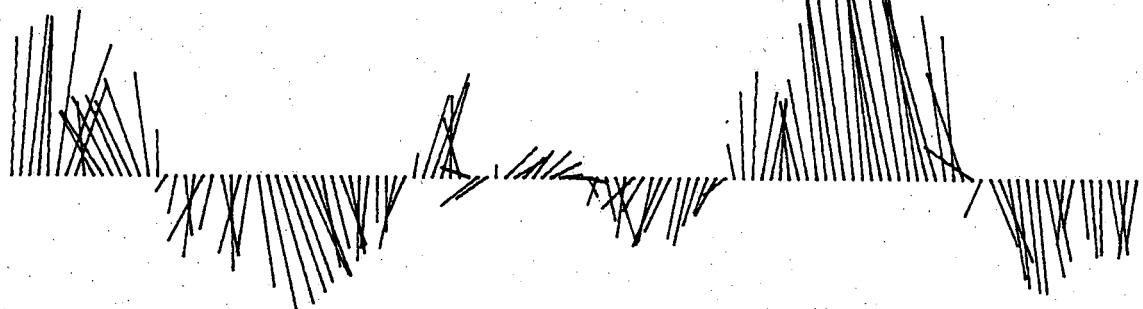

DEPTH: 30 M

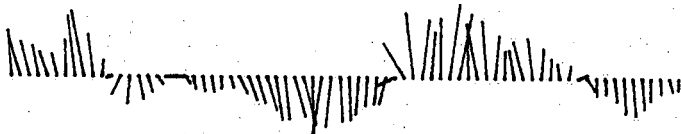

1 2 3 4 5 6 7 8 9 10 11 12 13 14 15 16 17 18 19 20 21 22 23 24 25 26 27 28 29 30 31

MOORING: 25      DATE: JULY 1973  
 MONTHLY SUMMARY: WIND AND CURRENT\*

WIND  
 — 0-3 M/SEC  
 = 3-7 M/SEC  
 ≡ ≥ 7 M/SEC

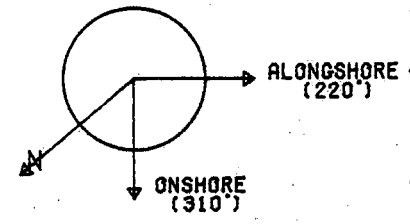
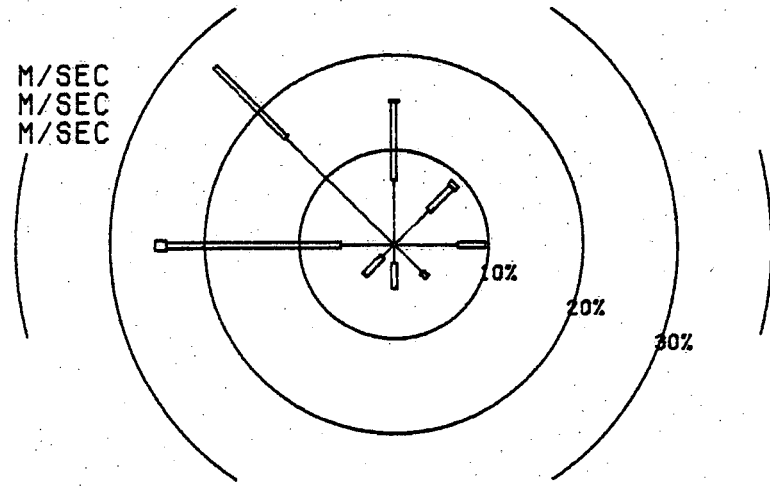

CURRENT  
 — 0-5 CM/SEC  
 = 5-15 CM/SEC  
 ≡ ≥ 15 CM/SEC

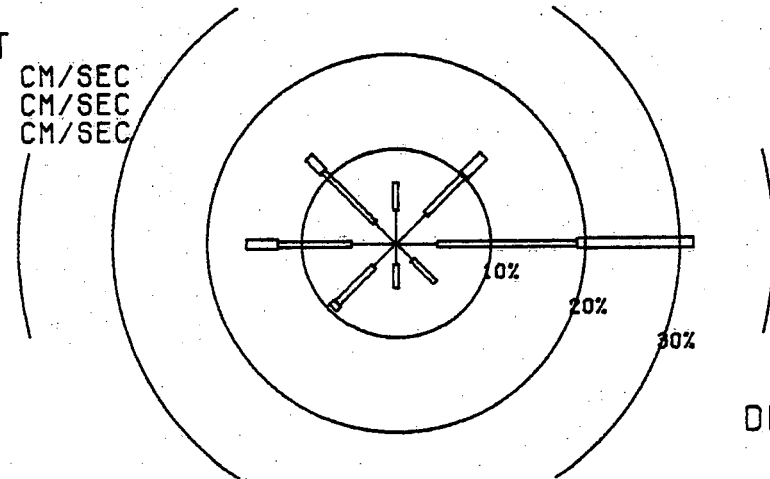

DEPTH: 9 M

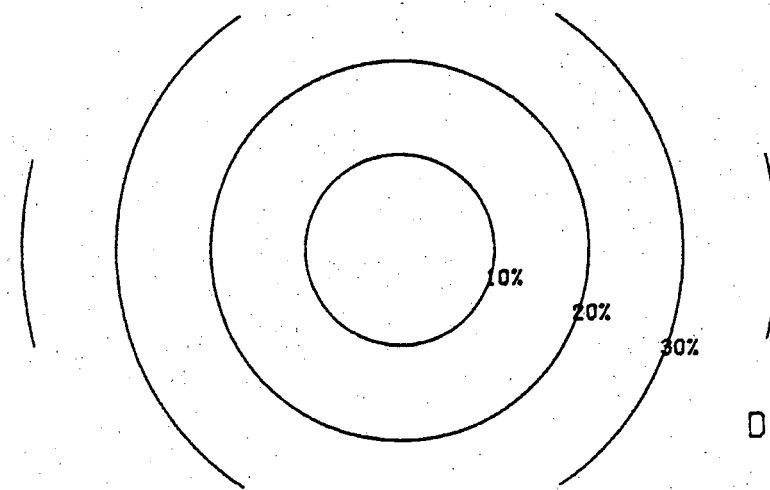

DEPTH: M

\* DIRECTION TOWARDS

MOORING : 25

DATE : JULY 1973

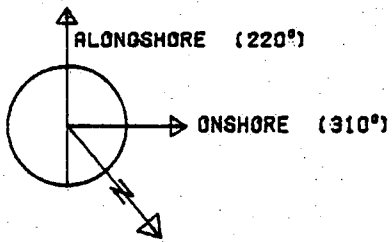

WINDSPEED<sup>2</sup>

0 40 M<sup>2</sup>/SEC<sup>2</sup>

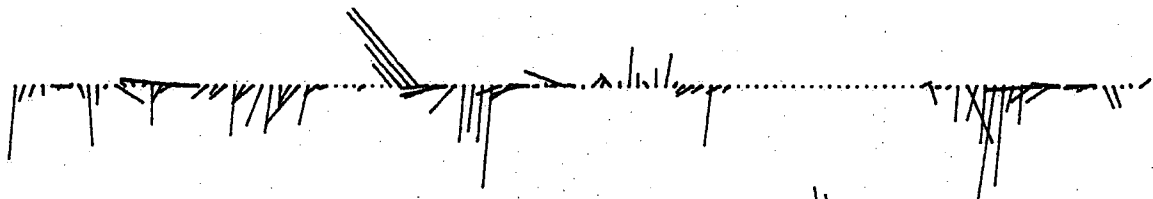

FILTERED CURRENT  
(0.0 TO 0.05 CPH)

DEPTH: 9 M

0 10 CM/SEC

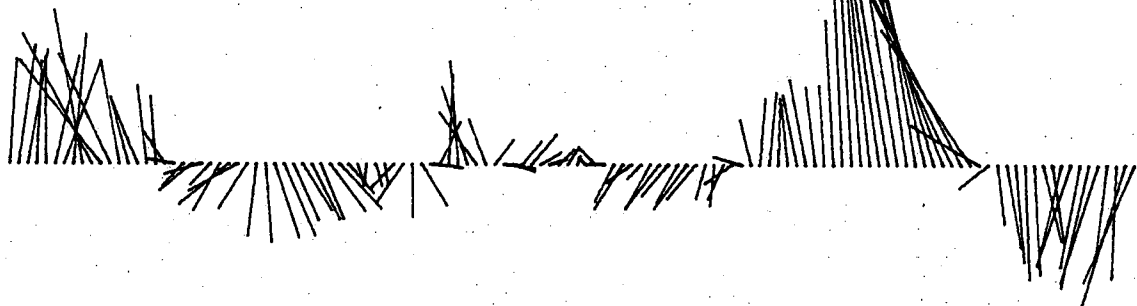

DEPTH: M

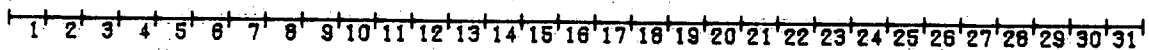



MOORING: 26      DATE: JULY 1973  
 MONTHLY SUMMARY: WIND AND CURRENT\*

WIND  
 — 0-3 M/SEC  
 = 3-7 M/SEC  
 ≡ ≥ 7 M/SEC

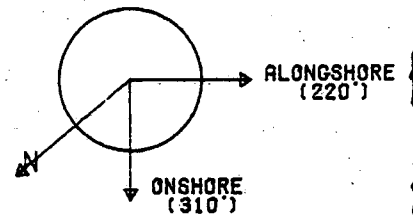
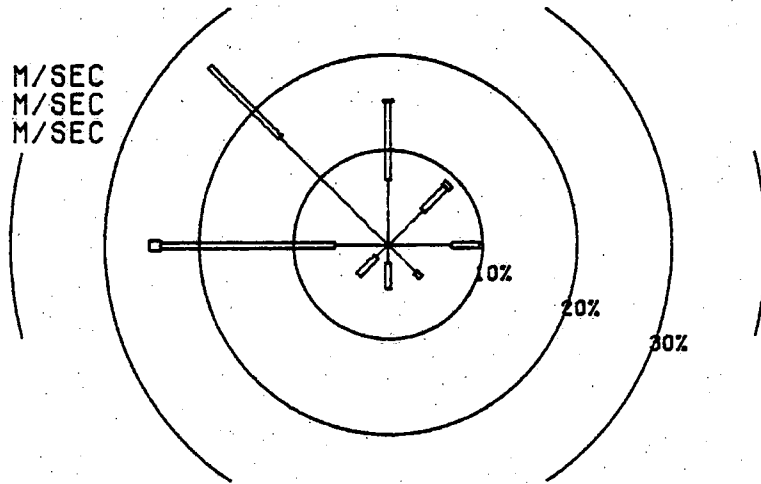

CURRENT  
 — 0-5 CM/SEC  
 = 5-15 CM/SEC  
 ≡ ≥ 15 CM/SEC

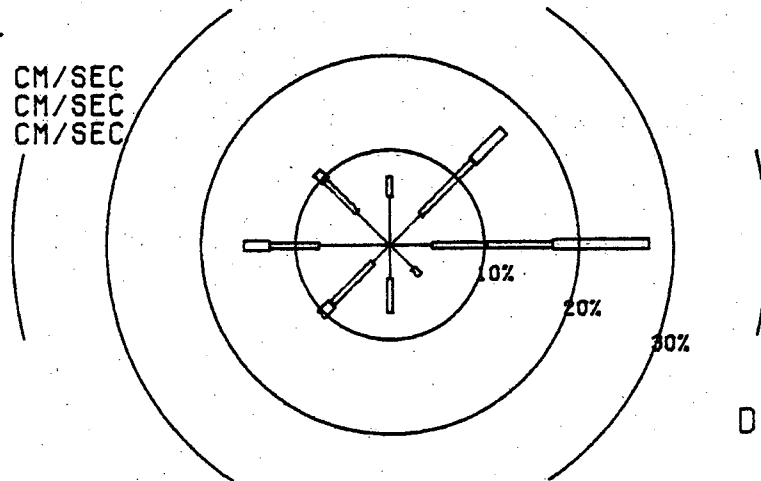

DEPTH: 9 M

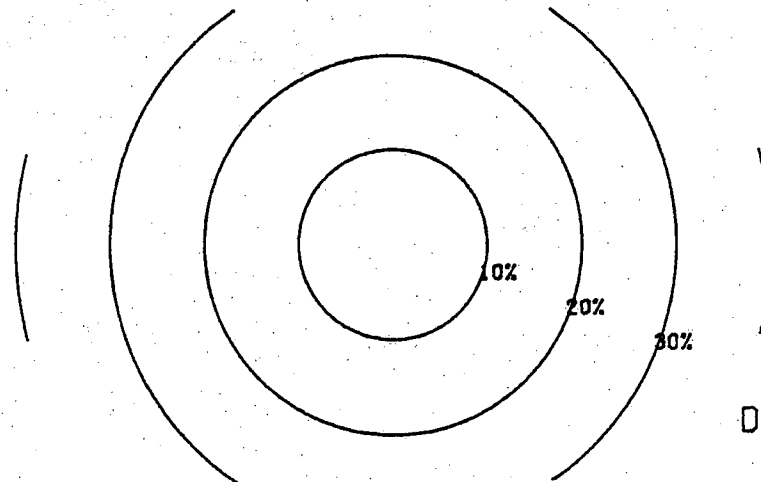

DEPTH: M

\* DIRECTION TOWARDS

MOORING : 26

DATE : JULY 1973

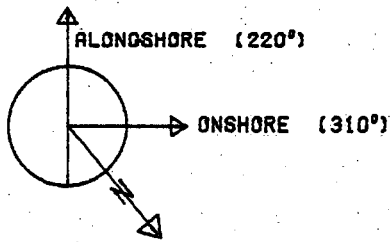

WINDSPEED<sup>2</sup>

0 40 M<sup>2</sup>/SEC<sup>2</sup>

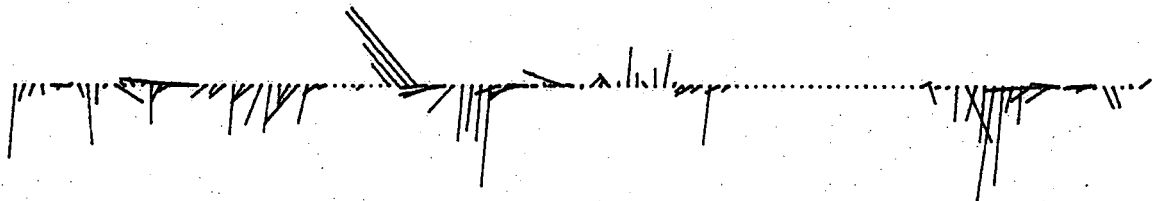

FILTERED CURRENT  
(0.0 TO 0.05 CPH)

DEPTH: 9 M

0 10 CM/SEC

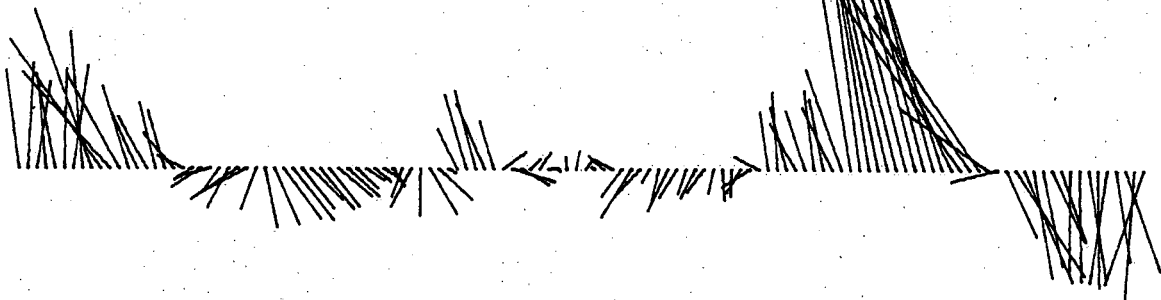

DEPTH: M

1 2 3 4 5 6 7 8 9 10 11 12 13 14 15 16 17 18 19 20 21 22 23 24 25 26 27 28 29 30 31

MOORING: 27      DATE: JULY 1973  
 MONTHLY SUMMARY: WIND AND CURRENT\*

WIND  
 — 0-3 M/SEC  
 = 3-7 M/SEC  
 ≡ ≥ 7 M/SEC

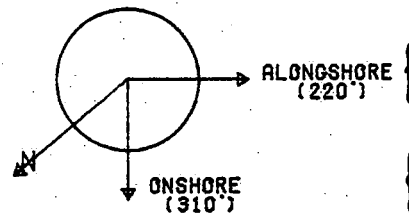
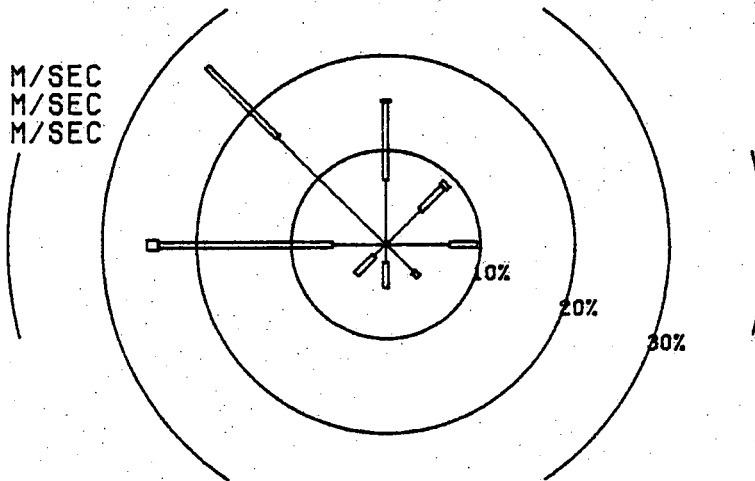

CURRENT  
 — 0-5 CM/SEC  
 = 5-15 CM/SEC  
 ≡ ≥ 15 CM/SEC

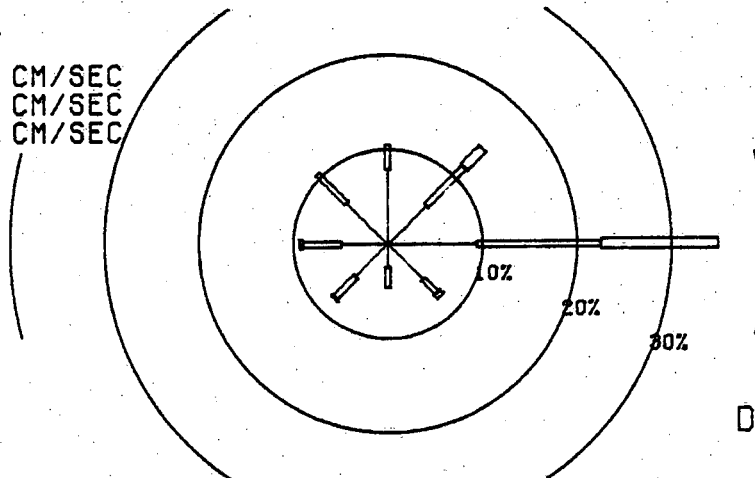

DEPTH: 9 M

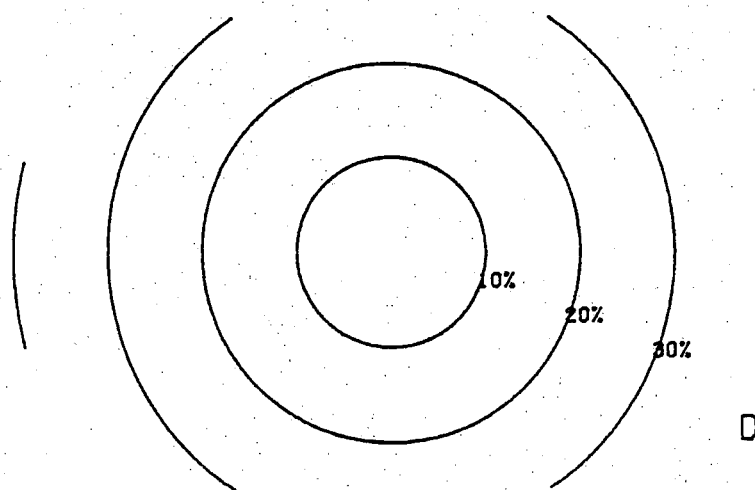

DEPTH: M

\* DIRECTION TOWARDS

MOORING : 27

DATE : JULY 1973

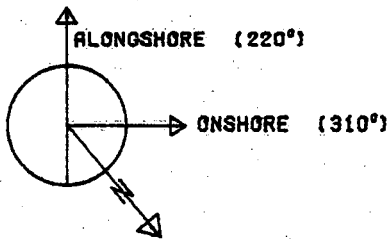

WINDSPEED<sup>2</sup>

0 40 M<sup>2</sup>/SEC<sup>2</sup>

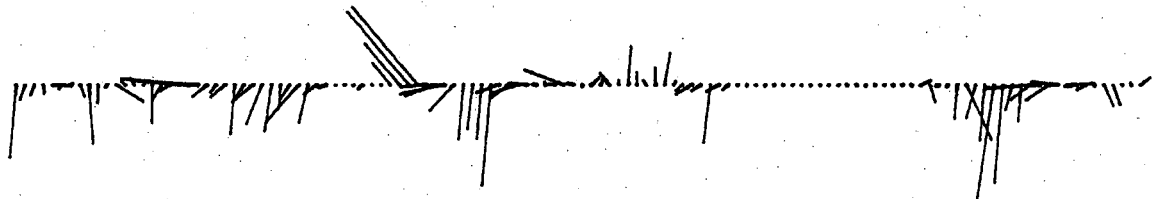

FILTERED CURRENT  
(0.0 TO 0.05 CPH)

DEPTH: 9 M

0 10 CM/SEC

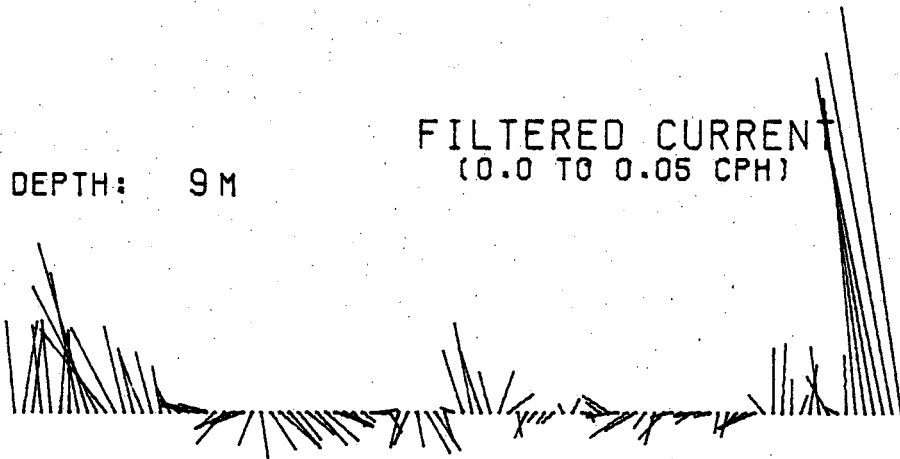

DEPTH: M

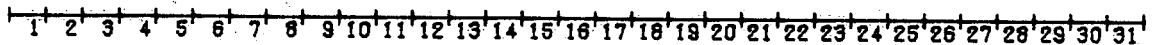

MOORING: 28      DATE: JULY 1973  
 MONTHLY SUMMARY: WIND AND CURRENT\*

WIND  
 — 0-3 M/SEC  
 = 3-7 M/SEC  
 ≡ ≥ 7 M/SEC

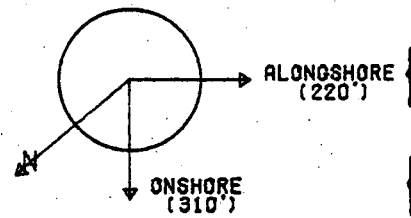
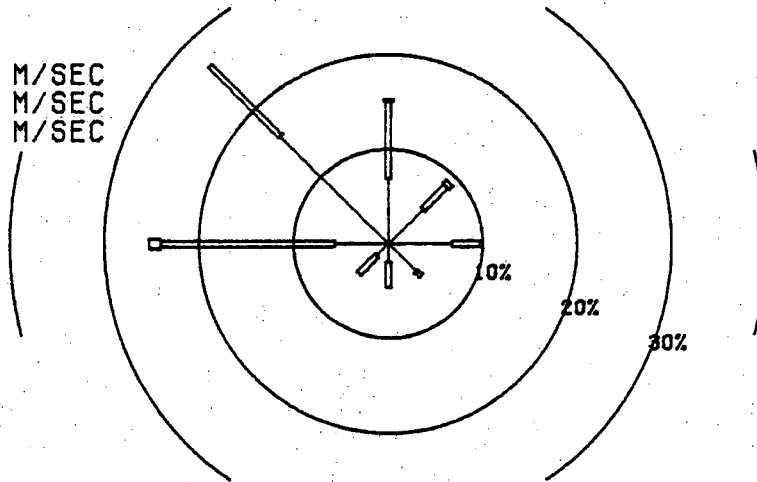

CURRENT  
 — 0-5 CM/SEC  
 = 5-15 CM/SEC  
 ≡ ≥ 15 CM/SEC

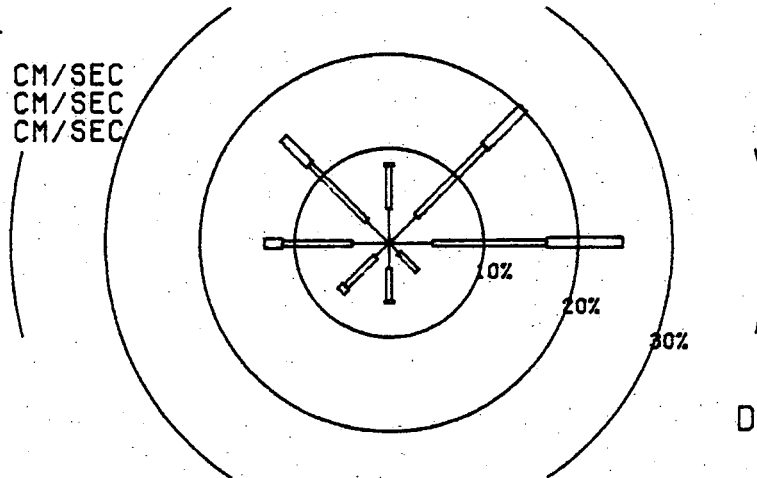

DEPTH: 8 M

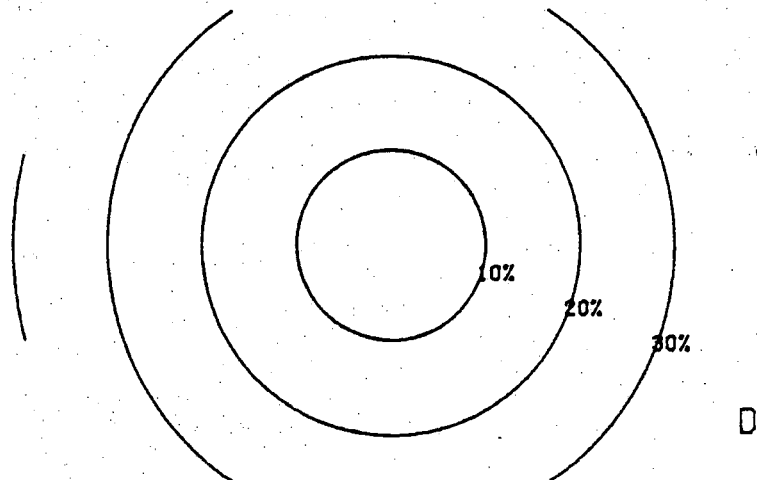

DEPTH: M

\* DIRECTION TOWARDS

MOORING : 28

DATE : JULY 1973

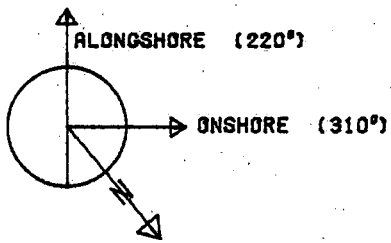

WINDSPEED<sup>2</sup>

0 40 M<sup>2</sup>/SEC<sup>2</sup>

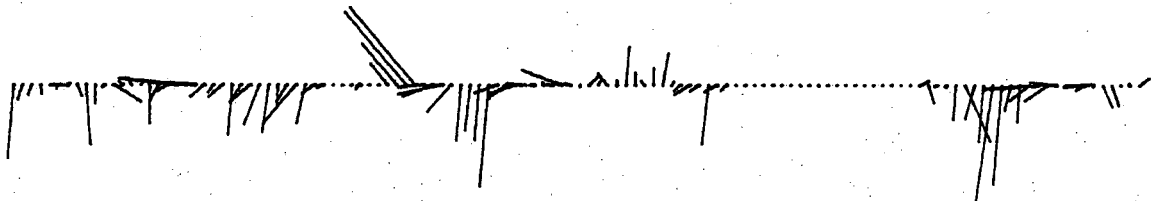

DEPTH: 8 M

FILTERED CURRENT  
(0.0 TO 0.05 CPH)

0 10 CM/SEC

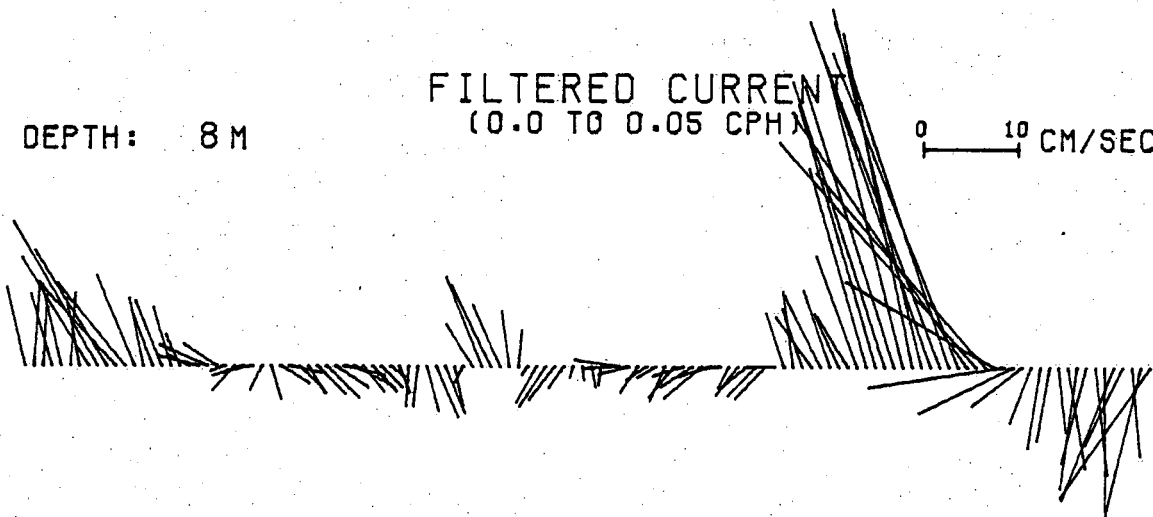

DEPTH: M

1' 2' 3' 4' 5' 6' 7' 8' 9' 10' 11' 12' 13' 14' 15' 16' 17' 18' 19' 20' 21' 22' 23' 24' 25' 26' 27' 28' 29' 30' 31'

# METEOROLOGICAL DATA

MOORING: BURLINGTON DATE: AUG 1973

FILTERED WIND (0.0 TO 0.05 CPH)

0 10 M/SEC

N  
↑

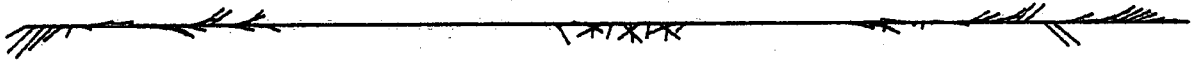

FILTERED WIND (0.0 TO 0.2 CPH) \*

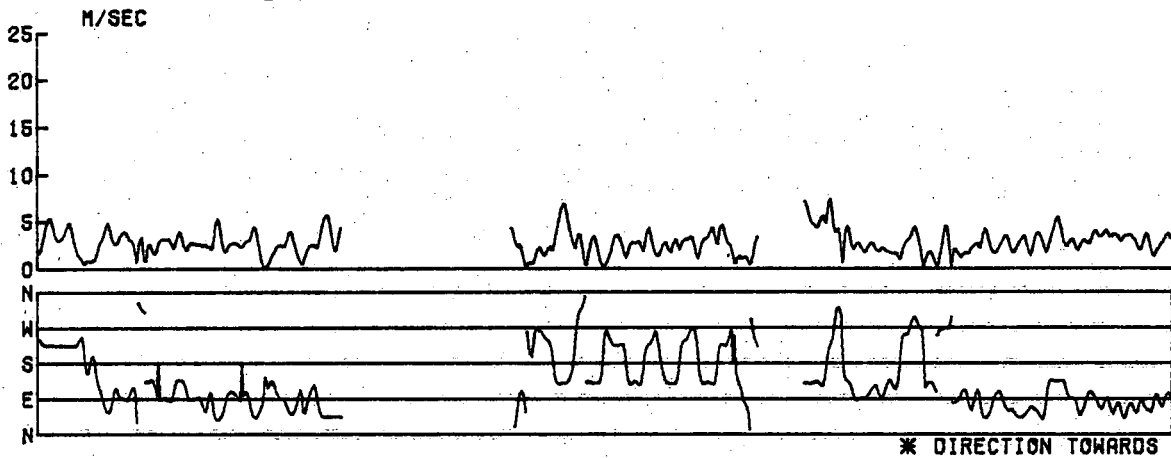

TEMPERATURE °C

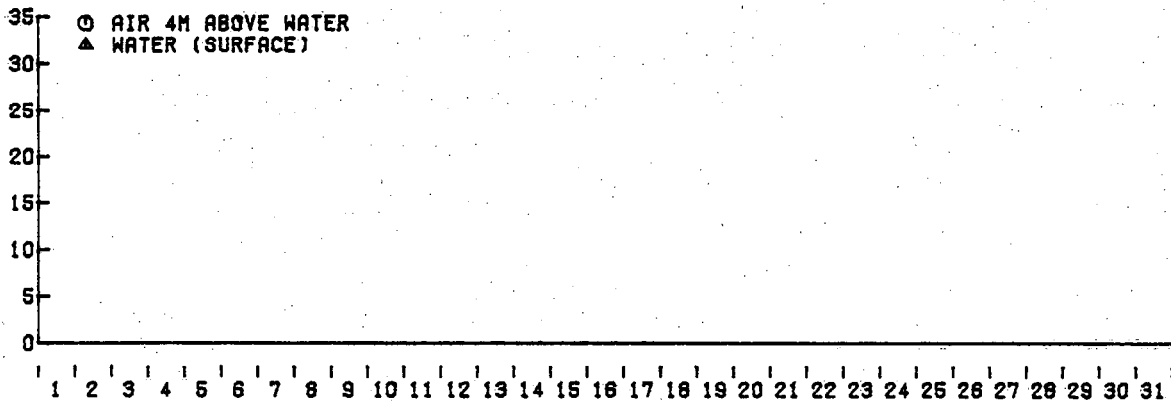

## DAILY MAXIMUM AND MINIMUM AIR TEMPERATURE

DAY	TMAX	TMIN	DAY	TMAX	TMIN	DAY	TMAX	TMIN	DAY	TMAX	TMIN
1			9			17			25		
2			10			18			26		
3			11			19			27		
4			12			20			28		
5			13			21			29		
6			14			22			30		
7			15			23			31		
8			16			24					

MOORING: 21      DATE: AUG 1973  
 MONTHLY SUMMARY: WIND AND CURRENT\*

WIND  
 — 0-3 M/SEC  
 = 3-7 M/SEC  
 ≡ ≥ 7 M/SEC

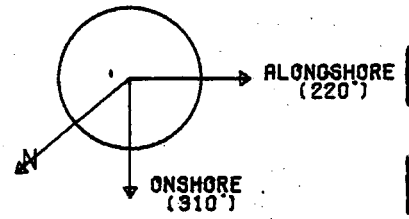
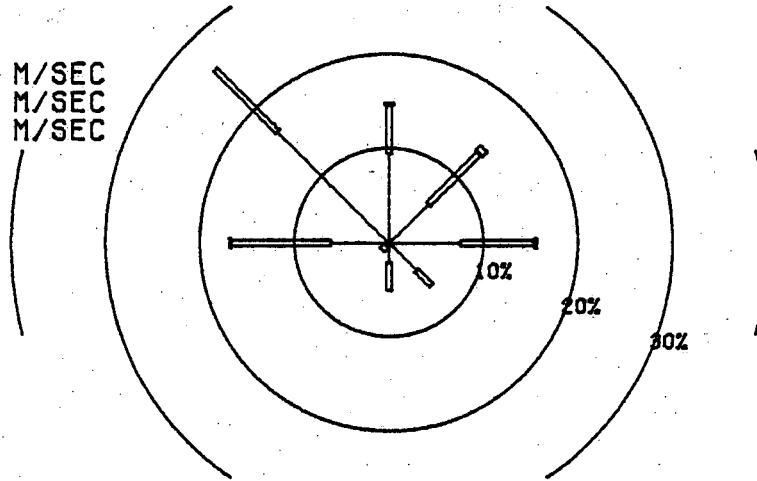

CURRENT  
 — 0-5 CM/SEC  
 = 5-15 CM/SEC  
 ≡ ≥ 15 CM/SEC

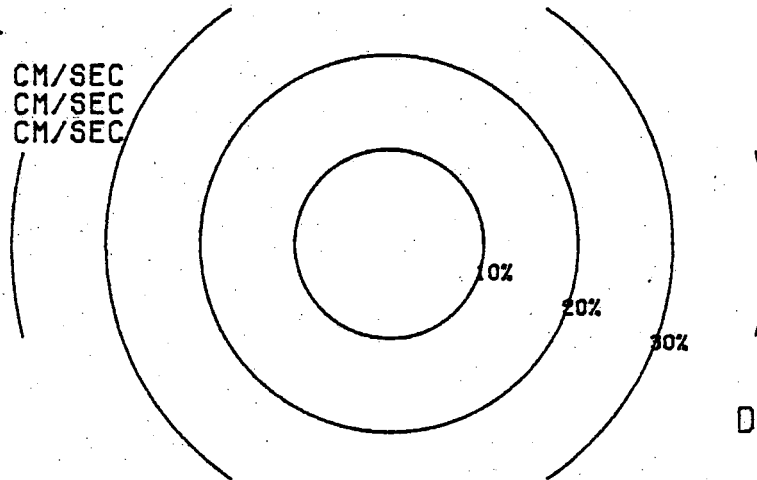

DEPTH: 0 M

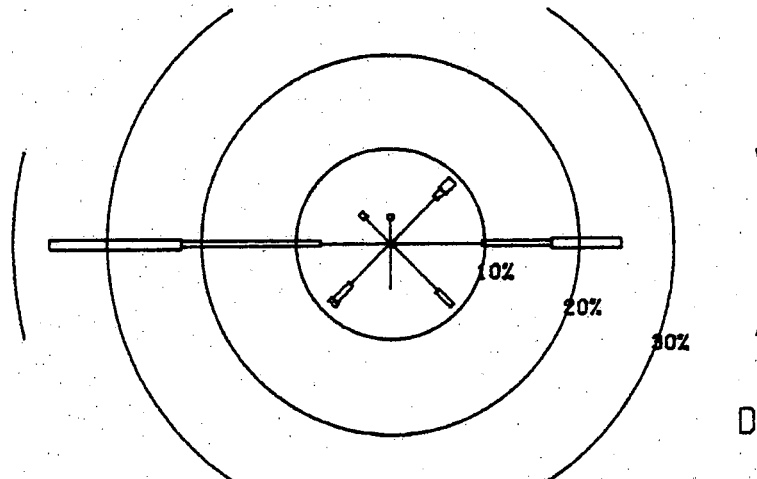

DEPTH: 16 M

\* DIRECTION TOWARDS



MOORING : 21

DATE : AUG 1973

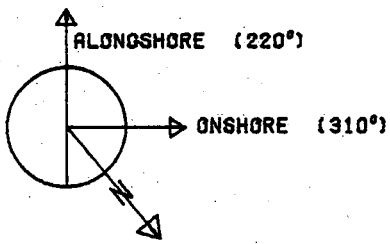

WINDSPEED<sup>2</sup>

0 40 M<sup>2</sup>/SEC<sup>2</sup>

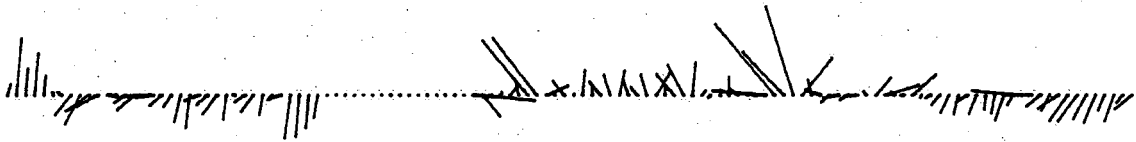

FILTERED CURRENT  
(0.0 TO 0.05 CPH)

DEPTH: M

0 10 CM/SEC

DEPTH: 16 M

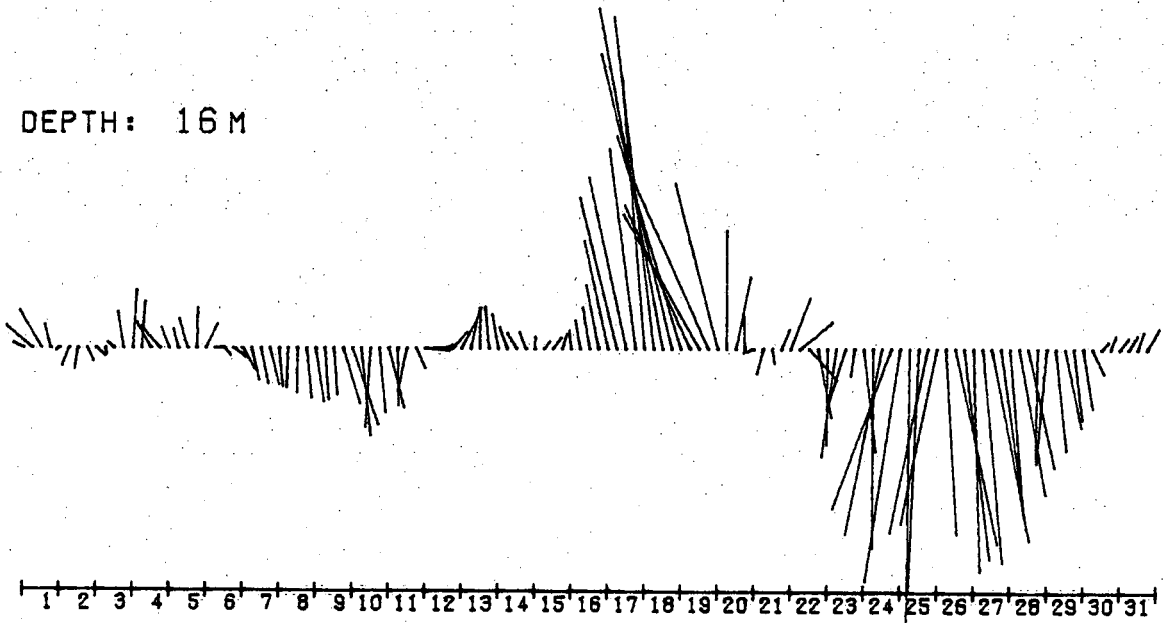

1 2 3 4 5 6 7 8 9 10 11 12 13 14 15 16 17 18 19 20 21 22 23 24 25 26 27 28 29 30 31

MOORING: 22      DATE: AUG 1973  
 MONTHLY SUMMARY: WIND AND CURRENT\*

WIND  
 — 0-3 M/SEC  
 = 3-7 M/SEC  
 ≡ ≥ 7 M/SEC

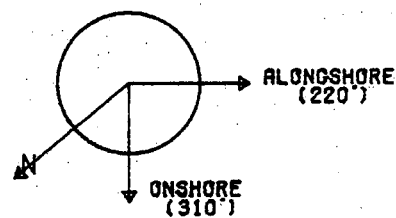
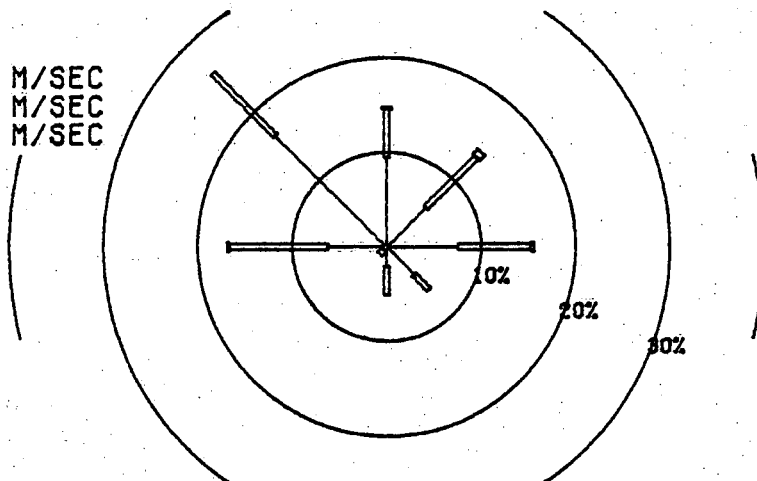

CURRENT  
 — 0-5 CM/SEC  
 = 5-15 CM/SEC  
 ≡ ≥ 15 CM/SEC

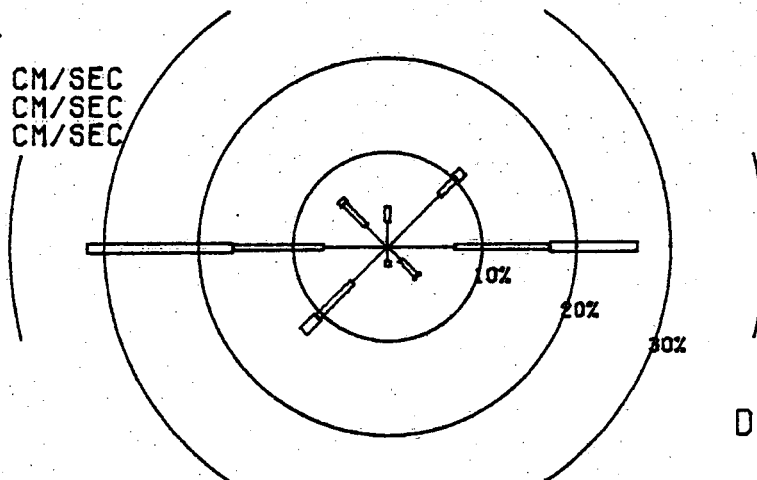

DEPTH: 9 M

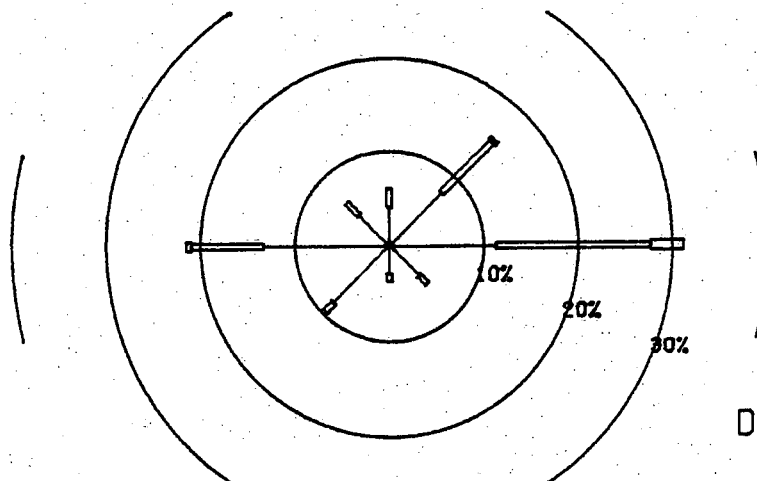

DEPTH: 27 M

\* DIRECTION TOWARDS

MOORING: 22

DATE: AUG 1973

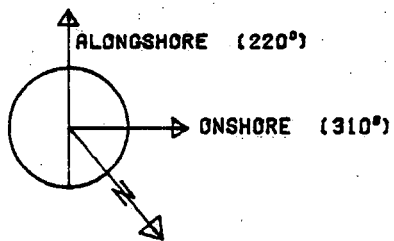

WINDSPEED<sup>2</sup>

0 40 M<sup>2</sup>/SEC<sup>2</sup>

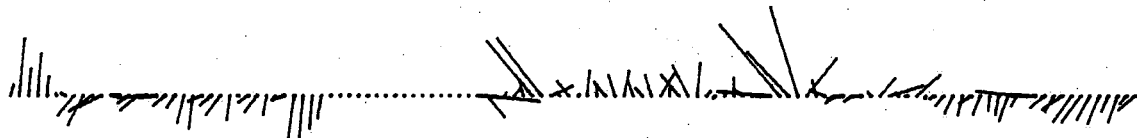

FILTERED CURRENT  
(0.0 TO 0.05 CPH)

DEPTH: 9 M

0 10 CM/SEC

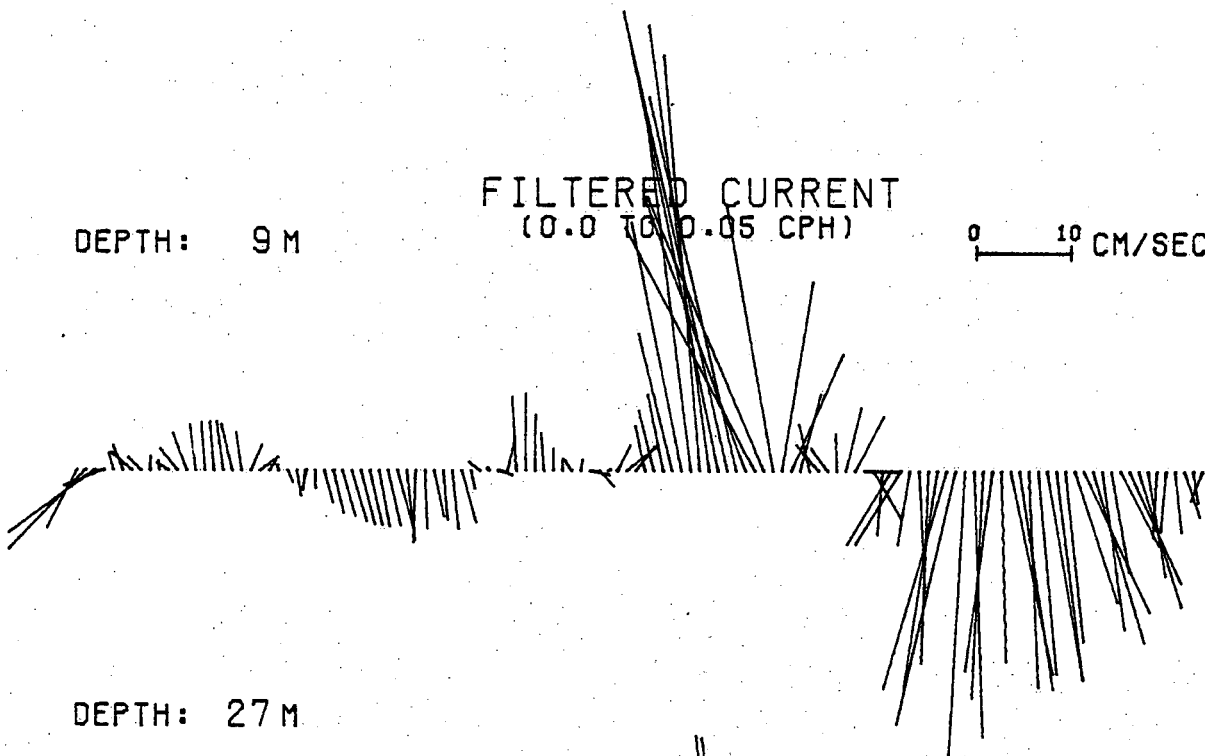

DEPTH: 27 M

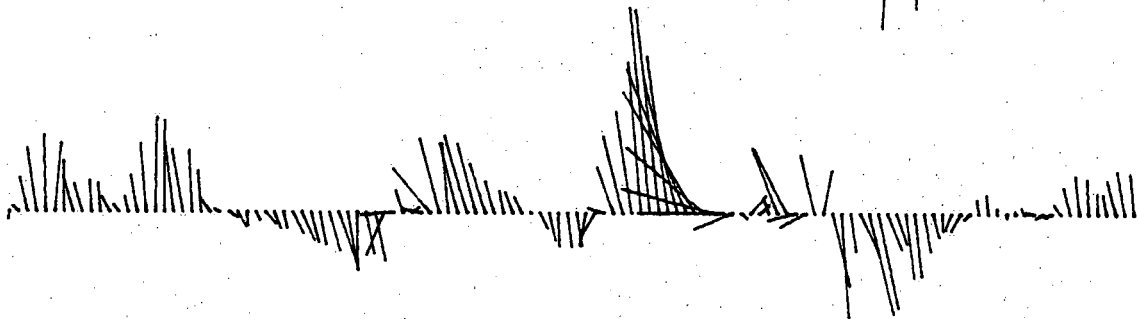

1 2 3 4 5 6 7 8 9 10 11 12 13 14 15 16 17 18 19 20 21 22 23 24 25 26 27 28 29 30 31

MOORING: 23      DATE: AUG 1973  
 MONTHLY SUMMARY: WIND AND CURRENT\*

WIND  
 — 0-3 M/SEC  
 = 3-7 M/SEC  
 ≡ ≥ 7 M/SEC

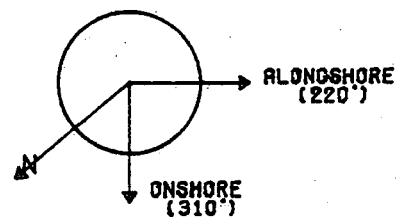
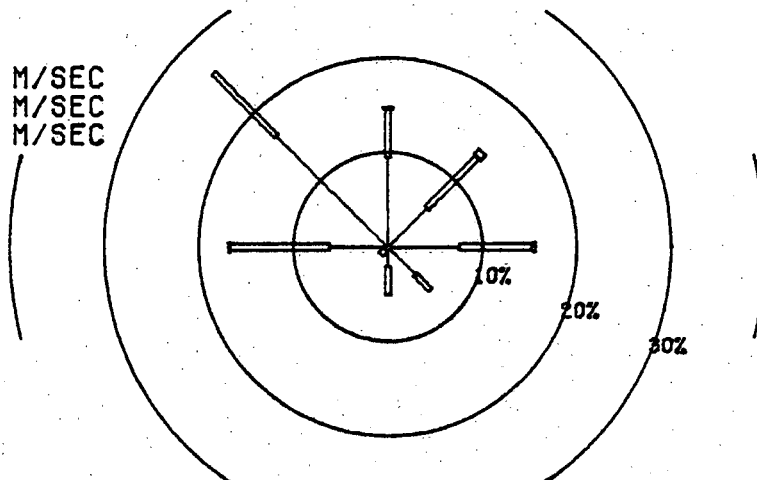

CURRENT  
 — 0-5 CM/SEC  
 = 5-15 CM/SEC  
 ≡ ≥ 15 CM/SEC

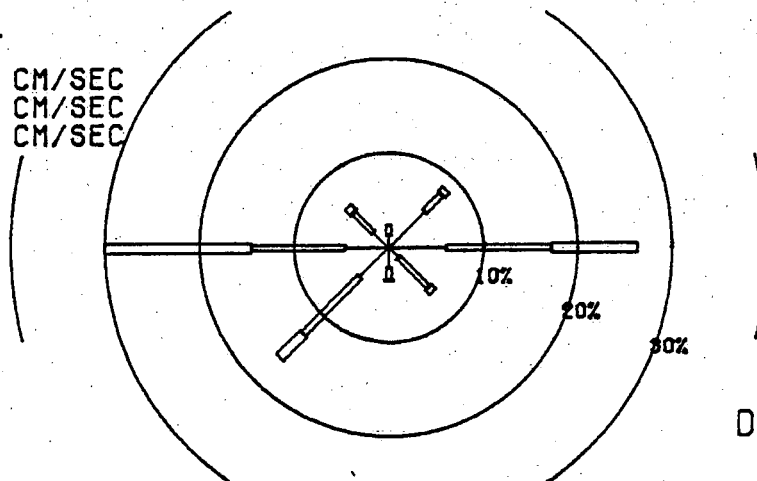

DEPTH: 9 M

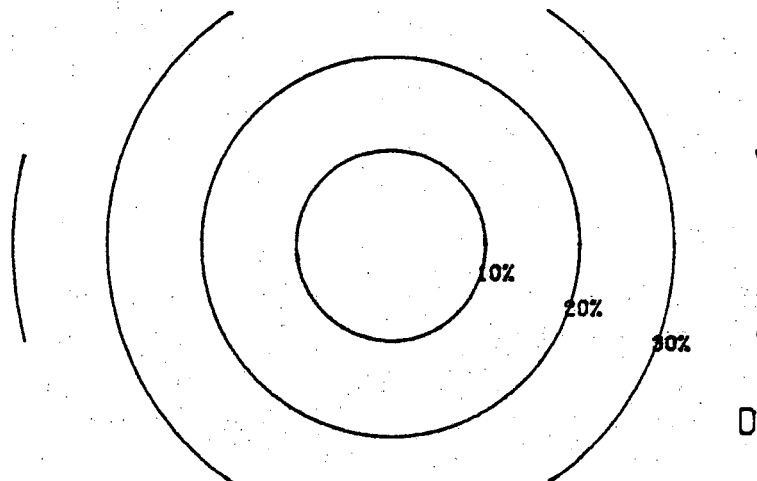

DEPTH: M

\* DIRECTION TOWARDS

MOORING: 23

DATE: AUG 1973

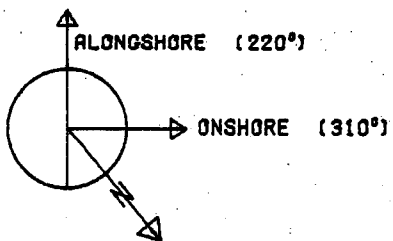

WINDSPEED<sup>2</sup>

0 40 M<sup>2</sup>/SEC<sup>2</sup>

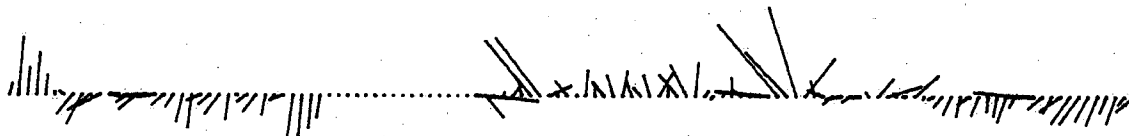

FILTERED CURRENT  
(0.0 TO 0.05 CPH)

DEPTH: 9 M

0 10 CM/SEC

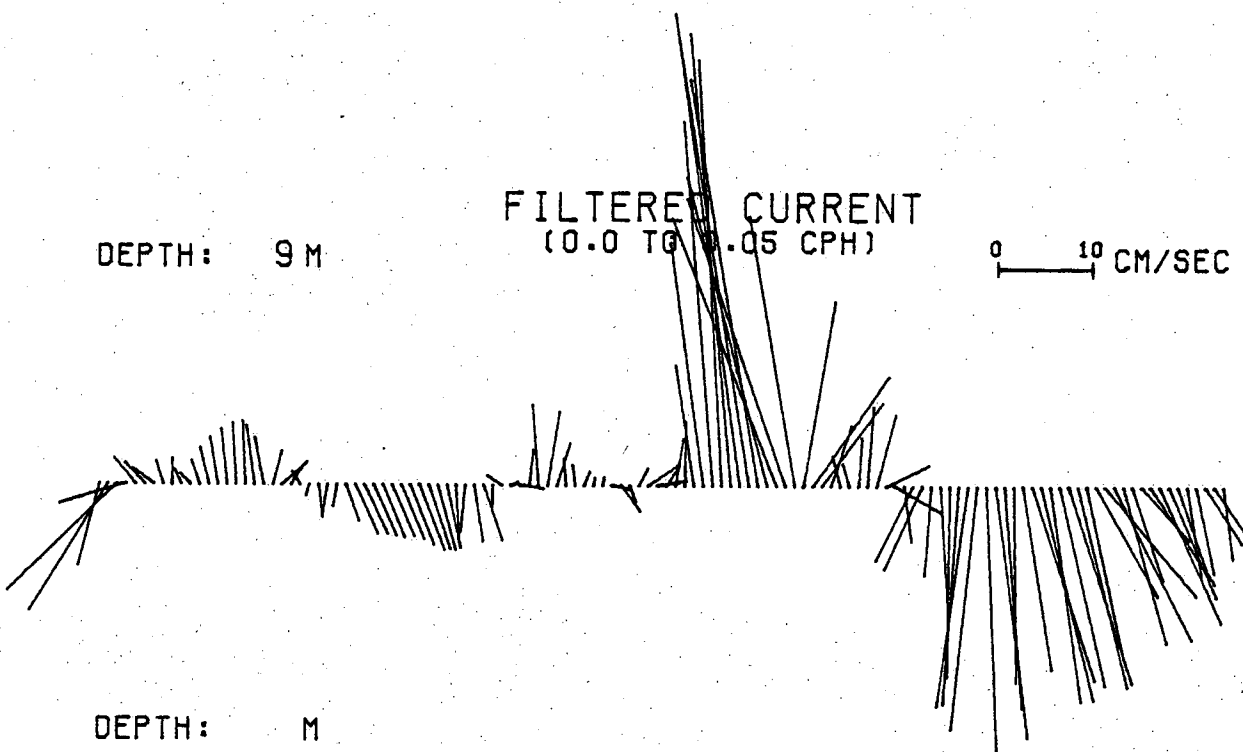

DEPTH: M

1 2 3 4 5 6 7 8 9 10 11 12 13 14 15 16 17 18 19 20 21 22 23 24 25 26 27 28 29 30 31

MOORING: 25      DATE: AUG 1973  
 MONTHLY SUMMARY: WIND AND CURRENT\*

WIND  
 — 0-3 M/SEC  
 = 3-7 M/SEC  
 ≡ ≥ 7 M/SEC

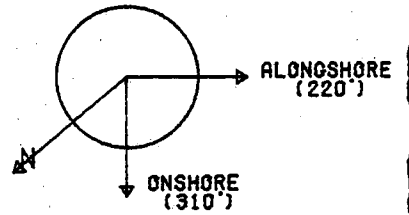
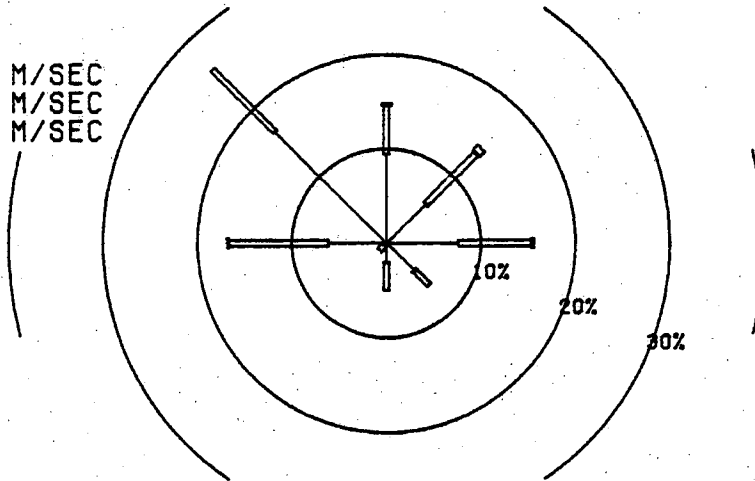

CURRENT  
 — 0-5 CM/SEC  
 = 5-15 CM/SEC  
 ≡ ≥ 15 CM/SEC

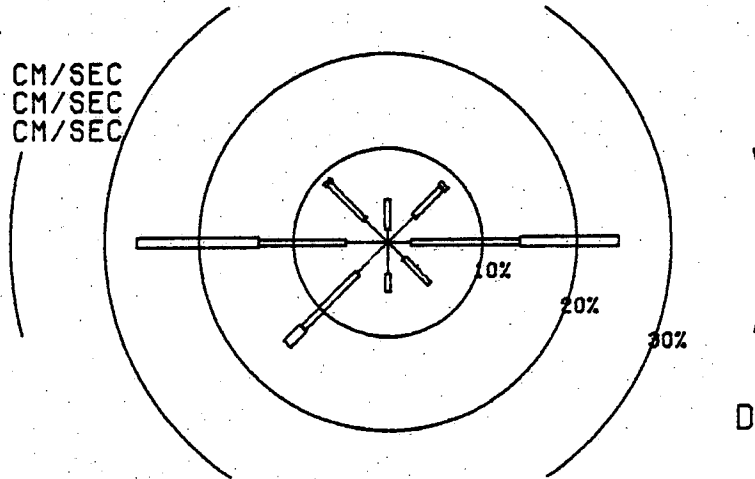

DEPTH: 9 M

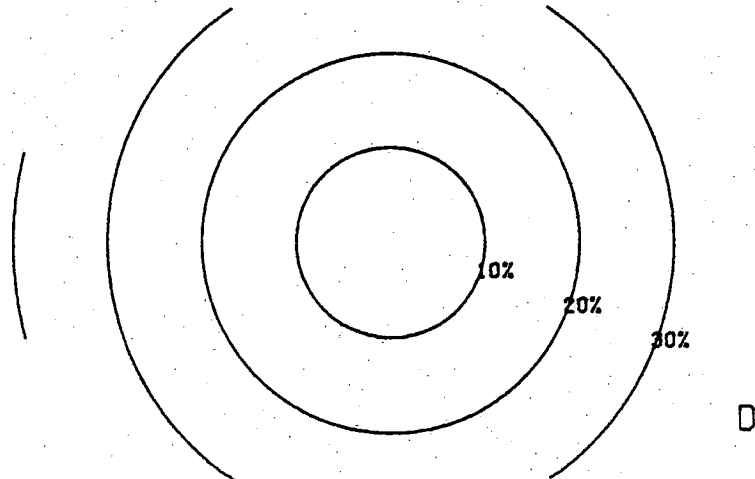

DEPTH: M

\* DIRECTION TOWARDS

MOORING : 25

DATE : AUG 1973

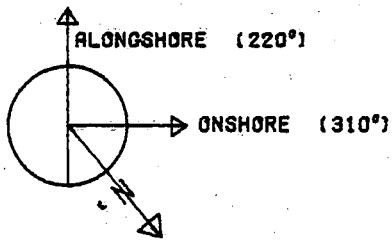

WINDSPEED<sup>2</sup>

0 40 M<sup>2</sup>/SEC<sup>2</sup>

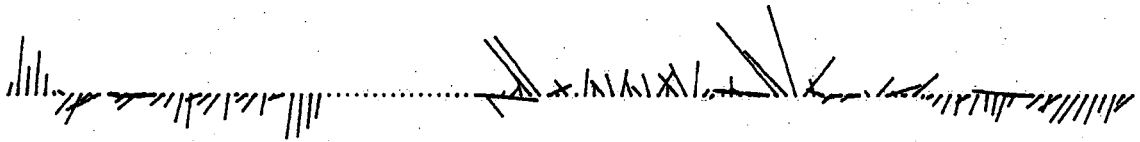

FILTERED CURRENT  
(0.0 TO 0.05 CPH)

DEPTH: 9 M

0 10 CM/SEC

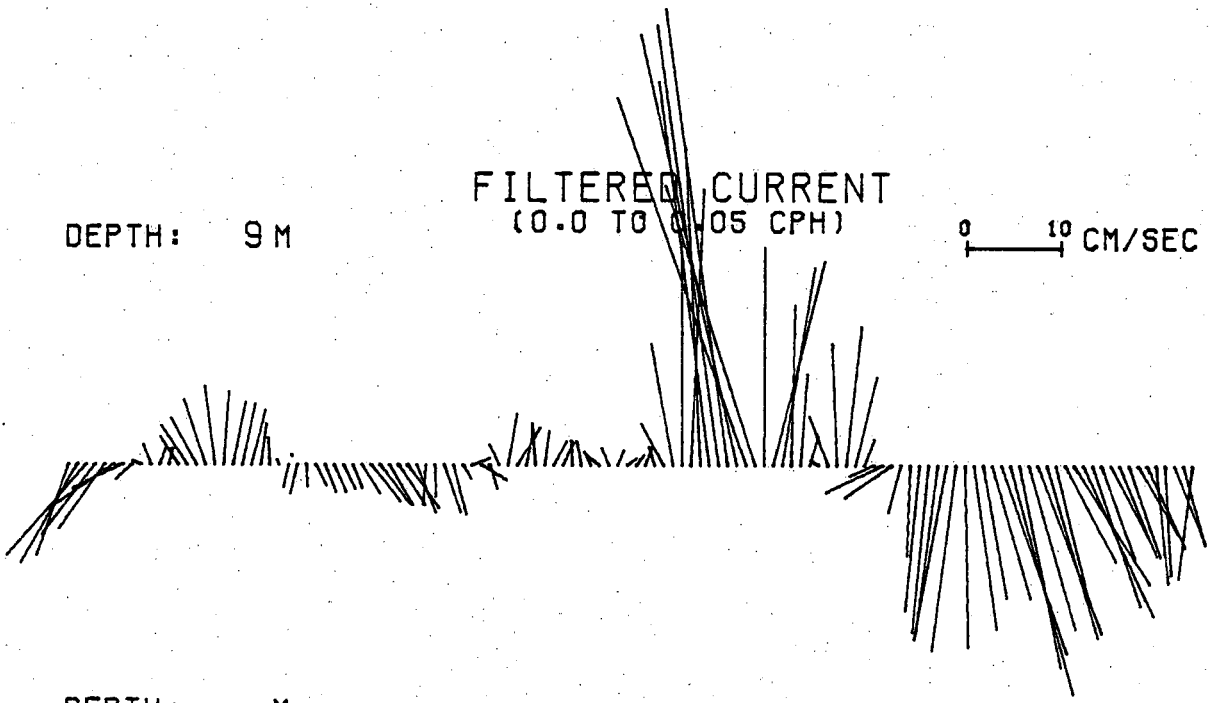

DEPTH: M

1 2 3 4 5 6 7 8 9 10 11 12 13 14 15 16 17 18 19 20 21 22 23 24 25 26 27 28 29 30 31

MOORING: 26      DATE: AUG 1973  
 MONTHLY SUMMARY: WIND AND CURRENT\*

WIND  
 — 0-3 M/SEC  
 = 3-7 M/SEC  
 ≡ ≥ 7 M/SEC

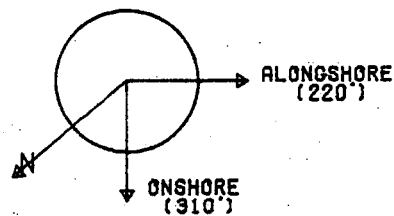
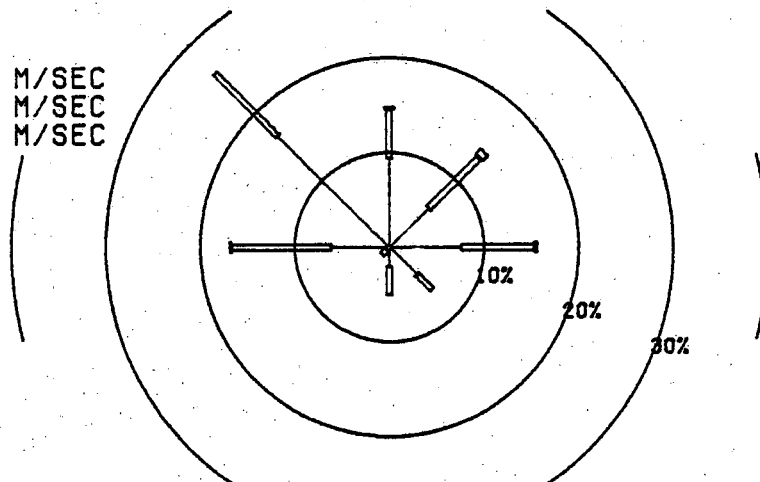

CURRENT  
 — 0-5 CM/SEC  
 = 5-15 CM/SEC  
 ≡ ≥ 15 CM/SEC

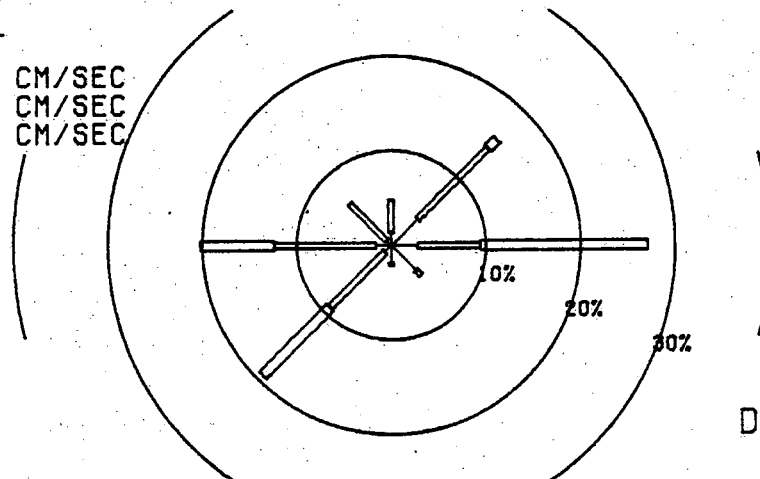

DEPTH: 9 M

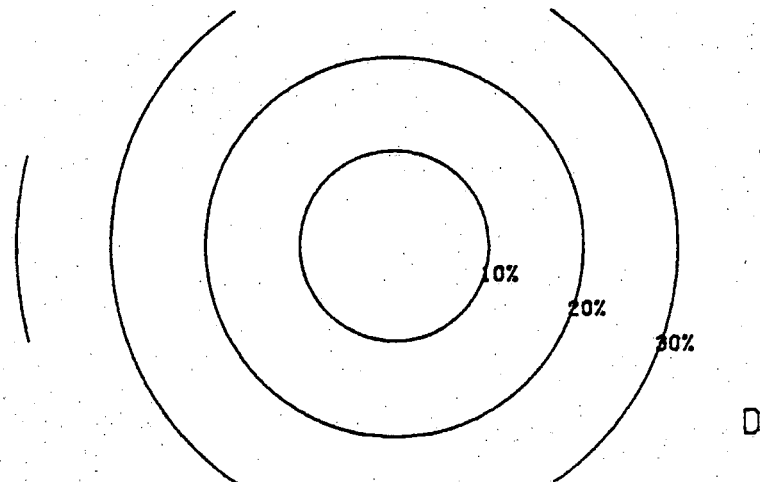

DEPTH: M

\* DIRECTION TOWARDS



MOORING : 26

DATE : AUG 1973

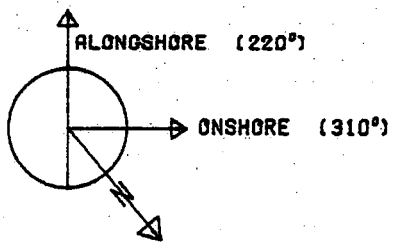

WINDSPEED<sup>2</sup>

0 40 M<sup>2</sup>/SEC<sup>2</sup>

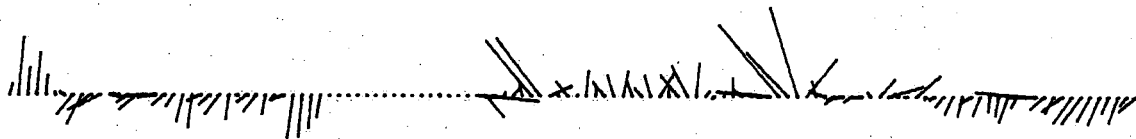

DEPTH: 9 M

FILTERED CURRENT  
(0.0 TO 0.05 CPH)

0 10 CM/SEC

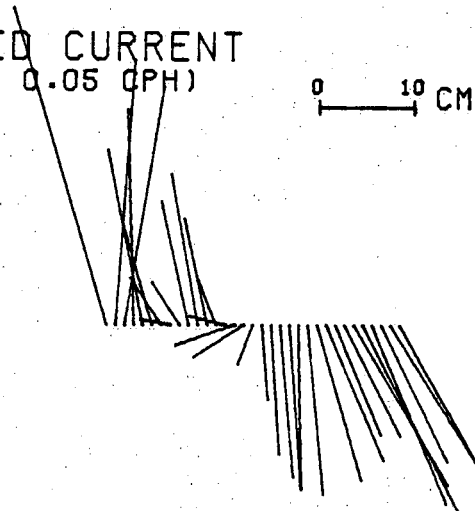

DEPTH: M

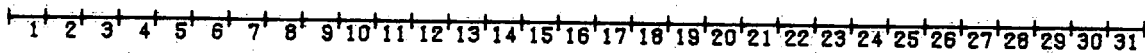

MOORING: 27      DATE: AUG 1973  
 MONTHLY SUMMARY: WIND AND CURRENT\*

WIND  
 — 0-3 M/SEC  
 = 3-7 M/SEC  
 ≡ ≥ 7 M/SEC

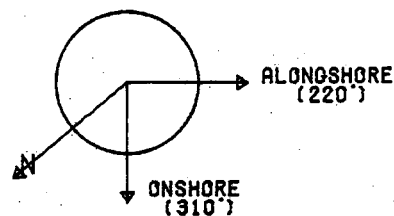
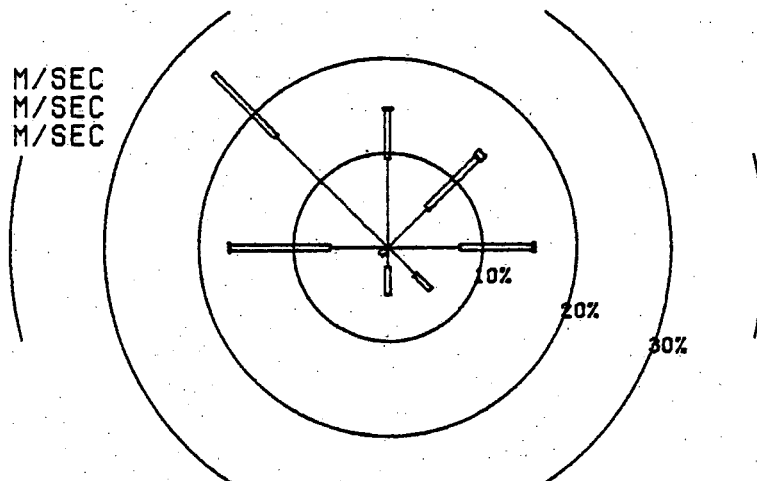

CURRENT  
 — 0-5 CM/SEC  
 = 5-15 CM/SEC  
 ≡ ≥ 15 CM/SEC

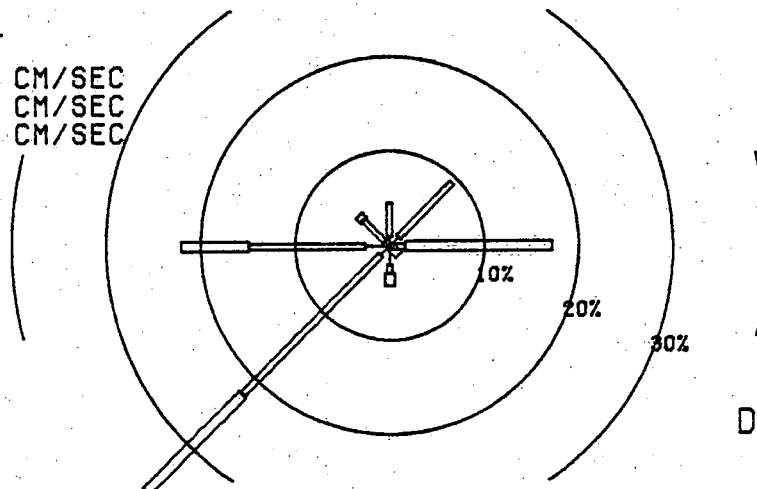

DEPTH: 9 M

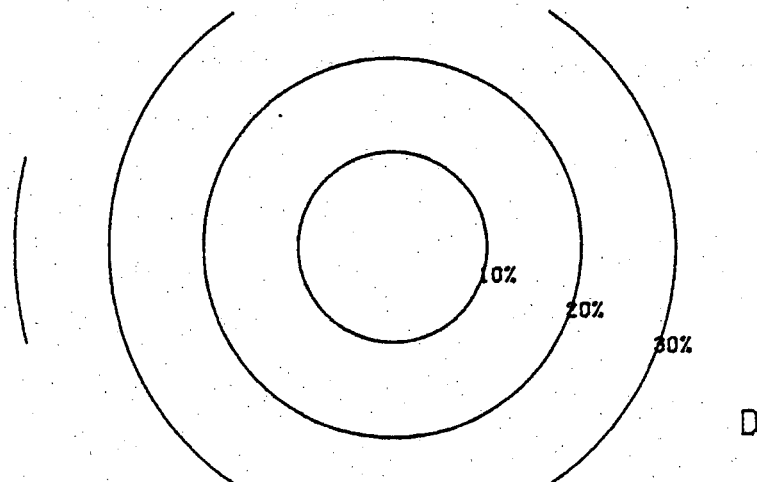

DEPTH: M

\* DIRECTION TOWARDS

MOORING : 27

DATE : AUG 1973

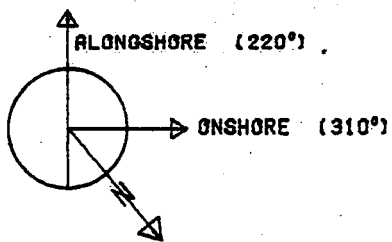

WINDSPEED<sup>2</sup>

0 40 M<sup>2</sup>/SEC<sup>2</sup>

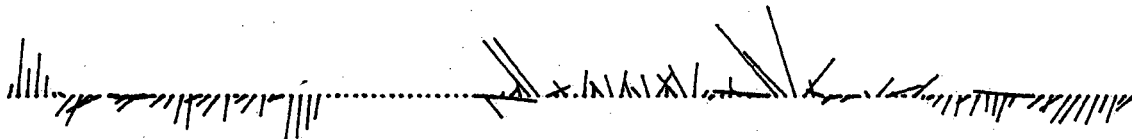

DEPTH: 9 M

FILTERED CURRENT  
(0.0 TO 0.05 CPH)

0 10 CM/SEC

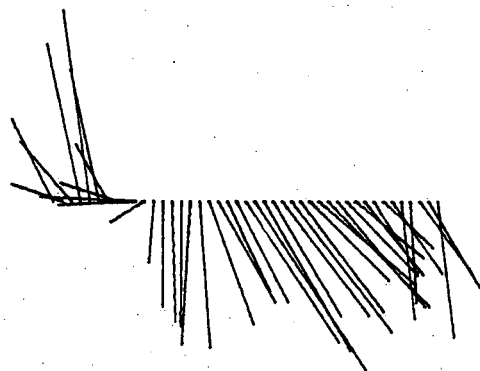

DEPTH: M

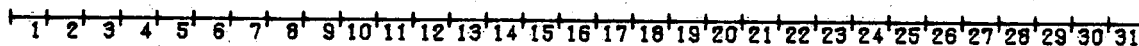

MOORING: 28      DATE: AUG 1973  
 MONTHLY SUMMARY: WIND AND CURRENT\*

WIND  
 — 0-3 M/SEC  
 = 3-7 M/SEC  
 ≡ ≥ 7 M/SEC

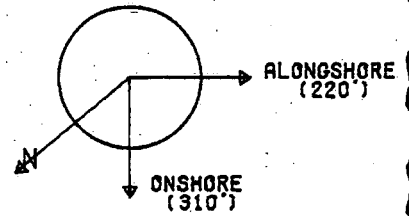
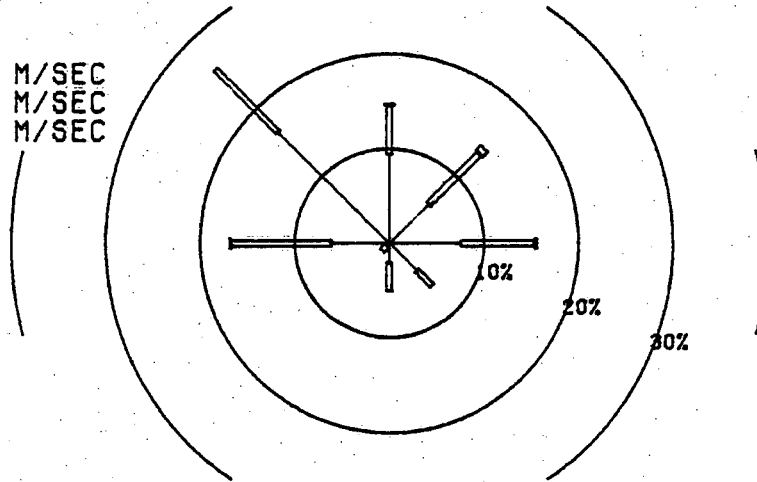

CURRENT  
 — 0-5 CM/SEC  
 = 5-15 CM/SEC  
 ≡ ≥ 15 CM/SEC

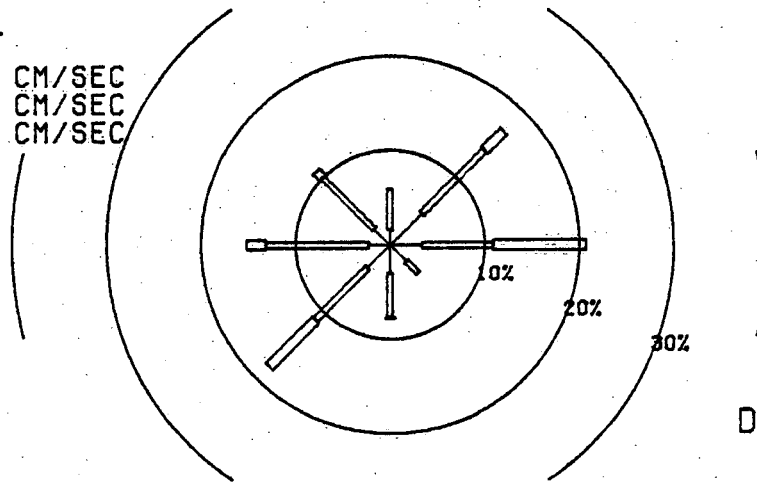

DEPTH: 8 M

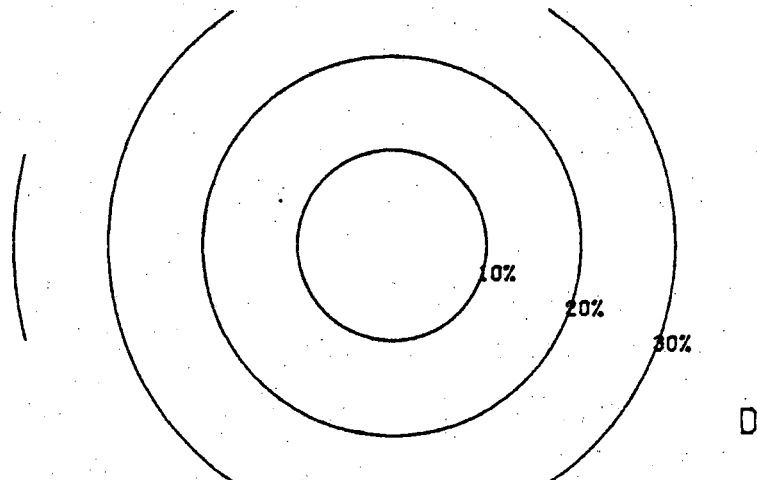

DEPTH: M

\* DIRECTION TOWARDS

MOORING : 28

DATE : AUG 1973

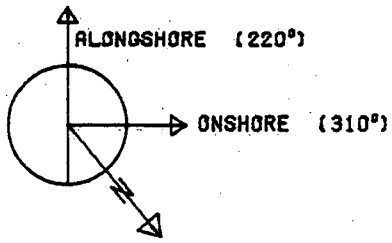

WINDSPEED<sup>2</sup>

0 40 M<sup>2</sup>/SEC<sup>2</sup>

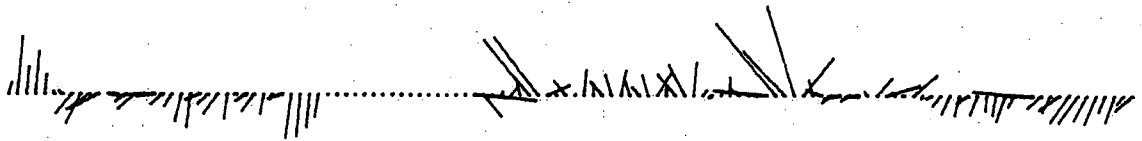

DEPTH: 8 M

FILTERED CURRENT  
(0.0 TO 0.05 CPH)

0 10 CM/SEC

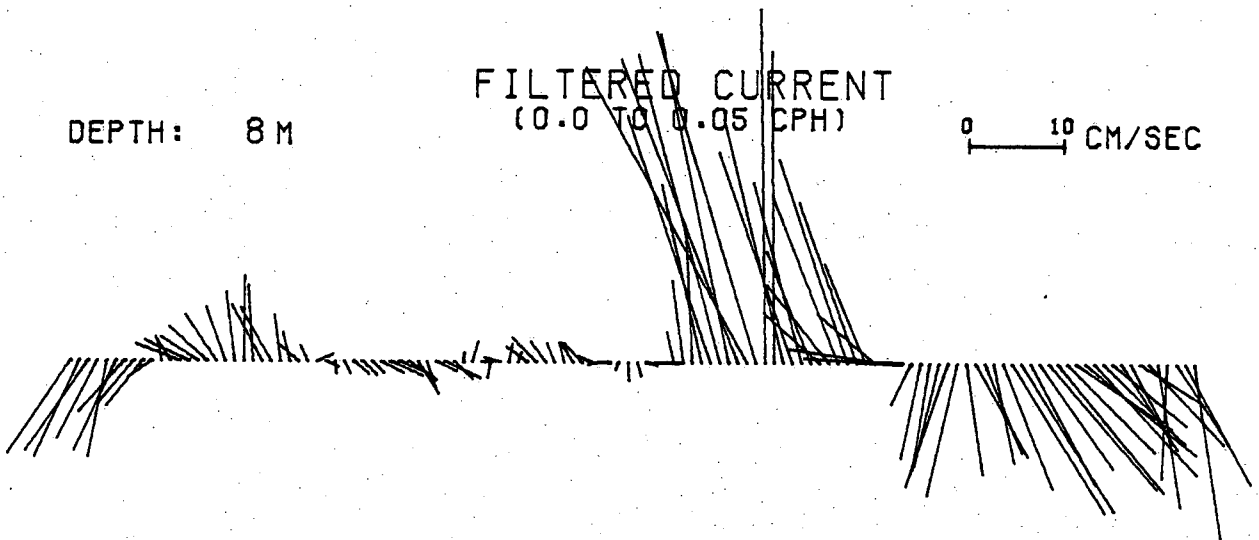

DEPTH: M

1' 2' 3' 4' 5' 6' 7' 8' 9' 10' 11' 12' 13' 14' 15' 16' 17' 18' 19' 20' 21' 22' 23' 24' 25' 26' 27' 28' 29' 30' 31'

# METEOROLOGICAL DATA

MOORING: BURLINGTON DATE: SEPT 1973

FILTERED WIND (0.0 TO 0.05 CPH)

0 10 M/SEC

N  
↑



FILTERED WIND (0.0 TO 0.2 CPH) \*

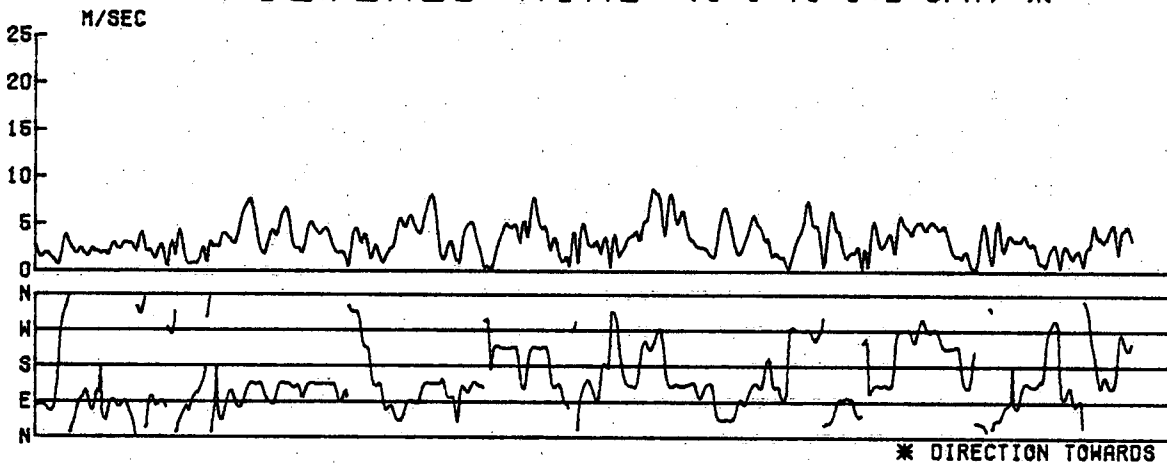

TEMPERATURE °C

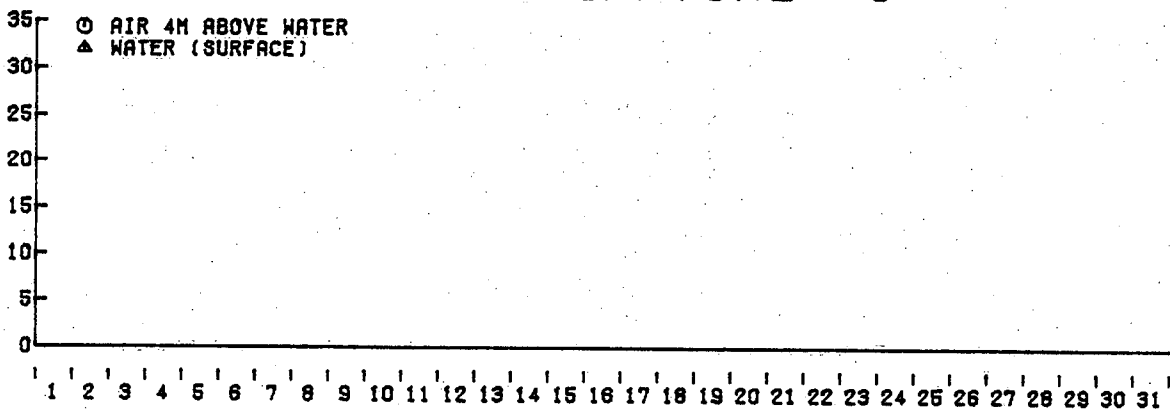

DAILY MAXIMUM AND MINIMUM AIR TEMPERATURE

DAY	TMAX	TMIN	DAY	TMAX	TMIN	DAY	TMAX	TMIN	DAY	TMAX	TMIN
1			9			17			25		
2			10			18			26		
3			11			19			27		
4			12			20			28		
5			13			21			29		
6			14			22			30		
7			15			23			31		
8			16			24					

MOORING: 21      DATE: SEPT 1973  
 MONTHLY SUMMARY: WIND AND CURRENT\*

WIND  
 — 0-3 M/SEC  
 = 3-7 M/SEC  
 ≡ ≥ 7 M/SEC

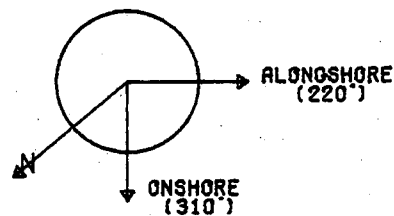
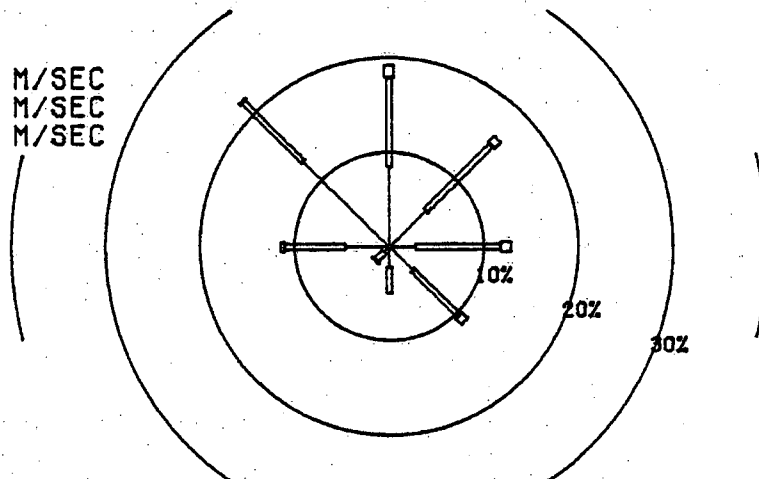

CURRENT  
 — 0-5 CM/SEC  
 = 5-15 CM/SEC  
 ≡ ≥ 15 CM/SEC

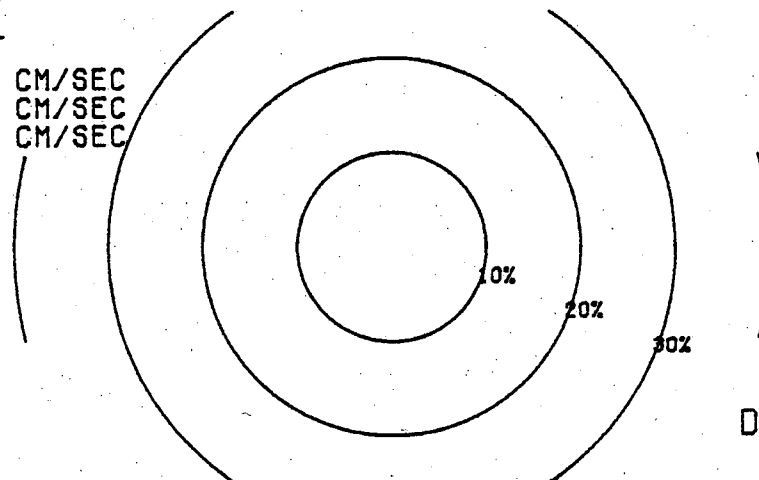

DEPTH: M

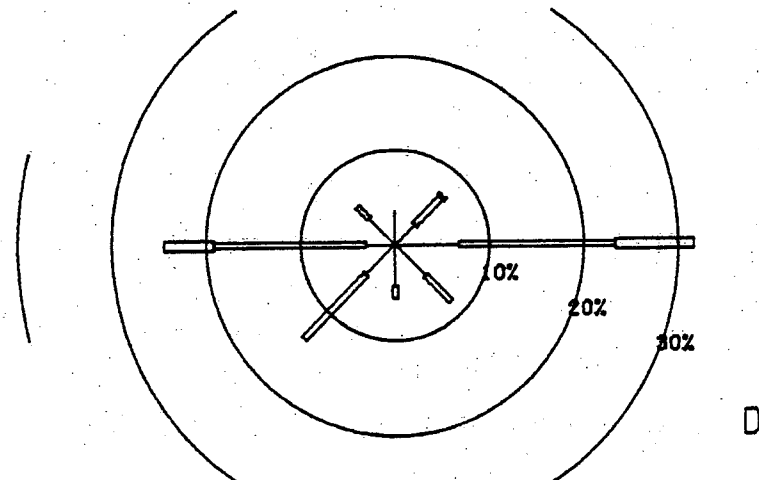

DEPTH: 16 M

\* DIRECTION TOWARDS

MOORING : 21

DATE : SEPT 1973

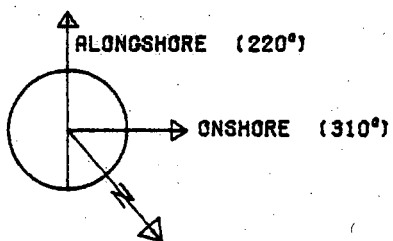

WINDSPEED<sup>2</sup>

0 40 M<sup>2</sup>/SEC<sup>2</sup>

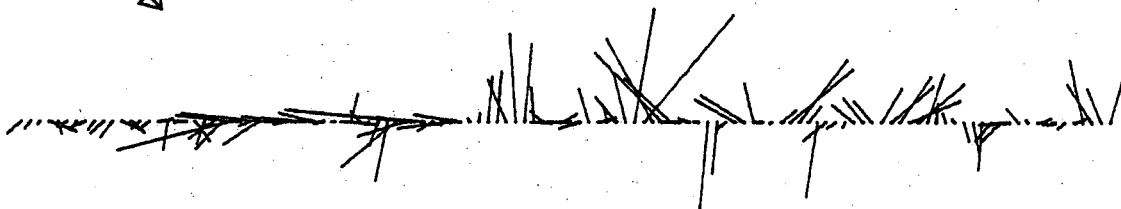

FILTERED CURRENT  
(0.0 TO 0.05 CPH)

DEPTH: M

0 10 CM/SEC

DEPTH: 16 M

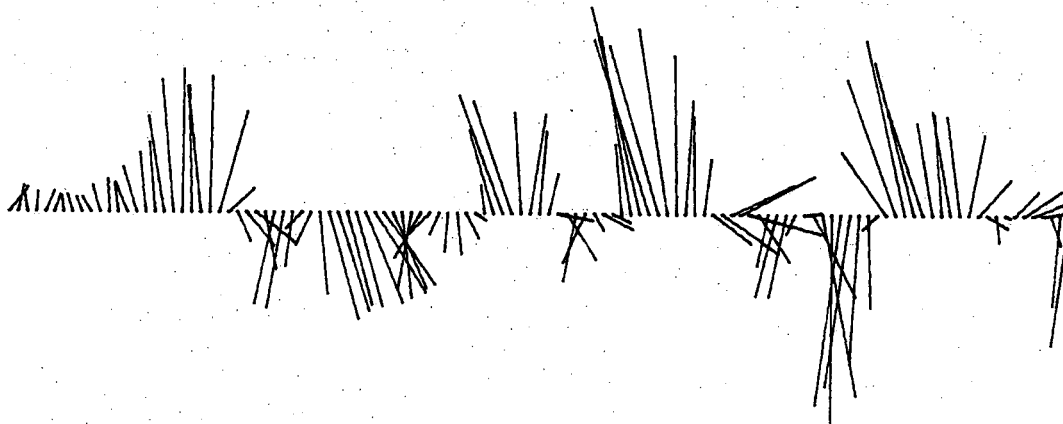

1 2 3 4 5 6 7 8 9 10 11 12 13 14 15 16 17 18 19 20 21 22 23 24 25 26 27 28 29 30 31



MOORING: 22      DATE: SEPT 1973  
 MONTHLY SUMMARY: WIND AND CURRENT\*

WIND  
 — 0-3 M/SEC  
 = 3-7 M/SEC  
 = 7 M/SEC

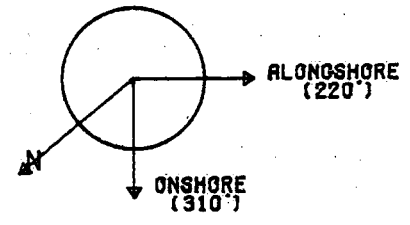
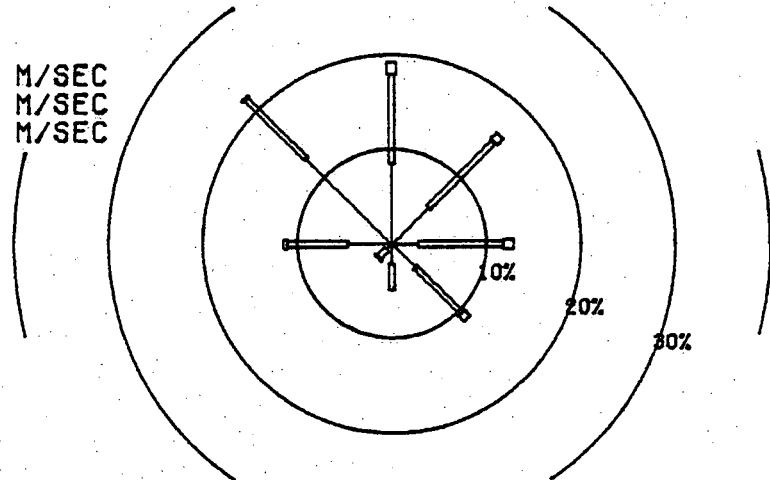

CURRENT  
 — 0-5 CM/SEC  
 = 5-15 CM/SEC  
 = 15 CM/SEC

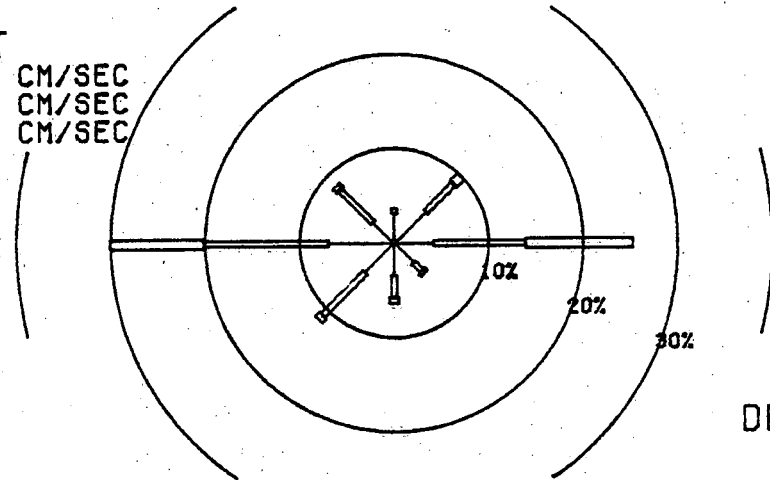

DEPTH: 9 M

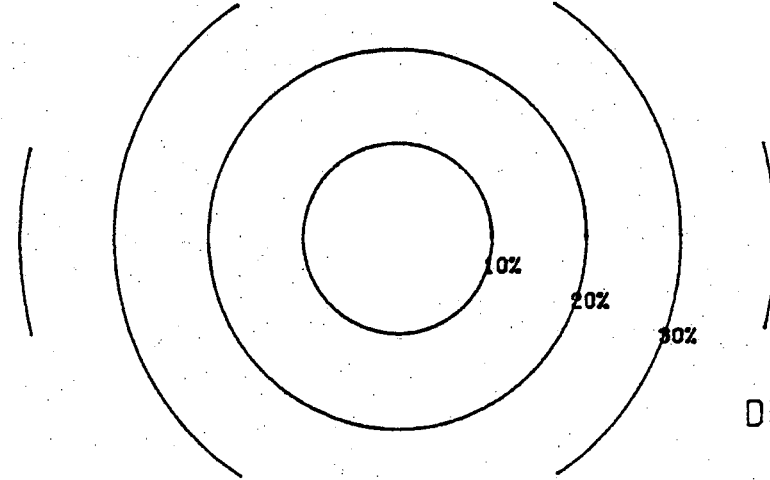

DEPTH: M

\* DIRECTION TOWARDS

MOORING : 22

DATE : SEPT 1973

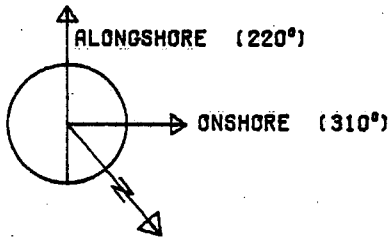

WINDSPEED<sup>2</sup>

0 40 M<sup>2</sup>/SEC<sup>2</sup>

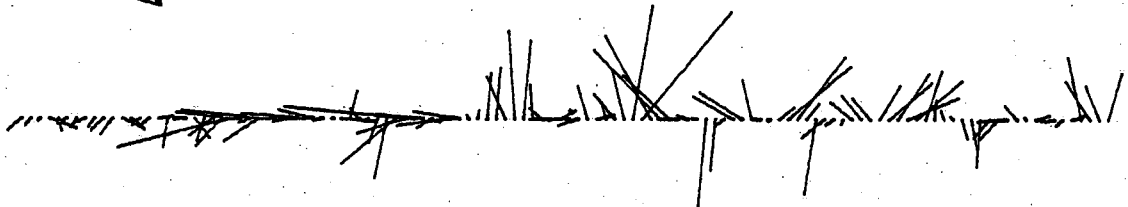

FILTERED CURRENT  
(0.0 TO 0.05 CPH)

DEPTH: 9 M

0 10 CM/SEC

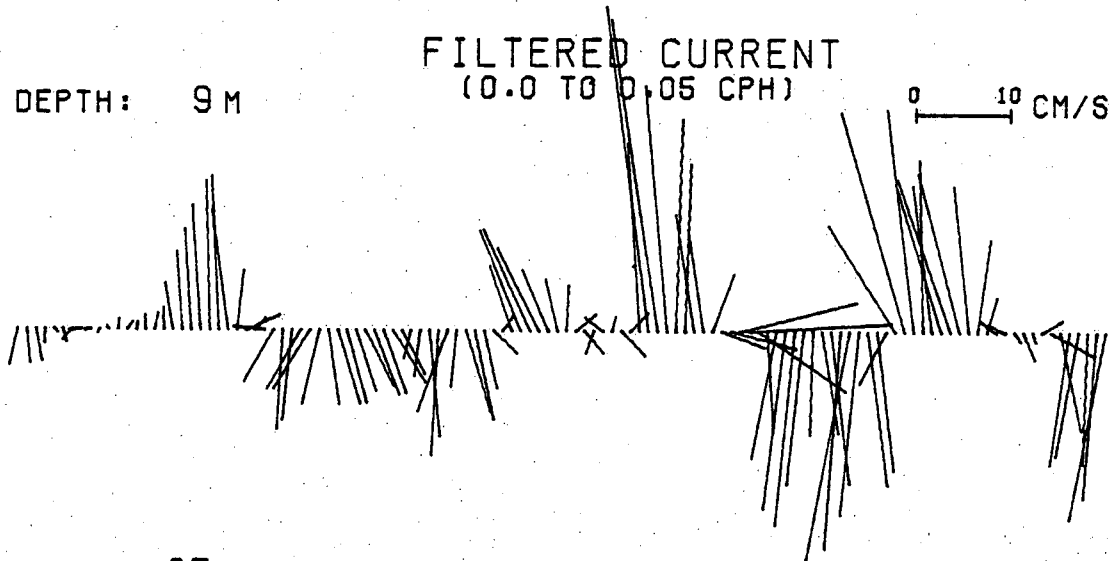

DEPTH: 27 M



1' 2' 3' 4' 5' 6' 7' 8' 9' 10' 11' 12' 13' 14' 15' 16' 17' 18' 19' 20' 21' 22' 23' 24' 25' 26' 27' 28' 29' 30' 31'

MOORING: 23      DATE: SEPT 1973  
 MONTHLY SUMMARY: WIND AND CURRENT\*

WIND  
 — 0-3 M/SEC  
 = 3-7 M/SEC  
 ≡ ≥ 7 M/SEC

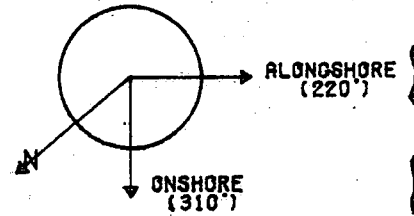
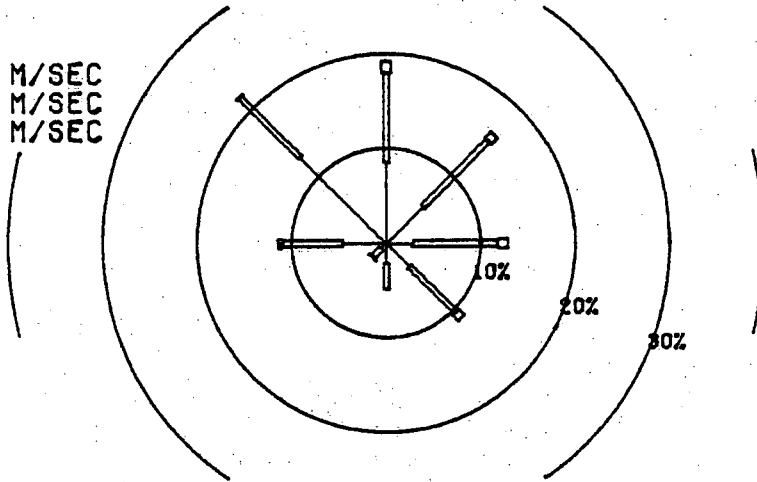

CURRENT  
 — 0-5 CM/SEC  
 = 5-15 CM/SEC  
 ≡ ≥ 15 CM/SEC

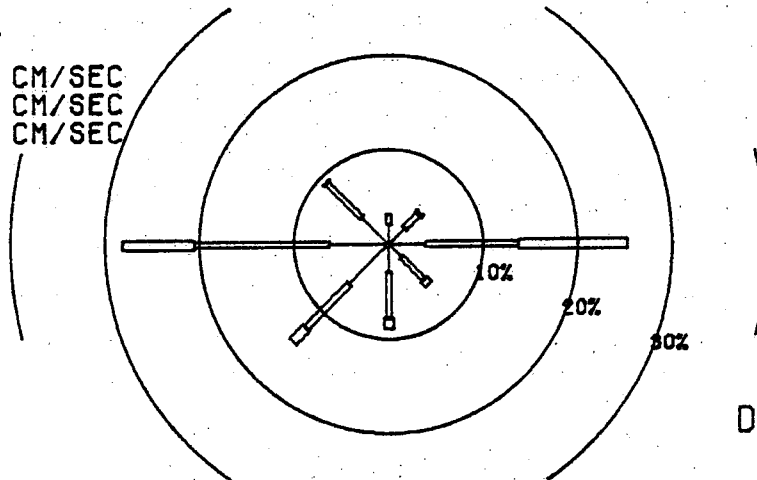

DEPTH: 9 M

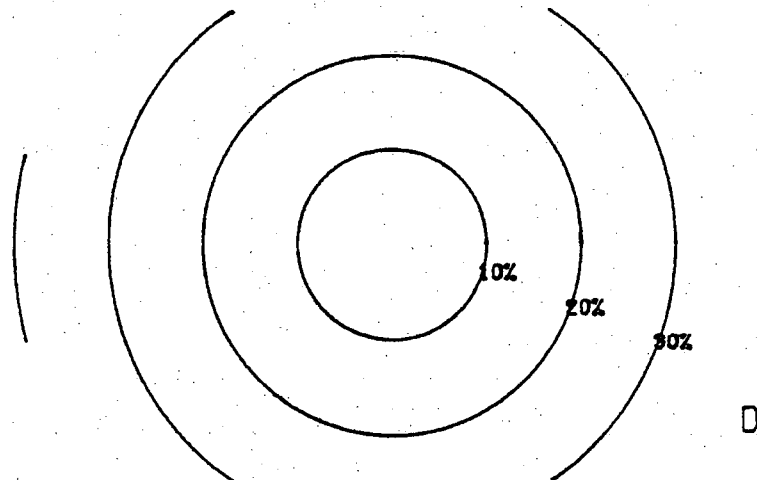

DEPTH: M

\* DIRECTION TOWARDS

MOORING: 23

DATE: SEPT 1973

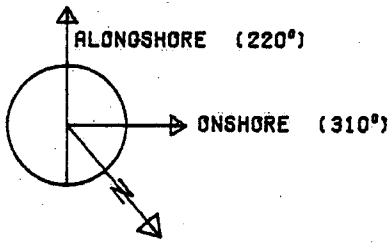

WINDSPEED<sup>2</sup>

0 40 M<sup>2</sup>/SEC<sup>2</sup>

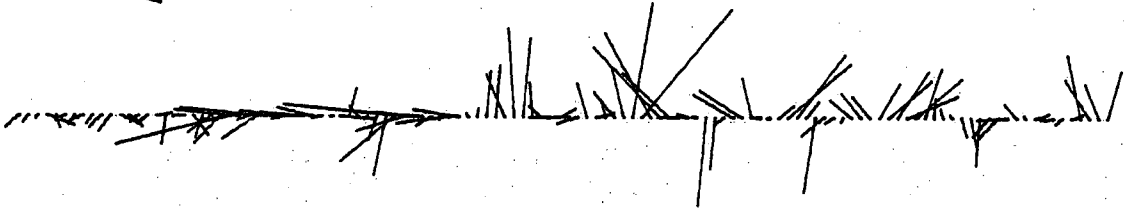

FILTERED CURRENT  
(0.0 TO 0.05 CPH)

DEPTH: 9 M

0 10 CM/SEC

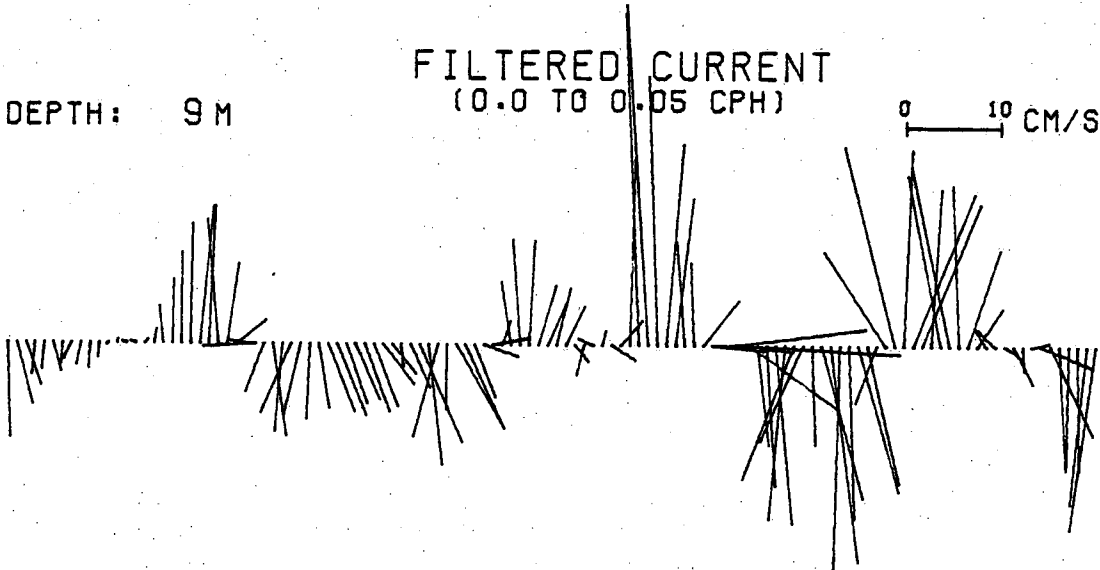

DEPTH: M

1 2 3 4 5 6 7 8 9 10 11 12 13 14 15 16 17 18 19 20 21 22 23 24 25 26 27 28 29 30 31

MOORING: 25      DATE: SEPT 1973  
 MONTHLY SUMMARY: WIND AND CURRENT\*

WIND  
 — 0-3 M/SEC  
 = 3-7 M/SEC  
 ≡ ≥ 7 M/SEC

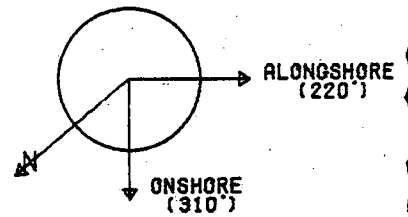
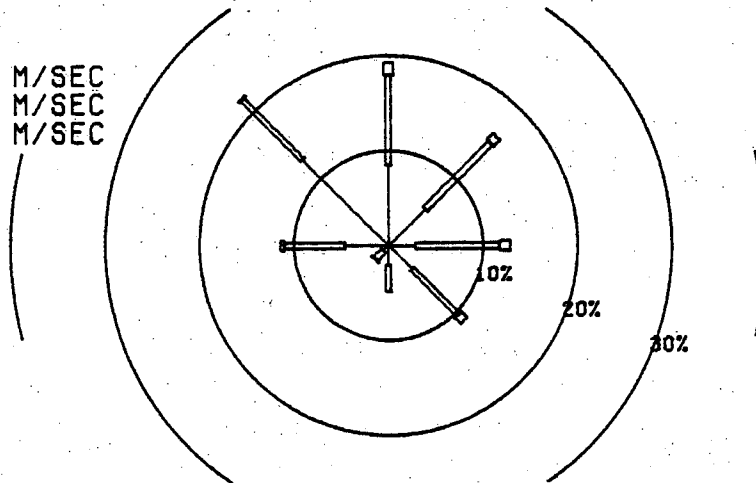

CURRENT  
 — 0-5 CM/SEC  
 = 5-15 CM/SEC  
 ≡ ≥ 15 CM/SEC

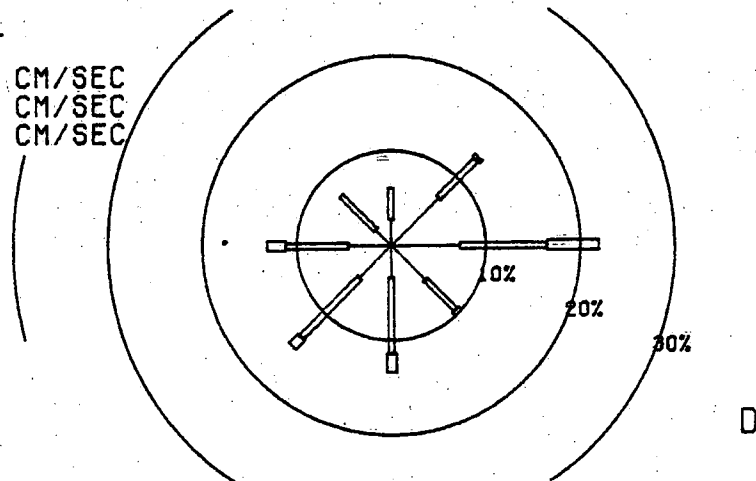

DEPTH: 9 M

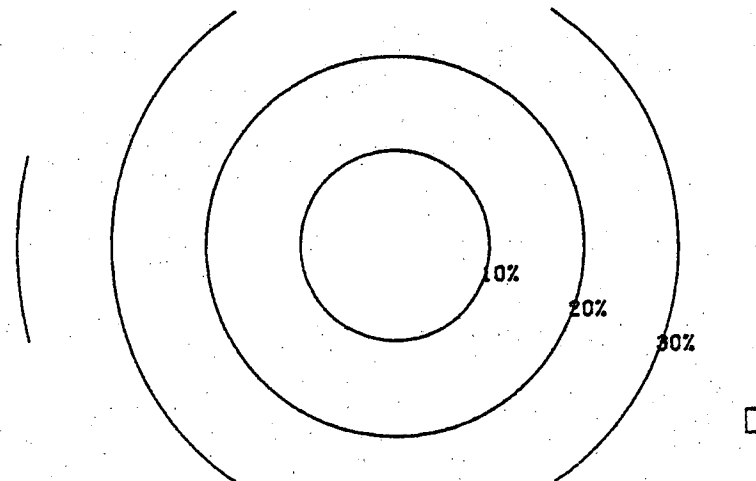

DEPTH: M

\* DIRECTION TOWARDS

MOORING : 25

DATE : SEPT 1973

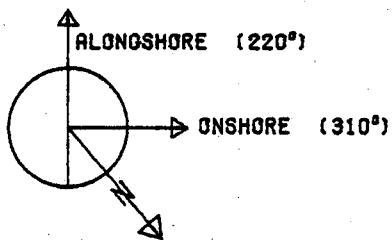

WINDSPEED<sup>2</sup>

0 40 M<sup>2</sup>/SEC<sup>2</sup>

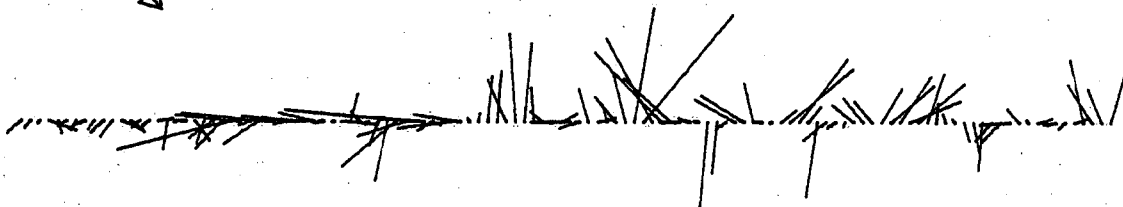

FILTERED CURRENT  
(0.0 TO 0.05 CPH)

DEPTH: 9 M

0 10 CM/SEC

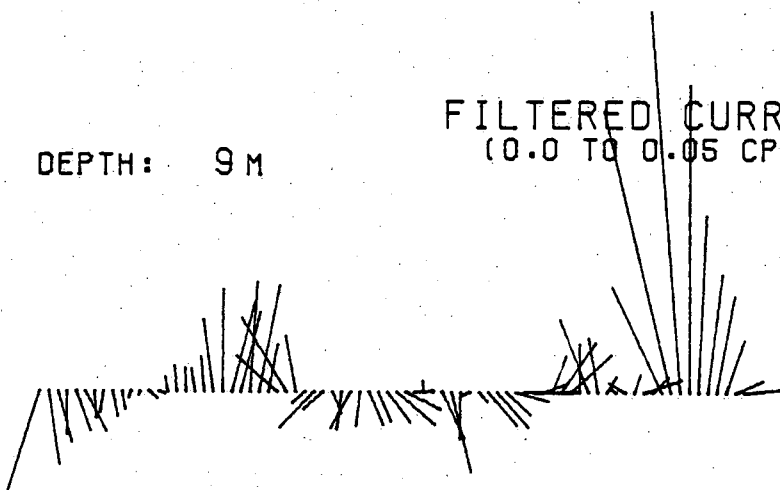

DEPTH: M

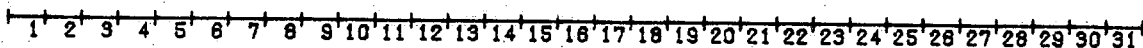

MOORING: 27      DATE: SEPT 1973  
 MONTHLY SUMMARY: WIND AND CURRENT\*

WIND  
 — 0-3 M/SEC  
 = 3-7 M/SEC  
 ≡ ≥ 7 M/SEC

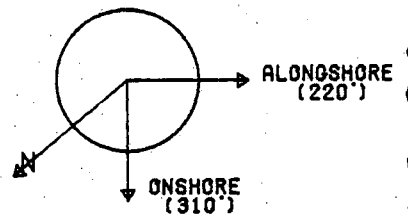
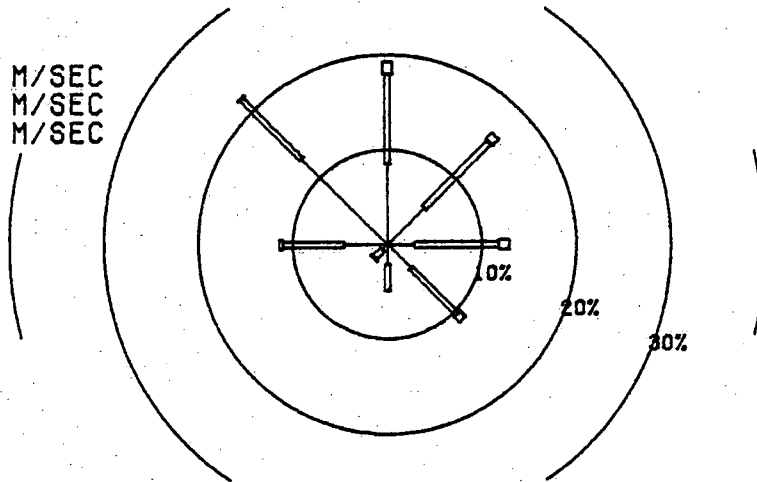

CURRENT  
 — 0-5 CM/SEC  
 = 5-15 CM/SEC  
 ≡ ≥ 15 CM/SEC

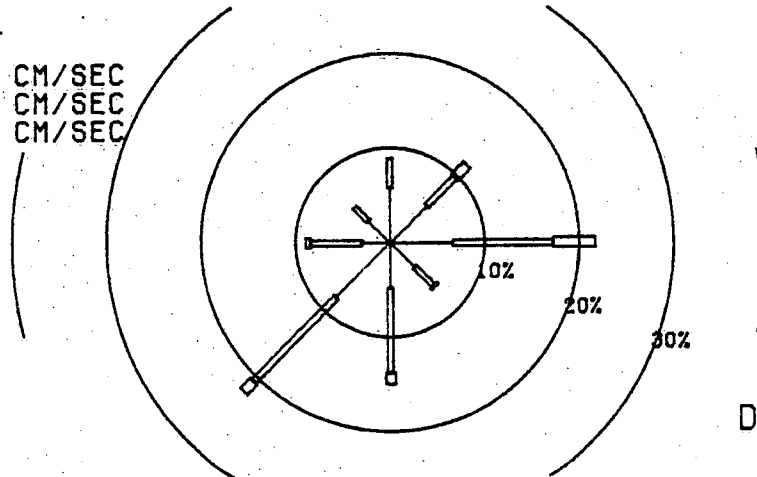

DEPTH: 9 M

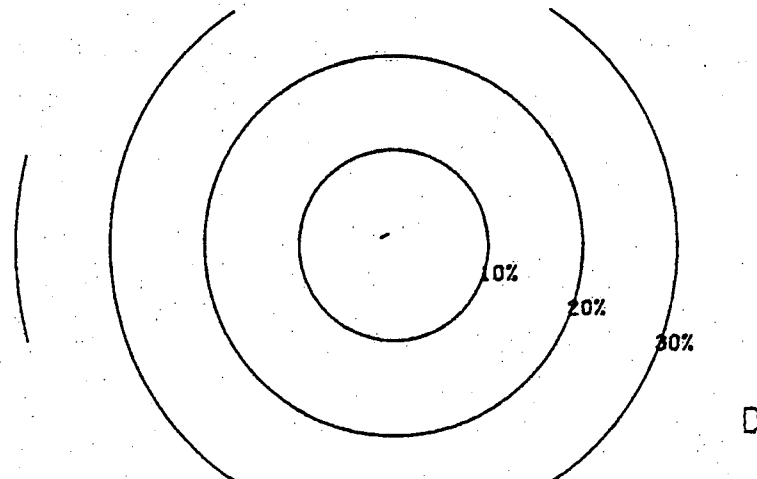

DEPTH: M

\* DIRECTION TOWARDS

MOORING : 27

DATE : SEPT 1973

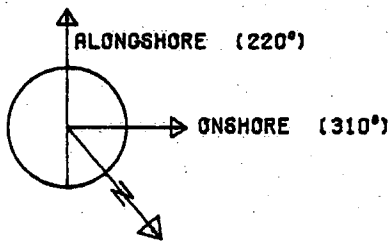

WINDSPEED<sup>2</sup>

0 40 M<sup>2</sup>/SEC<sup>2</sup>

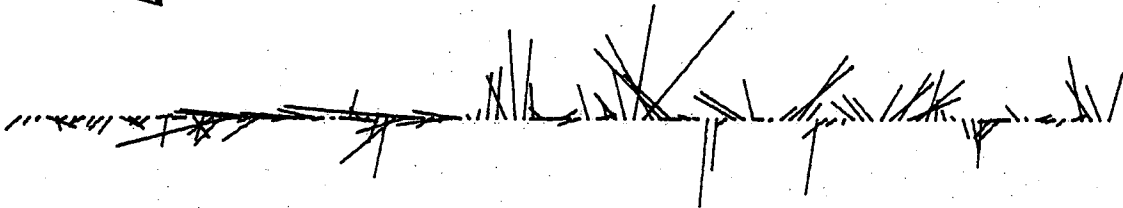

FILTERED CURRENT  
(0.0 TO 0.05 CPH)

DEPTH: 9 M

0 10 CM/SEC

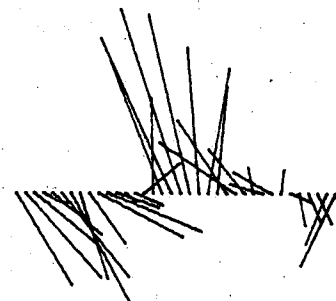
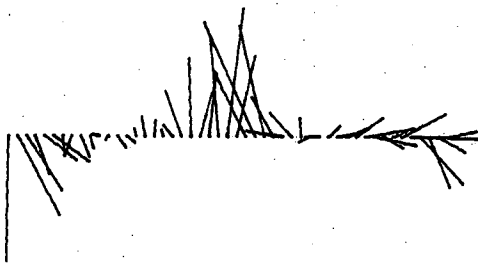

DEPTH: M

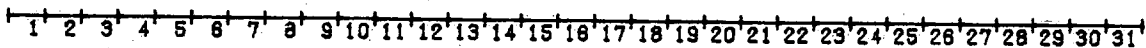



MOORING: 28      DATE: SEPT 1973  
 MONTHLY SUMMARY: WIND AND CURRENT\*

WIND  
 — 0-3 M/SEC  
 = 3-7 M/SEC  
 ≡ ≥ 7 M/SEC

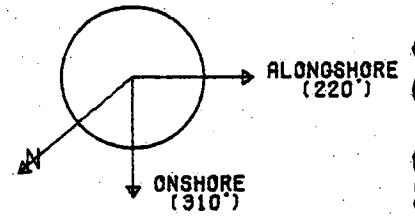
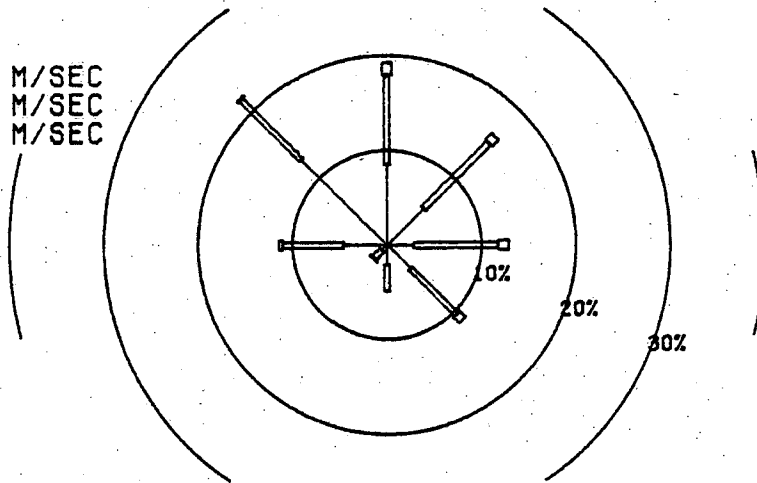

CURRENT  
 — 0-5 CM/SEC  
 = 5-15 CM/SEC  
 ≡ ≥ 15 CM/SEC

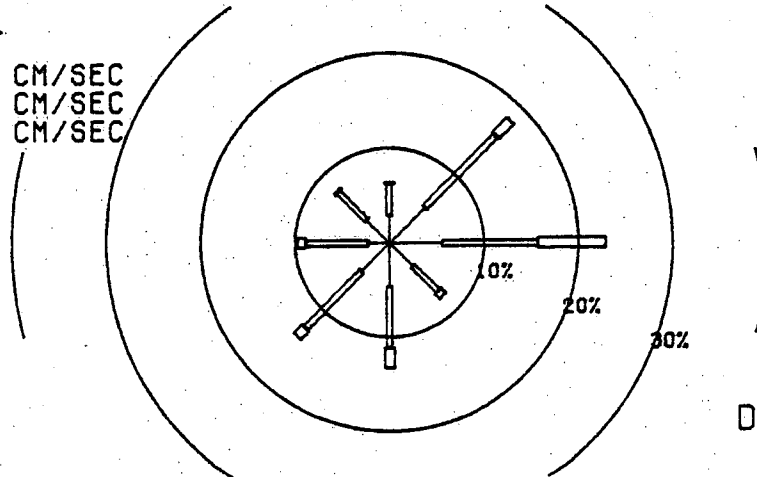

DEPTH: 8 M

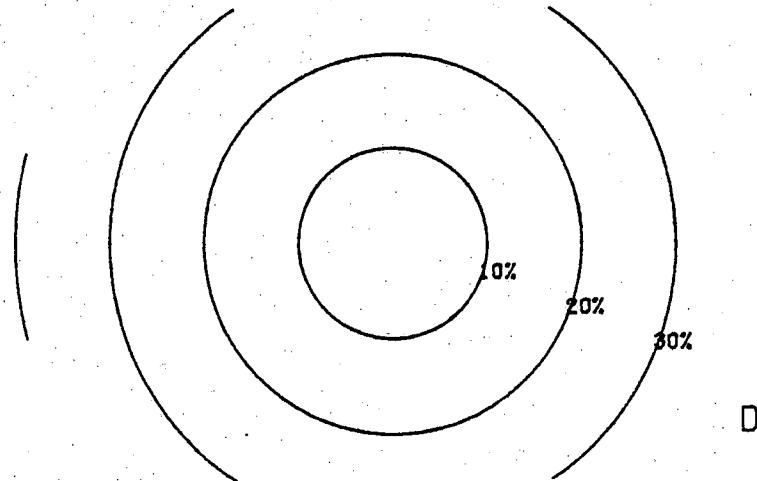

DEPTH: M

\* DIRECTION TOWARDS

MOORING : 28

DATE : SEPT 1973

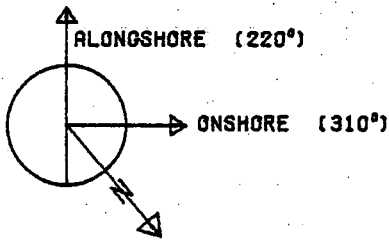

WINDSPEED<sup>2</sup>

0 40 M<sup>2</sup>/SEC<sup>2</sup>

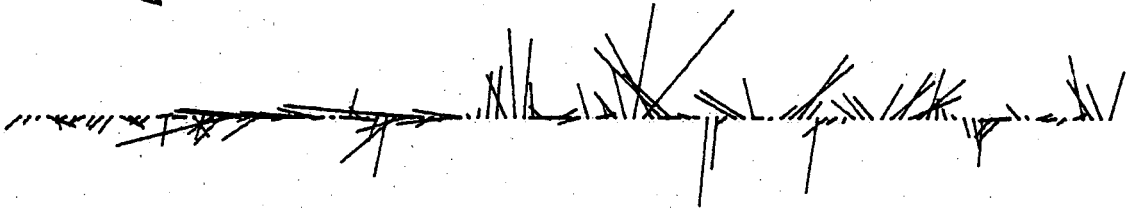

FILTERED CURRENT  
(0.0 TO 0.05 CPH)

DEPTH: 8 M

0 10 CM/SEC



DEPTH: M

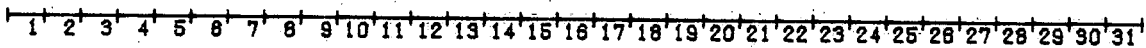

# METEOROLOGICAL DATA

MOORING: BURLINGTON DATE: OCT 1973

## FILTERED WIND (0.0 TO 0.05 CPH)

0 10 M/SEC

N ↑



## FILTERED WIND (0.0 TO 0.2 CPH) \*

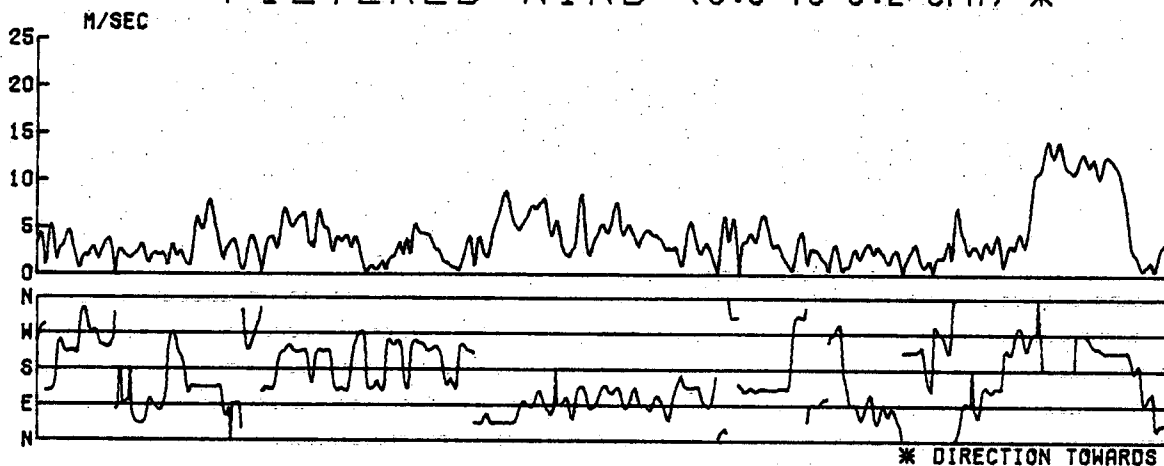

## TEMPERATURE °C

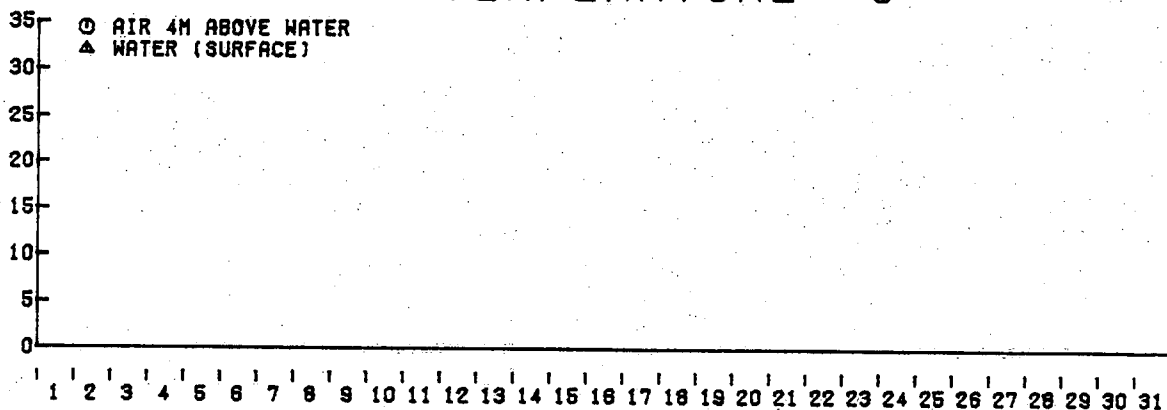

### DAILY MAXIMUM AND MINIMUM AIR TEMPERATURE

DAY	TMAX	TMIN	DAY	TMAX	TMIN	DAY	TMAX	TMIN	DAY	TMAX	TMIN
1			9			17			25		
2			10			18			26		
3			11			19			27		
4			12			20			28		
5			13			21			29		
6			14			22			30		
7			15			23			31		
8			16			24					

MOORING: 22      DATE: OCT 1973  
 MONTHLY SUMMARY: WIND AND CURRENT\*

WIND  
 — 0-3 M/SEC  
 = 3-7 M/SEC  
 = 7 M/SEC

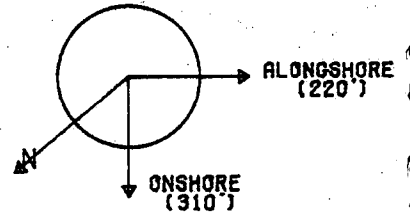
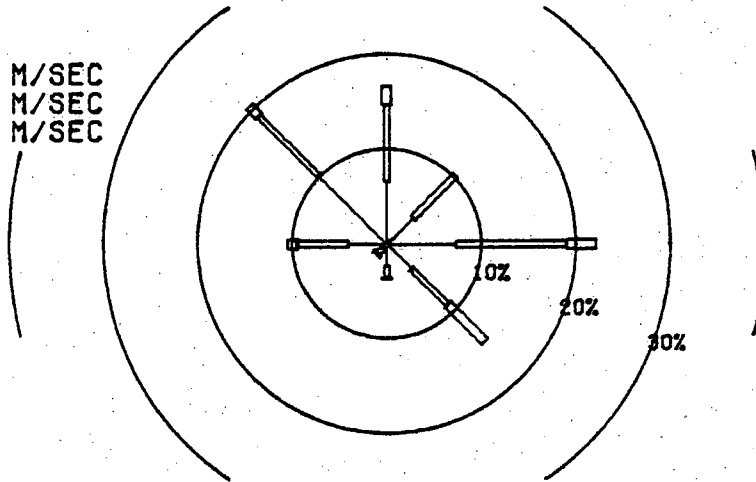

CURRENT  
 — 0-5 CM/SEC  
 = 5-15 CM/SEC  
 = 15 CM/SEC

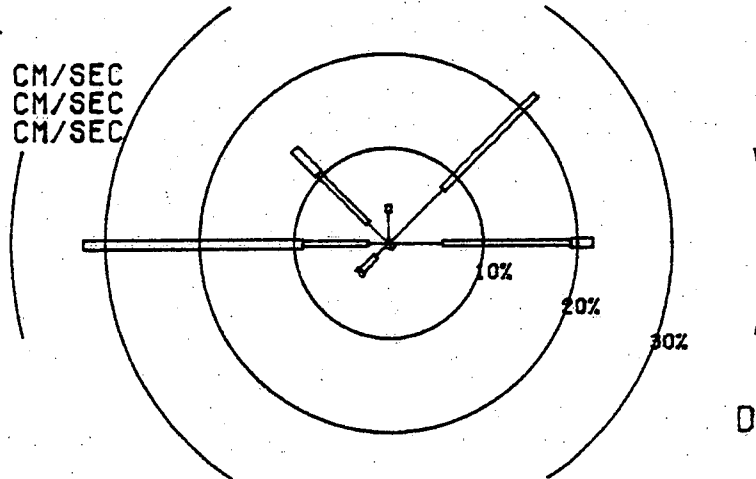

DEPTH: 9 M

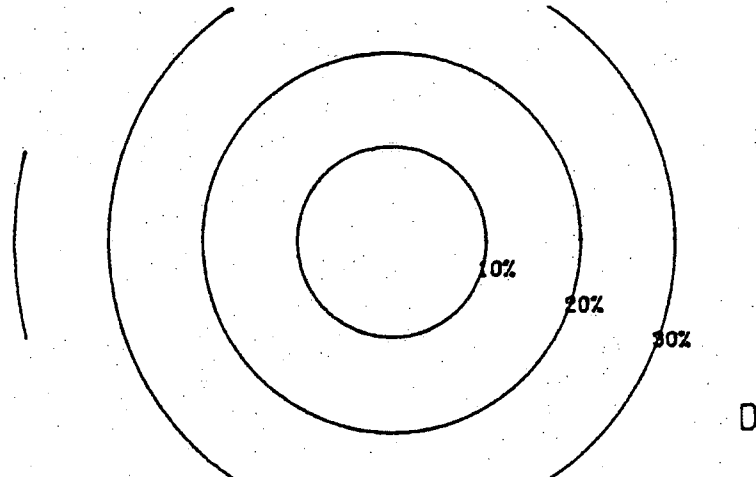

DEPTH: M

\* DIRECTION TOWARDS

MOORING : 22

DATE : OCT 1973

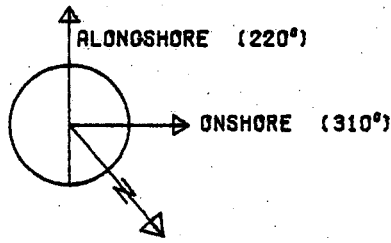

WINDSPEED<sup>2</sup>

0 40 M<sup>2</sup>/SEC<sup>2</sup>

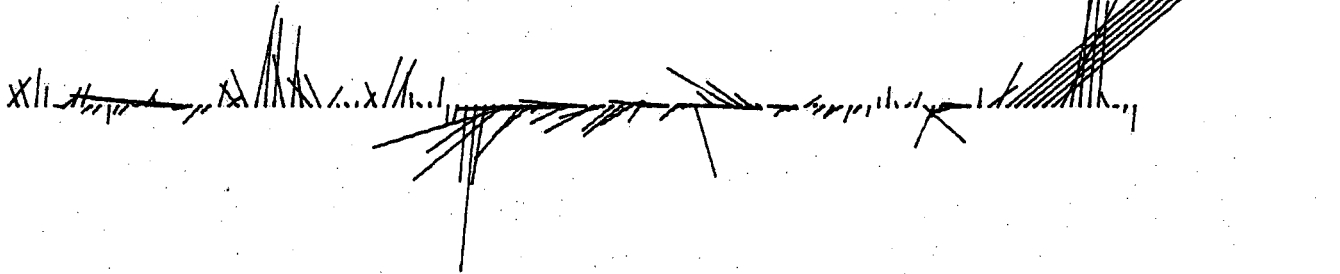

FILTERED CURRENT  
(0.0 TO 0.05 CPH)

DEPTH: 9 M

0 10 CM/SEC

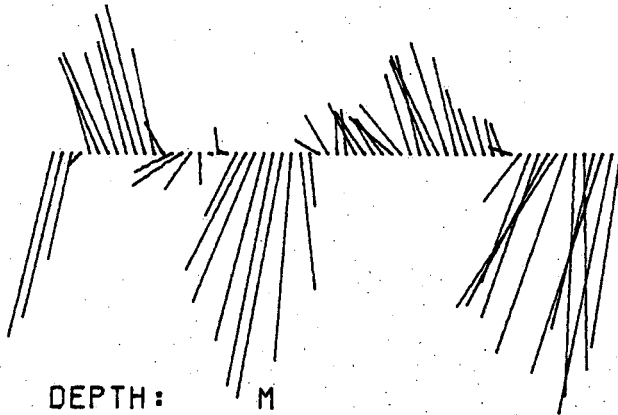

DEPTH: M

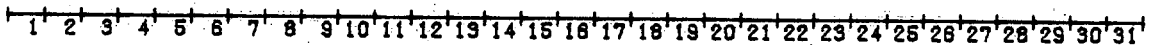

MOORING: 23      DATE: OCT 1973  
 MONTHLY SUMMARY: WIND AND CURRENT\*

WIND  
 — 0-3 M/SEC  
 = 3-7 M/SEC  
 ≡ ≥ 7 M/SEC

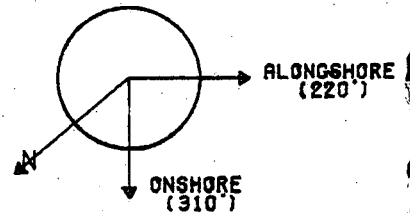
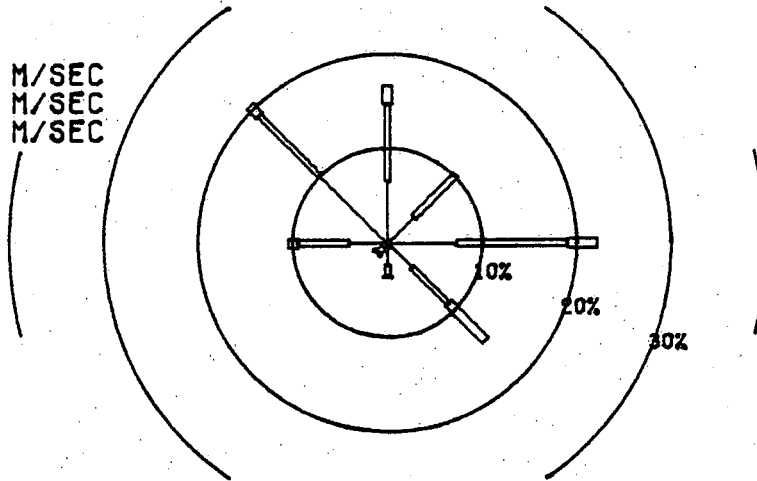

CURRENT  
 — 0-5 CM/SEC  
 = 5-15 CM/SEC  
 ≡ ≥ 15 CM/SEC

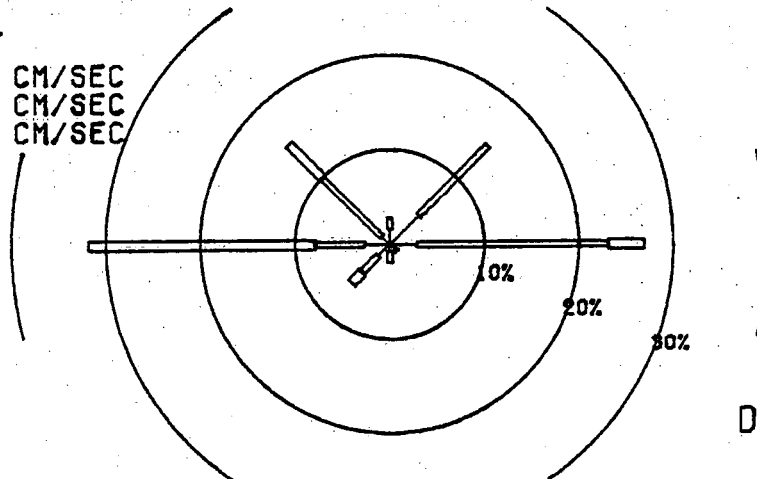

DEPTH: 9 M

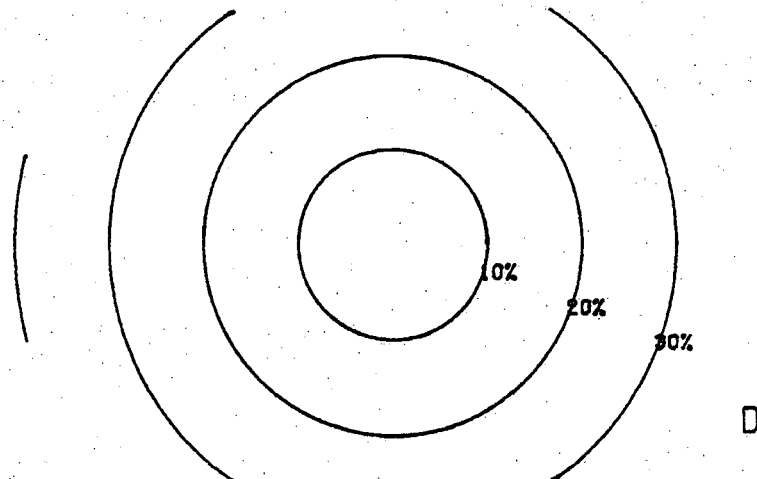

DEPTH: M

\* DIRECTION TOWARDS

MOORING : 23

DATE : OCT 1973

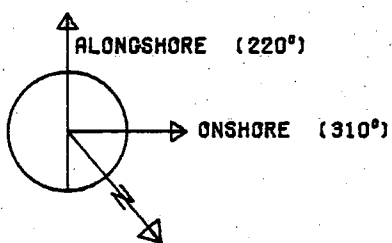

WINDSPEED<sup>2</sup>

0 40 M<sup>2</sup>/SEC<sup>2</sup>

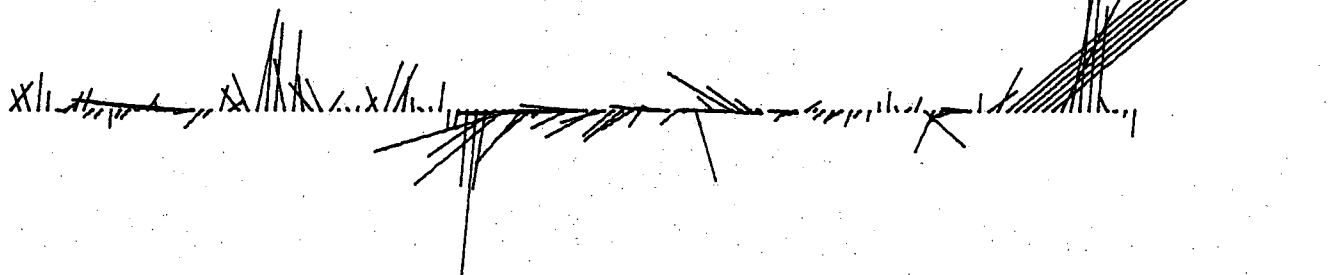

FILTERED CURRENT  
(0.0 TO 0.05 CPH)

DEPTH: 9 M

0 10 CM/SEC

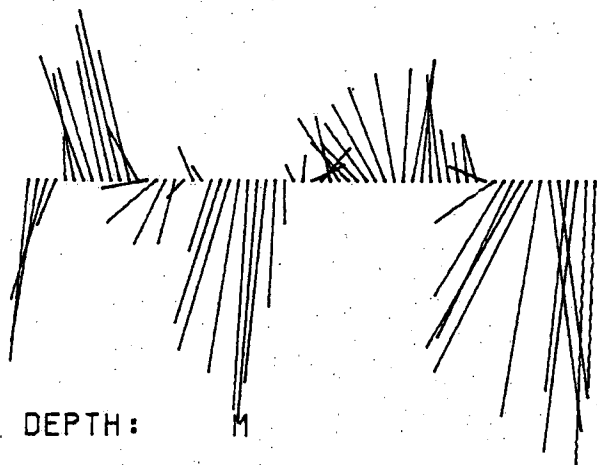

1 2 3 4 5 6 7 8 9 10 11 12 13 14 15 16 17 18 19 20 21 22 23 24 25 26 27 28 29 30 31

MOORING: 27      DATE: OCT 1973  
 MONTHLY SUMMARY: WIND AND CURRENT\*

WIND  
 — 0-3 M/SEC  
 = 3-7 M/SEC  
 ≡ ≥ 7 M/SEC

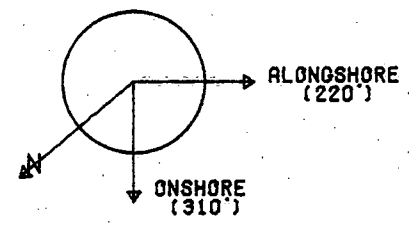
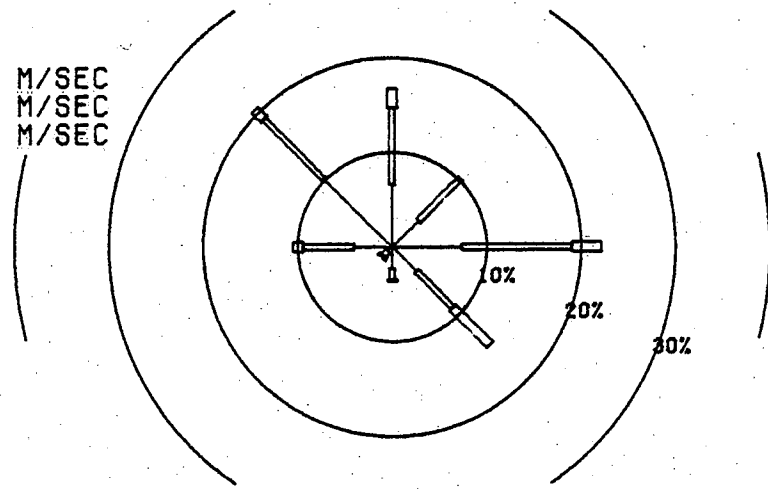

CURRENT  
 — 0-5 CM/SEC  
 = 5-15 CM/SEC  
 ≡ ≥ 15 CM/SEC

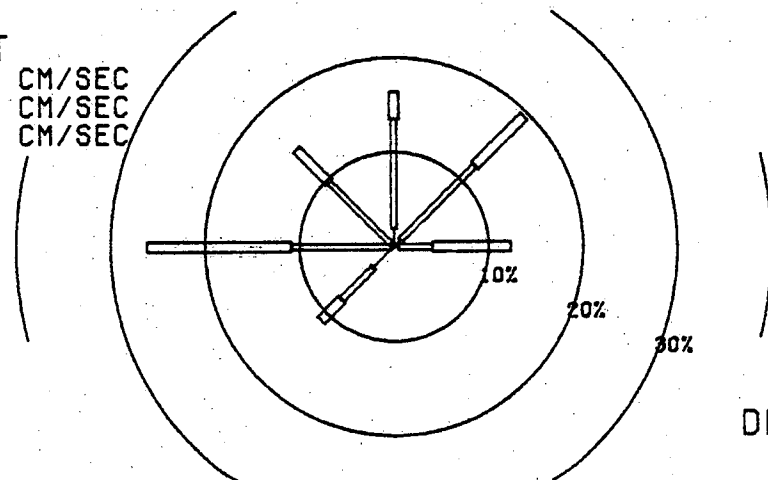

DEPTH: 9 M

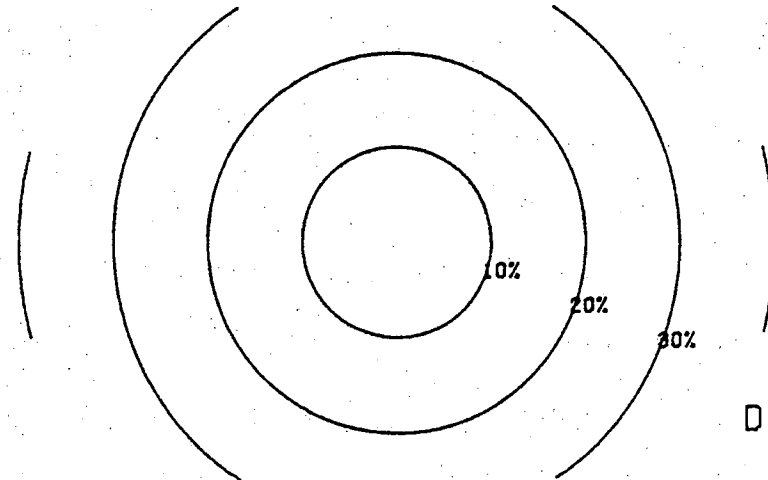

DEPTH: M

\* DIRECTION TOWARDS



MOORING : 27

DATE : OCT 1973

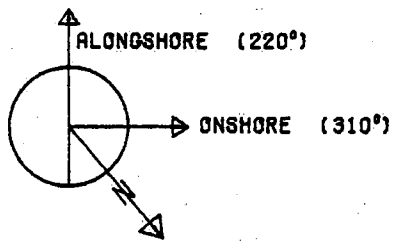

WINDSPEED<sup>2</sup>

0 40 M<sup>2</sup>/SEC<sup>2</sup>

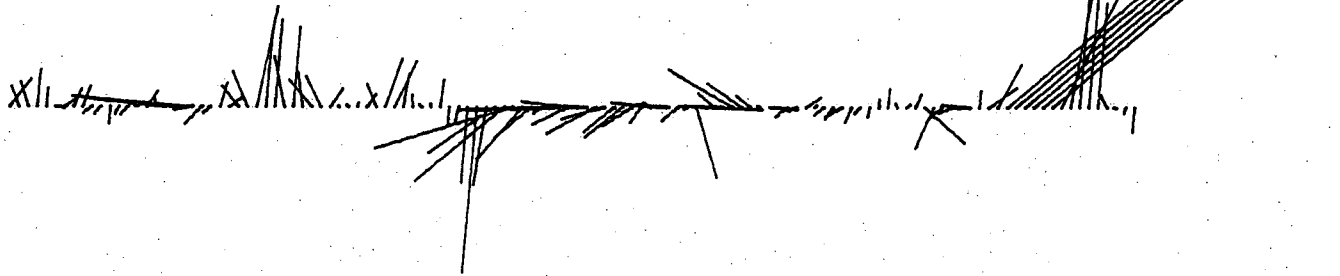

FILTERED CURRENT  
(0.0 TO 0.05 CPH)

DEPTH: 9 M

0 10 CM/SEC

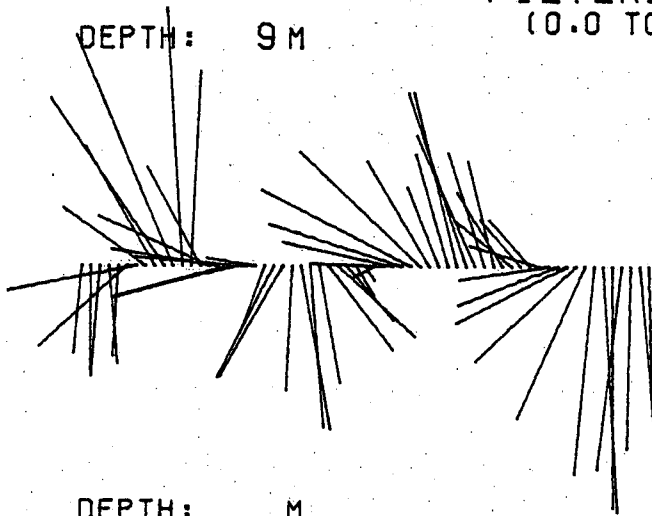

DEPTH: M

1' 2' 3' 4' 5' 6' 7' 8' 9' 10' 11' 12' 13' 14' 15' 16' 17' 18' 19' 20' 21' 22' 23' 24' 25' 26' 27' 28' 29' 30' 31'

MOORING: 28      DATE: OCT 1973  
 MONTHLY SUMMARY: WIND AND CURRENT\*

WIND  
 — 0-3 M/SEC  
 = 3-7 M/SEC  
 ≡ ≥ 7 M/SEC

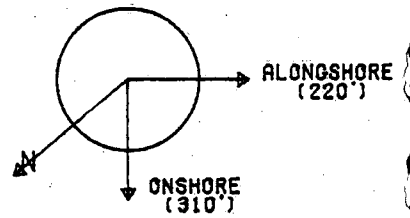
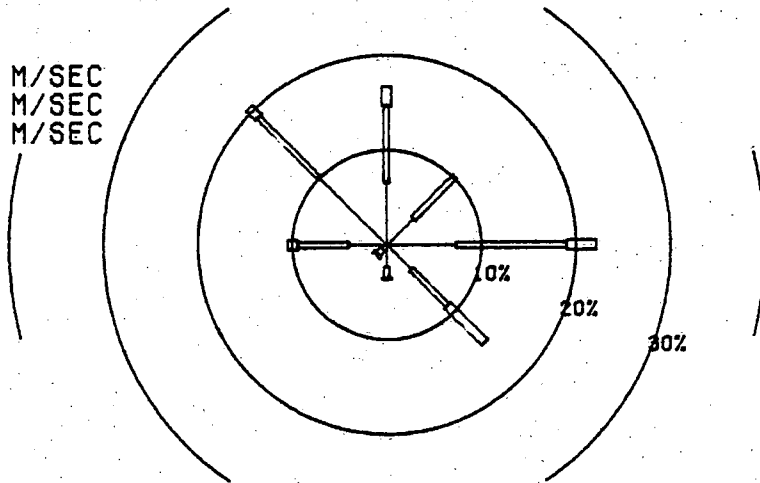

CURRENT  
 — 0-5 CM/SEC  
 = 5-15 CM/SEC  
 ≡ ≥ 15 CM/SEC

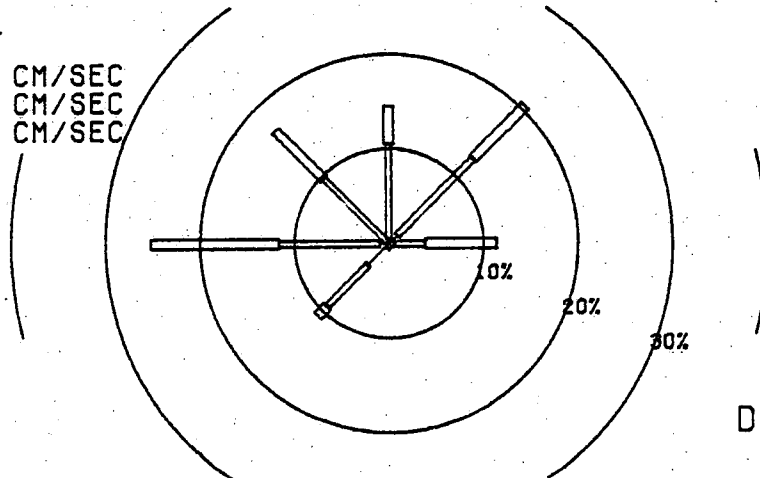

DEPTH: 8 M

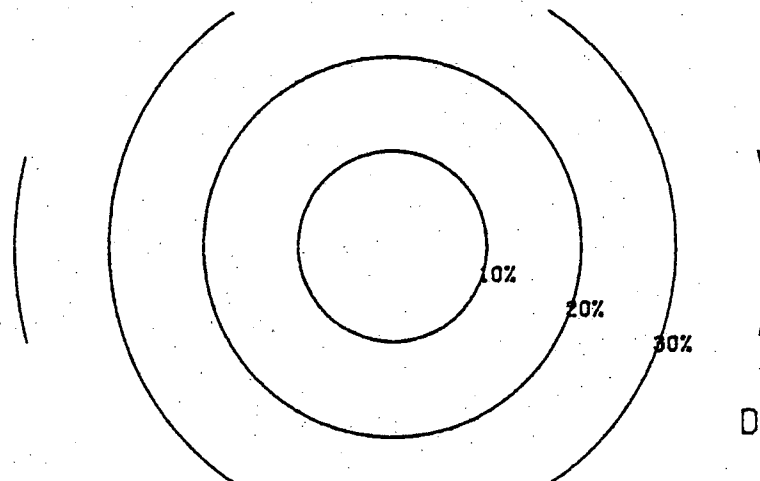

DEPTH: M

\* DIRECTION TOWARDS

MOORING: 28

DATE: OCT 1973

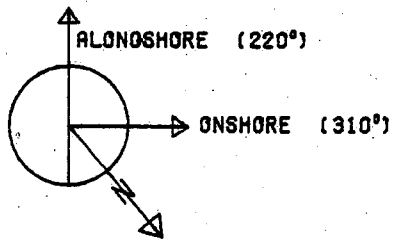

WINDSPEED<sup>2</sup>

0 40 M<sup>2</sup>/SEC<sup>2</sup>

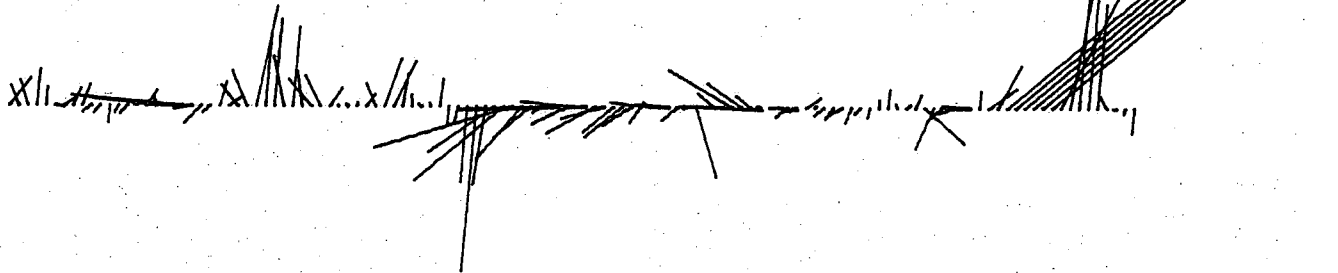

FILTERED CURRENT  
(0.0 TO 0.05 CPH)

DEPTH: 8 M

0 10 CM/SEC

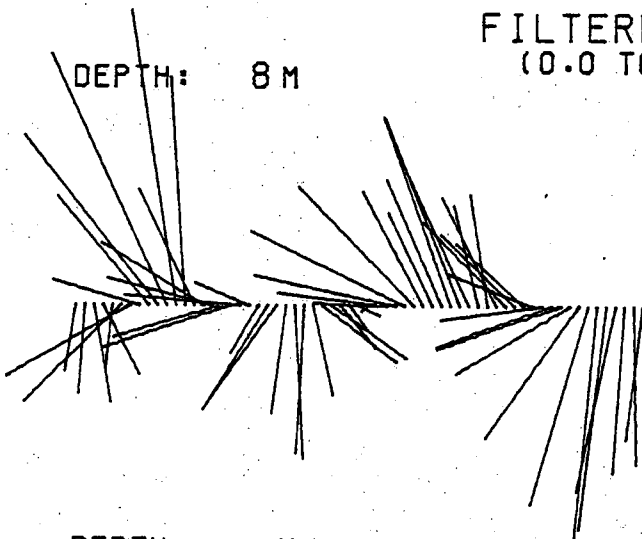

DEPTH: M

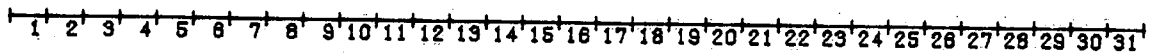

MOORING: 30      DATE: OCT 1973  
 MONTHLY SUMMARY: WIND AND CURRENT\*

WIND  
 — 0-3 M/SEC  
 = 3-7 M/SEC  
 ≡ ≥ 7 M/SEC

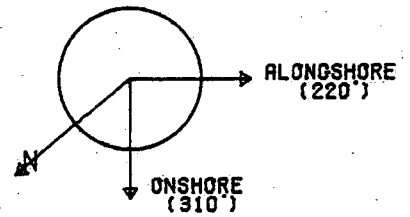
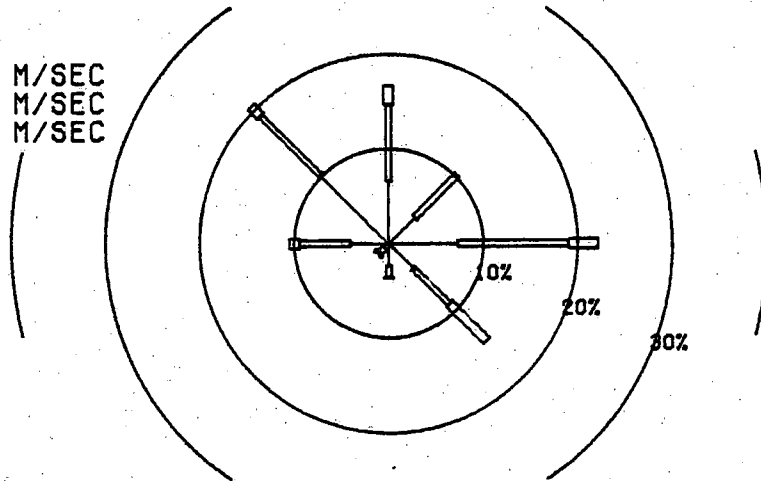

CURRENT  
 — 0-5 CM/SEC  
 = 5-15 CM/SEC  
 ≡ ≥ 15 CM/SEC

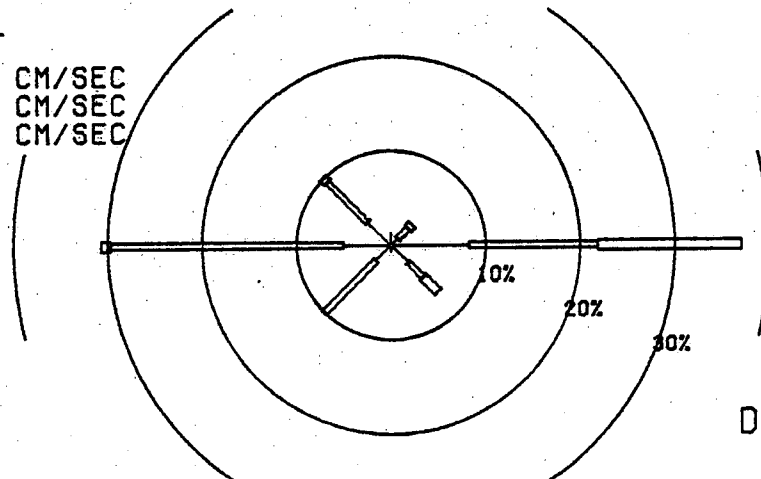

DEPTH: 10 M

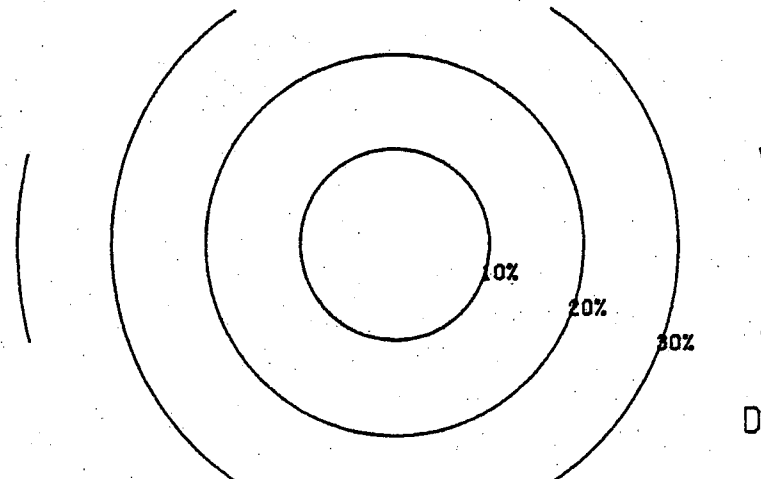

DEPTH: M

\* DIRECTION TOWARDS

MOORING: 30

DATE: OCT 1973

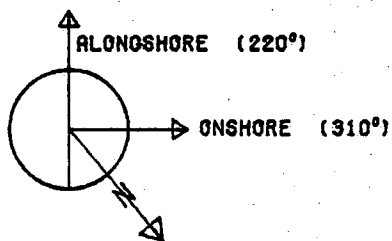

WINDSPEED<sup>2</sup>

0 40 M<sup>2</sup>/SEC<sup>2</sup>

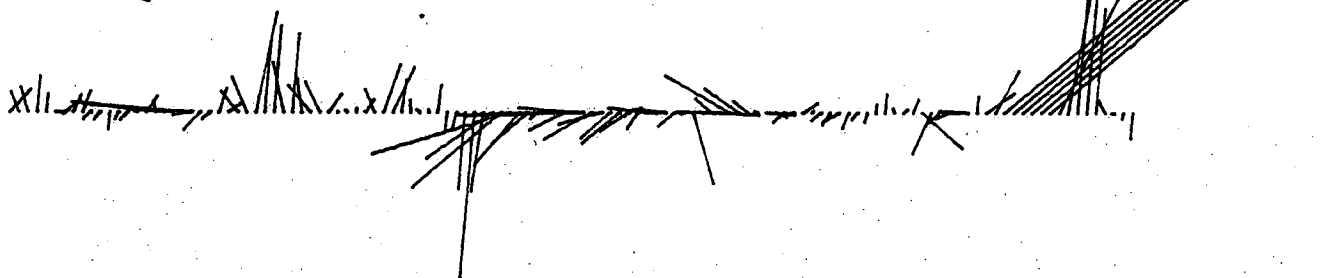

DEPTH: 10 M

FILTERED CURRENT  
(0.0 TO 0.05 CPH)

0 10 CM/SEC

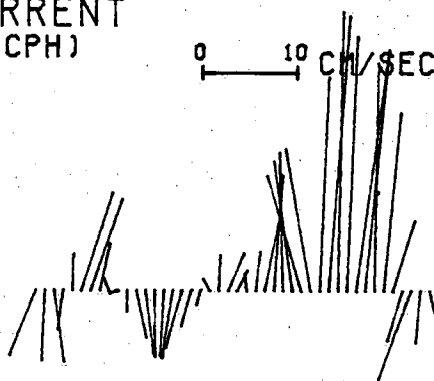

DEPTH: M

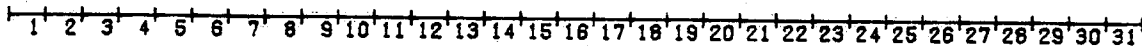

MOORING: 31      DATE: OCT 1973  
 MONTHLY SUMMARY: WIND AND CURRENT\*

WIND  
 — 0-3 M/SEC  
 = 3-7 M/SEC  
 ≡ ≥ 7 M/SEC

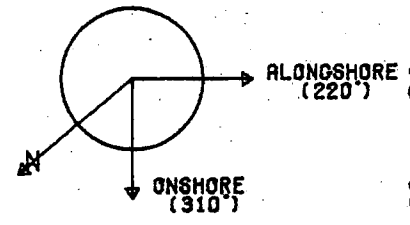
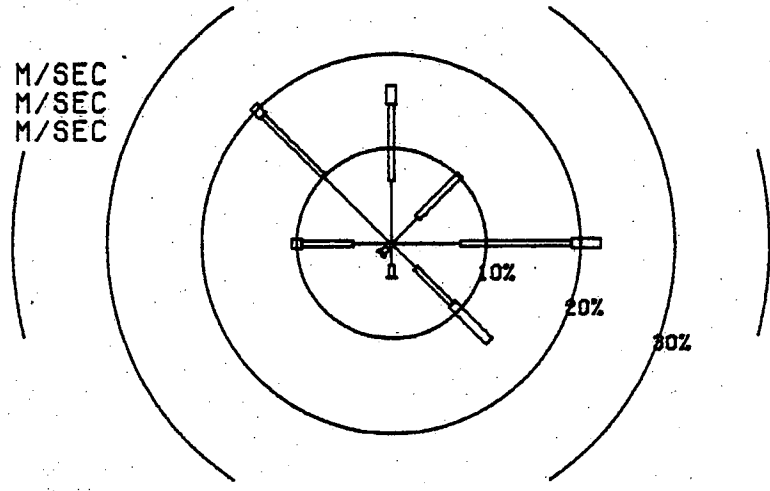

CURRENT  
 — 0-5 CM/SEC  
 = 5-15 CM/SEC  
 ≡ ≥ 15 CM/SEC

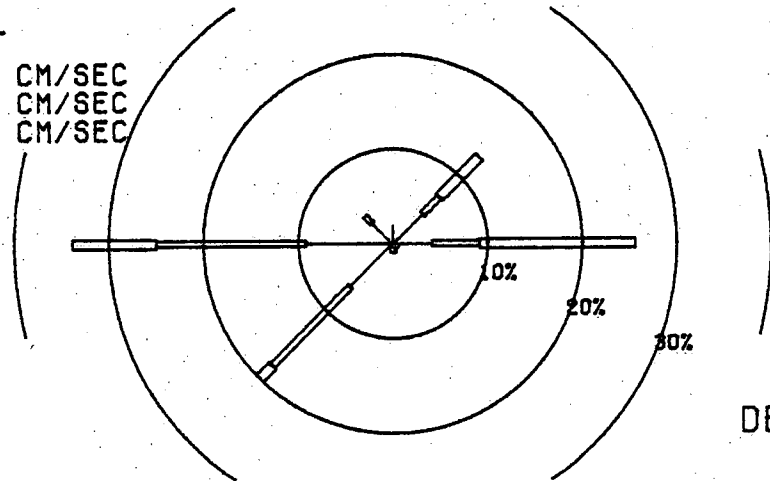

DEPTH: 10 M

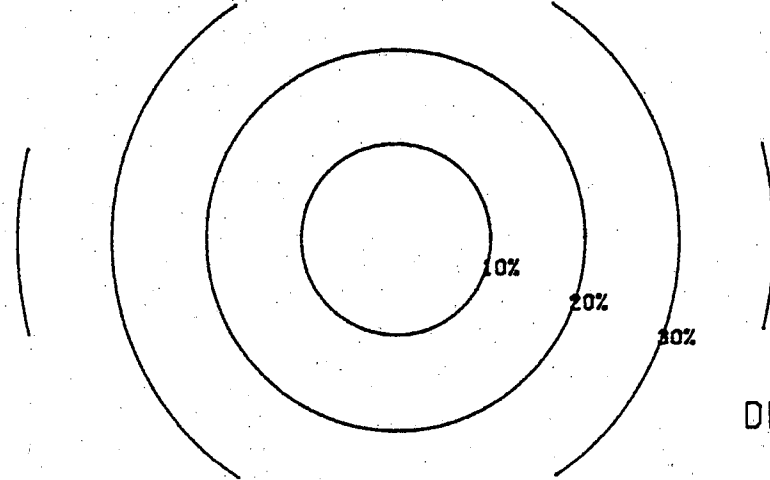

DEPTH: M

\* DIRECTION TOWARDS

MOORING: 31

DATE: OCT 1973

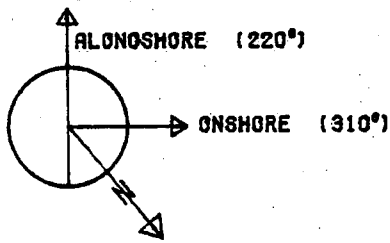

WINDSPEED<sup>2</sup>

0 40 M<sup>2</sup>/SEC<sup>2</sup>

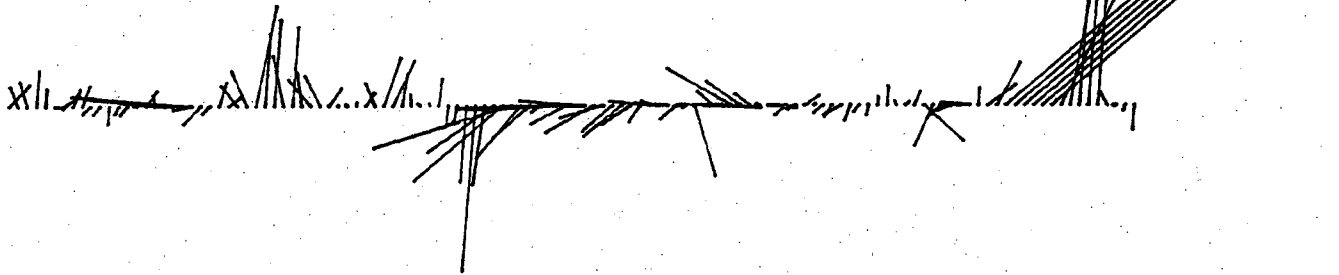

DEPTH: 10 M

FILTERED CURRENT  
(0.0 TO 0.05 CPH)

0 10 CM/SEC

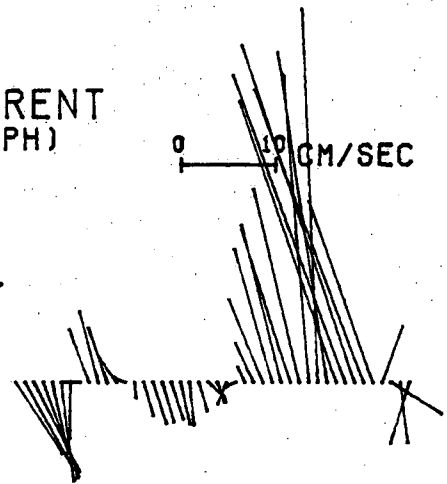

DEPTH: M

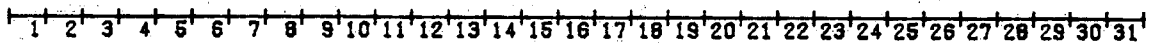

MOORING: 32      DATE: OCT 1973  
 MONTHLY SUMMARY: WIND AND CURRENT\*

WIND  
 — 0-3 M/SEC  
 = 3-7 M/SEC  
 ≡ ≥ 7 M/SEC

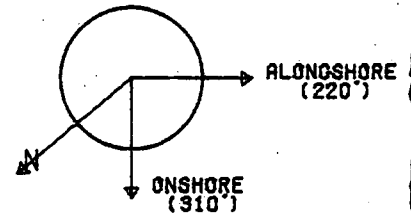
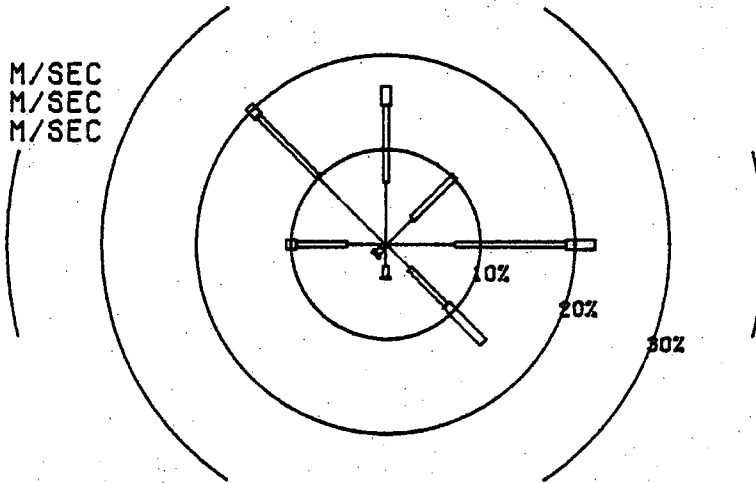

CURRENT  
 — 0-5 CM/SEC  
 = 5-15 CM/SEC  
 ≡ ≥ 15 CM/SEC

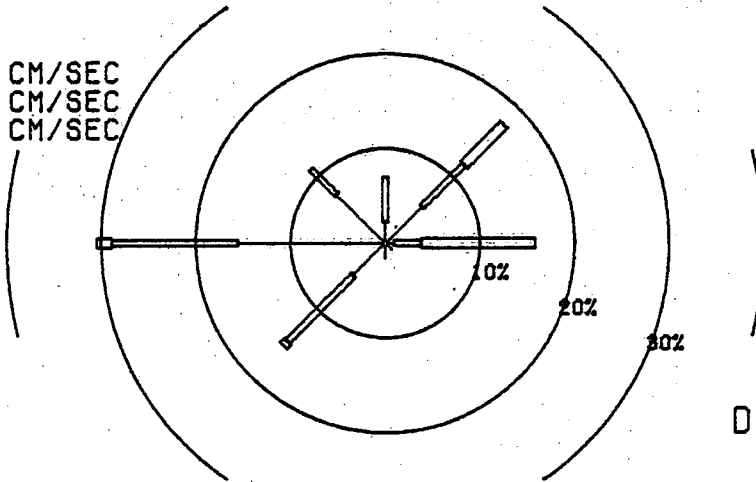

DEPTH: 10 M

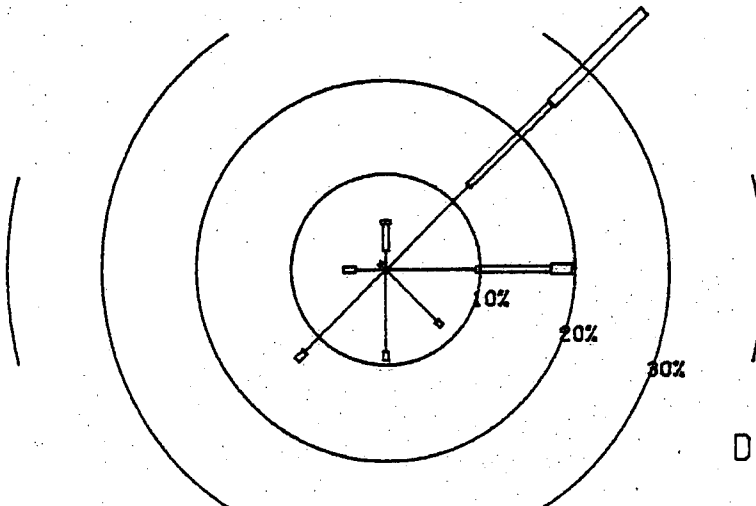

DEPTH: 51 M

\* DIRECTION TOWARDS



MOORING : 32

DATE : OCT 1973

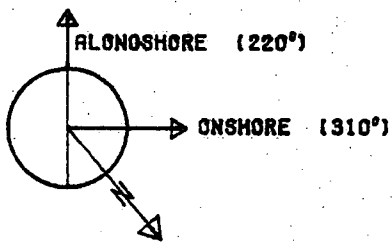

WINDSPEED<sup>2</sup>

0 40 M<sup>2</sup>/SEC<sup>2</sup>

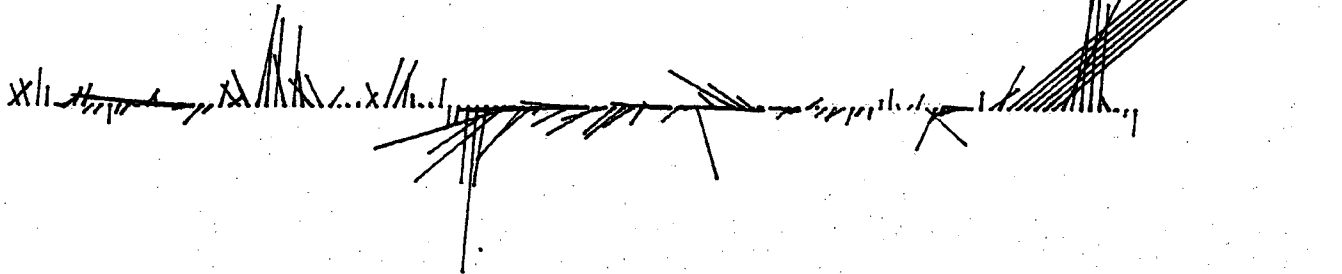

DEPTH: 10 M

FILTERED CURRENT  
(0.0 TO 0.05 CPH)

0 10 CM/SEC

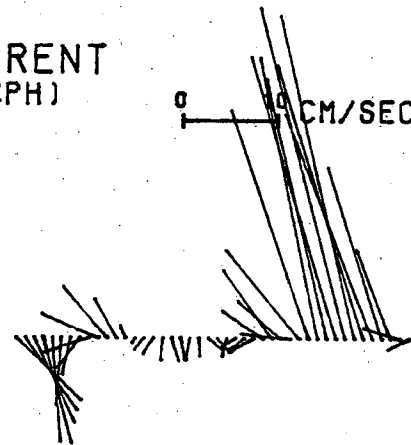

DEPTH: 51 M

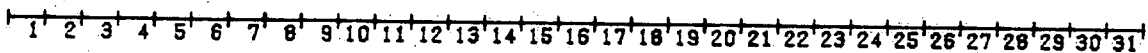

MOORING: 33

DATE: OCT 1973

MONTHLY SUMMARY: WIND AND CURRENT\*

WIND  
— 0-3 M/SEC  
= 3-7 M/SEC  
≡ ≥ 7 M/SEC

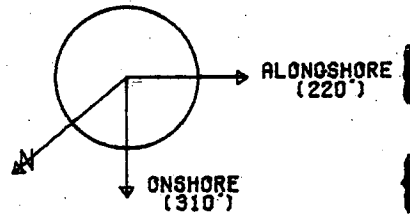
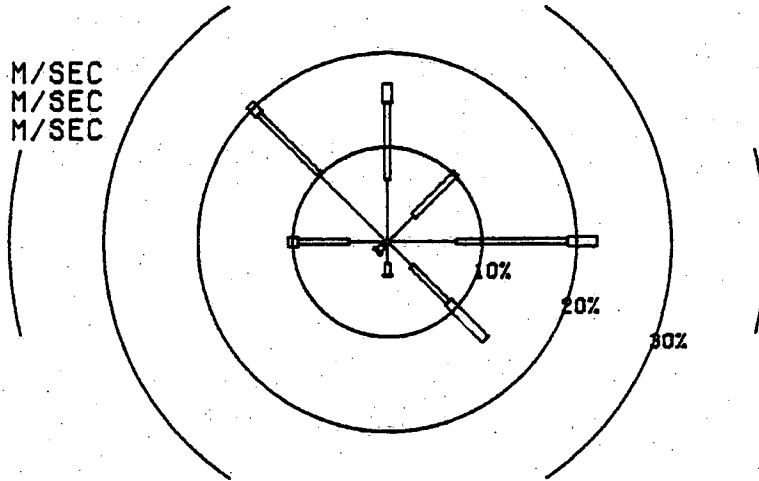

CURRENT  
— 0-5 CM/SEC  
= 5-15 CM/SEC  
≡ ≥ 15 CM/SEC

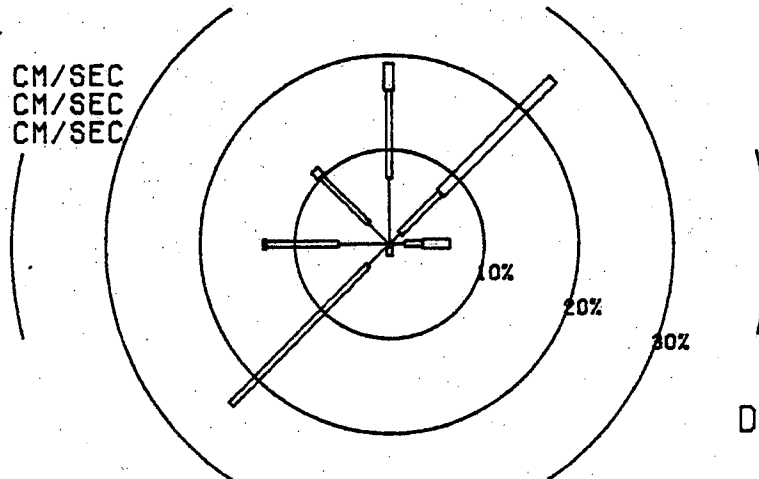

DEPTH: 10 M

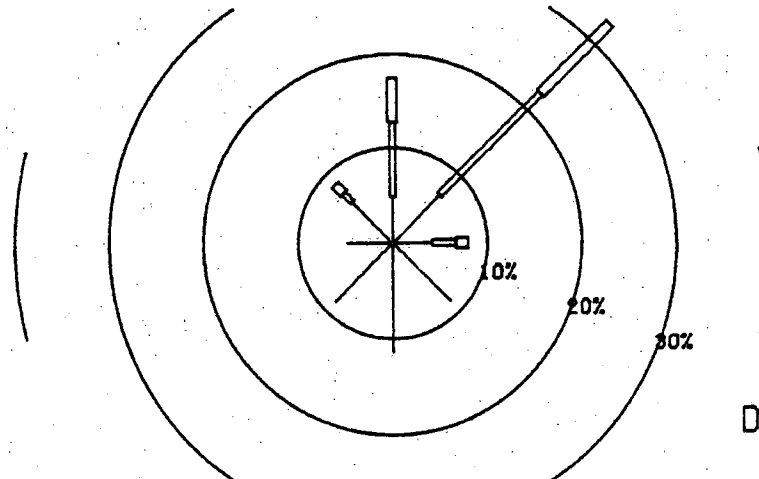

DEPTH: 61 M

\* DIRECTION TOWARDS

MOORING: 33

DATE: OCT 1973

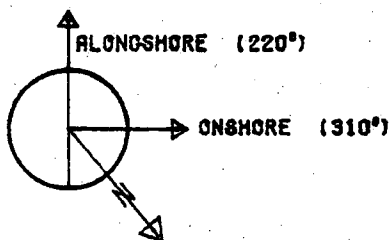

WINDSPEED<sup>2</sup>

0 40 M<sup>2</sup>/SEC<sup>2</sup>

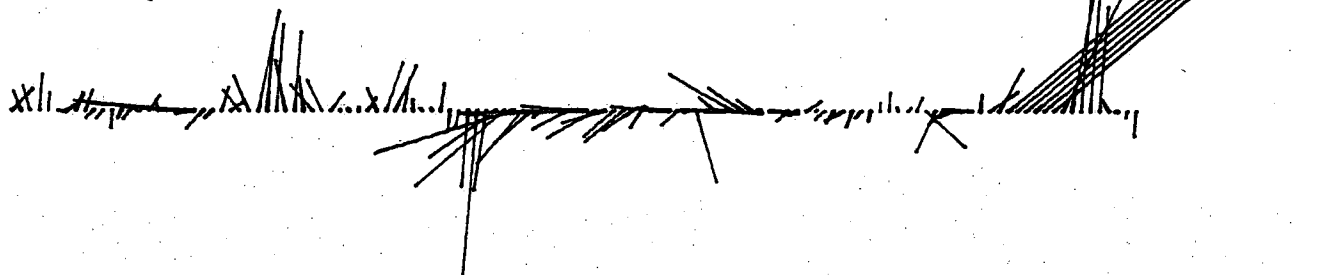

DEPTH: 10 M

FILTERED CURRENT  
(0.0 TO 0.05 CPH)

0 10 CM/SEC

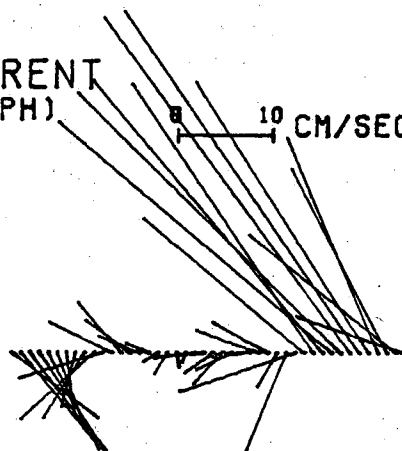

DEPTH: 61 M

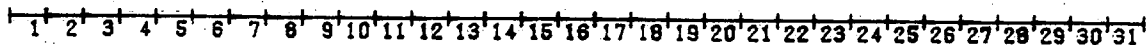
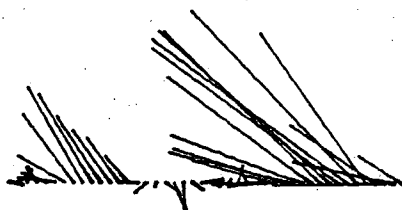

MOORING: 34      DATE: OCT 1973  
 MONTHLY SUMMARY: WIND AND CURRENT\*

WIND  
 — 0-3 M/SEC  
 = 3-7 M/SEC  
 ≡ ≥ 7 M/SEC

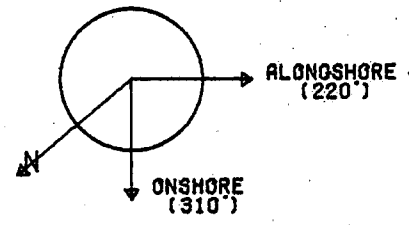
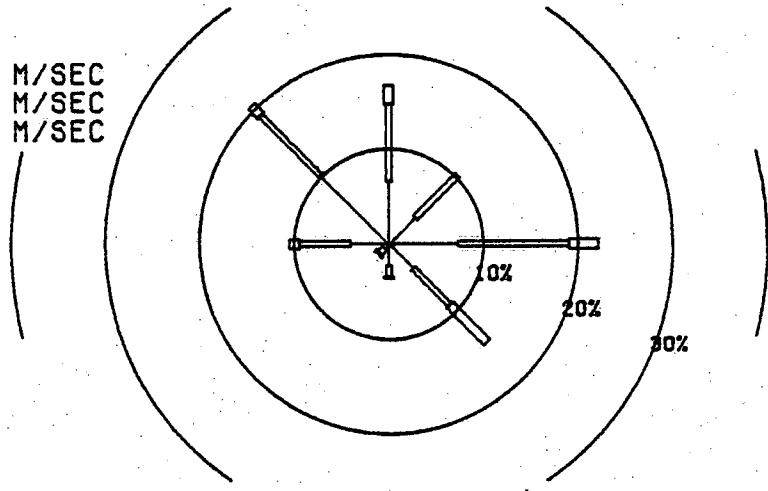

CURRENT  
 — 0-5 CM/SEC  
 = 5-15 CM/SEC  
 ≡ ≥ 15 CM/SEC

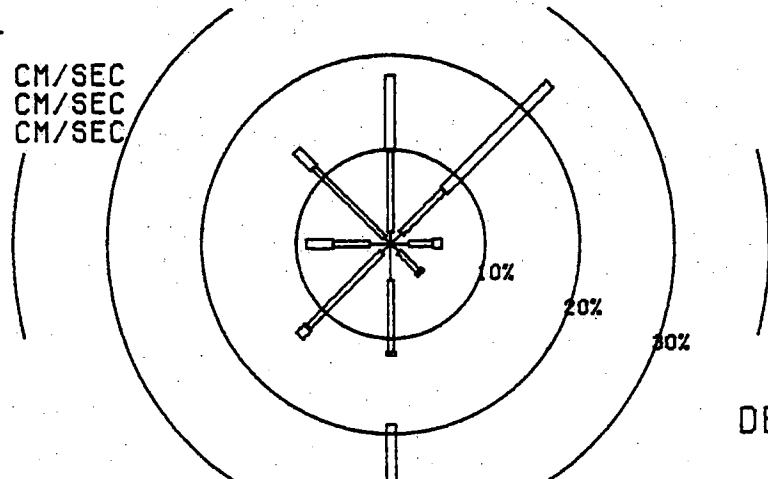

DEPTH: 10 M

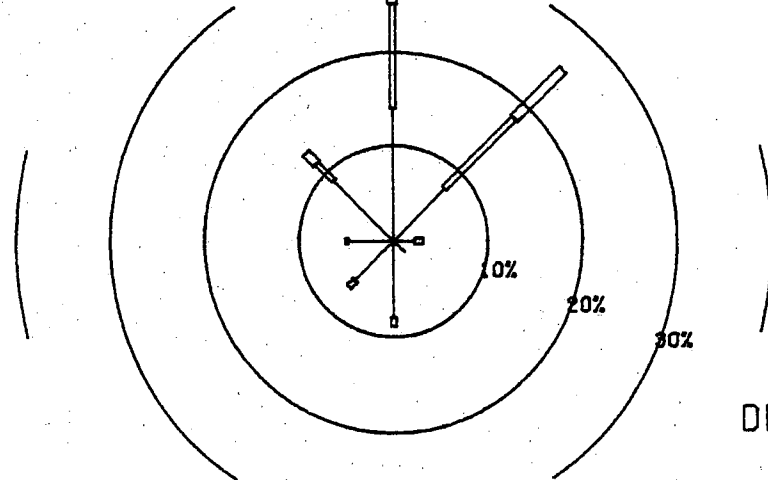

DEPTH: 63 M

\* DIRECTION TOWARDS

MOORING: 34

DATE: OCT 1973

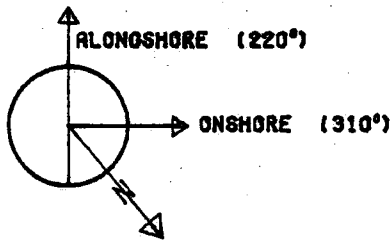

WINDSPEED<sup>2</sup>

0 40 M<sup>2</sup>/SEC<sup>2</sup>

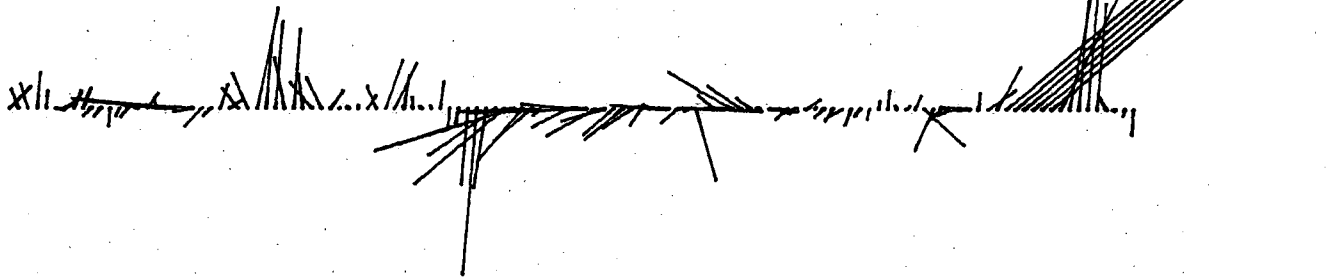

DEPTH: 10 M

FILTERED CURRENT  
(0.0 TO 0.05 CPM)

0 10 CM/SEC

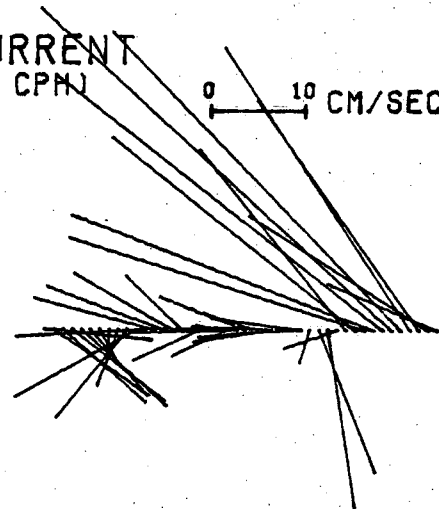

DEPTH: 63 M

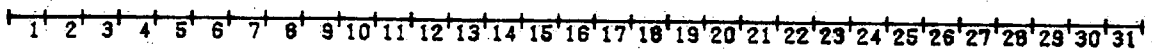
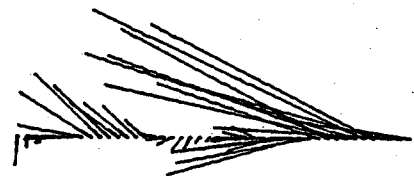

MOORING: 35      DATE: OCT 1973  
 MONTHLY SUMMARY: WIND AND CURRENT\*

WIND  
 — 0-3 M/SEC  
 = 3-7 M/SEC  
 ≡ ≥ 7 M/SEC

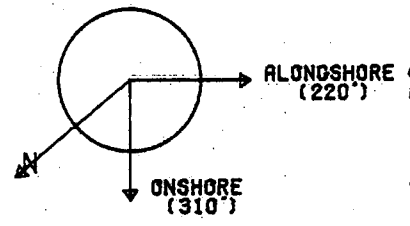
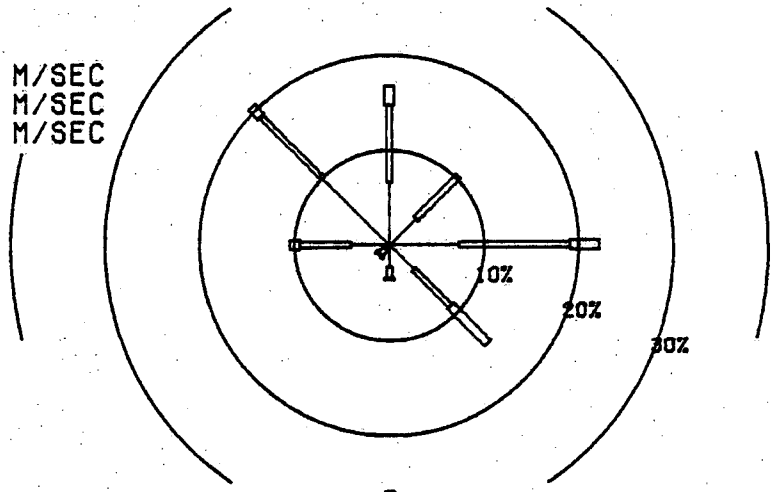

CURRENT  
 — 0-5 CM/SEC  
 = 5-15 CM/SEC  
 ≡ ≥ 15 CM/SEC

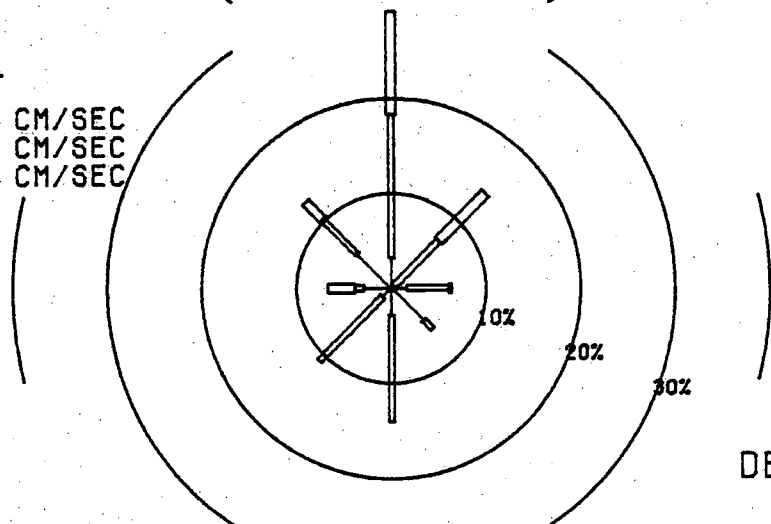

DEPTH: 10 M

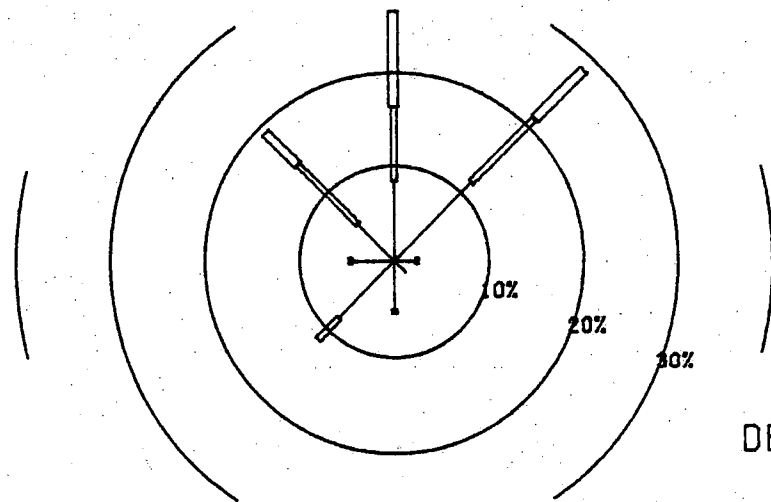

DEPTH: 64 M

\* DIRECTION TOWARDS

MOORING: 35

DATE: OCT 1973

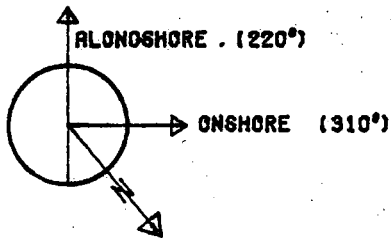

WINDSPEED<sup>2</sup>

0 40 M<sup>2</sup>/SEC<sup>2</sup>

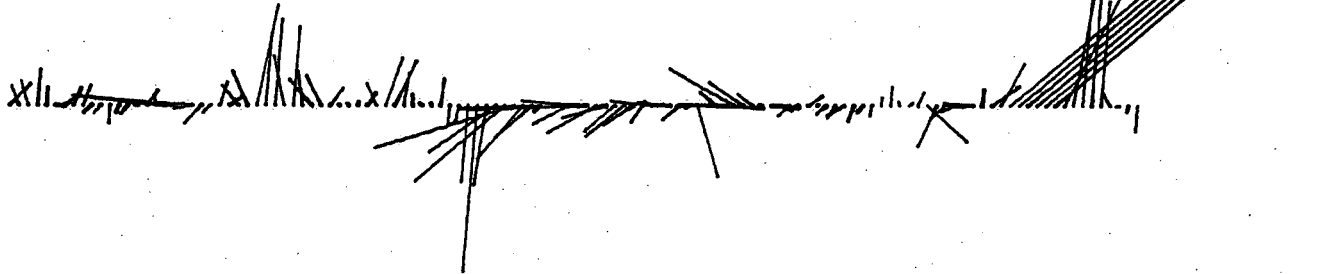

FILTERED CURRENT  
(0.0 TO 0.05 CPH)

DEPTH: 10 M

0 10 CM/SEC

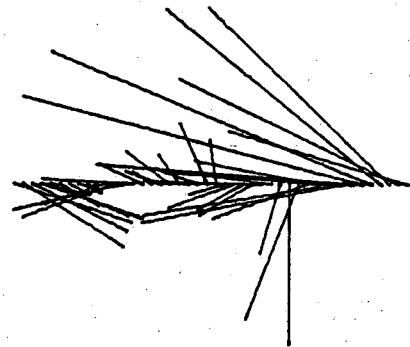

DEPTH: 64 M

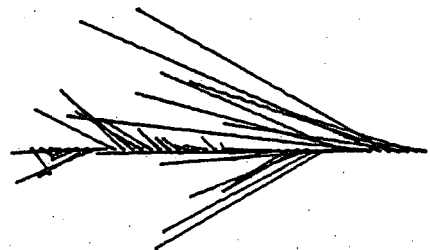

1' 2' 3' 4' 5' 6' 7' 8' 9' 10' 11' 12' 13' 14' 15' 16' 17' 18' 19' 20' 21' 22' 23' 24' 25' 26' 27' 28' 29' 30' 31'

# METEOROLOGICAL DATA

MOORING: BURLINGTON DATE: NOV 1973

FILTERED WIND (0.0 TO 0.05 CPH)

0 10 M/SEC

N  
↑



FILTERED WIND (0.0 TO 0.2 CPH) \*

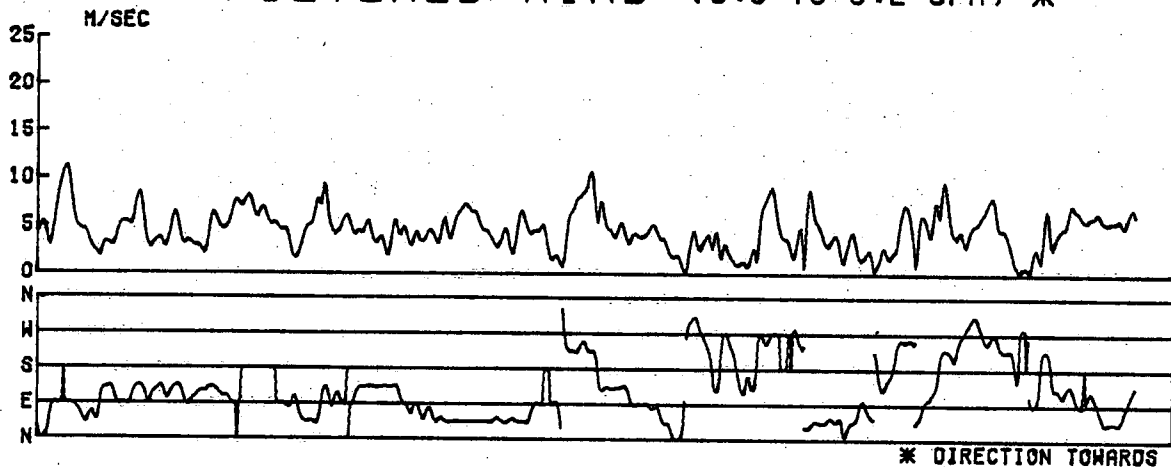

TEMPERATURE °C

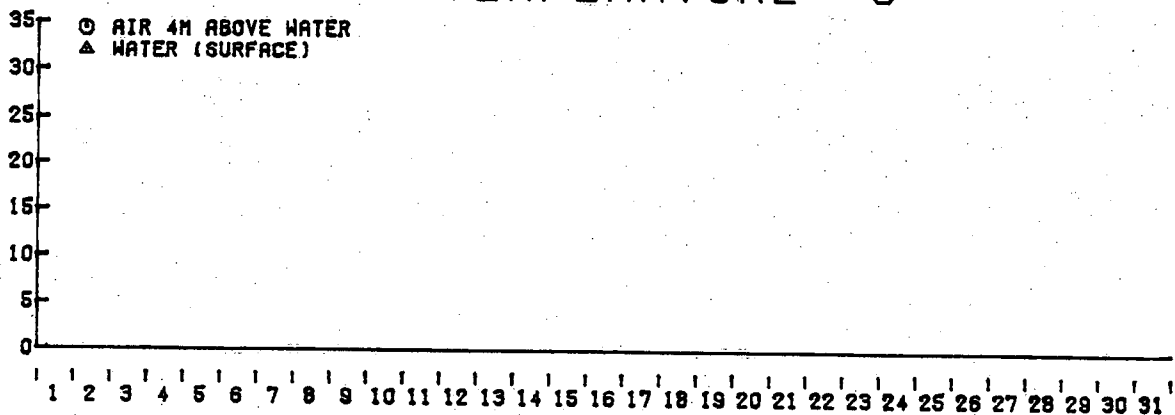

## DAILY MAXIMUM AND MINIMUM AIR TEMPERATURE

DAY	TMAX	TMIN	DAY	TMAX	TMIN	DAY	TMAX	TMIN	DAY	TMAX	TMIN
1			9			17			25		
2			10			18			26		
3			11			19			27		
4			12			20			28		
5			13			21			29		
6			14			22			30		
7			15			23			31		
8			16			24					



MOORING: 30      DATE: NOV 1973  
 MONTHLY SUMMARY: WIND AND CURRENT\*

WIND  
 — 0-3 M/SEC  
 = 3-7 M/SEC  
 ≡ ≥ 7 M/SEC

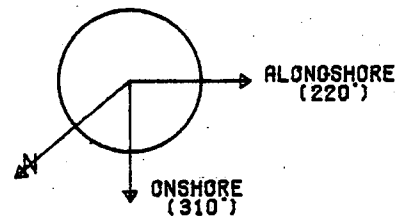
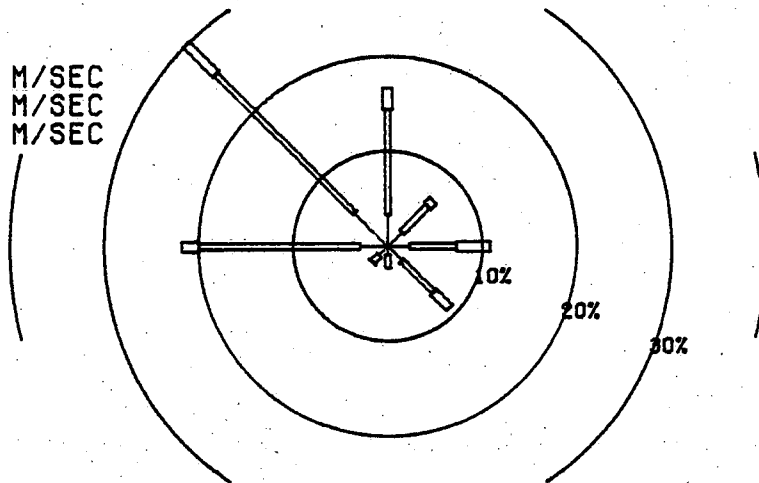

CURRENT  
 — 0-5 CM/SEC  
 = 5-15 CM/SEC  
 ≡ ≥ 15 CM/SEC

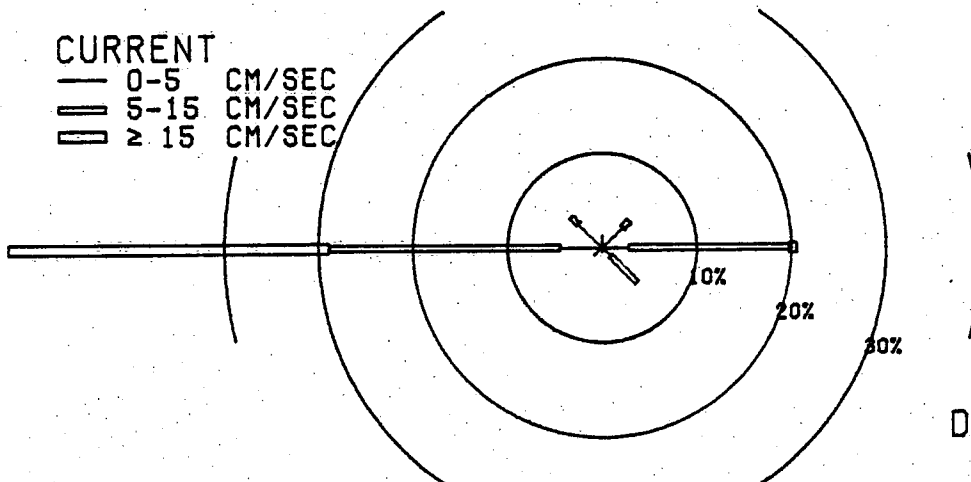

DEPTH: 10 M

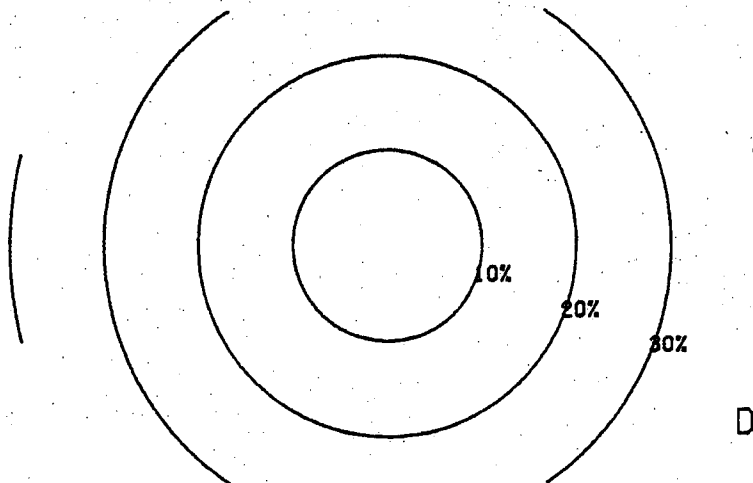

DEPTH: M

\* DIRECTION TOWARDS

MOORING : 30

DATE : NOV 1973

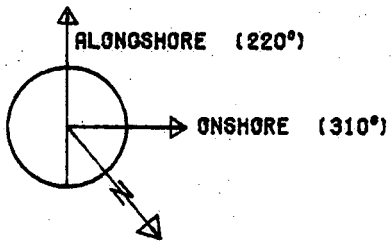

WINDSPEED<sup>2</sup>

0 40 M<sup>2</sup>/SEC<sup>2</sup>

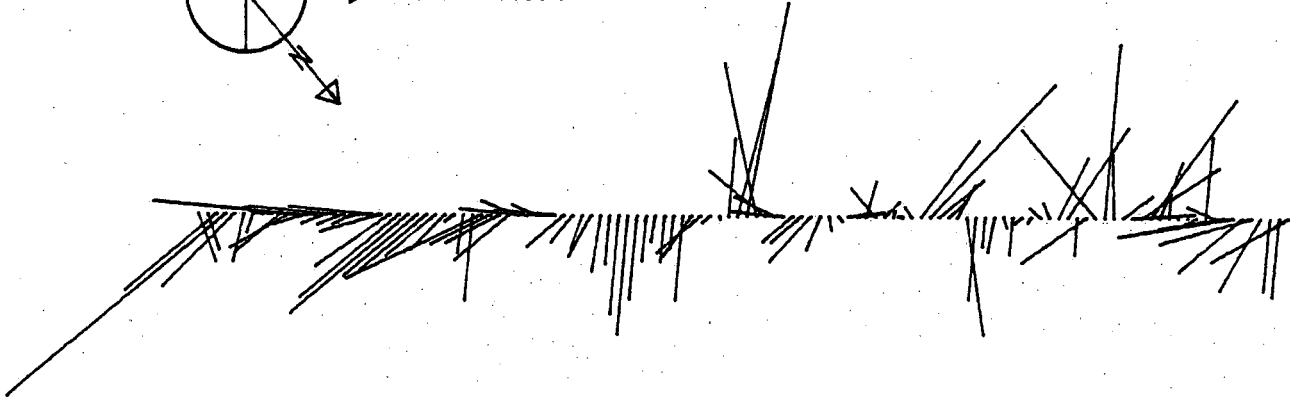

DEPTH: 10 M

FILTERED CURRENT  
(0.0 TO 0.05 CPH)

0 10 CM/SEC

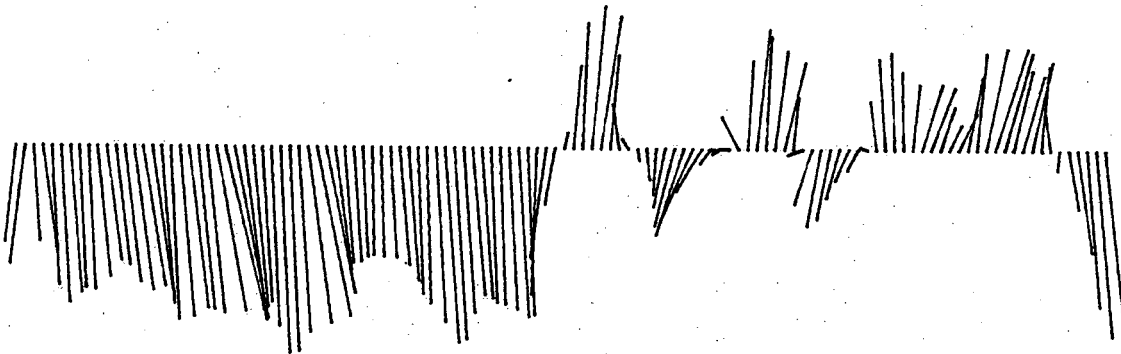

DEPTH: M

1 2 3 4 5 6 7 8 9 10 11 12 13 14 15 16 17 18 19 20 21 22 23 24 25 26 27 28 29 30 31

MOORING: 31      DATE: NOV 1973  
 MONTHLY SUMMARY: WIND AND CURRENT\*

WIND  
 — 0-3 M/SEC  
 = 3-7 M/SEC  
 ≡ ≥ 7 M/SEC

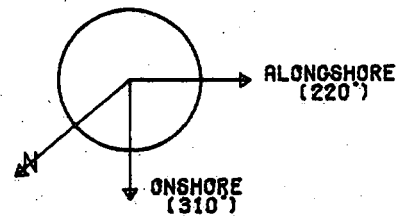
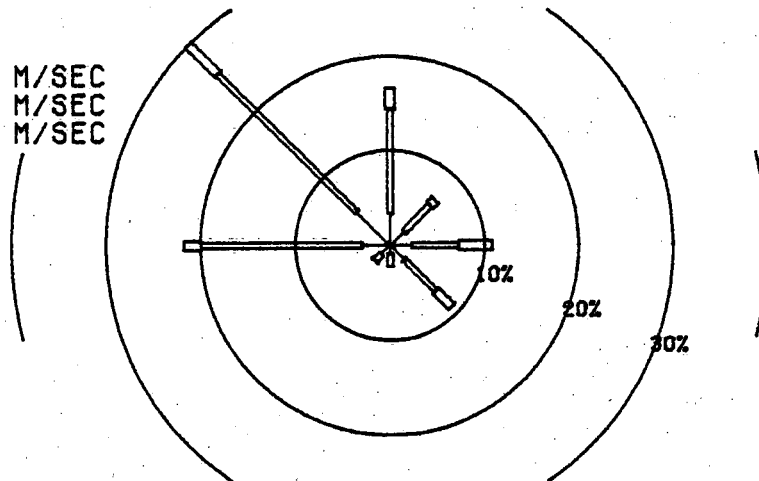

CURRENT  
 — 0-5 CM/SEC  
 = 5-15 CM/SEC  
 ≡ ≥ 15 CM/SEC

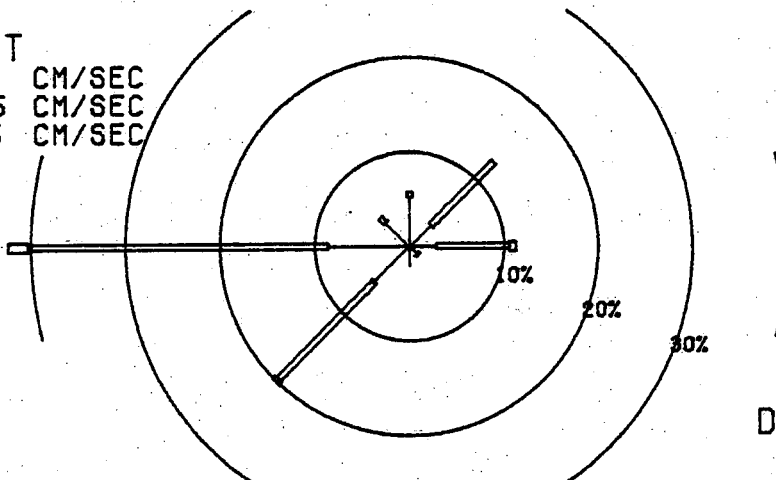

DEPTH: 10 M

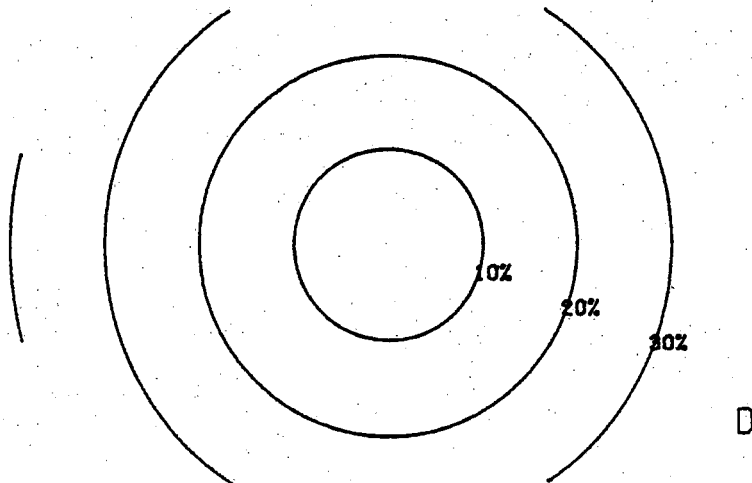

DEPTH: M

\* DIRECTION TOWARDS

MOORING : 31

DATE : NOV 1973

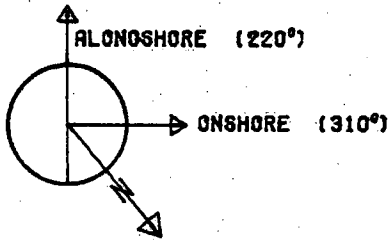

WINDSPEED<sup>2</sup>

0 40 M<sup>2</sup>/SEC<sup>2</sup>

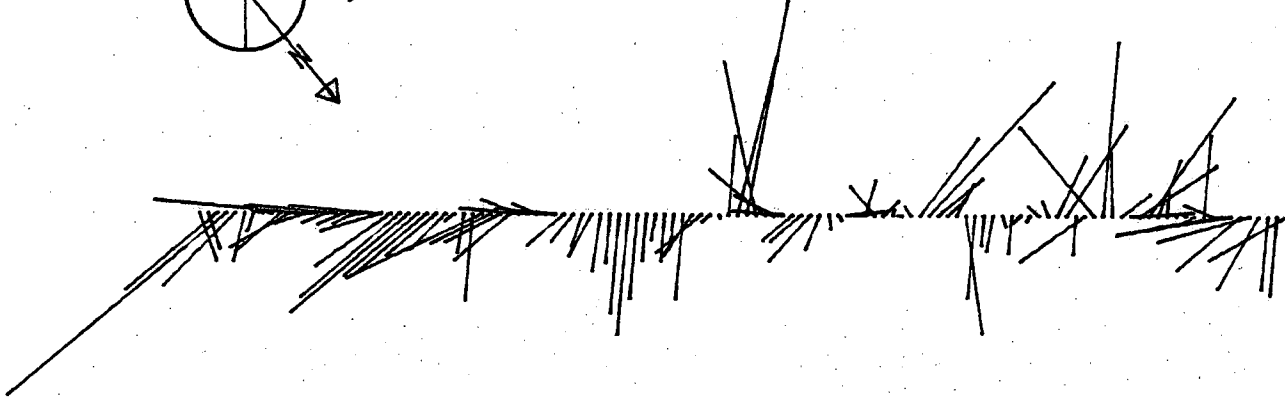

FILTERED CURRENT  
(0.0 TO 0.05 CPH)

DEPTH: 10 M

0 10 CM/SEC

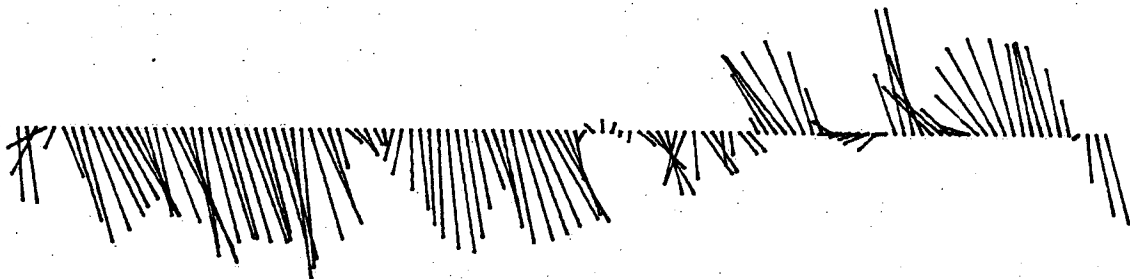

DEPTH: M

1 2 3 4 5 6 7 8 9 10 11 12 13 14 15 16 17 18 19 20 21 22 23 24 25 26 27 28 29 30 31

MOORING: 32      DATE: NOV 1973  
 MONTHLY SUMMARY: WIND AND CURRENT\*

WIND  
 — 0-3 M/SEC  
 = 3-7 M/SEC  
 ≡ ≥ 7 M/SEC

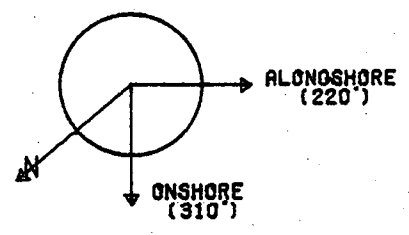
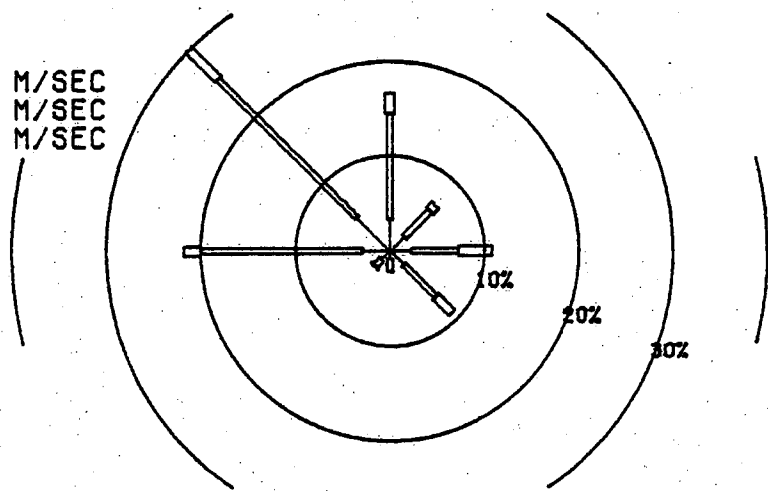

CURRENT  
 — 0-5 CM/SEC  
 = 5-15 CM/SEC  
 ≡ ≥ 15 CM/SEC

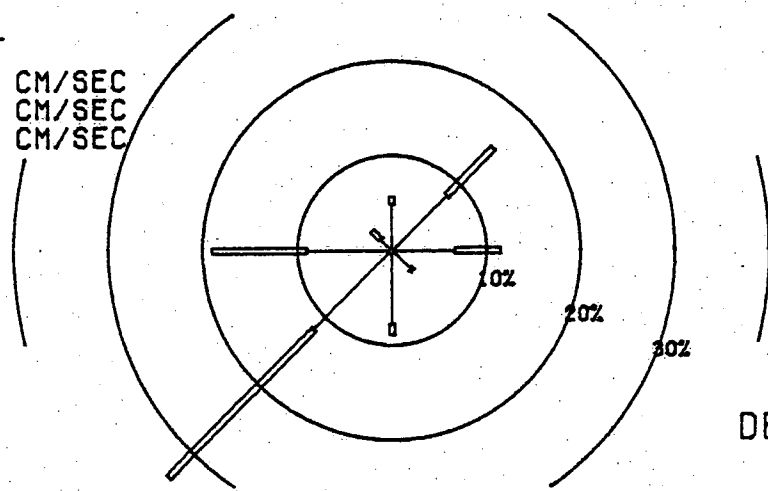

DEPTH: 10 M

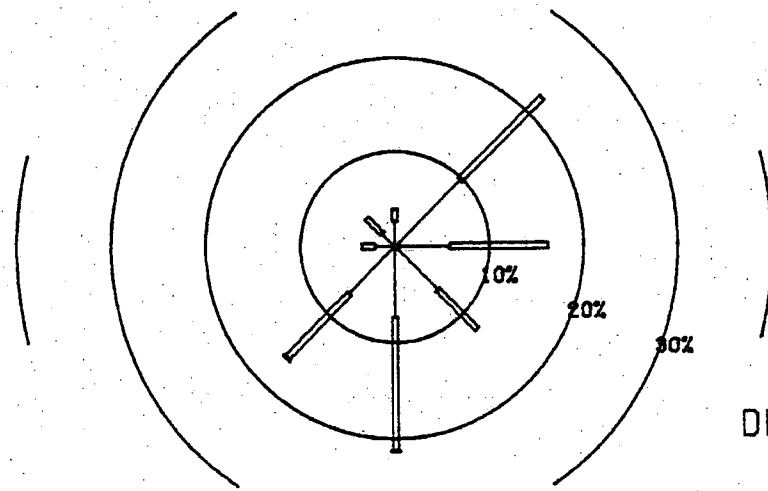

DEPTH: 51 M

\* DIRECTION TOWARDS

MOORING: 32

DATE: NOV 1973

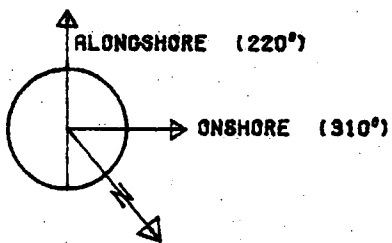

WINDSPEED<sup>2</sup>

0 40 M<sup>2</sup>/SEC<sup>2</sup>

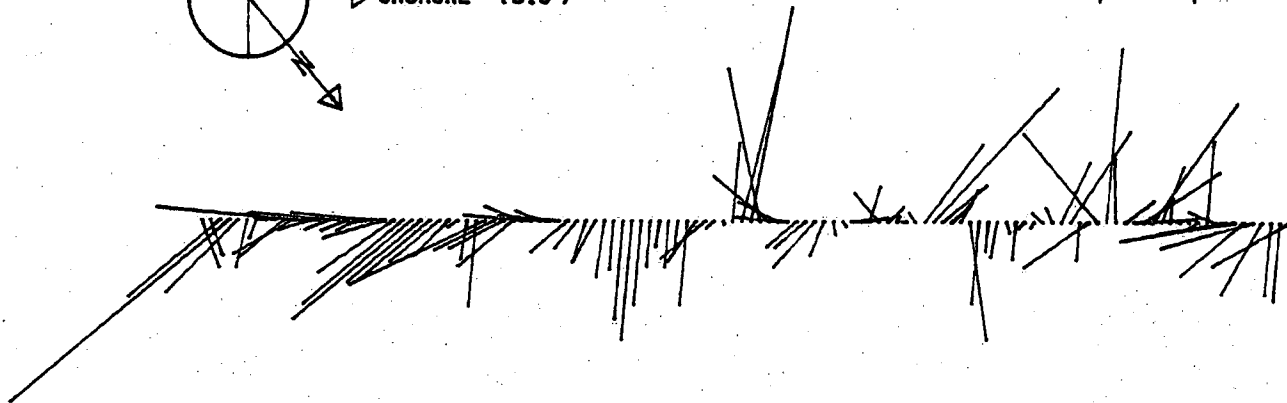

FILTERED CURRENT  
(0.0 TO 0.05 CPH)

DEPTH: 10 M

0 10 CM/SEC

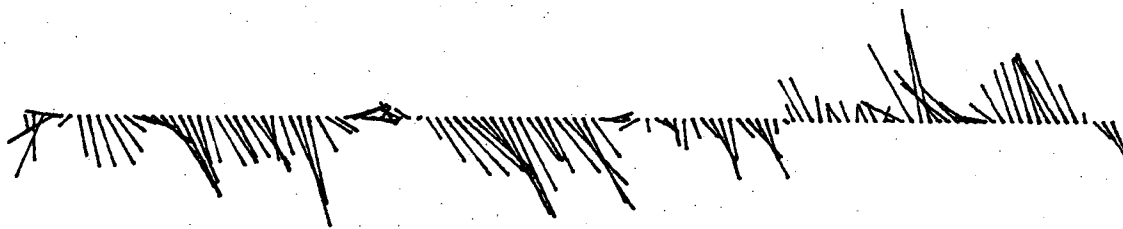

DEPTH: 51 M

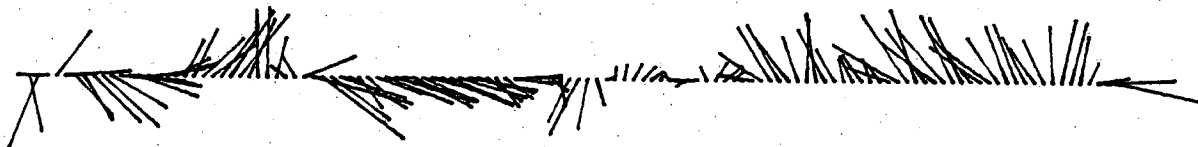

1 2 3 4 5 6 7 8 9 10 11 12 13 14 15 16 17 18 19 20 21 22 23 24 25 26 27 28 29 30 31

MOORING: 33      DATE: NOV 1973  
 MONTHLY SUMMARY: WIND AND CURRENT\*

WIND  
 — 0-3 M/SEC  
 = 3-7 M/SEC  
 ≡ ≥ 7 M/SEC

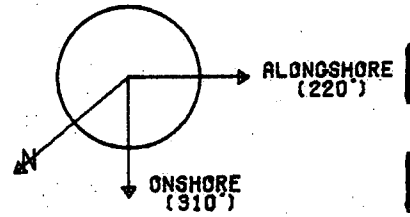
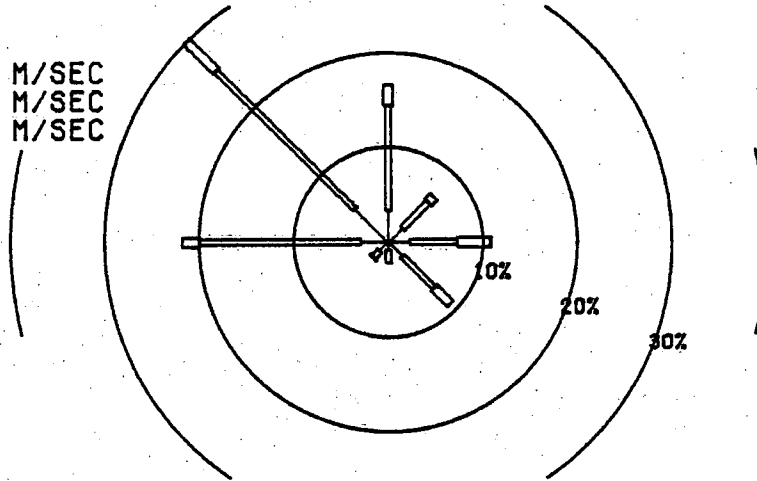

CURRENT  
 — 0-5 CM/SEC  
 = 5-15 CM/SEC  
 ≡ ≥ 15 CM/SEC

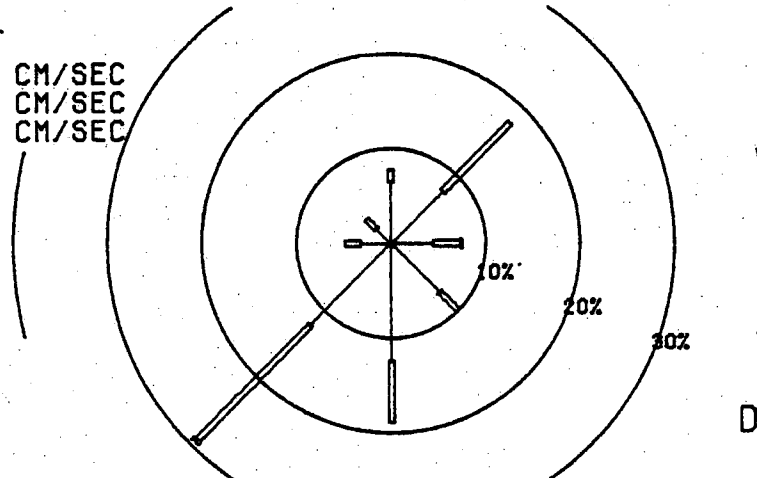

DEPTH: 10 M

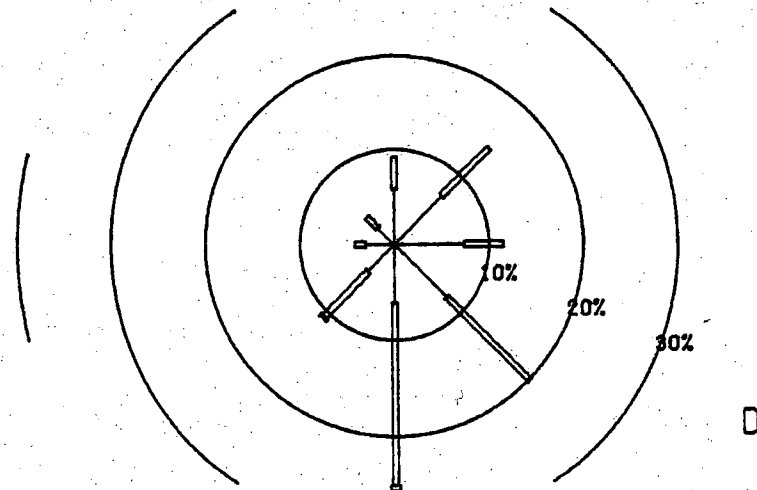

DEPTH: 61 M

\* DIRECTION TOWARDS

MOORING: 33

DATE: NOV 1973

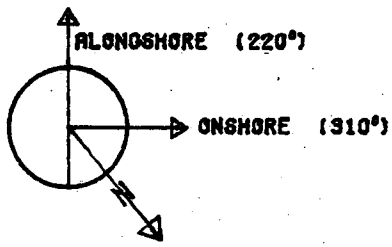

WINDSPEED<sup>2</sup>

0 40 M<sup>2</sup>/SEC<sup>2</sup>

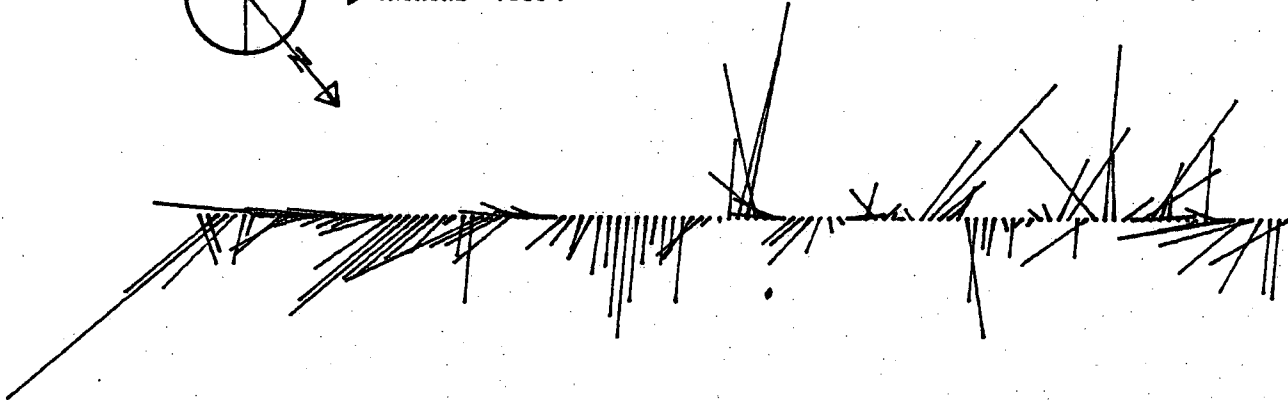

FILTERED CURRENT  
(0.0 TO 0.05 CPH)

DEPTH: 10 M

0 10 CM/SEC

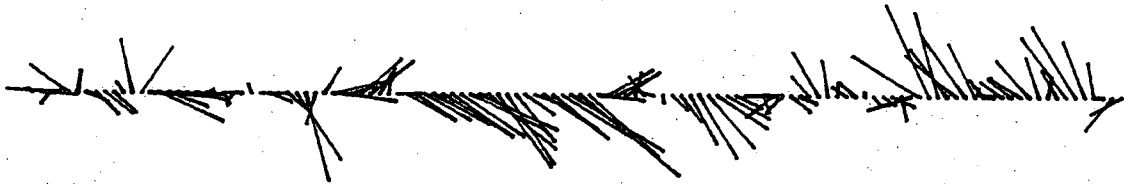

DEPTH: 61 M

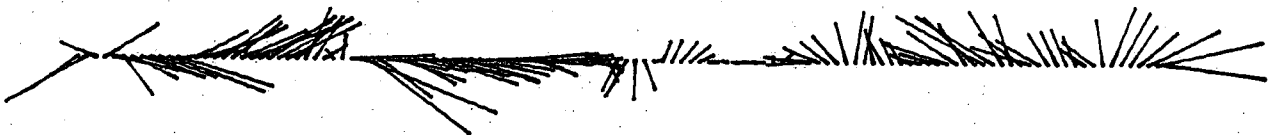

1' 2' 3' 4' 5' 6' 7' 8' 9' 10' 11' 12' 13' 14' 15' 16' 17' 18' 19' 20' 21' 22' 23' 24' 25' 26' 27' 28' 29' 30' 31'



MOORING: 34      DATE: NOV 1973  
 MONTHLY SUMMARY: WIND AND CURRENT\*

WIND  
 — 0-3 M/SEC  
 = 3-7 M/SEC  
 ≡ ≥ 7 M/SEC

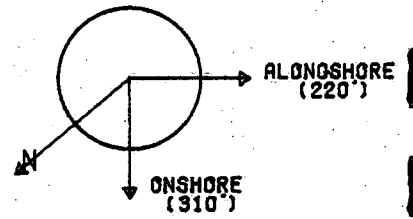
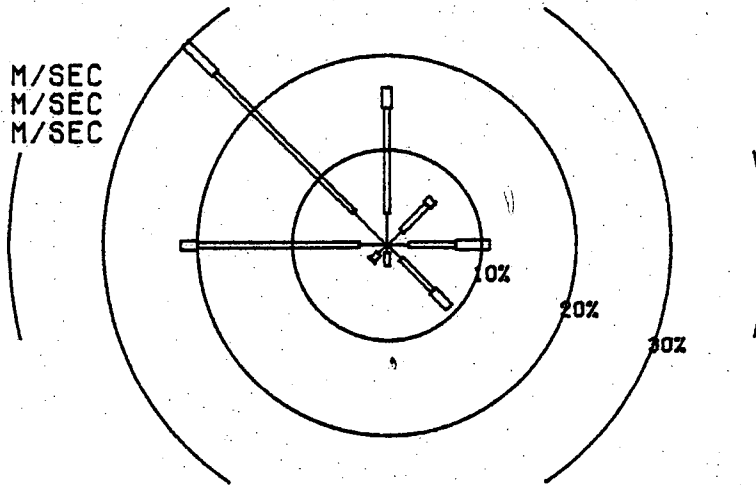

CURRENT  
 — 0-5 CM/SEC  
 = 5-15 CM/SEC  
 ≡ ≥ 15 CM/SEC

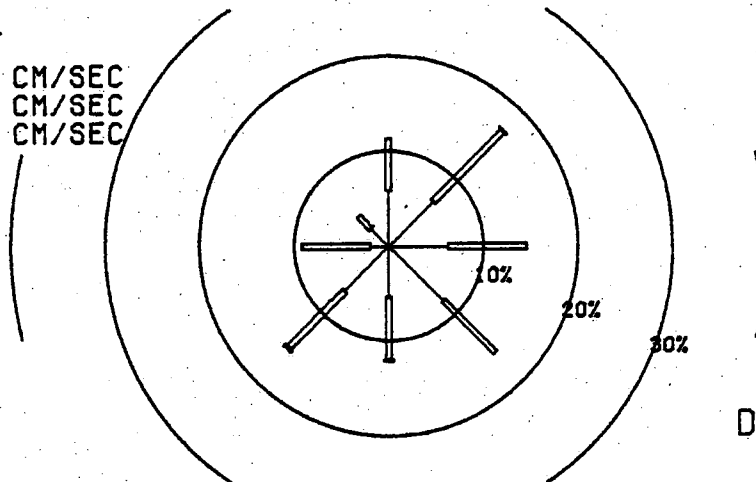

DEPTH: 10 M

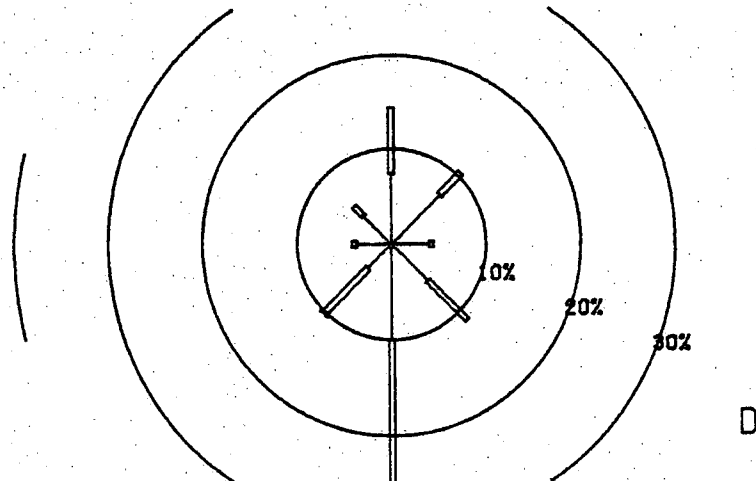

DEPTH: 63 M

\* DIRECTION TOWARDS

MOORING: 34

DATE: NOV 1973

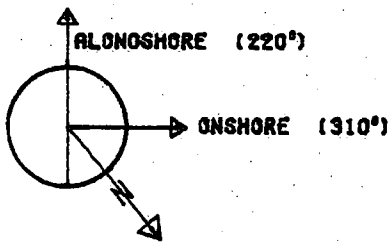

WINDSPEED<sup>2</sup>

0 40 M<sup>2</sup>/SEC<sup>2</sup>

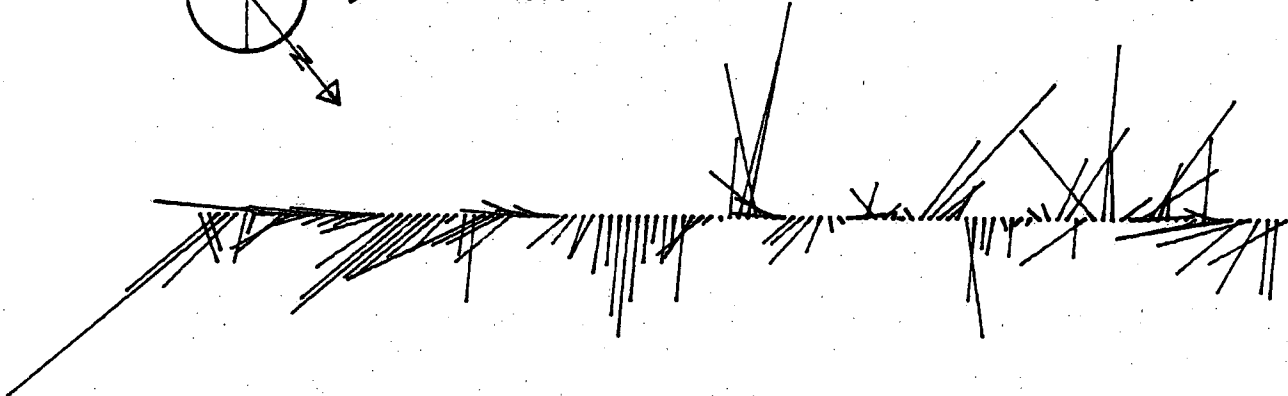

FILTERED CURRENT  
(0.0 TO 0.05 CPH)

DEPTH: 10 M

0 10 CM/SEC

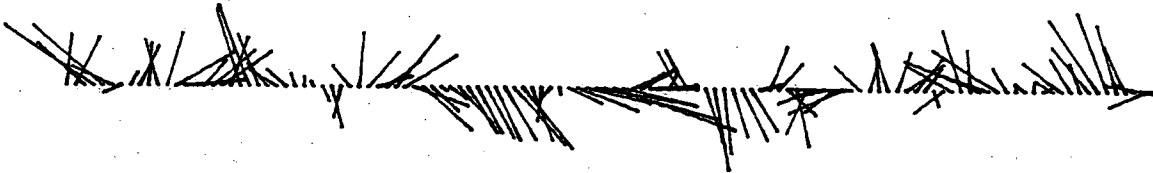

DEPTH: 63 M

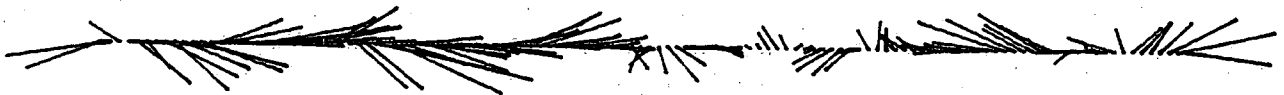

1' 2' 3' 4' 5' 6' 7' 8' 9' 10' 11' 12' 13' 14' 15' 16' 17' 18' 19' 20' 21' 22' 23' 24' 25' 26' 27' 28' 29' 30' 31'

MOORING: 35      DATE: NOV 1973  
 MONTHLY SUMMARY: WIND AND CURRENT\*

WIND  
 — 0-3 M/SEC  
 = 3-7 M/SEC  
 ≡ ≥ 7 M/SEC

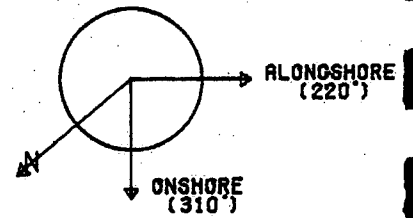
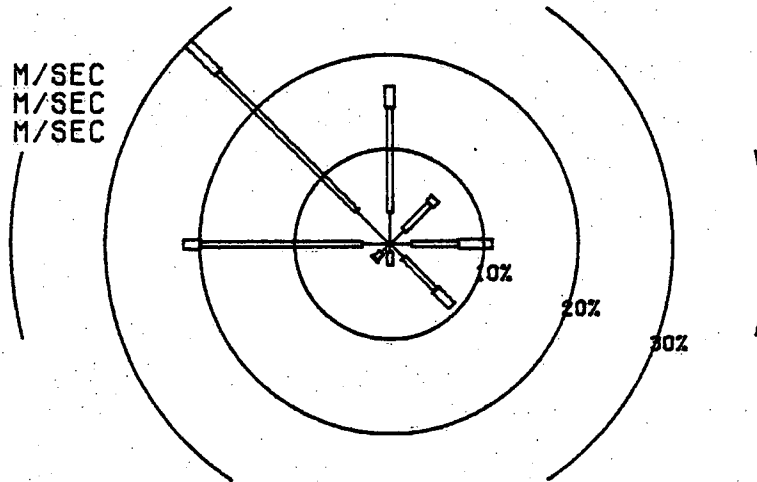

CURRENT  
 — 0-5 CM/SEC  
 = 5-15 CM/SEC  
 ≡ ≥ 15 CM/SEC

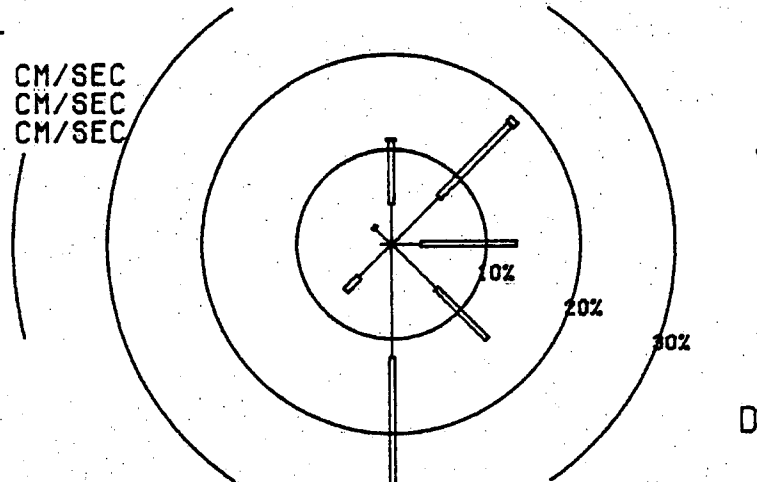

DEPTH: 10 M

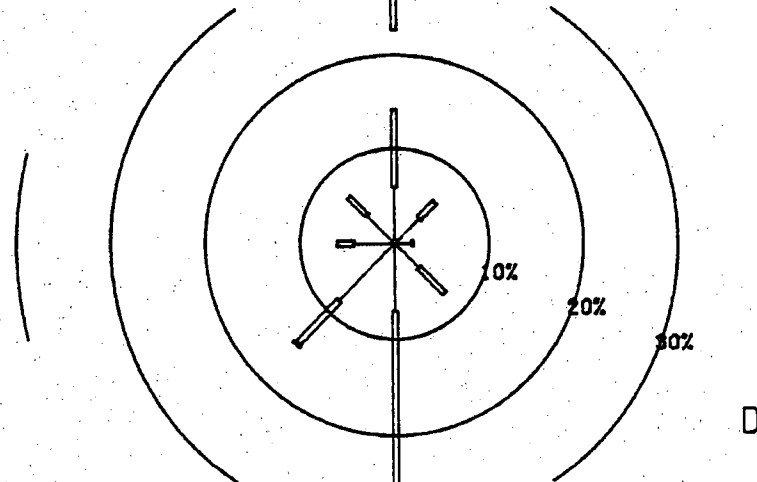

DEPTH: 64 M

\* DIRECTION TOWARDS

MOORING: 35

DATE: NOV 1973

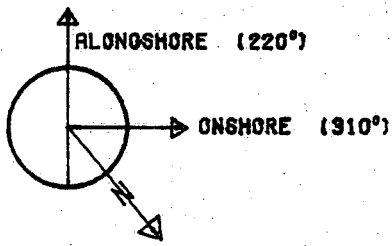

WINDSPEED<sup>2</sup>

0 40 M<sup>2</sup>/SEC<sup>2</sup>

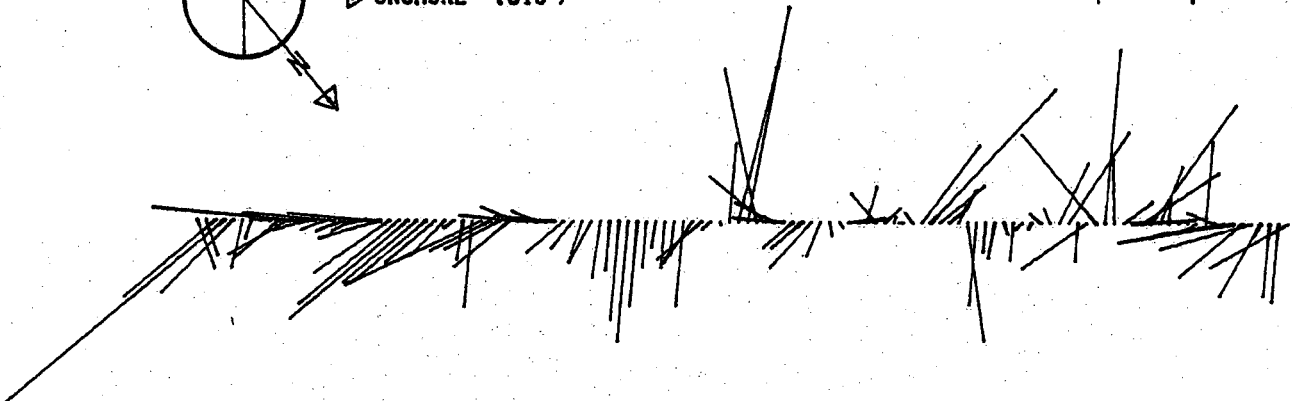

DEPTH: 10 M

FILTERED CURRENT  
(0.0 TO 0.05 CPH)

0 10 CM/SEC



DEPTH: 64 M

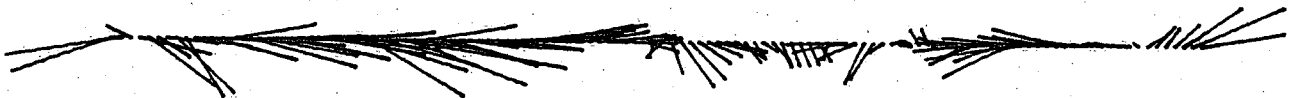

1 2 3 4 5 6 7 8 9 10 11 12 13 14 15 16 17 18 19 20 21 22 23 24 25 26 27 28 29 30 31

# METEOROLOGICAL DATA

MOORING: BURLINGTON DATE: DEC 1973

## FILTERED WIND (0.0 TO 0.05 CPH)

0 10 M/SEC

N  
↑



## FILTERED WIND (0.0 TO 0.2 CPH) \*

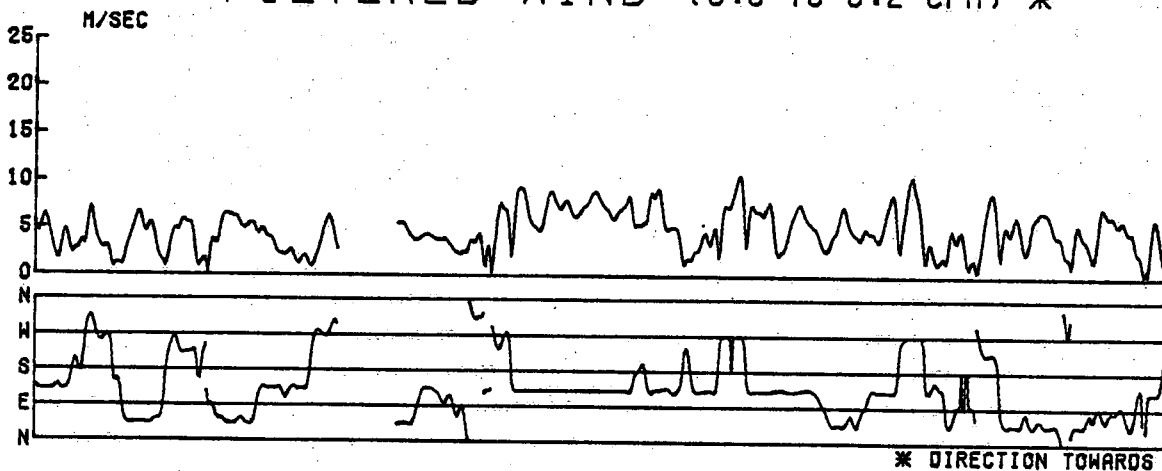

## TEMPERATURE °C

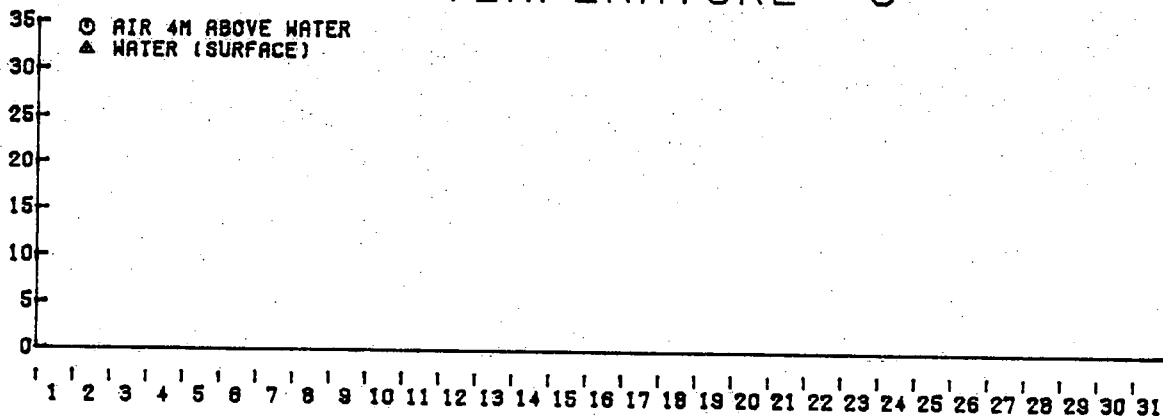

### DAILY MAXIMUM AND MINIMUM AIR TEMPERATURE

DAY	TMAX	TMIN	DAY	TMAX	TMIN	DAY	TMAX	TMIN	DAY	TMAX	TMIN
1			9			17			25		
2			10			18			26		
3			11			19			27		
4			12			20			28		
5			13			21			29		
6			14			22			30		
7			15			23			31		
8			16			24					

MOORING: 30      DATE: DEC 1973  
 MONTHLY SUMMARY: WIND AND CURRENT\*

WIND  
 — 0-3 M/SEC  
 = 3-7 M/SEC  
 ≡ ≥ 7 M/SEC

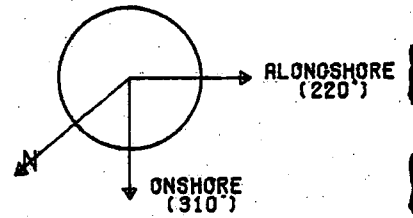
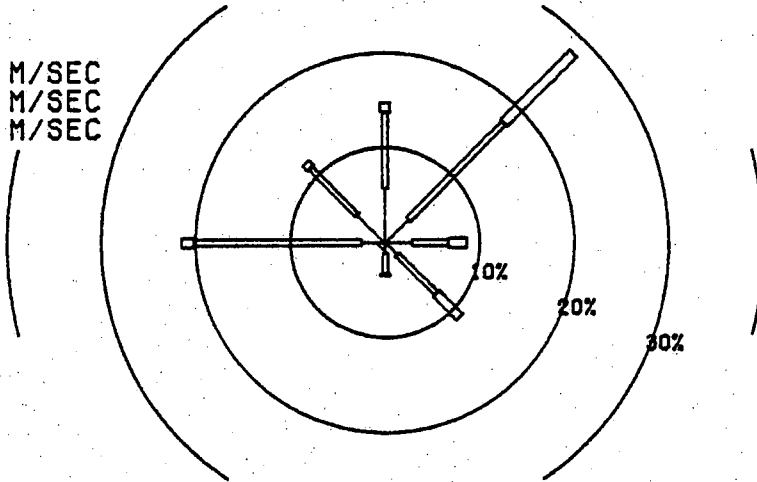

CURRENT  
 — 0-5 CM/SEC  
 = 5-15 CM/SEC  
 ≡ ≥ 15 CM/SEC

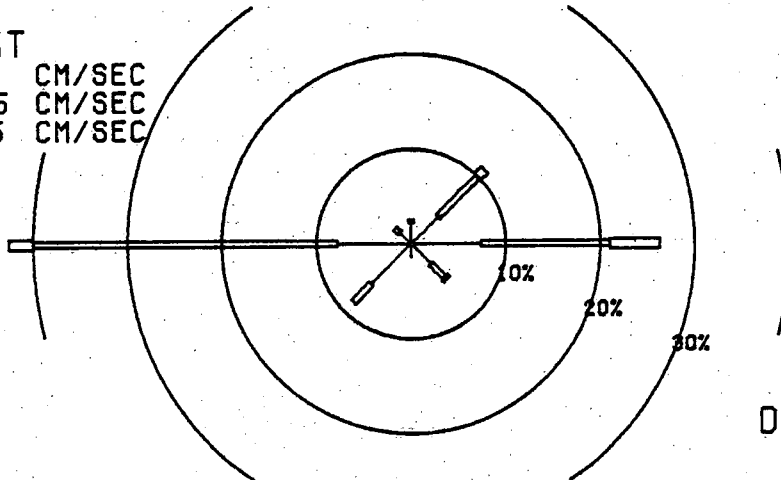

DEPTH: 10 M

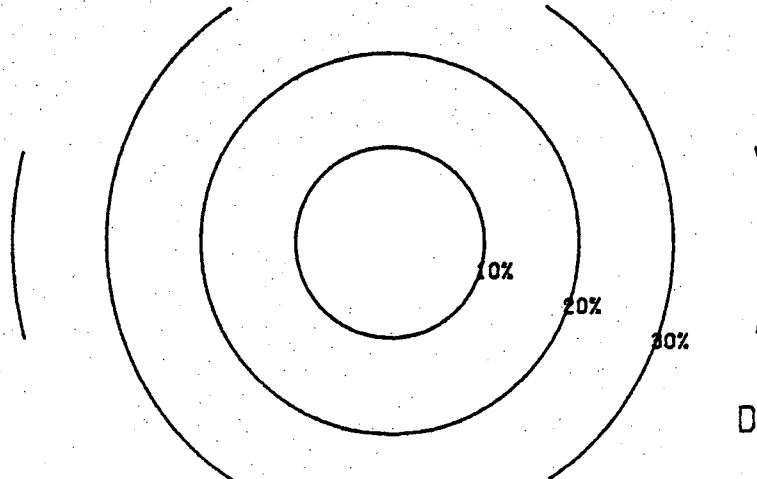

DEPTH: M

\* DIRECTION TOWARDS

MOORING : 30

DATE : DEC 1973

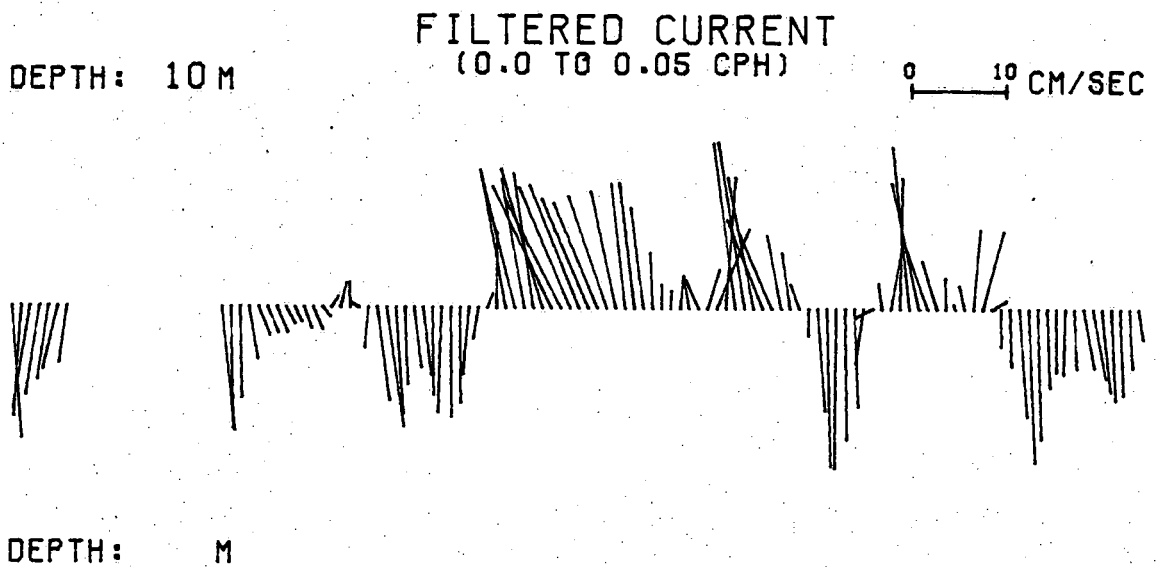
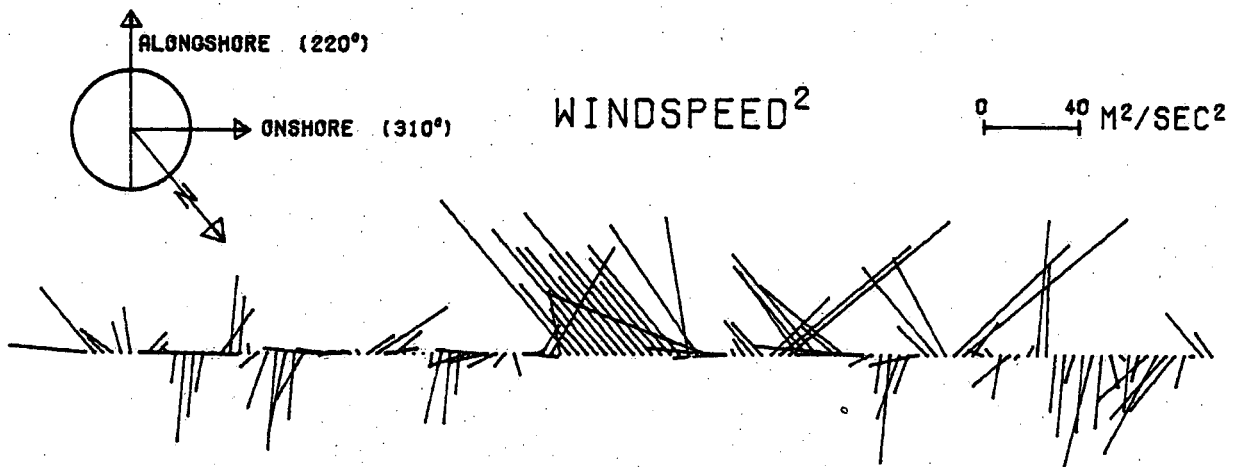

1 2 3 4 5 6 7 8 9 10 11 12 13 14 15 16 17 18 19 20 21 22 23 24 25 26 27 28 29 30 31

MOORING: 31      DATE: DEC 1973  
 MONTHLY SUMMARY: WIND AND CURRENT\*

WIND  
 — 0-3 M/SEC  
 = 3-7 M/SEC  
 ≡ ≥ 7 M/SEC

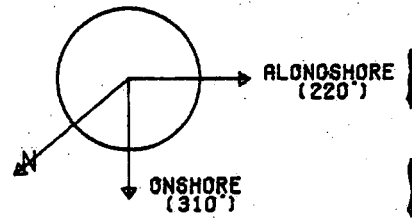
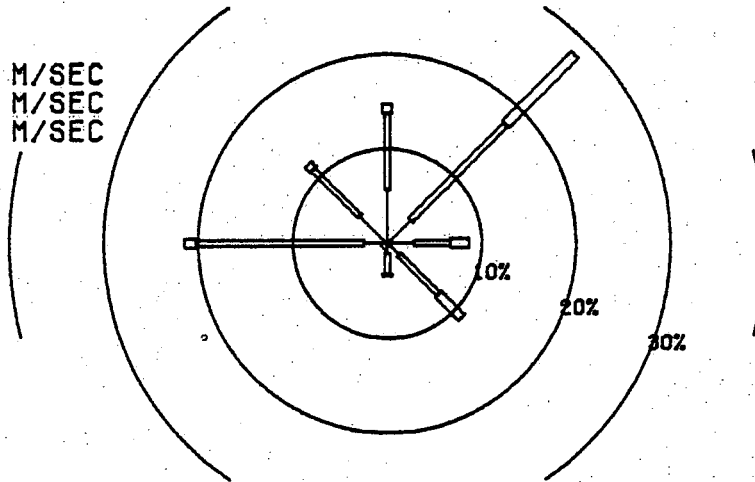

CURRENT  
 — 0-5 CM/SEC  
 = 5-15 CM/SEC  
 ≡ ≥ 15 CM/SEC

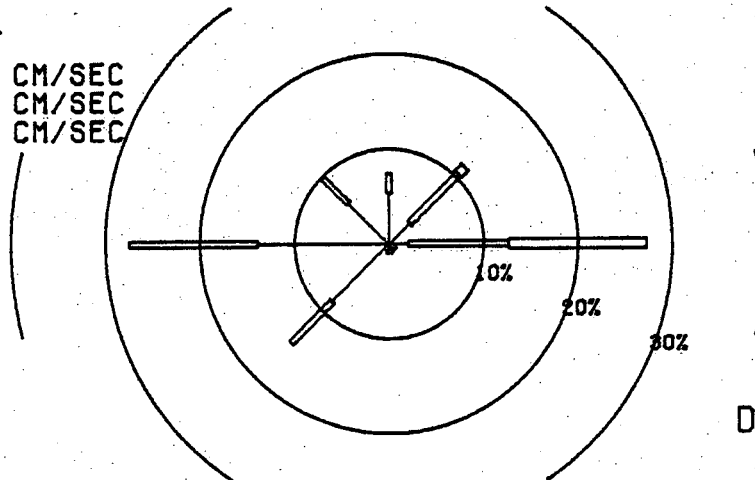

DEPTH: 10 M

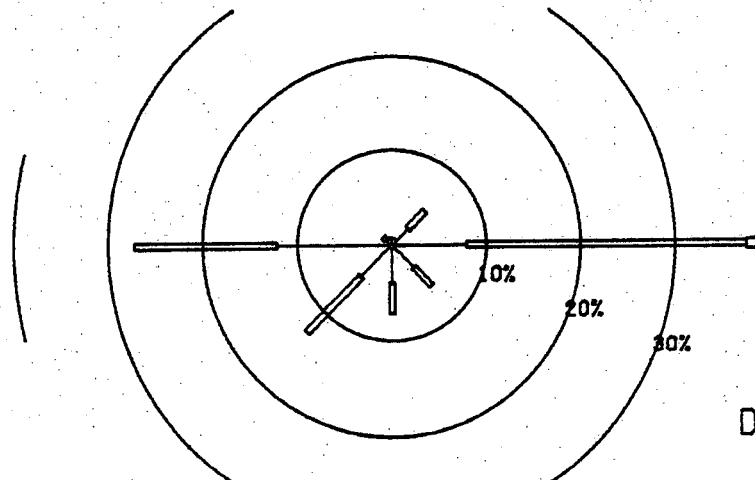

DEPTH: 38 M

\* DIRECTION TOWARDS



MOORING : 31

DATE : DEC 1973

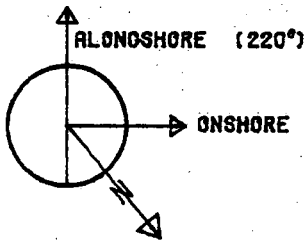

WINDSPEED<sup>2</sup>

0 40 M<sup>2</sup>/SEC<sup>2</sup>

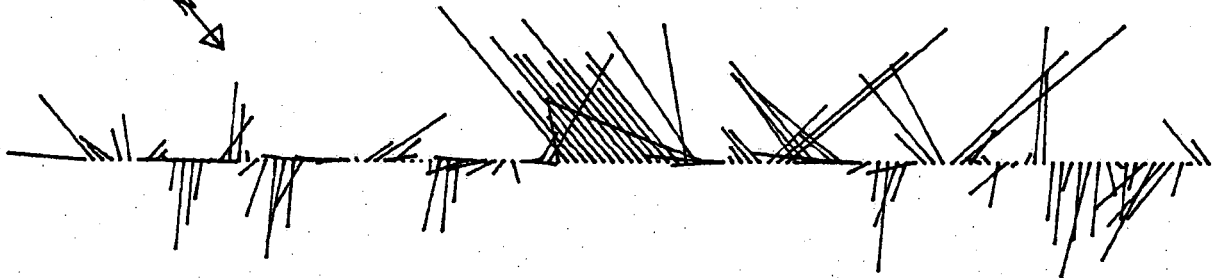

FILTERED CURRENT  
(0.0 TO 0.05 CPH)

DEPTH: 10 M

0 10 CM/SEC

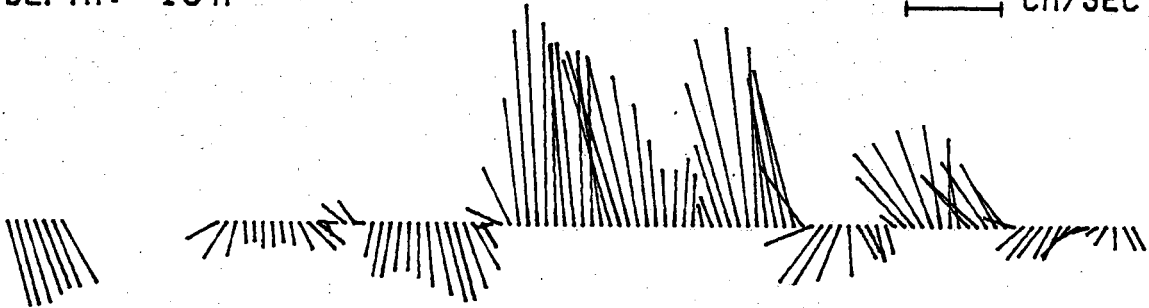

DEPTH: 38 M

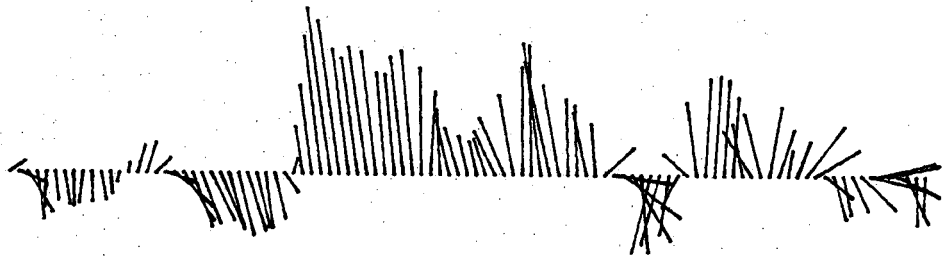

1 2 3 4 5 6 7 8 9 10 11 12 13 14 15 16 17 18 19 20 21 22 23 24 25 26 27 28 29 30 31

MOORING: 32      DATE: DEC 1973  
 MONTHLY SUMMARY: WIND AND CURRENT\*

WIND  
 — 0-3 M/SEC  
 = 3-7 M/SEC  
 ≡ ≥ 7 M/SEC

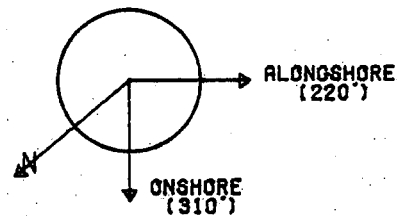
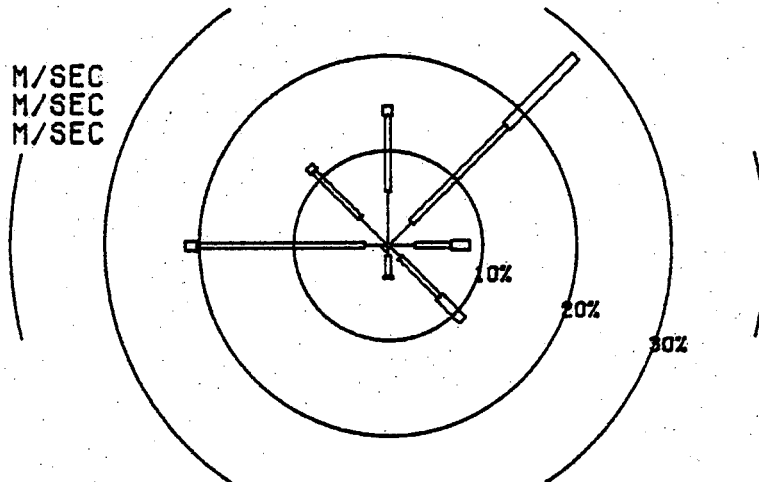

CURRENT  
 — 0-5 CM/SEC  
 = 5-15 CM/SEC  
 ≡ ≥ 15 CM/SEC

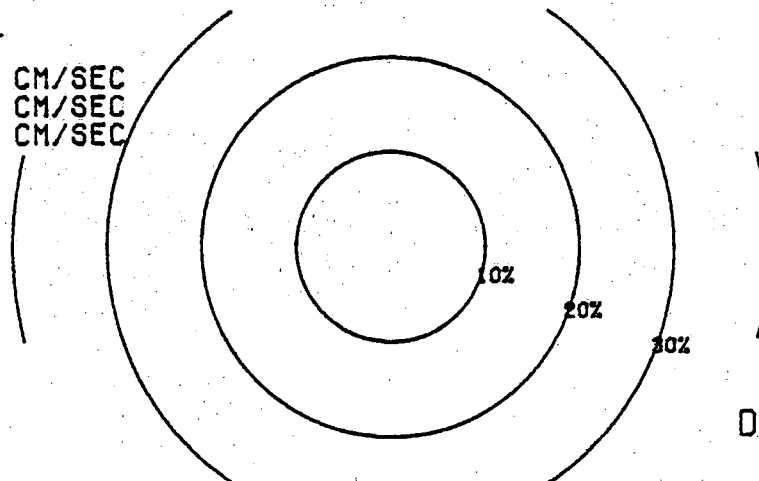

DEPTH: M

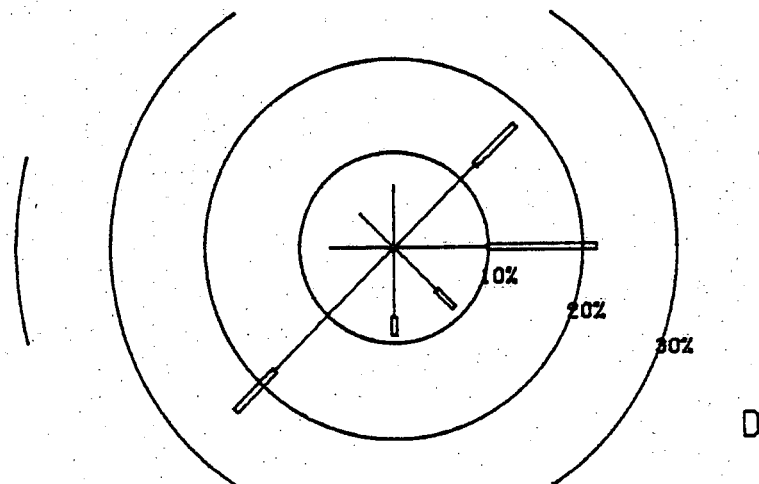

DEPTH: 51 M

\* DIRECTION TOWARDS

MOORING: 32

DATE: DEC 1973

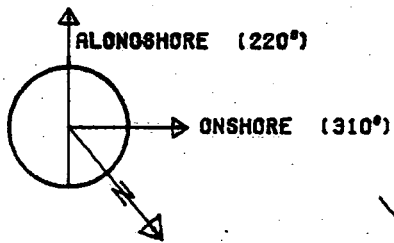

WINDSPEED<sup>2</sup>

0 40 M<sup>2</sup>/SEC<sup>2</sup>

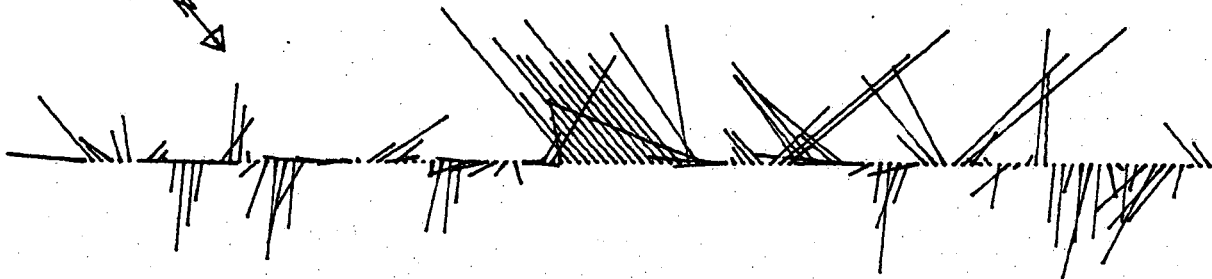

FILTERED CURRENT  
(0.0 TO 0.05 CPH)

DEPTH: 10 M

0 10 CM/SEC



DEPTH: 51 M

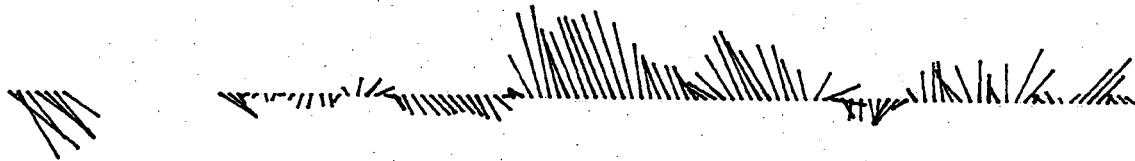

1 2 3 4 5 6 7 8 9 10 11 12 13 14 15 16 17 18 19 20 21 22 23 24 25 26 27 28 29 30 31

MOORING: 33      DATE: DEC 1973  
 MONTHLY SUMMARY: WIND AND CURRENT\*

WIND  
 — 0-3 M/SEC  
 = 3-7 M/SEC  
 ≡ ≥ 7 M/SEC

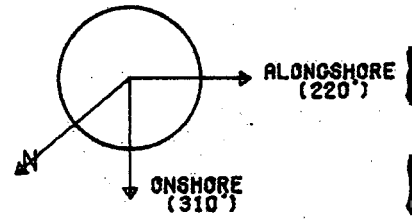
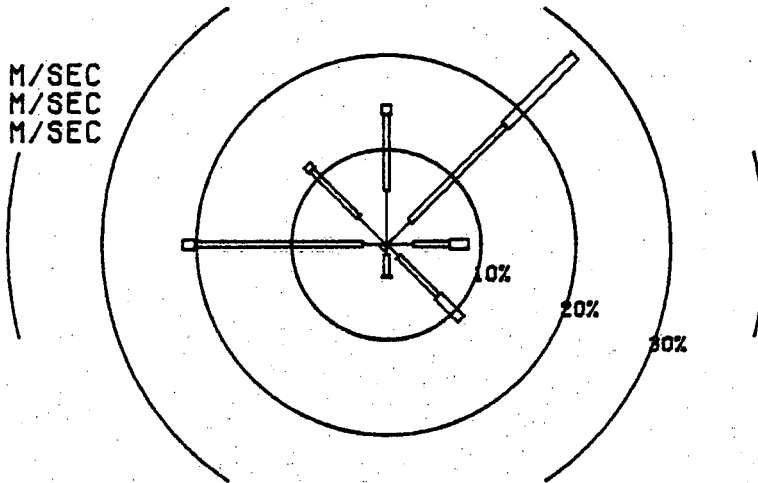

CURRENT  
 — 0-5 CM/SEC  
 = 5-15 CM/SEC  
 ≡ ≥ 15 CM/SEC

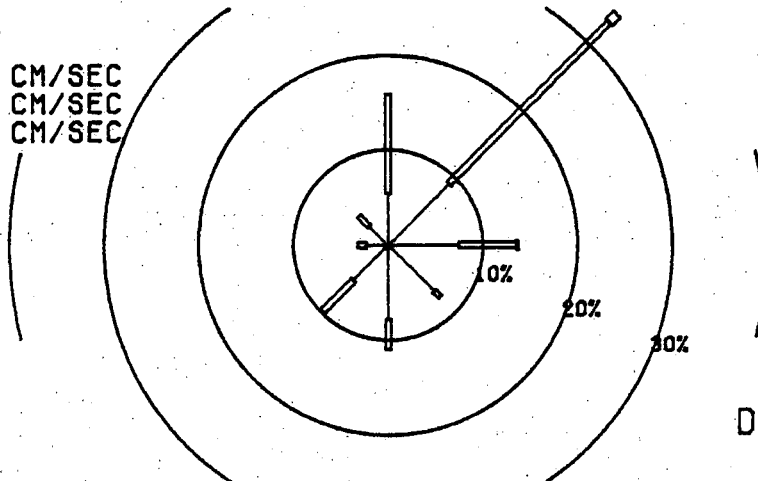

DEPTH: 10 M

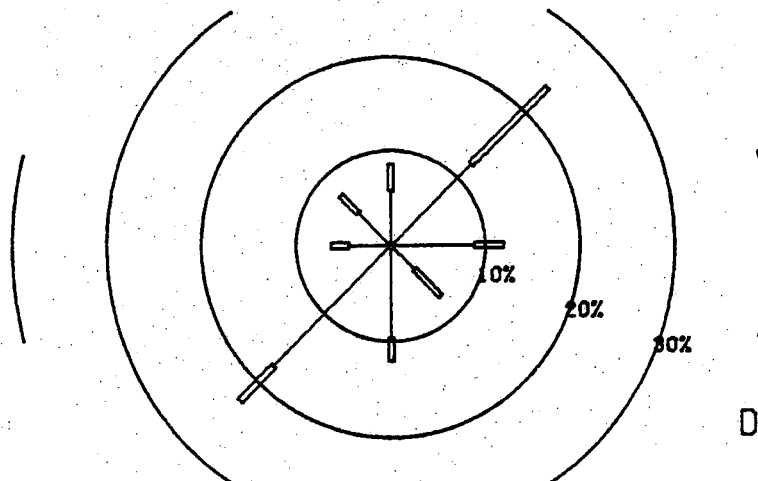

DEPTH: 61 M

\* DIRECTION TOWARDS

MOORING: 33

DATE: DEC 1973

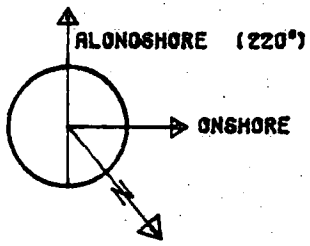

WINDSPEED<sup>2</sup>

0 40 M<sup>2</sup>/SEC<sup>2</sup>

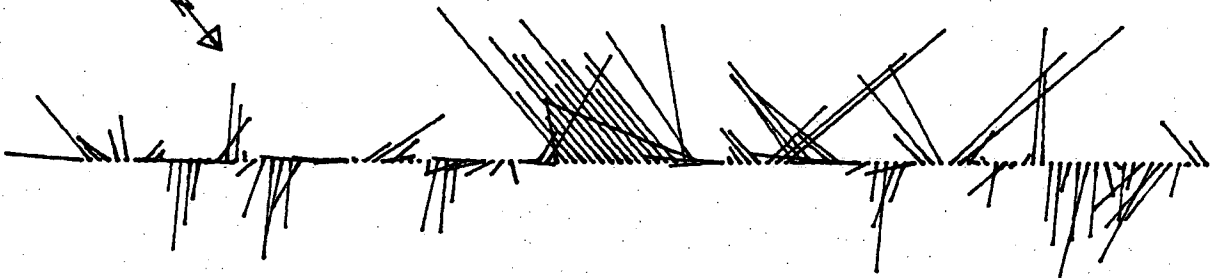

FILTERED CURRENT  
(0.0 TO 0.05 CPH)

DEPTH: 10 M

0 10 CM/SEC

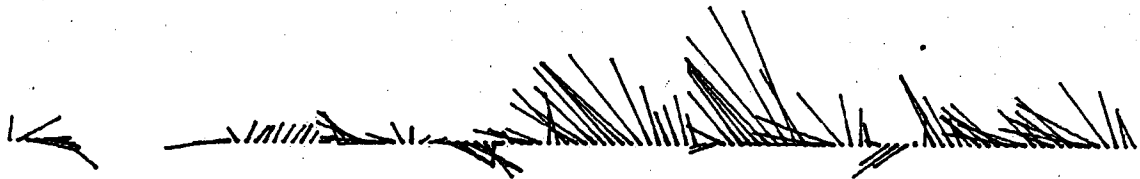

DEPTH: 61 M

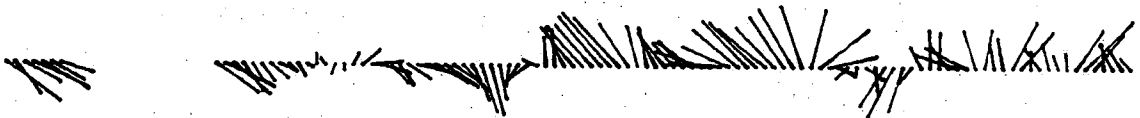

1 2 3 4 5 6 7 8 9 10 11 12 13 14 15 16 17 18 19 20 21 22 23 24 25 26 27 28 29 30 31

MOORING: 34

DATE: DEC 1973

MONTHLY SUMMARY: WIND AND CURRENT\*

WIND  
— 0-3 M/SEC  
= 3-7 M/SEC  
▬ ≥ 7 M/SEC

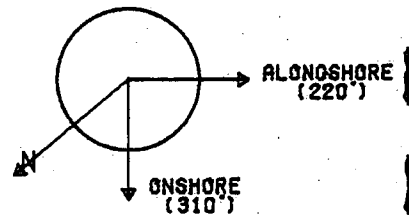
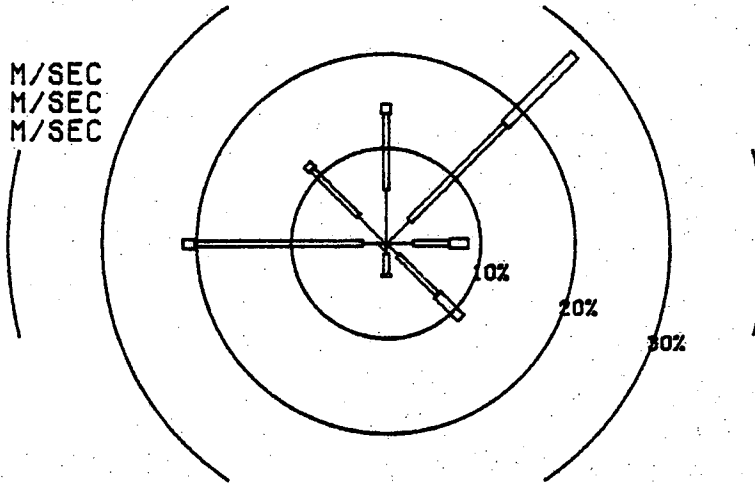

CURRENT  
— 0-5 CM/SEC  
= 5-15 CM/SEC  
▬ ≥ 15 CM/SEC

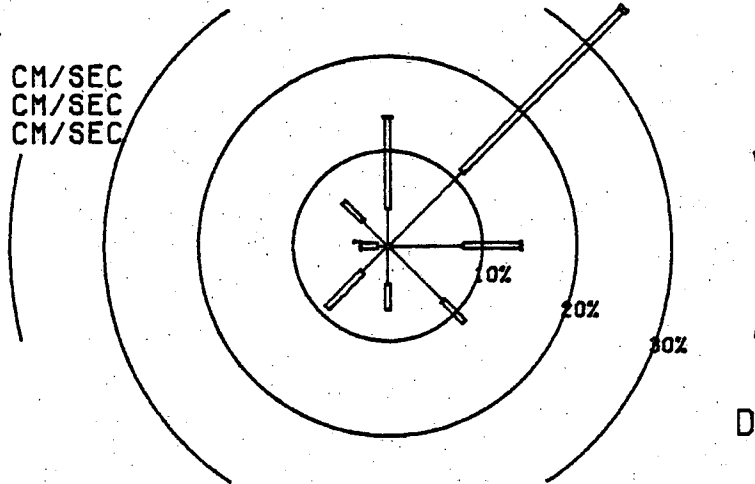

DEPTH: 10 M

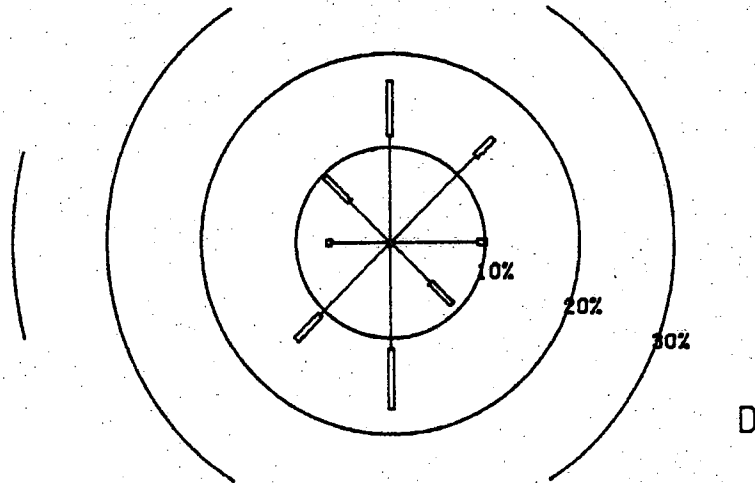

DEPTH: 63 M

\* DIRECTION TOWARDS

MOORING: 34

DATE: DEC 1973

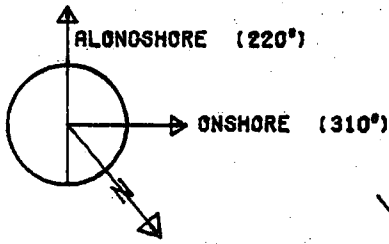

WINDSPEED<sup>2</sup>

0 40 M<sup>2</sup>/SEC<sup>2</sup>

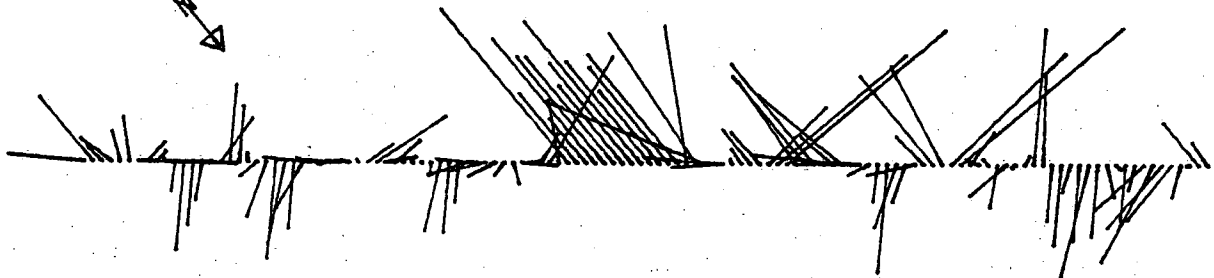

FILTERED CURRENT  
(0.0 TO 0.05 CPH)

DEPTH: 10 M

0 10 CM/SEC



DEPTH: 63 M

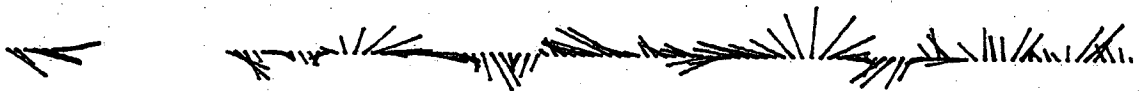

1' 2' 3' 4' 5' 6' 7' 8' 9' 10' 11' 12' 13' 14' 15' 16' 17' 18' 19' 20' 21' 22' 23' 24' 25' 26' 27' 28' 29' 30' 31'

MOORING: 35      DATE: DEC 1973  
 MONTHLY SUMMARY: WIND AND CURRENT\*

WIND  
 — 0-3 M/SEC  
 = 3-7 M/SEC  
 ≡ ≥ 7 M/SEC

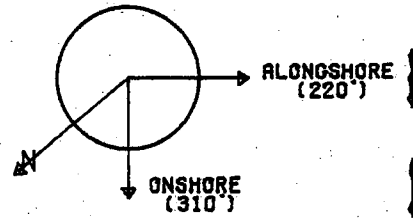
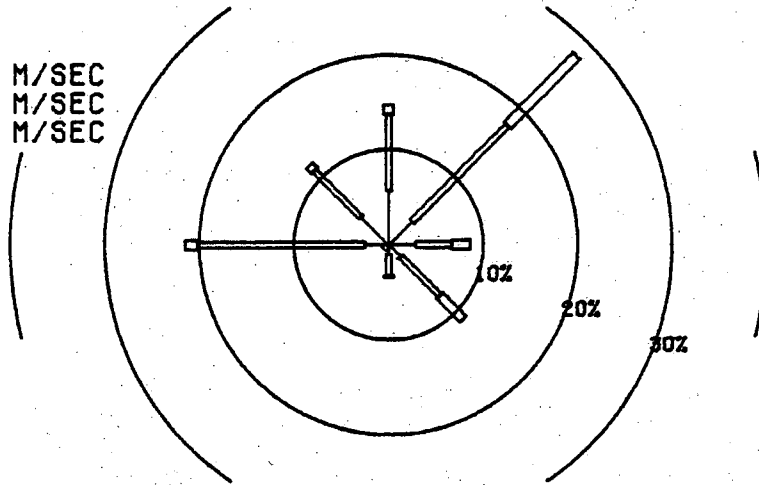

CURRENT  
 — 0-5 CM/SEC  
 = 5-15 CM/SEC  
 ≡ ≥ 15 CM/SEC

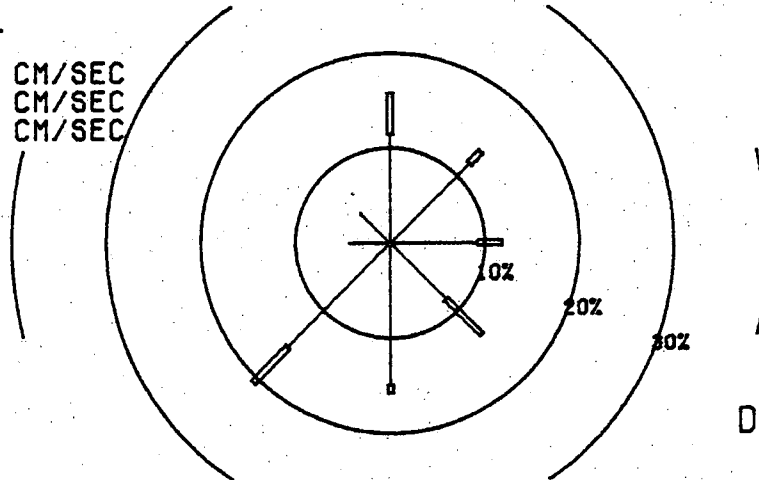

DEPTH: 10 M

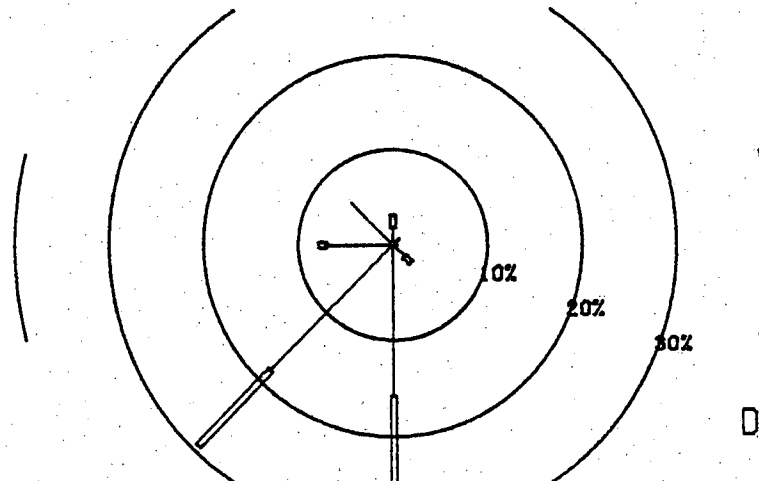

DEPTH: 64 M

\* DIRECTION TOWARDS



MOORING: 35

DATE: DEC 1973

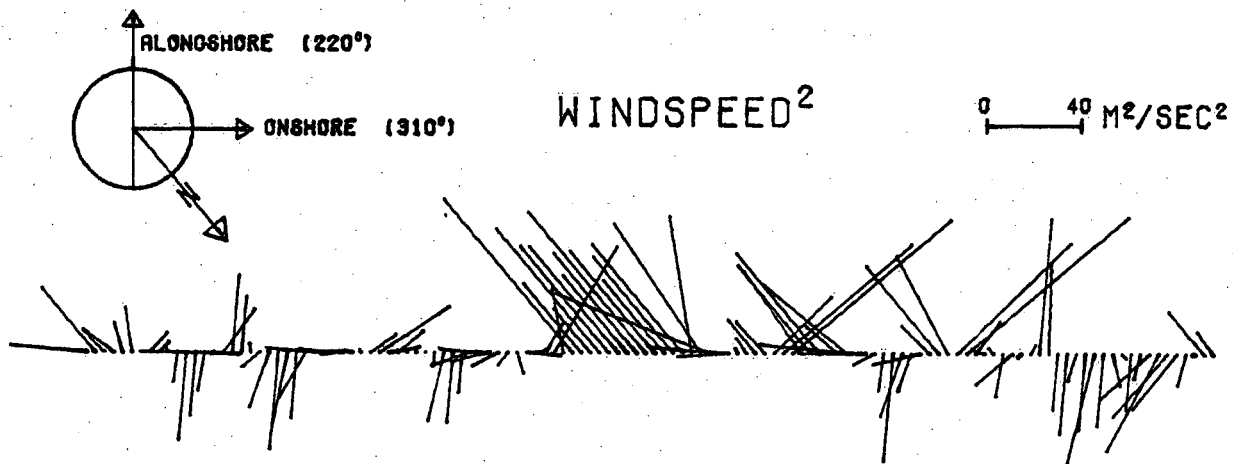

DEPTH: 10 M

FILTERED CURRENT  
(0.0 TO 0.05 CPH)

0 10 CM/SEC

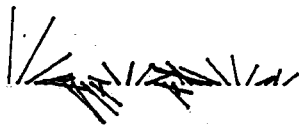

DEPTH: 64 M



1' 2' 3' 4' 5' 6' 7' 8' 9' 10' 11' 12' 13' 14' 15' 16' 17' 18' 19' 20' 21' 22' 23' 24' 25' 26' 27' 28' 29' 30' 31'

# METEOROLOGICAL DATA

MOORING: BURLINGTON DATE: JAN 1974

FILTERED WIND (0.0 TO 0.05 CPH)

0 10 M/SEC

N ↑

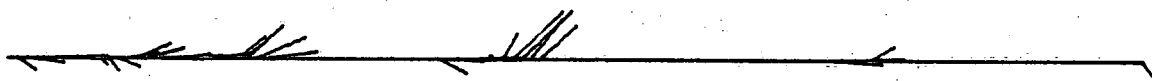

FILTERED WIND (0.0 TO 0.2 CPH) \*

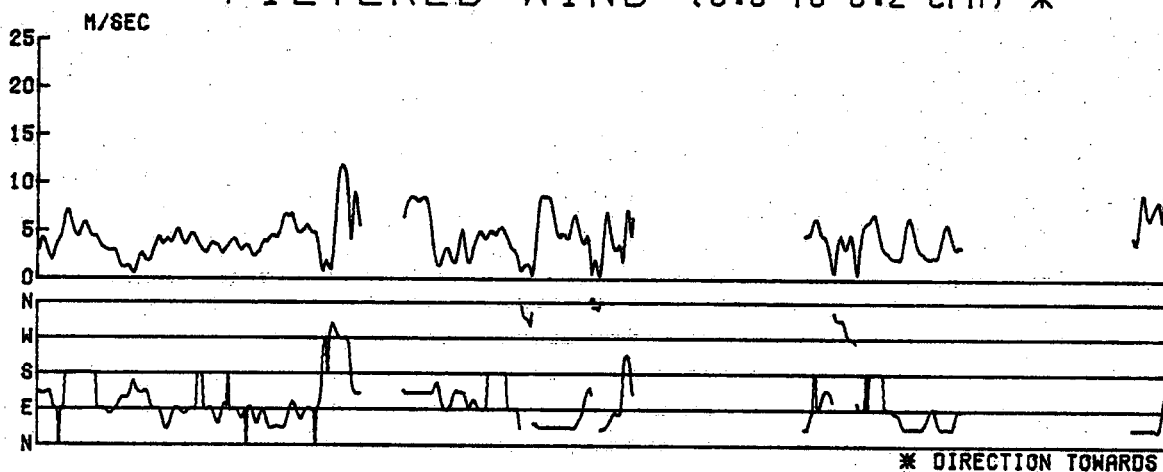

TEMPERATURE °C

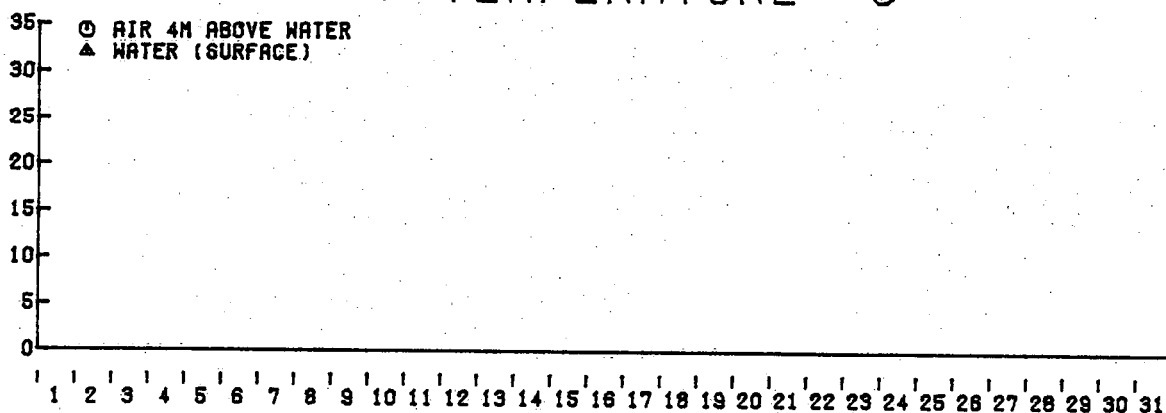

DAILY MAXIMUM AND MINIMUM AIR TEMPERATURE

DAY	TMAX	TMIN	DAY	TMAX	TMIN	DAY	TMAX	TMIN	DAY	TMAX	TMIN
1			9			17			25		
2			10			18			26		
3			11			19			27		
4			12			20			28		
5			13			21			29		
6			14			22			30		
7			15			23			31		
8			16			24					

MOORING: 30      DATE: JAN 1974  
 MONTHLY SUMMARY: WIND AND CURRENT\*

WIND  
 — 0-3 M/SEC  
 = 3-7 M/SEC  
 ≡ ≥ 7 M/SEC

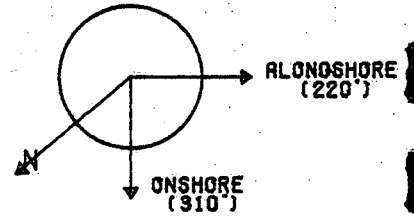
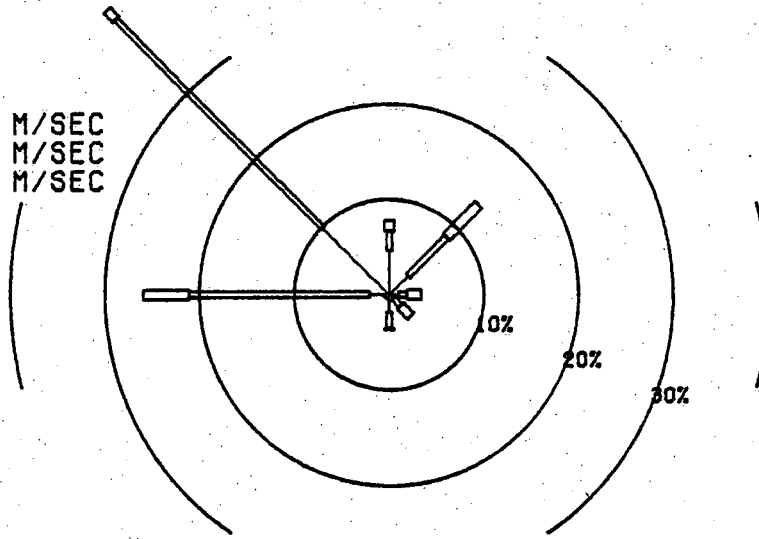

CURRENT  
 — 0-5 CM/SEC  
 = 5-15 CM/SEC  
 ≡ ≥ 15 CM/SEC

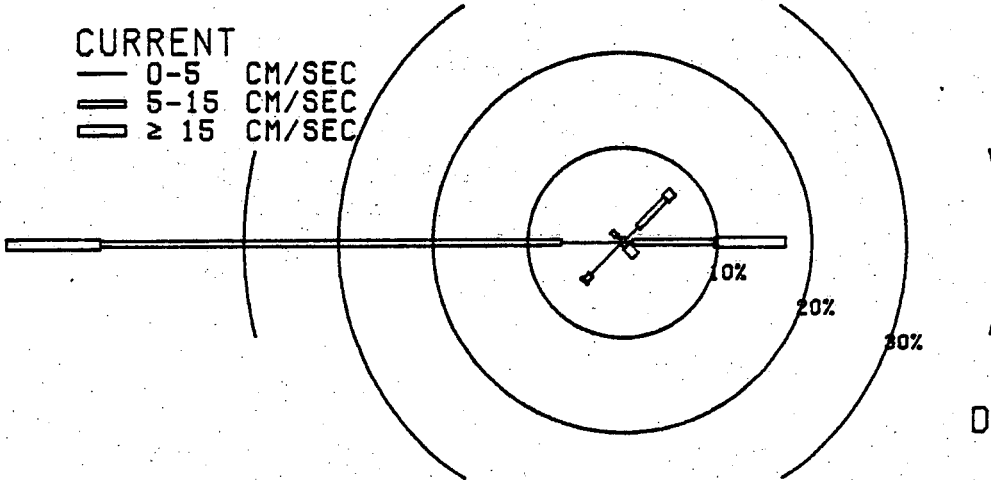

DEPTH: 10 M

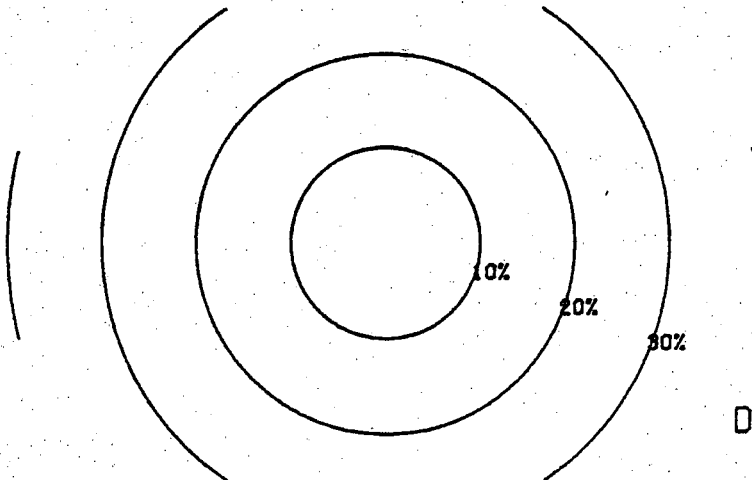

DEPTH: M

\* DIRECTION TOWARDS

MOORING : 30

DATE : JAN 1974

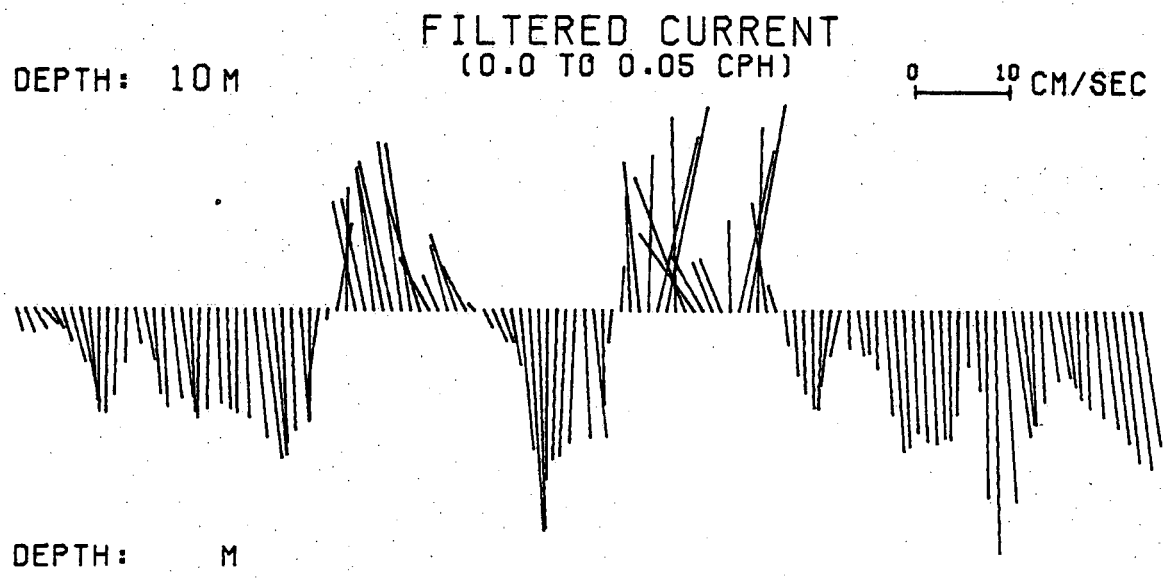
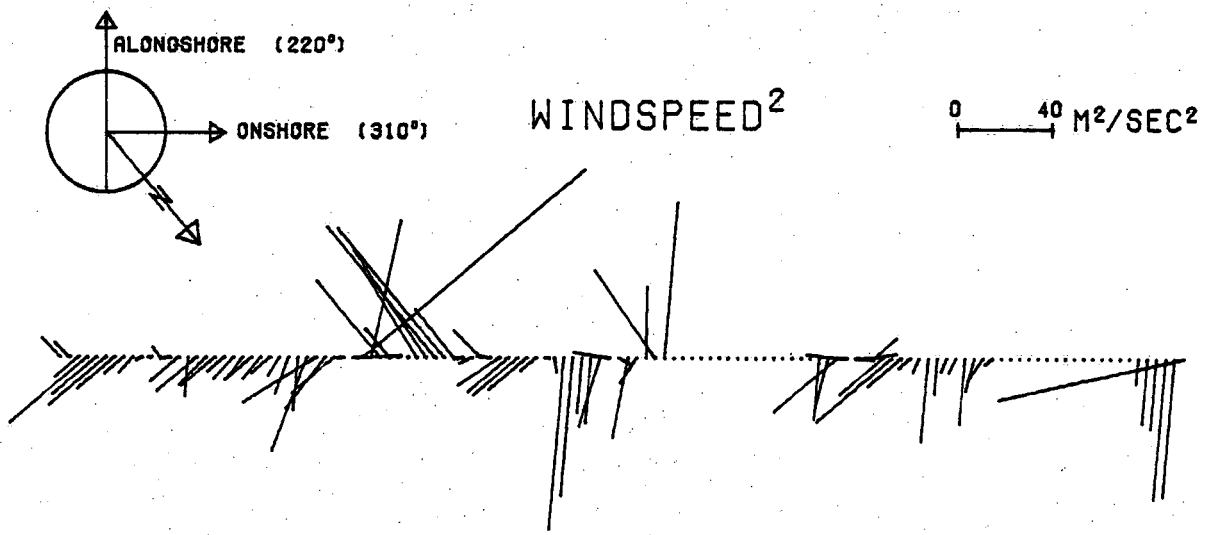

1 2 3 4 5 6 7 8 9 10 11 12 13 14 15 16 17 18 19 20 21 22 23 24 25 26 27 28 29 30 31

MOORING: 31      DATE: JAN 1974  
 MONTHLY SUMMARY: WIND AND CURRENT\*

WIND  
 — 0-3 M/SEC  
 = 3-7 M/SEC  
 ≡ ≥ 7 M/SEC

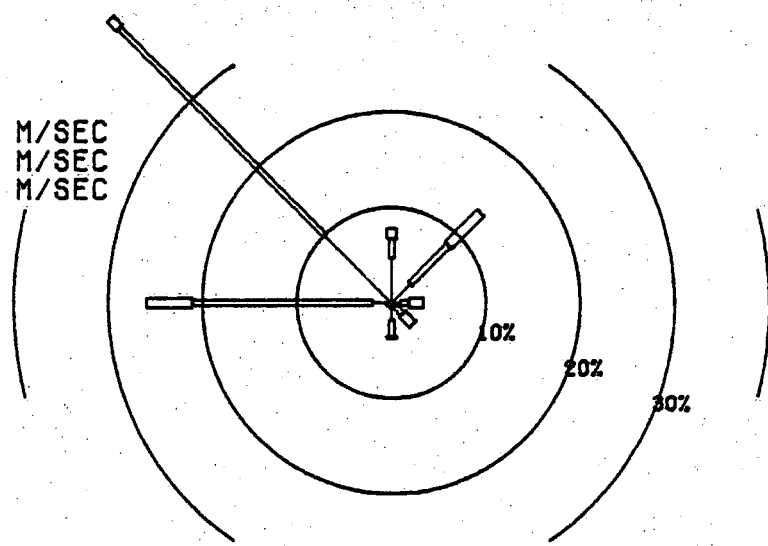

CURRENT  
 — 0-5 CM/SEC  
 = 5-15 CM/SEC  
 ≡ ≥ 15 CM/SEC

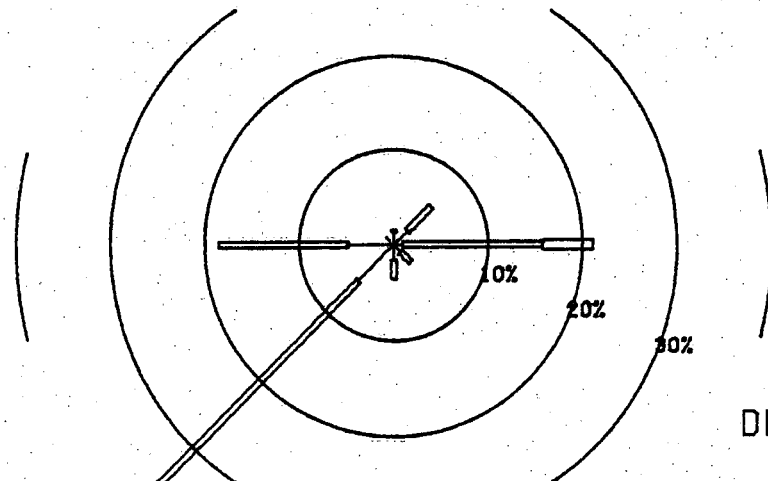
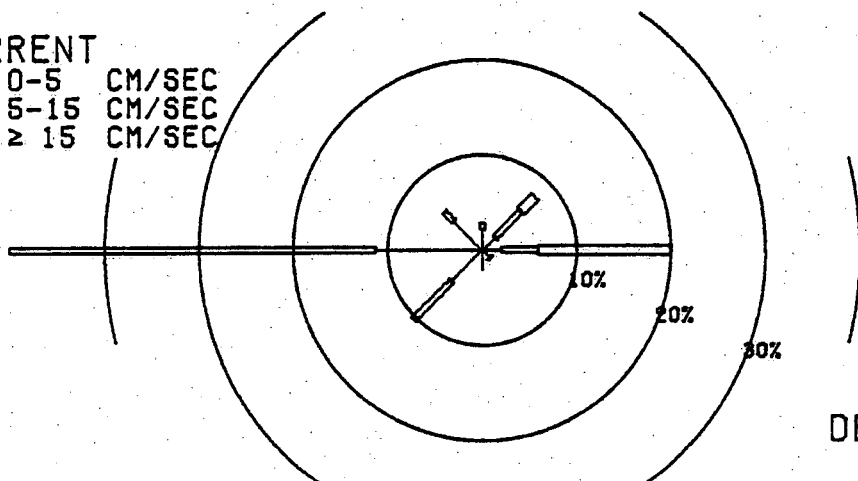

\* DIRECTION TOWARDS

MOORING : 31

DATE : JAN 1974

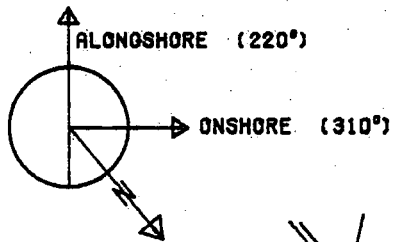

WINDSPEED<sup>2</sup>

0 40 M<sup>2</sup>/SEC<sup>2</sup>

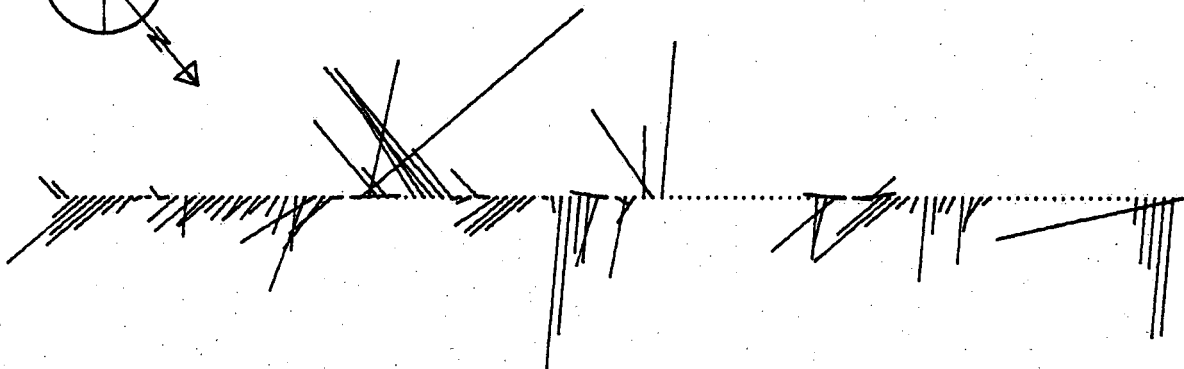

FILTERED CURRENT  
(0.0 TO 0.05 CPH)

DEPTH: 10 M

0 10 CM/SEC

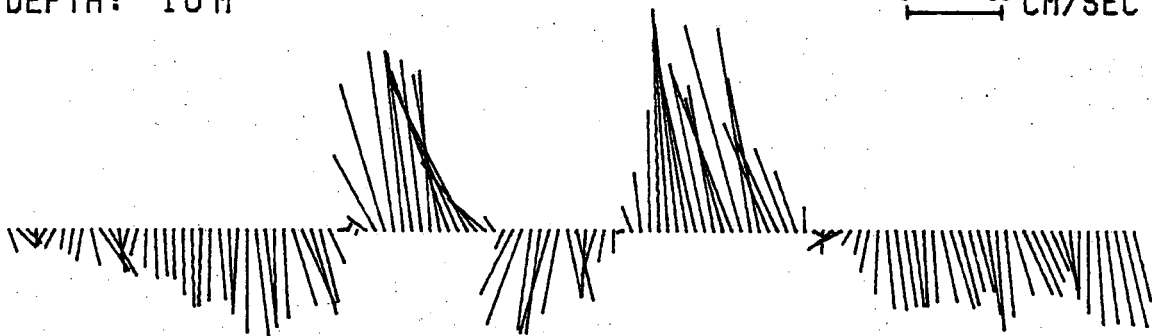

DEPTH: 38 M

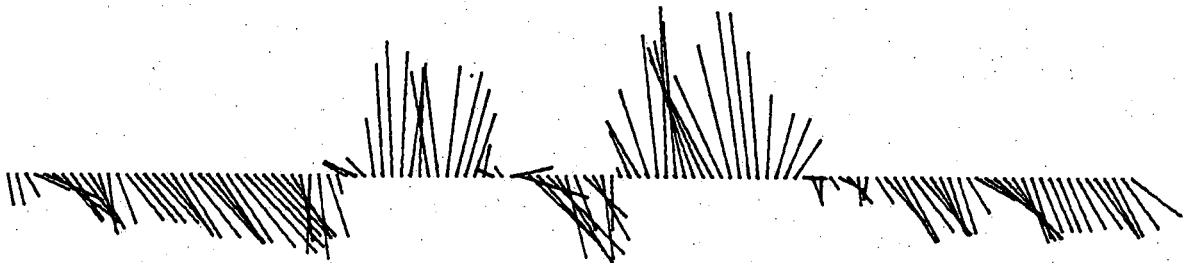

1 2 3 4 5 6 7 8 9 10 11 12 13 14 15 16 17 18 19 20 21 22 23 24 25 26 27 28 29 30 31

MOORING: 32      DATE: JAN 1974  
 MONTHLY SUMMARY: WIND AND CURRENT\*

WIND  
 — 0-3 M/SEC  
 = 3-7 M/SEC  
 ≡ ≥ 7 M/SEC

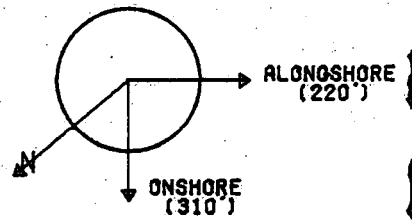
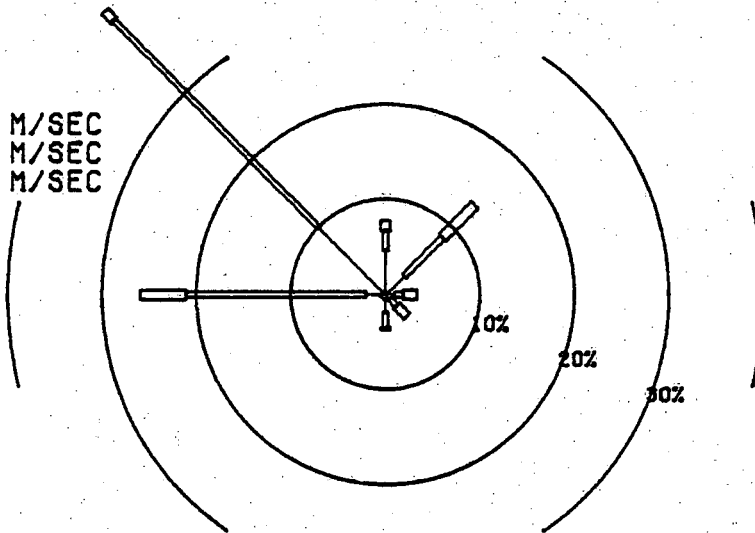

CURRENT  
 — 0-5 CM/SEC  
 = 5-15 CM/SEC  
 ≡ ≥ 15 CM/SEC

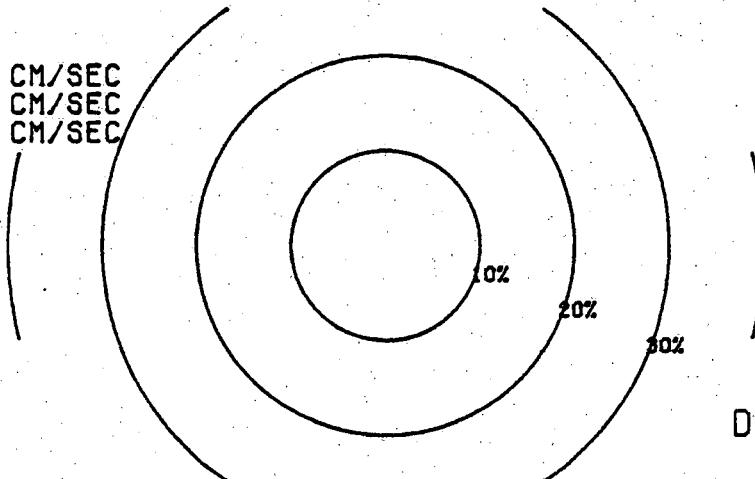

DEPTH: M

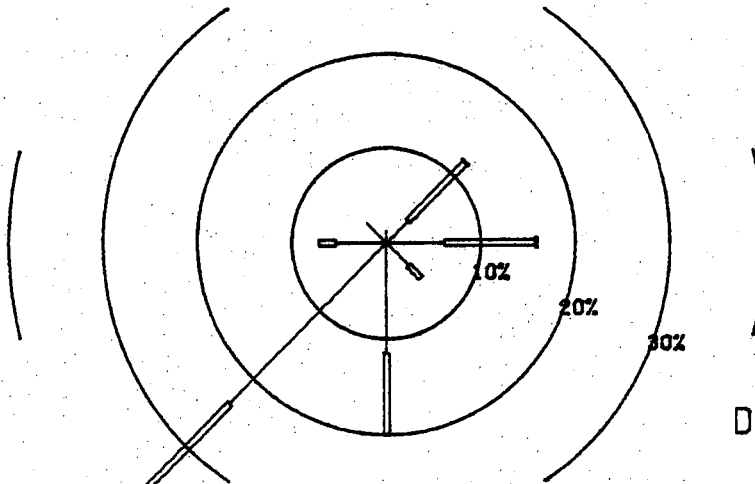

DEPTH: 51 M

\* DIRECTION TOWARDS

MOORING: 32

DATE: JAN 1974

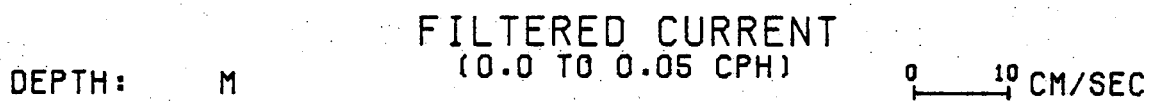
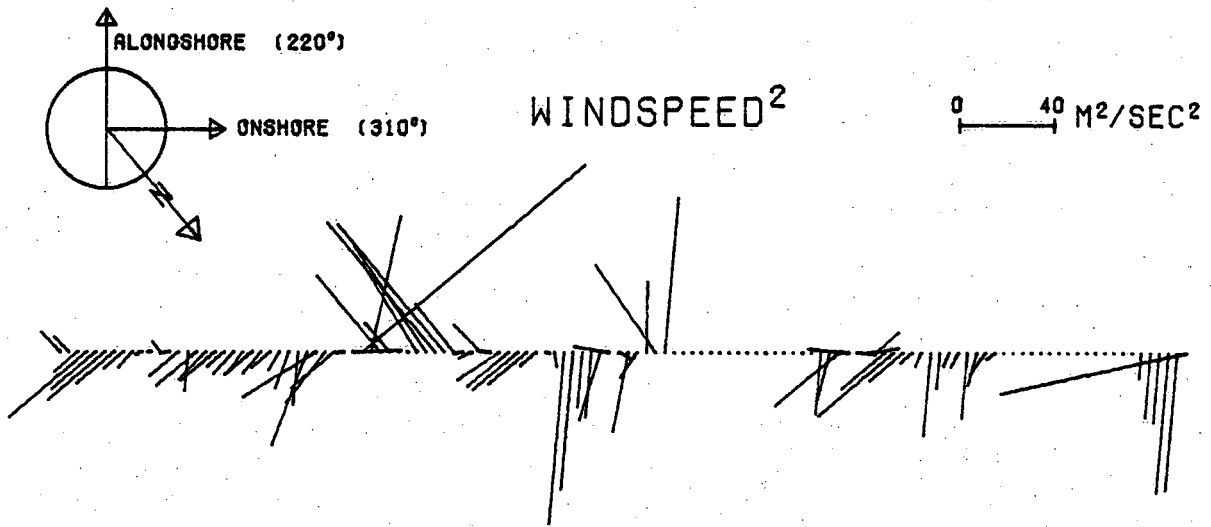

DEPTH: 51 M



1 2 3 4 5 6 7 8 9 10 11 12 13 14 15 16 17 18 19 20 21 22 23 24 25 26 27 28 29 30 31



MOORING: 33      DATE: JAN 1974  
 MONTHLY SUMMARY: WIND AND CURRENT\*

WIND  
 — 0-3 M/SEC  
 = 3-7 M/SEC  
 ≡ ≥ 7 M/SEC

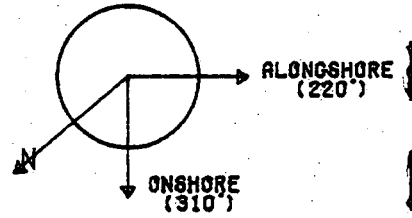
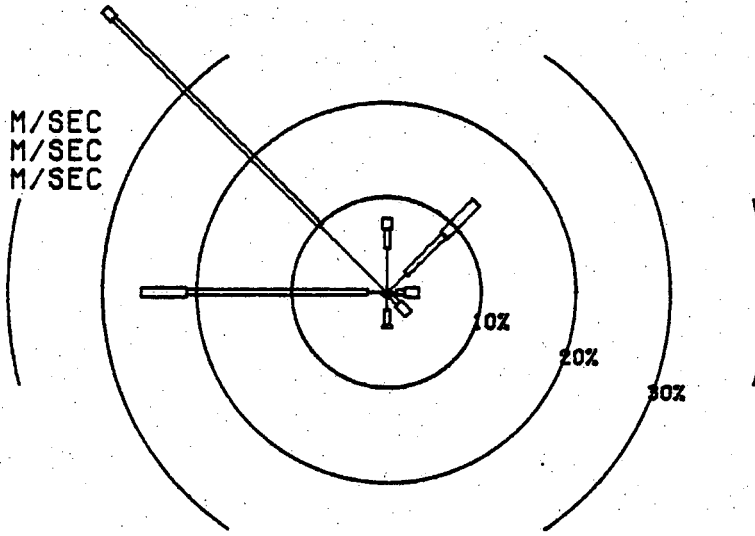

CURRENT  
 — 0-5 CM/SEC  
 = 5-15 CM/SEC  
 ≡ ≥ 15 CM/SEC

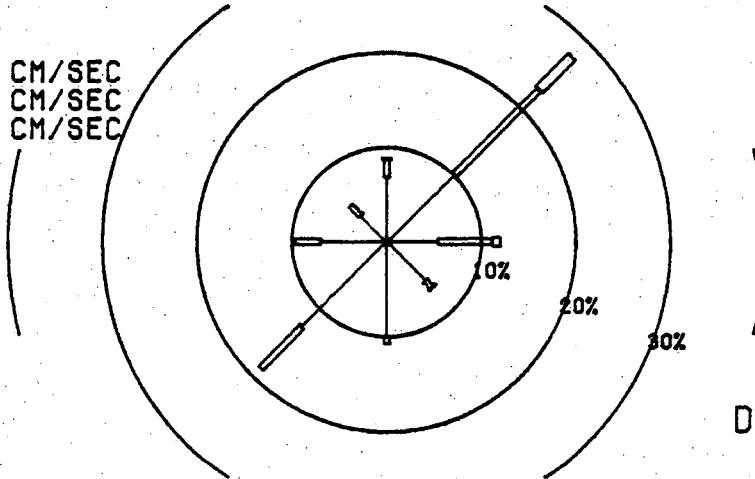

DEPTH: 10 M

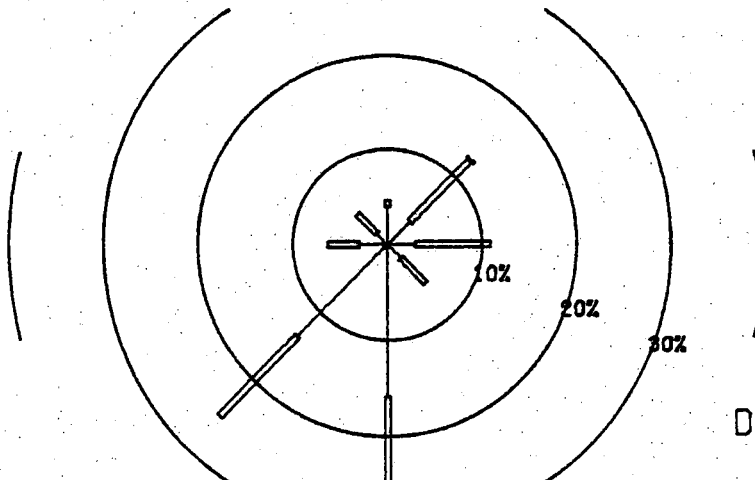

DEPTH: 61 M

\* DIRECTION TOWARDS

MOORING: 33

DATE: JAN 1974

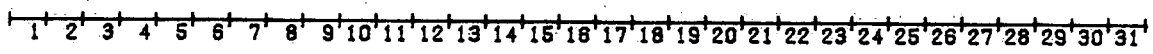
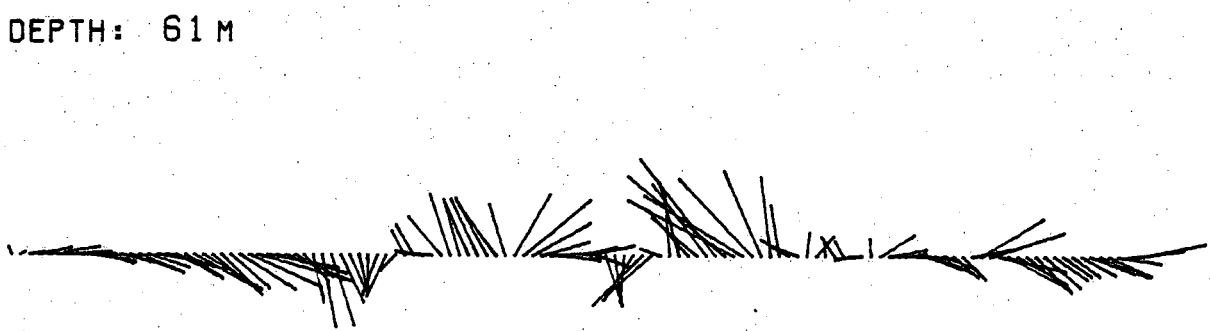
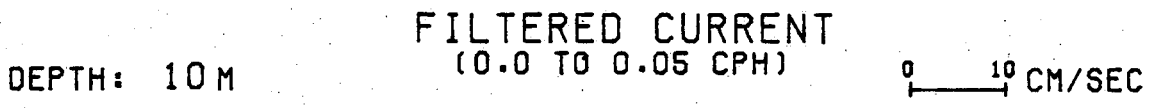
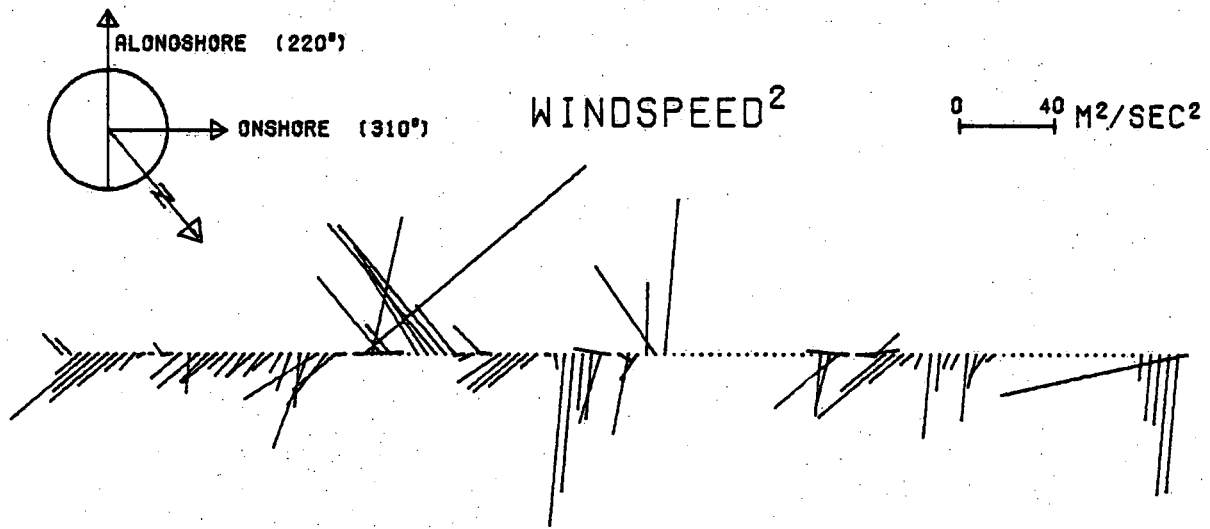

MOORING: 34      DATE: JAN 1974  
 MONTHLY SUMMARY: WIND AND CURRENT\*

WIND  
 — 0-3 M/SEC  
 = 3-7 M/SEC  
 ≡ ≥ 7 M/SEC

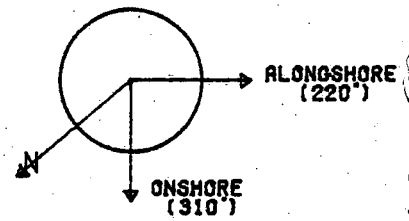
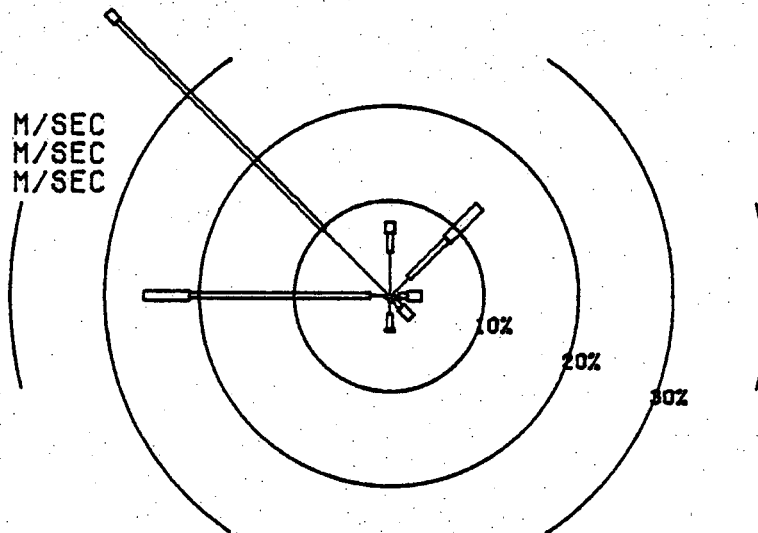

CURRENT  
 — 0-5 CM/SEC  
 = 5-15 CM/SEC  
 ≡ ≥ 15 CM/SEC

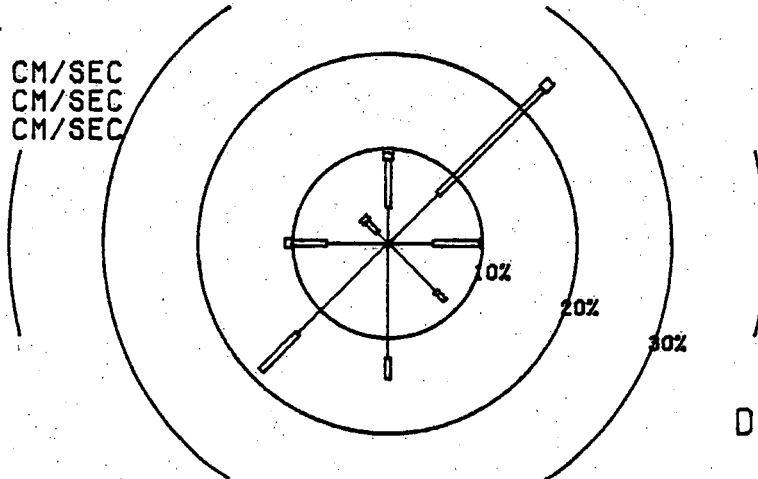

DEPTH: 10 M

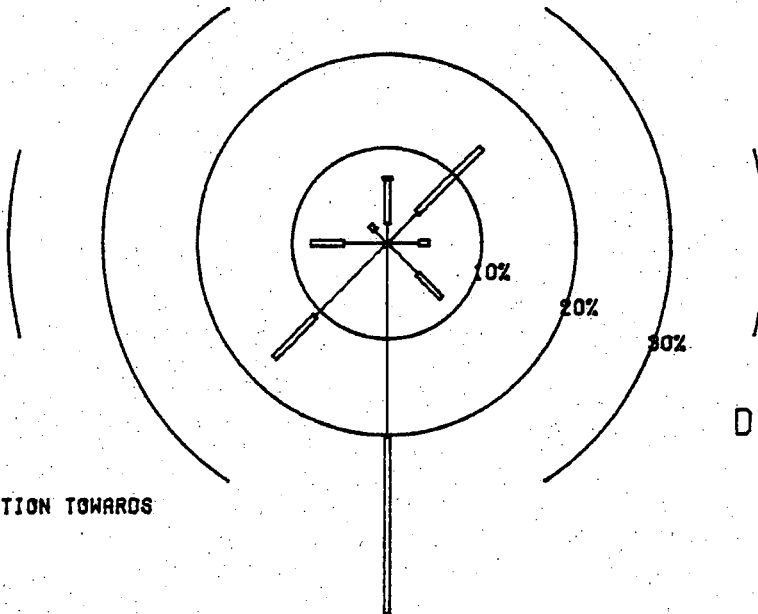

DEPTH: 63 M

\* DIRECTION TOWARDS

MOORING: 34

DATE: JAN 1974

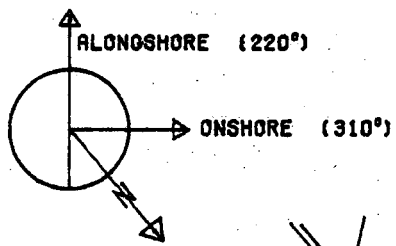

WINDSPEED<sup>2</sup>

0 40 M<sup>2</sup>/SEC<sup>2</sup>

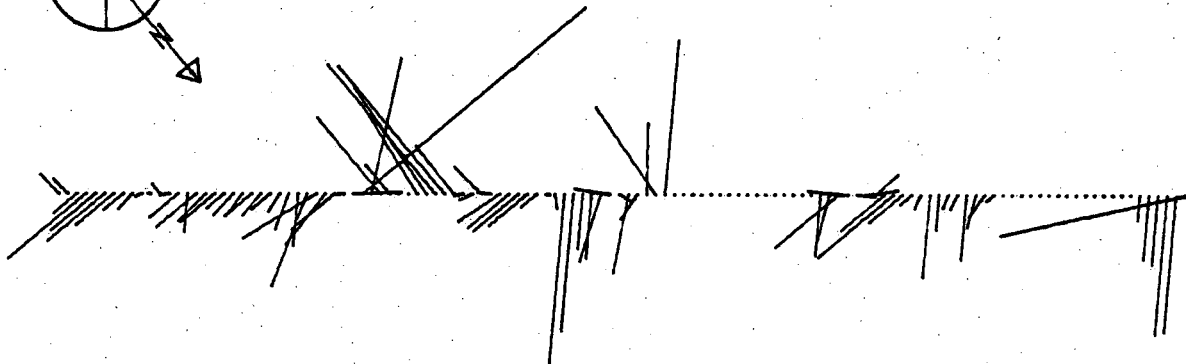

FILTERED CURRENT  
(0.0 TO 0.05 CPH)

DEPTH: 10 M

0 10 CM/SEC



DEPTH: 63 M



1' 2' 3' 4' 5' 6' 7' 8' 9' 10' 11' 12' 13' 14' 15' 16' 17' 18' 19' 20' 21' 22' 23' 24' 25' 26' 27' 28' 29' 30' 31'

# METEOROLOGICAL DATA

MOORING: BURLINGTON DATE: FEB 1974

## FILTERED WIND (0.0 TO 0.05 CPH)

0 10 M/SEC

N  
↑

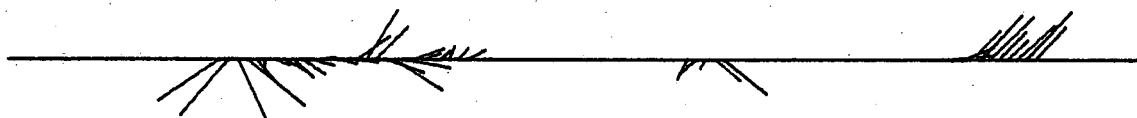

## FILTERED WIND (0.0 TO 0.2 CPH) \*

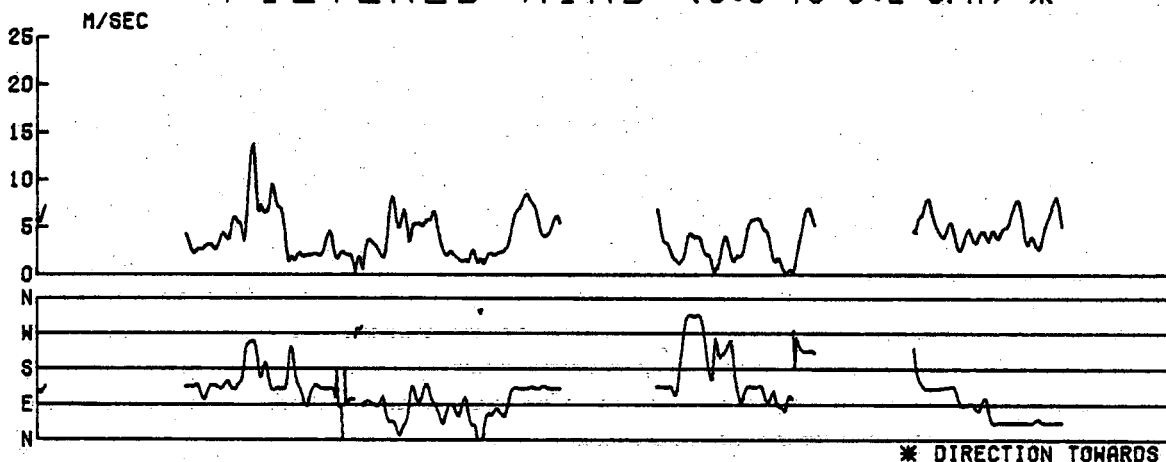

\* DIRECTION TOWARDS

## TEMPERATURE °C

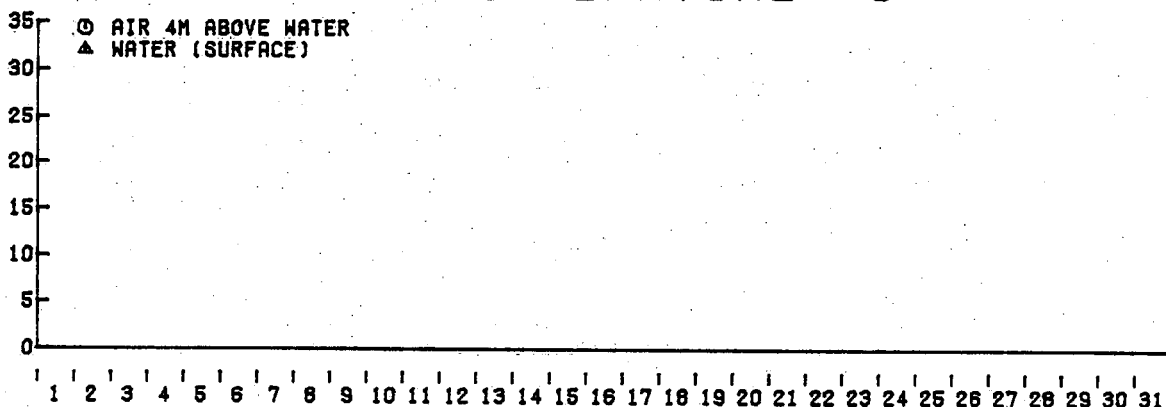

## DAILY MAXIMUM AND MINIMUM AIR TEMPERATURE

DAY	TMAX	TMIN	DAY	TMAX	TMIN	DAY	TMAX	TMIN	DAY	TMAX	TMIN
1			9			17			25		
2			10			18			26		
3			11			19			27		
4			12			20			28		
5			13			21			29		
6			14			22			30		
7			15			23			31		
8			16			24					

MOORING: 30      DATE: FEB 1974  
 MONTHLY SUMMARY: WIND AND CURRENT\*

WIND  
 — 0-3 M/SEC  
 = 3-7 M/SEC  
 ≡ ≥ 7 M/SEC

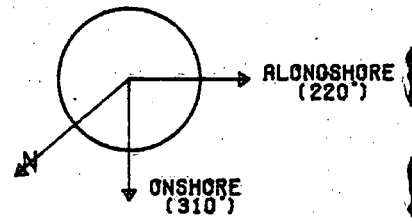
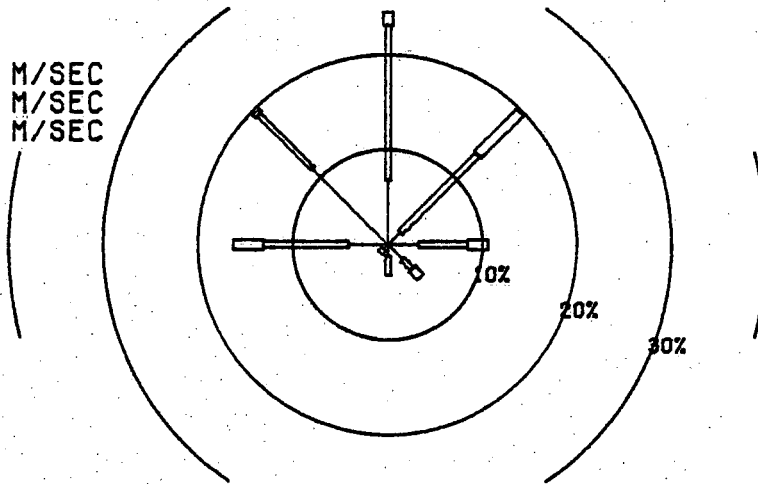

CURRENT  
 — 0-5 CM/SEC  
 = 5-15 CM/SEC  
 ≡ ≥ 15 CM/SEC

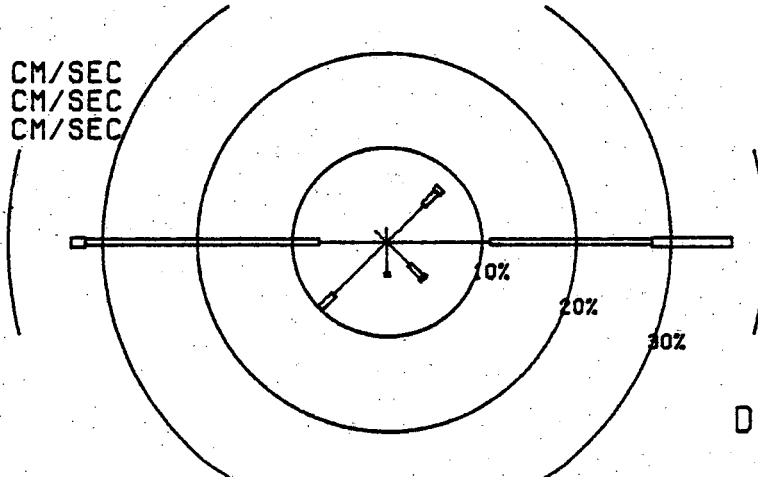

DEPTH: 10 M

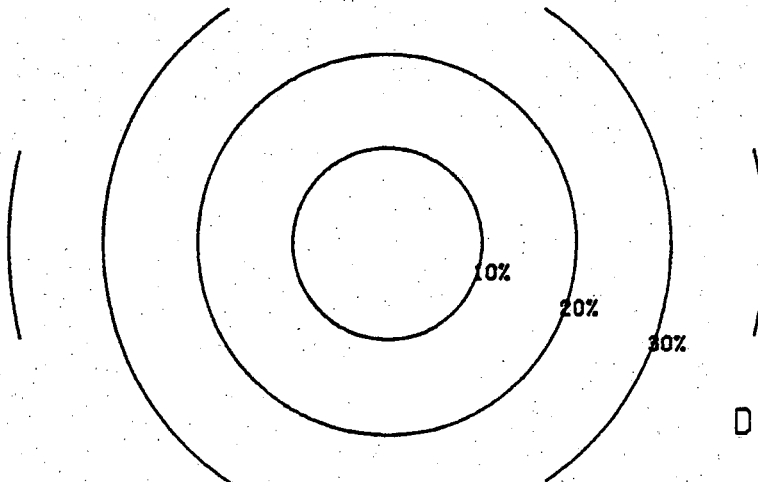

DEPTH: M

\* DIRECTION TOWARDS

MOORING : 30

DATE : FEB 1974

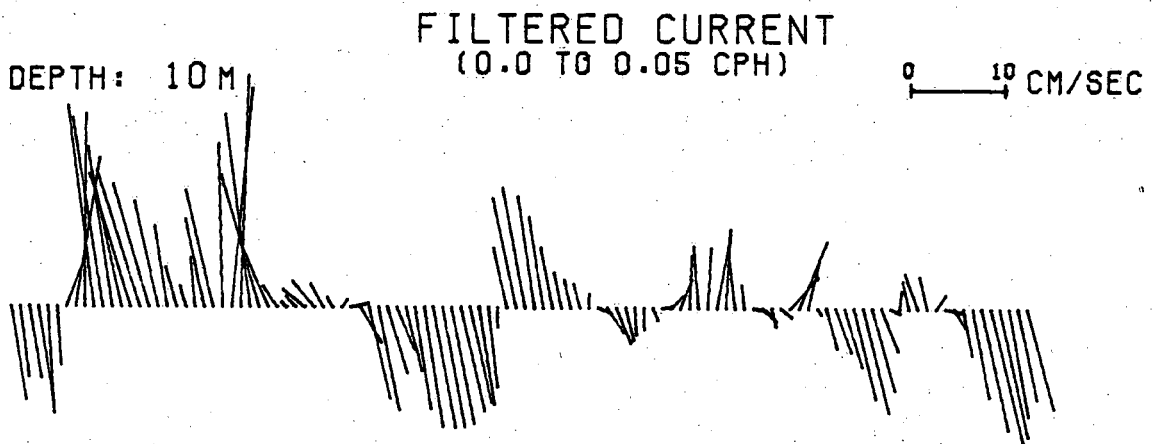
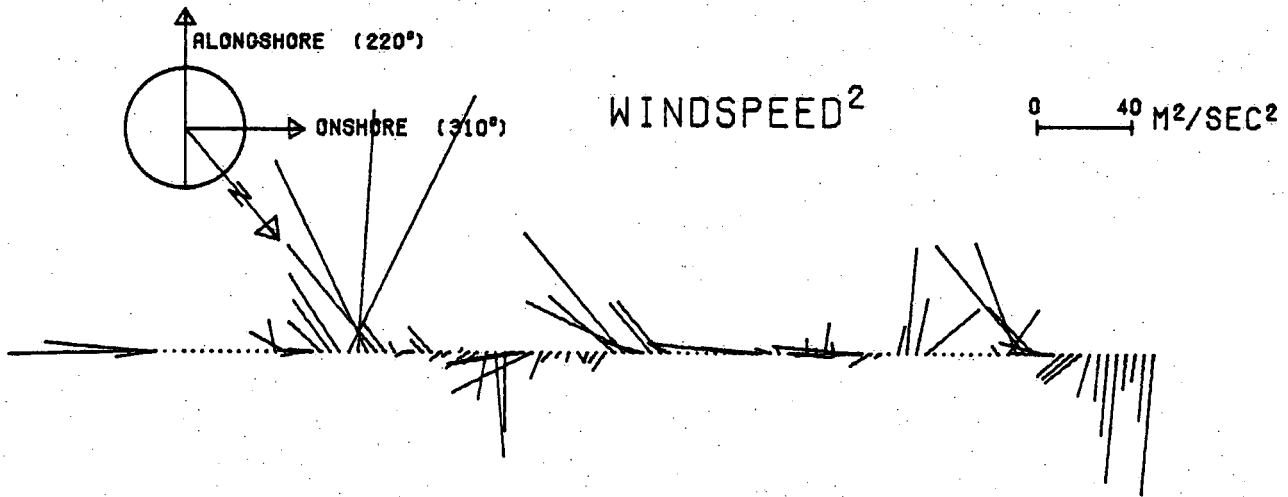

DEPTH: M

1 2 3 4 5 6 7 8 9 10 11 12 13 14 15 16 17 18 19 20 21 22 23 24 25 26 27 28 29 30 31

MOORING: 31      DATE: FEB 1974  
 MONTHLY SUMMARY: WIND AND CURRENT\*

WIND  
 — 0-3 M/SEC  
 = 3-7 M/SEC  
 ≡ ≥ 7 M/SEC

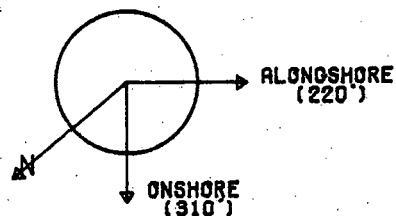
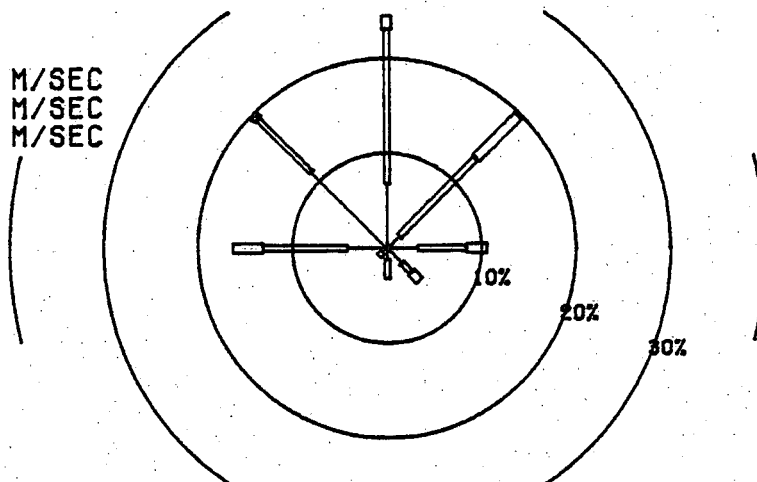

CURRENT  
 — 0-5 CM/SEC  
 = 5-15 CM/SEC  
 ≡ ≥ 15 CM/SEC

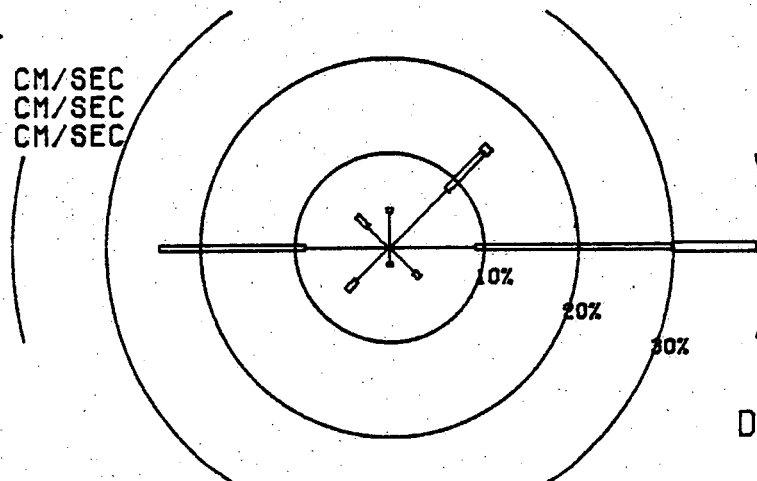

DEPTH: 10 M

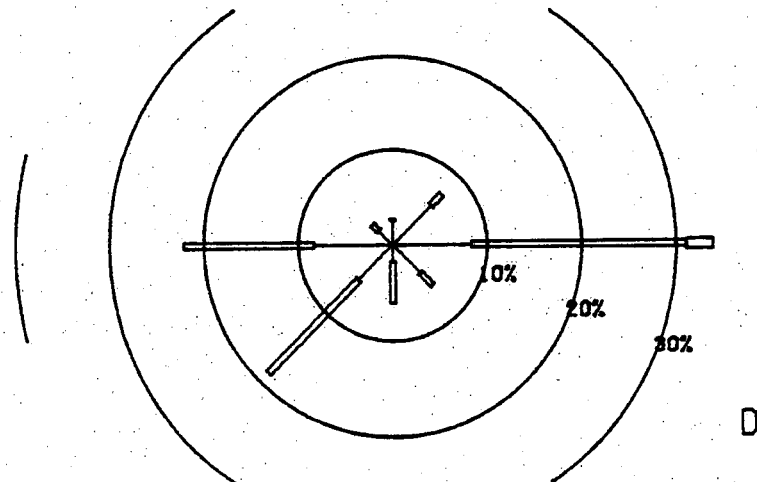

DEPTH: 38 M

\* DIRECTION TOWARDS



MOORING: 31

DATE: FEB 1974

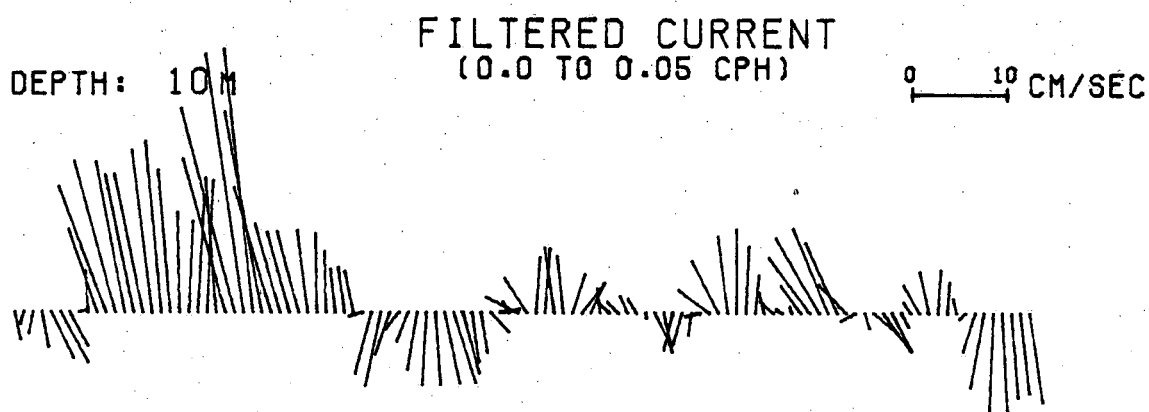
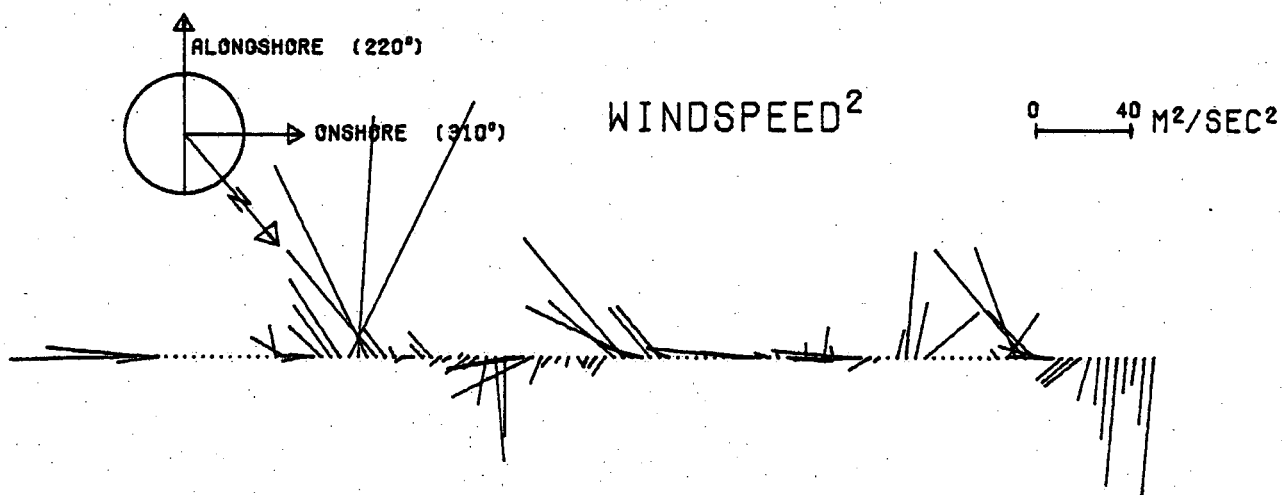

1 2 3 4 5 6 7 8 9 10 11 12 13 14 15 16 17 18 19 20 21 22 23 24 25 26 27 28 29 30 31

MOORING: 32      DATE: FEB 1974  
 MONTHLY SUMMARY: WIND AND CURRENT\*

WIND  
 — 0-3 M/SEC  
 = 3-7 M/SEC  
 = 7 M/SEC

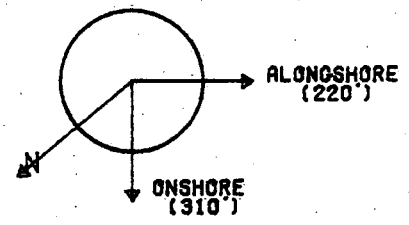
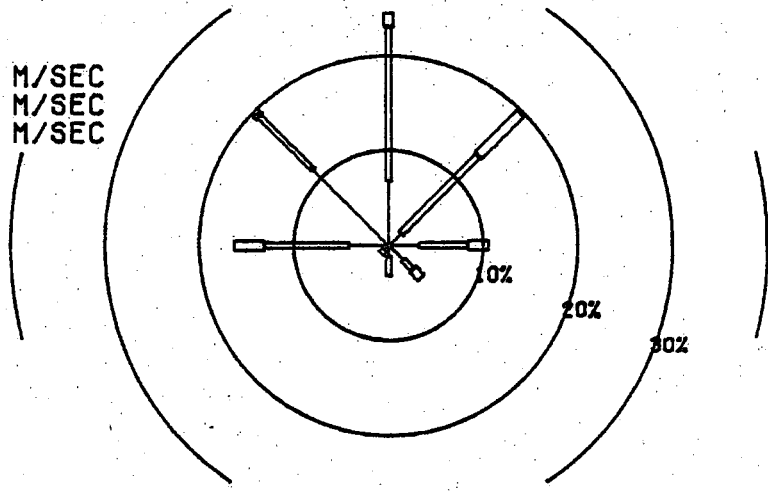

CURRENT  
 — 0-5 CM/SEC  
 = 5-15 CM/SEC  
 = 15 CM/SEC

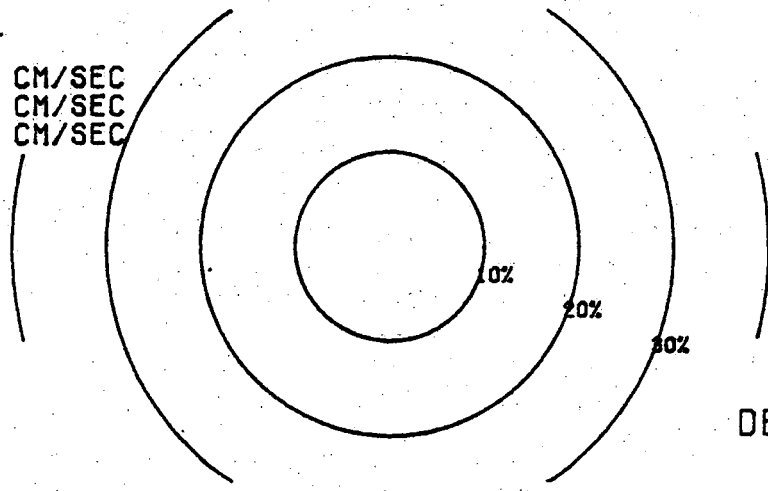

DEPTH: M

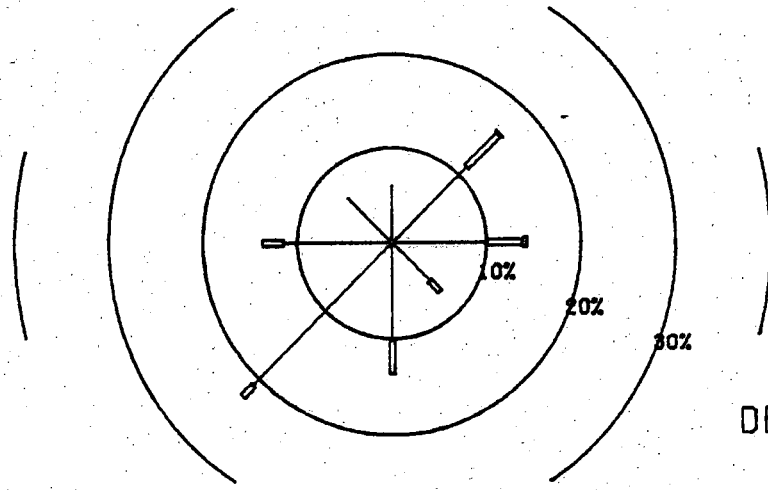

DEPTH: 51 M

\* DIRECTION TOWARDS

MOORING: 32

DATE: FEB 1974

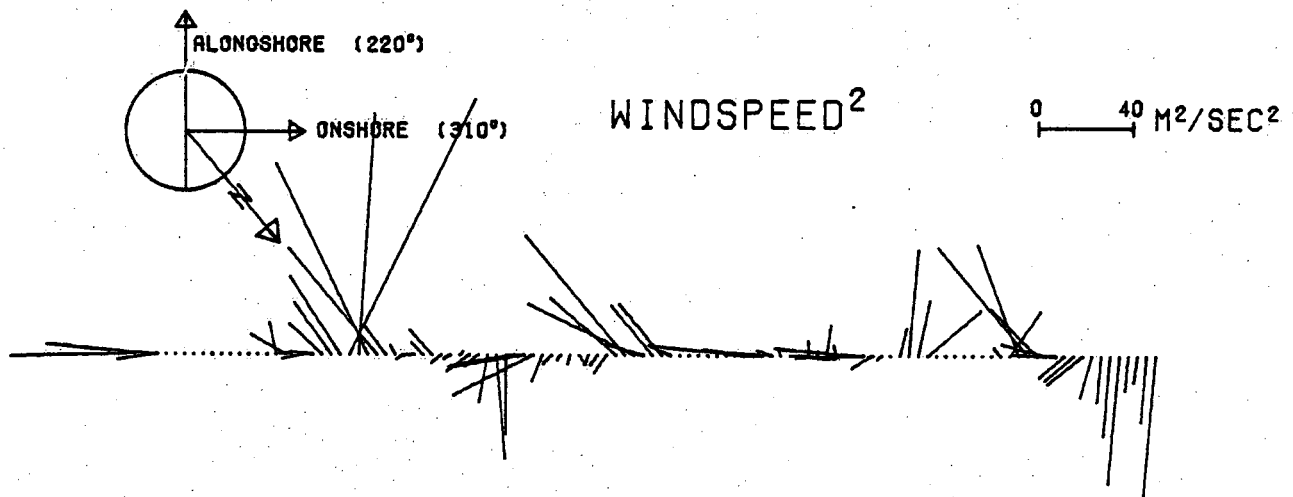

DEPTH: M

FILTERED CURRENT  
(0.0 TO 0.05 CPH)

0 10 CM/SEC

DEPTH: 51 M

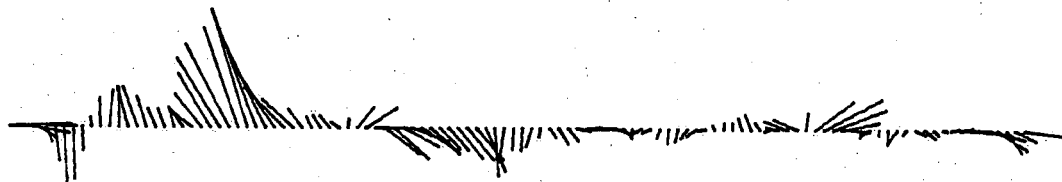

1 2 3 4 5 6 7 8 9 10 11 12 13 14 15 16 17 18 19 20 21 22 23 24 25 26 27 28 29 30 31

MOORING: 33      DATE: FEB 1974  
 MONTHLY SUMMARY: WIND AND CURRENT\*

WIND  
 — 0-3 M/SEC  
 = 3-7 M/SEC  
 ≡ ≥ 7 M/SEC

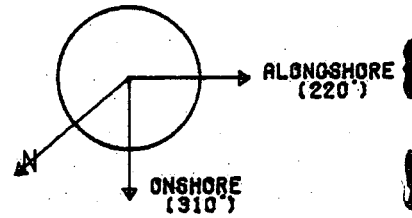
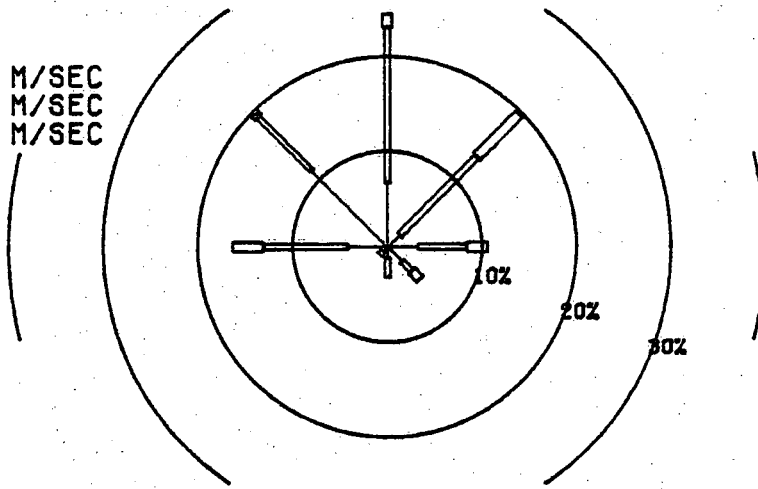

CURRENT  
 — 0-5 CM/SEC  
 = 5-15 CM/SEC  
 ≡ ≥ 15 CM/SEC

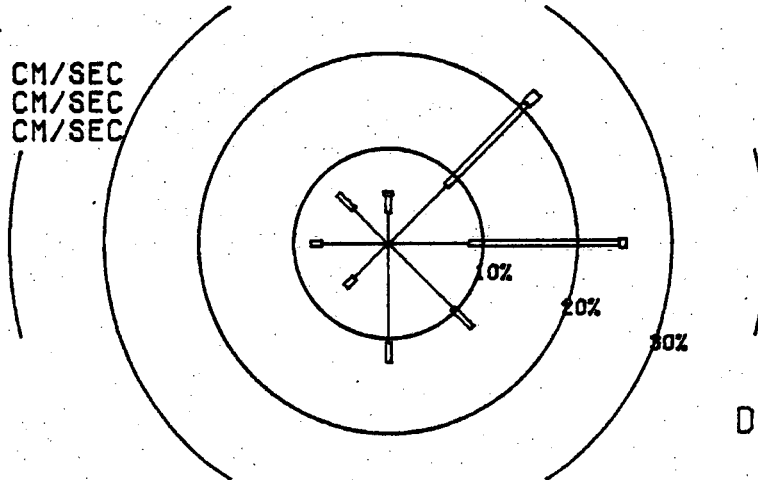

DEPTH: 10 M

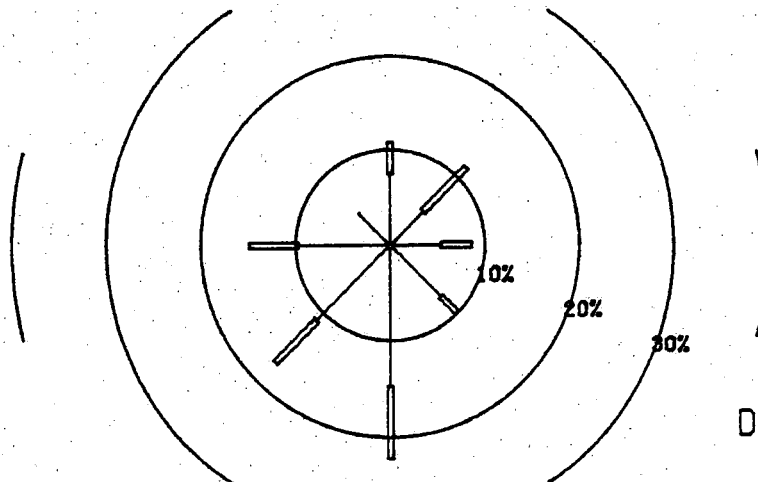

DEPTH: 61 M

\* DIRECTION TOWARDS

MOORING : 33

DATE : FEB 1974

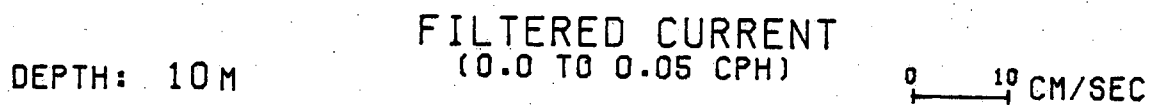
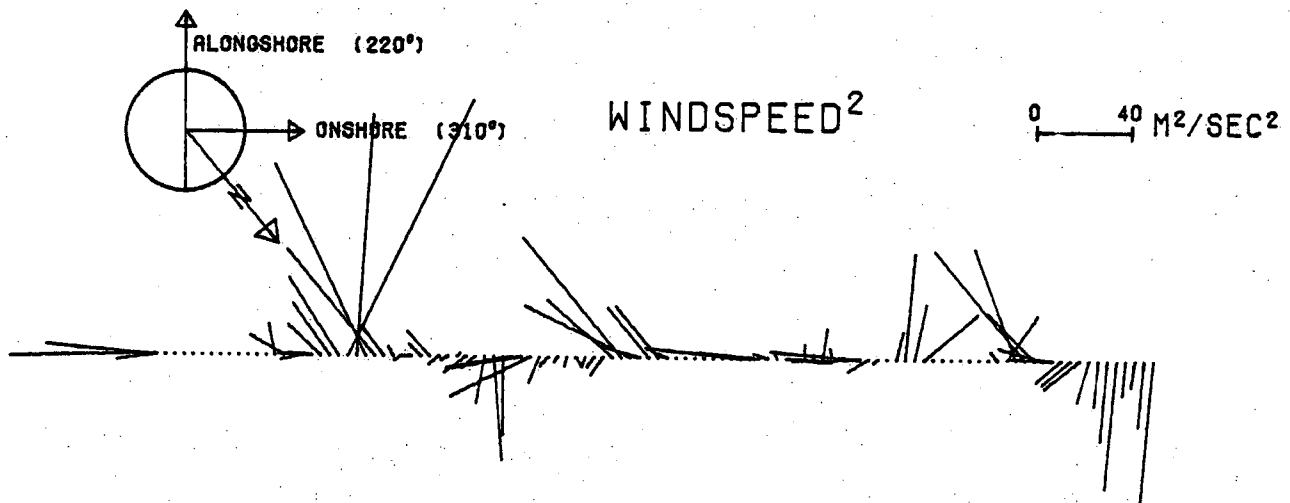

DEPTH: 61 M

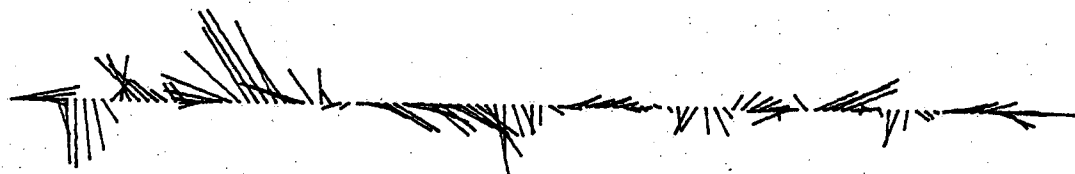

1 2 3 4 5 6 7 8 9 10 11 12 13 14 15 16 17 18 19 20 21 22 23 24 25 26 27 28 29 30 31

MOORING: 34      DATE: FEB 1974  
 MONTHLY SUMMARY: WIND AND CURRENT\*

WIND  
 — 0-3 M/SEC  
 = 3-7 M/SEC  
 ≡ ≥ 7 M/SEC

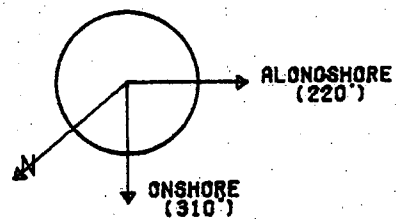
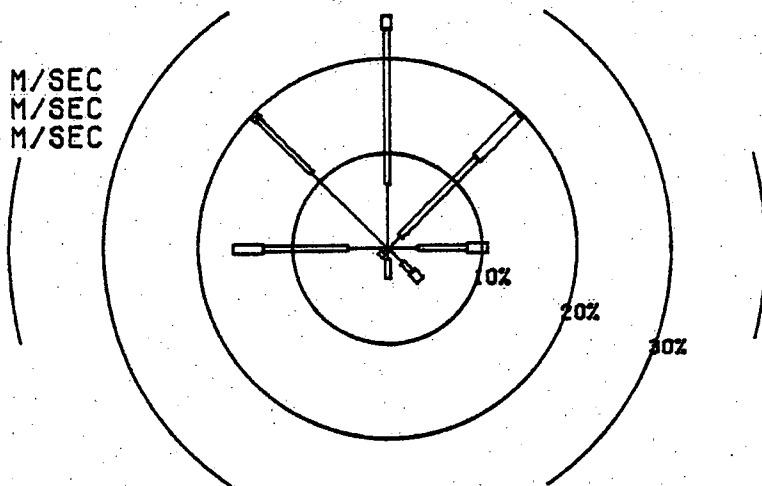

CURRENT  
 — 0-5 CM/SEC  
 = 5-15 CM/SEC  
 ≡ ≥ 15 CM/SEC

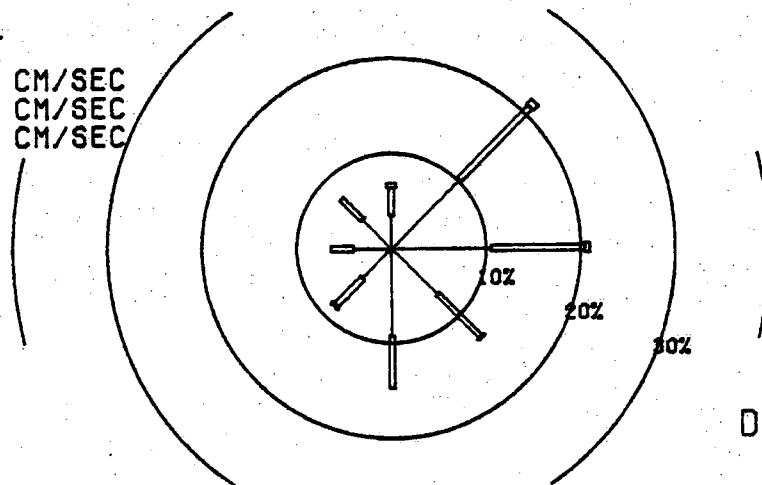

DEPTH: 10 M

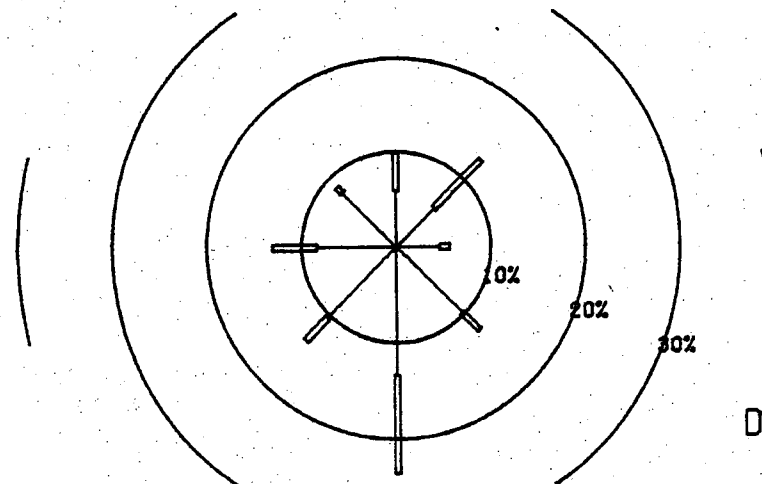

DEPTH: 63 M

\* DIRECTION TOWARDS

MOORING: 34

DATE: FEB 1974

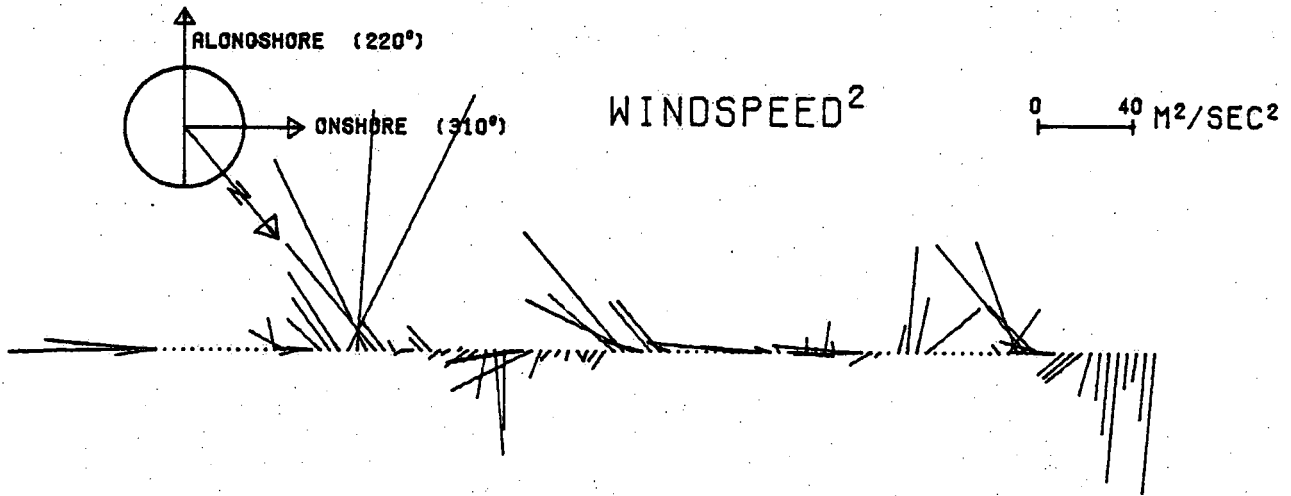

DEPTH: 10 M

FILTERED CURRENT  
(0.0 TO 0.05 CPH)

0 10 CM/SEC

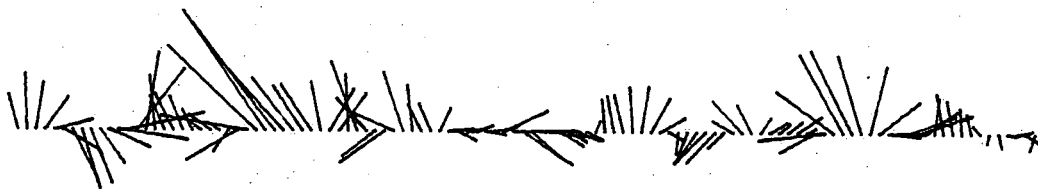

DEPTH: 63 M

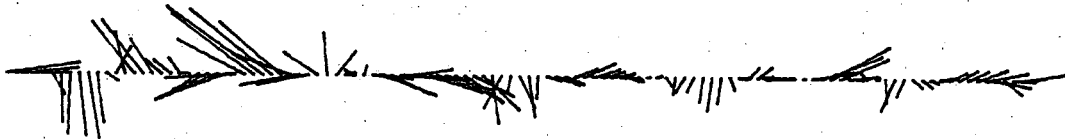

1 2 3 4 5 6 7 8 9 10 11 12 13 14 15 16 17 18 19 20 21 22 23 24 25 26 27 28 29 30 31

# METEOROLOGICAL DATA

MOORING: BURLINGTON DATE: MAR 1974

FILTERED WIND (0.0 TO 0.05 CPH)

0 — 10 M/SEC

N ↑



FILTERED WIND (0.0 TO 0.2 CPH) \*

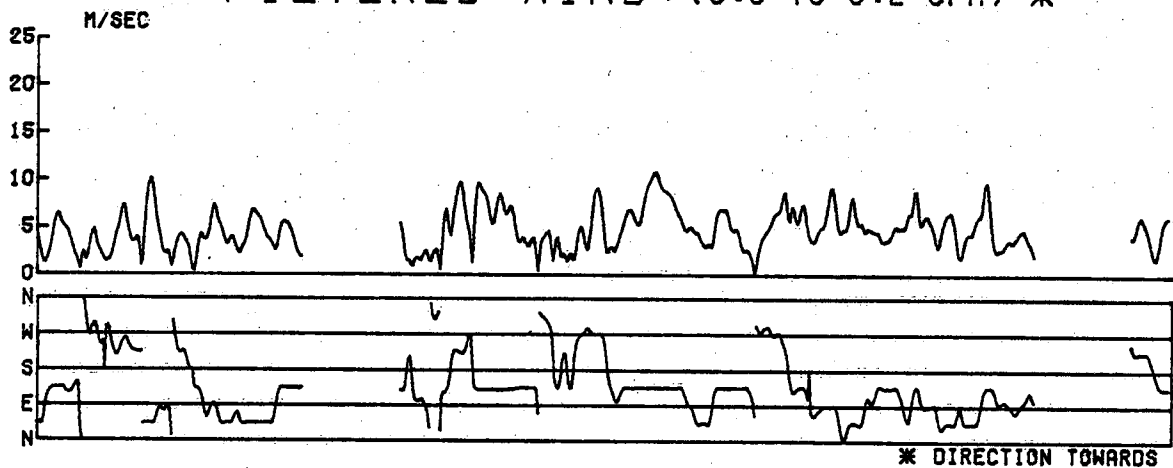

TEMPERATURE °C

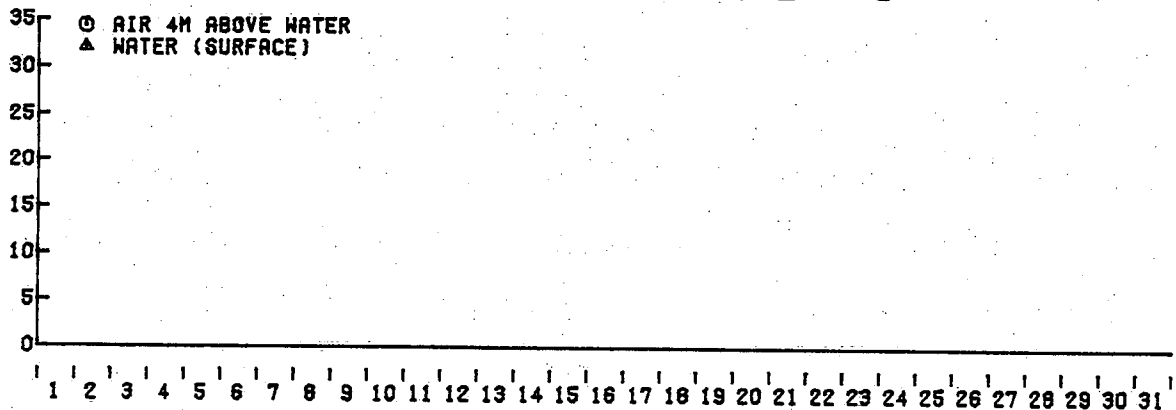

DAILY MAXIMUM AND MINIMUM AIR TEMPERATURE

DAY	TMAX	TMIN	DAY	TMAX	TMIN	DAY	TMAX	TMIN	DAY	TMAX	TMIN
1			9			17			25		
2			10			18			26		
3			11			19			27		
4			12			20			28		
5			13			21			29		
6			14			22			30		
7			15			23			31		
8			16			24					



MOORING: 30      DATE: MAR 1974  
 MONTHLY SUMMARY: WIND AND CURRENT\*

WIND  
 — 0-3 M/SEC  
 = 3-7 M/SEC  
 ≡ ≥ 7 M/SEC

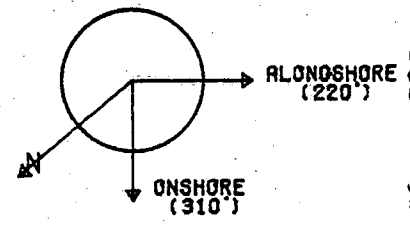
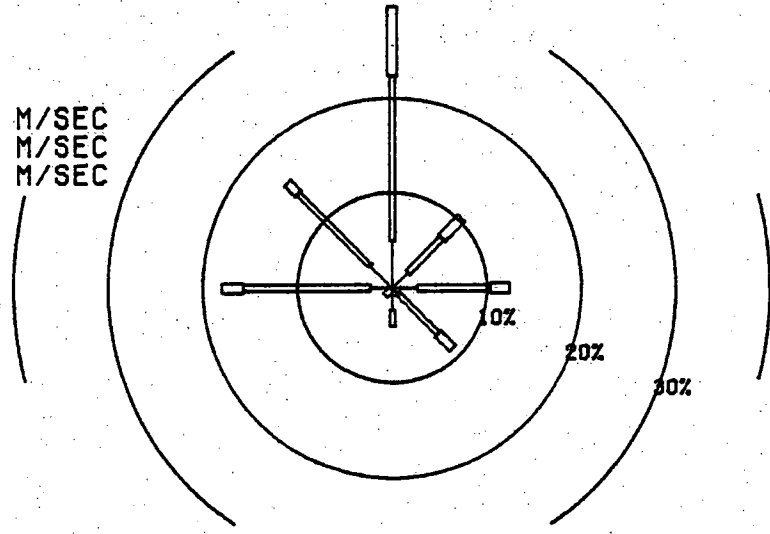

CURRENT  
 — 0-5 CM/SEC  
 = 5-15 CM/SEC  
 ≡ ≥ 15 CM/SEC

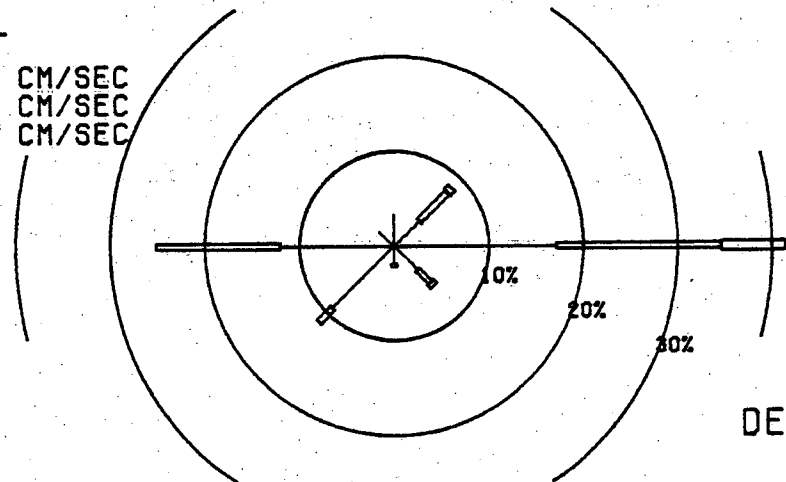

DEPTH: 10 M

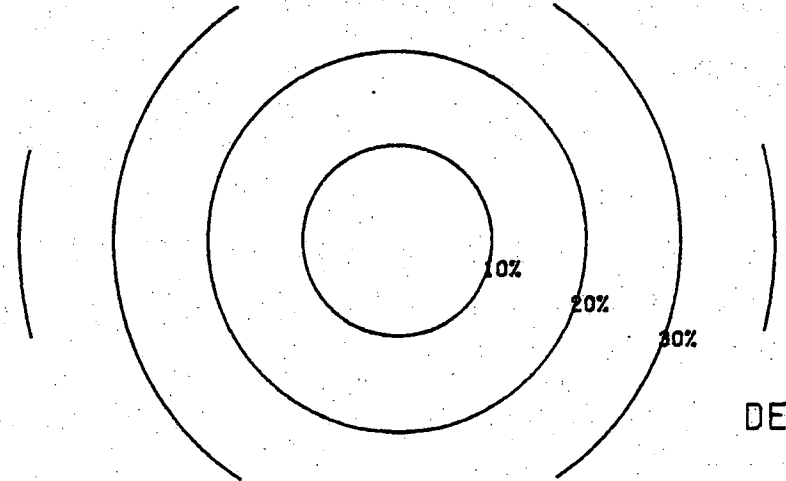

DEPTH: M

\* DIRECTION TOWARDS

MOORING : 30

DATE : MAR 1974

ALONGSHORE (220°)

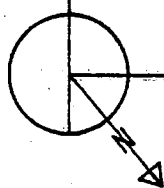

ONSHORE (310°)

WINDSPEED<sup>2</sup>

0 40 M<sup>2</sup>/SEC<sup>2</sup>

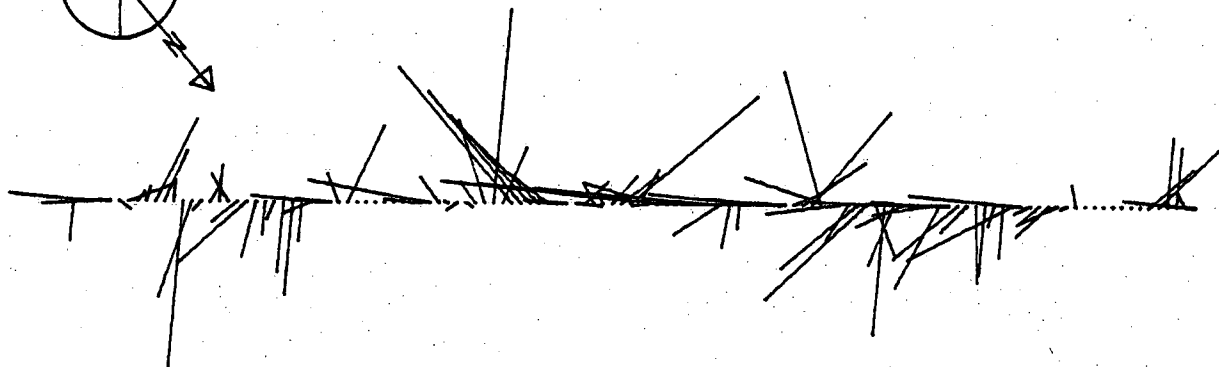

DEPTH: 10 M

FILTERED CURRENT  
(0.0 TO 0.05 CPH)

0 10 CM/SEC

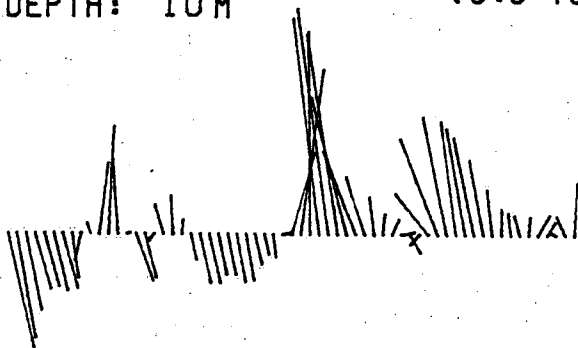

DEPTH: M

1 2 3 4 5 6 7 8 9 10 11 12 13 14 15 16 17 18 19 20 21 22 23 24 25 26 27 28 29 30 31

MOORING: 31      DATE: MAR 1974  
 MONTHLY SUMMARY: WIND AND CURRENT\*

WIND  
 — 0-3 M/SEC  
 = 3-7 M/SEC  
 = 7 M/SEC

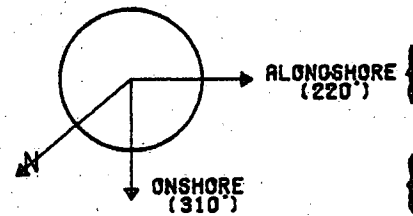
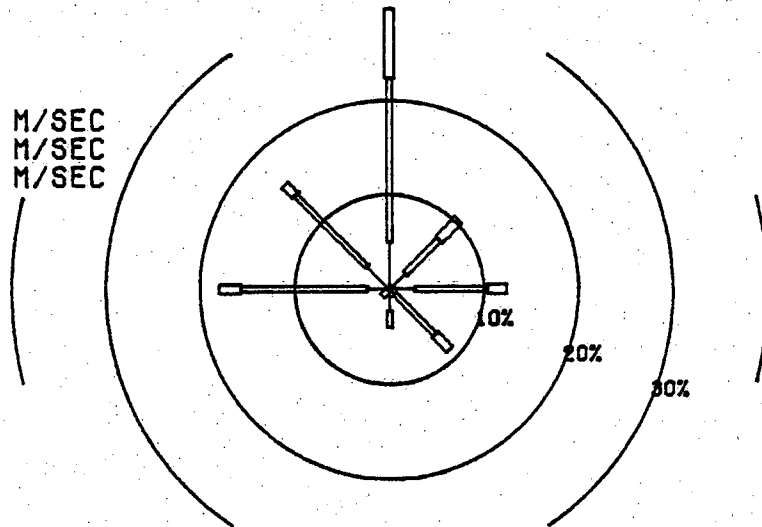

CURRENT  
 — 0-5 CM/SEC  
 = 5-15 CM/SEC  
 = 15 CM/SEC

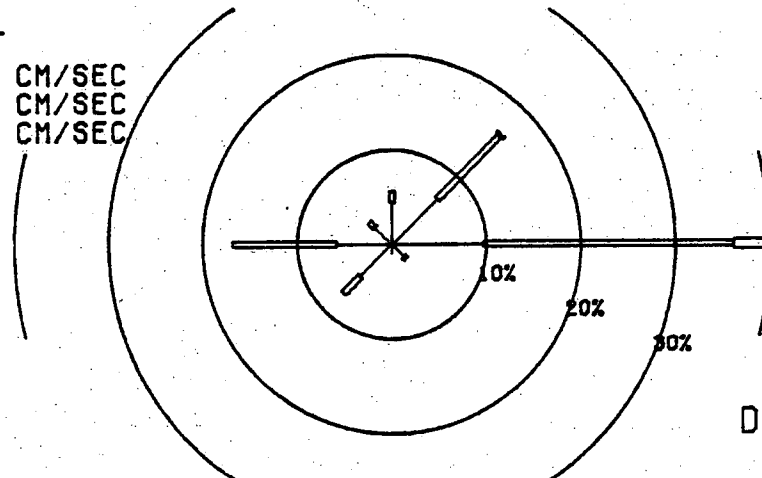

DEPTH: 10 M

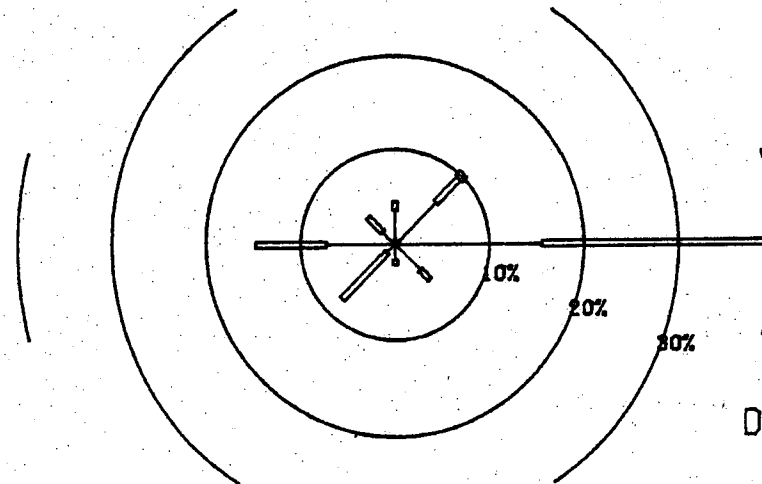

DEPTH: 38 M

\* DIRECTION TOWARDS

MOORING : 31

DATE : MAR 1974

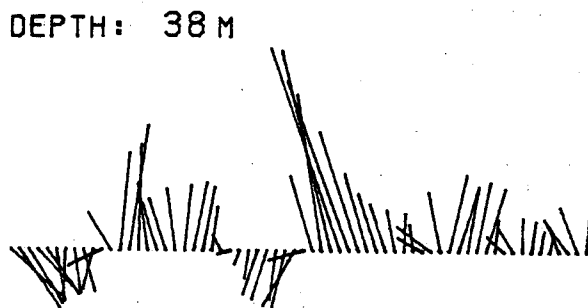
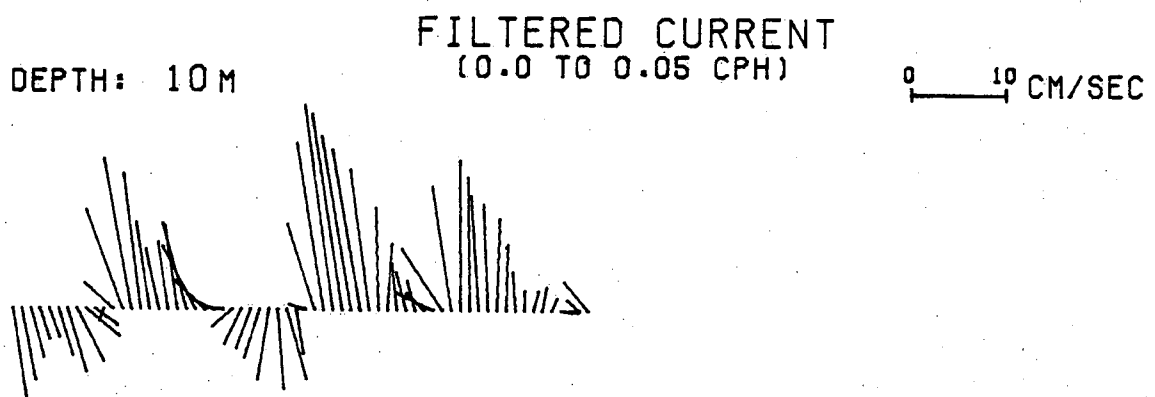
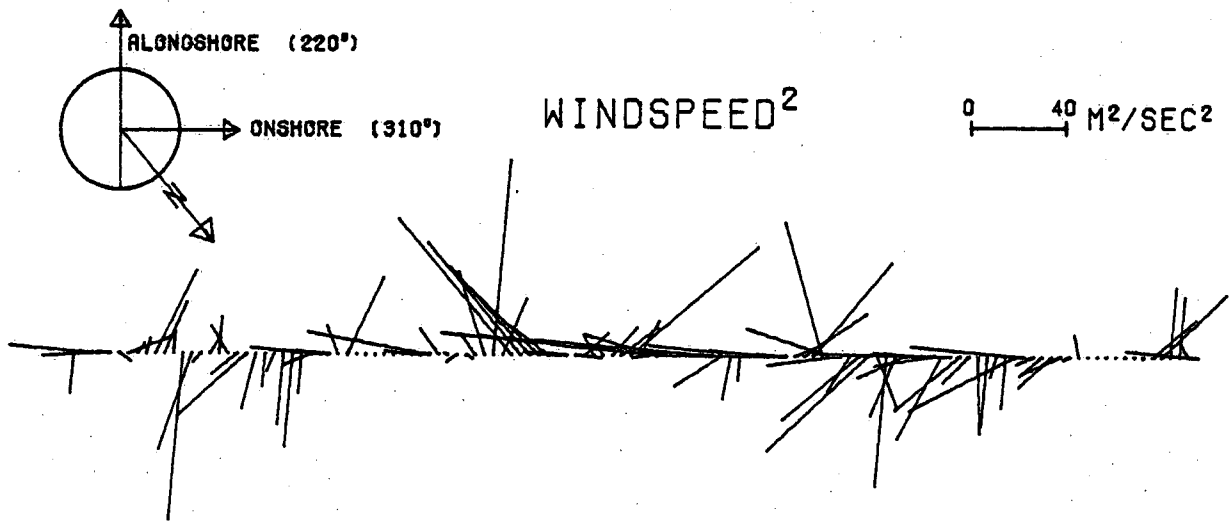

1 2 3 4 5 6 7 8 9 10 11 12 13 14 15 16 17 18 19 20 21 22 23 24 25 26 27 28 29 30 31

MOORING: 32      DATE: MAR 1974  
 MONTHLY SUMMARY: WIND AND CURRENT\*

WIND  
 — 0-3 M/SEC  
 = 3-7 M/SEC  
 ≡ ≥ 7 M/SEC

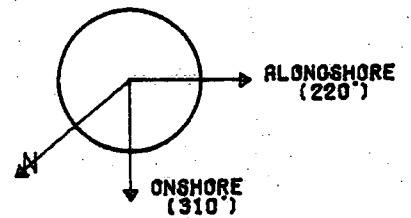
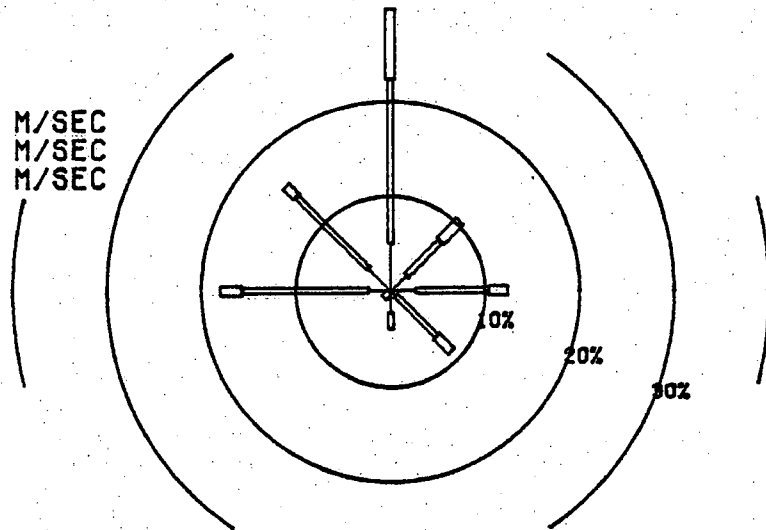

CURRENT  
 — 0-5 CM/SEC  
 = 5-15 CM/SEC  
 ≡ ≥ 15 CM/SEC

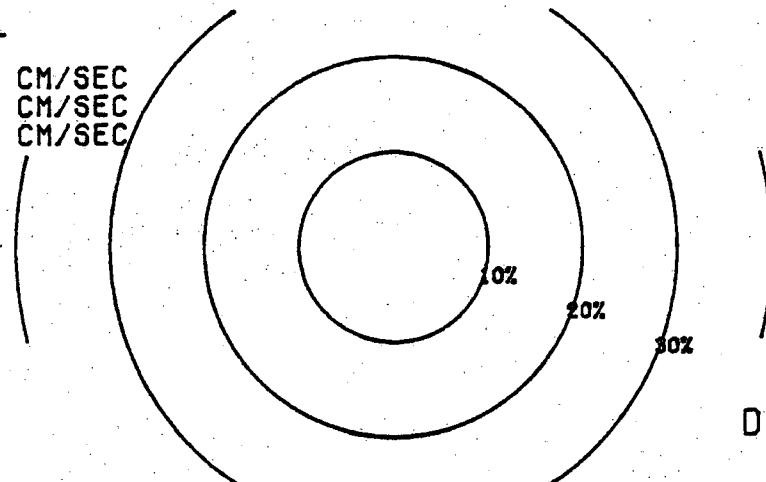

DEPTH: 0 M

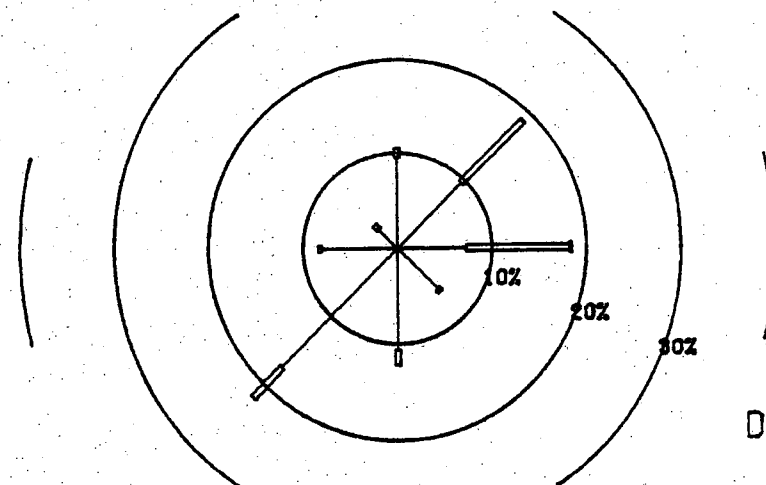

DEPTH: 51 M

\* DIRECTION TOWARDS

MOORING : 32

DATE : MAR 1974

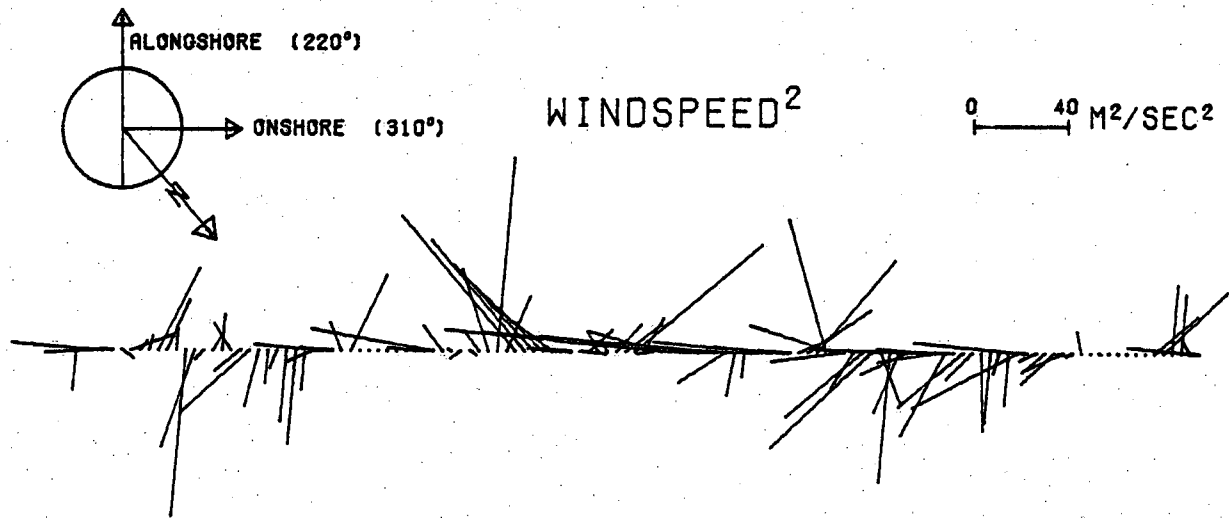

DEPTH: M

FILTERED CURRENT  
(0.0 TO 0.05 CPH)

0 10 CM/SEC

DEPTH: 51 M

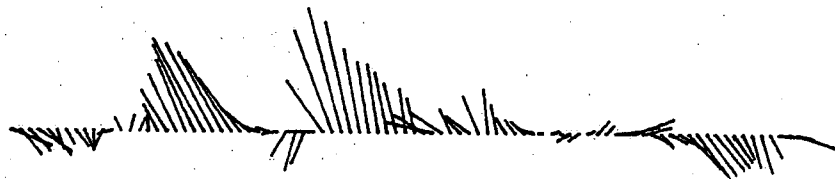

1 2 3 4 5 6 7 8 9 10 11 12 13 14 15 16 17 18 19 20 21 22 23 24 25 26 27 28 29 30 31

MOORING: 33      DATE: MAR 1974  
 MONTHLY SUMMARY: WIND AND CURRENT\*

WIND  
 — 0-3 M/SEC  
 = 3-7 M/SEC  
 ≡ ≥ 7 M/SEC

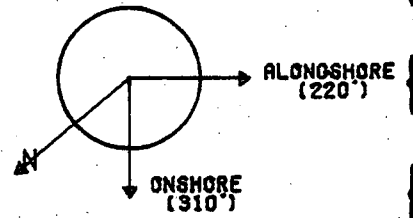
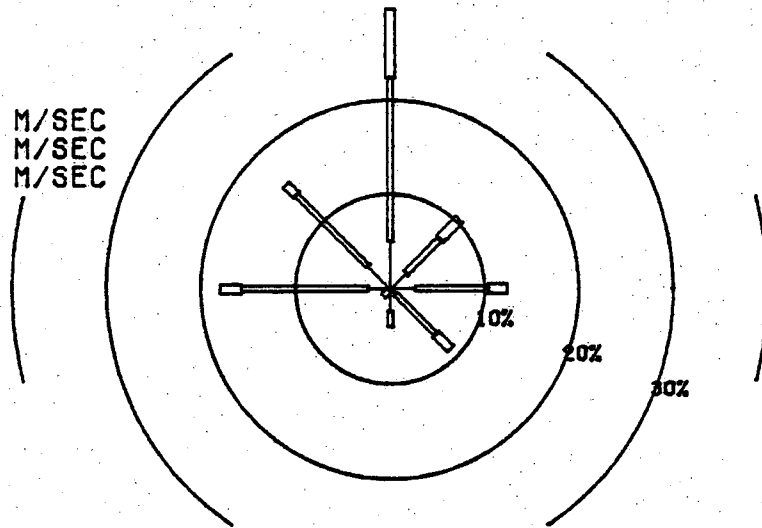

CURRENT  
 — 0-5 CM/SEC  
 = 5-15 CM/SEC  
 ≡ ≥ 15 CM/SEC

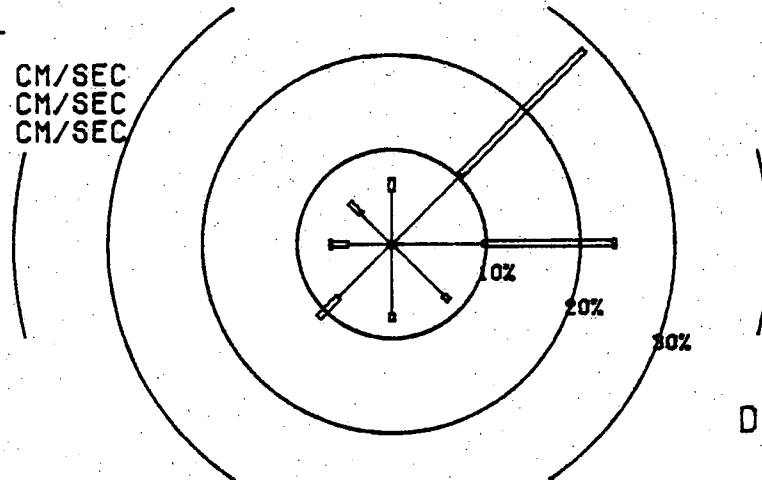

DEPTH: 10 M

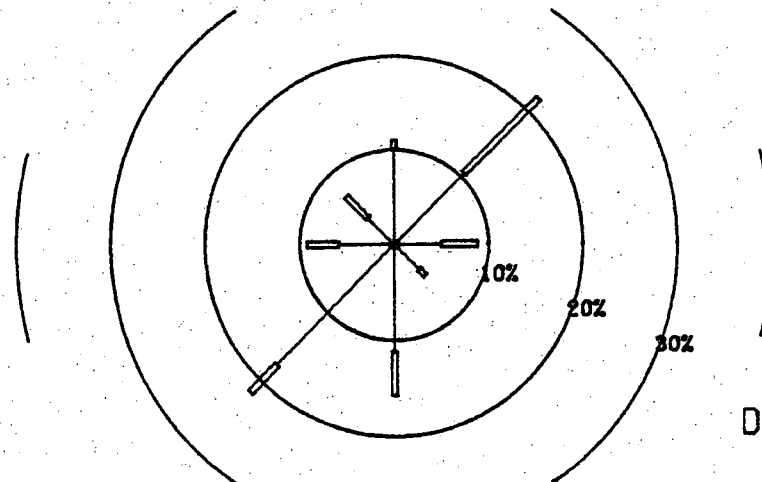

DEPTH: 61 M

\* DIRECTION TOWARDS

MOORING : 33

DATE : MAR 1974

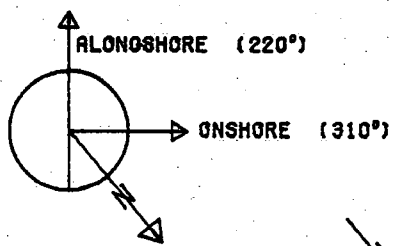

WINDSPEED<sup>2</sup>

0 40 M<sup>2</sup>/SEC<sup>2</sup>

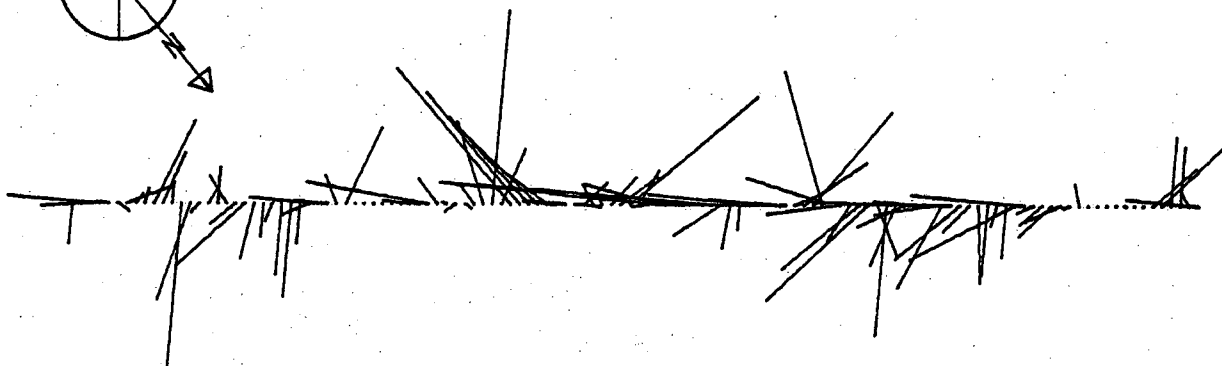

FILTERED CURRENT  
(0.0 TO 0.05 CPH)

DEPTH: 10 M

0 10 CM/SEC

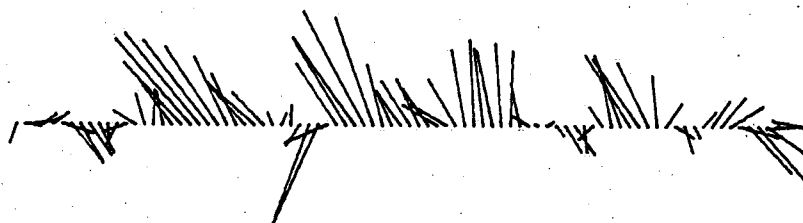

DEPTH: 61 M

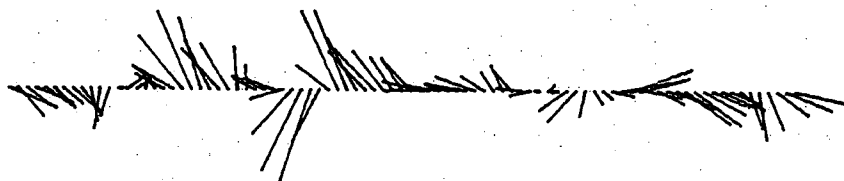

1 2 3 4 5 6 7 8 9 10 11 12 13 14 15 16 17 18 19 20 21 22 23 24 25 26 27 28 29 30 31



MOORING: 34      DATE: MAR 1974  
 MONTHLY SUMMARY: WIND AND CURRENT\*

WIND  
 — 0-3 M/SEC  
 = 3-7 M/SEC  
 ≡ ≥ 7 M/SEC

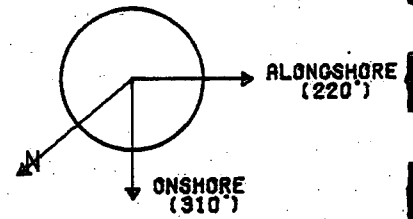
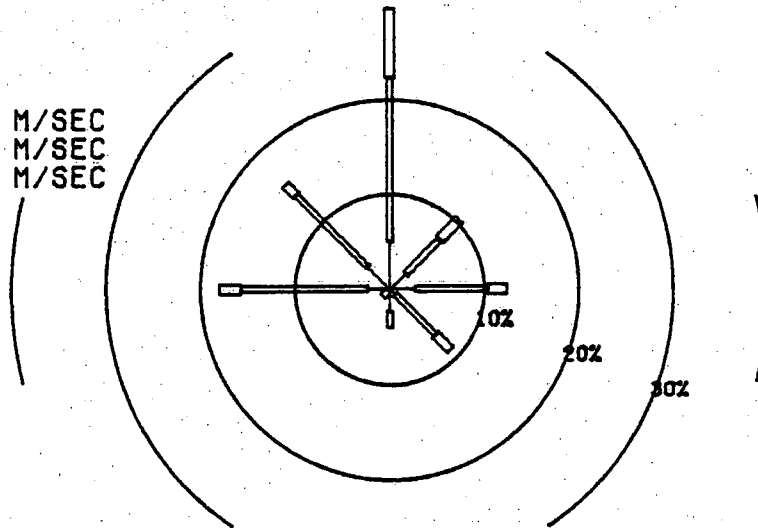

CURRENT  
 — 0-5 CM/SEC  
 = 5-15 CM/SEC  
 ≡ ≥ 15 CM/SEC

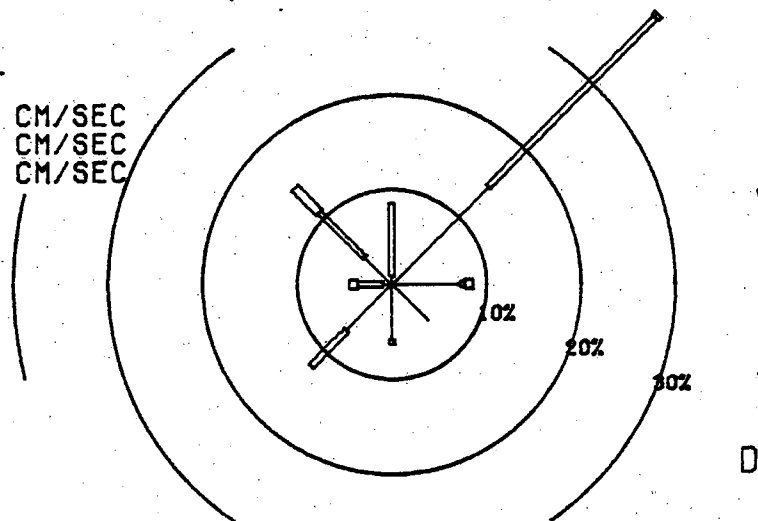

DEPTH: 10 M

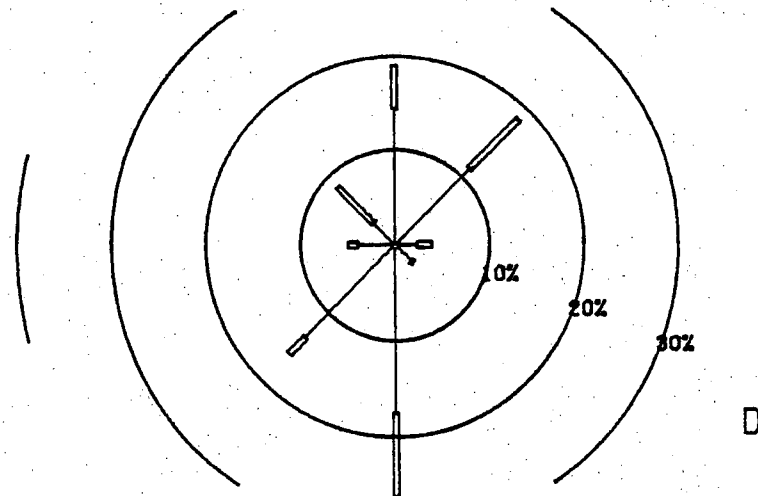

DEPTH: 63 M

\* DIRECTION TOWARDS

MOORING: 34

DATE: MAR 1974

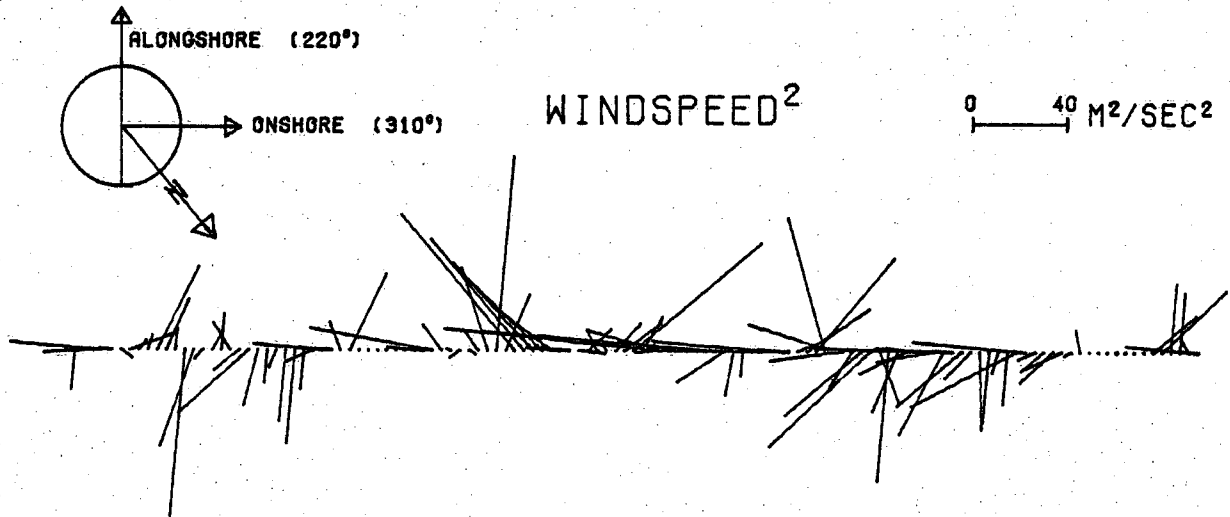

DEPTH: 10 M

FILTERED CURRENT  
(0.0 TO 0.05 CPH)

0 10 CM/SEC



DEPTH: 63 M



1' 2' 3' 4' 5' 6' 7' 8' 9' 10' 11' 12' 13' 14' 15' 16' 17' 18' 19' 20' 21' 22' 23' 24' 25' 26' 27' 28' 29' 30' 31'

APPENDIX C: CURRENT SPEED AND DIRECTION WITH TEMPERATURE SUMMARY

MOORING: 21

DATE: JUNE 1973

TEMPERATURE °C

△ - 9 M  
○ - 16 M

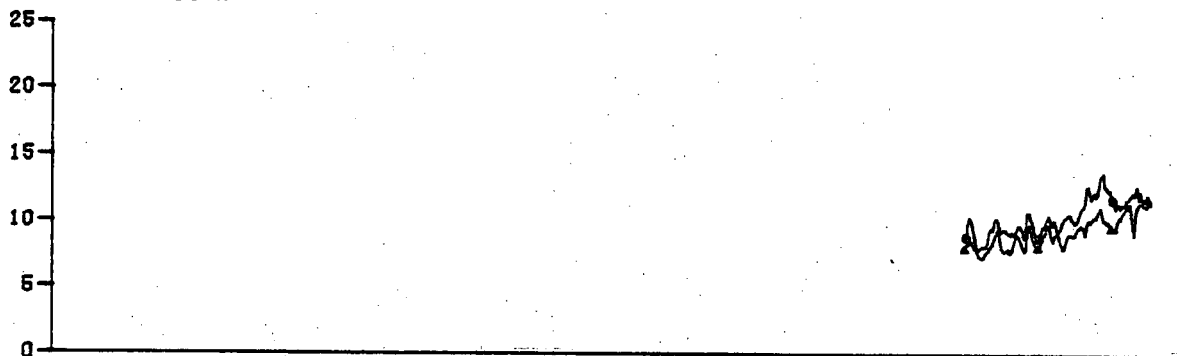

FILTERED CURRENT (0.0 TO 0.2 CPH) CM/SEC

DEPTH: 9 M

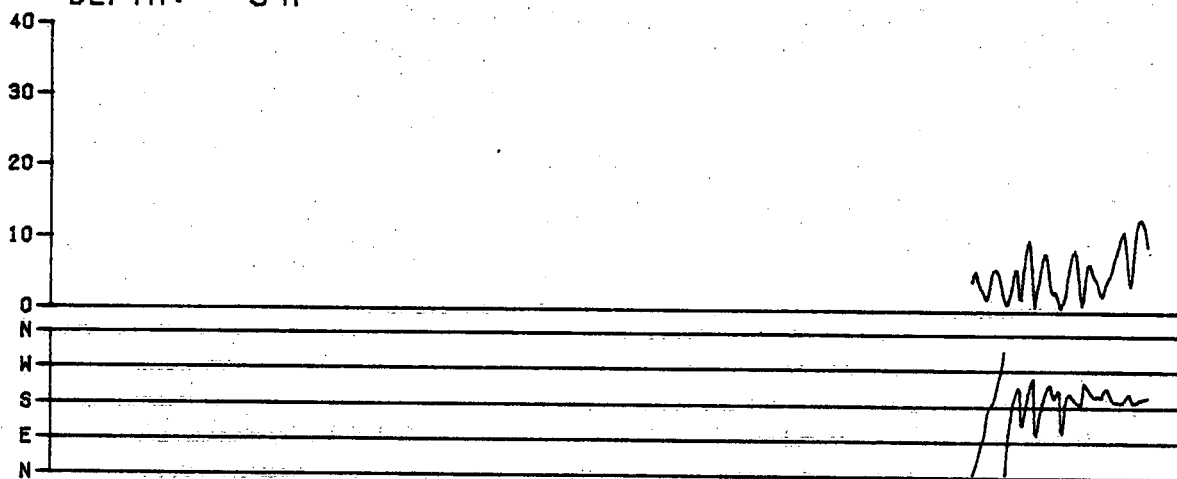

DEPTH: 16 M

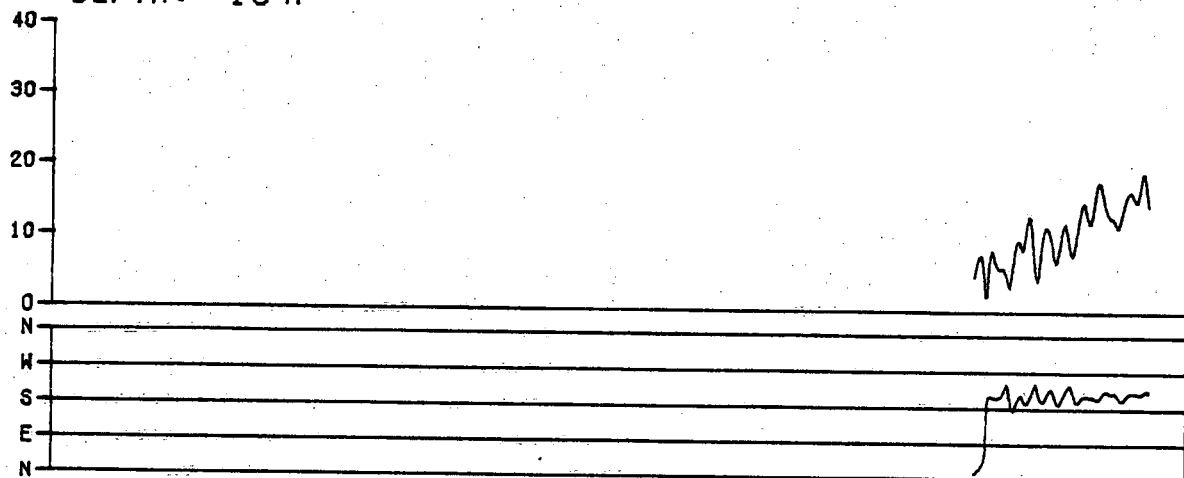

1 2 3 4 5 6 7 8 9 10 11 12 13 14 15 16 17 18 19 20 21 22 23 24 25 26 27 28 29 30 31

MOORING: 22

DATE: JUNE 1973

TEMPERATURE °C

△ - 9 M  
○ - 27 M

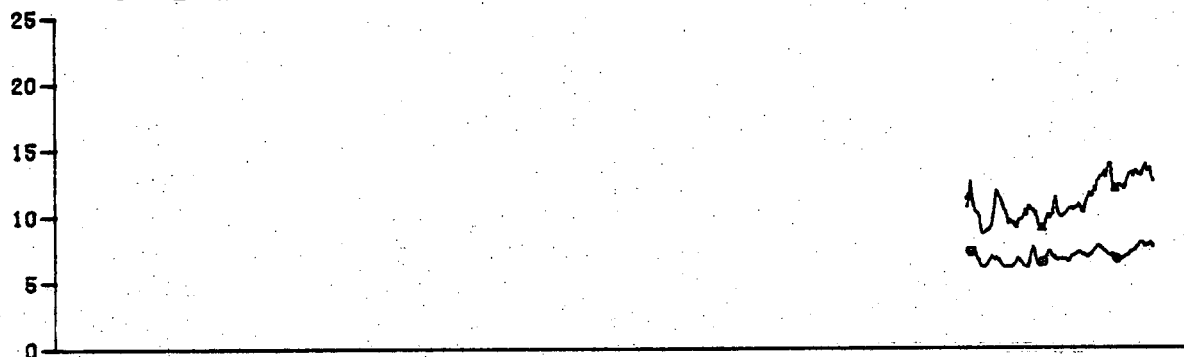

FILTERED CURRENT (0.0 TO 0.2 CPH) CM/SEC

DEPTH: 9 M

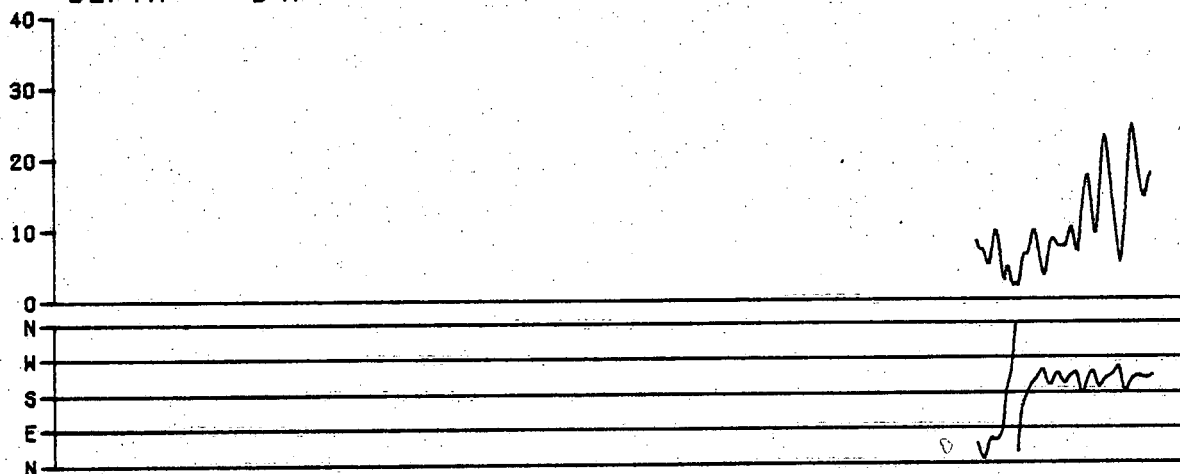

DEPTH: 27 M

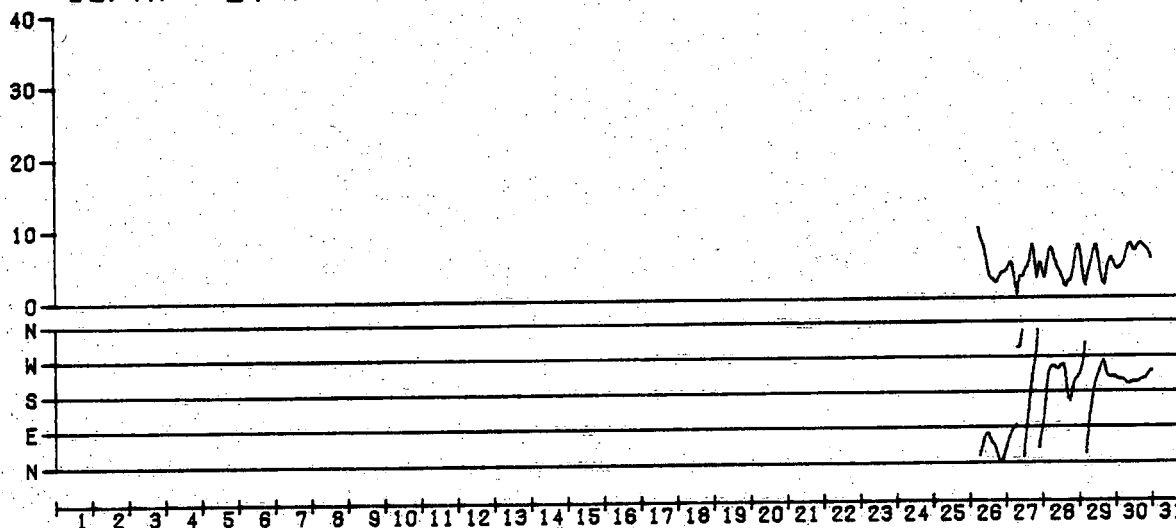

MOORING: 23

DATE: JUNE 1973

TEMPERATURE °C

△ - 9 M  
○ - 30 M

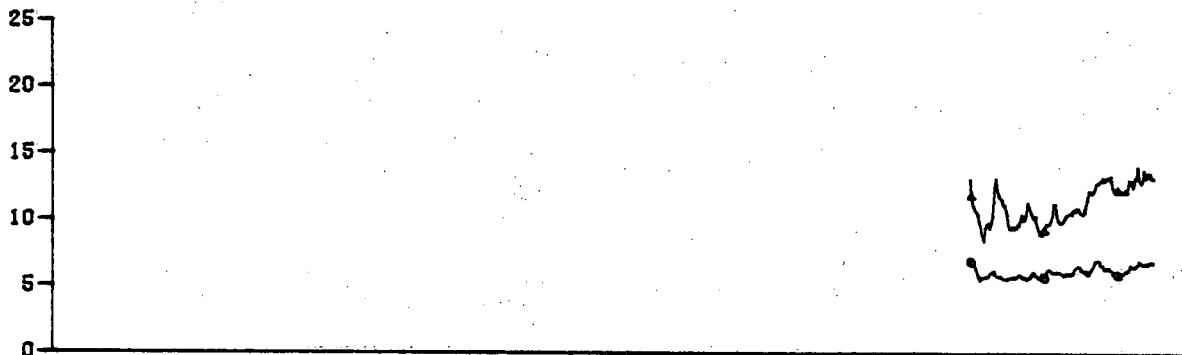

FILTERED CURRENT (0.0 TO 0.2 CPH) CM/SEC

DEPTH: 9 M

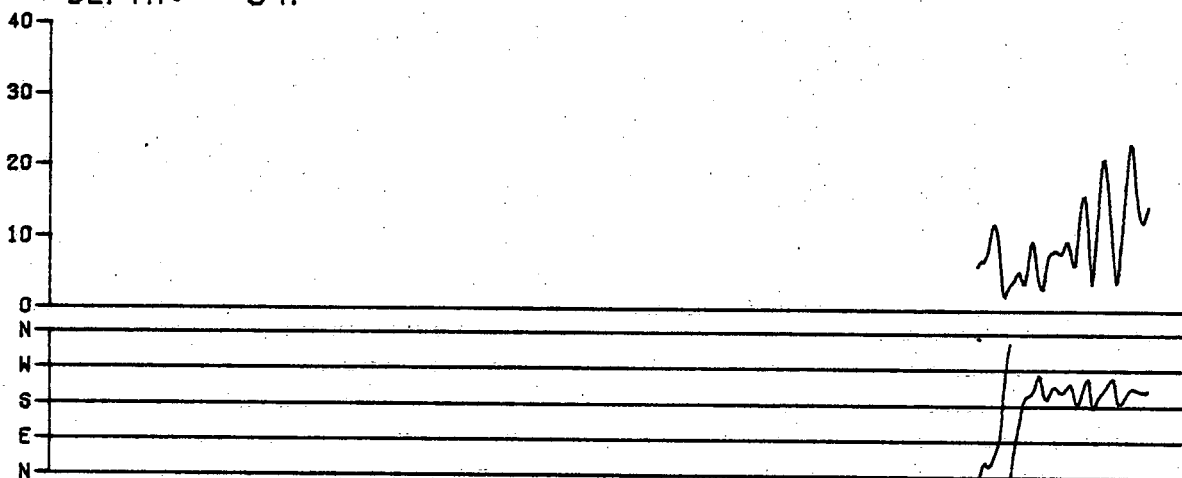

DEPTH: 30 M

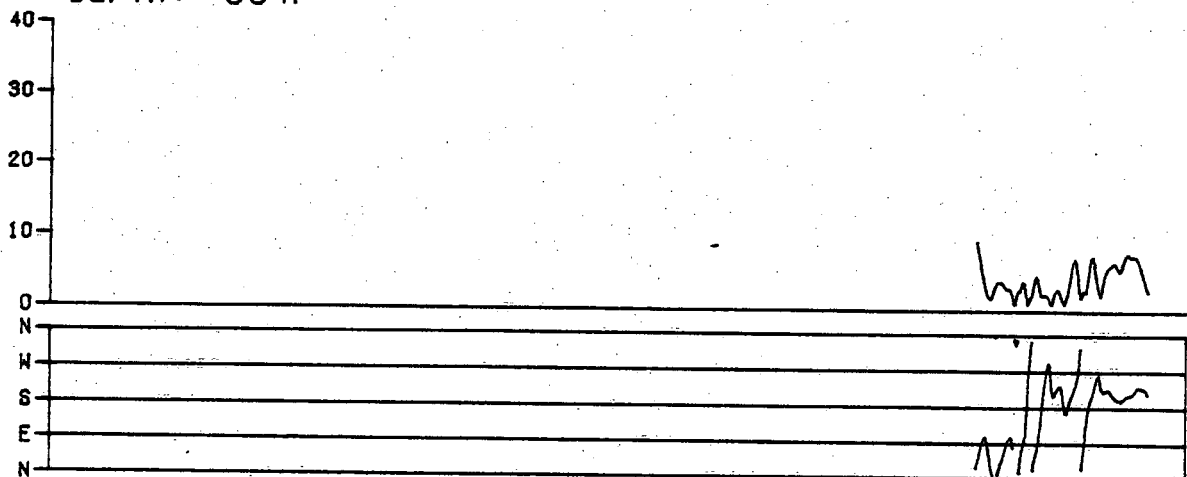

1 2 3 4 5 6 7 8 9 10 11 12 13 14 15 16 17 18 19 20 21 22 23 24 25 26 27 28 29 30 31

MOORING : 25

DATE : JUNE 1973

TEMPERATURE °C

▲ - 9 M  
○ - M

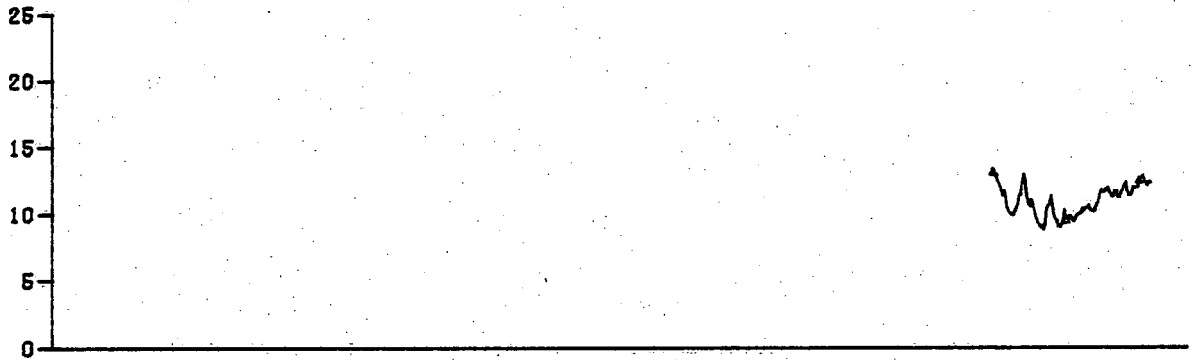

FILTERED CURRENT (0.0 TO 0.2 CPH) CM/SEC

DEPTH: 9 M

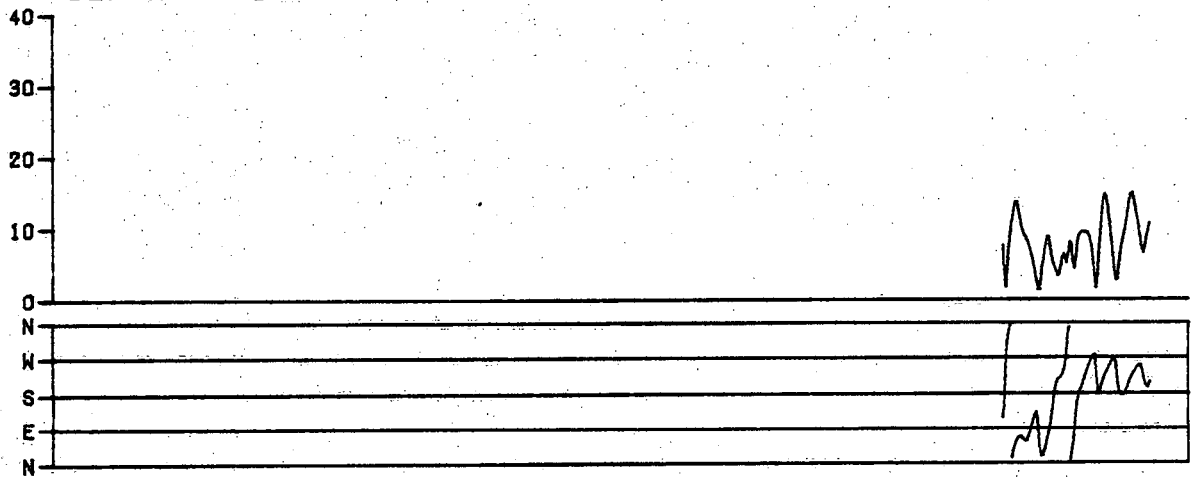

DEPTH: M

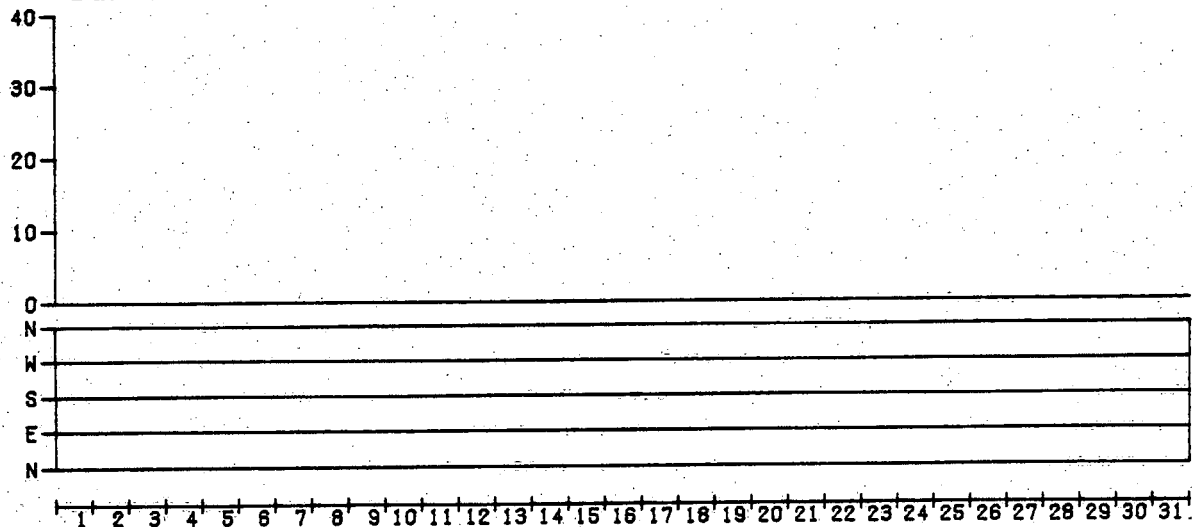

MOORING : 26

DATE : JUNE 1973

TEMPERATURE °C

△ - 9 M  
○ - M

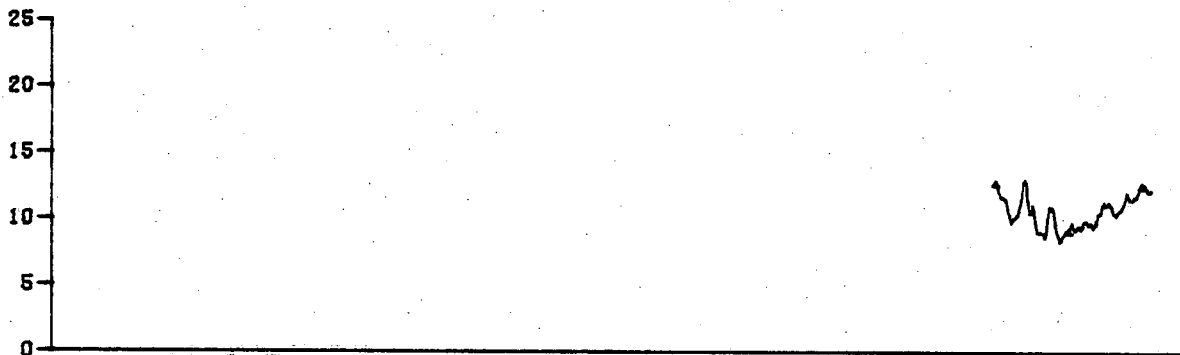

FILTERED CURRENT (0.0 TO 0.2 CPH) CM/SEC

DEPTH: 9 M

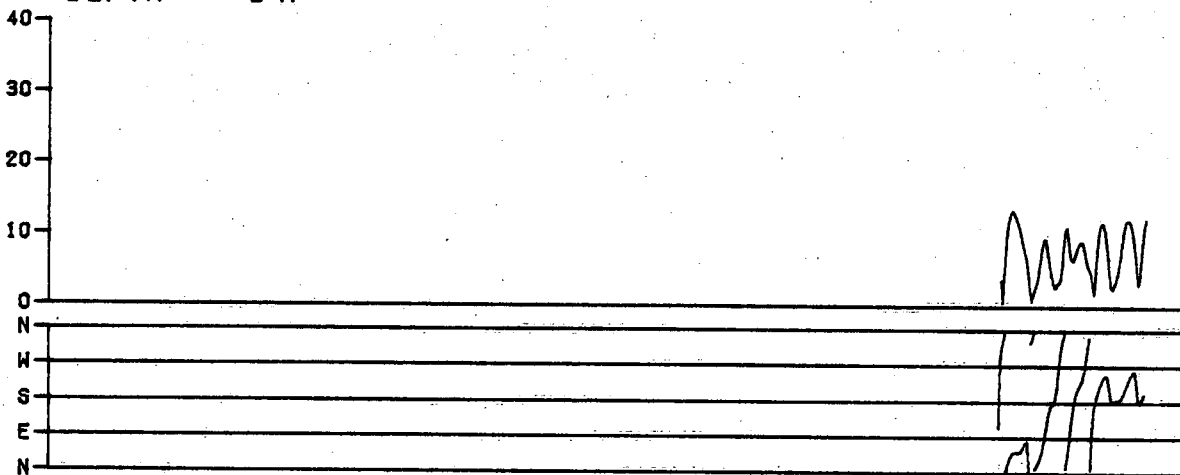

DEPTH: M

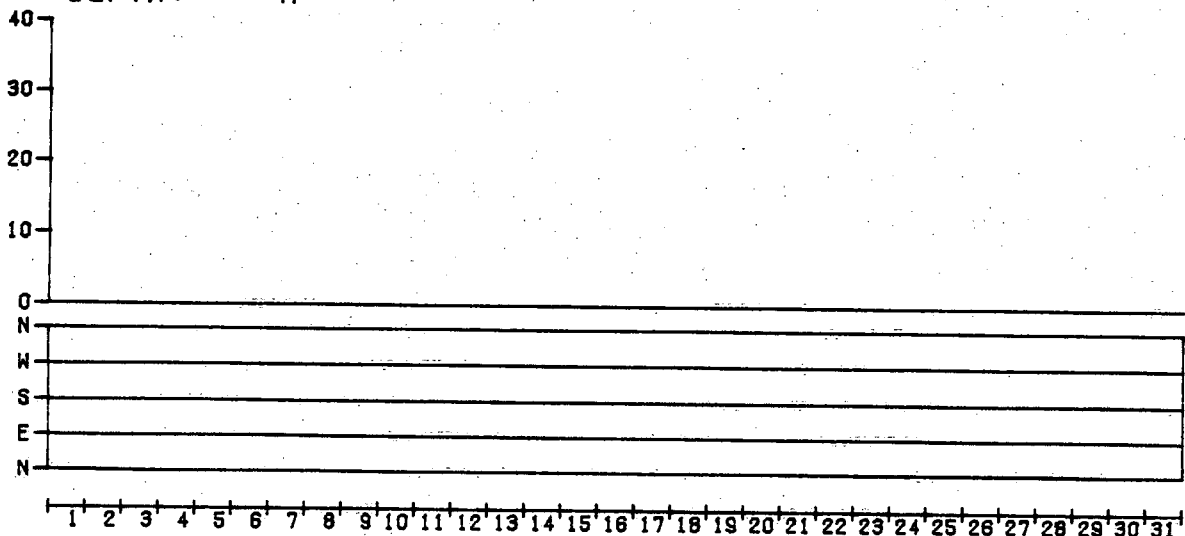

1' 2' 3' 4' 5' 6' 7' 8' 9' 10' 11' 12' 13' 14' 15' 16' 17' 18' 19' 20' 21' 22' 23' 24' 25' 26' 27' 28' 29' 30' 31'



MOORING: 27

DATE: JUNE 1973

TEMPERATURE °C

△ - 9 M  
⊙ - M

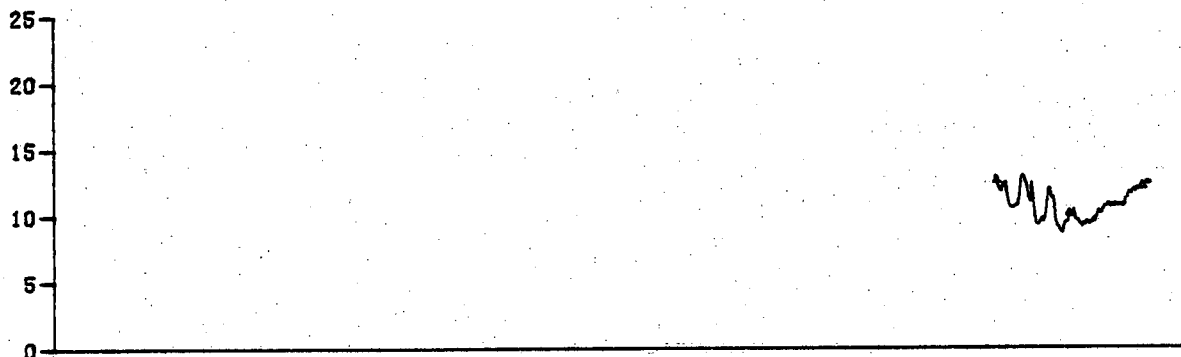

FILTERED CURRENT (0.0 TO 0.2 CPH) CM/SEC

DEPTH: 9 M

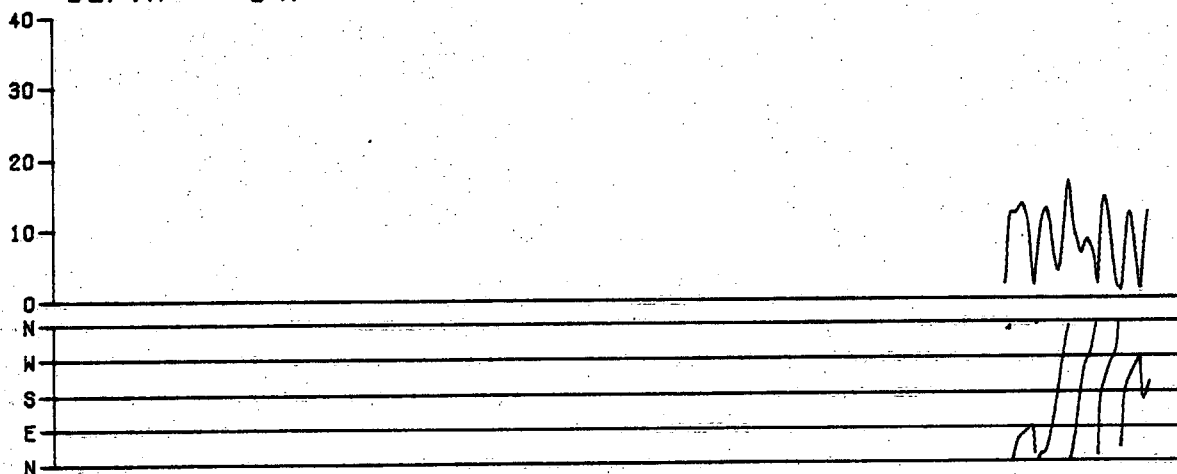

DEPTH: M

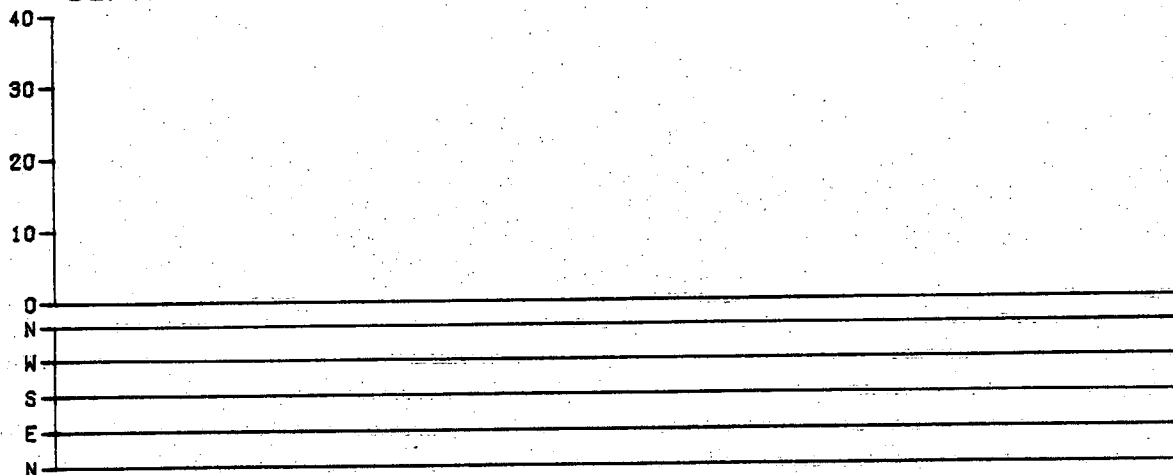

1' 2' 3' 4' 5' 6' 7' 8' 9' 10' 11' 12' 13' 14' 15' 16' 17' 18' 19' 20' 21' 22' 23' 24' 25' 26' 27' 28' 29' 30' 31'

MOORING : 28

DATE : JUNE 1973

TEMPERATURE °C

△ - 8 M  
○ - H

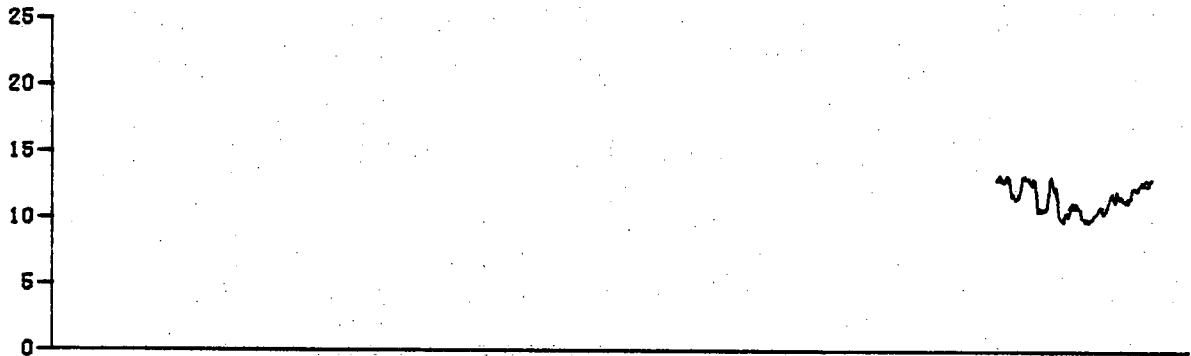

FILTERED CURRENT (0.0 TO 0.2 CPH) CM/SEC

DEPTH: 8 M

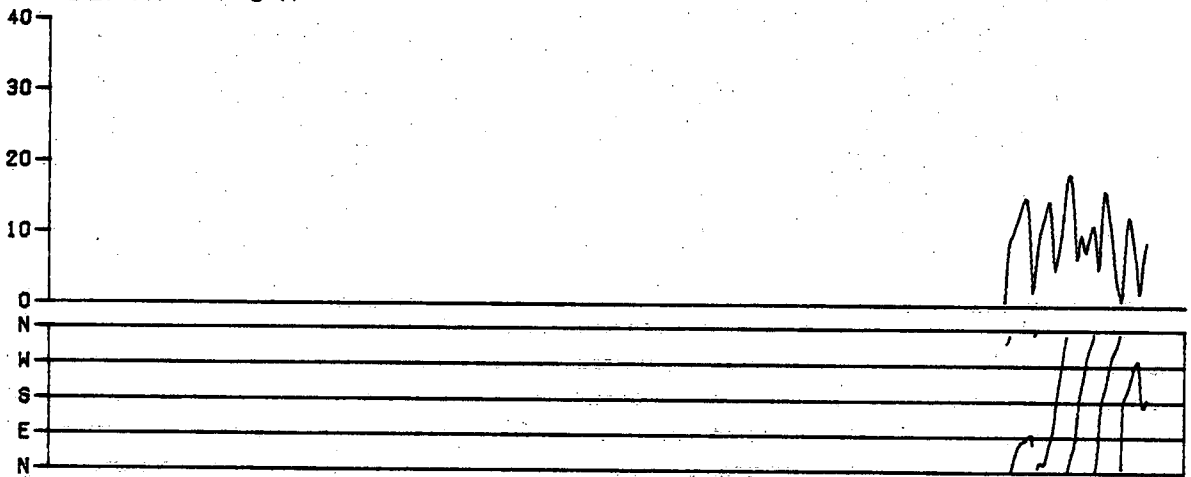

DEPTH: M

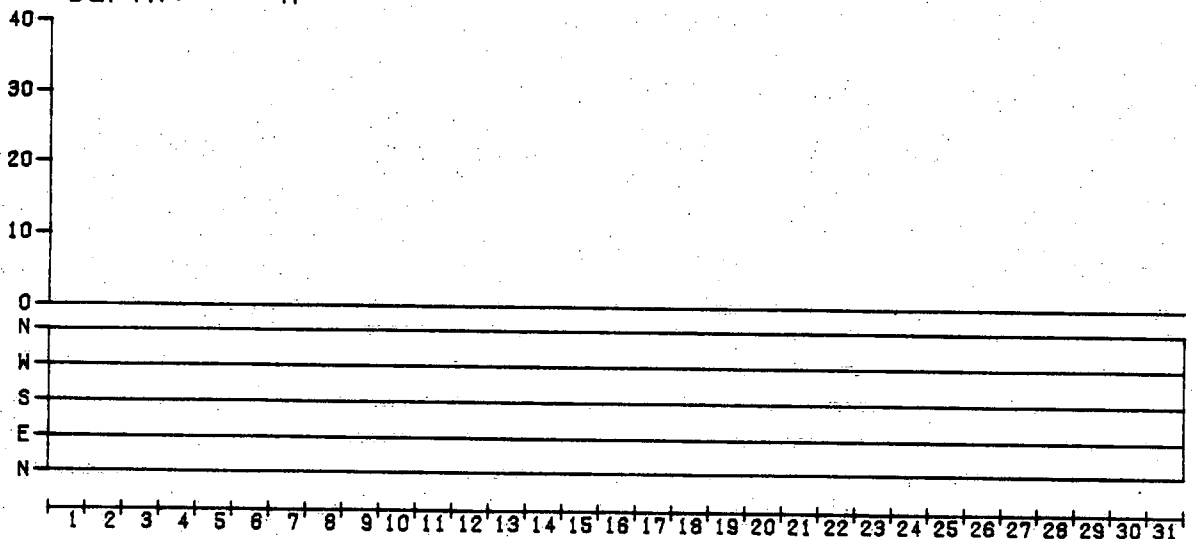

MOORING: 21

DATE: JULY 1973

TEMPERATURE °C

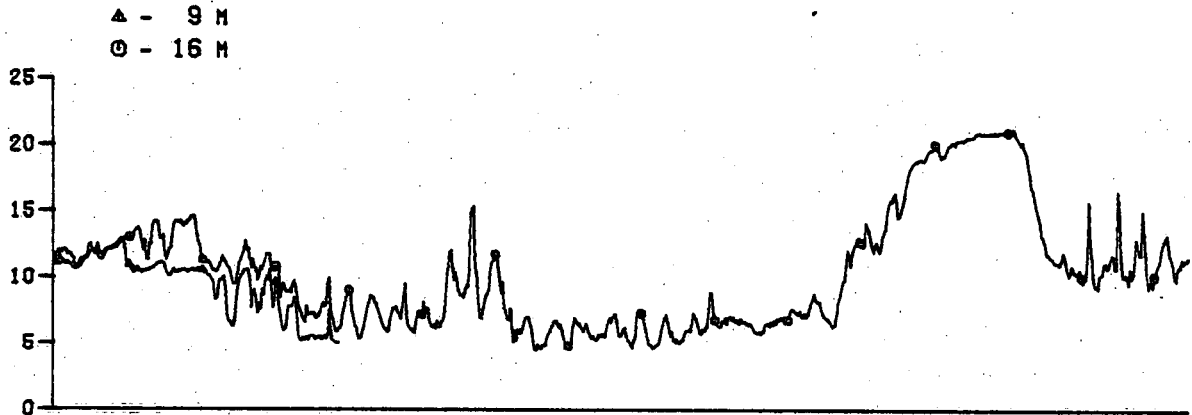

FILTERED CURRENT (0.0 TO 0.2 CPH) CM/SEC

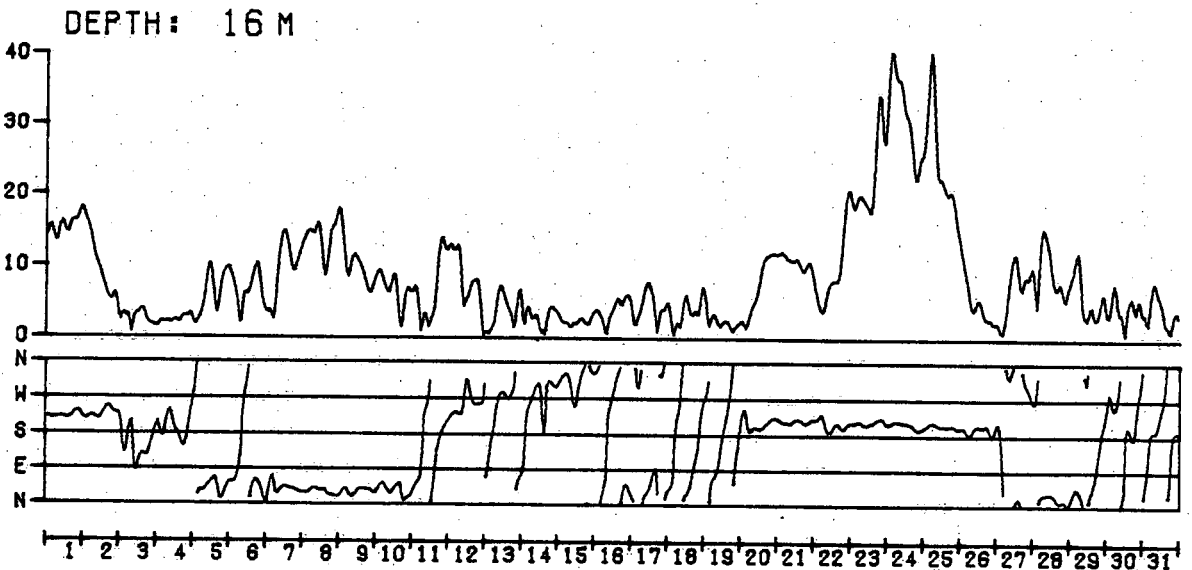
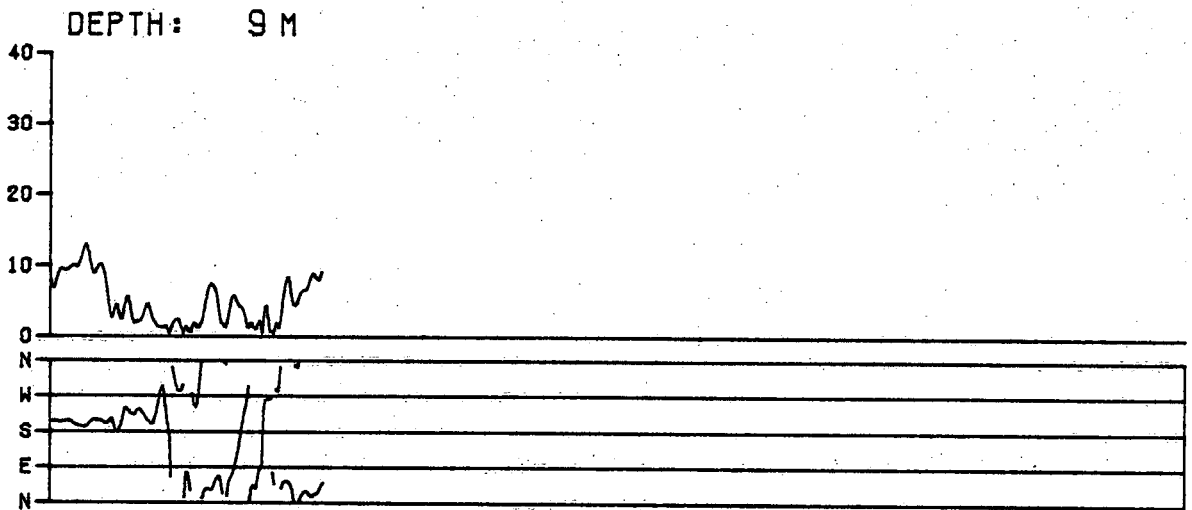

1' 2' 3' 4' 5' 6' 7' 8' 9' 10' 11' 12' 13' 14' 15' 16' 17' 18' 19' 20' 21' 22' 23' 24' 25' 26' 27' 28' 29' 30' 31'

MOORING : 22

DATE : JULY 1973

TEMPERATURE °C

△ - 9 M  
○ - 27 M

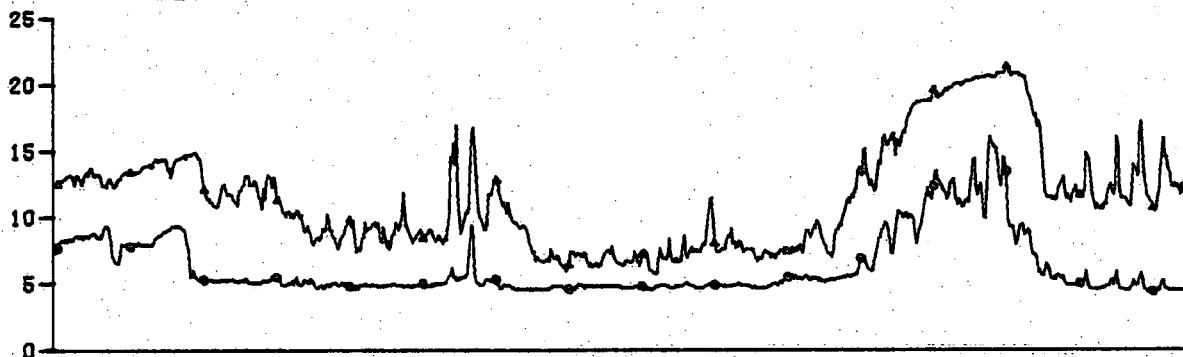

FILTERED CURRENT (0.0 TO 0.2 CPH) CM/SEC

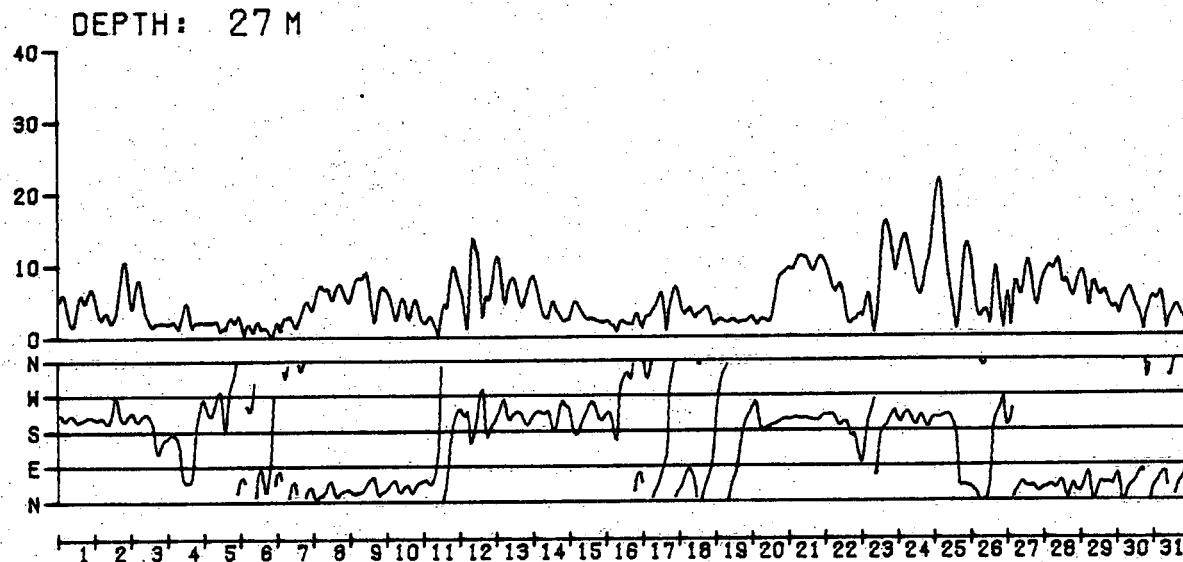
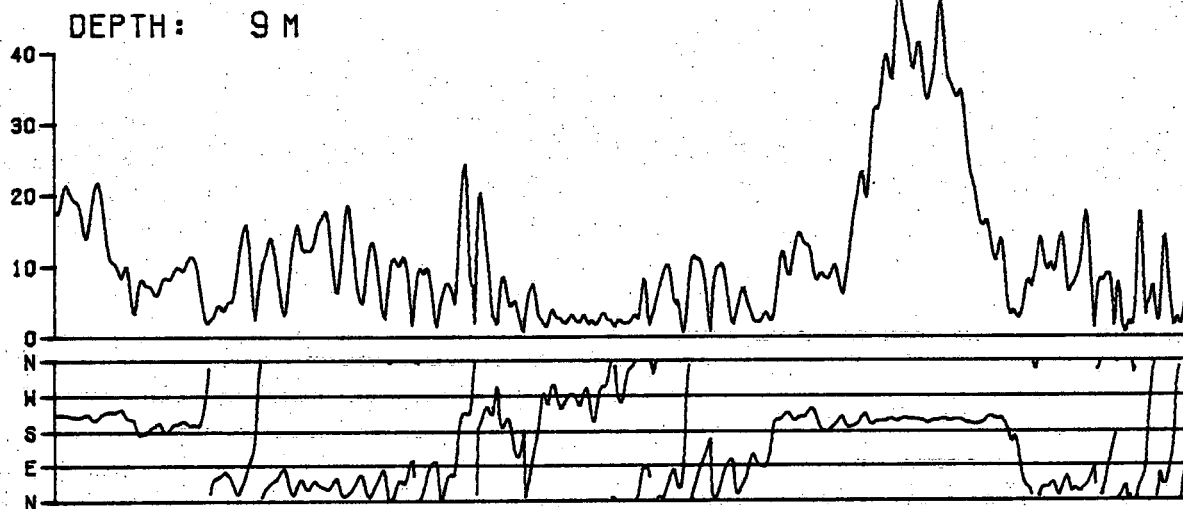

1' 2' 3' 4' 5' 6' 7' 8' 9' 10' 11' 12' 13' 14' 15' 16' 17' 18' 19' 20' 21' 22' 23' 24' 25' 26' 27' 28' 29' 30' 31'

MOORING : 23

DATE : JULY 1973

TEMPERATURE °C

△ - 9 M  
○ - 30 M

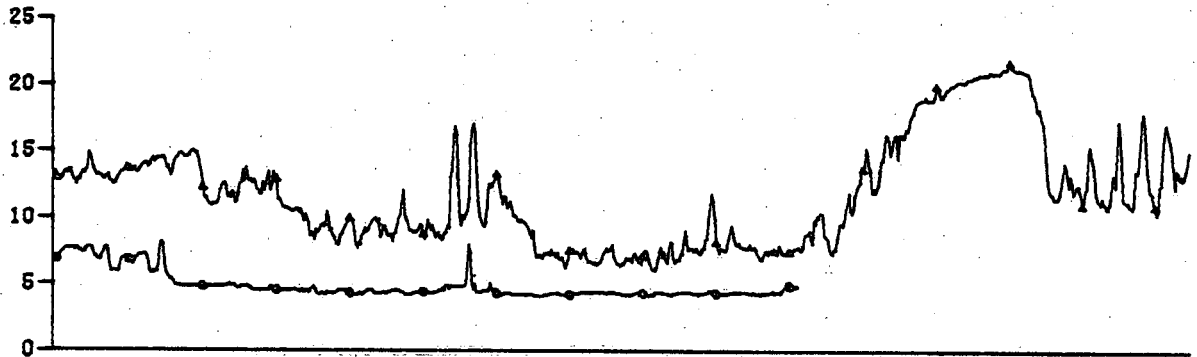

FILTERED CURRENT (0.0 TO 0.2 CPH) CM/SEC

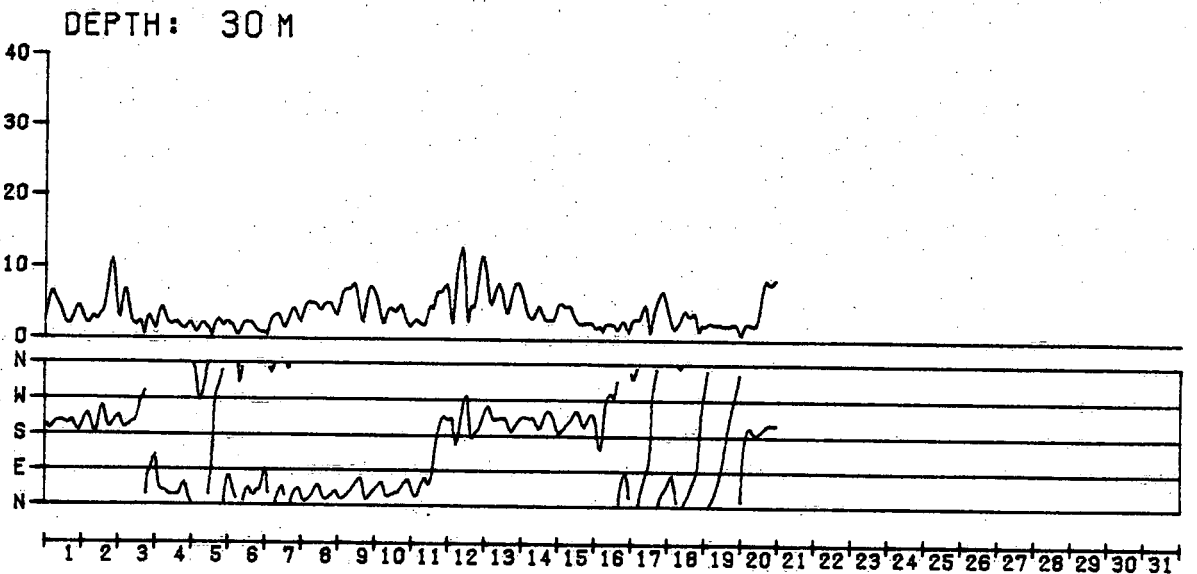
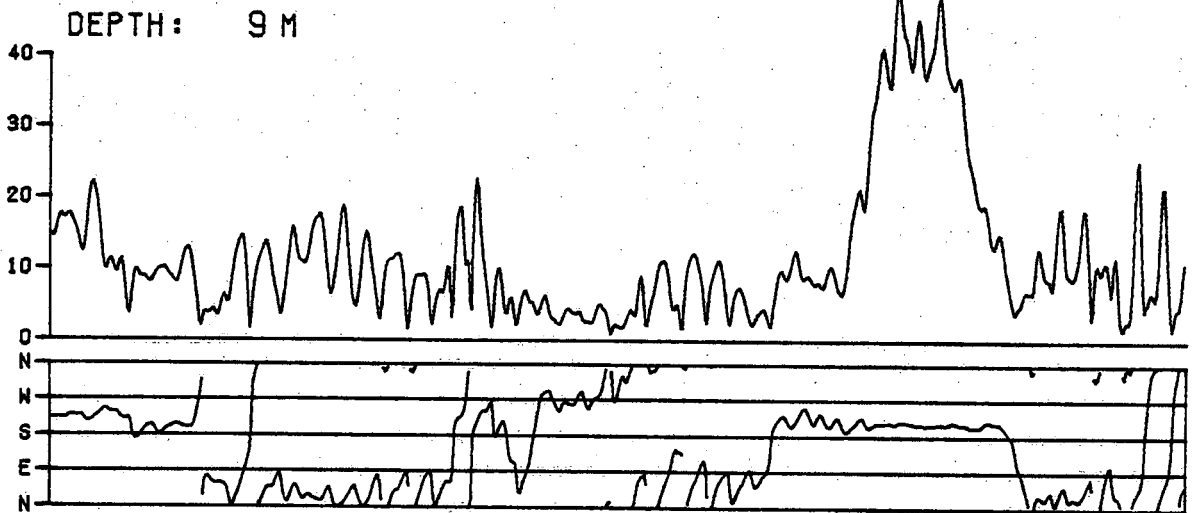

MOORING : 25

DATE : JULY 1973

TEMPERATURE °C

△ - 9 M  
○ - M

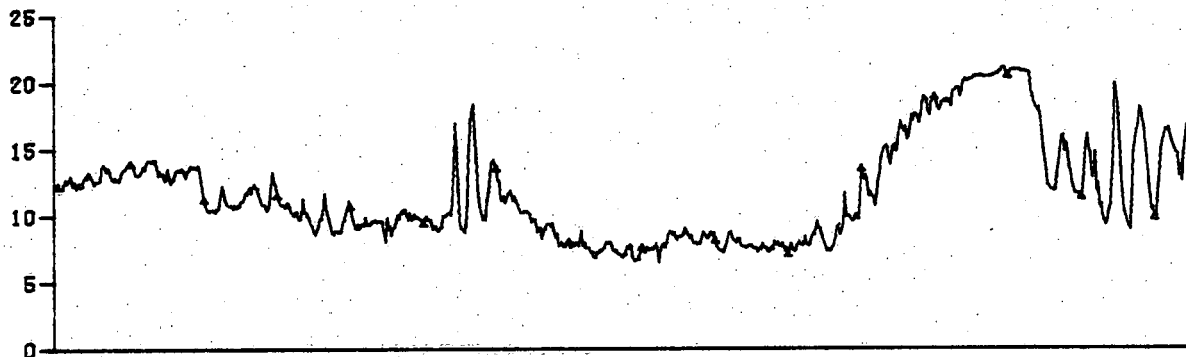

FILTERED CURRENT (0.0 TO 0.2 CPH) CM/SEC

DEPTH: 9 M

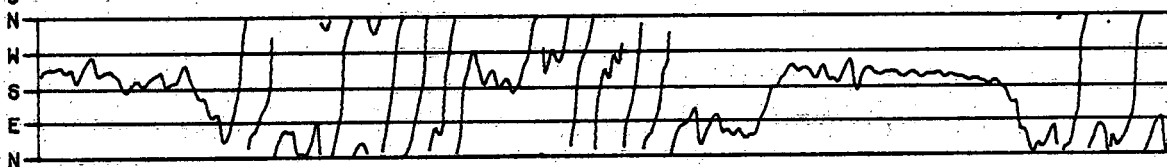
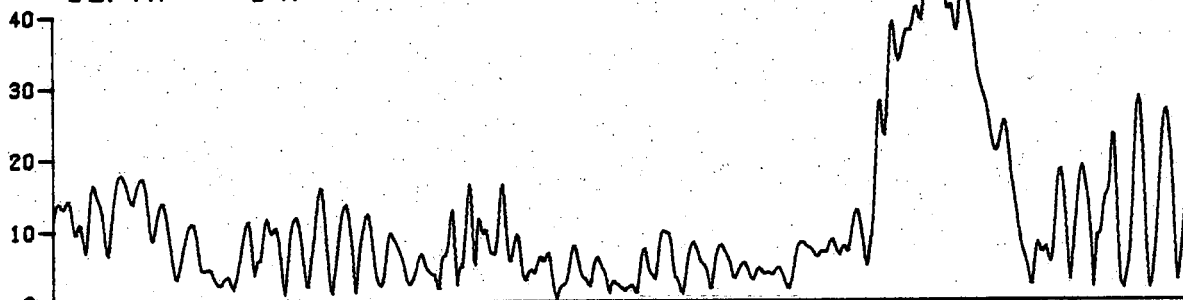

DEPTH: M



1 2 3 4 5 6 7 8 9 10 11 12 13 14 15 16 17 18 19 20 21 22 23 24 25 26 27 28 29 30 31

MOORING: 26

DATE: JULY 1973

TEMPERATURE °C

Δ - 9 M  
○ - M

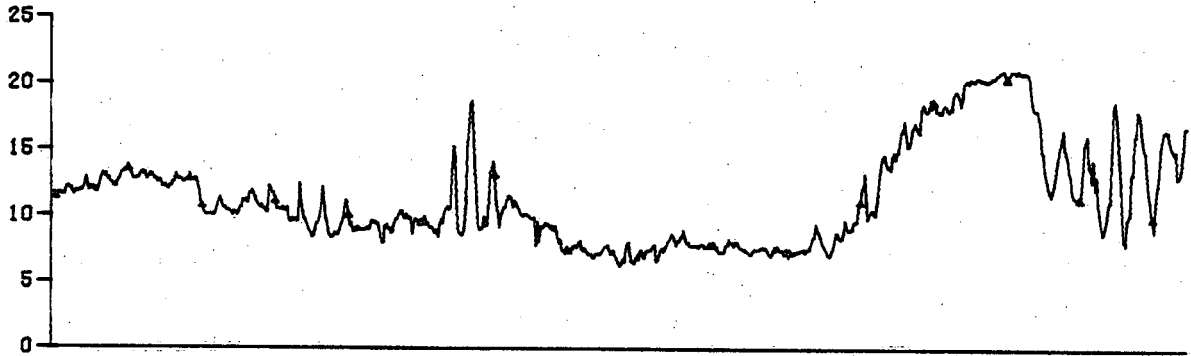

FILTERED CURRENT (0.0 TO 0.2 CPH) CM/SEC

DEPTH: 9 M

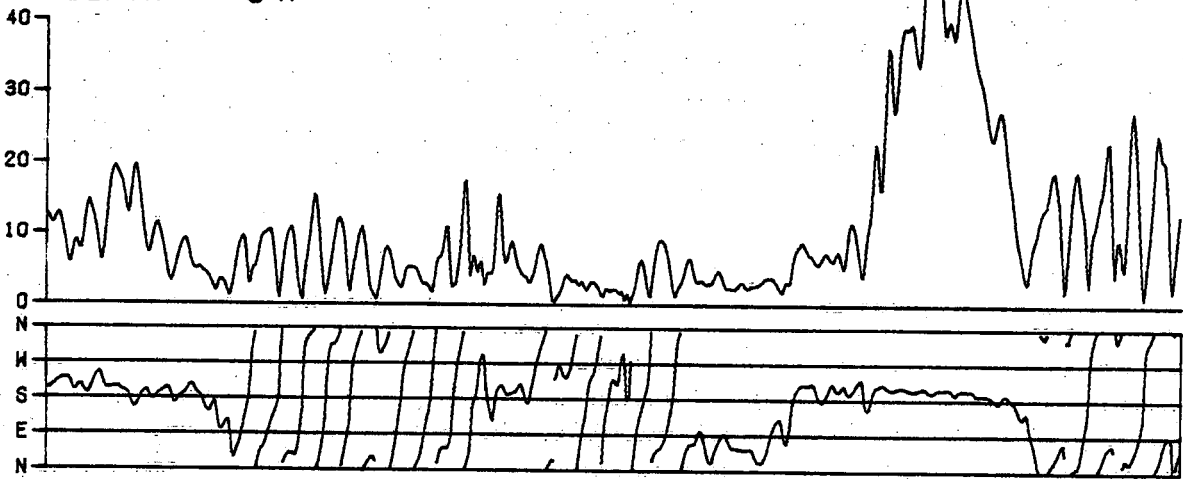

DEPTH: M

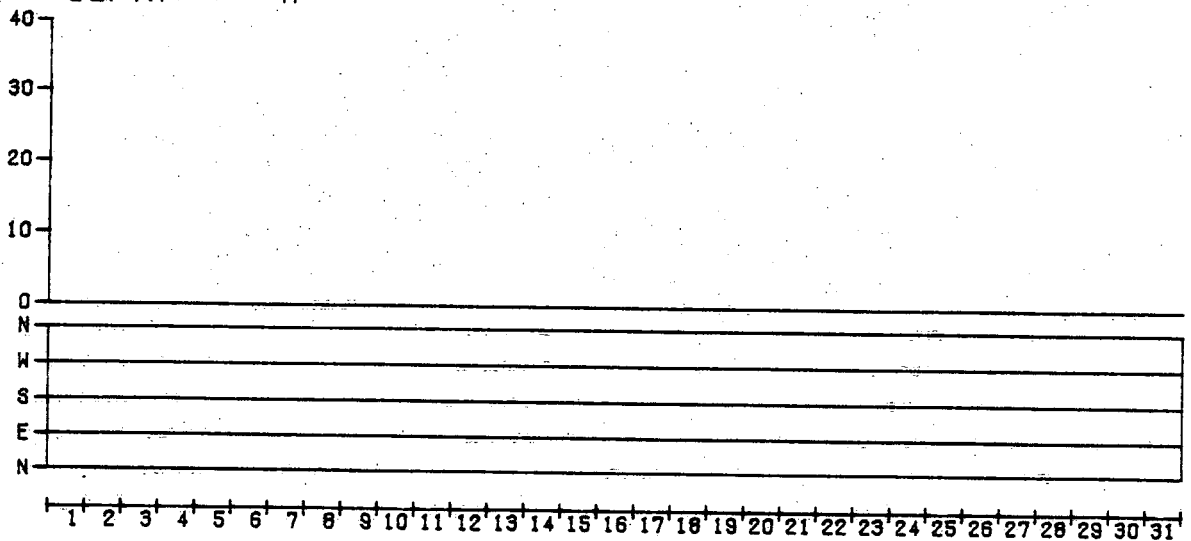

MOORING: 27

DATE: JULY 1973

TEMPERATURE °C

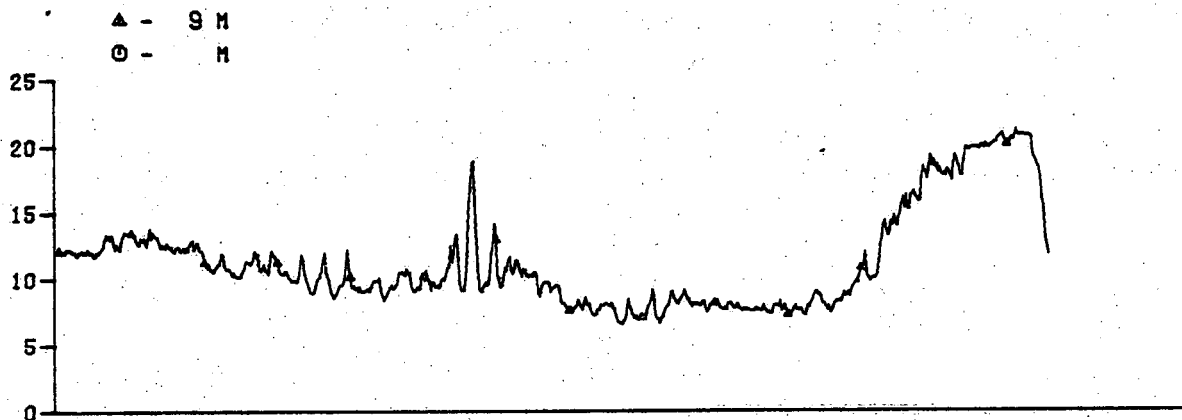

FILTERED CURRENT (0.0 TO 0.2 CPH) CM/SEC

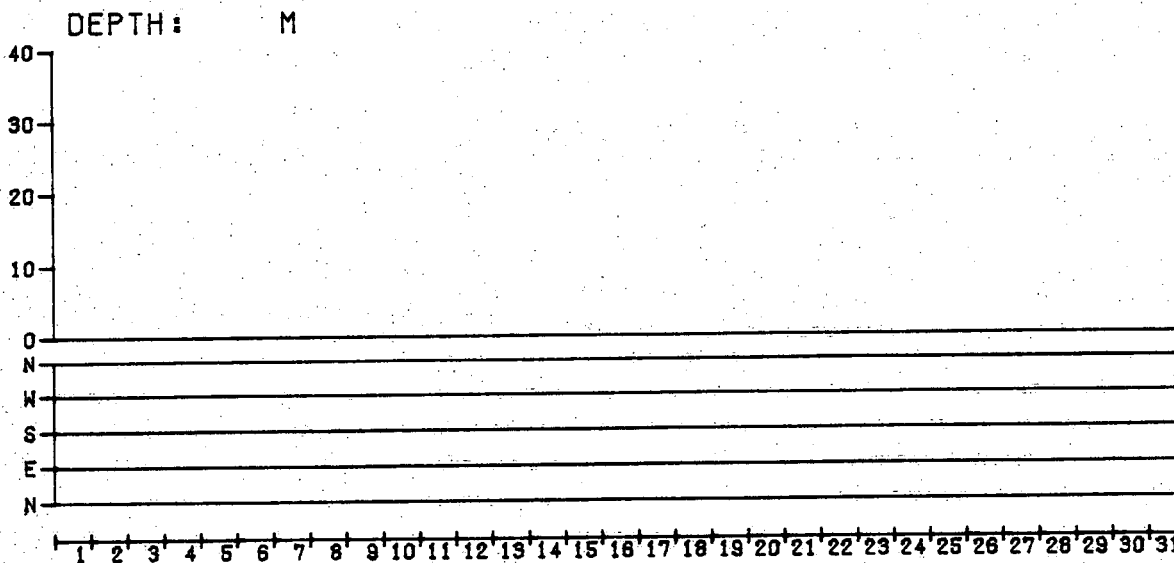
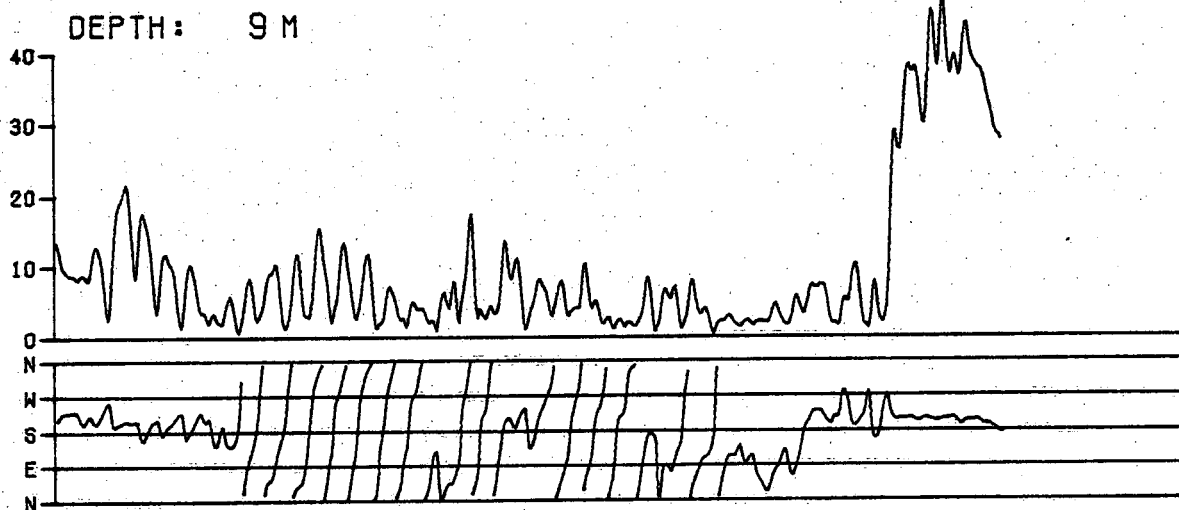



MOORING: 28

DATE: JULY 1973

TEMPERATURE °C

△ - 8 M  
○ - M

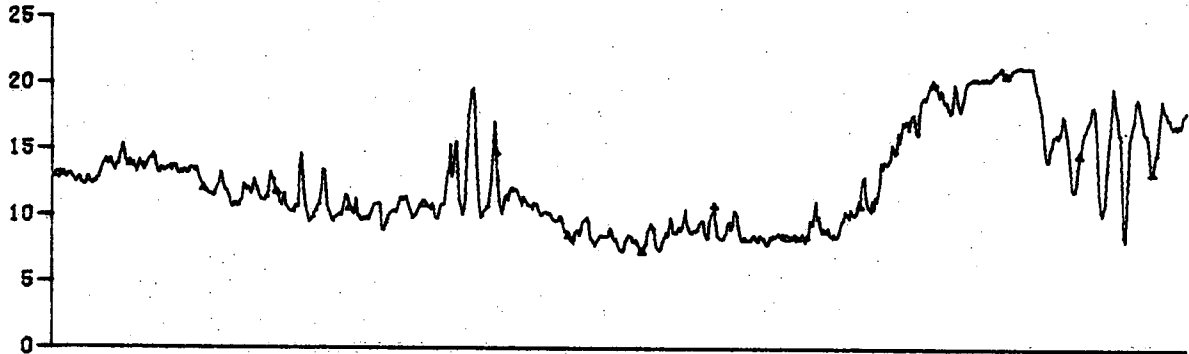

FILTERED CURRENT (0.0 TO 0.2 CPH) CM/SEC

DEPTH: 8 M

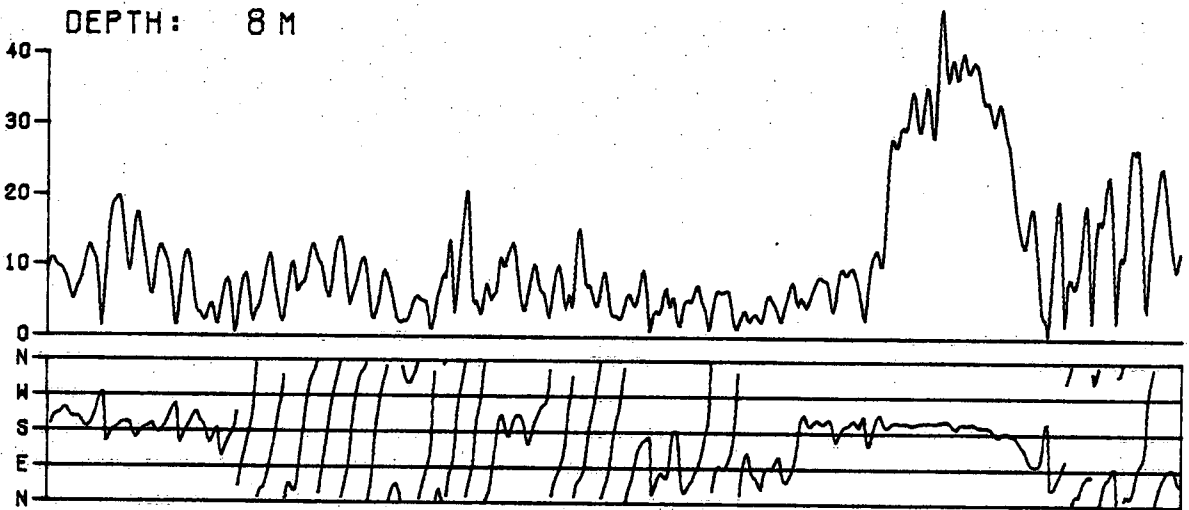

DEPTH: M

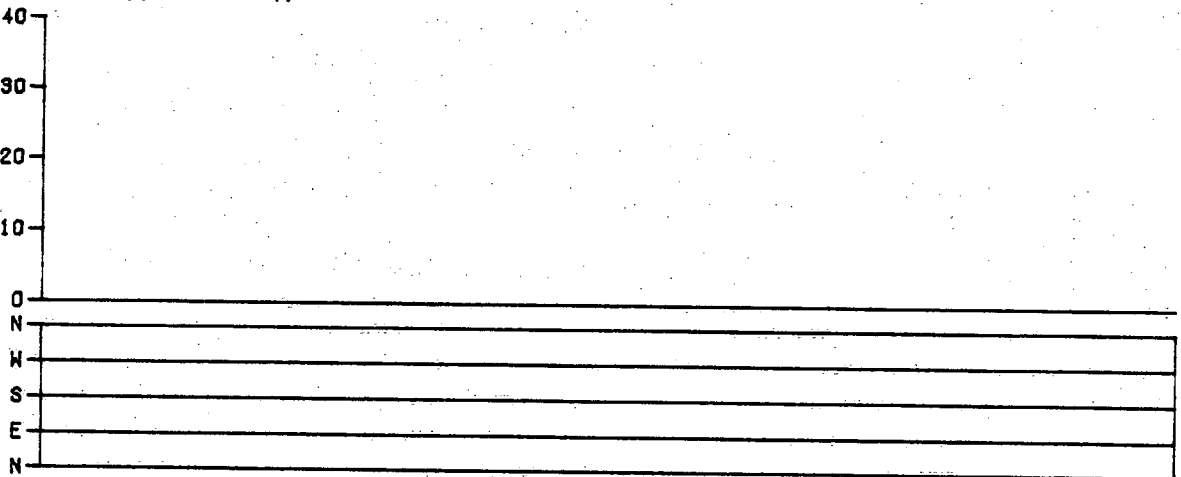

1 2 3 4 5 6 7 8 9 10 11 12 13 14 15 16 17 18 19 20 21 22 23 24 25 26 27 28 29 30 31

MOORING: 21

DATE: AUG 1973

TEMPERATURE °C

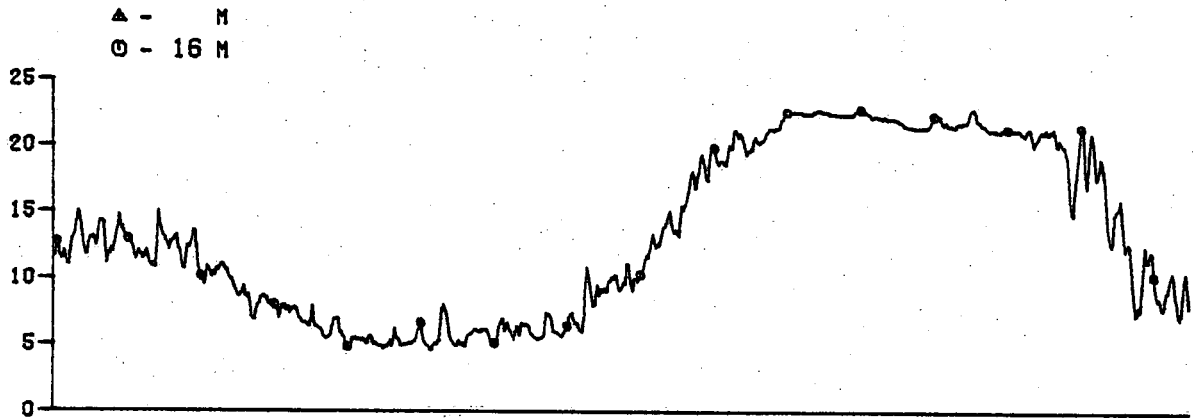

FILTERED CURRENT (0.0 TO 0.2 CPH) CM/SEC

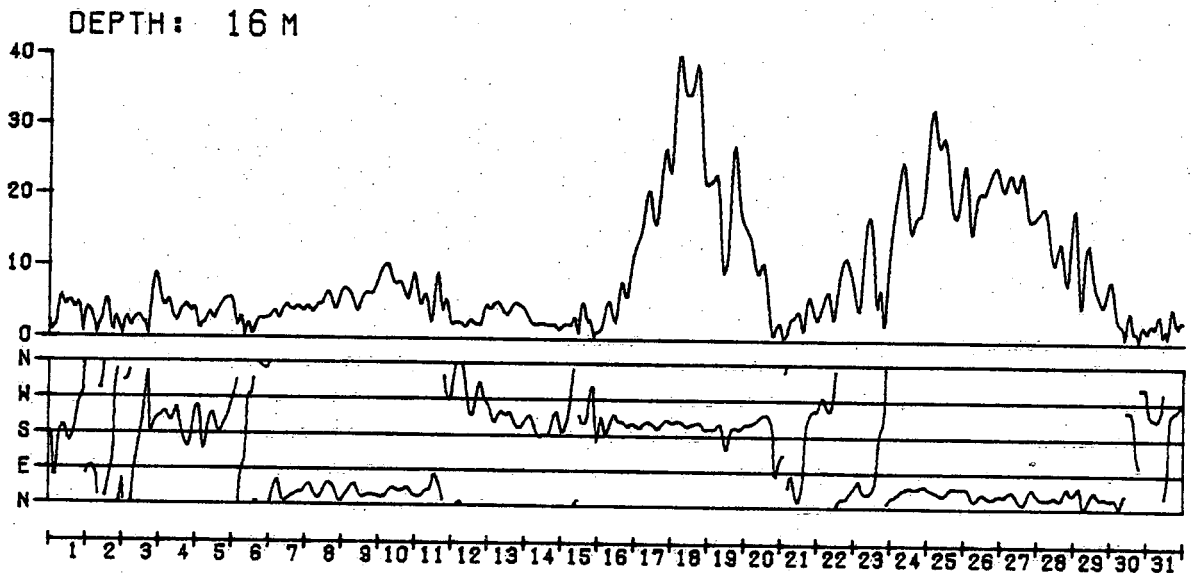
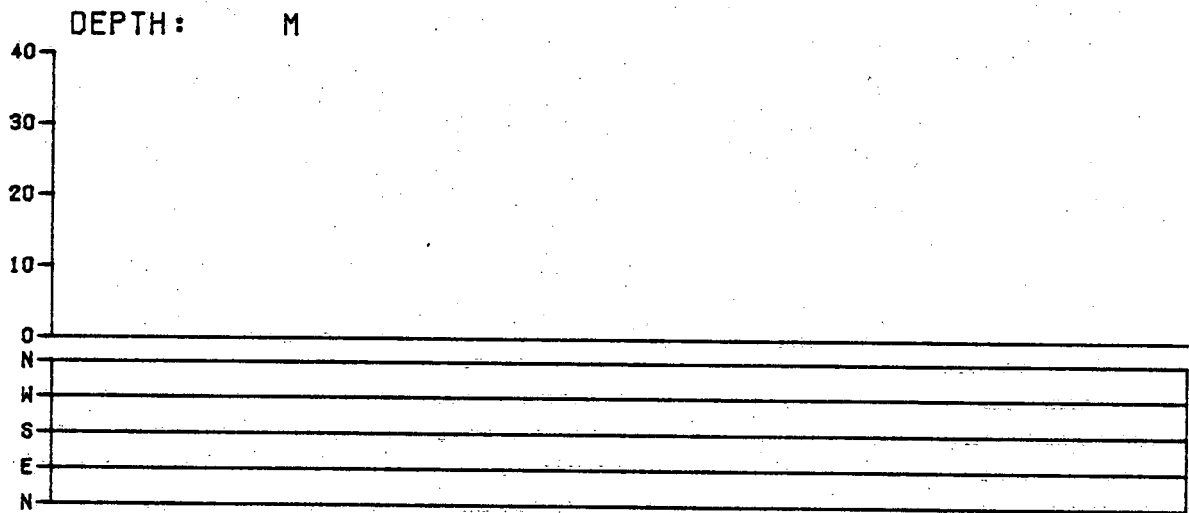

MOORING: 22

DATE: AUG 1973

TEMPERATURE °C

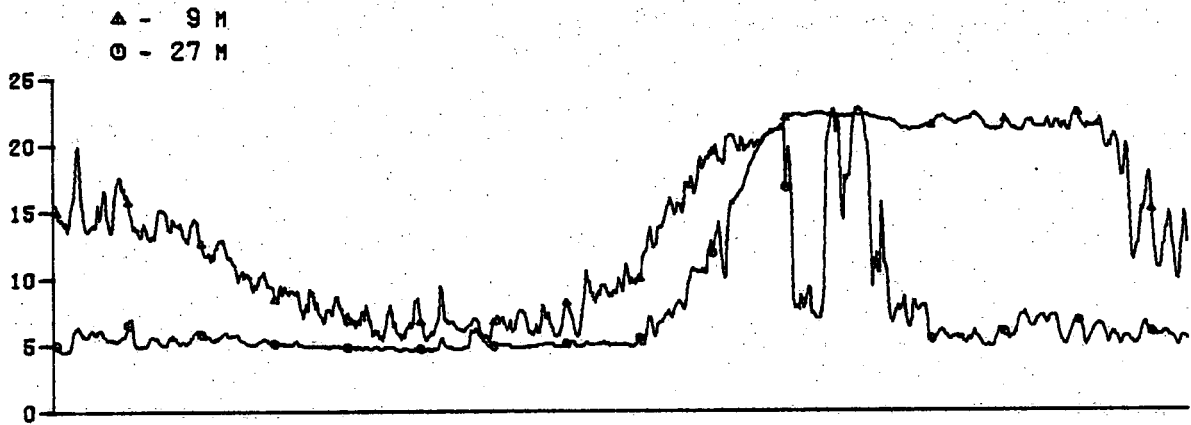

FILTERED CURRENT (0.0 TO 0.2 CPH) CM/SEC

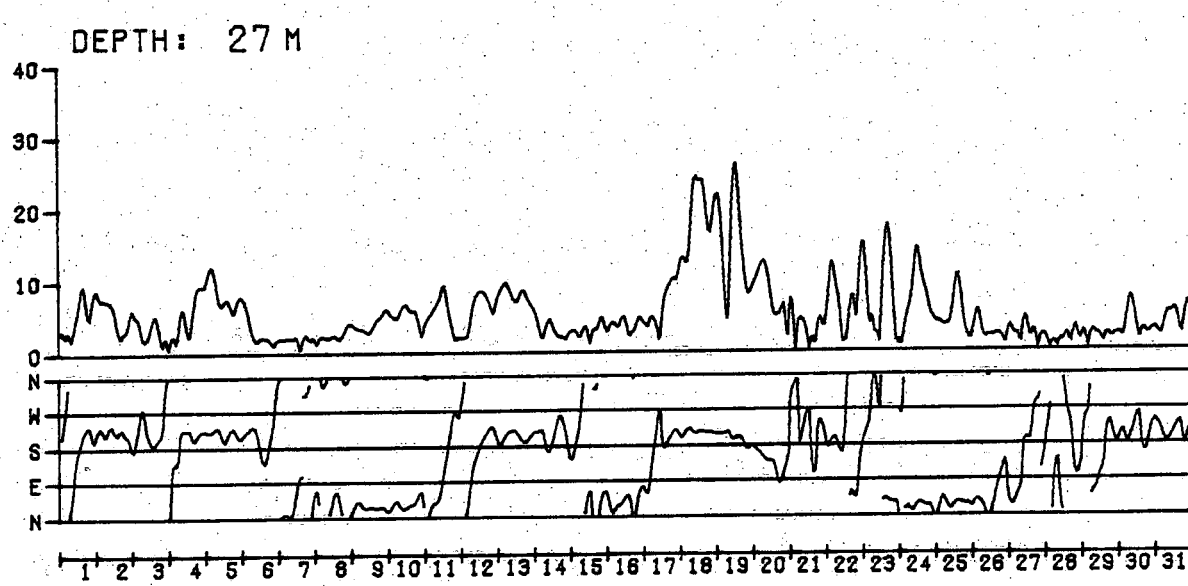
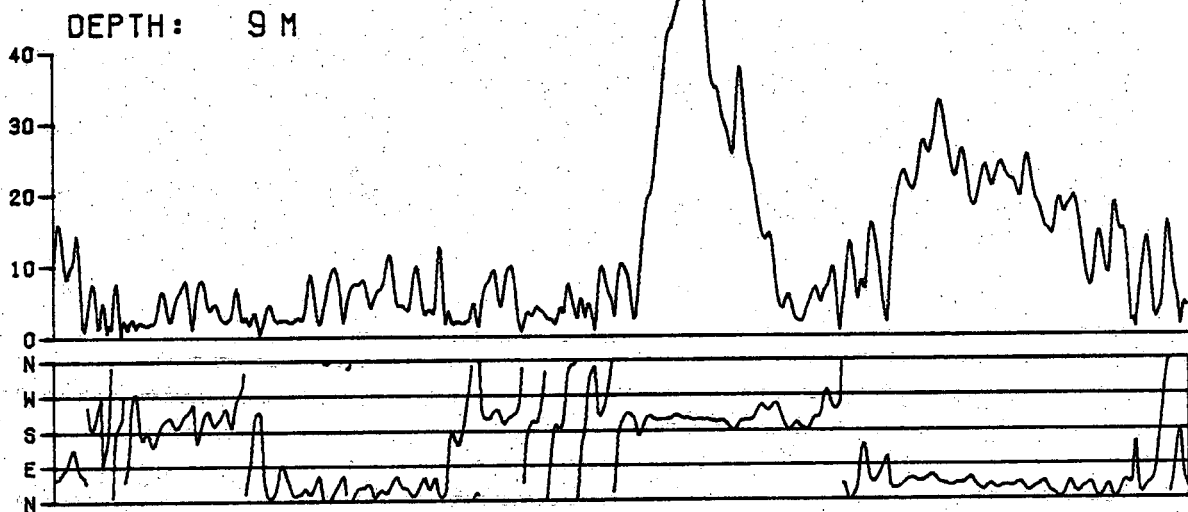

MOORING: 23

DATE: AUG 1973

TEMPERATURE °C

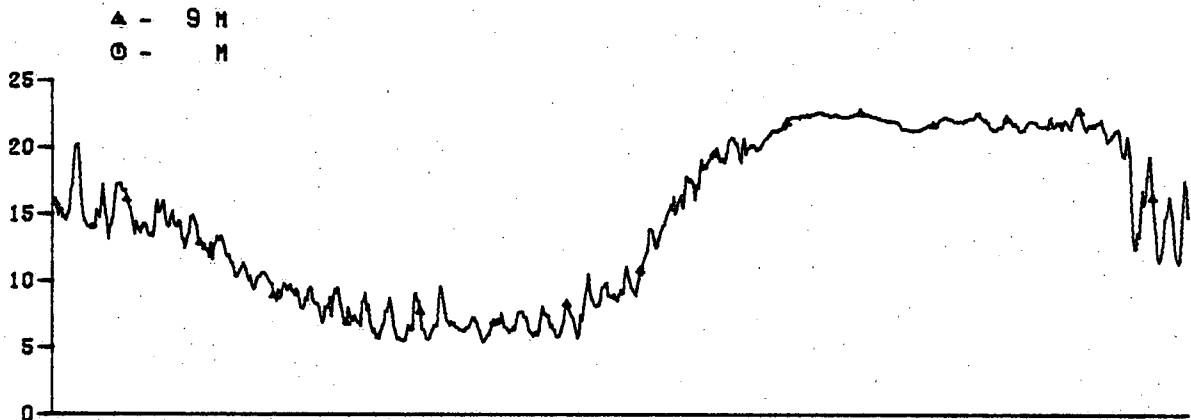

FILTERED CURRENT (0.0 TO 0.2 CPH) CM/SEC

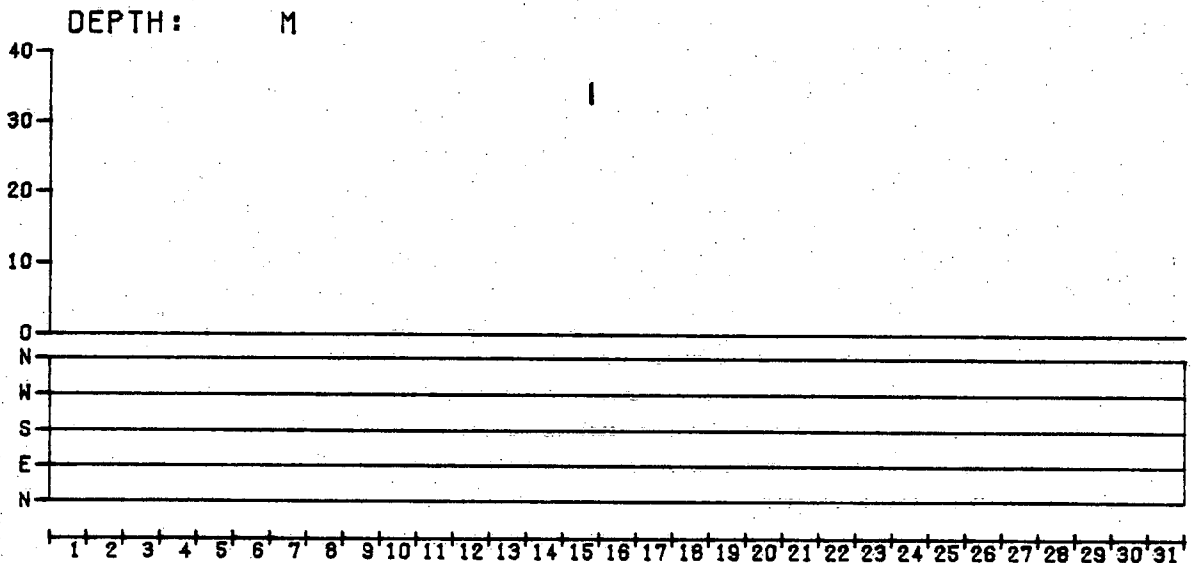
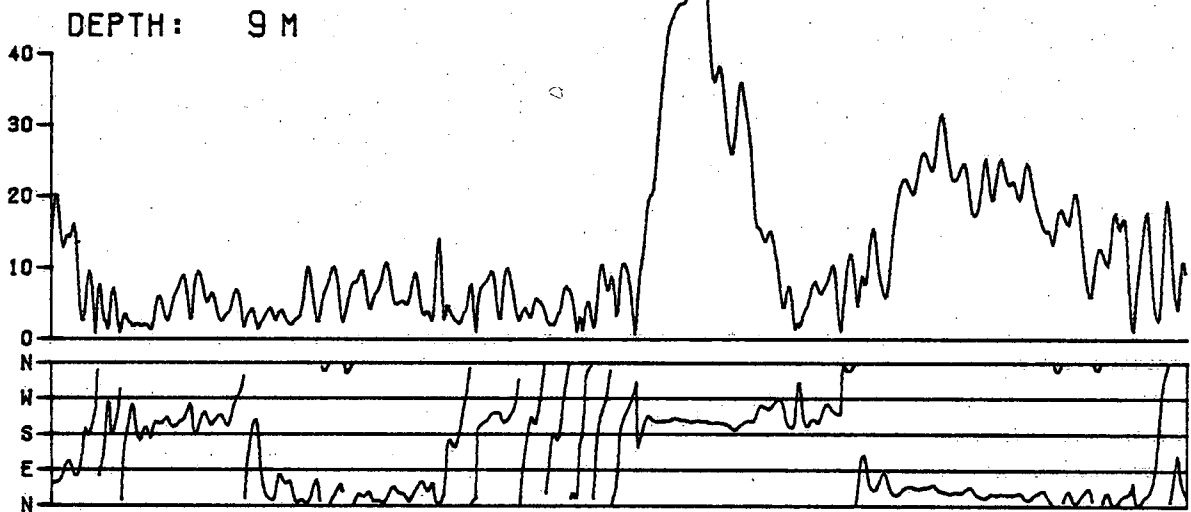

MOORING: 25

DATE: AUG 1973

TEMPERATURE °C

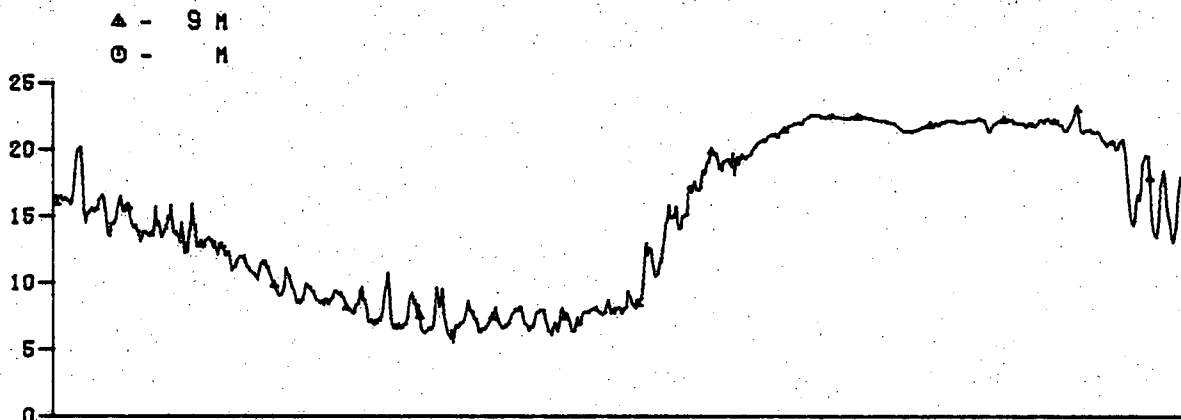

FILTERED CURRENT (0.0 TO 0.2 CPH) CM/SEC

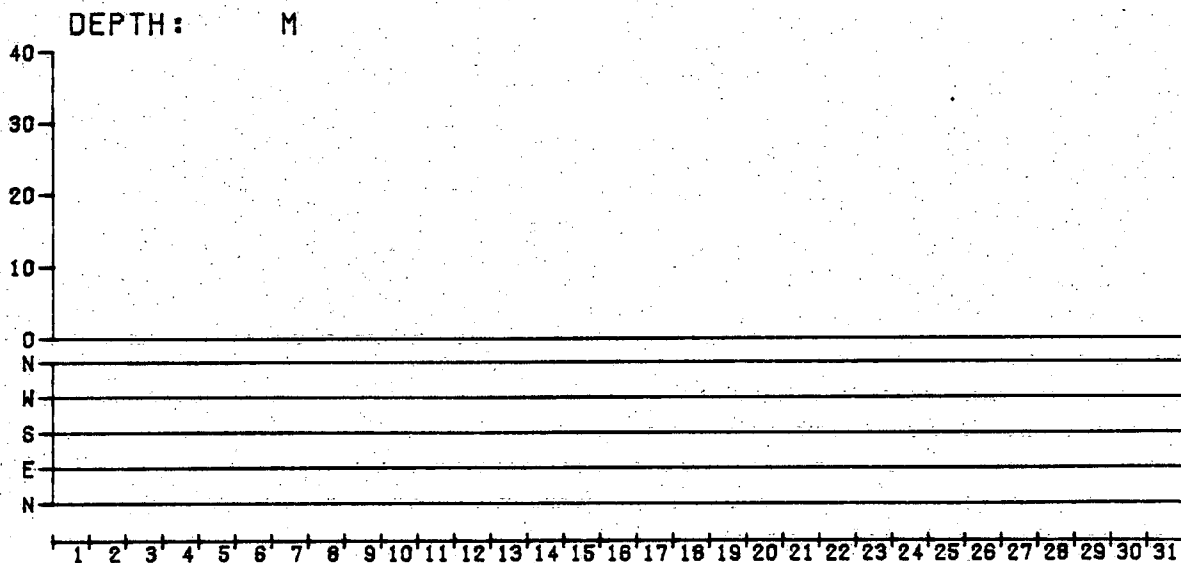
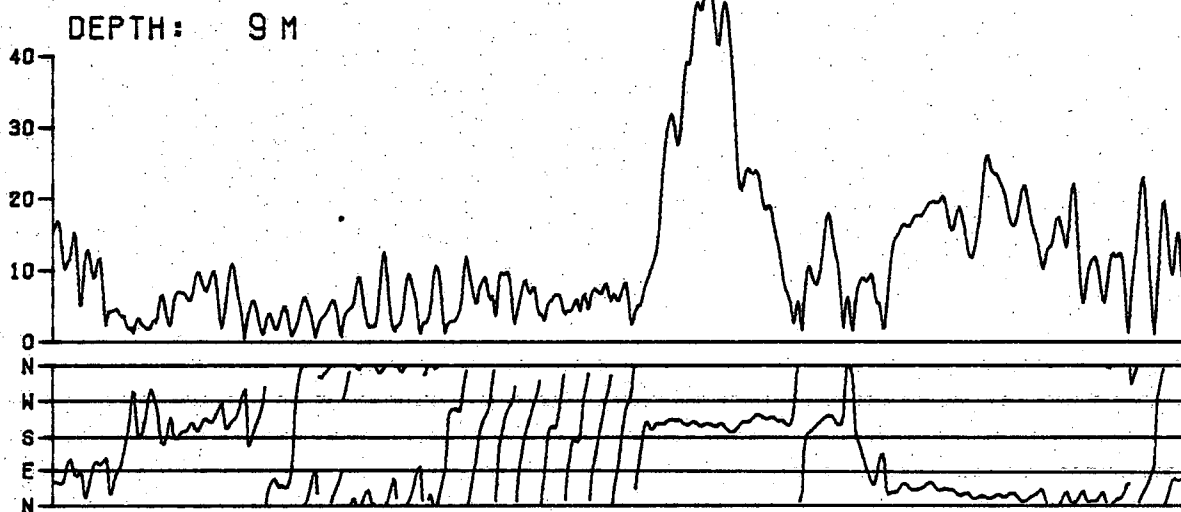

MOORING: 26

DATE: AUG 1973

TEMPERATURE °C

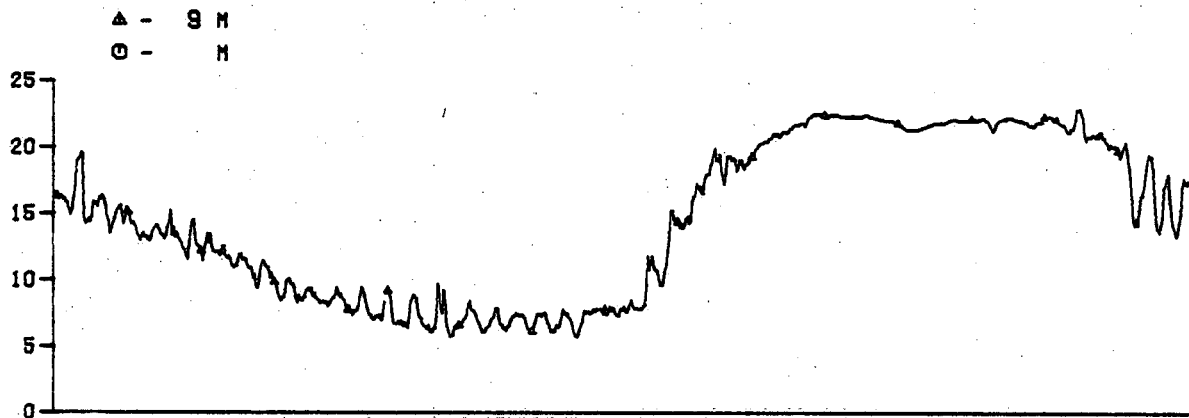

FILTERED CURRENT (0.0 TO 0.2 CPH) CM/SEC

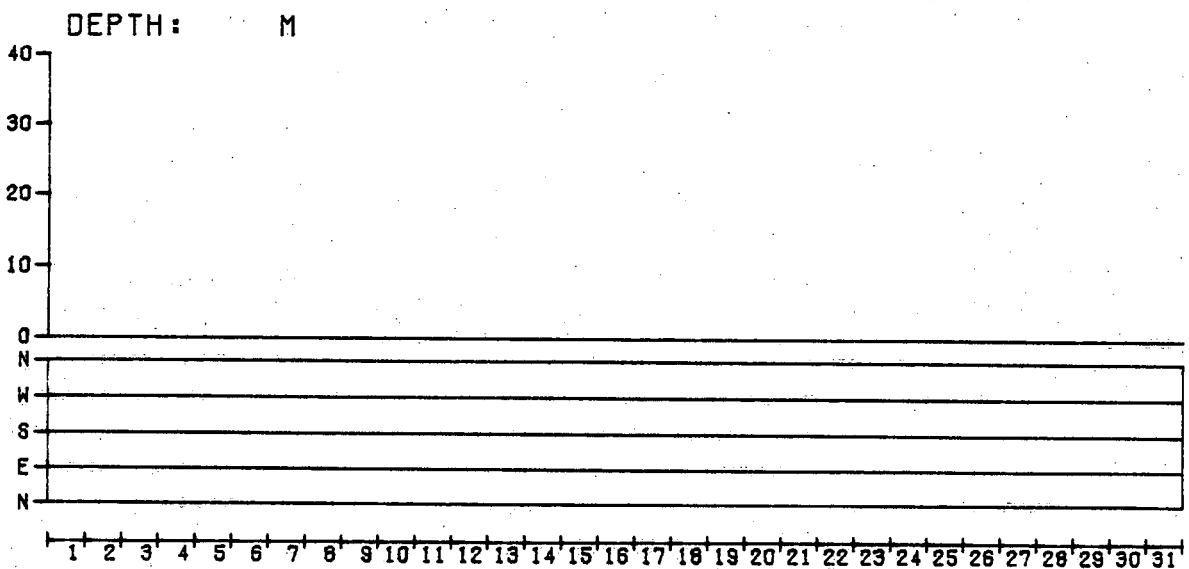
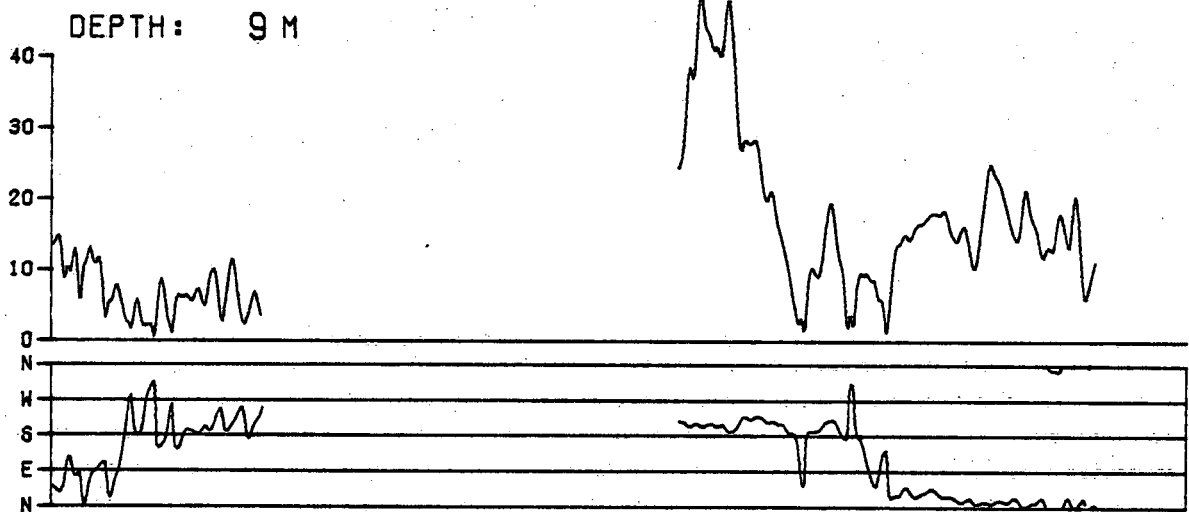

MOORING: 27

DATE: AUG 1973

TEMPERATURE °C

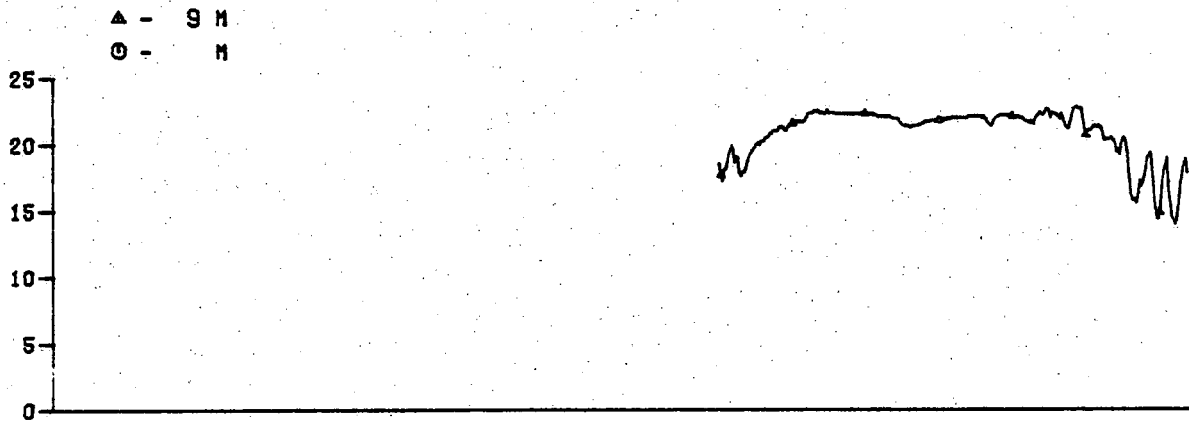

FILTERED CURRENT (0.0 TO 0.2 CPH) CM/SEC

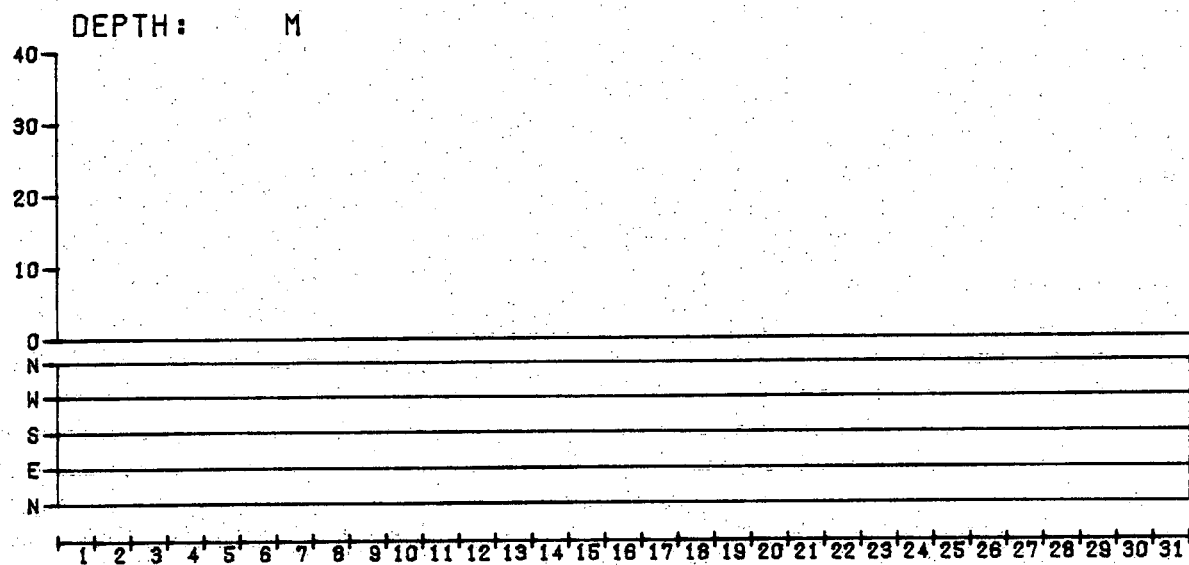
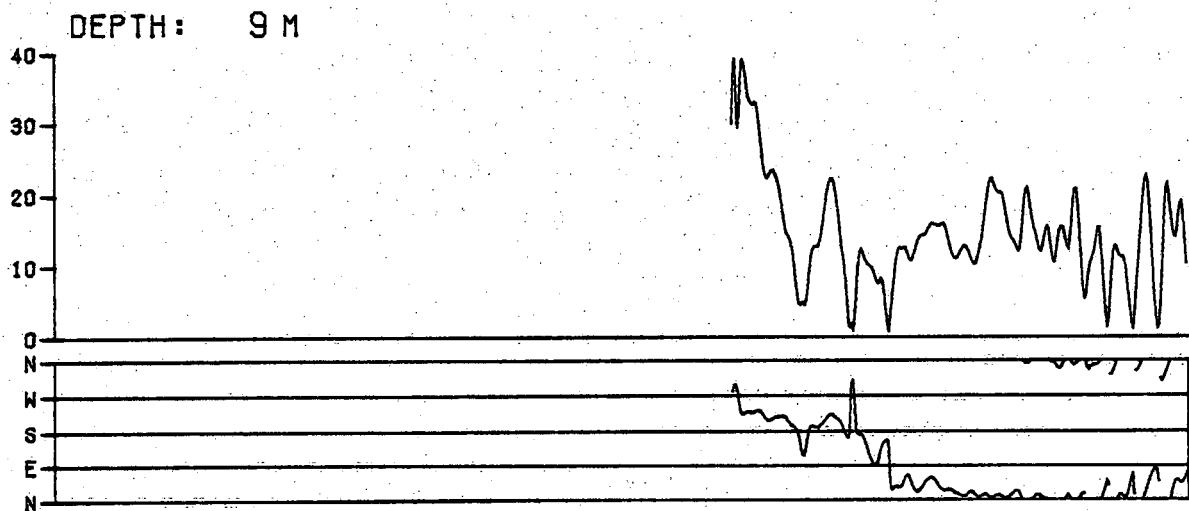

MOORING : 28

DATE : AUG 1973

TEMPERATURE °C

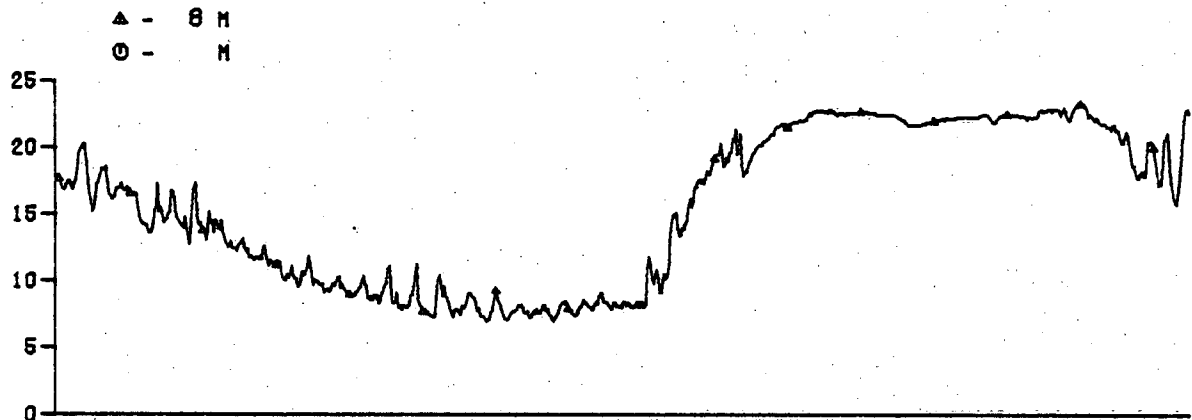

FILTERED CURRENT (0.0 TO 0.2 CPH) CM/SEC

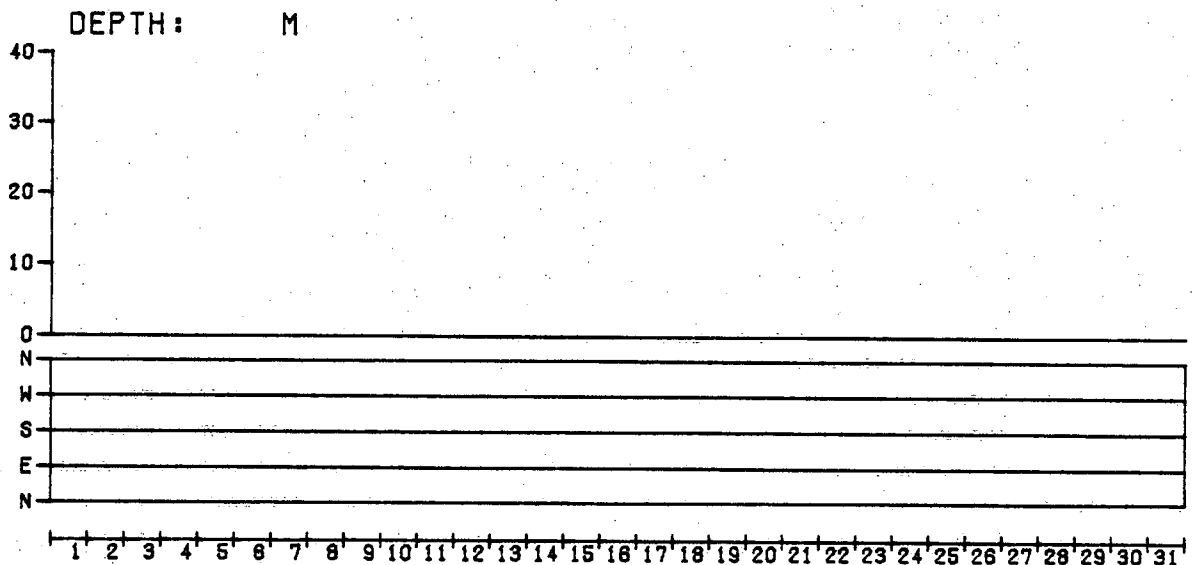
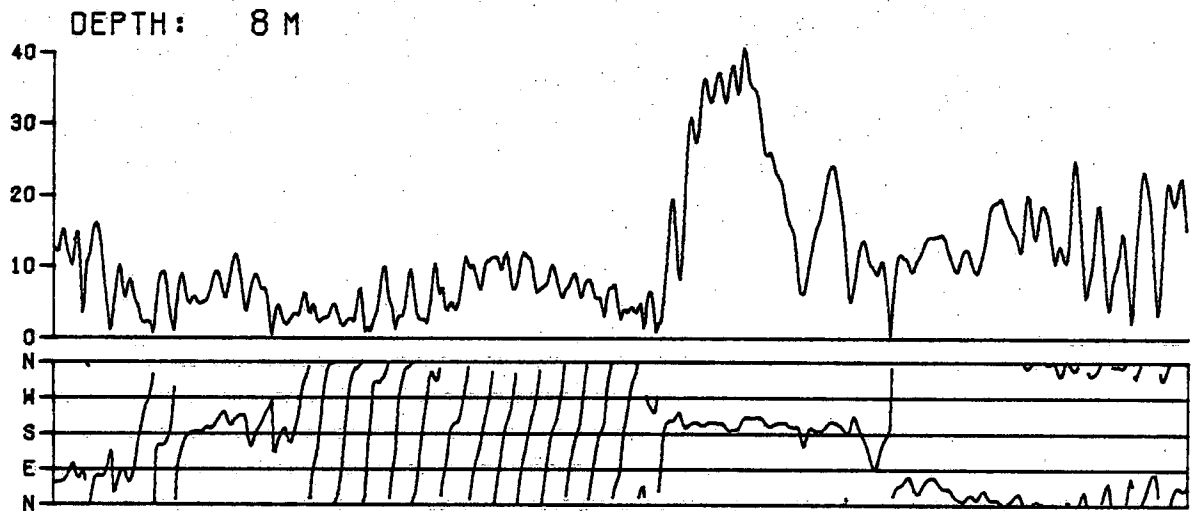



MOORING: 21

DATE: SEPT 1973

TEMPERATURE °C

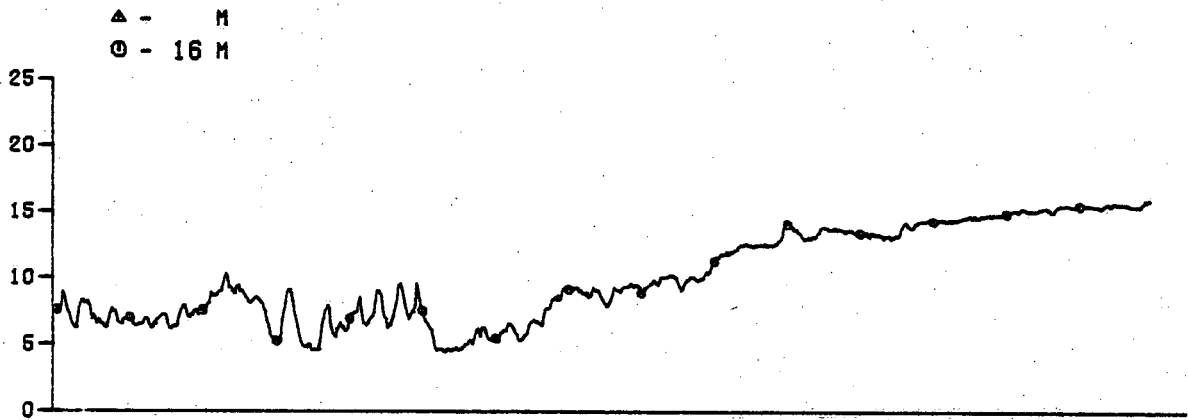

FILTERED CURRENT (0.0 TO 0.2 CPH) CM/SEC

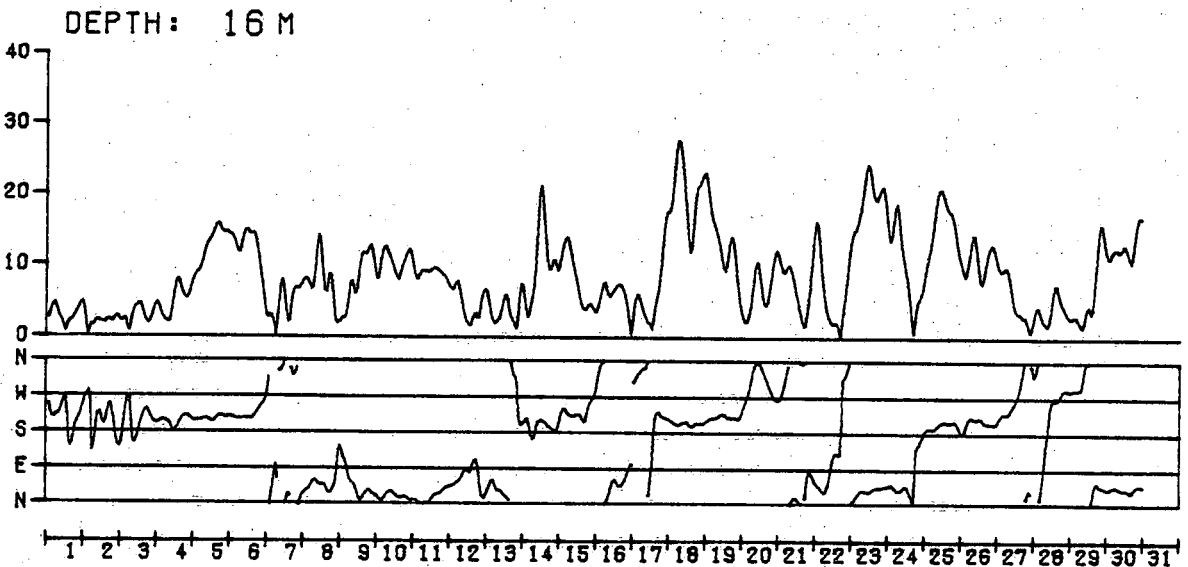
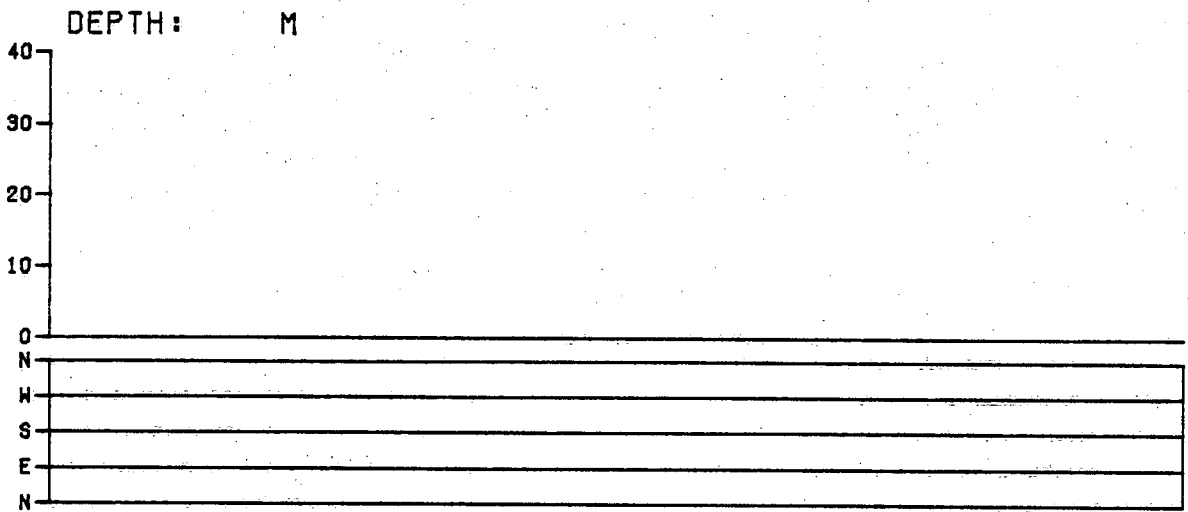

MOORING : 22

DATE : SEPT 1973

TEMPERATURE °C

△ - 9 M  
⊙ - 27 M

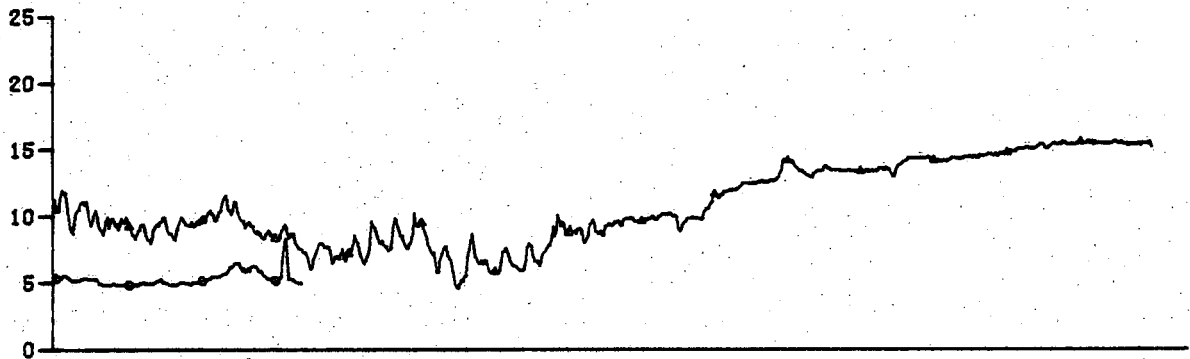

FILTERED CURRENT (0.0 TO 0.2 CPH) CM/SEC

DEPTH: 9 M

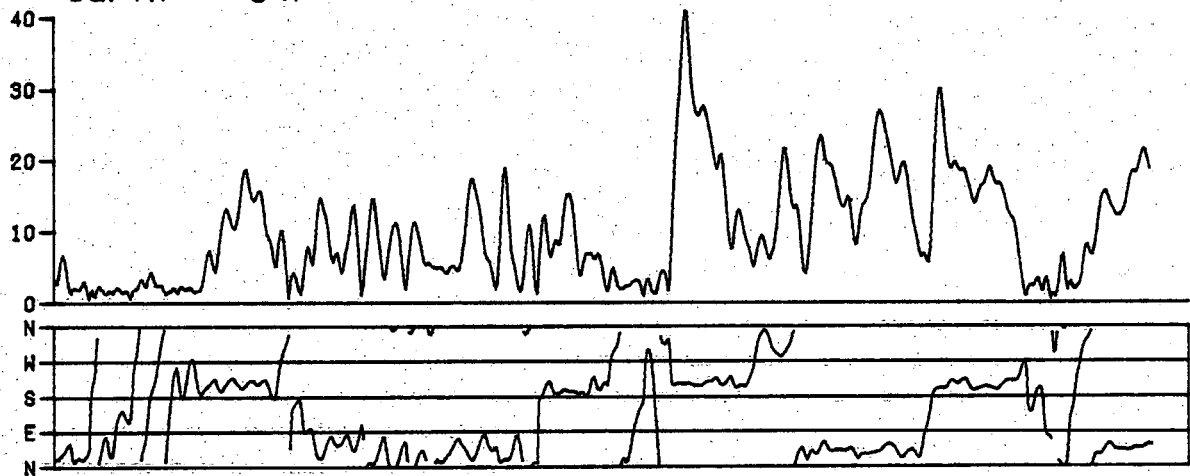

DEPTH: 27 M

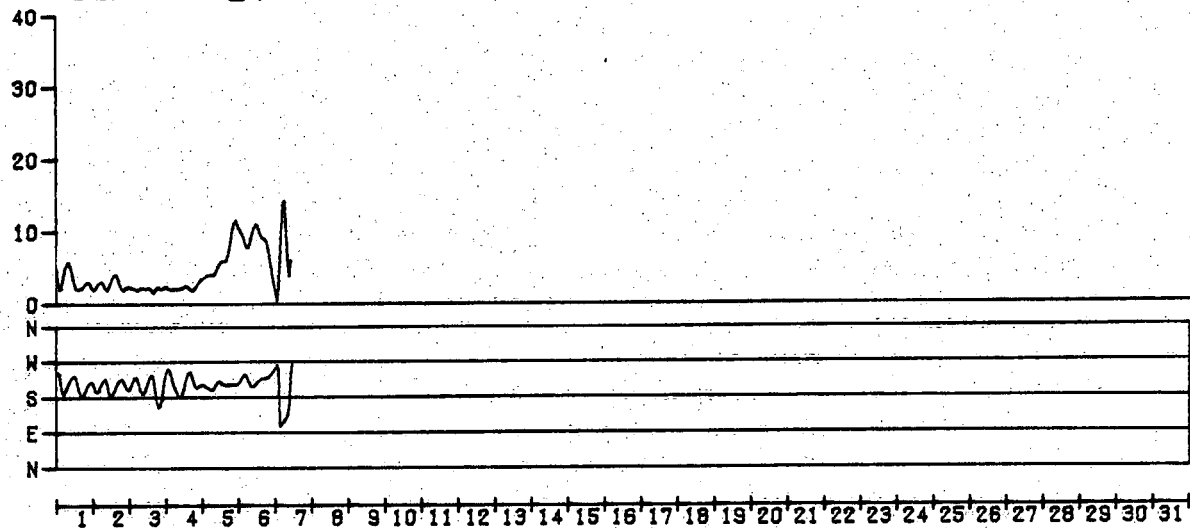

MOORING : 23

DATE : SEPT 1973

TEMPERATURE °C

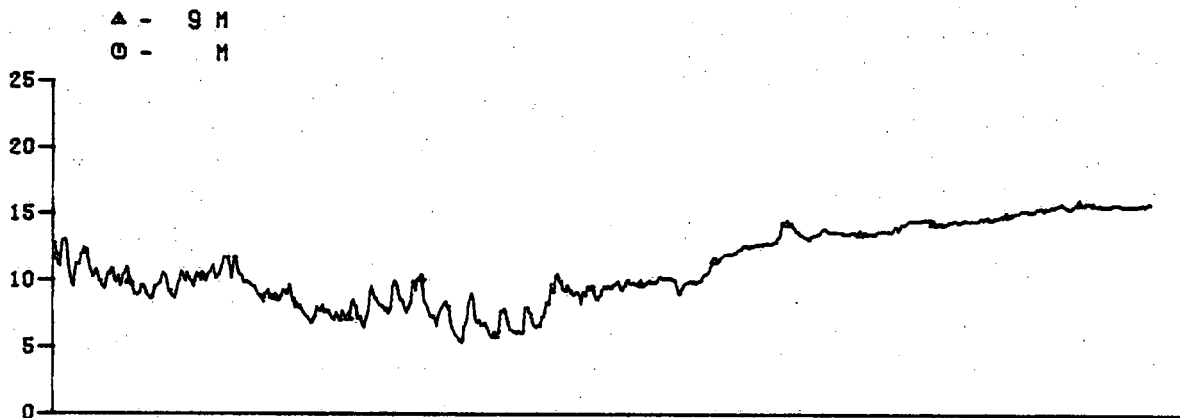

FILTERED CURRENT (0.0 TO 0.2 CPH) CM/SEC

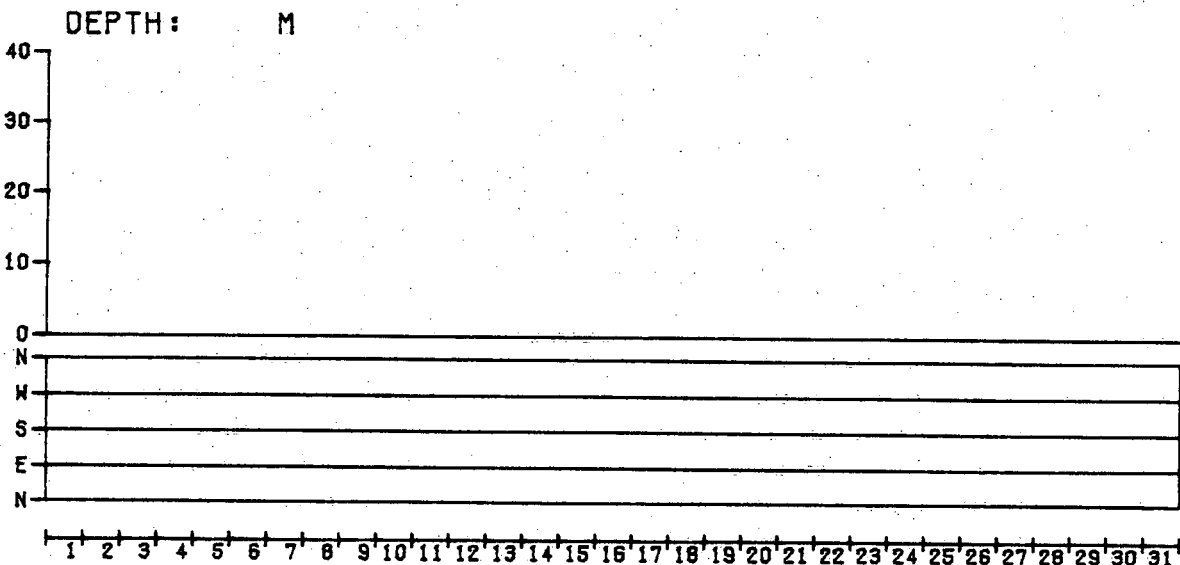
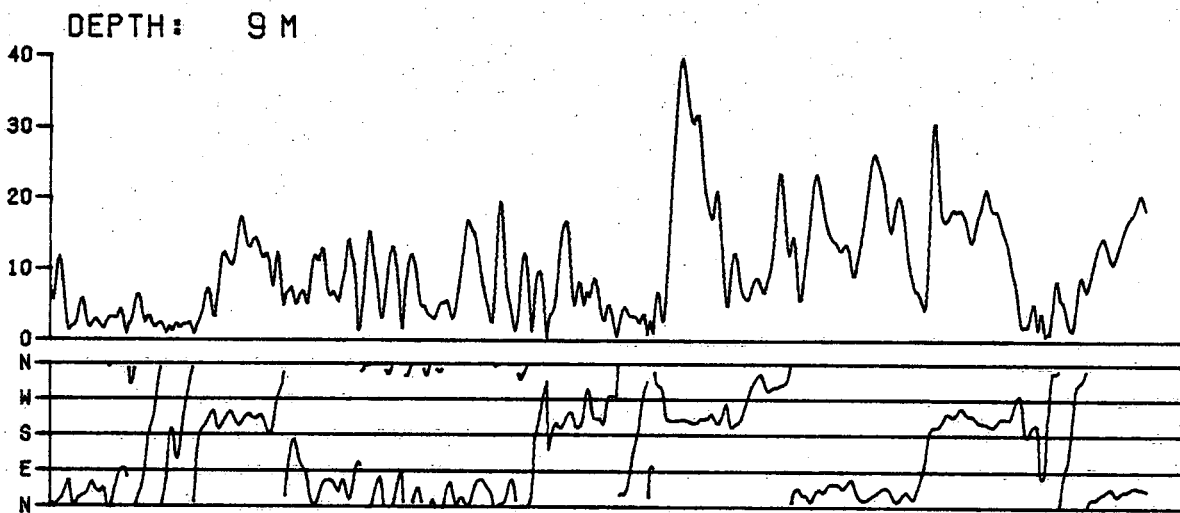

MOORING: 25

DATE: SEPT 1973

TEMPERATURE °C

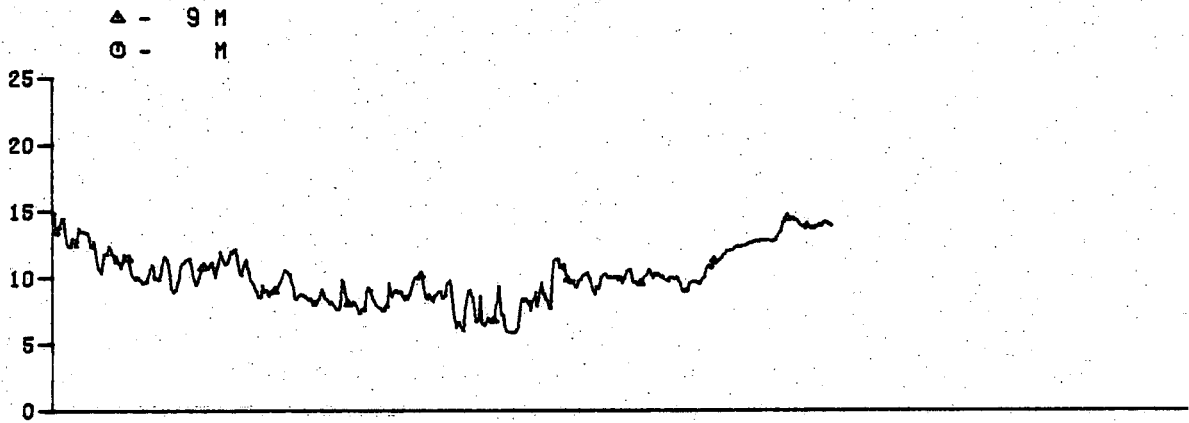

FILTERED CURRENT (0.0 TO 0.2 CPH) CM/SEC

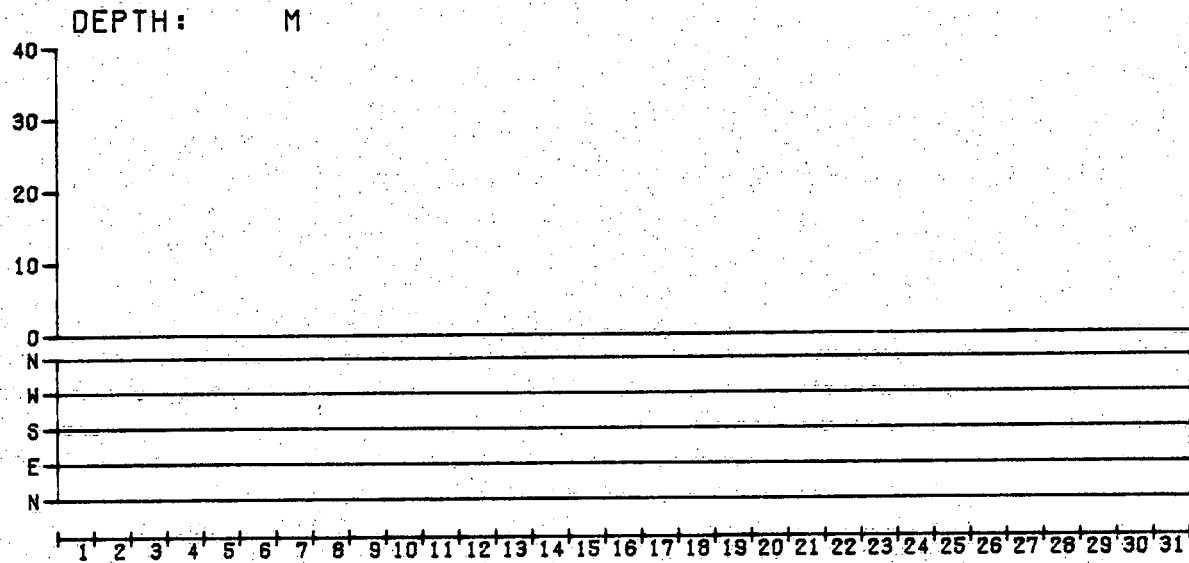
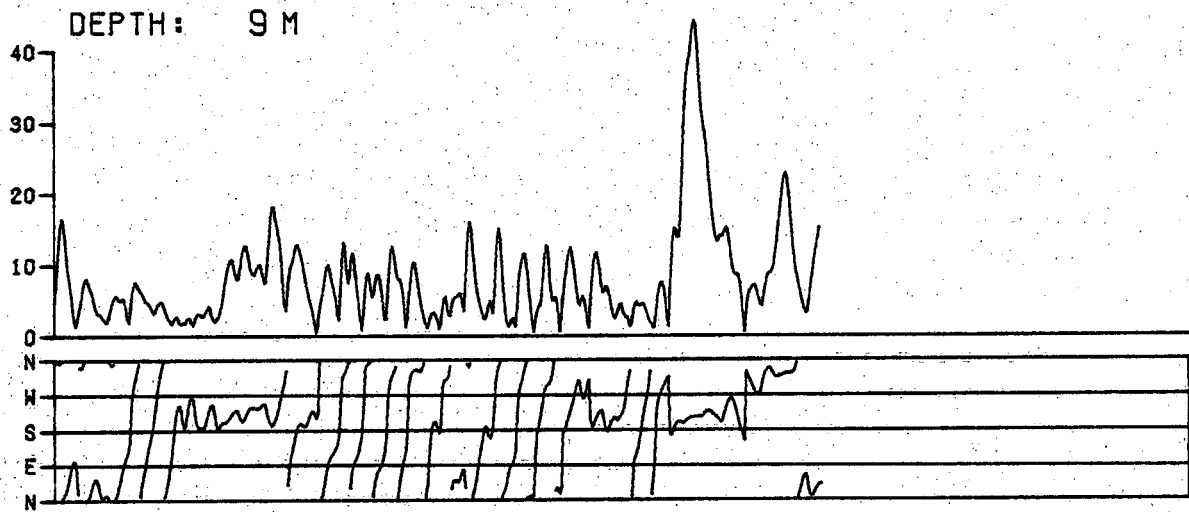

MOORING: 27

DATE: SEPT 1973

TEMPERATURE °C

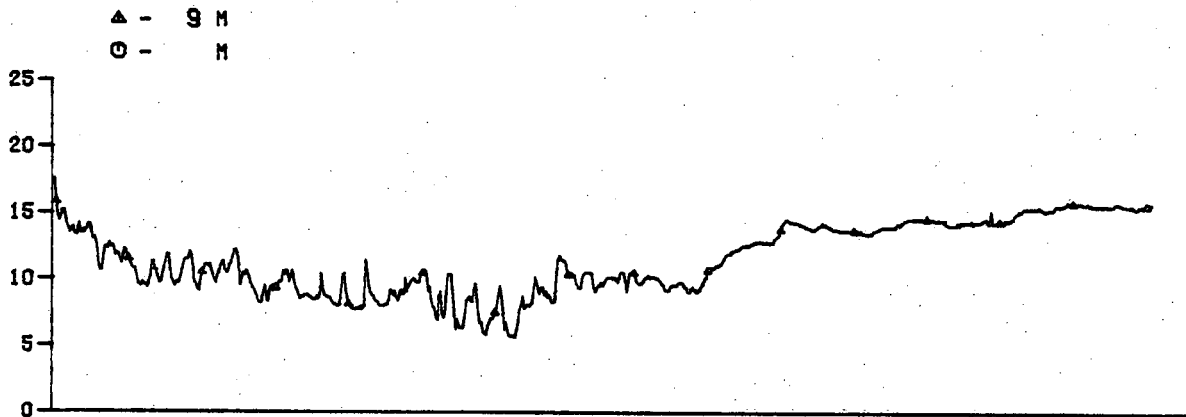

FILTERED CURRENT (0.0 TO 0.2 CPH) CM/SEC

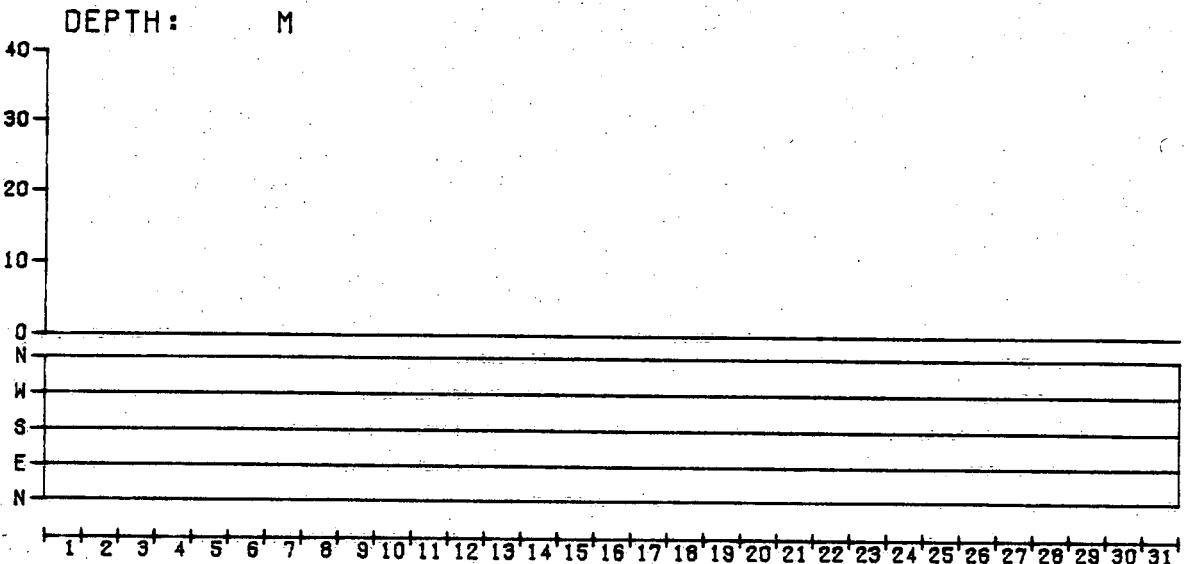
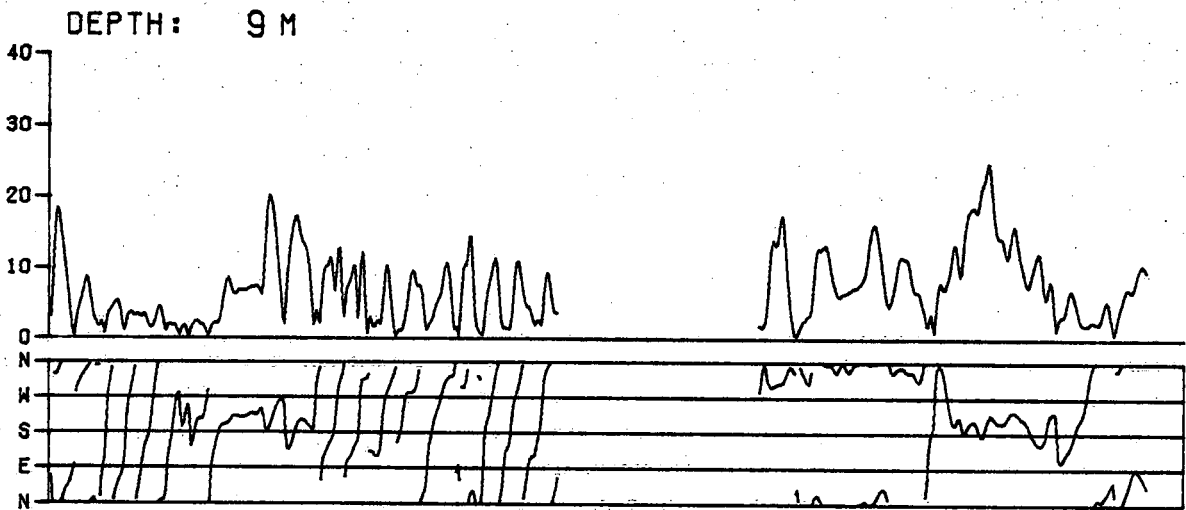

MOORING : 28

DATE : SEPT 1973

TEMPERATURE °C

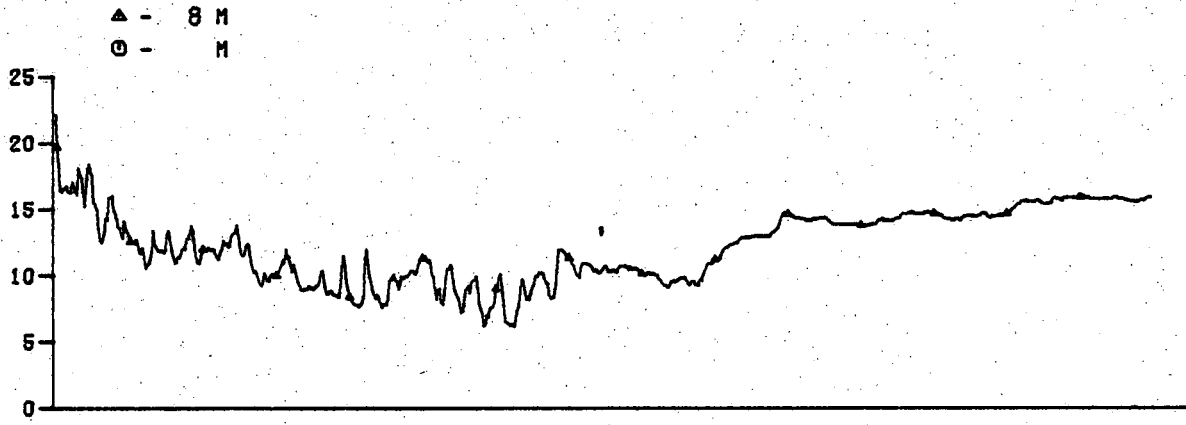

FILTERED CURRENT (0.0 TO 0.2 CPH) CM/SEC

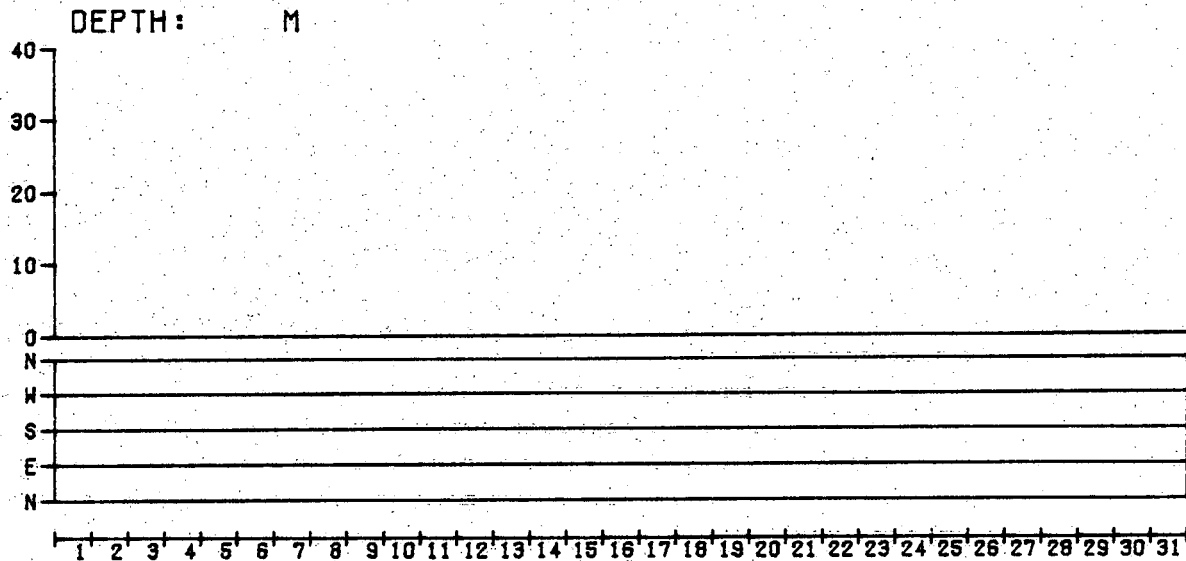
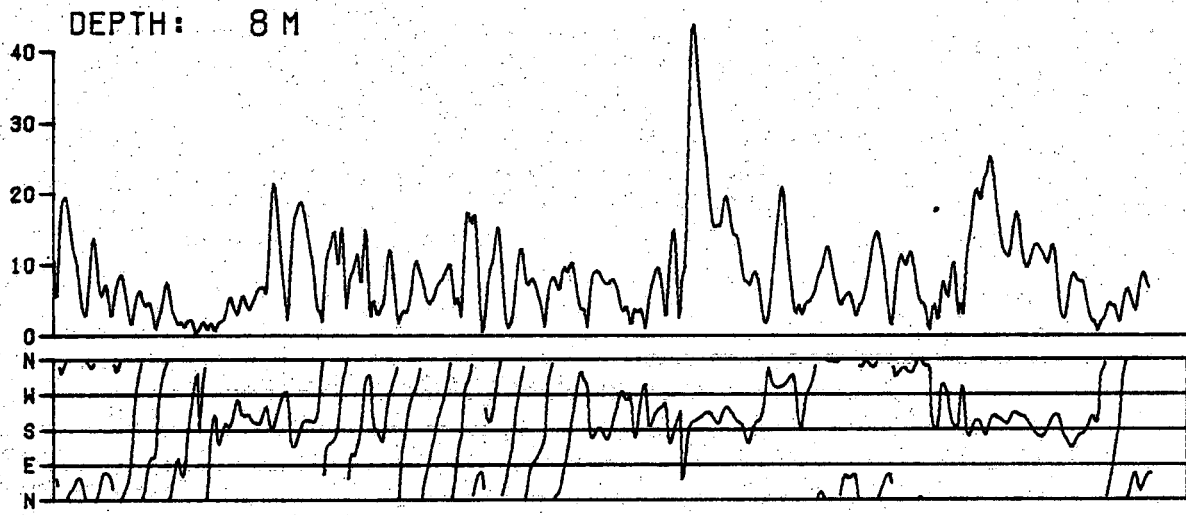

MOORING : 22

DATE : OCT 1973

TEMPERATURE °C

△ - 9 M  
○ - M

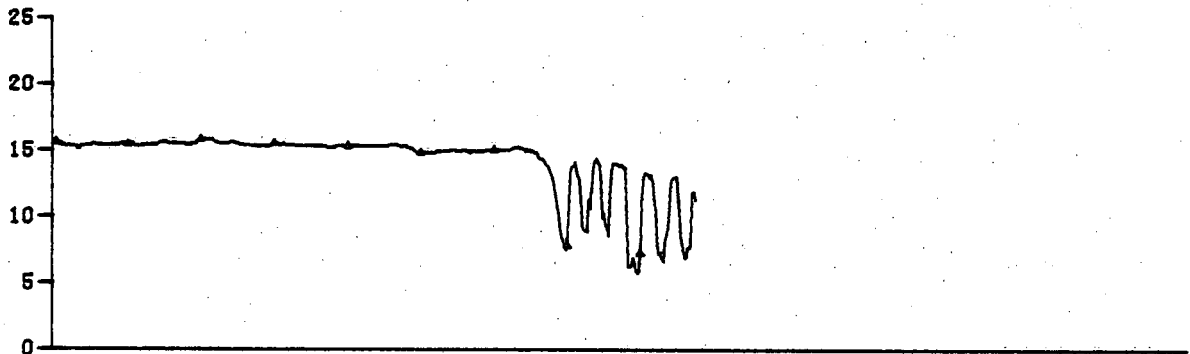

FILTERED CURRENT (0.0 TO 0.2 CPH) CM/SEC

DEPTH: 9 M

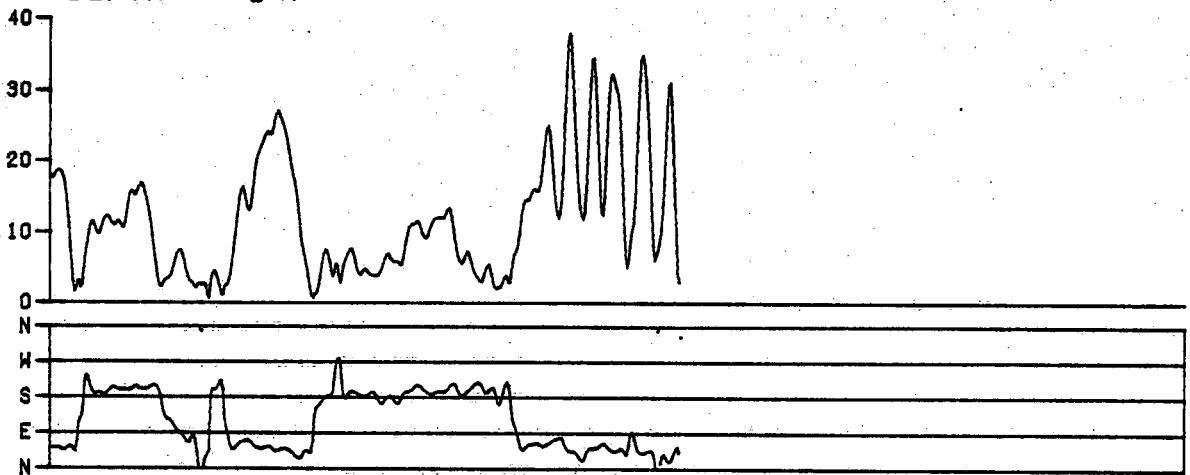

DEPTH: M

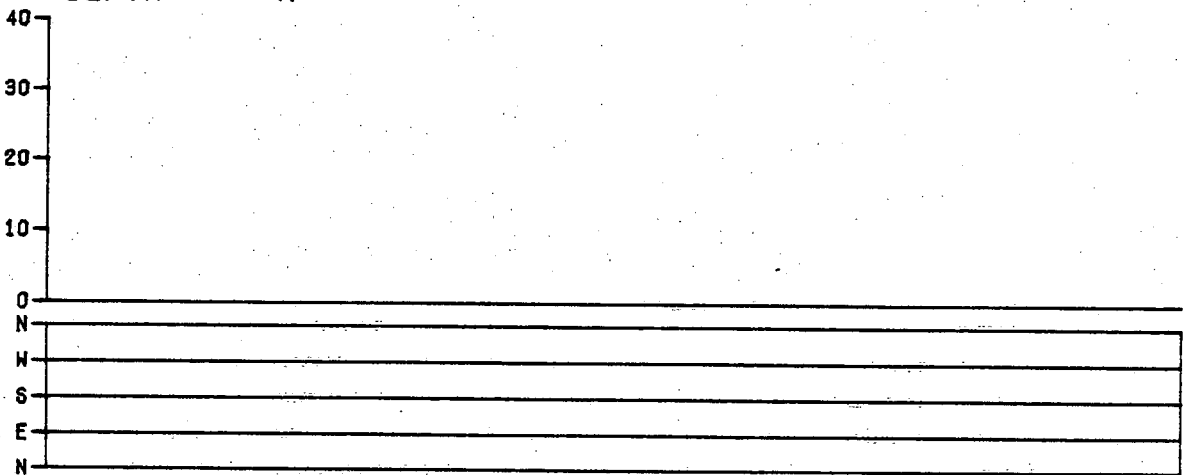

1' 2' 3' 4' 5' 6' 7' 8' 9' 10' 11' 12' 13' 14' 15' 16' 17' 18' 19' 20' 21' 22' 23' 24' 25' 26' 27' 28' 29' 30' 31'

MOORING: 23

DATE: OCT 1973

TEMPERATURE °C

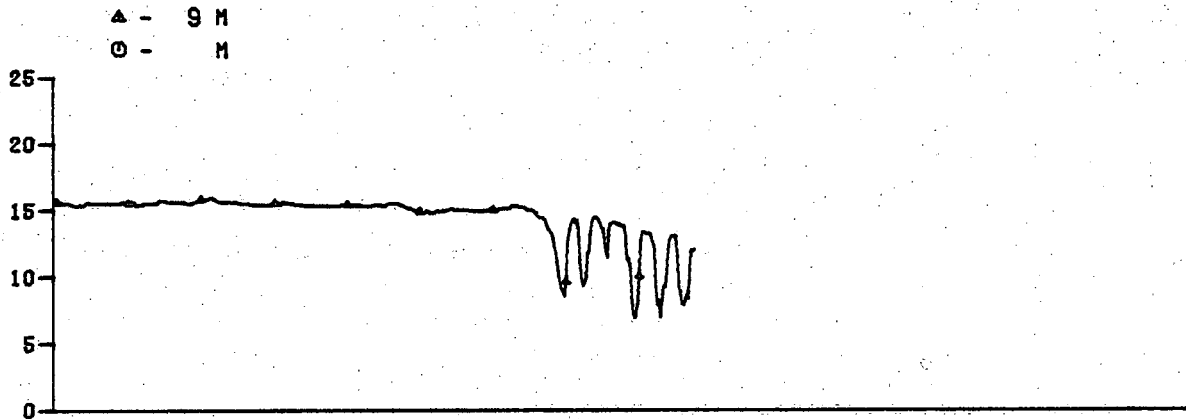

FILTERED CURRENT (0.0 TO 0.2 CPH) CM/SEC

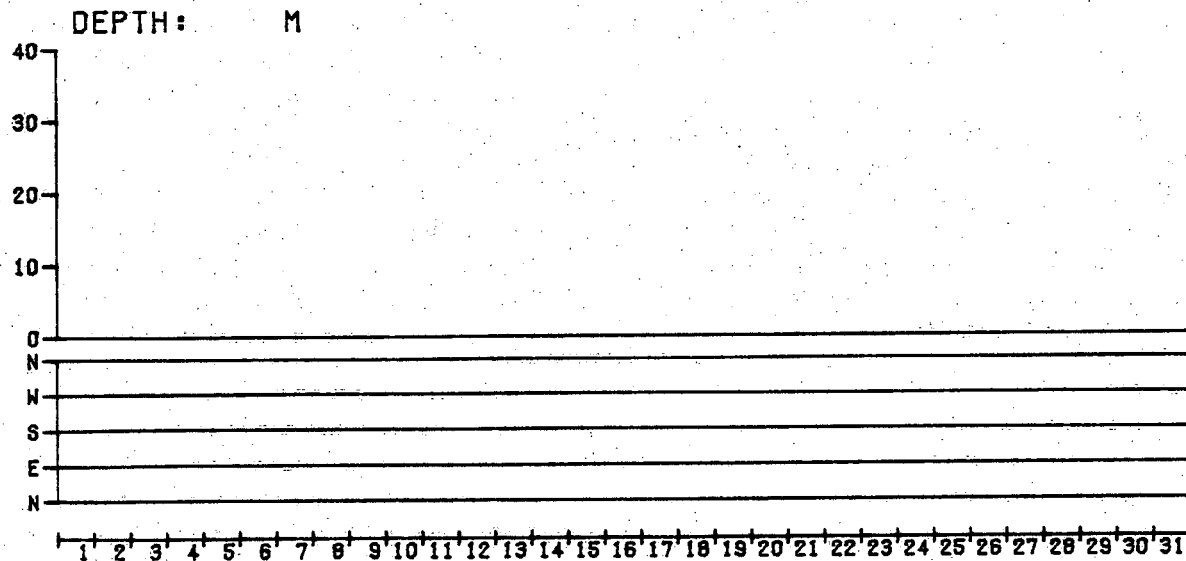
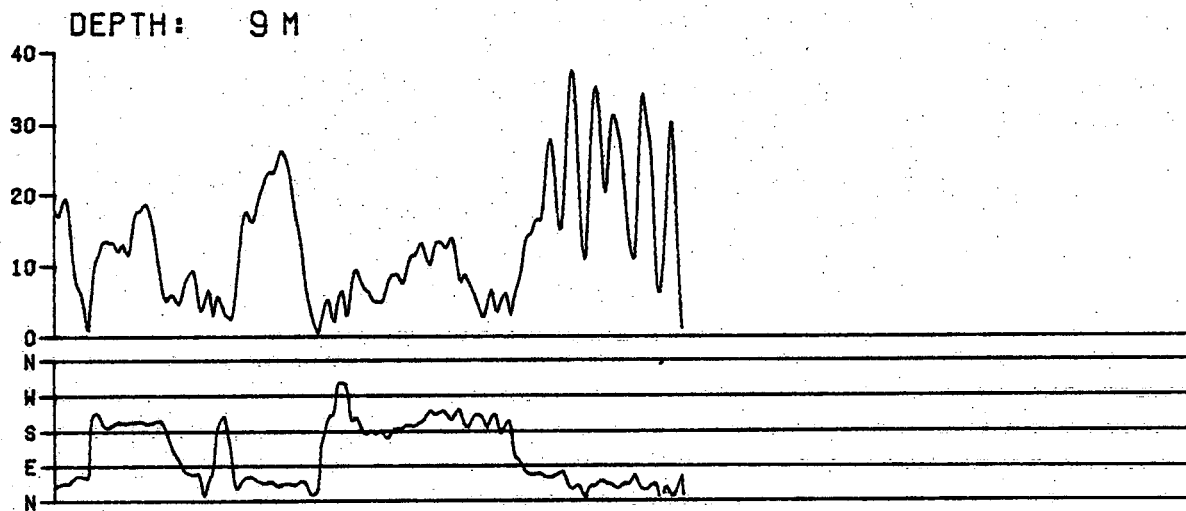



MOORING: 27

DATE: OCT 1973

TEMPERATURE °C

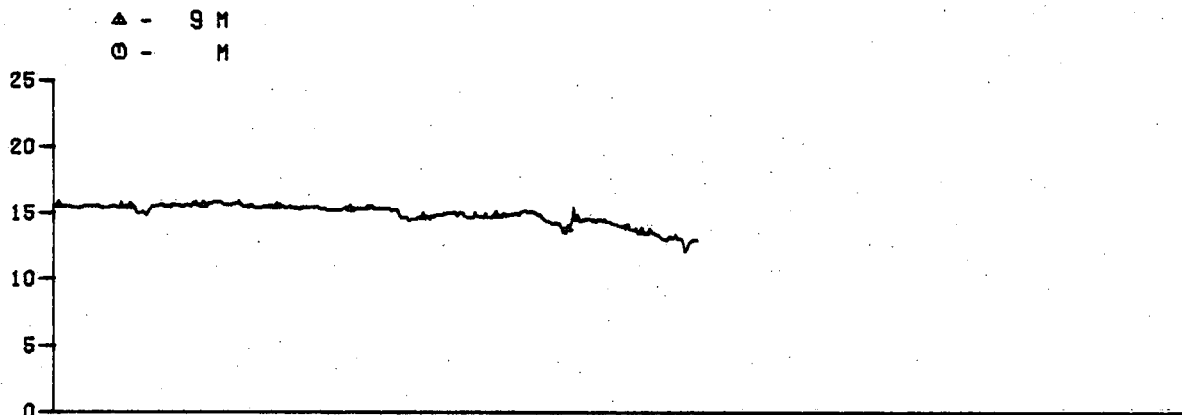

FILTERED CURRENT (0.0 TO 0.2 CPH) CM/SEC

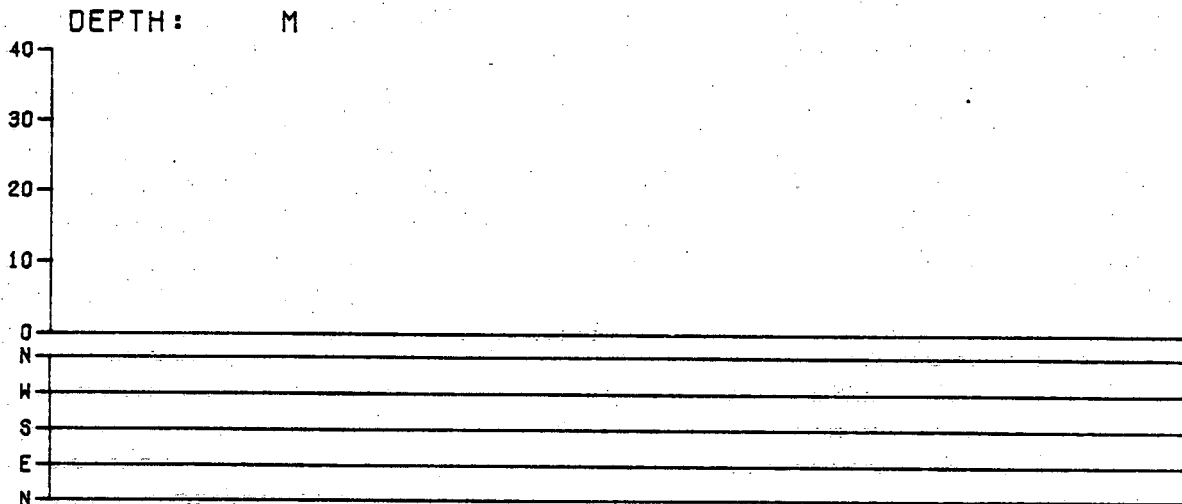
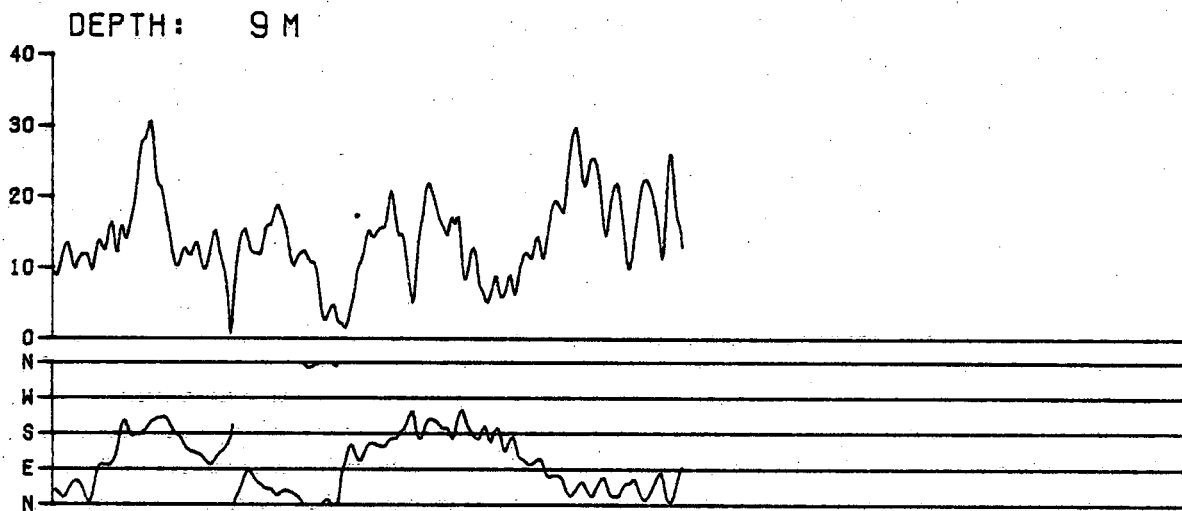

1 2 3 4 5 6 7 8 9 10 11 12 13 14 15 16 17 18 19 20 21 22 23 24 25 26 27 28 29 30 31

MOORING: 28

DATE: OCT 1973

TEMPERATURE °C

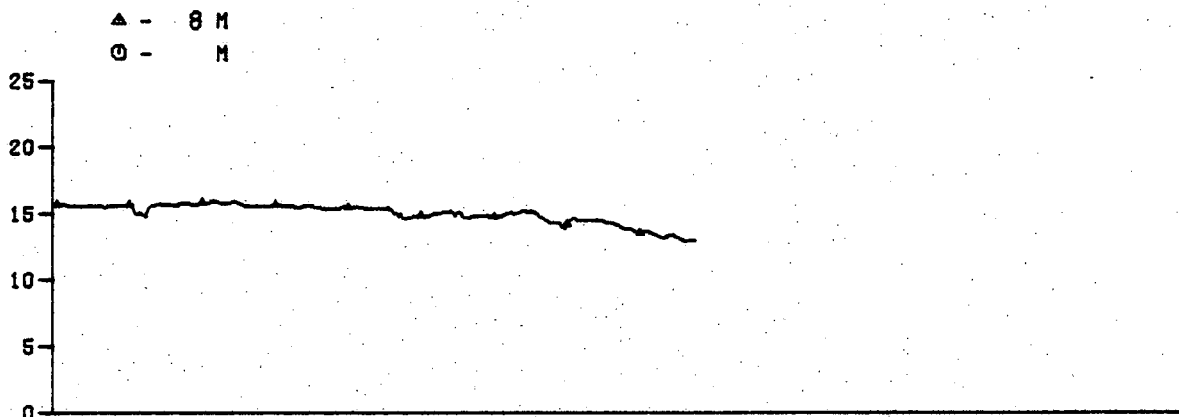

FILTERED CURRENT (0.0 TO 0.2 CPH) CM/SEC

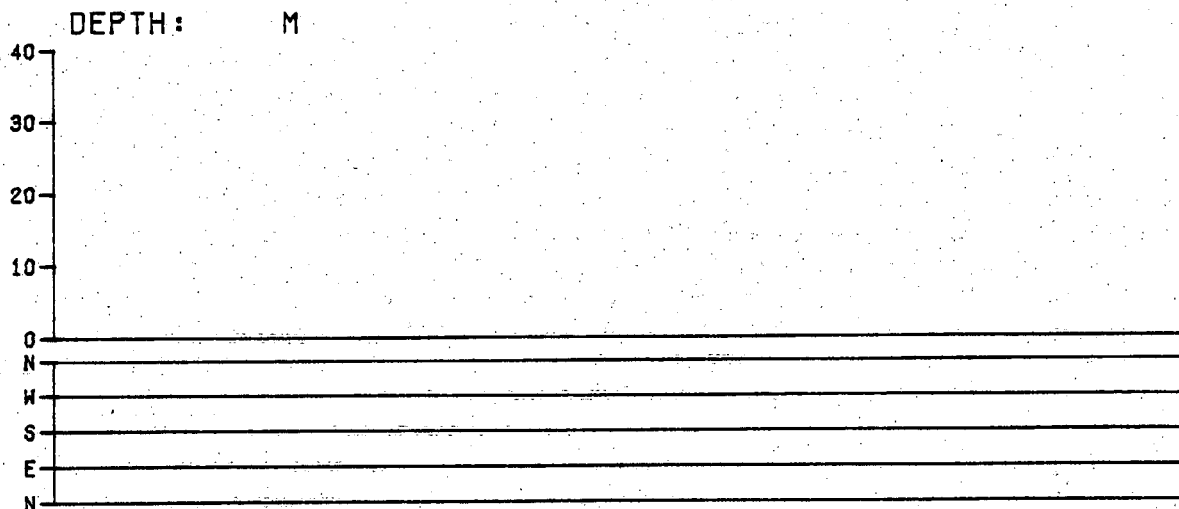
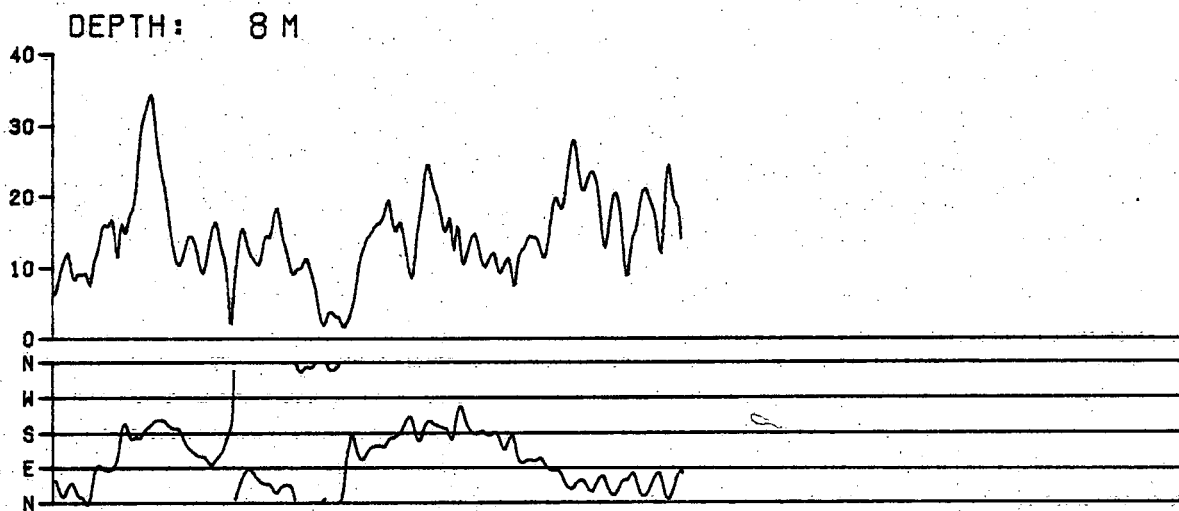

1 2 3 4 5 6 7 8 9 10 11 12 13 14 15 16 17 18 19 20 21 22 23 24 25 26 27 28 29 30 31

MOORING: 30

DATE: OCT 1973

TEMPERATURE °C

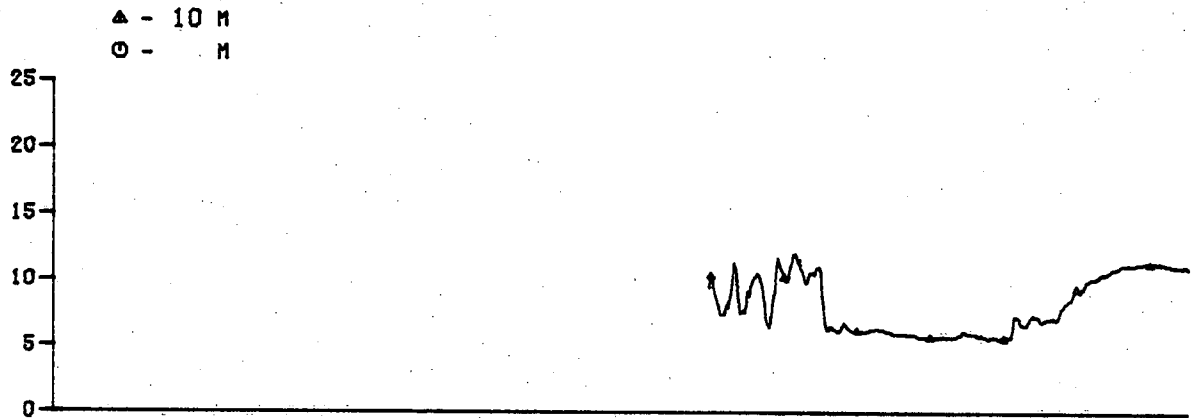

FILTERED CURRENT (0.0 TO 0.2 CPH) CM/SEC

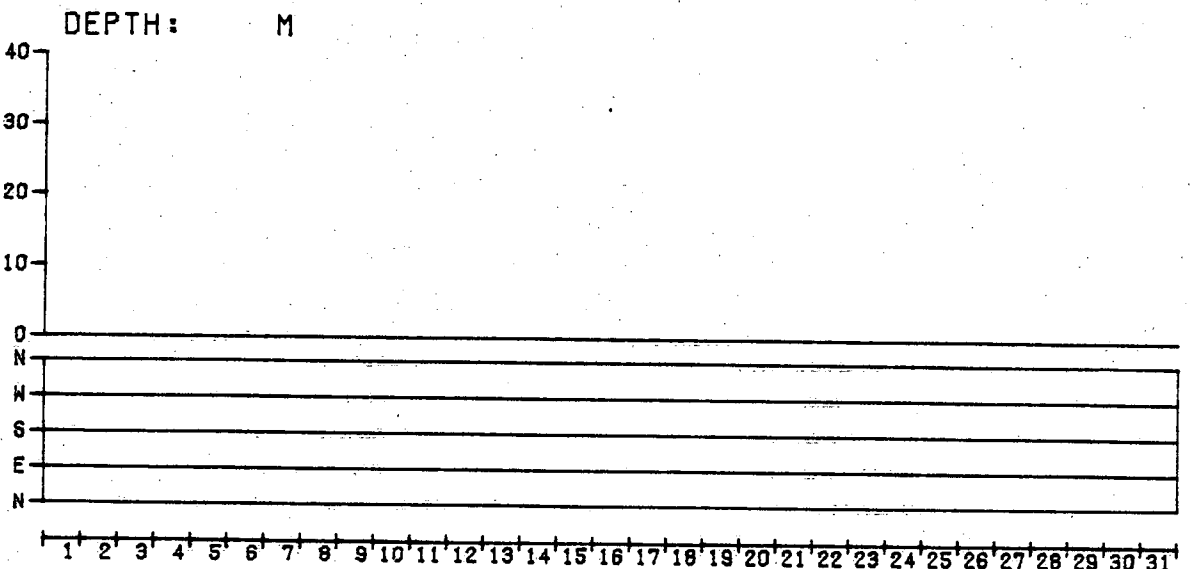
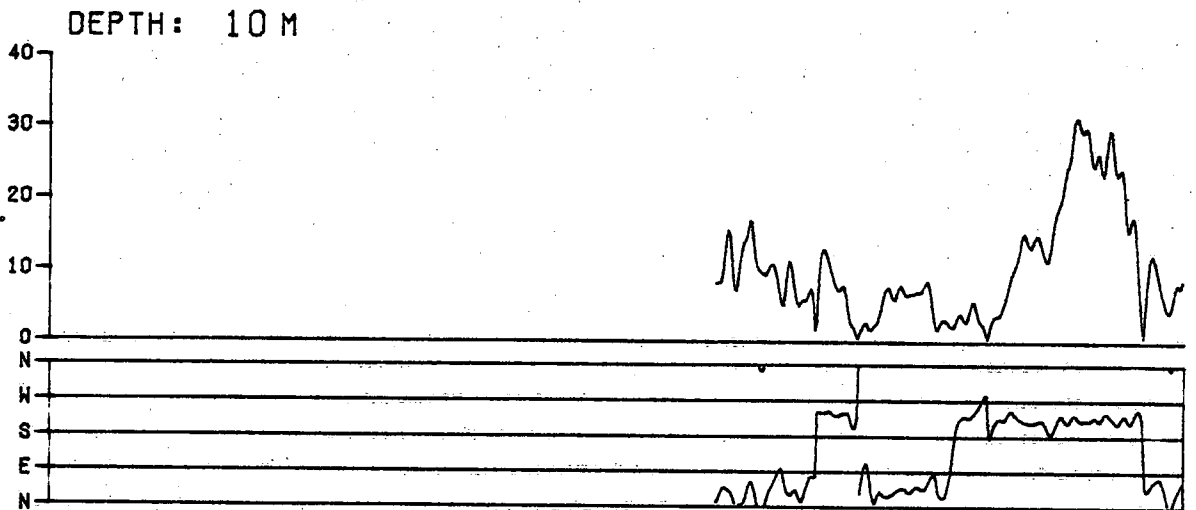

MOORING: 31

DATE: OCT 1973

TEMPERATURE °C

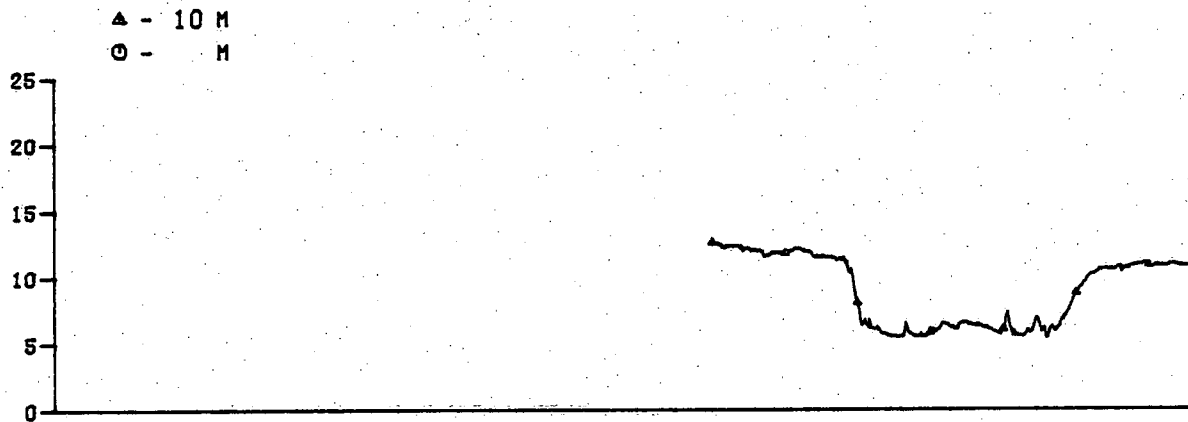

FILTERED CURRENT (0.0 TO 0.2 CPH) CM/SEC

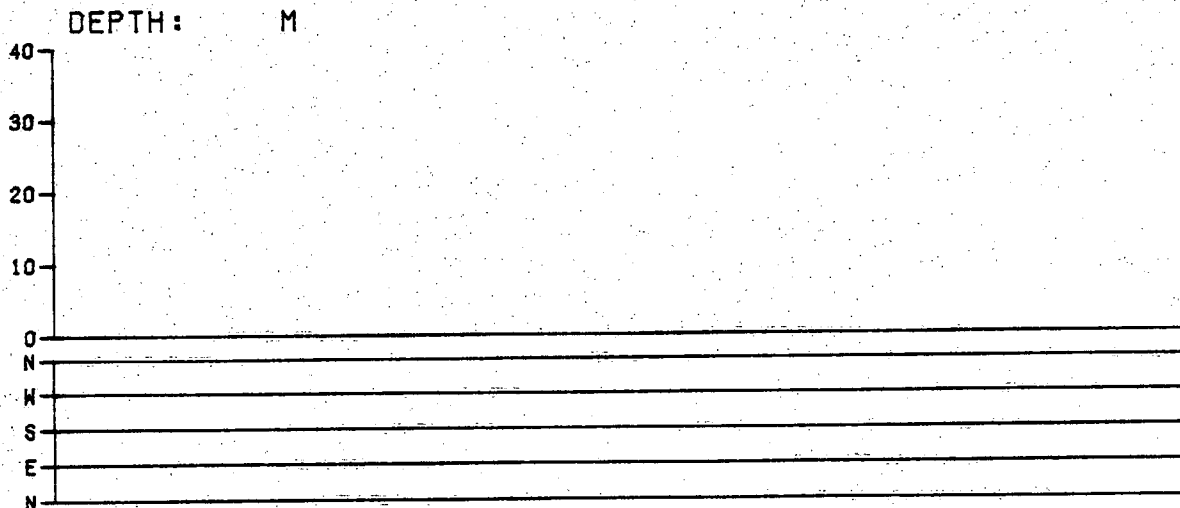
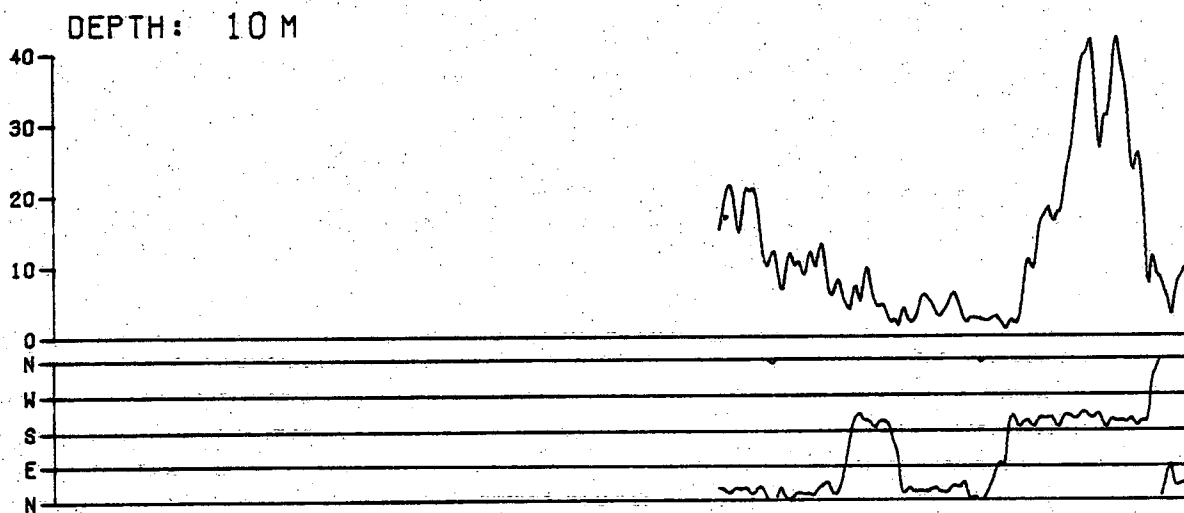

1' 2' 3' 4' 5' 6' 7' 8' 9' 10' 11' 12' 13' 14' 15' 16' 17' 18' 19' 20' 21' 22' 23' 24' 25' 26' 27' 28' 29' 30' 31'

MOORING : 32

DATE : OCT 1973

TEMPERATURE °C

▲ - 10 M  
○ - 51 M

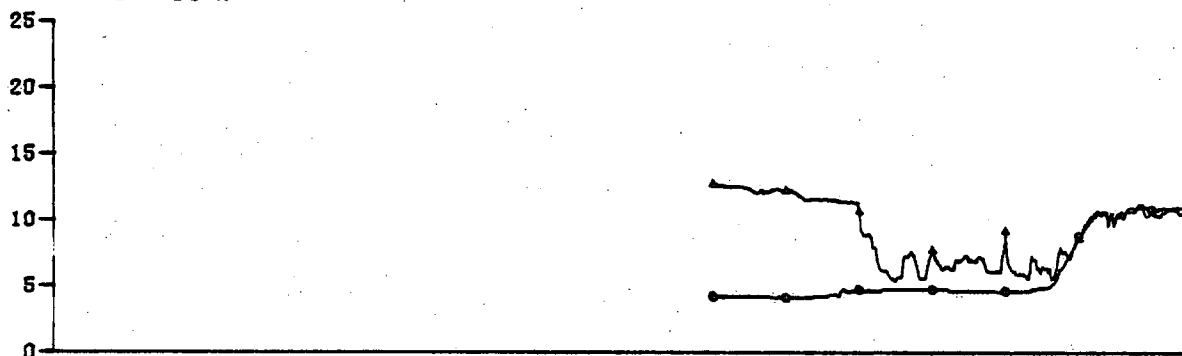

FILTERED CURRENT (0.0 TO 0.2 CPH) CM/SEC

DEPTH: 10 M

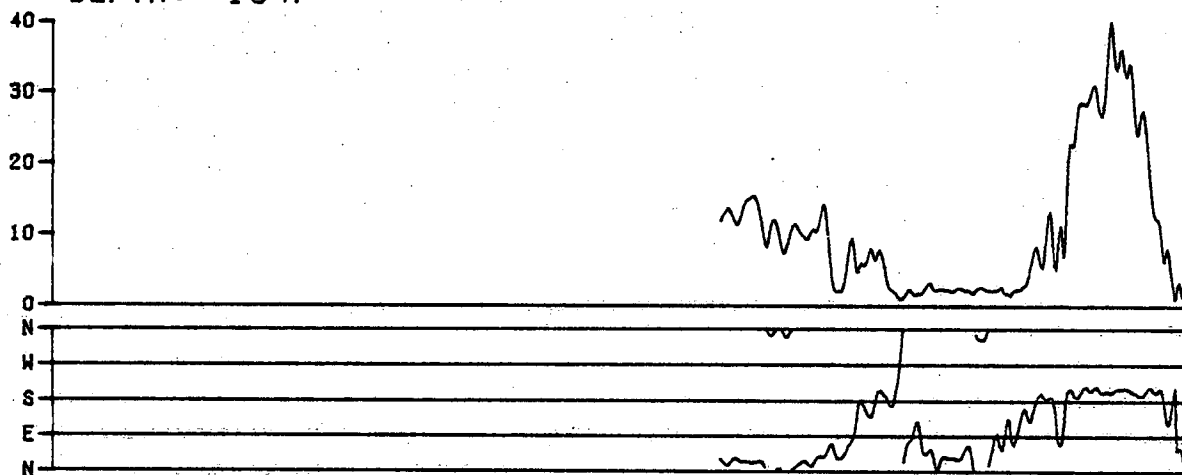

DEPTH: 51 M

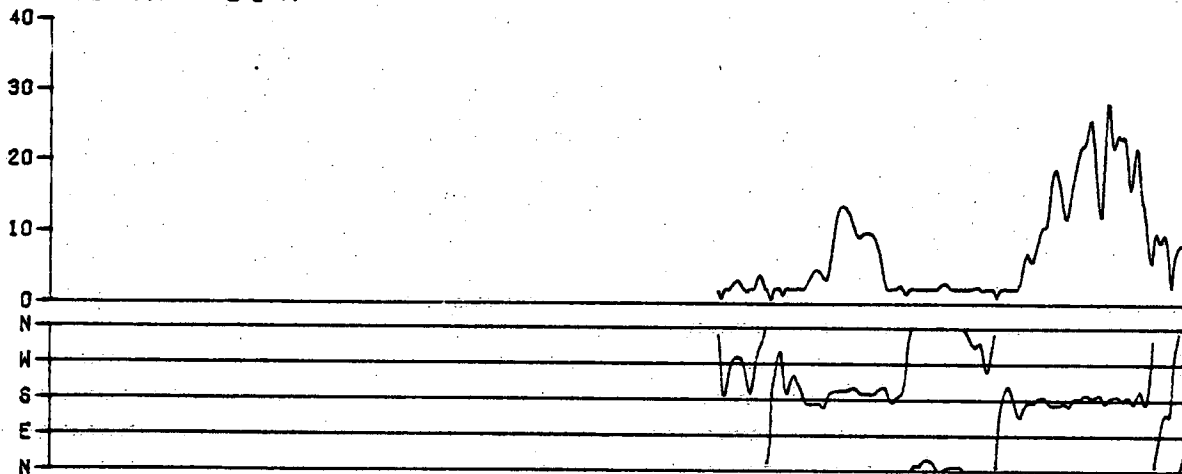

1' 2' 3' 4' 5' 6' 7' 8' 9' 10' 11' 12' 13' 14' 15' 16' 17' 18' 19' 20' 21' 22' 23' 24' 25' 26' 27' 28' 29' 30' 31'

MOORING: 33

DATE: OCT 1973

TEMPERATURE °C

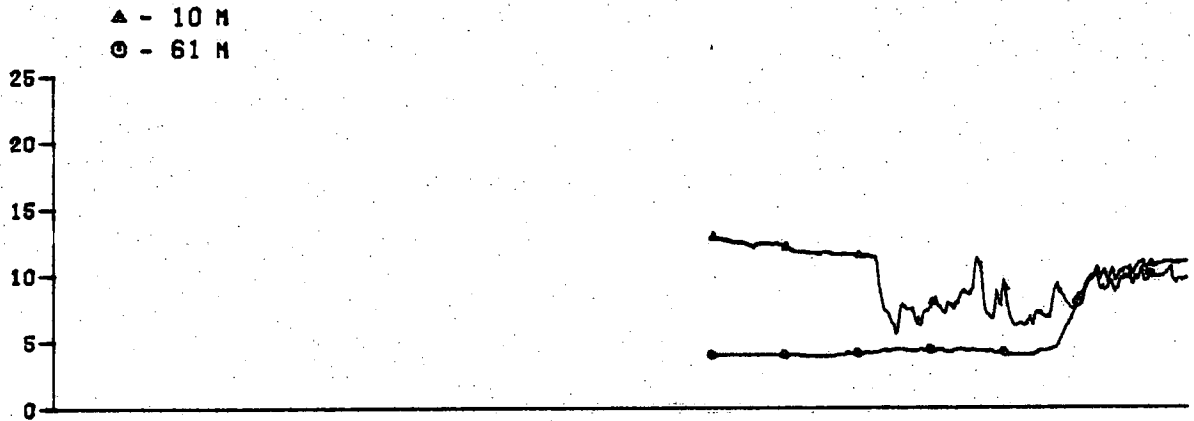

FILTERED CURRENT (0.0 TO 0.2 CPH) CM/SEC

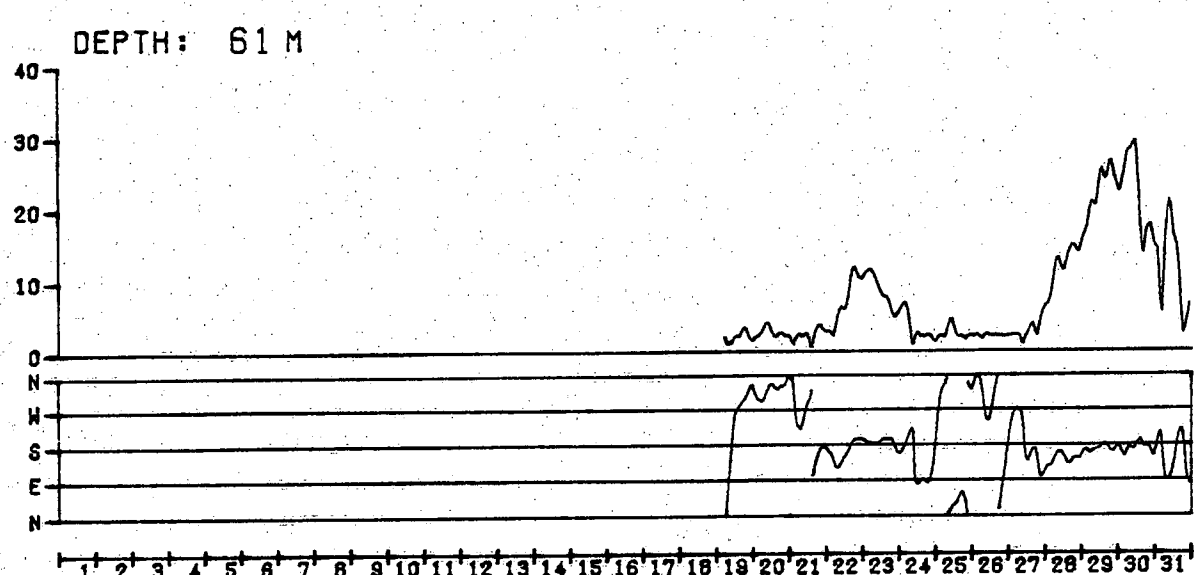
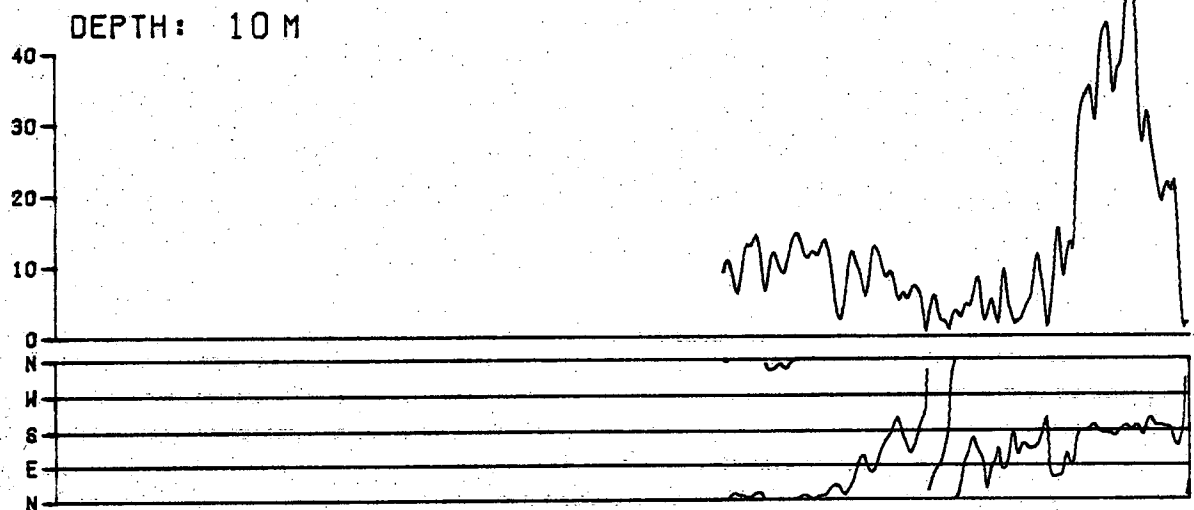

1' 2' 3' 4' 5' 6' 7' 8' 9' 10' 11' 12' 13' 14' 15' 16' 17' 18' 19' 20' 21' 22' 23' 24' 25' 26' 27' 28' 29' 30' 31'

MOORING: 34

DATE: OCT 1973

TEMPERATURE °C

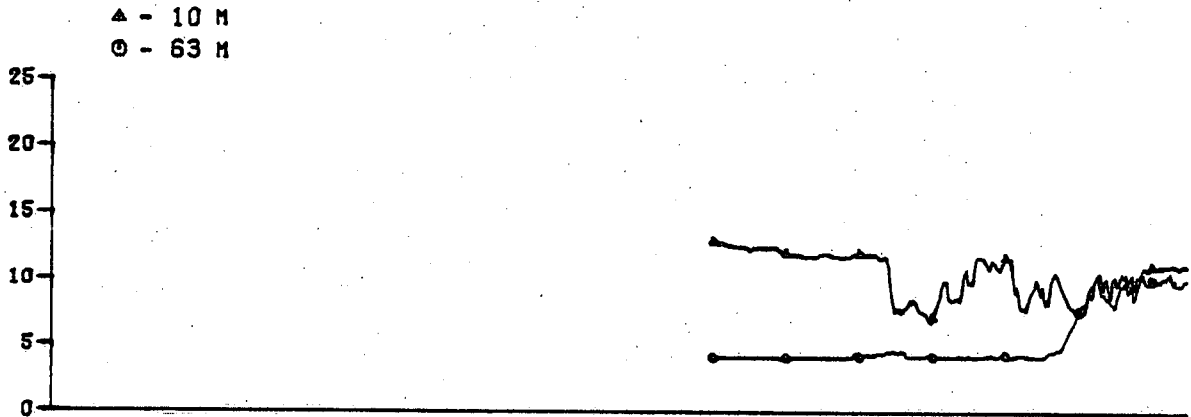

FILTERED CURRENT (0.0 TO 0.2 CPH) CM/SEC

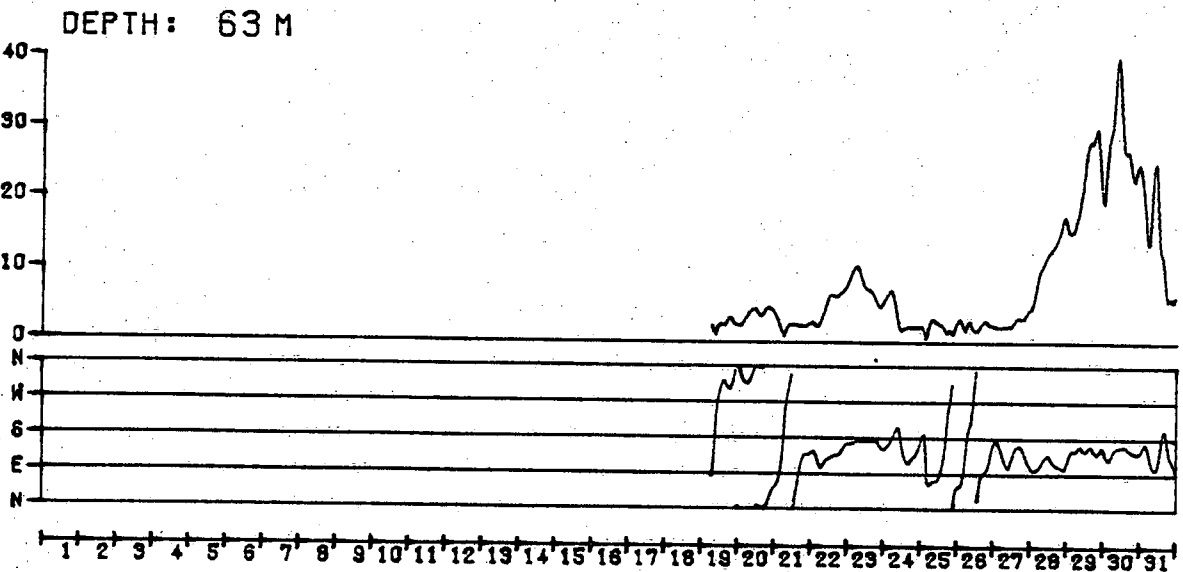
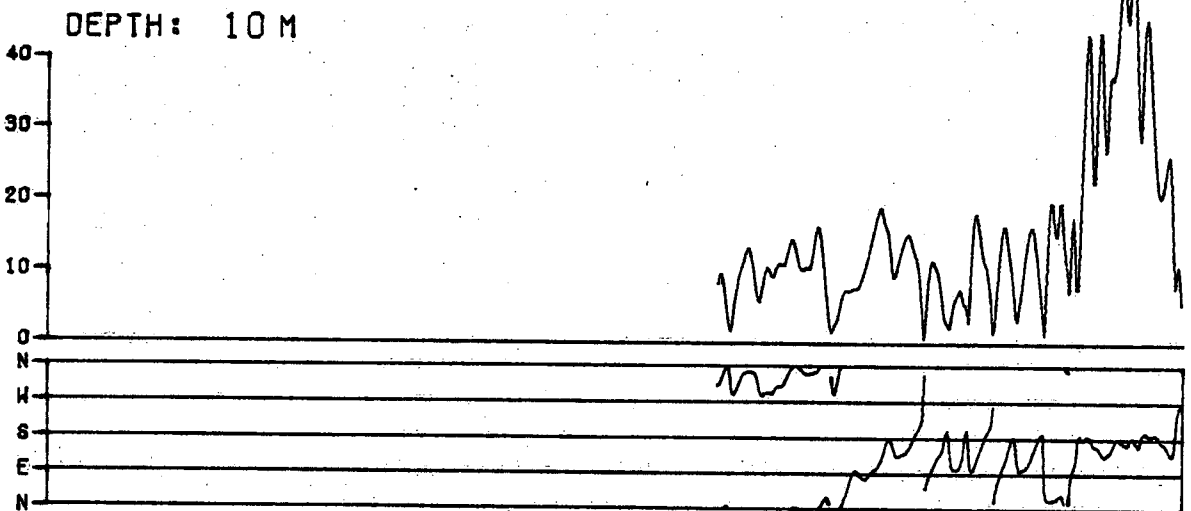

1' 2' 3' 4' 5' 6' 7' 8' 9' 10' 11' 12' 13' 14' 15' 16' 17' 18' 19' 20' 21' 22' 23' 24' 25' 26' 27' 28' 29' 30' 31'

MOORING: 35

DATE: OCT 1973

TEMPERATURE °C

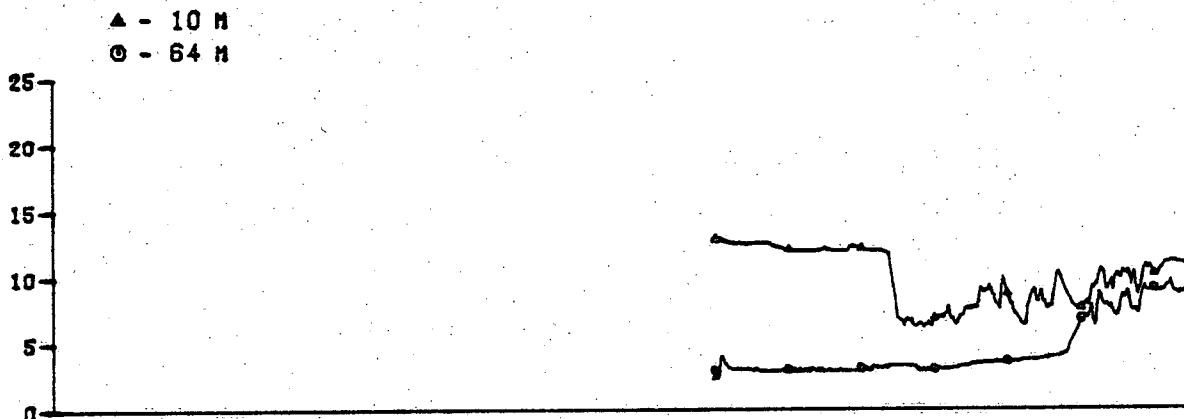

FILTERED CURRENT (0.0 TO 0.2 CPH) CM/SEC

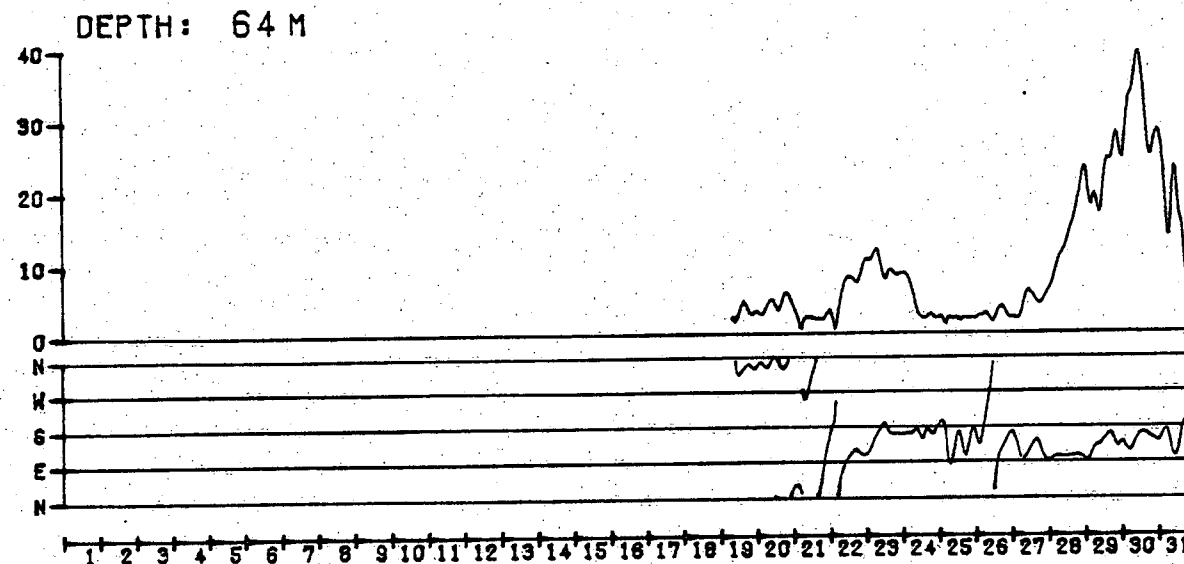
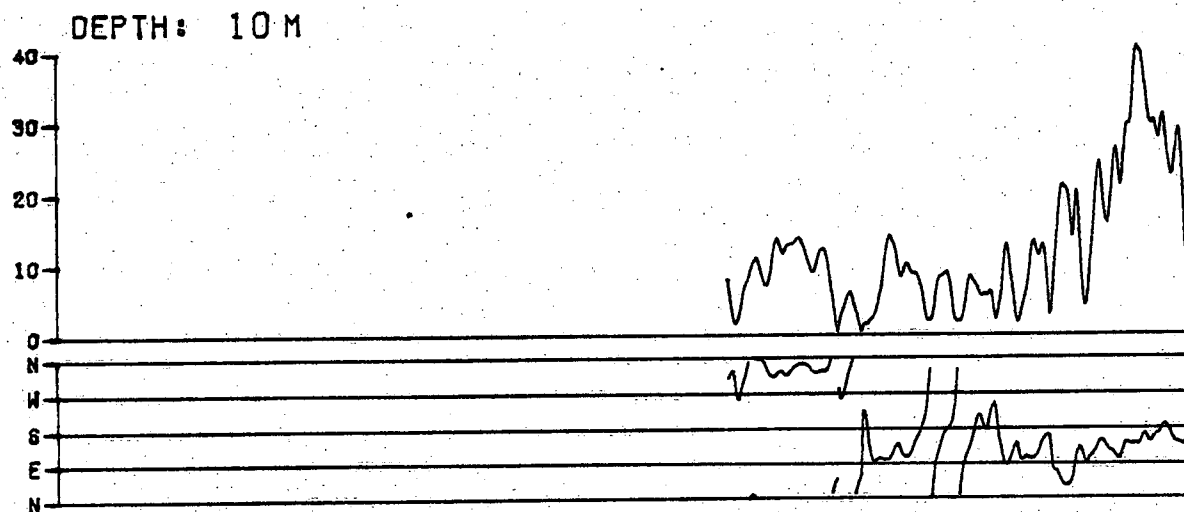

1' 2' 3' 4' 5' 6' 7' 8' 9' 10' 11' 12' 13' 14' 15' 16' 17' 18' 19' 20' 21' 22' 23' 24' 25' 26' 27' 28' 29' 30' 31'



MOORING : 30

DATE : NOV 1973

TEMPERATURE °C

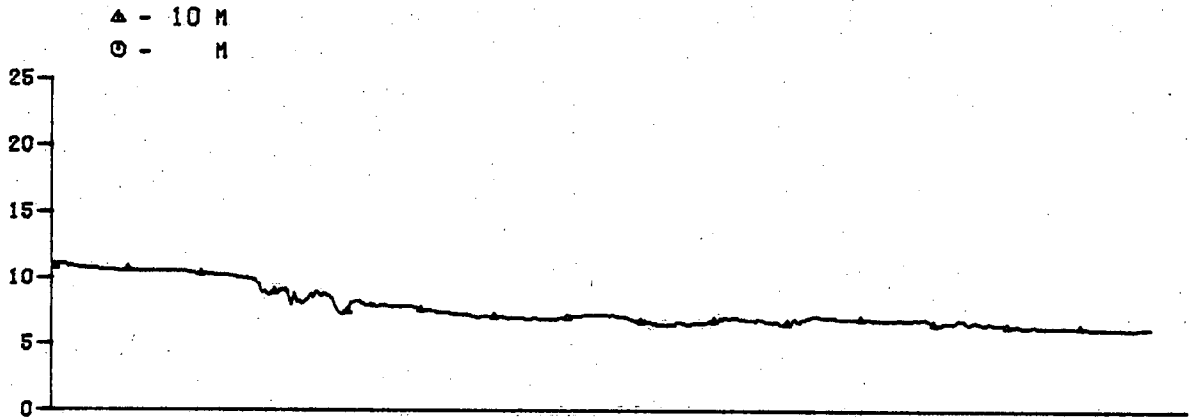

FILTERED CURRENT (0.0 TO 0.2 CPH) CM/SEC

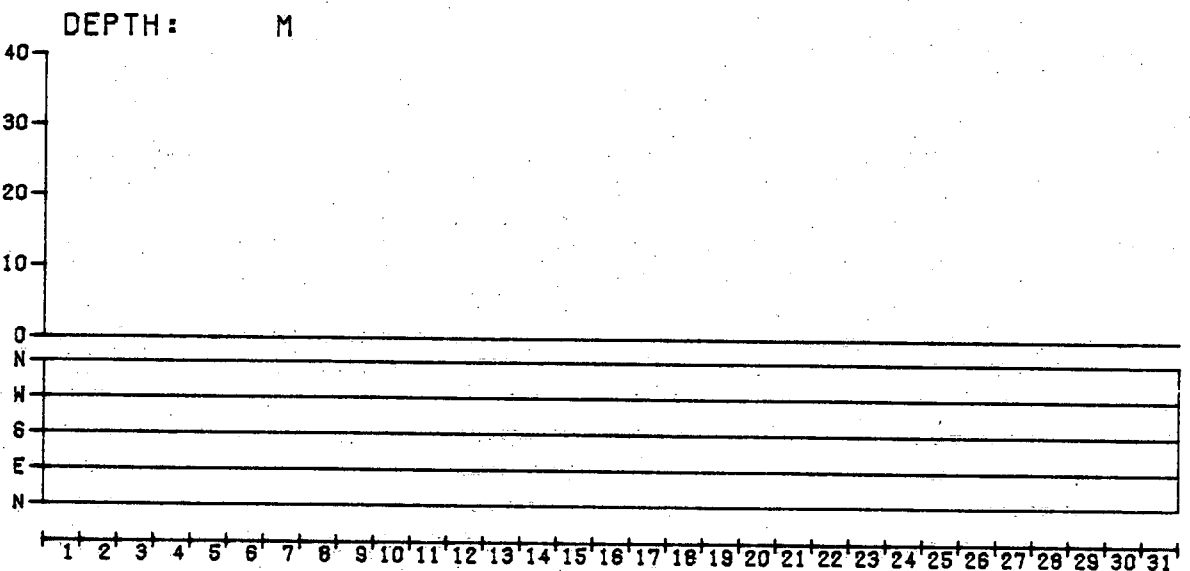
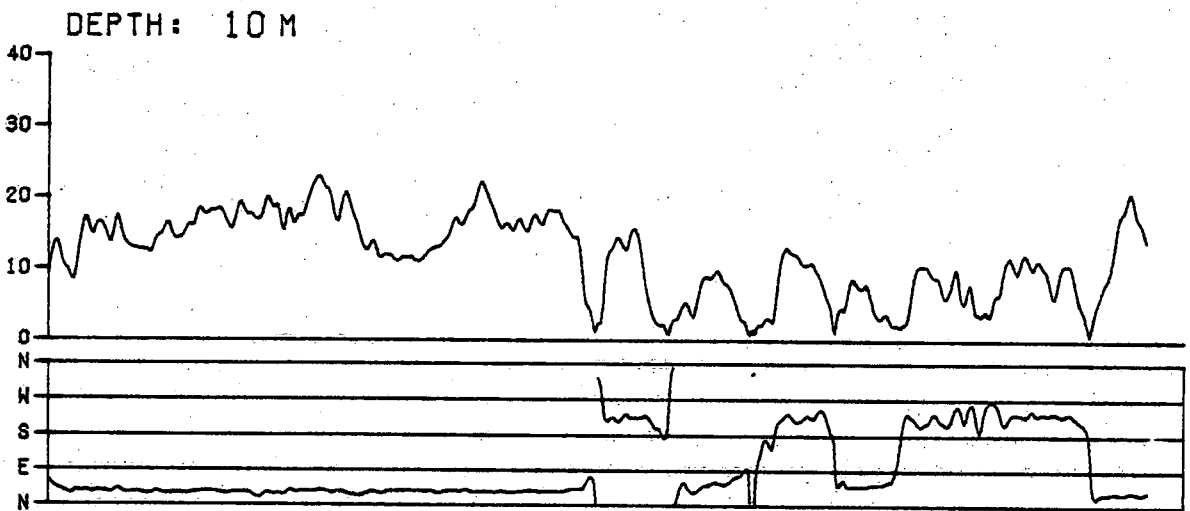

MOORING : 31

DATE : NOV 1973

TEMPERATURE °C

△ - 10 M  
○ - M

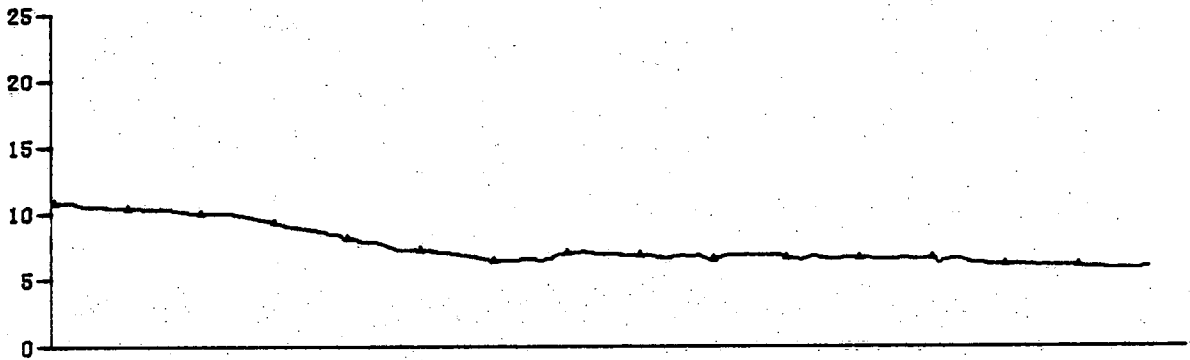

FILTERED CURRENT (0.0 TO 0.2 CPH) CM/SEC

DEPTH: 10 M

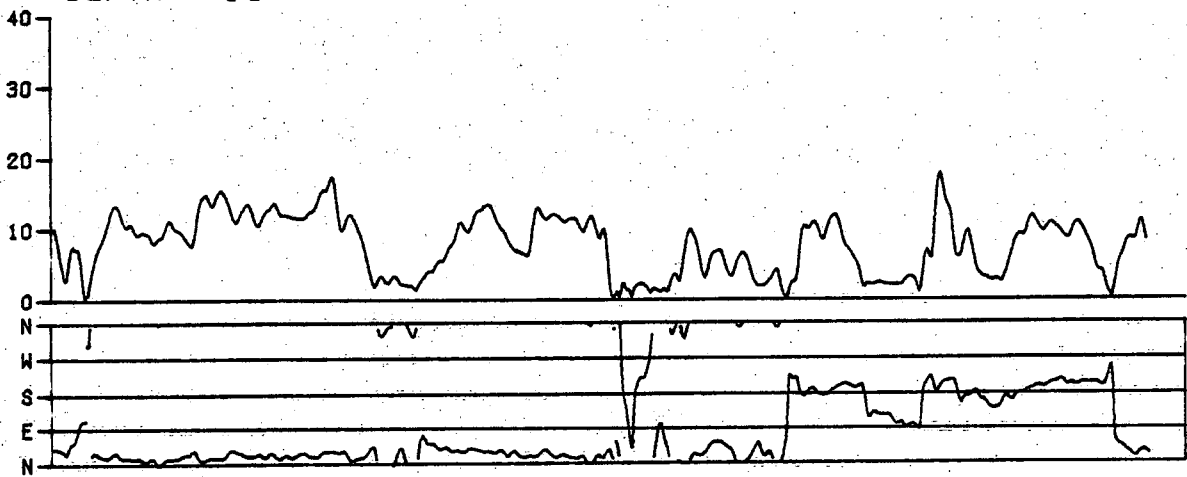

DEPTH: M

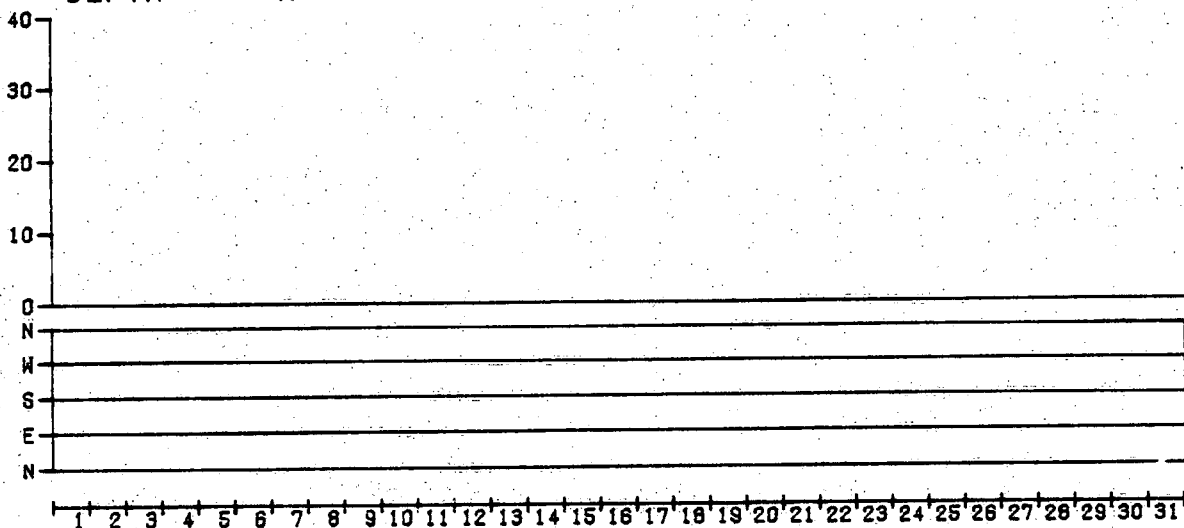

MOORING: 32

DATE: NOV 1973

TEMPERATURE °C

△ - 10 M  
○ - 51 M

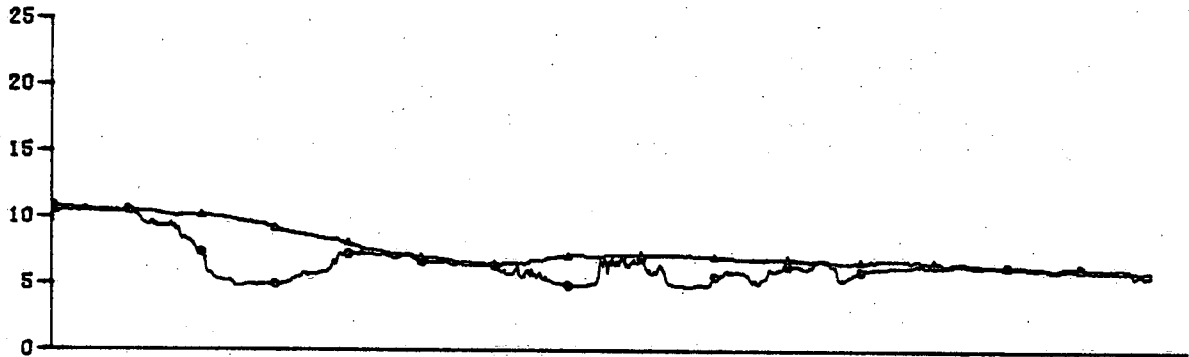

FILTERED CURRENT (0.0 TO 0.2 CPH) CM/SEC

DEPTH: 10 M

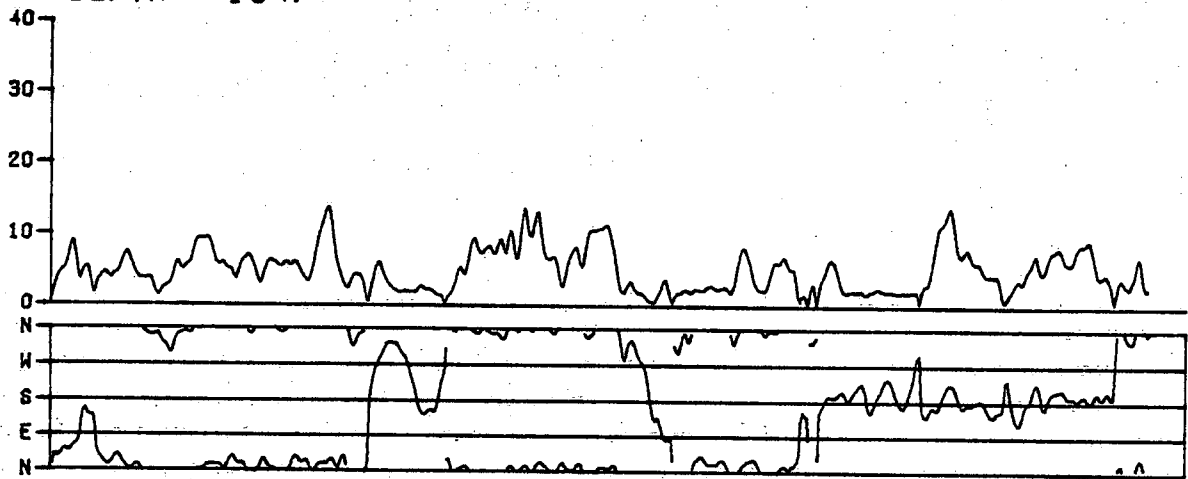

DEPTH: 51 M

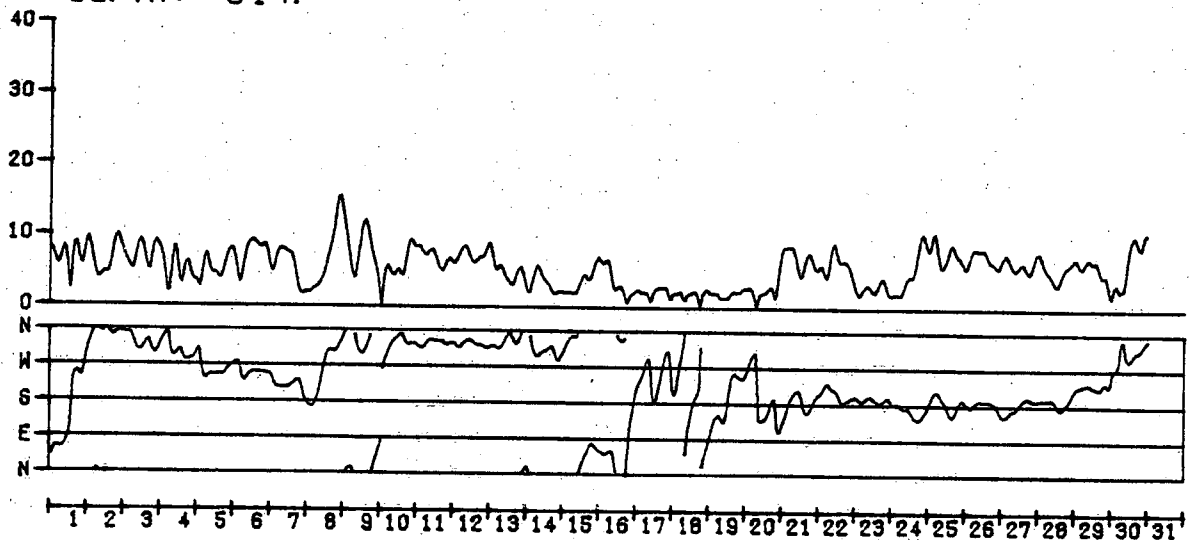

MOORING: 33

DATE: NOV 1973

TEMPERATURE °C

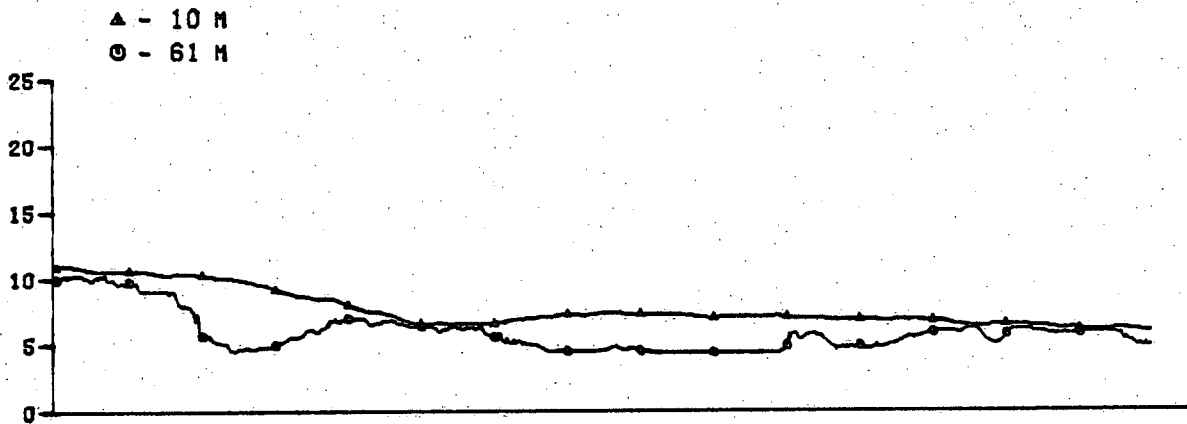

FILTERED CURRENT (0.0 TO 0.2 CPH) CM/SEC

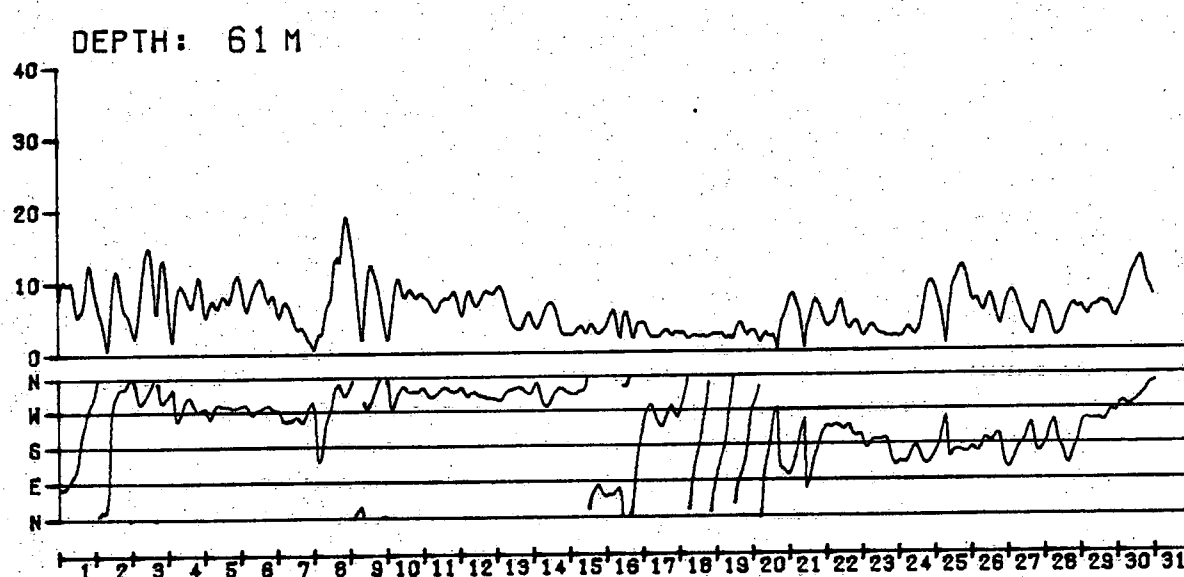
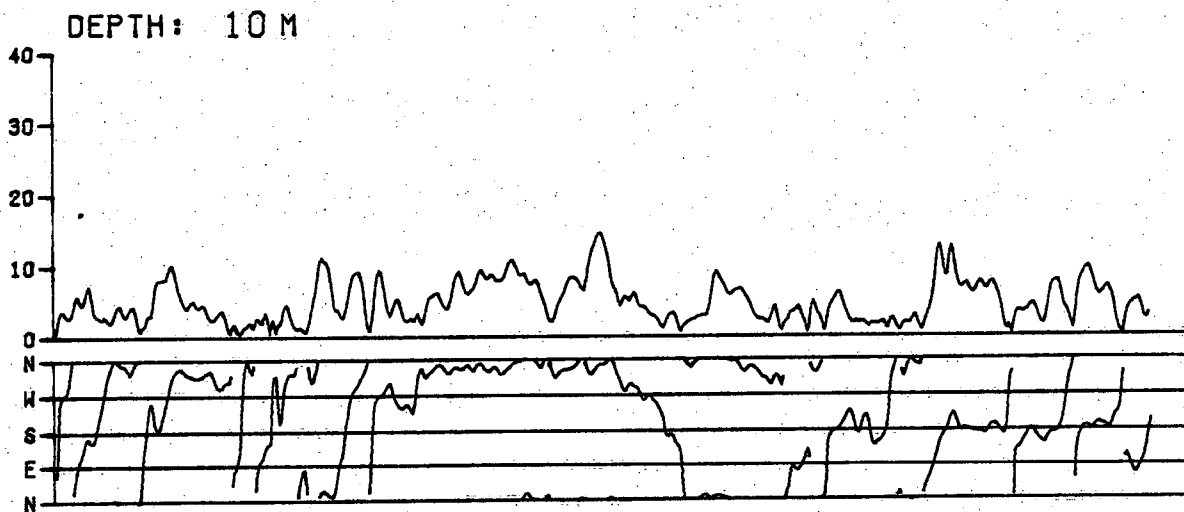

MOORING: 34

DATE: NOV 1973

TEMPERATURE °C

▲ - 10 M  
○ - 63 M

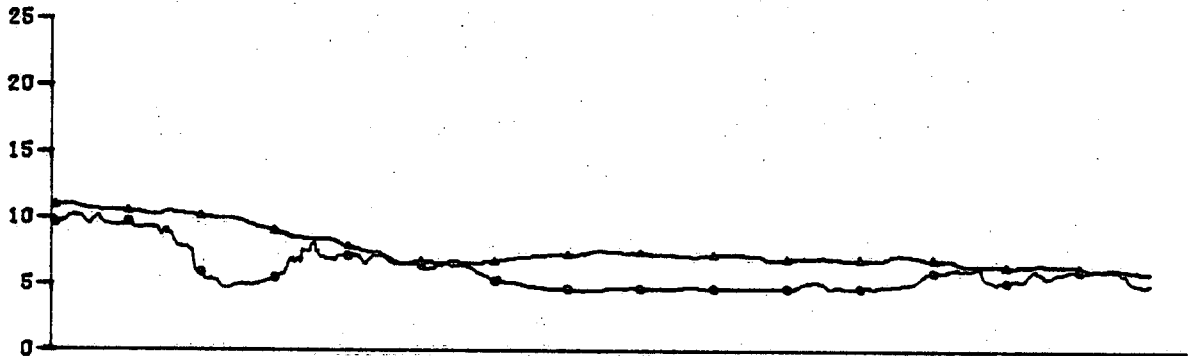

FILTERED CURRENT (0.0 TO 0.2 CPH) CM/SEC

DEPTH: 10 M

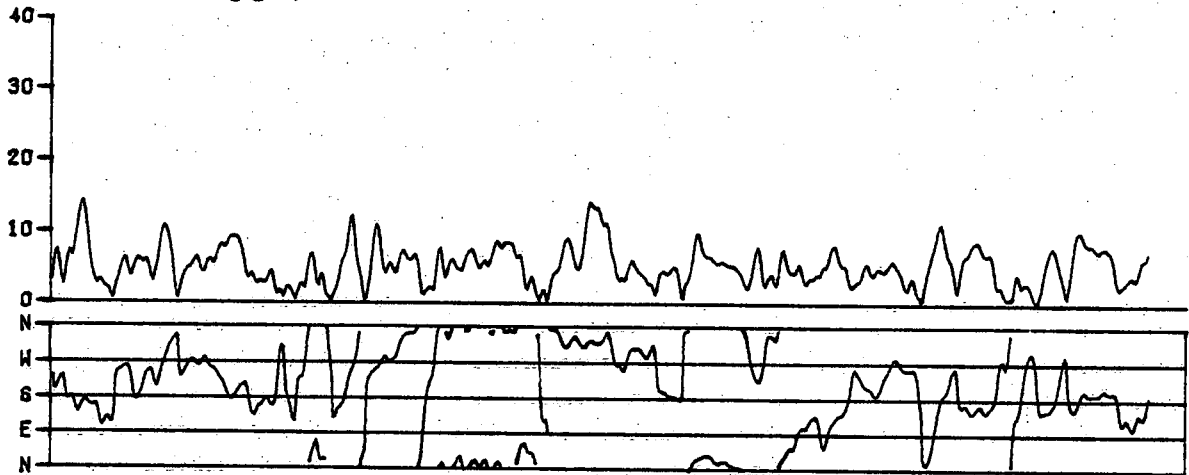

DEPTH: 63 M

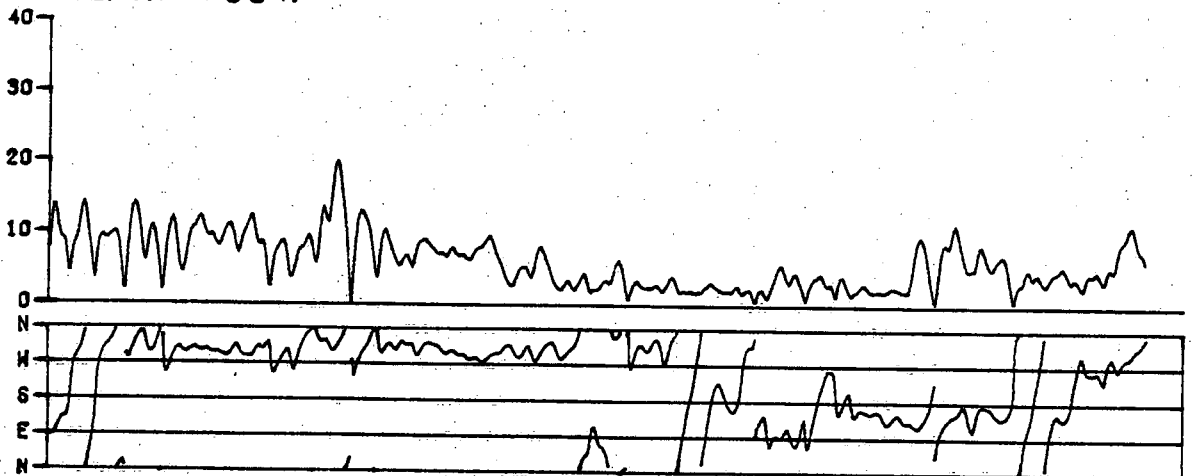

1' 2' 3' 4' 5' 6' 7' 8' 9' 10' 11' 12' 13' 14' 15' 16' 17' 18' 19' 20' 21' 22' 23' 24' 25' 26' 27' 28' 29' 30' 31'

MOORING: 35

DATE: NOV 1973

TEMPERATURE °C

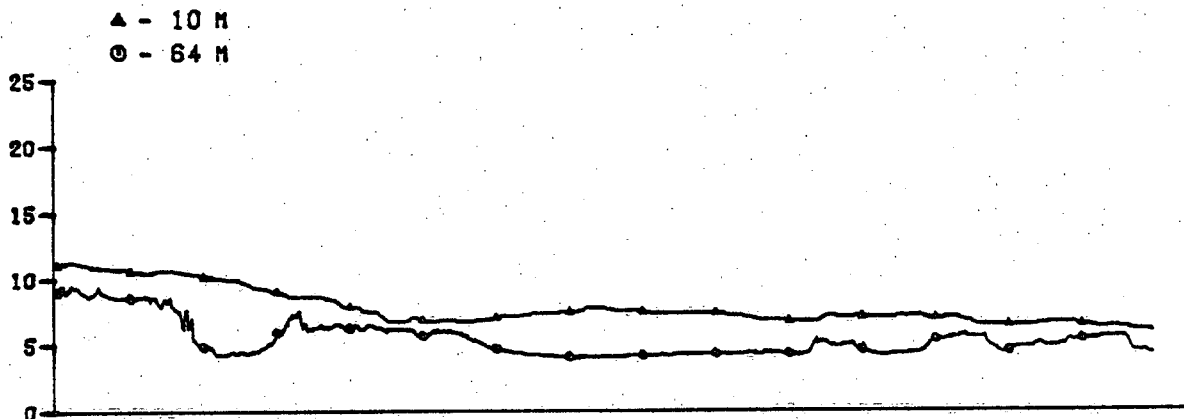

FILTERED CURRENT (0.0 TO 0.2 CPH) CM/SEC

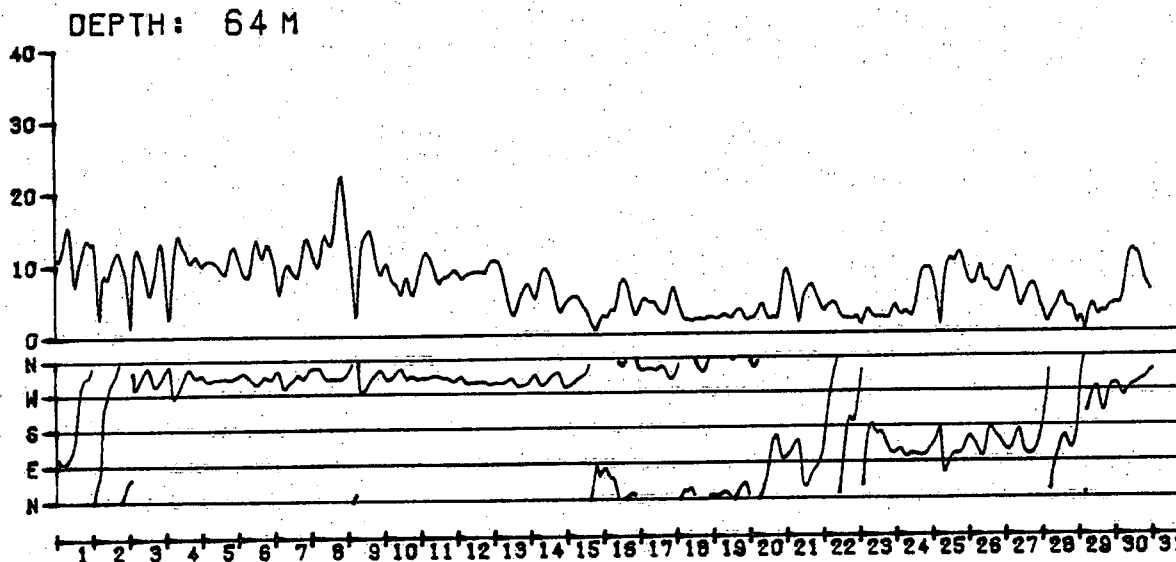
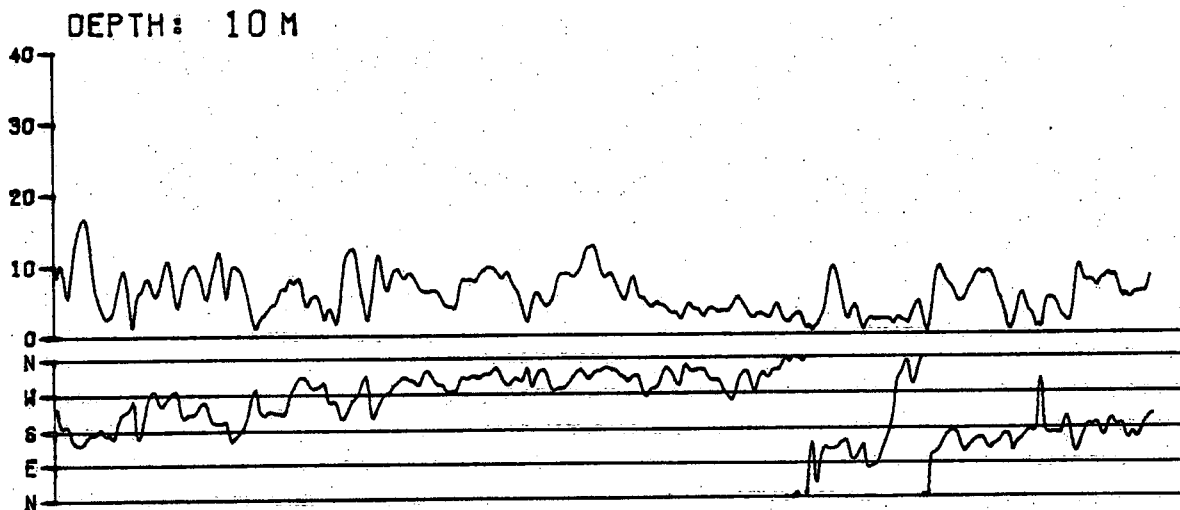

MOORING: 30

DATE: DEC 1973

TEMPERATURE °C

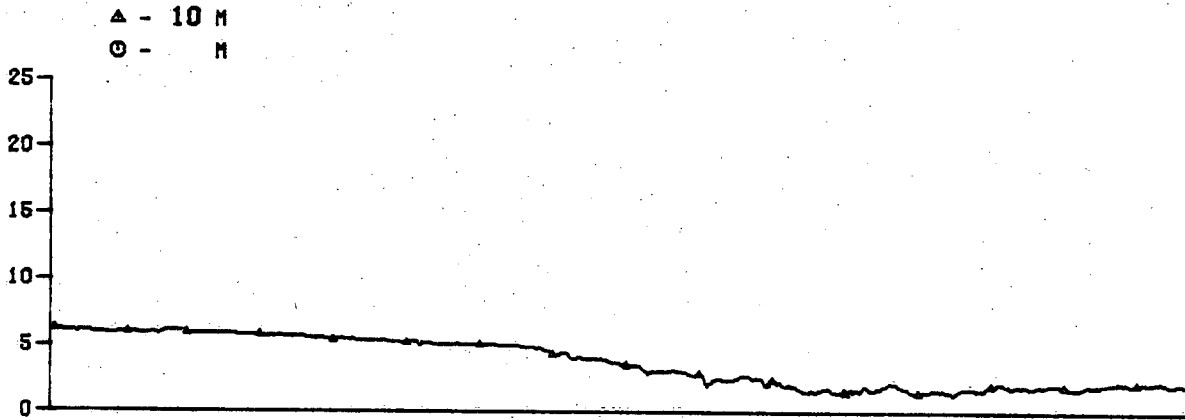

FILTERED CURRENT (0.0 TO 0.2 CPH) CM/SEC

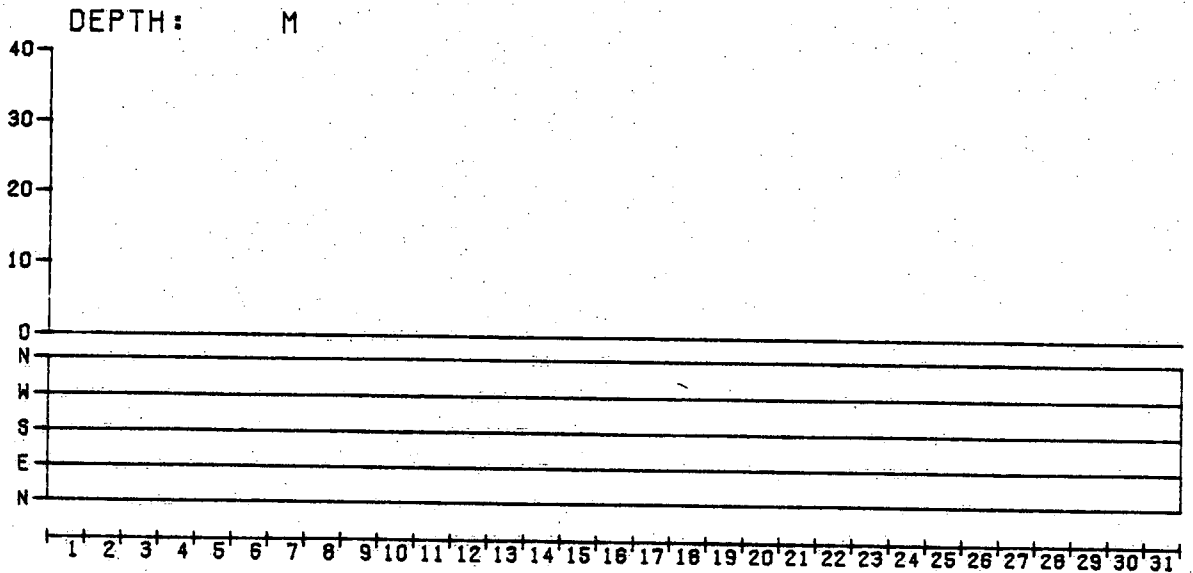
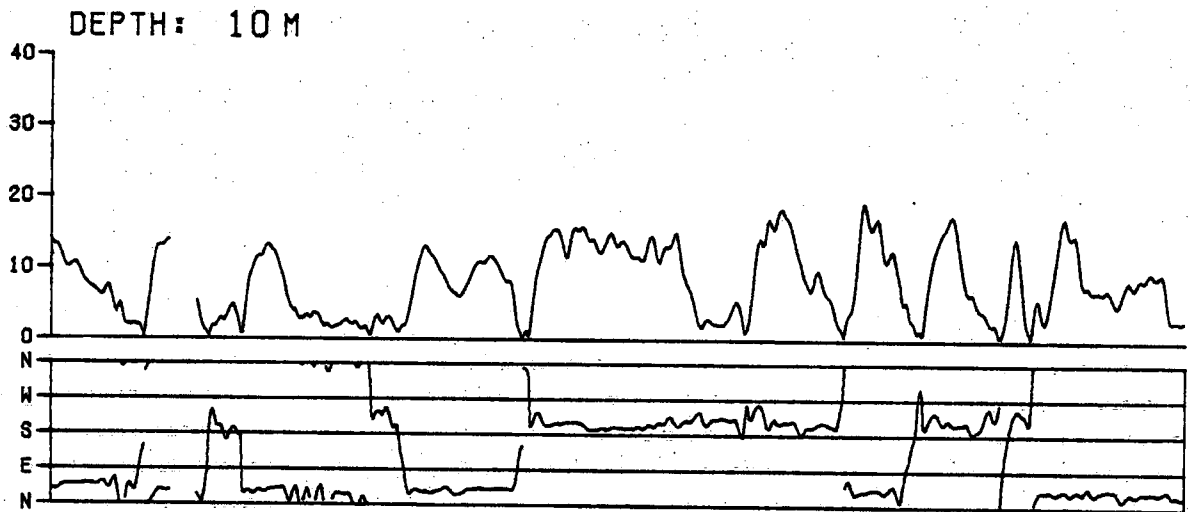

MOORING: 31

DATE: DEC 1973

TEMPERATURE °C

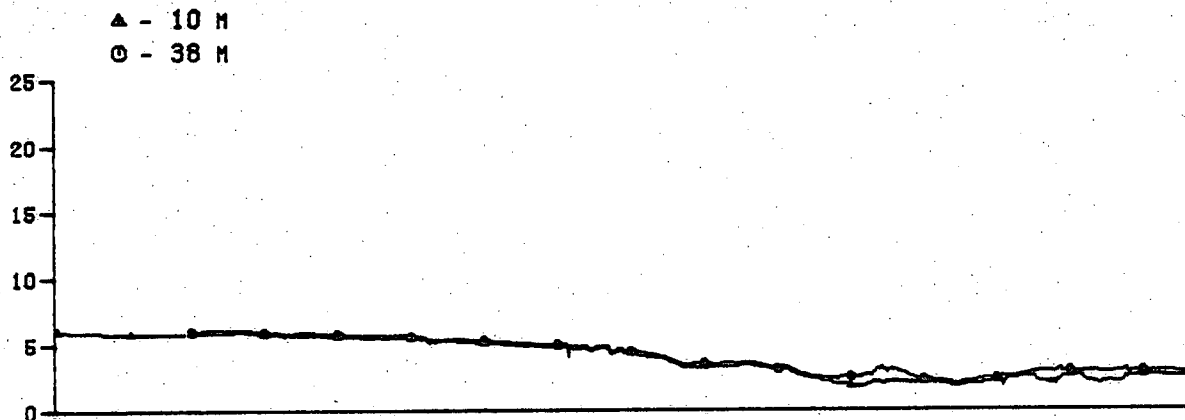

FILTERED CURRENT (0.0 TO 0.2 CPH) CM/SEC

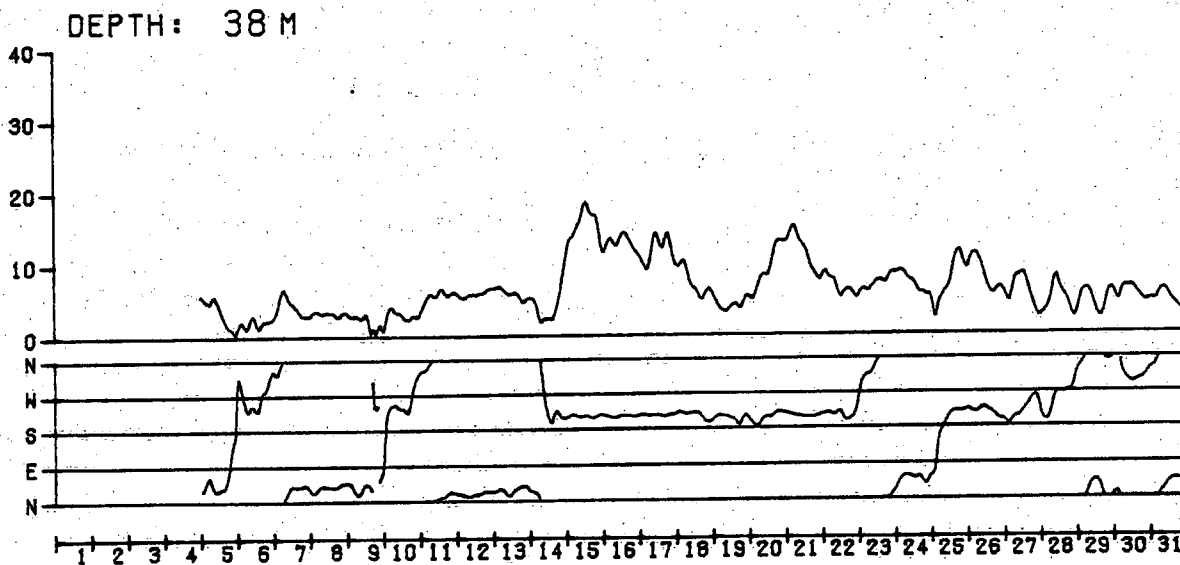
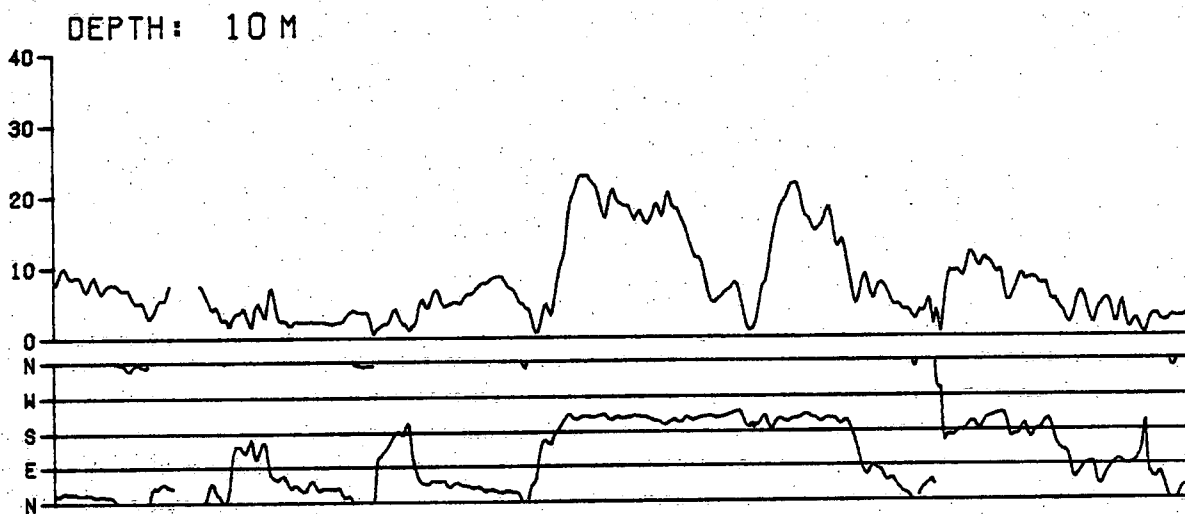



MOORING: 32

DATE: DEC 1973

TEMPERATURE °C

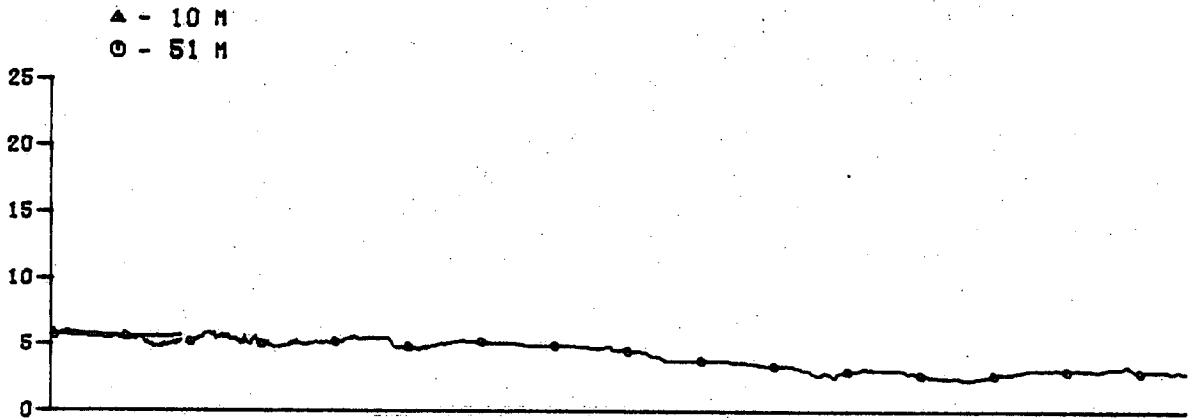

FILTERED CURRENT (0.0 TO 0.2 CPH) CM/SEC

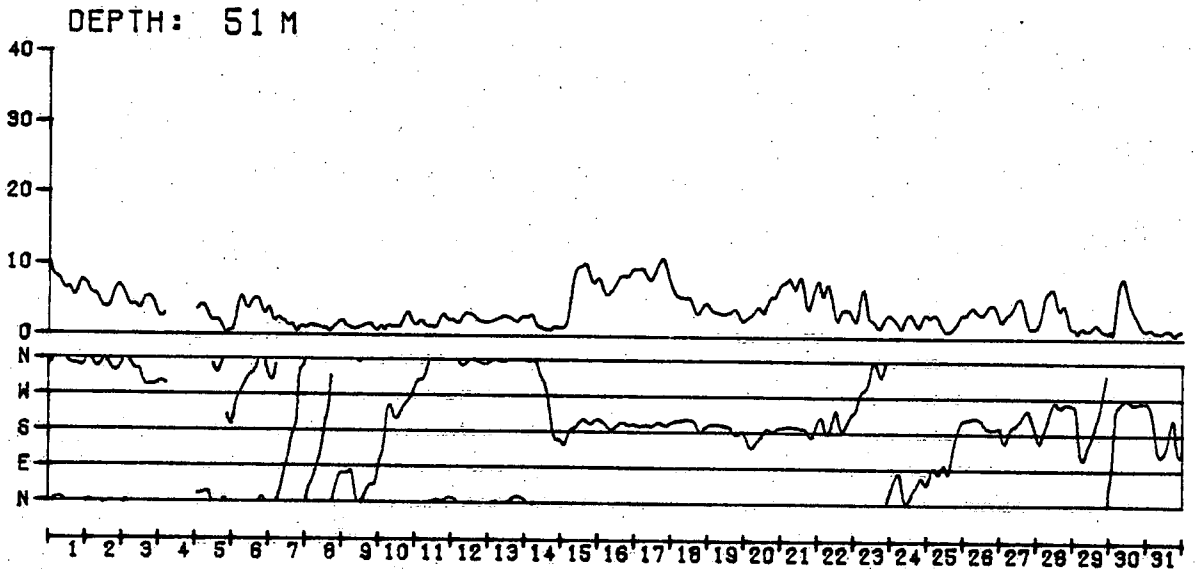
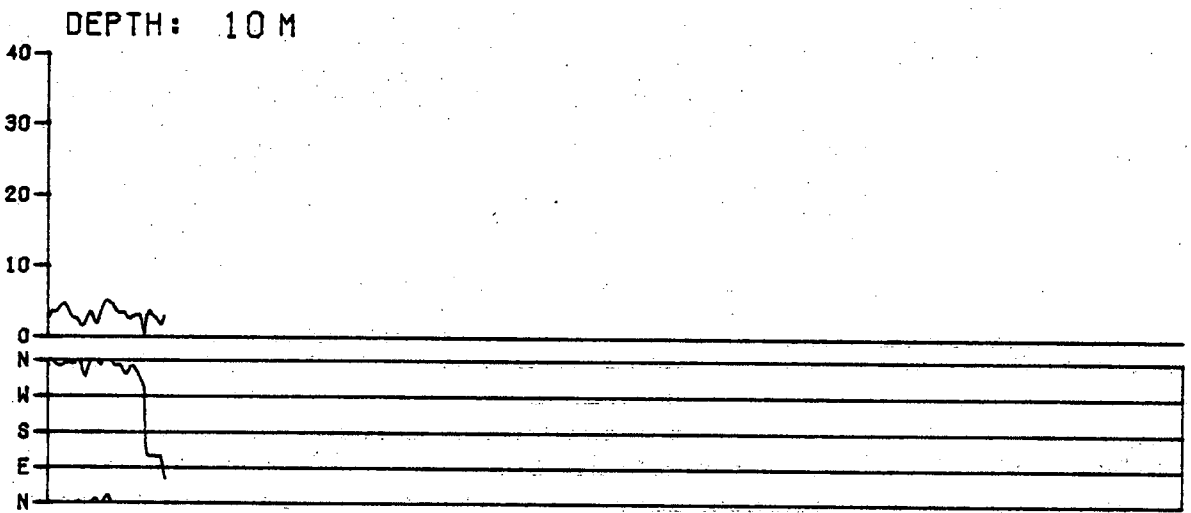

MOORING: 33

DATE: DEC 1973

TEMPERATURE °C

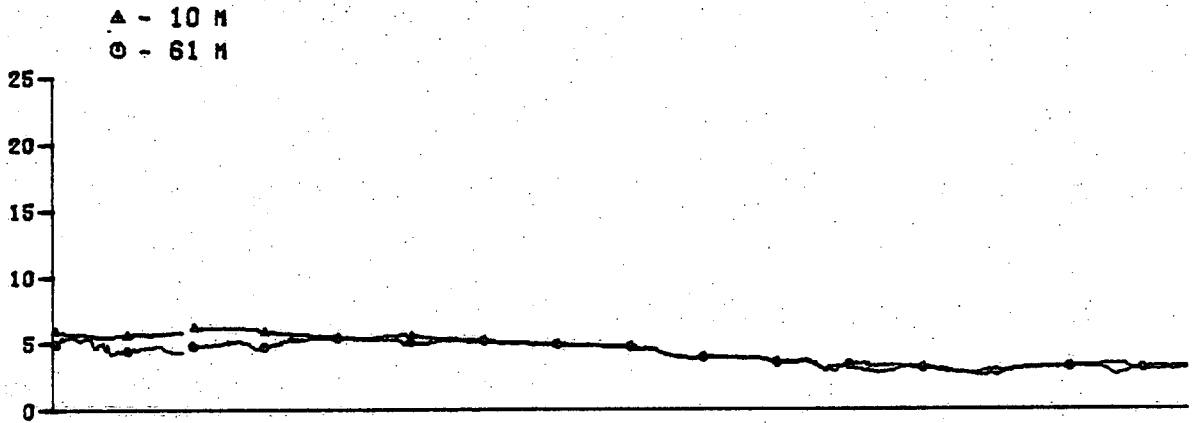

FILTERED CURRENT (0.0 TO 0.2 CPH) CM/SEC

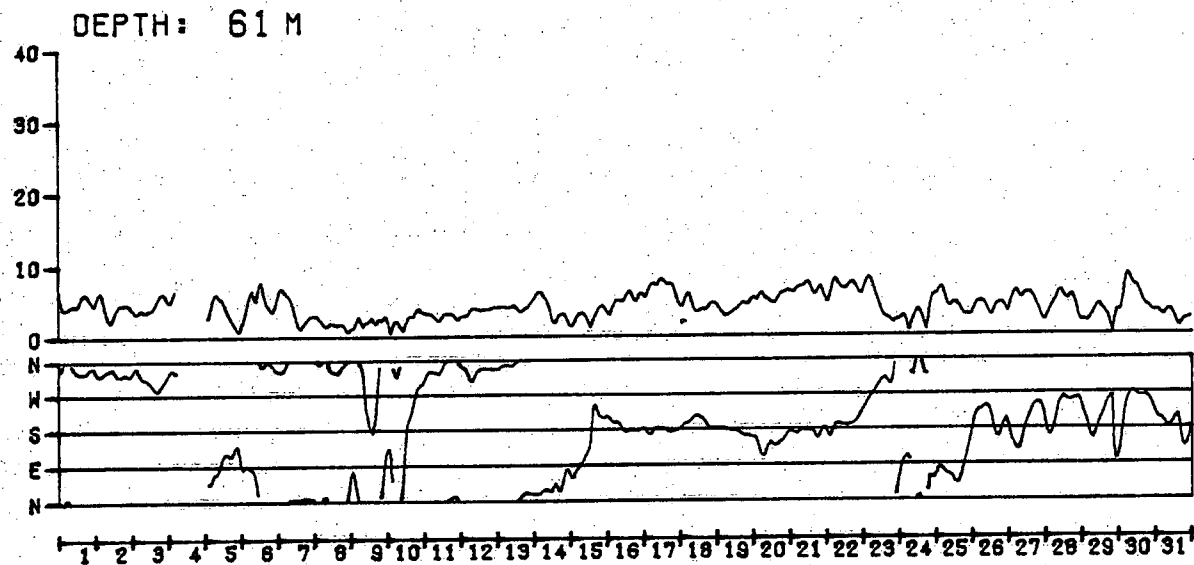
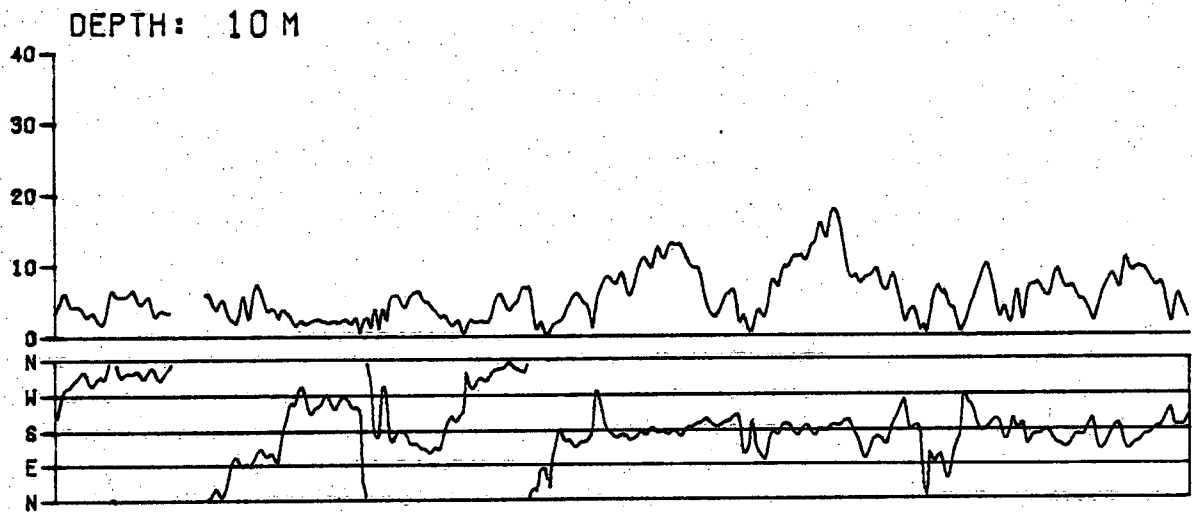

MOORING: 34

DATE: DEC 1973

TEMPERATURE °C

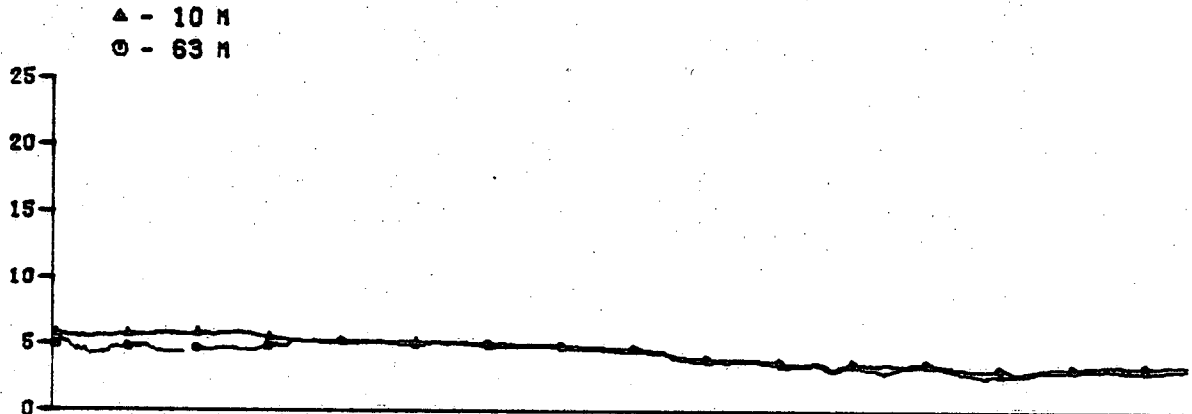

FILTERED CURRENT (0.0 TO 0.2 CPH) CM/SEC

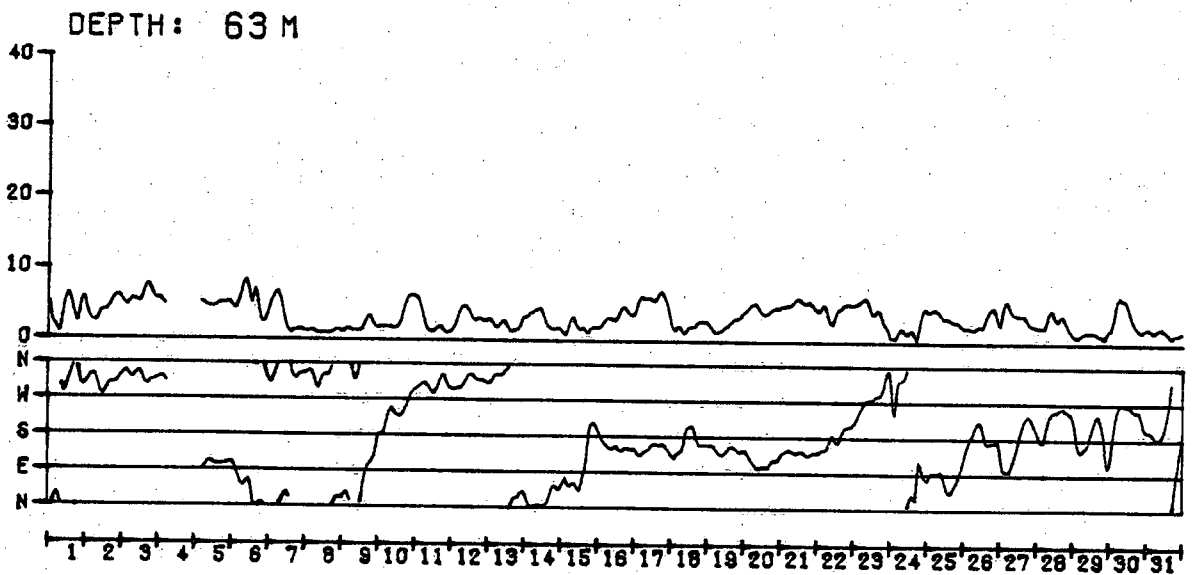
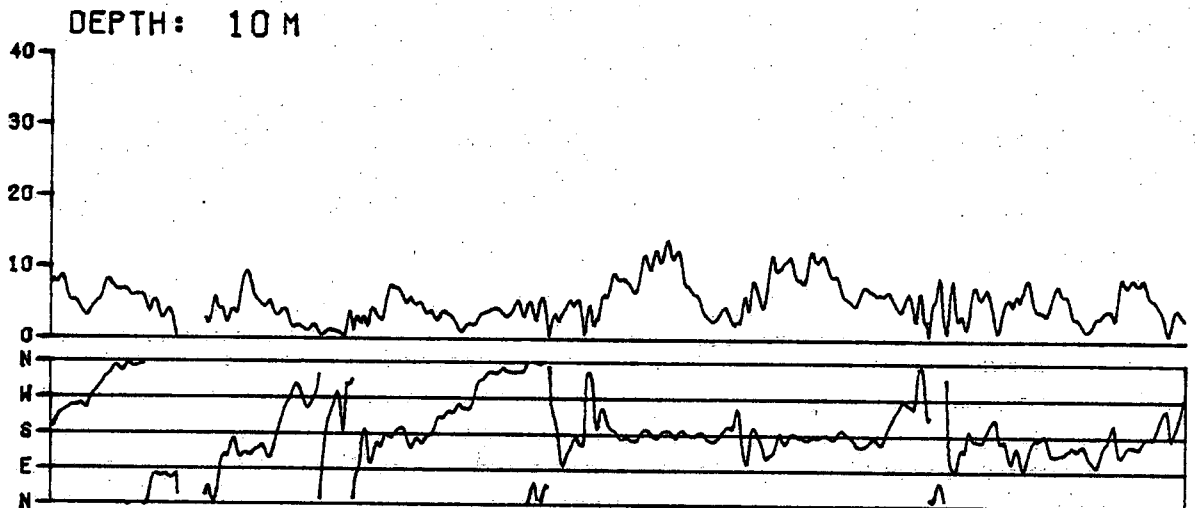

MOORING: 35

DATE: DEC 1973

TEMPERATURE °C

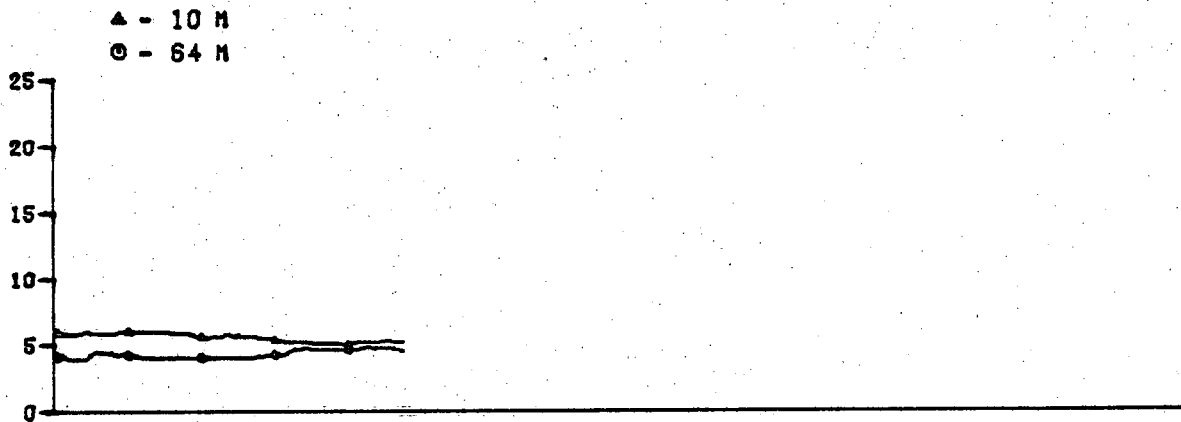

FILTERED CURRENT (0.0 TO 0.2 CPH) CM/SEC

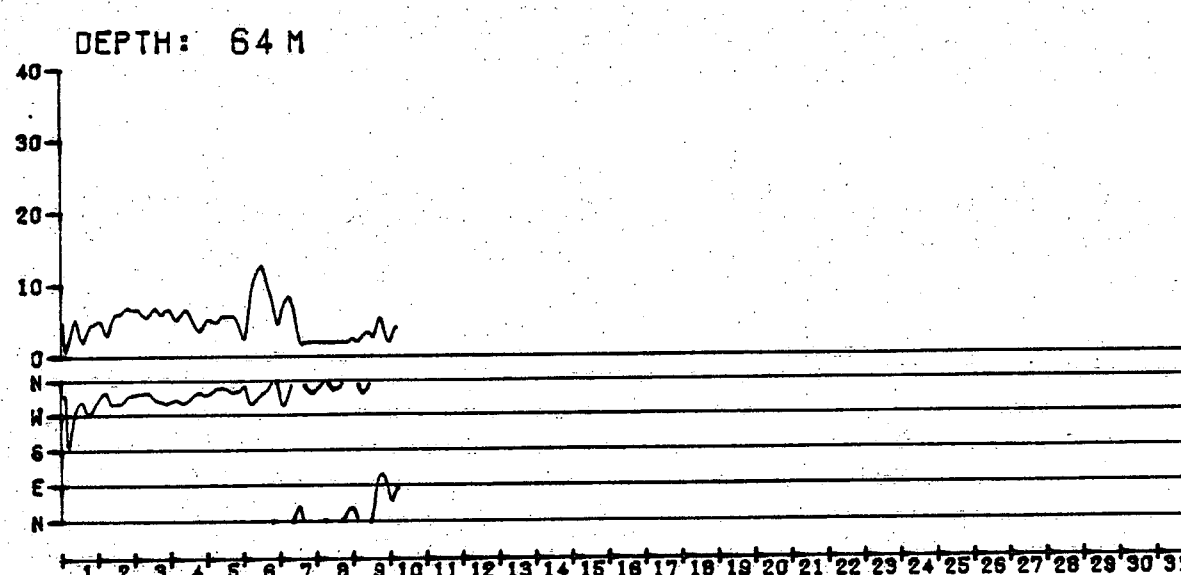
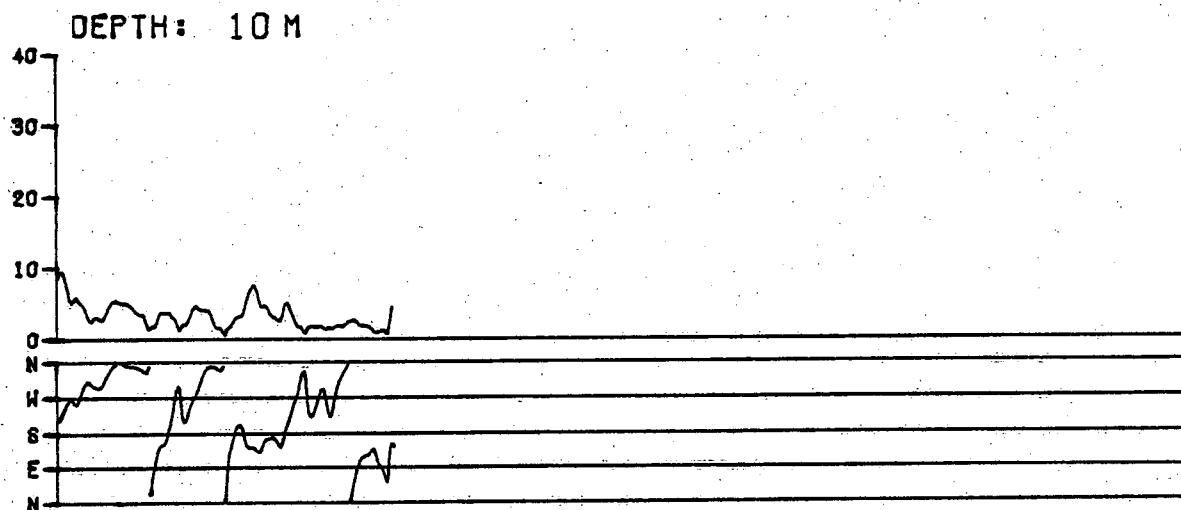

MOORING : 30

DATE : JAN 1974

TEMPERATURE °C

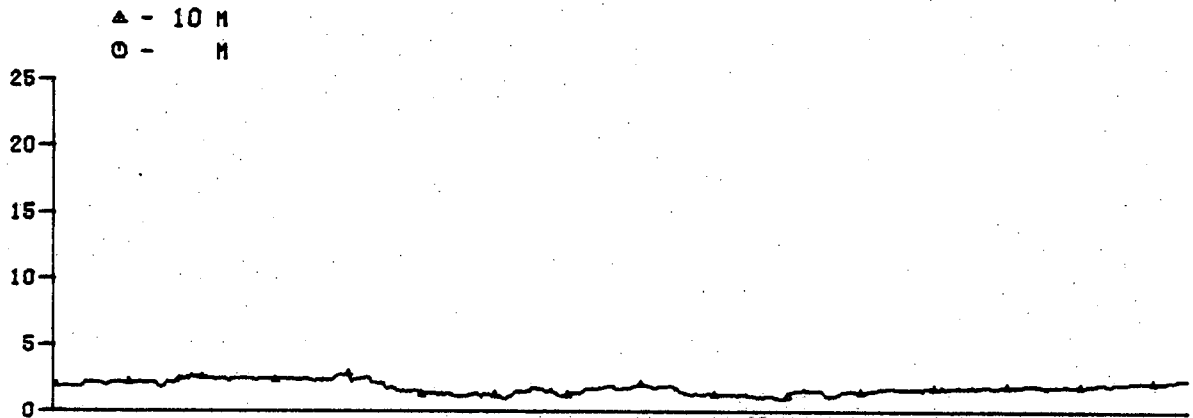

FILTERED CURRENT (0.0 TO 0.2 CPH) CM/SEC

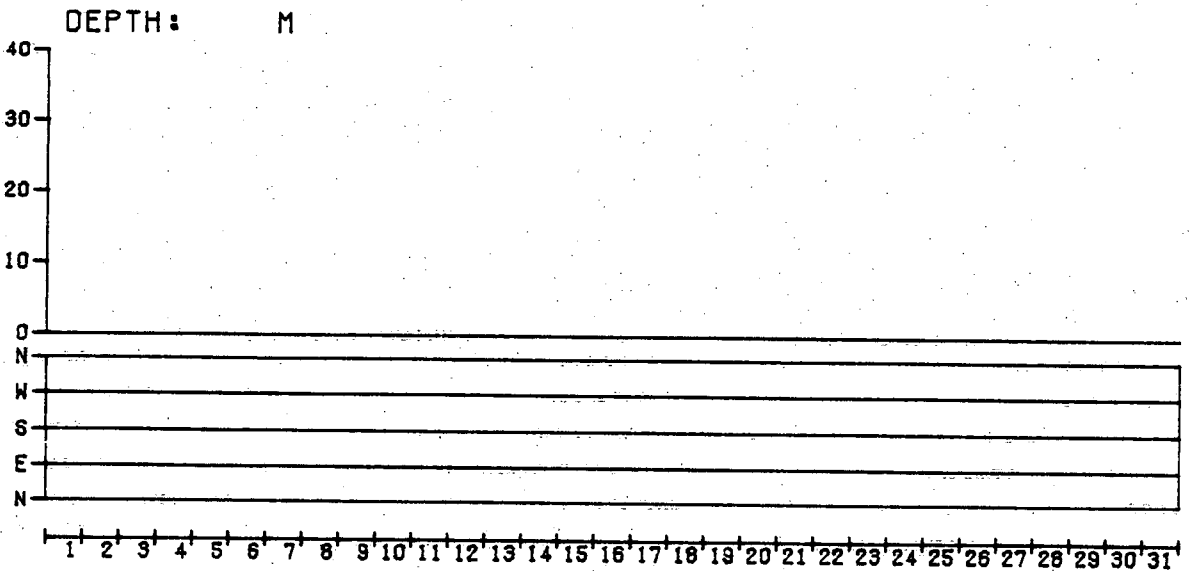
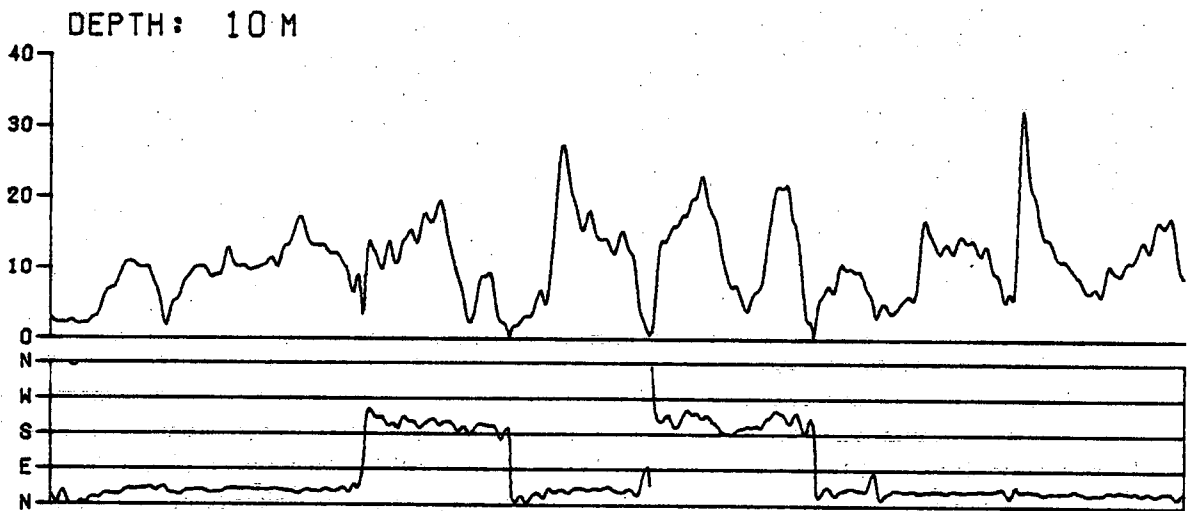

MOORING: 31

DATE: JAN 1974

TEMPERATURE °C

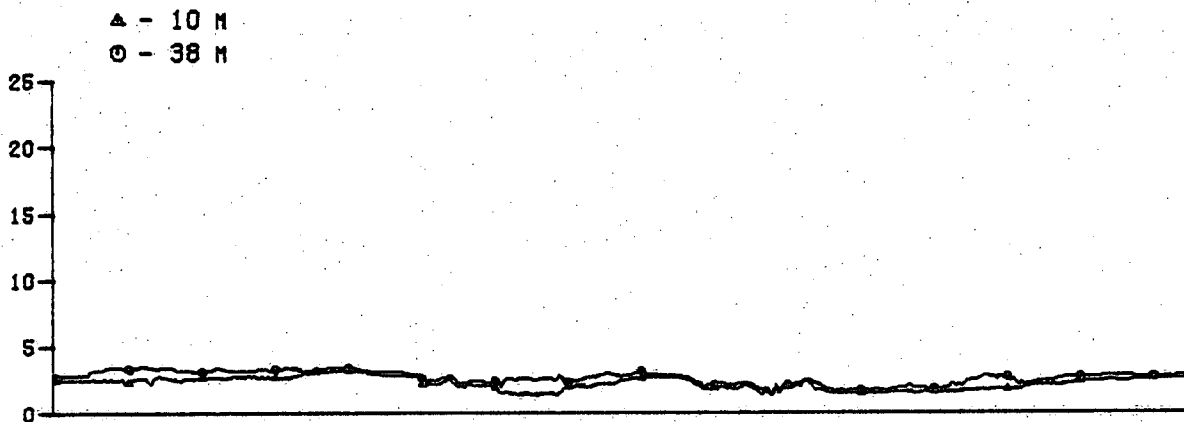

FILTERED CURRENT (0.0 TO 0.2 CPH) CM/SEC

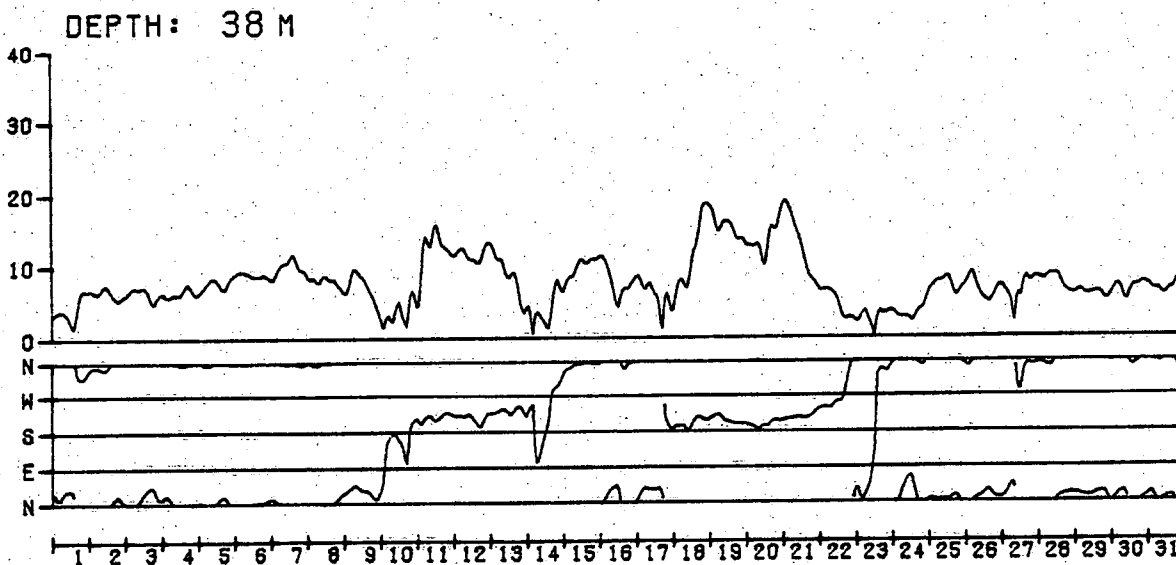
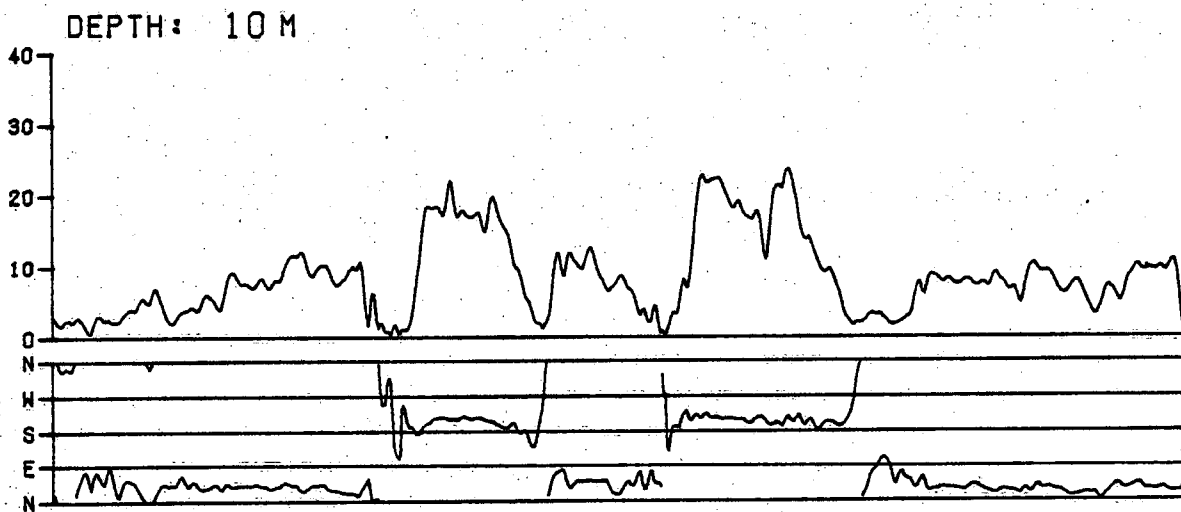

MOORING : 32

DATE : JAN 1974

TEMPERATURE °C

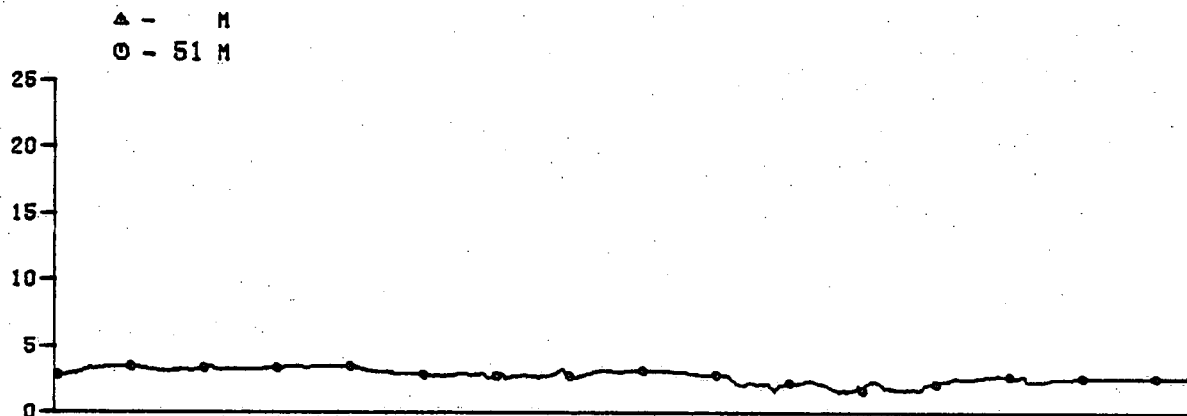

FILTERED CURRENT (0.0 TO 0.2 CPH) CM/SEC

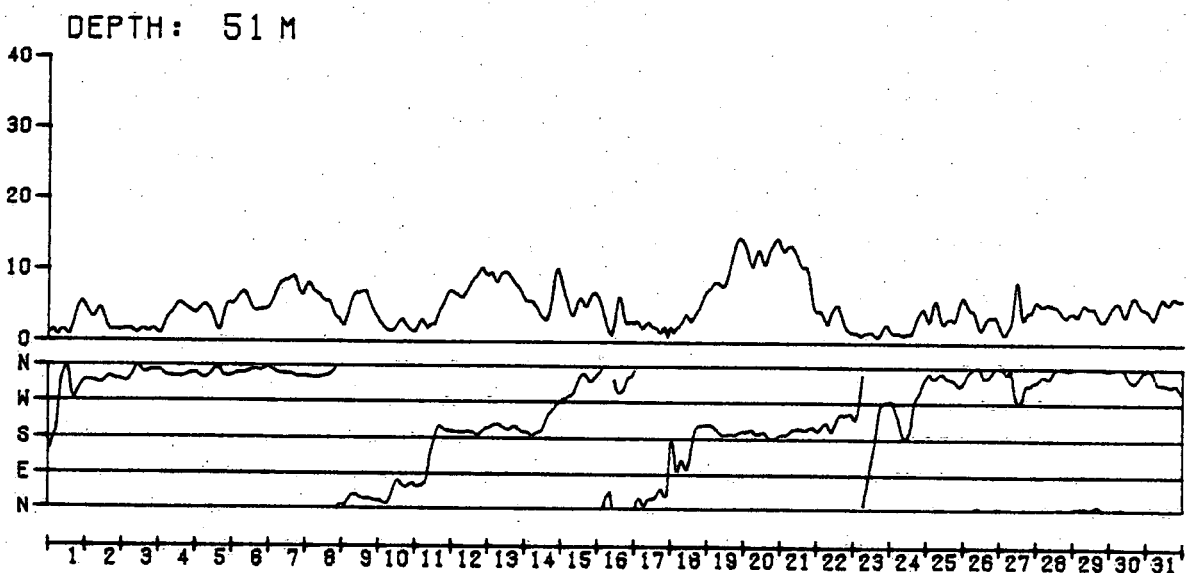
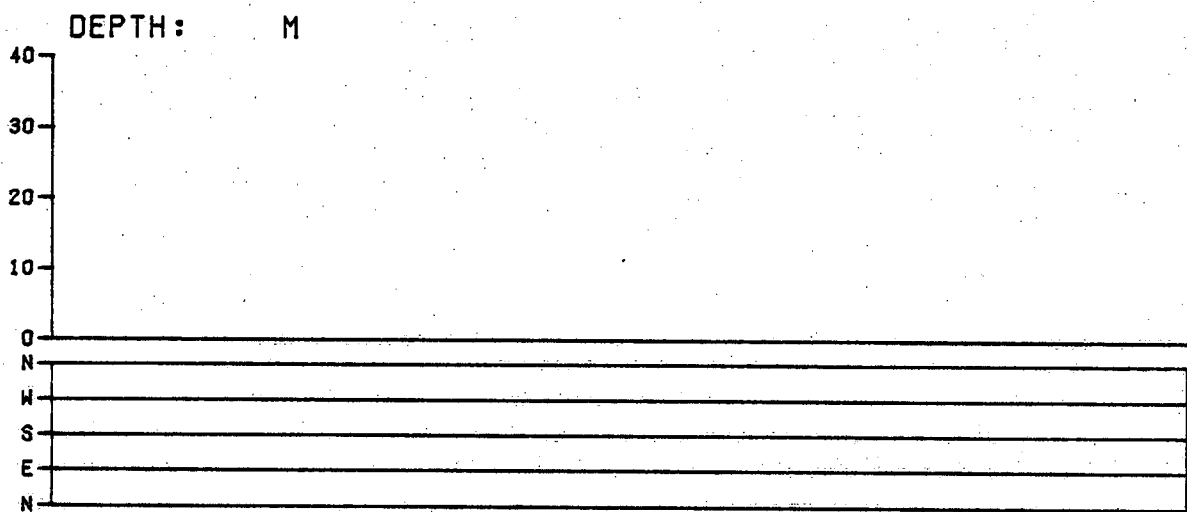

MOORING: 33

DATE: JAN 1974

TEMPERATURE °C

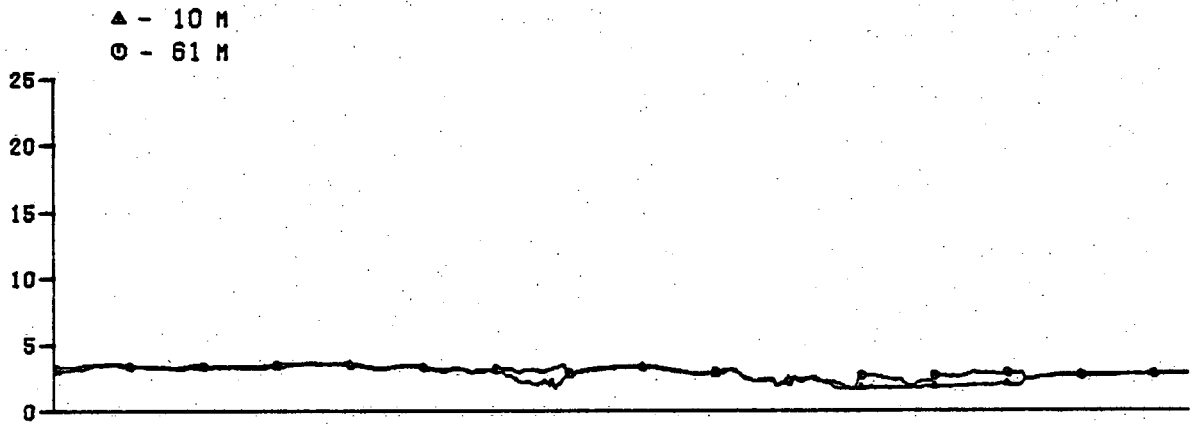

FILTERED CURRENT (0.0 TO 0.2 CPH) CM/SEC

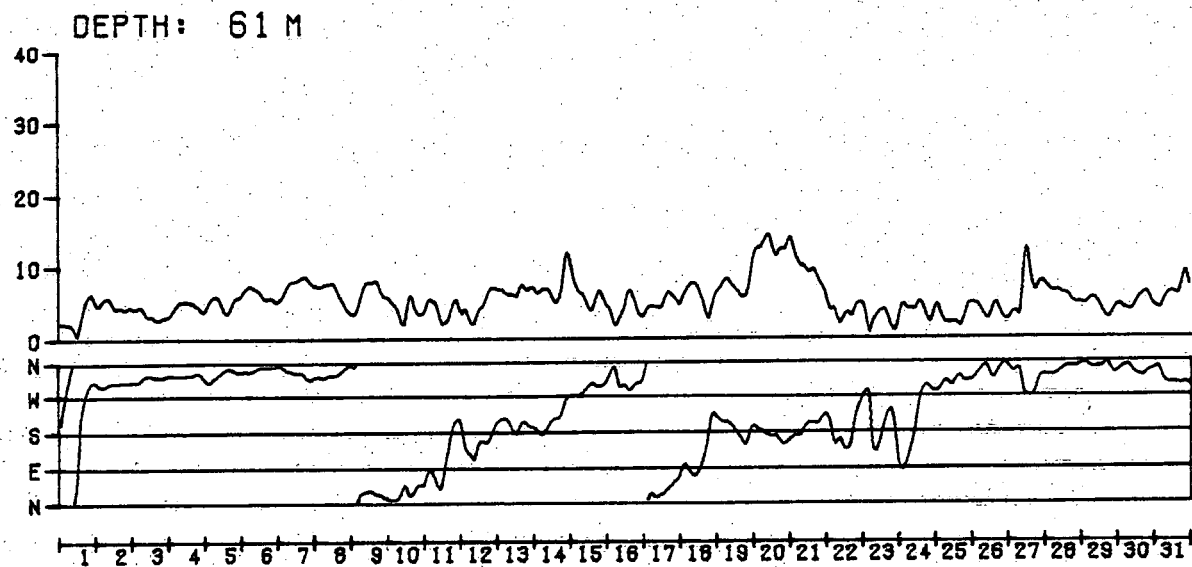
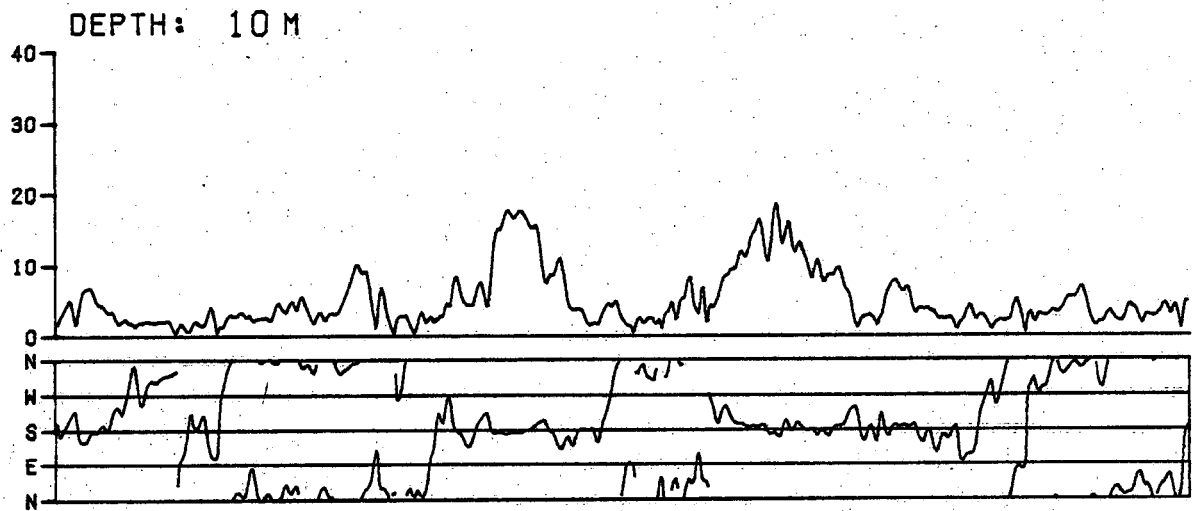



MOORING: 34

DATE: JAN 1974

TEMPERATURE °C

▲ - 10 M  
○ - 63 M

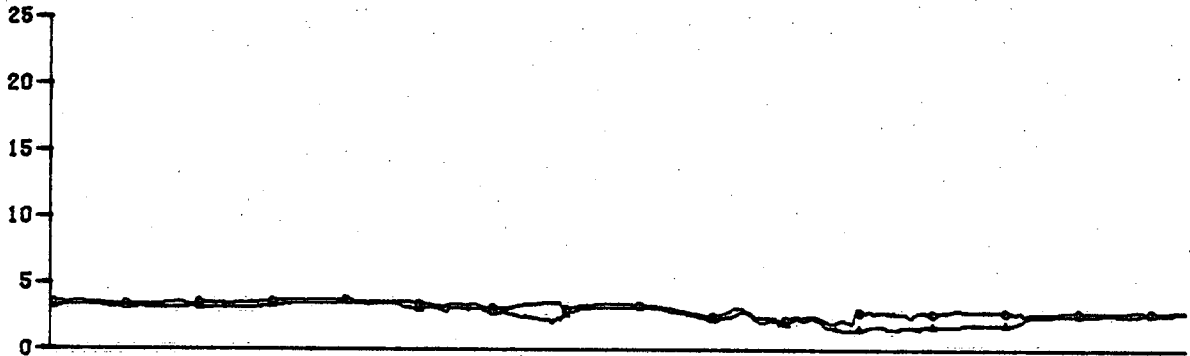

FILTERED CURRENT (0.0 TO 0.2 CPH) CM/SEC

DEPTH: 10 M

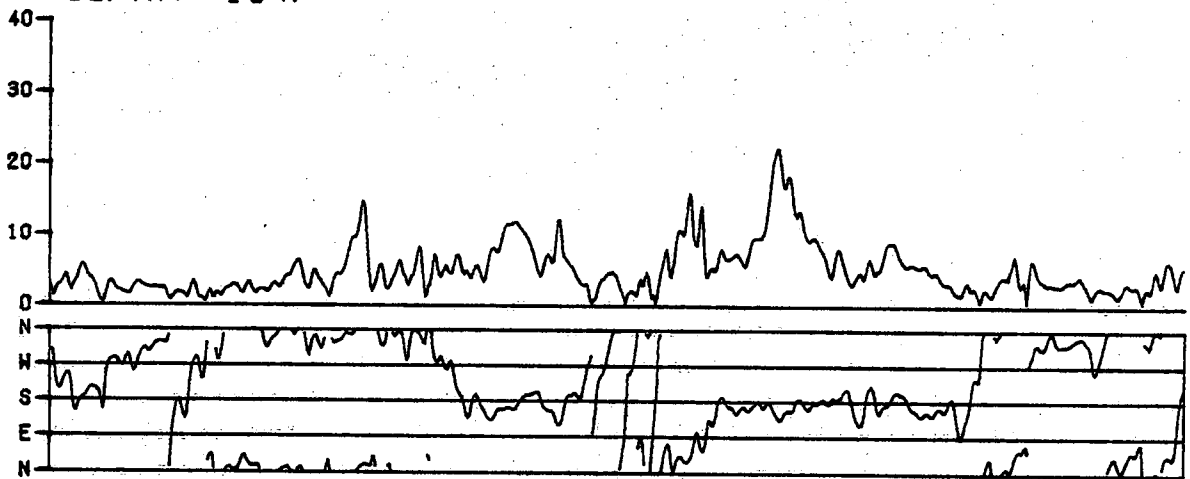

DEPTH: 63 M

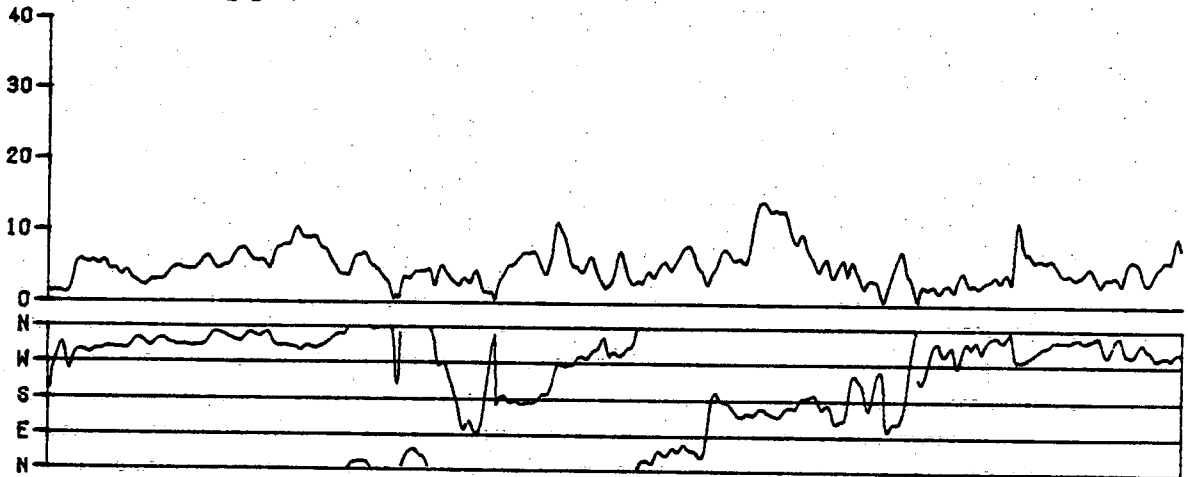

1' 2' 3' 4' 5' 6' 7' 8' 9' 10' 11' 12' 13' 14' 15' 16' 17' 18' 19' 20' 21' 22' 23' 24' 25' 26' 27' 28' 29' 30' 31'

MOORING: 30

DATE: FEB 1974

TEMPERATURE °C

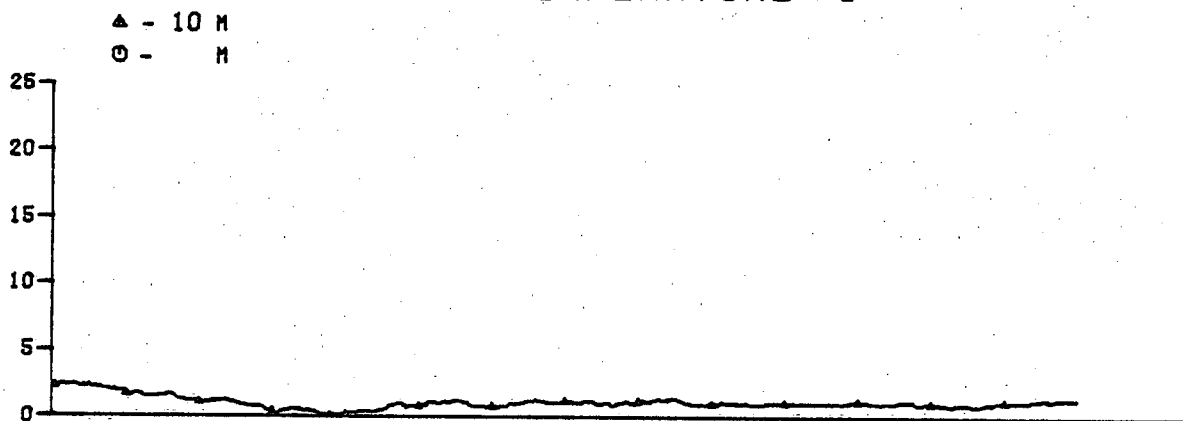

FILTERED CURRENT (0.0 TO 0.2 CPH) CM/SEC

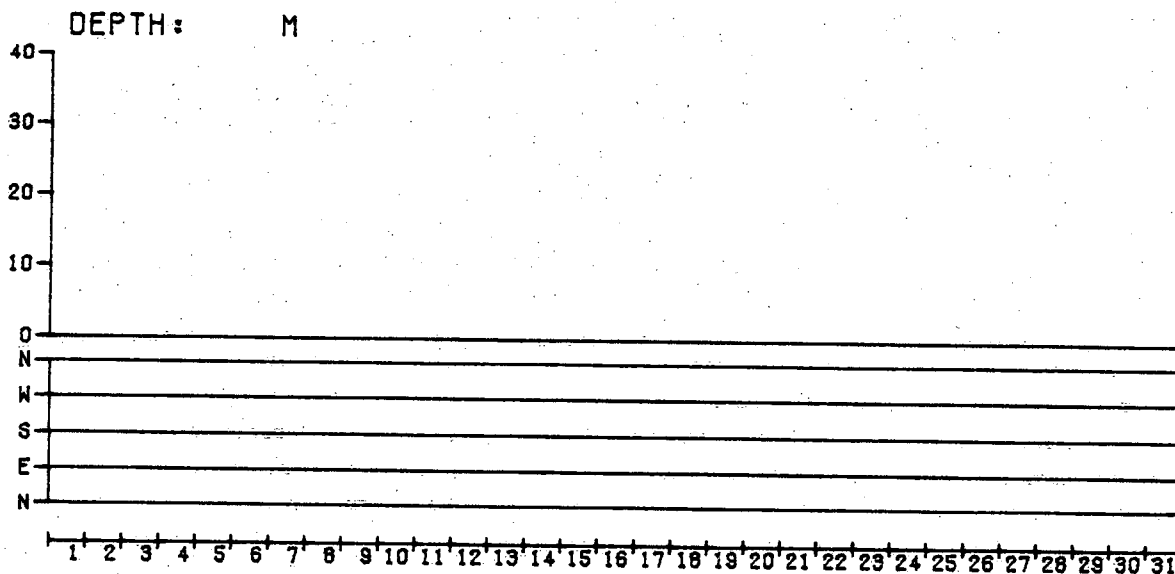
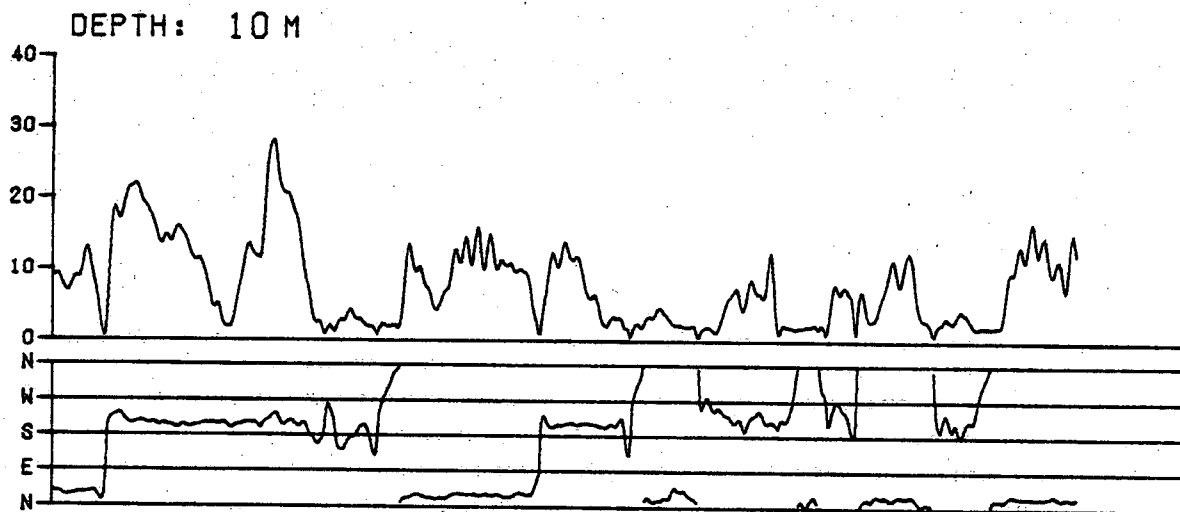

MOORING: 31

DATE: FEB 1974

TEMPERATURE °C

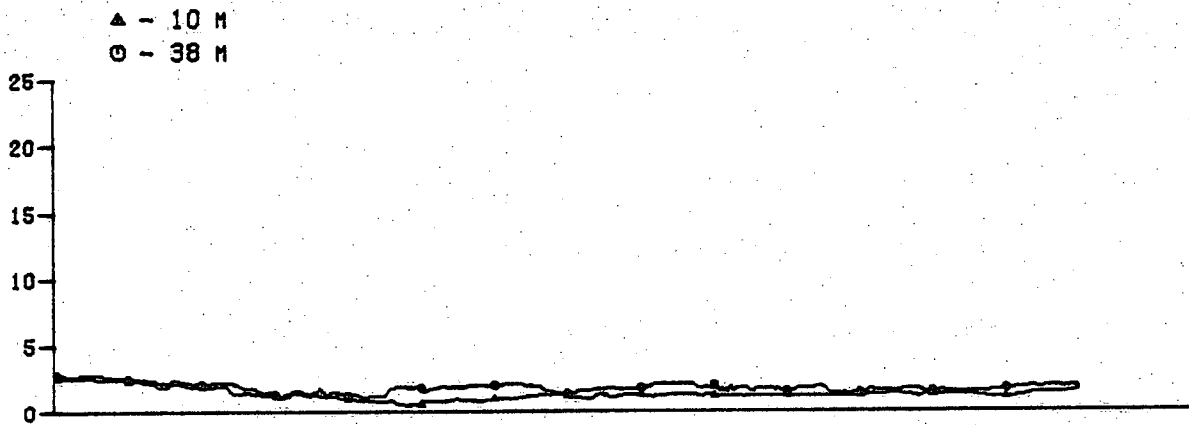

FILTERED CURRENT (0.0 TO 0.2 CPH) CM/SEC

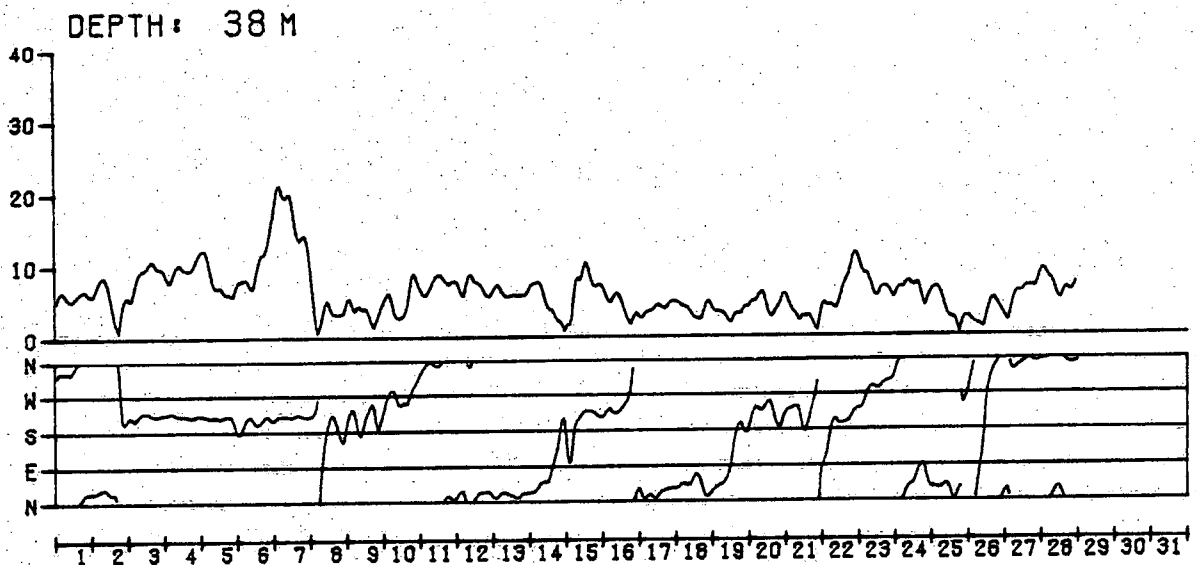
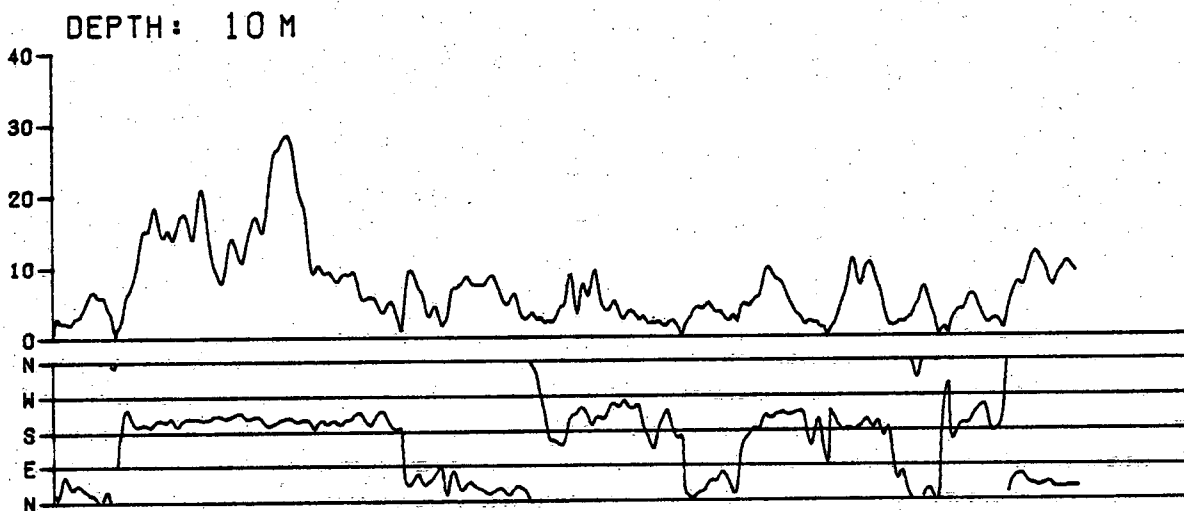

MOORING: 32

DATE: FEB 1974

TEMPERATURE °C

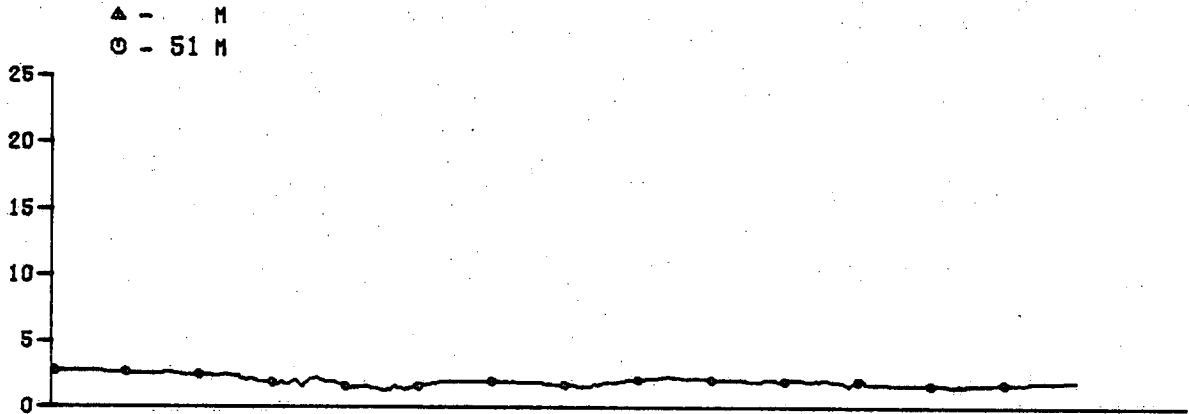

FILTERED CURRENT (0.0 TO 0.2 CPH) CM/SEC

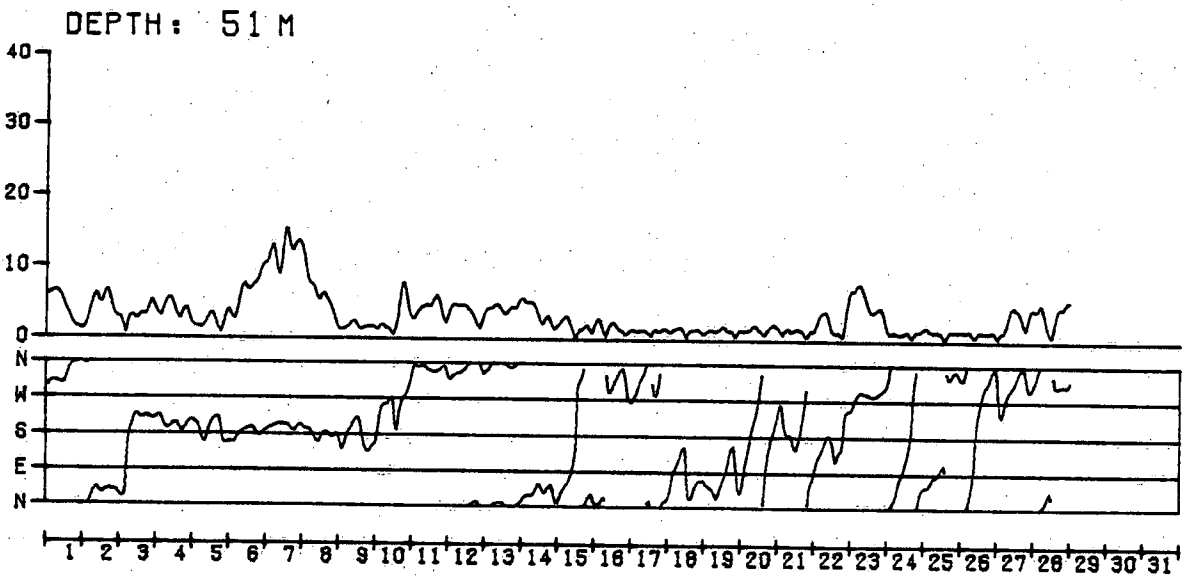
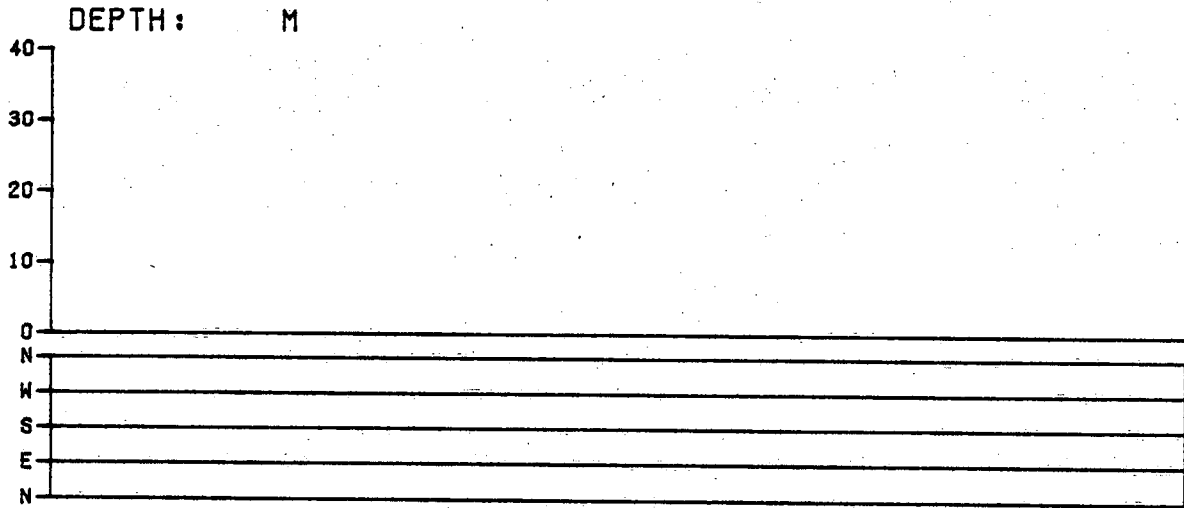

MOORING : 33

DATE : FEB 1974

TEMPERATURE °C

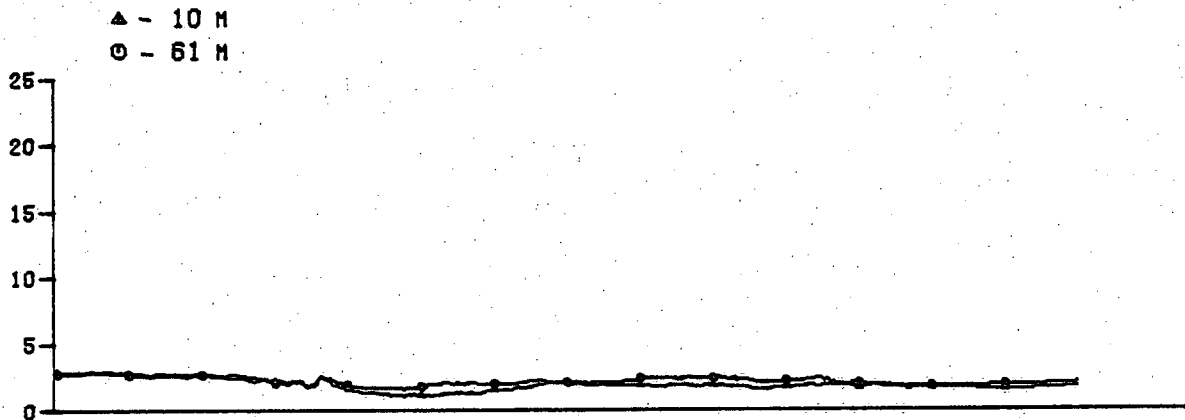

FILTERED CURRENT (0.0 TO 0.2 CPH) CM/SEC

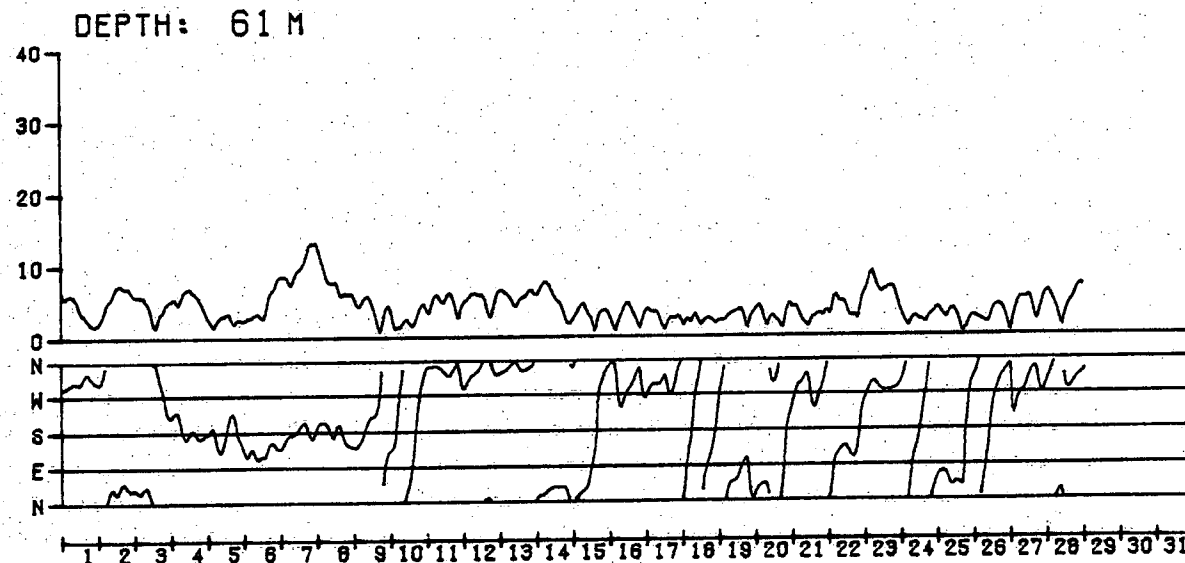
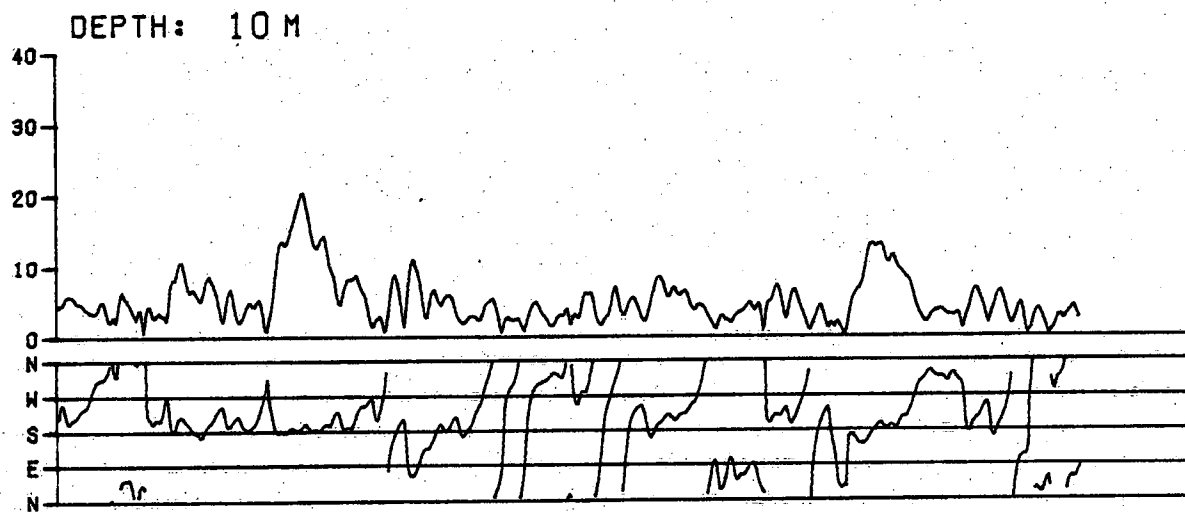

MOORING: 34

DATE: FEB 1974

TEMPERATURE °C

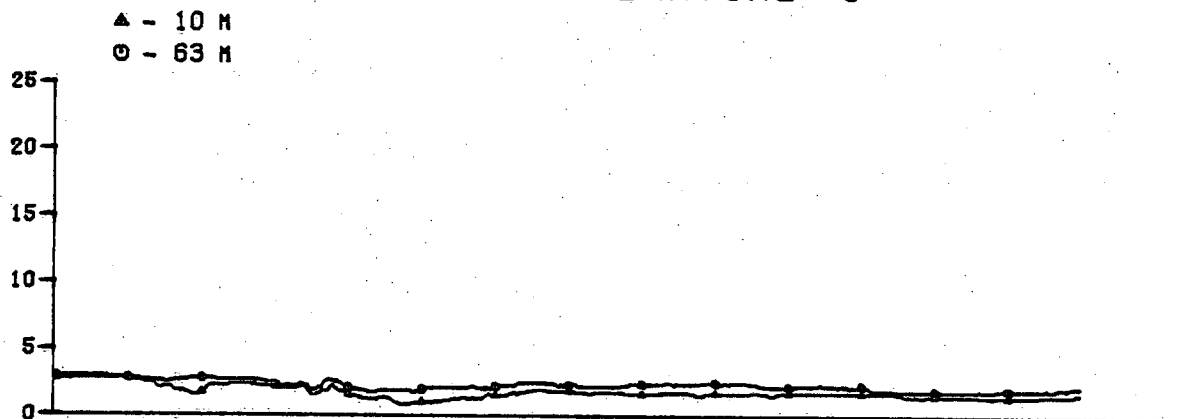

FILTERED CURRENT (0.0 TO 0.2 CPH) CM/SEC

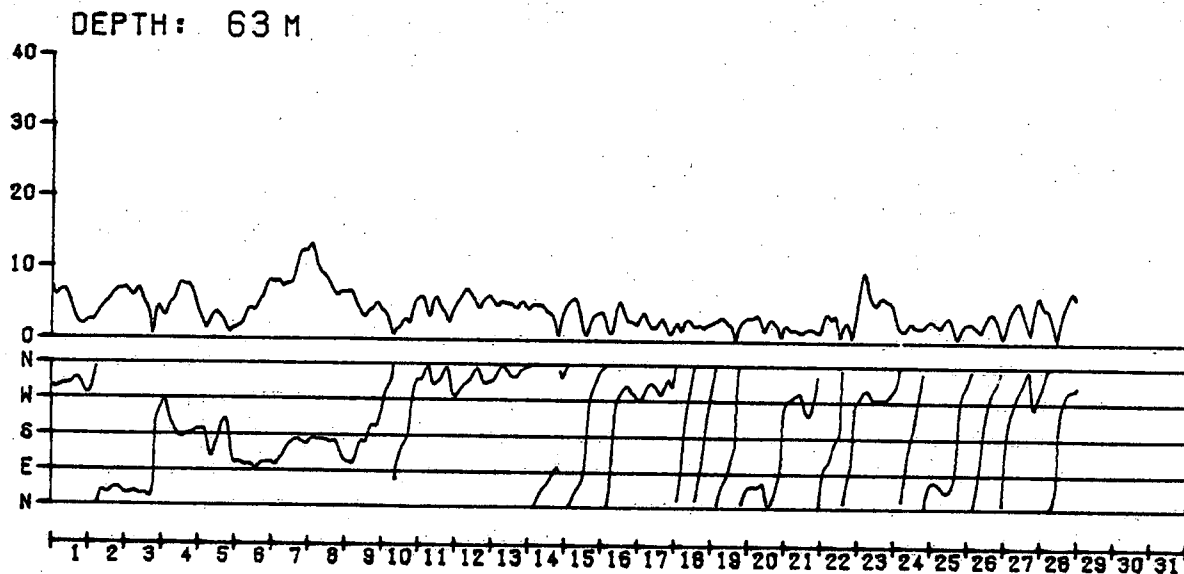
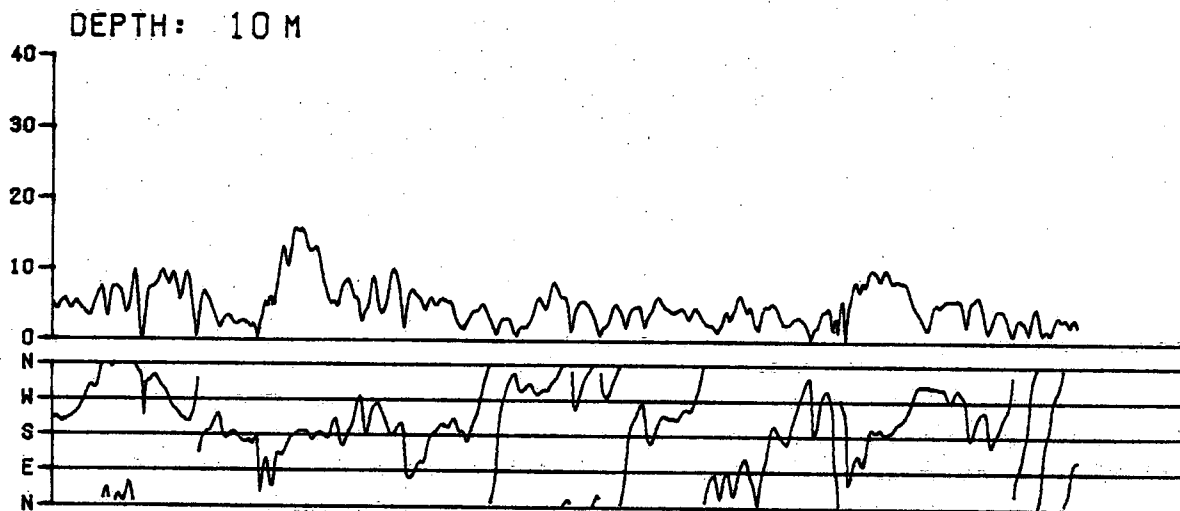

MOORING: 30

DATE: MAR 1974

TEMPERATURE °C

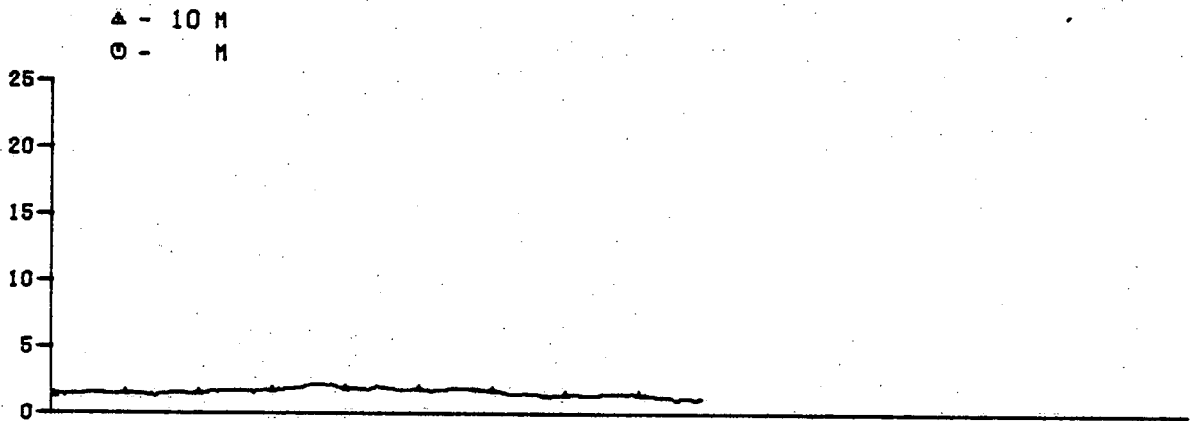

FILTERED CURRENT (0.0 TO 0.2 CPH) CM/SEC

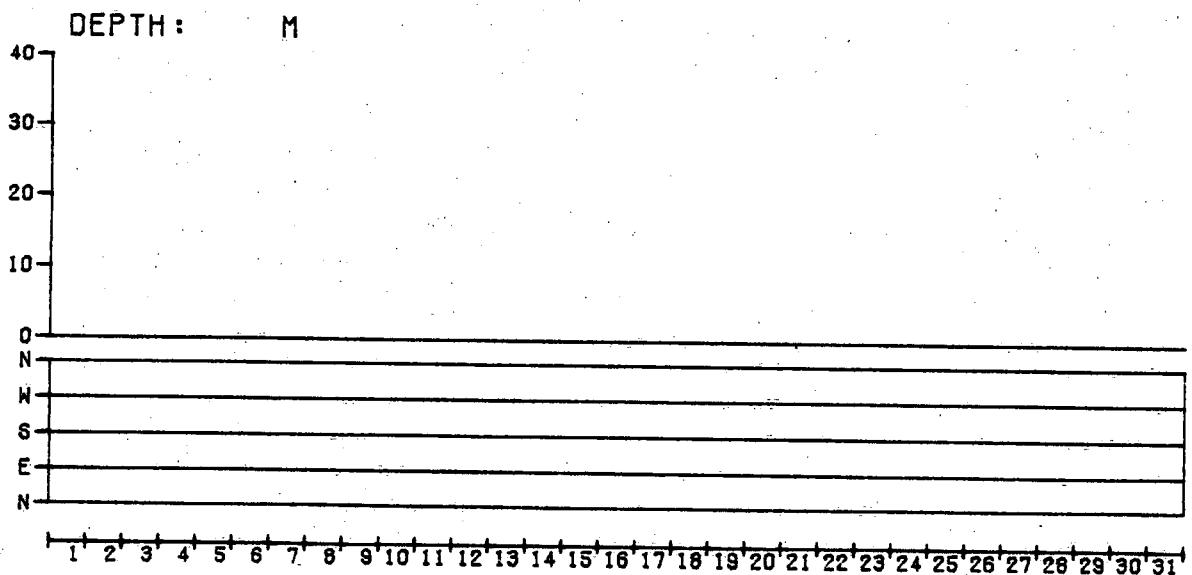
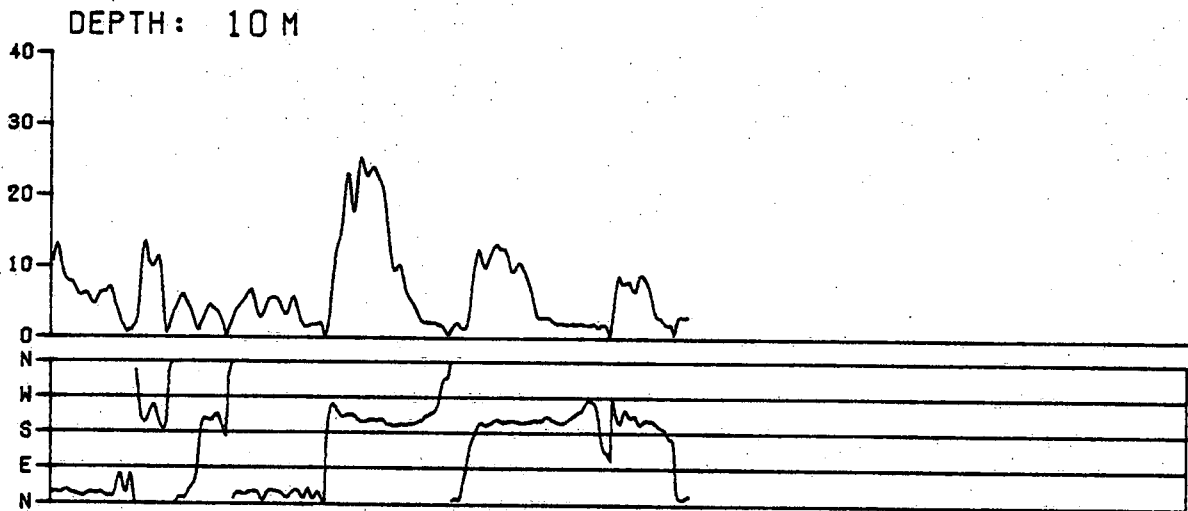

MOORING: 31

DATE: MAR 1974

TEMPERATURE °C

△ - 10 M  
○ - 38 M

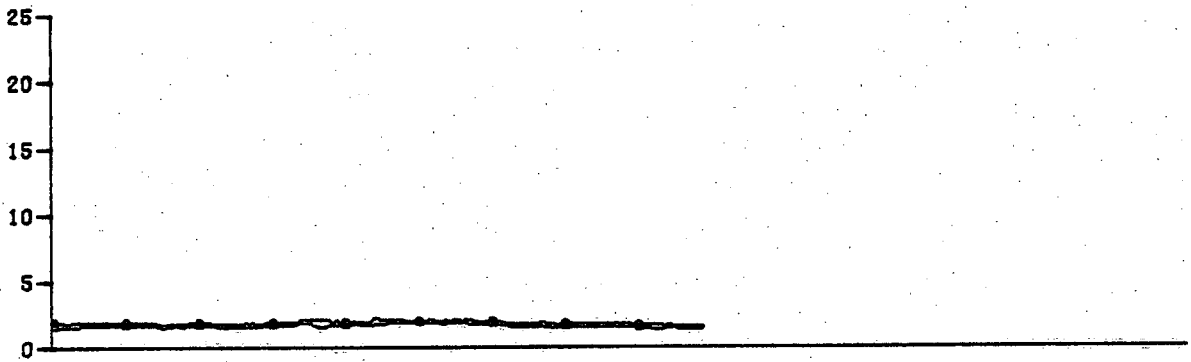

FILTERED CURRENT (0.0 TO 0.2 CPH) CM/SEC

DEPTH: 10 M

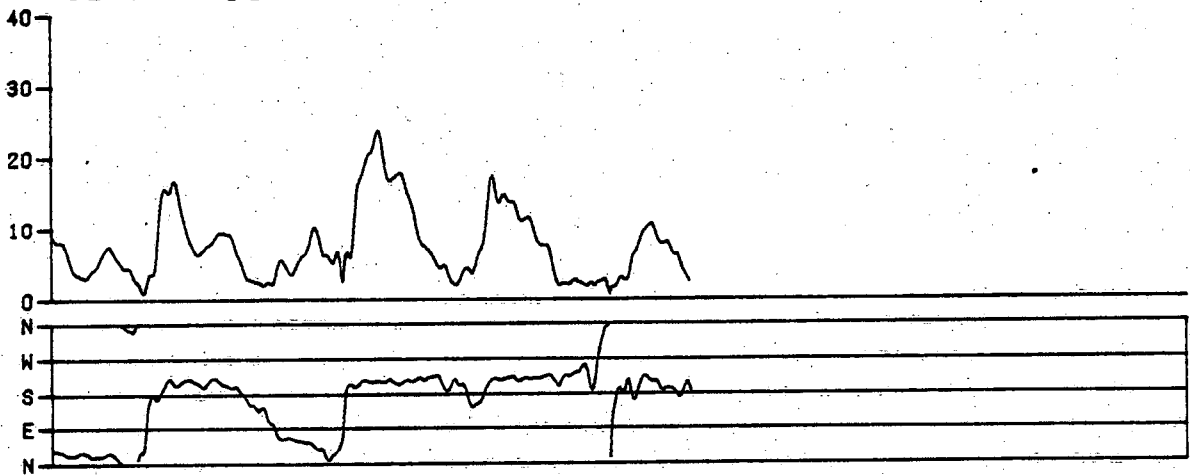

DEPTH: 38 M

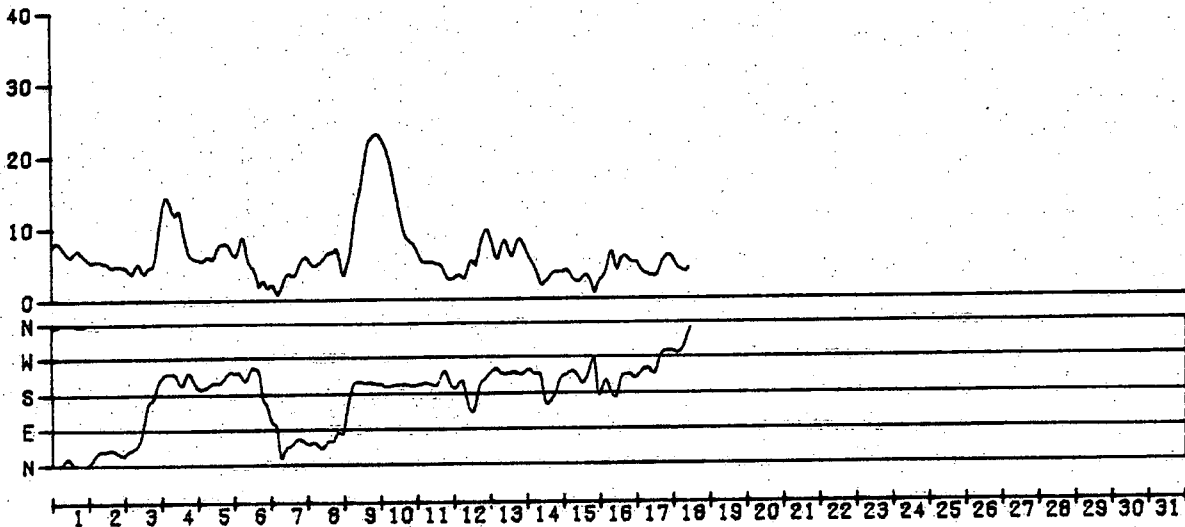

1 2 3 4 5 6 7 8 9 10 11 12 13 14 15 16 17 18 19 20 21 22 23 24 25 26 27 28 29 30 31



MOORING : 32

DATE : MAR 1974

TEMPERATURE °C

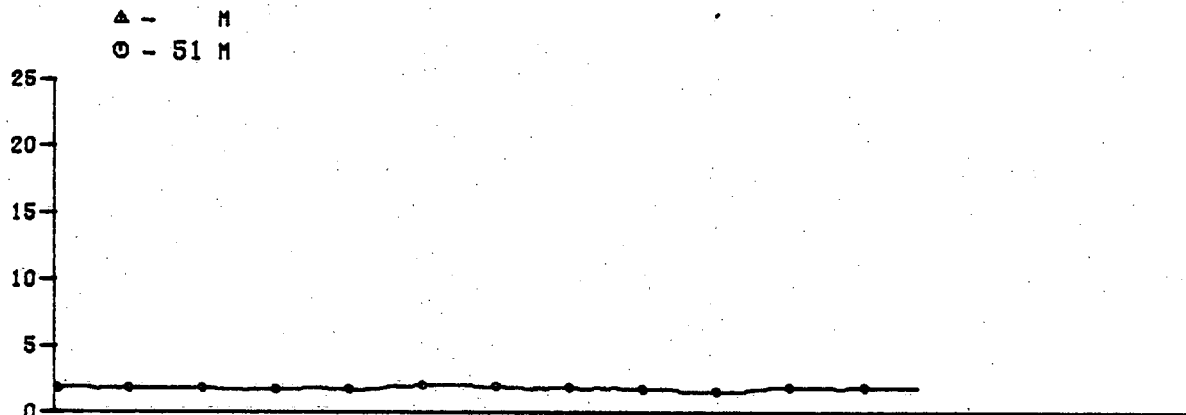

FILTERED CURRENT (0.0 TO 0.2 CPH) CM/SEC

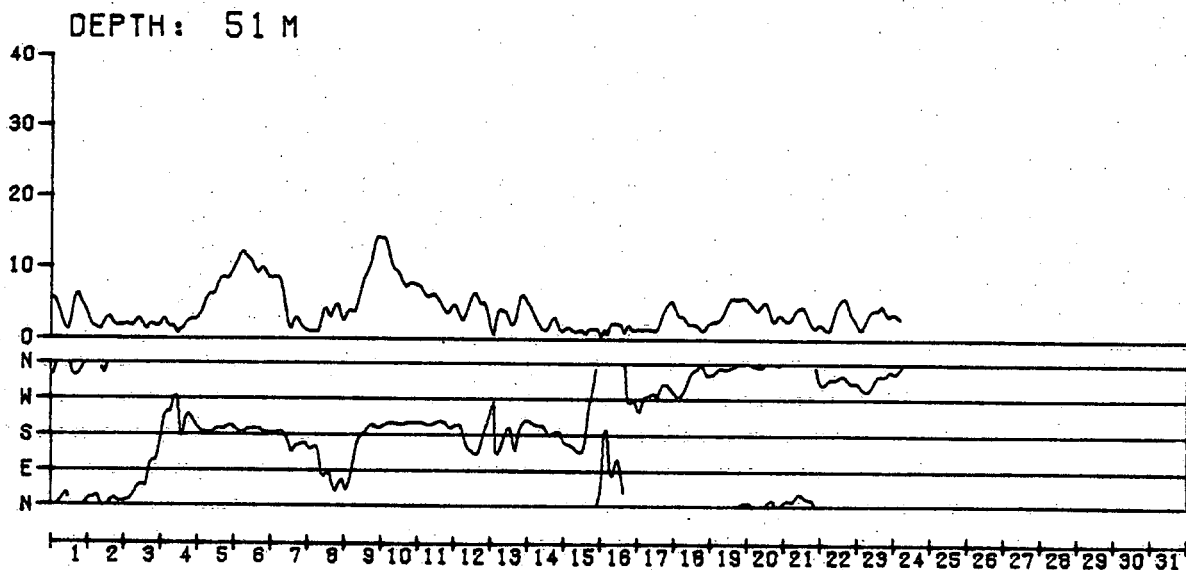
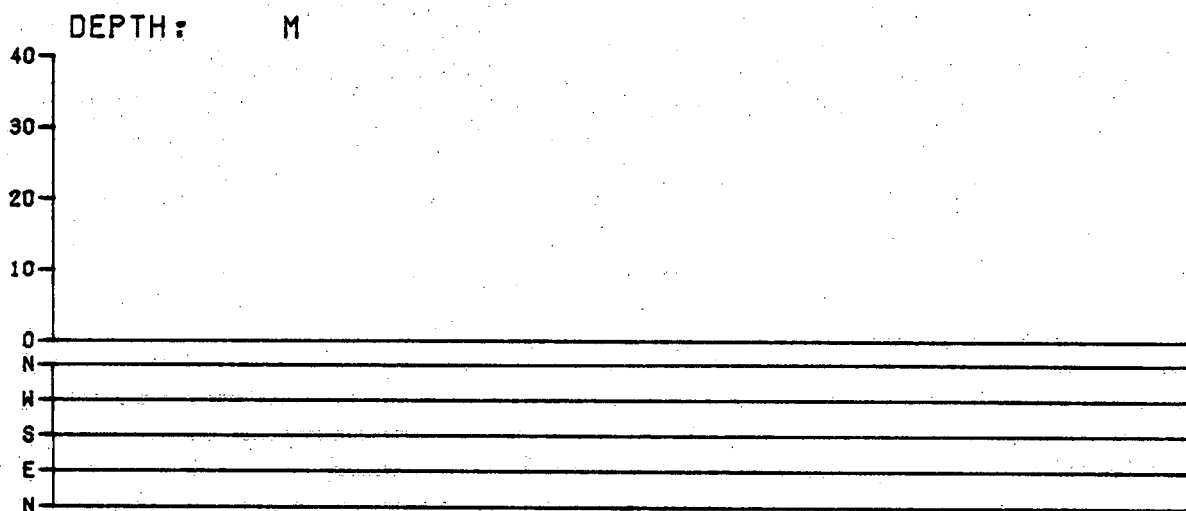

MOORING : 33

DATE : MAR 1974

TEMPERATURE °C

△ - 10 M  
⊙ - 61 M

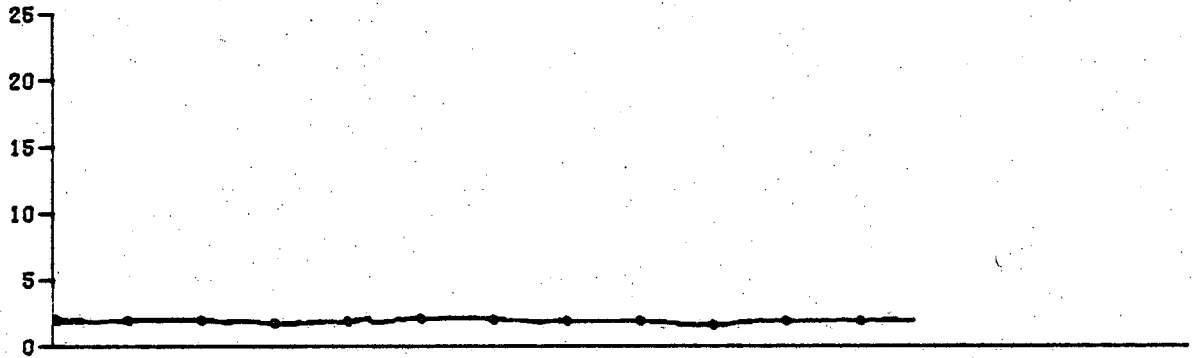

FILTERED CURRENT (0.0 TO 0.2 CPH) CM/SEC

DEPTH: 10 M

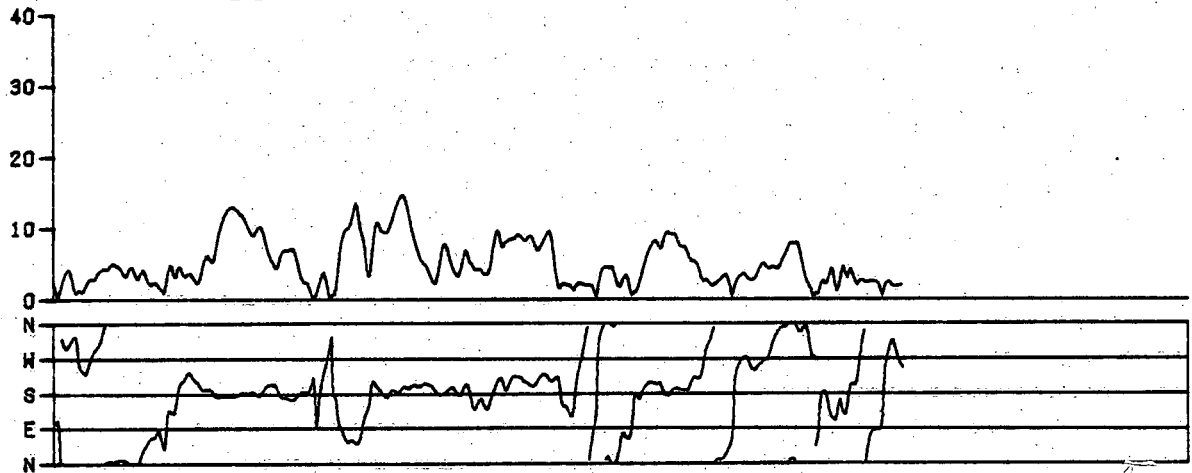

DEPTH: 61 M

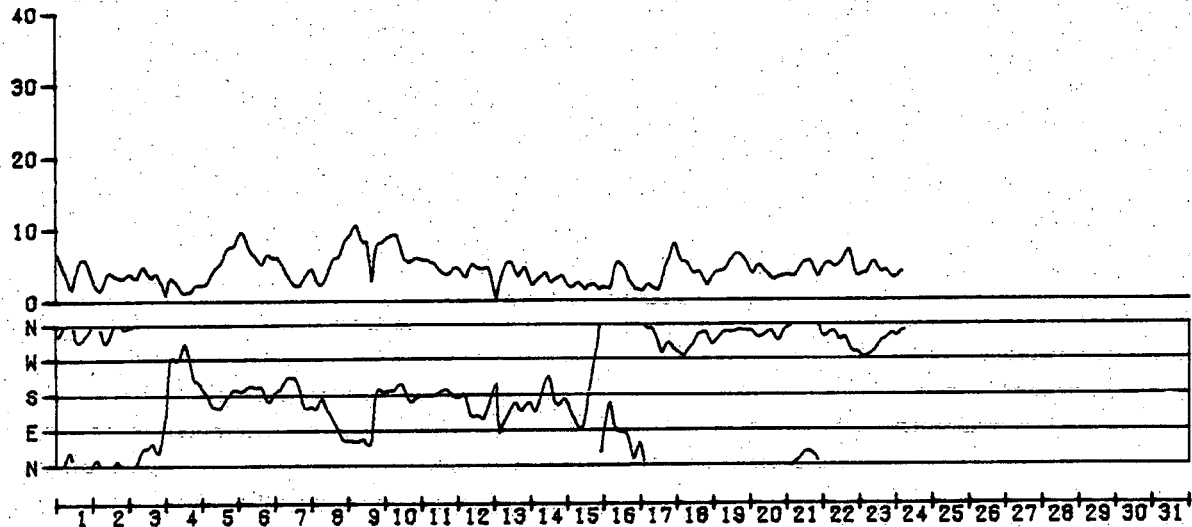

MOORING: 34

DATE: MAR 1974

TEMPERATURE °C

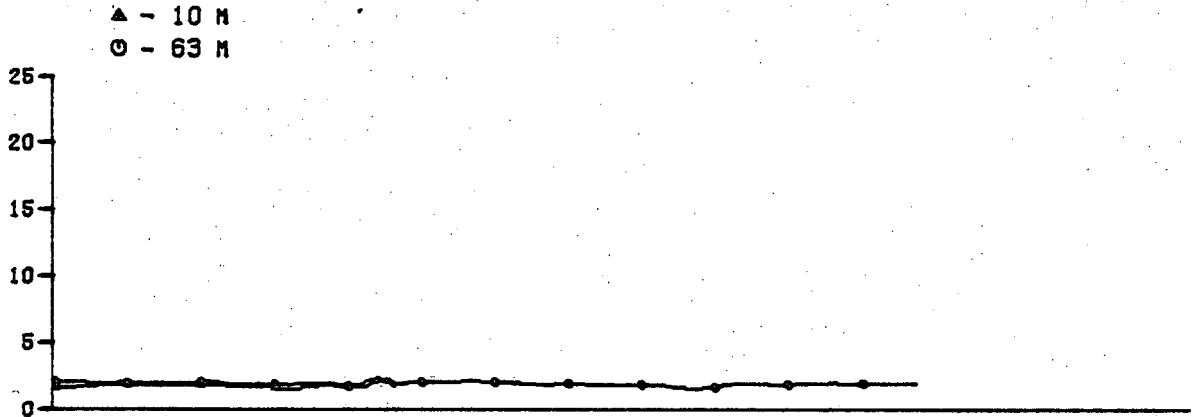

FILTERED CURRENT (0.0 TO 0.2 CPH) CM/SEC

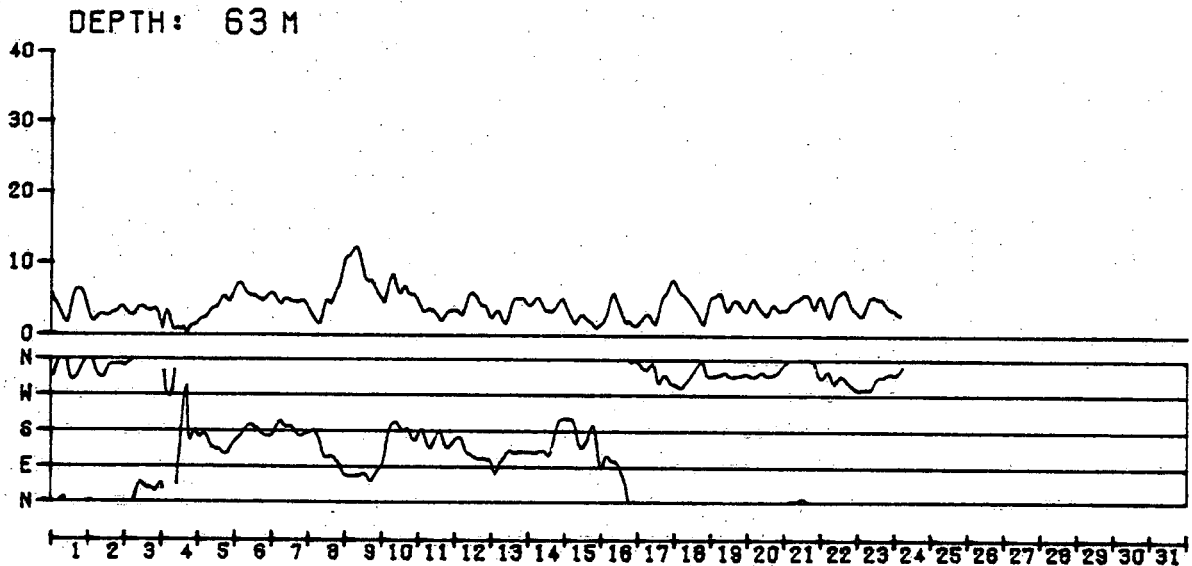
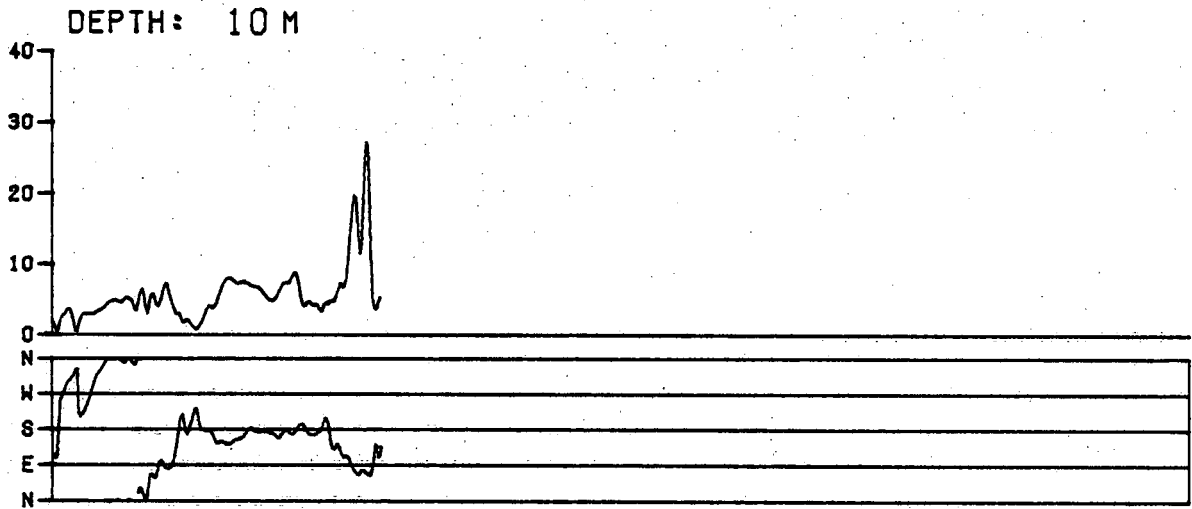

APPENDIX D: PROGRESSIVE VECTOR DIAGRAMS

# Current PVD's

Deep Meters

June 1973

2300 GMT

30 JUNE 1973

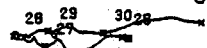

MOORING: 23 DEPTH: 30M

2300 GMT

25 JUNE 1973

2300 GMT

30 JUNE 1973

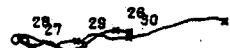

MOORING: 22 DEPTH: 27M

2200 GMT

25 JUNE 1973

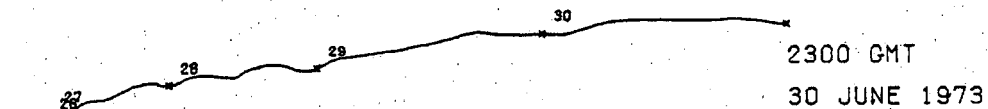

MOORING: 21 DEPTH: 16M

2100 GMT

25 JUNE 1973

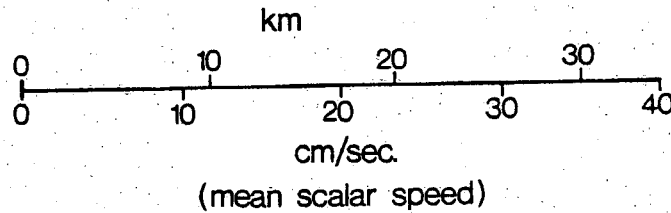
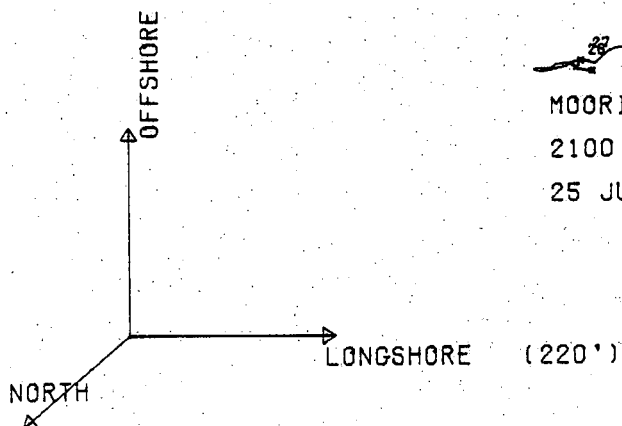

Shallow Meters

# Current PVD's

June 1973

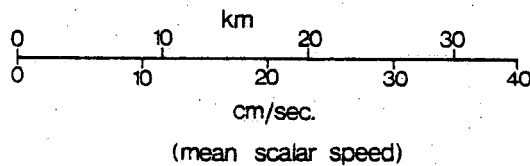
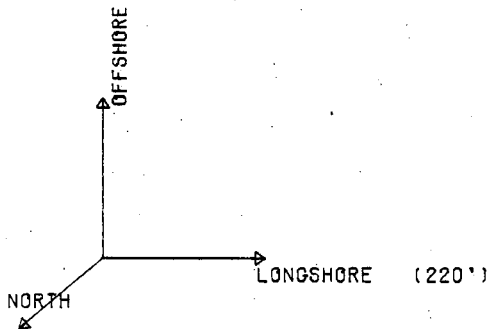
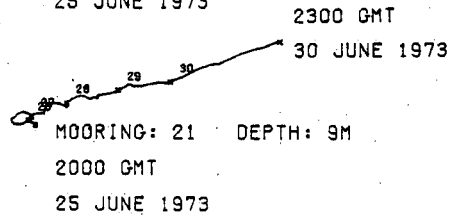
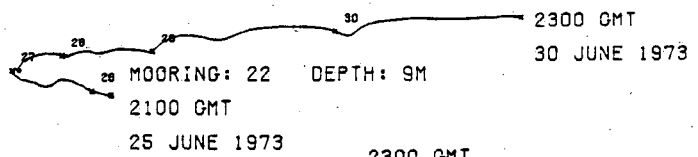
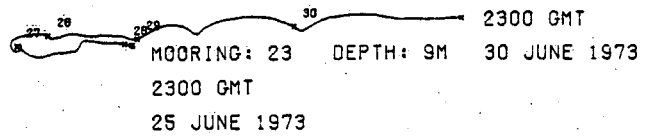
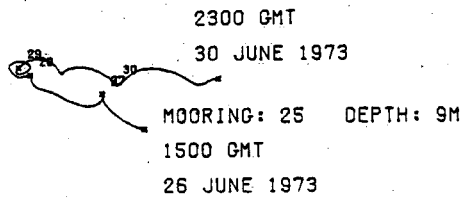
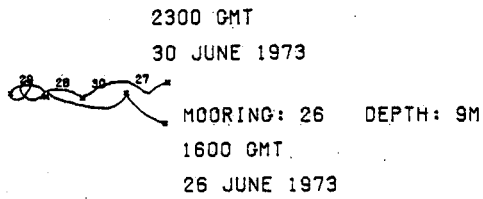
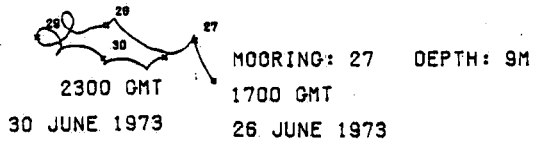
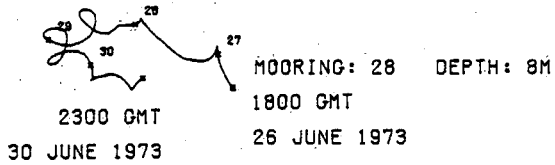

# Current PVD's

July 1973

Deep Meters

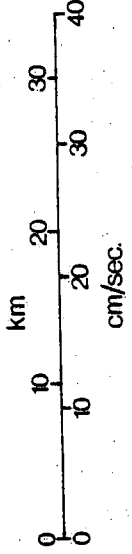
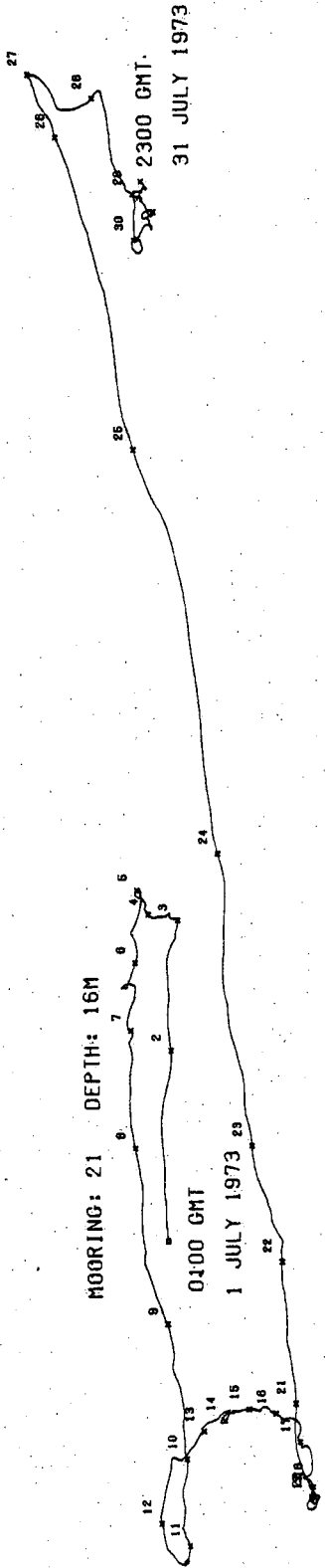
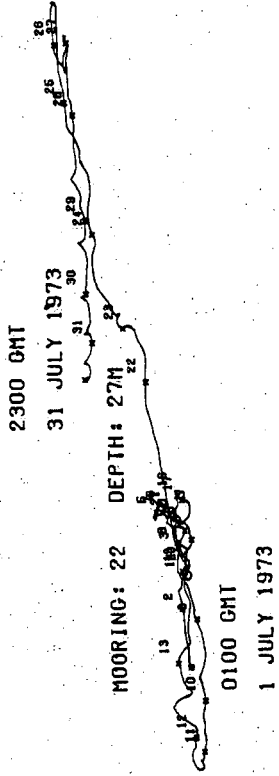
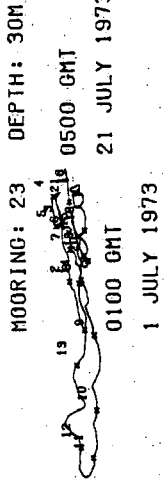
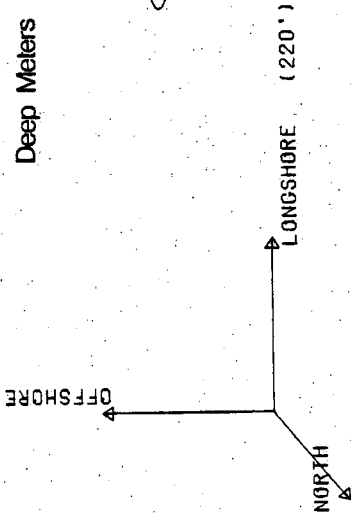

Current PVD's

Shallow Meters

July 1973

2300 GMT  
31 JULY 1973

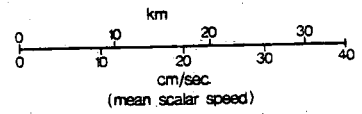
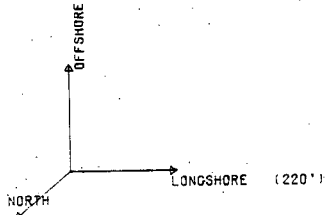

MOORING: 28 DEPTH: 8M  
0100 GMT  
1 JULY 1973

MOORING: 27 DEPTH: 9M  
0100 GMT  
1 JULY 1973

MOORING: 25 DEPTH: 9M  
0100 GMT  
1 JULY 1973

MOORING: 25 DEPTH: 9M  
0100 GMT  
1 JULY 1973

0100 GMT  
1 JULY 1973

MOORING: 23 DEPTH: 9M

MOORING: 22 DEPTH: 9M  
0100 GMT  
1 JULY 1973

1700 GMT  
8 JULY 1973

MOORING: 21 DEPTH: 9M  
0100 GMT  
1 JULY 1973

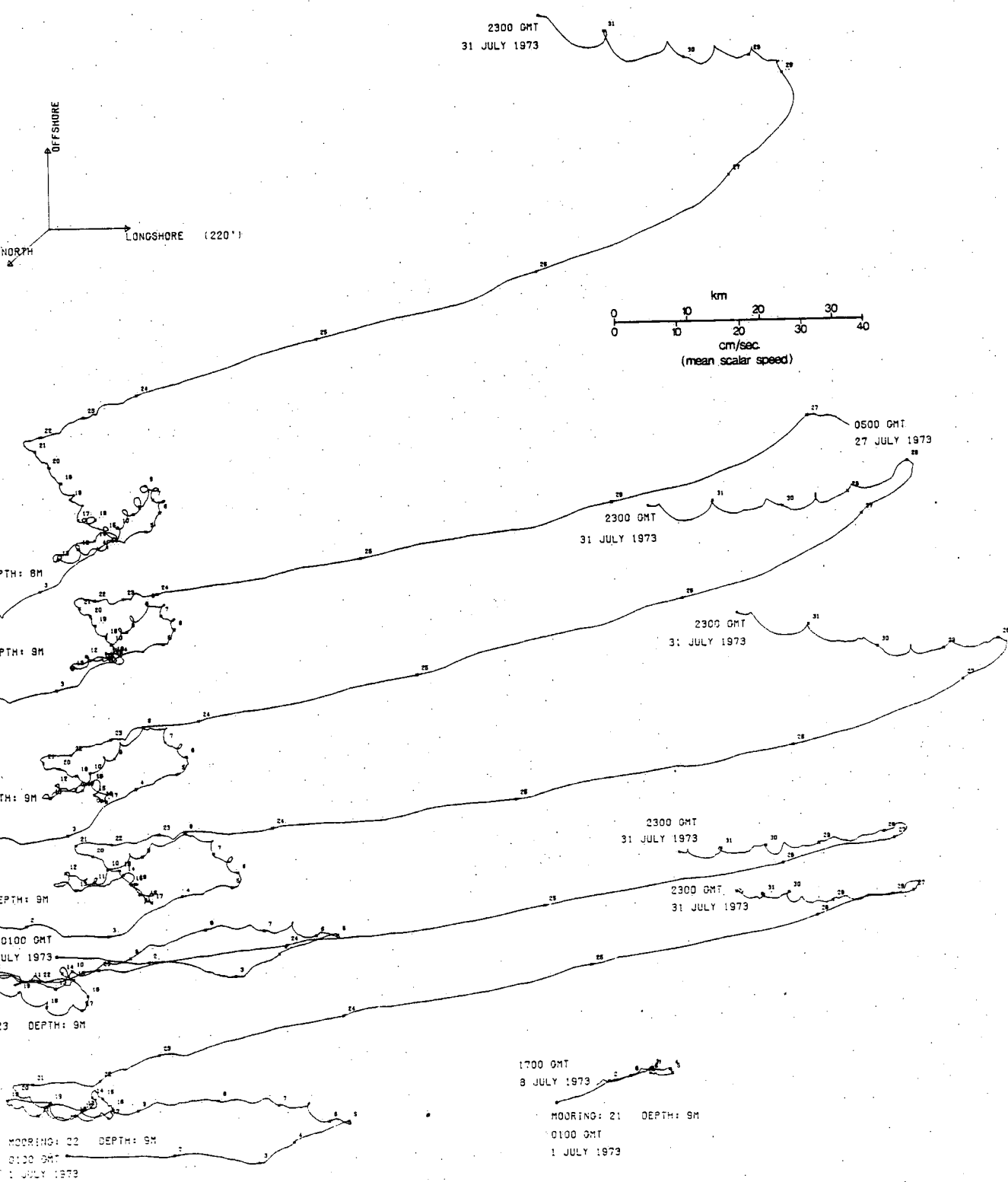



# Current PVD's

Deep Meters

Aug. 1973

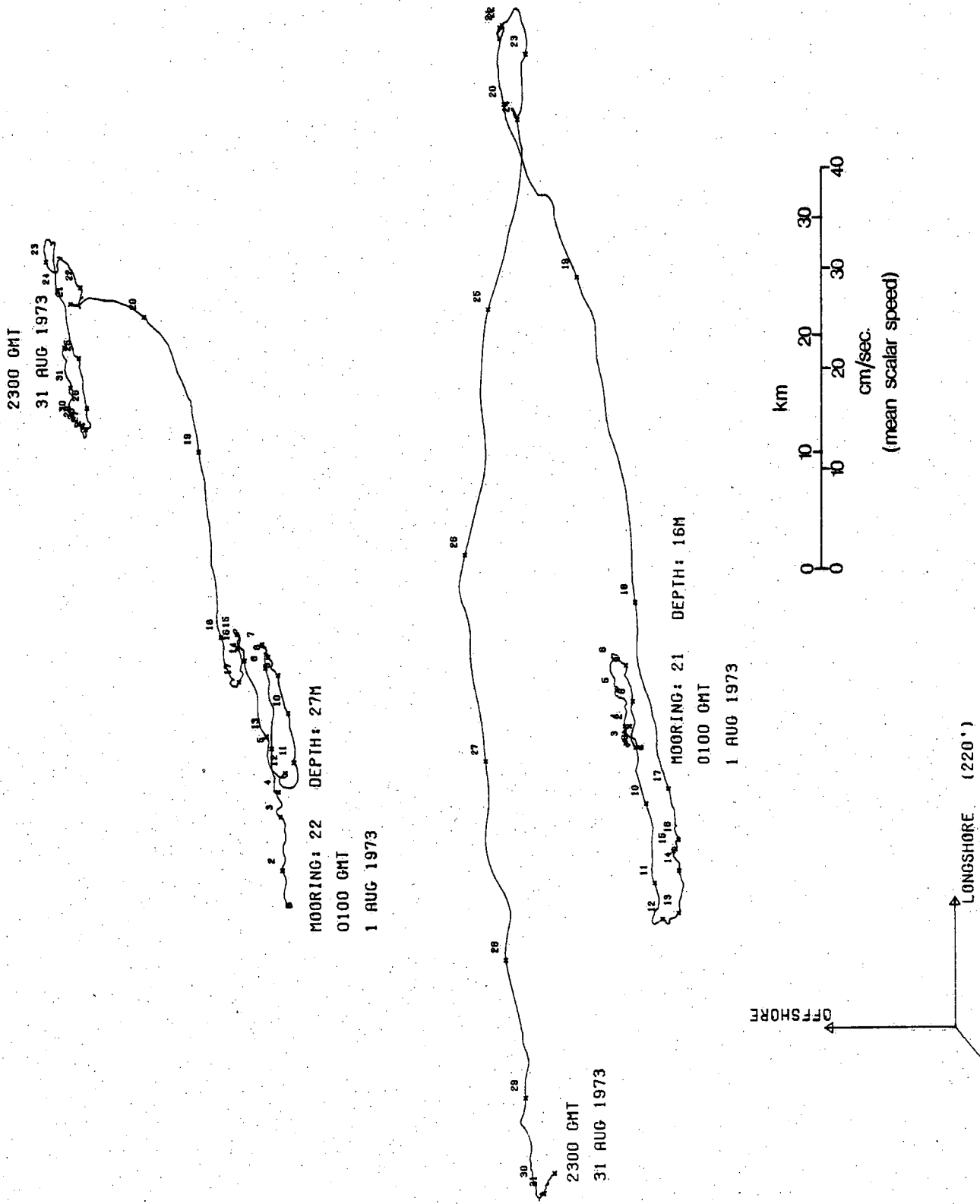

# Current PVD's

Shallow Meters

Aug. 1973

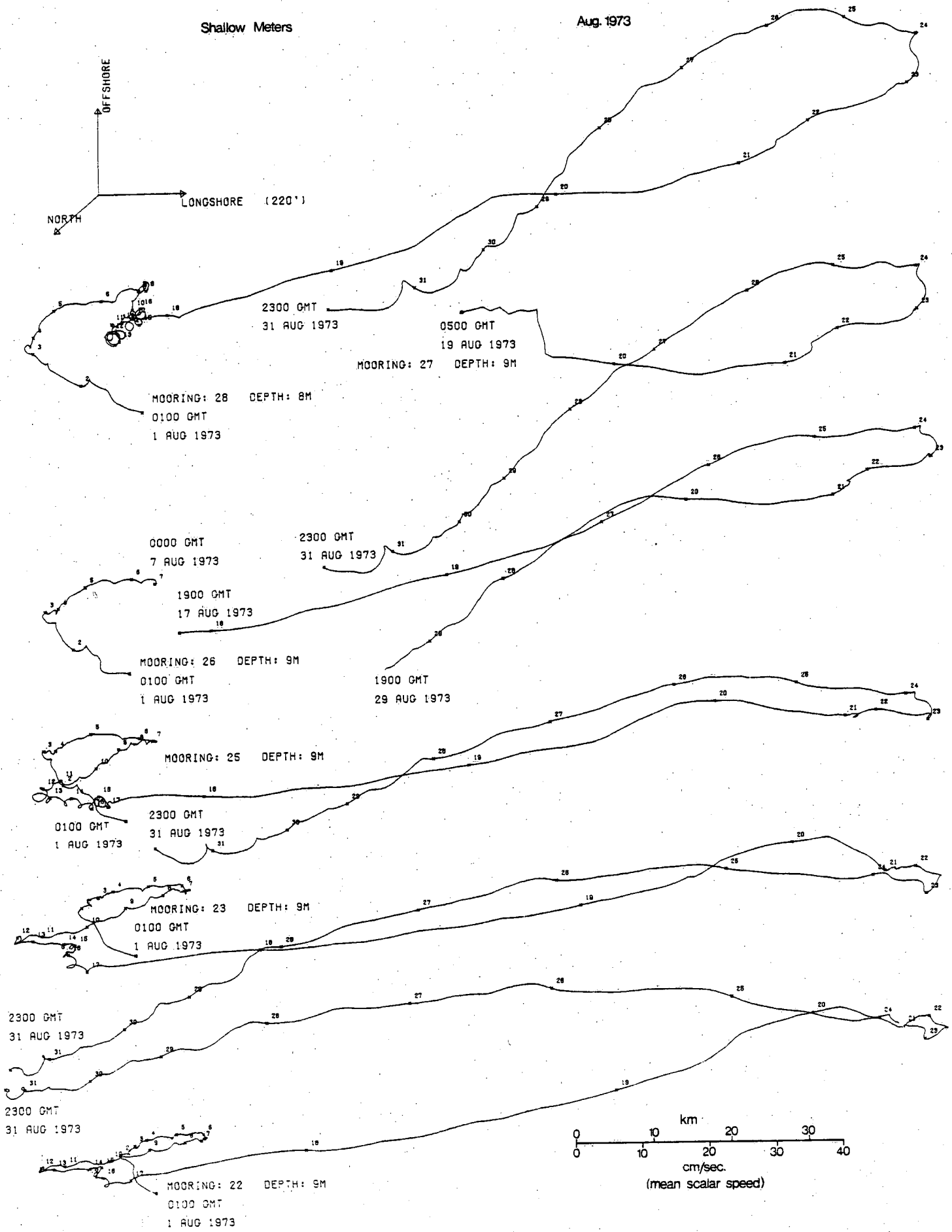

# Current PVD's

Deep Meters

Sept. 1973

1700 GMT  
7 SEPT 1973

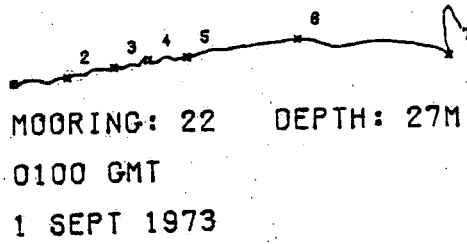

MOORING: 21 DEPTH: 16M  
0100 GMT  
1 SEPT 1973

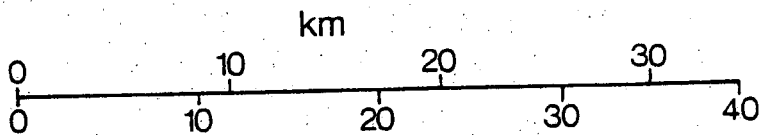
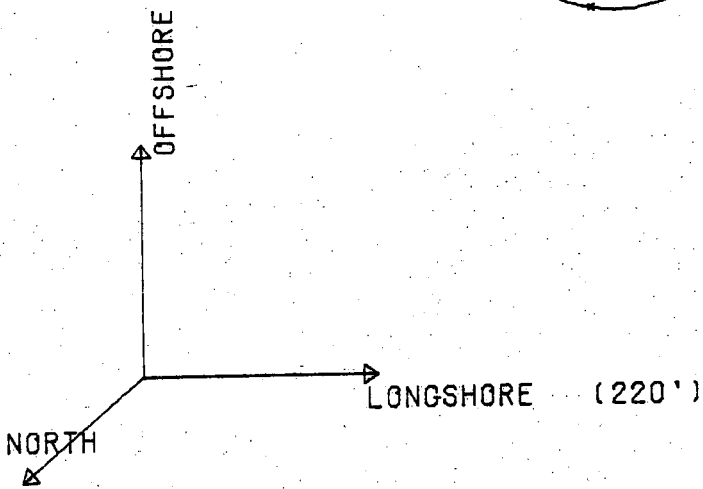
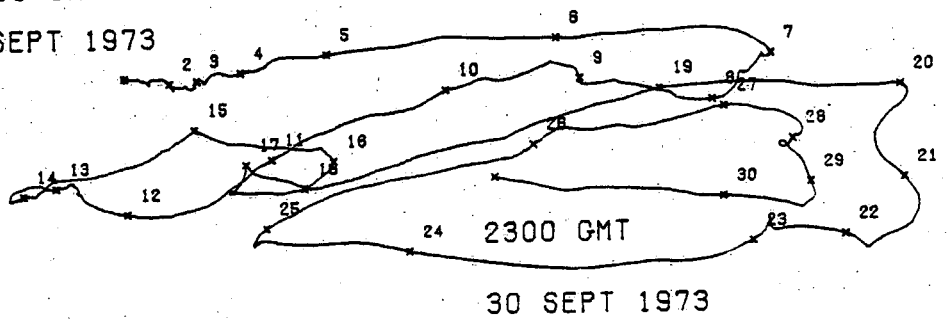

cm/sec.  
(mean scalar speed)

# Current PVD's

Shallow Meters

Sept. 1973

MOORING: 28 DEPTH: 8M

0100 GMT

1 SEPT 1973

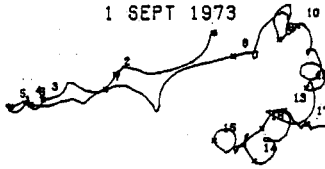

2300 GMT

30 SEPT 1973

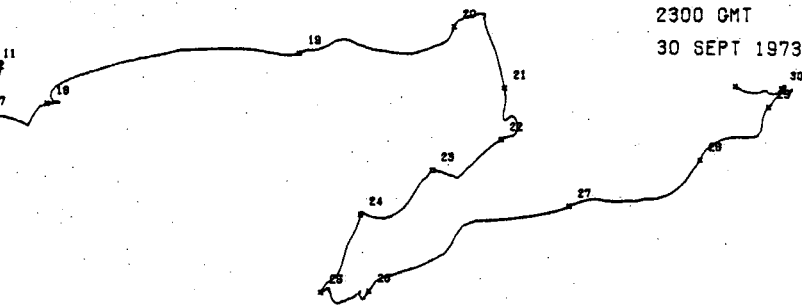

0100 GMT

1 SEPT 1973

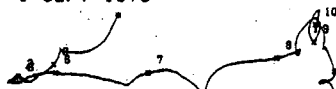

MOORING: 27 DEPTH: 9M

0100 GMT

20 SEPT 1973

0300 GMT

15 SEPT 1973

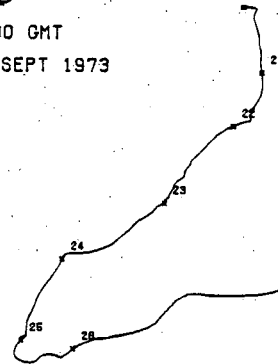

2300 GMT

30 SEPT 1973

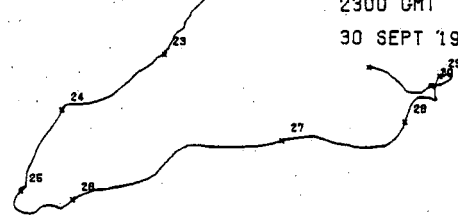

MOORING: 25 DEPTH: 9M

0100 GMT

1 SEPT 1973

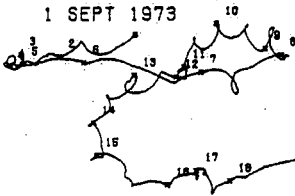

0500 GMT

22 SEPT 1973

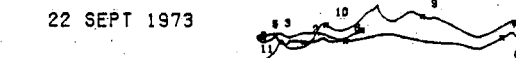

MOORING: 23 DEPTH: 9M

0100 GMT

1 SEPT 1973

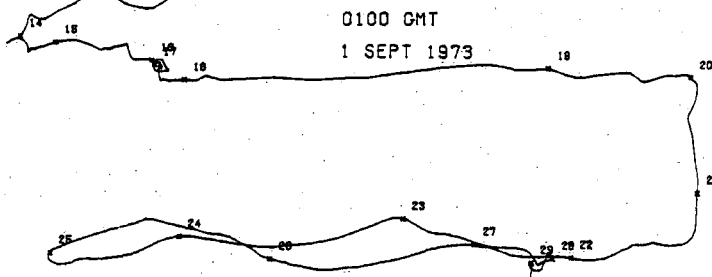

2300 GMT

30 SEPT 1973

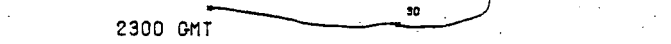

2300 GMT

30 SEPT 1973

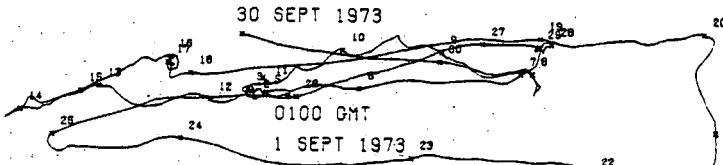

0100 GMT

1 SEPT 1973

MOORING: 22 DEPTH: 9M

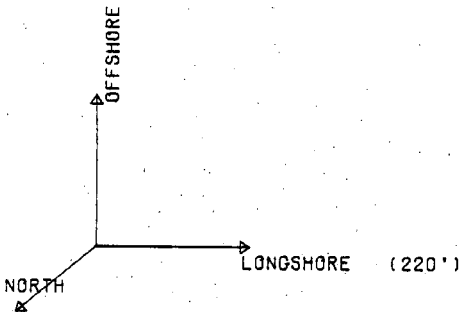
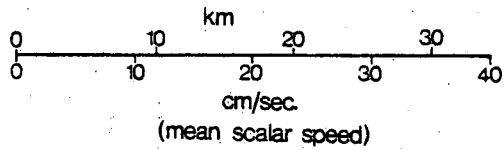
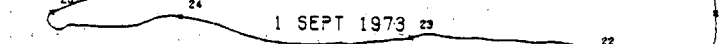

Current PVD's

Shallow Meters

Oct. 1973

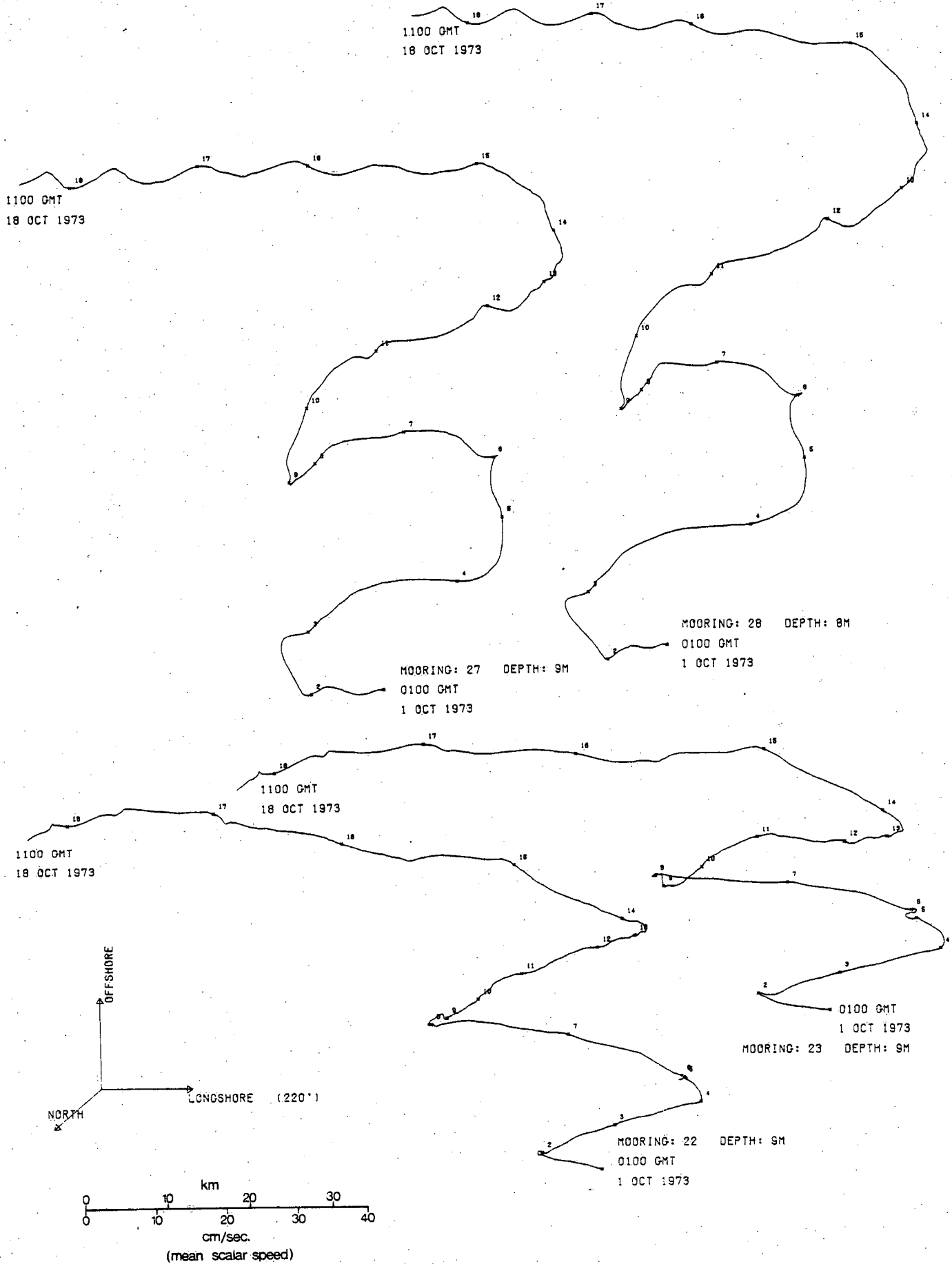

# Current PVD's

Oct. 1973

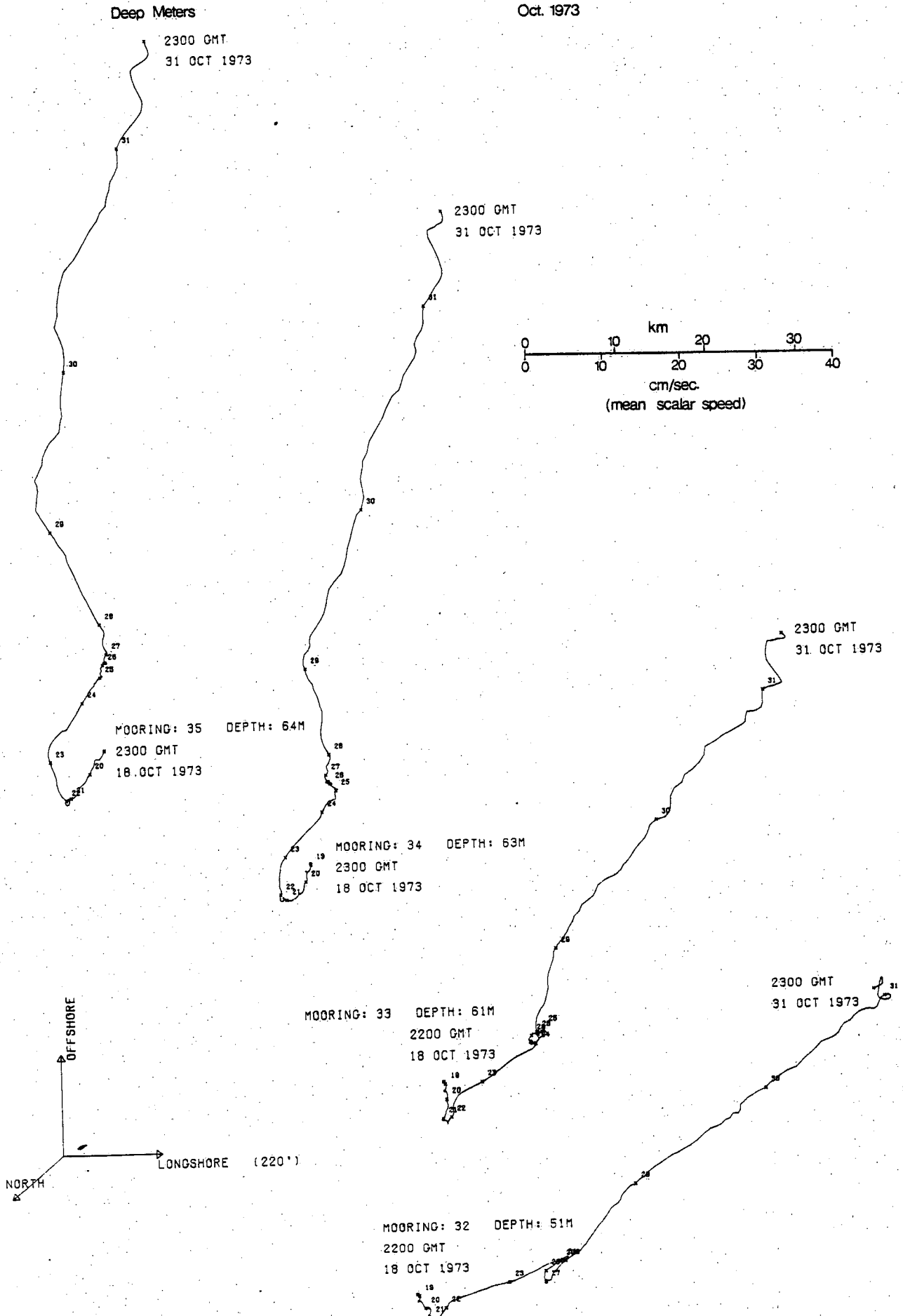

Current PVD's

Oct. 1973

Shallow Meters

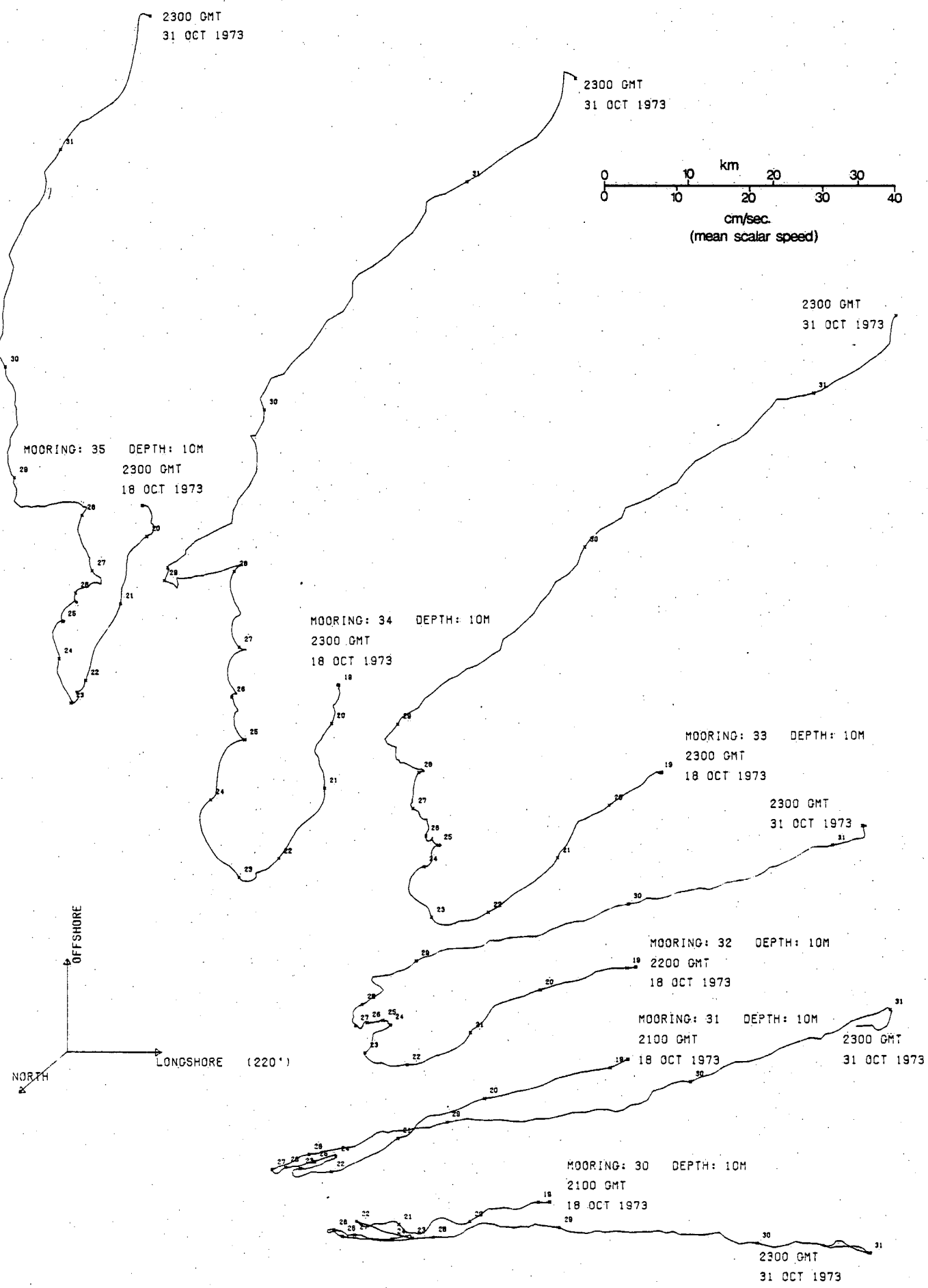

# Current PVD's

Nov. 1973

Deep Meters

MOORING: 35 DEPTH: 64M  
0100 GMT  
1 NOV 1973

MOORING: 34 DEPTH: 63M  
0100 GMT  
1 NOV 1973

MOORING: 33 DEPTH: 61M  
0100 GMT  
1 NOV 1973

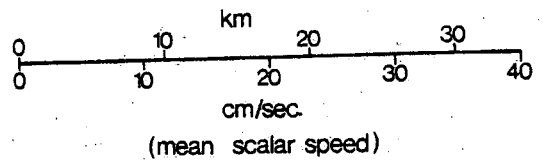
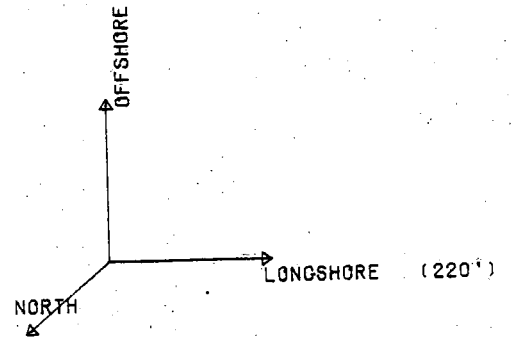

MOORING: 32 DEPTH: 51M  
0100 GMT  
1 NOV 1973

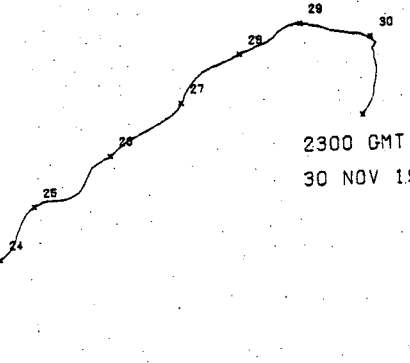
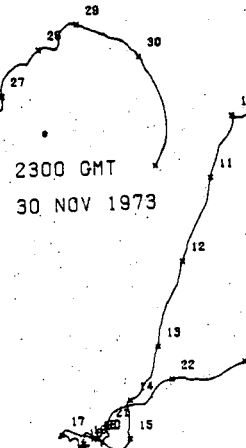
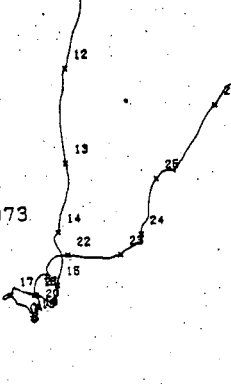
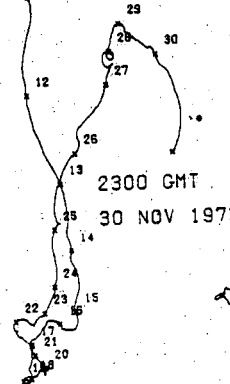
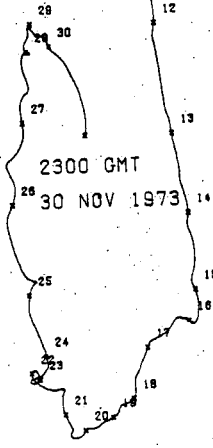



Current PVD's

Skilow Meters

Nov 1973

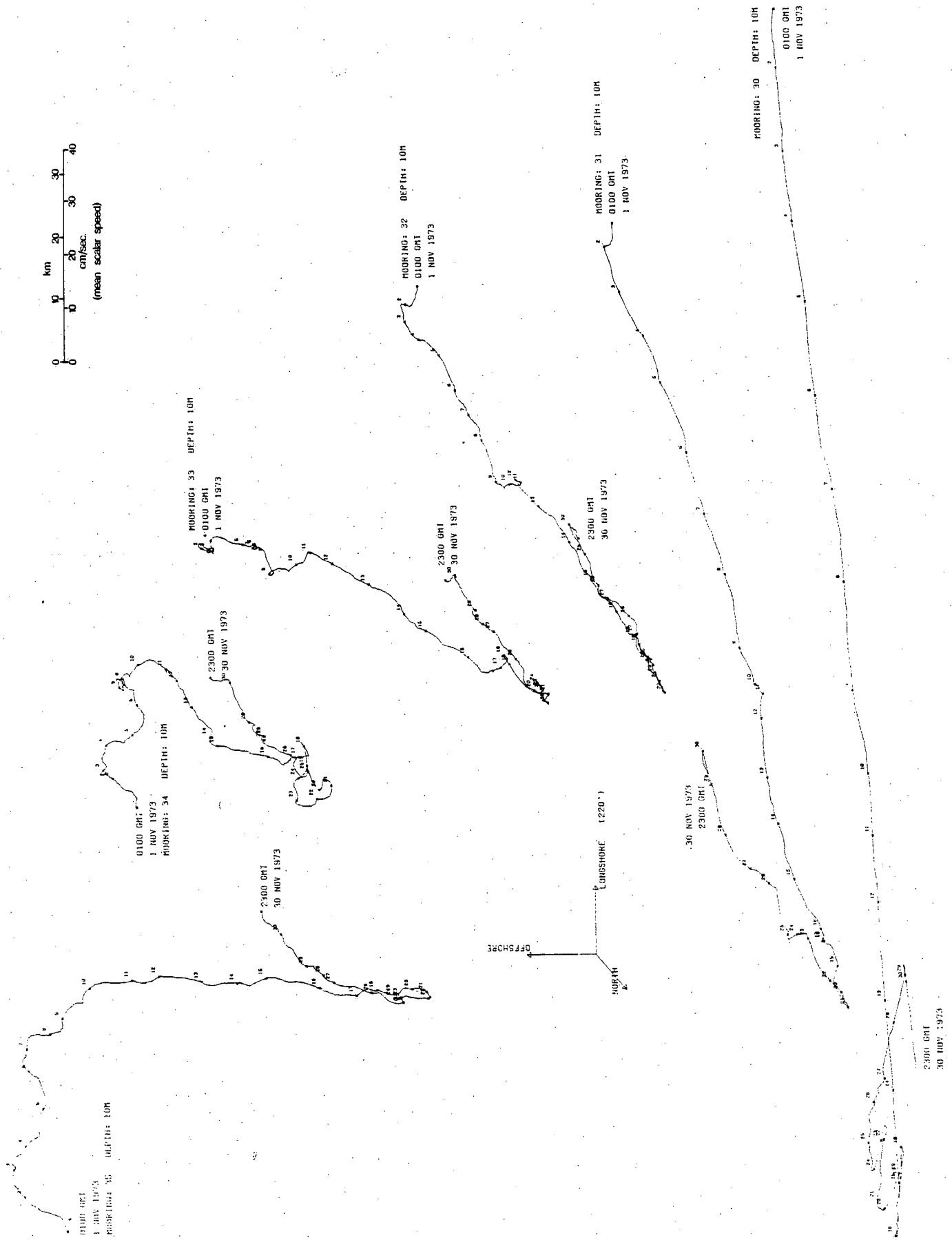

# Current PVD's

Deep Meters

Dec. 1973

MOORING: 35 DEPTH: 64M  
1100 GMT  
1 DEC 1973

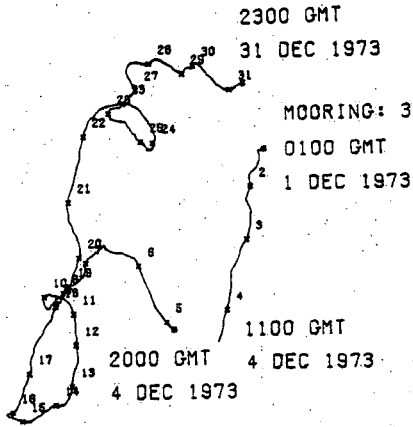
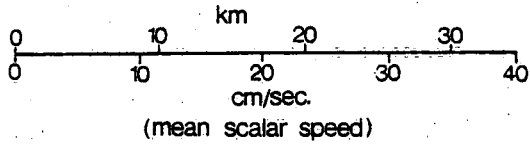

0100 GMT  
10 DEC 1973

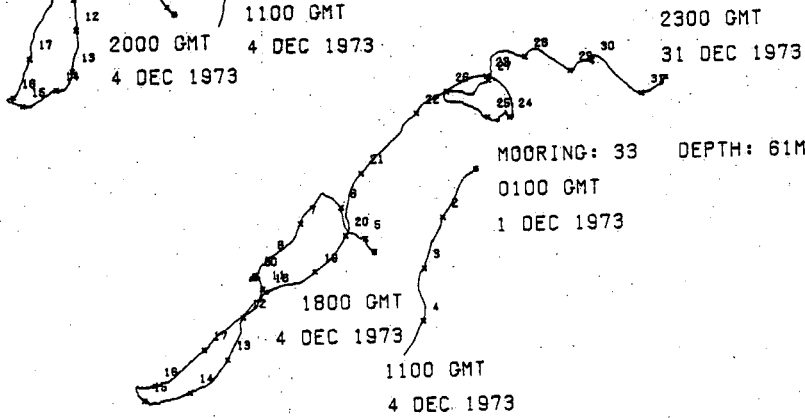

MOORING: 32 DEPTH: 51M  
0100 GMT  
1 DEC 1973

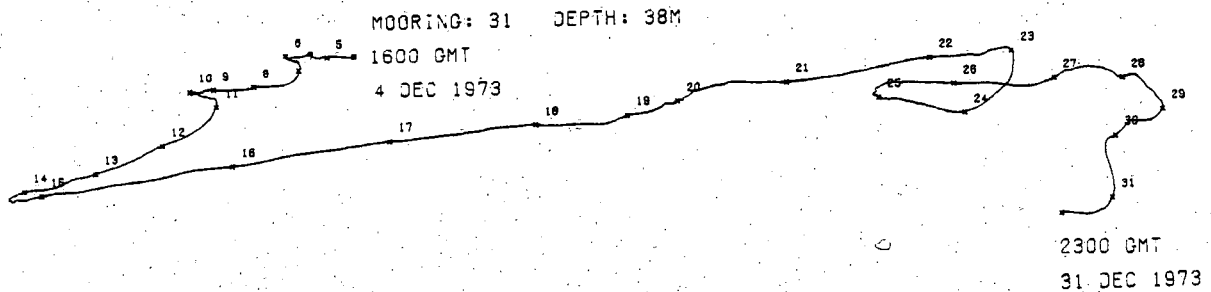
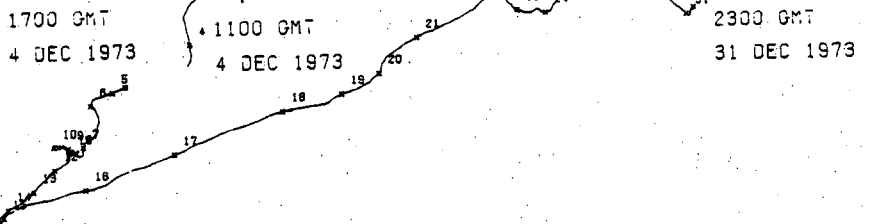
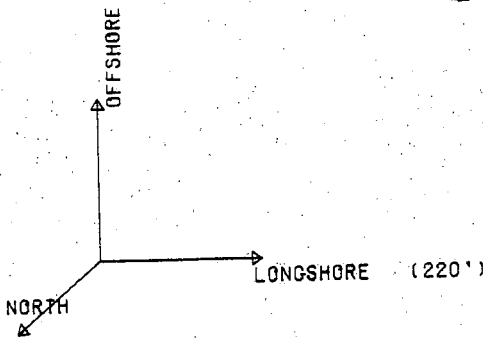

# Current PVDs

Shallow Meters

Dec. 1973

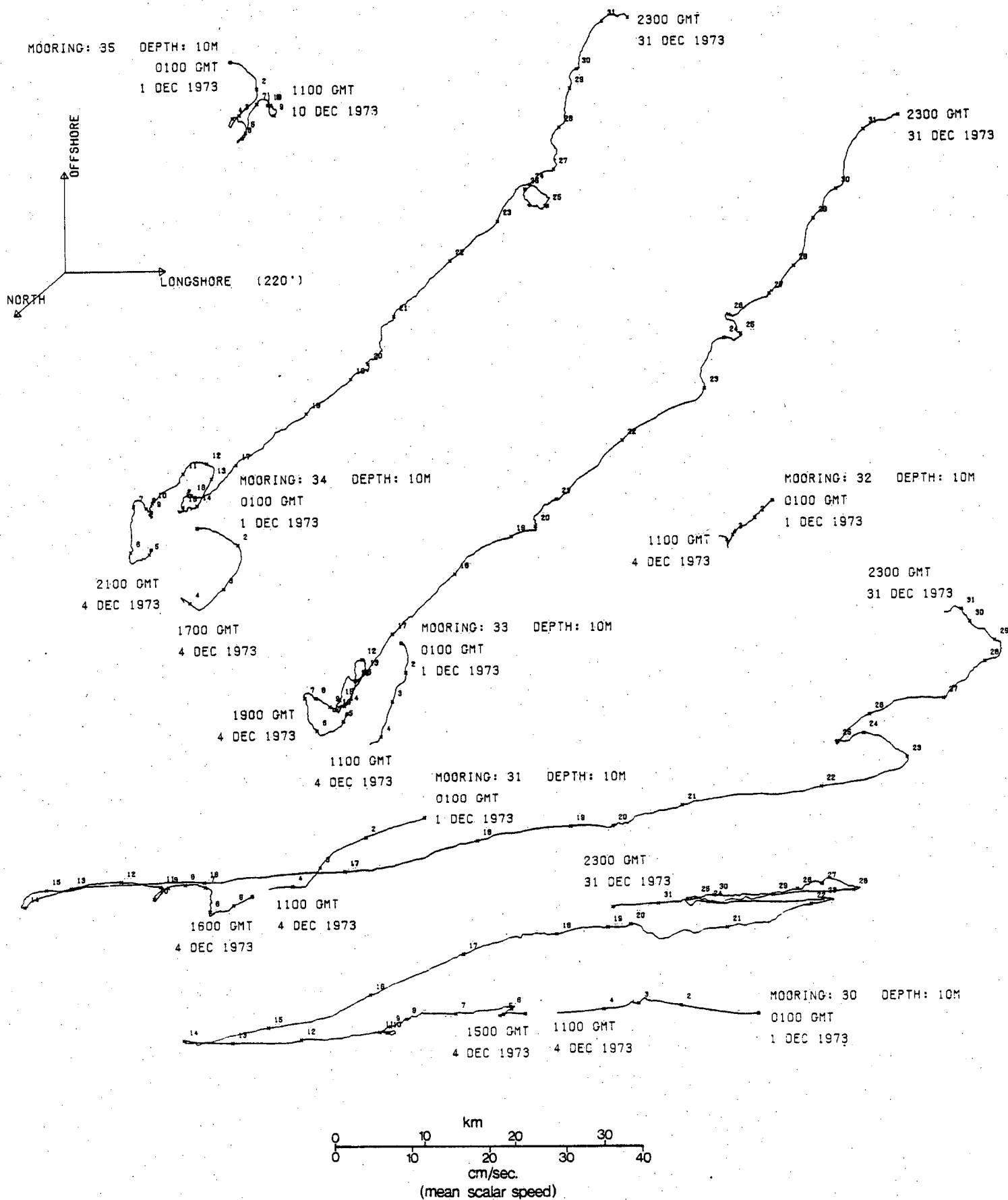

# Current PVD's

Deep Meters

Jan. 1974

MOORING: 34 DEPTH: 63M  
0100 GMT  
1 JAN 1974

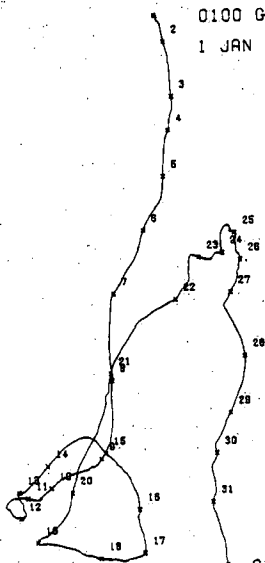

MOORING: 33 DEPTH: 61M  
0100 GMT  
1 JAN 1974

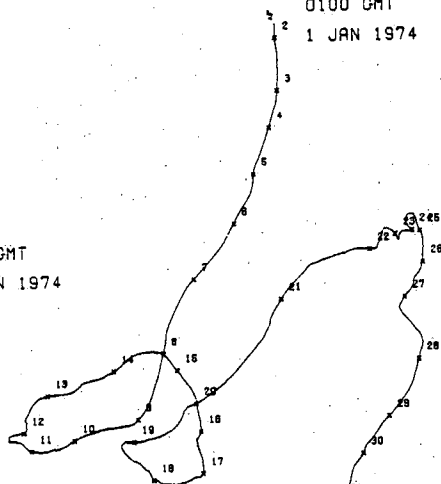

2300 GMT  
31 JAN 1974

2300 GMT  
31 JAN 1974

MOORING: 32 DEPTH: 51M  
0100 GMT  
1 JAN 1974

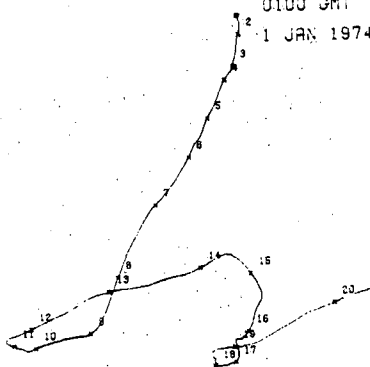

2300 GMT  
31 JAN 1974

MOORING: 31 DEPTH: 38M  
0100 GMT  
1 JAN 1974

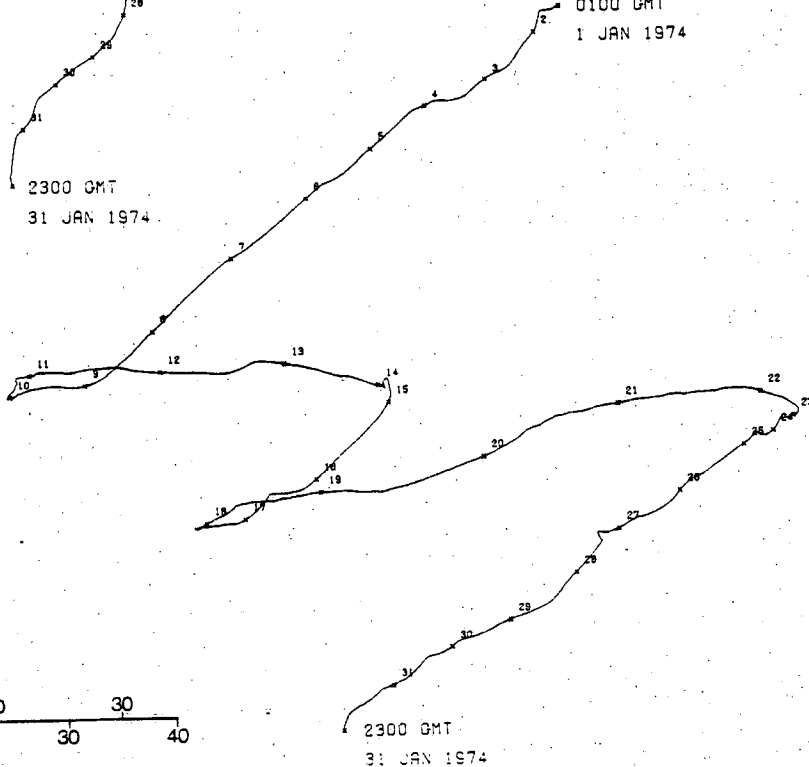

2300 GMT  
31 JAN 1974

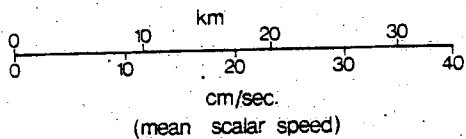
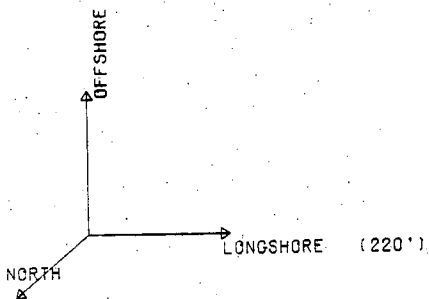

# Current PVD's

Shallow Meters

Jan. 1974

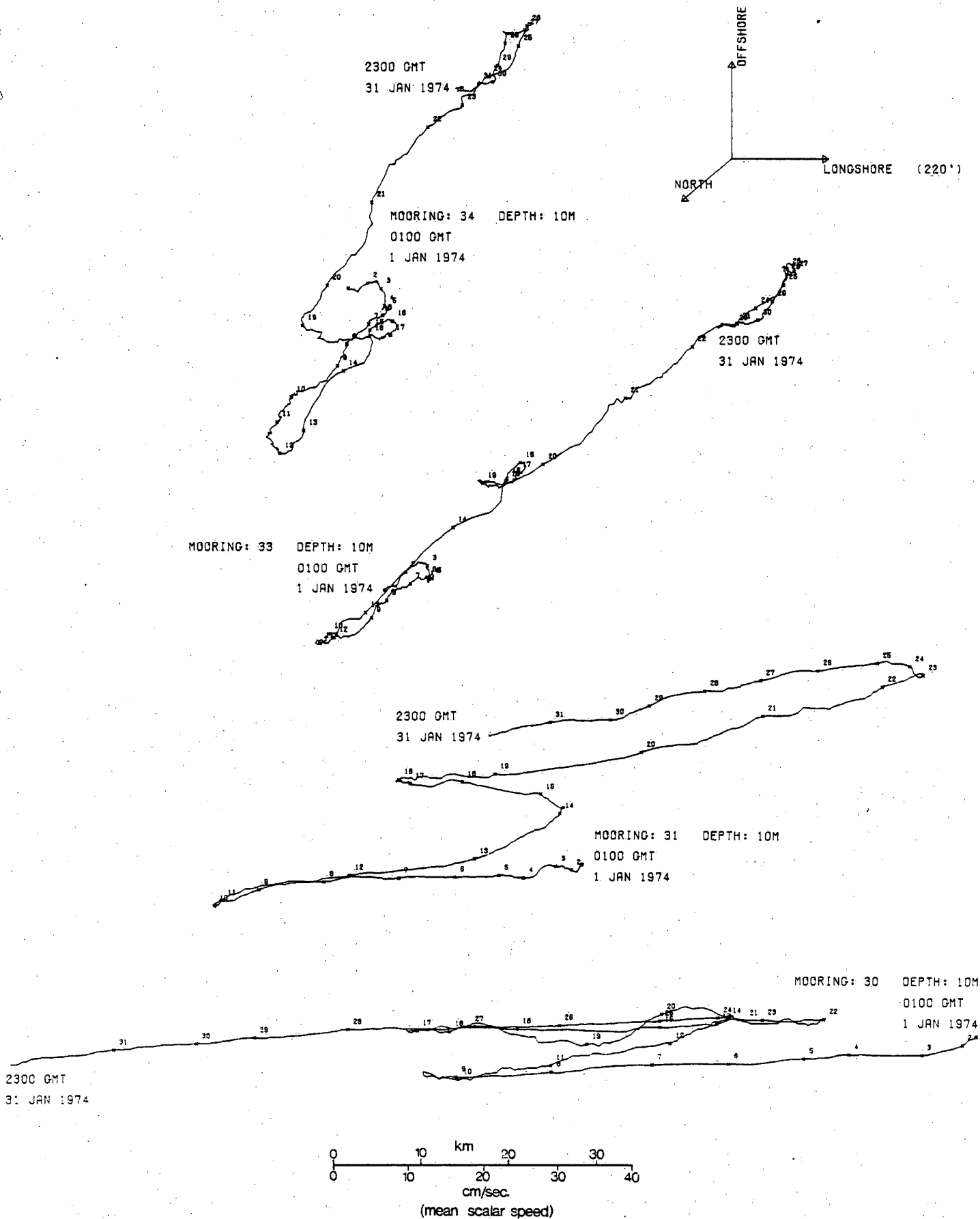

# Current PVD's

Feb. 1974

Deep Meters

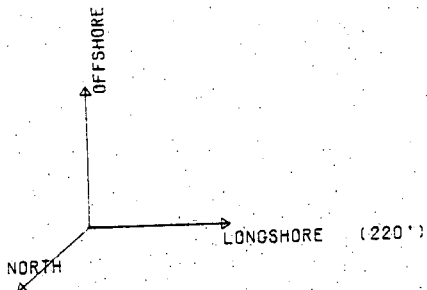
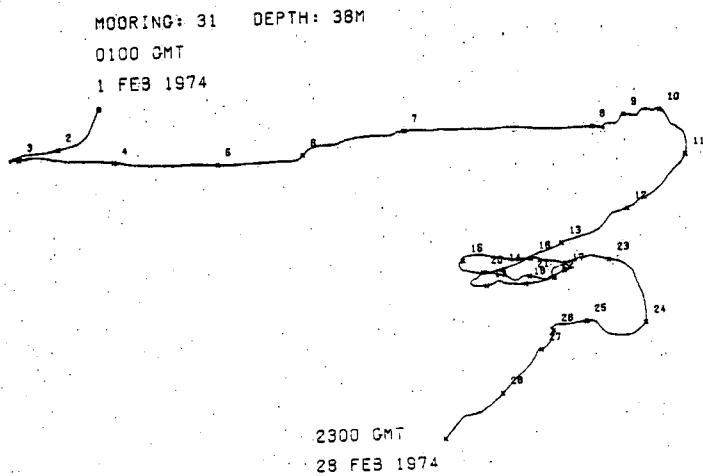
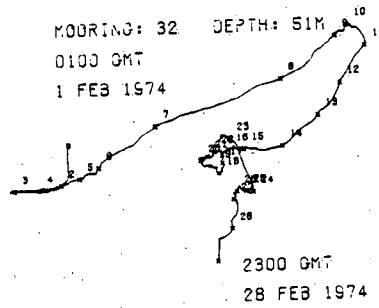
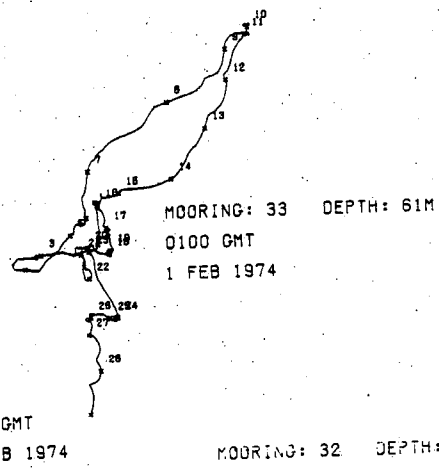
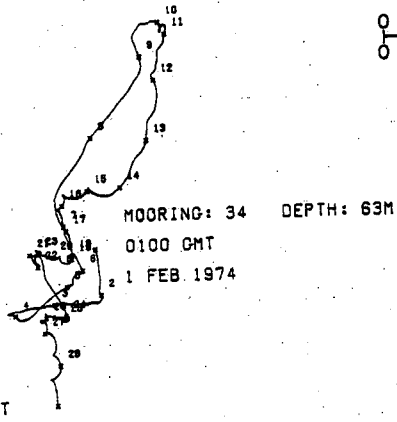
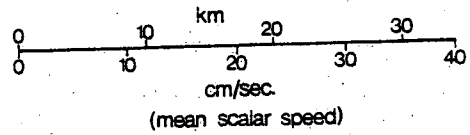

# Current PVD's

Shallow Meters

Feb. 1974

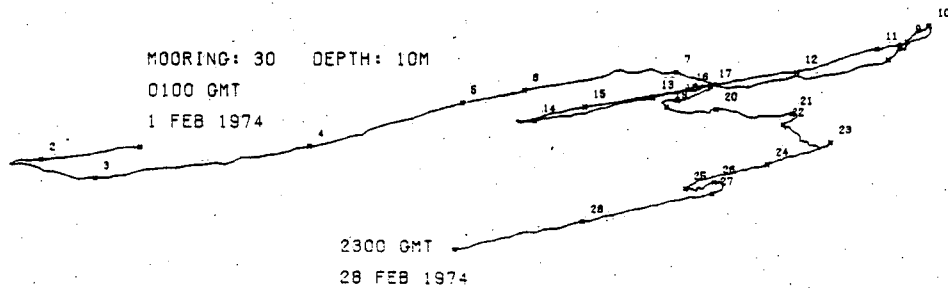
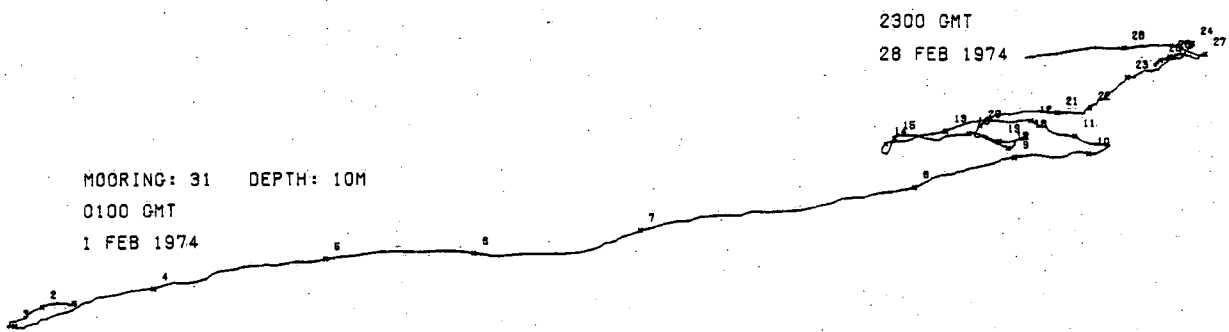
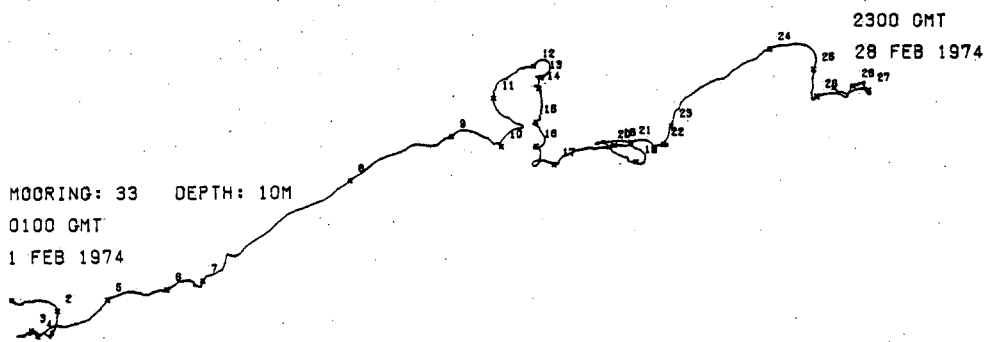
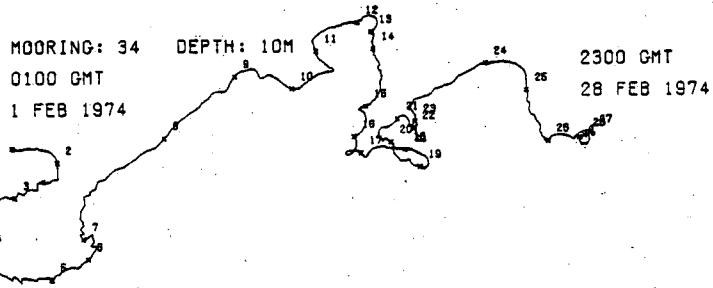
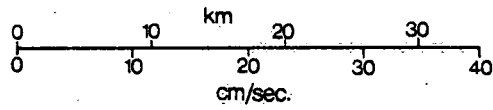
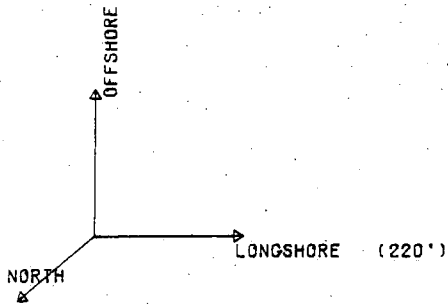

# Current PVD's

Deep Meters

March 1974

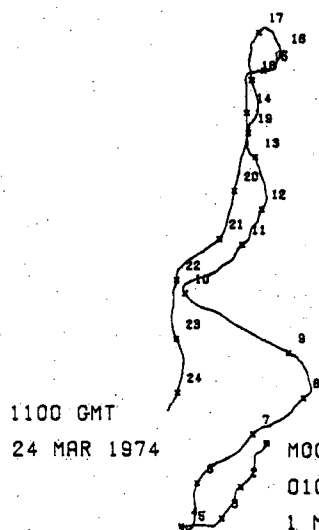
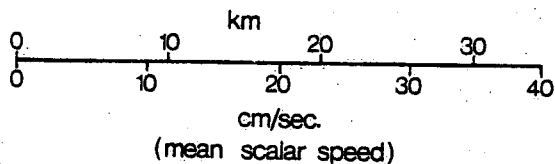

1100 GMT  
24 MAR 1974

MOORING: 34 DEPTH: 63M  
0100 GMT  
1 MAR 1974

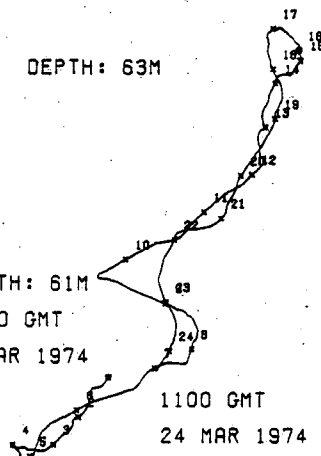

MOORING: 33 DEPTH: 61M  
0100 GMT  
1 MAR 1974

1100 GMT  
24 MAR 1974

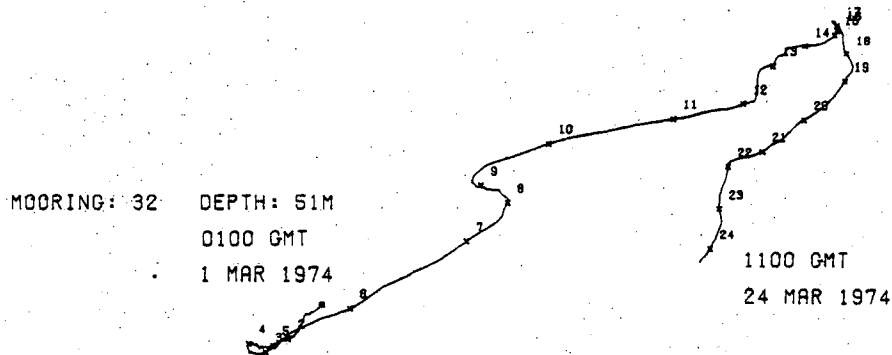
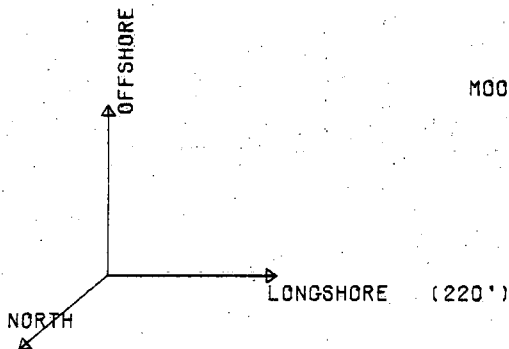

MOORING: 32 DEPTH: 51M  
0100 GMT  
1 MAR 1974

1100 GMT  
24 MAR 1974

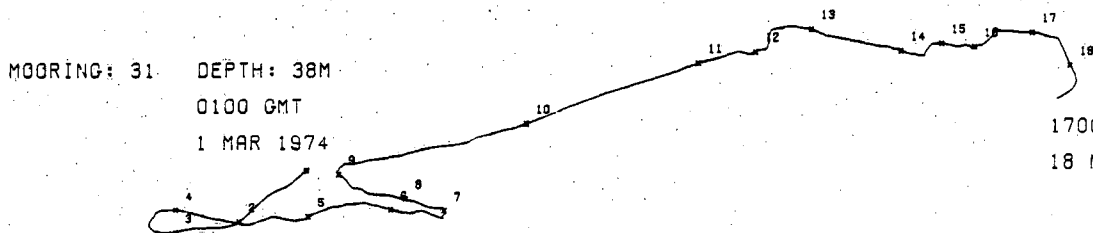

MOORING: 31 DEPTH: 38M  
0100 GMT  
1 MAR 1974

1700 GMT  
18 MAR 1974



APPENDIX E: CURRENT COMPONENT SUMMARY

FILTERED CURRENT COMPONENTS (0.0 to 0.2 cph)

DATE: November 1973

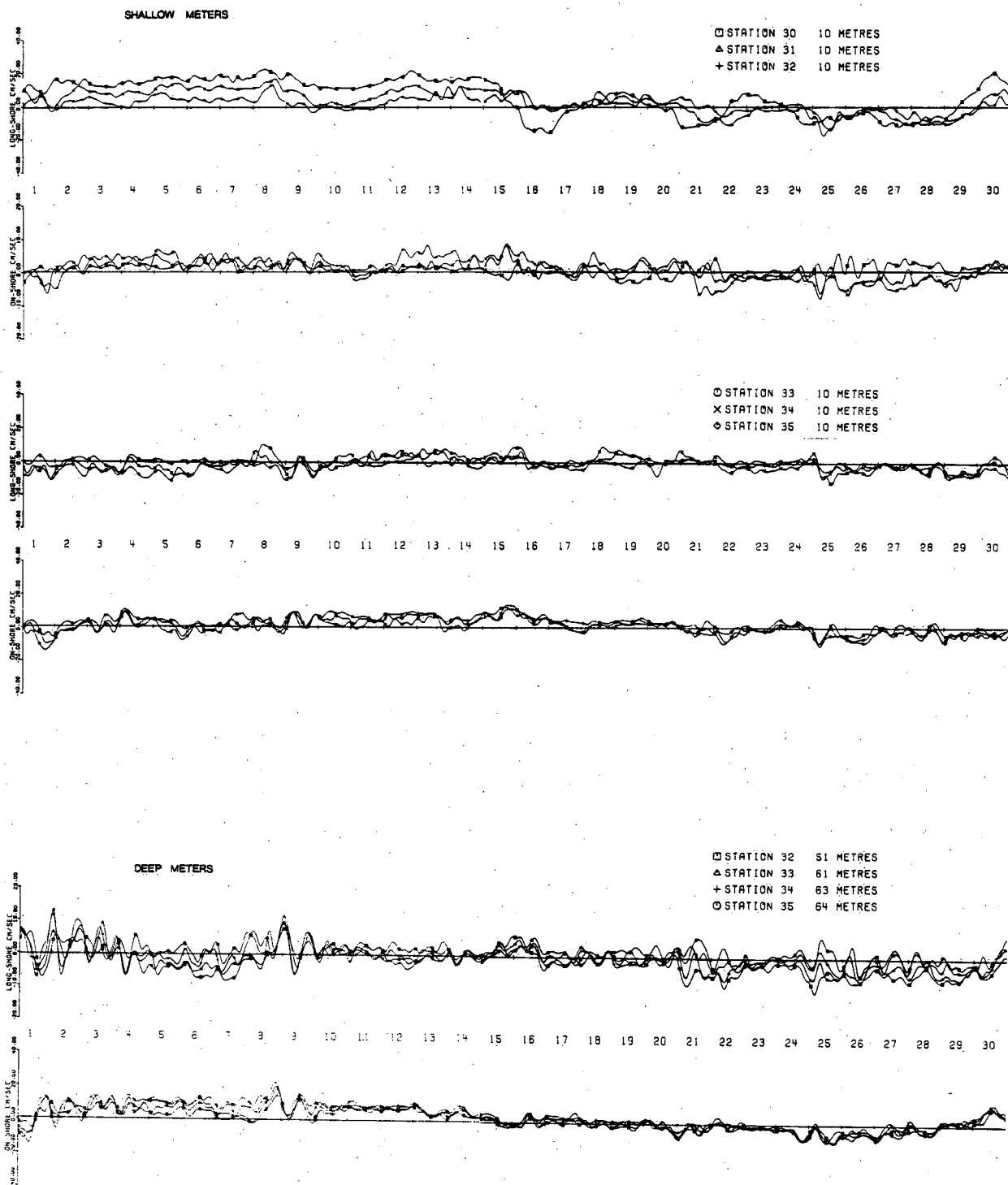

# FILTERED CURRENT COMPONENTS (0.0 to 0.2 cph)

DATE : October 1973

## SHALLOW METERS

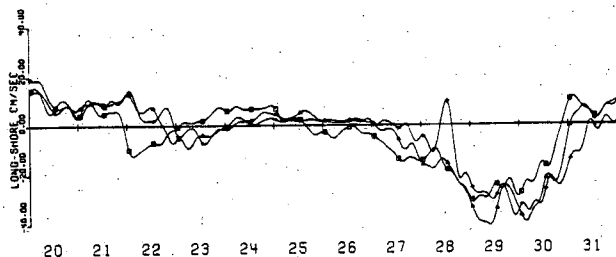

□ STATION 30 10 METRES  
 ▲ STATION 31 10 METRES  
 + STATION 32 10 METRES

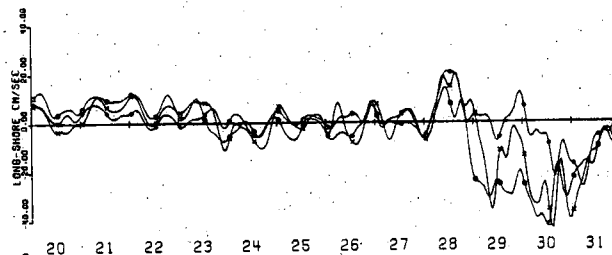
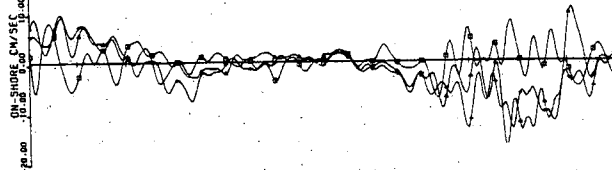

○ STATION 33 10 METRES  
 × STATION 34 10 METRES  
 ◇ STATION 35 10 METRES

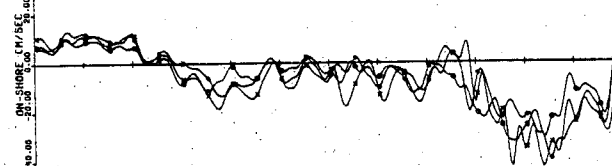

## DEEP METERS

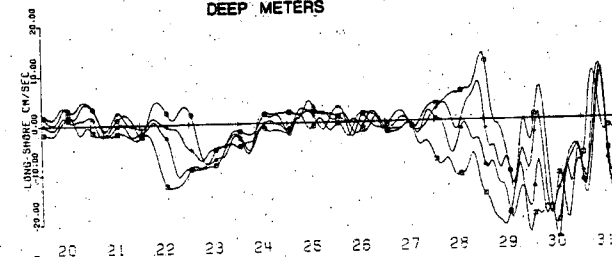

□ STATION 32 51 METRES  
 ▲ STATION 33 61 METRES  
 + STATION 34 63 METRES  
 ○ STATION 35 64 METRES

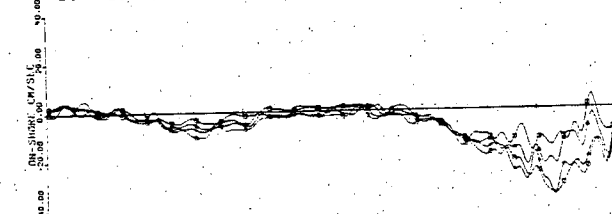

# FILTERED CURRENT COMPONENTS (0.0 to 0.2 cph)

DATE: January 1974

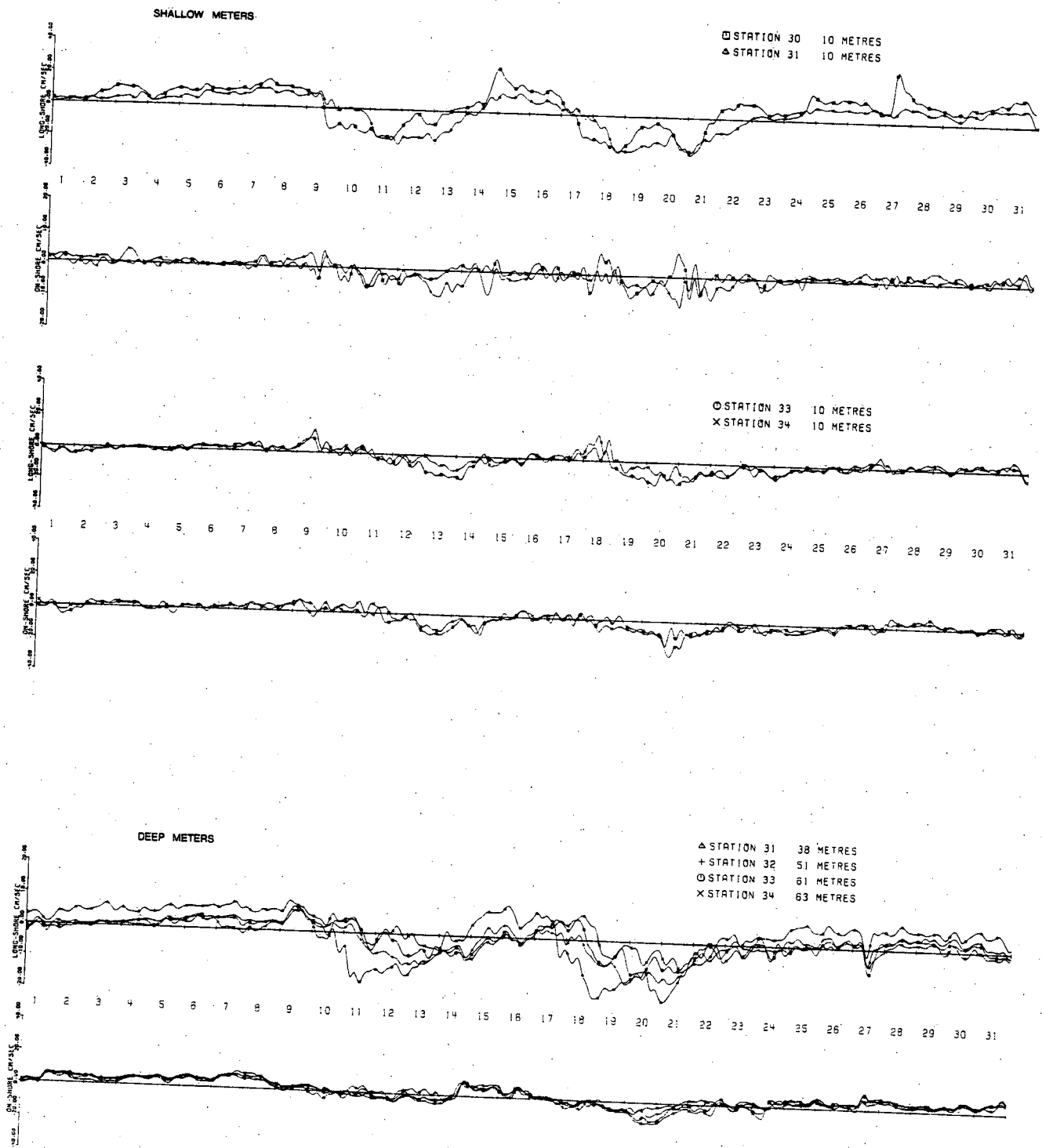

FILTERED CURRENT COMPONENTS (0.0 to 0.2 cph)

DATE: December 1973

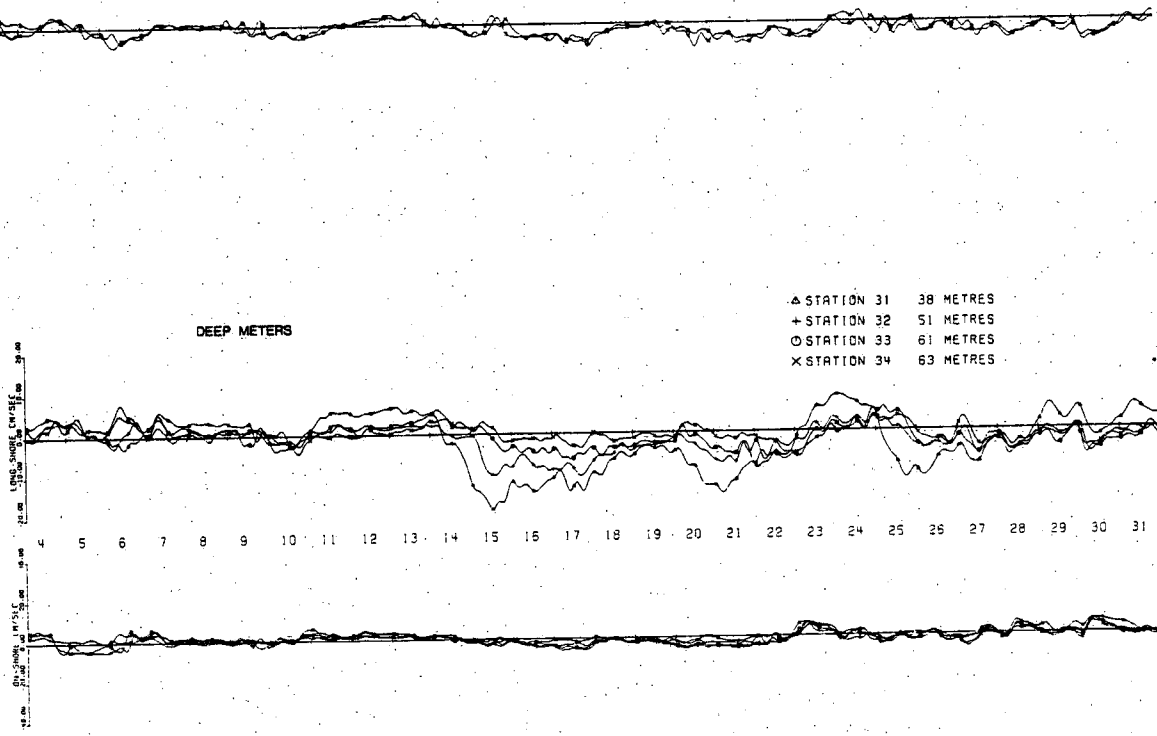
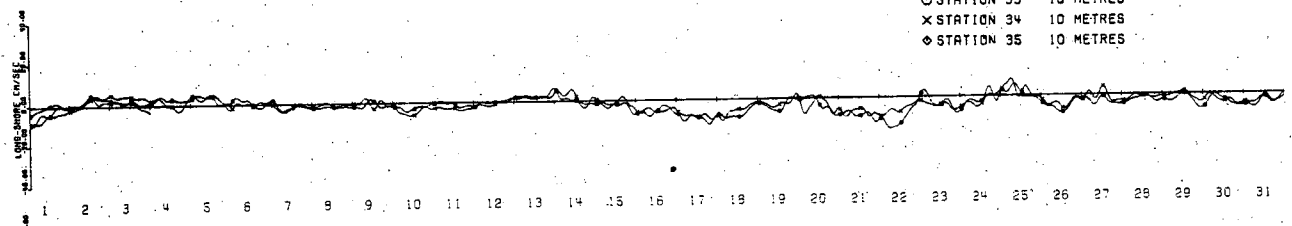
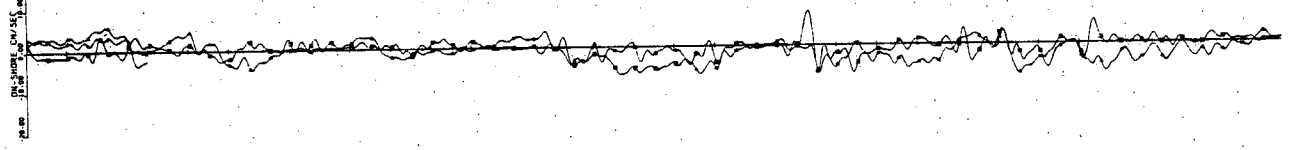
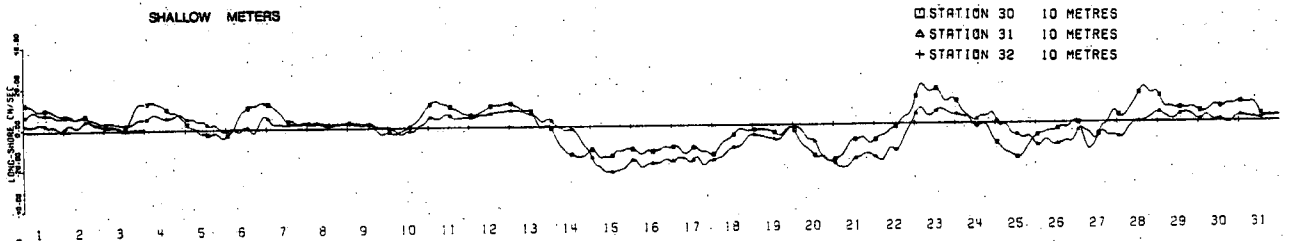

# FILTERED CURRENT COMPONENTS (0.0 to 0.2 cph)

DATE : March 1974

## SHALLOW METERS

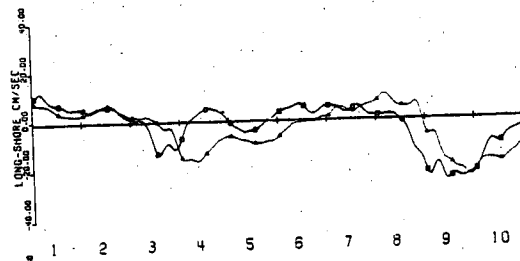

□ STATION 30 10 METRES  
 ▲ STATION 31 10 METRES

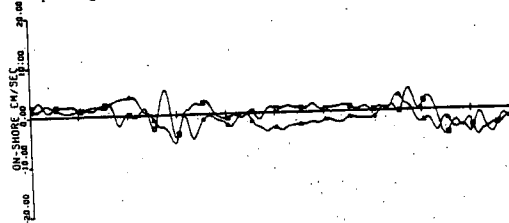

○ STATION 33 10 METRES  
 × STATION 34 10 METRES

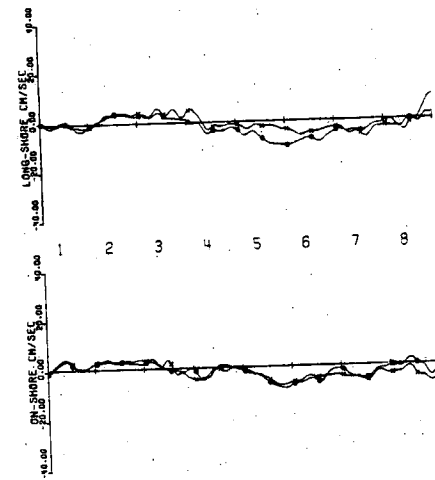

## DEEP METERS

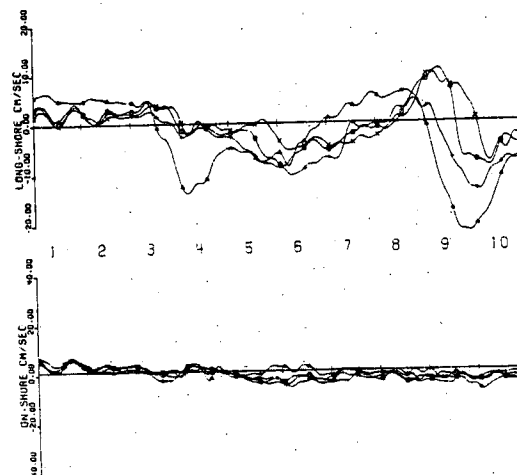

▲ STATION 31 38 METRES  
 + STATION 32 51 METRES  
 ○ STATION 33 61 METRES  
 × STATION 34 63 METRES

# FILTERED CURRENT COMPONENTS (0.0 to 0.2 cph)

DATE: February 1974

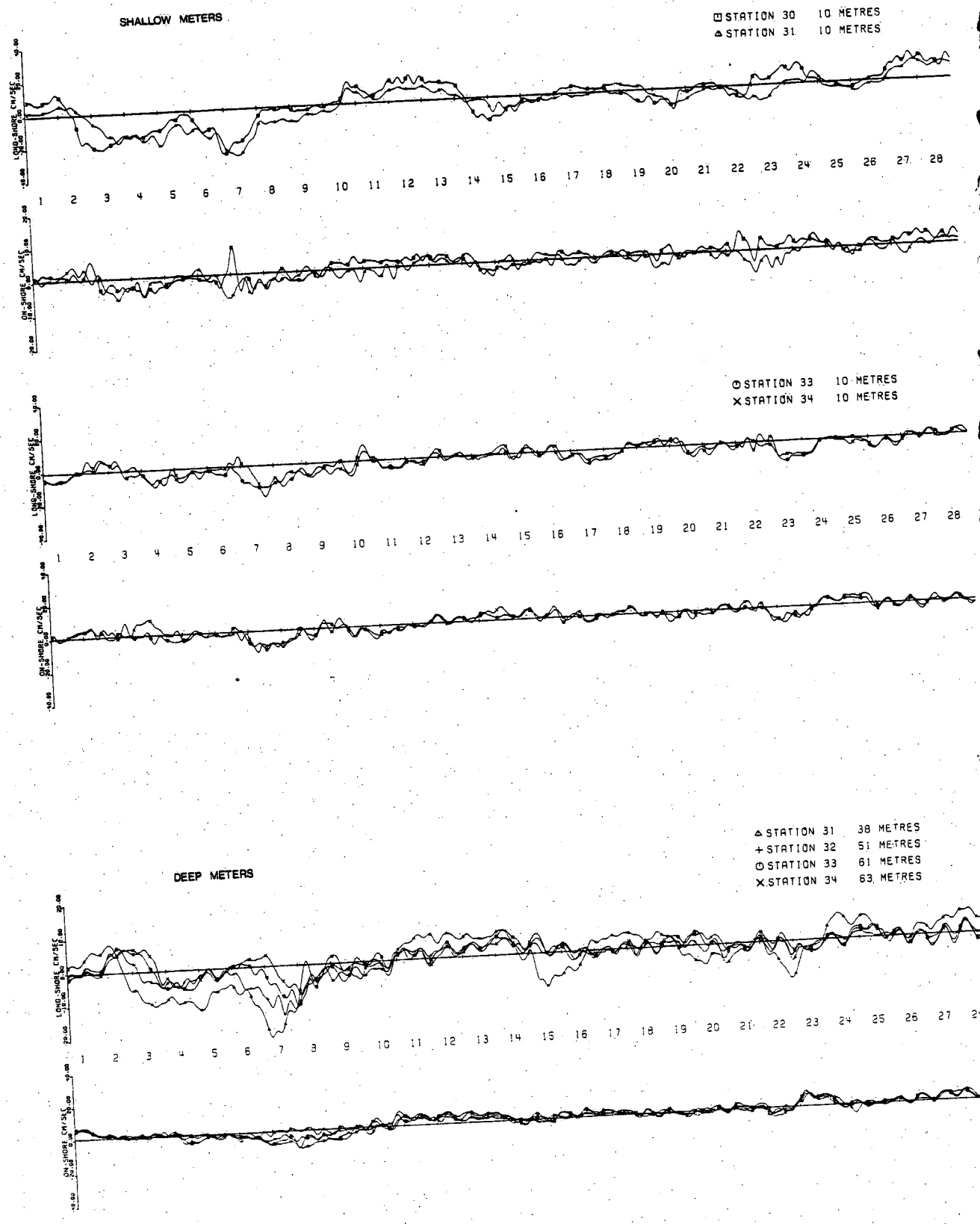

APPENDIX F: INSTRUMENTATION SPECIFICATION AND  
MOORING CONFIGURATION



Time Constant: Approximately 30 seconds without radiation shielding

Exposure: Mounted in a naturally aspirated Thaller type radiation shield<sup>2</sup>

WATER TEMPERATURE

Sensor: YSI No. 44030 Precision Thermistor installed in a 2.5 cm DIA x 15 cm plexiglass housing

Range: -2 to +35°C

Accuracy: 0.1°C with individual calibration

Time Constant: Approximately 5 minutes

---

<sup>2</sup>Thaller, M., 1970. Practical considerations in instrument design. In *Meteorological Monographs*, 11(33):211-236, American Meteorological Society, Boston, Mass.

INSTRUMENTATION SPECIFICATION: METEOROLOGICAL SYSTEM<sup>1</sup> (CCIW)

Recording System: Plessey Electronics, Hymet Model MM-1

Recording Medium: 6.35 mm (1/4 inch) magnetic tape reel to reel, 183 metre  
at 4.3 mm/sec

Parameters Recorded: Windspeed, wind direction, air temperature, and  
water surface temperature

Word Size: 10 bit

Storage Capacity: 55,000 words

Sampling Rate: 10 minute

Operational Temperature Range: -10°C to 40°C

WIND SPEED SENSOR

Anemometer: 3 cup (Beckman and Whitley; Model 170-41) geared to a single  
continuous turn potentiometer through a 11106.46:1 speed  
reducer

Sampling Method: 10 minute average

Accuracy:  $\pm 2\%$  above 200 cm sec<sup>-1</sup>

Static Torque: 0.36 gram-cm max

WIND DIRECTION

Sensor: Single flat-plate vane coupled to an oil-damped magnetic compass

Sampling Method: Instantaneous position read on command every 10 minutes  
by solenoid clamping of the compass

Accuracy:  $\pm 5$  degrees

AIR TEMPERATURE

Sensor: YSI No. 44005 Precision Thermistor in a copper heat sink

Range: -10 to +40°C

Accuracy:  $\pm 0.1^\circ\text{C}$  with individual calibration

---

<sup>1</sup> Elder, F.C. and Brady, B.P., 1972. A meteorological buoy system for  
Great Lakes studies. Environment Canada, IWD Technical Bulletin  
No. 71.

Word Size: 10 bits

Tape Capacity: 55,200 words

Speed Sensor: Propeller with magnetic coupling and reduction gearing driving a potentiometer.

Speed Range: 5.0 to 250 cm/sec

Speed Threshold: Rated at 3 cm/sec but depends on mechanical condition of propeller bearings.

Speed Accuracy: 3% or 3 cm/sec whichever is greater

Direction Sensor: Instantaneous position read on command every scan by solenoid clamping of the compass.

Direction Resolution: 2 degrees compass

Time: Calculated by start time and time per record; no independent clock.

INSTRUMENT SPECIFICATIONS: CURRENT METERS

1. Geodyne Model 920 Current Meter (CCIW)

Recording Medium: 6.35 mm (1/4 inch) endless loop magnetic tape,  
120 metres (390 ft.), 2 track, 512 BPI at 6.4  
bits/second

Format: Serial digital

Word Size: 16 bit, 12 used for reference, time and temperature,  
14 bits used for identity and compass-vane words

Tape Capacity: 180,000 words

Speed Sensor: Savonius rotor with magnetic coupling, 16 counts per  
revolution measured over 4.375 secs per reading

Speed Range: 2 cm/sec to 360 cm/sec

Speed Threshold: Rated at 2 cm/sec but depends on bearing condition  
and rotor balance

Speed Accuracy:  $\pm 2.5$  cm/sec below 50 cm/sec,  $\pm 5$  cm/sec above  
50 cm/sec

Direction Sensor: Compass-vane system of two seven bit optical code  
discs, measured simultaneously, and recorded as  
14 bits.

Direction Accuracy:  $\pm 10$  degrees compass

Time: Linear continuous rotation potentiometer driven at 1 revolution-  
per day to control a transducer controlled oscillator (TCO).  
The frequency of this TCO is counted for 1.875 seconds to give  
a timeword.

Time Accuracy: Maximum cumulative error of 10 sec/day based on the  
system clock accuracy.

Temperature Sensor: Resistance of a thermistor is used to control a  
TCO in a manner similar to the timeword.

Temperature Accuracy:  $\pm 0.1^\circ\text{C}$

Temperature Range:  $-2^\circ\text{C}$  to  $+35^\circ\text{C}$

2. Plessey Model M021 Current Meter (CCIW)

Recording Medium: 6.35 mm (1/4 inch) reel to reel magnetic tape.

Format: Serial digital

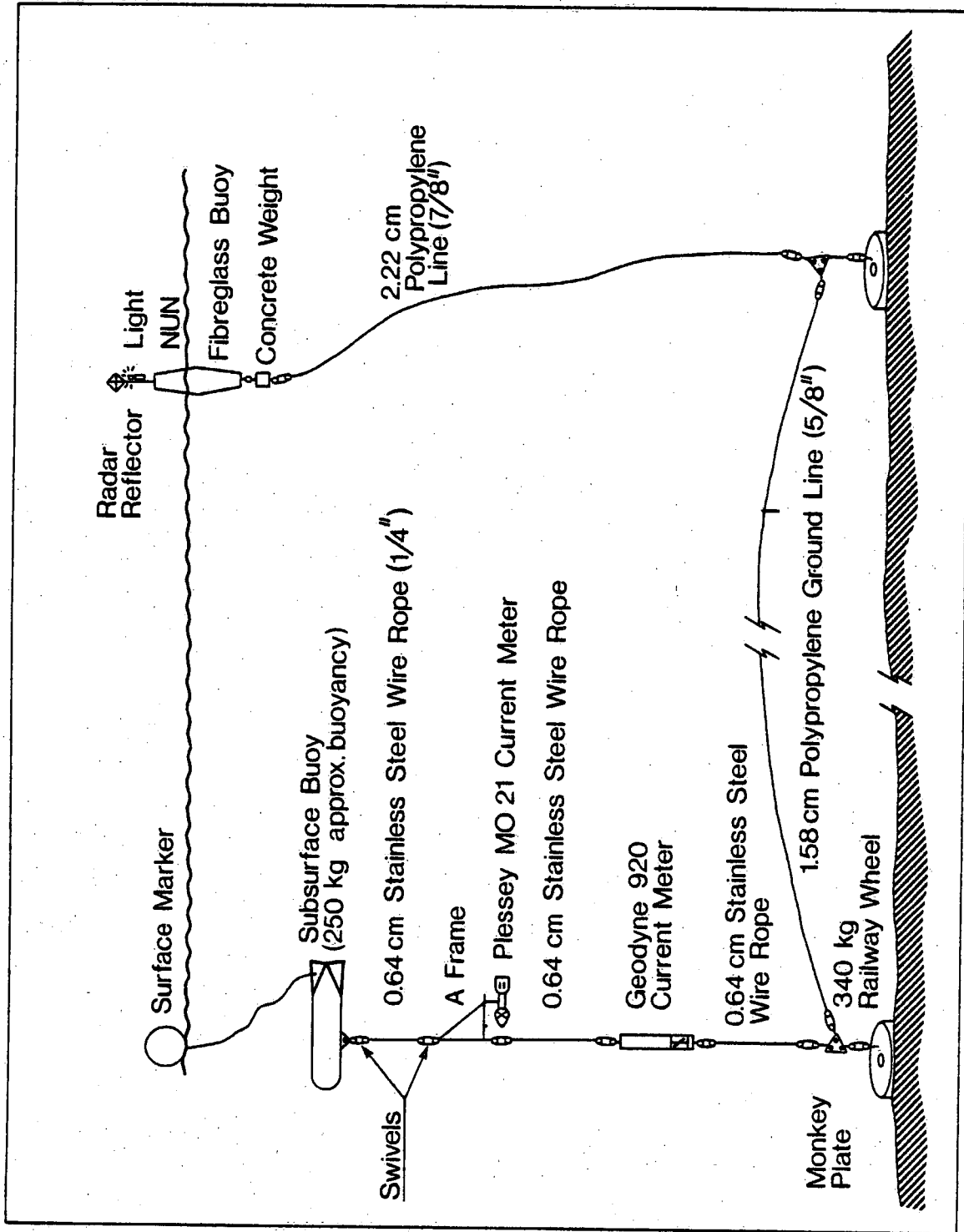

TYPICAL CURRENT MOORING - C.C.I.W

Figure F2

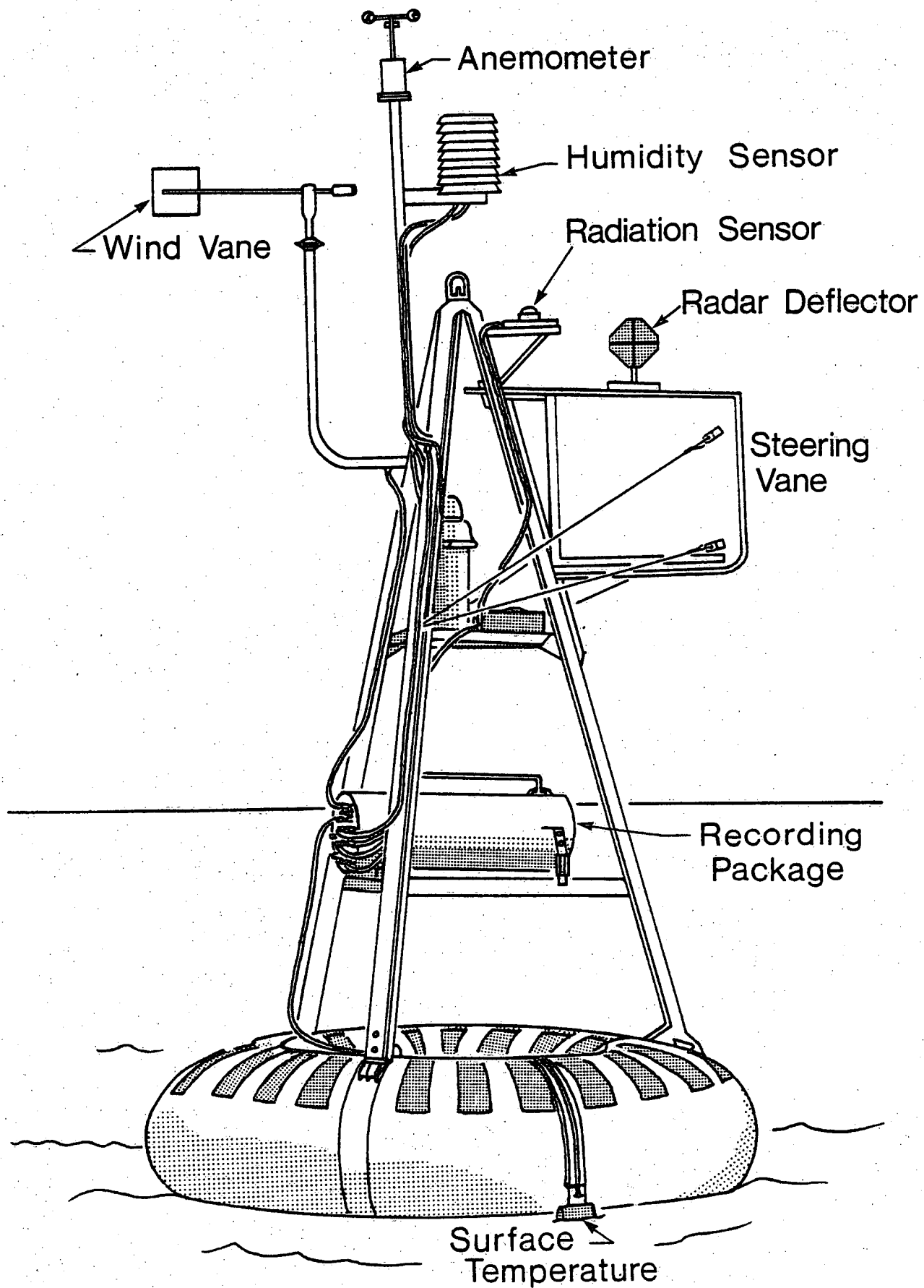

TYPICAL CCIW METEOROLOGICAL BUOY

Figure F1

# PLESSEY CURRENT METER TYPE M021

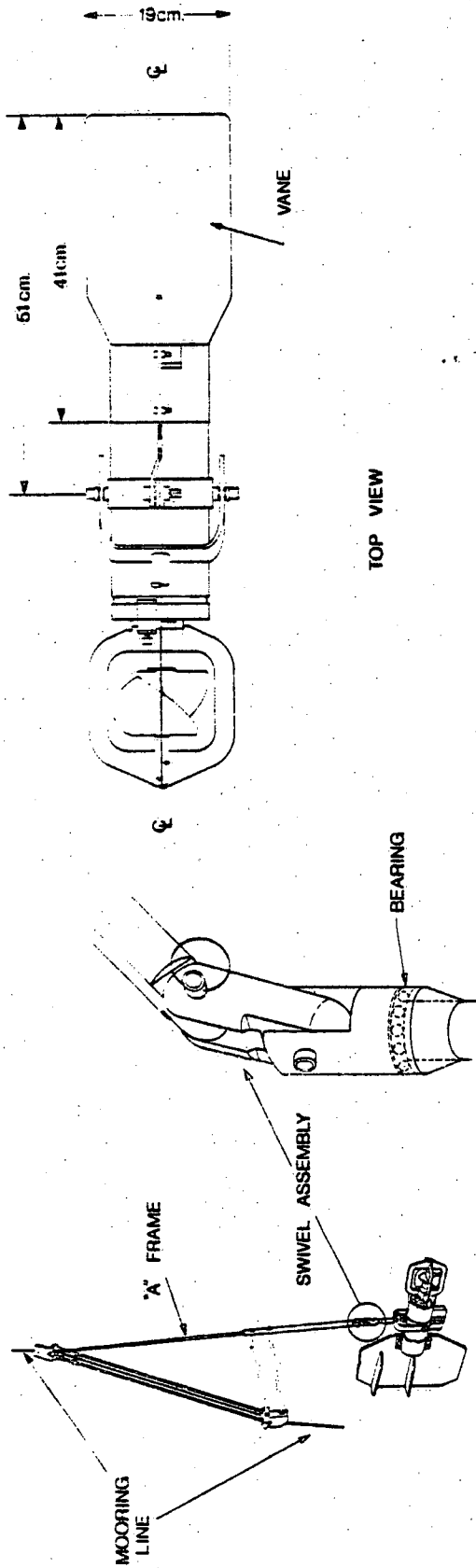

TOP VIEW

METER ATTACHED BY 'A' FRAME TO MOORING LINE.

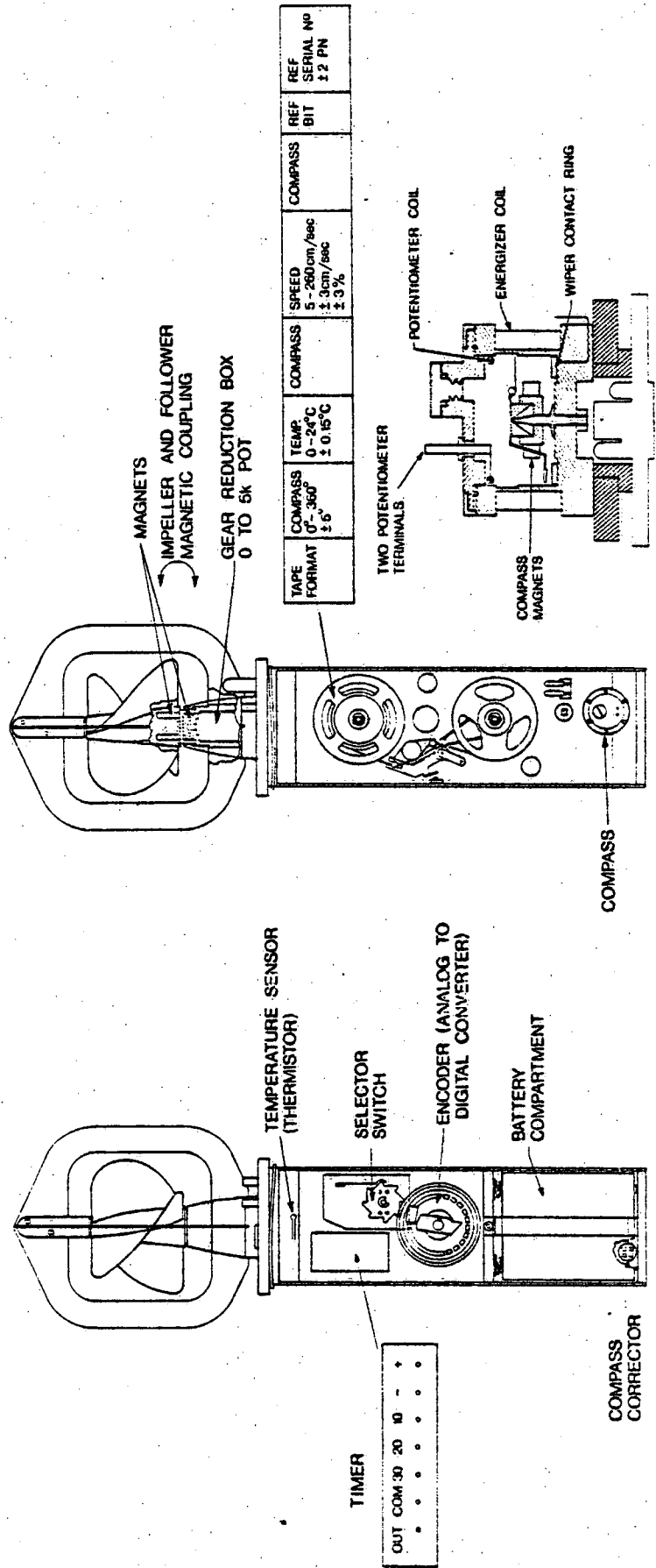
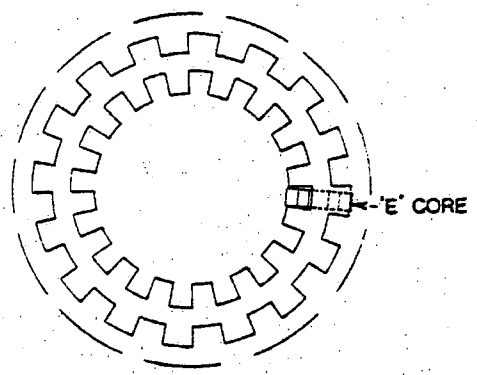
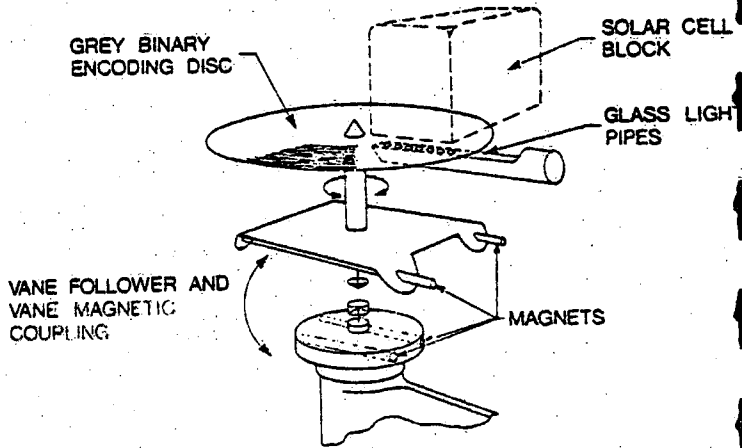
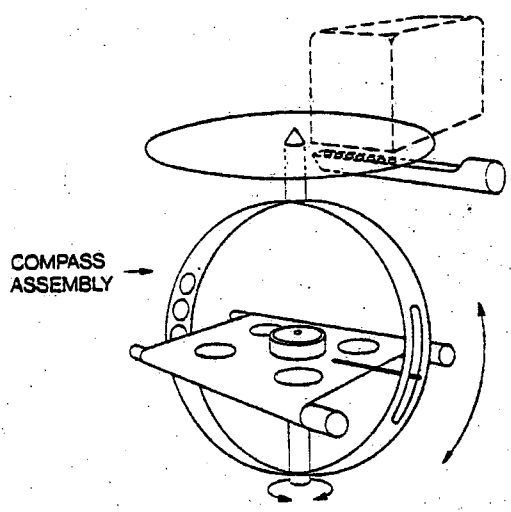
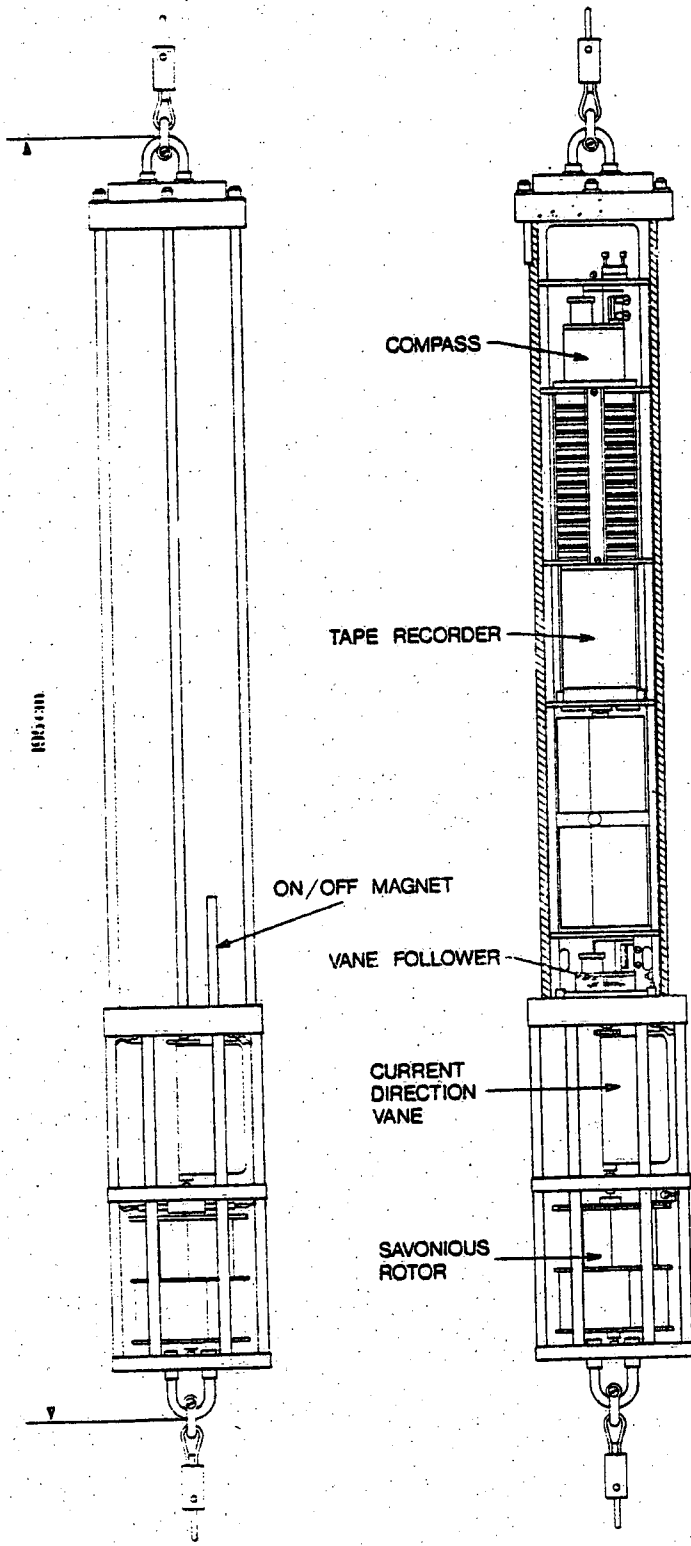

Figure F4



TAPE FORMAT	16 BIT WORD 1 & 2 BIT EMPTY	REF 4000 ± 1	TEMP -2 TO 35°C ± 0.1°C	TIME 1+ ORDINAL OF INTERVAL	IDENT. SER. NO.	SPEED 2 TO 360 cm/s ± 0.5 cm/s	DIRECTION COMPASS + VANE 360° ± 6°	REPEAT TO PERIOD LIMIT (20, 40, 80, 160 SECS.)
-------------	--------------------------------	--------------	----------------------------	-----------------------------	-----------------	-----------------------------------	---------------------------------------	--

GEODYNE CURRENT METER MODEL 920-3

Figure F3



ENVIRONMENT CANADA LIBRARY BURLINGTON



3 9055 1016 7501 4