

QUEEN
HD
9710
.C22
A256
1992



Industry, Science and
Technology Canada

Industrie, Sciences et
Technologie Canada



Canada

IC

STATISTICAL REVIEW OF THE CANADIAN AUTOMOTIVE INDUSTRY: 1992 EDITION

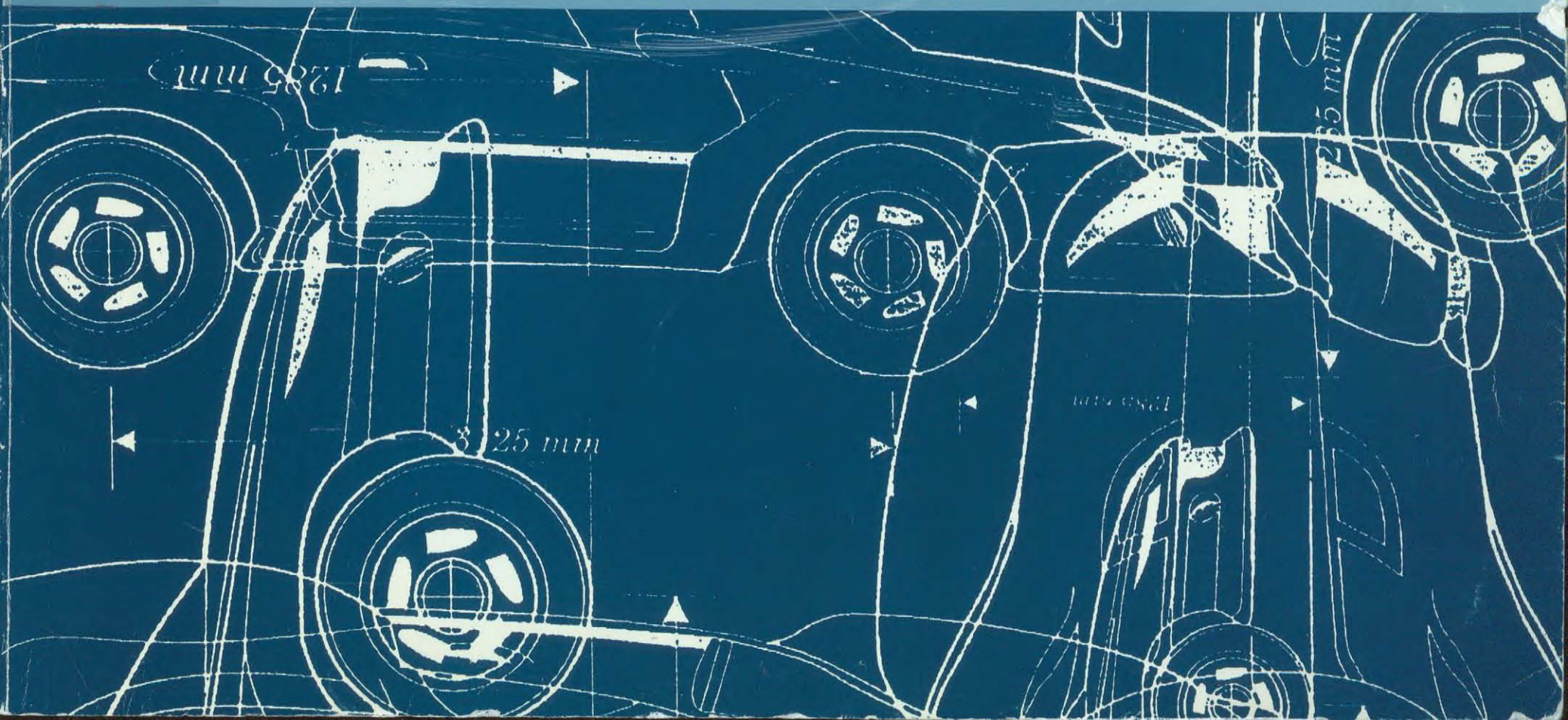

Queen
HD
9710
- C22
A256
1992

STATISTICAL REVIEW OF THE CANADIAN AUTOMOTIVE INDUSTRY: 1992 EDITION

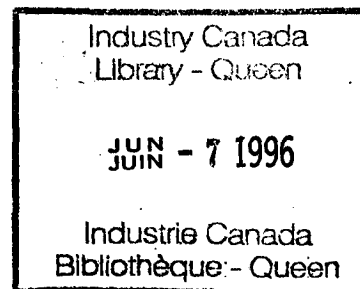

Automotive, Urban Transit and Rail Branch
Industry, Science and Technology Canada
235 Queen Street
OTTAWA, Ont.
K1A 0H5

Tel.: (613) 954-3394

July 1992

© Minister of Supply and Services Canada 1992
Cat. No. C25-7/1992
ISBN 0-662-59108-9

CGS-PU 0025-92-03



AUTOMOTIVE DEVELOPMENTS IN 1991

Continuing flat vehicle sales dominated the Canadian, and the North American automotive industry throughout 1991. A slight decline in Canadian sales (1.3 percent in passenger vehicles and 4 percent in trucks) was overshadowed by a larger decline in the U.S. market (12 percent in passenger cars and 9 percent in trucks) that affected Canadian production of vehicles and parts. Despite this market situation, the Canadian share of vehicle production rose to 17.5 percent of the total North American volume, although the value of vehicle exports remained stable.

As in 1990, some Canadian assembly plants experienced considerable downtime as excess capacity continued to plague the North American market, particularly for the *Big Three*. At the Sainte-Thérèse plant of General Motors, production was halted while preparations were made for the change-over to the new generation of *Camaro* and *Firebird*. At Chrysler, production continued at high levels for the minivan in Windsor, while the Bramalea plant continued to prepare for introduction of the LH series of vehicles in 1992.

Flat vehicle sales, especially for the *Big Three*, continued to affect the Canadian parts sector. Both production of parts and employment in the sector are estimated to have declined, although capital expenditures in the industry increased by more than 5 percent. Parts exports declined by more than 16 percent, reflecting the reduced demand by the *Big Three* in the U.S. Many companies in the sector continued to make improvements in productivity and quality, often

assisted by the Automotive Components Initiative, developed by Industry Science and Technology Canada (ISTC). A major turnaround was made by Magna International, where corporate adjustments led to a profitable year-end.

The Automotive Advisory Committee (AAC), reporting to the Minister of Industry, Science and Technology and Minister for International Trade continued to promote communication and cooperation among industry, labour and government. Major activities of the AAC included: continuing sectoral advice to the Minister for International Trade during negotiations for a North American Free Trade Agreement; the establishment of a committee to review the competitiveness of the Canadian automotive retail distribution system; and the firm establishment of the Automotive Parts Sector Training Council under the guidance of the Automotive Parts Manufacturers Association and the Canadian Autoworkers Union, with initial support of the federal and provincial governments.

Contents

1. Sales

1.1	Retail Sales of Motor Vehicles in Canada	8
1.2	Retail Sales of Motor Vehicles in the U.S.	9
1.3	Canadian Car Sales by Size by North American Companies	10
1.4	U.S. Sales of North American Cars by Size	11
1.5	Canadian Sales of New Passenger Cars by Origin	12
1.6	U.S. Sales of New Passenger Cars by Origin	13
1.7	Road Motor Vehicle Registrations in Canada	14
1.8	International Sourcing Pattern of Original Equipment Parts of Five Major Motor Vehicle Manufacturers (Purchases from In-House and Independent Suppliers)	15

2. Production

2.1	North American Production of Motor Vehicles	18
2.2	North American Production of Passenger Cars	20
2.3	Canadian Truck Production	21
2.4	U.S. Truck Production	22
2.5	Top 10 Vehicle Manufacturers in the World by Total Output, 1989	23
2.6	World Motor Vehicle Production by Country	24
2.7	Canadian Motor Vehicle Production by Industrial Product Price Indexes	25
2.8	Value of Shipments in Canadian Automotive Industries	26

3. Investment

3.1	New Capital Expenditures in Canadian Automotive Industries	28
-----	--	----

4. Trade and Auto Pact Data	
4.1	Total Canadian Trade in Automotive Products32
4.2	Canada-Overseas Trade in Automotive Products33
4.3	Canada-U.S. Trade in Automotive Products34
4.4	Overall Net Production to Net Sales-Value Ratios Achieved by Auto Pact Companies in Canada35
4.5	Canadian Value Added/Cost of Sales Achieved by Auto Pact Producers36
4.6	Total Canadian Value Added by Category of Production for the Four Major Vehicle Manufacturers in Canada37
5. Research and Development	
5.1	Research and Development in the Motor Vehicle Industries40
6. Employment	
6.1	Employment Related to Automotive Manufacturing in Canada42
6.2	Employment Related to Automotive Manufacturing in the U.S.43
6.3	Canadian Automotive Parts Industry by Number of Employees, 198944
7. Major Automotive Plants in Canada	
7.1	Major Motor Vehicle Assembly Plants in Canada46
7.2	A Partial List of Major Automotive Parts Plants in Canada49
7.3	Asian Assembly Investment in Canada and the U.S.55
Selected Publications Available on the Automotive Industry56	
Automotive Associations57	
ISTC Business Service Centres58	

NOTE: Because of the variety of sources from which these statistical tables have been derived or taken, totals do not always agree.

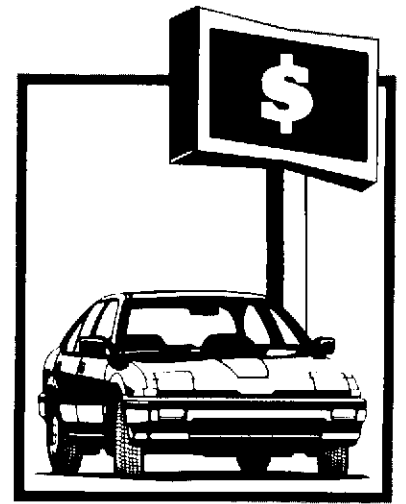

Sales

**Retail Sales of Motor Vehicles in Canada
(Thousands of Units)**

Year	Automobiles			Trucks			Total Vehicles
	Domestic*	Overseas Import**	Total	Domestic*	Overseas Import**	Total	
1965	634	75	709	120	2	122	831
1970	497	143	640	125	9	134	774
1975	836	154	990	310	17	327	1 317
1979	863	140	1 003	381	12	393	1 396
1980	741	191	932	312	22	334	1 266
1981	647	257	904	251	36	287	1 191
1982	489	224	713	167	40	207	920
1983	625	218	843	193	45	238	1 081
1984	725	246	971	274	39	313	1 284
1985	795	342	1 137	345	48	393	1 530
1986	762	329	1 091	368	51	419	1 510
1987	701	364	1 065	412	51	463	1 528
1988	725	332	1 057	460	49	509	1 566
1989	674	319	993	422	68	490	1 483
1990	580	305	885	361	72	433	1 318
1991	573	300	873	348	67	415	1 288

* North American-built (includes Mexico)

** Includes captives

Source: Statistics Canada Catalogue Number 63-007.

**Retail Sales of Motor Vehicles in the U.S.
(Thousands of Units)**

Year	Automobiles			Trucks			Total Vehicles
	Domestic*	Overseas Import**	Total	Domestic*	Overseas Import**	Total	
1965	8 763	569	9 332	1 539	44	1 583	10 915
1970	7 120	1 285	8 405	1 746	65	1 811	10 216
1975	7 053	1 587	8 640	2 249	231	2 480	11 120
1979	8 328	2 300	10 628	3 000	500	3 500	14 128
1980	6 578	2 398	8 976	2 002	484	2 486	11 462
1981	6 206	2 324	8 530	1 852	448	2 300	10 830
1982	5 757	2 222	7 979	2 151	410	2 561	10 540
1983	6 795	2 386	9 181	2 588	464	3 052	12 233
1984	7 951	2 439	10 390	3 484	607	4 091	14 481
1985	8 205	2 834	11 039	3 912	766	4 678	15 717
1986	8 216	3 235	11 451	3 944	923	4 867	16 318
1987	6 871	3 197	10 068	3 915	824	4 739	14 807
1988	7 539	3 099	10 638	4 547	604	5 151	15 789
1989	7 078	2 825	9 903	4 132	506	4 638	14 541
1990	6 897	2 403	9 300	3 956	600	4 556	13 856
1991	6 138	2 038	8 176	3 606	530	4 136	12 312

* North American-built (includes Mexico)

** Includes captives

Source: Motor Vehicle Manufacturers' Association and *Ward's Automotive Reports*.

Table 1.3

**Canadian Car Sales* by Size by North American Companies
(Thousands of Units)**

Year	Sub-compact	Percent of Total	Compact	Percent of Total	Intermediate	Percent of Total	Full-size	Percent of Total	Luxury	Percent of Total	Total Sales
1970	9	1.8	101	20.4	156	31.5	215	43.4	14	2.8	495
1975	75	10.3	186	25.7	229	31.6	223	30.8	12	1.7	725
1979	152	17.6	237	27.5	243	28.2	203	23.5	27	3.1	862
1980	140	18.9	229	30.9	206	27.8	148	20.0	18	2.4	741
1981	137	21.5	198	31.1	184	28.9	105	16.5	13	2.0	637
1982	157	32.4	125	25.8	145	29.9	51	10.5	7	1.4	485
1983	206	33.6	135	22.0	198	32.2	66	10.7	9	1.5	614
1984	235	32.9	179	25.1	207	29.0	79	11.1	14	2.0	714
1985	237	30.3	202	25.8	246	31.5	80	10.2	17	2.2	782
1986	233	30.9	187	24.8	235	31.2	82	10.9	17	2.3	754
1987	107	14.6	298	40.5	230	31.3	68	9.3	32	4.4	735
1988	73	9.7	343	45.6	216	28.7	92	12.2	28	3.7	752
1989	76	11.1	314	45.8	175	25.5	94	13.7	27	3.9	686
1990**	260	28.6	356	39.1	168	18.5	88	9.6	38	4.2	910
1991**	253	30.8	314	38.2	159	19.3	53	6.5	42	5.1	822

* Includes captive imports

** Includes import models

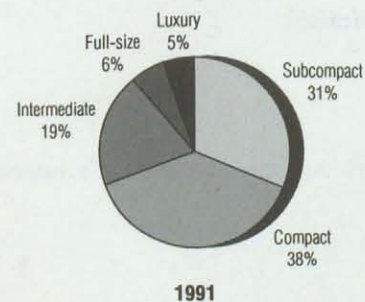

Source: Motor Vehicle Manufacturers' Association by Ward's Classification.

Table 1.4

**U.S. Sales of North American* Cars by Size
(Thousands of Units)**

Year	Sub-compact	Percent of Total	Compact	Percent of Total	Intermediate	Percent of Total	Full-size	Percent of Total	Luxury	Percent of Total	Total Sales
1970	138	1.9	1 157	16.2	2 435	34.0	3 033	42.4	389	5.4	7 152
1975	1 167	17.3	1 679	24.8	1 975	29.2	1 588	23.5	352	5.2	6 761
1979	1 762	21.4	1 936	23.5	2 335	28.4	1 709	20.8	484	5.9	8 226
1980	1 671	25.4	1 675	25.5	1 836	27.9	1 075	16.3	321	4.9	6 578
1981	1 661	26.8	1 523	24.5	1 742	28.1	952	15.3	328	5.3	6 206
1982	1 739	30.2	1 104	19.2	1 618	28.1	928	16.1	367	6.4	5 756
1983	2 035	29.9	925	13.6	2 247	33.1	1 158	17.0	431	6.3	6 796
1984	2 306	29.0	1 309	16.5	2 457	30.9	1 232	15.5	647	8.1	7 951
1985	1 297	15.8	2 563	31.2	2 464	30.0	1 077	13.1	804	9.8	8 205
1986	1 325	16.1	2 461	30.0	2 540	30.9	1 116	13.6	772	9.4	8 214
1987	1 100	15.5	2 389	33.7	2 026	28.6	925	13.1	640	9.0	7 080
1988	1 019	13.5	2 781	36.9	2 017	26.8	1 052	14.0	670	8.9	7 539
1989	926	13.1	2 606	36.8	1 916	27.1	955	13.5	674	9.5	7 077
1990**	928	9.9	2 120	22.8	4 160	44.8	877	9.4	1 210	13.0	9 295
1991**	878	10.7	1 893	23.2	3 589	43.9	676	8.3	1 132	13.9	8 168

* Includes Mexico but does not include captives

** Includes import models

Source: *Ward's Automotive Reports*. Figures from 1970 and 1975 are based on registrations (figures are low because of incomplete reports from some states). Subsequent years are based on retail sales.

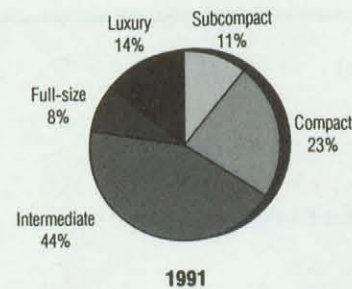

Table 1.5

**Canadian Sales of New Passenger Cars by Origin
(Thousands Units)**

Year	Total Sales Volume	Domestic*		Offshore Imports**		Imports from Japan**	
		Volume	Percent	Volume	Percent	Volume	Percent
1965	709	634	89.4	75	10.6	2	0.3
1970	640	497	77.7	143	22.3	66	10.3
1975	989	836	84.5	154	15.6	96	9.7
1979	1 003	864	86.1	139	13.9	80	8.0
1980	932	741	79.5	191	20.5	138	14.8
1981	904	647	71.6	257	28.4	208	23.0
1982	713	489	68.6	224	31.4	178	25.0
1983	843	625	74.1	218	25.9	177	21.0
1984	971	725	74.7	246	25.3	171	17.6
1985	1 137	795	69.9	342	30.1	199	17.5
1986	1 091	762	69.8	329	30.2	198	18.1
1987	1 065	701	65.8	364	34.2	243	22.8
1988	1 057	725	68.6	332	31.4	244	23.1
1989	993	674	67.9	319	32.1	246	24.7
1990	884	580	65.6	305	34.5	239	27.1
1991	873	573	65.6	300	34.4	238	27.3

* North American-built (includes Mexico)

** Includes captives

Source: Statistics Canada Catalogue Number 63-007.

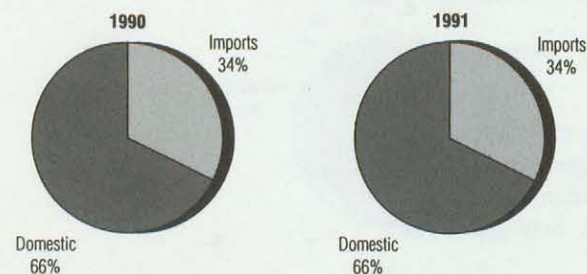

**U.S. Sales of New Passenger Cars by Origin
(Thousands of Units)**

Year	Total Sales Volume	Domestic*		Offshore Imports**		Imports from Japan**	
		Volume	Percent	Volume	Percent	Volume	Percent
1965	9 233	8 673	93.9	469	5.1	18	0.2
1970	8 365	7 116	85.1	1 249	14.9	313	3.7
1975	8 615	7 050	81.8	1 564	18.2	808	9.4
1979	10 647	8 328	78.2	2 319	21.8	1 834	17.2
1980	8 979	6 578	73.3	2 400	26.7	1 908	21.2
1981	8 533	6 206	72.7	2 328	27.3	1 859	21.8
1982	7 979	5 757	72.2	2 222	27.8	1 801	22.6
1983	9 182	6 795	74.0	2 387	26.0	1 916	20.9
1984	10 391	7 952	76.5	2 439	23.5	1 906	18.3
1985	11 039	8 205	74.3	2 834	25.7	2 218	20.1
1986	11 453	8 215	71.7	3 238	28.3	2 376	20.7
1987	10 278	6 886	67.0	3 392	33.0	2 330	22.7
1988	10 638	7 539	70.9	3 099	29.1	2 178	20.5
1989	9 903	7 078	71.5	2 825	28.5	2 048	20.7
1990	9 300	6 897	74.2	2 403	25.8	1 633	17.6
1991	8 176	6 137	75.1	2 038	24.9	1 484	18.2

* North American-built (includes Mexico)

** Includes captive imports for 1980 and subsequent years

Source: *Ward's Automotive Reports*.

**Road Motor Vehicle Registrations in Canada
(Thousands of Units)**

Year	Passenger Automobiles	Trucks and Truck Tractors	Buses	Motorcycles	Mopeds	Other Vehicles	Total
1980	10 256	2 903	53	389	NA*	118	13 719
1981	10 199	3 138	54	407	NA	53	13 851
1982	10 530	3 239	54	431	NA	55	14 309
1983	10 732	3 308	55	466	NA	59	14 620
1984	10 781	3 047	52	470	NA	56	14 406
1985	11 118	3 095	53	453	35	64	14 818
1986	11 586	3 156	56	430	35	72	15 335
1987	11 773	3 508	59	414	34	76	15 864
1988	12 086	3 706	60	370	31	84	16 337
1989	12 811	3 396	62	348	30	72	16 719
1990	12 622	3 867	64	331	28	69	16 981

* Not available

Source: Statistics Canada Catalogue Number 53-219.

International Sourcing Pattern of Original Equipment Parts of Five Major Motor Vehicle Manufacturers*
(Purchases from In-house and Independent Suppliers)
(Millions of Dollars)

Model Year	U.S Purchases from In-house Suppliers in Canada	Canadian Purchases from In-house Suppliers in U.S.	U.S. Purchases from Independent Suppliers in Canada	Canadian Purchases from Independent Suppliers in U.S.
1965	17	522	74	236
1970	454	1 153	487	505
1975	797	2 209	876	1 051
1979	2 362	4 703	1 812	1 560
1980	1 604	3 992	1 253	1 226
1981	2 119	4 957	1 385	1 451
1982	2 892	5 374	1 477	1 844
1983	2 360	5 918	1 922	2 067
1984	3 960	7 813	2 617	3 034
1985	4 621	8 490	3 381	3 871
1986	4 869	9 710	3 736	4 619
1987	4 579	7 251	3 819	4 385
1988	3 979	8 752	3 500	4 838
1989	4 845	8 494	3 486	6 226
1990	4 621	8 981	2 661	5 647
1991	3 148	8 337	2 822	4 434

* General Motors, Ford, Chrysler (includes AMC before 1987), CAMI (starting in 1989) and Navistar

Source: Compiled from company responses to the *Reisman Inquiry* (1965-1977) and company Auto Pact reports (1979-1991).

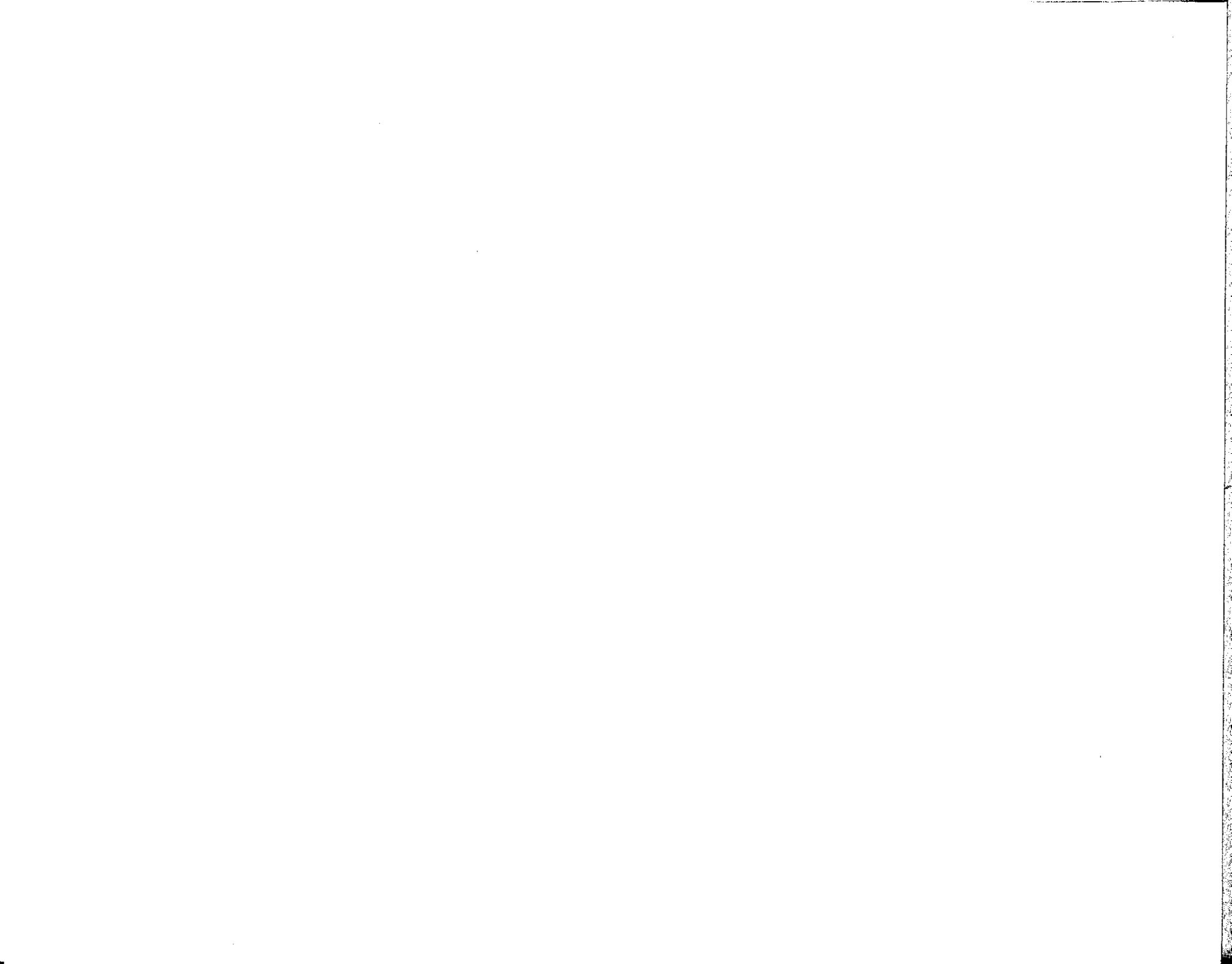

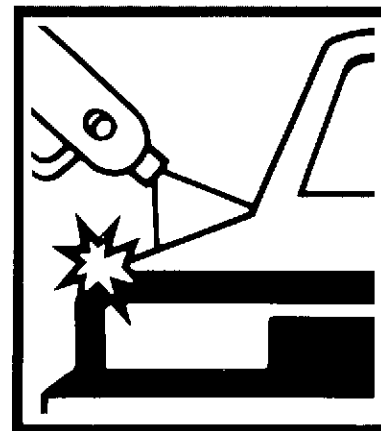

Production

**North American Production of Motor Vehicles
(Thousands of Units)**

Year	Canada		U.S.		North America Total Volume
	Volume	Percent	Volume	Percent	
1965	846	7.1	11 114	92.9	11 960
1970	1 193	12.6	8 263	87.4	9 456
1975	1 442	13.9	8 965	86.1	10 407
1979	1 632	12.5	11 475	87.5	13 107
1980	1 374	14.6	8 010	85.4	9 384
1981	1 280	13.9	7 941	86.1	9 221
1982	1 236	15.0	6 985	85.0	8 221
1983	1 502	14.0	9 226	86.0	10 728
1984	1 830	14.3	10 924	85.7	12 754
1985	1 930	14.2	11 648	85.8	13 578
1986	1 859	14.1	11 317	85.9	13 176
1987	1 648	13.1	10 908	86.9	12 556
1988	1 977	15.0	11 197	85.0	13 174
1989	1 940	15.2	10 851	84.8	12 791
1990	1 922	16.4	9 780	83.6	11 702
1991	1 878	17.5	8 805	82.4	10 683

Source: *Ward's Automotive Reports*.

**North American Production of Motor Vehicles
(Thousands of Units)**

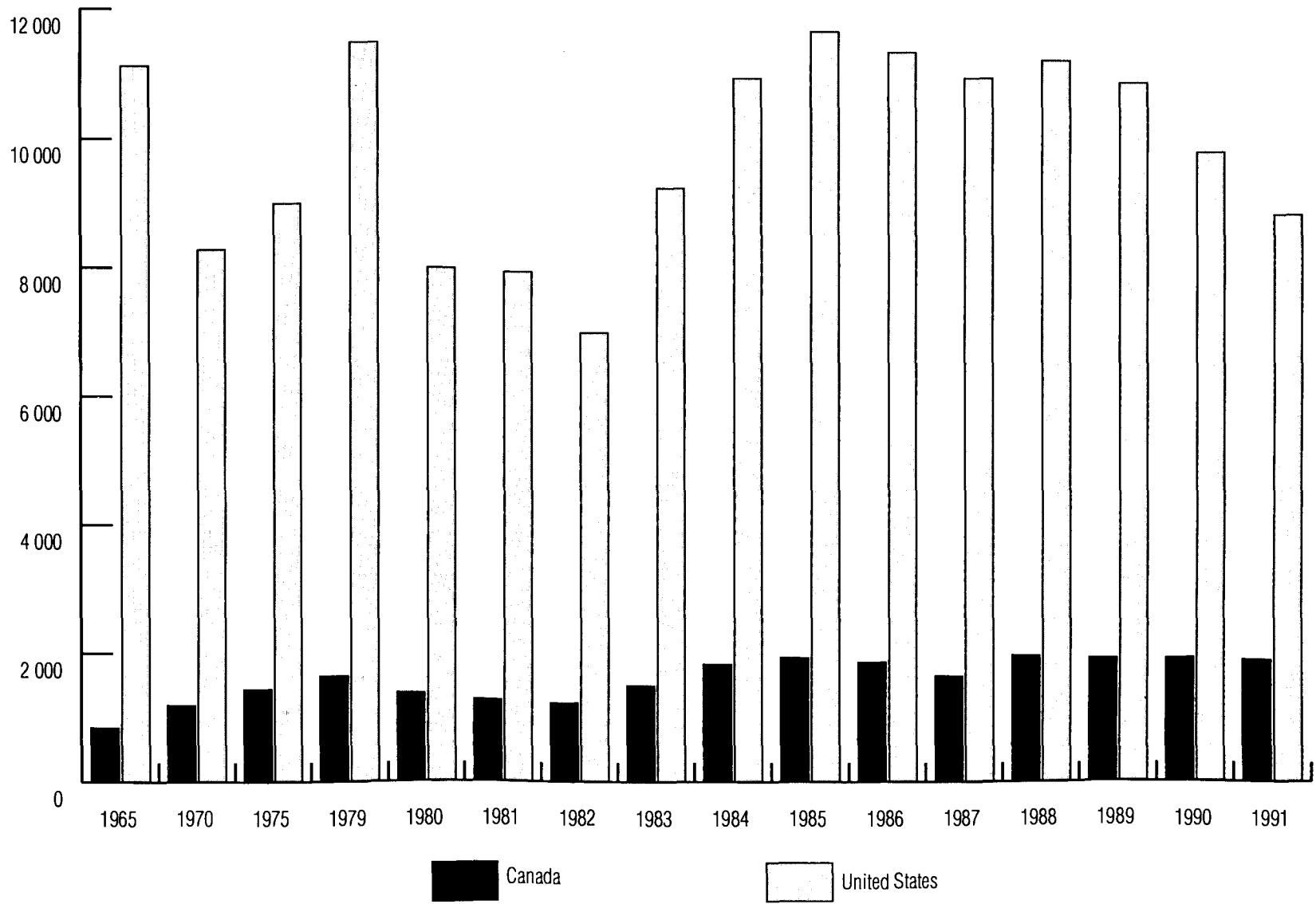

Table 2.2

**North American Production of Passenger Cars
(Thousands of Units)**

Year	Canada		U.S.		North American Total Volume
	Volume	Percent of Total	Volume	Percent of Total	
1965	707	7.0	9 329	93.0	10 036
1970	940	12.6	6 546	87.4	7 486
1975	1 055	13.6	6 706	86.4	7 761
1976	1 146	11.9	8 493	88.1	9 639
1977	1 162	11.2	9 211	88.8	10 373
1978	1 162	11.2	9 174	88.8	10 336
1979	997	10.6	8 422	89.4	9 419
1980	847	11.7	6 372	88.3	7 219
1981	784	11.1	6 251	88.9	7 035
1982	788	13.4	5 073	86.6	5 861
1983	955	12.3	6 782	87.7	7 737
1984	1 023	11.6	7 773	88.4	8 796
1985	1 071	11.6	8 186	88.4	9 257
1986	1 062	11.9	7 829	88.1	8 891
1987	811	10.3	7 100	89.7	7 911
1988	1 028	12.6	7 118	87.4	8 146
1989	1 002	12.8	6 823	87.2	7 825
1990	1 076	13.1	6 078	86.9	7 154
1991	1 045	16.1	5 438	83.9	6 483

Source: *Ward's Automotive Reports*.

**Canadian Truck* Production
(Thousands of Units)**

Year	Light	Percent of Total	Medium and Heavy-Duty	Percent of Total	Total
1975	367	94.8	20	5.2	387
1976	483	96.4	18	3.6	501
1977	576	95.7	26	4.3	602
1978	630	96.0	26	4.0	656
1979	607	95.6	28	4.4	635
1980	506	96.0	21	4.0	527
1981	480	96.6	17	3.4	497
1982	434	96.9	14	3.1	448
1983	539	98.5	8	1.5	547
1984	794	97.8	18	2.2	812
1985	834	97.4	22	2.6	856
1986	771	97.2	22	2.8	793
1987	816	97.4	22	2.6	838
1988	922	97.1	28	2.9	950
1989	914	97.4	24	2.6	938
1990	833	98.0	17	2.0	850
1991	822	98.6	12	1.4	834

* Includes vans

Source: *Ward's Automotive Reports*.

Table 2.4

**U.S. Truck* Production
(Thousands of Units)**

Year	Light	Percent of Total	Medium	Percent of Total	Heavy- Duty	Percent of Total	Total
1965	1 325	76.5	271	15.7	135	7.8	1 731
1970	1 359	80.3	194	11.5	140	8.3	1 693
1975	1 945	85.6	200	8.8	126	5.5	2 271
1976	2 637	88.5	199	6.7	143	4.8	2 979
1977	3 049	88.8	204	5.9	181	5.2	3 434
1978	3 263	88.0	224	6.0	219	5.9	3 706
1979	2 608	85.9	189	6.2	239	7.9	3 036
1980	1 387	83.2	100	6.0	181	10.9	1 668
1981	1 445	85.0	89	5.2	167	9.8	1 701
1982	1 721	90.3	49	2.6	136	7.1	1 906
1983	2 096	86.5	127	5.2	201	8.3	2 424
1984	2 769	90.0	68	2.2	238	7.7	3 075
1985	3 046	90.7	78	2.3	233	6.9	3 357
1986	3 128	92.2	51	1.5	213	6.3	3 392
1987	3 528	92.4	55	1.4	234	6.1	3 817
1988	3 810	92.5	62	1.5	249	6.0	4 121
1989	3 788	93.2	43	1.1	232	5.7	4 062
1990	3 474	95.4	41	1.1	126	3.5	3 641
1991	3 172	94.2	23	0.7	172	5.1	3 367

* Includes vans

Source: *Ward's Automotive Reports.*

Top 10 Vehicle Manufacturers in the World by Total Output, 1989

Company	Total Output (Units)
General Motors — U.S.A	7 611 447
Ford Motor — U.S.A.	6 046 514
Toyota — Japan	4 278 190
Volkswagen — West Germany	3 003 461
Nissan — Japan	2 880 892
Peugeot-Citroen — France	2 687 893
Chrysler — U.S.A.	2 208 629
Renault — France	2 204 915
Fiat — Italy	2 157 827
Honda — Japan	1 811 962

Source: Motor Vehicle Manufacturers' Association (MVMA) of the United States, *World Motor Vehicle Data*, 1991.

**World Motor Vehicle Production by Country
(Thousands of Units)**

	1965	1970	1975	1980	1985	1987	1988	1989	1990	1991
Japan	1 876	5 289	6 941	11 043	12 271	12 249	12 700	13 026	13 487	13 245
U.S.	11 118	8 267	8 991	8 010	11 672	10 975	11 262	11 125	9 888	8 884
Germany*	2 976	3 842	3 186	3 879	4 446	4 614	4 625	4 852	4 661	5 015
France	1 642	2 750	2 861	3 378	3 016	3 493	3 698	3 920	3 295	3 611
Spain	229	536	814	1 182	1 418	1 433	1 866	2 046	1 679	2 082
Canada	852	1 157	1 446	1 373	1 937	1 564	1 960	1 936	1 905	1 911
Italy	1 176	1 854	1 459	1 612	1 573	1 913	2 111	2 221	1 875	1 877
C.I.S.**	634	916	1 964	2 199	2 200	2 100	2 180	2 100	2 000	1 845
South Korea	-	29	36	123	378	977	1 084	1 130	1 322	1 498
U.K.	2 177	2 098	1 648	1 313	1 311	1 342	1 545	1 626	1 296	1 454
Brazil	185	416	930	1 165	967	900	1 069	1 103	914	960

* Includes East and West Germany

** Formerly the Soviet Union

Source: *Automotive News* (ranked by 1991 production).

Canadian Motor Vehicle Production by Industrial Product Price Indexes

Year	Number of Units Produced (Thousands)	Value of SIC 3231 Production (Millions of Dollars)	Unit Value (Dollars)	Index* (1986 = 100)	Motor Vehicle Industry (IPPI)** (1986 = 100)
1986	1 854	24 174	13 039	100.0	100.0
1987	1 635	22 421	13 713	105.2	99.6
1988	1 977	27 981	14 153	108.5	95.2
1989	1 994	27 599	13 845	106.2	94.1
1990	1 918	26 673***	13 907	106.7	94.6
1991	1 903	27 323***	14 283	109.5	97.1

* Index based on unit value (number of units produced /value of production)

** Industrial Product Price Indexes for SIC 3231 based on the actual prices of a select group of vehicles

*** Preliminary data based on Statistics Canada Catalogue Number 31-001

Source: Statistics Canada.

**Value of Shipments in Canadian Automotive Industries
(Millions of Dollars)**

Year	Motor Vehicle Manufacturers	Truck Body and Trailer Manufacturers	Motor Vehicle Parts and Accessories Manufacturers*	Automotive Tire and Tube Manufacturers**	Total
1976	7 276	749	3 418	NA	11 443
1977	8 610	713	4 139	NA	13 462
1978	10 070	861	5 120	NA	16 051
1979	10 724	1 042	4 897	NA	16 663
1980	10 071	978	4 034	NA	15 083
1981	11 403	1 005	4 879	NA	17 287
1982	12 344	743	5 877	NA	18 964
1983	15 591	722	8 358	1 381	26 052
1984	21 263	1 002	11 494	1 697	35 456
1985	24 599	1 148	12 923	1 653	40 323
1986	25 094	1 302	12 922	1 849	41 167
1987	22 154	1 367	12 739	1 699	37 959
1988	26 866	1 631	14 471	1 287	44 255
1989	28 059	1 687	14 718	1 454	45 918
1990	28 248	1 476	13 108	1 550	44 382
1991***	28 995	1 148	11 702	1 350	43 195

* Includes automobile fabric and accessories manufacturers

** Information supplied by companies

*** Estimate based on 1989 census

17 | 30
17
130
86

180 B 211

Source: Statistics Canada Catalogue Number 31-001.

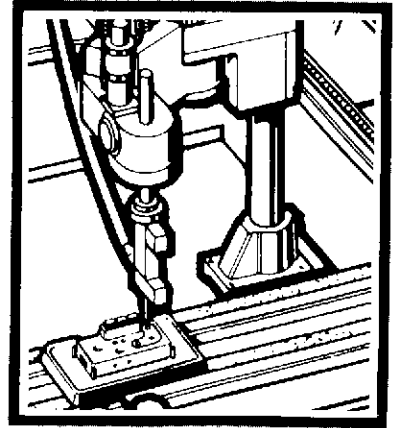

Investment

**New Capital Expenditures In Canadian Automotive Industries
(Millions of Dollars)**

Year	Motor Vehicle Manufacturers (SIC 323)	Truck Body Manufacturers (SIC 324)	Motor Vehicle Parts and Accessories (SIC 325)	Total
1977	153	24	110	287
1978	84	15	204	303
1979	111	42	331	484
1980	136	47	781	964
1981	273	32	667	972
1982	203	34	189	426
1983	463	13	141	617
1984	256	13	171	440
1985	714	9	332	1 055
1986	1 897	19	403	2 319
1987	1 584	27	755	2 366
1988	1 917	21	646	2 584
1989	1 423	30	590	2 043
1990	787	8	457	1 252
1991*	890	11	483	1 384

* Preliminary

Source: Statistics Canada Catalogue Number 61-214.

**New Capital Expenditures in Canadian Automotive Industries
(Millions of Dollars)**

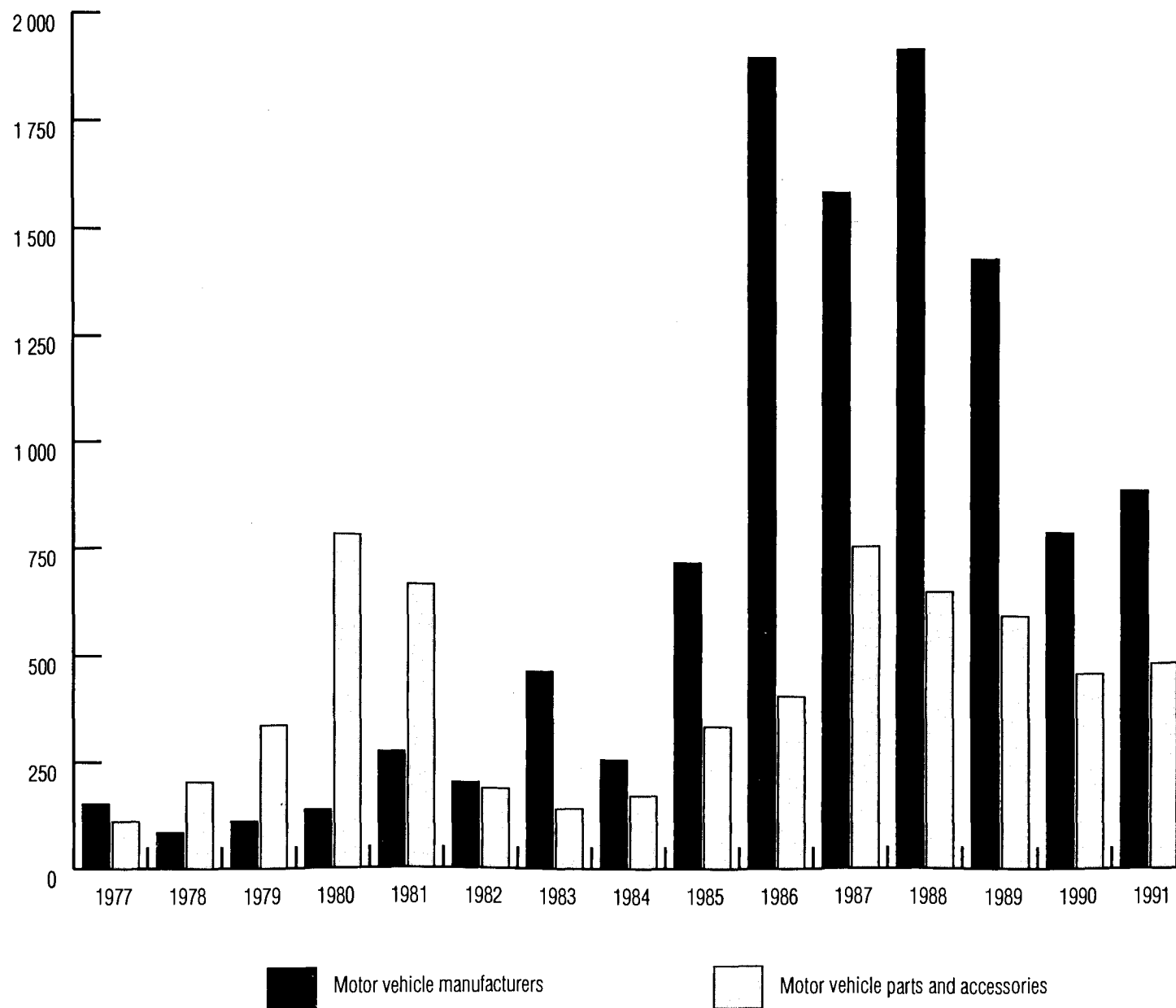

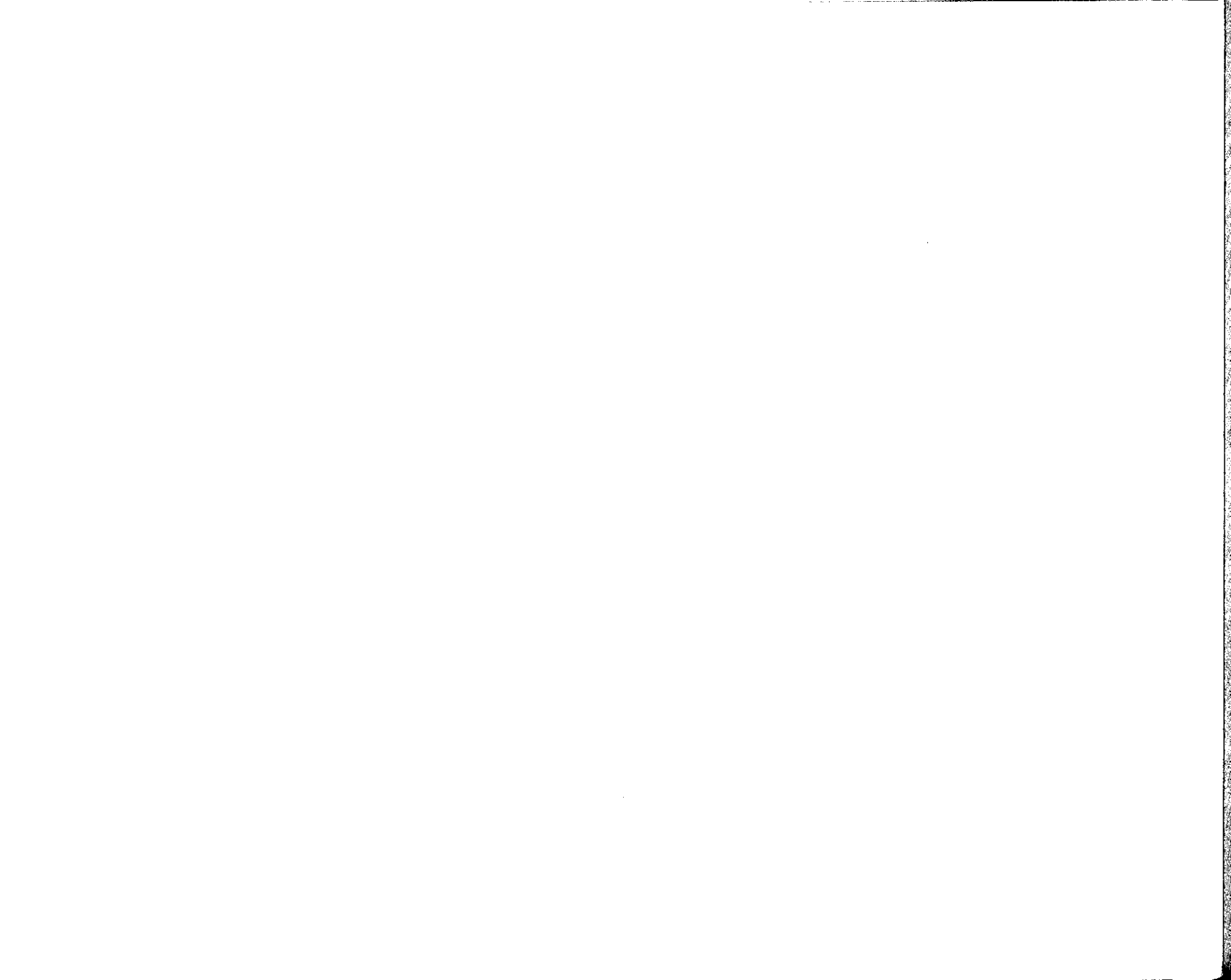

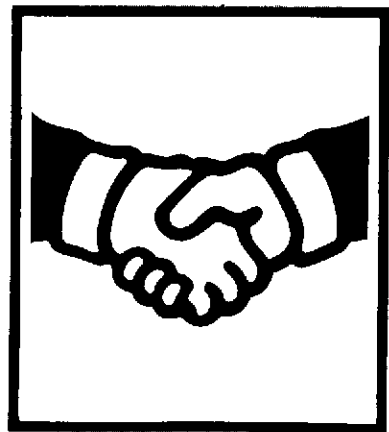

**Trade and Auto
Pact Data**

Total Canadian Trade in Automotive Products*
(Millions of Dollars)

	1965	1970	1975	1980	1985	1987	1988	1989	1990	1991
Canadian Exports										
Cars	156	1 604	3 021	4 859	15 316	13 565	16 482	15 105	16 315	16 513
Trucks and Other Vehicles*	31	664	1 190	2 445	6 609	6 965	7 510	8 214	8 150	7 760
Parts	183	1 226	2 225	3 825	11 819	11 961	12 098	12 035	10 540	9 192
Tires and Tubes	8	18	73	262	637	693	553	694	721	773
Re-exports**	5	9	10	89	134	195	238	261	-	-
Total	383	3 521	6 519	11 480	34 515	33 379	36 881	36 309	35 726	34 238
Canadian Imports										
Cars	207	876	2 548	4 417	11 293	12 347	12 176	11 774	10 664	9 514
Trucks and Other Vehicles*	62	298	987	1 347	2 950	3 706	3 441	3 126	3 076	3 123
Parts	818	2 237	4 631	7 955	18 897	18 228	21 586	20 469	19 191	18 563
Tires and Tubes	12	43	256	354	471	571	594	692	675	725
Total	1 099	3 454	8 422	14 073	33 611	34 852	37 797	36 061	33 605	31 925
Balances										
Cars	(51)	728	473	442	4 023	1 218	4 306	3 331	5 651	6 999
Trucks and Other Vehicles*	(31)	366	203	1 098	3 659	3 259	4 069	5 088	5 075	4 637
Parts	(635)	(1 011)	(2 406)	(4 130)	(7 078)	(6 267)	(9 488)	(8 434)	(8 651)	(9 371)
Tires and Tubes	(4)	(25)	(183)	(92)	166	122	(41)	2	46	48
Re-exports**	5	9	10	89	134	195	238	261	-	-
Total	(716)	67	(1 903)	(2 593)	904	(1 473)	(916)	248	2 121	2 313

* Includes buses, specialty vehicles and motor homes

** Figures for re-exports unavailable for 1990 and 1991

Source: Statistics Canada Catalogue Numbers 65-001P and 11-001E (1965-1989). Data for 1990 and 1991 compiled by ISTC using Statistics Canada definitions.

Canada-Overseas Trade in Automotive Products*
(Millions of Dollars)

	1965	1970	1975	1980	1985	1987	1988	1989	1990	1991
Canadian Exports										
Cars	82	66	163	407	39	60	156	108	146	154
Trucks and Other Vehicles*	10	75	258	227	187	127	147	151	121	90
Parts	32	99	180	420	307	382	346	369	491	522
Tires and Tubes	4	3	5	31	45	32	33	29	13	13
Re-exports**	5	9	10	89	134	195	238	261	-	-
Total	133	252	616	1 174	712	796	920	918	771	779
Canadian Imports										
Cars	113	217	365	1 029	2 727	3 656	3 571	3 598	3 787	4 618
Trucks and Other Vehicles*	2	23	45	130	380	424	365	302	349	362
Parts	21	130	206	355	1 459	1 831	1 630	2 449	2 986	3 272
Tires and Tubes	2	19	82	208	207	261	243	248	234	250
Total	138	389	698	1 722	4 773	6 172	5 809	6 597	7 356	8 502
Balances										
Cars	(31)	(151)	(202)	(622)	(2 688)	(3 596)	(3 415)	(3 490)	(3 641)	(4 464)
Trucks and Other Vehicles*	8	52	213	97	(193)	(297)	(218)	(151)	(228)	(272)
Parts	11	(31)	(26)	65	(1 152)	(1 449)	(1 284)	(2 080)	(2 495)	(2 750)
Tires and Tubes	2	(16)	(77)	(177)	(162)	(229)	(210)	(219)	(221)	(237)
Re-exports**	5	9	10	89	134	195	238	261	-	-
Total	(5)	(137)	(82)	(548)	(4 061)	(5 376)	(4 889)	(5 679)	(6 585)	(7 723)

* Includes buses, specialty vehicles and motor homes

** Figures for re-exports unavailable for 1990 and 1991

Source: Statistics Canada Catalogue Numbers 65-001P and 11-001E (1965-1989). Data for 1990 and 1991 compiled by ISTC using Statistics Canada definitions.

**Canada-U.S. Trade in Automotive Products
(Millions of Dollars)**

	1965	1970	1975	1980	1985	1987	1988	1989	1990	1991
U.S. Imports from Canada										
Cars	74	1 538	2 858	4 452	15 277	13 505	16 326	14 997	16 169	16 359
Trucks and Other Vehicles*	21	589	932	2 218	6 422	6 838	7 363	8 063	8 029	7 670
Parts	151	1 127	2 045	3 405	11 512	11 579	11 752	11 666	10 049	8 670
Tires and Tubes	4	15	68	231	592	661	520	665	708	760
Total	250	3 269	5 903	10 306	33 803	32 583	35 961	35 391	34 955	33 459
Canadian Imports from the U.S.										
Cars	94	659	2 183	3 388	8 566	8 691	8 605	8 176	6 877	4 896
Trucks and Other Vehicles*	60	275	942	1 217	2 570	3 282	3 076	2 824	2 726	2 761
Parts	797	2 107	4 425	7 600	17 438	16 397	19 956	18 020	16 205	15 291
Tires and Tubes	10	24	174	146	264	310	351	444	441	475
Total	961	3 065	7 724	12 351	28 838	28 680	31 988	29 464	26 249	23 423
Balances										
Cars	(20)	879	675	1 064	6 711	4 814	7 721	6 821	9 292	11 463
Trucks and Other Vehicles*	(39)	314	(10)	1 001	3 852	3 556	4 287	5 239	5 303	4 909
Parts	(646)	(980)	(2 380)	(4 195)	(5 926)	(4 818)	(8 204)	(6 354)	(6 156)	(6 621)
Tires and Tubes	(6)	(9)	(106)	85	328	351	169	221	267	285
Total	(711)	204	(1 821)	(2 045)	4 965	3 903	3 973	5 927	8 706	10 036

* Includes buses, specialty vehicles and motor homes

Sources: Statistics Canada Catalogue Numbers 65-001P and 11-001E (1965-1989). Data for 1990 and 1991 compiled by ISTC using Statistics Canada definitions.

Overall Net Production to Net Sales-Value Ratios* Achieved by Auto Pact Companies
in Canada (Percent)**

	Model Year										
	1975	1980	1983	1984	1985	1986	1987	1988	1989	1990	1991
Passenger Vehicles											
(Required Ratio: range 95-100)											
Net Sales-Value Ratio Achieved											
(All Companies)	122	106	196	173	174	177	162	153	138	158	170
Commercial Vehicles											
(Required Ratio: range 75-100)											
Net Sales-Value Ratio Achieved	101	115	272	231	192	191	159	133	188	197	203
(All Companies)											
Buses											
(Required Ratio: range 85-100)											
Net Sales-Value Ratio Achieved	114	199	243	312	324	239	163	189	230	342	330
(All Companies)											

* Net production to net sales-value ratio is the ratio of the total value of Canadian vehicle production to the total net sales value of vehicle sales for all Auto Pact companies

** Based on 18 major manufacturers

Source: Compiled from company Auto Pact reports to ISTC.

Canadian Value Added/Cost of Sales Achieved by Auto Pact Producers*
(Millions of Dollars)

	1975	1980	1983	1984	1985	1986	1987	1988	1989	1990	1991
Cost of Sales in Canada of Auto Pact Producers (Model Year)	4 545	8 757	6 752	10 281	13 022	15 022	15 340	15 440	15 402	13 244	12 487
Total Canadian Value Added (Model Year)	2 987	4 659	5 847	8 504	10 210	11 282	10 113	11 035	11 438	11 238	10 599
Difference between Cost of Sales and Canadian Value Added	1 558	4 020	905	1 777	2 812	3 720	5 227	4 405	3 964	3 728	1 888
Canadian Value Added											
Total achieved Canadian Value Added as Percentage of Cost of Sales	66	53	87	83	78	75	66	72	74	85	85

* Based on 18 major manufacturers

Source: Auto Pact company reports to ISTC.

Total Canadian Value Added by Category of Production for the Four Major Vehicle Manufacturers in Canada*
(Millions of Dollars)

Year	Non-Parts CVA** in Vehicle Production	Parts CVA in Vehicle Production	CVA in Original Equipment Parts Exported	Total CVA Produced	Parts CVA as Percent of Total CVA
	A	B	C	D = A+B+C	(B+C)/D
1965	380	576	100	1 056	64.0
1970	483	510	651	1 644	70.6
1975	876	733	1 106	2 715	67.7
1980	1 322	1 087	1 755	4 164	68.3
1981	1 345	1 273	2 218	4 836	72.2
1982	1 457	1 233	2 256	4 946	70.5
1983	1 604	1 446	2 542	4 592	71.3
1984	1 981	1 797	3 917	8 695	77.2
1985	2 182	3 094	5 095	10 371	79.0
1986	2 432	2 501	5 532	10 465	76.8
1987	2 365	1 856	5 124	9 345	74.7
1988	2 877	3 114	5 044	11 035	73.9
1989	3 057	2 562	4 877	10 496	70.9
1990	3 132	3 401	4 551	11 084	71.7
1991	2 998	2 577	4 268	9 842	69.5

* General Motors, Ford, Chrysler (includes AMC before 1987) and CAMI (starting in 1989)

** Canadian Value Added

Source: 1965-1977 data prepared by the Reisman Commission; 1978-1991 data prepared by ISTC.

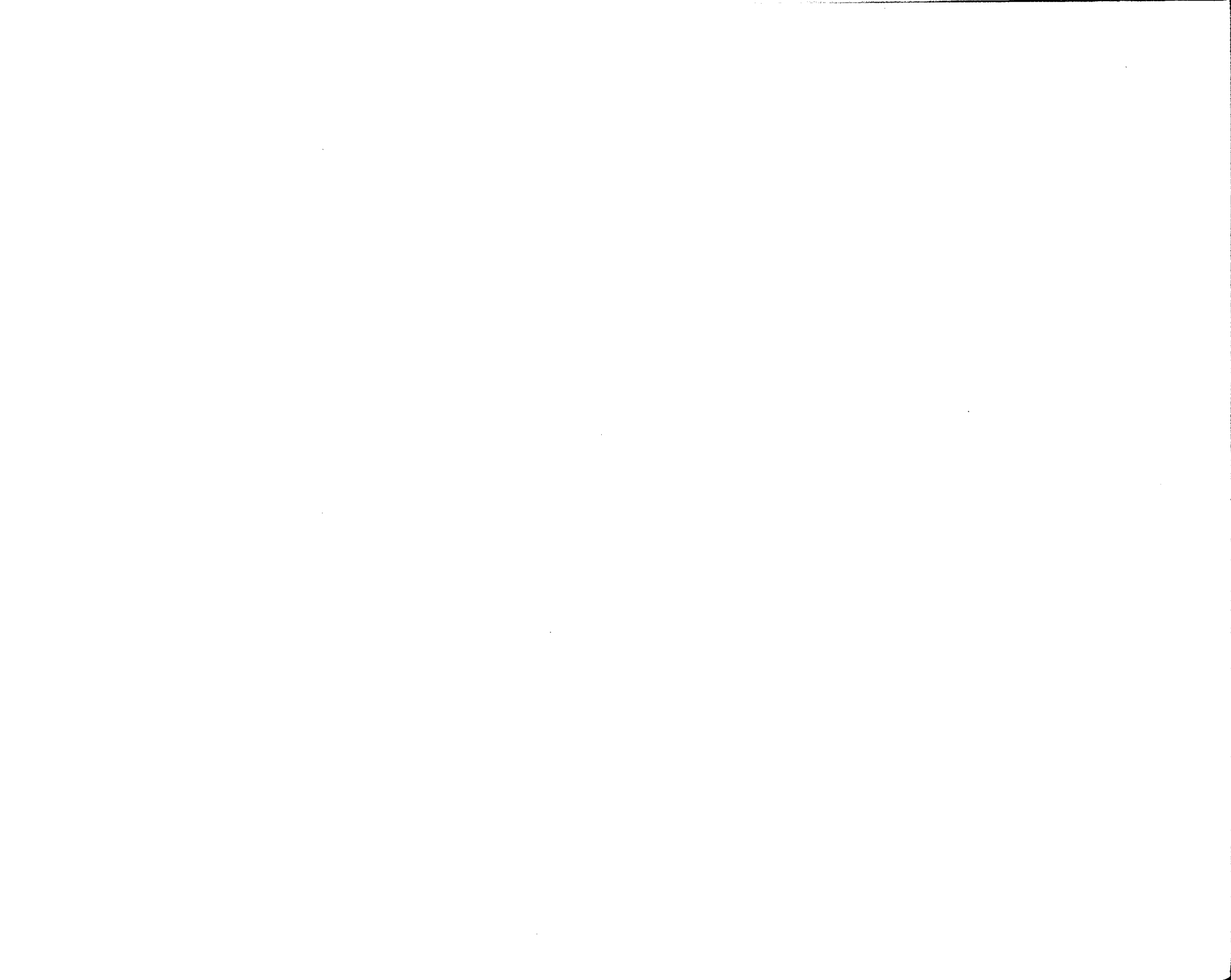

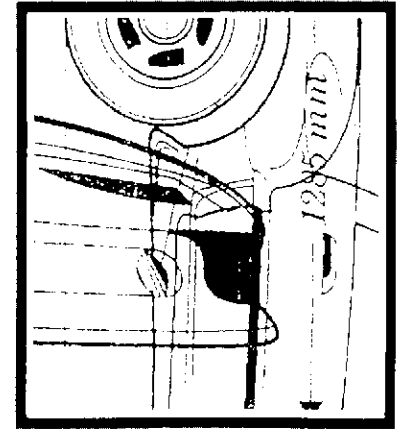

Research and Development

**Research and Development in the Motor Vehicle Industries
(SIC* 323, 324 and 325)**

Year	Number of R&D Performers	Total R&D Personnel (Person-years)	Total R&D Expenditures (Millions of Dollars)	R&D Expenditures As Percentage of Shipments
1975	28	545	12	0.10
1977	25	685	21	0.16
1979	24	735	32	0.19
1981	33	890	49	0.28
1982	32	825	53	0.28
1983	33	960	66	0.27
1984	25	890	70	0.21
1985	40	1 050	79	0.20
1986	56	1 255	90	0.23
1987	60	1 200	104	0.29
1988	58	1 345	103	0.24
1989	47	1 145	92	0.21

* Based on 1980 Standard Industrial Classification

Source: Statistics Canada.

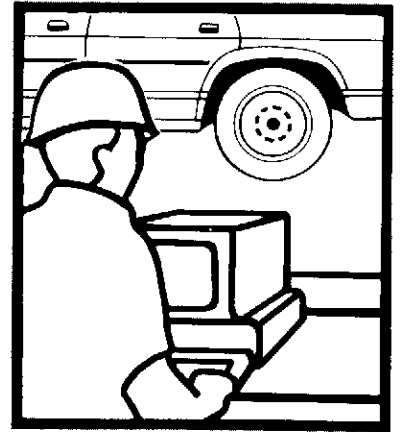

Employment

Table 6.1

**Employment Related to Automotive Manufacturing in Canada
(Thousands of Units)**

Year	Motor Vehicle Assembly (SIC 323)	Truck Bodies and Trailers (SIC 324)	Automotive Parts and Acc. (SIC 325)	Total
1965	42.9	5.4	31.9	80.2
1970	38.1	10.1	38.9	87.1
1975	45.3	17.7	42.6	105.6
1980	44.9	14.8	52.0	111.7
1981	44.3	13.1	55.7	113.1
1982	42.2	9.7	53.6	105.5
1983	47.6	8.6	64.7	120.9
1984	54.3	10.1	77.4	141.8
1985	56.9	11.4	84.4	152.7
1986	53.5	12.9	85.2	151.6
1987	52.0	13.4	88.8	154.2
1988	52.7	15.3	94.3	162.3
1989	55.4	16.2	96.3	167.8
1990*	52.7	14.5	88.0	155.2
1991*	48.9	12.3	76.2	137.4

* Figures are ISTC estimates based on the historical trend of the *Census of Manufacturers'* employment

Source: Statistics Canada Catalogue Number 42-251B.

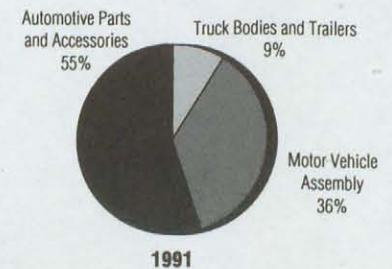

**Employment Related to Automotive Manufacturing in the U.S.
Annual Average (Thousands)**

Year	Total Motor Vehicle Equipment (SIC 371)	Motor Vehicles (SIC 3711)	Truck and Bus Bodies (SIC 3713)	Parts and Accessories (SIC 3714)	Automotive Stampings (SIC 3465)
1972	875	415	46	383	105
1973	977	462	51	430	111
1974	908	416	55	403	96
1975	792	375	46	353	82
1976	881	416	44	399	100
1977	938	440	48	424	110
1978	977	452	51	444	114
1979	995	464	46	444	115
1980	789	368	40	350	95
1981	789	359	37	363	94
1982	705	321	31	325	82
1983	773	363	32	344	89
1984	867	389	40	388	99
1985	873	403	38	389	102
1986	843	381	38	379	101
1987	842	368	44	384	99
1988	850	358	75	397	96
1989	856	355	44	408	103
1990	801	311	41	403	100
1991	734	312	37	385	94

Source: U.S. Bureau of Labor Statistics.

Canadian Automotive Parts Industry by Number of Employees, 1989

Number of Employees	Number of Establishments	Percent of Total Establishments	Value of Shipments (Millions of Dollars)	Percent of Total Shipments
Fewer than 4	88	13.0	15 266	0.1
5 to 49	253	37.3	539 177	3.5
50 to 499	302	44.5	6 339 530	41.0
500 to 999	26	3.8	2 162 830	14.0
1 000 or more	10	1.5	6 390 532	41.4
Total	679	100.0	15 447 335	100.0

Source: Statistics Canada Catalogue Number 42-251B.

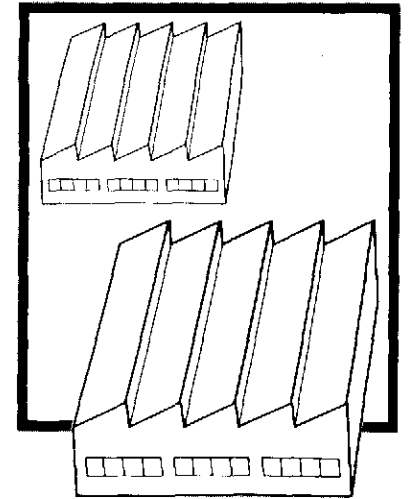

**Major Automotive Plants
in Canada**

Major Motor Vehicle Assembly Plants in Canada

Company/Plant Name	Location	Products
Light Vehicle Manufacturers		
Canadian Automobile Mfg. Inc. (CAMI)	Ingersoll, Ontario	Firefly, Sprint, Swift, Tracker
Chrysler Canada Ltd.	Bramalea, Ontario Windsor, Ontario Windsor, Ontario	LH Series Caravan, Voyager, Mini Ram van Ram van, Ram wagon
Ford of Canada Ltd.	Oakville, Ontario Oakville, Ontario St. Thomas, Ontario	Tempo, Topaz F series (pick-up trucks) Crown Victoria, Grand Marquis
Honda Canada Inc.	Alliston, Ontario	Hatchback Civic
Hyundai Auto Canada Inc.	Bromont, Quebec	Sonata
General Motors of Canada Ltd.	Oshawa, Ontario Oshawa, Ontario Oshawa, Ontario Scarborough, Ontario Sainte-Thérèse, Quebec	Lumina Regal Chev/GMC light trucks Chev van, Vandura Camaro/Firebird
Toyota Canada Inc.	Cambridge, Ontario	Corolla
Volvo Canada Inc.	Halifax, Nova Scotia	740/940 series
Truck Manufacturers		
Canadian Kenworth (division of Paccar Canada Ltd.)	Sainte-Thérèse, Quebec	Heavy-duty trucks
Freightliner of Canada Ltd.	St. Thomas, Ontario	Heavy-duty trucks
Mack Canada Inc.	Oakville, Ontario	Heavy-duty trucks

Major Motor Vehicle Assembly Plants in Canada

Company/Plant Name	Location	Products
Truck Manufacturers		
Navistar International Corporation Canada	Chatham, Ontario	Medium-duty trucks
Pacific Truck and Trailer Ltd.	North Vancouver, British Columbia	Heavy-duty trucks
Western Star Trucks Inc.	Kelowna, British Columbia	Heavy-duty trucks
Bus Manufacturers		
Greyhound Canada Inc.	Saint-Eustache, Quebec	Urban transit buses
Motor Coach Industries Ltd.	Winnipeg, Manitoba	Highway buses
New Flyer Industries Ltd.	Winnipeg, Manitoba	Urban transit buses
Ontario Bus Industries Inc.	Mississauga, Ontario	Urban transit buses
Prévost Car Inc.	Sainte-Claire, Quebec	Highway buses
Trailer Manufacturers		
Advance Engineered Products	Regina, Saskatchewan	Bulk tank trailers
Bedarco-McGruer Inc.	Montreal, Quebec	Bulk tank trailers
Fruehauf Canada Inc.	Ingersoll, Ontario	Lowbed and dry van semi-trailers

Major Motor Vehicle Assembly Plants in Canada

Company/Plant Name	Location	Products
Trailer Manufacturers		
Hutchison Industries	North York, Ontario	Bulk tank trailers
Manac Inc.	Beauce-Sud, Quebec	Lowbed and bulk tank trailers, semi-trailers
Remtec Inc.	Chambly, Quebec	Lowbed and bulk tank trailers
Westank-Willock	Regina, Saskatchewan	Bulk tank trailers
Specialty Vehicle Manufacturers		
Amertek Inc.	Woodstock, Ontario	Crash, fire and rescue vehicles
Frink/Eastern Steel Products	Cambridge, Ontario	Snowblowers, sweeper equipment
Paul Demers et Fils	Belœil, Quebec	Ambulances
Tri-Star Industries Limited	Yarmouth, Nova Scotia	Ambulances
Superior Emergency Equipment	Red Deer, Alberta	Fire trucks
Sweeprite Mfg. Inc.	Regina, Saskatchewan	Sweepers
UTDC	Kingston, Ontario	Military vehicles
Vehma International	Newmarket, Ontario	Electric vans

Source: Compiled from information supplied by the companies.

A Partial List of Major Automotive Parts Plants in Canada

Company/Plant Name	Location	Main Products
In-house Facilities		
Chrysler Canada Ltd.		
Trim plant	Ajax, Ontario	Door panels, seat cushions, backs
Aluminum casting plant	Etobicoke, Ontario	Pistons, water pump bodies, transmissions, transfer cases
Trim plant	Stratford, Ontario	Soft interior trim components
Trim plant	Guelph, Ontario	Plastic automotive components
Ford Motor Company of Canada Ltd.		
Niagara glass plant	Niagara Falls, Ontario	Automotive glass
Essex engine plant	Windsor, Ontario	V6 engines
Ensite engine plant #1	Windsor, Ontario	V8 engines
Foundry and casting plant	Windsor, Ontario	Iron castings
Essex aluminum plant	Windsor, Ontario	Aluminum castings
Ford Electronics Manufacturing Corp.	Markham, Ontario	Radio and electronic components

A Partial List of Major Automotive Parts Plants in Canada

Company/Plant Name	Location	Main Products
General Motors of Canada Ltd.		
Fabrication plant	Oshawa, Ontario	Stampings, batteries, radiators, instrument clusters, plastics, reaction injection moulding
Engine plant	St. Catharines, Ontario	V6 and V8 engines
Foundry	St. Catharines, Ontario	Metal castings (ferrous and non-ferrous)
Axle plant	St. Catharines, Ontario	Axles, disc brakes, spark plugs, front suspensions, transmission components
Trim plant	Windsor, Ontario	Trim sets, door covers
Transmission plant	Windsor, Ontario	Front-wheel-drive automatic transmissions
Tire and Tube Manufacturers		
Bridgestone/Firestone Canada Inc.	Joliette, Quebec	Passenger tires
Goodyear Canada Inc.	Medicine Hat, Alberta Napanee, Ontario Valleyfield, Quebec	Passenger, truck, bus and off-highway tires
Michelin Tires (Canada) Ltd.	Bridgewater, Nova Scotia Granton, Nova Scotia Waterville, Quebec	Passenger, truck, bus and off-highway tires
Trent Rubber Services Ltd.	Lindsay, Ontario	Tubes
Uniroyal-Goodrich Canada Inc.	North-Kitchener, Ontario* South-Kitchener, Ontario	Passenger, truck, bus and off-highway tires
United Tire and Rubber Company Ltd.	Rexdale, Ontario	Truck, bus, and off-highway tires

* Company has announced plant closure by December 1992

A Partial List of Major Automotive Parts Plants in Canada

Company/Plant Name	Location	Main Products
Foreign-owned Independent Manufacturers (larger facilities)		
AP Parts of Canada	Rexdale, Ontario	Mufflers, tail and exhaust pipes
Allied Signal Corp.	Chatham, Ontario London, Ontario Stratford, Ontario	Induction systems, engine cooling fans, electric drive cooling modules, cooling air blowers, EGR valves, electronic vacuum regulators, sensors and actuators, secondary air valves, etc.
Bellemar Parts Industries Canada Inc.	Alliston, Ontario	Automotive seating
Budd Canada Inc.	Kitchener, Ontario Winnipeg, Manitoba	Frames, engine heaters
F&P Manufacturing	Tottenham, Ontario	Structural frame stampings
Gates Canada	Brantford, Ontario	Rubber hose and tubing
Hayes-Dana Inc.	Barrie, Ontario Burlington, Ontario Cambridge, Ontario Georgetown, Ontario Magog, Quebec Pickering, Ontario St. Catharines, Ontario Thorold, Ontario	Drive shafts, frames, axles, etc.
Johnson Controls	Lachine, Quebec St. Thomas, Ontario Winnipeg, Manitoba	Batteries
Kralinator Filters (Division of Hayes-Dana)	Cambridge, Ontario	Oil, fuel and air filters

A Partial List of Major Automotive Parts Plants in Canada

Company/Plant Name	Location	Main Products
Foreign-owned Independent Manufacturers (larger facilities)		
Lear Seating Canada	Ajax, Ontario Whitby, Ontario Lindsay, Ontario Kitchener, Ontario	Automotive seating
Moog Canada Ltd.	Brampton, Ontario	Steering parts, suspension parts, stampings
PPG Canada Inc.	Toronto, Ontario Mississauga, Ontario Whitby, Ontario	Glass for automobiles, adhesives, coatings, paint, phosphating compounds
Rockwell International of Canada Ltd.	Chatham, Ontario Tilbury, Ontario Mississauga, Ontario Bracebridge, Ontario Milton, Ontario	Coil springs, brakes, mechanical stampings, plastic components
TRW Canada, Thompson Products Division	St. Catharines, Ontario	Steering components, valves, electro-mechanical devices
Volkswagen Canada Inc.	Barrie, Ontario	Transmission parts, brake parts, wheels
Walker Exhausts	Cambridge, Ontario	Mufflers, tail and exhaust pipes
Waterville T.G. Inc.	Waterville, Quebec	Rubber products, padded auto instrument panels

A Partial List of Major Automotive Parts Plants in Canada

Company/Plant Name	Location	Main Products
Canadian-owned Companies		
ABC Group of Companies	Rexdale, Ontario	Blow-moulded automotive components
A.G. Simpson Co. Ltd.	Cambridge, Ontario Oakville, Ontario Oshawa, Ontario Scarborough, Ontario Windsor, Ontario	Stampings
Alcan Automotive Castings	St. Catharines, Ontario	Aluminum cylinder heads, aluminum intake manifolds
Butler Metal Products Co. Ltd.	Cambridge, Ontario	Stampings
Canadian General Tower Ltd.	Cambridge, Ontario	Vinyl seat covers
Complax Corporation (The)	Windsor, Ontario Cobourg, Ontario	Compression and injection-moulded components
Court Industries Limited	St. Catharines	Surface treatment services, chrome and zinc-plating, bonderizing, screw machine products, transmission parts
Cmila Plastic Industries Ltd.	Bolton, Ontario	Trim
Do-Ray Lamp Company (Canada)	Toronto, Ontario	Truck lighting and safety equipment
Dominion Automotive Industries	Toronto, Ontario	Protective lighting, mirrors, directional signals
Fabricated Steel Products Ltd.	Windsor, Ontario	Stampings

A Partial List of Major Automotive Parts Plants in Canada

Company/Plant Name	Location	Main Products
Canadian-owned Companies		
Huron Steel Products	Windsor, Ontario	Stampings
Kendan Manufacturing Ltd.	Windsor, Ontario	Diesel engine components
Linamar Machine Limited	Guelph, Ontario	Transmission and brake parts
Magna International Incorporated	Newmarket, Ontario	Seatings, interior trim
Atoma Division	Brampton, Ontario	Stampings, exterior parts
Cosma Division	Concord, Ontario	Plastic interior and exterior parts
Decoma Division	Concord, Ontario	Steel engine components
Tesma Division		
National Auto Radiator Manufacturing Co. Ltd.	Windsor, Ontario	Stampings
Stelco Inc. (parts manufacturing only)	Gananoque, Ontario Toronto, Ontario Brantford, Ontario	Fasteners and forgings
Tamco Ltd.	Windsor, Ontario	Gear-shift levers, steering-column jackets
Woodbridge Foam Corporation	Tillsonburg, Ontario Toronto, Ontario Woodbridge, Ontario	Sets, other foam rubber components

Asian Assembly Investment in Canada and the U.S.

Company	Location	Announced Capacity (Thousands)	Date Open	Products
Canada				
Toyota	Cambridge, Ontario	70	1988	Cars
Honda	Alliston, Ontario	100	1986	Cars
Hyundai	Bromont, Quebec	100	1989	Cars
CAMI	Ingersoll, Ontario	200	1989	Cars/Trucks (sports utility)
U.S.				
Toyota	Georgetown, Kentucky	200	1993	Cars
	Georgetown, Kentucky	200	1988	Cars
	Fremont, California	100	1992	Trucks (light)
NUMMI	Fremont, California	250	1984	Cars
Nissan	Smyrna, Tennessee	240	1983	Cars/Trucks (light)
	Smyrna, Tennessee	200	1992	Cars
	Avon Lake, Ohio (Ford)	100	1992	Trucks (light)
Honda	Marysville, Ohio	360	1982	Cars
	Liberty, Ohio	150	1991	Cars
Diamond Star	Bloomington-Normal, Illinois	240	1988	Cars
Mazda	Flat Rock, Michigan	240	1987	Cars
Subaru-Isuzu	Lafayette, Indiana	220	1989	Cars/Trucks (sports utility and light)

Selected Publications Available on the Automotive Industry

Available from Industry, Science and Technology Canada*

Automotive Research and Development Capability in Canada —

January 1991

Automotive Trade Statistics — March 1992

Directory of Canadian Automotive Parts Manufacturers

Directory of Canadian Vehicle Manufacturers

Industrial Competitiveness — A Sectoral Perspective

Restructuring in the North American Industry — Summer 1989

Statistical Analysis of the Directory Automotive Research and Development

Capability in Canada — January 1991

Tools for Competitiveness — Federal Programs and Services

of Interest to the Auto Parts Industry — Spring 1990

Available from Business Service Centres

Industry Profiles:

Automotive Aftermarket Parts

Automotive Original Equipment Parts

Automotive Tires

Heavy-Duty Trucks

Light Motor Vehicles

Specialty Vehicles

Urban and Intercity Buses

Available from Statistics Canada

Employment, earnings and hours (monthly) — Catalogue Number 72-002

Fuel consumption survey, passenger cars, light trucks and vans (quarterly) —

Catalogue Number 53-007

Fuel consumption survey (annual) — Catalogue Number 53-226

Capital and repair expenditures manufacturing sub-industries —

Catalogue Number 61-214

Monthly survey of manufacturing — Catalogue Number 31-001

New motor vehicle sales (monthly) — Catalogue Number 63-007

Preliminary statement of international trade (monthly) —

Catalogue Number 65-001P

Road motor vehicles, registrations (annual) — Catalogue Number 53-219

Transportation Equipment Industries — Catalogue Numbers 42-251B, 3231;

3241-3244; 3251-3257; 3299

The Daily — Catalogue Number 11-001E

Transportation equipment industries (annual) — Catalogue Number 42-251

* Limited copies available

Automotive Associations

Association of International Automobile Manufacturers of Canada

Suite 700
210 Dundas Street West
TORONTO, Ont.
M5G 2E8
Tel.: (416) 595-5333
Fax: (416) 595-8226

Automotive Industries Association of Canada

1272 Wellington Street
OTTAWA, Ont.
K1Y 3A7
Tel.: (613) 728-5821
Fax: (613) 728-6021

Automotive Parts Manufacturers' Association of Canada

Suite 516
195 The West Mall
ETOBICOKE, Ont.
M9C 5K1
Tel.: (416) 620-4220
Fax: (416) 620-9730

Canadian Association of Japanese Automobile Dealers (CAJAD)

Suite 101
1 Eva Road
ETOBICOKE, Ont.
M9C 4Z5
Tel.: (416) 620-9717
Fax: (416) 620-0392

Canadian Auto Workers' (CAW)

205 Placer Court, North York
WILLOWDALE, Ont.
M2H 3H9
Tel.: (416) 497-4110
Fax: (416) 495-6559

Canadian Bus Association

Suite 900
155 Queen Street
OTTAWA, Ont.
K1P 6L1
Tel.: (613) 238-1800
Fax: (613) 563-9596

Canadian Recreational Vehicle Association

Suite 200
670 Bloor St. West
TORONTO, Ont.
M6G 1L2
Tel.: (416) 533-7800
Fax: (416) 533-4795

Canadian Transportation Equipment Association

49 Pearl Street
ST. THOMAS, Ont.
N5P 2P5
Tel.: (519) 631-0414
Fax: (519) 631-1855

Canadian Truck Trailer Manufacturers' Association

P.O. Box 294
KLEINBURG, Ont.
L0J 1C0
Tel.: (416) 893-1689
Fax: (416) 893-2392

Federation of Automobile Dealer Associations of Canada

85 Renfrew Drive
MARKHAM, Ont.
L3R 0N9
Tel.: (416) 940-4959
Fax: (416) 940-6870

Japan Automobile Manufacturers' Association of Canada

Suite 1406
2 Sheppard Ave. East
WILLOWDALE, Ont.
M2N 5Y7
Tel.: (416) 222-9515
Fax: (416) 226-6774

Motor Vehicle Manufacturers' Association

Suite 1602
25 Adelaide Street East
TORONTO, Ont.
M5C 1Y7
Tel.: (416) 364-9333
Fax: (416) 367-3221

Pacific Automotive Co-Operation Inc.

Suite 1408
2 Sheppard Ave. East
WILLOWDALE, Ont.
M2N 5Y7
Tel.: (416) 222-0700
Fax: (416) 226-6774

Rubber Association of Canada (The)

Suite 308
89 Queensway West
MISSISSAUGA, Ont.
L5B 2V2
Tel.: (416) 270-8322
Fax: (416) 270-2640

Society of the Plastics Industry of Canada

Suite 104
1262 Don Mills Rd.
DON MILLS, Ont.
M3B 2W7
Tel.: (416) 449-3444
Fax: (416) 449-5685

ISTC Business Service Centres

These centres have been established at headquarters and in every regional office to provide clients with a gateway into the complete range of ISTC services, information products, programs and expertise.

REGIONAL OFFICES

NEWFOUNDLAND

ISTC
Suite 504
Atlantic Place
215 Water Street
P.O. Box 8950
ST. JOHN'S, Nfld.
A1B 3R9
Tel.: (709) 772-ISTC
Fax: (709) 772-5093

PRINCE EDWARD ISLAND

ISTC
Suite 400
National Bank Tower
Confederation Court Mall
134 Kent Street
P.O. Box 1115
CHARLOTTETOWN, P.E.I.
C1A 7M8
Tel.: (902) 566-7400
Fax: (902) 566-7450

NOVA SCOTIA

ISTC
5th Floor
Central Guaranty Trust Tower
1801 Hollis Street
P.O. Box 940, Station M
HALIFAX, N.S.
B3J 2V9
Tel.: (902) 426-ISTC
Fax: (902) 426-2624

NEW BRUNSWICK

ISTC
12th Floor
Assumption Place
770 Main Street
P.O. Box 1210
MONCTON, N.B.
E1C 8P9
Tel.: (506) 857-ISTC
Fax: (506) 851-2384

QUEBEC

ISTC
Suite 3800
800 Tour de la Place Victoria
P.O. Box 247
MONTREAL, Que.
H4Z 1E8
Tel.: (514) 283-8185
or 1-800-361-5367
Fax: (514) 283-3302

ONTARIO

ISTC
4th Floor
Dominion Public Building
1 Front Street West
TORONTO, Ont.
M5J 1A4
Tel.: (416) 973-ISTC
Fax: (416) 954-1385

MANITOBA

ISTC
8th Floor
330 Portage Avenue
P.O. Box 981
WINNIPEG, Man.
R3C 2V2
Tel.: (204) 983-ISTC
Fax: (204) 983-2187

SASKATCHEWAN

ISTC
Suite 401
119-4th Avenue South
SASKATOON, Sask.
S7K 5X2
Tel.: (306) 975-4400
Fax: (306) 975-5334

ALBERTA

ISTC
Suite 540
Canada Place
9700 Jasper Avenue
EDMONTON, Alta.
T5J 4C3
Tel.: (403) 495-ISTC
Fax: (403) 495-4507

ISTC
Suite 1100
510 - 5th Street Southwest
CALGARY, Alta.
T2P 3S2
Tel.: (403) 292-4575
Fax: (403) 292-4578

BRITISH COLUMBIA

ISTC
Suite 900
Scotia Tower
650 West Georgia Street
P.O. Box 11610
VANCOUVER, B.C.
V6B 5H8
Tel.: (604) 666-0266
Fax: (604) 666-0277

YUKON

ISTC
Suite 210
300 Main Street
WHITEHORSE, Y.T.
Y1A 2B5
Tel.: (403) 667-3921
Fax: (403) 668-5003

NORTHWEST TERRITORIES

ISTC
10th Floor
Precambrian Building
P.O. Bag 6100
YELLOWKNIFE, N.W.T.
X1A 2R3
Tel.: (403) 920-8568
Fax: (403) 873-6228

HEADQUARTERS

ISTC
1st Floor, East Tower
235 Queen Street
OTTAWA, Ont.
K1A 0H5
Tel.: (613) 952-ISTC
Fax: (613) 957-7942

