

**FRENCH INVESTMENT
IN CANADA
1985-1990**



**INVESTMENT
CANADA**

**INVESTISSEMENT
CANADA**

TABLE OF CONTENTS - FRENCH INVESTMENT TO CANADA 1985-1990

4.30	Types of Investment	All & Direct	Assets
4.31		All & Direct	Frequencies
4.40	Industry Sectors	All	Assets
4.41		All	Frequencies
4.42		Direct	Assets
4.43		Direct	Frequencies
4.50	Ontario: Spreadsheet Summary		
5.00	Prairie Provinces: An Overview:		
5.1	Prairie Provinces: Graphical Summary:		
5.10	Overview	All	Assets
5.11		All	Frequencies
5.12		Direct	Assets
5.13		Direct	Frequencies
5.14	Comparison of Provinces	All	Assets & Frequ.
5.15		Direct	Assets & Frequ.
5.20	Prairie Provinces: Spreadsheet Summary		
5.3	Manitoba: Graphical Summary:		
5.30	Overview	Direct	Assets
5.31	Overview	Direct	Frequencies
5.40	Manitoba: Spreadsheet Summary		
5.5	Saskatchewan: Graphical Summary:		
5.50	Overview	Direct	Assets
5.51		Direct	Frequencies
5.60	Saskatchewan: Spreadsheet Summary		
5.7	Alberta: Graphical Summary:		
5.70	Overview	All	Assets
5.71		All	Frequencies
5.72		Direct	Assets
5.73		Direct	Frequencies
5.80	Alberta: Spreadsheet Summary		
6.00	British Columbia: An Overview		
6.1	British Columbia: Graphical Summary:		
6.10	Overview	Direct	Assets
6.11		Direct	Frequencies
6.20	Types of Investment	Direct	Assets & Frequ.
6.30	Industry Sectors	Direct	Assets
6.31		Direct	Frequencies
6.50	British Columbia: Spreadsheet Summary		

TABLE OF CONTENTS - FRENCH INVESTMENT TO CANADA 1985-1990

7.00	Urban Centres: An Overview		
7.1	Urban Centres: Graphical Summary		
7.10	Overview	All	Assets
7.11		All	Frequencies
7.12		Direct	Assets
7.13		Direct	Frequencies
7.2	Montreal: Graphical Summary:		
7.20	Comparison with Quebec	All	Assets & Frequ.
7.21		Direct	Assets & Frequ.
7.22	Types of Investment	All	Assets & Frequ.
7.23		Direct	Assets & Frequ.
7.24	Industry Sectors	All	Assets
7.25		All	Frequencies
7.26		Direct	Assets
7.27		Direct	Frequencies
7.30	Montreal: Spreadsheet Summary		
7.4	Toronto: Graphical Summary:		
7.40	Comparison with Ontario	All	Assets & Frequ.
7.41		Direct	Assets & Frequ.
7.42	Types of Investment	All	Assets & Frequ.
7.43		Direct	Assets & Frequ.
7.44	Industry Sectors	All	Assets
7.45		All	Frequencies
7.46		Direct	Assets
7.47		Direct	Frequencies
7.50	Toronto: Spreadsheet Summary		
7.6	Calgary: Graphical Summary:		
7.60	Comparison with Alberta	All	Assets & Frequ.
7.61		Direct	Assets & Frequ.
7.62	Industry Sectors	All & Direct	Assets
7.63		All & Direct	Frequencies
7.70	Calgary: Spreadsheet		
7.8	Vancouver: Graphical Summary:		
7.80	Comparison with B.C.	Direct	Assets & Frequ.
7.81	Industry Sectors	Direct	Assets & Frequ.
7.90	Vancouver: Spreadsheet		

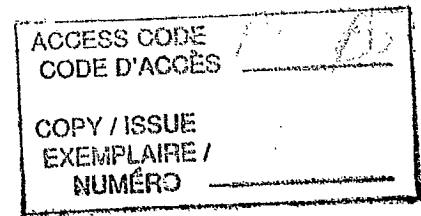
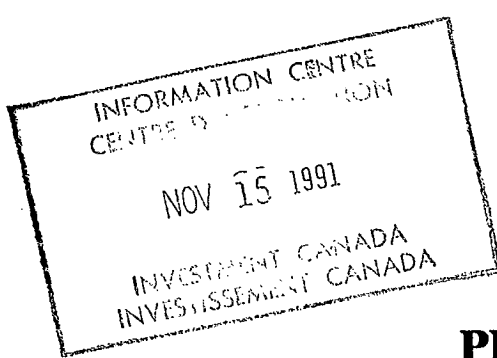

HG
5152
.E7

PREFACE

The analysis in this report is based on investments filed with Investment Canada, either as notices of non-reviewable investments or as applications for review, in the period June 30, 1985 to March 31, 1990. The primary purpose of the analysis is to identify investors' locational and sectoral preferences as reflected in their investment decisions.

For completeness, the analysis is based on frequency of investments (number of transactions) and asset values. However, the frequency data are much more useful for purposes of analysis. The asset value data are of limited value in indicating investors' preferences for a number of reasons. The values used are not transaction values. They are planned investments in the first or second year of operations in the case of new business investments and the book value of the Canadian business in the case of acquisitions. The value data are also significantly skewed by a few large acquisitions. Finally, the data have not been adjusted to eliminate proposed transactions that are known not to have been implemented. This latter weakness in the database is not statistically significant with respect to the analysis based on frequency of investments but does further distort the analysis based on asset values.

Also for completeness the data include direct, indirect and incidental investments although each section contains a separate analysis based only on direct investments. Direct investments are investments for the establishment of new businesses and acquisitions of Canadian businesses, either through the acquisition of their voting interests or assets, where the transaction took place in Canada but exclude those acquisitions where the Canadian transaction was part of, or incidental to, a larger international transaction. The latter are referred to in this report as incidental investments. An indirect investment is the acquisition of control of a Canadian business through

acquisition of control of its parent outside Canada. It will be obvious to readers that indirect and incidental investments are of limited value in analyzing investors' preferences for locations within Canada as in most cases the primary focus of such investments are business operations in one or more other countries.

Two further qualifications of the data and hence the analysis based on it should be noted. First, within the Investment Canada database each investment is identified with a single province - the one with the largest number of employees of the business being acquired. In many cases, there are other provinces in which the acquired business has significant operations. Second, the data for urban centres were compiled on the basis of postal codes and the definitions of urban centres were those used by Canada Post. These definitions are somewhat narrower than the definitions of Census Metropolitan Areas used by Statistics Canada.

TABLE OF CONTENTS - FRENCH INVESTMENT TO CANADA 1985-1990

<u>File #</u>	<u>Region: Summary</u>	<u>Investment Type</u>	<u>Measurement</u>
1.00	Executive Summary - Canada: An Overview		
1.10	Canada: Graphical Summary:		
1.20	Comparison of Provinces	All	Assets & Frequ.
1.21		Direct	Assets & Frequ.
1.30	Types of Investment	All & Direct	Assets
1.31		All & Direct	Frequencies
1.40	Industry Sectors	All	Assets
1.41		All	Frequencies
1.42		Direct	Assets
1.43		Direct	Frequencies
1.50	Canada: Spreadsheet Summary		
2.00	Nova Scotia: An Overview		
2.10	Nova Scotia: Graphical Summary:		
2.20	Overview	Direct	Assets
2.21		Direct	Frequencies
2.50	Nova Scotia: Spreadsheet Summary		
3.00	Quebec: An Overview		
3.10	Quebec: Graphical Summary:		
3.20	Overview	All	Assets
3.21		All	Frequencies
3.22		Direct	Assets
3.23		Direct	Frequencies
3.30	Types of Investment	All & Direct	Assets
3.31		All & Direct	Frequencies
3.40	Industry Sectors	All	Assets
3.41		All	Frequencies
3.42		Direct	Assets
3.43		Direct	Frequencies
3.50	Quebec: Spreadsheet Summary		
4.00	Ontario: An Overview		
4.10	Ontario: Graphical Summary:		
4.20	Overview	All	Assets
4.21		All	Frequencies
4.22		Direct	Assets
4.23		Direct	Frequencies

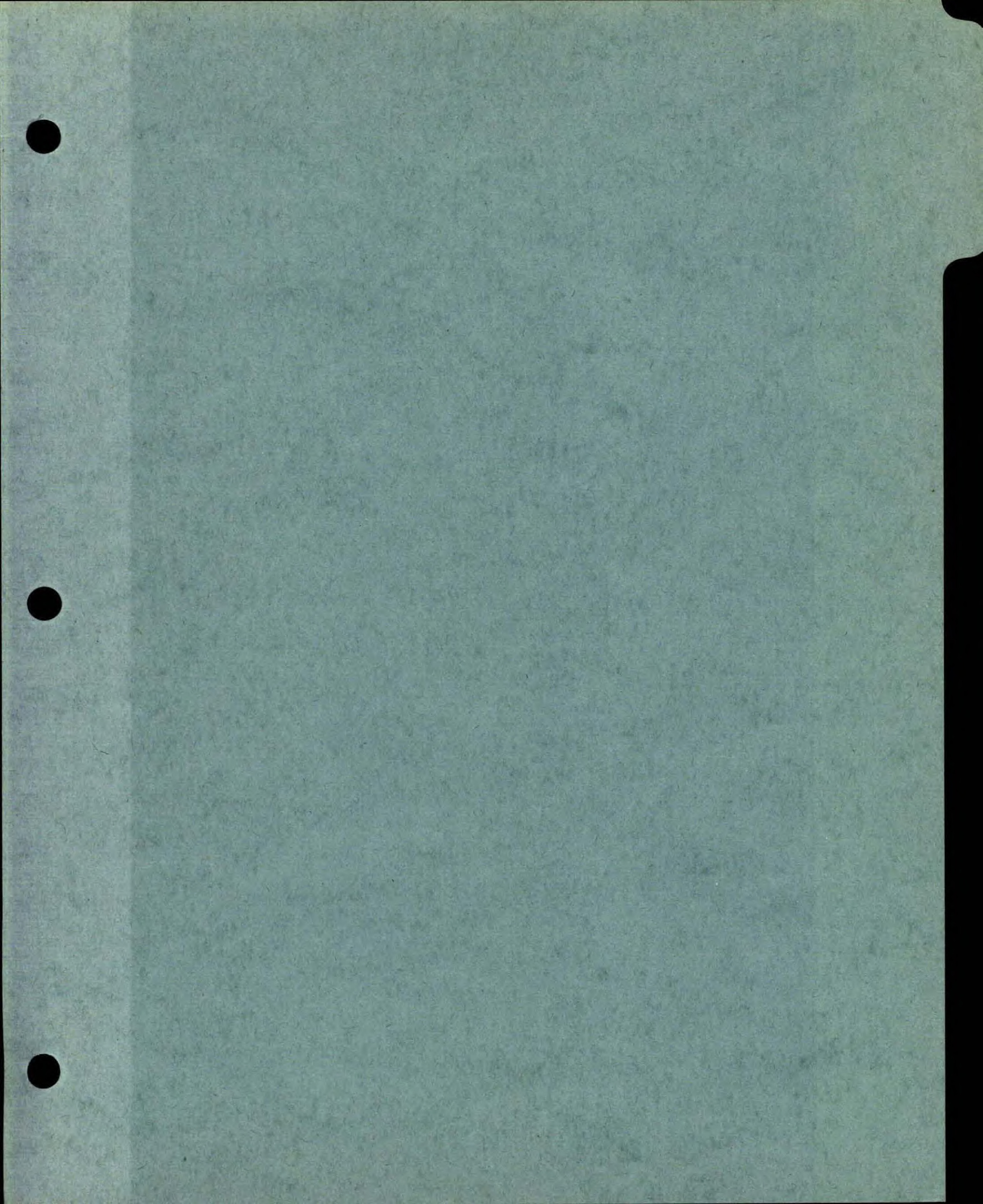

FRANCE - CANADA - AN OVERVIEW

REGION:	TYPE OF INVESTMENT:	TOTAL ASSET VALUE (000's):	TOTAL FREQUENCY:
Canada	All	4,151,962	192
	Direct	3,228,348	170
Nova Scotia	Direct	70,000	1
Quebec	All	1,184,739	100
	Direct	1,140,430	95
Ontario	All	1,785,909	60
	Direct	1,106,972	46
Manitoba	Direct	3,800	2
Saskatchewan	Indirect	179,994	1
Alberta	All	780,789	15
	Direct	760,415	13
British Columbia	Direct	146,731	13
MAJOR CITIES:			
Montreal	All	278,028	40
	Direct	271,156	38
Toronto	All	881,055	13
	Direct	747,817	9
Calgary	All	686,363	4
	Direct	673,026	3
Vancouver	Direct	4,207	2

FRANCE - CANADA - AN OVERVIEW

REGIONAL FOCUS OF INVESTMENT

Ontario and Quebec are the primary targets of French investment. Ontario received 43% of the total asset value of investment, while Quebec drew 29%. Alberta (19%), Saskatchewan (4%), and British Columbia (4%) followed.

Quebec was the most frequent destination of French investment with 52% of the total transactions in Canada. Ontario (31%), Alberta (8%), and British Columbia (7%) followed.

The relatively low asset value and high frequency of investment to Quebec is attributable to numerous small businesses initiated in the manufacturing, wholesale trade, and business service sectors.

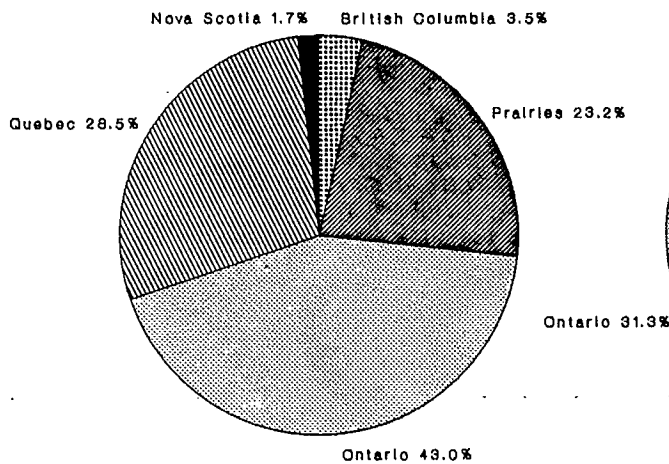

Total Asset Value

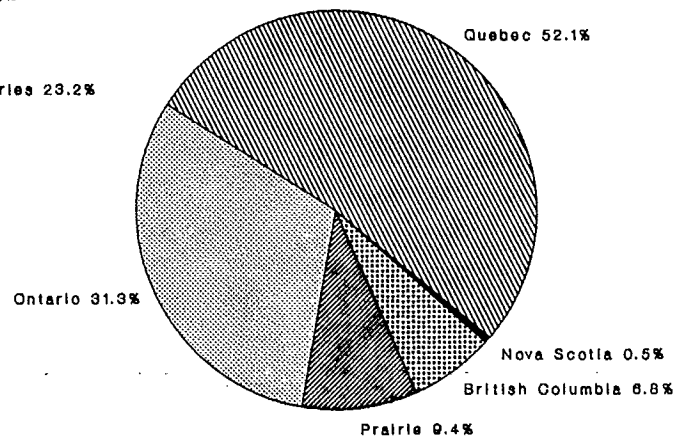

Total Frequency

includes direct, indirect and incidental investment

FRANCE - CANADA - AN OVERVIEW

TYPES OF INVESTMENT

Direct investment comprises 78% of the asset value and 89% of the frequency of all investment. New business accounts for a modest 5% of the asset value of direct investment. In contrast, 38% of the direct investment transactions involve new businesses. Again the especially high frequency and low asset values of new business in the manufacturing, wholesale trade, and business service sectors explain this discrepancy.

TOTAL ASSETS

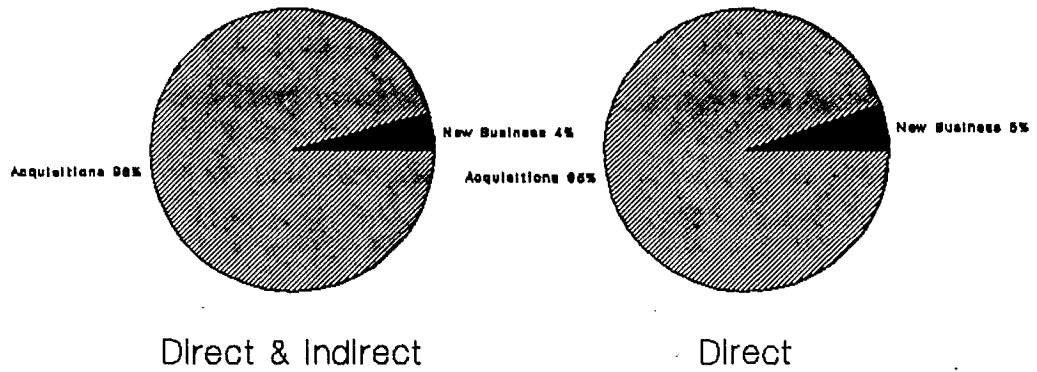

TOTAL FREQUENCIES

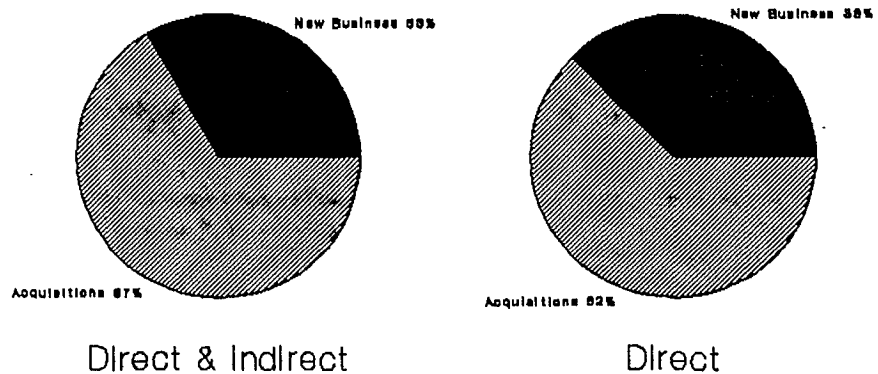

FRANCE - CANADA - AN OVERVIEW

INDUSTRY SECTORS

The dominant industry sectors, wholesale trade and manufacturing, attract 40% and 39% respectively, of the total asset value of French investment to Canada. Mining (7%), finance and insurance (4%), and retail trade (3%) industries follow receiving significantly less investment.

Manufacturing and wholesale trade sectors are also the most frequented with 34% and 33% respectively of the total French investment transactions to Canada. Business services (9%), retail trade (7%), and mining (6%) trail.

TOTAL ASSETS

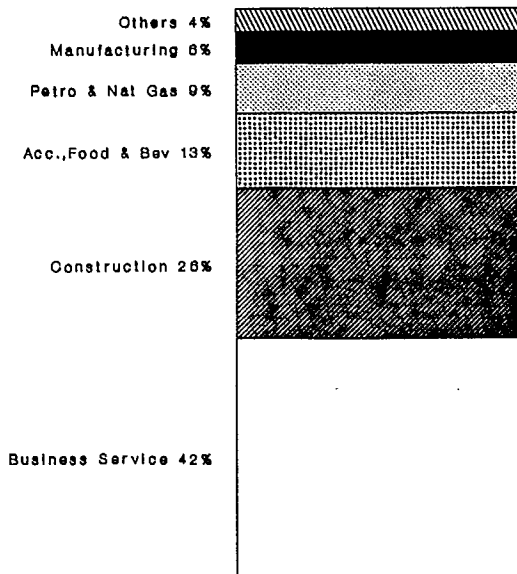

New Business

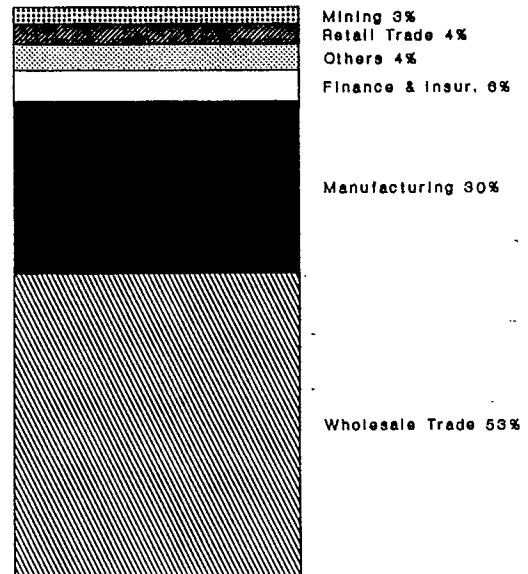

Acquisitions

direct investment only

FRANCE - CANADA - AN OVERVIEW

INDUSTRY SECTORS

TOTAL FREQUENCIES

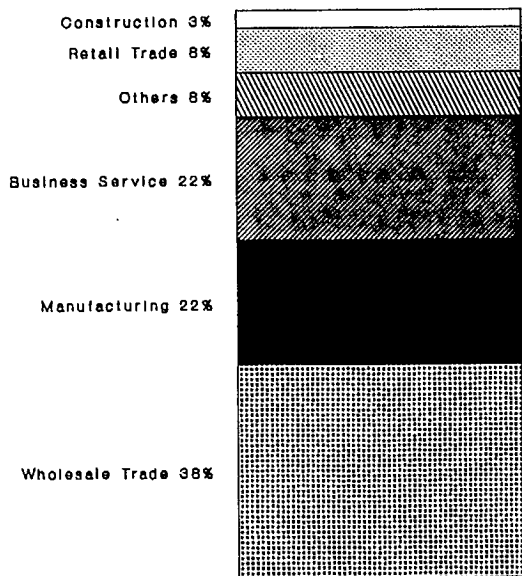

New Business

includes direct, indirect and incidental investment

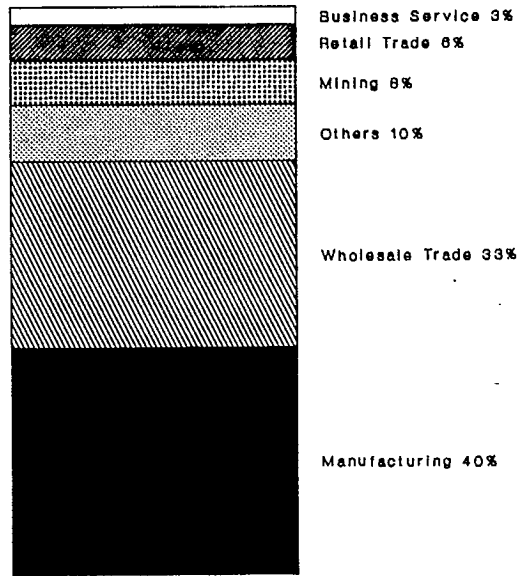

Acquisitions

FRANCE - CANADA 1985-1990 COMPARISON BETWEEN PROVINCES

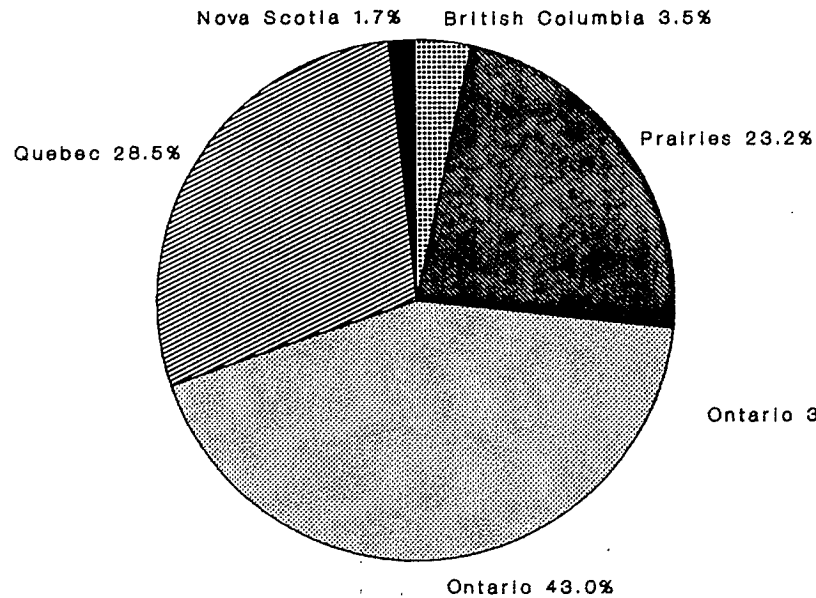

Total Asset Value

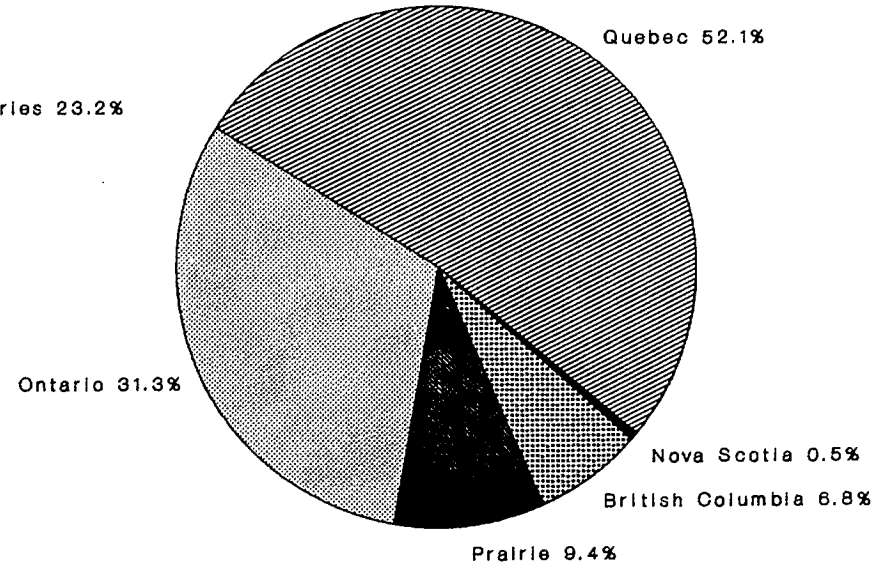

Total Frequency

includes direct, indirect and incidental investment

FRANCE - CANADA 1985-1990 COMPARISON BETWEEN PROVINCES

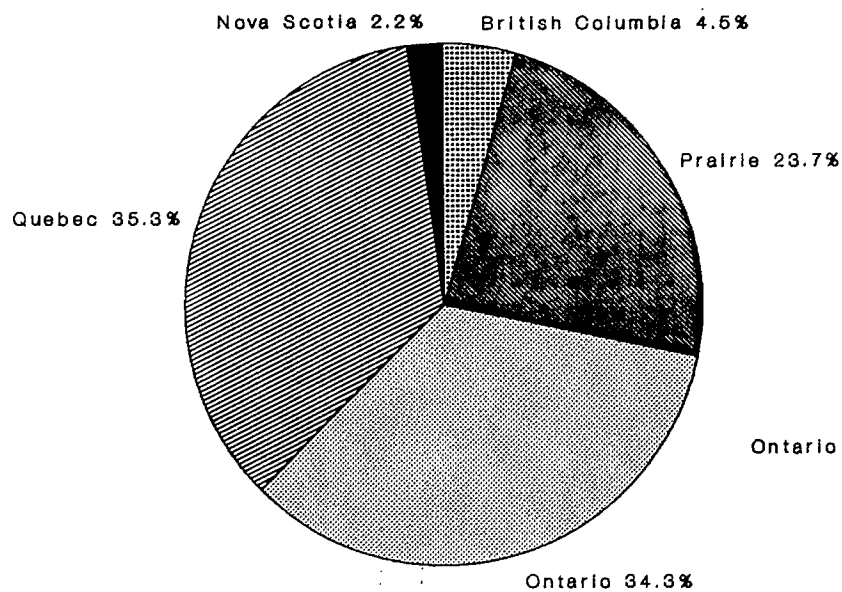

Total Asset Value

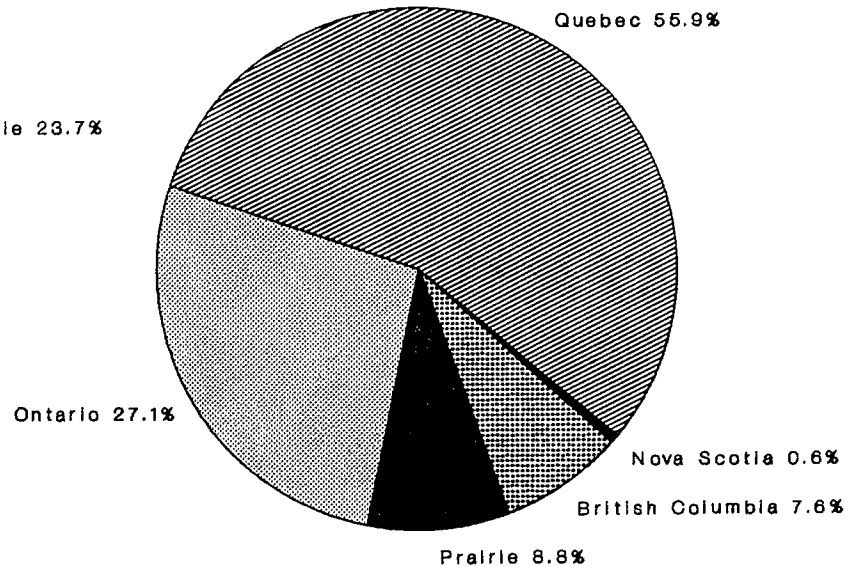

Total Frequency

direct investment only

FRANCE - CANADA 1985-1990

TYPES OF INVESTMENT

TOTAL ASSETS

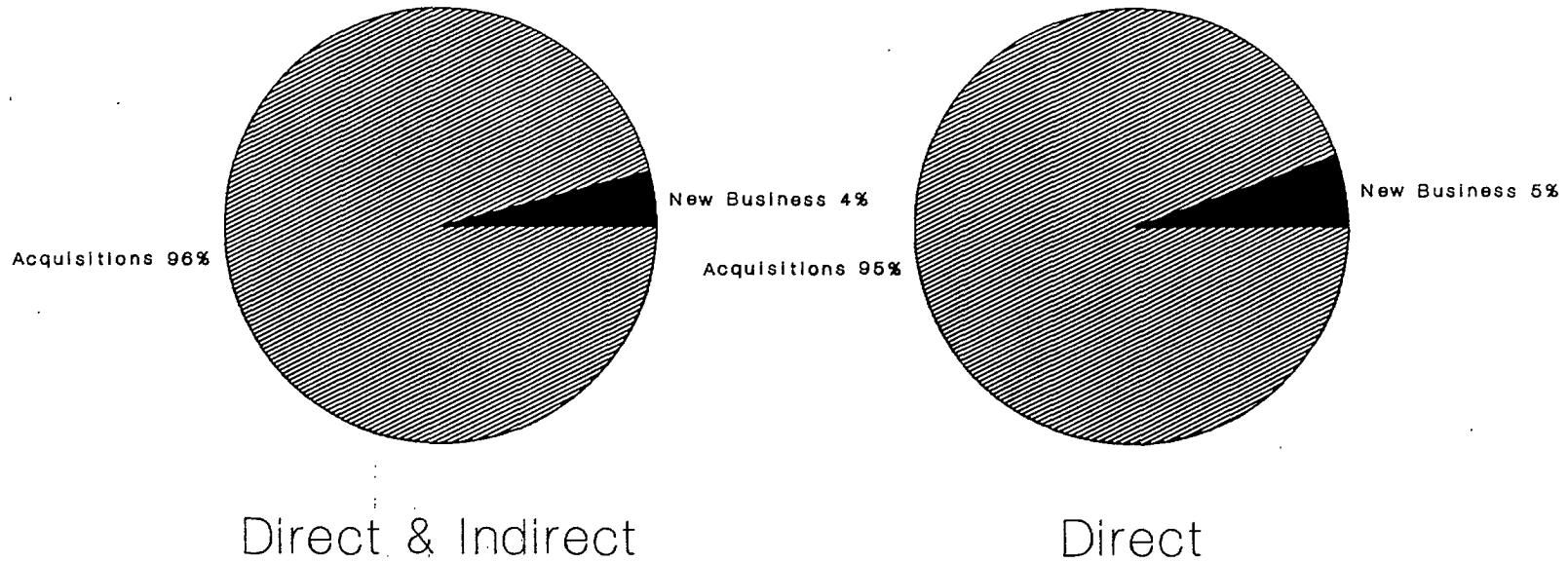

Direct investment comprises 82% of total investment in asset values.

FRANCE - CANADA 1985-1990

TYPES OF INVESTMENT

TOTAL FREQUENCIES

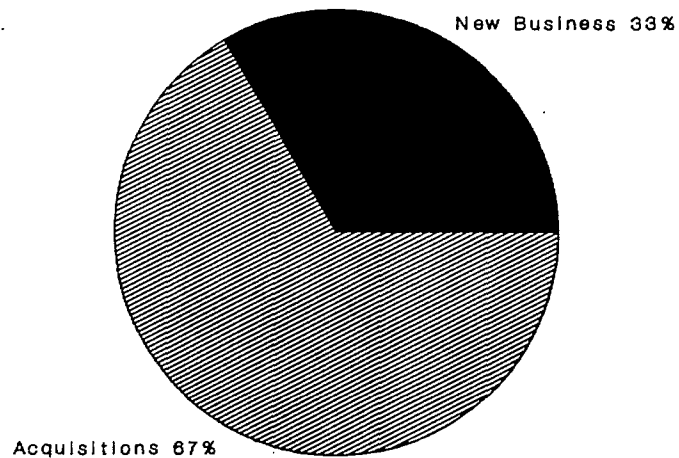

Direct & Indirect

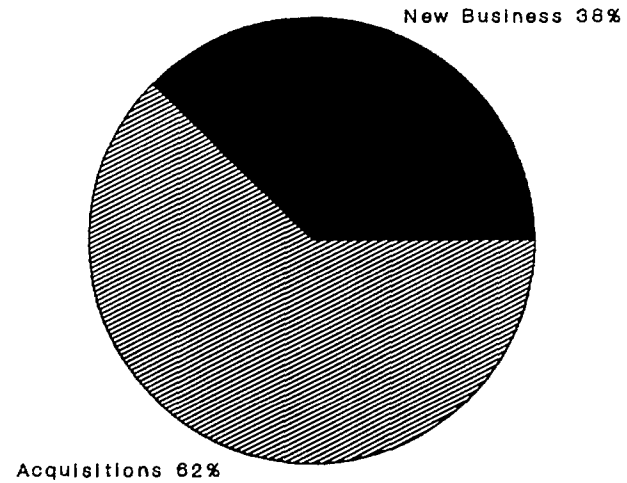

Direct

Direct investment comprises 89% of the total frequency of investment.

FRANCE - CANADA 1985-1990

INDUSTRY SECTORS

TOTAL ASSETS

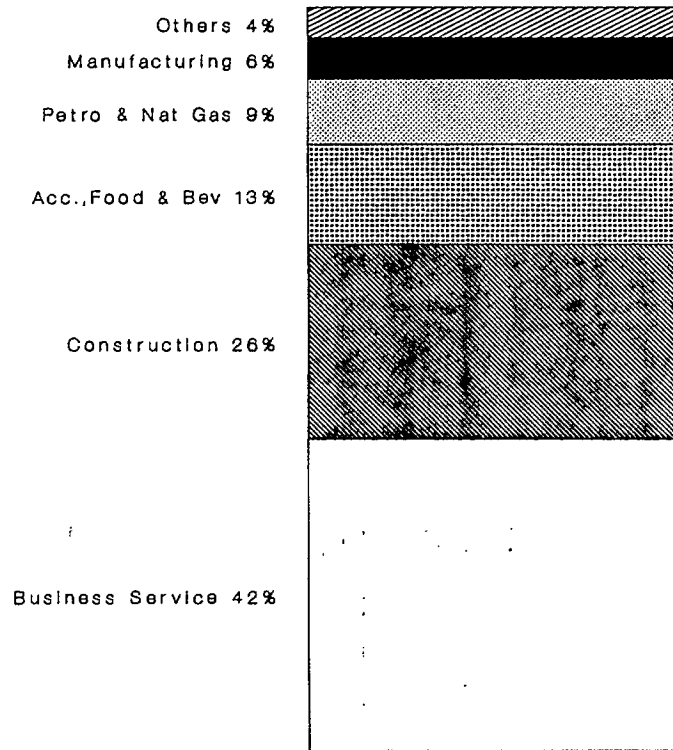

New Business

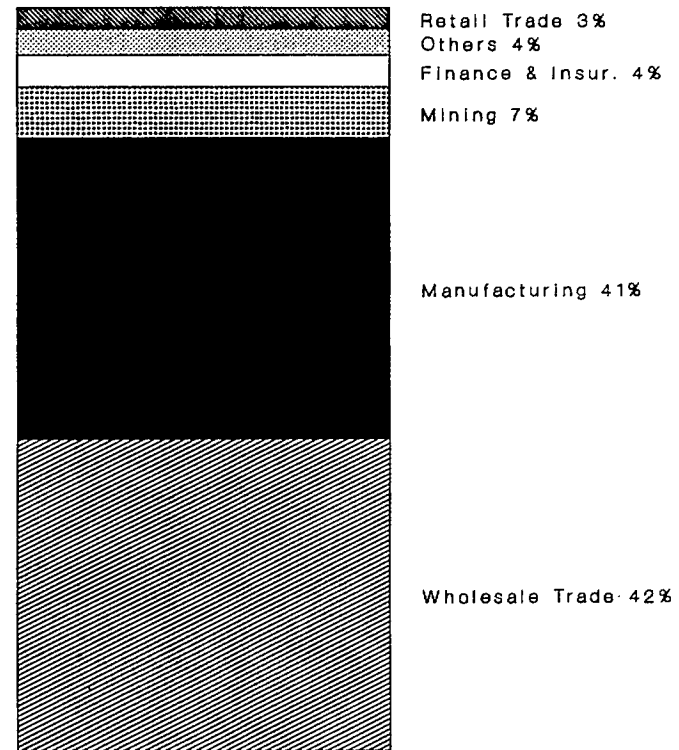

Acquisitions

includes direct, indirect and incidental investment

FRANCE - CANADA 1985-1990

INDUSTRY SECTORS

TOTAL FREQUENCIES

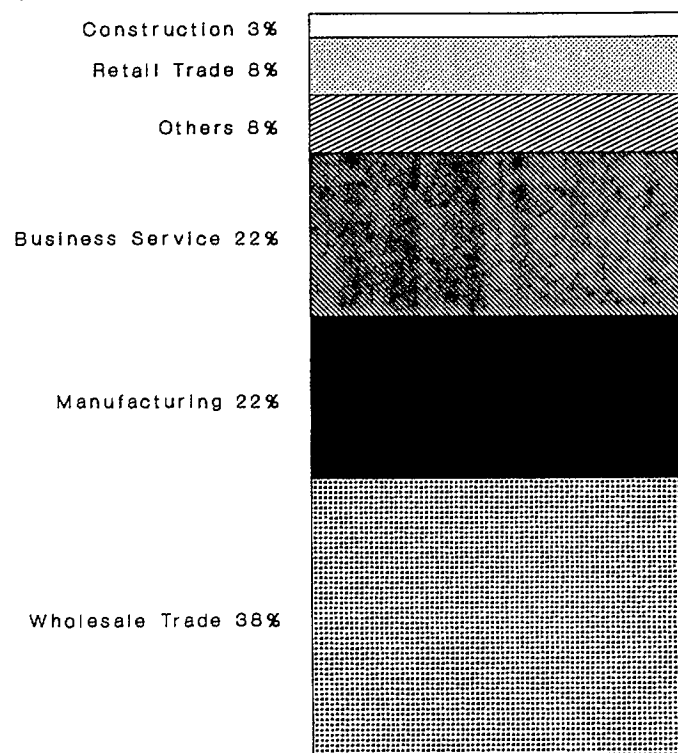

New Business

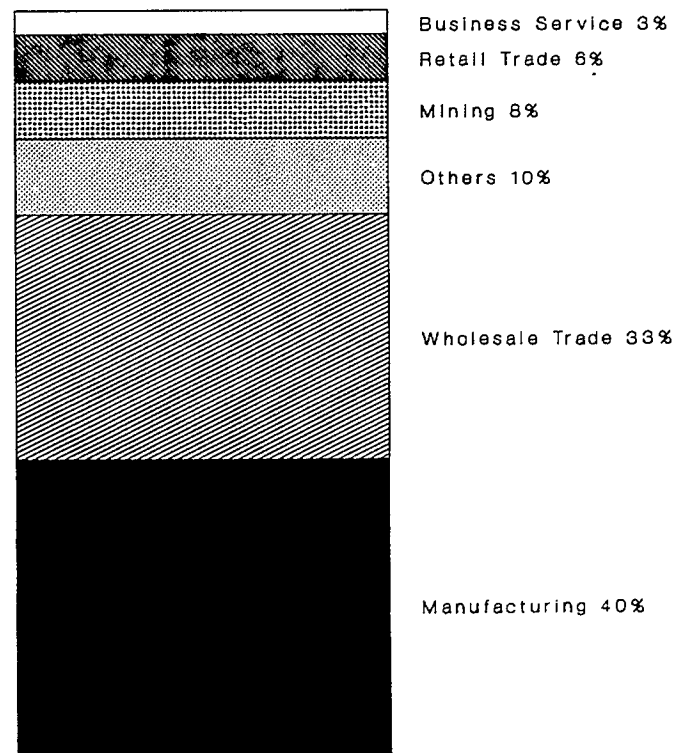

Acquisitions

includes direct, indirect and incidental investment

FRANCE - CANADA 1985-1990

INDUSTRY SECTORS

TOTAL ASSETS

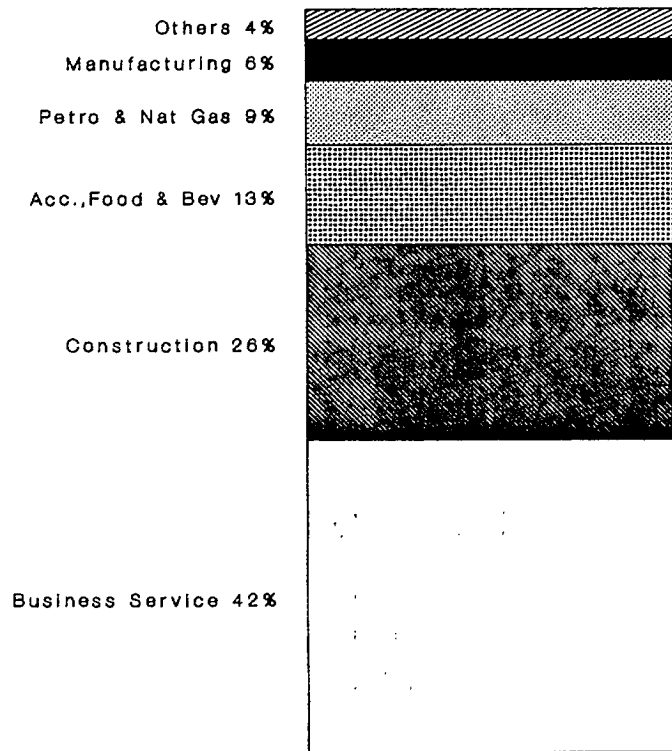

New Business
direct investment only

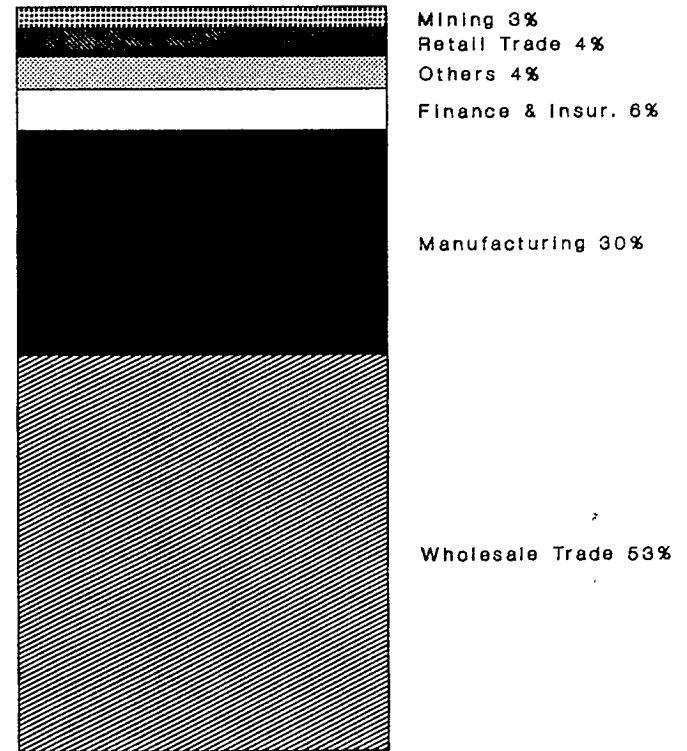

Acquisitions

FRANCE - CANADA 1985-1990

INDUSTRY SECTORS

TOTAL FREQUENCIES

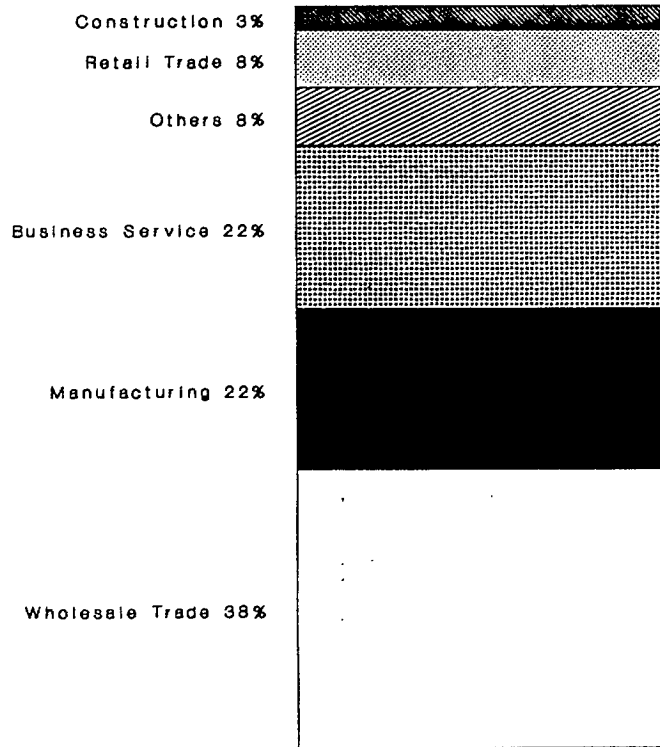

New Business
direct investment only

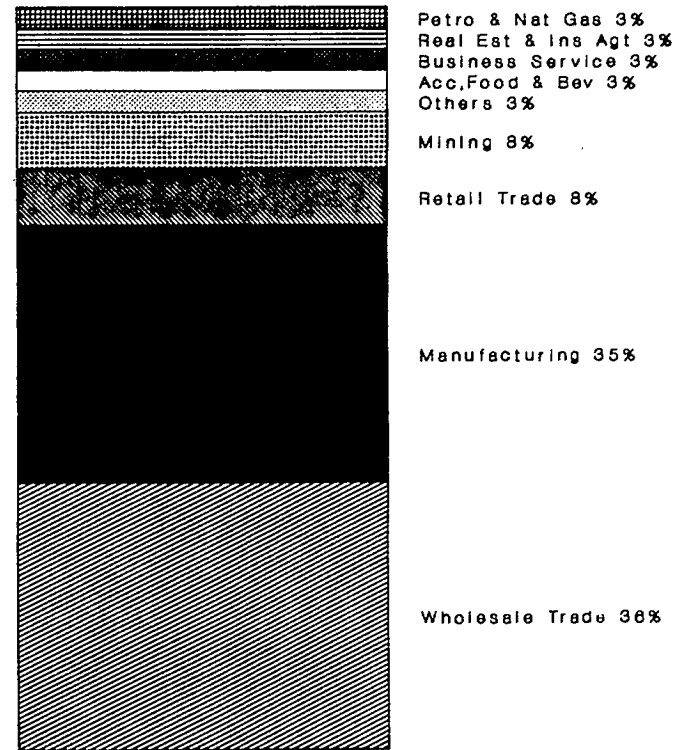

Acquisitions

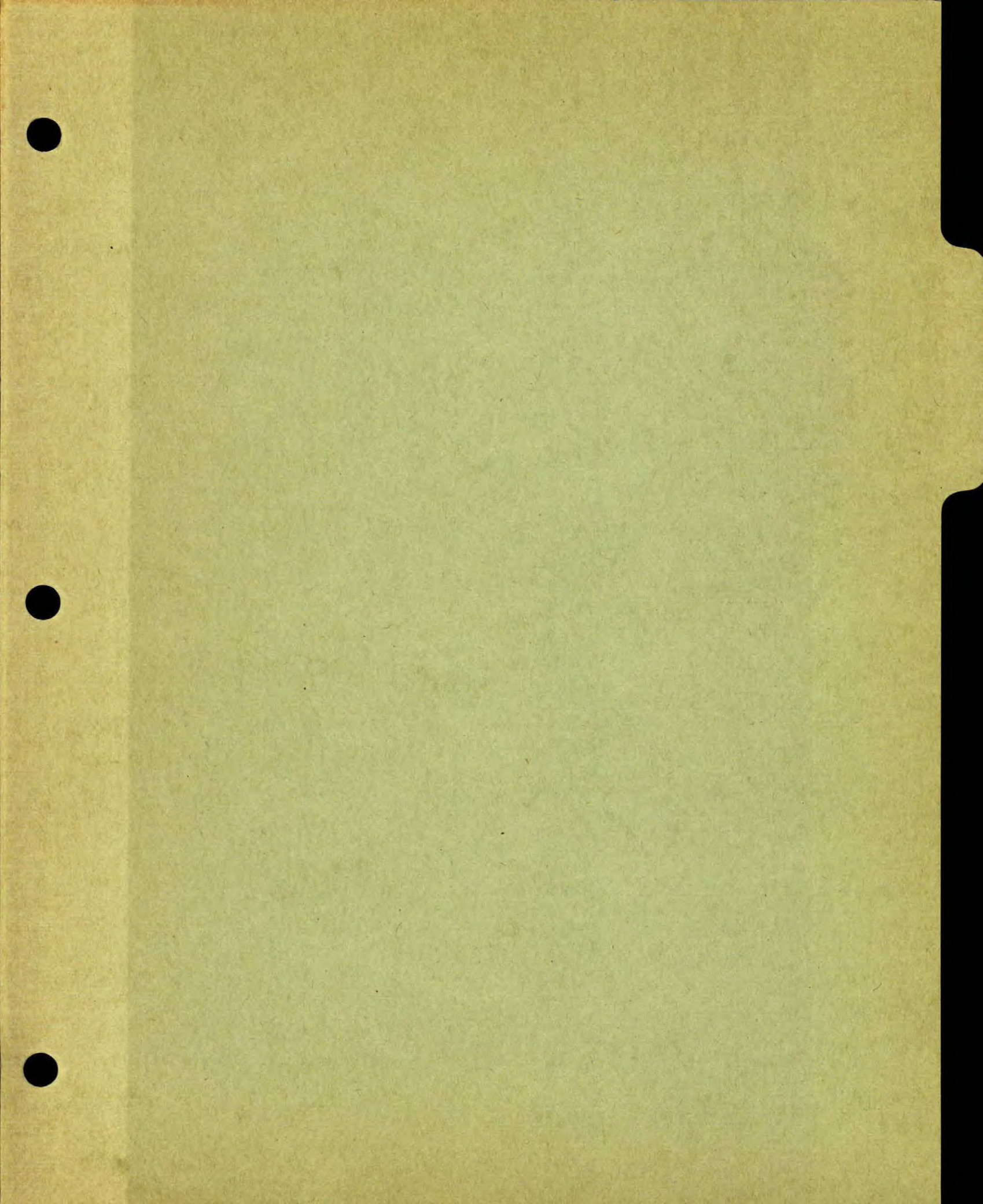

FRANCE - NOVA SCOTIA - AN OVERVIEW

OVERVIEW

A new business in the business service sector was the only French investment targeted to Nova Scotia and also, to all of the Atlantic provinces. This new business was to be engaged in consulting engineering.

FRANCE - NOVA SCOTIA 1985-1990 OVERVIEW TOTAL ASSETS

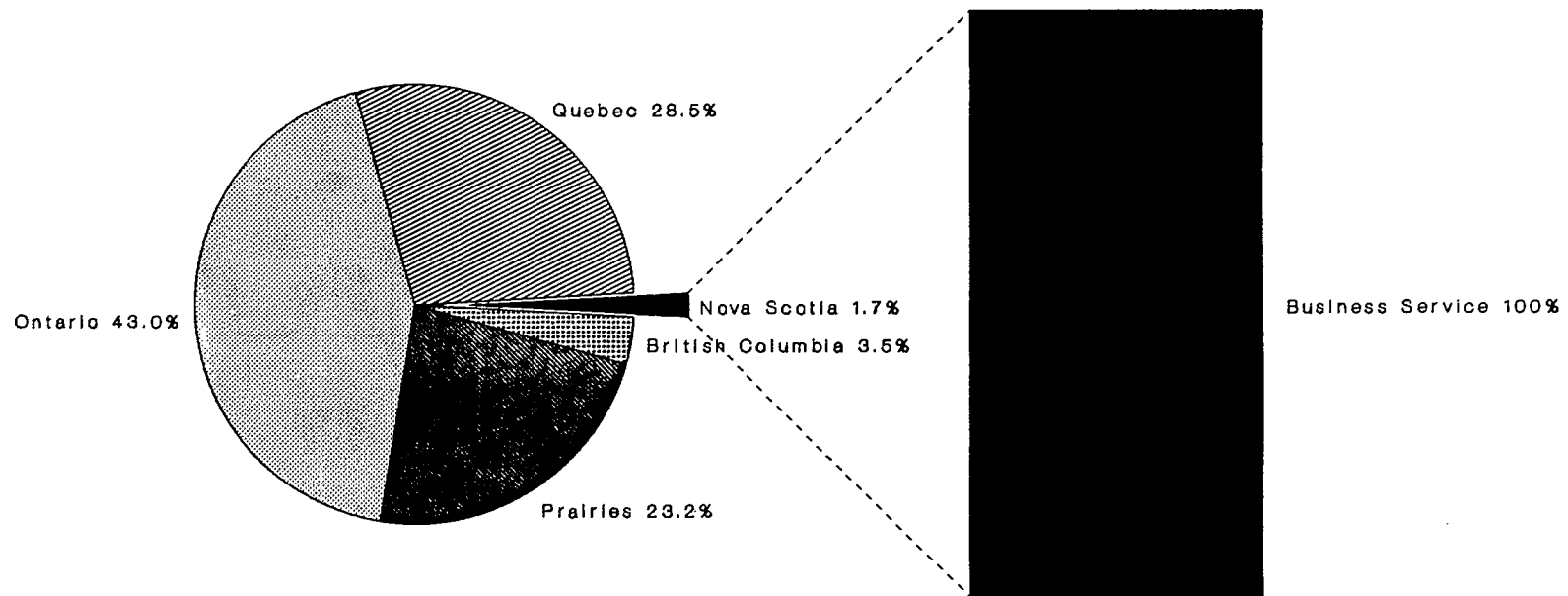

Comparison with Rest of Canada

Industrial Sectors

One investment was made in the Atlantic provinces. It was a new business in the Nova Scotia, business services sector.

FRANCE - NOVA SCOTIA 1985-1990 OVERVIEW TOTAL FREQUENCIES

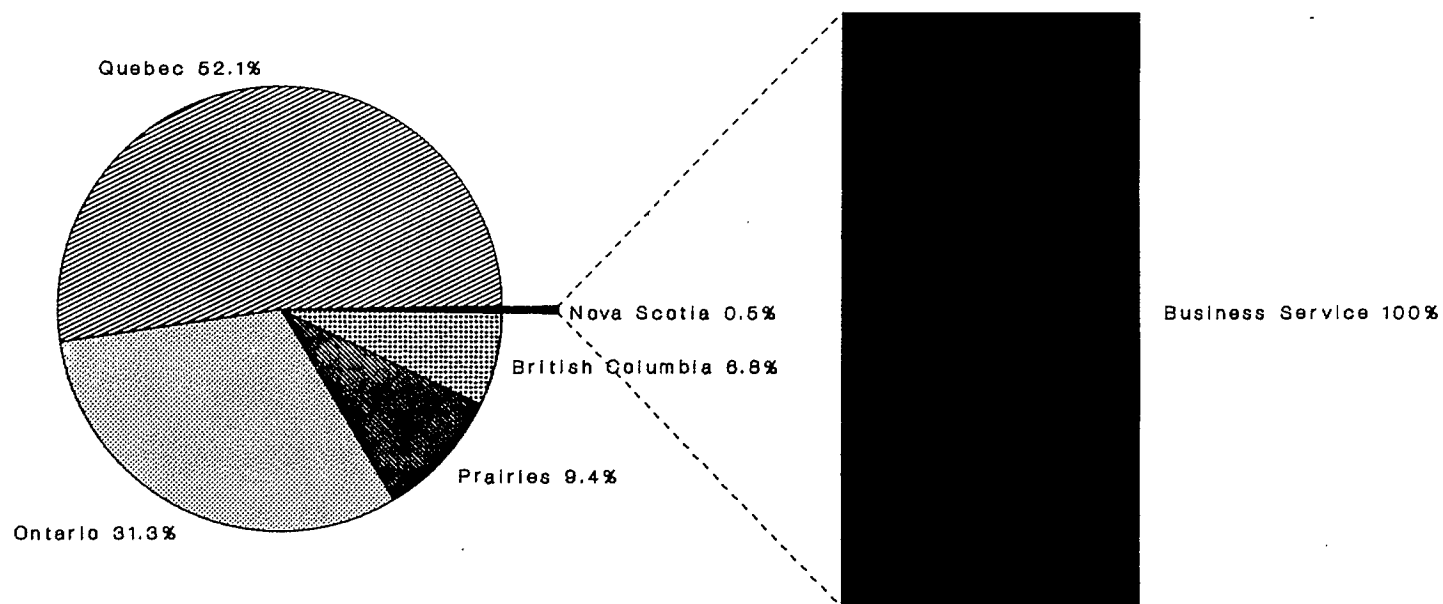

Comparison with Rest of Canada

Industrial Sectors

One investment was made in the Atlantic provinces. It was a new business in the Nova Scotia, business services sector.

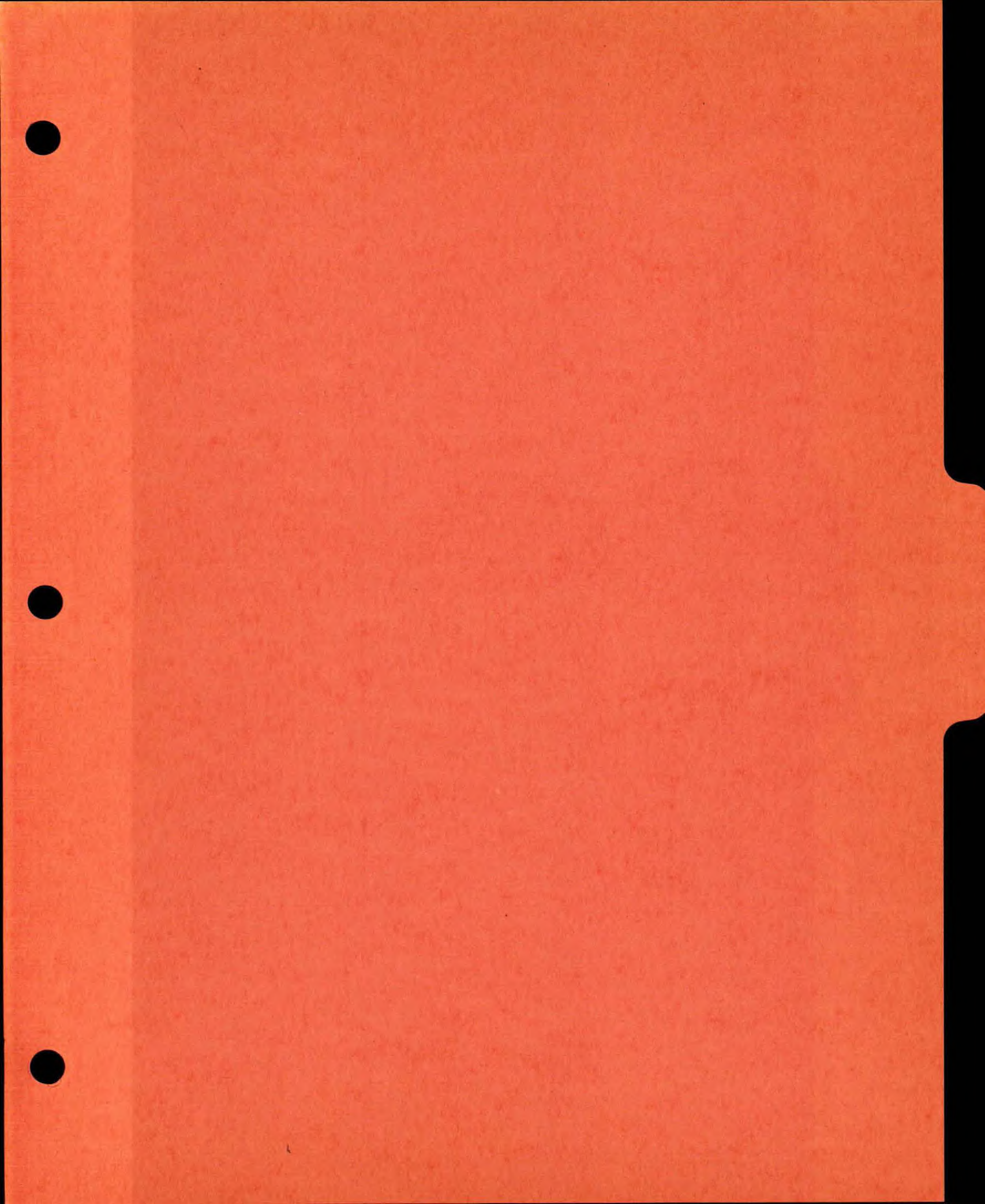

FRANCE - QUEBEC - AN OVERVIEW

France directs to Quebec, 29% of the total asset value and 52% of the total frequency, of its investment to Canada. Quebec is the most frequent target of French investment.

TYPES OF INVESTMENT

96% of the asset value and 95% of the total frequency of French investment to Quebec is direct. Of this direct investment, only 5% of the asset value of investment while 54% of the frequency of transactions are placed in new business. Usually high frequencies and low asset value of transactions in the manufacturing, wholesale trade, and business services causes the discrepancy. Quebec was an especially popular place for French investors to initiate new businesses, accounting for 80% of the total frequency of French new businesses in Canada.

INDUSTRY SECTORS

Wholesale trade is the dominant target for French investors, with 60% of the total asset value and 40% of the total frequency of investment. Manufacturing follows with 23% of the asset value and 26% of the total frequency. In terms of the asset value of investment, retail trade (9%) is also significant. After manufacturing, business service (15%) and retail trade (9%) are the next most frequent industry targets.

FRANCE - QUEBEC 1985-1990 OVERVIEW TOTAL ASSETS

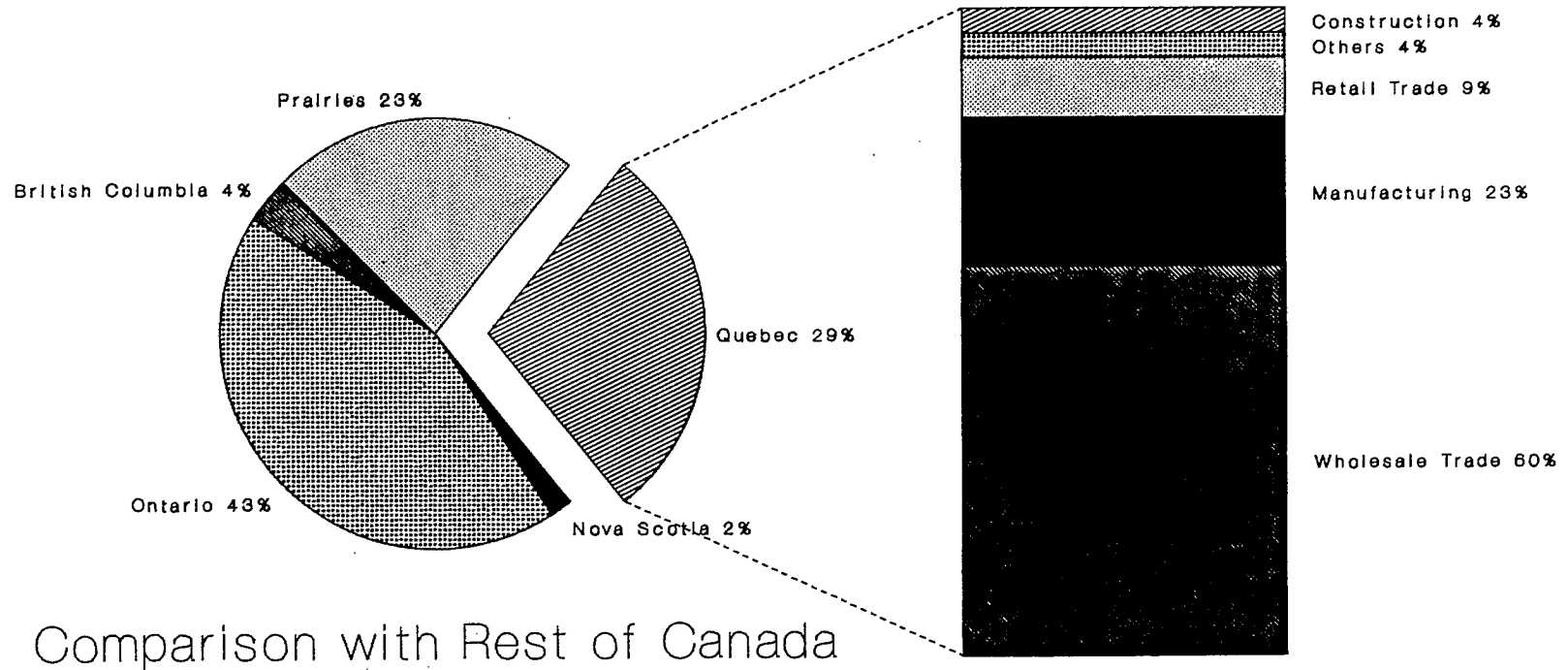

includes direct, indirect and incidental investment

FRANCE - QUEBEC 1985-1990 OVERVIEW TOTAL FREQUENCIES

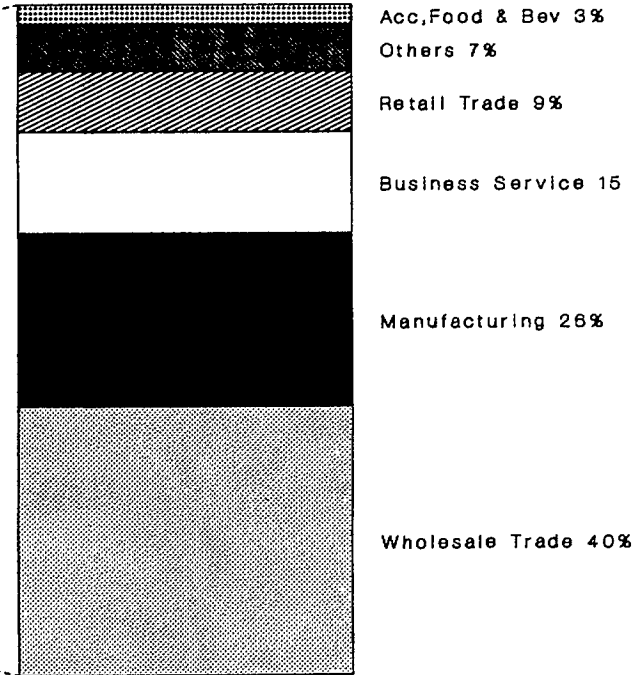
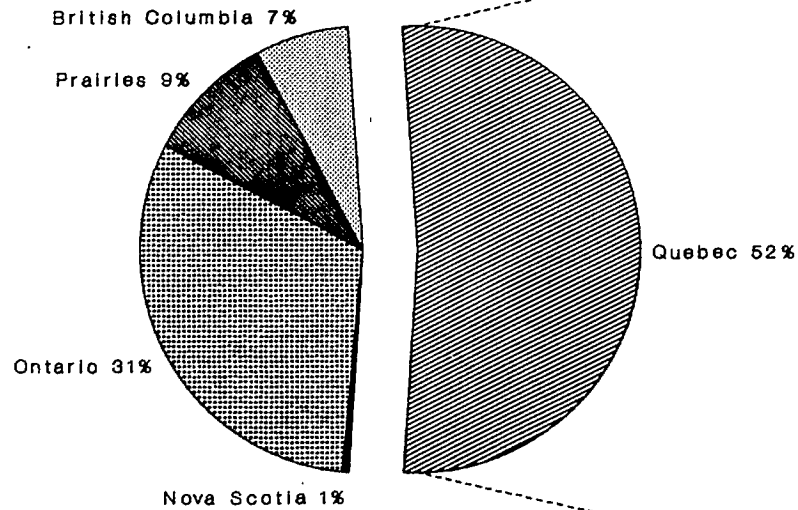

Comparison with Rest of Canada

Industrial Sectors

direct, indirect and incidental
investment

FRANCE - QUEBEC 1985-1990 OVERVIEW TOTAL ASSETS

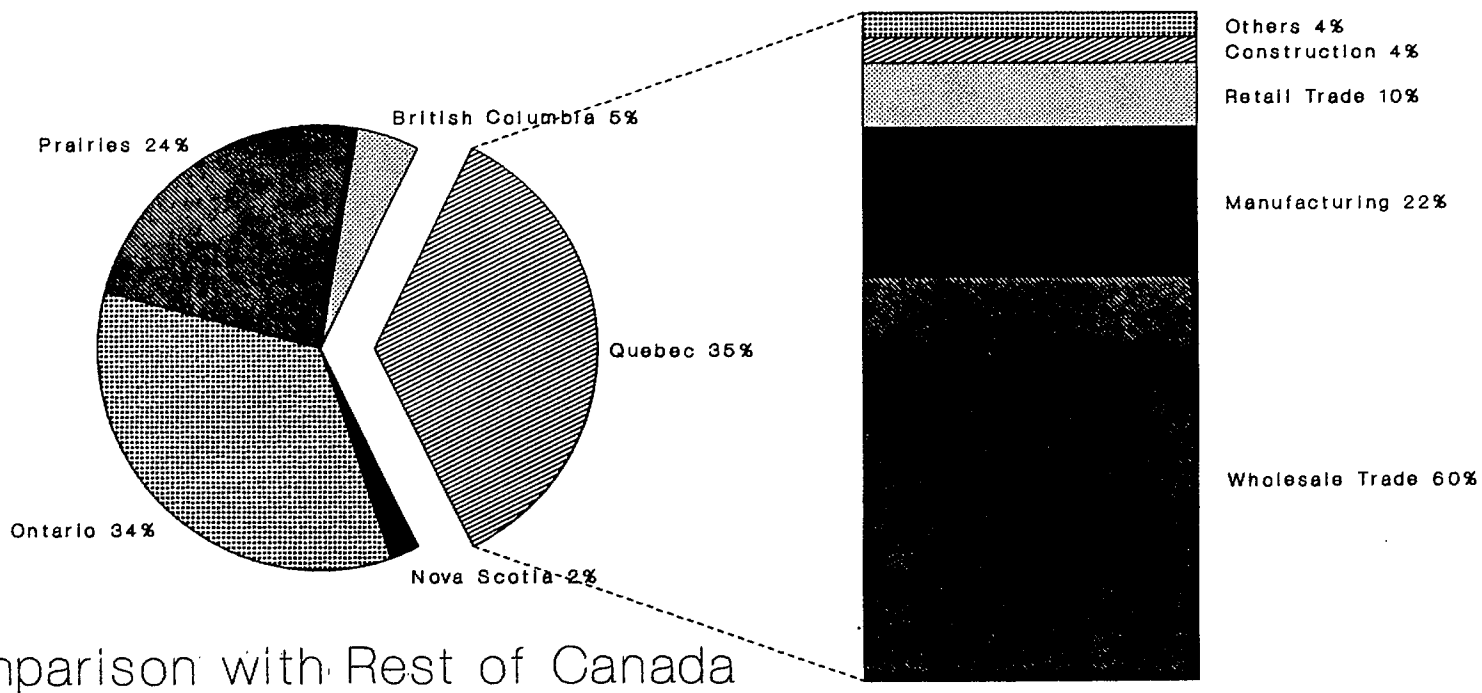

Comparison with Rest of Canada

Industrial Sectors

direct investment only

FRANCE - QUEBEC 1985-1990 OVERVIEW TOTAL FREQUENCIES

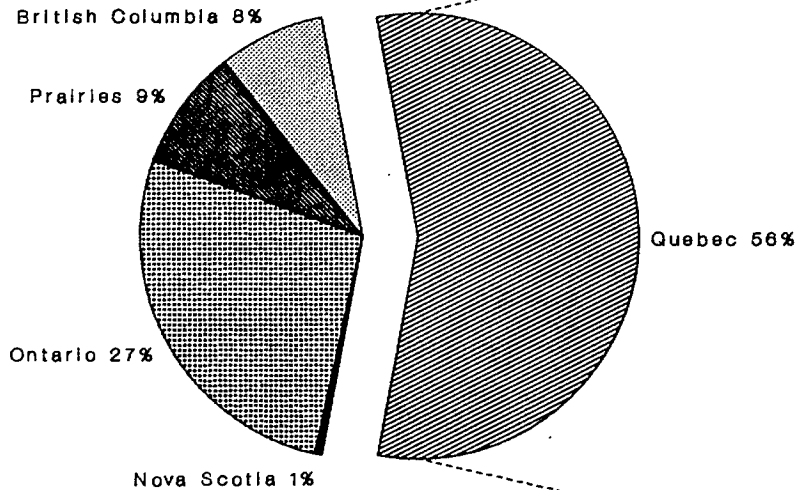

Comparison with Rest of Canada

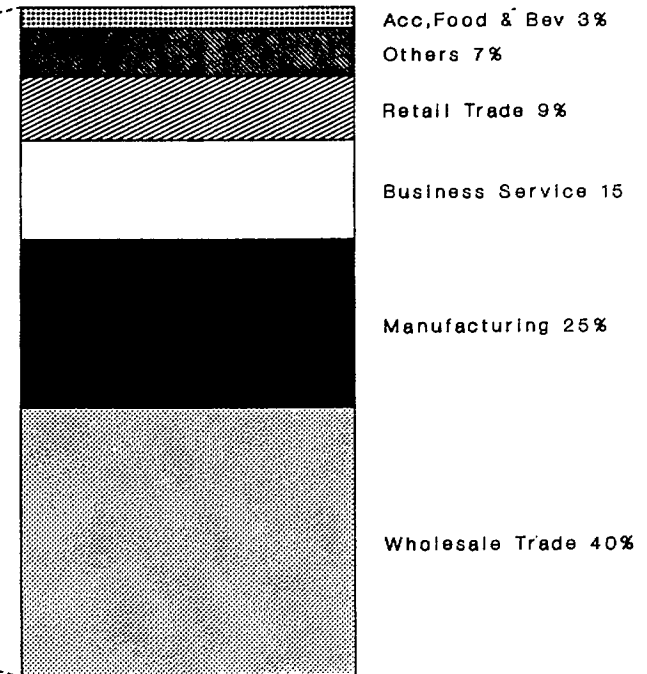

Industrial Sectors

direct investment only

FRANCE - QUEBEC 1985-1990

TYPES OF INVESTMENT

TOTAL ASSETS

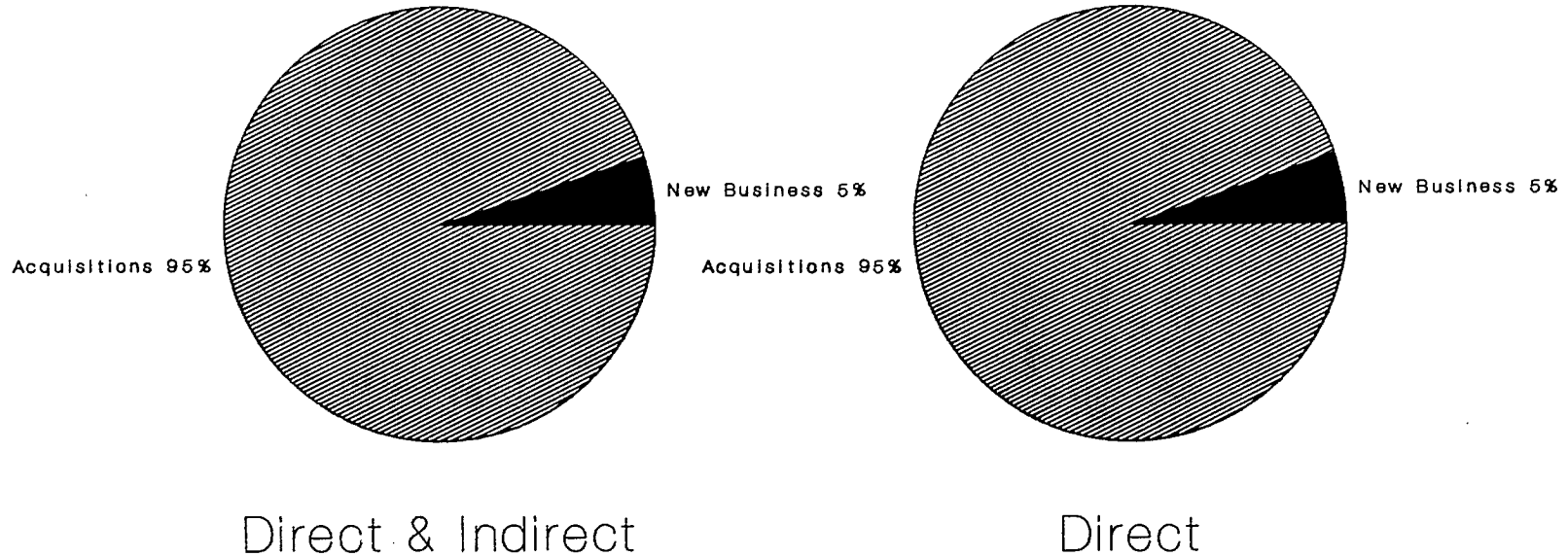

Direct investment comprises 96% of total investment in asset values.

FRANCE - QUEBEC 1985-1990

TYPES OF INVESTMENT

TOTAL FREQUENCIES

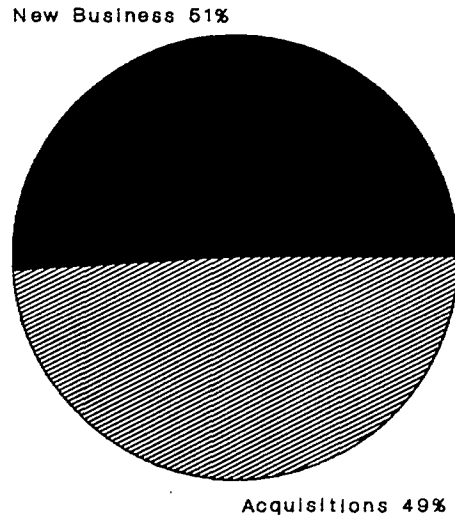

Direct & Indirect

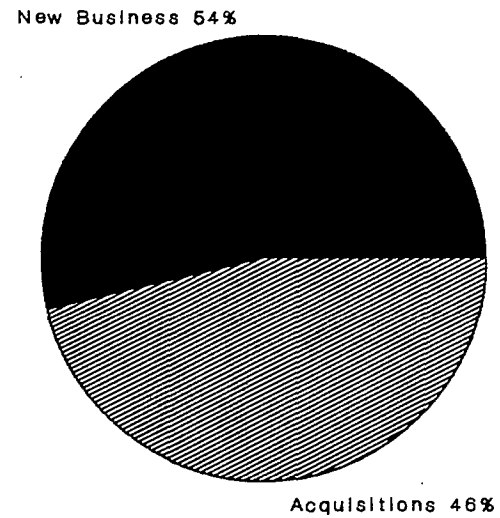

Direct

Direct investment comprises 95% of total investment in asset values.

FRANCE - QUEBEC 1985-1990

INDUSTRY SECTORS

TOTAL ASSETS

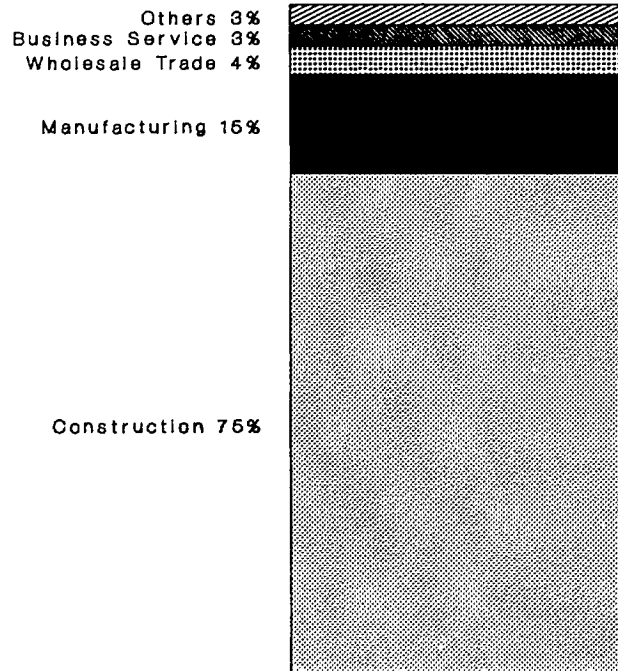

New Business

includes direct, indirect and incidental investment

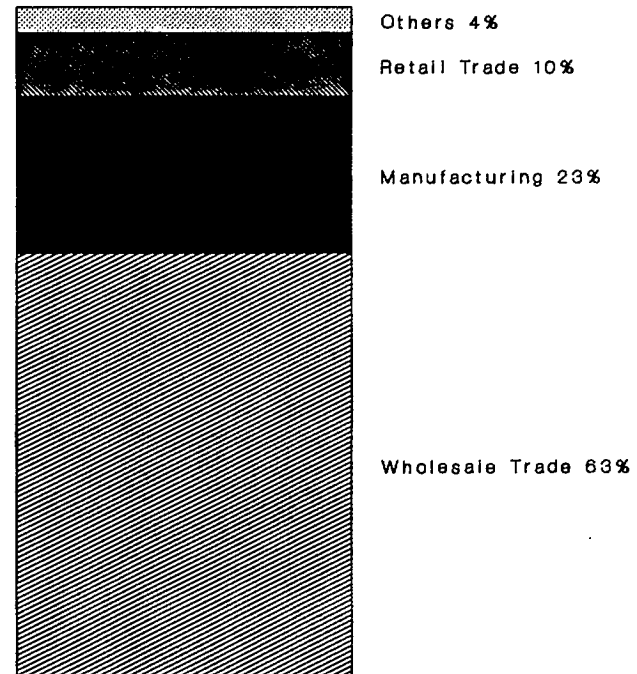

Acquisitions

FRANCE - QUEBEC 1985-1990

INDUSTRY SECTORS

TOTAL FREQUENCIES

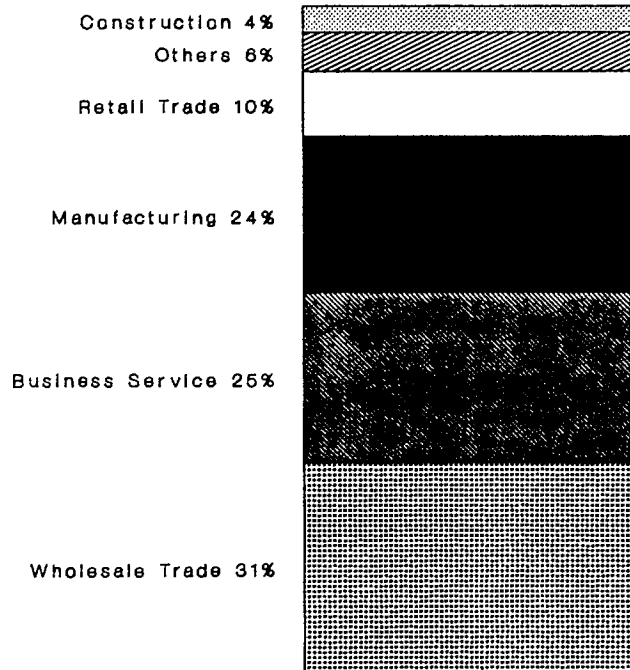

New Business

includes direct, indirect and incidental investment

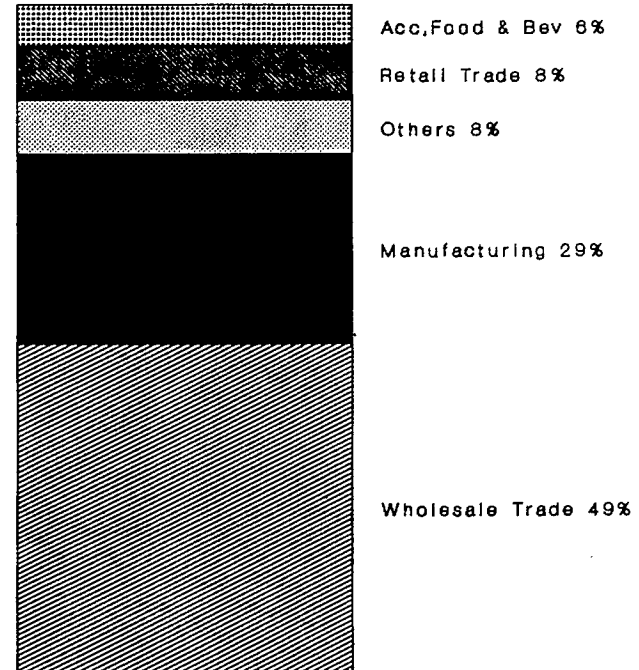

Acquisitions

FRANCE - QUEBEC 1985-1990

INDUSTRY SECTORS

TOTAL ASSETS

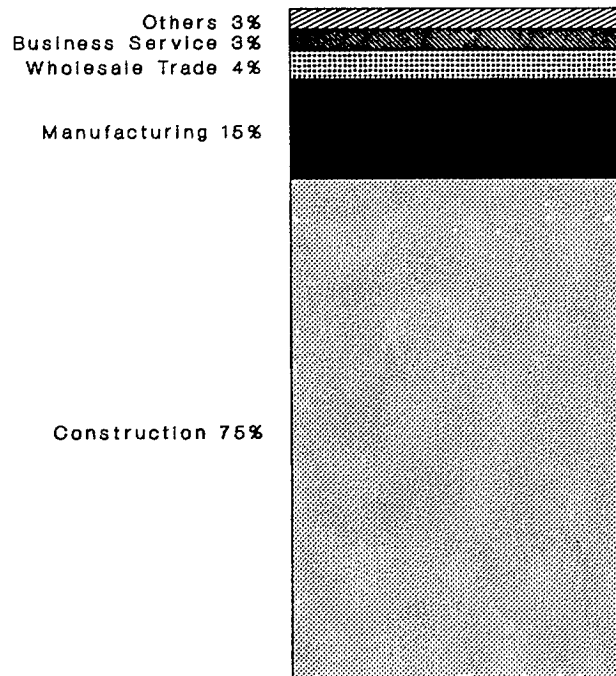

New Business

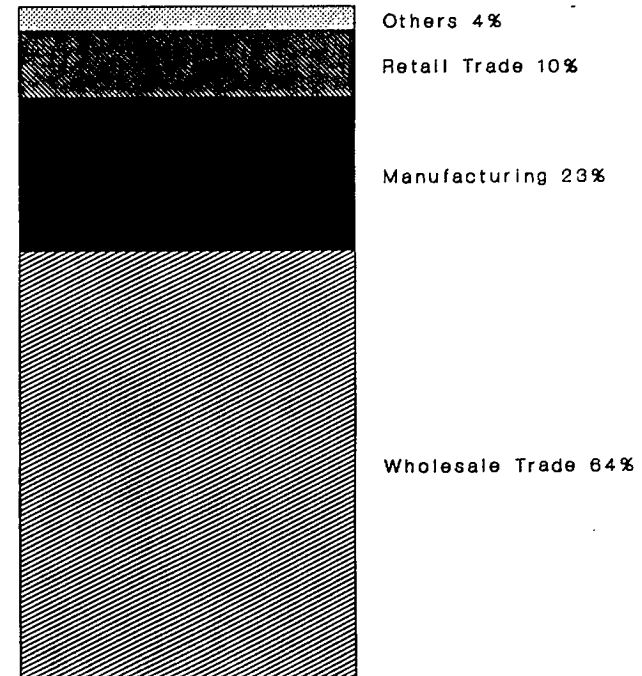

Acquisitions

direct investment only

FRANCE - QUEBEC 1985-1990

INDUSTRY SECTORS

TOTAL FREQUENCIES

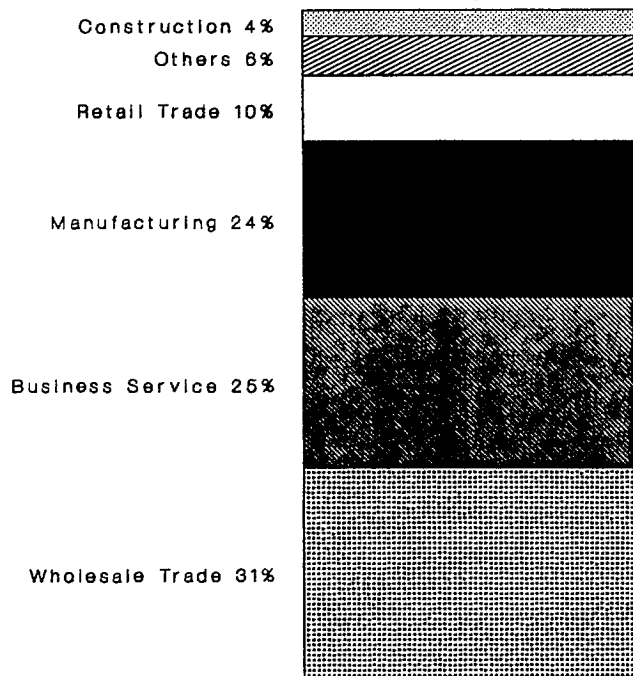

New Business

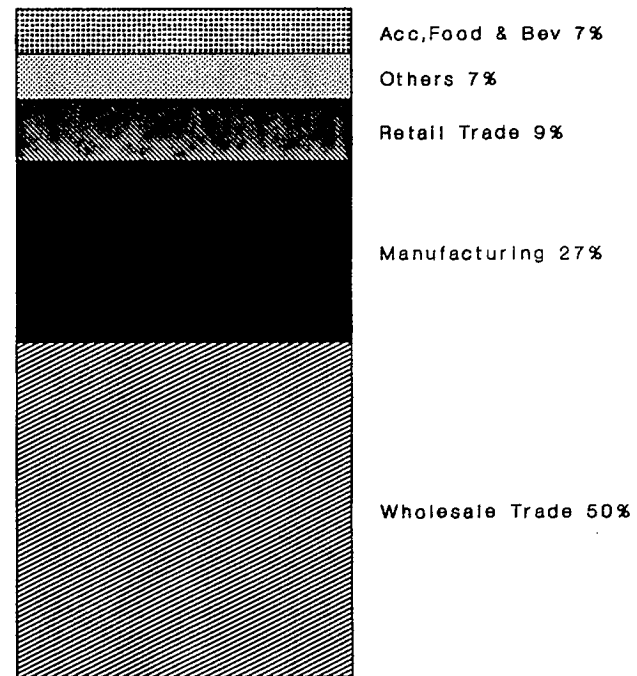

Acquisitions

direct investment only



FRANCE - ONTARIO - AN OVERVIEW

OVERVIEW

Ontario is a primary destination of French investment receiving, 43% of the total asset value and 31% of the total frequency of investment to Canada.

TYPES OF INVESTMENT

62% of the asset value and 77% of the total frequency of investment made in Ontario is direct. New business accounts for only 2% of the asset value and 24% of the frequency of this direct investment.

New businesses initiated in the manufacturing sector, in contrast, with acquisitions made in the same sector, were infrequent and low in asset value.

INDUSTRY SECTORS

Manufacturing is the most attractive industry sector in Ontario for French investors, with 75% of total asset value (75%) and 47% of the total frequency. Wholesale trade (12%) and finance and insurance (10%) also drew a significant portion of the asset value of investment to Ontario. After manufacturing, wholesale trade (33%) was the next most frequented industry sector followed by mining (7%) and retail trade (5%).

FRANCE - ONTARIO 1985-1990 OVERVIEW TOTAL ASSETS

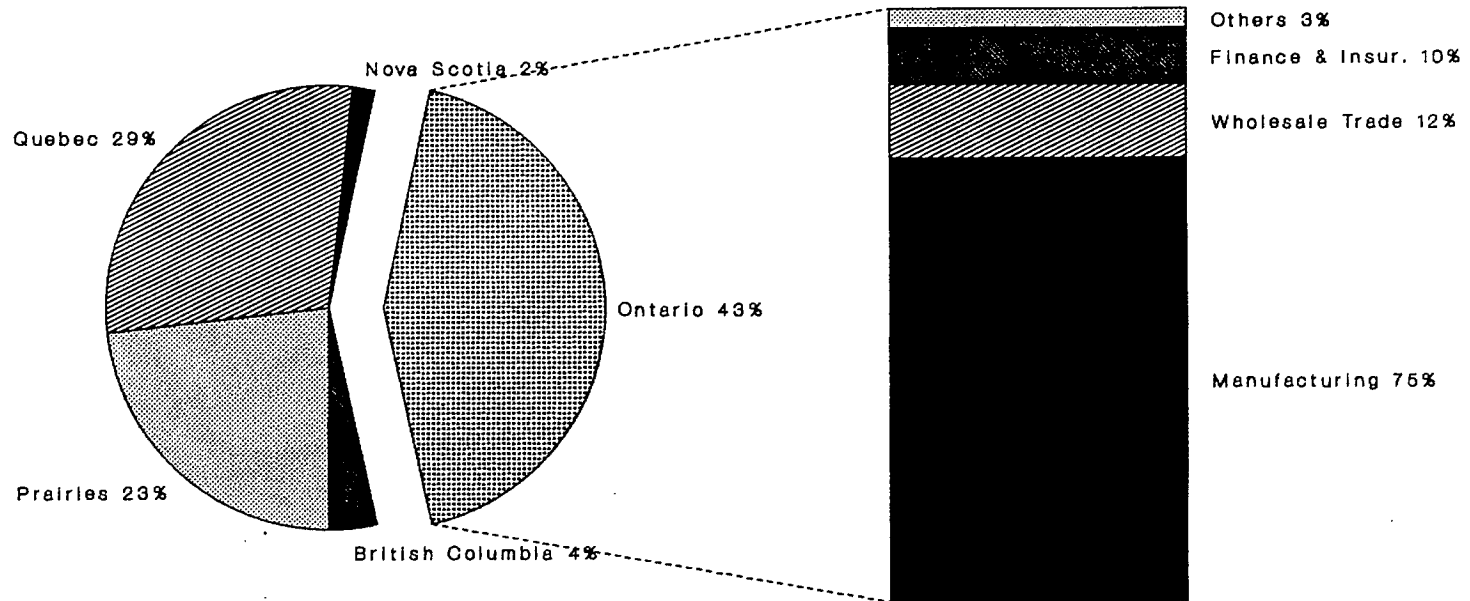

Comparison with Rest of Canada

Industrial Sectors

includes direct, indirect and incidental investment

FRANCE - ONTARIO 1985-1990 OVERVIEW TOTAL FREQUENCIES

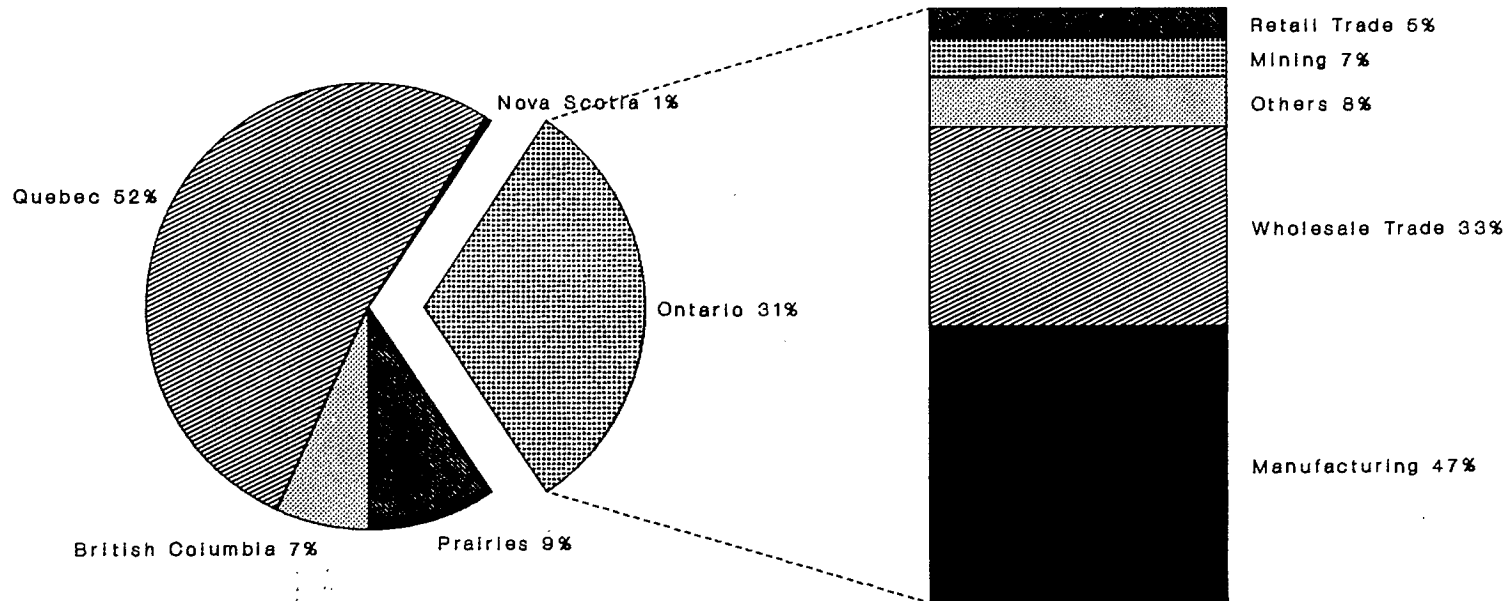

Comparison with Rest of Canada

Industrial Sectors

includes direct, indirect and incidental investment

FRANCE - ONTARIO 1985-1990 OVERVIEW TOTAL ASSETS

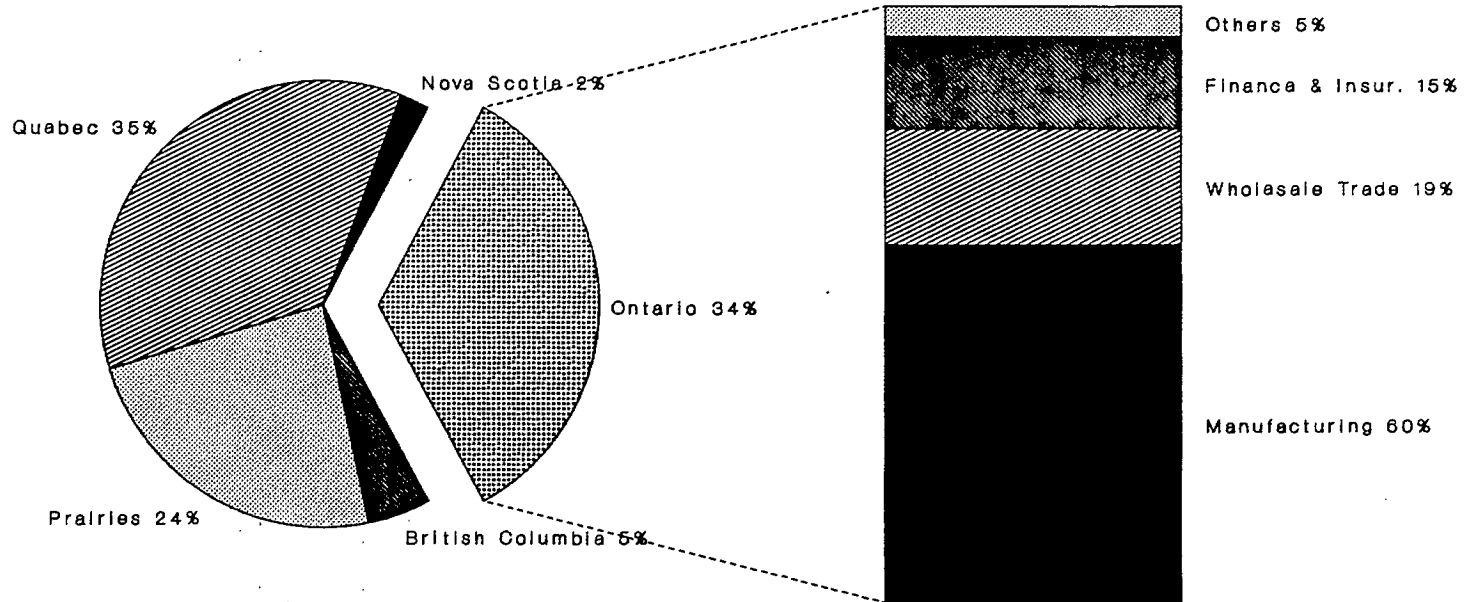

Comparison with Rest of Canada

Industrial Sectors

direct investment only

FRANCE - ONTARIO 1985-1990 OVERVIEW TOTAL FREQUENCIES

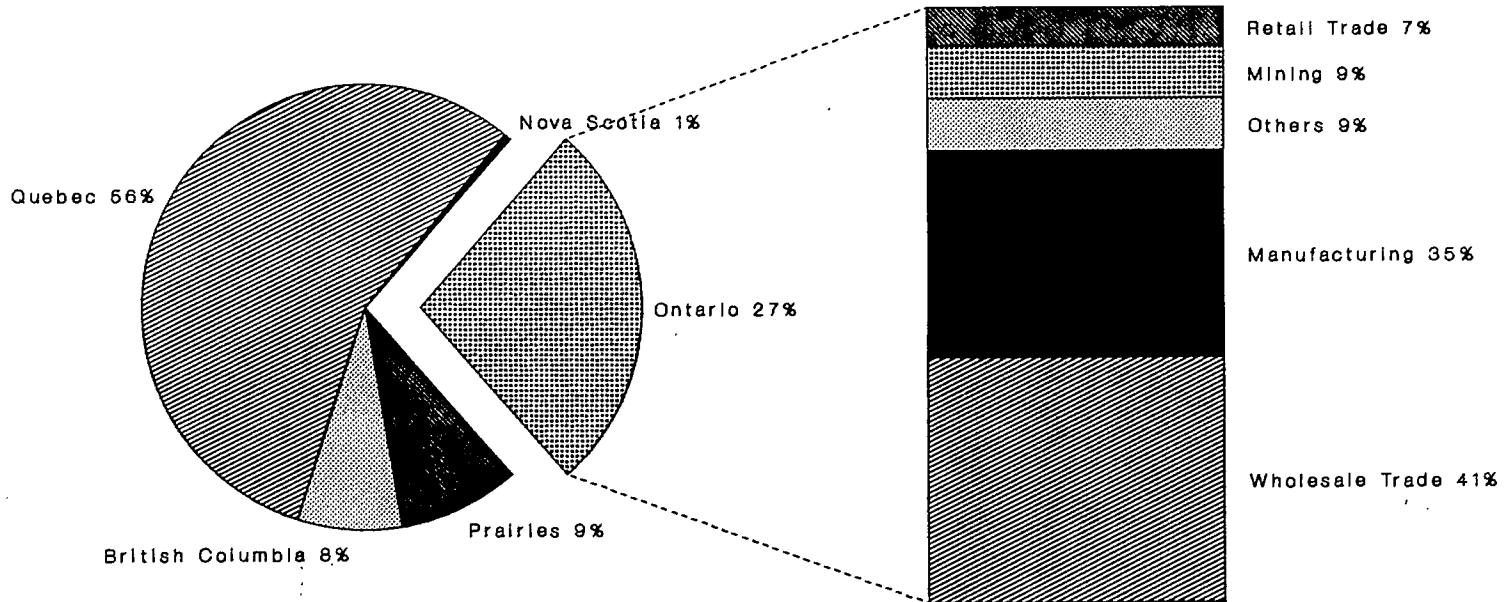

Comparison with Rest of Canada

Industrial Sectors

direct investment only

FRANCE - ONTARIO 1985-1990

TYPES OF INVESTMENT

TOTAL ASSETS

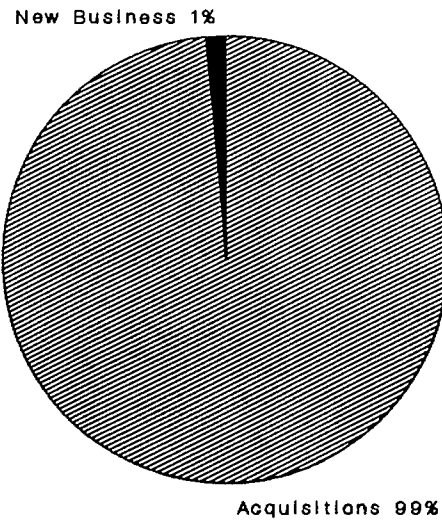

Direct & Indirect

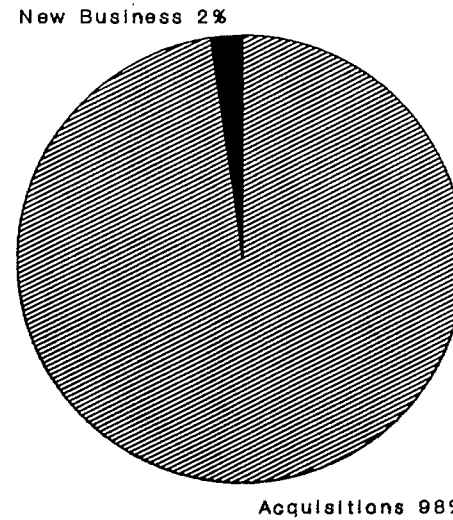

Direct

Direct investment comprises 62% of total investment in asset values.

FRANCE - ONTARIO 1985-1990

TYPES OF INVESTMENT

TOTAL FREQUENCIES

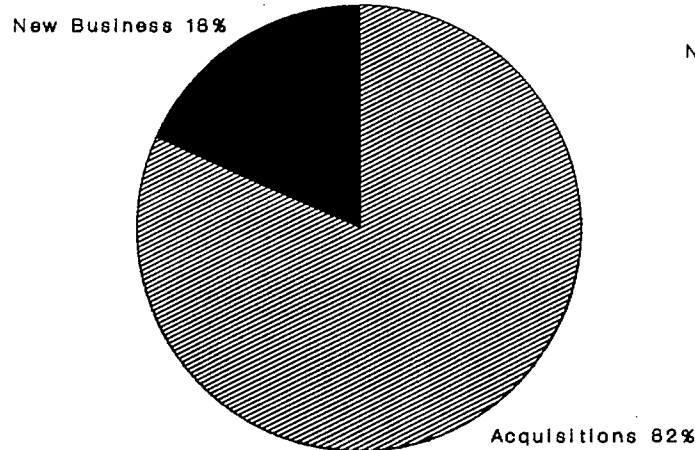

Direct & Indirect

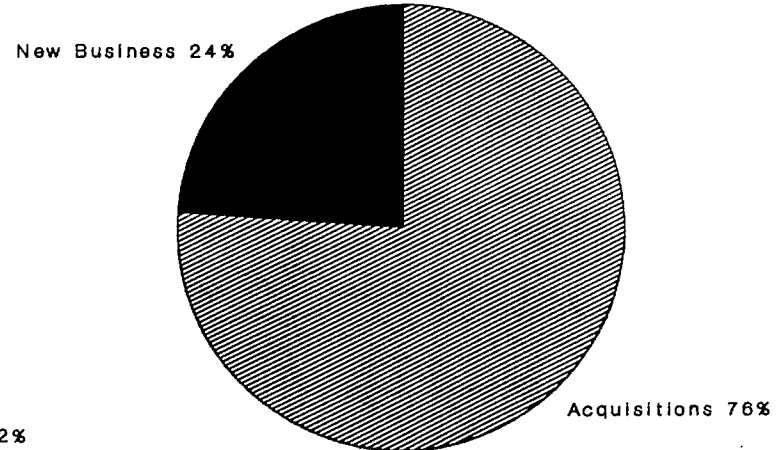

Direct

Direct investment comprises 82% of total investment in asset values.

FRANCE - ONTARIO 1985-1990 INDUSTRY SECTORS TOTAL ASSETS

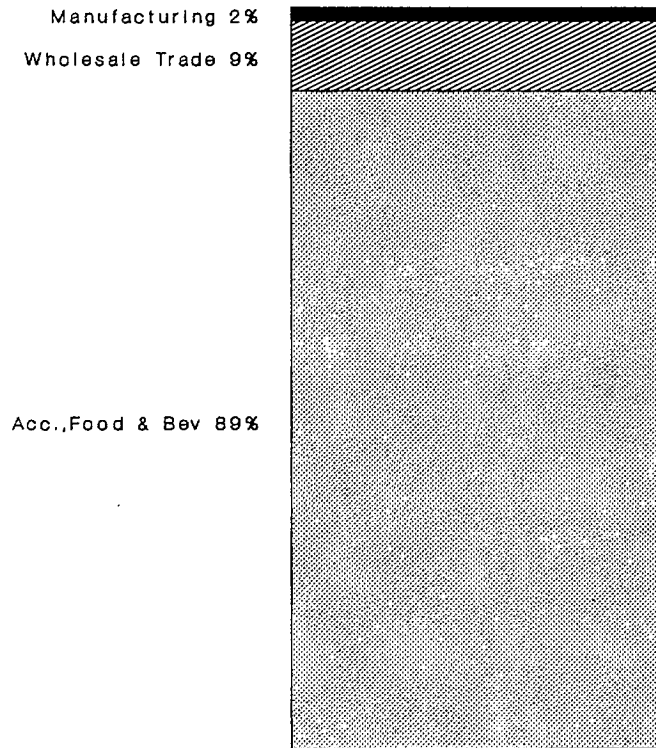

New Business

includes direct, indirect and incidental investment

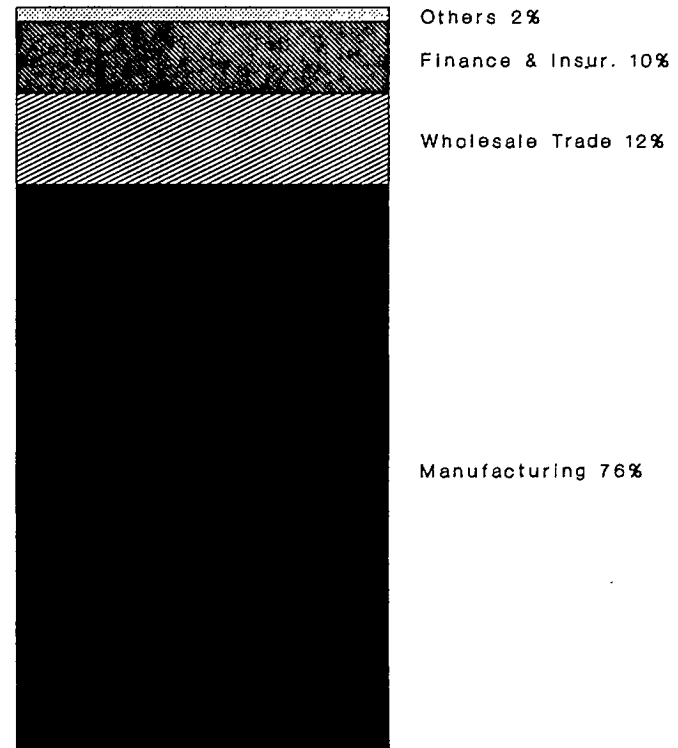

Acquisitions

FRANCE - ONTARIO 1985-1990 INDUSTRY SECTORS TOTAL FREQUENCIES

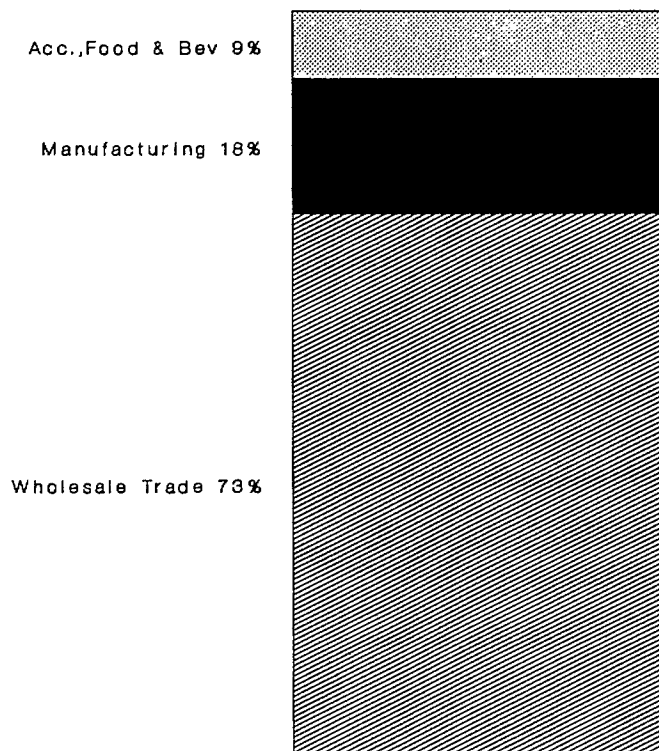

New Business

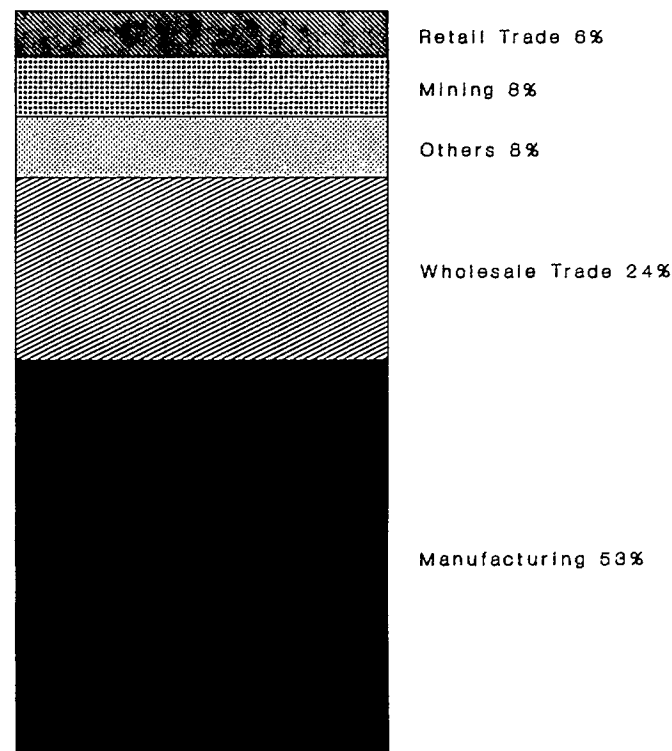

Acquisitions

includes direct, indirect and incidental investment

FRANCE - ONTARIO 1985-1990 INDUSTRY SECTORS TOTAL ASSETS

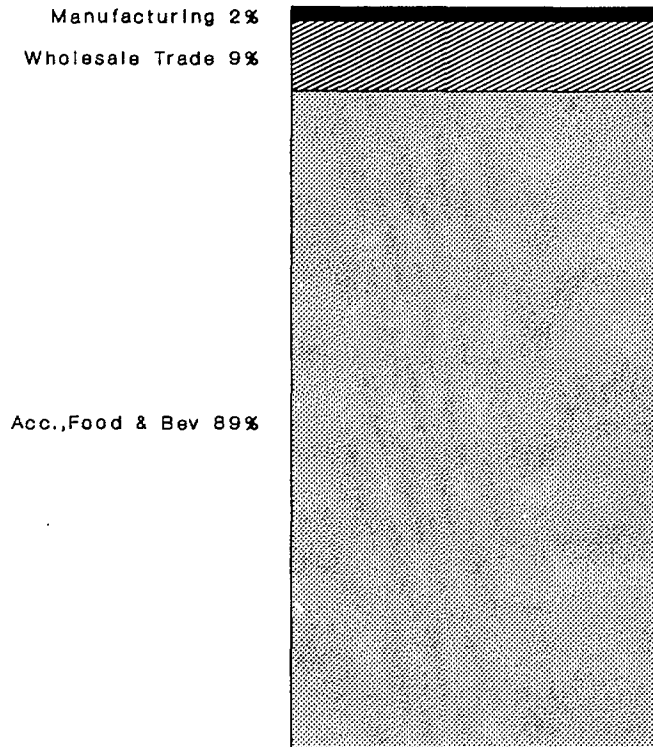

New Business
direct investment only

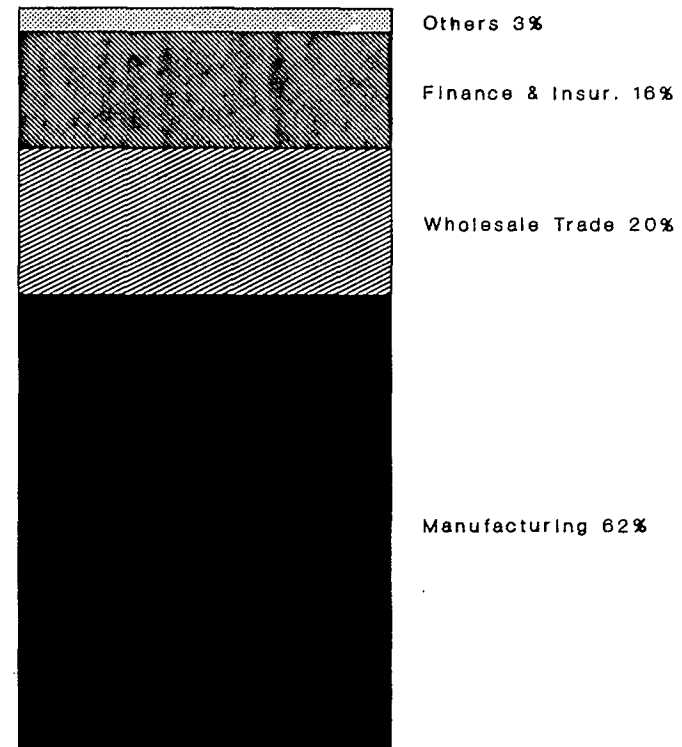

Acquisitions

FRANCE - ONTARIO 1985-1990 INDUSTRY SECTORS TOTAL FREQUENCIES

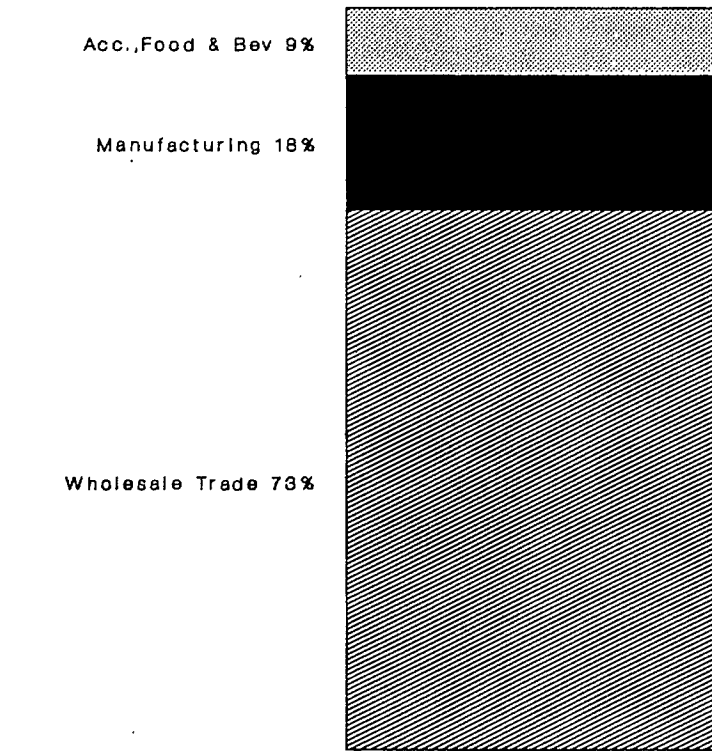

New Business
direct investment only

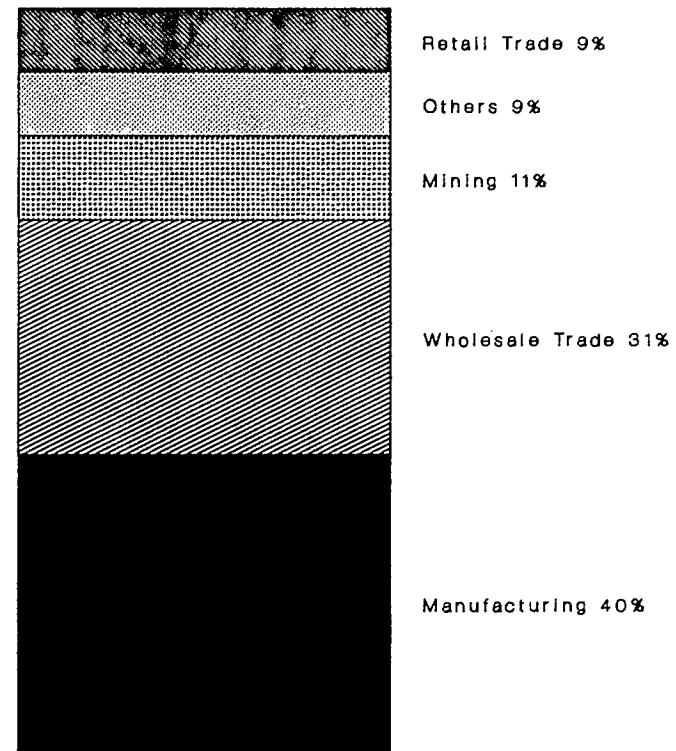

Acquisitions

FRANCE - PRAIRIE PROVINCES - AN OVERVIEW

OVERVIEW

French investment to the Prairie provinces accounts for 23 % of asset value and 9% of the frequency of the total to Canada.

DIVISION BETWEEN PROVINCES

Alberta dominates with 81% of the asset value and 83% of the frequency of French investment to the Prairie provinces. Saskatchewan receives 19% of the asset value of investment to the Prairies, though only one transaction occurred there. Two transactions comprising a negligible amount of investment were targeted to Manitoba.

TYPES OF INVESTMENT

Direct investment comprised 79% of the total asset value and 83% of the total frequencies of investment transactions. No new businesses were initiated in the Prairie provinces.

INDUSTRY SECTORS

Wholesale trade industries attracted the greatest asset value of French investment, 70% of the total to the Prairies. One investment transaction in this sector, dealing with a mining machinery, equipment and supplies establishment, alone comprised 68% of the total asset value of investment to the Prairies. Mining (20%) was also significant.

In terms of the frequency of investment transactions, manufacturing (33%), mining (17%), petroleum and natural gas (17%), wholesale trade (11%) and business services (11%) were most popular.

FRANCE - PRAIRIE PROVINCES 1985-1990 OVERVIEW TOTAL ASSETS

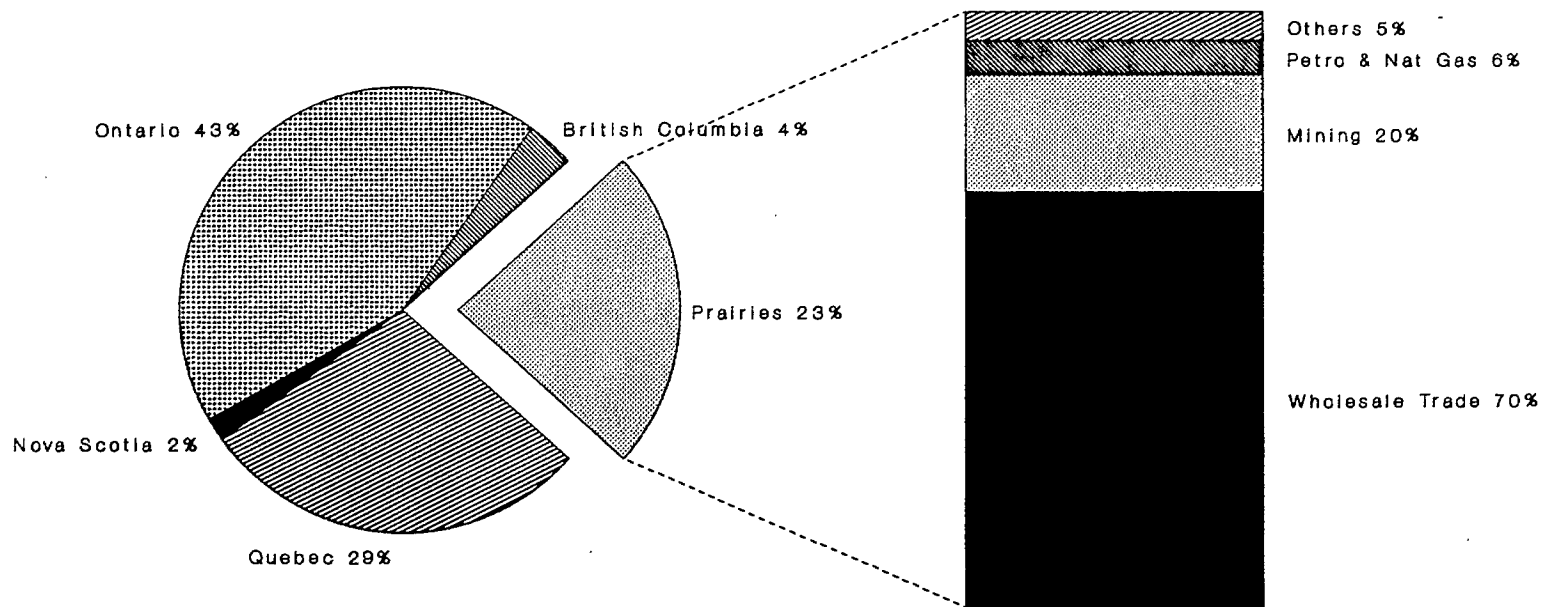

Comparison with Rest of Canada

Industrial Sectors

All investments were acquisitions, of which 79% were direct. All investment is included in this graph.

FRANCE - PRAIRIE PROVINCES 1985-1990 OVERVIEW TOTAL ASSETS

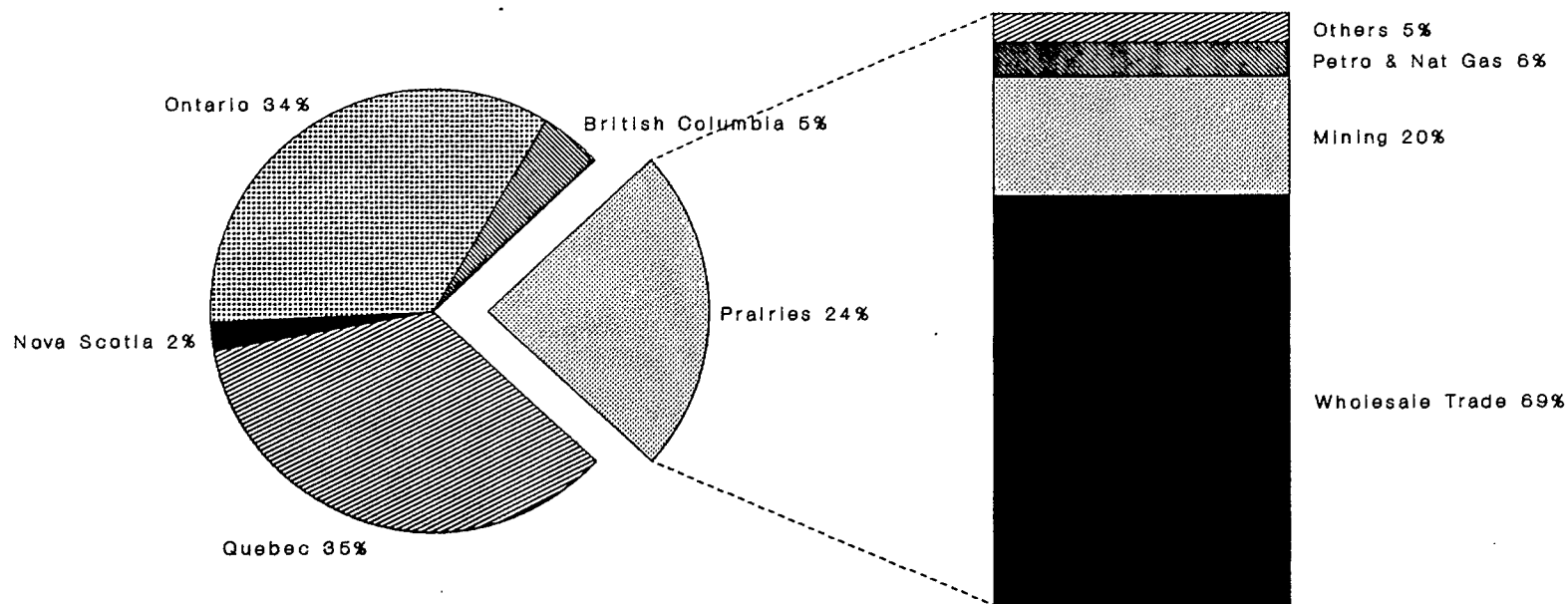

Comparison with Rest of Canada

Industrial Sectors

All investments were acquisitions, of which 79% were direct. Only direct investment is included in this graph.

FRANCE - PRAIRIE PROVINCES 1985-1990

OVERVIEW

TOTAL FREQUENCIES

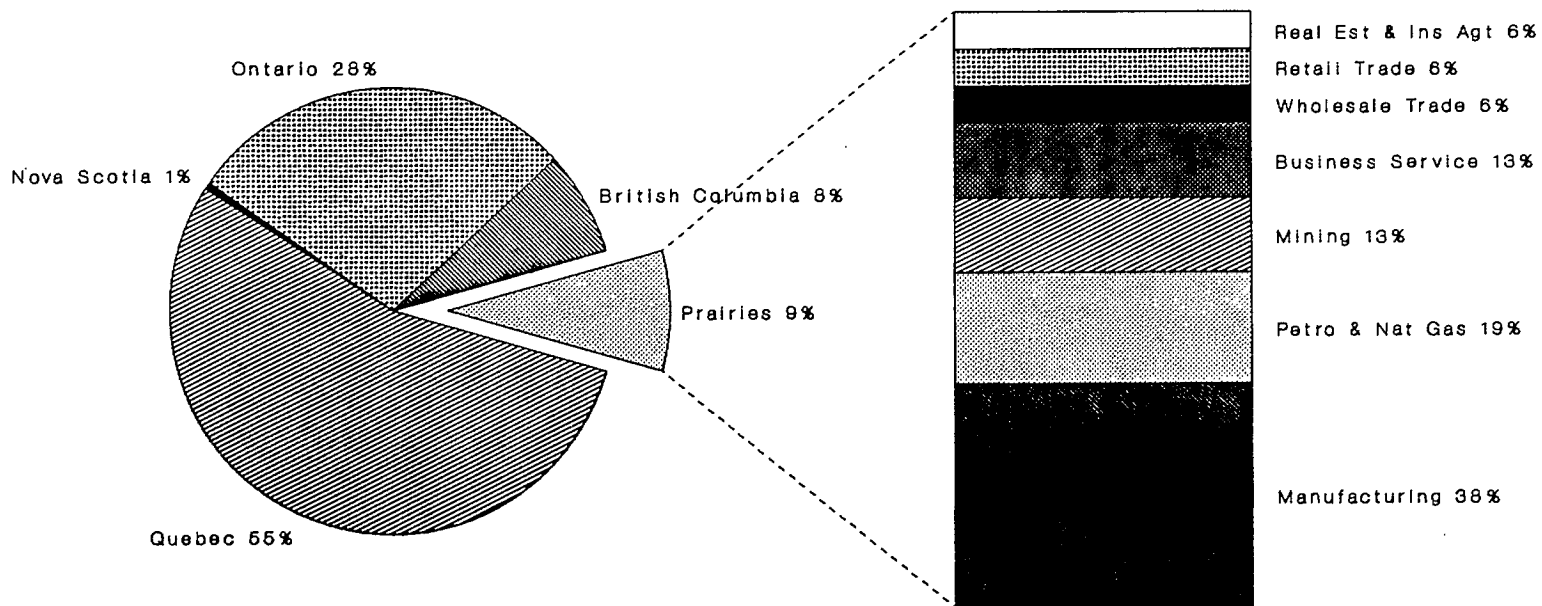

Comparison with Rest of Canada

Industrial Sectors

All investments were acquisitions, of which 83% were direct. Only direct investment is included in this graph.

FRANCE - PRAIRIE PROVINCES 1985-1990 OVERVIEW TOTAL FREQUENCIES

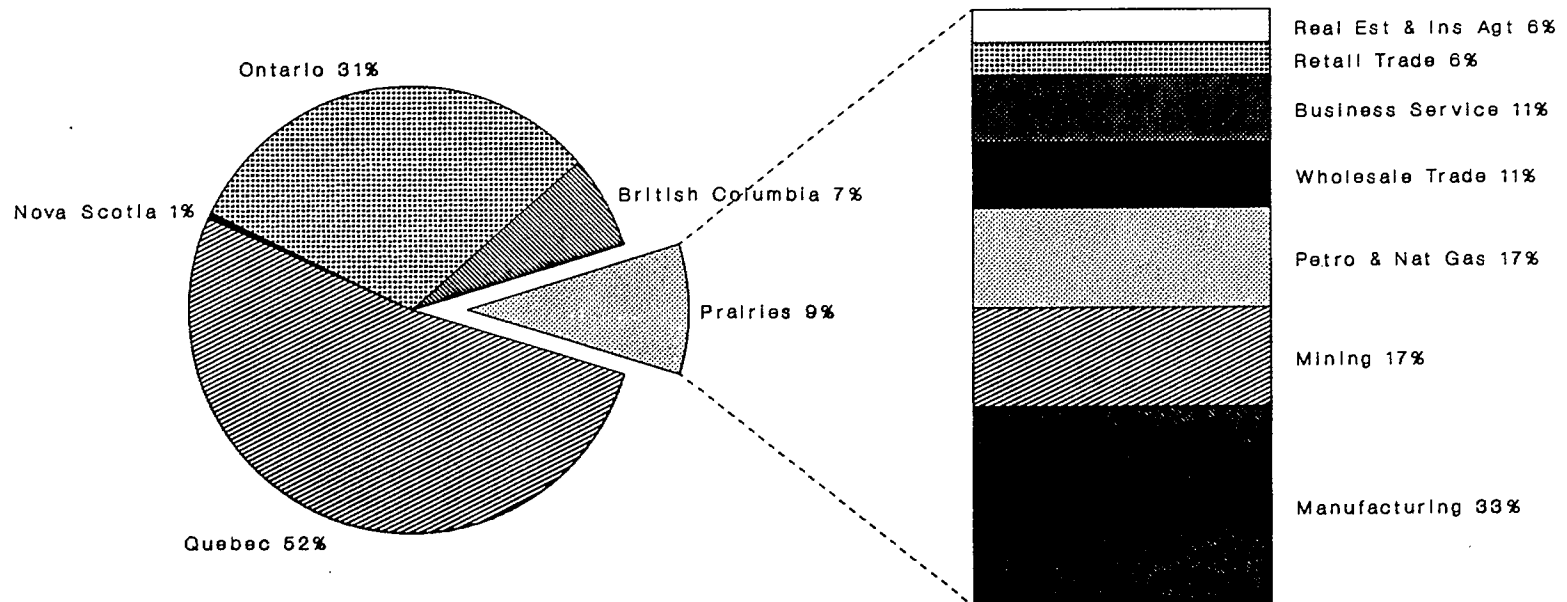

Comparison with Rest of Canada

Industrial Sectors

All investments were acquisitions of which, 83% were direct. All investment is included in this graph.

FRANCE - PRAIRIE PROVINCES 1985-1990 COMPARISON BETWEEN PROVINCES

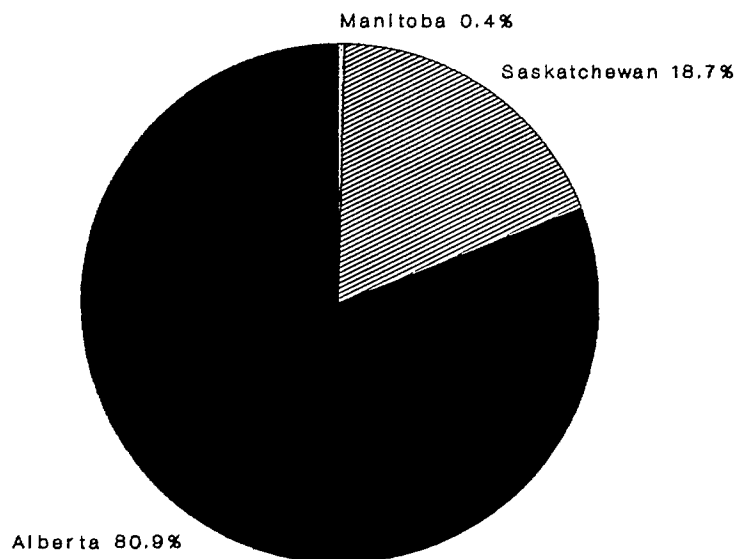

Total Asset Value

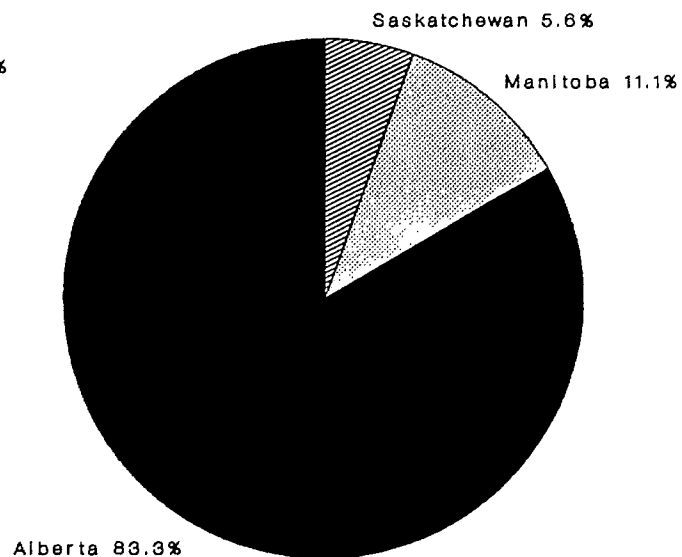

Total Frequency

includes direct, indirect and incidental investment

FRANCE - PRAIRIE PROVINCES 1985-1990 COMPARISON BETWEEN PROVINCES

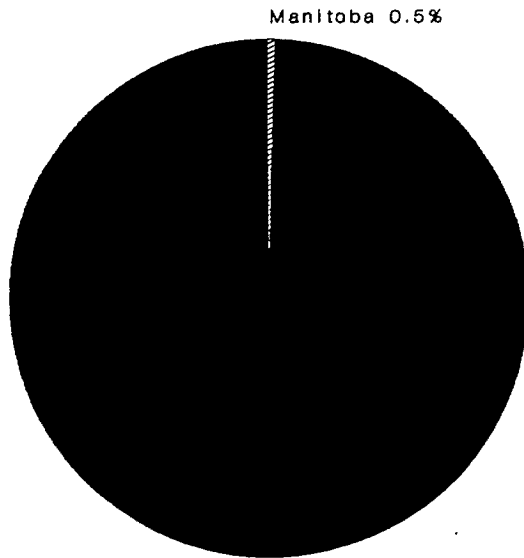

Alberta 99.5%

Total Asset Value

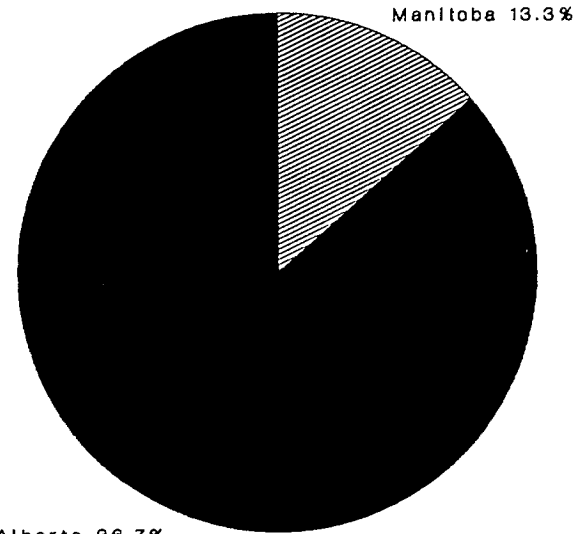

Alberta 86.7%

Total Frequency

direct investment only

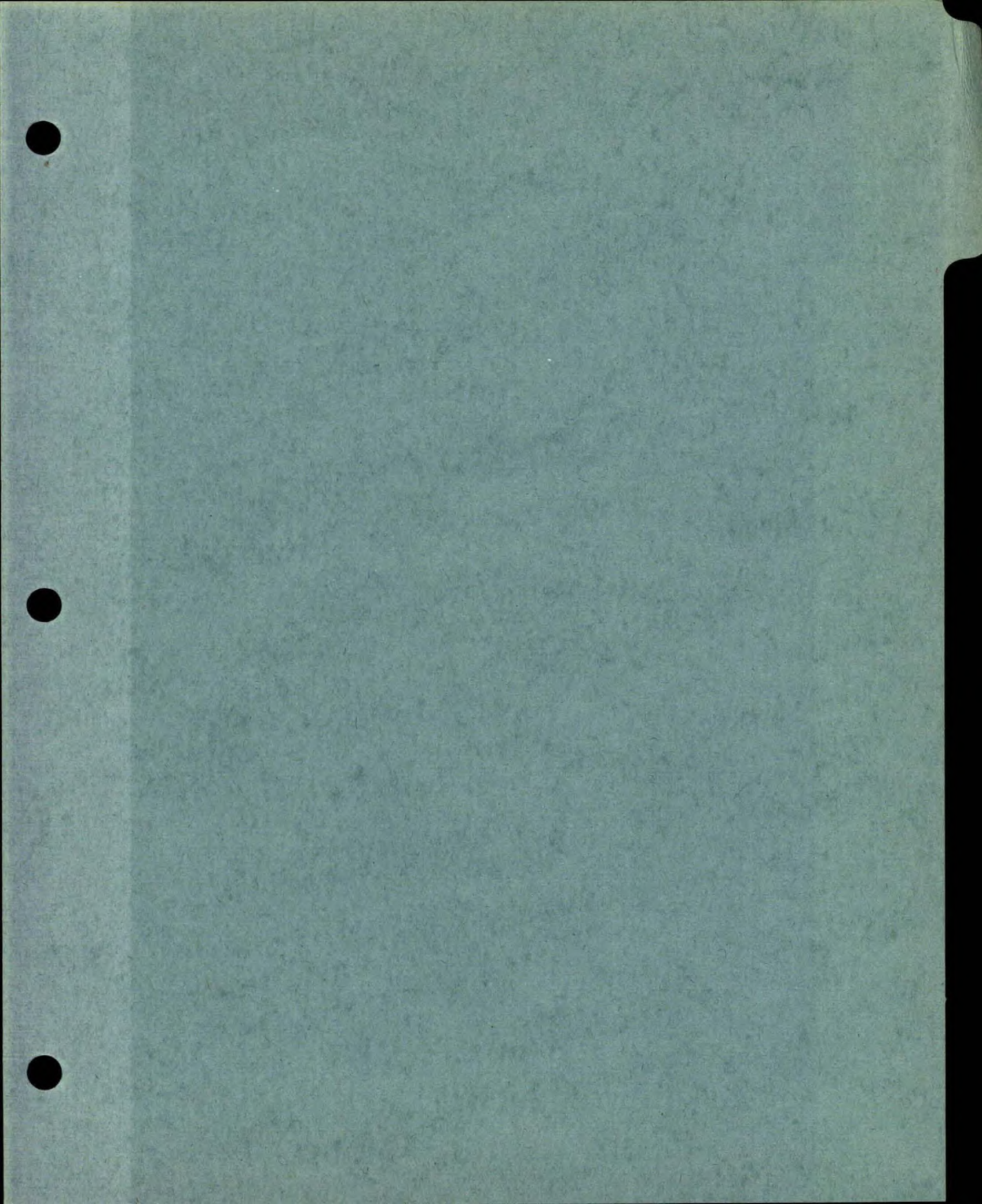

FRANCE - MANITOBA 1985-1990 OVERVIEW TOTAL ASSETS

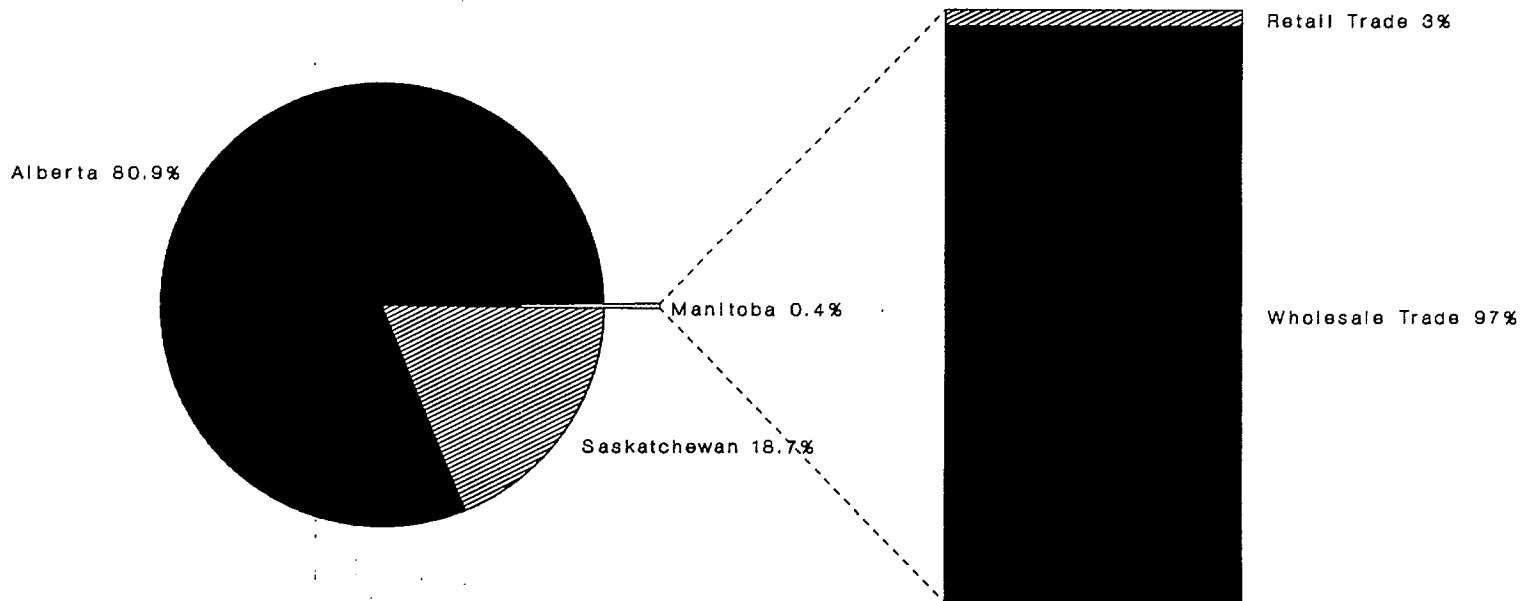

Comparison with Rest of Canada

Industrial Sectors

Only two investment transactions, both direct acquisitions, occurred.

FRANCE - MANITOBA 1985-1990 OVERVIEW TOTAL FREQUENCIES

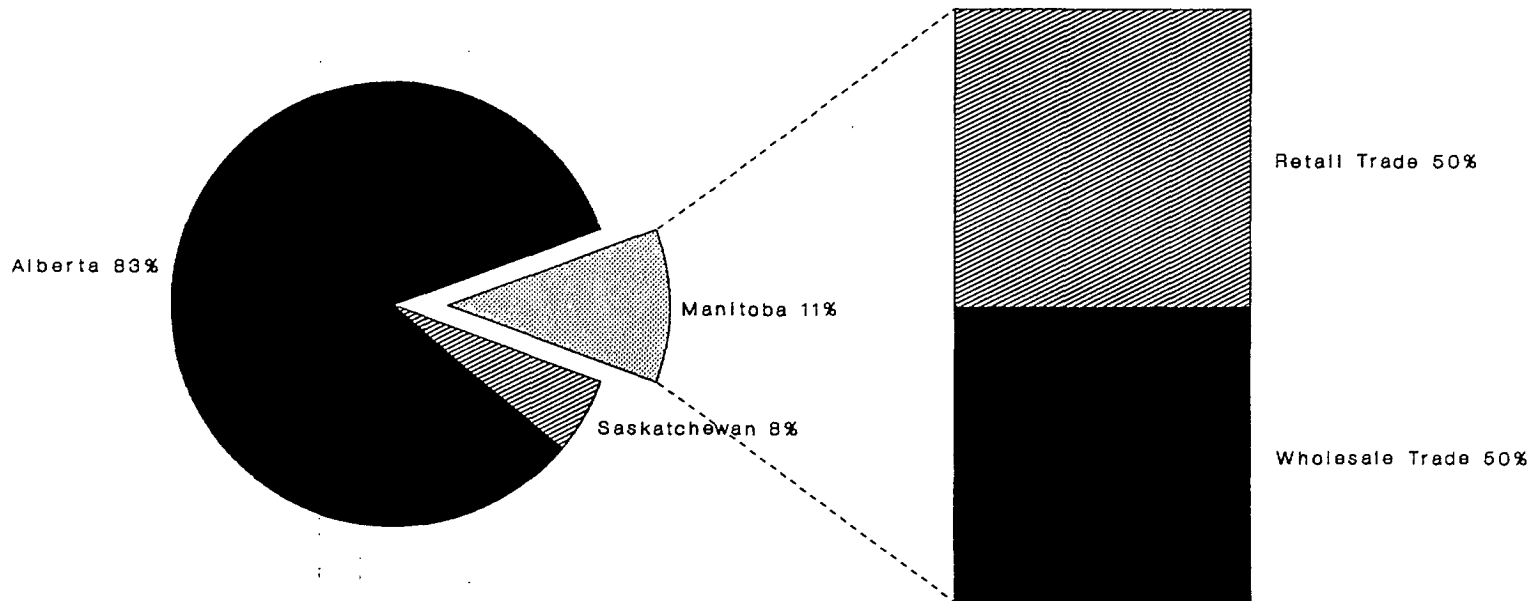

Comparison with Rest of Canada

Industrial Sectors

Only two investment transactions, both direct acquisitions, occurred.

FRANCE - SASKATCHEWAN 1985-1990 OVERVIEW TOTAL ASSETS

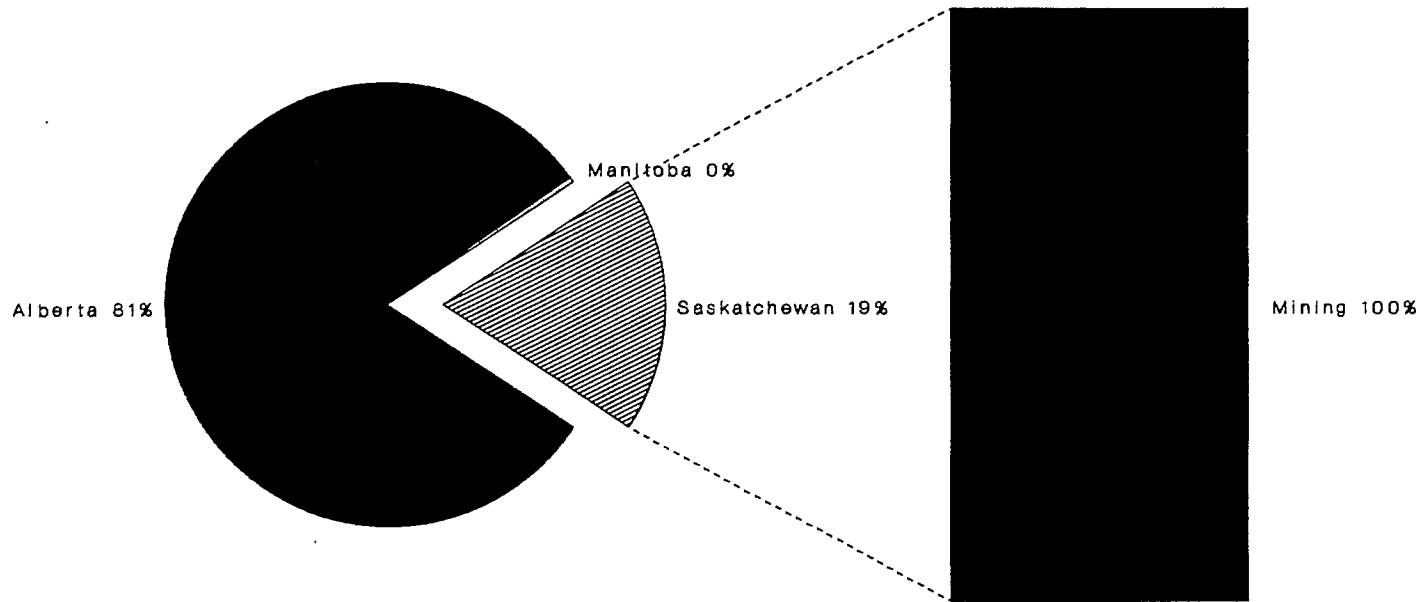

Comparison with Rest of Canada

Industrial Sectors

Only one investment transaction, a indirect aquisition in the mining sector was made.

FRANCE - SASKATCHEWAN 1985-1990 OVERVIEW TOTAL FREQUENCIES

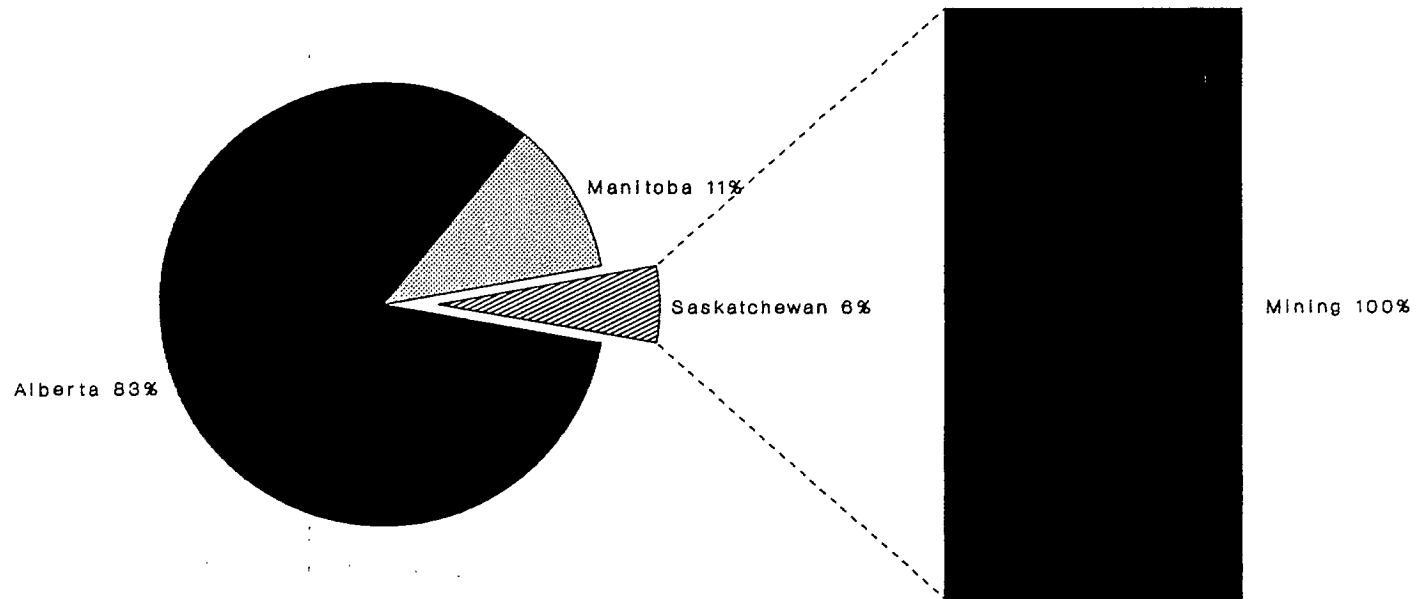

Comparison with Rest of Canada

Industrial Sectors

Only one investment transaction, an indirect acquisition in the mining sector was made.

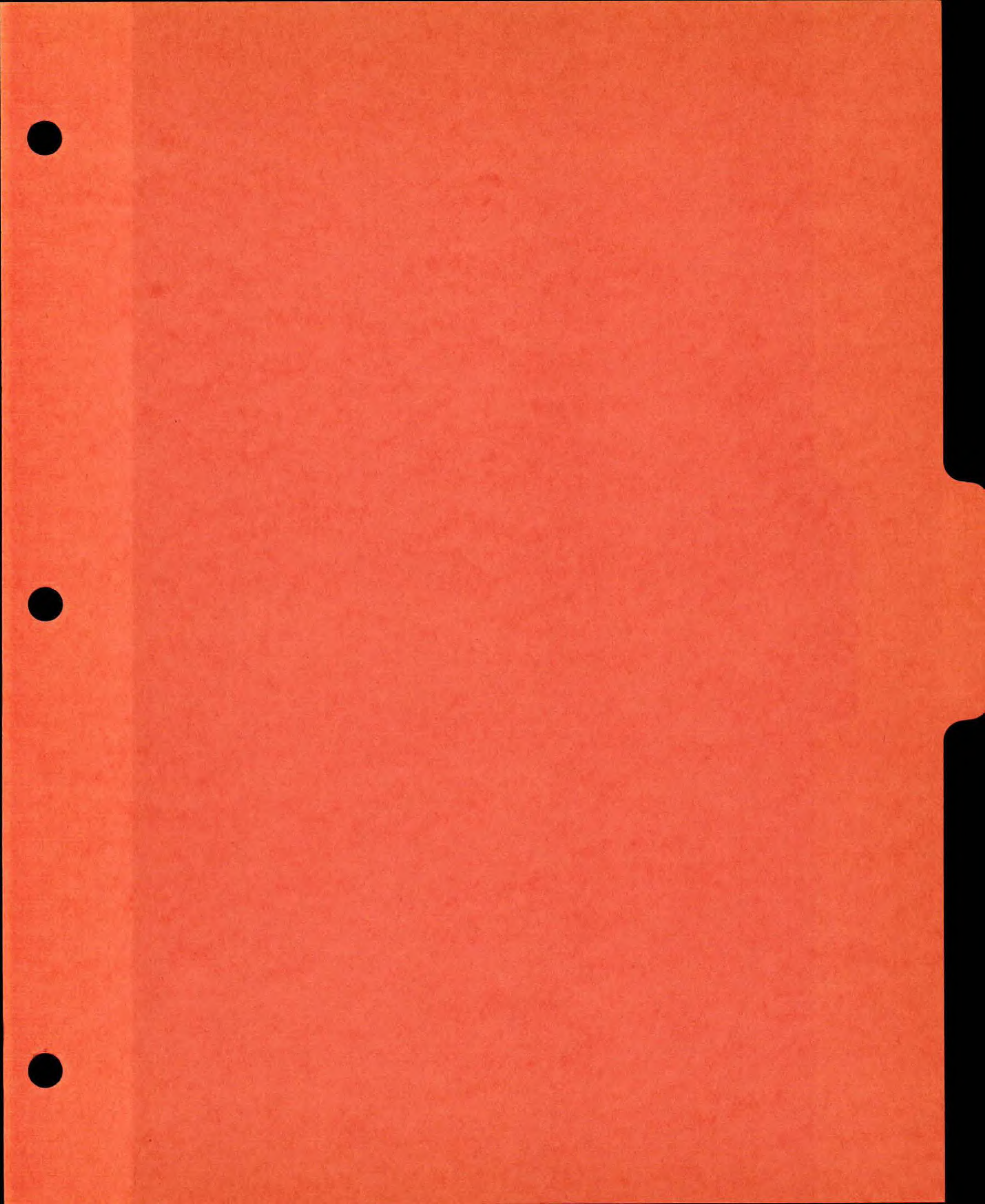

FRANCE - ALBERTA 1985-1990 OVERVIEW TOTAL ASSETS

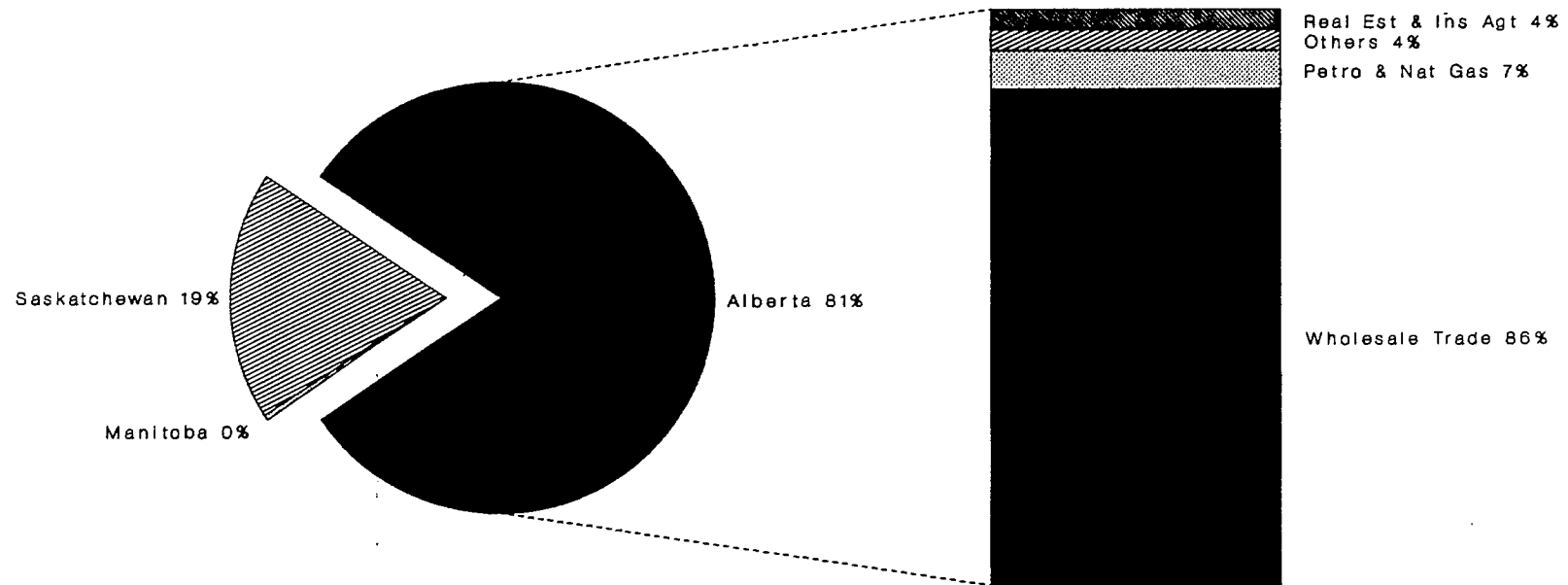

Comparison with Rest of Canada

Industrial Sectors

All investments were acquisitions, of which 97% were direct. All investment is included in this graph.

FRANCE - ALBERTA 1985-1990 OVERVIEW TOTAL ASSETS

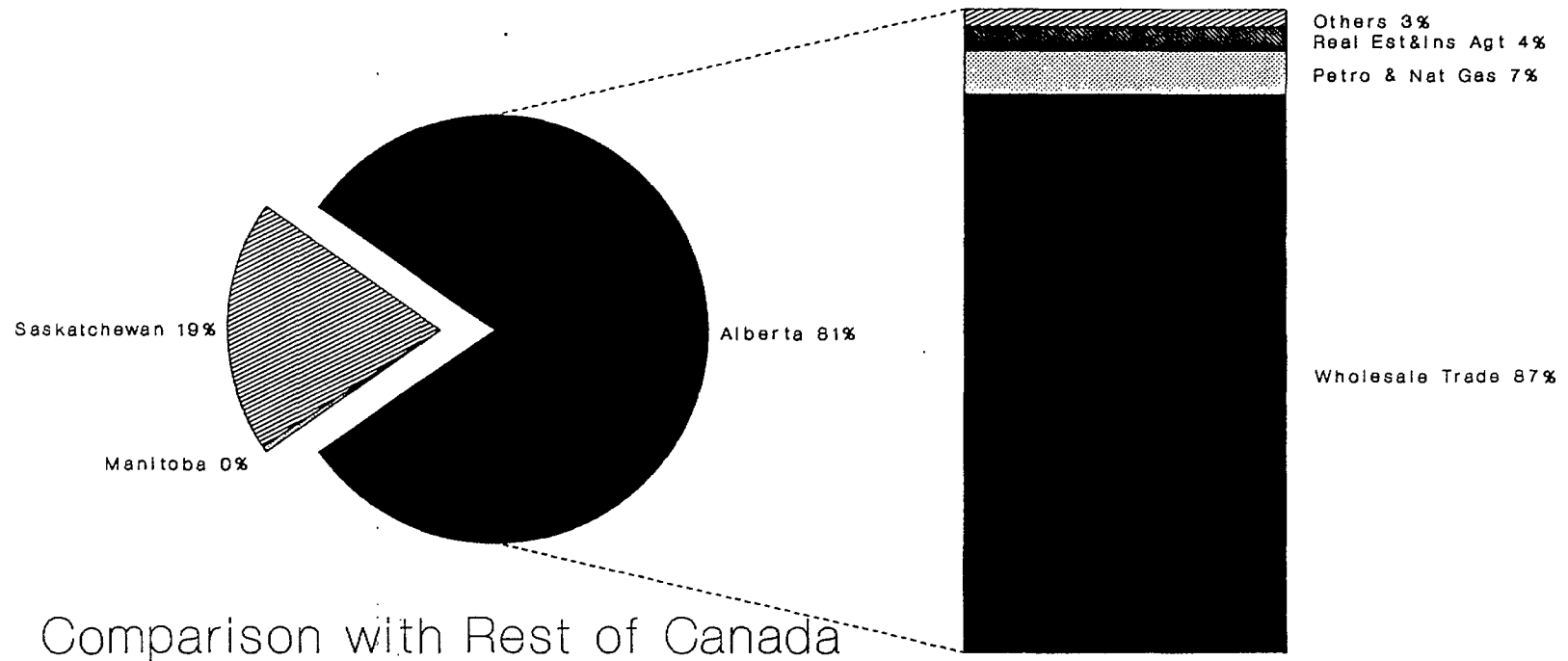

Comparison with Rest of Canada

Industrial Sectors

All investments were acquisitions, of which 97% were direct. Only direct investment is included in this graph.

FRANCE - ALBERTA 1985-1990 OVERVIEW TOTAL FREQUENCIES

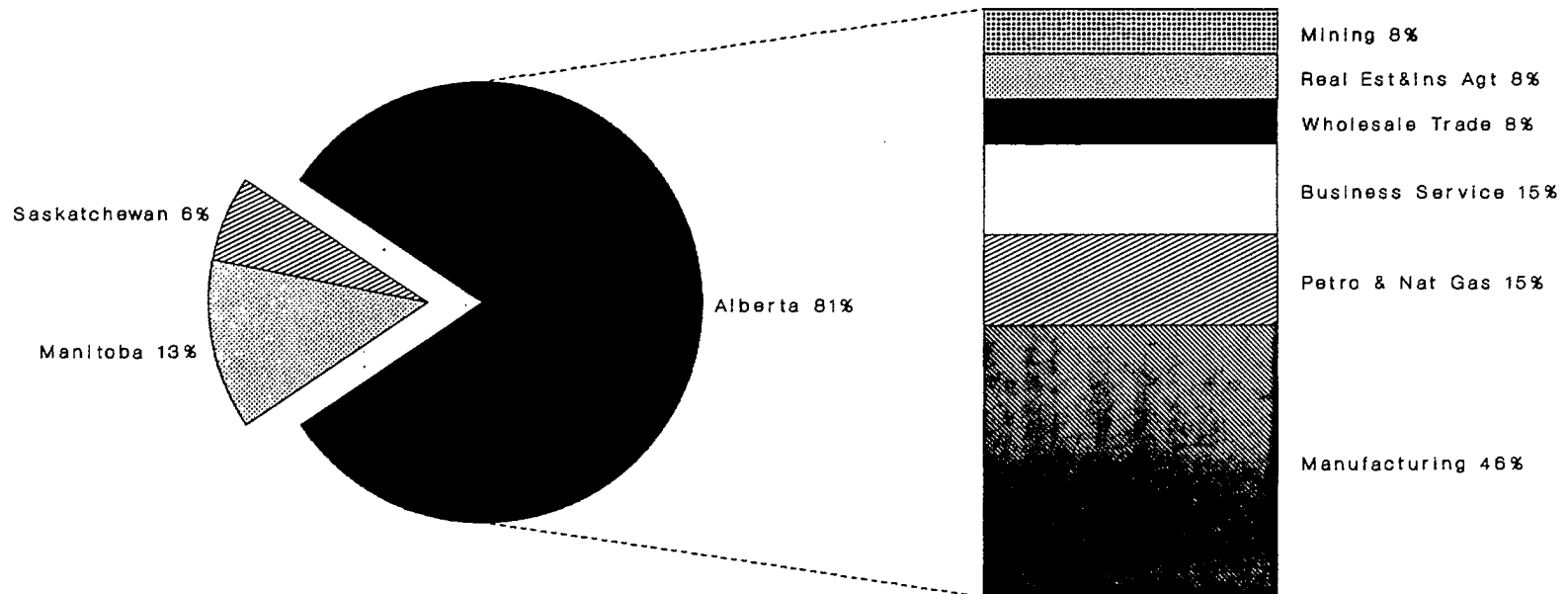

Comparison with Rest of Canada

Industrial Sectors

All investments were acquisitions, of which 87% were direct. Only direct investment is included in this graph.

FRANCE - ALBERTA 1985-1990 OVERVIEW TOTAL FREQUENCIES

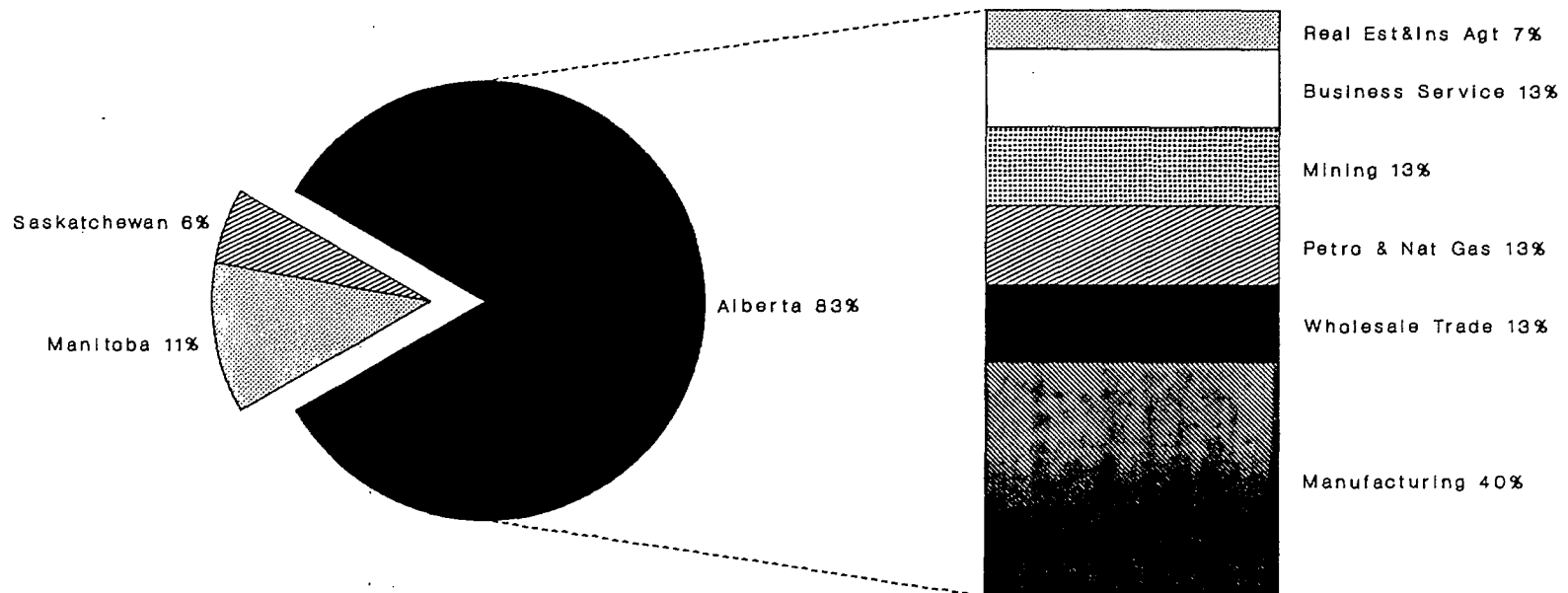

Comparison with Rest of Canada

Industrial Sectors

All investments were acquisitions, of which 87% were direct. All investment is included in this graph.

FRANCE - BRITISH COLUMBIA - AN OVERVIEW

OVERVIEW

British Columbia attracts 4% of the total asset value and 7% of the frequency of French investment.

TYPES OF INVESTMENT

All investment to British Columbia was direct. Only one transaction involved a new business. It comprised 10% of the total asset value of French investment to B.C.

INDUSTRY SECTORS

Four sectors were the targets of French investment. Ranked according to their proportion of the asset value of investment to B.C., they were: wholesale trade (45%), mining (39%), petroleum and natural gas (10%), and manufacturing (6%). Ranked by the frequency of investment, they were manufacturing (38%), wholesale trade (31%), mining (23%), and petroleum and natural gas (8%).

FRANCE - BRITISH COLUMBIA 1985-1990 OVERVIEW TOTAL ASSETS

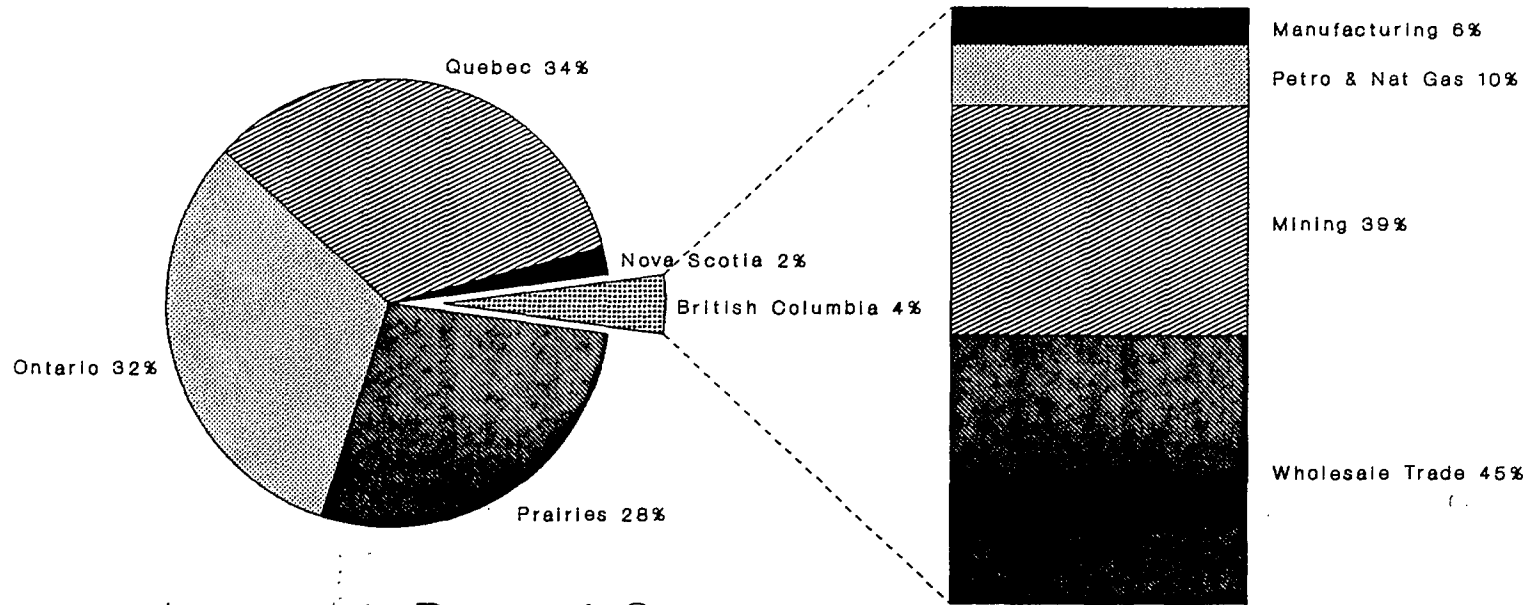

Comparison with Rest of Canada

Industrial Sectors

Direct investment only was made.

FRANCE - BRITISH COLUMBIA 1985-1990 OVERVIEW TOTAL FREQUENCIES

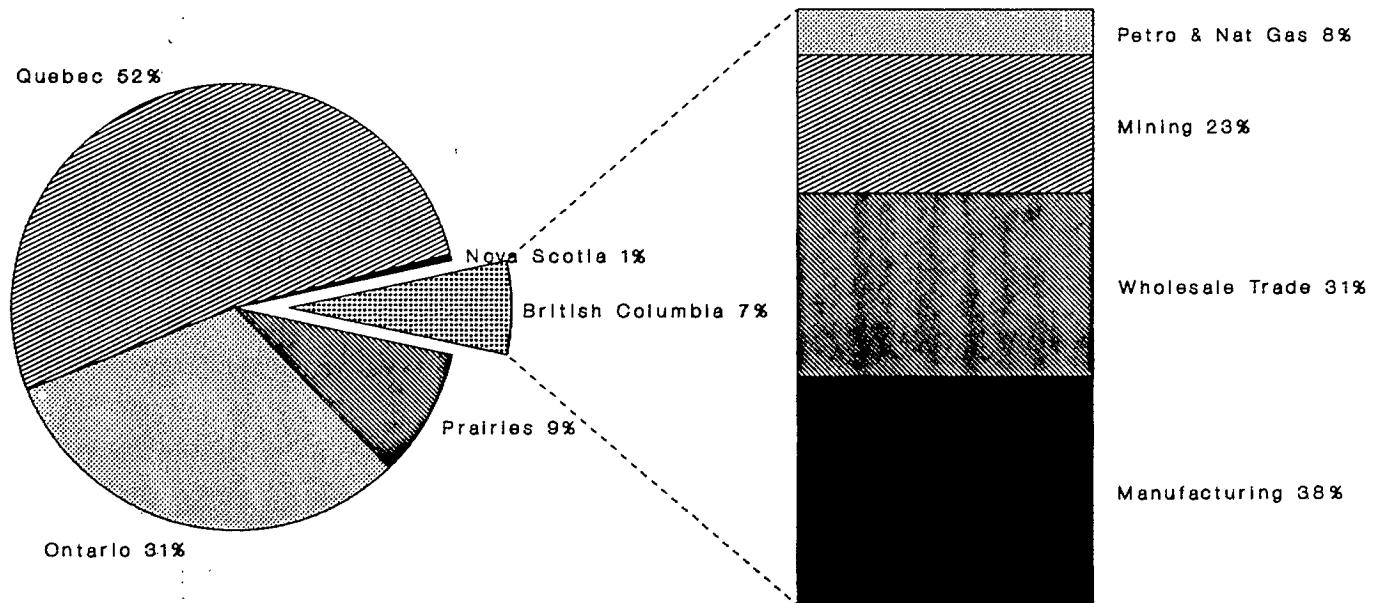

Comparison with Rest of Canada

Industrial Sectors

Direct investment only was made.

FRANCE - BRITISH COLUMBIA 1985-1990

TYPES OF INVESTMENT

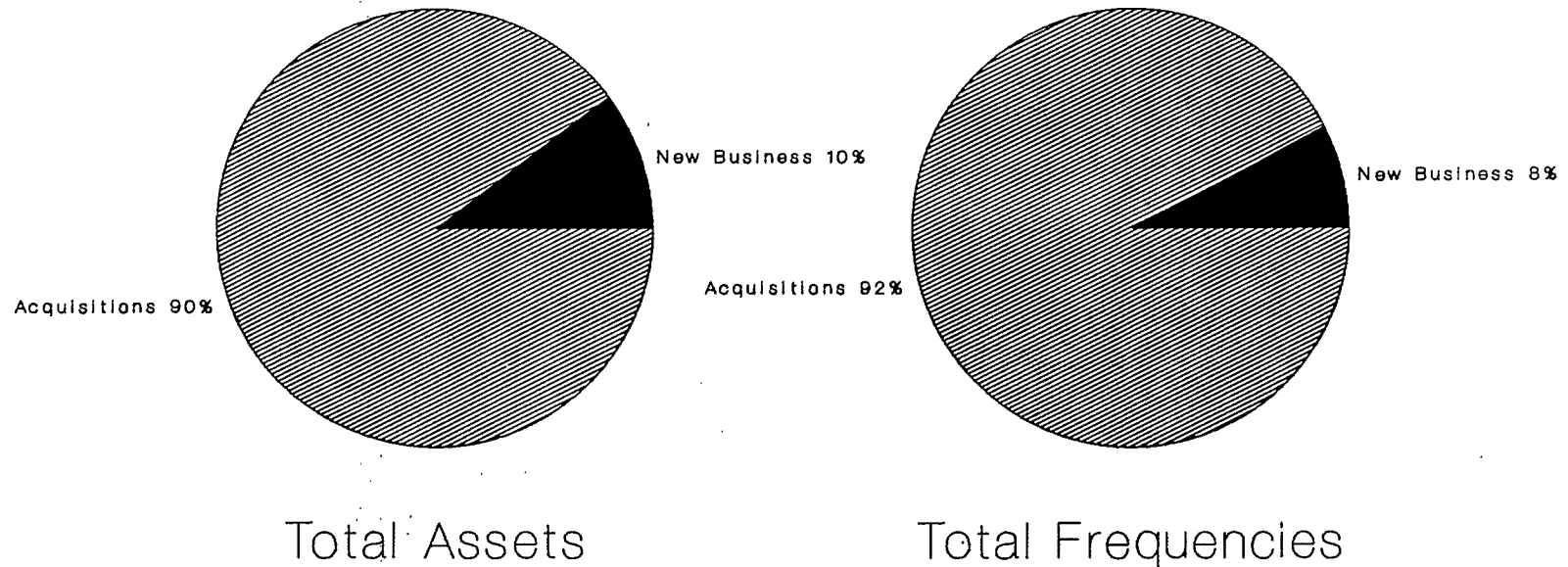

Only direct investment was made.

FRANCE - BRITISH COLUMBIA 1985-1990

INDUSTRY SECTORS

TOTAL ASSETS

Petro & Nat Gas 100%

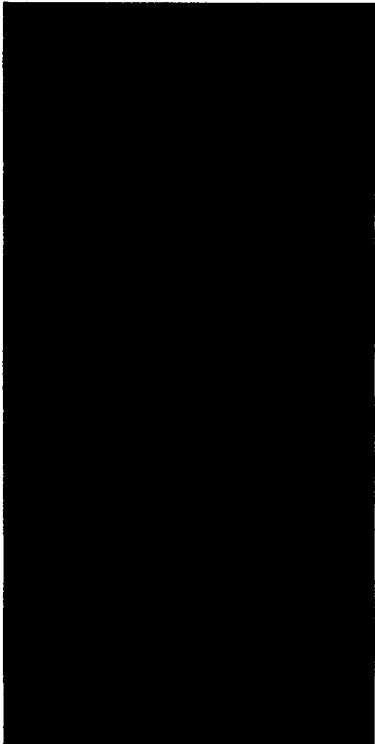

New Business

Only direct investment was made.

Manufacturing 7%

Mining 43%

Wholesale Trade 50%

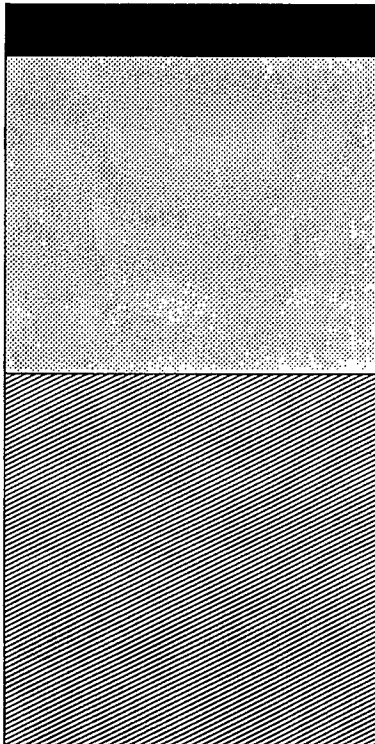

Acquisitions

FRANCE - BRITISH COLUMBIA 1985-1990

INDUSTRY SECTORS

TOTAL FREQUENCIES

Petro & Nat Gas 100%



New Business

Only direct investment was made.

Mining 25%

Wholesale Trade 33%

Manufacturing 42%

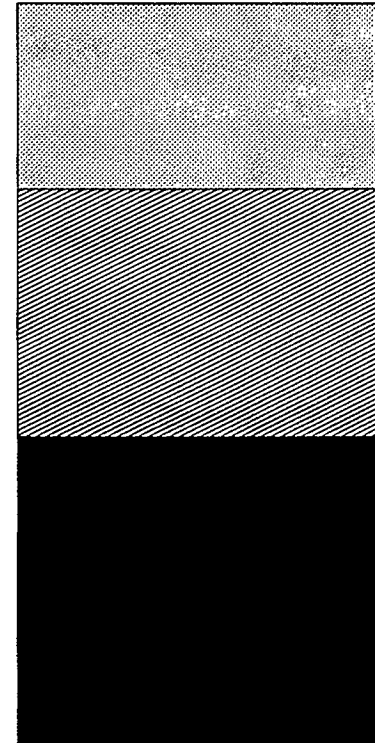

Acquisitions

FRANCE - URBAN CENTRES - AN OVERVIEW

Four urban centres were studied: Montreal, Toronto, Calgary, and Vancouver. A significant amount of French investment to Canada, 45% of the total asset value and 31% of the total frequency, is targeted to one of these four cities.

Toronto attracts the greatest asset value of French investment with 48% of the urban centre total. Calgary (37%) follows though only four transactions were destined there. Montreal (15%) secures substantially less of the asset value of investment. It is, however, the most popular target for French investment with 68% of the total urban centre transactions. Only two transactions occurred in Vancouver comprising a negligible portion of the asset value of investment.

MONTREAL

OVERVIEW

23% of the asset value of investment and 40% of investment transactions in Quebec are placed in Montreal. Numerous investments in the wholesale trade and manufacturing industries comprising 75% of the asset value of investment to Quebec occurred outside Montreal.

TYPES OF INVESTMENT

98% of the asset value and 95% of the frequency of investment is direct. New business comprises 18% of the asset value and 68% of the frequency of direct investment. Numerous, very low asset value businesses were initiated in the wholesale trade sector.

INDUSTRY SECTORS

Retail trade and manufacturing attracted the greatest asset value of investment with 39% and 29% respectively of the total investment to Montreal. One direct acquisition of prescription drug and/or patent medical store (retail trade) alone comprised

FRANCE - URBAN CENTRES - AN OVERVIEW

MONTREAL

INDUSTRY SECTORS

38% of the asset value of investment to Montreal. Construction (19%), accommodation, food and beverages (8%), and wholesale trade (5%) followed.

Wholesale trade was the most frequent destination for French investment to Montreal with 45% of the total. Manufacturing (15%), retail trade (15%), business services (15%), and construction (10%) were also frequent choices.

TORONTO

OVERVIEW

49% of the asset value and 22% of the total frequency of Ontario investment is made in Toronto.

TYPES OF INVESTMENT

Direct investment comprises 84% of the asset value of investment and 69% of the total investment transactions in Toronto. New businesses accounted for a negligible portion of the total asset value of direct investment. Yet, they constitute 44% of the direct investment transactions. This contrast can be explained by numerous, small businesses initiated in wholesale trade industries.

INDUSTRY SECTORS

Manufacturing (81%) and finance and insurance (19%) were the most prominent targets, according to total asset values of investment in Toronto. A direct acquisition in the pharmaceutical and medicine industry (manufacturing) alone comprised half of the asset value of French investment to Toronto.

Investment transactions most frequently occur in the manufacturing (54%) and wholesale trade (23%).

FRANCE - URBAN CENTRES - AN OVERVIEW

CALGARY

OVERVIEW

88% of the asset value while only 27% of the total frequency of investment transactions in Alberta are placed in Calgary.

TYPES OF INVESTMENT

Nearly all of the asset value and 75% of investment transactions were direct. No new businesses were initiated in Calgary.

INDUSTRY SECTORS

Wholesale trade drew most, 98%, of the asset value of French investment to Calgary. One of the two transactions in this sector, an establishment dealing in mining equipment, machinery, and supplies, alone accounted for 96% and 85% of the total asset value of French investment to Calgary and Alberta respectively.

In terms of frequency of investment, two of the four transactions to Calgary occurred in wholesale trade and the other two, in the business services.

VANCOUVER

OVERVIEW

Only two transactions by French investors were made in Vancouver comprising 3% of the asset value. Both transactions were direct acquisitions in wholesale trade industries.

FRANCE - URBAN CENTRES 1985-1990

OVERVIEW

TOTAL ASSETS

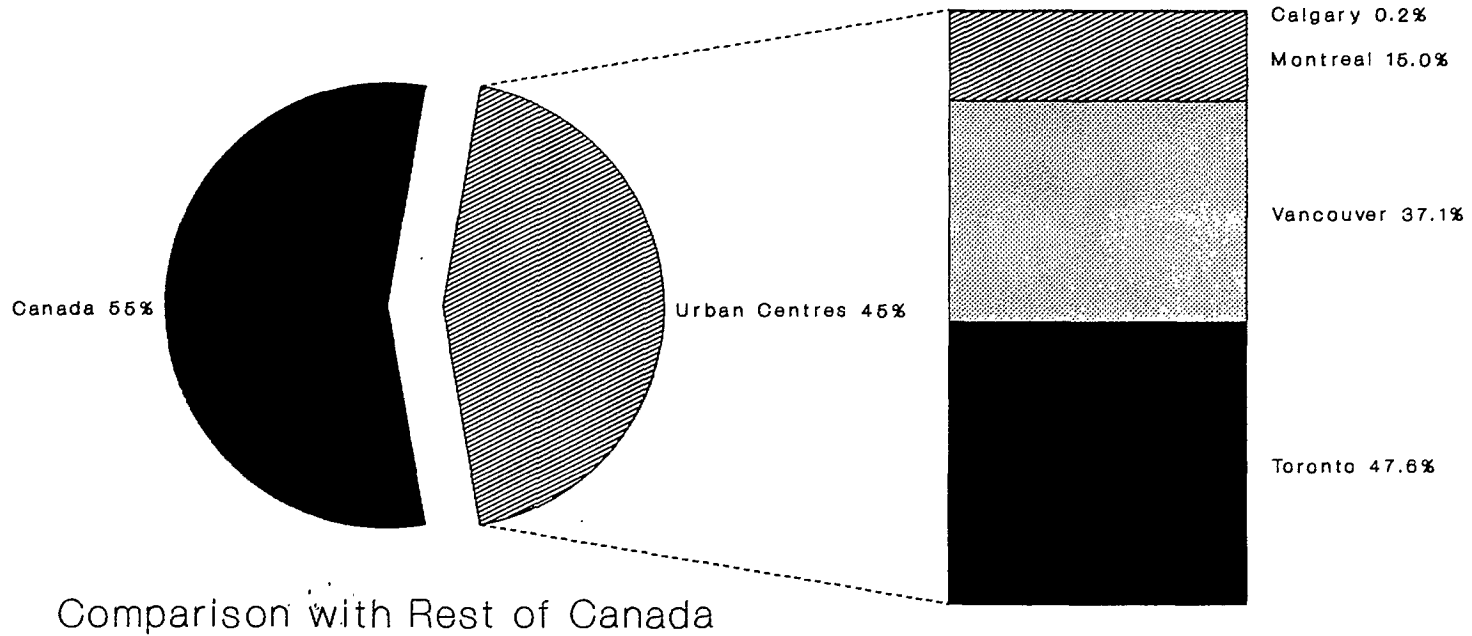

Division Between Urban Centres

includes direct, indirect and incidental investment

FRANCE - URBAN CENTRES 1985-1990

OVERVIEW

TOTAL FREQUENCIES

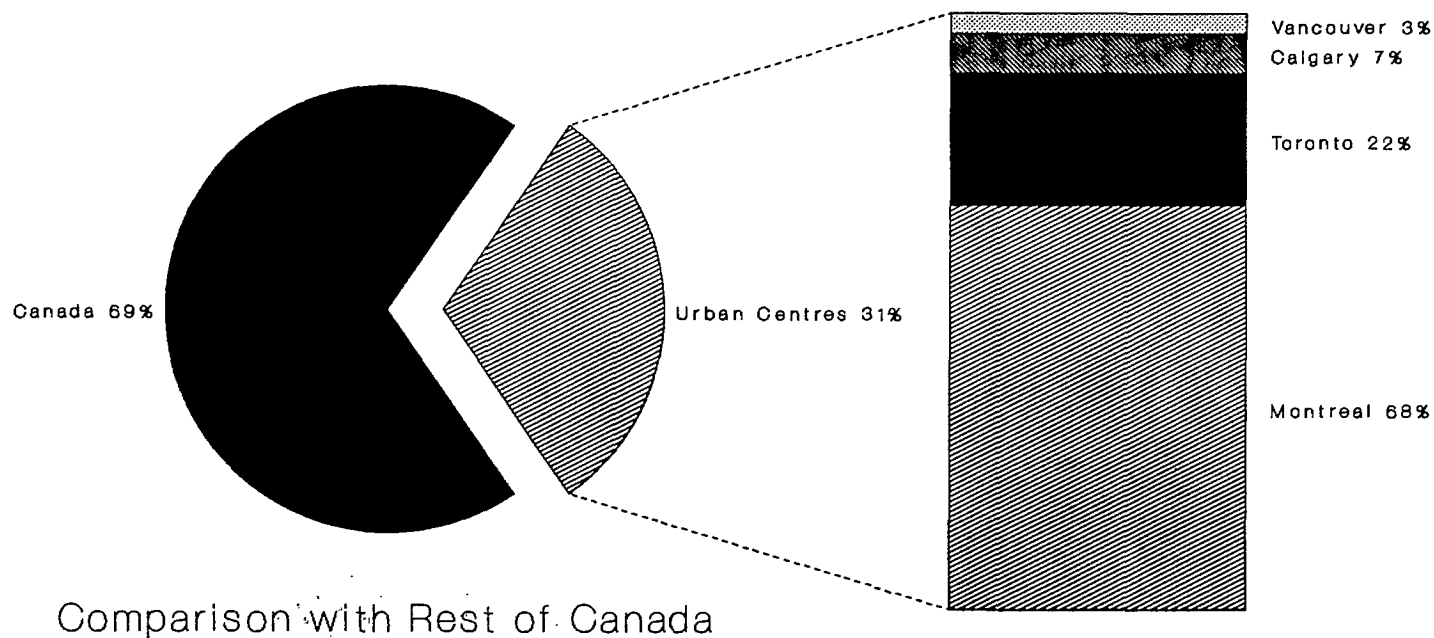

Comparison with Rest of Canada

Division Between Urban Centres

includes direct, indirect and incidental investment

FRANCE - URBAN CENTRES 1985-1990

OVERVIEW

TOTAL FREQUENCIES

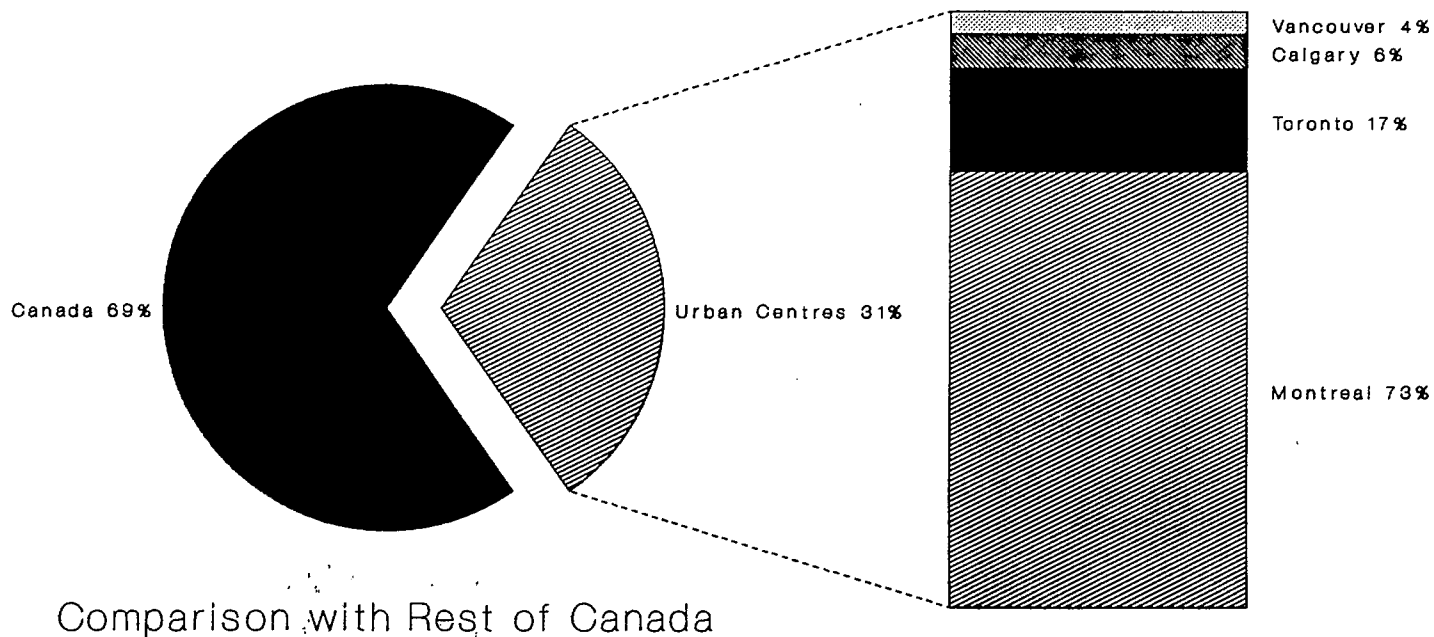

Comparison with Rest of Canada

Division Between Urban Centres

direct investment only

FRANCE - URBAN CENTRES 1985-1990

OVERVIEW

TOTAL ASSETS

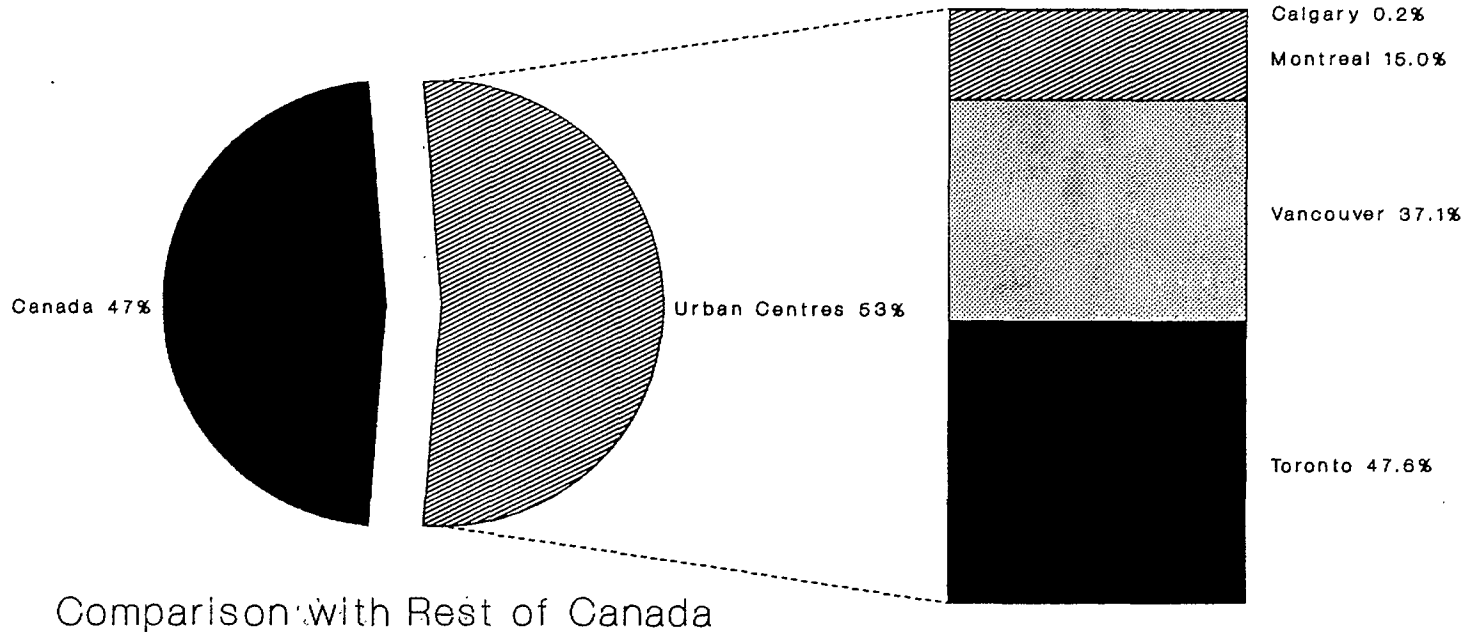

Division Between Urban Centres

direct investment only

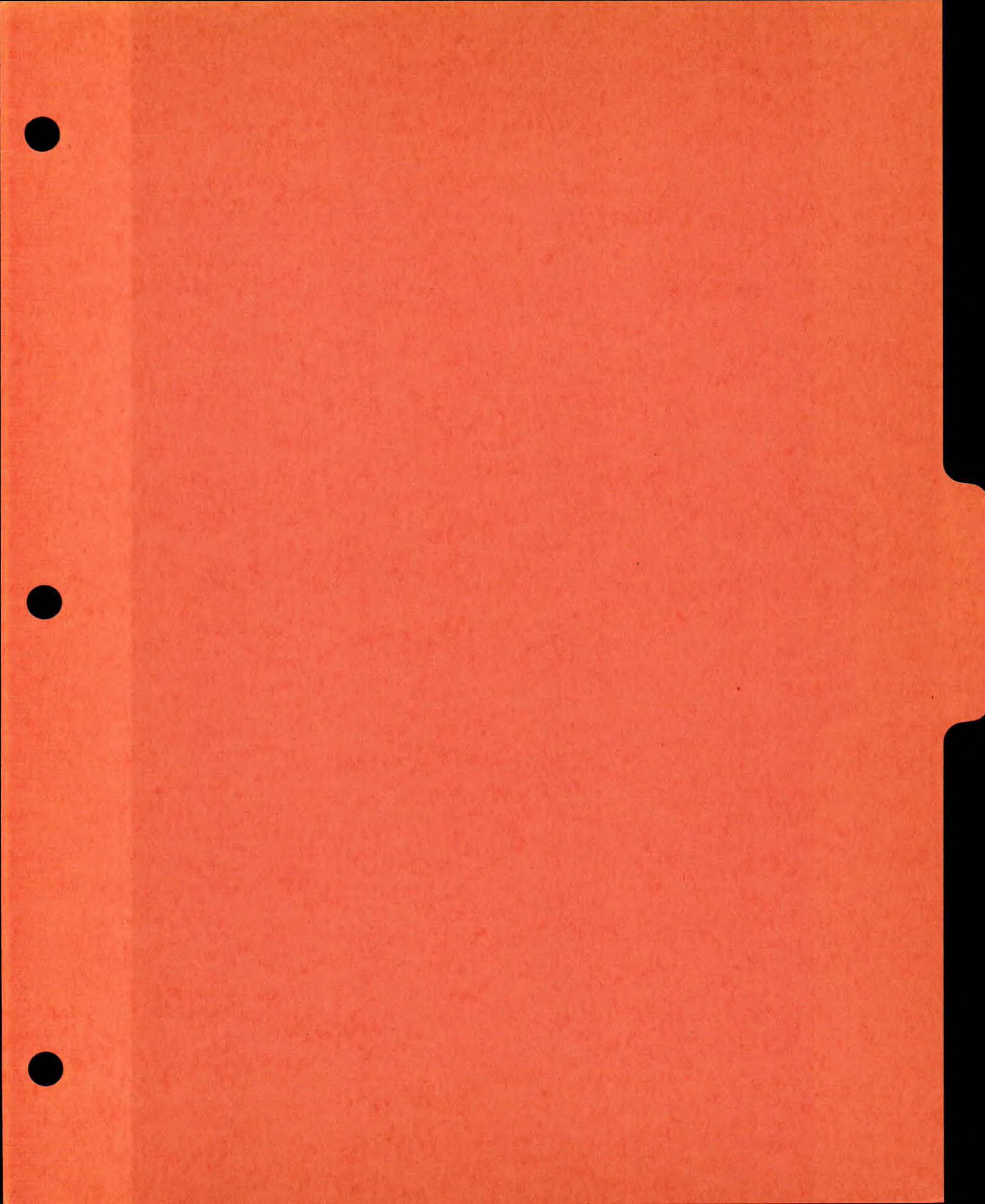

FRANCE - MONTREAL 1985-1990 COMPARISON WITH QUEBEC

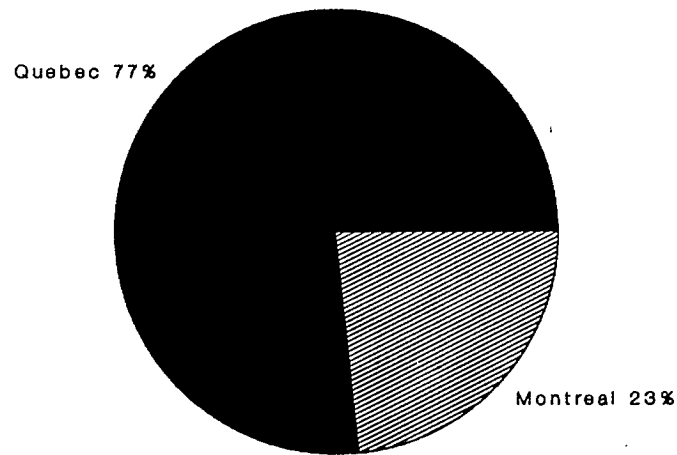

TOTAL ASSETS

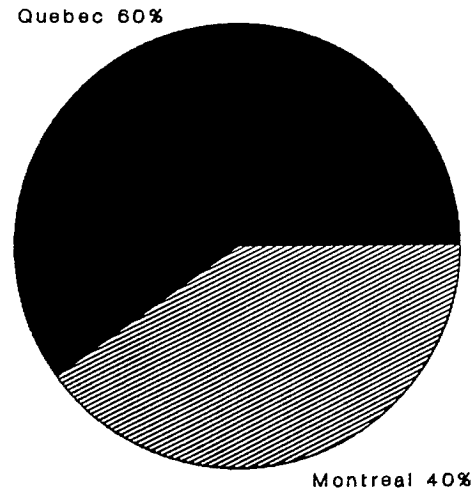

TOTAL FREQUENCIES

includes direct, indirect and incidental investment

FRANCE - MONTREAL 1985-1990 COMPARISON WITH QUEBEC

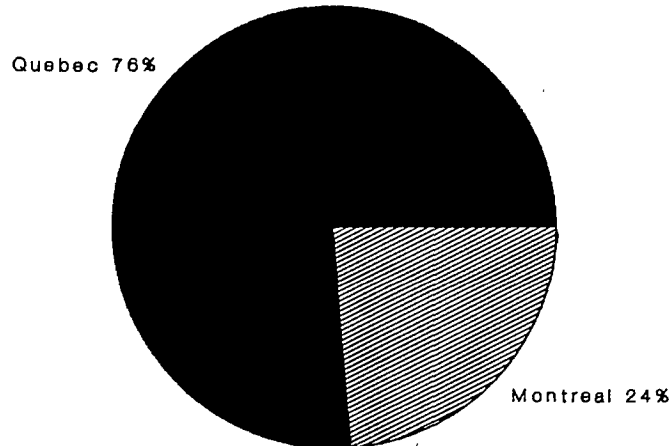

TOTAL ASSETS

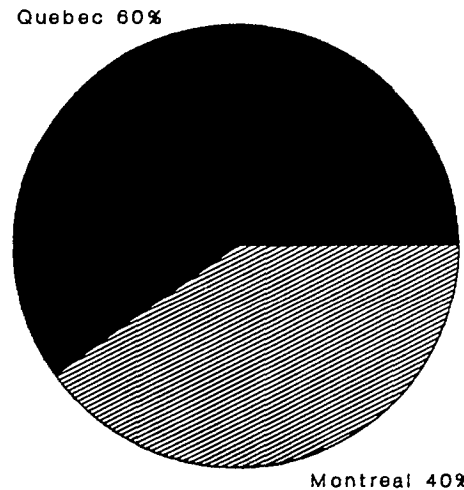

TOTAL FREQUENCIES

direct investment only

FRANCE - MONTREAL 1985-1990

TYPES OF INVESTMENT

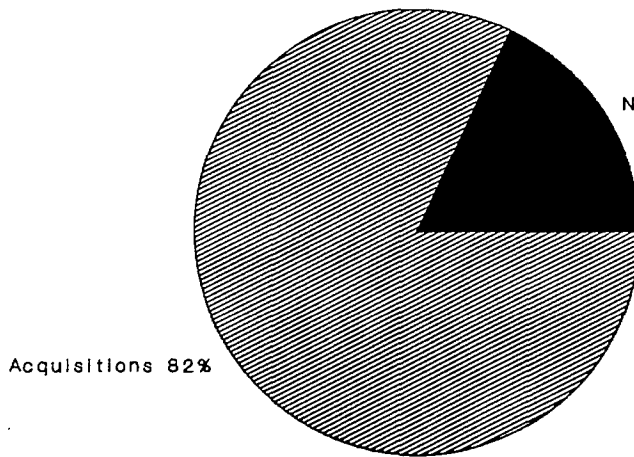

Total Assets

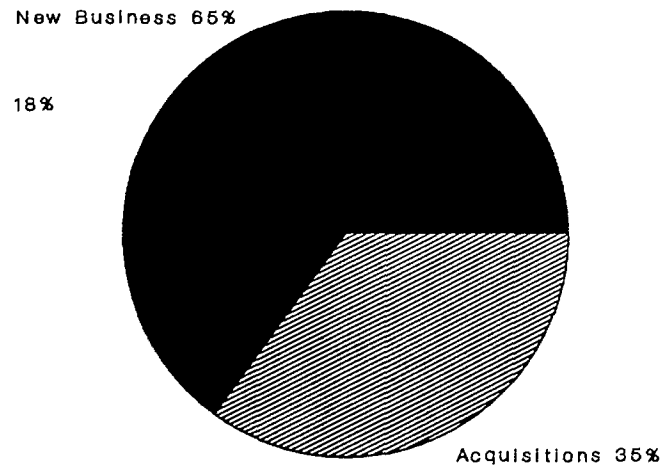

Total Frequencies

includes direct, indirect and incidental investment

FRANCE - MONTREAL 1985-1990

TYPES OF INVESTMENT

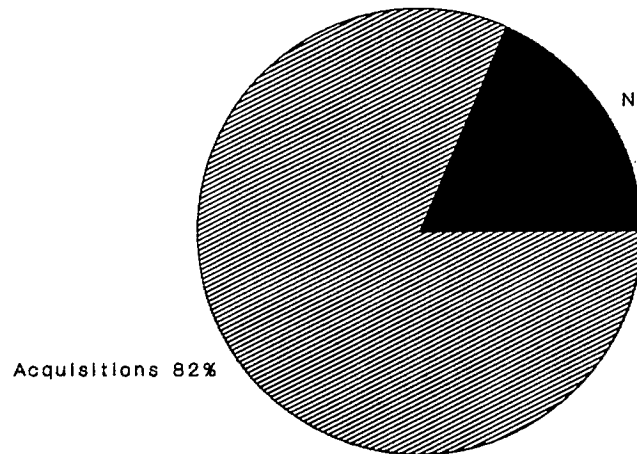

Total Assets

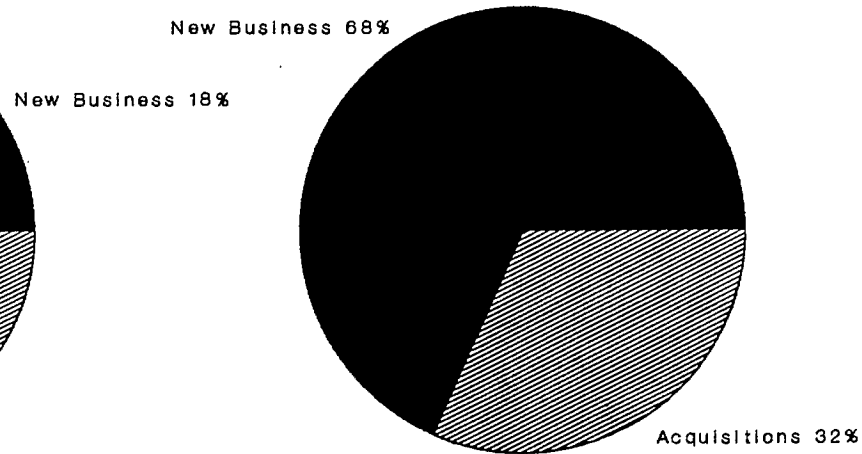

Total Frequencies

direct investment only

FRANCE - MONTREAL 1985-1990

INDUSTRY SECTORS

TOTAL ASSETS

Others 3%
 Business Service 3%
 Manufacturing 4%

Construction 90%

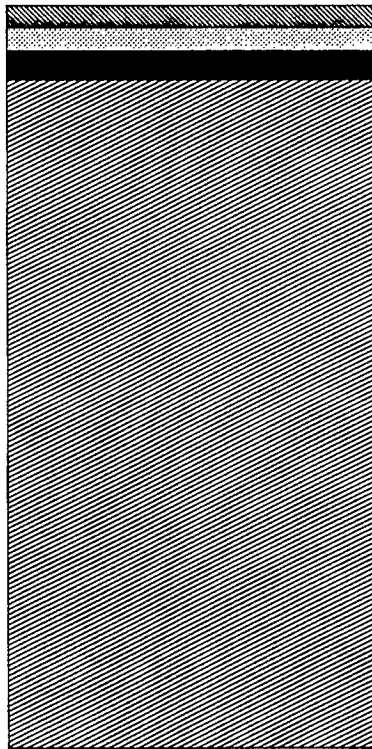

New Business

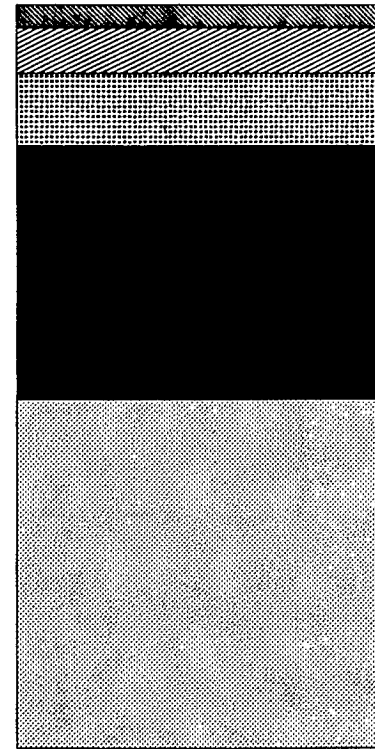

Construction 3%
 Wholesale Trade 6%
 Acc, Food & Bev 10%

Manufacturing 34%

Retail Trade 47%

Acquisitions

includes direct, indirect and incidental investment

FRANCE - MONTREAL 1985-1990

INDUSTRY SECTORS

TOTAL ASSETS

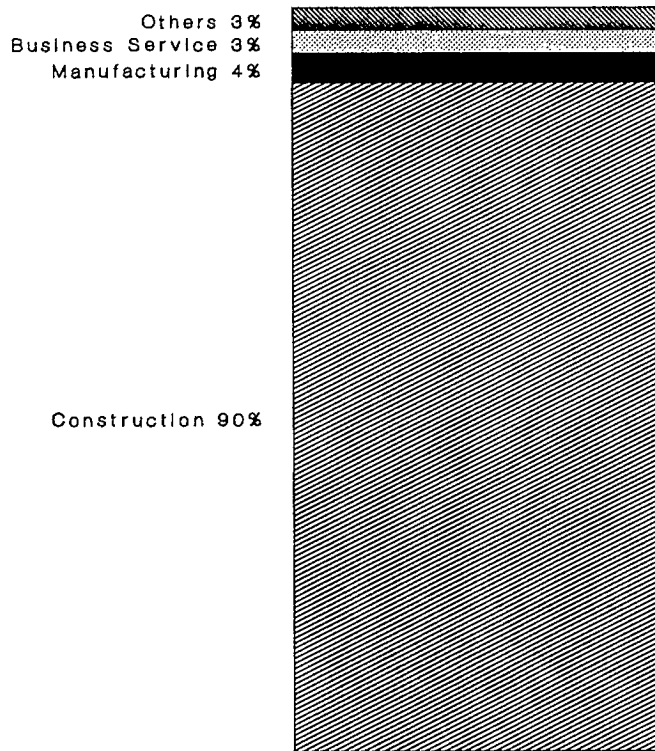

New Business

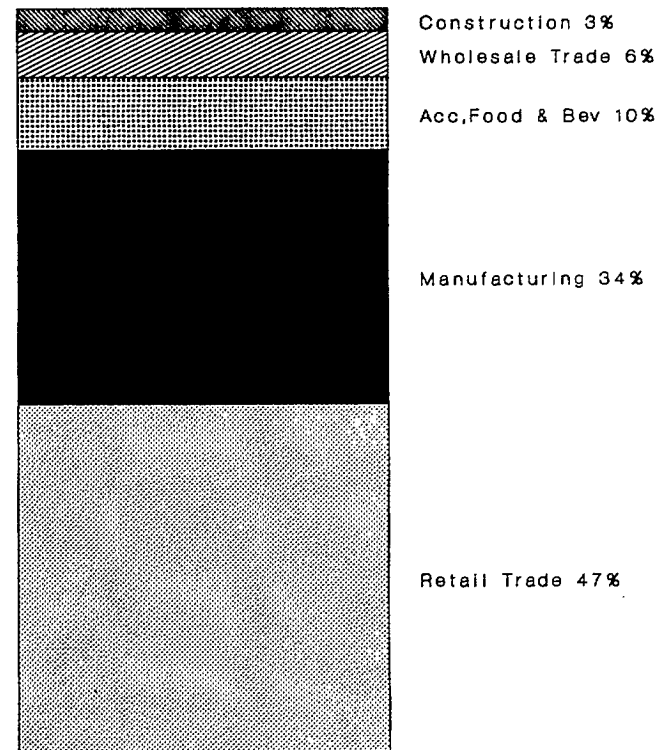

Acquisitions

includes direct, indirect and incidental investment

FRANCE - MONTREAL 1985-1990

INDUSTRY SECTORS

TOTAL ASSETS

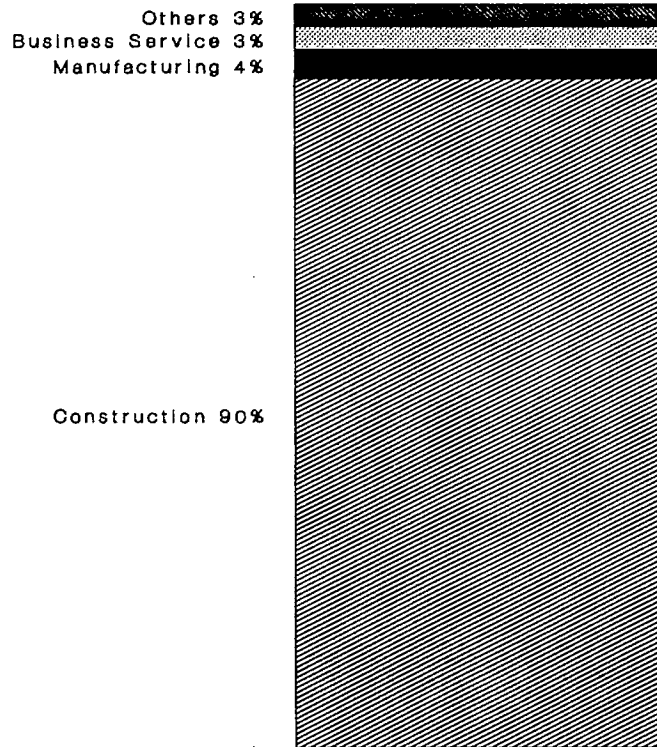

New Business
direct investment only

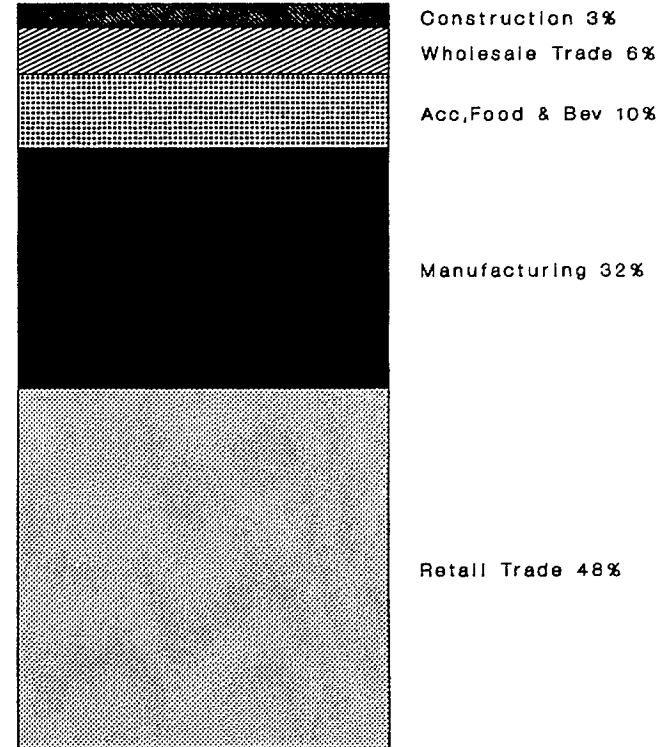

Acquisitions

FRANCE - MONTREAL 1985-1990

INDUSTRY SECTORS

TOTAL FREQUENCIES

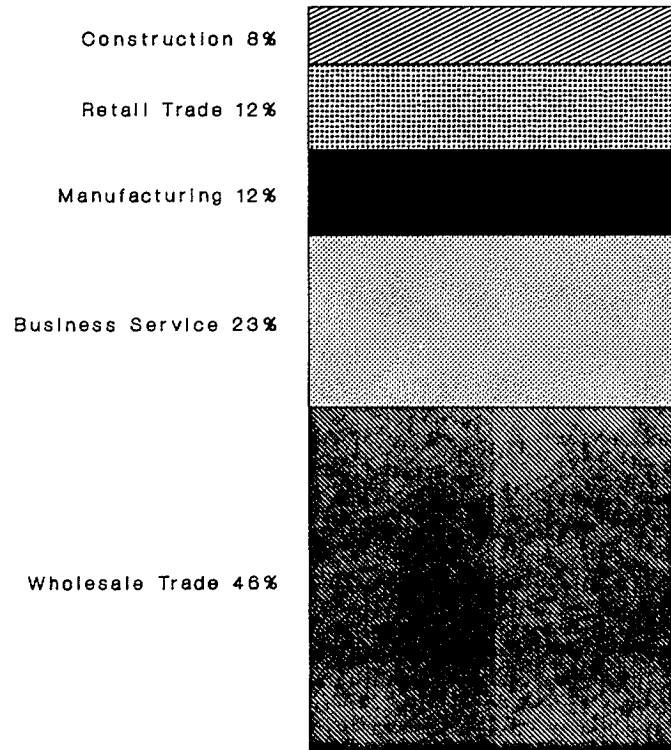

New Business
direct investment only

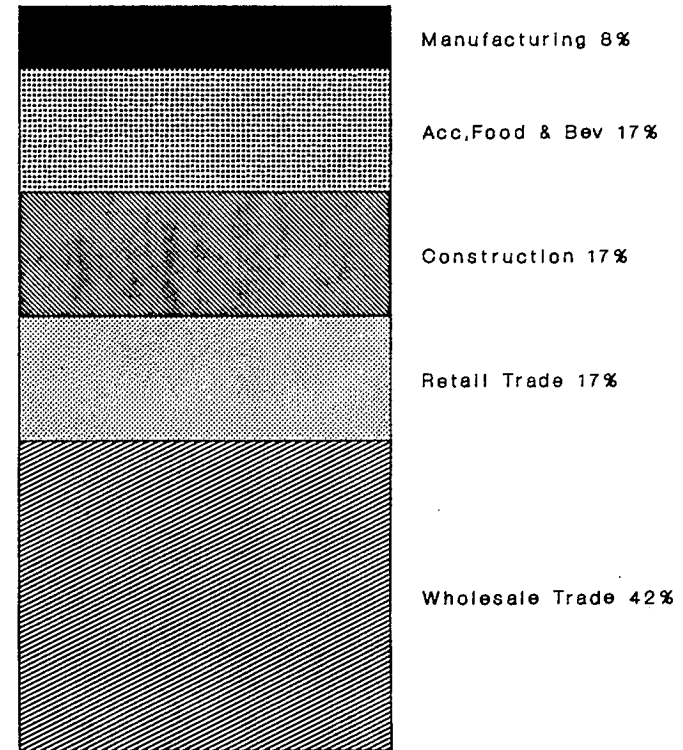

Acquisitions

FRANCE - TORONTO 1985-1990 COMPARISON WITH ONTARIO

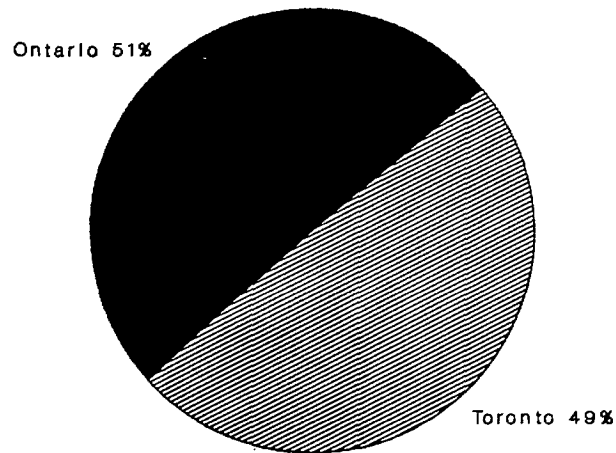

TOTAL ASSETS

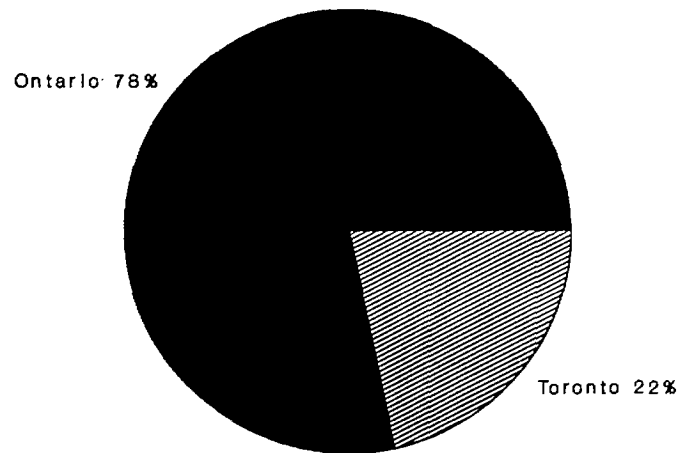

TOTAL FREQUENCIES

includes direct, indirect and incidental investment

FRANCE - TORONTO 1985-1990 COMPARISON WITH ONTARIO

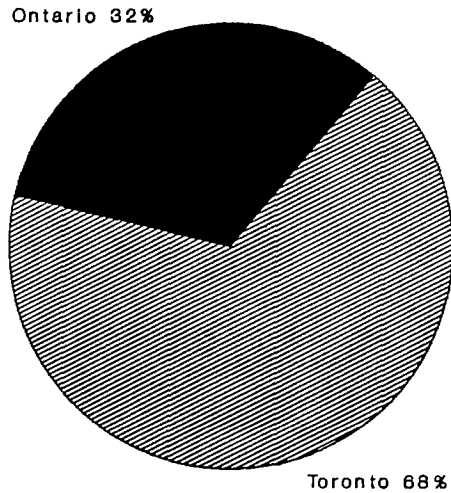

TOTAL ASSETS

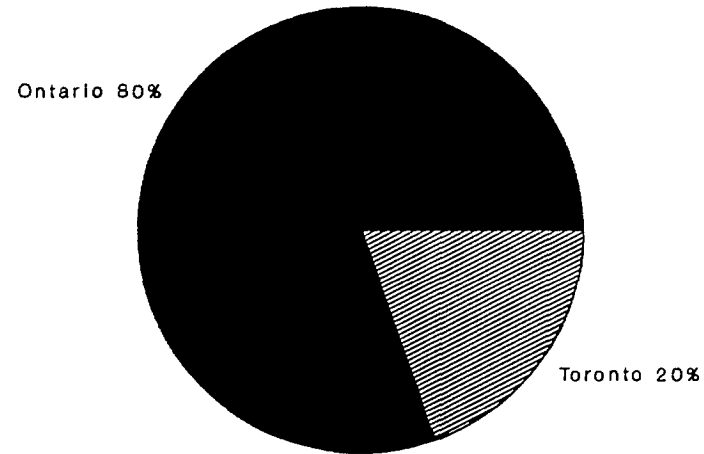

TOTAL FREQUENCIES

direct investment only

FRANCE - TORONTO 1985-1990

TYPES OF INVESTMENT

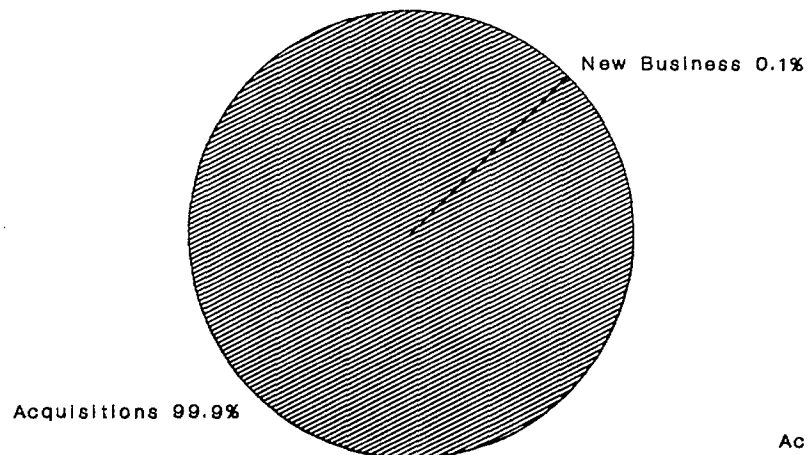

Total Assets

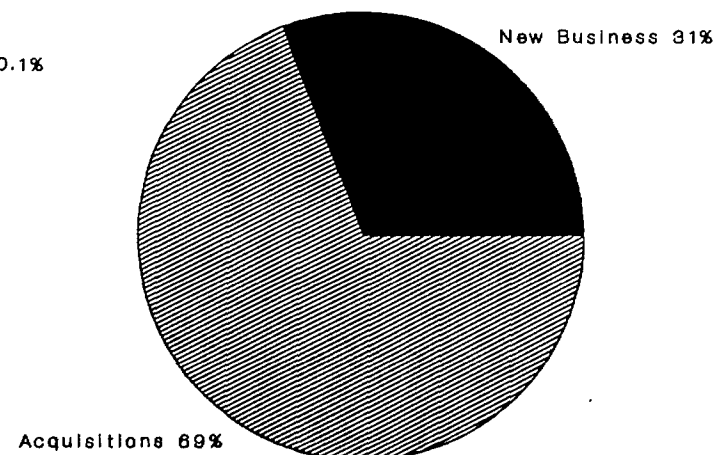

Total Frequencies

includes direct, indirect and incidental investment

FRANCE - TORONTO 1985-1990

TYPES OF INVESTMENT

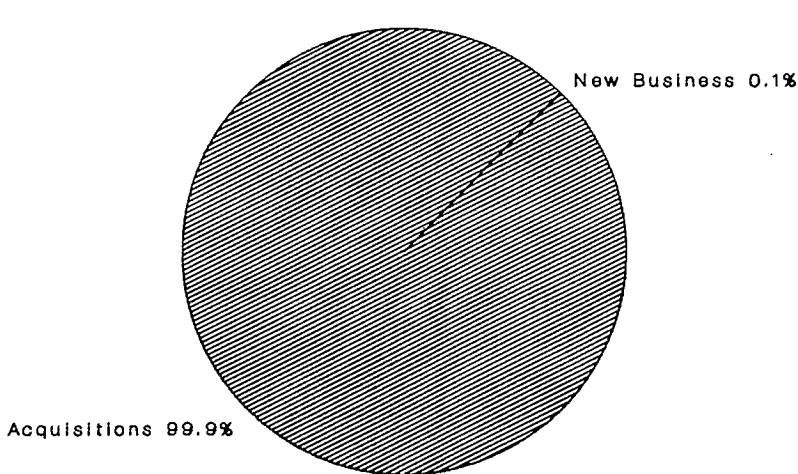

Total Assets

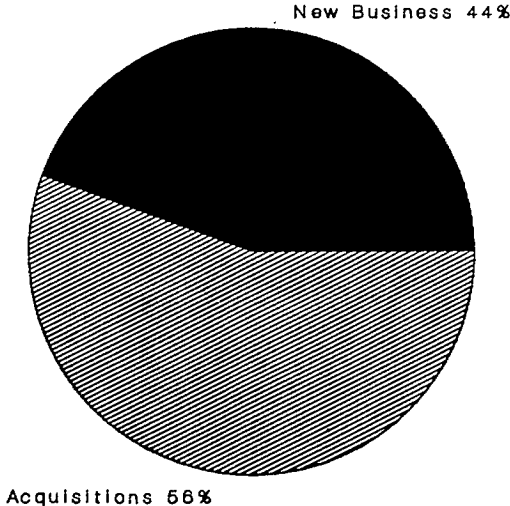

Total Frequencies

direct investment only

FRANCE - TORONTO 1985-1990

INDUSTRY SECTORS

TOTAL ASSETS

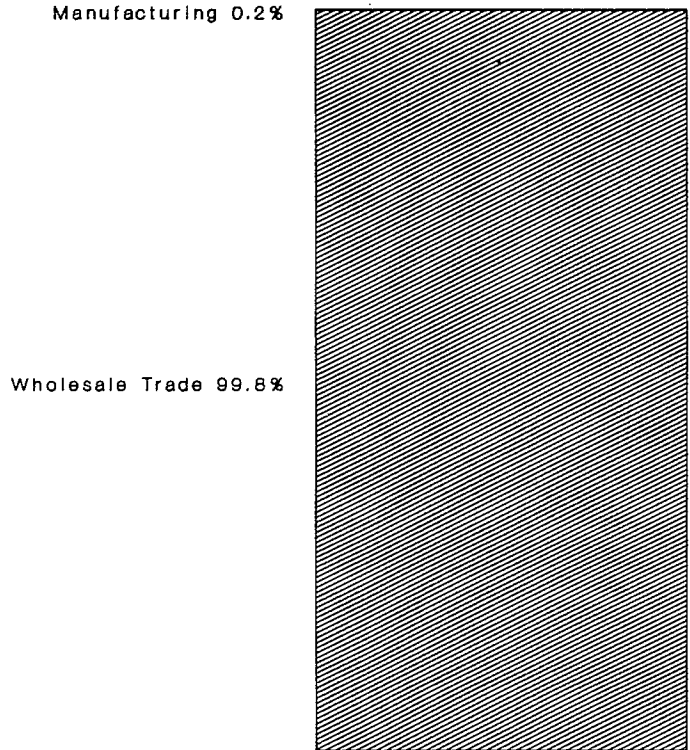

New Business

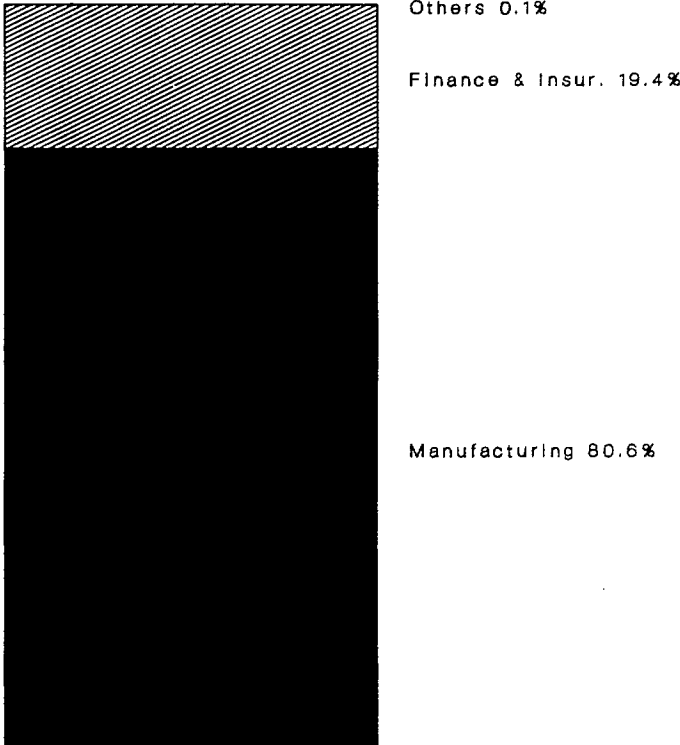

Acquisitions

includes direct, indirect and incidental investment

FRANCE - TORONTO 1985-1990 INDUSTRY SECTORS TOTAL FREQUENCIES

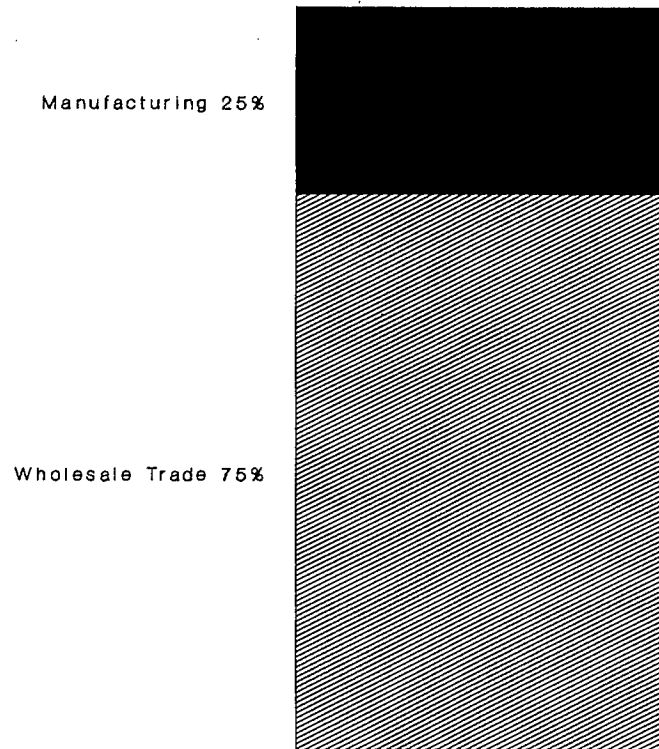

New Business

includes direct, indirect and incidental investment

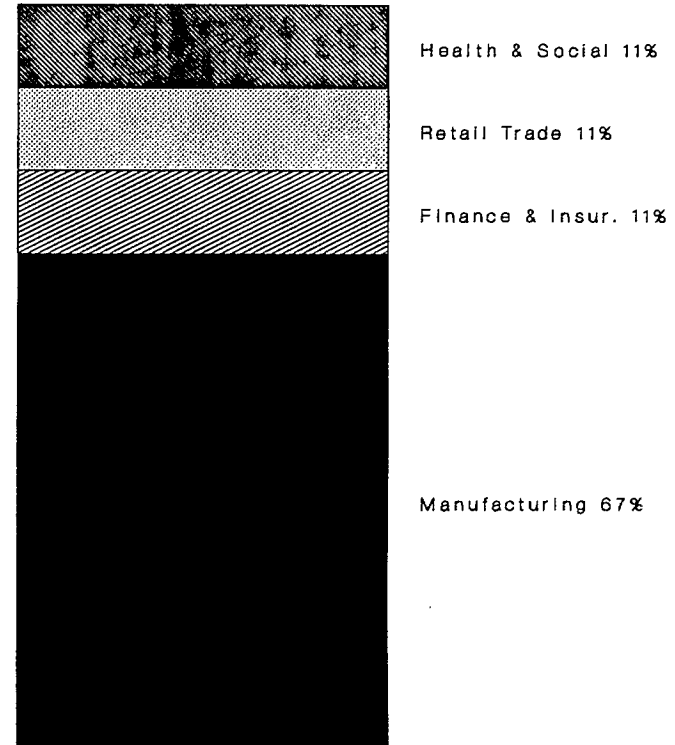

Acquisitions

FRANCE - TORONTO 1985-1990

INDUSTRY SECTORS

TOTAL ASSETS

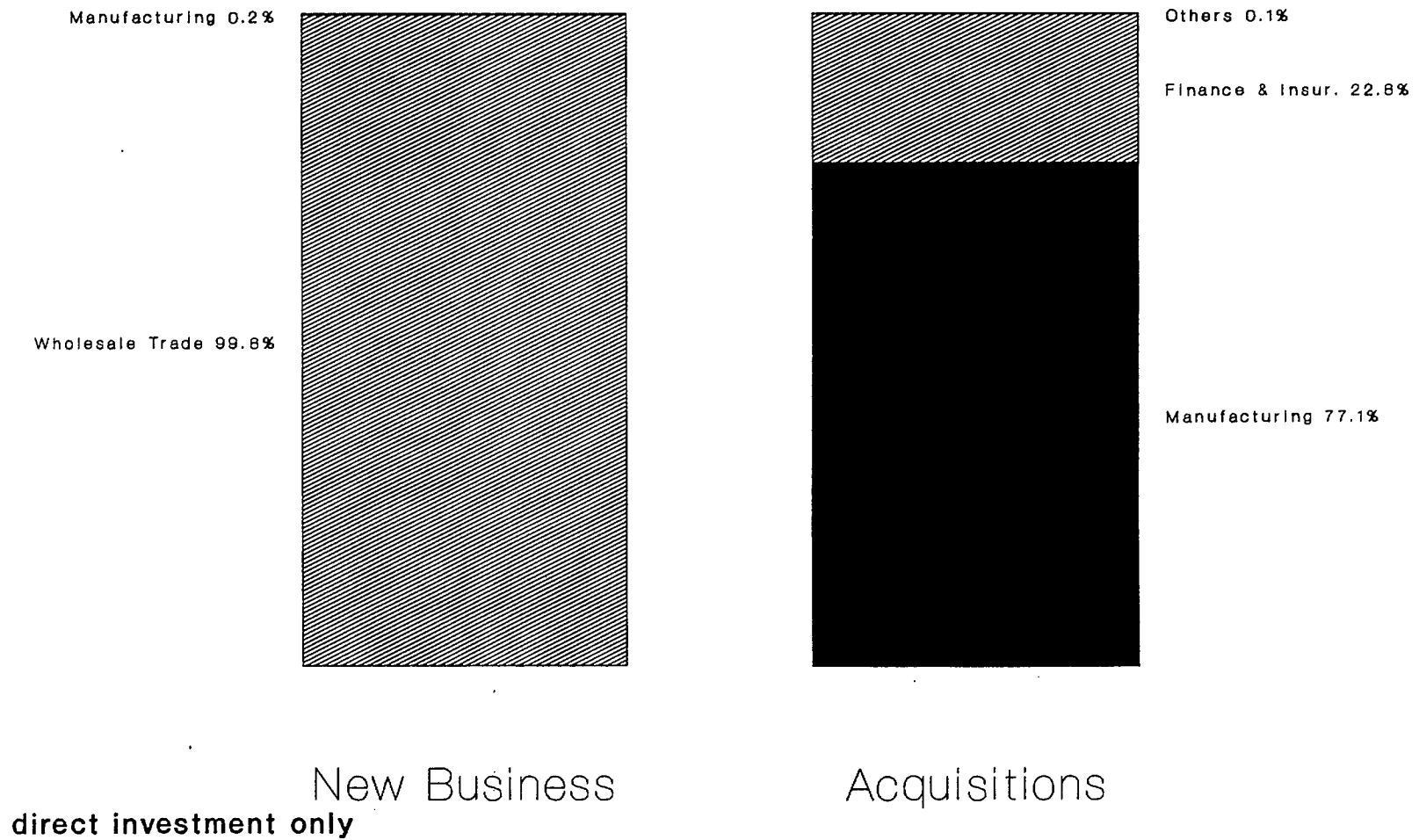

FRANCE - TORONTO 1985-1990

INDUSTRY SECTORS

TOTAL FREQUENCIES

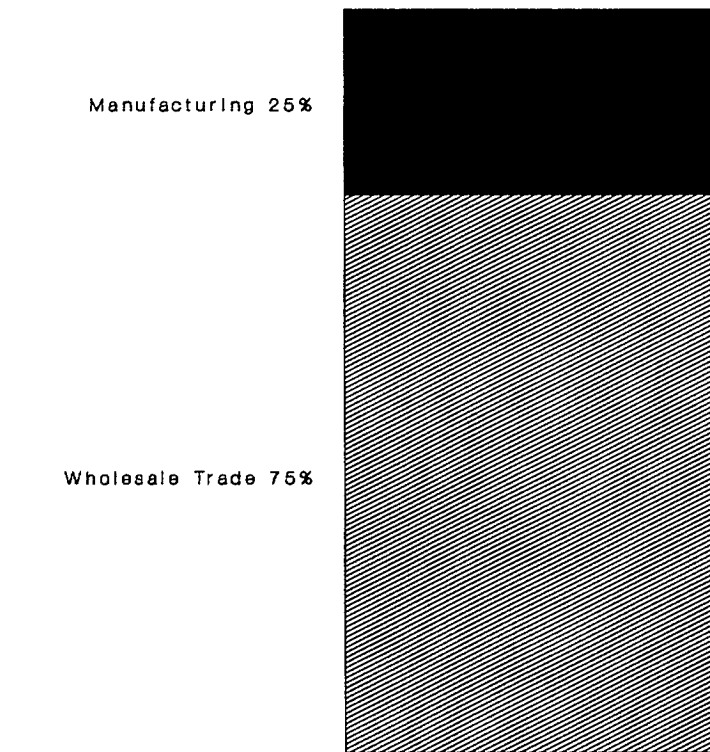

New Business
direct investment only

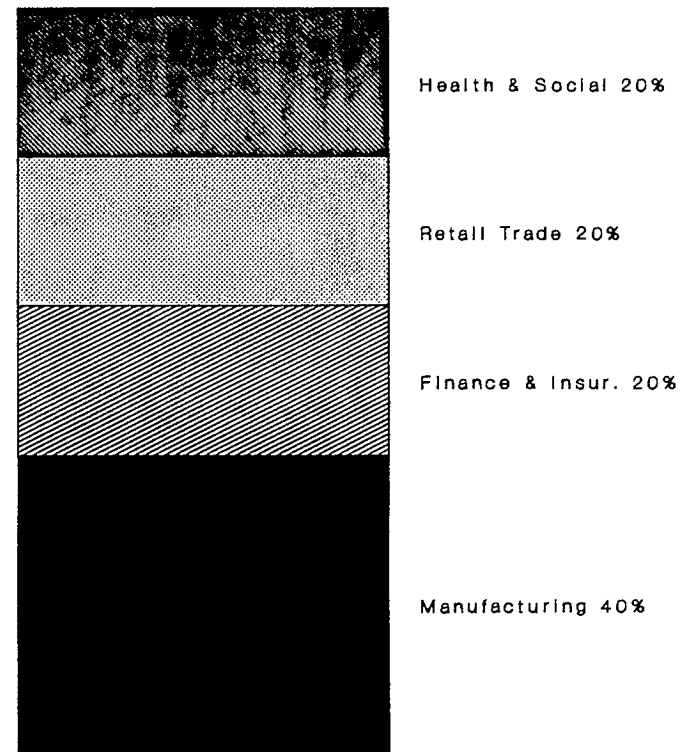

Acquisitions

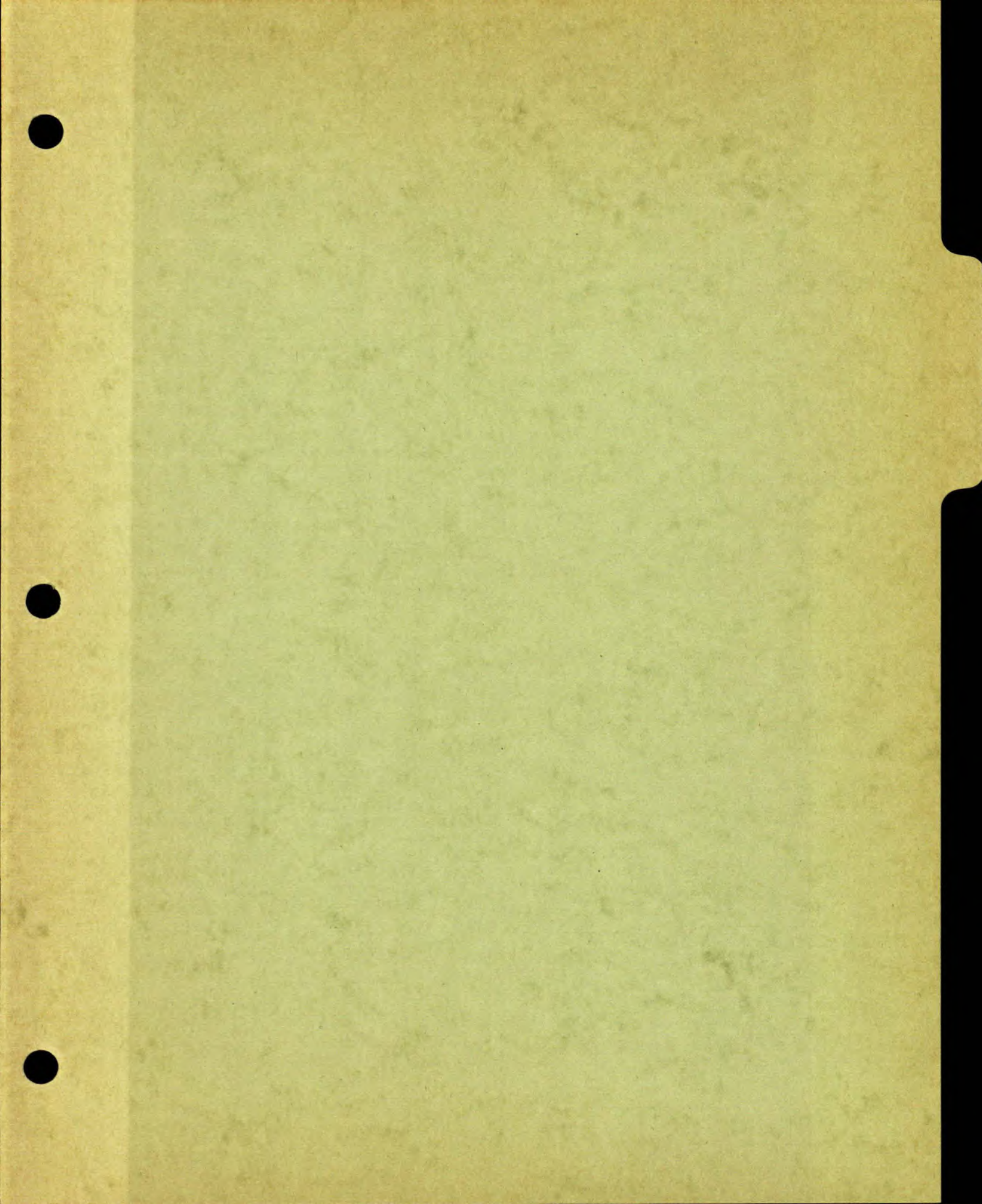

FRANCE - CALGARY 1985-1990 COMPARISON WITH ALBERTA

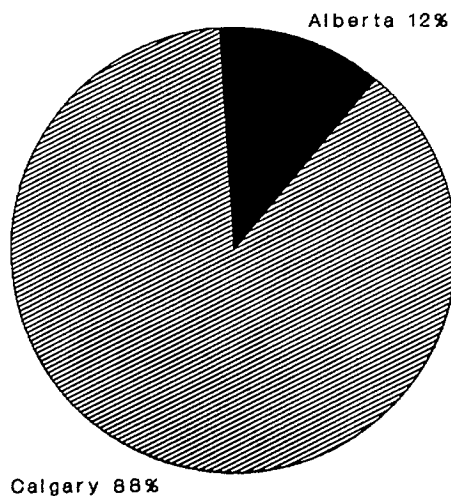

TOTAL ASSETS

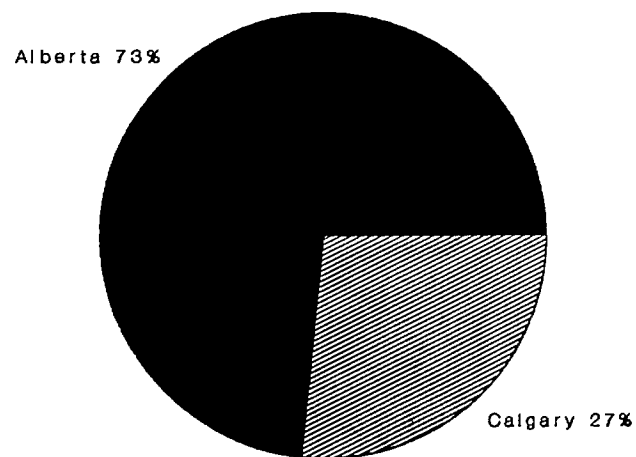

TOTAL FREQUENCIES

includes direct, indirect and incidental investment

FRANCE - CALGARY 1985-1990 COMPARISON WITH ALBERTA

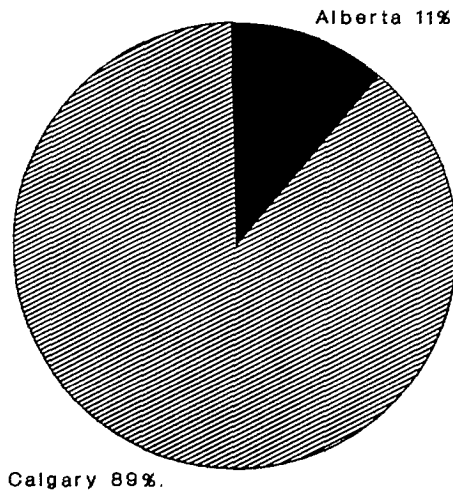

Calgary 89%

Alberta 11%

TOTAL ASSETS

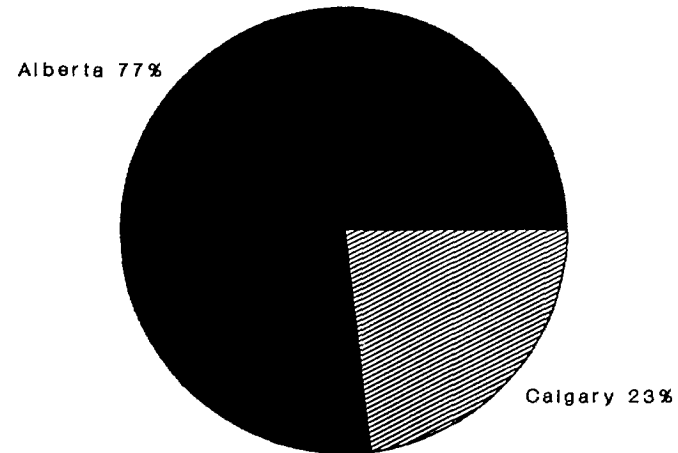

Alberta 77%

Calgary 23%

TOTAL FREQUENCIES

direct investment only

FRANCE - CALGARY 1985-1990 INDUSTRY SECTORS TOTAL ASSETS

Business Service 2%



Wholesale Trade 98%

Direct, Indirect & Incidental

Business Service 2%



Wholesale Trade 98%

Direct

All investment transactions were acquisitions.

FRANCE - CALGARY 1985-1990

INDUSTRY SECTORS

TOTAL FREQUENCIES

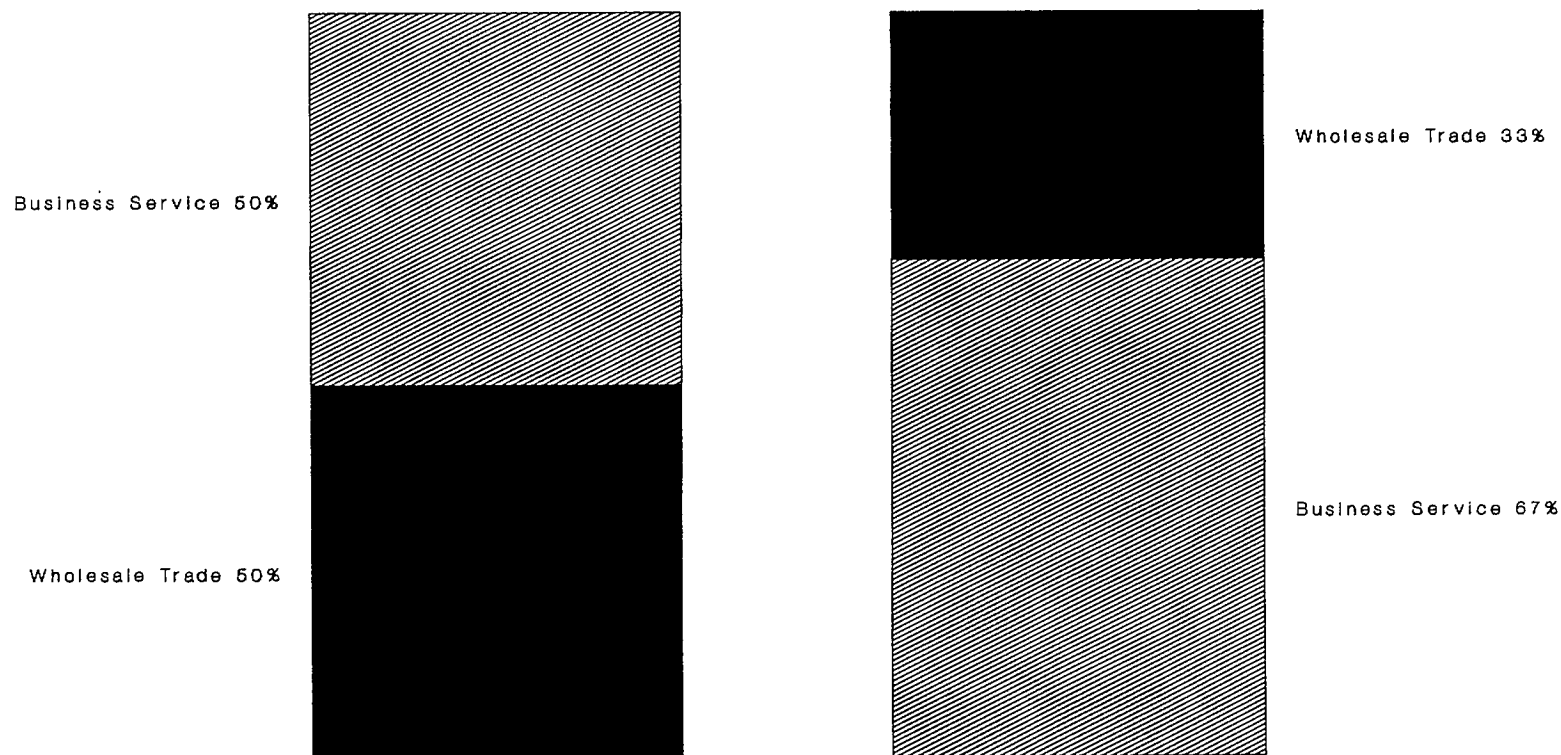

Direct, Indirect & Incidental

Direct

All investment transactions were acquisitions.

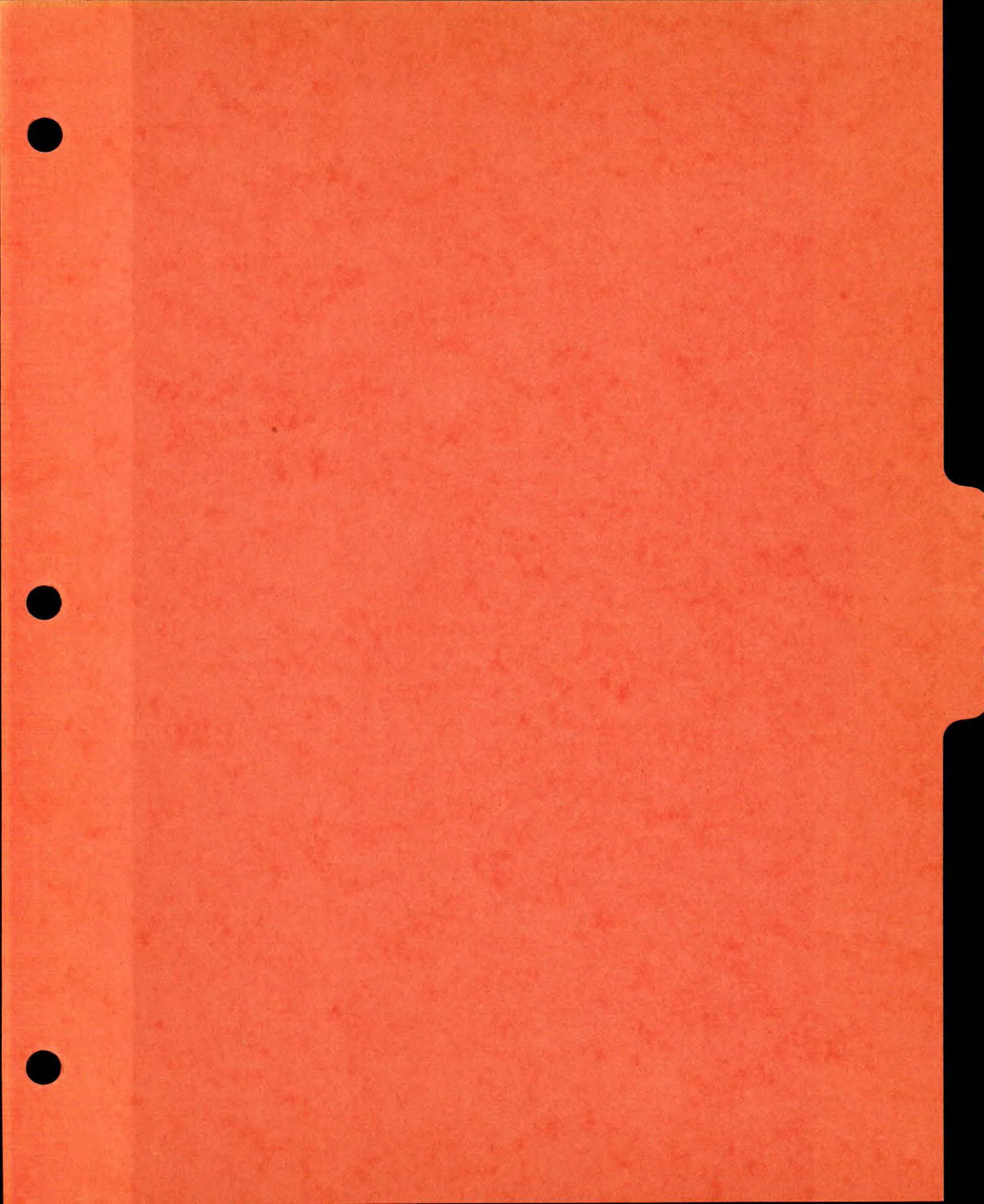

FRANCE - VANCOUVER 1985-1990 COMPARISON WITH BRITISH COLUMBIA



TOTAL ASSETS

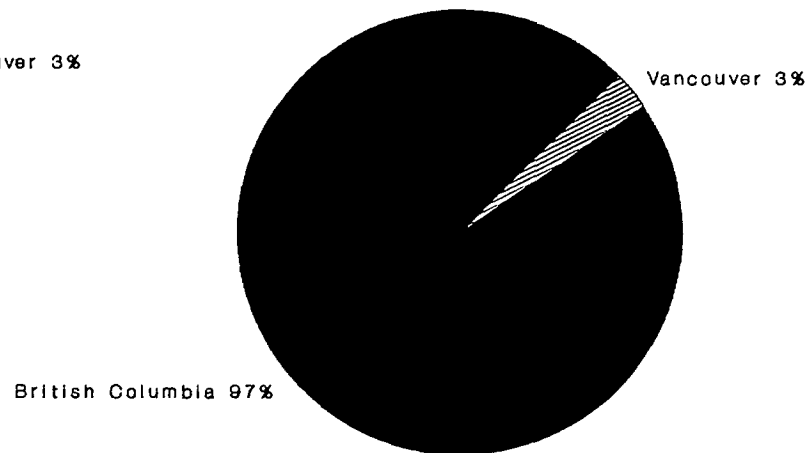

TOTAL FREQUENCIES

Only direct investment was made.

FRANCE - VANCOUVER 1985-1990 INDUSTRY SECTORS

Wholesale Trade 100%



Total Assets (000's)

Only two investment transactions,
both direct acquisitions occurred.

Wholesale Trade 100%



Total Frequencies



France

CANADA:
(including indirect and incidental investment)

Sector:	Asset Value:			% of Tot. Asset Value			Frequency:			% of Tot. Frequency:		
	New:	Acqu.:	Tot.	New:	Acqu.:	Tot:	New:	Acqu.:	Tot.	New:	Acqu.:	Tot.
Manufacturing	9531	1619008	1628539	5.56	40.67	39.22	14	51	65	21.88	39.84	33.85
Construction	45000	0	45000	26.26	0.00	1.08	2	0	2	3.13	0.00	1.04
Retail Trade	860	113168	114028	0.50	2.84	2.75	5	8	13	7.81	6.25	6.77
Agriculture	0	458	458	0.00	0.01	0.01	0	1	1	0.00	0.78	0.52
Logging & Forestry	0	0	0	0.00	0.00	0.00	0	0	0	0.00	0.00	0.00
Fishing & Trapping	0	0	0	0.00	0.00	0.00	0	0	0	0.00	0.00	0.00
Mining	10	273668	273678	0.01	6.87	6.59	1	10	11	1.56	7.81	5.73
Petro & Natural Gas	15000	55674	70674	8.75	1.40	1.70	1	3	4	1.56	2.34	2.08
Wholesale Trade	4989	1664231	1669220	2.91	41.81	40.20	24	42	66	37.50	32.81	34.38
Transport. & Storage	0	0	0	0.00	0.00	0.00	0	0	0	0.00	0.00	0.00
Real Estate & Ins. Agents	0	31844	31844	0.00	0.80	0.77	0	3	3	0.00	2.34	1.56
Finance & Insurance	1	170436	170437	0.00	4.28	4.10	1	1	2	1.56	0.78	1.04
Acc., Food & Beverages	23050	22434	45484	13.45	0.56	1.10	1	3	4	1.56	2.34	2.08
Business Service	71892	16608	88500	41.96	0.42	2.13	14	4	18	21.88	3.13	9.38
Education Service	0	0	0	0.00	0.00	0.00	0	0	0	0.00	0.00	0.00
Health & Social Service:	0	325	325	0.00	0.01	0.01	0	1	1	0.00	0.78	0.52
Other service	1000	12775	13775	0.58	0.32	0.33	1	1	2	1.56	0.78	1.04
Total:	171333	3980629	4151962	100	100	100	64	128	192	100	100	100

France

CANADA:
(excluding indirect and incidental investment)

Sector:	Asset Value:			% of Tot. Asset Value			Frequency:			% of Tot. Frequency:		
	New:	Acqu.:	Tot.	New:	Acqu.:	Tot:	New:	Acqu.:	Tot.	New:	Acqu.:	Tot.
Manufacturing	9531	926602	936133	5.56	30.31	29.00	14	37	51	21.88	34.91	30.00
Construction	45000	0	45000	26.26	0.00	1.39	2	0	2	3.13	0.00	1.18
Retail Trade	860	113168	114028	0.50	3.70	3.53	5	8	13	7.81	7.55	7.65
Agriculture	0	0	0	0.00	0.00	0.00	0	0	0	0.00	0.00	0.00
Logging & Forestry	0	0	0	0.00	0.00	0.00	0	0	0	0.00	0.00	0.00
Fishing & Trapping	0	0	0	0.00	0.00	0.00	0	0	0	0.00	0.00	0.00
Mining	10	86637	86647	0.01	2.83	2.68	1	8	9	1.56	7.55	5.29
Petro & Natural Gas	15000	55674	70674	8.75	1.82	2.19	1	3	4	1.56	2.83	2.35
Wholesale Trade	4989	1623874	1628863	2.91	53.12	50.46	24	38	62	37.50	35.85	36.47
Transport. & Storage	0	0	0	0.00	0.00	0.00	0	0	0	0.00	0.00	0.00
Real Estate & Ins. Agents	0	31844	31844	0.00	1.04	0.99	0	3	3	0.00	2.83	1.76
Finance & Insurance	1	170436	170437	0.00	5.58	5.28	1	1	2	1.56	0.94	1.18
Acc., Food & Beverages	23050	22434	45484	13.45	0.73	1.41	1	3	4	1.56	2.83	2.35
Business Service	71892	13246	85138	41.96	0.43	2.64	14	3	17	21.88	2.83	10.00
Education Service	0	0	0	0.00	0.00	0.00	0	0	0	0.00	0.00	0.00
Health & Social Service	0	325	325	0.00	0.01	0.01	0	1	1	0.00	0.94	0.59
Other service	1000	12775	13775	0.58	0.42	0.43	1	1	2	1.56	0.94	1.18
Total:	171333	3057015	3228348	100.00	100.00	100.00	64	106	170	100	100	100

France

ONTARIO:
(including indirect and incidental investment)

Sector:	Asset Value: (000's)			% of Tot. ONT Asset Value			% of Tot. CDN Asset Value:			Frequency:			% of Tot. ONT Frequency:		
	New:	Acqu.:	Tot:	New:	Acqu.:	Tot:	New:	Acqu.:	Tot:	New:	Acqu.:	Tot:	New:	Acqu.:	Tot:
Manufacturing	501	1339874	1340375	1.93	76.13	75.05	5.26	82.76	82.31	2	26	28	3.33	43.33	46.67
Construction	0	0	0	0.00	0.00	0.00	0.00	0.00	0.00	0	0	0	0.00	0.00	0.00
Retail Trade	0	5264	5264	0.00	0.30	0.29	0.00	4.65	4.62	0	3	3	0.00	5.00	5.00
Agriculture	0	458	458	0.00	0.03	0.03	0.00	100.00	100.00	0	1	1	0.00	1.67	1.67
Logging & Forestry	0	0	0	0.00	0.00	0.00	0.00	0.00	0.00	0	0	0	0.00	0.00	0.00
Fishing & Trapping	0	0	0	0.00	0.00	0.00	0.00	0.00	0.00	0	0	0	0.00	0.00	0.00
Mining	0	28061	28061	0.00	1.59	1.57	0.00	10.25	10.25	0	4	4	0.00	6.67	6.67
Petro & Natural Gas	0	0	0	0.00	0.00	0.00	0.00	0.00	0.00	0	0	0	0.00	0.00	0.00
Wholesale Trade	2447	215434	217881	9.41	12.24	12.20	49.05	12.94	13.05	8	12	20	13.33	20.00	33.33
Transport. & Storage	0	0	0	0.00	0.00	0.00	0.00	0.00	0.00	0	0	0	0.00	0.00	0.00
Real Estate & Ins. Agents	0	59	59	0.00	0.00	0.00	0.00	0.19	0.19	0	1	1	0.00	1.67	1.67
Finance & Insurance	0	170436	170436	0.00	9.68	9.54	0.00	100.00	100.00	0	1	1	0.00	1.67	1.67
Acc., Food & Beverages	23050	0	23050	88.66	0.00	1.29	100.00	0.00	50.68	1	0	1	1.67	0.00	1.67
Business Service	0	0	0	0.00	0.00	0.00	0.00	0.00	0.00	0	0	0	0.00	0.00	0.00
Education Service	0	0	0	0.00	0.00	0.00	0.00	0.00	0.00	0	0	0	0.00	0.00	0.00
Health & Social Service	0	325	325	0.00	0.02	0.02	0.00	100.00	100.00	0	1	1	0.00	1.67	1.67
Other service	0	0	0	0.00	0.00	0.00	0.00	0.00	0.00	0	0	0	0.00	0.00	0.00
Total:	25998	1759911	1785909	100	100	100	15.17	44.21	43.01	11	49	60	18.33	81.67	100.00

France

ONTARIO:
(excluding indirect and incidental investment)

Sector:	Asset Value:			% of Tot. ONT Asset Value			% of Tot. CDN Asset Value:			Frequency:			% of Tot. ONT Frequency:		
	New:	Acqu.:	Tot:	New:	Acqu.:	Tot:	New:	Acqu.:	Tot:	New:	Acqu.:	Tot:	New:	Acqu.:	Tot:
Manufacturing	501	665215	665716	1.93	61.54	60.14	5.26	71.79	71.11	2	14	16	4.35	30.43	34.78
Construction	0	0	0	0.00	0.00	0.00	0.00	0.00	0.00	0	0	0	0.00	0.00	0.00
Retail Trade	0	5264	5264	0.00	0.49	0.48	0.00	4.65	4.62	0	3	3	0.00	6.52	6.52
Agriculture	0	0	0	0.00	0.00	0.00	0.00	0.00	0.00	0	0	0	0.00	0.00	0.00
Logging & Forestry	0	0	0	0.00	0.00	0.00	0.00	0.00	0.00	0	0	0	0.00	0.00	0.00
Fishing & Trapping	0	0	0	0.00	0.00	0.00	0.00	0.00	0.00	0	0	0	0.00	0.00	0.00
Mining	0	28061	28061	0.00	2.60	2.53	0.00	32.39	32.39	0	4	4	0.00	8.70	8.70
Petro & Natural Gas	0	0	0	0.00	0.00	0.00	0.00	0.00	0.00	0	0	0	0.00	0.00	0.00
Wholesale Trade	2447	211614	214061	9.41	19.58	19.34	49.05	13.03	13.14	8	11	19	17.39	23.91	41.30
Transport. & Storage	0	0	0	0.00	0.00	0.00	0.00	0.00	0.00	0	0	0	0.00	0.00	0.00
Real Estate & Ins. Agents	0	59	59	0.00	0.01	0.01	0.00	0.19	0.19	0	1	1	0.00	2.17	2.17
Finance & Insurance	0	170436	170436	0.00	15.77	15.40	0.00	100.00	100.00	0	1	1	0.00	2.17	2.17
Acc., Food & Beverages	23050	0	23050	88.66	0.00	2.08	100.00	0.00	50.68	1	0	1	2.17	0.00	2.17
Business Service	0	0	0	0.00	0.00	0.00	0.00	0.00	0.00	0	0	0	0.00	0.00	0.00
Education Service	0	0	0	0.00	0.00	0.00	0.00	0.00	0.00	0	0	0	0.00	0.00	0.00
Health & Social Service	0	325	325	0.00	0.03	0.03	0.00	100.00	100.00	0	1	1	0.00	2.17	2.17
Other service	0	0	0	0.00	0.00	0.00	0.00	0.00	0.00	0	0	0	0.00	0.00	0.00
Total:	25998	1080974	1106972	100	100	100	15.17	35.36	34.29	11	35	46	23.91	76.09	100.00

France

QUEBEC:
(including indirect and incidental investment)

Sector:	Asset Value: (000's)			% of Tot. QUE Asset Value			% of Tot. CDN Asset Value:			Frequency:			% of Tot. Frequency:		
	New:	Acqu.:	Tot:	New:	Acqu.:	Tot:	New:	Acqu.:	Tot:	New:	Acqu.:	Tot:	New:	Acqu.:	Tot:
Manufacturing	9030	264228	273258	14.97	23.50	23.06	94.74	16.32	16.78	12	14	26	12.00	14.00	26.00
Construction	45000	0	45000	74.58	0.00	3.80	100.00	0.00	100.00	2	0	2	2.00	0.00	2.00
Retail Trade	860	107804	108664	1.43	9.59	9.17	100.00	95.26	95.30	5	4	9	5.00	4.00	9.00
Agriculture	0	0	0	0.00	0.00	0.00	0.00	0.00	0.00	0	0	0	0.00	0.00	0.00
Logging & Forestry	0	0	0	0.00	0.00	0.00	0.00	0.00	0.00	0	0	0	0.00	0.00	0.00
Fishing & Trapping	0	0	0	0.00	0.00	0.00	0.00	0.00	0.00	0	0	0	0.00	0.00	0.00
Mining	10	0	10	0.02	0.00	0.00	100.00	0.00	0.00	1	0	1	1.00	0.00	1.00
Petro & Natural Gas	0	0	0	0.00	0.00	0.00	0.00	0.00	0.00	0	0	0	0.00	0.00	0.00
Wholesale Trade	2542	709481	712023	4.21	63.10	60.10	50.95	42.63	42.66	16	24	40	16.00	24.00	40.00
Transport. & Storage	0	0	0	0.00	0.00	0.00	0.00	0.00	0.00	0	0	0	0.00	0.00	0.00
Real Estate & Ins. Agents	0	4100	4100	0.00	0.36	0.35	0.00	12.88	12.88	0	1	1	0.00	1.00	1.00
Finance & Insurance	1	0	1	0.00	0.00	0.00	100.00	0.00	0.00	1	0	1	1.00	0.00	1.00
Acc., Food & Beverages	0	22434	22434	0.00	2.00	1.89	0.00	100.00	49.32	0	3	3	0.00	3.00	3.00
Business Service	1892	3582	5474	3.14	0.32	0.46	2.63	21.57	6.19	13	2	15	13.00	2.00	15.00
Education Service	0	0	0	0.00	0.00	0.00	0.00	0.00	0.00	0	0	0	0.00	0.00	0.00
Other service	1000	12775	13775	1.66	1.14	1.16	100.00	100.00	100.00	1	1	2	1.00	1.00	2.00
Total:	60335	1124404	1184739	100	100	100	35.22	28.25	28.53	51	49	100	51	49	100.00
										100			100		

France

QUEBEC:
(excluding indirect and incidental investment)

Sector:	Asset Value: (000's)			% of Tot. QUE Asset Value			% of Tot. CDN Asset Value:			Frequency:			% of Tot. Frequency:		
	New:	Acqu.:	Tot:	New:	Tot:		New:	Acqu.:	Tot:	New:	Acqu.:	Tot:	New:	Acqu.:	Tot:
Manufacturing	9030	246481	255511	14.97	22.82	22.40	94.74	26.60	27.29	12	12	24	12.63	12.63	25.26
Construction	45000	0	45000	74.58	0.00	3.95	100.00	0.00	100.00	2	0	2	2.11	0.00	2.11
Retail Trade	860	107804	108664	1.43	9.98	9.53	100.00	95.26	95.30	5	4	9	5.26	4.21	9.47
Agriculture	0	0	0	0.00	0.00	0.00	0.00	0.00	0.00	0	0	0	0.00	0.00	0.00
Logging & Forestry	0	0	0	0.00	0.00	0.00	0.00	0.00	0.00	0	0	0	0.00	0.00	0.00
Fishing & Trapping	0	0	0	0.00	0.00	0.00	0.00	0.00	0.00	0	0	0	0.00	0.00	0.00
Mining	10	0	10	0.02	0.00	0.00	100.00	0.00	0.01	1	0	1	1.05	0.00	1.05
Petro & Natural Gas	0	0	0	0.00	0.00	0.00	0.00	0.00	0.00	0	0	0	0.00	0.00	0.00
Wholesale Trade	2542	686281	688823	4.21	63.54	60.40	50.95	42.26	42.29	16	22	38	16.84	23.16	40.00
Transport. & Storage	0	0	0	0.00	0.00	0.00	0.00	0.00	0.00	0	0	0	0.00	0.00	0.00
Real Estate & Ins. Agents	0	4100	4100	0.00	0.38	0.36	0.00	12.88	12.88	0	1	1	0.00	1.05	1.05
Finance & Insurance	1	0	1	0.00	0.00	0.00	100.00	0.00	0.00	1	0	1	1.05	0.00	1.05
Acc., Food & Beverages	0	22434	22434	0.00	2.08	1.97	0.00	100.00	49.32	0	3	3	0.00	3.16	3.16
Business Service	1892	220	2112	3.14	0.02	0.19	2.63	1.66	2.48	13	1	14	13.68	1.05	14.74
Education Service	0	0	0	0.00	0.00	0.00	0.00	0.00	0.00	0	0	0	0.00	0.00	0.00
Other service	1000	12775	13775	1.66	1.18	1.21	100.00	100.00	100.00	1	1	2	1.05	1.05	2.11
Total:	60335	1080095	1140430	100	100	100	35.22	35.33	35.33	51	44	95	53.68	46.32	100.00

France

BRITISH COLUMBIA:
(no indirect or incidental investment made)

Sector:	Asset Value: (000's)			% of Tot. B.C. Asset Value			% of Tot. CDN Asset Value:			Frequency:			% of Tot. Frequency:		
	New:	Acqu.:	Tot:	New:	Acqu.:	Tot:	New:	Acqu.:	Tot:	New:	Acqu.:	Tot:	New:	Acqu.:	Tot:
Manufacturing	0	9251	9251	0.00	7.02	6.30	0.00	0.57	0.57	0	5	5	0.00	38.46	38.46
Construction	0	0	0	0.00	0.00	0.00	0.00	0.00	0.00	0	0	0	0.00	0.00	0.00
Retail Trade	0	0	0	0.00	0.00	0.00	0.00	0.00	0.00	0	0	0	0.00	0.00	0.00
Agriculture	0	0	0	0.00	0.00	0.00	0.00	0.00	0.00	0	0	0	0.00	0.00	0.00
Logging & Forestry	0	0	0	0.00	0.00	0.00	0.00	0.00	0.00	0	0	0	0.00	0.00	0.00
Fishing & Trapping	0	0	0	0.00	0.00	0.00	0.00	0.00	0.00	0	0	0	0.00	0.00	0.00
Mining	0	56501	56501	0.00	42.89	38.51	0.00	20.65	20.65	0	3	3	0.00	23.08	23.08
Petro & Natural Gas	15000	0	15000	100.00	0.00	10.22	100.00	0.00	21.22	1	0	1	7.69	0.00	7.69
Wholesale Trade	0	65979	65979	0.00	50.09	44.97	0.00	3.96	3.95	0	4	4	0.00	30.77	30.77
Transport. & Storage	0	0	0	0.00	0.00	0.00	0.00	0.00	0.00	0	0	0	0.00	0.00	0.00
Real Estate & Ins. Agents	0	0	0	0.00	0.00	0.00	0.00	0.00	0.00	0	0	0	0.00	0.00	0.00
Finance & Insurance	0	0	0	0.00	0.00	0.00	0.00	0.00	0.00	0	0	0	0.00	0.00	0.00
Acc., Food & Beverages	0	0	0	0.00	0.00	0.00	0.00	0.00	0.00	0	0	0	0.00	0.00	0.00
Business Service	0	0	0	0.00	0.00	0.00	0.00	0.00	0.00	0	0	0	0.00	0.00	0.00
Education Service	0	0	0	0.00	0.00	0.00	0.00	0.00	0.00	0	0	0	0.00	0.00	0.00
Other service	0	0	0	0.00	0.00	0.00	0.00	0.00	0.00	0	0	0	0.00	0.00	0.00
Total:	15000	131731	146731	100	100	100	8.75	3.31	3.53	1	12	13	7.69	92.31	100.00

France

Total for Atlantic Provinces is the investment made in Nova Scotia.

NOVA SCOTIA:

Sector:	Asset Value: (000's)			% of Tot. Asset Value			% of Tot. CDN Asset Value:			Frequency:			% of Tot. Frequency:		
	New:	Acqu.:	Tot:	New:	Acqu.:	Tot:	New:	Acqu.:	Tot:	New:	Acqu.:	Tot:	New:	Acqu.:	Tot:
Manufacturing	0	0	0	0.00	0.00	0.00	0.00	0.00	0.00	0	0	0	0.00	0.00	0.00
Construction	0	0	0	0.00	0.00	0.00	0.00	0.00	0.00	0	0	0	0.00	0.00	0.00
Retail Trade	0	0	0	0.00	0.00	0.00	0.00	0.00	0.00	0	0	0	0.00	0.00	0.00
Agriculture	0	0	0	0.00	0.00	0.00	0.00	0.00	0.00	0	0	0	0.00	0.00	0.00
Logging & Forestry	0	0	0	0.00	0.00	0.00	0.00	0.00	0.00	0	0	0	0.00	0.00	0.00
Fishing & Trapping	0	0	0	0.00	0.00	0.00	0.00	0.00	0.00	0	0	0	0.00	0.00	0.00
Mining	0	0	0	0.00	0.00	0.00	0.00	0.00	0.00	0	0	0	0.00	0.00	0.00
Petro & Natural Gas	0	0	0	0.00	0.00	0.00	0.00	0.00	0.00	0	0	0	0.00	0.00	0.00
Wholesale Trade	0	0	0	0.00	0.00	0.00	0.00	0.00	0.00	0	0	0	0.00	0.00	0.00
Transport. & Storage	0	0	0	0.00	0.00	0.00	0.00	0.00	0.00	0	0	0	0.00	0.00	0.00
Real Estate & Ins. Agents	0	0	0	0.00	0.00	0.00	0.00	0.00	0.00	0	0	0	0.00	0.00	0.00
Finance & Insurance	0	0	0	0.00	0.00	0.00	0.00	0.00	0.00	0	0	0	0.00	0.00	0.00
Acc., Food & Beverages	0	0	0	0.00	0.00	0.00	0.00	0.00	0.00	0	0	0	0.00	0.00	0.00
Business Service	70000	0	70000	100.00	0.00	100.00	97.37	0.00	79.10	1	0	1	100.00	0.00	100.00
Education Service	0	0	0	0.00	0.00	0.00	0.00	0.00	0.00	0	0	0	0.00	0.00	0.00
Other service	0	0	0	0.00	0.00	0.00	0.00	0.00	0.00	0	0	0	0.00	0.00	0.00
Total:	70000	0	70000	0.00	0.00	100	40.86	0.00	1.69	1	0	1	100.00	0.00	100.00

France

PRAIRIE PROVINCES:

(including direct, indirect, and incidental investment made)

Sector:	Asset Value: (000's)			% of Tot. Asset Value			% of Tot. CDN Asset Value:			Frequency:			% of Tot. Frequency:		
	New:	Acqu.:	Tot:	New:	Acqu.:	Tot:	New:	Acqu.:	Tot:	New:	Acqu.:	Tot:	New:	Acqu.:	Tot:
Manufacturing	0	5655	5655	0.00	0.59	0.59	0.00	0.35	0.35	0	6	6	0.00	33.33	33.33
Construction	0	0	0	0.00	0.00	0.00	0.00	0.00	0.00	0	0	0	0.00	0.00	0.00
Retail Trade	0	100	100	0.00	0.01	0.01	0.00	0.09	0.09	0	1	1	0.00	5.56	5.56
Agriculture	0	0	0	0.00	0.00	0.00	0.00	0.00	0.00	0	0	0	0.00	0.00	0.00
Logging & Forestry	0	0	0	0.00	0.00	0.00	0.00	0.00	0.00	0	0	0	0.00	0.00	0.00
Fishing-& Trapping	0	0	0	0.00	0.00	0.00	0.00	0.00	0.00	0	0	0	0.00	0.00	0.00
Mining	0	189106	189106	0.00	19.60	19.60	0.00	69.10	69.10	0	3	3	0.00	16.67	16.67
Petro & Natural Gas	0	55674	55674	0.00	5.77	5.77	0.00	3.35	3.34	0	3	3	0.00	16.67	16.67
Wholesale Trade	0	673337	673337	0.00	69.81	69.81	0.00	40.46	40.34	0	2	2	0.00	11.11	11.11
Transport. & Storage	0	0	0	0.00	0.00	0.00	0.00	0.00	0.00	0	0	0	0.00	0.00	0.00
Real Estate & Ins. Agents	0	27685	27685	0.00	2.87	2.87	0.00	86.94	86.94	0	1	1	0.00	5.56	5.56
Finance & Insurance	0	0	0	0.00	0.00	0.00	0.00	0.00	0.00	0	0	0	0.00	0.00	0.00
Acc., Food & Beverages	0	0	0	0.00	0.00	0.00	0.00	0.00	0.00	0	0	0	0.00	0.00	0.00
Business Service	0	13026	13026	0.00	1.35	1.35	0.00	78.43	14.72	0	2	2	0.00	11.11	11.11
Education Service	0	0	0	0.00	0.00	0.00	0.00	0.00	0.00	0	0	0	0.00	0.00	0.00
Other service	0	0	0	0.00	0.00	0.00	0.00	0.00	0.00	0	0	0	0.00	0.00	0.00
Total:	0	964583	964583	0	100	100	0.00	24.23	23.23	0	18	18	0.00	100.00	100.00
											18			100.00	

France

PRAIRIE PROVINCES:
(excluding indirect and incidental investment made)

Sector:	Asset Value: (000's)			% of Tot. Asset Value			% of Tot. CDN Asset Value:			Frequency:			% of Tot. Frequency:		
	New:	Acqu.:	Tot:	New:	Acqu.:	Tot:	New:	Acqu.:	Tot:	New:	Acqu.:	Tot:	New:	Acqu.:	Tot:
Manufacturing	0	5655	5655	0.00	0.74	0.74	0.00	0.61	0.60	0	6	6	0.00	40.00	40.00
Construction	0	0	0	0.00	0.00	0.00	0.00	0.00	0.00	0	0	0	0.00	0.00	0.00
Retail Trade	0	100	100	0.00	0.01	0.01	0.00	0.09	0.09	0	1	1	0.00	6.67	6.67
Agriculture	0	0	0	0.00	0.00	0.00	0.00	0.00	0.00	0	0	0	0.00	0.00	0.00
Logging & Forestry	0	0	0	0.00	0.00	0.00	0.00	0.00	0.00	0	0	0	0.00	0.00	0.00
Fishing & Trapping	0	0	0	0.00	0.00	0.00	0.00	0.00	0.00	0	0	0	0.00	0.00	0.00
Mining	0	2075	2075	0.00	0.27	0.27	0.00	2.40	2.39	0	1	1	0.00	6.67	6.67
Petro & Natural Gas	0	55674	55674	0.00	0.00	0.00	0.00	3.43	3.42	0	3	3	0.00	20.00	20.00
Wholesale Trade	0	660000	660000	0.00	86.36	86.36	0.00	40.64	40.52	0	1	1	0.00	6.67	6.67
Transport. & Storage	0	0	0	0.00	0.00	0.00	0.00	0.00	0.00	0	0	0	0.00	0.00	0.00
Real Estate & Ins. Agents	0	27685	27685	0.00	3.62	3.62	0.00	86.94	86.94	0	1	1	0.00	6.67	6.67
Finance & Insurance	0	0	0	0.00	0.00	0.00	0.00	0.00	0.00	0	0	0	0.00	0.00	0.00
Acc., Food & Beverages	0	0	0	0.00	0.00	0.00	0.00	0.00	0.00	0	0	0	0.00	0.00	0.00
Business Service	0	13026	13026	0.00	1.70	1.70	0.00	98.34	15.30	0	2	2	0.00	13.33	13.33
Education Service	0	0	0	0.00	0.00	0.00	0.00	0.00	0.00	0	0	0	0.00	0.00	0.00
Other service	0	0	0	0.00	0.00	0.00	0.00	0.00	0.00	0	0	0	0.00	0.00	0.00
Total:	0	764215	764215	0	92.71488	92.71488	0.00	25.00	23.67	0	15	15	0	100	100

France

ALBERTA:

Sector:	Asset Value: (000's)			% of Tot. Asset Value			% of Tot. CDN Asset Value:			Frequency:			% of Tot. Frequency:		
	New:	Acqu.:	Tot:	New:	Acqu.:	Tot:	New:	Acqu.:	Tot:	New:	Acqu.:	Tot:	New:	Acqu.:	Tot:
Manufacturing	0	5655	5655	0.00	0.72	0.72	0.00	0.35	0.35	0	6	6	0.00	40.00	40.00
Construction	0	0	0	0.00	0.00	0.00	0.00	0.00	0.00	0	0	0	0.00	0.00	0.00
Retail Trade	0	0	0	0.00	0.00	0.00	0.00	0.00	0.00	0	0	0	0.00	0.00	0.00
Agriculture	0	0	0	0.00	0.00	0.00	0.00	0.00	0.00	0	0	0	0.00	0.00	0.00
Logging & Forestry	0	0	0	0.00	0.00	0.00	0.00	0.00	0.00	0	0	0	0.00	0.00	0.00
Fishing & Trapping	0	0	0	0.00	0.00	0.00	0.00	0.00	0.00	0	0	0	0.00	0.00	0.00
Mining	0	9112	9112	0.00	1.17	1.17	0.00	3.33	3.33	0	2	2	0.00	13.33	13.33
Petro & Natural Gas	0	51974	51974	0.00	6.66	6.66	0.00	3.12	3.11	0	2	2	0.00	13.33	13.33
Wholesale Trade	0	673337	673337	0.00	86.24	86.24	0.00	40.46	40.34	0	2	2	0.00	13.33	13.33
Transport. & Storage	0	0	0	0.00	0.00	0.00	0.00	0.00	0.00	0	0	0	0.00	0.00	0.00
Real Estate & Ins. Agents	0	27685	27685	0.00	3.55	3.55	0.00	86.94	86.94	0	1	1	0.00	6.67	6.67
Finance & Insurance	0	0	0	0.00	0.00	0.00	0.00	0.00	0.00	0	0	0	0.00	0.00	0.00
Acc., Food & Beverages	0	0	0	0.00	0.00	0.00	0.00	0.00	0.00	0	0	0	0.00	0.00	0.00
Business Service	0	13026	13026	0.00	1.67	1.67	0.00	78.43	14.72	0	2	2	0.00	13.33	13.33
Education Service	0	0	0	0.00	0.00	0.00	0.00	0.00	0.00	0	0	0	0.00	0.00	0.00
Other service	0	0	0	0.00	0.00	0.00	0.00	0.00	0.00	0	0	0	0.00	0.00	0.00
Total:	0	780789	780789	0	100	100	0.00	19.61	18.81	0	15	15	0	100	100
											15			100	

France

ALBERTA:
(excluding indirect and incidental investment)

Sector:	Asset Value: (000's)			% of Tot. Asset Value			% of Tot. CDN Asset Value:			Frequency:			% of Tot. Frequency:		
	New:	Acqu.:	Tot:	New:	Acqu.:	Tot:	New:	Acqu.:	Tot:	New:	Acqu.:	Tot:	New:	Acqu.:	Tot:
Manufacturing	0	5655	5655	0.00	0.74	0.74	0.00	0.61	0.60	0	6	6	0.00	46.15	46.15
Construction	0	0	0	0.00	0.00	0.00	0.00	0.00	0.00	0	0	0	0.00	0.00	0.00
Retail Trade	0	0	0	0.00	0.00	0.00	0.00	0.00	0.00	0	0	0	0.00	0.00	0.00
Agriculture	0	0	0	0.00	0.00	0.00	0.00	0.00	0.00	0	0	0	0.00	0.00	0.00
Logging & Forestry	0	0	0	0.00	0.00	0.00	0.00	0.00	0.00	0	0	0	0.00	0.00	0.00
Fishing & Trapping	0	0	0	0.00	0.00	0.00	0.00	0.00	0.00	0	0	0	0.00	0.00	0.00
Mining -	0	2075	2075	0.00	0.27	0.27	0.00	2.40	2.39	0	1	1	0.00	7.69	7.69
Petro & Natural Gas	0	51974	51974	0.00	6.83	6.83	0.00	3.20	3.19	0	2	2	0.00	15.38	15.38
Wholesale Trade	0	660000	660000	0.00	86.79	86.79	0.00	40.64	40.52	0	1	1	0.00	7.69	7.69
Transport. & Storage	0	0	0	0.00	0.00	0.00	0.00	0.00	0.00	0	0	0	0.00	0.00	0.00
Real Estate & Ins. Agents	0	27685	27685	0.00	3.64	3.64	0.00	86.94	86.94	0	1	1	0.00	7.69	7.69
Finance & Insurance	0	0	0	0.00	0.00	0.00	0.00	0.00	0.00	0	0	0	0.00	0.00	0.00
Acc., Food & Beverages	0	0	0	0.00	0.00	0.00	0.00	0.00	0.00	0	0	0	0.00	0.00	0.00
Business Service	0	13026	13026	0.00	1.71	1.71	0.00	98.34	15.30	0	2	2	0.00	15.38	15.38
Education Service	0	0	0	0.00	0.00	0.00	0.00	0.00	0.00	0	0	0	0.00	0.00	0.00
Other service	0	0	0	0.00	0.00	0.00	0.00	0.00	0.00	0	0	0	0.00	0.00	0.00
Total:	0	760415	760415	0	100	100	0.00	24.87	23.55	0	13	13	0	100	100
											13			100	

France

SASKATCHEWAN:
(only indirect investment made)

Sector:	Asset Value: (000's)			% of Tot. Asset Value			% of Tot. CDN Asset Value:			Frequency:			% of Tot. Frequency:		
	New:	Acqu.:	Tot:	New:	Acqu.:	Tot:	New:	Acqu.:	Tot:	New:	Acqu.:	Tot:	New:	Acqu.:	Tot:
Manufacturing	0	0	0	0.00	0.00	0.00	0.00	0.00	0.00	0	0	0	0.00	0.00	0.00
Construction	0	0	0	0.00	0.00	0.00	0.00	0.00	0.00	0	0	0	0.00	0.00	0.00
Retail Trade	0	0	0	0.00	0.00	0.00	0.00	0.00	0.00	0	0	0	0.00	0.00	0.00
Agriculture	0	0	0	0.00	0.00	0.00	0.00	0.00	0.00	0	0	0	0.00	0.00	0.00
Logging & Forestry	0	0	0	0.00	0.00	0.00	0.00	0.00	0.00	0	0	0	0.00	0.00	0.00
Fishing & Trapping	0	0	0	0.00	0.00	0.00	0.00	0.00	0.00	0	0	0	0.00	0.00	0.00
Mining -	0	179994	179994	0.00	100.00	100.00	0.00	65.77	65.77	0	1	1	0.00	100.00	100.00
Petro & Natural Gas	0	0	0	0.00	0.00	0.00	0.00	0.00	0.00	0	0	0	0.00	0.00	0.00
Wholesale Trade	0	0	0	0.00	0.00	0.00	0.00	0.00	0.00	0	0	0	0.00	0.00	0.00
Transport. & Storage	0	0	0	0.00	0.00	0.00	0.00	0.00	0.00	0	0	0	0.00	0.00	0.00
Real Estate & Ins. Agents	0	0	0	0.00	0.00	0.00	0.00	0.00	0.00	0	0	0	0.00	0.00	0.00
Finance & Insurance	0	0	0	0.00	0.00	0.00	0.00	0.00	0.00	0	0	0	0.00	0.00	0.00
Acc., Food & Beverages	0	0	0	0.00	0.00	0.00	0.00	0.00	0.00	0	0	0	0.00	0.00	0.00
Business Service	0	0	0	0.00	0.00	0.00	0.00	0.00	0.00	0	0	0	0.00	0.00	0.00
Education Service	0	0	0	0.00	0.00	0.00	0.00	0.00	0.00	0	0	0	0.00	0.00	0.00
Other service	0	0	0	0.00	0.00	0.00	0.00	0.00	0.00	0	0	0	0.00	0.00	0.00
Total:	0	179994	179994	0	100	100	0.00	4.52	4.34	0	1	1	0	100	100

France

MANITOBA:

(only direct investment made)

Sector:	Asset Values: (000's)			% of Tot. Asset Value			% of Tot. CDN Asset Value:			Frequency:			% of Tot. Frequency:		
	New:	Acqu.:	Tot:	New:	Acqu.:	Tot:	New:	Acqu.:	Tot:	New:	Acqu.:	Tot:	New:	Acqu.:	Tot:
Manufacturing	0	0	0	0.00	0.00	0.00	0.00	0.00	0.00	0	0	0	0.00	0.00	0.00
Construction	0	0	0	0.00	0.00	0.00	0.00	0.00	0.00	0	0	0	0.00	0.00	0.00
Retail Trade	0	100	100	0.00	2.63	2.63	0.00	0.09	0.09	0	1	1	0.00	50.00	50.00
Agriculture	0	0	0	0.00	0.00	0.00	0.00	0.00	0.00	0	0	0	0.00	0.00	0.00
Logging & Forestry	0	0	0	0.00	0.00	0.00	0.00	0.00	0.00	0	0	0	0.00	0.00	0.00
Fishing & Trapping	0	0	0	0.00	0.00	0.00	0.00	0.00	0.00	0	0	0	0.00	0.00	0.00
Mining	0	0	0	0.00	0.00	0.00	0.00	0.00	0.00	0	0	0	0.00	0.00	0.00
Wholesale Trade	0	3700	3700	0.00	97.37	97.37	0.00	0.23	0.23	0	1	1	0.00	50.00	50.00
Transport. & Storage	0	0	0	0.00	0.00	0.00	0.00	0.00	0.00	0	0	0	0.00	0.00	0.00
Real Estate & Ins. Agents	0	0	0	0.00	0.00	0.00	0.00	0.00	0.00	0	0	0	0.00	0.00	0.00
Finance & Insurance	0	0	0	0.00	0.00	0.00	0.00	0.00	0.00	0	0	0	0.00	0.00	0.00
Acc., Food & Beverages	0	0	0	0.00	0.00	0.00	0.00	0.00	0.00	0	0	0	0.00	0.00	0.00
Business Service	0	0	0	0.00	0.00	0.00	0.00	0.00	0.00	0	0	0	0.00	0.00	0.00
Education Service	0	0	0	0.00	0.00	0.00	0.00	0.00	0.00	0	0	0	0.00	0.00	0.00
Other service	0	0	0	0.00	0.00	0.00	0.00	0.00	0.00	0	0	0	0.00	0.00	0.00
Total:	0	3800	3800	0	100	100	0.00	0.12	0.12	0	2	2	0	100	100

France

TORONTO:
(including indirect and incidental investment)

Sector:	Asset Value: (000's)			% of Tot. Asset Value			Frequency:			% of Tot. Frequency:		
	New:	Acqu.:	Tot:	New:	Acqu.:	Tot:	New:	Acqu.:	Tot:	New:	Acqu.:	Tot:
Manufacturing	300	12822	13122	5.61	7.78	7.72	1	2	3	4.55	9.09	13.64
Construction	300	0	300	5.61	0.00	0.18	1	0	1	4.55	0.00	4.55
Retail Trade	250	0	250	4.67	0.00	0.15	1	0	1	4.55	0.00	4.55
Agriculture	0	0	0	0.00	0.00	0.00	0	0	0	0.00	0.00	0.00
Logging & Forestry	0	0	0	0.00	0.00	0.00	0	0	0	0.00	0.00	0.00
Fishing & Trapping	0	0	0	0.00	0.00	0.00	0	0	0	0.00	0.00	0.00
Mining	0	0	0	0.00	0.00	0.00	0	0	0	0.00	0.00	0.00
Petro & Natural Gas	0	0	0	0.00	0.00	0.00	0	0	0	0.00	0.00	0.00
Wholesale Trade	1000	887	1887	18.69	0.54	1.11	6	1	7	27.27	4.55	31.82
Transport. & Storage	0	0	0	0.00	0.00	0.00	0	0	0	0.00	0.00	0.00
Real Estate & Ins. Agents	0	96015	96015	0.00	58.29	56.45	0	7	7	0.00	31.82	31.82
Finance & Insurance	3500	55009	58509	65.42	33.39	34.40	1	2	3	4.55	9.09	13.64
Acc., Food & Beverages	0	0	0	0.00	0.00	0.00	0	0	0	0.00	0.00	0.00
Business Service	0	0	0	0.00	0.00	0.00	0	0	0	0.00	0.00	0.00
Education Service	0	0	0	0.00	0.00	0.00	0	0	0	0.00	0.00	0.00
Health & Social Service	0	0	0	0.00	0.00	0.00	0	0	0	0.00	0.00	0.00
Other service	0	0	0	0.00	0.00	0.00	0	0	0	0.00	0.00	0.00
Total:	5350	164733	170083	100	100	100	10	12	22	45.45	54.55	100.00

100

France

TORONTO:
(excluding indirect and incidental investment)

Sector:	Asset Value:			% of Tot. Asset Value			Frequency:			% of Tot. Frequency:		
	New:	Acqu.:	Tot:	New:	Acqu.:	Tot:	New:	Acqu.:	Tot:	New:	Acqu.:	Tot:
Manufacturing	300	7892	8192	5.61	8.31	8.17	1	1	2	5.26	5.26	10.53
Construction	300	0	300	5.61	0.00	0.30	1	0	1	5.26	0.00	5.26
Retail Trade	250	0	250	4.67	0.00	0.25	1	0	1	5.26	0.00	5.26
Agriculture	0	0	0	0.00	0.00	0.00	0	0	0	0.00	0.00	0.00
Logging & Forestry	0	0	0	0.00	0.00	0.00	0	0	0	0.00	0.00	0.00
Fishing & Trapping	0	0	0	0.00	0.00	0.00	0	0	0	0.00	0.00	0.00
Mining	0	0	0	0.00	0.00	0.00	0	0	0	0.00	0.00	0.00
Petro & Natural Gas	0	0	0	0.00	0.00	0.00	0	0	0	0.00	0.00	0.00
Wholesale Trade	1000	887	1887	18.69	0.93	1.88	6	1	7	31.58	5.26	36.84
Transport. & Storage	0	0	0	0.00	0.00	0.00	0	0	0	0.00	0.00	0.00
Real Estate & Ins. Agents	0	84936	84936	0.00	89.47	84.70	0	6	6	0.00	31.58	31.58
Finance & Insurance	3500	1219	4719	65.42	1.28	4.71	1	1	2	5.26	5.26	10.53
Acc., Food & Beverages	0	0	0	0.00	0.00	0.00	0	0	0	0.00	0.00	0.00
Business Service	0	0	0	0.00	0.00	0.00	0	0	0	0.00	0.00	0.00
Education Service	0	0	0	0.00	0.00	0.00	0	0	0	0.00	0.00	0.00
Health & Social Service	0	0	0	0.00	0.00	0.00	0	0	0	0.00	0.00	0.00
Other service	0	0	0	0.00	0.00	0.00	0	0	0	0.00	0.00	0.00
Total:	5350	94934	100284	100	100	100	10	9	19	52.63	47.37	100.00

France

MONTREAL:
(including indirect and incidental investment)

Sector:	Asset Value: (000's)			% of Tot. Asset Value			Frequency:			% of Frequency:		
	New:	Acqu.:	Tot:	New:	Acqu.:	Tot:	New:	Acqu.:	Tot:	New:	Acqu.:	Tot:
Manufacturing	0	324644	324644	0.00	97.47	97.47	0	2	2	0.00	33.33	33.33
Construction	0	0	0	0.00	0.00	0.00	0	0	0	0.00	0.00	0.00
Retail Trade	0	0	0	0.00	0.00	0.00	0	0	0	0.00	0.00	0.00
Agriculture	0	0	0	0.00	0.00	0.00	0	0	0	0.00	0.00	0.00
Logging & Forestry	0	0	0	0.00	0.00	0.00	0	0	0	0.00	0.00	0.00
Fishing & Trapping	0	0	0	0.00	0.00	0.00	0	0	0	0.00	0.00	0.00
Mining	0	0	0	0.00	0.00	0.00	0	0	0	0.00	0.00	0.00
Petro & Natural Gas	0	0	0	0.00	0.00	0.00	0	0	0	0.00	0.00	0.00
Wholesale Trade	20	8411	8431	100.00	2.53	2.53	1	3	4	16.67	50.00	66.67
Transport. & Storage	0	0	0	0.00	0.00	0.00	0	0	0	0.00	0.00	0.00
Real Estate & Ins. Agents	0	0	0	0.00	0.00	0.00	0	0	0	0.00	0.00	0.00
Finance & Insurance	0	0	0	0.00	0.00	0.00	0	0	0	0.00	0.00	0.00
Acc., Food & Beverages	0	0	0	0.00	0.00	0.00	0	0	0	0.00	0.00	0.00
Business Service	0	0	0	0.00	0.00	0.00	0	0	0	0.00	0.00	0.00
Education Service	0	0	0	0.00	0.00	0.00	0	0	0	0.00	0.00	0.00
Other service	0	0	0	0.00	0.00	0.00	0	0	0	0.00	0.00	0.00
Total:	20	333055	333075	100	100	100	1	5	6	16.66667	83.33333	100.00
								6				100

France

MONTREAL:
(excluding indirect and incidental investment)

Sector:	Asset Value: (000's)			% of Tot. Asset Value			Frequency:			% of Tot. Frequency:		
	New:	Acqu.:	Tot:	New:	Tot:		New:	Acqu.:	Tot:	New:	Acqu.:	Tot:
Manufacturing	0	11644	11644	0.00	58.06	58.00	0	1	1	0.00	20.00	20.00
Construction	0	0	0	0.00	0.00	0.00	0	0	0	0.00	0.00	0.00
Retail Trade	0	0	0	0.00	0.00	0.00	0	0	0	0.00	0.00	0.00
Agriculture	0	0	0	0.00	0.00	0.00	0	0	0	0.00	0.00	0.00
Logging & Forestry	0	0	0	0.00	0.00	0.00	0	0	0	0.00	0.00	0.00
Fishing & Trapping	0	0	0	0.00	0.00	0.00	0	0	0	0.00	0.00	0.00
Mining	0	0	0	0.00	0.00	0.00	0	0	0	0.00	0.00	0.00
Petro & Natural Gas	0	0	0	0.00	0.00	0.00	0	0	0	0.00	0.00	0.00
Wholesale Trade	20	8411	8431	100.00	41.94	42.00	1	3	4	20.00	60.00	80.00
Transport. & Storage	0	0	0	0.00	0.00	0.00	0	0	0	0.00	0.00	0.00
Real Estate & Ins. Agents	0	0	0	0.00	0.00	0.00	0	0	0	0.00	0.00	0.00
Finance & Insurance	0	0	0	0.00	0.00	0.00	0	0	0	0.00	0.00	0.00
Acc., Food & Beverages	0	0	0	0.00	0.00	0.00	0	0	0	0.00	0.00	0.00
Business Service	0	0	0	0.00	0.00	0.00	0	0	0	0.00	0.00	0.00
Education Service	0	0	0	0.00	0.00	0.00	0	0	0	0.00	0.00	0.00
Other service	0	0	0	0.00	0.00	0.00	0	0	0	0.00	0.00	0.00
Total:	20	20055	20075	100	100	100	1	4	5	20.00	80.00	100.00

France

VANCOUVER:
(no indirect or incidental investment made)

Sector:	Asset Value: (000's)			% of Tot. Asset Value			Frequency:			% of Tot. Frequency:		
	New:	Acqu.:	Tot:	New:	Acqu.:	Tot:	New:	Acqu.:	Tot:	New:	Acqu.:	Tot:
Manufacturing	0	0	0	0.00	0.00	0.00	0	1	1	0.00	20.00	20.00
Construction	0	0	0	0.00	0.00	0.00	0	0	0	0.00	0.00	0.00
Retail Trade	0	0	0	0.00	0.00	0.00	0	0	0	0.00	0.00	0.00
Agriculture	0	0	0	0.00	0.00	0.00	0	0	0	0.00	0.00	0.00
Logging & Forestry	0	0	0	0.00	0.00	0.00	0	0	0	0.00	0.00	0.00
Fishing & Trapping	0	0	0	0.00	0.00	0.00	0	0	0	0.00	0.00	0.00
Mining	0	0	0	0.00	0.00	0.00	0	0	0	0.00	0.00	0.00
Petro. & Natural Gas	0	0	0	0.00	0.00	0.00	0	0	0	0.00	0.00	0.00
Wholesale Trade	30	2275	2305	100.00	3.97	4.02	1	0	1	20.00	0.00	20.00
Transport. & Storage	0	0	0	0.00	0.00	0.00	0	0	0	0.00	0.00	0.00
Real Estate & Ins. Agents	0	55000	55000	0.00	96.03	95.98	0	1	1	0.00	20.00	20.00
Finance & Insurance	0	0	0	0.00	0.00	0.00	0	0	0	0.00	0.00	0.00
Acc., Food & Beverages	0	0	0	0.00	0.00	0.00	2	0	2	40.00	0.00	40.00
Business Service	0	0	0	0.00	0.00	0.00	0	0	0	0.00	0.00	0.00
Education Service	0	0	0	0.00	0.00	0.00	0	0	0	0.00	0.00	0.00
Other service	0	0	0	0.00	0.00	0.00	0	0	0	0.00	0.00	0.00
Total:	30	57275	57305	100	100	100	3	2	5	60.00	40.00	100.00

France

CALGARY:
(only direct investment was made)

Sector:	Asset Value: (000's)			% of Tot. Asset Value			Frequency:			% of Tot. Frequency:		
	New:	Acqu.:	Tot:	New:	Acqu.:	Tot:	New:	Acqu.:	Tot:	New:	Acqu.:	Tot:
Manufacturing	0	2400	2400	0.00	6.48	5.07	0	1	1	0.00	10.00	10.00
Construction	5767	0	5767	55.84	0.00	12.17	1	0	1	10.00	0.00	10.00
Retail Trade	0	11632	11632	0.00	31.40	24.56	0	1	1	0.00	10.00	10.00
Agriculture	0	0	0	0.00	0.00	0.00	0	0	0	0.00	0.00	0.00
Logging & Forestry	0	0	0	0.00	0.00	0.00	0	0	0	0.00	0.00	0.00
Fishing & Trapping	0	0	0	0.00	0.00	0.00	0	0	0	0.00	0.00	0.00
Mining	0	0	0	0.00	0.00	0.00	0	0	0	0.00	0.00	0.00
Petro & Natural Gas	0	0	0	0.00	0.00	0.00	0	0	0	0.00	0.00	0.00
Wholesale Trade	0	4999	4999	0.00	13.50	10.55	0	1	1	0.00	10.00	10.00
Transport. & Storage	10	0	10	0.10	0.00	0.02	1	0	1	10.00	0.00	10.00
Real Estate & Ins. Agents	4300	18000	22300	41.64	48.59	47.08	2	1	3	20.00	10.00	30.00
Finance & Insurance	0	0	0	0.00	0.00	0.00	0	0	0	0.00	0.00	0.00
Acc., Food & Beverages	0	0	0	0.00	0.00	0.00	0	0	0	0.00	0.00	0.00
Business Service	0	10	10	0.00	0.03	0.02	0	1	1	0.00	10.00	10.00
Education Service	0	0	0	0.00	0.00	0.00	0	0	0	0.00	0.00	0.00
Other service	250	0	250	2.42	0.00	0.53	1	0	1	10.00	0.00	10.00
Total:	10327	37041	47368	100.00	100.00	100	5	5	10	50.00	50.00	100.00

France

CALGARY:
(excluding indirect and incidental investment)

Sector:	Asset Value: (000's)			% of Tot. Asset Value			Frequency:			% of Tot. Frequency:		
	New:	Acqu.:	Tot:	New:	Acqu.:	Tot:	New:	Acqu.:	Tot:	New:	Acqu.:	Tot:
Manufacturing	0	0	0	0.00	0.00	0.00	0	0	0	0.00	0.00	0.00
Construction	0	0	0	0.00	0.00	0.00	0	0	0	0.00	0.00	0.00
Retail Trade	0	0	0	0.00	0.00	0.00	0	0	0	0.00	0.00	0.00
Agriculture	0	0	0	0.00	0.00	0.00	0	0	0	0.00	0.00	0.00
Logging & Forestry	0	0	0	0.00	0.00	0.00	0	0	0	0.00	0.00	0.00
Fishing & Trapping	0	0	0	0.00	0.00	0.00	0	0	0	0.00	0.00	0.00
Mining	0	0	0	0.00	0.00	0.00	0	0	0	0.00	0.00	0.00
Petro & Natural Gas	0	0	0	0.00	0.00	0.00	0	0	0	0.00	0.00	0.00
Wholesale Trade	0	660000	660000	0.00	98.06	98.06	0	1	1	0.00	33.33	33.33
Transport. & Storage	0	0	0	0.00	0.00	0.00	0	0	0	0.00	0.00	0.00
Real Estate & Ins. Agents	0	0	0	0.00	0.00	0.00	0	0	0	0.00	0.00	0.00
Finance & Insurance	0	0	0	0.00	0.00	0.00	0	0	0	0.00	0.00	0.00
Acc., Food & Beverages	0	0	0	0.00	0.00	0.00	0	0	0	0.00	0.00	0.00
Business Service	0	13026	13026	0.00	1.94	1.94	0	2	2	0.00	66.67	66.67
Education Service	0	0	0	0.00	0.00	0.00	0	0	0	0.00	0.00	0.00
Other service	0	0	0	0.00	0.00	0.00	0	0	0	0.00	0.00	0.00
Total:	0	673026	673026	0	100	100	0	3	3	0.00	100.00	100.00