

QUEEN
TK
301
.C36
1986

IC

Canada. Legal Metrology Branch.
Specifications for approval of type of
electricity meters, instrument transformers
and auxiliary devices.

TK301
.C36
1986
CCA
FILE

Canada

SPECIFICATIONS FOR APPROVAL OF
TYPE OF ELECTRICITY METERS,
INSTRUMENT TRANSFORMERS AND
AUXILIARY DEVICES

DEPARTMENT OF CONSUMER &
CORPORATE AFFAIRS
LIBRARY
AUG 24 1993
BIBLIOTHÈQUE
MINISTÈRE DE LA CONSOMMATION
ET DES CORPORATIONS



Consommation
et Corporations Canada

Consumer and
Corporate Affairs Canada

Direction de la
Métrologie légale

Legal Metrology
Branch

Whereas subsection 12(1) of the Electricity and Gas Inspection Regulations provides that the director appointed under subsection 26(1) of the Electricity and Gas Inspection Act shall establish specifications relating to design, composition, construction and performance to which any meter or any class, type or design of meter shall conform before permission or approval with regard to that meter or such class, type or design of meter may be given pursuant to section 9 of the said Act.

Therefore, the Director of the Legal Metrology Branch of the Department of Consumer and Corporate Affairs is pleased hereby to establish the annexed specifications for the approval of the types of electricity meters, instrument transformers and auxiliary devices referred to therein.



Richard G. Knapp
Director, Legal Metrology Branch
Department of Consumer and Corporate Affairs

SEP 15 1986

SPECIFICATIONS FOR APPROVAL OF TYPE
OF
ELECTRICITY METERS
INSTRUMENT TRANSFORMERS
AND
AUXILIARY DEVICES

CONTENTS

SECTION	PAGE
1. SCOPE.	1
2. DEFINITIONS.	2
3. GENERAL.	11
4. INDUCTION TYPE WATT HOUR METERS.	23
5. INDUCTION TYPE VAR HOUR AND Q-HOUR METERS	38
6. STATIC INTEGRATING METERS.	47
7. DEMAND METERS.	54
8. INDUCTION TYPE LOSS METERS	65
9. STATIC LOSS METERS	70
10. TRANSDUCERS.	74
11. NULL BALANCING INSTRUMENTS	81
12. PULSE DEVICES.	92
13. PROGRAMMABLE DEVICES AND PULSE RECORDERS	96
14. INSTRUMENT TRANSFORMERS.	100
15. STATIC DEMAND METERS	115
16. INDUCTION TYPE VOLTAGE-SQUARED HOUR METERS	120
17. STATIC VOLTAGE-SQUARED HOUR METERS	124
18. SUB-METERING	128
19. SIGNAL CONVERTERS.	131

SECTION 1 - SCOPE

This specification establishes acceptable performance criteria for new types of electricity meters, instrument transformers and auxiliary devices intended for use in revenue metering. The criteria apply also to modifications which may be made, in future, to existing approved devices.

This document refers to the following and where such reference is made it shall be considered to refer to the latest edition and any revisions thereto:

Canadian Standards Association Standard C17; Electricity Meters.

Canadian Standards Association Standard C13; Instrument Transformers.

National Standard of Canada CAN-Z234.1; Canadian Metric Practice Guide.

American National Standards Institute Standard C37-90a/Institute of Electrical and Electronic Engineers Standard 472; IEEE Guide for Surge Withstand Capability (SWC) Tests.

United States Department of Defense Military Standard MIL-STD-461B; Electromagnetic Emission and Susceptibility Requirements for the Control of Electromagnetic Interference.

National Standard of Canada CAN3-Z234.4; All-Numeric Dates and Times.

SECTION 2 - DEFINITION

Definitions relating to meters and auxiliary devices are included in this section. Definitions pertaining to instrument transformers are listed in subsection 14-2.

2-1 Accuracy Rating of a Null Balancing Instrument. The limit which errors will not exceed when the instrument is used under any combination of rated operating conditions, expressed as a percent of the span.

2-2 Ambient Temperature. The temperature of the medium, such as gas or liquid, in which the device or apparatus under examination is immersed.

2-3 Approval Test. The testing of one or more meters or other items under various controlled conditions to ascertain the performance characteristics of the type of which they are representative.

2-4 Auxiliary Timing Device. A timing device which controls certain functions of other meters or devices but which is separately housed.

2-5 Basic Current. The value of current in accordance with which the relevant performance of the meter is fixed. For an induction-type watt hour meter this is equal to the high load test current.

2-6 Block Interval Demand Meter. See Integrating Demand Meter.

2-7 Case (of the Meter). The complete outside enclosure.

2-8 Chart. Graduated material upon which a pen or stylus draws a record, or upon which is printed a record, of the quantity or quantities being measured by an instrument.

2-9 Common Mode Interference. A form of interference which appears between any measuring circuit terminal and ground.

Continuous Cumulative Demand Register. A register that displays the continuous sum of all the peak demands of each demand interval subsequent to the register being reset.

2-10 Cover (of the Meter). That part of the case which is removable, for access to working parts and adjustments.

2-11 Creep. A meter is said to creep if the rotor makes a complete revolution when the voltage coils are energized with rated voltage and with no current in any current coil.

2-12 Cumulative Demand Register. A register that indicates the sum of the previous maximum demand readings prior to reset. When reset, the present reading is added to the previous accumulated readings. The maximum demand for the present reading period is the difference between the present and previous readings.

2-13 Current Range. The range of currents over which the meter purports to meet the requirements of these specifications. The upper and lower limits are maximum rated current and minimum rated current.

2-14 Damping Characteristic (of a null balancing instrument). The maximum overshoot (if any) beyond the point of final rest, expressed in percent of span.

2-15 Dead Band (of a null balancing instrument). The range through which the measured quantity can be varied without initiating response, expressed in percent of span.

2-16 Demand. The rate at which the particular quantity, i.e. active energy, reactive energy, etc., is being supplied to the load. Generally, it is indicated, recorded or computed as the average obtained over a specified time interval.

2-17 Demand Interval (of an integrating demand meter or of a pulse recorder). The specified interval of time on which a demand measurement is based.

2-18 Demand Interval Deviation. The difference between the measured demand interval and the specified demand interval, expressed as a percentage of the specified demand interval.

2-19 Demand Meter. A meter that indicates or records either the demand, maximum demand, or both.

Note: A demand meter may be either an integrating or lagged demand meter.

2-20 Dielectric Tests. Tests consisting of the application of a voltage higher than the rated voltage for a specified time for the purpose of determining the adequacy against breakdown of insulating materials and spacing under normal conditions.

2-21 Director. The Director of the Legal Metrology Branch, Department of Consumer and Corporate Affairs.

2-22 Disc Constant K_h . The registration, expressed in units of the quantity being measured per revolution of the disc.

2-23 Display. A means for visually identifying and presenting electronically measured or calculated quantities and other information.

2-24 Electromagnetic Interference (EMI). Any electromagnetic energy which interrupts, obstructs or otherwise degrades or limits the effective performance of metering.

2-25 Error.

(a) **Absolute Error.** The value registered by the meter minus the true value.

(b) **Relative Error.** The ratio of the absolute error to the true value.

(c) **Percentage Error.** The relative error multiplied by 100.

The percentage error is given by the following:

$$\text{Percentage Error} = \frac{\text{Meter Registration} - \text{True Value}}{\text{True Value}} \times 100$$

(d) **Error of a Transducer.** The observed value of the output minus the ideal value, where the ideal value is calculated from the value of the measured input quantity and the transfer constant K_a .

2-26 External Circuit Resistance. The resistance of that part of the measuring circuit which is external to the instrument.

2-27 Frame (of a Meter). That part to which are affixed the working parts and adjustments.

2-28 Full Scale Value. The largest value of the actuating electrical quantity that can be indicated on the scale or, in the case of an instrument having its zero between the end of the scale, the full-scale value is the arithmetic sum of the values of the actuating electrical quantity corresponding to the two ends of the scale.

2-29 Indicating Demand Meter. A demand meter equipped with a readout that indicates demand, maximum demand or both.

2-30 Integral Timing Device. One which is mounted within the case of the billing instrument.

2-31 Integrating Demand Meter (Block-Interval Demand Meter). A demand meter in which the demand is derived through integration of the measured quantity, with respect to time.

2-32 Interference. Any spurious voltage or current appearing in the circuits of the instrument which interferes with proper operation of the instrument.

2-33 Lagged Demand Meter. A demand meter in which the indication of the demand is subject to a characteristic time lag produced by either thermal or mechanical means.

2-34 Minimum Current. The smallest load current for which a device must operate within specified error limits. Unless otherwise specified, the minimum current shall be taken to be 1% of I_{max} .

2-35 Maximum Demand. The greatest of all demands which have occurred during a specific period of time, usually the billing period i.e. a month, two months, etc.

2-36 Maximum Demand Indicator (Demand Attachment). A mechanism intended for mounting in an electricity meter, which indicates or registers maximum demand.

Note: The mechanism may also register energy.

2-37 Meter Multiplier. The factor by which the register reading must be multiplied to obtain the registration in the stated units.

2-38 Multi-Rate Meter. A meter provided with a register having more than one readout, each readout becoming operative at times corresponding to different rates of charge.

2-39 Nominal Power Factor (or Reactive Factor) (of a transducer). The ratio of rated input power to the product of the rated voltage and maximum rated input current for single phase transducers. For polyphase transducers the product is multiplied by either $\sqrt{3}$ (when the nominal voltage is phase-phase) or by 3 (when the nominal voltage is phase-neutral).

NOTE: (1) Power may be active or reactive according to the kind of transducer.

(2) Where no maximum rating is stated the value of rated current is substituted.

2-40 Nominal Value (of a transducer). A value, or one of the values indicating the rating and intended use of a transducer.

2-41 Normal Mode Interference. A form of interference which appears between measuring circuit terminals.

2-42 Percentage Registration. The ratio of the actual registration of the meter to the true value of the quantity being measured, expressed as a percentage.

2-43 Power Factor. The ratio of the active power to the apparent power. Power factor is given by $\cos\phi$, where ϕ is the phase angle of the load.

2-44 Prescalar Unit. The ratio of the number of input pulses per output pulse.

2-45 Pulse Count Deviation (of a pulse recorder). The difference between the number of recorded pulses and the number of pulses supplied to the input terminals of a pulse recorder (true count), expressed as a percentage of the true count. Pulse-count deviation is applicable to each data channel of a pulse recorder.

2-46 Pulse Initiator. Any device used with a meter to initiate pulses, the number of which is proportional to the quantity being measured.

2-47 Pulse Initiator Output Constant (K_p). The value of the measured quantity for each outgoing pulse of a pulse initiator expressed in kilowatt hours per pulse, kilovar hours per pulse or other suitable units.

2-48 Q-Hour Meter. An electricity meter that measures a quantity that may be obtained by effectively lagging the applied voltage to a watthour meter by 60° . This quantity is one of the quantities used in calculating quädergy (var hours).

2-49 Range, of an indicating or recording meter. The region covered by the span and expressed by stating the two end-scale values.

NOTE: If the span passes through zero, the range is stated by inserting "zero" or "0" between the end-scale values.

2-50 Rated Frequency. The frequency or frequencies for which the meter is designed.

2-51 Rated Input Power (of a transducer). The nominal value of the measured quantity. Rated input power may be active, reactive or apparent.

2-52 Rated Output (of a transducer). The nominal value of the output quantity corresponding to the rated input power. The rated output is the span except for transducers having a symmetrical reversible input and output. In this case, the rated output shall be half the span.

2-53 Rated Output Load Resistance (of a current-output type of transducer). The maximum value intended for connection across the output terminals.

2-54 Rated Voltage. The voltage or voltages for which the meter or device is designed.

2-55 Reactive Factor. The ratio of the reactive power to the apparent power. Reactive factor is given by $\sin\phi$, where ϕ is the phase angle of the load.

2-56 Recording Demand Meter. A demand meter in which the indications of demand are recorded on a moving chart, paper or magnetic tape, or in solid state memory.

2-57 Reference Low-Load Speed. The rotor speed of an induction watt hour meter operating under reference conditions (clause 4-5.1) and at 2.5% of maximum rated current, unity power factor.

2-58 Reference Temperature. The ambient temperature at which type testing is carried out and to which type tests at other temperatures may be referred.

2-59 Register. A device which registers the value of the quantity measured by the meter.

2-60 Register Ratio R_r (of an induction type integrating meter). The number of revolutions of the first gear of the register for one revolution of the first dial pointer.

2-61 Reset Time (of a demand register). The interval of time within each demand interval during which the coupling between driving element and demand indicator is disconnected to allow the driving element to be restored to its initial position.

2-62 Resetting Device. Device which enables the maximum demand to be reset manually or by other means.

2-63 Response Period (of a lagged demand meter). The time required for the meter indication to reach 90 percent of the final response to a step change in the measured quantity.

2-64 Sealing Device. Means whereby unauthorized access to the interior and adjustments of a meter may be effectively impeded.

2-65 Self-Contained Meter. A meter designed to be connected directly to a power circuit, without the use of external devices such as instrument transformers or shunts.

2-66 Single-Phase Test Constant K_{tc} (of a polyphase var hour meter). The ratio of the single-phase watt hour disc constant K_{wh} of a class 90° meter to the var hour disc constant.

2-67 Single-Phase Watt Hour Disc Constant K_{wh} (of a polyphase var hour meter). The watt hour disc constant when a class 90° meter is operated single phase with all voltage circuits connected in parallel and all current circuits connected in series assisting.

2-68 Span. The algebraic difference between the end-scale values. For a transducer, the output span is the algebraic difference between the upper and lower values of the output range.

2-69 Strip Chart (roll type chart). A chart in the form of a roll or reel upon which the measured quantities are recorded.

2-70 Surge Withstand Capability (SWC). The capability of a device to withstand surges as demonstrated by a specified design test.

2-71 Test Constant K_s (of a static watthour meter). The registration expressed in units of the quantity being measured per indication of the test device.

2-72 Test Device (of a static watthour meter). A device provided on static meters to facilitate high-speed manual and automatic testing.

2-73 Test Link. A device provided to isolate the voltage circuit from the current circuit, for the purpose of testing.

2-74 Timing Device. A clock, timing motor, or device, used to determine the demand interval, drive a chart, or actuate any mechanism of the billing instrument on a time basis.

2-75 Transducer. A device for converting an alternating electrical quantity into another quantity for measurement purposes.

2-76 Transfer Constant K_a (of a transducer). The ratio of the rated input to the rated output.

2-77 Transformer-Rated Meter. A meter designed for use with specific instrument transformer ratios. It thus indicates or records the primary quantity being measured.

2-78 Transformer-Type Meter. A meter designed to be used with instrument transformers.

2-79 Transient Overshoot. An excursion beyond the final steady-state value of output as the result of an input change.

2-80 True Value. The value established by a regulatory authority as being correct within certain limits of uncertainty.

2-81 Type. The designation assigned to a meter or device by the manufacturer for the purpose of distinguishing its particular design and construction from other designs, models or patterns. Such type designation shall embrace only those ranges and ratings that are essentially similar in appearance and performance.

2-82 Update Interval. The interval of time separating the periodic calculations of demand. The demand interval normally comprises several update intervals.

2-83 Volatile (Memory). Pertaining to a storage device in which data cannot be retained without continuous power dissipation.

2-84 Var Hour Meter (Reactive Energy Meter). An integrating instrument which measures reactive energy in var hours or in suitable multiples thereof.

2-85 Watt Hour Meter. An integrating instrument which measures active energy in watt hours or in suitable multiples thereof.

SECTION 3 - GENERAL

CONTENTS

	Page
3-1	SCOPE 12
3-2	MECHANICAL REQUIREMENTS 12
3-2.1	Design and Construction 12
3-2.2	Case 12
3-2.3	Inspection of Working Parts 12
3-2.4	Finish 12
3-2.5	Terminals 13
3-2.6	Sealing 14
3-2.7	Registers 14
3-2.8	Displays 16
3-3	ELECTRICAL REQUIREMENTS 16
3-3.1	Adjustability 16
3-3.2	Voltage Ratings 17
3-3.3	Temperature Rise 17
3-3.4	Dielectric Tests 17
3-3.5	Carry-Over Time Base 19
3-3.6	Communications Security 19
3-3.7	Battery Condition Indicator 19
3-4	MARKINGS 19
3-4.1	Nameplates 19
3-4.2	Nameplate Location 19
3-5	PERFORMANCE REQUIREMENTS 20
3-5.1	Reference Conditions for Tests 20
3-5.2	EMI Susceptibility 20
3-5.3	Effects of Ambient Temperature 22
3-5.4	Reverse Operation 22

SECTION 3 - GENERAL

3-1 SCOPE

These requirements apply to all appropriate types of meter or device which may be submitted for approval of type.

3-2 MECHANICAL REQUIREMENTS

3-2.1 Design & Construction. The design shall be suitable for the intended purpose and expected service conditions.

The construction shall be mechanically and electrically sound, and the materials, finish, etc., shall be such as to provide assurance of long life and sustained accuracy.

The meter or device shall be sufficiently shock-proof to withstand the handling encountered under normal conditions of transportation by common carrier.

3-2.2 Case. The meter or device shall have a substantially dust-proof case, not liable to distortion or damage due to normal changes of temperature, presence of moisture, or other normal conditions.

3-2.3 Inspection of Working Parts. Where applicable, provision shall be made for a clear view, with cover in place, of the register, the test dial and of those other working parts, the observation of which is necessary for efficient testing and reading of the meter.

3-2.4 Finish. The finish on the register face and nameplate shall be of durable material which will not fade, chip, flake, or discolour.

3-2.5 Terminals

3-2.5.1 Markings. In order to facilitate the proper connections, the terminals on the meter shall have clearly identifiable markings, as follows:

(a) For a self-contained single-phase meter without accessories, sufficient identification will be the word "line" on the terminal cover of bottom-connected meters or on the base of a socket-type meter.

(b) For all other, a complete diagram of internal connections, satisfactorily located and secured, is required. If it is significant for proper operations, the phase sequence shall be shown.

3-2.5.2 Sealing of Terminals. Except in the case of S-base meters and back-connected switchboard meters, provision shall be made so that the terminals may be effectively sealed against tampering.

3-2.5.3 Dimensions.

3-2.5.3.1 The current terminals shall be large enough to accommodate the proper cable size as given in Table 1.

TABLE I
MINIMUM SIZE CURRENT TERMINALS

Maximum Current Rating of Meter Amps	Terminals Must Accommodate Lead Size (Cu, AWG)
Up to 10	12
Over 10, up to 20	8
Over 20, up to 30	6
Over 30, up to 60	4
Over 60, up to 100	2
Over 100, up to 200	1/0

3-2.5.3.2 The terminals of transformer-type meters shall be capable of making a sound electrical connection with one strand of No. 12 solid wire.

3-2.5.3.3 It shall not be possible for the terminal cover to come in contact with the terminal screws when they are tightened on the largest size cable which can be accommodated.

3-2.6 Sealing. The meter or device shall be so constructed that access to the working parts and adjustments may be effectively prevented by such sealing arrangements as may be approved by the director.

3-2.6.1 Replacement of Batteries. Devices fitted with carry-over batteries which must be periodically replaced within the sealing period of the device, shall be sealed in such a manner to allow replacement of the battery without having to break the seal.

3-2.7 Registers.

3-2.7.1 Minimum number of dials or drums for measured quantities shall be four.

3-2.7.2 Units. The units in which the record is made, e.g. kilowatthours, shall be marked in large letters on the register face. SI symbols as set forth in CAN3-Z234.1 are acceptable.

3-2.7.3 Markings. Except for the manufacturer's name, trade mark, the direction of rotation indicator, register ratio, rotation index mark, multiplier, or marks pertaining to the reading of the register, no markings of any kind shall be made on the register face. Where the register face and nameplate are integral, the above requirement shall not apply but any markings shall not be such as to interfere with reading of the register.

It is not permissible to indicate above or below any individual dial or drum the magnitude of either the complete indication or of the divisions.

The zero of clock-type dials shall be at the 12 o'clock position.

3-2.7.4 Multiplier. The meter multiplier, if other than unity, shall be marked permanently and prominently, preferably in red, on the register face.

3-2.7.5 Clock Registers. The minimum diameter of clock dial circles shall be 10 mm.

Each dial shall be divided into ten equal and clearly numbered divisions. Preferably, the dials shall be distinctly separated from each other. The lowest reading dial shall be on the right, and shall rotate in a clockwise direction viewed from the front. The gearing shall be such that a complete revolution of any pointer shall cause the adjacent pointer on the left to advance one division.

Preferably the dial centres should lie in a straight line or on the arc of a circle, but in any case shall be so located as to avoid any possibility of ambiguity in reading.

3-2.7.6 Cyclometer Registers. The test dial, in the case of a cyclometer-type register, may be of either the drum or pointer type.

If the test dial is of the drum type, it shall be divided into ten equal numbered divisions, shall be marked "test dial", and a reference mark shall be provided on the register face for accurate reading.

The arrangement of the cyclometer drums and the cutouts on the register face, shall be such that, with the exception of the fastest moving drum, one and only one digit is in full view at all times except when the drum is advancing from one position to another. The duration of this change period shall not exceed the time required for the fastest-moving drum to make one-tenth of a revolution.

All windows in the register face shall lie in a straight line and be of the same size.

The size and shape of any numerals shall be such that they are clearly legible.

3-2.7.7 Multi-rate registers. For mechanical multi-rate registers the on-peak register shall be the uppermost, shall have red pointers or drums and shall be the register in operation when the change-over device is energized.

Means shall be provided to indicate which register is in operation.

The register changeover device shall operate reliably at 80% of rated voltage.

3-2.7.7.1 Registers Changed By Temperature. The temperature sensor of a register which switches from one rate to another on the basis of temperature shall be designed so that in service, the sensor is protected from radiant energy in order to respond only to ambient temperature.

3-2.7.7.1.1 Switching Range. Such registers shall make the change within $\pm 1.0^{\circ}\text{C}$ of the specified change-over temperature.

3-2.7.7.1.2 Response Time. The sensors of temperature switched registers shall be subjected to a sudden temperature change from 2°C below to 2°C above the specified change-over temperature. The sudden temperature change means the change shall be completed within a period of one minute. The switching of the register shall occur within ten minutes of the temperature change.

Testing shall be repeated by changing the temperature from 2°C above to 2°C below the specified change-over temperature.

3-2.7.7.2 Failure Mode Of Multi-Rate Registers. Mechanical multi-rate registers shall be so designed that in the event of an electrical failure of the change-over device, the lowest rate, or off-peak register shall be engaged.

3-2.7.8 Register Resets. Registers displaying integrated quantities, eg. kW.h, kQ.h, etc., shall not be resettable, i.e. reset to zero, unless the accumulated total readings are stored in another memory or register location for recall at any time.

3-2.8 Displays. Any digital electronic display shall be readily readable under normal conditions of use. The minimum height of the metered quantity displayed shall be 5 mm. A minimum of five digits shall be provided to display a measured energy quantity. A minimum of three digits shall be provided to display demand. Cumulative demand shall be displayed by at least four digits.

If one digital display is used to display several different quantities, an indication code shall be provided to identify each quantity displayed.

The minimum display time for measured quantities to be manually recorded shall be 6 seconds.

A device fitted with an electronic register or other display means the information of which could be lost in the event of a power outage, shall be fitted with a battery carry-over feature to prevent the loss of the display information over the following minimum intervals:

- (a) For 24 hours for a device which automatically recharges the standby battery upon the restoration of power following an electrical outage.
- (b) For 7 days for all other devices.

Displays of date and time shall be in the all numeric format set forth in CAN3-Z234.1.

3-2.8.1 Readability. Any digital electronic display shall be readily readable under normal conditions of use. The minimum height of the metered quantity displayed shall be 5 mm.

3-2.8.2 Resolution. A minimum of four digits shall be provided to display a measured energy quantity. A minimum of three digits shall be provided to display demand. Cumulative or continuous cumulative demand shall be displayed by at least four digits.

3-2.8.3 Codes And Duration Of Display. If one digital display is used to display several quantities, an indication code shall be provided to identify each quantity displayed. If the codes are other than recognized engineering units, they shall be listed on the nameplate or otherwise displayed.

3-2.8.4 When not controlled by an operator, the minimum display time shall be 6 seconds.

3-2.8.5 Battery Carry-over. A device fitted with an electronic register or other display means, the information of which could be lost in the event of a power outage, shall be fitted with a battery carry-over feature to prevent the loss of the display information over the temperature range specified for the device over the following minimum intervals:

(i) For 24 hours for a device which automatically recharges the standby battery upon restoration of power following an electrical outage.

(ii) For 7 days for all other devices.

3-2.8.6 Date and Time Format. Displays of date and time shall be in the format set forth in CAN3-Z234.4 unless otherwise clearly marked.

3-3 ELECTRICAL REQUIREMENTS

3-3.1 Adjustability. The number and range of adjustments has not been specified so as not to restrict design. However, the design shall be such that there is reasonable assurance that when means for adjustment are provided it will be possible to adjust to correct registration at any time during normal lifetime.

3-3.2 Voltage Ratings.

3-3.2.1 Preferred Ratings. Preferred voltage ratings shall be 69, 120, 240, 277, 345, 480 and 600V.

3-3.2.2 Preferred Auxiliary Rating. The preferred auxiliary power supply rating shall be 120V; 60 Hz.

3-3.3 Temperature Rise. The current circuits shall be capable of meeting the temperature rise requirements set forth in CSA Standard C17.

3-3.4 Dielectric Tests. The dielectric tests set out below shall be performed on all devices having input, output or auxiliary circuits rated at 40 volts or more unless the manufacturer specifically states that such tests are not to be performed. The tests are not to be performed on instrument transformers.

Unless otherwise stated, these tests shall be performed between each terminal, rated at 40 volts or more, and ground with all other isolated circuits grounded.

Meters and devices shall be such that they retain adequate dielectric qualities under normal conditions of use. Where applicable, tests shall be carried out on a complete meter with cover and terminal cover in place.

Where applicable, the a.c. voltage test shall be performed before the impulse voltage test.

During the tests, no flashover, disruptive discharge or puncture shall occur.

After these tests, there shall be no change in the percentage error of the meter greater than the uncertainty of the measurement.

3-3.4.1 A.C Voltage. Test. The test voltage, unless otherwise specified, shall come from a 500 VA source, and be a substantially sinusoidal voltage of 1.5 kV rms at 60 Hz applied for one minute between the outside case and the input and output conductors which are rated at 40 V or greater. If the conductors have protective varistors connected between them and ground, the links to the ground may be opened during this test. If the varistors cannot be easily disconnected, this test may be waived.

3-3.4.2 Impulse Voltage Test. The waveform shall be the standardized 1.2/50 microseconds with a peak value of 5000 V. For each test, the impulse voltage shall be applied ten times with the same polarity in both the transverse and the common modes at a repetition rate no greater than one pulse every 3 seconds. The test shall be repeated with the polarity of the pulses reversed.

3-3.4.3 Surge Withstand Capability (SWC) Test. The SWC test shall only be performed on solid state devices having circuits rated at 40V or more.

The SWC test wave shall be an oscillatory wave of frequency range from 1.0 MHz to 1.5 MHz with a voltage range from 2.5 kV to 3.0 kV crest value of the first cycle peak, and having an envelope decaying to 50% of the crest value of the first peak in not less than 6 microseconds from the start of the wave.

The source impedance of the surge generator used to produce the test wave shall be 150 ohms. The test wave shall be applied to the test specimen at a repetition rate of not less than 50 tests per second for a period of not less than 2.0 seconds.

For the duration of the test the meter or device shall be connected or energized in its normal configuration. The input voltage and supply circuits shall be energized at approximately 20% of rated maximum current.

Schematics indicating points of application are shown in Fig. 1.

Note: Further details of this SWC test may be found in IEEE Std. 472/ANSI C37.90 a.

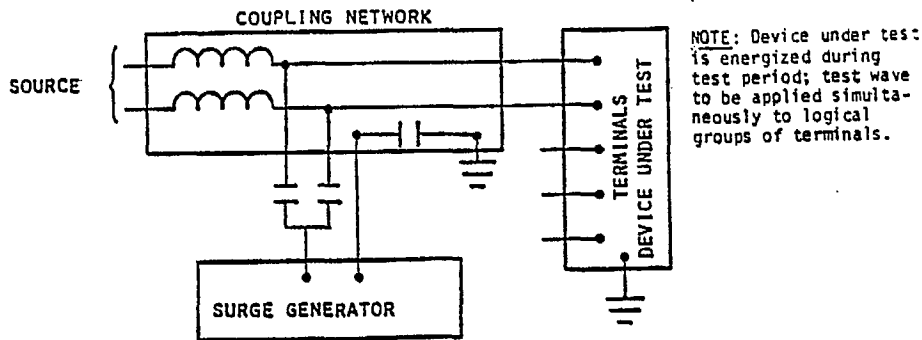

Fig. 1.A. Points of application for the SWC Common Mode Test

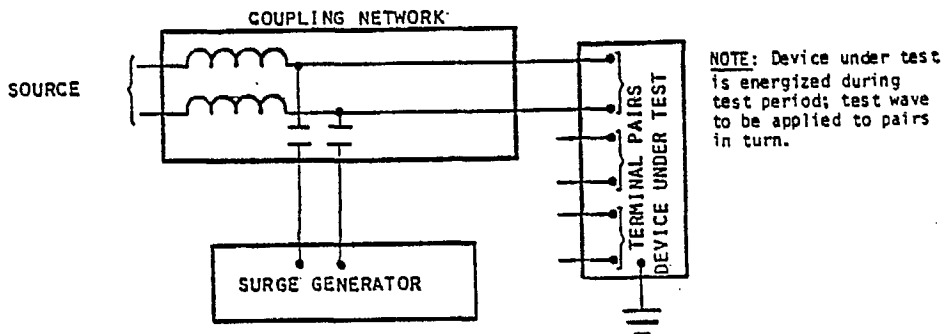

Fig. 1.B. Points of application for the SWC Transverse Mode Test

3-3.5 Carry-Over Time Base. A device used as a master timing reference for other devices, or used in time-of-use metering and not having access to external timing information shall have a battery carry-over feature to maintain the timing reference over the temperature range specified for the device over the following minimum intervals.

a) For 24 hours for a device which automatically recharges the standby battery upon the restoration of power following an electrical outage.

b) For 7 days for all other devices.

The carry-over time base shall be accurate to within +30 seconds over a period of 7 days.

3-3.6 Communications Security. With some devices, it is possible via a communications system, to reset the data or to alter program stored within the device. Subject to requirement 13-6.3 any such device shall be password protected. This means the proper password or security code must be given to gain access to any data that is reset by means of the communications channel.

3-3.7 Battery Condition Indicator. Any unit fitted with a carry-over battery shall also be fitted with a device to indicate the condition of the battery.

3-4 MARKINGS

3-4.1 Nameplates. Every meter, instrument or device shall have the following details indelibly and distinctly marked on one or more nameplates attached in such a way as to be clearly visible from the front, with all covers in place:

- i) Name or mark of manufacturer
- ii) Type or designation
- iii) Serial number
- iv) Departmental approval number
- *v) Operating temperature range

***NOTE:** These requirements shall only apply if the operating range is less than -40°C to $+53^{\circ}\text{C}$. (i.e. intended for temperature controlled locations.)

Additional marking requirements applicable to various types of meters and devices are set forth in subsequent sections specific thereto.

3-4.2 Nameplate Location. It is preferred that the nameplate be attached to the base or meter mechanism; however, it may be attached to the cover or scale provided that in such cases, the serial number is also permanently and predominantly marked on the measuring element or base. Under no circumstances shall the nameplate be mounted on the terminal cover.

3-5 PERFORMANCE REQUIREMENTS

3-5.1 Reference Conditions for Tests. Except when stated otherwise hereinafter, the following reference test conditions shall apply:

- i) the ambient temperature shall be $23^{\circ}\text{C} \pm 2^{\circ}\text{C}$
- ii) the distortion factors of the supply voltage(s) and current(s) shall not exceed 2%
- iii) the supply shall be at rated frequency $\pm 0.2\%$
- iv) the voltage shall be the rated voltage $\pm 0.5\%$
- v) there shall be no significant external magnetic field
- vi) all voltage circuits shall be connected in parallel and all current circuits shall be connected in series assisting
- vii) before any tests are made the voltage circuits shall have been energized for at least one hour
- viii) test currents shall be set progressively to increasing or decreasing values and the current circuits shall be energized at each value for a sufficient time to obtain thermal stability
- xi) the meter or device shall be in its normal working condition. Except where the nature of the test requires otherwise, all registers, transmitting contacts, detents, etc., shall be operating in the normal state. For cyclometer-type registers, only the fastest moving counter shall be turning.
- x) for tests to determine the effect of ambient temperature variation, before commencing tests, the meter shall be subjected to each required value of ambient test temperature for length of time necessary to establish thermal stability.

3-5.2 EMI Susceptibility.

3-5.2.1 Where so specified in the appropriate section, meters and devices shall be subject to tests to establish susceptibility to electromagnetic interference (EMI tests). The requirements are set forth in sub-clauses 3-5.2.2 and 3-5.2.3 below.

Further details relating to these tests may be found in MIL-STD-461B.

3-5.2.2 Conducted Susceptibility. The device shall not exhibit any malfunction or degradation of performance when test spikes each having the waveform shown in Fig 2 are superimposed on the power supply voltage. Pulse repetition rate shall be 10 spikes per second and the duration of the test shall be 10 minutes.

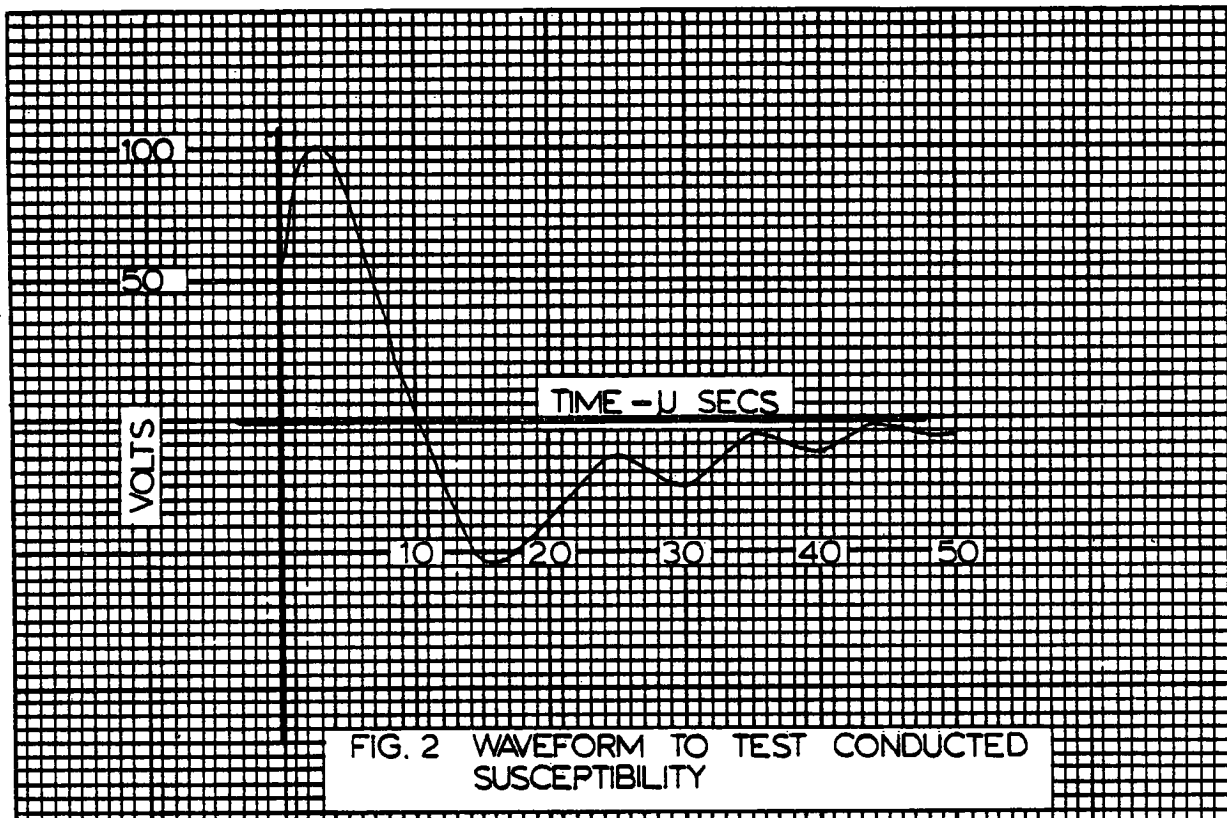

3-5.2.3 Radiation Susceptibility. The device shall not exhibit any malfunction or degradation of performance when subjected to an electric (E) field over the spectrum of 14 kHz to 1 GHz while located in a chamber designed to attenuate reflected radiation. The field without the device being present shall have a field strength of nominally 5 volts per metre over the frequency spectrum. Above 30 MHz, the device shall be tested for sensitivity to both horizontally and vertically polarized waves.

3-5.3 Effects of Ambient Temperature. All devices intended for outdoor use, i.e. for use in locations lacking temperature control, shall be tested from -40°C to $+53^{\circ}\text{C}$ and shall perform according to the requirements set out in the applicable section of these specifications.

Device intended for temperature controlled locations shall be tested over the temperature range stated on the nameplate. Where the tolerances set out in subsequent sections of these specifications apply to the temperature range of -40° to $+53^{\circ}\text{C}$, they shall be prorated according to the range stated on the nameplate for devices intended for a narrower temperature range.

3-5.4 Reverse Operation. Any indication or registration of power or energy shall be in conformance with the direction of the energy flow through the meter. The meter shall be tested over a four hour period at maximum load, and any registration or an excess of one pulse generated indicating energy flowing in the reverse direction shall not be permitted.

SECTION 4 - INDUCTION-TYPE WATT HOUR METERS

CONTENTS

	Page
4-1 SCOPE	24
4-2 MECHANICAL REQUIREMENTS	24
4-2.1 Rotor	24
4-2.2 Registers	25
4-3 ELECTRICAL REQUIREMENTS	26
4-3.1 Connections	26
4-3.2 Test Links	26
4-3.3 Maximum Rated Current	26
4-3.4 Insulation	27
4-4 MARKINGS	27
4-5 PERFORMANCE REQUIREMENTS	28
4-5.1 Reference Conditions for Tests	28
4-5.2 Test Currents and Test Points	28
4-5.3 Adjustment Prior to Tests	29
4-5.4 Creep	30
4-5.5 Load Performance	30
4-5.6 Performance of Individual Current Circuits	31
4-5.7 Polyphase Energization	32
4-5.8 Effect of Voltage Variation	33
4-5.9 Starting	33
4-5.10 Effect of Variation of Frequency	33
4-5.11 Effect of Variation of Ambient Temperature	34
4-5.12 Effect of External Magnetic Field	34
4-5.13 Effect of Momentary Overload	35
4-5.14 Effect of Register Friction	36
4-5.15 Effect of Self-Heating	36
4-5.16 Effect of Tilt	36
4-5.17 Effect of Current Surge	36
4-5.18 Interdependence of Adjustments	37

SECTION 4 - INDUCTION-TYPE WATT HOUR METERS

4-1 SCOPE

These specifications apply to induction-type watt hour meters.

These specifications also apply to components of combination devices utilizing the essential elements of induction-type watt hour meters insofar as their application is practicable.

4-2 MECHANICAL REQUIREMENTS

4-2.1 Rotor

4-2.1.1 Direction of Rotation. Viewed from above, the direction of rotation of the disc shall be counterclockwise. If the disc is visible from the front of the meter, the direction of rotation shall be clearly indicated by an arrow.

4-2.1.2 Markings

4-2.1.2.1 Markings for Rotation Counting. If the disc is visible from the front of the meter, the edge and upper surface of the disc shall carry a conspicuous permanent mark. A companion mark, known as a rotation index mark shall be located on the nameplate, register, frame or magnet in such a manner as to facilitate revolution counting. Other marks may be added for stroboscopic or other tests, but such marks shall be so placed as to not interfere with the use of the main visible marks for revolution counting.

4-2.1.2.2 On self-contained single-phase meters, the disc shall carry the following markings, in black:

On the upper periphery, one hundred divisions, with every fifth division longer than the others, and every tenth division identified consecutively by the figures 10, 20, ... 90.

4-2.1.3 Provision for Photoelectric Testing. For single phase meters, two holes in the rotor disc shall be provided for photoelectric calibration. These shall be 180 degrees apart and at equal distance from the disc centre. If possible, the arrangement shall be such as to permit photo-electric testing with cover in place. For polyphase and combination meters this same provision is desirable but not mandatory.

4-2.2 Registers.

4-2.2.1 Register Ratio. The register indication shall be strictly in accord with the result computed from the number of disc revolutions, the disc constant as given on the nameplate and with the multiplier.

The register ratio shall be permanently marked on the register in such a manner that it is legible without removing the register. If sufficient space is available, the register ratio shall be marked on the register faceplate.

4-2.2.2 Number of Dials or Drums. Self contained single-phase meters with a maximum rated current of 100 A or larger shall, exclusive of the test dial, have 4 dials plus a multiplier or shall have 5 dials with or without a multiplier.

4-2.2.3 Test Dials. With the exception of meters with a multi-rate register, all single phase meters shall be provided with a special test dial for testing the register. In the case of polyphase meters, if the lowest reading dial or drum requires more than one hour to make one complete revolution when the meter under single phase conditions specified in 3-5.1 (vi), is running on maximum load or 100 A whichever is lesser, a test dial shall be provided.

The pointer of the test dial shall rotate at ten times the speed of the lowest reading dial or drum. It shall be located out of line with the other dials or be distinctly different in appearance. There shall be no figures on the test dial but it shall be divided into ten equal divisions. The direction of rotation shall be indicated by means of an arrow.

4-2.2.4 Backlash. The backlash in a register shall not exceed one-half of a division of the test dial or that dial which indicates the smallest increments of energy, unless the backlash can be taken up by running the meter for not more than 20 seconds at maximum load.

4-3 ELECTRICAL REQUIREMENTS

4-3.1 Connections. The voltage circuit, if connected internally, shall be connected on the supply side of the current circuit.

4-3.2 Test Links. All self-contained polyphase meters shall be provided with test links by means of which the voltage circuits may be isolated from the current circuits for test purposes without removing the cover.

4-3.3 Maximum Rated Current. The maximum current rating of the meter shall not be greater than that imposed by the following restriction:

The speed of the disc shall not exceed 120 revolutions per minute. when the meter is operating with maximum current in all current circuits and with all voltage circuits energized at rated voltage and unity power factor. For polyphase meters, the applied voltages and currents shall be polyphase and balanced.

4-3.4 Insulation. The insulation shall be capable of withstanding:

(a) The a.c. voltage test described in subclause 3-3.4.1 using 2.5 kV rms applied between;

- i) The grounded parts and coupled current and voltage circuits, and
- ii) The individual current circuits of multiple current circuit meters.

(b) The impulse voltage test described in subclause 3-3.4.2 applied between;

- i) All line terminals in pairs, and
- ii) The grounded parts and all terminals coupled together.

4-4 MARKINGS

In addition to the requirements of subsection 3-4, every meter shall have the following details indelibly and distinctly marked on one or more nameplates attached in such a way as to be clearly legible from the front, with all covers in place.

- i) Rated Frequency
- ii) Rated voltage or voltages
- iii) Minimum and maximum rated currents
- iv) Disc constant
- v) One of the following
 - 1-phase, 2-wire
 - 1-phase, 3-wire
 - 2-element
 - 2 $\frac{1}{2}$ -element wye
 - 2 $\frac{1}{2}$ -element delta
 - 3-element wye
- vi) For single phase transformer type meters, the word "Transformer Type" in red
- vii) For transformer rated meters, also
 - 1) Primary disc constant
 - 2) Current transformer rating, e.g. 1000-5A
 - 3) Voltage transformer rating, e.g. 2400-120V

Note 1: Accepted symbols are \emptyset , EL, Y, Δ .

Note 2: For 2½ element wye and 3 element meters, rated voltage is phase to neutral voltage.

Space shall be provided for affixing the inspection number.

If the meter is fitted with accessories such as a reverse running detent, re-transmitting contacts, etc., this shall be specified on the nameplate or on an auxiliary plate, and a diagram of connections shall be provided if considered necessary by the director. Recognized symbols are acceptable.

4-5 PERFORMANCE REQUIREMENTS

4-5.1 Reference Conditions for Tests. Unless stated otherwise hereinafter, adjustment and tests shall be performed under the following reference conditions:

- i) the conditions stated in clause 3-5.1
- ii) the meter mounted in its normal working position with the disc within 0.5° of truly horizontal.

4-5.2 Test Currents and Test Points. Test currents referred to in this and following sections shall be as stated in Table 2.

TABLE 2

TEST CURRENTS FOR INDUCTION WATT HOUR METERS

Designation	Current	Remarks
	Range-Rated Meters % Maximum	
TC-1	Minimum Rated	
TC-2	2.5	I for Ref. LL Speed*
TC-3	5	
TC-4	25	Ref. HL I
TC-5	50	
TC-6	75	
TC-7	100	

* Reference low-load speed is a test point; see Section 2 - DEFINITIONS.

Test points stated hereinafter shall be at the stated test current, e.g., TC-5 and unity power factor, unless the test current designation is followed by the abbreviation Pf, eg., TC-5 Pf, and then the test power factor shall be 0.5 lag.

4-5.3 Adjustment Prior to Tests. Before commencing performance tests, the calibration shall be corrected, as nearly as practicable, to 100% registration.

In addition, polyphase meters shall be adjusted for minimum difference in registration when each current circuit is energized separately (balance test).

The calibration points, and limits of allowable deviation shall be as given in Table 3.

**TABLE 3
TEST POINTS FOR PRIOR ADJUSTMENTS**

Test	Applies To	Test Point	Allowable Deviation % Registration
High Load	All meters	TC-4	+0.1% from true registration
Low Load	All meters	TC-2	+0.2% from registration at TC-4
Power Factor	1-Phase	TC-4 Pf	+0.5% from registration at TC-4
	Polyphase	TC-4 Pf	+0.3% from true registration
Balance*	Multi-element meters	TC-4 each element separately	+0.3% from registration for each other element

* Does not apply to the split coil of a 2½-element meter.

4-5.4 Creep. With no current in any current circuit, the disc shall not make one complete revolution within a ten minute interval when any voltage from 80% to 120% of rated voltage is applied. For polyphase meters, a polyphase voltage of proper phase sequence shall be applied.

4-5.5 Load Performance. With all circuits energized the meter shall be tested for accuracy with variation in load current, and the percentage errors shall not exceed those given in Table 4.

TABLE 4
ALLOWABLE LIMITS OF ERROR

Test Points	Maximum Allowable Error
TC-1 and TC-2	<u>+1.5%</u>
TC-3, TC-4, TC-5	<u>+0.75%</u>
TC-6, TC-7*	<u>+1.5%</u>
TC-2 Pf, TC-3 Pf, TC-4 Pf	<u>+1.5%</u>
TC-5 Pf, TC-6 Pf, TC-7 Pf*	<u>+2.0%</u>

*Delete for 2 $\frac{1}{2}$ -element wye meters.

4-5.6 Performance of Individual Current Circuits.

4-5.6.1 Single-Phase Meters, Equality of Current Circuits. For 3-wire meters the percentage registration shall be determined with each current coil energized separately in turn. The test points shall be TC-3, TC-5 and TC-5 Pf. The difference between the two values of percentage registration obtained for the two current circuits at any one test point shall not exceed 2.0%.

4-5.6.2 Polyphase Meters, Equality of Current Circuits. The difference between the registration for any one current circuit and that for any other current circuit shall not exceed 1.5% at any current from TC-2 to TC-4, unity power factor. The limit shall apply after correcting the unbalance observed when the meter was adjusted if required, prior to testing, at TC-4 (clause 4-5.3).

In addition the 3-wire element of a $2\frac{1}{2}$ -element delta meter shall be treated as a single-phase 3-wire meter. Sub-clause 4-5.6.1 shall apply.

4-5.6.3 Polyphase Meters, Variation of Load. The percentage registration shall be determined for each current circuit energized separately in turn. The test points shall be as stated hereinafter. For 2-element and 3-element meters, the percentage errors shall not exceed those stated in Table 5.

A $2\frac{1}{2}$ -element wye meter shall be treated as a 3-element polyphase meter.

A $2\frac{1}{2}$ -element delta meter shall be treated as a 2-element polyphase meter after connecting the current circuits of the 3-wire element in series.

TABLE 5

ALLOWABLE LIMITS OF ERROR

POLYPHASE METERS - INDIVIDUAL ELEMENTS

Test Point	Max. Allowable Error
TC-3, TC-4	<u>+1.5%</u>
TC-3 Pf, TC-4 Pf	
TC-5, TC-7	+3.0%, -2.0%
TC-5 Pf, TC-7 Pf	

4-5.7 **Polyphase Energization.** Polyphase meters shall be tested for accuracy with balanced polyphase voltages and currents. The test points and allowable limits of error shall be as given in Table 6.

TABLE 6

ALLOWABLE LIMITS OF ERROR FOR POLYPHASE TESTS

Test Points	Max. Allowable Error
TC-7	<u>+2%</u>
TC-4	<u>+0.75%</u>
TC-2	<u>+1%</u>
TC-1	<u>+2%</u>

In addition, the same tests shall be carried out with the phase sequence of the supply reversed. The same error limits shall apply. Where a definite phase sequence is specified for a meter, the test with phase sequence reversed is not required.

4-5.8 Effect of Voltage Variation. With the test current constant, a variation of the applied voltage of up to 10% above and below the rated (reference) voltage shall not affect the percentage registration by more than the values specified in Table 7.

Where the meter is rated with a voltage range, e.g. 115-120 V, the deviation limits shall apply from 10% below the lower voltage rating to 10% above the higher voltage rating.

TABLE 7
LIMITS OF EFFECT OF VOLTAGE VARIATION

Meter	Test Points	Maximum Allowable Deviation from Registration at Rated voltage
Single Phase	TC-2, TC-4, TC-7	+1.0%
	TC-2 Pf, TC-4 Pf, TC-7 Pf	+1.5%
Polyphase	TC-2, TC-4, TC-6	+1.0%
	TC-3 Pf, TC-6 Pf	+1.5%

4-5.9 Starting. The rotor shall start and continue to rotate with load current as follows:

For meters without auxiliary devices: 0.125% of I_{max} .

For meters with auxiliary devices: 0.25% of I_{max} .

For the purpose of this clause, auxiliary device means a device such as a reverse running detent or re-transmitting contact which by its nature tends to increase the minimum starting torque.

4-5.10 Effect of Variation of Frequency. At TC-4, a change of +5% from the rated frequency shall not cause a change in percentage registration of more than +1.0%.

4-5.11 Effect of Variation of Ambient Temperature.

4-5.11.1 Meters intended for outdoor service. Percentage registration tests shall be carried out at sustained ambient temperature of -40°C , -7°C , reference temperature, and 53°C . The test points and maximum allowable temperature influence shall be as stated in Table 8.

TABLE 8
EFFECT OF AMBIENT TEMPERATURE VARIATION

Ambient Temperature	Test Points	Max. Allowable Difference Between Registration At Test Temperature and At Reference Temperature
-7°C & 53°C	TC-2 & TC-4	$\pm 1.0\%$
	TC-4 Pf	$\pm 2.0\%$
-40°C	TC-2 & TC-4	$\pm 3.0\%$
	TC-4 Pf	$\pm 4.0\%$

4-5.11.2 Meters designated as being intended for a limited temperature range. For meters intended for indoor use only and which have been assigned a specific temperature range, the temperature influence shall not exceed the following limits:

Test Points	Max. Allowable Temperature Coefficient Over Specified Range
TC-2, TC-4	$0.04\% / ^{\circ}\text{C}$
TC-4 Pf	$0.06\% / ^{\circ}\text{C}$

4-5.12 Effect of External Magnetic Field. The percentage registration shall be determined with and without the meter subjected to an external magnetic field.

The field shall be equivalent to that produced by a coil one meter in diameter having a magnetomotive force of 400 ampere turns. The frequency of the coil current shall be the same as that applied to the meter. The phase of the coil current and the orientation of the coil shall be such as to produce a maximum effect. For polyphase meters, the test voltage and currents shall be balanced polyphase.

The influence of the external magnetic field at TC-4 shall not exceed +2.0%.

4-5.13 Effect of Momentary Overload. Under reference conditions (clause 4-5.1), percentage registration shall be determined at test points TC-2, TC-4, and TC-4 Pf, before and after subjecting the meter to an overload current of magnitude and duration as stated in Table 9. The overload current shall pass through all current circuits connected series assisting.

Following the overload application, the meter shall remain one hour with only the voltage circuits energized before testing. The change in percentage registration shall not exceed the values shown in Table 9.

TABLE 9

EFFECT OF MOMENTARY OVERLOAD

Meter Type	Overload Current	Duration	Maximum Permissible Effect
Self-Contained	Peak value 50 times maximum rated or 7000A, whichever is less.	0.1 s	1.0%
Transformer Type	10 times maximum rated	0.5 s	0.5%

4-5.14 Effect of Register Friction. The change in error after removal of a clock type register shall not exceed 0.5% at TC-2. For cyclometer type registers, the maximum effect of friction including that at turnover through zero, shall not be greater than 1.0% at TC-2.

4-5.15 Effect of Self-Heating. The effect of a sustained load applied for four hours shall not change the percentage registration by more than the following:

TC-4	-	<u>+1.0%</u>
TC-4 Pf	-	<u>+1.5%</u>
TC-7	-	<u>+1.0%</u>

The reference registration for these tests shall be the registration determined within 2 minutes of application of test current.

4-5.16 Effect of Tilt. Tilting a meter up to 3° from the vertical shall not affect the percentage registration at TC-2 by more than 1.0%.

For test purposes, the four positions of the tilt are specified as forward, backward, left and right. The position of true verticality shall be determined by using the plane of the stationary disc as the reference.

4-5.17 Effect of Current Surge. The meter shall be subjected to the effects of a transient surge of 20000 A crest, (20 x 50 microsecond wave) through a conductor positioned vertically 4 cm behind the flat portion of the base of the meter, with a socket in place. The effect of the current surge on the registration at TC-4 shall not exceed +1.0%. This test shall apply only to S-base meters with maximum rated current 100 A or higher.

4-5.18 Interdependence of Adjustments. Where applicable, making a light load adjustment sufficient to change the percent registration at TC-2 by 2% shall not affect the registration at TC-4 Pf by more than 0.8%.

Where applicable, making an inductive load adjustment sufficient to change the percent registration at TC-4 Pf by 1% shall not affect the registration at TC-2 by more than 0.5%.

SECTION 5 - INDUCTION TYPE VAR HOUR AND Q-HOUR METERS

CONTENTS

	Page
5-1 SCOPE	39
5-2 CLASSIFICATION.	39
5-3 MECHANICAL REQUIREMENTS	39
5-4 ELECTRICAL REQUIREMENTS	40
5-4.1 General	40
5-4.2 Disc and Test Constant	40
5-5 MARKINGS	40
5-6 PERFORMANCE REQUIREMENTS FOR CLASS 90 METERS	40
5-7 PERFORMANCE REQUIREMENTS FOR CLASS 0 OR 60 METERS	40
5-7.1 Reference Conditions for Tests	40
5-7.2 Test Currents	41
5-7.3 Adjustment Prior to Tests	41
5-7.4 Creep	42
5-7.5 Performance with Variation of Load	42
5-7.6 Effect of Variation of Voltage	44
5-7.7 Starting	45
5-7.8 Effect of Variation of Ambient Temperature	45
5-7.9 Miscellaneous	46

SECTION 5 - INDUCTION TYPE VAR HOUR AND Q-HOUR METERS

5-1 SCOPE

These specifications apply to induction-type var hour and Q-hour meters. These specifications also apply to components of combination devices utilizing the essential elements of induction-type var hour or Q-hour meters.

5-2 CLASSIFICATION

For test purposes, var hour and Q-hour meters shall be classified by the nominal phase displacement between the voltage and current magnetic fluxes in the principal air gap of a single driving element when the voltage and current applied to this single driving element are in phase. Var hour and Q-hour meters are generally either of class 0, 60, or 90.

Note (1): "Driving element" here includes any necessary accessory resistors, inductors and shunts.

Note (2): A watt hour meter driving element is class 90.

5-3 MECHANICAL REQUIREMENTS

The requirements of subsections 3-2 and 4-2, where applicable, shall apply.

5-4 ELECTRICAL REQUIREMENTS

5-4.1 General. The requirements of subsections 3-3 and 4-3, shall apply.

5-4.2 Disc and Test Constant. For polyphase class 90 var hour or Q-hour meter, the ratio of any two constants, k_h and K_{wh} and K_{tc} , shall be within 0.10% of the calculated value for an ideal meter.

5-5 MARKINGS

In addition to the requirements of subsections 3-4 and 4-4, every meter shall have the following details indelibly and distinctly marked in such a way as to be clearly visible from the front, with the cover in place:

- i) Var hour or Q-hour disc constant.
- ii) For class 90 polyphase meters, either
 - (a) single-phase test constant, or
 - (b) single-phase watt hour constant, K_{wh} .

5-6 PERFORMANCE REQUIREMENTS FOR CLASS 90 METERS

For performance tests, class-90° meters shall be treated as watt hour meters. Subsection 4-5 shall apply with the following change. In clause 4-5.2 the abbreviation, Pf, shall signify a test power factor of 0.5 lead. The voltage and current sources in such a manner that the meter registers energy in kilowatt hours.

5-7 PERFORMANCE REQUIREMENTS FOR CLASS 0 AND 60 POLYPHASE VAR HOUR AND Q-HOUR METERS

5-7.1 Reference Conditions for Tests. Unless stated otherwise hereafter, adjustment and tests shall be performed under the following reference conditions:

- i) the conditions stated in clause 3-5.1,
- ii) the meter mounted in its normal working position with the disc within 0.5° of truly horizontal,
- iii) the phase displacement between test voltage and test current to produce maximum torque.

5-7.2 Test Currents. Values given in Table 2 of clause 4-5.2 shall apply. Unless stated otherwise the test voltage and current shall have a phase displacement such as to produce maximum torque¹. Where the test current designation is followed by the abbreviation Pf, e.g. TC-4 Pf, the phase displacement between test voltage and test current shall be such as to produce 50% of maximum torque².

Note 1: For a class 60 meter the test current would lead the test voltage by 30° .

Note 2: For a class 60 meter the test current would lag the test voltage by 30° .

5-7.3 Adjustment Prior to Tests. Before commencing performance tests, meters shall be adjusted as nearly as is practicable to 100% registration under reference conditions, and for minimum difference in registration when each current circuit is energized separately. The calibration points and limits of allowable deviation shall be as given in Table 10.

TABLE 10
ADJUSTMENT PRIOR TO TESTS

Adjustment	Test Current	Allowable Error or Difference
High Load	TC-4	$\pm 0.3\%$
Low Load	TC-2	$\pm 0.2\%$ from that at TC-4
Lag	TC-4 Pf	$\pm 0.3\%$
Balance	TC-4	$\pm 0.3\%$ difference

5-7.4 Creep. With no current in any current circuit, the disc shall not make one complete revolution in a ten minute interval when any voltage from 80% to 120% of rated voltage is applied. For polyphase meters, a polyphase voltage of proper phase sequence shall be applied.

5-7.5 Performance with Variation of Load.

5-7.5.1 Single-phase Energization. With voltage coils energized in parallel and current coils in series, the errors shall not exceed those listed in TABLE 11. With voltage coils in parallel and test currents applied to each current circuit in turn, the errors shall not exceed those stated in TABLE 12. In addition, the difference between the registration for any one coil and that for any other shall not exceed 2%. For $2\frac{1}{2}$ element meters, the split coil element shall be tested by energizing only the appropriate voltage coils in turn.

TABLE 11

Limits of Error - Single Phase Energization
Current Coils in Series

Test Current	Limits of Error
TC-1, TC-5, TC-3 Pf, TC-4 Pf	<u>+3.0%</u>
TC-2 to TC-4 Inclusive	<u>+2.5%</u>

TABLE 12

LIMITS OF ERROR - Single-phase Energization
Current Coils Energized Individually In Turn⁽¹⁾

Test Current	Limit of Error
TC-3 to TC-4 Inclusive	<u>+3.5%</u>
TC-3 Pf, TC-4 Pf	<u>+4.0%</u>

(1) NOTE: A 2½ element wye meter shall have each half of the split coil in conjunction with the respective potential coil treated as a separate element.

5-7.5.2 Polyphase Energization. With balanced polyphase voltages and currents applied the errors shall not exceed those stated in Table 13.

TABLE 13

Limits of Error - Balanced Polyphase Loading

Current % of Maximum	Reactive Factor	Limits of Error
2.5	1.0	<u>+3.0%</u>
20 to 100	1.0	<u>+2.5%</u>
50 to 100	0.5	<u>+2.5%</u>

5-7.6 Effect of Variation of Voltage. With constant test current, variation of the applied voltage of 10% above and below the rated (reference) voltage shall not cause the percentage registration to deviate from that at rated voltage by more than 1.5% when tested at any current from TC-3 to TC-5 inclusive. When the meter is rated with a voltage range, e.g., 115-120 V, the deviation limits shall apply from 10% below the lower voltage to 10% above the higher voltage.

5-7.7 **Starting.** The rotor shall start, and continue to rotate with currents as follows:

For meters without auxiliary devices: 0.1% of I_{max} .

For meters with auxiliary devices: 0.2% of I_{max} .

For the purpose of this clause, auxiliary device means a device such as a reverse running detent or re-transmitting contact which by its nature tends to increase the minimum starting torque.

5-7.8 **Effect of Variation of Ambient Temperature.**

5-7.8.1 Meters intended for outdoor service. Percentage registration shall be determined at sustained ambient temperatures of -40°C , -7°C , reference temperature (clause 3-5.1) and 53°C . The test points and maximum allowable influence shall be as stated in Table 14.

TABLE 14

Effect of Variation of Ambient Temperature

Meters for Outdoor Service

Ambient Temperature	Test Current	Maximum Allowable Difference Between Registration at Test Temperature and that at Reference Temperature
-7°C and $+53^{\circ}\text{C}$	TC-2 to TC-4 TC-4 Pf	$\pm 1.2\%$ $\pm 2.4\%$
-40°C	TC-2 to TC-4 TC-4 Pf	$\pm 3.0\%$ $\pm 5.0\%$

5-7.8.2 Meters designated as being intended for a limited temperature range.

For meters intended for indoor use only and which have been assigned a specific temperature range, the temperature coefficient shall not exceed 0.15% per °C at any current from TC-2 to TC-7 or 0.25% per °C at any current from TC-3 Rf to TC-7 Rf.

5-7.9 **Miscellaneous.** The requirements of clauses 4-5.12 to 4-5.17, inclusive, shall apply, bearing in mind the provisions of clause 5-7.2.

SECTION 6 - STATIC INTEGRATING METERS

CONTENTS

	Page
6-1 SCOPE	48
6-2 ELECTRICAL REQUIREMENTS	
6-2.1 Power Supply	48
6-2.2 Testing	48
6-3 MARKINGS	49
6-3.1 Constants	49
6-3.2 Meters Compensated for Line or Transformers Losses	49
6-4 PERFORMANCE REQUIREMENTS	49
6-4.1 Reactive Energy Meters	49
6-4.2 Adjustments Prior to Tests	49
6-4.3 Reading at Zero Load	49
6-4.4 Load Performance	49
6-4.5 Performance of Individual Current Circuits	50
6-4.6 Polyphase Energization	51
6-4.7 Effect of Voltage Variation	51
6-4.8 Starting	51
6-4.9 Effect of Variation of Frequency	51
6-4.10 Effect of Variation of Ambient Temperature	52
6-4.11 Effect of External Magnetic Field	52
6-4.12 Effect of Momentary Overload	52
6-4.13 Effect of Self Heating	53
6-4.14 EMI Susceptibility	53

SECTION 6 - STATIC INTEGRATING METERS

6-1 SCOPE

These specifications apply to solid state energy meters such as watt hour, var hour, and Q-hour meters.

This specification is written to pertain to devices of this nature which are designed for use with instrument transformers. Should similar devices intended for direct connection be submitted they will be considered in the light of this and other related sections, due discretion being used in the application of the various clauses.

6-2 ELECTRICAL REQUIREMENTS

6-2.1 Power Supply. Preferred power supply rating is 120 V, 60Hz.

6-2.2 Testing. Each meter shall be provided with a testing means to facilitate calibration, (in a manner analogous to counting the disc revolutions of an induction watt hour meter).

Such testing means shall provide at least 5 pulses (or other indications) per minute when the meter is operating at 25% of maximum load under the single phase reference conditions specified in clause 3-5.1.

6-3 MARKING

6-3.1 Constants. Markings shall be as set forth in subsection 4-4 except that for "disc constant", "test constant" shall be substituted.

6-3.2 Meters Compensated for Line or Transformer Losses. Meters which are internally compensated for line or transformer losses shall have "LOSS COMPENSATED" indelibly marked in red on the nameplate.

6-4 PERFORMANCE REQUIREMENT

6-4.1 Reactive Energy Meters. For reactive energy meters, where the term "power factor" appears in this subsection, the term "reactive factor" shall be substituted.

6-4.2 Adjustments Prior to Tests. Before commencing performance tests, the meter shall be adjusted for minimum errors at the following test points:

- i) 25% I_{max} at unity power factor.
- ii) 25% I_{max} at 0.5 power factor.
- iii) 2.5% I_{max} at unity power factor.

In addition, polyphase meters shall be adjusted such that the difference in error between any two elements is minimal at 25% I_{max} .

6-4.3 Reading at Zero Load. With rated voltage and zero current applied and under steady state conditions, there shall be no change in the meter reading over a four hour period.

6-4.4 Load Performance. With all circuits energized the meter shall be tested for accuracy with variation in load current and power factor. The percentage errors shall not exceed those set out in Table 15.

TABLE 15

ALLOWABLE LIMITS OF ERROR

Current	Power Factor	Percentage Error Limit
Any value from min. to max.	1.0	±0.5
Any value from min. to max.	0.5 lag or lead	±0.75

6-4.5 Performance of Individual Current Circuits.

6-4.5.1 Single-Phase Meters, Equality of Current Circuits. For 3-wire meters the percentage registration shall be determined with each current circuit energized separately in turn. The test points shall be 5% I_{max} , 50% I_{max} and 50% I_{max} Pf. The difference between the values of percentage registration for each circuit obtained at any one test point shall not exceed 1.0%.

6-4.5.2 Polyphase Meters, Equality of Current Circuits. The difference between the registration for any one current circuit and that for any other current circuit shall not exceed 0.5% at any current from 2.5% I_{max} to 50% I_{max} inclusive. This limit shall apply after correcting for the unbalance observed when the meter was adjusted, if required, prior to testing, at 50% I_{max} (clause 6-4.2).

6-4.5.3 Polyphase Meters, Variation of Load. The percentage registration shall be determined for each current circuit energized separately in turn. The test points shall be as set forth in Table 16 except that the test current shall, under no circumstances exceed 150 A. For 2-element and 3-element meters, the percentage errors shall not exceed those stated in Table 16.

TABLE 16

ALLOWABLE LIMITS OF ERROR

POLYPHASE METERS - INDIVIDUAL ELEMENTS

VOLTAGE CIRCUITS IN PARALLEL

Any current	Power Factor of the Element Under Test	Percentage Error Limit
Any Current from Min. to Max.	1.0	<u>+0.75</u>
Any Current from Min. to Max.	0.5 lag	<u>+1.0</u>

6-4.6 Polyphase Energization. Polyphase meters shall be tested for accuracy with balanced polyphase voltages and currents. The test points and allowable limits of error shall be as set forth in Table 17.

TABLE 17

ALLOWABLE LIMITS OF ERROR FOR POLYPHASE TESTS

Current	Power Factor	Percentage Error Limit
Any value from min. to max.	1.0	<u>+0.75%</u>
Any value from min. to max.	0.5 lag	<u>+1.0%</u>

In addition, the same tests shall be carried out with the phase sequence reversed. The same error limits shall apply. Where a definite phase sequence is specified for a meter, the test with phase sequence reversed is not required.

6-4.7 Effect of Voltage Variation. A variation of the applied voltage of up to +10% shall not affect the percentage registration by more than 0.2% at 50% I_{max} nor by more than 0.4% at 50% I_{max} at 0.5 Pf. The auxiliary supply voltage shall be varied simultaneously with the metered voltage and by the same percentage.

6-4.8 Starting. The meter shall start and continue to register with unity Pf load current of 0.05% of maximum rated current.

6-4.9 Effect of Variation of Frequency. At 50% maximum current, unity Pf, a variation in frequency of 5% shall not cause a change in percentage registration of more than 0.2%. The frequency of the auxiliary supply voltage shall be varied simultaneously with the meter voltage.

6-4.10 Effect of Variation of Ambient Temperature. The maximum allowable influence on accuracy due to variation of ambient temperature shall be 0.03% per °C.

This influence shall be determined by comparing the registration at 50% I_{max} and at 50% I_{max} 0.5 Pf at 23°C ambient temperature with that at -40°C and at 53°C. If the nameplate indicates a restricted ambient temperature range the requirements will apply only within this range.

6-4.11 Effect of External Magnetic Field. The change in percentage registration at 50% I_{max} shall not exceed +1.0% when the meter is subjected to an external magnetic field. The magnetic field shall be equivalent to that produced by a coil one metre in diameter having a magnetomotive force of 400 ampere-turns. The frequency of the coil current is to be the same as that applied to the meter. The phase of the coil current and the orientation of the coil shall be such as to produce the maximum effect. For polyphase meter, the test voltages and currents shall be balanced polyphase.

6-4.12 Effect of Momentary Overload. With all potential circuits energized and with current circuits connected series assisting, the meter shall be subjected to a current equal to 10 times I_{max} for 0.5 seconds. After the application of this short time over-current, the meter shall be left for one hour with only the potential circuits energized following which the meter shall be tested for variation of error at 50% I_{max} at unity power factor. The variation in error shall not exceed +0.5%.

6-4.13 Effect of Self-Heating. The effect of a sustained load at maximum rated current, unity Pf for four hours shall not change the percentage registration by more than 0.3%.

The reference registration for this test shall be that determined within two minutes of application of test current.

6-4.14 EMI Susceptibility. Meters shall be subject to the EMI susceptibility tests set forth in 3-5.2.

SECTION 7 - DEMAND METERS

CONTENTS

	Page
7-1 SCOPE	55
7-2 MECHANICAL REQUIREMENTS	55
7-2.1 Maximum Demand Indicators	55
7-2.2 Recording Meters	58
7-3 ELECTRICAL REQUIREMENTS	58
7-3.1 Connections	58
7-3.2 Insulation	58
7-3.3 Test Links	59
7-3.4 Maximum Current Rating	59
7-3.5 Full-Scale Demand Rating	59
7-3.6 Demand Interval or Response Period	59
7-4 MARKINGS	59
7-5 PERFORMANCE REQUIREMENTS	60
7-5.1 Integrating Demand Meters	60
7-5.2 Thermally Lagged Demand Meters	61

SECTION 7 - DEMAND METERS

7-1 SCOPE

These specifications apply to demand meters of recording, lagged or integrating type, used for the measurement of demand in watts, volt amperes, vars, or Q^* .

They do not apply to transducers, null balancing instruments, magnetic or paper tape recorders, nor to solid state demand meters.

7-2 MECHANICAL REQUIREMENTS

7-2.1 Maximum Demand Indicators.

7-2.1.1 Pointer and Scale Indicators.

7-2.1.1.1 General. Where applicable, the clearance between the portion of the pointer which traverses the scale and the scale itself shall not exceed 2.5 mm nor be less than 1.1 mm.

The driving pointer, if it can be read when in contact with the driven pointer, shall indicate the same reading as the driven pointer.

***Note:** Q is a quantity that may be measured by effectively lagging the applied voltage to a watt meter by 60° .

The driving pointer shall be of a colour distinctly different from that of the driven pointer.

The driving pointer shall not at any time, interfere with clear reading of the driven pointer indication.

7-2.1.1.2 Damping. There shall be sufficient damping to ensure that when disengaged from the driving pointer, the driven pointer will remain in the correct reading position, unaffected by such vibration as may be encountered in normal service.

For grease-damped pointers -

(a) With driving and driven pointers in the steady-state in-contact position:

(i) tapping the meter shall not cause the indication to increase by more than 1.0% of full scale.

(ii) removal of the load shall not cause the driven pointer to be pulled back by more than 1.0% of full scale.

(b) With driving pointer disengaged, tapping the meter shall not cause the driven pointer to change position by more than 1% of full scale.

7-2.1.1.3 Reset Device. This device shall be such that, in its normal position, it does not affect either the maximum demand indicator or the driving element. Means shall be provided for sealing the reset device in this position. Resetting of the maximum demand indicator shall only be possible either after breaking the seal or with a special tool.

It shall not be possible to move the maximum demand indicator up-scale by means of the reset device.

7-2.1.1.4 Reset Time. The reset time shall not exceed 1.0% of the demand interval, or 15 s whichever is the lesser.

The reset time shall be included in the demand interval.

7-2.1.1.5 Scales. Minimum scale length shall be as follows:

For thermal meters: 90 mm

For integrating demand meters: 150 mm.

7-2.1.2 Clock Type Maximum Demand Indicators.

7-2.1.2.1 General. All clock-type indicators shall have at least three dials.

The minimum diameter of clock dial circles shall be 10 mm.

Each dial shall be divided into ten equal and clearly numbered divisions. Preferably dials shall be distinctly separated from each other. The lowest reading dial shall be on the right and shall rotate in a clockwise direction viewed from the front. The gearing shall be such that a complete revolution of any pointer shall cause the adjacent pointer to the left to advance one division.

7-2.1.2.2 Cumulative Clock-Type Maximum Demand Indicators.

Cumulative clock-type indicators shall have at least four dials.

The value represented by the smallest division of the dial with the fastest moving pointer shall not be more than one percent of full scale.

7-2.1.3 **Cyclometer-Type Maximum Demand Indicators.**

7-2.1.3.1 **General.** All cyclometer-type demand indicators shall have at least three digits.

All windows in the demand indicator face shall lie in a straight horizontal line and be of the same size. The size and shape of the numerals shall be such that they are clearly legible.

The arrangement of the cyclometer drums and the cutouts in the demand-indicator face shall be such that, with the exception of the fastest moving drum, one and only one digit is in full view at all times except when the drum is advancing from one position to the next.

7-2.1.3.2 **Cumulative Cyclometer-Type Maximum Demand Indicators.** All cumulative-type demand indicators shall have at least four digits.

The value represented by the lowest value digit (right hand viewed from the front) shall not be more than one percent of full scale.

7-2.2 **Recording Meters.**

7-2.2.1 **Chart width.** The minimum chart width shall be 110 mm.

7-2.2.2 **Scales.** When a recording meter is provided with a scale, the graduations thereon must be essentially identical to those on the chart.

7-3 ELECTRICAL REQUIREMENTS

7-3.1 **Connections.** The voltage circuit, if connected internally shall be connected on the supply side of the current circuit.

7-3.2 **Insulation.** The insulation shall meet the requirements of clause 4-3.4.

7-3.3 Test Links. With the exception of single phase integrating demand meters all self-contained meters shall be provided with test links by means of which the voltage circuit(s) may be isolated from the current circuit(s) for test purposes, without removing the cover.

7-3.4 Maximum Current Rating. The maximum rated current shall in no case be less than 50 times the minimum rated current.

7-3.5 Full-Scale Demand Rating. The full-scale demand rating shall conform to the limits given in Table 18.

TABLE 18
DEMAND METER FULL-SCALE LIMITS

Meter	Full-Scale Value	
	Lower Limit	Upper Limit
Single-Phase	$0.5 \times V \times I_m$	$1.05 \times V \times I_m$
2 el. & 2½ el. delta	$0.5 \times V \times I_m \times \sqrt{3}$	$1.05 \times V \times I_m \times \sqrt{3}$
Network	$0.5 \times V \times I_m \times 2$	$1.05 \times V \times I_m \times 2$
2½ el. & 3 el. Y	$0.5 \times V \times I_m \times 3$	$1.05 \times V \times I_m \times 3$

V = Rated Voltage
I_m = Maximum Rated Current.

7-3.6 Demand Interval or Response Period. The demand interval or response period shall be not less than 15 minutes.

7-4 MARKINGS

Nameplate Marking. In addition to the requirements of subsection 4-4, demand meter nameplates shall bear the following information:

- i) Rated frequency
- ii) Rated voltage or voltages
- iii) Current range or rating
- iv) Response period or demand interval
- v) Full-Scale demand rating
- vi) Single-Phase test constant (if applicable)
- vii) One of the following:
 - 1-phase, 2-wire,
 - 1-phase, 3-wire,
 - 2-element
 - 2-element network
 - 2-element, 3-phase, 3-wire
 - 2½-element wye
 - 2½-element delta
 - 3-element wye

Note: Accepted symbols are \emptyset , EL, Y, Δ .

- viii) All information essential for determination of the demand from the meter indication.
- ix) For transformer-rated meters;
also:
 - (a) Current transformer rating,
e.g. CT 1000-5 A
 - (b) Voltage transformer rating,
e.g. VT 2400-120 V.
- x) For single phase transformer type meters the words "Transformer Type" in red.

If the meter is provided with accessories such as re-transmitting contacts, etc., the nameplate shall so specify and a diagram of connections shall be provided if considered necessary by the Director.

The marking shall be indelible, distinct, and visible from outside the meter with its cover in place.

Space shall be provided for affixing an inspection number.

7-5 PERFORMANCE REQUIREMENTS

7-5.1 Integrating Demand Meters.

7-5.1.1 Energy Measuring Element. The energy measuring element shall comply with the requirements of section 4 and subsection 4-5, Performance Requirements, with the exception of clause 4-5.14, Effect of Register Friction.

(a) For tests under subsection 4-5 the demand attachment shall be properly coupled to the energy measuring element, but with the demand pointer(s) or drum(s) not being driven by the mechanism.

(b) Effect of Register Friction. The register friction shall be determined by measuring the change in rotor speed with constant active power applied from the reference condition of the meter to the condition with the demand attachment decoupled from the energy measuring element.

The reference condition shall be that stated in (a) above.

When the demand attachment is decoupled, it shall be moved only enough to ensure that the coupling gears are just out of mesh.

At test point TC-2, the register friction shall not exceed 1.5%.

7-5.1.2 Maximum Demand Indicator. For the purpose of approval tests, performance requirements of block interval demand meters are based upon the performance of the demand device itself without regard to the accuracy of the watt hour meter with which it is used. Therefore corrections for any watt hour meter errors that may be involved shall be applied when computing the demand meter error.

The error of the maximum demand indication at any point between 20% and 90% of full scale shall not exceed 0.75% of full scale.

7-5.2 Thermally Lagged Demand Meters.

7-5.2.1 Reference Conditions and Test Methods. Unless stated otherwise, adjustment and tests shall be performed under the following reference conditions:

- i) the conditions stated in clause 3-5.1
- ii) unity power factor load.

All loads shall be held constant for a duration of three times the response period, and then shall be reduced to zero. The indication of the driven demand pointer after disengagement of the driving pointer shall be taken as the meter reading.

7-5.2.2 Adjustment Prior to Tests. Before commencing performance tests, the damping adjustment, if any, shall be set according to the manufacturer's instructions.

Also, the meter error shall be corrected as nearly as is practicable to zero, at both zero load and at a major scale division at or above $\frac{2}{3}$ full scale. For this calibration at a major scale division, the driving pointer shall constantly push the driven point to its final position starting from 10% of full scale or lower.

7-5.2.3 Load Performance, Unity Pf. The difference between the indicated or recorded value and the true value, at any load between 20% and 100% of full scale, shall not exceed 1.0% of full scale.

7-5.2.4 Effect of Variation of Power Factor. With a constant load of approximately 60% of full scale applied, changing the power factor from unity to 0.8 lag shall not cause a change in meter reading of more than 1.0% of full scale.

7-5.2.5 Performance with Individual Current Circuits. The meter indication shall be determined with all voltage circuits connected in parallel at rated voltage and only one current circuit carrying its maximum rated current to give a constant load.

This test shall be repeated for each current circuit. The maximum allowable difference in indication between any two tests is 1.0% of full scale value.

7-5.2.6 Effect of voltage variation. With constant active power, a variation of +10% of rated voltage shall not cause the meter indication to change by more than 1.0% of full scale. This test shall be carried out with a load such as to give approximately 60% of full scale.

7-5.2.7 Effect of Variation of Ambient Temperature. The effect of ambient temperature variation from reference temperature shall not exceed the limits given in Table 19.

TABLE 19
EFFECT OF AMBIENT TEMPERATURE VARIATION

	Ambient Temperature	Test Point % Full Scale	Maximum Difference from Indication at Reference Temp.
Meters Intended for Outdoor Service	From -7°C to +53°C	40 60 80	<u>+1.0%</u> Full Scale
	-40°C	60	<u>+3.0%</u> Full Scale
Meters Intended for Indoor Service Only and Which Have Been Designated as Suitable for a Specific Temperature Range.	Designated Temperature Range	40 60 80	(0.07% Full Scale)/°C

7-5.2.8 Effect of Radiated Heat. Radiated heat, applied as follows, shall not cause a change in the meter reading of more than 1.5% of full scale. This test shall be made at a fixed load giving approximately 80% full scale. The radiated heat shall be applied from an infra-red heat lamp No. 250R40/1 or equivalent. The lamp shall be held in any position level with or above the level of the meter for a period of not less than 30 minutes and such that the distance between the nearest points of the lamp and the meter is 600 mm. The bulb, (250 W) R40, medium base, 115-125 V shall be operated at 250 W.

7-5.2.9 Response Period. The time response characteristic shall be determined by test, at a load giving approximately 2/3 full scale. The meter readings shall be within the following limits:

- i) in one-eighth of the response period, between 10 and 30 percent of final reading
- ii) in one response period, not more than 92% of final reading.

SECTION 8 - INDUCTION TYPE LOSS METERS

CONTENTS

	Page
8-1 SCOPE	66
8-2 MECHANICAL REQUIREMENTS	66
8-3 ELECTRICAL REQUIREMENTS	66
8-4 MARKINGS	66
8-5 PERFORMANCE REQUIREMENTS	67
8-5.1 Adjustment Prior to tests	67
8-5.2 Creep	68
8-5.3 Load Performance	68
8-5.4 Performance of Individual Current Circuits	68
8-5.5 Polyphase Energization	68
8-5.6 Starting	68
8-5.7 Effect of Variation of Ambient Temperature	68
8-5.8 Effect of External Magnetic Field	68
8-5.9 Effect of Momentary Overload	69
8-5.10 Effect of Register Friction	69
8-5.11 Effect of Self-Heating	69
8-5.12 Effect of Tilt	69

SECTION 8 - INDUCTION TYPE LOSS METERS

8-1 SCOPE

The requirements of this section apply to transformer-type ampere-squared hour ($A^2.h$) meters of the induction type.

8-2 MECHANICAL REQUIREMENTS

Meters shall comply with the requirements of sub-clauses 4-2.1.1 and 4-2.2.1.

8-3 ELECTRICAL REQUIREMENTS

The requirements of clauses 4-3.3 and 4-3.4 shall apply.

8-4 MARKINGS

Every meter shall bear, as appropriate, the following information:

- i) Rated frequency
- ii) Minimum and maximum rated currents,
- iii) Number of elements
- iv) Auxilliary Supply Voltage
- v) For secondary rated meters, the disk constant in $A^2.h$ per revolution.
- vi) For primary rated meters
 - 1) Current transformer ratio
 - 2) Primary line resistance
 - 3) Primary disk constant in kW.h per revolution.

8-5 PERFORMANCE REQUIREMENTS

8-5.1 Adjustment Prior to Tests. Before commencing performance tests, the calibration shall be adjusted, as nearly as is practicable, to 100% registration. In addition, multi-element meters shall be adjusted for minimum difference in registration when each current circuit is energized separately (balance test). The calibration points, and limits of allowable deviation are set forth in Table 21.

TABLE 21

TEST POINTS FOR PRIOR ADJUSTMENTS

Test	Test Current % I _{max}	Allowable Deviation % Registration
High Load	85	0.3 from true
Light Load	40	0.5 from registration at High Load
Balance	85	0.5 from registration for any other element

8-5.2 Creep. With no current in any current coil, the disc shall not make more than one than one revolution within a ten minute interval when the compensating element is energized, at any voltage from 80% to 120% voltage.

8-5.3 Load Performance. With all circuits energized the meter shall be tested for the effect of variation of load. The error shall not exceed +2.5% at any current from 30% I_{max} to 100% I_{max} .

8-5.4 Performance of Individual Current Circuits. For multi-element meters the percentage registration shall be determined for each current circuit energized separately in turn. The maximum error at 85% I_{max} shall not exceed $\pm 2.0\%$.

8-5.5 Polyphase Energization. Polyphase meters shall be tested for accuracy at 85% I_{max} with balanced polyphase currents. The registration shall not differ from that under reference conditions by more than 0.5%.

8-5.6 Starting. The rotor shall start, and continue to rotate with 10% I_{max} flowing in all current circuits elements.

8-5.7 Effect of Variation of Ambient Temperature. The mean temperature coefficient shall be determined at 85% i_{max} and shall not exceed 0.5% per °C. This determination shall be made over a temperature range of -40°C to +53°C unless a restricted temperature range is specified in which case the determination shall be made over such range.

8-5.8 Effect of External Magnetic Field. Percentage registration at 85% I_{max} shall be determined, with and without the meter subjected to an external magnetic field as set forth in clause 4-5.12. The effect of such field shall not exceed 2.0%.

8-5.9 Effect of Momentary Overload. Percentage registration at 85% I_{max} shall be determined before and after subjecting the meter to an overload current of ten times I_{max} for 0.5 seconds. Current circuits are to be connected series assisting. Following the overload application the meter is to remain one hour with no current in any current circuit before retesting. The maximum effect of this overload application shall be 1.0%.

8-5.10 Effect of Register Friction. The change in error at 10% I_{max} , after removal of a clock type register, shall not exceed 1.0%. For cyclometer type registers, the maximum effect of friction including that a turnover through zero shall be 1.5% at 10% I_{max} .

8-5.11 Effect of Self-Heating. The effect of a sustained load equal to I_{max} for four hours shall not change the percentage registration by more than 2.0%. The reference registration for this test shall be that determined within 2 minutes of application of test current.

8-5.12 Effect of Tilt. Tilting the meter up to 3' from the vertical shall not affect the metering error at 40% I_{max} by more than 2% of true value.

For test purposes, the four positions of the tilt are specified as forward, backward, left and right. The position of true verticality shall be determined by using the plane of the stationary disc as the reference.

SECTION 9 - STATIC LOSS METERS

CONTENTS

	Page
9-1 SCOPE	71
9-2 ELECTRICAL REQUIREMENTS	71
9-3 MARKINGS	71
9-4 PERFORMANCE REQUIREMENTS	72
9-4.1 Adjustment Prior to Tests	72
9-4.2 Output at Zero Load	72
9-4.3 Load Performance	72
9-4.4 Polyphase Energization	72
9-4.5 Starting	72
9-4.6 Effect of Variation of Ambient Temperature	72
9-4.7 Effect of External Magnetic Field	73
9-4.8 Effect of Momentary Overload	73
9-4.9 Effect of Self-Heating	73
9-4.10 EMI Susceptibility	73

SECTION 9 - STATIC LOSS METERS

9-1 SCOPE

The requirements of this section apply to transformer-type, solid-state ampere-squared hour ($A^2.h$) meters.

9-2 ELECTRICAL REQUIREMENTS

The requirements of subsection 6-2 shall apply.

9-3 MARKINGS

Every meter shall bear, as appropriate, the following information:

- i) Rated frequency
- ii) Rated voltage
- iii) Minimum and maximum rated currents,
- iv) Number of elements
- v) Voltage and frequency of auxiliary supply
- vi) For secondary - rated meters, the test constant and pulse constant in $A^2.h$ per pulse
- vii) For primary rated meters
 1. Current transformer ratio
 2. Primary line resistance
 3. Pulse constant in kWh per pulse.

9-4 PERFORMANCE REQUIREMENTS

9-4.1 Adjustment Prior to Tests. If adjustments are available externally with the cover in place the calibration shall be corrected, as nearly as is practicable, to zero error before commencing tests. In addition, multi-element meters shall be adjusted to have minimum difference in registration between elements when each current circuit is energized singly and in turn.

9-4.2 Output at Zero Load. With rated voltage and zero current the registration shall not increase by more than one division of the lowest reading drum, dial or display. Meters with a pulse initiator shall not produce more than one output pulse.

9-4.3 Load Performance. With all circuits energized, the meter shall be tested for accuracy with variation in load current. The errors shall not exceed $\pm 1\%$ for any current from 5% I_{max} to I_{max} .

9-4.4 Polyphase Energization. Polyphase meters shall be tested for accuracy at 50% I_{max} with balanced polyphase currents. The registration shall not differ from that under reference conditions by more than 0.5%.

9-4.5 Starting. The meter shall start and continue to register with a current equal to 1% I_{max} in all circuits.

9-4.6 Effect of Variation of Ambient Temperature. The maximum allowable influence on accuracy due to variation of ambient temperature shall be 0.05%/°C. The determination of this coefficient shall be made at 50% I_{max} over the temperature range from -40°C to +53°C unless a restricted temperature range is specified in which case the determination shall be made over such a range.

9-4.7 Effect of External Magnetic Field. Percentage registration at 50% I_{max} shall be determined with and without the meter subjected to an external magnetic field as set forth in 4-5.12. The change in registration shall not exceed 1.5%.

9-4.8 Effect of Momentary Overload. Percentage registration shall be determined at 50% I_{max} before and after subjecting each current circuit singly and in turn to an overload current of $10 \times I_{max}$ for 0.5 seconds. Following this the meter is to remain on hour before retesting. The maximum effect of this overload application shall be 0.2%.

9-4.9 Effect of Self-Heating. The effect of a sustained load equal to I_{max} through all circuits in series for four hours shall not change the percent registration by more than 0.5%. The reference registration for this test shall be that determined within 2 minutes of application of test current.

9-4.10 EMI Susceptibility. Meters shall be subject to the EMI susceptibility tests set forth in 3-5.2.

CONTENTS

	Page
10-1 SCOPE	75
10-2 ELECTRICAL REQUIREMENTS	75
10-2.1 Auxiliary Power Supply	75
10-2.2 Preferred Current Rating	75
10-3 MARKINGS	76
10-4 PERFORMANCE REQUIREMENTS	76
10-4.1 Reference Conditions for Tests	76
10-4.2 Reactive Power Devices	77
10-4.3 Adjustment Prior to Test	77
10-4.4 Bi-Directional Transducers	77
10-4.5 Variation of Load, Unity Power Factor	77
10-4.6 (Deleted)	
10-4.7 Power Factor Response	77
10-4.8 Element Balance	77
10-4.9 Input Voltage Variation	78
10-4.10 Ambient Temperature Variation	78
10-4.11 Variation of External Circuit Resistance	78
10-4.12 Output Ripple	79
10-4.13 Output at Zero Load	79
10-4.14 External Magnetic Field	79
10-4.15 Effect of Momentary Overload	79
10-4.16 Polyphase Energization	79
10-4.17 Effect of Self Heating	80
10-4.18 EMI Susceptibility	80

SECTION 10 - TRANSDUCERS

10-1 SCOPE

These specifications apply to devices having a direct current (or voltage) output, the value of which is proportional to the ac input power, either active power (watts), reactive power (vars), or apparent power (volt-amperes).

The specifications pertain to devices which are designed for use in the secondaries of instrument transformers, i.e. for 120 V, and currents of less than 10 A. However, devices designed to meter higher voltages and/or currents may also be submitted for approval. They will be considered in the light of this and other related specifications, due discretion being used in application of various clauses.

10-2 ELECTRICAL REQUIREMENTS

10-2.1 Auxiliary Power Supply. Preferred auxiliary power supply rating is 120 V, 60 Hz.

10-2.2 Preferred Current Rating. Preferred rated input current shall be 5 A with maximum rated current of 10 A.

10-3 MARKINGS

Nameplates. In addition to the requirements of clause 3-4 nameplates shall bear the following information:

- i) Rated frequency
- ii) Rated voltage (nominal input value)
- iii) Rated current (nominal input value)
- iv) Rated input power (nominal value of input measured quantity: active, reactive, or apparent power)
- v) Maximum rated current (input) if different from rated current
- vi) Transfer constant K_a , expressed, for example as

$$K_a = W/mA$$

- vii) One of the following: *
 - 1-phase, 2-wire
 - 1-phase, 3-wire
 - 2-element
 - 2½-element wye
 - 2½-element delta
 - 3-element wye
- viii) For a transducer having a current output, the maximum external circuit resistance.
- ix) For a voltage output transducer, the minimum external circuit resistance.

*Note: Accepted symbols are: \emptyset , EL, Y, Δ .

10-4 PERFORMANCE REQUIREMENTS

10-4.1 Reference Conditions for Tests. Except where otherwise indicated the following standard test conditions shall apply:

- i) as appropriate, the conditions stated in clause 3-5.1
- ii) the output load resistance shall be
 - a) for current output transducers, 50% of maximum,
 - b) for voltage output transducers, 150% of minimum
- iii) all circuits shall have been energized for a sufficient time to obtain stable output.

10-4.2 Reactive Power Devices. For reactive energy meters where the term "power factor" appears in this subsection, the term "reactive factor" is to be substituted.

10-4.3 Adjustment Prior to Tests. If adjustments are available externally with cover in place the calibration shall be corrected as nearly as practicable to zero error, both at zero current input and at rated input before commencing tests.

10-4.4 Bi-directional Transducers. For bi-directional transducers, the requirements which follow, shall, as appropriate, apply for power flow in either direction.

10-4.5 Variation of Load, Unity Power Factor. With rated voltage the error, at any value of current from 1% I_{max} to I_{max} shall not exceed 0.5% rated output. If maximum current is not specified this requirement shall be based on rated current.

10-4.6 Variation of Load, Nominal Power Factor. Delete.

10-4.7 Power Factor Response. With nominal voltage applied and the input current set to 50% I_{max} and to I_{max} , both at 0.5 power factor, the device shall be accurate to within $\pm 0.75\%$ of reading.

*Power: active, reactive or apparent.

10-4.8 Element Balance. Polyphase devices shall be tested with with voltage elements in parallel and each current element in turn carrying rated input current at both unity and 0.5 Pf lag.

The maximum difference in output between any pair of elements shall be 0.5% of rated output.

10-4.9 Input Voltage Variation. With a constant input load applied, a variation of $\pm 10\%$ of rated input voltage shall not cause the error to deviate from that at rated voltage by more than 0.25% of rated output.

This test shall be made at approximately 50% rated output and at approximately 90% rated output. The auxiliary power supply voltage shall be varied simultaneously with the metering voltage and by the same percentage.

10-4.10 Ambient Temperature Variation. The maximum allowable influence on accuracy due to variation of ambient temperature shall be 0.035% of rated output per °C.

This influence shall be determined by comparing the registration under reference conditions with that at -40°C and at $+53^{\circ}\text{C}$ or at the temperature extremes specified on the nameplate, whichever is less.

10-4.11 Variation of External Circuit Resistance.

10-4.11.1 Transducers with current output. With a fixed input equal to rated input power, variation of the external circuit from zero up to the maximum shall not change the output by more than 0.25% rated output.

10-4.11.2 Transducers with voltage output. With a fixed input equal to rated input power variation of the external circuit resistance from minimum rated to open circuit shall not cause a change in output of more than 0.25% rated output.

10-4.12 Output Ripple. The peak to peak value of the ripple content in the output shall not exceed 1% of the rated output.

10-4.13 Output at Zero Load. The output at rated voltage and zero current shall not exceed 0.1% of rated output.

10-4.14 External Magnetic Field. The change in output shall not exceed $\pm 0.5\%$ of rated output when the device is placed in a magnetic field. The field shall be equivalent to that produced by a coil one metre in diameter having a magnetomotive force of 400 ampere-turns. The coil current shall be at the same frequency as that of the device input, but its orientation and phase shall be that which produces maximum effect. This requirement shall apply from 10% to 100% of rated input power.

10-4.15 Effect of Momentary Overload. With rated voltage applied, the input current circuits shall be energized in series at ten times the maximum rated current, or ten times rated current if no maximum is stated, for 3.0 seconds. This overload shall be applied five times with an interval of 5 minutes between successive applications. Following the fifth application, the transducer shall remain for one hour with rated voltage and no current before retesting. This overload test shall not cause a change in the output at rated input of more than 0.1% of rated output.

10-4.16 Polyphase Energization. Polyphase transducers shall be tested for accuracy with balanced polyphase voltage and currents. Test points and allowable limits of error shall be as set forth below:

Current	Power Factor	Percentage Error Limit
Any value from min. to max.	1.0	$\pm 0.75\%$
Any value from min. to max.	0.5 lag	$\pm 1.0\%$

In addition, the same tests shall be carried out with the phase sequence reversed. The same error limits shall apply. Where a definite phase sequence is specified for the transducer, the test with reversed phase sequence is not required.

10-4.17 Effect of Self-Heating. The application for four hours of rated voltage, maximum rated input current, and the input power that provides rated output shall not change the error by more than 0.3% of rated output. When a maximum rating is not stated, the rated current shall be used.

The reference error for this test shall be that determined within two minutes of application of test current.

10-4.18 EMI Susceptibility. Transducers shall be subject to the EMI susceptibility tests set forth in clause 3-5.2.

SECTION 11 - NULL BALANCING INSTRUMENTS

CONTENTS

	Page
11-1 SCOPE	82
11-2 MECHANICAL REQUIREMENTS	
11-2.1 Indicating Scale	82
11-2.2 Scale and Chart Visibility	82
11-2.3 Scale Width	82
11-2.4 Terminals	82
11-2.5 Sealing	82
11-3 ELECTRICAL REQUIREMENTS	
11-3.1 Range Selection	83
11-4 NAMEPLATES	83
11-5 PERFORMANCE REQUIREMENTS	84
11-5.1 Reference Conditions for Tests	84
11-5.2 Adjustments Prior to Tests	84
11-5.3 Test Procedure	84
11-5.4 Linearity	85
11-5.5 Dead Band	85
11-5.6 Transient Overload	86
11-5.7 Span Step-Response Time	86
11-5.8 Effect of Variation of Ambient Temperature	86
11-5.9 Effect of Interference	87
11-5.10 Effect of External Circuit Resistance	88
11-5.11 Influence of External Magnetic Field	88
11-5.12 Effect of Variation in Operating Power Supply Voltage . .	89

SECTION 11 - NULL BALANCING INSTRUMENTS

11-1 SCOPE

These specifications apply to indirect-acting electrical measuring instruments of the automatic null-balancing type used for the measurement of demand in watts, vars, or volt-amperes.

They also apply to auxiliary devices which may be included within the instrument case.

11-2 MECHANICAL REQUIREMENTS

11-2.1 Indicating Scale. For each recorded quantity there shall be an indicating pointer or digital display. The scale for the pointer shall have graduations similar to those on the chart.

11-2.2 Scale Chart and Visibility. The instrument shall be so designed that the scale and chart may be easily read with the cover closed. On strip-chart instruments a portion of the most recent record shall be visible with the cover closed.

11-2.3 Scale Width. Minimum scale width shall be 100 mm.

11-2.4 Terminals. The terminals shall be legibly marked and information shall be provided to identify the proper connections.

11-2.5 Sealing. Construction shall be such that access to the working parts may be prevented by means of a door lock or other suitable device.

11-3.1 Range Selection. If a recorder has provision for changing the range by means of interchangeable range modules, each module shall be clearly identified. Provision shall be made for sealing so that range changing cannot be accomplished without breaking the seal.

11-3.2 Dielectric Properties. Delete

11-4 NAMEPLATES

In addition to the requirements of clause 3-4 every instrument shall have the following details indelibly and distinctly marked on one or more nameplates visible from the front with the cover closed:

- i) Voltage and frequency of power supply
- ii) Designation of the unit of measurement and multiplier if other than 1.

The following information shall be legibly marked on the instrument and accessible from the front but need not be visible with cover closed:

- i) Chart identification number
- ii) Maximum external resistance
- iii) Response-time designation: Span step-response time for single point instruments or time per point for multiple point instruments.
- iv) Range of measured quantity.

11-5 PERFORMANCE REQUIREMENTS

11-5.1 Reference Conditions for Tests. Except when otherwise indicated, the following standard test conditions shall apply:

- i) The operating power supply voltage and frequency shall be the rated value $\pm 0.5\%$.
- ii) External test circuits shall be isolated from ground, and from the operating power supply. There shall be no potential applied between the test circuit and the instrument case.
- iii) The chart ink recommended by the manufacturer shall be used.
- iv) A resistance equal to 50% of the maximum external resistance shall be connected between the test source and the recorder input terminals.

11-5.2 Adjustment Prior to Tests.

11-5.2.1 Before commencing performance tests it shall be established that the chart drive, inking and pen or printing mechanism are in proper operating condition.

11-5.2.2 The instrument shall be set up and all adjustments set in accordance with the manufacturer's instructions to give minimum error at zero and at a calibration point near $2/3$ full scale.

11-5.3 Test Procedure.

11-5.3.1 Copper wire shall be used for connecting the test source and the reference standard to the instrument under test.

11-5.3.2 The test source shall be adjusted to bring the indication of the instrument under test to a cardinal scale point. This is to be done approaching the balance point from each direction. For a recorder, the pen mark on the chart shall be used as the instrument reading; for an indicating meter, the indicating scale shall be used.

11-5.4 Linearity. When the instrument is tested for accuracy under standard reference conditions, the error, at any cardinal scale point, shall not exceed 0.5% of full scale.

11-5.5 Dead Band.

11-5.5.1 Maximum dead band shall be 0.2% of full scale.

11-5.5.2 The method of determining the dead band shall be as follows:

- (a) Connect the reference equipment to the instrument under test and set it at a value corresponding approximately to midspan of the instrument.
- (b) Increase the source voltage by an amount corresponding to approximately 0.5% of span.
- (c) Slowly decrease the source voltage until the instrument reading is exactly the same as the original in step (a). Observe the reading of the reference meter.
- (d) Decrease the source voltage by an amount corresponding to approximately 0.5% of span.

- (e) Slowly increase the source voltage until the instrument reading is exactly the same as the original in step (a). Observe the reading of the reference meter.
- (f) The difference between the readings obtained in (c) and in (e), expressed in percent of full scale, is the dead band.

11-5.6 Transient Overload

11-5.6.1 Method of Test. The instrument shall be allowed to balance near one end of the span. An abrupt change in measured signal equivalent to approximately 90 percent of span shall be applied to the instrument. The amount of overshoot beyond the point of final balance expressed in percent of span is the transient overshoot. Test shall be repeated for opposite direction of balancing action.

11-5.6.2 Permissible Value. Maximum permissible transient overshoot shall be 0.2 percent of span.

11-5.7 Span Step-Response Time. An abrupt change in the measured quantity equivalent to 99% of span shall be applied and the instrument allowed to balance. The test shall be repeated for opposite direction of balancing action. The measured span step-response time shall not differ from the manufacturer's stated value by more than 10%.

11-5.8 Effect of Variation of Ambient Temperature. The maximum allowable influence due to variations in ambient temperature shall not affect the performance of the device by more than the limits given in the following table.

This influence shall be determined by comparing the performance under reference conditions with that at -40°C and $+53^{\circ}\text{C}$ or at the temperature extremes specified on the nameplate, whichever is less.

<u>Temperature Effect On</u>	<u>Permissible Limits</u>
Error	0.02% of span per °C
Dead Band	0.01% of span per °C
Span step-response time	10% of response time at 23°C
Transient overshoot	0.01% of span per °C

11-5.9 Effect of Interference. The maximum allowable influence due to interference, as determined by the tests detailed below, shall be as follows:

Effect on	Max. Allowable Influence in % of span, due to	
	Common Mode Interference	Normal Mode Interference
Error	0.1	0.2
Dead Band	0.1	0.2

11-5.9.1 Common Mode Interference - method of test (Refer to Fig. 3). With the instrument balanced at approximately, mid-span, common mode interference shall be artificially introduced by applying voltage of operating power supply frequency between each measuring circuit terminal and the case. This voltage shall be adjustable in magnitude and shall be applied through a blocking capacitor to prevent grounding the input terminals. Means shall be provided for continuously shifting the phase angle of the applied voltage. The rms magnitude shall be measured by a voltmeter connected between the instrument case and the measuring circuit terminal.

The rms magnitude of the common mode interference voltage shall be adjusted to be equal to the span of the instrument, and the phase angle varied through 360 degrees.

11-5.9.2 Normal Mode Interference - method of test (Refer to Fig. 4). With the instrument balanced at approximately mid-span, normal mode interference shall be artificially introduced by applying a voltage of operating power supply frequency between the measuring circuit terminals. This voltage shall be adjustable in magnitude and isolated from the operating power supply and ground by a suitable transformer. A blocking capacitor shall be used to prevent loading the dc measured quantity. The r.m.s. magnitude of this voltage shall be measured by a voltmeter connected to the input terminal. Means shall be provided for continuously shifting the phase angle of the applied voltage.

The r.m.s. magnitude of the normal mode interference shall be adjusted to be 20% of the span and the phase angle shall be varied through 360 degrees.

11-5.10 Effect of External Circuit Resistance. The effect of inserting maximum external resistance shall not cause a change (from reference conditions) exceeding the following limits:

Error	0.15% of span
Dead Band	0.15% of span
Span Step-Response Time	10%
Transient Overshoot	Negligible

11-5.11 Influence of External Magnetic Field. The instrument shall be placed in a magnetic field equivalent to that produced by a coil one metre in diameter having a magnetomotive force of 400 ampere-turns.

The frequency of the coil current shall be the same as that of the instrument operating power supply. The phase of the coil current and the orientation of the coil shall be adjusted to produce maximum effect. The maximum allowable influence shall be as follows:

- i) On instrument accuracy: $\pm 0.6\%$ of span
- ii) On dead band: $\pm 0.25\%$ of span

11-5.12 Effect of Variation in Operating Power Supply Voltage. A variation in the operating supply voltage of 10% above or below the reference value shall not affect the performance by more than the limits given below:

<u>Effect On</u>	<u>Permissible Limit</u>
Error	0.2% of span
Dead Band	0.1% of span
Span Step-Response Time	10%
Transient Overshoot	0.2% of span

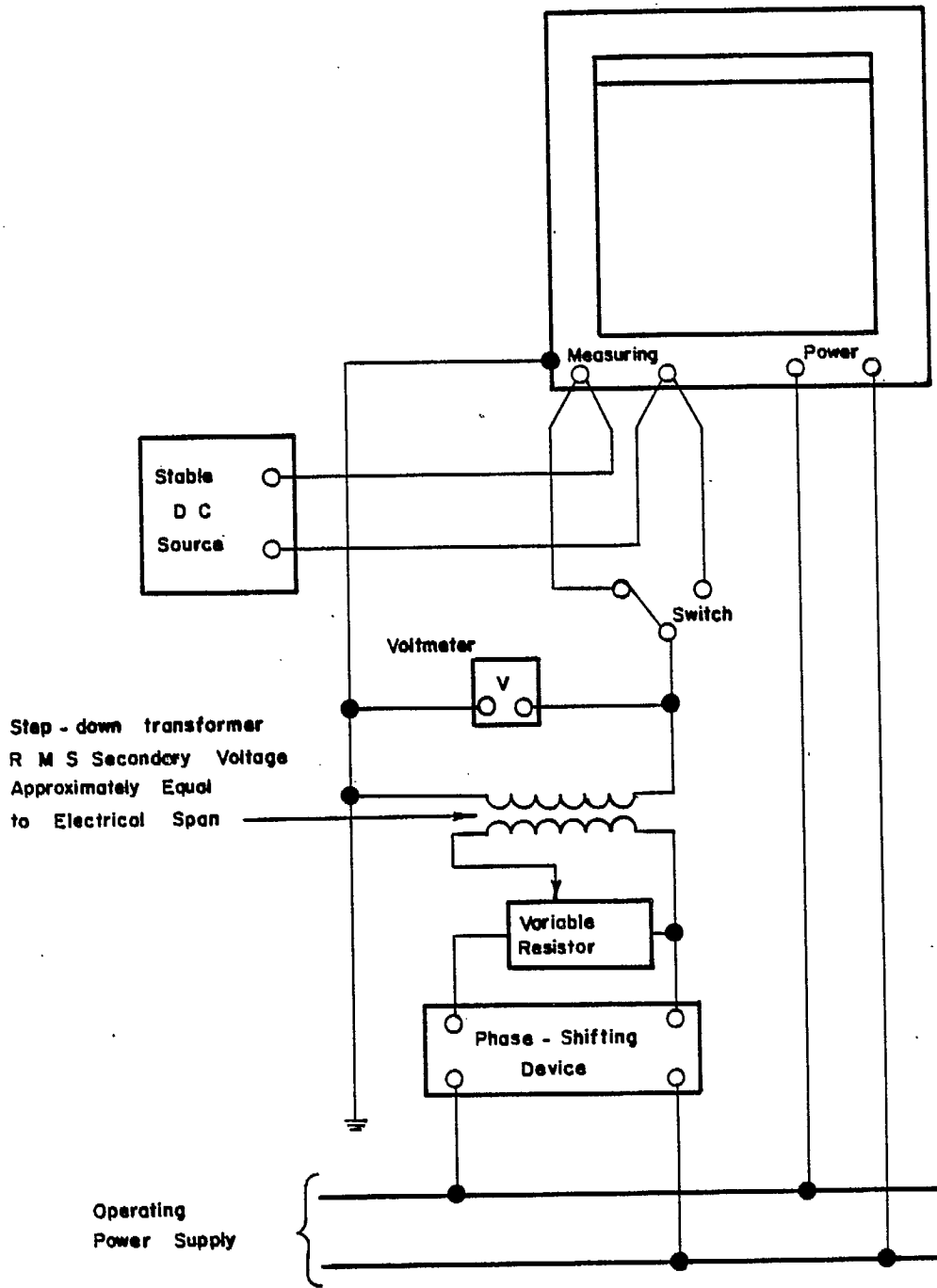

TEST FOR COMMON MODE INTERFERENCE INFLUENCE
FIGURE 3

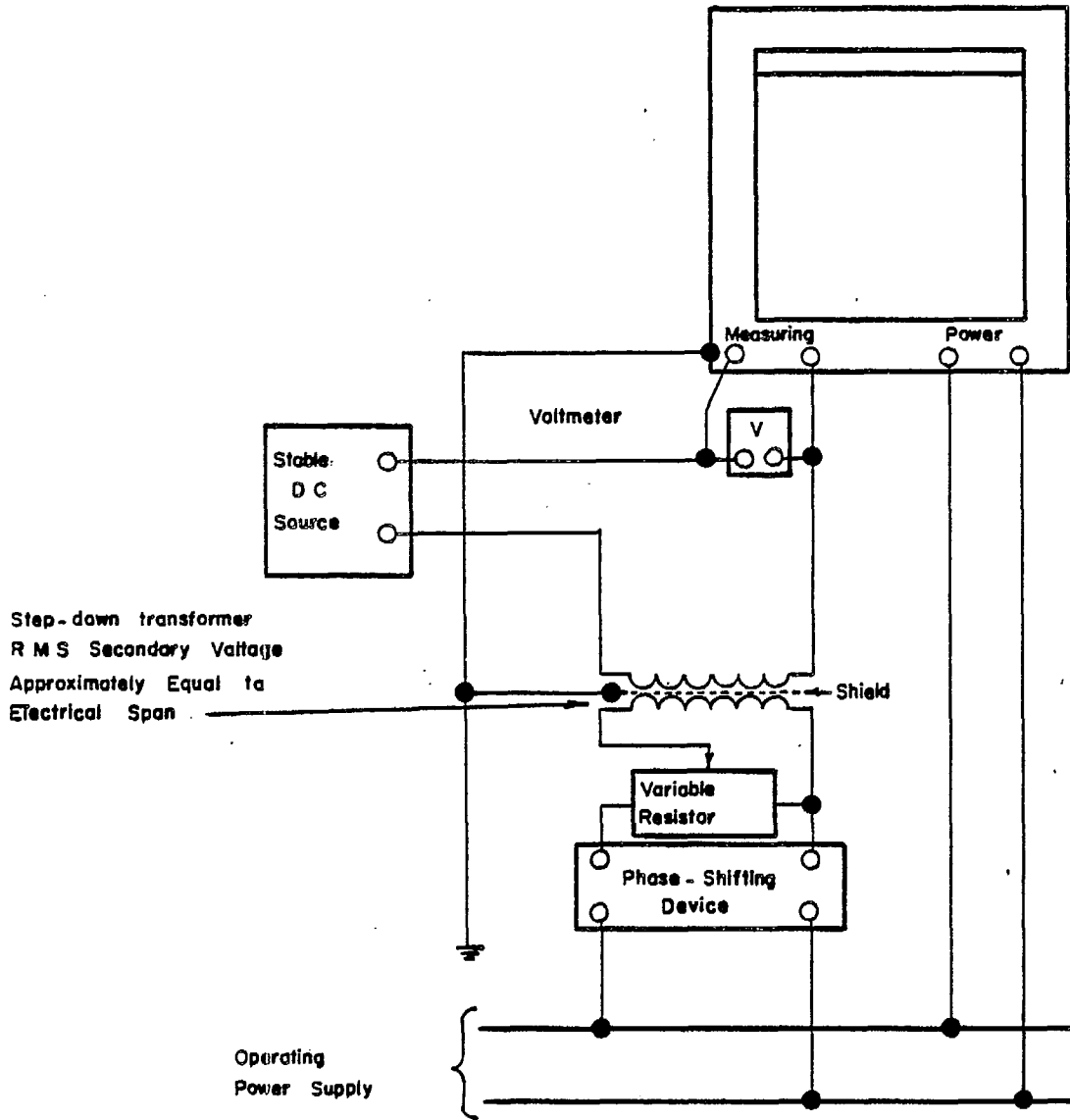

TEST FOR NORMAL MODE INTERFERENCE INFLUENCE
FIGURE 4

SECTION 12 - PULSE DEVICES

CONTENTS

	Page
12-1 SCOPE	93
12-2 MECHANICAL REQUIREMENTS	93
12-2.1 Reverse detent	93
12-2.2 Mechanical Load	93
12-3 ELECTRICAL REQUIREMENTS	93
12-3.1 Insulation	93
12-3.2 Pulse Rate for Demand Measurement	93
12-4 MARKINGS	93
12-4.1 Pulse Initiators	94
12-4.2 Relays and Pulse Amplifiers	94
12-4.3 Totalizers	94
12-5 PERFORMANCE REQUIREMENTS	95
12-5.1 Test Conditions	95
12-5.2 Performance Tests	95
12-5.3 Effect of Ambient Temperature	95
12-5.4 EMI Susceptibility	95
12-5.5 Effect of External Magnetic Field	95

SECTION 12 - PULSE DEVICES

12-1 SCOPE

The requirements of this section shall apply to pulse initiators, relays and totalizers.

12-2 MECHANICAL REQUIREMENTS

12-2.1 Reverse Detent. No pulse initiator shall be fitted to an induction-type meter unless the meter or the initiator is furnished with a reverse detent.

12-2.2 Mechanical Load. The mechanical load imposed on a meter by a pulse initiator shall be within the adjustment range of the meter. This load shall be as nearly constant as practical through-out the entire cycle of operation of the pulse initiator.

12-3 ELECTRICAL REQUIREMENTS

12-3.1 Insulation. The requirements of clause 3-3.4 shall apply.

12-3.2 Pulse Rate for Demand Measurement. A pulse initiator which generates pulses intended for use in calculating demand, shall have a minimum pulse rate of 25 pulses per minute when its host meter is operating at 50% of its maximum load under normal operating conditions. Approval notices for meters fitted with pulse initiators which do not meet this requirement shall explicitly state that the pulses from the meter are not to be used for calculating demand for revenue purposes.

12-4 MARKINGS

Devices covered by this section shall be exempt from the requirements of clause 3-4.1. The information which shall be marked (if applicable) is set out hereunder.

12-4.1 Pulse Initiators (Information may be on initiator or host meter)

- i) Type identification
- ii) Pulse initiator output constant K_p

12-4.2 Relays and Pulse Amplifiers

- i) Manufacturer's name or trademark
- ii) Type identification
- iii) Type of input (2 or 3 wire)
- iv) Type of output (2 or 3 wire)
- v) Voltage and frequency of auxiliary supply (if applicable)
- vi) Rated or maximum voltage and frequency (pulses per unit time) of input pulses
- vii) Minimum pulse width if critical to operation of the device
- viii) Connection diagram

12-4.3 Totalizers

- i) Manufacturer's name or trademark
- ii) Type identification
- iii) Input to output pulse ratio, (prescalar unit)
- iv) Number of additive and subtractive elements.
If both are present, each shall be clearly identified.
- v) Type of input (2 wire or 3 wire)
- vi) Type of output (2 wire or 3 wire)
- vii) Voltage and frequency of the auxiliary power supply
- viii) Rated or maximum voltage and frequency (pulses per unit time) of the input pulses
- ix) Connection diagram.

12-5 PERFORMANCE REQUIREMENTS

12-5.1 Test Conditions. The device shall be mounted on a support free from vibration. All tests shall be made at $23^{\circ}\text{C} \pm 2^{\circ}\text{C}$, and at rated voltage and frequency, unless otherwise specified.

The device shall be connected so as to initiate or receive pulses, or both, and the pulse output shall be connected to a counter for the purpose of recording the total pulses transmitted. The counter shall be such that its connection to the device under test shall have no effect on the device.

12-5.2 Performance Test. The device shall not gain nor lose more than 0.05% of its pulses when operated for at least one hour at maximum pulse capacity at 85%, 100% and 110% of nameplate voltage. If the device has both an input voltage and supply voltage, both shall be varied simultaneously and by the same percentage.

12-5.3 Effect of Ambient Temperature. The device shall not gain or lose more than 0.05% of its pulses when operated for at least one hour at maximum pulse capacity over a temperature range from -40°C to $+53^{\circ}\text{C}$ or at the temperature extremes specified on the nameplate, whichever is less.

12-5.4 EMI Susceptibility. The requirements of clause 3-5.2 shall apply.

12-5.5 Effect of External Magnetic Field. The device shall be capable of operating, without degradation of performance in an external 60 Hz alternating field. This field shall be equivalent to that produced by a coil one metre in diameter having a magnetomotive force of 400 ampere-turns.

SECTION 13 - PROGRAMMABLE DEVICES AND PULSE RECORDERS

CONTENTS

	Page
13-1 SCOPE	97
13-2 MECHANICAL REQUIREMENTS	97
13-2.1 Register	97
13-2.2 Sealing	97
13-3 ELECTRICAL REQUIREMENTS	97
13-3.1 Insulation	97
13-3.2 Timing Reference	97
13-3.3 Battery Carry-Over	97
13-4 MARKINGS	98
13-5 PERFORMANCE REQUIREMENTS	98
13-5.1 Accuracy	98
13-5.2 Effect of External Magnetic Field	99
13-5.3 EMI Susceptibility	99
13-5.4 Device Integral with Meter	99
13-6 PROGRAM REQUIREMENTS	99
13-6.1 Demand Interval	99
13-6.2 Totalisation	99
13-6.3 Security	99

SECTION 13 - PROGRAMMABLE DEVICES AND PULSE RECORDERS

13-1 SCOPE

These requirements apply to solid state programmable or programmed devices which accept pulses from meters and process this information. They apply to pulse recorders but not to devices covered by any other section.

13-2 MECHANICAL REQUIREMENTS

13-2.1 Register. If the device is fitted with one or more mechanical registers the requirements of clause 3-2.7 shall apply.

13-2.2 Sealing. Devices shall be provided with facilities for sealing to prevent unauthorized access to the working parts or to any means of altering the program.

13-3.1 Insulation. The requirements of clause 3-3.4 shall apply.

13-3.2 Timing Reference.

13-3.2.1 Main Time Base. The main time base shall be synchronized with the line frequency and shall be capable of operating with a variation of $\pm 10\%$ of the nominal supply voltage.

13-3.3 Battery Carry-Over Devices storing billing data or programming information which could be lost in the event of a power outage shall be fitted with a battery carry-over feature to prevent such loss over the temperature range specified for the device over the following minimum intervals.

a) For 24 hours for a device which automatically recharges the standby battery upon the restoration of power following an electrical outage.

b) For 7 days for all other devices.

13-4 MARKINGS

As appropriate, the following information shall be clearly marked on the nameplate or other suitable location:

- i) Manufacturer's name or mark
- ii) Manufacturer's serial number
- iii) Manufacturer's type designation
- iv) Demand interval
- v) Up-date interval, and for each channel, input identification, pulse constant and multiplier or prescalar unit
- vi) rated voltage and frequency of auxiliary power supply
- vii) rated or maximum voltage and frequency (pulses per unit time) of the input pulses
- viii) connection diagram.

Note 1: Where the device is a register included as an integral part of a meter, and not wholly detachable, the above information may be shown on the meter nameplate.

Note 2: iv: The demand interval shall be marked on any device which measures or calculates a demand quantity over a specific interval. If no such measurements or calculations are made, then the demand interval is not applicable to the markings required on the nameplate.

Note 3: v: If a device simply receives pulses, temporarily storing them, and then retransmits them, or a fraction or multiple thereof, then the pulse constant need not be marked on the nameplate since the pulses could come from any source and be sent to any other receiving device.

13-5 PERFORMANCE REQUIREMENTS

13-5.1 Accuracy.

13-5.1.1 Pulse Count Accuracy. Pulses shall be supplied to all applicable channels simultaneously at maximum rated pulse rate for a period of not less than two demand intervals. Maximum allowable pulse count deviation shall be $\pm 0.05\%$. The pulse counter used for this test shall be such that its connection to the device under test shall have no effect on the device.

This requirement shall apply over a range of input supply voltage variation of $\pm 10\%$ of rated nameplate value.

The device shall not gain or lose more than 0.05% of its pulses when operated for at least one hour at maximum pulse capacity over a temperature range from -40°C to $+53^{\circ}\text{C}$ or at the temperature extremes specified on the nameplate, whichever is less.

13-5.1.2 **Calculated Quantities.** The computational error introduced by devices calculating the magnitude of quantities derived from measured or input values shall not exceed +0.1% of the output reading.

13-5.2 **Effect of External Magnetic Field.** The device shall be capable of operating without degradation of performance in an externally generated 60 Hz field. This field shall be equivalent to that produced by a coil one metre in diameter and having a magnetomotive force of 400 ampere-turns.

13-5.3 **EMI Susceptibility.** The requirements of clause 3-5.2 shall apply.

13-5.4 **Device Integral with Meter.** Where a programmable device is integral with an induction type meter, the meter shall withstand all tests set forth in clauses 4-3.4, 4-5.13 and 4-5.17 without degradation of performance of the device.

13-6 PROGRAM REQUIREMENTS

13-6.1 **Demand Interval.** The demand interval shall be not less than fifteen minutes.

13-6.2 **Totalization.** The totalization of volt-amperes or volt ampere hours of two or more feeder lines shall be by vector addition. The summation of the volt-amperes of the individual phases of a single line may be calculated by either vector or arithmetic addition.

13-6.3 **Security.** The basic operating constants, Kp, Kh, demand period etc. used in calculating meter quantities (e.g. kW.h) shall be stored within the device in such a manner that they cannot be changed without breaking the meter seal. This means these constants shall not be alterable by a meter reader, communications signal, power outage or any other technique which does not require breaking the meter seal.

SECTION 14 - INSTRUMENT TRANSFORMERS

CONTENTS

	Page
14-1 SCOPE	101
14-2 DEFINITIONS	101
14-3 GENERAL	107
14-3.1 Scope	107
14-3.2 Electrical Requirements	107
14-3.3 Markings	107
14-3.4 Preferred Ratings	107
14-4 CURRENT TRANSFORMERS	108
14-4.1 Scope	108
14-4.2 Accuracy Requirements	108
14-5 VOLTAGE TRANSFORMERS	110
14-5.1 Scope	110
14-5.2 Accuracy	110
14-6 CAPACITOR VOLTAGE TRANSFORMERS	112
14-6.1 Scope	112
14-6.2 Markings	112
14-6.3 Accuracy	112
14-7 PHASING TRANSFORMERS	113
14-7.1 Scope	113
14-7.2 Accuracy	113

14.1 - SCOPE

This specification establishes acceptable performance criteria for new types of instrument transformers intended for use in revenue metering.

14.2 - DEFINITIONS

14-2.1. Accuracy Class. A designation assigned to an instrument transformer the errors of which remain within specified limits under prescribed conditions of use.

14-2.2. Accuracy Rating. The accuracy class followed by a standard burden for which the accuracy class applies.

14-2.3. Accuracy Rating Voltage. The normal operating voltage of a voltage transformer upon which the accuracy characteristics are based.

14-2.4. Burden. That property of the circuit connected to the secondary winding that determines the active and reactive power at the secondary terminals. The burden is expressed either as total ohms impedance with the effective resistance and reactance components, or as the total volt-amperes and power factor at the specified value of current or voltage, and frequency.

14.2.5. Capacitor Voltage Transformer. A voltage transformer comprising a capacitor divider unit and an electromagnetic unit so designed and interconnected that the secondary voltage of the electromagnetic unit is substantially proportional to and in phase with the primary voltage applied to the capacitor divider unit.

14-2.6. Continuous Current Rating Factor (RF). The specified factor by which the rated current of a current transformer can be multiplied to obtain the maximum current that can be carried continuously without exceeding either the limiting temperature rise from 30°C ambient temperature, or the rated accuracy class limitation.

14-2.7. Current Transformer. An instrument transformer intended to have its primary winding connected in series with the conductor carrying the current to be measured or controlled.

14-2.8. Dielectric Tests (Voltage-Withstand Tests). Tests which consist of the application of a voltage higher than the rated voltage for a specified time for the purpose of determining the adequacy against breakdown of insulating materials and spacing under normal conditions.

14-2.9. Double-Primary Current Transformer. A current transformer equipped with two primary windings suitable for series or parallel connection and common to all secondary coils and magnetic circuits.

14-2.10. Double-Ratio Current Transformer. A multi-ratio current transformer which has two ratios which are in the ratio of two to one.

14-2.11. Double-Secondary Current Transformer. One which has two secondary coils each on a separate magnetic circuit with both magnetic circuits excited by the same primary winding or windings. The secondary coils may be tapped or untapped.

14-2.12. Double-Secondary Voltage Transformer. One which has two secondary windings on the same magnetic circuit insulated from each other and the primary. Either or both of the secondary windings may be used for measurement or control.

14-2.13. Dual-Ratio Current Transformer. A multi-ratio current transformer having two ratios which are not necessarily in the relation of two to one.

14-2.14. Highest Rated Burden of a Voltage Transformer. The assigned rated burden that has the highest nominal apparent power (V A).

14-2.15. Highest Voltage for Equipment. The highest continuous rms steady-state voltage for which the equipment insulation is designed.

14-2.16. Instrument Transformer. A transformer which is intended to reproduce in its secondary circuit, in a definite and known proportion, the current or voltage of its primary circuit with the phase relations substantially preserved.

14-2.17. Marked Ratio. The ratio of the rated primary value to the rated secondary value as stated on the nameplate.

14-2.18. Metering Outfit. A combination of voltage and current transformers in a single tank or assembly.

14-2.19. Multi-Ratio Current Transformer. One from which more than one ratio can be obtained by the use of taps or series-multiple connection.

14-2.20. Multiple Secondary Current Transformer. One which has three or more secondary coils each on a separate magnetic circuit with all magnetic circuits excited by the same primary winding.

14-2.21. Per Cent Ratio Error of an Instrument Transformer. The difference between the ratio correction factor and unity expressed in per cent.

14-2.22. Phase Angle Correction Factor (PACF). The ratio of the true power factor to the measured power factor. It is a function of both the phase angle of the instrument transformer and the power factor of the primary circuit being measured.

NOTE: The phase angle correction factor is the factor which corrects for the phase displacement of the current or voltage or both, due to the instrument transformer phase angle. The measured watts or watt hours in the secondary circuits of instrument transformers must be multiplied by the phase angle correction factor and the true ratio to obtain the true primary watts or watt hours.

14-2.23. Phase Angle of an Instrument Transformer. The phase displacement, between the primary and secondary values.

NOTE: The phase angle of a current transformer is designated by the Greek letter beta (β) and is positive when the current leaving the identified secondary terminal leads the current entering the identified primary terminal. The phase angle of a voltage transformer is designated by the Greek letter gamma (γ) and is positive when the secondary voltage from the identified to the unidentified terminal leads the corresponding primary voltage.

14-2.24. Phase Defect (PD) of a Phasing Transformer. The angular departure of the actual secondary voltage from the theoretically correct position.

14-2.25. Phase Shifting Transformer (Phasing Transformer). An instrument transformer that is an assembly of two or more auto-transformers used as auxiliary instrument transformers, intended to be connected across the phases of a polyphase circuit so as to provide voltages in the proper phase relations for energizing var meters, var hour meters, or other measurement equipment.

14-2.26. Rated Primary Current (of a Current Transformer). The current selected for the basis of performance specifications.

14-2.27. Rated Primary Voltage (of a Voltage Transformer). The voltage selected for the basis of performance specifications.

14-2.28. Rated Secondary Current. The rated primary current divided by the marked ratio.

14-2.29. Rated Secondary Voltage. The rated primary voltage divided by the marked ratio.

14-2.30. Rated Voltage Factor (RVF) of a Voltage Transformer. The multiplying factor to be applied to the primary accuracy rating voltage to determine the maximum voltage at which a transformer complies with the relevant thermal requirements for a specified time, and at which a protective voltage transformer complies with the relevant protective accuracy classes.

14-2.31. Ratio Correction Factor (RCF). The ratio of the true ratio to the marked ratio. The primary current or voltage is equal to the secondary current or voltage multiplied by the marked ratio times the ratio correction factor.

14-2.32. Ratio Correction Factor of a Phasing Transformer. The ratio of the theoretically correct shifted output voltage to the actual shifted output voltage.

14-2.33. Thermal Burden Rating (of a Voltage Transformer). The volt-ampere output that the transformer will supply continuously at accuracy rating voltage without exceeding the specified temperature limits.

14-2.34. Three-Wire Current Transformer. One which has two separate primary windings each completely insulated for the rated insulation level of the transformer. This type of current transformer is for use on a three-wire, single-phase service.

NOTE: These may have two primary windings, one secondary winding and one core assembled as a single unit; or have two primary windings, two secondary windings and two cores assembled as separate units and mounted on one base with the secondaries connected permanently in parallel to a single terminal block. The secondary current in both cases is proportional to the phasor sum of the primary currents.

14-2.35. Transformer Correction Factor (TCF). The ratio of true watts or watt hours to the measured watts or watt hours, divided by the marked ratio.

NOTE: The transformer correction factor is the ratio correction factor multiplied by the phase angle correction factor for a specified primary circuit power factor.

14-2.36. True Ratio. The ratio of the root-mean-square (rms) primary value to the rms secondary value under specified conditions, with sinusoidal current or voltage in the primary winding.

14-2.37. Type. The manufacturer's designation for transformers having different nominal currents or voltages, but which are similar in:

- a) Measurement characteristics
- b) Model and construction

14-2.38. Voltage Classification. The level of power frequency voltage which identifies the system of insulation levels and associated tests applicable to the transformer.

14-2.39. Voltage Transformer. An instrument transformer intended to have its primary winding connected in shunt with a power supply circuit, the voltage of which is to be measured or controlled.

14-3 GENERAL

14-3.1 Scope

This subsection contains requirements common to both current transformers and voltage transformers.

14-3.2 Electrical Requirements

14-3.2.1 Dielectric Tests. Transformers shall comply with the requirements of clause 7.9 of CSA Standard C13.

14-3.2.2 Temperature Rise. Transformers shall comply with the requirements of clause 3.8 of CSA Standard C13.

14-3.3 Markings

14-3.3.1 Terminals. The terminals markings shall identify:

- (a) the primary and secondary windings,
- (b) the winding sections, if any,
- (c) the relative polarities of windings and winding sections,
- (d) the intermediate tappings, if any.

Terminal markings shall be as set out in clause 3.10 of CSA Standard C13-82.

14-3.3.2 Nameplate. Nameplates shall include, as a minimum, where applicable, the following:

- (a) Manufacturer's name or trademark.
- (b) Manufacturer's type
- (c) Manufacturer's serial number
- (d) Rated frequency (e) Rated primary and secondary current(s)/(voltage(s))
- (f) Voltage classification (may be omitted for bushing type)
- (g) Continuous current rating factor (RF).
- (h) Metering accuracy rating.
- (i) Departmental Approval number.

14-3.3.2.1 Nameplate Positioning. The nameplate shall be attached so as to be clearly visible or easily accessible. If the transformer is contained within another device such as a power transformer, metering outfit, or circuit breaker, the nameplate shall be mounted on the exterior of such device in such a manner as to be readily visible.

14-3.4 Preferred Ratings.

Preferred voltage and current ratings shall be those set out in Tables 9, 13 and 14 of CSA Standard C13.

14-4 CURRENT TRANSFORMERS

14-4.1 Scope. This subsection sets out the accuracy requirements for current transformers.

14-4.2 Accuracy Requirements.

14-4.2.1 Basis for Metering Accuracy Classes. Accuracy classes for metering are based on the requirement that the transformer correction factor (TCF) shall be within specified limits for the following conditions:

One hundred per cent of rated primary current and current corresponding to the RF, if it is greater than one, at any value of power factor (lagging) of metered load from 0.6 to 1.0 with a specified standard burden. At 10 per cent of rated primary current the permissible error is twice as great at 100 per cent current. The accuracy at any lower standard burden shall be at least equal to that at the specified burden.

14-4.2.2 Standard Burdens. Standards burdens for current transformers based on rated secondary current of 5A are given in Table 21.

TABLE 21

Burden Designation	Impedance (ohms)	Power Factor	Volt-Amperes (at 5 A)
B-0.1	0.1	0.9	2.5
B-0.2	0.2	0.9	5.0
B-0.5	0.5	0.9	12.5
B-0.9	0.9	0.9	22.5
B-1.8	1.8	0.9	45.0
B-1.0	1.0	0.5	25.0
B-2.0	2.0	0.5	50.0

Note: For current transformers not having a 5 A secondary current rating the burdens shall be derived from the burdens specified in Table 21, in inverse ratio of the squares of the rated currents. For example; burdens for a 1 A secondary rating shall be 25 times (5^2) the values for a 5 A secondary rating.

14-4.2.3 Standard Accuracy Classes. Current transformers shall be of accuracy class 0.3 or 0.6. Limiting values of RCF and phase angle for these accuracy classes are shown in Figure 5.

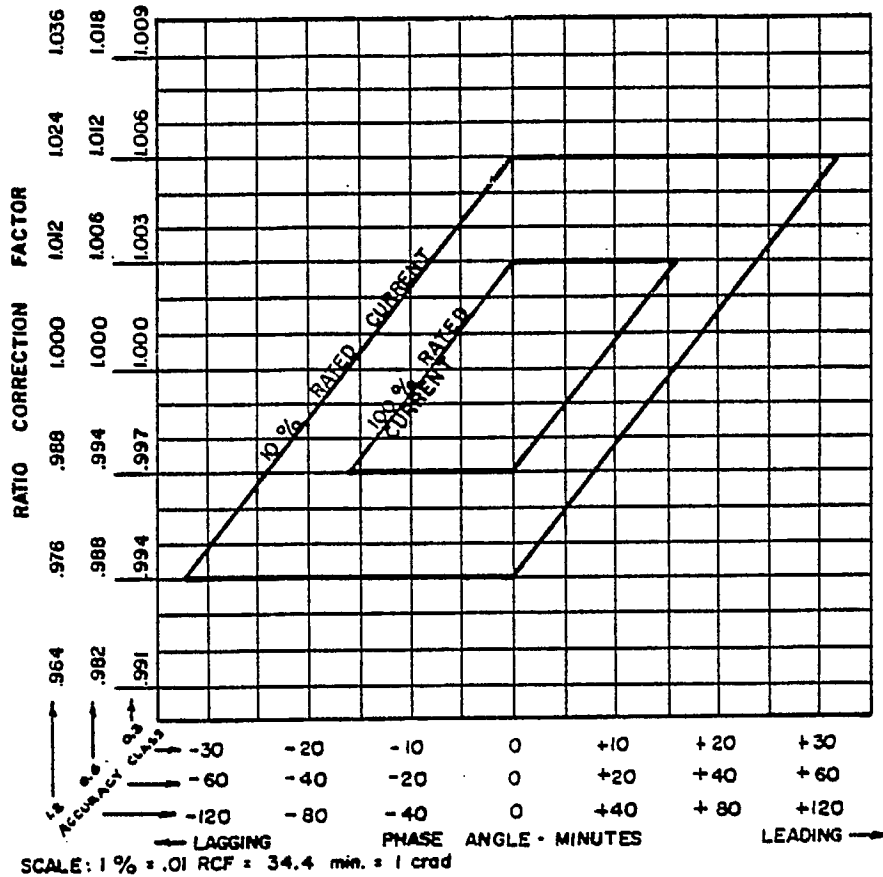

- NOTES: 1. Only current transformers of accuracy classes 0.3 and 0.6 may be approved for revenue purposes.
 2. The accuracy requirements for 100 per cent rated current also apply at the continuous current rating of the transformer.

FIGURE 5
LIMITS OF ACCURACY CLASSES

14-4.2.4 Assignment of Accuracy Rating. A current transformer shall be given an accuracy rating for each standard burden up to the maximum for which it is designed. For example, a current transformer with accuracy 0.3B-0.2, 0.3B-0.5, 0.6B-0.9, 0.6B-1.0 and 0.6B-1.8 would be marked 0.3B0.5 and 0.6B-1.8. The nameplate marking shall be such as to specify clearly the accuracy performance which the user may expect.

14-4.2.5 Multi-Ratio Transformers. For multi-ratio transformers, if only one accuracy rating is assigned it shall apply to all ratios.

14-4.2.6 Accuracy Tests. Before commencing accuracy tests each current transformer shall be demagnetized. Either of the two methods described in clause 7.3 of CSA C13 may be used.

14-5 VOLTAGE TRANSFORMERS

14-5.1 Scope. This subsection sets out the accuracy requirements for voltage transformers. Note that capacitor voltage transformers and phasing transformers are dealt with in subsections 14-6 and 14-7 respectively.

14-5.2 Accuracy.

14-5.2.1 Basis for Metering Accuracy Classes. Accuracy classes for metering are based on the requirement that the transformer correction factor (TCF) shall be within specified limits when the power factor (lagging) of the metered load has any value from 0.6 to 1.0. The limits apply from zero burden to the rated burden, at any voltage between 90 and 110 per cent of the transformer accuracy-rating voltage.

14-5.2.2 Standard Burdens. Standard metering burdens for voltage transformers based on secondary voltage of 120 or 69.3 are set out in Table 22.

TABLE 22

Burden Designation	Volt-amperes	Power Factor
W	12.5	0.10
X	25	0.70
Y	75	0.85
Z	200	0.85
ZZ	400	0.85

14-5.2.3 Standard Accuracy Classes. Voltage transformers may be of accuracy class 0.3, 0.6 or 1.2. Limiting values of RCF and phase angle for these accuracy classes are shown in Figure 6.

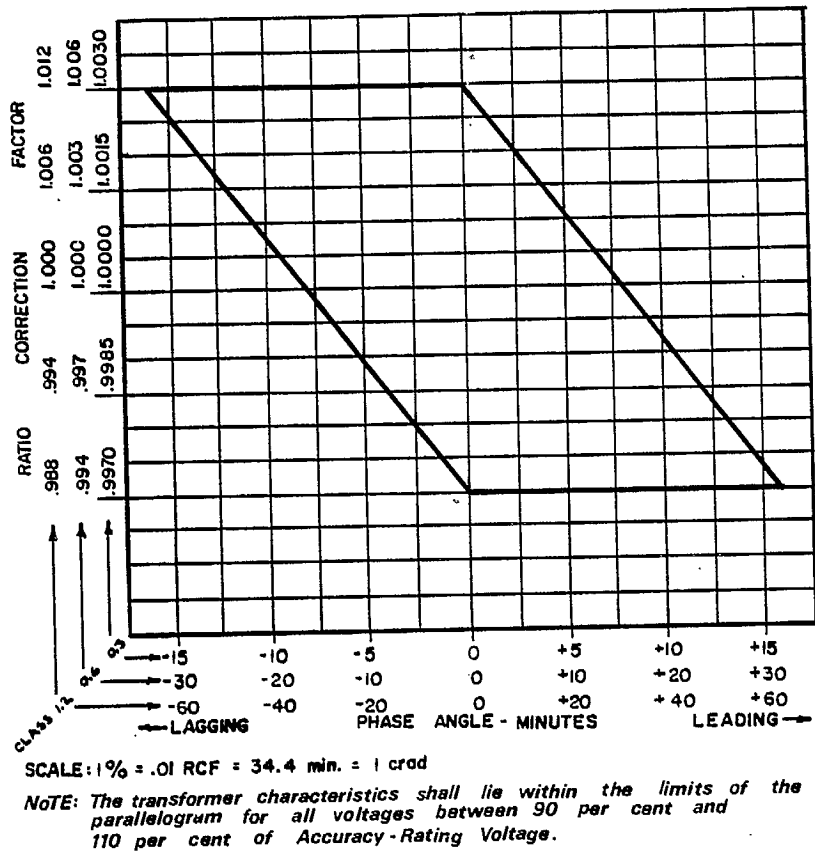

FIGURE 6
LIMITS OF ACCURACY CLASSES

14-5.2.4 Assignment of Accuracy Rating. A voltage transformer shall be assigned an accuracy class rating for each of the standard burdens for which it is designed. For example, an accuracy rating may be 0.3X, 0.3Y, 0.6Z, 0.6ZZ in which case the nameplate shall be marked 0.3Y, 0.6ZZ. With such marking the accuracy at zero burden shall be 0.3. The nameplate marking shall be such as to specify clearly the accuracy which the user may expect.

14-5.2.5 Multi-Ratio Transformers. Where a single accuracy designation is specified for transformers with secondary and tertiary windings (in the form "0.3Z" for example) the accuracy requirement shall only apply to the secondary winding when the tertiary winding is not loaded, to the tertiary winding when the secondary winding is not loaded, and to both windings when the designated burden is divided in any proportion between the two windings. Where a double accuracy designation is specified (in the form "0.6Z-0.6Z" for example) the first designation shall apply to the secondary winding and the other to the tertiary winding. The accuracy requirement for the secondary winding shall apply when the tertiary winding is either not loaded or loaded with its designated burden, and the accuracy requirement for the tertiary winding shall apply when the secondary winding is either not loaded or loaded with its designated burden.

14-6 CAPACITOR VOLTAGE TRANSFORMERS

14-6.1 Scope. This subsection sets out the requirements, in addition to those in subsection 14-3 and 14-5, which pertain to capacitor voltage transformers.

14-6.2 Markings

14-6.2.1 Assembly. If a capacitor voltage transformer is composed of various components which must be assembled according to a prescribed pattern, each component shall be clearly and permanently marked with a serial number so that proper assembly may be readily checked.

14-6.2.2 Nameplate. The nameplate shall include the following:

- (a) the words "CAPACITOR VOLTAGE TRANSFORMER"
- (b) the capacitance values of C1 and C2 and their serial numbers.

14-6.3 Accuracy

Capacitor voltage transformers equipped with carrier accessories shall meet the specified accuracy rating with and without the accessories in the circuit.

14-7 PHASING TRANSFORMERS

14-7.1 Scope

Phasing transformers shall, in general, meet the requirements set out in subsections 14-3 and 14-5 relating to voltage transformers. For phasing transformers the basis for accuracy classification is different. The special requirements for phasing transformers are set out in this subsection.

14-7.2 Accuracy

14-7.2.1 Basis for Metering Accuracy Classes. Accuracy classes are based on the requirement that the error in var or var hour measurement due to the phasing transformer, expressed as a percentage of volt-amperes or volt-ampere hours is within the limit specified by the class designation.

14-7.2.2 Standard Accuracy Classes. Standard accuracy classes shall be 0.3, 0.6, and 1.2. Limiting values of RCF and phase defect for these accuracy classes are shown in Figure 7.

14-7.2.3 Accuracy Rating. Accuracy ratings shall apply for any burden from zero to the rated burden at any voltage between 90 and 110 per cent of the accuracy-rating voltage. All windings shall be burdened equally and simultaneously.

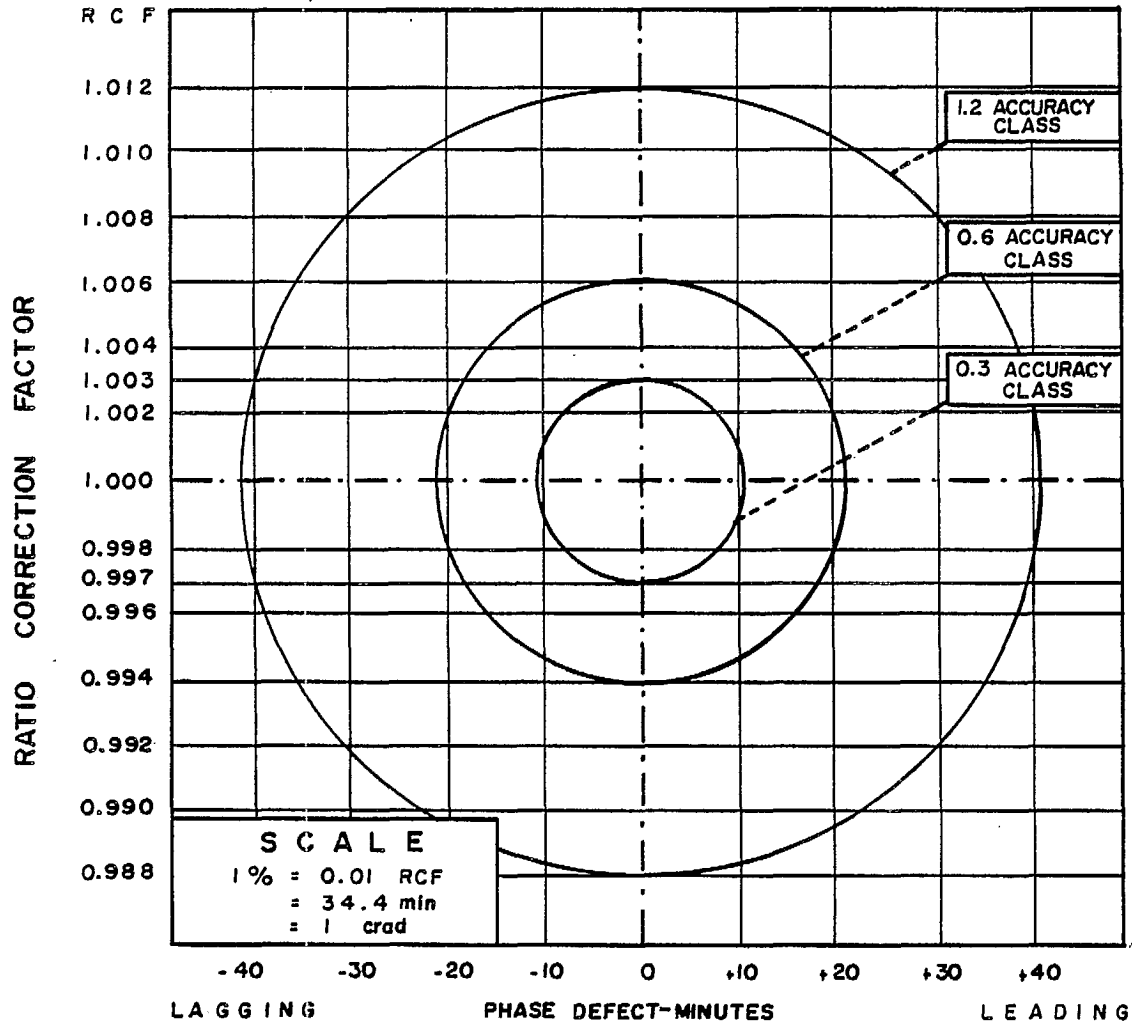

FIGURE 7
STANDARD ACCURACY CLASSES FOR
PHASING TRANSFORMERS
LIMITS FOR 0.3, 0.6 AND 1.2 ACCURACY CLASSES

SECTION 15 - STATIC DEMAND METERS

CONTENTS

	Page
15-1 SCOPE	116
15-2 MECHANICAL REQUIREMENTS	116
15-3 ELECTRICAL REQUIREMENTS	116
15-3.1 Test Links	116
15-3.2 Demand Interval	116
15-3.3 Security	116
15-4 MARKINGS	117
15-4.1 Nameplates	117
15-4.2 Meters Compensated for Line or Transformer Losses	117
15-5 PERFORMANCE REQUIREMENTS	118
15-5.1 Registration at Zero Load	118
15-5.2 Load Performance	118
15-5.3 Variation with Power Factor	118
15-5.4 Balance	118
15-5.5 Effect of Voltage Variation	118
15-5.6 Effect of Variation of Ambient Temperature	119
15-5.7 Effect of an External Magnetic Field	119
15-5.8 Effect of Momentary Overload	119
15-5.9 Polyphase, Individual Elements	119
15-5.10 Balanced Polyphase	119
15-5.11 EMI Susceptibility	119

SECTION 15 - STATIC DEMAND METERS

15-1 SCOPE

These specifications apply to solid state demand meters.

15-2 MECHANICAL REQUIREMENTS

The requirements of subsection 3-2 shall apply.

15-3 ELECTRICAL REQUIREMENTS

15-3.1 Test Links. All self-contained S base meters shall be fitted with test links enabling the isolation of the potential circuits from the current circuits.

15-3.2 Demand Interval. The demand interval shall be not less than 15 minutes. The demand shall be averaged over the demand interval, but it may be recalculated after each update interval.

15-3.3 Security. The requirements of clause 13-6.3 shall apply.

15-4 MARKINGS

15-4.1 Nameplates. In addition to the requirements of clause 3-4.1, the nameplate shall bear the following information:

- i) Rated frequency
- ii) Rated voltage or voltages
- iii) Current range or rating
- iv) Response period or demand interval
- v) Update interval (if applicable)
- vi) Maximum demand rating
- vii) Single-phase test constant (if applicable)
- viii) One of the following:
 - 1-phase, 2-wire,
 - 1-phase, 3-wire,
 - 2-element
 - 2-element network
 - 2-element, 3-phase, 3-wire
 - 2½-element wye
 - 2½-element delta
 - 3-element wye

Note: Accepted symbols are \emptyset , EL, Y, Δ .

- ix) All information essential for determination of the demand from the meter indication.
- x) For primary rated meters; also:
 - (a) Current transformer rating, e.g. CT
1000-5 A
 - (b) Voltage transformer rating, e.g. VT
2400-120 V.
- xi) For single phase transformer type meters the words "Transformer Type" in red.

If the meter is provided with accessories such as retransmitting contacts, etc., the nameplate shall so specify and a diagram of connections shall be provided if considered necessary by the Director.

The markings shall be indelible, distinct, and visible from outside the meter with all covers in place.

Space shall be provided for affixing an inspection number.

15-4.2 Meters Compensated for Line or Transformer Losses. Meters which are internally compensated for line or transformer losses shall have "LOSS COMPENSATED" indelibly marked in red on the nameplate.

15-5 PERFORMANCE REQUIREMENTS

The performance requirements of subsection 15-5 pertain to measured values. Calculated quantities derived from two or more measured values shall meet the requirements of subclause 13-5.1.2.

15-5.1 Registration at Zero Load. Under the reference conditions specified in clause 3-5.1, and with zero current applied, the output shall not exceed 0.1% of the maximum rated demand.

15-5.2 Load Performance. Under reference conditions and at unity power factor, for any current between 10% and 100% I_{max} , the device shall register the load to within $\pm 0.5\%$ of the true value.

15-5.3 Variation with Power Factor. Under reference conditions, and at 0.5 leading and lagging power factors, for any current between 10% and 100% I_{max} , the device shall register the load to within $\pm 0.75\%$ of the true value.

15-5.4 Balance. Under reference conditions specified in clause 3-5.1, with only one current circuit energized with its maximum rated current, the output demand reading shall be noted. This shall be repeated with each individual current circuit being energized in turn. The difference between any two readings shall not exceed 0.5% of the true value.

15-5.5 Effect of Voltage Variation. With the meter energized under reference conditions and with the current circuits carrying 50% of maximum load, the output demand reading shall be checked with the applied voltage 10% above and 10% below the nameplate rating. The auxiliary supply voltage shall be simultaneously varied in the same way. The error of indication shall not increase by more than 0.2% at unity power factor nor by more than 0.4% at 0.5 lagging power factor and 0.866 leading power factor.

15-5.6 Effect of Variation of Ambient Temperature. The maximum allowable influence due to variation in ambient temperature shall be no more than 0.03% of true value per °C.

This influence shall be determined by comparing the performance under reference conditions with that at -40°C and +53°C or at the temperature extremes specified on the nameplate, whichever is less.

15-5.7 Effect of External Magnetic Field. The change in the metering error at 50% I_{max} shall not exceed ±1.0% of true value when the meter is subjected to an external magnetic field. The magnetic field shall be equivalent to that produced by a coil one metre in diameter having a magnetomotive force of 400 ampereturns. The frequency of the coil current is to be the same as that applied to the meter. The phase of the coil current and the orientation of the coil shall be such as to produce the maximum effect. For polyphase meters, the test voltages and currents shall be balanced polyphase.

15-5.8 Effect of Momentary Overload. With all potential circuits energized and with current circuits connected series assisting, the meter shall be subjected to a current equal to 10 times I_{max} for 0.5 seconds. After the application of this short time potential circuits energized following which the meter shall be tested for variation of error at 50% I_{max} at unity power factor. The variation in error shall not exceed ±0.5% of true value.

15-5.9 Polyphase Individual Elements. With the potential circuits energized with balanced polyphase voltages and only one individual current circuit carrying its maximum rated current to give a constant load, the output demand reading shall be accurate to ±0.75% of the true value at unity power factor, and accurate to ±1% of true value at 0.5 lagging power factor.

15-5.10 Balanced Polyphase. With balanced polyphase currents and voltages applied to the meter, and at any current between 10% and 100% I_{max} , the meter shall be accurate to within ±0.75% of true value at unity power factor, and within ±1.0% at 0.5 leading and lagging power factors.

15-5.11 EMI Susceptibility. Meters shall be subject to the EMI susceptibility tests set forth in clause 3-5.2.

**SECTION 16 - INDUCTION TYPE
VOLTAGE-SQUARED HOUR METERS**

CONTENTS

	Page
16-1 SCOPE	121
16-2 MECHANICAL REQUIREMENTS	121
16-3 ELECTRICAL REQUIREMENTS	121
16-3.1 Disc Speed	121
16-3.2 Insulation	121
16-4 MARKINGS	122
16-4.1 Nameplates	122
16-5 PERFORMANCE REQUIREMENTS	122
16-5.1 Accuracy	122
16-5.2 Effect of Variation of Ambient Temperature	122
16-5.3 Effect of External Magnetic Field	122
16-5.4 Polyphase Energization	123
16-5.5 Effect of Self-Heating	123
16-5.6 Effect of Tilt	123

**SECTION 16 - INDUCTION TYPE
VOLTAGE-SQUARED HOUR METERS**

16-1 SCOPE

The requirements of this section apply to primary and secondary rated voltage-squared hour ($V^2.h$) meters of the induction type.

16-2 MECHANICAL REQUIREMENTS

Meters shall comply with the requirements of subclauses 4-2.1.1 and 4-2.2.1.

16-3 ELECTRICAL REQUIREMENTS

16-3.1 Disc Speed. The speed of the disc shall not exceed 100 revolutions per minute when the meter is operating at its rated voltage.

16-3.2 Insulation. The requirements of clause 3-3.4 shall apply with the exception that the test voltage stated in subclause 3-3.4.2 shall be 2.5kV.

16-4 MARKINGS

16-4.1 Nameplates. In addition to the requirements of clause 3-4.1, the nameplate shall bear the following information.

- i) Rated frequency
- ii) Rated voltage
- iii) Number of elements
- iv) For secondary-rated meters, the single phase test constant and the pulse constant K_p in $V^2.h$ per pulse
- v) For primary rated meters
 - a. Voltage transformer ratio
 - b. Pulse constant K_p in $V^2.h$ per pulse

16-5 PERFORMANCE REQUIREMENTS

16-5.1 Accuracy. Under reference conditions specified in clause 3-5.1 and over the metering range of $\pm 15\%$ of the rated voltage the metering error shall not exceed $\pm 1.0\%$ of true value.

16-5.2 Effect of Variation of Ambient Temperature. The maximum allowable influence due to variation in ambient temperature shall not exceed 0.06% of true value per $^{\circ}C$ at $25\% I_{max}$.

This influence shall be determined by comparing the performance under reference conditions with that at $-40^{\circ}C$ and $+53^{\circ}C$, or at the temperature extremes specified on the nameplate, whichever is less.

16-5.3 Effect of External Magnetic Field. The change in the metering error at rated voltage shall not exceed 1.0% of true value when the meter is subjected to an external magnetic field. The magnetic field shall be equivalent to that produced by a coil one metre in diameter having a magnetomotive force of 400 ampere-turns. The frequency of the coil shall be the same as that applied to the meter. The phase of the metered voltage and the orientation of the coil shall be such as to produce the maximum effect. For polyphase meters, the voltages shall be balanced polyphase.

16-5.4 Polyphase Energization. Polyphase meters shall be tested for accuracy at rated voltage with balanced polyphase voltages. The metering error shall not differ from that established pursuant to clause 16-5.1 by more than +0.3%.

16-5.5 Effect of Self-Heating. Sustained operation at rated voltage under single phase conditions shall not change the metering error by more than 0.5% from that determined within two minutes of the application of the metered voltage.

16-5.6 Effect of Tilt. At rated voltage and under single phase conditions, tilting the meter up to 3° from the vertical shall not change the metering error by more than 1.0% from that determined according to clause 16-5.1.

SECTION 17 - STATIC VOLTAGE-SQUARED HOUR METERS

CONTENTS

	Page
17-1 SCOPE	125
17-2 MECHANICAL REQUIREMENTS	125
17-3 ELECTRICAL REQUIREMENTS	125
17-3.1 Testing	125
17-4 MARKINGS	126
17-4.1 Nameplate	126
17-5 PERFORMANCE REQUIREMENTS	126
17-5.1 Registration at Zero Voltage	126
17-5.2 Performance Accuracy	126
17-5.3 Effect of Variation of Ambient Temperature	126
17-5.4 Effect of External Magnetic Field	127
17-5.5 Polyphase Energization	127
17-5.6 EMI Susceptibility	127

SECTION 17 - STATIC VOLTAGE-SQUARED HOUR METERS

17-1 SCOPE

The requirements of this section apply to primary and secondary rated solid-state voltage-squared hour (V².h) meters.

17-2 MECHANICAL REQUIREMENTS

The requirements of subsection 3-2 shall apply.

17-3 ELECTRICAL REQUIREMENTS

17-3.1 Testing. Each meter shall be provided with a testing means to facilitate calibration (in a manner analogous to counting the disc revolutions of an induction type meter).

This testing means shall provide at least 5 pulses (or other indications) per minute when operating at the rated nameplate voltage under single phase reference conditions specified in clause 3-5.1.

17-4 MARKINGS

17-4.1 Nameplates. In addition to the requirements of clause 3-4.1, the nameplate shall bear the following information:

- i) Rated frequency
- ii) Rated voltage
- iii) Number of elements
- iv) For secondary-rated meters, the single phase test constant and the pulse constant K_p in $V^2 \cdot h$ per pulse
- v) For primary rated meters
 - a. Voltage transformer ratio
 - b. Pulse constant K_p in $V^2 \cdot h$ per pulse

17-5 PERFORMANCE REQUIREMENTS

17-5.1 Registration at Zero Voltage. Under the reference conditions set out in clause 3-5.1 and with no voltage applied, the registration shall not increase by more than one division of the lowest reading drum, dial or digit over a four hour period. Meters with pulse initiators shall not produce more than one output pulse over a four hour period.

17-5.2 Accuracy. Under reference conditions and over the metering range of $\pm 20\%$ rated voltage, the metering error shall not exceed $\pm 0.5\%$ of true value.

17-5.3 Effect of Variation of Ambient Temperature. The maximum allowable influence due to variation in ambient temperature shall not exceed 0.05% of true value per $^{\circ}C$ at rated voltage.

This influence shall be determined by comparing the performance under reference conditions with that at $-40^{\circ}C$ and $+53^{\circ}C$ or at the temperature extremes specified on the nameplate, whichever is less.

17-5.4 Effect of External Magnetic Field. The change in the metering error at rated voltage shall not exceed +1.0% of true value when the meter is subjected to an external magnetic field. The magnetic field shall be equivalent to that produced by a coil one metre in diameter having a magnetomotive force of 400 ampere-turns. The frequency of the coil is to be the same as that applied to the meter. The phase of the metered voltage and the orientation of the coil shall be such as to produce the maximum effect. For polyphase meters, the voltages shall be balanced polyphase.

17-5.5 Polyphase Energization. Polyphase meters shall be tested for accuracy at rated voltage with balanced polyphase voltages. The error shall not differ from that established pursuant to clause 17-5.2 by more than +0.1%.

17-5.6 EMI Susceptibility. Meters shall be subject to the EMI susceptibility tests set forth in clause 3-5.2.

SECTION 18 - SUB-METERING

CONTENTS

	Page
18-1 SCOPE	129
18-2 MECHANICAL REQUIREMENTS	129
18.2.1 General	129
18.2.2 Nameplate Location	129
18.2.3 Current Sensing Transformers	129
18-3 ELECTRICAL REQUIREMENTS	130
18-3.1 General	130
18-3.2 Metering Configuration	130
18-4 MARKINGS	130
18-4.1 Nameplates	130
18-5 PERFORMANCE REQUIREMENTS	130
18-5.1 Deviation between Channels	130

SECTION 18 SUB-METERING

18-1 SCOPE

These specifications apply to metering systems or devices used to apportion a total electricity bill among several customers.

18-2 MECHANICAL REQUIREMENTS

18-2.1 General. The load of each individual customer shall be metered by approved metering devices. The applicable requirements are set out in other sections of these specifications.

18-2.2 Nameplate Location. The nameplate shall be affixed to the exterior of the cabinet of the system master processor.

18-2.3 Current Sensing Transformers. Systems using ring current transformers for sensing the current drawn by a load shall use transformers of such a size that will, with the transformers installed in service, allow for 5 additional turns of #16 wire to be threaded around the core for testing purposes.

18-3 ELECTRICAL REQUIREMENTS

18-3.1 General. The data processing system shall provide the following information:

- i) The total energy consumed by all customers being apportioned.
- ii) The energy consumed by each individual customer during the billing period.
- iii) The percentage of the total bill applicable to each customer.

The above shall be stored electronically or by some other means for the minimum period set out in the Electricity and Gas Inspection Regulations.

18-3.2 Metering Configuration. In order to facilitate accurate testing, the metering circuit shall be configured as follows:

- i) So the meter and associated sensors and transformers may be removed from the circuit for testing, or:
- ii) So a portable metering standard can be inserted into the circuits.

18-4 MARKINGS

18-4.1 Nameplates. In addition to the requirements of other applicable sections, the nameplate shall include the following data:

- i) The transfer constant of the meter sensor, i.e. the value of the measured quantity per unit of sensor output.
- ii) The maximum permissible length of a single conductor between the load sensor and the associated meter, and the applicable wire size.
- iii) The load range of the sensor
- iv) The nominal metering voltage.
- v) Space to mark the number of customers being apportioned.

18-5 PERFORMANCE REQUIREMENTS

18-5.1 Deviation between Channels. With equal loads applied to all channels between minimum and maximum, the deviation of output readings between any two channels shall not be greater than $\pm 1.0\%$ of the true value.

SECTION 19 SIGNAL CONVERTERS

CONTENTS

	Page
19-1 SCOPE	132
19-2 MECHANICAL REQUIREMENTS	132
19-3 ELECTRICAL REQUIREMENTS	132
19-4 MARKING	132
19-4.1 Nameplate	132
19-5 PERFORMANCE REQUIREMENTS	132
19-5.1 Accuracy at Reference Conditions	132
19-5.2 Zero Drift	133
19-5.3 Effect of Voltage Variation	133
19-5.4 Effect of Variation of Ambient Temperature	133
19-5.5 EMI Susceptibility	133

SECTION 19 SIGNAL CONVERTERS

19-1 SCOPE

These specifications apply to devices not covered in other sections which convert an electrical signal from one form into another. For example, this section includes, but is not restricted to, analog-to-digital converters, and analog-to-frequency converters.

19-2 MECHANICAL REQUIREMENTS.

The requirements of subsection 3-2 shall apply.

19-3 ELECTRICAL REQUIREMENTS

The requirements of subsection 3-3 shall apply.

19-4 MARKINGS

19-4.1 Nameplate. In addition to the requirements of clause 3-4.1, the nameplate shall bear the following information:

- i) Type of input and output.
- ii) Range of input(s)
- iii) Relationship of output to input
- iv) A connection diagram, if considered necessary by the Director.

19-5 PERFORMANCE REQUIREMENTS

19-5.1 Accuracy at Reference Conditions. For any input between minimum and maximum, the output shall reflect the input to within $\pm 0.1\%$ of reading.

19-5.2 Zero Drift. With the input supplied with a signal corresponding to the zero of the quantity being metered, the error of the output of the device shall not exceed 0.1% of the rated maximum at any time during a four hour period.

19-5.3 Effect of Voltage Variation. With the input signal at mid range between minimum and maximum, the auxiliary voltage shall be varied 10% above and below the value marked on the nameplate. The error of the output shall not exceed $\pm 0.1\%$ of reading.

19-5.4 Effect of Variation of Ambient Temperature. The maximum allowable influence due to variation in ambient temperature shall be $\pm 0.01\%$ fo full scale value per °C.

19-5.5 EMI Susceptibility. Devices shall be subject to the requirements of clause 3-5.2.

