

Solving Interference Problems

IC

LKC  
TK  
6553  
.S66  
1991  
c.2

Technical handbook

Canada

# SOLVING INTERFERENCE PROBLEMS

Industry Canada  
Library - Queen

MAY - 3 2013

Industrie Canada  
Bibliothèque - Queen

~~COMMUNICATIONS CANADA  
MAY 8 1991  
LIBRARY - BIBLIOTHÈQUE~~

## WARNING

This booklet is for the use of electronic equipment service technicians and others who are familiar with electronics. Because of the danger of electric shock, all modification of electrical and electronic equipment should be performed by a qualified technician.

## CAUTION

In order to take advantage of the explanations and information in this handbook, it is important to have clearly identified the phenomenon affecting the equipment. It is therefore recommended that the handbook *Radio and Television Interference*, published by Communications Canada, be read first.

The illustrations of circuits and devices shown in this document are provided as examples only and should not be considered exhaustive. Although they can eliminate interference problems, the proposed circuits and methods may affect the performance of the appliance. Thus, it is important to know these performance characteristics and to adapt modifications to them.

© Minister of Supply and Services Canada 1991

Cat. No. Co22-103/1991E

ISBN 0-662-18755-5 ✓

Design by: Ove Design Ottawa

JK DL 10584880  
6553 DL 10585383  
5660  
1991



Ce texte est aussi disponible en français

---

# Contents

<b>Introduction</b>	<b>1</b>
What is interference?	1
Why interference occurs	1
<b>1 Understanding and eliminating audio rectification interference</b>	<b>3</b>
What is it?	3
How and why it occurs	3
What to do	3
Tracking it down	4
Entry via the power-line cord	5
Entry via speaker wires	7
Entry via interconnecting wiring	7
Filtering amplifier stages	9
<b>2 Interference from electrical devices or appliances</b>	<b>13</b>
Typical sources	13
Analyzing the interference	19
General information	20
<b>3 Television interference from radio transmitters</b>	<b>21</b>
Checking the radio transmitter	21
Checking the television antenna system	25
Checking the television receiver	26
Elimination methods	27
<b>4 Factors affecting reception</b>	<b>32</b>
Modes of propagation	32
Receiver installation	32
The antenna	34
Reception difficulties	36
<b>Appendices</b>	<b>41</b>

---

---

## List of figures

<i>No.</i>	<i>Title</i>	<i>Page</i>
1.1	Potential radio-frequency interference entry points in a stereo system	5
1.2	Use of a ferrite core to block RF signals	6
1.3	Commercial plug-in ac line filter	6
1.4	Three schematics for ac filters	6
1.5	Shielded audio cable	7
1.6	Method for connecting shielded speaker leads, showing grounding technique for braided shield	7
1.7	Unshielded speaker leads wound on a ferrite core	8
1.8	By-passing speaker leads	8
1.9	Installation of ferrite bead on speaker lead	8
1.10	Installation of shielded cable from amplifier input socket to printed circuit board	9
1.11	Troubleshooting chart for radio-frequency interference (RFI) problems in a stereo system (part 1)	10
1.12	Troubleshooting chart for RFI problems in a stereo system (part 2)	11
1.13	Installation of capacitor from base to emitter and at speaker terminals	12
2.1	Spark eliminator circuit	14
2.2	Installation of a capacitor in a typical thermostat	14
2.3	Suppression of interference originating in the firing systems of most modern oil or gas furnaces	14
2.4	Four possible locations for suppressing interference from a light dimmer	15
2.5	Installation of capacitors in fluorescent lighting	16
2.6	Installation of a line filter in the transformer of a neon light and 10 kohm resistors in series with each high-voltage wire	16
2.7	Side view of a typical armature; arcs (sparks) are produced between the commutator and each brush	17

---

---

2.8	End view of a motor armature showing location of capacitors	17
2.9	Suppression of interference originating in a sewing machine	18
3.1	Guide for locating transmitter interference	22
3.2	Relationship between VHF television channels and radio stations that might produce interference	23
3.3	Spectrum analyzer measuring harmonic radiation	24
3.4	Standing wave ratio (SWR) meter measuring harmonic radiation	24
3.5	Ensuring a proper ground	24
3.6	Operating a transmitter with a shielded dummy load	25
3.7	Installation of a low-pass filter in an antenna lead	25
3.8	Installation of high-pass filters in antenna systems	26
3.9	Installation of a high-pass filter in a television	27
3.10	Installation of a high-pass filter at television antenna inputs	27
3.11	Various high-pass and low-pass filters	28
3.12	Use of quarter-wave stubs to eliminate interference	28
3.13	Installation of a tunable stub trap by taping it to the 300 ohm antenna ribbon	31
4.1	Antenna installation with lightning rod	33
4.2	Installation of antenna lead-in wire	34
4.3	Different types of antennas	35
4.4	Reflection of a television signal	37
4.5	Adjacent channel interference	38
4.6	Co-channel interference	38

---

## Introduction

This handbook is a guide to the causes of radio interference. It also includes methods for eliminating interference from radios, televisions, audio playback equipment, and several non-radio appliances.

### What is interference?

Interference is broadly defined as any modification to the reception of sound or picture signals that makes them unacceptable. Interference can originate from a variety of sources. Electrical and electronic appliances in homes, offices and industry, neon signs, motor vehicle ignition systems, medical equipment, power lines, and radio transmitters all contribute background noise that can interfere with radio and television reception. This problem is compounded by the fact that many radios and televisions were not designed to operate in today's radio-frequency environment, in which the number of electrical devices and radio transmissions has greatly increased.

Most interference falls into one of three categories:

- 1 Interference from electrical devices or appliances;
- 2 Interference caused by radio transmitters;
- 3 Swamping (for information about this type of interference, please consult the handbook *Radio and Television Interference*, published by Communications Canada).

### Why interference occurs

When an electronic device picks up interference, the problem is often assumed to be the fault of the radio transmitting source. But, in fact, the affected equipment often lacks the circuitry required to operate properly in the presence of radio signals, or it has a defect that makes it susceptible to interference.

Furthermore, there is a constant demand for new radio services on an already crowded radio spectrum. Under these circumstances, it is essential that the whole system work properly and that all radio-communication equipment be

maintained within the standards for each service. If one transmitter in a network develops a fault that results in spurious emissions, then many other services will probably be affected.

When interference problems are investigated, equipment at the source of the interference is usually found to be operating normally and within technical specifications. However, the affected device, because of poor design, construction or installation, experiences interference. There may be a simple and economical solution to the problem; if not, it may be necessary to replace the equipment.

With this in mind, the following guidelines are provided to assist in understanding interference, how it affects receiving equipment and how it can be suppressed.

Specifically, this guide will deal with interference affecting:

- devices that use radio waves (television and radio); and
- entertainment devices (stereo systems).



# 1 Understanding and eliminating audio rectification interference

## What is it?

Audio rectification interference occurs when an electronic circuit (usually an amplifier), which ideally should respond only to audio-frequency signals, responds to external radio-frequency (RF) signals. Typically, the circuit picks up signals from a nearby radio transmitter in addition to the sound the listener wants to hear. The unwanted signal may be constant or intermittent, faint or uncontrollably loud.

Televisions, radios, stereos, electronic organs and public address systems can all be prone to audio rectification interference. When audio rectification occurs, it indicates that the device lacks sufficient shielding or filtering to function properly when close to strong radio signals. These problems are now commonplace in residential areas where radio use by the public and industry is on the increase.

## How and why it occurs

Audio devices are designed to amplify audio signals such as music or speech. They are not intended to function as receivers of radio signals. When an audio device is close to an operating radio transmitter, it is enveloped in a strong radio-frequency field. Under these conditions, the wiring that connects the circuitry and components in the system may act as antennas that couple the radio signal into the audio amplifier. When this occurs, the strong radio-signal energy entering the audio circuitry overloads the amplifier, is rectified and amplified, and emerges from the speaker as undesirable sound. This process takes place entirely within the affected device and must be prevented or suppressed within the device.

## What to do

Radio interference resulting from an audio device responding to signals from a nearby radio station transmitter is not generally caused by improper operation of or technical deficiencies in the transmitter. The solution to such problems is to modify the affected audio device.

## Tracking it down

Although the elimination of radio interference depends on the specific circumstances of the problem, there are certain basic procedures to follow:

- 1 Unplug all accessory items, for example, external speakers, phono leads, motor leads (see Figure 1.1). If the interference disappears, plug the leads back in one at a time until the interference reappears. This will identify the accessory causing the trouble. Decoupling this accessory with a 0.001 microfarad capacitor, either across or from each lead to ground, will usually cut out the interference. The leads of the capacitor should be as short as possible and the rated voltage at least 1 kV.
- 2 If unplugging the various leads does not stop the interference, then determine which section of the unit is doing the detecting. Try the volume control at minimum. If the interference persists then it must be in the section from the volume control to the speakers. If speaker wires are unshielded, replace them with shielded audio cable. It may also be necessary to connect the braided shielding to ground.
- 3 Next, where possible, try grounding each speaker housing. If the interference is reduced, fit grounds to all speaker housings.
- 4 If the interference persists, try fitting 100 picofarad capacitors between the base and emitter of each driver transistor. Again, the leads of the capacitor should be as short as possible. Each time the interference is reduced, leave the capacitor in place. Although one channel may pick up more interference than the other, it is a good idea to decouple both channels at the same time. Each capacitor must be soldered in, as bridging each transistor by hand will not be effective. The idea is to put each offending junction at the same radio-frequency level. This is the reason for connecting the base and emitter of each stage with a capacitor.

After following these steps, the interference should be eliminated or at least reduced to an acceptable level.

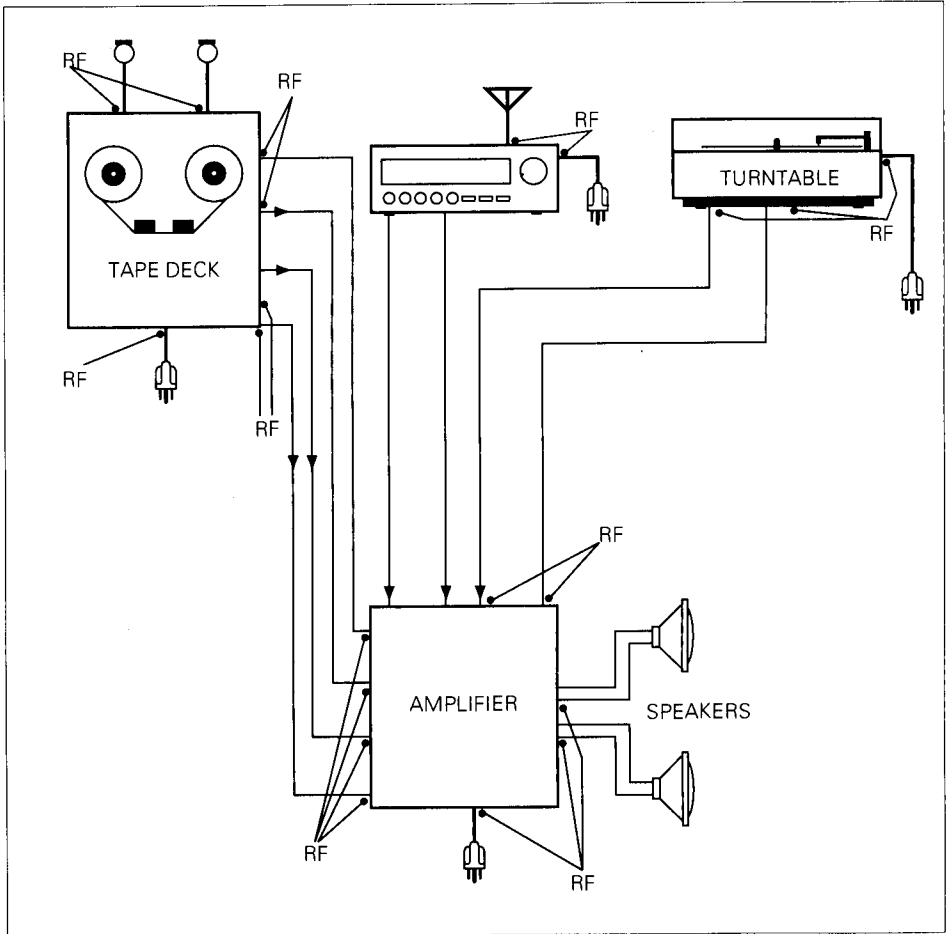

Figure 1.1 Potential radio-frequency interference entry points in a stereo system

### Entry via the power-line cord

Wiring in a home can couple significant levels of radio signals into an audio device via the power line. A simple test to determine if

this is the case is to pull the plug from the outlet while the interference is present. Normally, the charged capacitors in the power supply will keep the unit on for a short period. If the interference stops immediately when the

power plug is pulled, suspect entry via the power line. Follow these steps to suppress such interference.

- 1 Wind the power cord into an inductor to block the RF signal. A ferrite core may be used (see Figure 1.2).

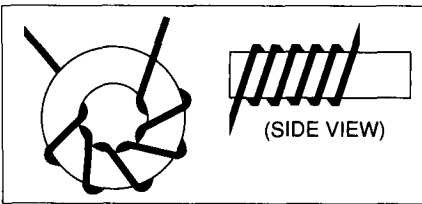

Figure 1.2 Use of ferrite core to block RF signals

- 2 Install a commercially available ac line filter (see Figures 1.3 and 1.4).

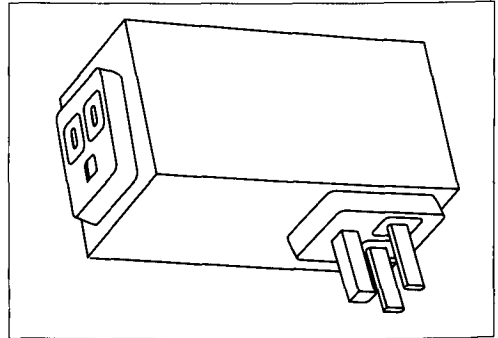

Figure 1.3 Commercial plug-in ac line filter

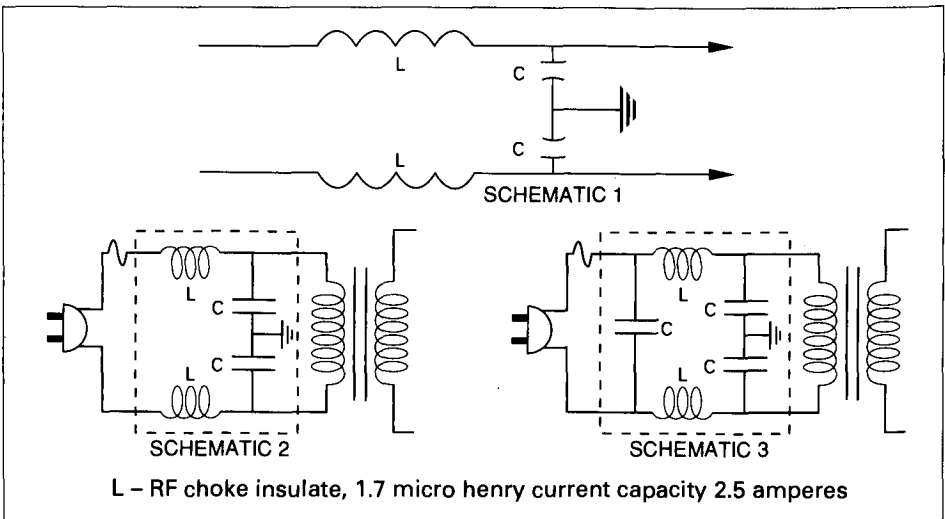

Figure 1.4 Three schematics for ac filters

## Entry via speaker wires

Speaker wires can pick up radio signals and couple them into the amplifier. This is common in stereo systems and results in interference,

regardless of the program source (for example, tuner, tape player, turntable).

A first step that may be effective in dealing with such interference is to ensure the speaker leads are as short as possible. If this does not help, it may be necessary to replace the speaker wires with shielded audio cable as shown in Figure 1.5 and installed as shown in Figure 1.6. Unshielded speaker leads may be wound around a ferrite core (see Figure 1.7) or by-passed (see Figure 1.8).

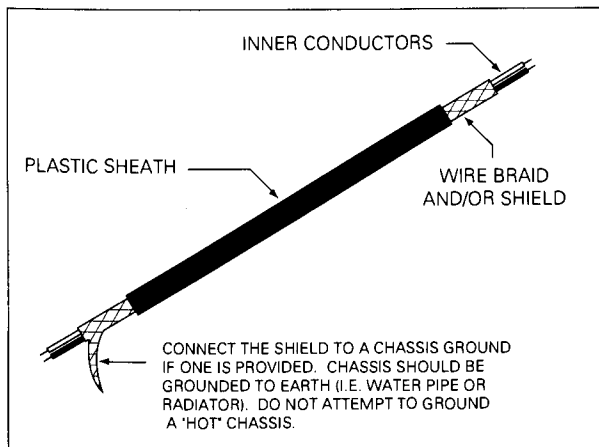

Figure 1.5 Shielded audio cable

## Entry via interconnecting wiring

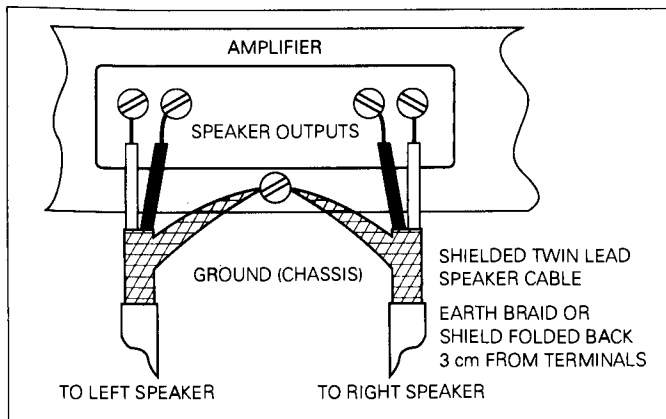

Figure 1.6 Method for connecting shielded speaker leads, showing grounding technique for braided shield

Ambient radio signals can also enter through wiring between circuits and components. In stereo systems, this type of interference occurs only when one particular program source, such as the turntable, is selected. In such cases, the

interference disappears when the interconnecting wires for the program source are disconnected.

To deal with such interference, first eliminate any excess wire. Next, grounding the outer conductor of an audio cable to the chassis of a component may reduce or

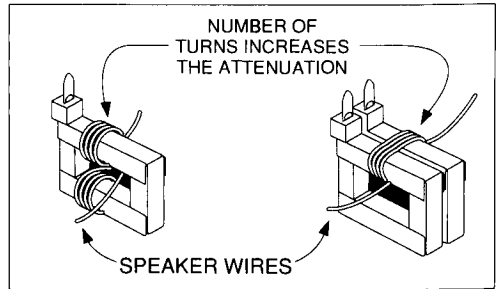

Figure 1.7 Unshielded speaker leads wound on a ferrite core

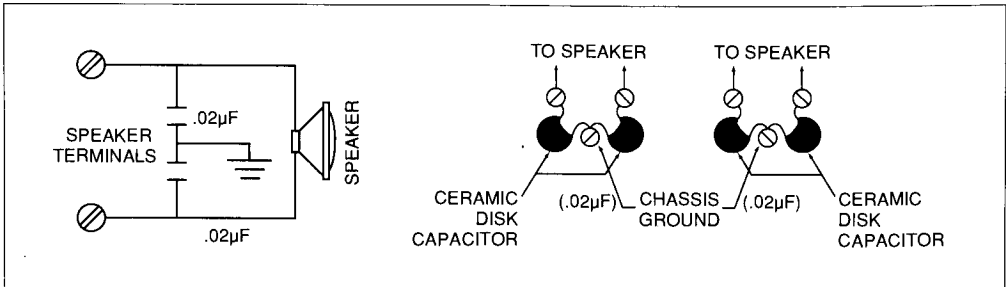

Figure 1.8 By-passing speaker leads

eliminate the problem. If this results in a hum, the ground connection should be made through a 200-1000 picofarad capacitor. If this is not totally effective, consider replacing the wire with properly shielded cable, or using a ferrite bead as shown in Figure 1.9.

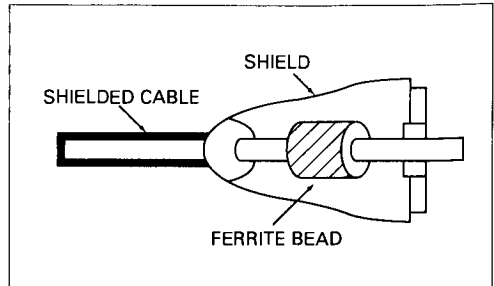

Figure 1.9 Installation of ferrite bead on speaker lead

### Filtering amplifier stages

In particularly difficult instances, it may be necessary to isolate the stage or component that is rectifying the signal. This is largely a process of elimination. An oscilloscope, if available, can be used to identify the offending stage. If adjusting the volume control varies the level of the interfering signal, look at the preceding stages. It may be necessary to replace unshielded input leads from the amplifier input socket

to the amplifier printed circuit board with shielded cable (see Figure 1.10). Generally, though, a small capacitive by-pass from base to emitter, as shown in Figure 1.13, is all that is required.

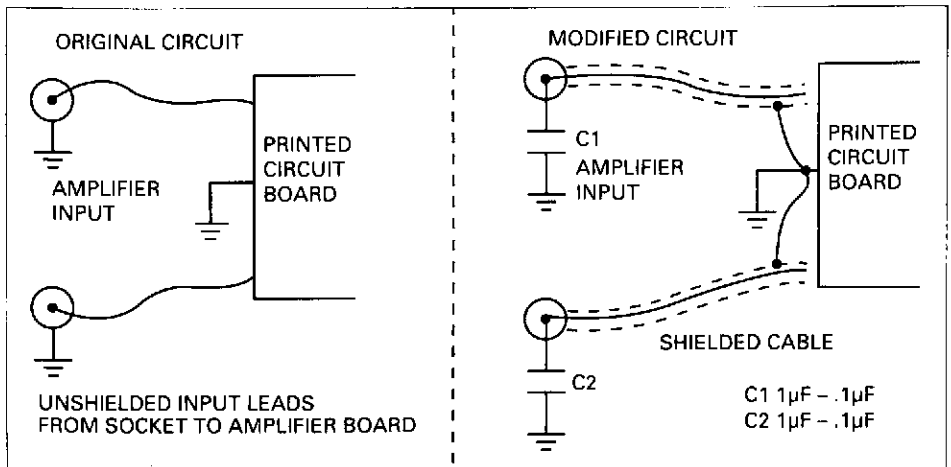

Figure 1.10 Installation of shielded cable from amplifier input socket to printed circuit board

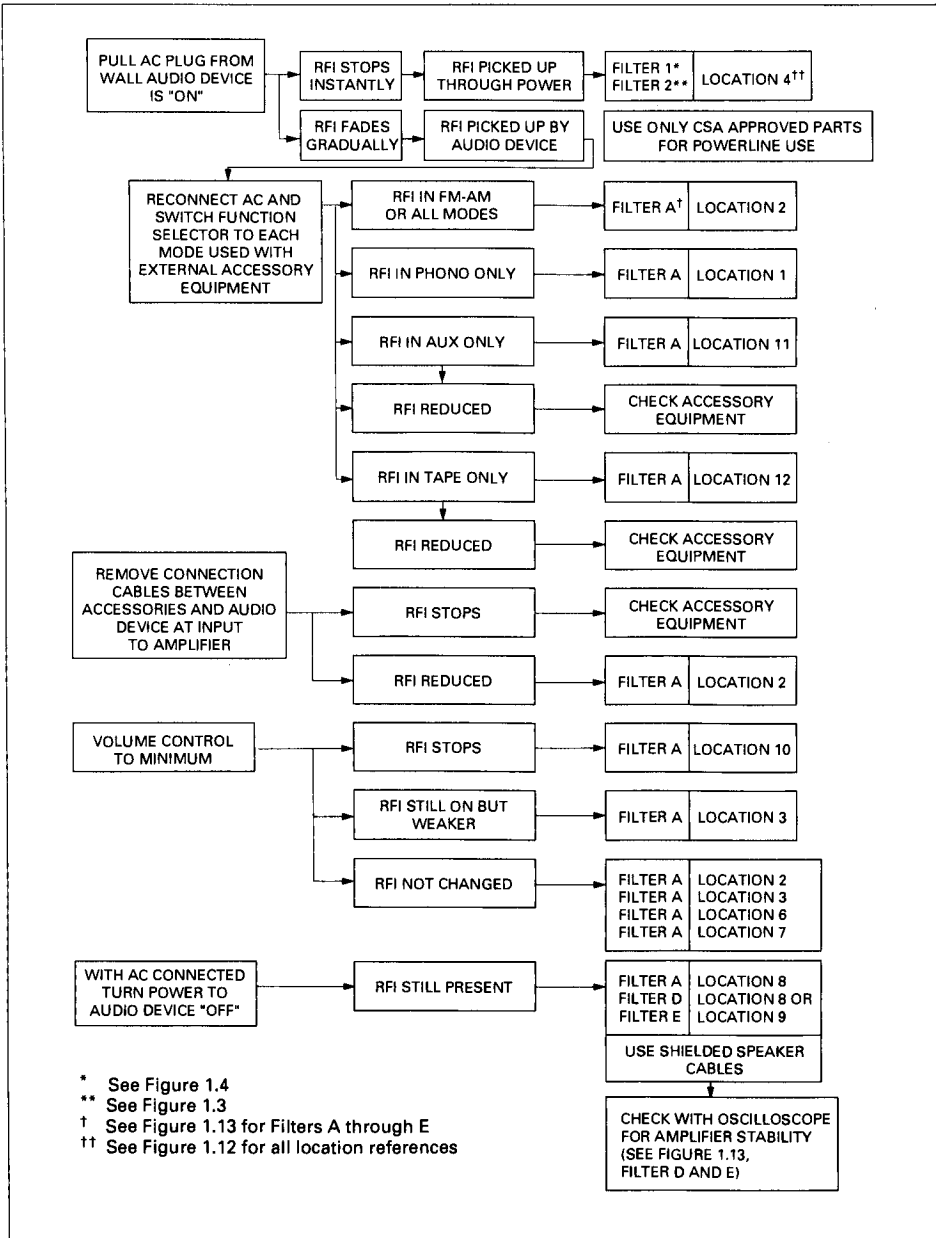
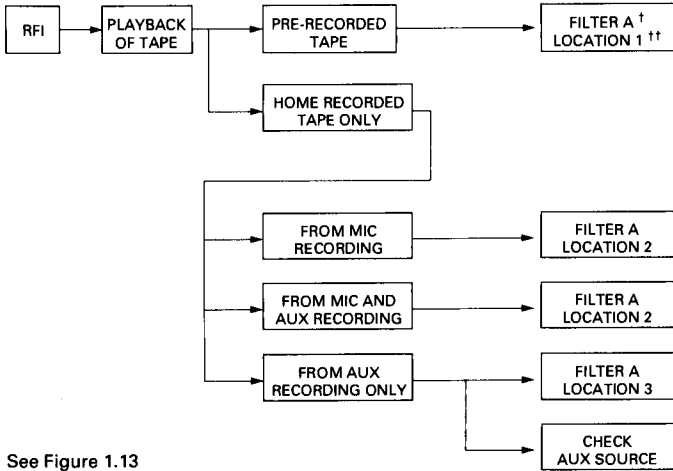

Figure 1.11 Troubleshooting chart for radio-frequency interference (RFI) problems in a stereo system (part 1)



TAPE DECK OR TAPE SECTION OF AUDIO EQUIPMENT



† See Figure 1.13  
 †† See location references below

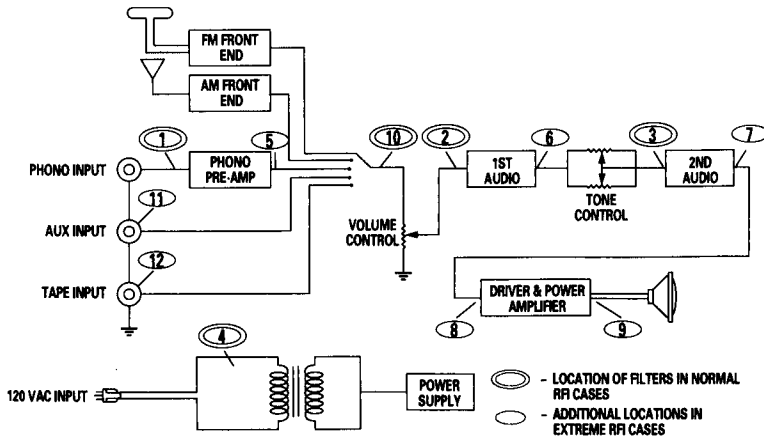
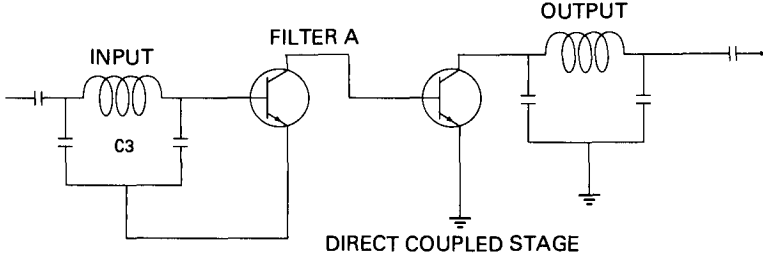
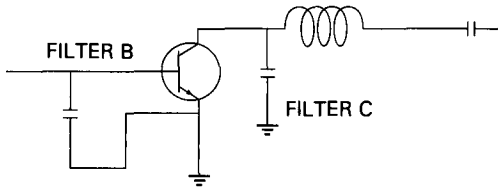

Figure 1.12 Troubleshooting chart for RFI problems in a stereo system (part 2)

**FILTER A** THE MOST EFFECTIVE RFI FILTER FROM PRACTICAL EXPERIENCE IS A PI ( $\pi$ ) FILTER NETWORK CONSISTING OF A SERIES RF COIL AND TWO SHUNT CAPACITORS



**FILTER B** IN MILD CASES OF RFI A SINGLE BY-PASS CAPACITOR BETWEEN THE BASE AND EMITTER MAY BE SUFFICIENT



**FILTER C** AN L-TYPE FILTER IN THE COLLECTOR CIRCUIT IS ANOTHER WAY TO SUPPRESS RFI

INTERFERENCE CAUSED BY LONG SPEAKER CABLES CAN BE SUPPRESSED USING FILTER D OR FILTER E

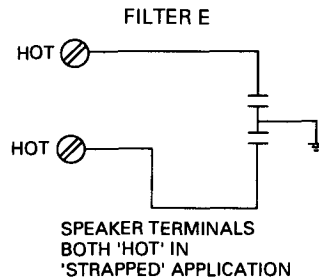
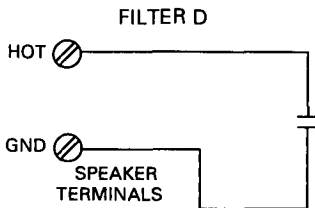

Figure 1.13 Installation of capacitor from base to emitter and at speaker terminals

## 2 Interference from electrical devices or appliances

Electrical devices and appliances used around the home frequently interfere with radio and television reception, producing crackling, clicking, humming or buzzing in the sound, and tears, dots and lines in the picture. Since these appliances are only operated when needed, this type of interference tends to be intermittent, rather than continuous.

### Typical sources

#### Motor vehicles

The ignition systems of some automobiles can interfere with radio and television reception. In such cases, an efficient antenna and optimal antenna orientation can reduce interference by improving the signal-to-noise ratio. It should be noted, however, that this interference cannot be adequately suppressed at the television or radio receiver. For suppression to be effective, it must be applied to the motor vehicle causing the interference. Suppressors for ignition systems are available commercially.

#### Electrical appliances

Electrical appliances can interfere with television reception, but normally interference at the high frequencies used for television is not as objectionable as the interference these appliances can produce in AM and FM radio reception.

Nevertheless, the following may interfere with television reception:

- Loose connections in wiring, outlet receptacles, appliance cords, and so on.
- Incandescent lamps where the filament zigzags between two spiders supported at the top and bottom of a glass rod. Such lamps may produce high-frequency radio signals, which, when they fall within the frequency of a television channel, may cause interference up to a distance of 300 m. This appears as a stable horizontal bar across the screen.
- Defective thermostats in heating pads, sun lamps, furnace controls, electric razors, computers, fans, sewing machines, electric toys, video games, flashing fluorescent lights, commutator motors in vacuum cleaners, and light dimmers are common household sources of interference.

This type of interference can be remedied either by replacing the affected equipment or by applying interference suppressors at the terminals of the apparatus causing the interference (see Figure 2.1).

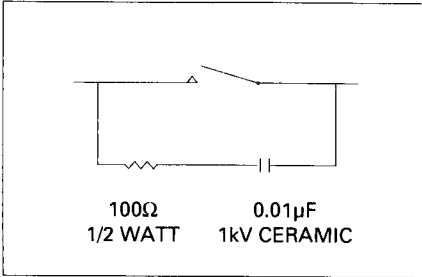

Figure 2.1 Spark eliminator circuit

### Power-line distribution systems

Faulty insulators, circuit breakers, transformers, lightning arrestors, clamps, and loose connections can interfere with radio and television reception. If the suspected source of the interference is an electric power line, contact the power utility in your area.

#### Note

*Steps for determining the source of the interference can be found in the booklet Radio and Television Interference, published by Communications Canada.*

### Thermostats

Since the contacts in heating system thermostats open and close frequently, and because they switch high-power current, they can easily form deposits or become corroded. Thus, thermostats should be replaced as needed, and 0.01 microfarad, 600 V capacitors should be installed between each contact as shown in Figure 2.2.

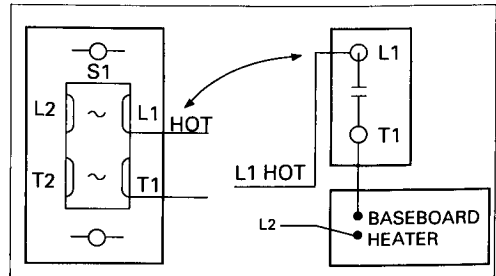

Figure 2.2 Installation of a capacitor in a typical thermostat

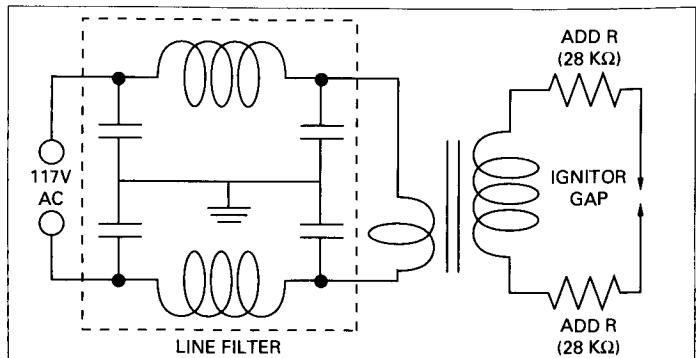

Figure 2.3 Suppression of interference originating in the firing systems of most modern oil or gas furnaces

## Lamp dimmers

The thyristor of a lamp dimmer switch produces strong radio-frequency interference. Recent dimmer models are housed in a metal box and are equipped with an internal filter system that reduces radio-electric interference. Interference caused by older lamp dimmers can be eliminated by connecting ceramic disk capacitors to the input and output terminals (see Figure 2.4).

the sound and horizontal bars and tearing in the picture of the affected device. In order to solve this problem, a capacitor or line filter can be added to the appliance. In cases of excessive interference, it may be necessary to replace the ballast, the fluorescent tubes, or both.

Many types of fluorescent lamps and ballast systems are currently in use. With all of them, radio-electric

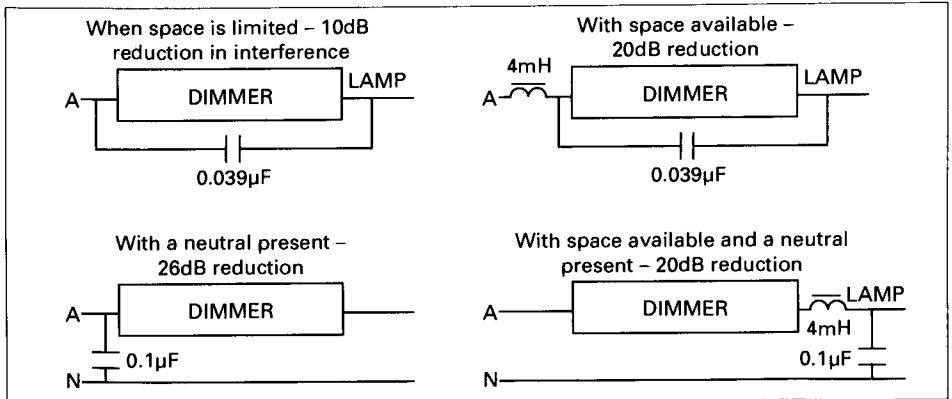

Figure 2.4 Four possible locations for suppressing interference from a light dimmer

## Fluorescent lights

In the case of 60-Hz fluorescent systems, ionization and extinction of the gas column takes place 120 times per second. These transient voltages produce wide-band radiation in the lamp and feedback emissions on the power line that can cause an intermittent hum in

noise can be reduced by connecting a capacitor in parallel between each of the power wires and the lamp ground (Figure 2.5). The lamp should be placed some distance from the radio receiver in order to minimize the possibility of picking up direct noise.

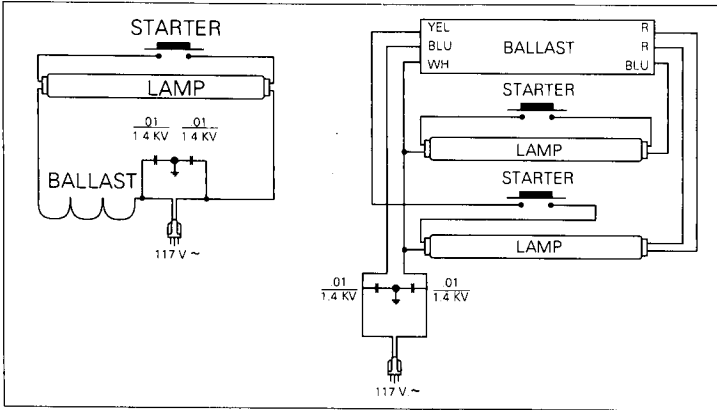

Figure 2.5 Installation of capacitors in fluorescent lighting

several kilometres, characterized by a sharp clicking from the affected device. This type of interference can be suppressed by installing a 10 kohm resistor in series with each high-voltage wire and connecting a line filter to the transformer (see Figure 2.6).

### Neon lamp

Neon lamps are similar to fluorescent lamps in that they produce a long arc inside the tube in order to excite the gas. However, neon lamps use step-up transformers to provide the high voltages necessary to excite the gas. The gas is ionized during the whole cycle, producing continuous, rather than transient wide-band, radiation.

Interference from a neon sign is partly caused by the high-voltage sparks produced by metallic objects near the sign and by loose electrical connections in the sign. The main source of interference, however, is loss of gas pressure in the lamp, which produces flickering. Any sporadic ionization of the neon will also produce interference within a radius of

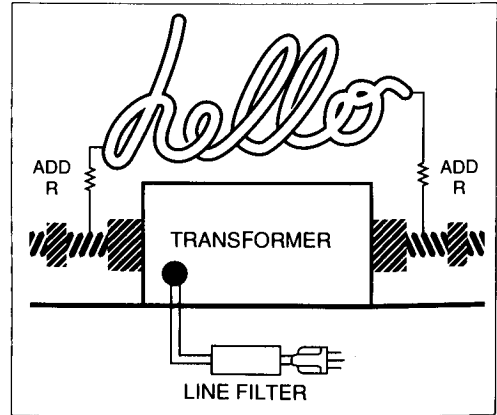

Figure 2.6 Installation of a line filter in the transformer of a neon light and 10 kohm resistors in series with each high-voltage wire

### Electric razors, knives, mixers, hair dryers

Most household appliances use compact commutator motors that can cause interference. Since these appliances are normally operated for relatively short periods, it is generally impractical to modify them.

Nevertheless, if an environment free of all RF interference is desired, it is possible to eliminate the interference by connecting a by-pass capacitor between each brush and the motor chassis, or between the two brushes (see Figures 2.7 and 2.8). If there is no motor chassis, which is the case with most small appliances, a line filter can be connected to the motor terminals. A plug-in line filter can also be used.

### Sewing machines

Most newer sewing machines are designed not to produce RF interference. If a sewing machine does produce interference, the first step in eliminating the problem is to connect a 0.05 microfarad, 600 V capacitor to the terminals

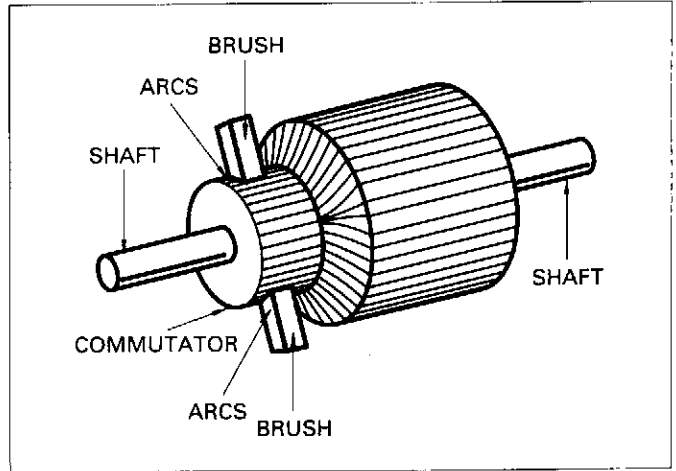

Figure 2.7 Side view of a typical armature; arcs (sparks) are produced between the commutator and each brush

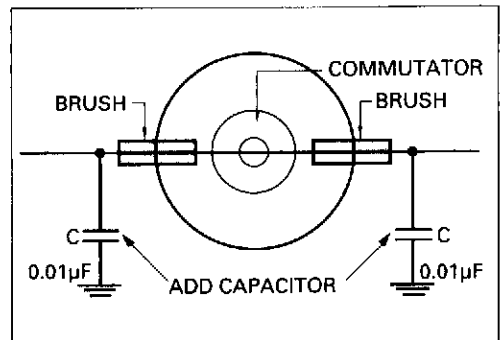

Figure 2.8 End view of a motor armature, showing location of capacitors

of the rheostat that regulates the speed of the motor. If there is enough space, a by-pass capacitor can also be installed between each brush and the chassis inside the motor. If there is not enough space, a line filter can be installed as close as possible to the body of the motor (see Figure 2.9).

produce large sparks that can be picked up as interference by a radio or television. The first step in eliminating this interference is to check the commutator and the brushes, and then to clean or replace them, as necessary. In addition, there may be enough space inside the appliance to connect

0.01 microfarad capacitors to the brushes. If there is not enough space, a line filter can be installed (see Figure 1.3).

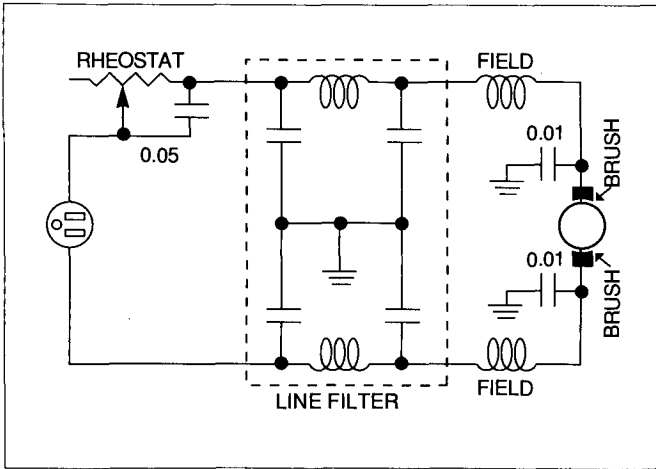

Figure 2.9 Suppression of interference originating in a sewing machine

### Vacuum cleaners

Most modern vacuum cleaners do not generate RF interference. Nevertheless, the inside of the motor may clog when the dust bag fails to trap all particles. This may



## ANALYZING THE INTERFERENCE

### Symptoms

**Audio:** intermittent harsh buzz

**Video:** horizontal bars or tearing

**Audio:** intermittent crackling or buzz

**Video:** horizontal bars

**Audio:** intermittent hum

**Video:** horizontal bars and tearing

### Possible interference sources

**Thermostats** - heating pads, electric blankets, ovens, hot-water heaters, aquarium warmers, refrigerator butter conditioners, heaters for linotype lead.

**Switches and contacts** - relays, sign flashers, starters for fluorescent lamps, light blinkers, doorbells, electric chimes, electric fly catchers.

**Ignition systems** - internal combustion engines, igniters for oil furnaces or heaters.

**Electrostatic devices** - smoke precipitators, dust collectors (those used in flour mills), static from machinery, belt static, antifriction bearings, printing press static eliminators; electrically operated devices such as adding machines, calculators or cash registers.

**Lights** - fluorescent, neon, mercury vapour or arc lights and some incandescent lamps.

**Audio:** intermittent or continuous "frying" sound

**Video:** two intermittent or continuous horizontal bars moving slowly from bottom to top

**Audio:** intermittent heavy crackling

**Video:** multiple thin black or white horizontal bars

**Power-line distribution systems** - faulty insulators, circuit breakers, transformers, lightning arrestors, clamps, loose connections.

**Electric motors** - motorized electrical appliances, such as electric razors, refrigerators, vacuum cleaners, water pumps, fans, sewing machines, drills, food/drink mixers, and toys (e.g., electric trains and cars).

### General information

The proposed circuits and suppressors discussed in chapters 1 and 2 are intended only as a guide for suppressing common interference problems. The following general information also applies when investigating any of these problems.

- 1 Outside television and radio antennas, instead of rabbit ears, help reduce coupling between the antenna and household electrical circuits and provide maximum signal pickup.
- 2 The strength of the signal being received in relation to the strength of the interfering signal determines the degree of interference picked up by a radio or television. It is not always possible to eliminate totally all interference.
- 3 The safest, most practical solution to interference caused by a defective thermostat in an electric pad or blanket is to replace the pad or blanket with a model that has a non-interfering thermostat.

### 3 Television interference from radio transmitters

In licensing radio communication stations, Communications Canada strives to assign frequencies that will not interfere with television reception. Occasionally, however, through faulty equipment or design, radio transmitters may radiate excessive harmonics. Harmonic radiations are multiples of the operating frequency. If these harmonics fall on a television channel, they will cause interference. Such harmonics must be reduced to a reasonable level at the transmitter (see Figure 3.1), so they do not interfere with television reception.

In general, commercial transmitting equipment that is type-approved by Communications Canada is built to reduce harmonic radiation. Nevertheless, if television interference occurs, the channels affected should be noted (see Figure 3.2) and the steps outlined here should be followed to ensure that the radio equipment is operating properly.

#### Checking the radio transmitter

Before modifying or adjusting a radio installation, check its technical performance to ensure that it meets the technical characteristics listed by the manufacturer, or the standards established by Communications Canada for that type and category of device.

#### Transmitter harmonics

If the interference seems to be caused by harmonic radiation, use either a spectrum analyzer, a calibrated field intensity meter, or a frequency-selective voltmeter to accurately measure any harmonic and spurious radiation from the transmitter (see Figure 3.3).

If any lead-in device, such as a standing wave ratio (SWR) meter, is part of the transmitter set-up, these measurements should be taken with that device both installed and removed. This may help identify the source of the interference (see Figure 3.4).

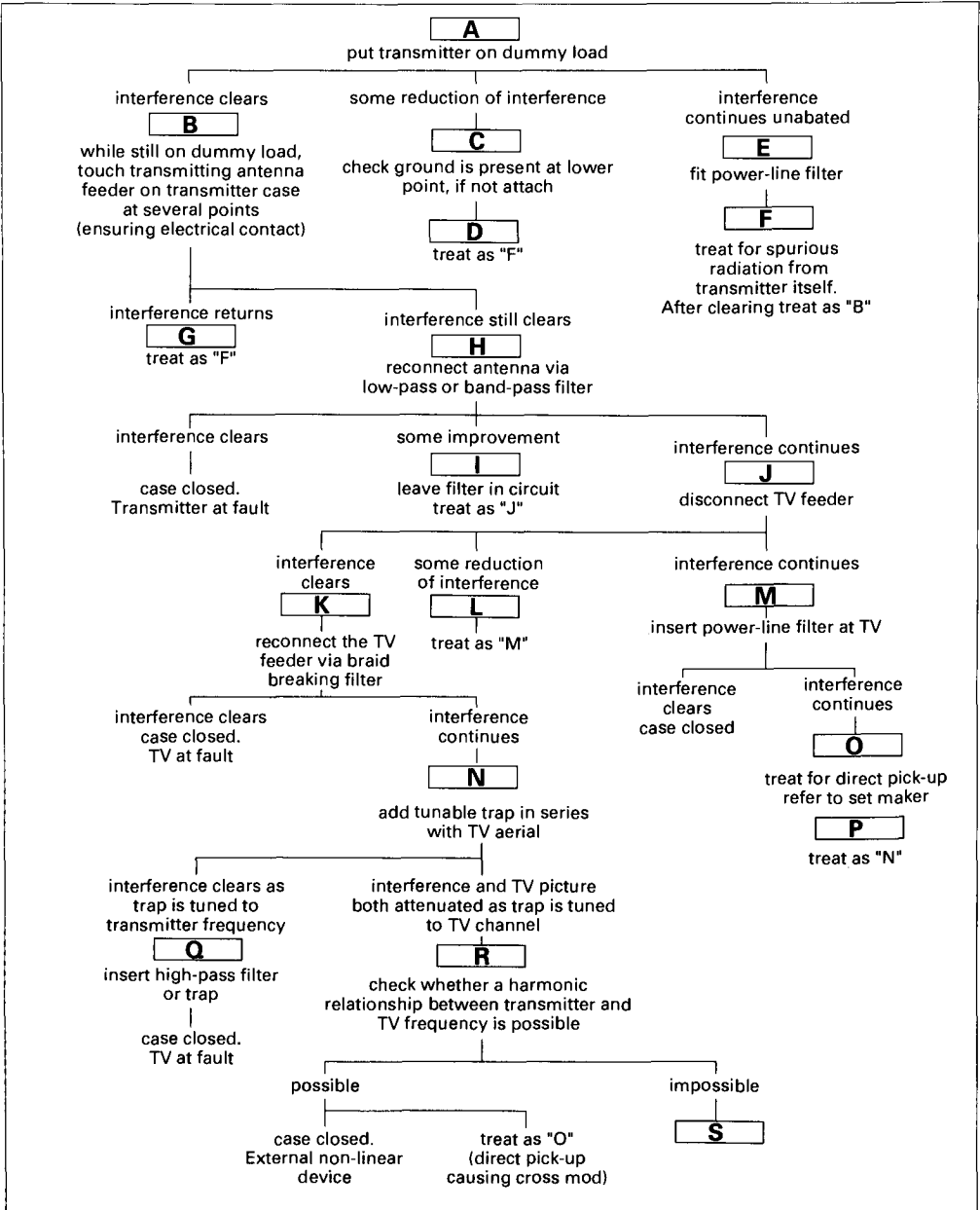

Figure 3.1 Guide for locating transmitter interference

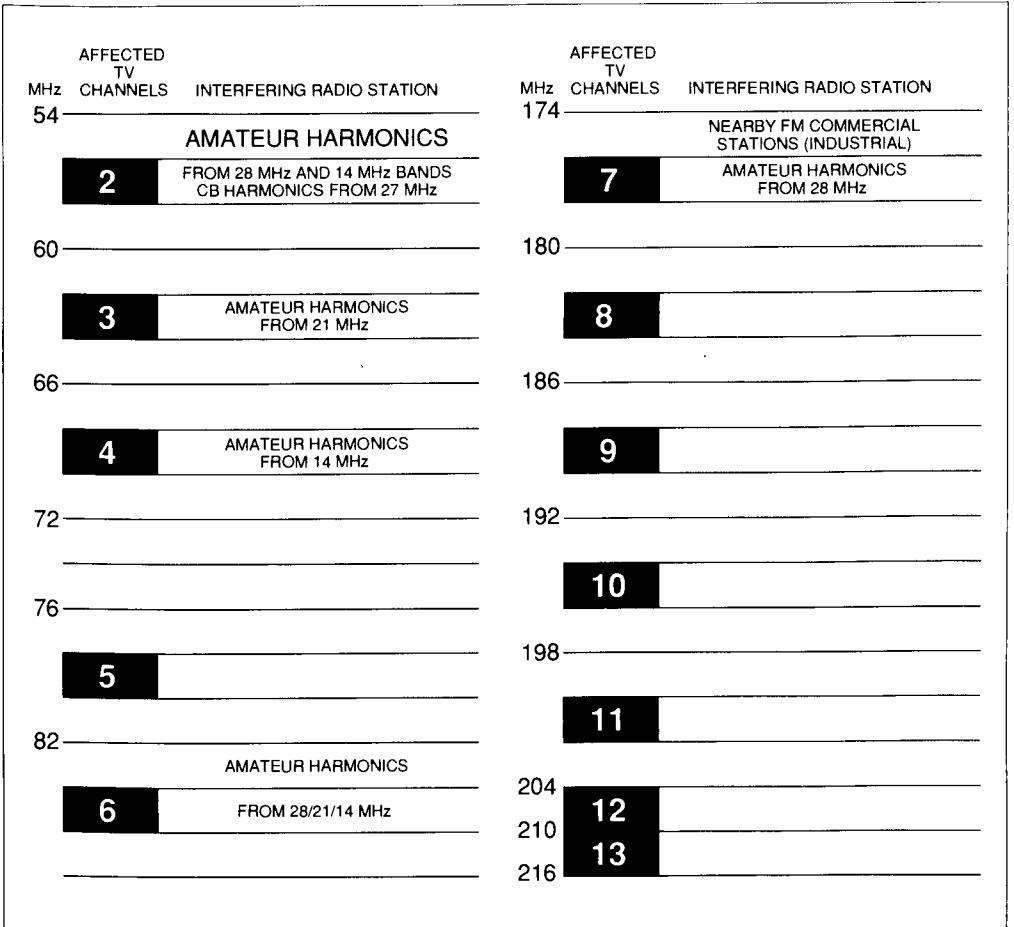

Figure 3.2 Relationship between VHF television channels and radio stations that might produce interference

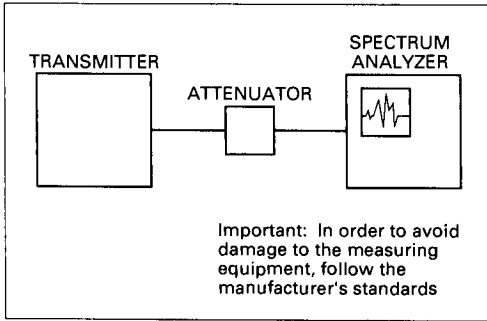

Figure 3.3 Spectrum analyzer measuring harmonic radiation

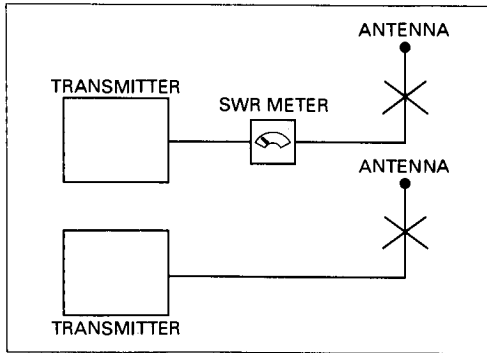

Figure 3.4 Standing wave ratio (SWR) meter measuring harmonic radiation

### Grounding

If it appears that the transmitter is at fault, it will first be necessary to ensure that the transmitter is grounded to a good earth ground (metal cold water pipe or 2.5 m [8 ft] ground rod). A solid conductor wire of at least no. 10 gauge or copper ribbon should be used as a ground lead. The lead should be as

short as possible (see Figure 3.5). In addition, to ensure a proper ground, make certain the screws holding the chassis of the set to its metal case are tightened securely.

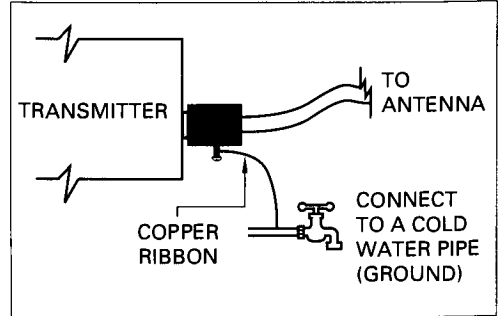

Figure 3.5 Ensuring a proper ground

### Power-line filter

Some transmitters may radiate harmonic and spurious energy from their cabinet or through the power lines. In these cases, an attempt should be made to operate the transmitter with a shielded dummy load (see Figure 3.6). If interference is still present, the source of the radiation will probably be the cabinet or the line. A power-line filter should be installed to remedy the situation. Several types of power-line filters are commercially available. For low-power transmitters, the filter shown in Schematic 2 of Figure 1.4 may be used.

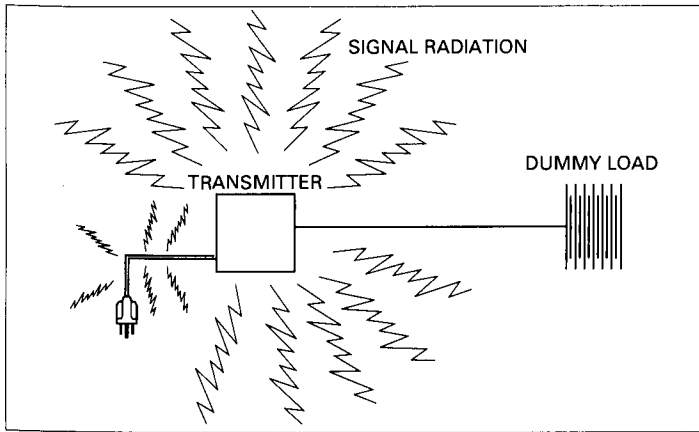

Figure 3.6 Operating a transmitter with a shielded dummy load

Installing one or more low-pass filters in the transmitter antenna lead will reduce the incidence of unnecessary harmonic radiation (see Figure 3.7). Depending on the brand, a low-pass filter allows frequencies of up to 30 or 50 MHz to pass through unattenuated to the antenna, while blocking much of the harmonic radiation.

### Transmission filtering

Next, a low-pass filter should be installed on the transmitter antenna circuit to determine whether it affects the interference pattern. If it does, the interference is probably caused by harmonics or spurious emissions from the transmitter. If no change occurs, the interference is probably being generated at some point in the television reception system.

### Checking the television antenna system

A visual inspection of the television antenna, lead-in wire, and lightning arrestors may reveal the source of interference. For example, corroded connections or a deteriorated lead-in wire can cause interference and should be repaired.

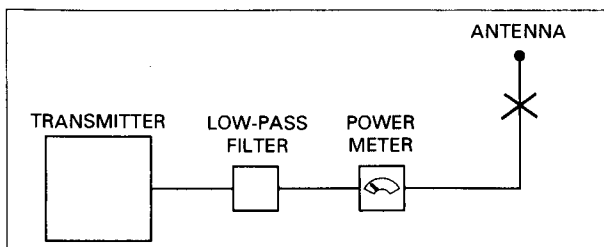

Figure 3.7 Installation of a low-pass filter in an antenna lead

If no faulty conditions are found, or faults are corrected, and the interference persists, check for an amplifier in the circuit. Amplifiers are highly sensitive to RF radiation.

**Note**

Television booster amplifiers are usually located near the back of the television set. Mast-mounted (outdoor) amplifiers are usually located near the antenna; distribution amplifiers are usually located in the distribution system. If there is a distribution amplifier in the antenna system, trace the entire length of the antenna system since amplifiers are usually in out-of-the-way places such as clothes closets and basements.

If there is an amplifier in the system, disconnect it. If this eliminates the interference, then the amplifier can be reconnected; however, it will need to be protected by one of the following means: grounding it directly, enclosing it in a metallic RF-proof housing and grounding the housing, or by installing a high-pass filter at the input to the amplifier. If one filter improves the reception but does not entirely eliminate the interference, install two filters in series (see Figure 3.8).

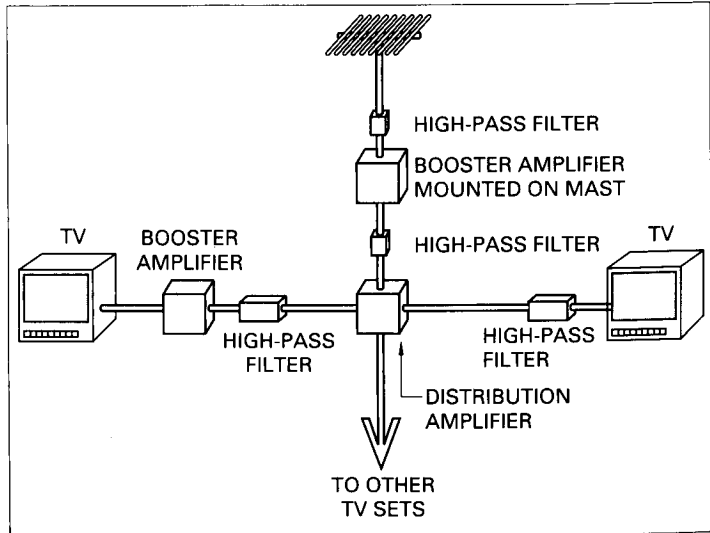

Figure 3.8 Installation of high-pass filters in antenna systems

If there is no amplifier in the circuit, or if the interference persists after following the above steps, check the television receiver.

**Checking the television receiver**

As a first step, disconnect the antenna. If the interference persists try installing a power-line filter. If no change is found, then the set itself must be responding to the RF radiation.

The tuner is the most likely internal circuit in the set to be affected by a radio transmitter. Thus, the antenna input lead



inside the set directly at the tuner should be disconnected. If this eliminates the interference, a high-pass filter should be installed at this level (see Figure 3.9).

### Elimination methods

Several types of high-pass and low-pass filters are commercially available (see Figure 3.11). Specialized electronics and communications manuals also offer design suggestions for making devices and filters that can be used to eliminate some types of interference.

#### Quarter-wave stub (circuit eliminator)

A piece of transmission line of a length equal to one quarter of the wavelength of a given frequency propagated along a line of the same construction displays what might at first seem surprising characteristics. If one end is shorted, the other end presents an open circuit to voltages at that frequency, and if the end is opened, it presents a short to voltages at

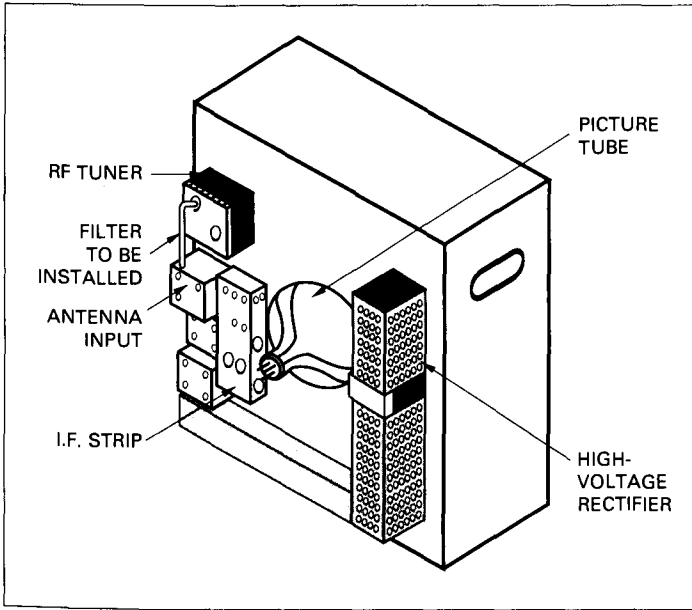

Figure 3.9 Installation of a high-pass filter in a television

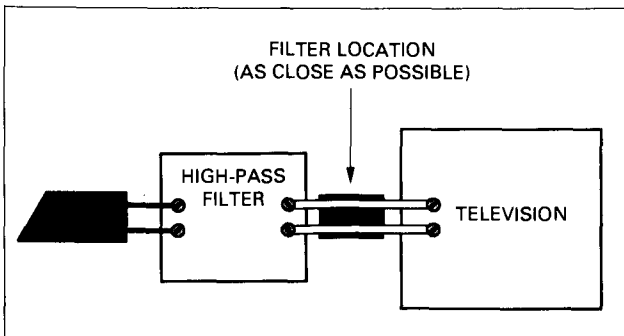

Figure 3.10 Installation of a high-pass filter at television antenna inputs

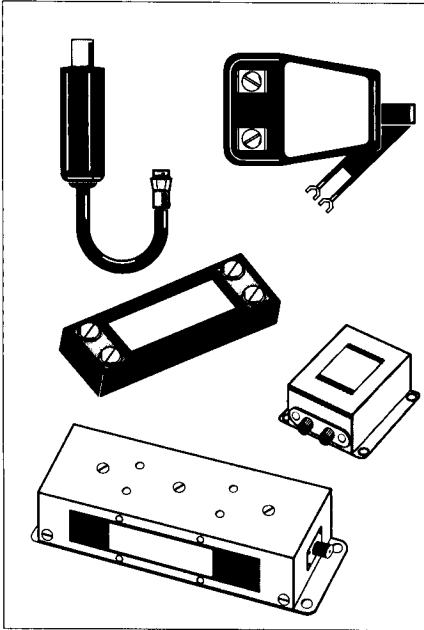

Figure 3.11 Various high-pass and low-pass filters

that frequency. This property is frequency-selective and can be used to eliminate an interfering signal from a television receiver by shorting it out. Such short lengths of transmission line used as filters are called stubs (see Figure 3.12).

In the case of General Radio Service (Citizens Band) interference with television channel 2, the stub should be made of the same type of wire as the antenna input terminals on the television set. The initial stub length should be 94 cm (37 in.) for RG-59/U coaxial cable; and 122 cm (48 in.) for 300 ohm twin-lead cable.

After connecting the stub (see Figure 3.12), the unterminated end of the stub should be cut off

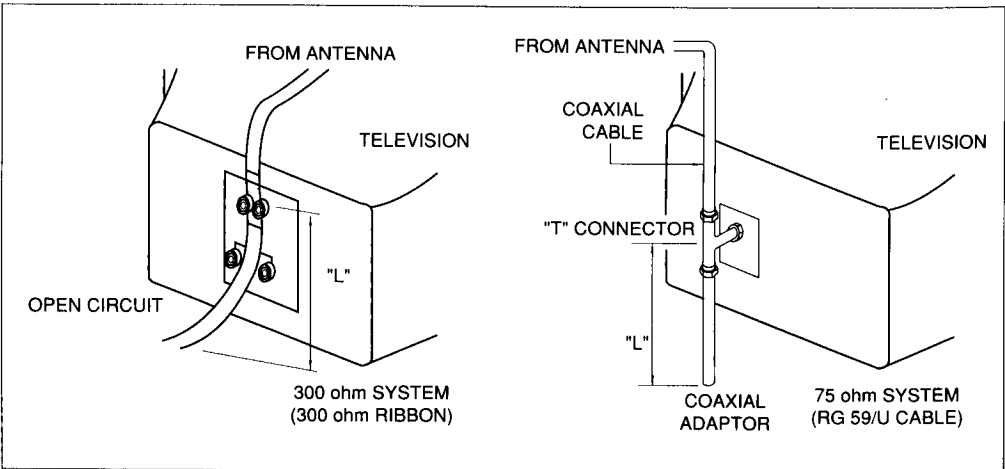

Figure 3.12 Use of quarter-wave stubs to eliminate interference

in 0.32 cm (1/8 in.) to 0.64 cm (1/4 in.) sections until the interference is eliminated. For harmonics interfering with other television channels, such as channels 5, 6, or 9, the length of the stub may be reduced in accordance with the following formula:

$$\text{Length (L) in centimetres} = \frac{7.500 \times V}{f}$$

where:

V = velocity factor of the line; and  
f = frequency in MHz.

In the case of amateur radio interference to channel 2, if RG-59/U coaxial cable is used as the television lead-in wire, the initial length of the stub should be 107 cm (42 in.). If 300 twin-lead cable is used, the initial length should be 135 cm (53 in.). After the stub is attached to the television set, the unterminated end of the stub should be cut off in 0.32 cm (1/8 in.) to 0.64 cm (1/4 in.) sections until the interference is eliminated. If the interference is reduced but not eliminated by this method, a second stub should be added directly to the input terminals of the tuner.

The theoretical final length of the stub should be:

$$\text{Length (L) in centimetres} = \frac{7.500 \times V}{f}$$

where:

V = velocity factor of the line; and  
f = frequency in MHz.

In the case of interference from an FM radio station, the initial length of the stub should be 61 cm (24 in.) for RG-59/U coaxial cable, or 74 cm (29 in.) for 300 twin-lead wire. For other cables, the initial length can be determined with the following formula:

$$\text{Length (L) in centimetres} = \frac{89 \times V}{f}$$

where:

V = velocity factor of the line; and  
f = frequency in MHz.

**Note**

*The velocity factor of the line may be obtained from the cable manufacturer.*

**Quarter-wave tuned stubs**

Quarter-wave tuned stubs have an open circuit at one end and the other end is connected to the masthead amplifier, the distribution amplifier, or the television

receiver antenna terminals. The stub establishes a series-resonant circuit that causes a short-circuit at the frequency for which the stub is cut.

### Half-wave tuned stub

Half-wave tuned stubs reflect a short circuit back to the other end of the line at the frequency for which the stub is cut. The stub should be made of the same type of cable as the cable to which it attaches.

The formulas for stub lengths (L) in centimetres are:

$$\text{Quarter-wave } L = \frac{7\,500 \times V}{f}$$

$$\text{Half-wave } L = \frac{15\,000 \times V}{f}$$

where:

V = velocity factor of the transmission line; and

f = frequency in MHz.

### Note

*For 300 ohm, twin feeder V = 0.83.*

*For 75 ohm, coaxial feeder (RG-59/U)*

*V = 0.66.*

### Tunable stub trap

A tunable stub trap can be made from 300 ohm balanced feeder or 75 ohm coaxial cable. Details for making tunable stubs for 300 ohm feeder are as follows:

The feeder should have a ceramic trimmer at one end while the other end is shorted (a 10 kohm resistor may be substituted to make the stub broadband). The stub is initially taped to another length of 300 ohm feeder, and the required frequency is then applied to the cable with the measuring instrument at the other end. The ceramic trimmer is then adjusted until maximum attenuation at the desired frequency is obtained.

Place the trap on and parallel to the lead-in wire and tune for minimum interference. Then slide the trap along the line until the interference is further reduced. Finally, tape the trap to the lead-in wire in the most effective position (see Figure 3.13).

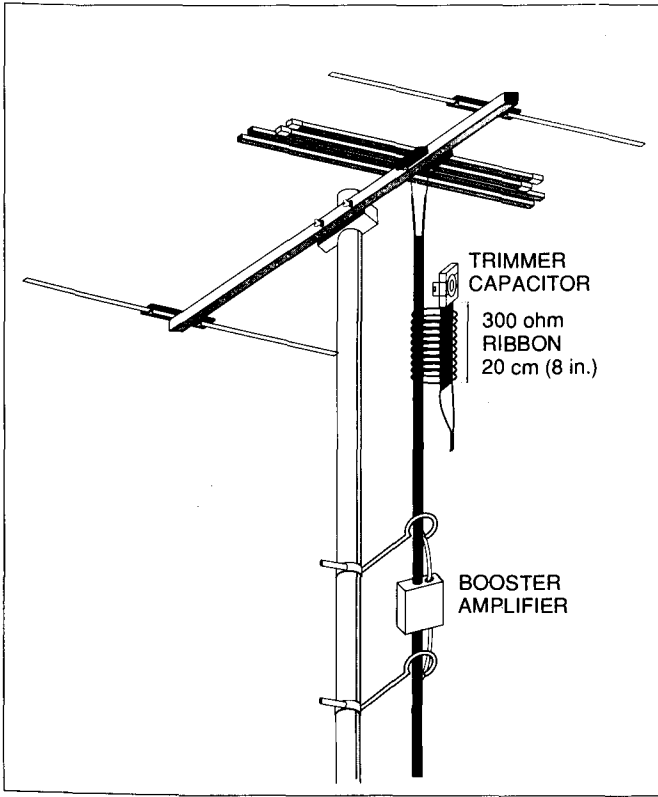

Figure 3.13 Installation of a tunable stub trap by taping it to the 300 ohm antenna ribbon

## 4 Factors affecting reception

### Modes of propagation

Radio and television signals may be propagated from a transmitting antenna to a receiving antenna in various ways: following the curvature of the earth, through the atmosphere, or by reflection from natural or artificial reflectors. Reception conditions can vary considerably depending on location and time. Outside the primary service area the intensity of the received signal is likely to vary with time. This variation may be rapid, for instance at distances of 130 km or more the received signal may fade and return to strength within a few minutes. There is likely to be random variation in the field strength from day to day and from season to season.

### Receiver installation

Satisfactory television reception requires adequate signal voltage at the receiver input terminals and a suitable antenna with a height, location and orientation that will enable the antenna to pick up the transmission signal without undue noise.

As a general rule, increasing the height of the receiving antenna considerably improves reception for distances greater than 30 km from the television broadcast station. There are exceptions to this rule. When possible therefore, tests should be performed to determine the best height, location, and orientation for the antenna. For instance, moving an antenna a few metres, particularly in cities, may improve considerably the television signal voltage delivered to the receiver.

### Mast

As a general rule, the height of the antenna affects its operational efficiency. To obtain an effective height, antennas can be mounted on a mast consisting of 1.5 m to 3 m lengths of galvanized steel or aluminum pipe joined together to a maximum height, for safety, of 15 m. For higher antennas, it is preferable to erect a tower. Telescopic masts, measuring 6 m to 10 m, are also available.

Although steel is stronger, aluminum pipe is sufficient to support a light antenna up to a height of 3 m. In areas exposed to strong winds, it is preferable to use only steel. The required thickness of the pipe will vary depending on the weight of the antenna.

## Ground rod

The antenna mast installation should also include a connection to an iron, copper, or aluminum rod (ground rod) sunk into the ground. This will carry any electrical discharge striking the antenna into the ground. Lightning protection is particularly important for high antennas and those in isolated locations. For additional protection, the base of the mast should be solidly anchored in the ground with high-gauge cable. It is important to follow installation instructions carefully (see Figure 4.1).

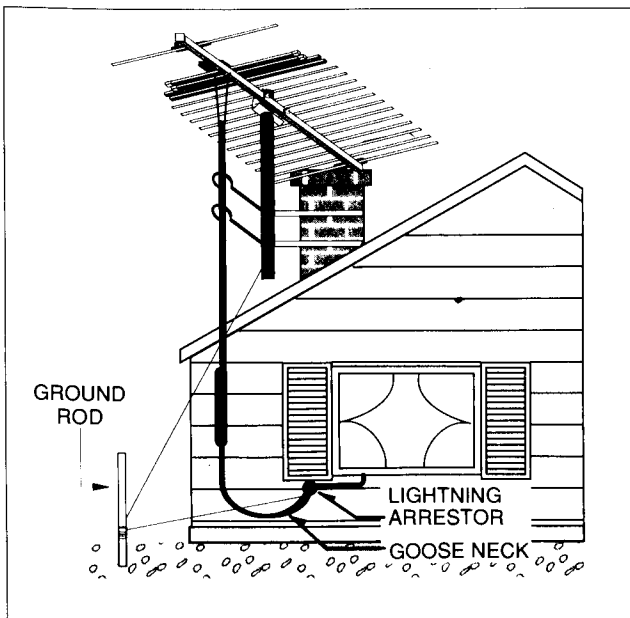

Figure 4.1 Antenna installation with lightning rod

## Antenna down-lead

It is essential to have a good conductor between the antenna and the television set. Twin-lead wire is generally used. In some areas, it may be necessary to use insulated cable or coaxial cable to minimize interference.

## Pre-amplifier

In order to improve the quality of the image, small inexpensive pre-amplifiers may be installed on the antenna to amplify the received signal. The impedance of such an amplifier must be the same as that of the antenna down-lead. When using an insulated down-lead, stand-off insulators should be used to prevent the cable contacting metal objects such as roofs, pipes, or eaves-troughs. The first stand-off should be installed as close to the antenna terminal as possible.

## Lead-in wire

The twin-lead wire should be twisted one turn for every metre of length to help prevent excessive movement in

the wind and to minimize interference. The lead-in wire, however, should not be twisted too tightly or it may break.

The lead-in wire, the terminals, and the stand-off insulators or lightning arrestor should never be painted, as this will decrease the efficiency of the antenna system.

Never splice the lead-in wire, not even with solder, as this will weaken the signal reaching the television set. It is therefore preferable to buy a length of wire that is longer than necessary and then cut the excess once the installation is complete.

**Note**

*Excess wire coiling behind the television set may create ghosting in the picture or signal loss.*

Ensure that the lead-in wire is securely attached to the input terminals at the antenna and the receiver. Antennas for channels 2 to 13 should be connected to the VHF terminals, and antennas for channels 14 to 83 should be connected to the UHF terminals (see Figure 4.2). To prevent the two wires from touching, attach each wire using a U-shaped metal clip.

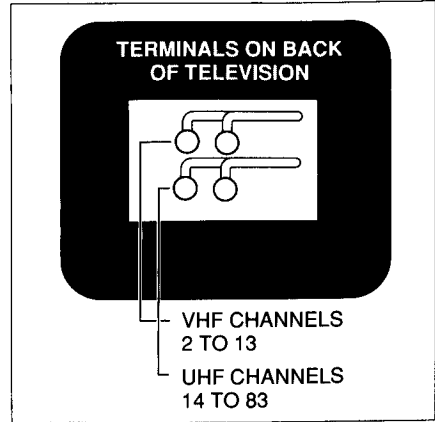

Figure 4.2 Installation of antenna lead-in wire

**Note**

*Improper connections, broken wires, and corrosion decrease signal quality.*

## The antenna

### Dipole antenna

The simplest outdoor antenna is the dipole antenna. It consists of two conductors of equal length made of aluminum pipe. Intended for VHF reception, the dipole antenna is only satisfactory within a maximum range of 30 km from the transmitter channel for which it has been designed. In cases where a dipole antenna is used and there is a signal on the same or an adjacent channel coming from the opposite direction, there may be a lot of interference on the television screen: grid patterns,



diagonal lines, wavy lines. If this occurs, a directional antenna will be required to capture the signals in front and reject those coming from the sides or back.

**Single-channel directional antenna**

The simplest directional antenna is called a yagi and consists of several symmetrical straight elements (metal rods) arranged horizontally. It provides the best results for receiving a single VHF channel.

**Multiple-channel directional antenna**

The multiple-channel directional (high-gain yagi) antenna consists of elements that increase in length from one end to the other. This antenna is recommended for receiving several VHF channels. Some of these antennas also allow reception on the UHF and FM bands.

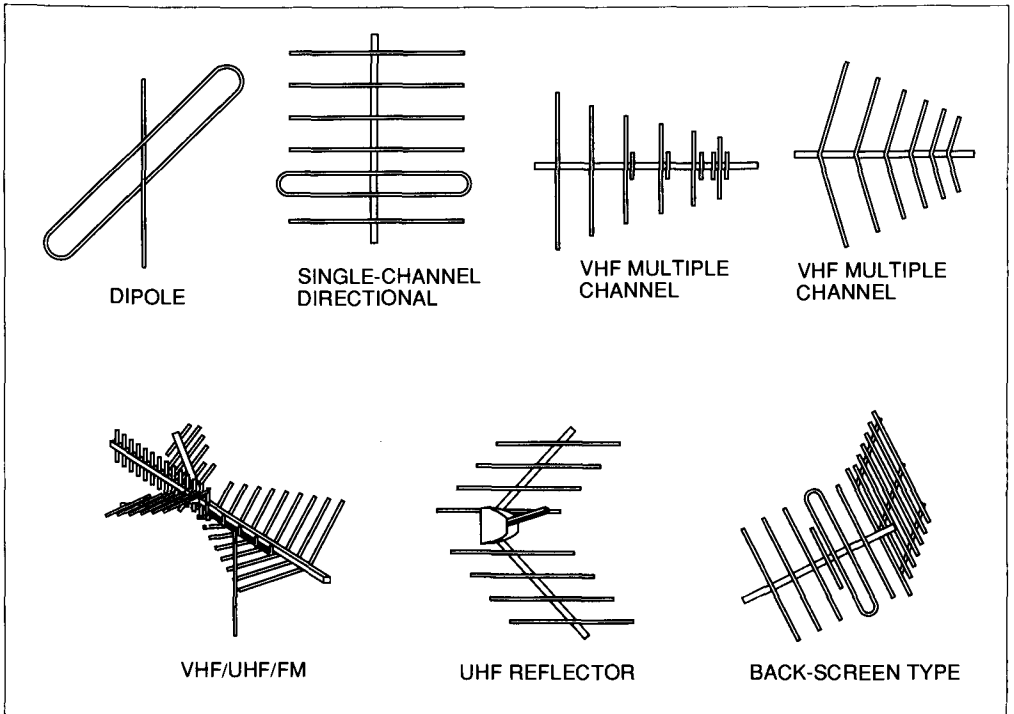

Figure 4.3 Different types of antennas

A high-gain yagi antenna is adequate when there are only two television transmitting stations in the region coming from more or less the same direction in relation to the television set, and when the channels are close together, for example 2 and 4.

### Note

*The frequencies for channels 6 and 7, and 13 and 14, are not close together. (See Appendix 4.)*

On the other hand, if the two stations are in opposite directions, or the channels are far apart, for example 2 and 8, it may be necessary to have a directional antenna for each channel, or one directional antenna for multiple channels that can be aimed by a remote-control rotor to receive multiple channels. A rotor allows the user to watch the television set while turning the antenna to find the direction that provides the best image.

### **Antenna for UHF channels (14 to 83)**

All newer television sets come equipped with a VHF tuner for channels 2 to 13 and a UHF tuner for channels 14 to 83.

To receive any local UHF station, it may be necessary to install a UHF antenna, unless a multiple-channel directional antenna good for UHF reception is already being used. Indoor loop UHF antennas are available, but they are only satisfactory when used near the transmitting station. There are several types of outdoor UHF antennas: loop antennas, corner reflector antennas, and parabolic reflector antennas. These are all directional antennas and only capture signals coming from a single direction. UHF antennas should be connected to the UHF terminal of the television set.

## **Reception difficulties**

### **Reflections**

Buildings and hills can reflect television signals, causing ghost images to appear on the television screen. These images occur because the broadcast signal and the reflected signal arrive at the receiver at slightly different times. The result is a double image on the television. The reflecting surface causing the ghost may be at any location within 360 degrees of the receiving antenna (see Figure 4.4).

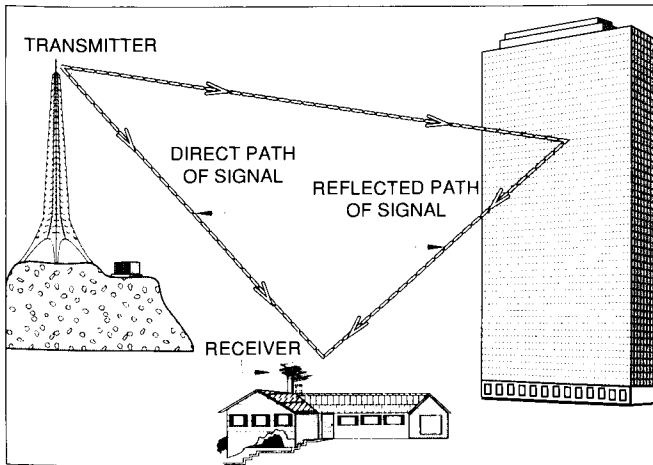

Figure 4.4 Reflection of television signal

Occasionally the reflected signal is much stronger than the direct signal. In that situation, the direct one can be ignored and the antenna oriented to receive the reflected signal. If the reflection is from behind the television antenna, a yagi with a high front-to-back ratio or a back-screen antenna may remove or reduce the ghost image.

Reflections may also be caused by faulty antenna installations. A mismatch in the characteristic impedance of the feeder cable or antenna can result in standing wave reflections on the feeder line.

### Adjacent channel interference

Adjacent channel interference occurs when a strong television signal from a channel next to the one being viewed is not sufficiently attenuated by the adjacent channel traps within the receiver.

This interference can sometimes be overcome by installing a directional antenna or a yagi that has a back screen. In a situation where the signal for the adjacent channel comes from the same

direction as the desired channel, there is no benefit obtained by improving the front-to-back ratio of the antenna.

The most common remedy in overcoming this problem is to fit an adjacent channel trap. These traps are normally sharply tuned, high-Q networks inserted in the antenna lead. In extreme cases, where adjacent channel interference is present from both sides of the desired channel, two adjacent channel traps can be used in a series configuration, one for the lower adjacent channel and one for the upper adjacent channel (see Figure 4.5).

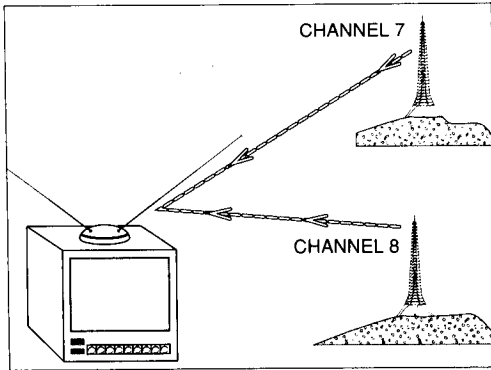

Figure 4.5 Adjacent channel interference

### Co-channel interference

Co-channel interference occurs when the receiver responds to two stations that are on the same frequency or slightly offset from each other (see Figure 4.6). Because the stations are geographically separated from each other, usually no interference occurs.

During the summer, however, interference from the more distant television station can occur because of propagation peculiarities.

This type of interference mainly occurs on lower-frequency television channels. It appears either as horizontal bars, often referred to as venetian blinds, or as a faint background image. Also, the synchronizing pulses can sometimes be noticed moving slowly in the background.

Co-channel interference is more common in fringe reception areas, for example, between urban and rural areas or between cities. The degree of interference depends on the ratio between the received signal strengths of the two stations. On some occasions the distant

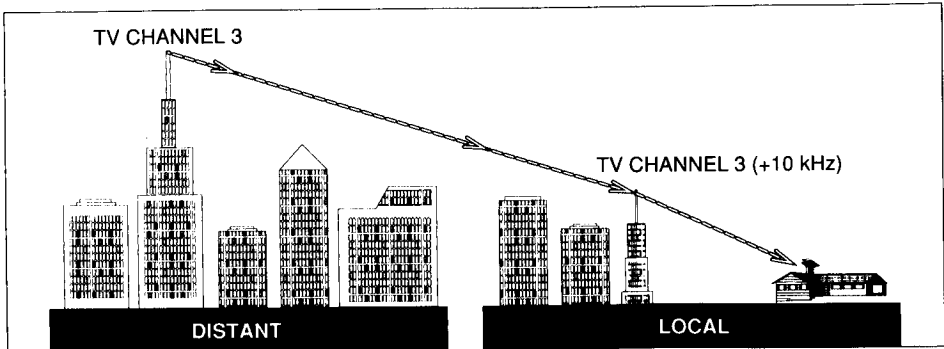

Figure 4.6 Co-channel interference

station may have the greater signal level for a short period, resulting in its program becoming predominant.

If the desired signal is sufficiently strong, the interference may be overcome with a directional antenna oriented to avoid reception from the undesired station.

### **Low signal conditions**

Low-level signals at the television receiver result in speckles or coloured confetti, called "snow," across the screen. To eliminate this snow, the input signal to the receiver must be increased to produce a higher signal-to-noise ratio. The following methods may increase this ratio:

- Replace the existing antenna with a higher-gain antenna.
- Use a separate antenna for low and high bands.
- Increase the antenna height.
- Replace the antenna feeder cable if it is in poor condition.

- Reduce the length of antenna feeder cable as much as possible.
- Fit a masthead amplifier to the television antenna.



## Appendices

### Appendix 1 Hertzian wave spectrum

<b>Frequency</b>	<b>Wavelength</b>	<b>Metric designation</b>	<b>Current designation</b>	<b>International abbreviation</b>
10 kHz to 30 kHz	30 km to 10 km	myriametric waves	very low frequencies	VLF
30 kHz to 300 kHz	10 km to 1 km	kilometric waves	low frequencies	LF
300 kHz to 3 MHz	1 km to 100 m	hectometric waves	medium frequencies	MF
3 MHz to 30 MHz	100 m to 10 m	decametric waves	high frequencies	HF
30 MHz to 300 MHz	10 m to 1 m	metric waves	very high frequencies	VHF
300 MHz to 3 GHz	1 m to 10 cm	decimetric waves	ultra high frequencies	UHF
3 GHz to 30 GHz	10 cm to 1 cm	centimetric waves	super high frequencies	SHF
30 GHz to 300 GHz	1 cm to 1 mm	millimetric waves	extremely high frequencies	EHF

## **Appendix 2**

### **Frequency allocations from 30 kHz to 300,000 MHz**

<b>Band</b>	<b>Allocation</b>
30-535 kHz	Includes maritime communications and navigation, international fixed public band, aeronautical radio navigation
535-1,605 kHz	Standard radio broadcast band AM broadcast
1,605 kHz-30 MHz	Includes amateur radio, loran, government radio, international short-wave broadcast, fixed and mobile communications, radio navigation, industrial, scientific, and medical equipment
30-50 MHz	Government and non-government, fixed and mobile
50-54 MHz	Amateur
54-72 MHz	Television broadcast channels 2-4
72-76 MHz	Government and non-government, fixed and mobile
76-88 MHz	Television broadcast channels 5 and 6
88-108 MHz	FM broadcast
108-122 MHz	Aeronautical navigation
122-174 MHz	Government and non-government, fixed and mobile, amateur broadcast
174-216 MHz	Television broadcast channels 7-13
216-470 MHz	Amateur broadcast, government and non-government, fixed and mobile, aeronautical navigation, citizens' radio
470-890 MHz	Television broadcasting
890-3,000 MHz	Aeronautical radionavigation, amateur broadcast, studio-transmitter relay, government and non-government, fixed and mobile
3,000-30,000 MHz	Government and non-government, fixed and mobile, amateur broadcast, radio navigation
30,000-300,000 MHz	Experimental, government, amateur



## Appendix 3 Radio frequencies

### General radio service frequencies (CB Radio)

26.965 MHz	27.085 MHz	27.215 MHz	27.315 MHz
26.975 MHz	27.105 MHz	27.225 MHz	27.325 MHz
26.985 MHz	27.115 MHz	27.235 MHz	27.335 MHz
27.005 MHz	27.125 MHz	27.245 MHz	27.345 MHz
27.015 MHz	27.135 MHz	27.255 MHz	27.355 MHz
27.025 MHz	27.155 MHz	27.265 MHz	27.365 MHz
27.035 MHz	27.165 MHz	27.275 MHz	27.375 MHz
27.055 MHz	27.175 MHz	27.285 MHz	27.385 MHz
27.065 MHz	27.185 MHz	27.295 MHz	27.395 MHz
27.075 MHz	27.205 MHz	27.305 MHz	27.405 MHz

### Amateur radio service frequencies

<i>Lower frequency limit</i>	<i>Higher frequency limit</i>
1.800 MHz	2.000 MHz
3.500 MHz	4.000 MHz
7.000 MHz	7.300 MHz
10.100 MHz	10.150 MHz
14.000 MHz	14.350 MHz
18.068 MHz	18.168 MHz
21.000 MHz	21.450 MHz
24.890 MHz	24.990 MHz
28.000 MHz	29.700 MHz
50.000 MHz	54.000 MHz
144.000 MHz	148.000 MHz
220.000 MHz	225.000 MHz
430.000 MHz	450.000 MHz
902.000 MHz	928.000 MHz
1 215.000 MHz	1 300.000 MHz
2 300.000 MHz	2 450.000 MHz
3 300.000 MHz	3 500.000 MHz
5 650.000 MHz	5 925.000 MHz
10 000.000 MHz	10 500.000 MHz
24 000.000 MHz	24 050.000 MHz
24 050.000 MHz	24 250.000 MHz

## Appendix 4 Television channel frequencies

Channel number	Frequency band MHz	Picture carrier frequency MHz	Sound carrier frequency MHz	Channel number	Frequency band MHz	Picture carrier frequency MHz	Sound carrier frequency MHz
2	54-60	55.25	59.75	36	602-608	603.25	607.75
3	60-66	61.25	65.75	37	608-614	609.25	613.75
4	66-72	67.25	71.25	38	614-620	615.25	619.75
5	76-82	77.25	81.75	39	620-626	621.25	625.75
6	82-88	83.25	87.75	40	626-632	627.25	631.75
7	174-180	175.25	179.75	41	632-638	633.25	637.75
8	180-186	181.25	185.75	42	638-644	639.25	643.75
9	186-192	187.25	191.75	43	644-650	645.25	649.75
10	192-198	193.25	197.75	44	650-656	651.25	655.75
11	198-204	199.25	203.75	45	656-662	657.25	661.75
12	204-210	205.25	209.75	46	662-668	663.25	667.75
13	210-216	211.25	215.75	47	668-674	669.25	673.75
14	470-476	471.25	475.75	48	674-680	675.25	679.75
15	476-482	477.25	481.75	49	680-686	681.25	685.75
16	482-488	483.25	487.75	50	686-692	687.25	691.75
17	488-494	489.25	493.75	51	692-698	693.25	697.75
18	494-500	495.25	499.75	52	698-704	699.25	703.75
19	500-506	501.25	505.75	53	704-710	705.25	709.75
20	506-512	507.25	511.75	54	710-716	711.25	715.75
21	512-518	513.25	517.75	55	716-722	717.25	721.75
22	518-524	519.25	523.75	56	722-728	723.25	727.75
23	524-530	525.25	529.75	57	728-734	729.25	733.75
24	530-536	531.25	535.75	58	734-740	735.25	739.75
25	536-542	537.25	541.75	59	740-746	741.25	745.75
26	542-548	543.25	547.75	60	746-752	747.25	751.75
27	548-554	549.25	553.75	61	752-758	753.25	757.75
28	554-560	555.25	559.75	62	758-764	759.25	763.75
29	560-566	561.25	565.75	63	764-770	765.25	769.75
30	566-572	567.25	571.75	64	770-776	771.25	775.75
31	572-578	573.25	577.75	65	776-782	777.25	781.75
32	578-584	579.25	583.75	66	782-788	783.25	787.75
33	584-590	585.25	589.75	67	788-794	789.25	793.75
34	590-596	591.25	595.75	68	794-800	795.25	799.75
35	596-602	597.25	601.75	69	800-806	801.25	805.75

