

Image Cover Sheet

CLASSIFICATION

SYSTEM NUMBER

68682

UNCLASSIFIED



TITLE

ADVANCES IN THE LOCATION AND IDENTIFICATION OF HIDDEN EXPLOSIVE
MUNITIONS

System Number:

Patron Number:

Requester:

Notes:

DSIS Use only:

Deliver to: JR



UNCLASSIFIED

DEFENCE RESEARCH ESTABLISHMENT SUFFIELD
RALSTON, ALBERTA

Suffield Report No. 548

ADVANCES IN THE LOCATION AND IDENTIFICATION
OF HIDDEN EXPLOSIVE MUNITIONS (U)

by

John E. McFee and Yogadhis Das

December 3, 1990

WARNING

The use of this information is permitted subject to recognition
of proprietary and patent rights.

UNCLASSIFIED

UNCLASSIFIED

EXECUTIVE SUMMARY

The Ordnance Detection Group (ODG) of the Defence Research Establishment Suffield (DRES) has been investigating the detection of buried ordnance, and buried and surface-laid land mines for a number of years. As a part of that program, they monitor and contribute to the current state-of-the-art in detection of explosive munitions. To aid in maintaining this knowledge base, ODG published two extensive review articles in 1980 and 1981 and presented an update in 1986 on the physical principles, methodologies, strengths and weaknesses and probability of success for technologies to detect hidden unexploded munitions. Since these reports, there have been a number of advances in the field of munitions detection which necessitate a comprehensive reassessment of technologies for munitions detection.

This report presents a discussion of the state-of-the-art in munitions detection. Standoff detection of surface-laid mines are not considered, nor are sea mines. Various technologies are presented and assessed vis-a-vis munition detection. Technologies have been divided into those that detect explosives directly and those that do not. Those that do not detect explosives include magnetostatics, electromagnetic induction, resistivity methods, microwave techniques, acoustics and optics. Those that detect explosives include radiofrequency resonance absorption, nuclear radiation methods, trace gas detection and biochemical detection.

"Smart" magnetometers and electromagnetic induction are relatively cheap, robust, have good penetration in soil and are very well suited for the location and identification of ferrous and metallic cased munitions at short distances (up to 2m). They should be the methods of choice for detection of metallic munitions. Prototype instruments which locate and identify metal-encased munitions have been demonstrated in the laboratory, but further work is needed to make them fieldable.

The remaining methods should be considered for detection of nonmetallic munitions or verification of detection of metallic munitions.

Electrical impedance tomography or conductivity imaging shows some potential to identify hidden conductive objects but at present images are crude and computer time is excessive. These are not limitations due to fundamental physics and work on algorithm refinement may eventually solve them. The role of impedance tomography would likely be detection of nonmetallic mines and verification of mine or UXO detections.

Ground probing radar (GPR) systems exist which are sensitive enough to detect nonmetallic mines but false alarm rates are very high. Advanced processing systems employing imaging and/or clutter reduction will be required

UNCLASSIFIED

Mammals are still the best explosives vapour detectors. Dogs are routinely used in the field for IED detection and have been used with some success for mine detection. *In vitro* biochemical detectors based on liquid phase enzyme reactions and immunoassay techniques to explosives are the most sensitive chemical detection method for TNT, by one to five orders of magnitude and are sensitive enough to detect nonmetallic mines in principle. At present the assays are done in liquid solution and are not performed in real time. It is not clear whether the methods can be adapted to aerosol sampling and real-time applications.

Combining a number of methods may decrease the false alarm rate, although there will be an attendant increase in cost and complexity.

UNCLASSIFIED

ABSTRACT

A review of the state-of-the-art in detection of hidden explosive munitions is presented. Technologies have been divided into those that detect explosives directly and those that do not. For each technology, the physical principles, methodologies, strengths and weaknesses and probability of success are discussed. Methods that do not detect explosives include magnetostatics, electromagnetic induction, impedance tomography, microwave techniques, acoustics and optics. Methods that detect explosives include radiofrequency resonance absorption, nuclear radiation methods, trace gas detection and biochemical detection. Metallic munitions appear to be best detected using magnetostatics and electromagnetic induction. Most other methods should then be chiefly considered for detection of nonmetallic munitions or verification of detection of metallic munitions. Some nuclear methods are in use for detection of bombs in baggage and show promise for nonmetallic mine detection. Nuclear magnetic resonance (NMR) has also been demonstrated to be able to detect bulk explosives in baggage and letters under practical constraints. The NMR detection of nonmetallic mines, although feasible, requires much more research. Trace gas detection shows promise for improvised explosive device (IED) detection, particularly for personnel inspection, but not for nonmetallic mine detection. Dogs and some small mammals are the only biodetectors which presently show promise for munition detection. *In vitro* biochemical detectors may eventually be useful for IED detection.

SANS CLASSIFICATION

RÉSUMÉ

Les derniers progrès en matière de détection de munitions explosives dissimulées sont passés en revue. Les technologies ont été réparties entre celles qui détectent les explosifs directement et celles qui ne le font pas. Pour chaque technologie, les principes physiques, les méthodes, les forces et les faiblesses, et la probabilité de succès sont analysés. Les méthodes qui ne détectent pas les explosifs comprennent la magnétostatique, l'induction électromagnétique, la tomographie à impédance, les techniques à hyperfréquences, l'acoustique et l'optique. Les méthodes qui détectent les explosifs comprennent l'absorption par résonance aux radiofréquences, les méthodes par rayonnements nucléaires, la détection de gaz traces et la détection biochimique. Les munitions métalliques semblent les plus faciles à détecter par magnétostatique et induction électromagnétique. La plupart des autres méthodes devraient donc être surtout considérées pour la détection des munitions non métalliques ou la vérification de la détection des munitions métalliques. Certaines méthodes nucléaires sont utilisées pour détecter les bombes dans les bagages et semblent prometteuses pour la détection des mines non métalliques. Il a aussi été démontré que la résonance magnétique nucléaire (RMN) permet de détecter les explosifs en vrac dans les bagages et les lettres dans des limites pratiques. La détection par RMN des mines non métalliques, quoique faisable, nécessite beaucoup de recherche. La détection par gaz traceurs est prometteuse pour la détection des dispositifs explosifs improvisés (DEI), particulièrement pour l'inspection du personnel, mais non pour la détection des mines non métalliques. Les chiens et certains petits mammifères sont les seuls biodétecteurs qui semblent actuellement capables de détecter les munitions. Des détecteurs biochimiques *in vitro* pourraient éventuellement servir à détecter les DEI.

CONTENTS

Introduction	1
Methods Which Do Not Detect Explosives Directly	3
Magnetostatics	3
Electromagnetic Induction	6
Resistivity Methods	8
Microwave Techniques	11
Acoustics	16
Optical Techniques	18
Methods Which Detect Explosives Directly	20
Radiofrequency Resonance Absorption Spectroscopy	20
Nuclear Radiation Methods	23
Trace Gas Analysis	31
Biochemical Detection	34
Conclusion	37
References	40

UNCLASSIFIED

LIST OF FIGURES

1. The intensity range of terrestrial magnetic fields and typical detectors.
2. Magnetic field intensity in a horizontal plane 0.55m above a prolate mild steel spheroid.
3. General method of location of a metallic munition by "smart" magnetometers and electromagnetic induction.
4. Concept of pattern classification for continuous design sets.
5. "Smart" total field magnetometer developed by DRES.
6. Method of transient electromagnetic induction.
7. Measured spatial variation of pulse induction response of a spheroid for a number of orientations.
8. Ratio of voltage induced in two pulse induction receive coils as a function of depth of object burial.
9. Voltage induced in pulse induction receive coil by a 0.08m radius steel sphere.
10. Vehicle mounted ordnance locator (VMOD).
11. The geometry of impedance tomography.
12. Results of reconstruction of a computer generated conductivity distribution.
13. The detection of buried munitions using active microwaves.
14. Speed of sound in a typical soil sample as a function of depth and acoustic ray path for different angles of incidence.
15. The disturbance of heat flow due to an object buried in a medium.

UNCLASSIFIED

19. NMR free induction decay showing orientation of magnetic moment vector at various points during the radiofrequency voltage waveform.
20. NMR spin echo showing orientation of magnetic moment vector at various points during the radiofrequency voltage waveform.
21. Schematic diagram of the $^{14}\text{N}(n, \gamma)^{15}\text{N}$ reaction
22. The schematic energy spectrum of the $^{14}\text{N}(n, \gamma)^{15}\text{N}$ reaction with a NaI(Tl) scintillation detector window centered at 10.8 MeV.
23. Schematic system for a vehicle mounted X-ray backscatter nonmetallic mine detector.
24. The mechanisms which effect vapour transport from an explosive munition.
25. Schematic diagram of an atmospheric pressure chemical ionization source mass spectrometer.
26. Schematic diagram of an ion mobility spectrometer.
27. Schematic diagram of a photoacoustic absorption trace gas detector.
28. Schematic diagram of a multipath cell/tunable diode laser trace gas detector.
29. Schematic diagram of the interaction of explosive molecules with the bioluminescence reaction chain.
30. Schematic diagram of enzymatic TNT detection.
31. Schematic diagram of the immunoassay method for TNT detection.

UNCLASSIFIED

LIST OF TABLES

1. Three classes of explosive munitions
2. Methods for detecting explosive munitions
3. Physical properties of explosives
4. Physical properties of soils
5. Physical and chemical properties of explosives vapours

INTRODUCTION

The Ordnance Detection Group (ODG) of the Defence Research Establishment Suffield (DRES) has been investigating the detection of buried ordnance, and buried and surface-laid land mines for a number of years. As a part of that program, they monitor and contribute to the current state-of-the-art in detection of explosive munitions. To aid in maintaining this knowledge base, ODG published two extensive review articles in 1980 and 1981 [1], [2] and presented an update in 1986 [3] on the principles, techniques and probability of success for methods to detect hidden unexploded munitions. Since 1981, and indeed even since 1986, there have been a number of advances in the field of munitions detection and it was thus felt that a comprehensive reassessment of techniques for munitions detection was necessary.

This paper, then, presents a discussion of the state-of-the-art in munitions detection. Various technologies are presented and assessed vis-a-vis munition detection. Because of the lack of wide spread availability of [3], some of the material in it has been duplicated although extensively updated. To save space, most references which were included in the review papers [1] and [2] have been omitted. Some references from [3] as well as numerous new references are included.

The detection of hidden explosive munitions may be roughly divided into three major problems:

1. detection of unexploded ordnance (UXO) such as buried artillery shells and aerial bombs,
2. detection of sea and land mines,
3. and detection of improvised explosive devices (IED) such as terrorist bombs.

Table 1 shows the main characteristics of explosive munitions. Methods to detect munitions cover virtually every scientific discipline. A number of methods which have been proposed to detect buried munitions are listed in Table 2. Note that the electromagnetic spectrum from 0 Hz to approximately

2×10^{21} Hz is spanned and that in addition to electromagnetics, the sciences of optics, acoustics, chemistry, biology, nuclear physics and magnetic resonance absorption are included. In spite of this enormous scope, no assertion is made that the list is exhaustive.

In the remainder of this report, we analyse each method as a potential detector of munitions. A review of techniques covering a number of technologies specific to mine detection is found in [4] and a discussion of some technologies for detection of buried ordnance (range clearance) is found in [5] and [6].

Among the types of explosive munitions, we will not discuss methods applicable to the detection of surface-laid scatterable mines from the air or sea mines. Although the former are explosive munitions, the problem is really one of detecting unhidden or partially hidden small metallic objects and is dramatically different from the traditional detection of buried mines. The methods used consist almost exclusively of active and passive optical wavelength (infrared to ultraviolet) imaging and high resolution high frequency microwave radar imaging methods. Sea mines involve detection at greater distances and in a highly conductive medium. Because of this, considerations for them are quite different than for the other munition types shown in Table 1.

As in past reviews, we will not consider parapsychological methods since there is to date no scientific evidence to support occasional anecdotal claims of their success as detectors.

METHODS WHICH DO NOT DETECT EXPLOSIVES DIRECTLY

The first major group of munitions detection methods includes those that do not detect explosives directly, but rather attempt to identify the munition based on properties of the explosive's container. Since IED may have a large variety of container materials and be surrounded by unknown substances, these technologies are not very suitable for IED detection. Among the methods considered are low frequency electromagnetic techniques, including magnetostatics, electromagnetic induction and resistivity methods, microwave techniques, acoustics and optical techniques. A good reference for low frequency electromagnetic detection of munitions is [7].

Magnetostatics

Magnetometers measure the weak disturbances in the earth's relatively uniform and approximately static magnetic field caused by ferrous objects. Since most artillery shells and many mines have steel casings, magnetometers are ideal candidates for the detection of such objects. Although the field intensities due to such objects are from one to four orders of magnitude less than that of the earth (Fig.1) [7], there are a number of available detectors which are sensitive enough to detect hidden ferrous munitions. Currently available commercial magnetometers provide an output that is proportional to the magnetic field intensity. The spatial distribution of the latter is related in a complicated fashion to the location of the object and the magnetic dipole moment. The latter is, in turn, a complicated function of shape, size, orientation and magnetic properties of the object. Subjective interpretation of the detector output by the operator at various points on the ground is necessary to guess the location and size of the object. This is further complicated by the fact that there may be large quantities of steel from exploded ordnance fragments or general ferrous debris.

The problem then is not so much one of developing more sensitive instruments, since sufficiently sensitive ones currently exist, but rather analysing the magnetic intensity as a function of position (Fig. 2) to locate and identify

the object associated with the magnetic field. "Smart magnetometers" carry out such an analysis using a computer, normally a microprocessor, and provide location and identity information directly to the operator (Fig. 3).

For practical ordnance detection, the magnetic field is dipolar and consequently the solution to the problem has two steps. First, the location and dipole moment of the magnetic dipole associated with the munition must be found. There are several techniques to do this, but only two are practical for munition detection. One, developed by Naval Coastal Systems Laboratory (NCSL) [8], requires a complicated eight-element vector magnetometer array and locates the dipole from one measurement in space. The other, developed by our group [9], may be used with a much simpler single element vector or total field sensor but requires multiple measurements in space. Both algorithms have advantages and disadvantages and both are capable of operating in real time on a microprocessor.

The second step is to identify the ferrous object using the output of the location algorithm, namely the measured dipole moment of the object. This may be done by a technique called pattern classification in which sets of quantities derived from measurements, called "feature vectors", are compared. The pattern classification process involves comparing the feature vector of an unknown object ("test vector") with a set of stored feature vectors corresponding to a set of known objects ("design set"). This is simply illustrated in Fig. 4, for a two dimensional (F_1, F_2) feature space. Three classes, O_i , ($i = 1, 2, 3$) are shown, each composed of a continuous design set L_i which is a function of a continuous parameter θ . The minimum distance from the test vector ("unknown") to each class is estimated, using a suitable metric, and the vector is assigned to the class corresponding to the minimum distance. (For more information on pattern classification, see for example [10]). For magnetostatics and electromagnetic induction, design sets are typically continuous functions of one or more parameters. For magnetostatic detection, it is convenient to use the 3 dimensional dipole moment vector as the feature vector. The dipole moment of a compact object is a function of its orientation (2 angles) and so is characterized by a continuous surface of dipole moments. To store the surface for each class of objects in a computer, the surface must be approximated by a finite number of dipole measurements. DRES has developed a novel pattern classifier [11] which reconstructs the surface from the design set (measured at 15° increments) and then estimates the class and orientation of the object.

A detector that could locate and identify a compact ferrous object would represent a major advance over the present state-of-the-art. A self-contained "smart" magnetometer, which can be used in a man-portable or vehicle-mounted role has been constructed at our laboratory [12]. It collects

simultaneous magnetic and position data and estimates location and identity of compact, axially symmetric, ferrous objects.

The instrument (Fig. 5) consists of a commercial total field magnetometer (self-oscillating cesium vapour, made by Scintrex, Concord, ON, Canada), a wheel-mounted shaft encoder serving as a linear position sensor, and a 16/32 bit microprocessor which controls data collection and algorithm execution. The microprocessor electronics, including a keypad and digital liquid crystal display is housed in a 10 cm by 20 cm by 4 cm box. Power is supplied by the magnetometer battery pack. The above mentioned DRES location algorithm is used to estimate the location and dipole moment of the magnetic dipole associated with the detected object and the DRES dipole moment pattern classifier is used to identify the object. The instrument instructs the operator when and where to make field measurements. It operates in a locate/identify mode for unknown objects and an improved version, under development, will include a learning mode when acquiring a design set from known objects.

The location algorithm takes less than one second to execute on an 8MHz Motorola M68000 and the identification algorithm takes about four minutes for an eight object design set. Calculations show that the latter time can be straightforwardly reduced to less than a minute by using a numeric coprocessor and higher clock speed.

Preliminary magnetic field measurements of a ferrous sphere and a spheroid have been made in the DRES nonmetallic laboratory to test the location and identification method. Reproducibility experiments show that in the current configuration, the instrument can estimate location with an rms uncertainty of roughly 4 cm and dipole moments with an rms error of approximately 20%. If measured design sets were obtained for the real objects, misclassification errors of less than 14% should be possible. It is expected that these errors can be readily reduced by at least a factor of two.

A multi-element fluxgate "smart" gradiometer system for UXO location and identification is currently under development by DRES and Pylon Electronics (Ottawa, Canada). It will incorporate the NCSL gradient location algorithm and DRES dipole pattern classifier. Although the hardware will be more complicated than the above mentioned smart magnetometer, the gradiometer will allow compact ferrous objects to be located and identified from a single measurement in space, it will allow design sets to be stored from measurements and it will not need a position measurement system. The estimated completion date is December 1991.

With regards to advanced fielded systems, a vehicle-towed detector array for locating magnetic anomalies over areas of several thousand square meters is under development by Geo-Centers for the US Navy [13]. The de-

vice, called STOLS, consists of a set of commercially available cesium vapour magnetometers and a microwave triangulation position measurement system connected to a data collection system. Data is processed off-line to produce field intensity maps which can be interpreted to roughly locate magnetic objects. Further, compact magnetic objects such as artillery shells can be located more accurately and roughly grouped in size, based on dipole strength, using a nonlinear least squares dipole locator algorithm developed by DRES [14]. A similar magnetic field mapping instrument is under development in Australia [15].

One of the biggest problems facing magnetic detection in the future will be accurate determination of the sensor position. The percentage uncertainty in location estimate is approximately equal to that of the sensor position and the percentage uncertainty in dipole moment estimate is roughly three times that of the location estimate. In practical terms this means that sensor position uncertainties must be kept to less than 0.1 m if accurate identification is to be achieved. It should be noted, however, that the smart gradiometer does not need a position measurement system. One can "home in" on the target by making a measurement, using the bearing and range information to move closer to the correct location and repeating the process until directly over the target.

As a final note, detection of minimum steel mines may be enhanced by sweeping an electromagnet ahead of a magnetometer to premagnetize the steel in the mine. It is not clear whether such a method is practical and to date to our knowledge, no work has been done on the subject.

Electromagnetic Induction

Electromagnetic induction (EMI) consists of exposing a conductive object to a time-varying magnetic field (usually produced by a time-varying electric current in a loop of wire) and detecting (usually by a second loop of wire) the secondary magnetic field produced by eddy currents induced in the object. Since buried ordnance and many mines have metallic casings or components, they are amenable to detection by this method. The most robust technique for munition location and identification is the transient method. In this technique, a primary current in a transmitter loop is switched on and off repeatedly and detection is achieved by coherently adding the voltage waveforms in one or more receive loops (Fig. 6).

All commercial electromagnetic induction detectors, most of which are continuous wave rather than transient, produce an output which is proportional to the strength of the signal produced by the object. Signal strength is

dependent in a complicated way on object depth, size and material properties and these factors cannot be separated. "Smart" electromagnetic induction detectors (Fig. 3) use a computer to analyse temporal or spatial variations of the received voltage to present location and identity information directly to the operator. ("Smart" detectors, unlike conventional ones, can also have programmable electronic and data collection parameters, which is very desirable if the detector is to be multipurpose, such as for mine and UXO detection.)

Location in a horizontal plane is fairly straightforward. If the amplitude of the signal due to a compact object is measured in a horizontal plane, the center of the object usually situated directly under the peak of the amplitude [16], [17]. Occasionally the signal in the plane may have two peaks, in which case the object center is below the center of the trough between the two peaks (Fig. 7). For coaxial coils, the accuracy in location is a small percentage (typically <10%) of the larger of the receive and transmit coil diameters. Determining depth is more difficult. However, research by DRES has found a method for accurately estimating depth. It turns out that for objects and geometries typical of ordnance detection applications, the ratio of signals in two different receive loops is a function of object depth, independent of object size, shape or orientation [18] (Fig.8). Determination of location, including depth, using two receive coil detectors has been demonstrated in the DRES laboratory.

Identification of metallic munitions by electromagnetic induction is a much more difficult problem than location. The response of an object is a sum of damped exponentials (Fig. 9). The exponential amplitude and decay parameters may be related to the orientation, size, shape and material properties of the object. The relationship varies from one object type to another and may be simple or complicated. Most often, the relationship cannot be expressed analytically. In any case, even for the ferrous sphere, for which the relationship is simple, it is generally impossible to determine the decay coefficients themselves. The simple technique of fitting the tail of the response to a single exponential does not succeed because the terms that decay faster have higher initial amplitudes and no part of the response is dominated by a single exponential. Model fitting techniques, including least squares fitting and Prony's method, fail because damped exponentials are highly correlated. DRES has achieved some success in identification using pattern classification.

In experiments in a nonmetallic laboratory, pulse induction (transient electromagnetic induction with a pulsed transmitter waveform) responses for four steel spheroids, similar in dimensions to artillery shells, were collected at different orientations and depths. Each response was normalized and divided into time segments and the mean value for each segment was chosen as a

component of the feature vector. The design set for an object consisted of the feature vectors for all orientations (15° increments) at a given depth. A continuous parameter pattern classifier [19], similar to the one used in magnetostatics, was able to classify the objects with a probability of misclassification of about 1% if the design and test sets were obtained for the same object depth. If the two sets were taken from depths differing by 0.1 m, the probability increased to about 11%. This decrease in performance occurs because the normalized responses are slowly varying functions of object depth. Thus to improve accuracy of classification in future work, a large number of responses will be needed for the design set for each object unless a simple method of compensating each feature vector for depth can be developed.

A first example of a "smart" pulsed induction detector is the vehicle mounted ordnance detector (VMOD) (Fig. 10), developed by DRES and Pylon Electronics, and marketed by the latter, for ordnance location [16], [17]. The VMOD was designed for rapid scanning and as such does not, as mentioned above, use a two receive coils to estimate depth and a pattern classifier for identification. However, the spatial profiles are presented to the operator who can use their shape and width to infer location with reasonable accuracy and rough size. A previous prototype has been tested extensively on an ordnance test range at DRES and has performed well in actual clearance operations on the DRES Experimental Proving Grounds.

Spatial analysis alone can provide reasonable location estimates but only rough identification. Thus, a second "smart" pulse induction detector is also under development by DRES for use as a hand-held locator and identifier. The electronics consists of receiver and transmitter electronics, signal conditioning, high speed A/D converters and a 16/32 bit microprocessor. It employs two receive coils to determine the object depth and will use the DRES pattern classifier algorithm to identify the detected object. The hardware is complete and has been tested. All the software components have been written but it has not all yet been completely integrated.

Resistivity Methods

Resistivity methods (also called D.C. conduction methods or resistivity surveying) involve measuring an effective electrical impedance of a medium, generally by injecting current into the medium and measuring surface potentials. Conventional geoexploration techniques such as Wenner arrays are of little use for munitions detection, since interpretation of results requires the assumption of a model which is too simple or inappropriate, such as a multi-layered half-space. More information on resistivity methods may be found in

[7].

Impedance tomography or conductivity imaging is an extension of the resistivity method which has been attempted with limited success for geophysical and biomedical imaging [20], [21]. One version, being developed by Quantic Laboratories (Winnipeg, Canada) under contract to DRES, is being applied to the detection of hidden explosive objects [22], [23]. The method is shown schematically in Fig. 11. The quantity κ is the conductivity of the subsurface region and generally is a function of the coordinates (X, Y, Z) . It is to be determined. A grid of electrodes is placed on the ground. An excitation consists of injecting current J_{in} into one electrode, withdrawing it from another and measuring the electrical potential ϕ_k with respect to reference electrode ϕ_{ref} at electrodes $k = 1, 2, \dots, n$. To increase the available information, two other current electrodes are chosen and potentials again measured. This is repeated for a number of permutations of the electrodes.

The algorithm is too involved to detail here, and only a rudimentary outline is given. For details, see [7], [24]. Essentially, a finite element method is used to linearize the field equations within the subsurface volume. The set of linear equations are solved using a preconditioned conjugate gradient method. At each iteration step, the boundary value problem is solved twice using Dirichlet and Neumann conditions for an assumed conductivity distribution. Since Dirichlet and Neumann boundary conditions are each sufficient to solve the boundary value problem, the two solutions can be used to provide an improved estimate for the conductivity distribution for the next iteration. Specifically, the algorithmic steps are:

1. Establish a Finite Element Mesh - Assume the region of interest to be bounded by a cube which includes the measurement surface as one face. Potentials are computed for each excitation at the node points (mesh intersections) and the conductivity is then estimated within the intervening regions. The conductivity distribution in the region of interest is initially assumed to be uniform and the following iterative procedure to improve the conductivity estimates is then applied.
2. Calculate internal current density with Neumann boundary conditions - Using the distribution of conductivity κ from the previous iteration and the measured impressed current source distribution f , compute the potential distribution ψ_1 from the Poisson equation ($\nabla \cdot \kappa \nabla \psi_1 = -f$) and inhomogeneous Neumann boundary conditions on the measurement surface. Compute the current density distribution \vec{J}_1 from Ohm's Law ($\vec{J}_1 = \kappa \nabla \psi_1$). This step is repeated for all other excitations and the resulting fields are stored.

3. Calculate internal potential with Dirichlet boundary conditions - The interior potentials ψ_2 are calculated using Dirichlet boundary conditions, on the measurement surface (except at the current electrodes where Neumann are used).
4. Calculation of conductivity - Minimize the residual R with respect to the set of conductivities κ_i . Subscript i corresponds to finite element V_i ,

$$R = \sum_x \sum_j \int \int \int_{V_j} (\vec{J}_1 + \kappa_j \nabla \psi_2)^2 dv , \quad (1)$$

\vec{J}_1 and ψ_2 are those estimated for iteration steps 2 and 3, and x denotes an excitation. This yields an improved estimate for the conductivity in each element,

$$\kappa_i = - \frac{\sum_x \int \int \int_{V_i} \vec{J}_1 \cdot \nabla \psi_2 dv}{\sum_x \int \int \int_{V_i} \nabla \psi_2 \cdot \nabla \psi_2 dv} \quad (2)$$

5. Recursive improvement - Steps 2, 3 and 4 constitute an iteration. The next iteration begins again by solving the Neumann boundary value problem for all excitations using the new conductivity distribution estimate. The computed potentials at the boundary are compared with the measured ones. If the differences exceed some *a priori* thresholds or if insufficient iterations have been performed, the iteration continues with the solution of the Dirichlet boundary value problem. Otherwise the resulting image (2D or 3D depending on the problem) of the conductivity distribution is processed by one of a number of standard techniques and presented.

Impedance tomography shows some potential to identify buried conductive objects. It appears that impedance measurements can be made with accuracy sufficient to allow good image reconstruction. The latest research [24] on the algorithm has attempted to reduce computer time to approximately 1 minute per image. By exploiting parallelism in the algorithm, such times appear to be achievable using a transputer array. The algorithm has, in fact, been rewritten to exploit parallelism so that it could execute on a transputer array or other MIMD parallel computer architecture.

For the two dimensional problem (i.e., two dimensional conductivity distribution, measurements on a line boundary) sufficient resolution has been obtained so that an elliptical object can be clearly discerned. For the three dimensional case (Fig. 11) which is applicable to mine and artillery shell detection, there are problems with solution stability, caused in part by inadequate

modelling of the electrodes. Nevertheless, adequate image reconstruction has been achieved in some cases.

A simple if somewhat contrived example of the three dimensional case, namely a cube with four layers of finite elements is shown in Fig. 12 (see [7]). Layers two and three contain an object of square cross section whose conductivity is five times the host medium. Simulated "measurements" have been made at the top surface only. Clearly the estimate improves with iteration count. Initially a conductivity artifact appears at the surface but it later disappears. Note that a large number of iterations are needed and even then the image is quite crude. Objects of a more general shape tend to be even more crudely imaged. Furthermore, computer time is excessive, being of the order of an hour on a large mainframe computer. Work is underway to solve both the accuracy and speed problems.

Other less fundamental problems must also be addressed, notably the logistics of planting electrode grids in the ground and making rapid measurements. One major advantage of impedance tomography is the potential to image nonmetallic mines since their cases may have different conductivities than soil or other artifacts in the ground.

Microwave Techniques

Active techniques discussed under this heading are referred to by various names in the literature such as electromagnetic radar, ground probing radar (GPR) or subsurface radar. Passive techniques are referred to as microwave radiometry and are discussed at the end of this section. These techniques can detect both metallic and non-metallic objects. Because of the success of low frequency electromagnetic techniques for location and identification of metallic ordnance (see Magnetostatics and Electromagnetic Induction), we will concentrate mainly on the detection of non-metallic mines in this section. We exclude IED from consideration, since the geometries and surrounding materials are too diverse for general consideration.

The idea of using electromagnetic signals to probe the earth dates back to the beginning of this century and commercial GPR units have been available for at least twenty years. An excellent discussion of the various aspects of subsurface radar technology and a review of recent work in this area can be found in the Special Issue [25] of IEE Proceedings(F) on subsurface radar. In this special issue, the paper by Daniels *et al.* [26] which contains more than 200 references gives, to the best of our knowledge, the most comprehensive general review of GPR technology. The paper by Chignell *et al.* [27] discusses the specific problem of mine detection using GPR. Other papers concern details

of advanced GPR signal processing techniques such as holographic imaging, synthetic aperture processing etc. DRES recently sponsored a study for a critical review and assessment of the state-of-the-art in order to identify promising new avenues, if any, to pursue in GPR research with a view to developing a reliable detector for nonmetallic mines. The report [28] resulting from this study is an excellent summary and review of the work conducted in various countries and of opinions of international experts.

The basic principle of operation of a GPR is as follows (Fig. 13). Electromagnetic energy, usually in the hundreds of MHz to GHz range, is transmitted into the ground using a suitable waveform scheme (e.g., impulse, CW, FM-CW, step-frequency, etc.). A large part of this signal is reflected back to the radar receiver from the ground-air interface. Ways of reducing this signal and distinguishing it from returns (usually much smaller) due to wanted targets buried in the soil is a major consideration in GPR design. The remaining signal that penetrates the ground is attenuated due to absorption losses and is scattered as it propagates in the soil due to the non-uniformity of its electromagnetic properties (such as dielectric constant, conductivity). The signal eventually reaching a target such as a munition or a rock (which can be considered as an isolated discontinuity in soil electromagnetic property) gets scattered by it and part of this signal propagates back to the GPR receiver in the air, having been subjected to attenuation and scattering as on its way down to the target. The attenuation reduces the amount of signal to and from the target and the scattering produces clutter which limits the minimum detectable target signal and hence the usable system sensitivity. Signal attenuation is a strong function of soil moisture content and signal frequency. Clutter depends on the degree and detailed characteristics of non-homogeneity of electromagnetic properties of soil and hence is expected to be variable. Signal scattered by the target depends on factors such as the size, shape and orientation of the target, frequency of the radar and the difference in electromagnetic properties between the target and the host medium. While attenuation characteristics of soil, the strong return at the air-soil interface and scattering by various targets have been studied to some extent, there does not appear to have been much work in the area of characterization of clutter due to the top layer of potential host media such as soil. Such study may be crucial in improving the performance of GPR in detecting ordnance.

The use of subsurface radar has been successful in a number of applications such as the probing of ice, mapping of utility lines, civil engineering applications etc. In spite of this success in other fields, the detection of buried ordnance - non-metallic mines in particular - continues to be one of the most difficult problems for GPR technology. The problems unique to the detection

of mines, which are small discrete objects, are discussed in detail in [27] and [28].

GPR of various designs (e.g., impulse, CW, step frequency) have been developed over the last two decades for the detection of buried mines. Some recent examples are the systems developed for Vehicle Mounted Mine Locator (VMML) projects of the U.S.A and West Germany, the system developed by ERA Technology of the U.K. and the Step Frequency Radar System being developed by the University of Toronto in Canada. To the best of our knowledge, none of these systems have yet met the operational requirements of the user and the deficiency pointed out most often has been high false/nuisance alarm rates due to such unavoidable factors as ever-present non-targets (e.g., rocks, organic matter etc.) and naturally occurring small-scale (same order as targets sought) variation of soil properties (e.g., homogeneity, moisture content etc.).

Because of the rather discouraging past described above, organizations involved in the development of GPR for mine detection have decided to go back to basics and look at the fundamentals of the technology. As previously mentioned, [28] is a report resulting from one such study. Detailed discussion of the conclusions and recommendations of this study is beyond the scope of this paper. In short, the study was unable, as had been expected, to identify one single avenue of research that would substantially improve the capability of GPR in detecting plastic mines. Instead, the study recommended a number of possible research directions that may be of use. Some of the issues discussed during this study follow.

- (a) Based on a simple system analysis using parameters typical in a mine detection scenario the study concluded that existing hardware (hardware described in [27] for example) was adequately sensitive to detect returns from plastic mines and that effort to improve on hardware sensitivity will have diminishing return at this stage. The parameters used for the analysis were: plastic mine with diameter $\geq 0.1\text{m}$ buried in wet soil (attenuation $10\text{--}100\text{dB/m}$) to a depth of 0.3 m ; the dielectric constant of soil was taken as 16 and that of the plastic mine 3 (effect of other values of dielectric contrast between host soil and the mine was also studied and it was pointed out that there may be situations, in dryer soil for example, where the two dielectric constants may be so close to each other that no signal would be reflected by the target); centre frequency of 1 GHz , a bandwidth of $\geq 500\text{MHz}$ and a system performance of 140 dB was used. The analysis accounted for signal loss due to reflection from the soil surface. The effect of clutter due to the interior of the

host medium was not included.

- (b) In practice, however, the above detection performance will not be achieved primarily because of the clutter that is produced when an electromagnetic wave propagates in a random, inhomogeneous medium like soil. The amplitude of this clutter will set the limit on the smallest target signal that can be reliably detected. Thus finding techniques to reduce the effect of this clutter is the key to improving the usable sensitivity of GPR systems. This task is made very difficult by the variability of clutter with respect to location in the same host medium, frequency, etc. Thus future research must put in an effort in finding ways to characterize this clutter and reduce its effect. Some possible areas of continued investigation in this regard are: (1) use of multi-element antenna arrays to achieve desired focusing; (2) use of a number of GPRs operating in different frequency bands which may allow (i) optimum selection of frequency for a given soil conductivity (ii) reduction of clutter by taking advantage of its possible variation with frequency and (iii) use of processing concepts developed for improved imaging through an aberrating, diffusing medium [29]; (3) theoretical and experimental study of volume scattering within the top soil layer for improved clutter characterization.
- (c) In addition to the general clutter described above, there will be situations where isolated discrete regions, similar in size to targets being sought, of discontinuity in electrical property will naturally occur (due to rocks, voids, roots, junk, moisture variation, etc.) in the host medium and will be detected as targets. Since a GPR's basic function is to detect such electrical discontinuities, there is no simple way to avoid such 'nuisance' alarms. Ingenious signal processing algorithms [27] and pattern recognition concepts [30] have been employed in an attempt to alleviate this nuisance alarm problem. Such efforts appear to have had only limited success to date. Future research to investigate ways of distinguishing between mine and non-mine signatures should include: (1) Develop improved pattern recognition schemes. (2) Study actual mines and explosive fillings and their signatures to find possible additional attributes (e.g., metal content, high loss tangent, electromagnetic emission, electronic components, etc.) that can aid pattern recognition or can point to complementary sensors. (3) Develop processing techniques that can utilize the possible regularity in spatial response of a man-made

object such as a mine in contrast to that of a natural object which is likely to be irregular. (4) Investigate synthetic aperture processing and possibility of target imaging in situations where clutter and attenuation conditions will permit such processing.

It is all too easy, as we have done above, to fall prey to 'signal processing' and expect it to solve all difficult problems. Obviously, a lot of the ideas that we have summarized above can be usefully investigated only if there is enough scattered signal from the target under the existing conditions of clutter and attenuation in the obscuring host medium. While it is obviously desirable to have a system that can detect all types and sizes of mines under all scenarios of interest without producing substantial number of false alarms, it is very unlikely, if not impossible that this level of performance will ever be reached with GPR due to inherent limitations imposed by the laws of physics. It should be pointed out that the degree of reliability that the user has come to expect from conventional metal detection technology in detecting metallic ordnance will possibly never be matched by GPR's ability to detect non-metallic ordnance. Because of this, efforts to technologically improve the performance of GPR for mine detection should be accompanied by efforts to identify operational requirements that can be adequately met with present and projected technology.

Before closing this discussion on microwave techniques, it should be mentioned that radiometers which measure radiation in the microwave band were investigated as buried-mine detectors about 25 years ago [31]. These detectors measure the emitted and reflected radiation from the target. Radiometers were discarded as a means of mine detection because of excessive false alarms in field situations due to, among other things, natural moisture variation. We are not aware of any other work since then in this area. Recently, DRES has sponsored a study to investigate the feasibility of using millimeter-wave radiometry to detect surface-laid metallic and non-metallic mines. This technique would have most of the disadvantages of thermal infrared detection (see Optical Techniques) while possessing inferior spatial resolution. However, it will have better penetration capability in dust and smoke and may be a useful complementary detector in a vehicle-mounted or airborne role.

Radiometers are expected to have the same problems as discussed in [31] in detecting buried mines, and to be restricted by some of the same natural causes that plague an active GPR as discussed here. Having said that, it might be interesting to take another look at microwave radiometry for buried object detection in the light of the technological improvements in radiometry in the last 25 years.

Acoustics

Since munitions, with the possible exception of some IEDs, do not emit acoustic radiation, we will consider only active methods in which acoustic radiation is emitted by the detector system. Active acoustic methods are based on injecting acoustic energy into the volume in which the munition is hidden and then measuring reflections of acoustic energy caused by the difference between the acoustic impedance of explosives or their case materials and that of the surrounding materials. Acoustic impedance is a function of mass density, bulk modulus and wavelength. It is well known that acoustic impedances of explosives differ from those of many common materials but explosives cannot be uniquely discriminated from these materials on the basis of density alone. If dual wavelength sound waves are used, it is possible to estimate both density and bulk modulus, which will reduce the false alarm rate. (This is similar to X-ray scattering, in which charge density and atomic number can be resolved by using dual energies as discussed in Nuclear Radiation Methods).

Acoustic detection technology has reached a mature state, driven mainly by the geoexploration and anti-submarine detection problems. Reliable, cheap sources and detectors exist. Using opto-acoustic techniques to detect acoustic emissions from within the inspection volume, it is possible to have high signal-to-noise (S/N) detection (far in excess of microphonic methods) without the detector touching the surface of the material hiding the munition.

For munition detection, acoustic time domain reflectometry without imaging is not very useful because of the frequent returns from natural objects near the munition and from inhomogeneities in the media which hide the munition. These are often indistinguishable from returns due to the munition, which may have varying types of case materials. Such inhomogeneities in the media also make imaging difficult. To illustrate this for mine detection, the upper graph of Fig. 14 shows the velocity profile below the surface of typical soil (based on data from [32]). The lower graph shows the paths of acoustic rays of differing angles of incidence and is calculated from the velocity profile. Ray paths are not straight lines, and are in some cases totally reflected. From an imaging perspective, this leaves standard tomographic imaging techniques of little use since the ray paths are impossible to predict *a priori*. One possible solution is to extend the impedance tomography algorithm discussed in Resistivity Methods to acoustic imaging since the field equations are similar for the two problems and the algorithm makes no assumptions about ray paths.

Some preliminary work has been done using opto-acoustic methods for detection of IED in airline baggage [33]. The experiments distinguished

samples of single materials in holders, some with a suitcase face in front of them. This was a simplistic geometry and used a wavelength of roughly 8 cm which was too long for adequate imaging. The study did not demonstrate the determination of impedances in a volume which is inhomogeneous in width as well as depth (i.e., explosives in a jumble of other materials). As we shall see in Nuclear Radiation Methods, prototype nuclear-based bulk explosives detection systems have been trialed successfully for baggage inspection in the U.S.A. These systems are expensive but nevertheless affordable. Acoustics must prove itself to be superior to such systems, but there is no evidence to suggest that it will be so.

Limited research has also been done on active acoustic detection of buried land mines. Morita [34] demonstrated in laboratory soil box experiments that metallic and nonmetallic mines can be detected with adequate S/N when buried up to 30 cm in soil. He determined that the optimum frequency for detection to maximize S/N was about 3 KHz. It was noted that speed of sound was fairly independent of frequency and moisture content in sand (~ 178 m/s) but changed substantially with moisture content (~ 143 m/s dry to ~ 256 m/s at 8% moisture) in sand-clay. As illustrated above, this is in agreement with other sources that show that the natural soil is very inhomogeneous, causing rapid changes in the speed of sound [32]. Multimode propagation should further complicate analysis, although Morita found interference of surface waves did not pose much of a problem. Morita did not attempt any imaging and the study does not address the above mentioned problems regarding imaging and the variation of the speed of sound. In fact, the authors are unaware of any study which has demonstrated acoustic imaging of mines at operationally acceptable spatial resolutions or even shown evidence that suggests such imaging can be achieved. Thus at this stage, one must conclude that detection of deep mines with acceptable false alarm rates is difficult to achieve. Mines which are shallowly buried (roughly < 12 cm) may still be detectable, since high frequencies can be used. Thus, an appropriate antenna could produce a very narrow "spot" beam which could raster scan the ground surface to produce an image of high spatial resolution. Ray paths might be straight lines because of the small penetration (Fig. 14), but it is not clear how the freshly disturbed soil above the mine would affect the image quality.

Optical Techniques

Since the penetration of optical wavelength electromagnetic radiation in opaque materials is negligible, the only optical techniques to consider are

those which measure a surface property of the material hiding the munition, in hopes that the surface property is affected by the presence of the munition.

Thermal infrared detection or infrared radiometry relies on measuring the spectrum or intensity of infrared radiation emanating from a material. If a mine is buried in a medium such as soil (Fig. 15), the normal heat flow pattern in the soil will be altered if the thermal properties of the object and disturbed medium around it are sufficiently different from those of the undisturbed medium. This will cause a change in the temperature profile above the surface of the medium directly above the occlusion. Because the diurnal variation of solar radiation is the driving mechanism for the heat flow, models and experiments [2], [35] show that the temperature of the medium will be oscillatory with a period of roughly 24 hours (Fig. 16). The amplitude of oscillation decreases exponentially with a diffusion length of approximately 0.1 m. There will also be a phase lag of approximately 2 hours per 0.05 meters of depth. The buried object will alter both the phase lag (~ 0.5 to 0.75 hours for nonmetallic mines) and amplitude ($\sim 2^\circ\text{C}$ maximum for a nonmetallic mine at 0.175 m depth) of temperature variations at the surface. These changes rapidly approach zero as the object depth increases beyond the diffusion length. Soil and surface objects tend to radiate in a manner similar to a black or gray body. Temperature changes of the two types are manifested as both spectral and intensity changes in the emitted infrared radiation. This is illustrated in Fig. 17 where both a change in total radiated power and a shift in peak power wavelength (λ) are observed. It is unlikely that such a method would be of use for IED detection. Providing the IED does not itself emit a significant quantity of heat, there is no driving heat source. Also, the wide variation of materials that may hide explosives makes it likely that the medium will contain many false alarms.

Practical experiments [2] have shown that although simulated non-metallic mines could be detected at depths of up to 0.175 m, even very homogeneous sand yielded many repeatable radiation emission anomalies which would be considered false alarms. This is likely due to variations in the emissivity throughout the medium.

There are components of proteins in bacteria, such as the amino acid tryptophan, which fluoresce when irradiated with ultraviolet light. If soil has been recently disturbed, bacteria which are normally present underneath the soil surface could be detected by shining a UV laser on the area and observing the subsequent fluorescent radiation. The method would detect disturbed soil which in turn could suggest a buried mine. The chief problems are that all soil disturbances are detected, fluorescence is a very inefficient process, which necessitates powerful laser sources, and the method is useful only for freshly

buried mines, since the bacteria migrate back into the soil. To the authors' knowledge the method has not been attempted for mine detection although it has been used in some remote sensing experiments [36].

METHODS WHICH DETECT EXPLOSIVES DIRECTLY

The methods in this section detect the explosive in a munition. As such, their primary role will be detection of nonmetallic munitions or verification that a metal object has an explosive filling for situations where metallic clutter background is high.

A thorough index of references for explosives detection is presented in [37]. Other references which provide information on the present state-of-the-art in explosives detection are [38], [39], and [40].

Explosives detection methods are classed as either vapour detection or bulk detection methods. The former, which include trace gas detection and biochemical detection, involve identifying the specific explosives molecules themselves. The latter, which include radiofrequency resonance absorption (with the exception of microwave molecular absorption) and nuclear radiation methods, look for a property present in explosives which is not present in naturally occurring materials. The physical properties of explosives are shown in Table 3 [41]. The physical properties of explosives vary but their densities are similar (between 1.6 and 1.8 g/cm³) and they all have a large relative abundance of nitrogen (10 to 40%). Many naturally occurring materials have similar densities, such as soil (Table 4) [42], plastics, foodstuffs, but few have anywhere near as much nitrogen (soils have between 0 and 0.1%). This makes detection of nitrogen a good approach for bulk explosives detection.

Radiofrequency Resonance Absorption Spectroscopy

Radiofrequency resonance absorption spectroscopy (RRAS) methods all involve selective absorption of energy from an electromagnetic field due to resonances formed by interactions between the electric or magnetic moments of nuclei or electrons of atoms and external or internal fields. There are four basic methods - nuclear magnetic resonance (NMR), nuclear quadrupole resonance (NQR), electron paramagnetic resonance (EPR), and microwave molecular absorption (MMA). MMA is observable only in gases and as such is far less sensitive than the other trace gas analysis methods to be discussed below.

There are two types of NMR - steady state and transient. Transient NMR is more than a thousand times more sensitive to solids than steady state and can be made less susceptible to magnetic field inhomogeneities. Because of this, the transient method is more useful for munition detection.

A simplified discussion of transient NMR follows. The detailed theory may be found in [51] (see also [1], [2], [3]). A large steady state magnetic field (H_0) is applied to the object using a DC magnet system. In addition, a smaller radiofrequency (Larmor frequency) magnetic field pulse is applied perpendicular to the steady state field. The vector sum of the magnetic moments of the nuclei can be represented as a single vector, M_0 , which precesses at the Larmor frequency about the steady state field and in the absence of an RF field exponentially approaches alignment with H_0 with a spin lattice time constant T_1 . The Larmor frequency is linearly proportional to the magnetic field with a constant of proportionality which is fixed for a given nucleus. The nuclei to be considered for explosives are hydrogen and nitrogen, the former having a 13.8 times larger Larmor frequency than the latter for the same field strength. In a coordinate system which rotates with the magnetic moment vector and whose z' axis is aligned with H_0 , M_0 is initially aligned with the z' axis (Fig. 19). The RF field, applied along the x' axis, will cause the moment vector to rotate about that axis through an angle proportional to the pulse duration. Two transient methods are commonly used for explosives detection. In a free induction decay (FID) (Fig. 19), the RF field is turned on for a sufficient length of time to rotate the moment vector 90° to the y' axis. A pulse of such duration is called a 90° pulse. Internal and external fields cause the individual moments to dephase which decreases the magnitude of M_0 . The decrease of the magnitude of M_0 along the y' axis is measured by a coil whose axis is perpendicular to the z' axis. The reciprocal time constant is the sum of the reciprocal of spin-spin relaxation time T_2 , and a term which is proportional to the field inhomogeneity. The previous statement assumes that molecular diffusion is negligible, as is usually the case for a solid, and that the magnetic field gradient is not very large. The spin spin relaxation time is specific for a particular nucleus in a particular material and thus a measure of it will allow determination of the material. In spin echo NMR (Fig. 20) a 90° pulse is followed after time τ by a 180° pulse. The signal is then measured at time 2τ . The spins initially dephase but the second RF pulse causes them to rephase forming a spin echo at time 2τ . The time constant for the spin echo can be shown to be equal to T_2 and is independent of the field inhomogeneity. The long spin-lattice relaxation time, T_1 , of solid explosives can require long waiting periods (up to 1500 s) between pulse sequences to realign M_0 with H_0 . There are special sequences which can minimize the problem [1], [2], [44].

Prototype systems for the NMR detection of explosives in baggage have been built [46]. They operate at approximately 700 Gauss corresponding to a 3 MHz Larmor frequency and can typically detect as little as a few hundred grams of explosives (except black powder) [45]. For nitrogen NMR, at the same Larmor frequency (field of 9760 Gauss), the S/N ratios are about 10 times smaller. Magnets producing such fields in a 100 by 60 by 7 cm volume weigh about 1200 kg and consume less than 2000 watts of power. RF pulses must deliver peak magnetic fields at the sample of several hundred Gauss with durations of a few microseconds. This requires powerful (100-1000 V) bursts of RF power.

The problem of bombs in mail is somewhat simpler because the inspection volume is generally smaller than for baggage. This allows more intense and more uniform magnetic fields in the inspection volume and closer proximity of detection coils which results in larger S/N ratios. Prototype hydrogen NMR mail bomb detectors have been built [47] which are capable of detecting 10g of RDX or 50g of PETN. In addition, an NMR system for detection of cocaine in mail has been field tested at the Worldways Postal Center in Los Angeles. Out of 3350 letters, 5 cocaine samples were detected with only 2 false alarms [48]. Adaptation of such a system to explosives would not be difficult.

The baggage and postal problems involve a favourable geometry in which the object being inspected is between and near the poles of the DC magnet and near the RF coil(s). In some problems, such as the detection of nonmetallic mines, this favourable geometry does not occur. The geometry for NMR detection of a buried mine is shown schematically in Fig. 18. (Steady state field lines are shown as dotted curves and RF field lines are solid.) This so-called "remote" or "one-sided" detection problem, is much more challenging because the object is on one side of and relatively far from the coil system. This makes the DC and RF fields at the mine relatively weak and nonuniform, resulting in poor detection efficiency for the signal from the sample. The net result is a sharp decrease in S/N ratio, requiring much larger magnets and more RF power. Such a system certainly would not be man portable but might be carried on a vehicle. Nevertheless, Burnett studied remote detection of explosives using hydrogen NMR [49], [50] and concluded that it is feasible with usable penetration depths and adequate S/N. He stated that NMR remote detection of explosives is possible. As an example, a system producing a uniform DC field of 1000 Gauss on 6.6×10^{22} protons (roughly equivalent to 23 g of TNT) at 10 cm distance would have a S/N of very roughly 10. NMR data on explosive compounds are sketchy and much more is needed. Field strengths of the above size require typically 100,000 Amp-turns and thus advanced NMR remote detection will require superconducting coils to

get the necessary S/N. The preferred configuration to achieve the necessary field strength and uniformity is an "inside-out Helmholtz" coil pair for the DC magnetic field and a semi-toroidal RF coil. As for more conventional NMR, it may also be possible to get a unique signal for each explosive using hydrogen/nitrogen level crossing or alternatively by using a spin echo pulse method to measure T_2 . King and colleagues constructed a crude prototype mine detector which was capable of detecting a 15 cm long, 15 cm diameter cylinder filled with RDX simulant at a maximum standoff of 7.5 cm [47]. They also found that up to 2.5 cm of soil cover had no effect on detection ability.

NQR involves the interaction of a nuclear quadrupole moment, such as that of ^{14}N , with the electric field gradient of the crystal in which it is imbedded. No external magnetic field is necessary. RDX, TNT and possibly PETN contain nitrogen and are solids possessing the necessary field gradient. The sensitivity is about ten times less than for NMR. Techniques are similar to NMR except that no magnetic field is necessary. Hydrogen NMR and nitrogen NQR might be combined [1], [2] to reduce the measurement time delay for NMR due to the long T_1 .

EPR is similar to NMR except that the magnetic field interacts with free electrons rather than the nuclear dipole. The resonance frequency is roughly 2000 times higher than NMR for the same DC field strength. Because of the need for free electrons, EPR can only be used for black powder and smokeless powder [51]. The former yields a strong EPR signal, while the latter yields a moderate EPR signal. NMR is very insensitive to the black powder.

In summary, hydrogen NMR is the best RRAS method for detection of all non-metallic cased munitions except black powder IED. For the latter, EPR should be used. The two techniques could be readily combined using the same magnetic field. Because of the requirement for RF radiation to interact with the atoms of the explosives, the explosives must not be enclosed in a highly conductive package such as metal. This makes NMR useless for detection of metal encased IED or as a verifier for detection of metallic munitions.

Nuclear Radiation Methods

Since the 1940's, research has been directed toward nuclear detection of explosives. This includes a substantial effort in forensics, such as analysis of blast scene residues and trace quantities of explosives on humans, but we are interested only in the research aimed at detection of munitions. The main thrusts in this area are currently the automatic detection of IED in baggage and detection of nonmetallic land mines. Nuclear techniques look at a characteristic return radiation or an intensity change of a noncharacteristic

scattered radiation. All things being equal characteristic radiation techniques are preferred, since noncharacteristic radiation methods are essentially void detectors, that is, they detect inhomogeneities in the medium and inclusions in addition to munitions. A common method is to base detection on a difference in atomic number, Z , between the explosives and background materials [1], [2]. This works for explosives in soil since the effective Z of soil is quite different from that of explosives. For example, gamma ray backscatter can distinguish between nonmetallic mines and soil and can also detect soil disturbances and voids. Organic materials, however, have an effective Z which is close to that of many explosives and thus cause false alarms.

There are a huge number of possible nuclear reactions that could be considered for explosives detection but for physical reasons such as lack of penetration of certain radiation types, lack of selectivity to explosives, etc., most can be discarded from further consideration.

Detection of IED

For detection of IED in airline baggage, the USA Federal Aviation Administration (FAA) has decided that only thermal neutron activation (TNA), fast neutron activation (FNA, also called neutron inelastic scattering gamma rays), and the associated particle technique hold any promise. Photoactivation and nuclear resonance absorption were considered and, although research is sponsored by the FAA, both are considered highly speculative for IED detection. Photoactivation involves using a high intensity and energy bremsstrahlung source to produce short lived isotopes in the explosives by (γ, n) , $(\gamma, 2n)$ or (γ, p) reactions. The isotopes decay by positron emission. Coincidence detection of subsequent 511 KeV positron annihilation gamma rays can be used to image the isotopes in the same manner as medical positron emission tomography. However, the high rate of product neutrons causes damage to film, magnetic tape and produces induced activities [52], [53]. Nuclear resonance absorption involves irradiating an object with high intensity gamma rays at a specific energy for which an isotope found in explosives has a resonance in its cross section. Such an isotope has been found in explosives [53]. Present research is still at a very early stage, investigating sources, detectors, efficiencies, expected count rates, etc. We will discuss the three more promising methods and will also include dual energy photon imaging [54], [55].

The most mature method for detection of bulk explosives to date is TNA (also called neutron capture gamma ray analysis) which detects a characteristic gamma ray from the (n, γ) reaction on nitrogen. A thermal neutron is captured by a ^{14}N nucleus, which changes to an excited ^{15}N nucleus and emits

characteristic gamma rays (Fig. 21). In baggage inspection, interference from chromium, chlorine and nickel gamma rays occurs, while in mine detection role, a 10.6 MeV silicon gamma from soil causes interference. The intensity of these interfering rays is usually small compared to that of the nitrogen 10.8 MeV gamma ray and can be compensated (Fig. 22). Inorganic scintillator detectors such as NaI(Tl), which have high sensitivity but low energy resolution, can be used. Although the source could be an electronic neutron generator, such as a deuteron/triton or D-T particle accelerator (typically producing 10^9 - 10^{10} neutrons/second at 14 MeV), it is usually more convenient to use a radioisotopic source such as ^{252}Cf . The neutrons are either thermalized in the source or in the explosives or barrier between source and explosives. The method is well suited to the automated detection of IED in airport baggage and currently is the nuclear method of choice for that role [56]. TNA systems have been comprehensively airport tested [53] and a TNA system, manufactured by SAIC (Science Applications International Corp, Santa Clara, CA, USA) is being installed at six international airports [57]. It can detect all types of modern explosives, including Semtex which is almost undetectable by trace gas analysis or X-ray inspection. Detection success rates of 90 - 96% and false alarm rates of from 1 - 8% are achievable [58]. Inspection rates of 600 bags per hour have been achieved and detections are automatic, requiring no operator interpretation. The system, which is the size of a small truck and weighs about 9000 kg, costs between \$750,000 and \$950,000 per unit. The TNA baggage inspection system employs an array of up to 80 small detectors grouped in two "C" shaped rings around the neutron source to produce a low spatial resolution image to aid in reducing false alarms.

It should be noted that TNA was developed in the early to mid 1980's under the specification that it be able to detect the minimum amount of explosives capable of bringing down a jetliner. Recent evidence from the wreckage of Pan Am Flight 103 suggests that the plane was destroyed by a much smaller amount of explosives than was previously thought possible [54]. TNA sensitivity could be increased, but the false alarm rate would rise as well, possibly as high as 25% or higher. A possible way around this would be to back up TNA with advanced energetic photon imaging systems. The most mature of these is a system called XENIS (X-ray Enhanced Interrogation System), consisting of a dual view X-ray imager, image processor and computer, which can combine low resolution TNA images with high spatial resolution X-ray images to produce a single image. The combined system has, like the TNA system, been extensively tested in a real airport environment and has reduced TNA false alarm rates by as much as 50% [52].

Even more advanced energetic photon imaging systems are based on

dual energy photons, the technology for which has been known in the medical field for about two decades. Monoenergetic photon absorption directly measures the line integral along the incident photon beam direction of the linear absorption coefficient μ . At low gamma ray (or X-ray) energies, μ is a function of average atomic number Z of the scattering material, average electron density¹, and the incident photon energy E . Absorption coefficient alone is insufficient to distinguish explosives from other materials. By using two photon energies, one can use the two values of the linear absorption coefficient to solve for ρ and Z . These parameters individually cannot be used to uniquely distinguish explosives from other materials, since for example, organic materials and explosives have quite similar effective Z but the two together provide a better discriminant. (From the viewpoint of pattern classification, this has the effect of making the degenerate 1-D feature space based on absorption coefficient, a 2-D space based on density and atomic number. Since these two quantities are largely uncorrelated, this greatly reduces the false alarm rate.) The commercially available Hi-Mat X-ray system (Heimann Systems Co., Iselin, NJ, USA) [54] scans a bag using an X-ray beam collimated to 2.5 cm. Two silicon detectors, one looking for X-ray attenuation by low Z materials and one looking for attenuation by high Z materials, form a composite coloured image of the line integral of Z . Low Z materials, such as organic materials and explosives, appear as one colour, high Z materials such as metals, are another colour and mixtures of these materials appear as a third colour.

Dual energy computed tomography (CT) is an even more sophisticated dual energy photon imaging method. The method produces a set of two dimensional image "slices" through the luggage in the same manner as conventional CT, except that two images are obtained for each slice at two different gamma ray energies. One now solves for ρ and Z from the two values of μ on a pixel by pixel basis. In experiments on baggage detection [55], it was found that most normal baggage items could be distinguished from explosives, although distinguishing one particular explosive (DuPont Tovex) from cheese was very difficult. Because a CT scan must be performed, the method may be quite slow compared to TNA.

FNA [53] involves detecting characteristic gamma rays from the inelastic scattering of fast neutrons by carbon, nitrogen and oxygen. The method of detection and imaging is otherwise identical to TNA. FNA has advantages, in principle, over TNA. The neutrons react with nitrogen, carbon and oxygen.

¹Electron density is proportional to $\rho Z/A$ where ρ is the mass density and A is the atomic mass. Most materials commonly encountered in munition detection, including explosives, have Z values between 2 and 20 and in this range, Z/A varies by only a few percent. Thus we can consider electron density and mass density to be equivalent to within a scaling constant.

The selectivity between explosives and other materials is in principle better than TNA because only explosives contain high densities of nitrogen and oxygen and low densities of carbon [54]. Because the peak neutron intensity is lower than TNA, less shielding is required. In theory, increased sensitivity is expected because of the higher interaction rate of fast neutrons [53], although in practice thus far S/N ratios have been low. However, a D-T generator is necessary as opposed to the much simpler *Cf* source. Production in the detector scintillator, by high energy neutrons, of a continuous gamma ray spectrum with associated pulse pile-up is one reason why S/N ratios are lower than theory suggests. The potential for success of this method has improved over the past few years and some say it is moving closer to proof of practicality [52] but FAA funding recently has been diverted to a similar project using pulsed neutrons [54].

Although FNA is at present much inferior to TNA, the ultimate hope for FNA is in a method called the associated particle technique. In this method, the D-T neutron generator is operated at low deuteron energy at which the neutron and alpha particle (formed by the deuteron/tritium collision) are emitted 180° from one another. The position and angle of the alpha particle is measured by a detector to determine the direction of the neutron which together with the measured arrival time of the detected gamma ray, yields the neutron interaction position. This then allows a 1 sided 3-dimensional image to be formed. A demonstration of 3 dimensional imaging of the elemental composition of extended objects, including explosives was planned for late 1988 [53], but to date there is no word of the outcome. Sensitivity must be improved by roughly two orders of magnitude to be practical for baggage scanning. Currently, the method can form an image in several minutes whereas inspection times of a few seconds are required [52]. An additional drawback is that, because of the need for a particle accelerator, instrument costs could be more than \$1,000,000 US.

Detection of Nonmetallic Landmines

Mine detection is a much more difficult problem than baggage inspection. The expected count rate is much lower due to the strong absorption of radiation by the soil overburden and the increased source/mine/detector distance. Also, the geometry requires backscatter detection which makes imaging more difficult. Nuclear techniques for nonmetallic mine detection can also be applied to metallic mine detection. The metal case will act as a barrier, somewhat reducing count rates and possibly adding some backscatter interference. Also, conventional metallic detection technologies such as magnetometers or

pulse induction are far better for metallic mine detection than nuclear methods. Thus, in what follows, we will mainly consider detection of nonmetallic mines.

The information on nuclear methods for mine detection in our early review of ordnance detection [1], [2] was largely based on a 1974 Workshop sponsored by US Army Belvoir Research and Development Center [41]. A large number of reaction types were analysed with respect to selectivity and sensitivity, false alarm rate, soil absorption, time to make a detection, present and future availability of sources and detectors and limitations due to fundamental physics. At that time, it was felt that nuclear detection of nonmetallic mines was at best marginally feasible. Only X-ray backscatter imaging was thought to be favourable for scanning (that is, rapid detection of mines). Thermal neutron capture gamma rays and neutron activation gamma rays were deemed to have a "tolerable" degree of feasibility, but only for the much slower role of verification of a detection.

In 1985, a Workshop was convened to reassess the results of the 1974 Workshop [59]. Three major advances had been made in the interim which it was felt might change the previous conclusions. These are the development of

1. a high intensity, linear scanning X-ray source with a 3 meter scan range (intended for medical use),
2. miniature 14 MeV electronic neutron generators with high outputs and
3. portable high computational power computers.

In light of this, the Workshop decided that the methods with the most promise were, in decreasing order of likelihood of success, X-ray backscatter imaging, thermal neutron capture gamma rays, neutron thermalization and differential collimated photon scattering. We will now briefly discuss each method.

Photon backscatter involves irradiating a nonmetallic mine and surroundings with a source of photons (X-rays or gamma rays) whose energy is less than 1 MeV. There is a high energy and a low energy peak in the spectrum of backscattered photons, the ratio of which can be used to determine presence of bulk explosives in soil [41]. Initial efforts toward photon backscatter detection of shallow nonmetallic land mines met with limited success. The chief problem was that the technique was based on a rate change which made results quite sensitive to detector/source height and amount of vegetation. Multiple gamma ray energies and the use of imaging could, in principle, alleviate these problems. Recently, researchers have begun to investigate X-ray backscatter radiography (imaging) for this role [60]. A schematic system for

a vehicle mounted X-ray backscatter mine detection is shown in Fig. 23. A pencil beam of X-rays is vertically incident on the soil surface. The beam is raster scanned across the soil surface and a two dimensional image is built up by forward vehicular motion orthogonal to the raster direction. Photons are absorbed and scattered by the soil but some penetrate to the mine, where they are scattered. Some of the scattered photons reach the panels of detectors after single or multiple scattering. Experiments involving raster scanning of an X-ray source and a small sodium iodide detector over a simulated mine in a soil box were used to verify a Monte Carlo photon transport model. The model was used in turn to study the practical problem in which large detectors are employed. Environmental factors were investigated, mine detection mechanisms were suggested, geometric parameters were optimized and power requirements were addressed. The study recommended a system using an X-ray generator rastered at a high scan rate, emitting a 1.5 cm diameter beam roughly perpendicular to the ground, and large panels of detectors in a plane parallel to the ground. The detectors would be collimated to emphasize the differences in multiple scattering components characteristic of soil and mine explosives. Such a system, it was felt, should be able to detect a buried nonmetallic anti-tank mine at 7.5 cm depth. It could be "portable" and would meet mine detection operational requirements (see [59]) for path width, speed, false alarm rate, etc. Images of holes refilled with loose dirt could be distinguished from buried mines, but looked similar to surface-laid mines. A compound detector with collimated and uncollimated regions could overcome this. Height sensitivity is a serious problem, even with imaging, but signal processing may solve it by correlating features of individual scan lines (high scan rates make height variation over a single scan line negligible). It should be noted that the recent mine detection study [59] determined that "the potential for development of a multiple energy scanning X-ray source producing real-time images [of nonmetallic mines] is high".

Thermal neutron capture gamma ray analysis is now deemed to have a moderate potential for success. The biggest change since the 1974 study has been the improvement in the ability of high efficiency gamma ray detectors such as NaI and BGO to handle detection rates 4 to 5 times higher than was previously possible.

Neutron thermalization was deemed to have a low potential for success in mine detection. Differential collimated photon scattering, which is an extension of multiple energy X-ray backscatter, could, if successful, eliminate the problems with X-ray backscatter. It is considered technologically a high risk because no prior experiments can be extrapolated to estimate the probability of success.

Not recommended by the Workshop, but which should not be entirely ruled out, is a technique dubbed mine detection by energetic photons (MIDEP), which is really just photoactivation in a mine detection role. Photoactivation was dismissed by the 1974 mine detection Workshop [41], because it was concentrating on short lived decay isotopes such ^{12}N from the $^{14}\text{N}(\gamma, 2n)^{12}\text{N}$ reaction, for rapid scanning. This required 30 MeV linear accelerators (linacs) which were impractical for the role and, together with background interference from soil materials, made the method unfeasible. Recent investigation has looked at the $^{14}\text{N}(\gamma, n)^{13}\text{N}$ reaction, whose end product decays by positron emission with a 10 minute half-life. Although slow, by increasing the activation rate, reasonable count rates could be achieved. Further, the photoneutron threshold for the reaction is 10.5 MeV which is below that of the soil constituents, which hence produce no background interference. In numerical simulation (Monte Carlo) studies [61], 5 kg of ammonium nitrate under 5 cm of soil (density 1.5 g/cm³) produced an effective signal to noise ratio of 10 for an energy expenditure of roughly 10 kJ/m². (This assumed a 14 MeV electron energy for the linac source, a 20 cm² active area NaI(Tl) detector 30 cm above the ground, a 0.2 s counting interval 2-3 s after irradiation.) The technique has been demonstrated in a small-scale proof-of-principle experiment at Lawrence Livermore Labs [61]. A linac operating at 14 MeV bombarded a block of melamine (simulating a high explosive). The melamine was detected while there was negligible signal from sand and peat. Practicality is still not certain as an analysis of problem configurations must still be done.

Finally, we should mention direct detection of photoneutrons from the (γ, n) reactions on ^{14}N (threshold 10.5 MeV) and ^{15}N (10.8 MeV). These were rejected by the 1974 and 1985 Workshops because of interference by low energy neutrons from the (γ, n) reactions on ^{29}Si (8.5 MeV) and ^{30}Si (10.6 MeV) [41]. Neutron spectroscopy using these reactions was dismissed because of the numerous high energy neutrons from ^2H (large abundance, large cross section, low threshold). Some of these would be scattered to low energy, interfering with those from the nitrogen reactions. This would be almost impossible to resolve if very low resolution proton recoil counters were used as suggested by [41]. Since that time, high energy resolution ^3He neutron spectrometers have been developed which might be able to resolve the components of the neutron spectra. This was suggested in our previous reviews [1], [2] but to our knowledge has not been followed up.

Trace Gas Analysis

Trace gas analysis, often called vapour detection or “sniffing”, involves sensing vapour emanating from the buried mine and then separating the constituent molecules, atoms or ions for identification. A viable method must have sufficient sensitivity to explosives vapours, sufficient selectivity to reject gases from naturally occurring materials, and operate in real-time or near real-time. Trace gas detection is particularly useful for personnel inspection, where even moderate radiation levels are often considered unacceptable. Common explosives and the component vapours associated with them are listed in Table 5 [62].

One first needs to understand how explosive vapours are transported from the munition to the detector. By way of an example, this is shown schematically in Fig. 24 for a buried nonmetallic mine. The vapour concentration immediately surrounding the explosives (shown for TNT) is reduced by at least a factor of million by the time the vapour reaches the detector. Vapour losses are a function of the types of case and embedding material and moisture content and there is a wide variation in the estimates of the magnitudes of the loss mechanisms [1], [2]. Thus, it is difficult to say exactly what is the minimum sensitivity necessary for a viable trace gas munition detector. A crude upper limit on the minimum sensitivity acceptable for IED detection can be set at 1 ng/m^3 since this is concentration of TNT vapour in room air produced by 500 g of TNT double wrapped in polyethylene sitting in a room for one hour (assuming the room air is well circulated) [63]. This is about 10^5 times lower than what would be expected from the vapour pressure alone due to the polyethylene barrier, adsorption on the walls and ventilation. For shallowly buried nonmetallic mines, the hermetically sealed case and soil overburden reduce this limit substantially. A sensitivity of at least 10^{-1} to 10^{-2} ng/m^3 is likely necessary [2].

The four most viable trace gas techniques for real-time detection of explosives vapours are mass spectrometry, ion mobility spectrometry, and laser/optical techniques. Further information on these techniques is found in [1], [2]. Other techniques, such as solid state detectors (resistive film, MOSFET), differential Raman spectroscopy, photothermal deflection spectroscopy and gas chromatography, are far too insensitive or lack selectivity.

The most sensitive of these methods is atmospheric source mass spectrometry and of these the most sensitive is atmospheric pressure chemical ionization mass spectrometry (APCI MS). This is shown schematically in Fig. 25. Various equilibrium reactant ions are shown in the reaction chamber as well as the major product ion $(M - 1)^+$ (M is the trace molecule of interest such

as TNT). APCI and other atmospheric source MS rely on the fact that organic explosives molecules, in contrast to other compounds in nature, readily form negative ions. This suppresses background interference by several orders of magnitude even before mass selection is attempted. The velocity selector and magnetic field, B , select ions of a specific mass whose relative abundance may be measured. Commercial versions of APCI MS exist. One version is the TAGA mass spectrometer (Sciex Ltd., Toronto, Canada) [1], [2], which is capable of detecting TNT at levels of 0.5 ng/m^3 and DNT, an impurity of TNT (Table 5), at levels of 0.06 ng/m^3 . There are no memory effects and response time is a few milliseconds. The device can be contained in a small van. Another version of atmospheric source MS, which may be applicable to explosives detection is a variant of the tandem mass spectrometer (MS/MS). Oak Ridge National Labs (USA) has been researching MS/MS for explosives detection for several years. In their system, parent ions from the explosives molecules and some interference ions are formed by an atmospheric sampling glow discharge ionization source. The parent ions are selected by passing through a quadrupole mass analyser and into a collision chamber where daughter ions are formed. These then pass through a time-of-flight mass analyser and are detected by an ion trap [64]. The instrument is very flexible, being able to operate in a number of different modes which trade off selectivity against sensitivity. Sensitivity to RDX ranges from 3 ng/m^3 to 300 ng/m^3 , depending on the mode of operation [65]. A new mode, dubbed targeted daughter ion MS/MS mode, may allow further increases in sensitivity, but it is uncertain whether there will be sufficient selectivity.

Ion mobility spectrometers (IMS), which were formerly called plasma chromatographs, are the next most sensitive trace gas detectors. They are capable of detecting approximately 100 ng/m^3 of TNT and 20 ng/m^3 of Ethylene Glycol Dinitrate (EGDN), although potential for improvement exists. An ion mobility spectrometer is shown schematically in Fig. 26. Ions are formed by the interaction of the trace gas and carrier gas with an ionization source (here a ^{63}Ni source) in the ion drift reactor. The ions are injected as a pulse by the grid into the ion drift spectrometer and drift against the flow of a drift gas. For fixed conditions, each ion has a specific drift rate which may be used to identify it. The relative abundance of each ion may be measured. One chief problem is interference by nontarget molecules. This can be alleviated by subtracting background spectra taken in an environment free of the target and by collecting both positive and negative ion spectra. A number of companies manufacture ion mobility spectrometers, although not specifically for explosives detection. The detectors may be made handheld, such as the Graseby Dynamics CAM (U.K.), but miniaturization leads to a loss of sensitivity

compared to the above quoted values.

The most promising laser/optical techniques as identified by a 1983 Federal Aviation Administration Workshop [5] include:

1. laser multiphoton ionization - based on detection of small molecular fragments or daughter molecules, produced by laser excitation,
2. chemiluminescence - based on the $NO + O_3 \rightarrow NO_2^*$ reaction,
3. photoacoustic (optoacoustic) absorption cells and
4. multipath cell/diode laser systems.

The first method is deemed to be too elaborate, while the second is not sufficiently sensitive. The last two achieve specificity by relying on selective absorption by a vibrational spectral line in the target molecule.

Photoacoustic absorption has achieved sensitivities for certain simple molecules as good as 300 ng/m^3 . The method is shown schematically in Fig. 27. A high power infrared laser is tuned to a strong absorption line or group of lines characteristic of the trace gas of interest. When the gas is present in the absorption cell, it absorbs the radiation, producing localized heating. This in turn produces an acoustic pulse which may be detected by a sensitive microphone. The biggest problem is interference from naturally occurring unwanted molecular species due to the relatively broad line widths of the lasers which must be used. Variants, such as Zeeman modulated optoacoustics may ultimately be capable of sensitivities to some explosives as good as 10 ng/m^3 [5].

The multipath cell/diode laser system can be tuned to much narrower lines which greatly improves sensitivity. Such a detector is shown schematically in Fig. 28. The diode laser is tuned to a strong absorption line for the molecule of interest and the change in current at the detector when the trace gas is pumped into the cell, serves to determine how much gas is present. SO_2 can be detected at a level of 1000 ng/m^3 and NH_3 (very strong absorption line) at 40 ng/m^3 . (For comparison, the human nose can detect SO_2 in air at levels of 0.012 g/m^3 and NH_3 at 0.004 g/m^3 [66]. Explosives molecules are much more complex than these simple molecules and may not have the necessary narrow absorption line or feature (such as a strong Q branch).

Although the sensitivity estimates for detection of explosives by photoacoustic absorption have improved somewhat, the overall assessment of the potential of laser/optical methods has not changed significantly since 1981 [1], [2]. The sensitivities are substantially less than APCI mass spectrometry

and, barring the unlikely event of a very strong absorption line for certain explosives, less than ion mobility spectrometry.

All trace gas detectors can be used with preconcentrators, which essentially act as gain amplifiers, and extensive work has been done on the subject. There are two basic types - scrubbers and absorbers. It has been estimated [67] that a theoretical concentration improvement of between 10^2 and 10^4 is possible using preconcentrators. In practice, however, the limit is usually lower and there is a measurement time / gain tradeoff. Membrane preconcentrators, for example, have achieved 50-fold concentration enhancements [68] but required 200 minutes to achieve this level.

Based on the required sensitivities mentioned at the beginning of this section (1 ng/m^3 for IED, 0.1 to 0.01 ng/m^3 for mines), we see that at present APCI MS is suitable for IED detection with or without a preconcentrator. APCI MS is the only trace gas technology which is feasible for nonmetallic mine detection, being marginally feasible without a preconcentrator, and likely feasible with a preconcentrator. Atmospheric source MS/MS is marginally feasible for IED detection without a preconcentrator and feasible with one. Ion mobility spectrometry is feasible for IED detection with a preconcentrator. Laser / optical techniques are likely not feasible for IED detection. Improvements in sensitivity and reduction in size are possible for all technologies. Nonmetallic mine detection has added difficulties. Inability to localize a mine due to drifting of the explosives plume may be a serious problem and lingering explosives vapours in a battlefield environment might render trace gas analysis ineffective for mine detection in practice.

Biochemical Detection

Detection of an item using biological systems is called biological detection or biodetection. Some member technologies should really be included under Methods Which Do Not Detect Explosives Directly. One example, which is somewhat far-fetched, is magnetotactic bacteria [1]. A group of technologies which does involve direct detection of explosives, biochemical detection, shows some potential for munitions detection. Biochemical detection is really a trace gas detection method which uses chemical processes associated with biological systems. Olfaction, a biochemical detection method, can respond in some cases to as little as a few tens of molecules of certain chemicals. This clearly makes it the most sensitive trace gas detection method. Biochemical detection can be divided into two general classes - *in vivo* and *in vitro*.

Until the late 1970's, most research centered on *in vivo* detectors such as mammalian olfaction and bioluminescent bacteria [1], [2]. Animals are still

the best explosives vapour detectors. Dogs are routinely used in the field for IED and drug detection and they have been used with some success for nonmetallic mine detection [69]. Dogs can detect roughly 300 g of explosives simulatant buried 15 to 30 cm under soil with a confidence level of between 80 and 96% [2]. However, burial times of a few months, environmental factors, crowds and noise can render them ineffective. In recent years, researchers have concentrated on small rodents, such as rats, as a replacement for canines [70]. Rodents are at least as sensitive and selective as canines, and rats may be as easily trained. Rats are small and cheap compared to dogs and can be put into a small detector box. The rat is trained to press a touch bar when it smells explosives.

It must be noted, however, that the mechanism for mammalian olfactory detection of explosives is still not well understood, and few experiments have produced quantitative sensitivity limits. In fact, there has been considerable debate over whether dogs smell explosives vapours emanating from inside a mine, or vapours from trace explosives contamination on the mine surface, or whether they detect soil disturbances. Recent experiments [71] have shown that rats can successfully detect 2000 to 3000 ng/m³ of TNT 96% of the time with a 1% false alarm rate. This is at least a factor of 1000 less sensitive than APCI MS, in spite of mine detection studies which indicate that mammalian olfactory detection is far more sensitive than explosives detection using man-made trace gas detectors. The authors are unaware of a resolution to this contradiction and suggest that further experiments are required.

It has been known for some time that certain explosives vapours, such as TNT, alter the light output of bioluminescent bacteria. A schematic diagram of the interaction of explosives molecules with the bioluminescence reaction chain is presented in Fig. 29. The enzyme luciferase catalyses the oxidation of luciferin into excited oxyluciferin. The enzyme achieves this by modifying production of an intermediate molecule NADH (reduced nicotinamide adenine dinucleotide). The excited oxyluciferin de-excites, emitting light. Explosives molecules inhibit the luciferase enzyme and thus the amount of light emission depends on the concentration of explosive present. Experiments by the U.S. MERADCOM in the 1970's could not breed bacteria that were sufficiently sensitive to or selective for explosives to fulfill a mine detection role. Consequently, most of the recent research in biochemical detection has centered on transferring the biochemical systems that detect explosives in live bacterial cultures into an *in vitro* system.

The two leading candidates [72] are enzymatic TNT detection and light emission immunoassay. In the former, a TNT-specific enzyme (TNT-reductase) catalyzes a two-step reaction which reduces a TNT molecule to a

hydroxylamine molecule (Fig. 30). In the process two molecules of NADH are consumed by the TNT-reductase. NADH concentration is measured by a light emitting indicator reaction, derived from the bacterial luciferase reaction mentioned previously (Fig. 30). Light emission, which can be measured with high sensitivity using a photomultiplier, is a function of the NADH concentration which is in turn a function of the TNT concentration. Amounts of TNT as low as 4.5×10^{-3} ng can be detected in the liquid phase. Unfortunately, oxidation of 90% of the available NADH by TNT-reductase occurs independently of the TNT concentration.

Light emission immunoassay employs the powerful techniques similar to those of enzyme linked immunosorbant assay (ELISA) used in biomedical research. Free TNT molecules and TNP-luciferase molecules, which consist of luciferase linked to a TNP (trinitrophenal) antigen, are placed together in solution for a period of time, typically an hour (Fig. 31). Because of similarities in the structure of TNT and TNP, the TNT and TNP-luciferase molecules compete to bind to sites on TNP antibodies which have been immobilized to a solid. Excess TNT and TNP-luciferase are then washed away. The remaining TNP-luciferase which is bound to the antibodies then catalyzes a light emitting reaction and the light is detected by a photomultiplier. The amount of bound TNP-luciferase, and hence the amount of light emitted, is a function of the free TNT concentration. Amounts of TNT as low as 1.1×10^{-2} ng can be detected. A variant which uses TNT-glucose-6-phosphate dehydrogenase catalyzes NADH formation at a higher rate and can detect amounts of TNT as low as 2×10^{-6} ng. Such sensitivities are sufficient for nonmetallic mine detection, but the present assay techniques involve wet chemistry and are not done in real-time (typically a few hours). The U.S. has a program to develop fiber-optic sensors as probes to detect trace quantities of materials, including explosives [73]. The detection system under development involves attaching a high density of antibodies to an optical fiber. Methods must be sought to immobilize the antibody while retaining the antibody's ability to bind to the antigen. This research is still very much in the formative stage. Light emission immunoassay is currently an off-line process and it remains to be seen whether it can be adapted to on-line or real-time use.

All the biochemicals mentioned above are currently obtained from bacterial cultures by fermentation. Recombinant DNA technology, such as the use of monoclonal antibodies, could allow much cheaper and more efficient production.

CONCLUSION

A review of the state-of-the-art in detection of hidden explosive munitions, namely buried unexploded ordnance (UXO), buried mines and improvised explosive devices (IED), has been presented. Technologies have been divided into those that detect explosives directly and those that do not. For each technology, the physical principles, methodologies, strengths and weaknesses and probability of success has been discussed. Technologies that do not detect explosives include magnetostatics, electromagnetic induction, impedance tomography, electromagnetic radar, acoustics and optics. Those that detect explosives include radiofrequency resonance absorption, nuclear radiation methods, trace gas detection and biochemical detection.

"Smart" magnetometers and electromagnetic induction are relatively cheap, robust, have good penetration in soil and are very well suited for the location and identification of ferrous and metallic cased munitions at short distances (up to 2m). They should be the methods of choice for detection of metallic munitions. Prototype instruments which locate and identify metal-encased mines have been demonstrated in the laboratory, but further work is needed to make them fieldable.

The remaining methods should be considered for detection of nonmetallic munitions or verification of detection of metallic munitions.

Electrical impedance tomography or conductivity imaging shows some potential to identify hidden conductive objects but at present images are crude and computer time is excessive. These are not limitations due to fundamental physics and work on algorithm refinement may eventually solve them. The role of impedance tomography would likely be detection of nonmetallic mines and verification of mine or UXO detections.

Ground probing radar (GPR) systems exist which are sensitive enough to detect nonmetallic mines but false alarm rates are very high. Advanced processing systems employing imaging and/or clutter reduction will be required if GPR is to be viable for this role. Substantial additional research will be required to determine if this is possible.

Acoustic detection is not likely to be useful due to the inhomogeneity of

the media which hide the explosives, such as soil, baggage containers or luggage items. Multimode propagation further complicates analysis. For acoustics to succeed, the munition must be imaged. Although it may be possible to reliably image very shallowly buried mines, no published evidence of this is available. Imaging of more deeply buried mines or other munitions may be possible, although not in the near future, by extending the electrical impedance tomography algorithms mentioned above.

Optical techniques are not practical for detection of hidden munitions, including freshly buried mines. Thermal infrared detection suffers from severe false alarm problems and measurements can be made only at specific times of day. Protein fluorescence yields very weak signals.

Nuclear magnetic resonance (NMR) can detect buried or hidden explosives if their containers are nonmetallic. Hydrogen NMR is the best choice for all explosives except black powder for which electron spin resonance should be used and the two methods can be combined. Prototype hydrogen NMR systems have been developed for scanning baggage and letters. The buried mine problem is much more difficult primarily due to the increased distance and poorer geometry. Such a system is possible, but much additional research is required.

Nuclear detection of explosives in baggage is feasible and neutron capture gamma ray baggage scanning systems have been installed in 6 major airports. It may well become the baggage scanning system of choice. The chief problem with nuclear detection of explosives in mines is the low count rate due to the soil overburden and the source/mine/detector distance. The method with the best potential for nonmetallic mine detection is X-ray backscatter imaging, but such systems do not yet exist and more experimental work is necessary.

At present APCI MS is suitable for IED detection with or without a preconcentrator. APCI MS is the only trace gas technology which may be feasible for nonmetallic mine detection. In this role it is at best marginally feasible without a preconcentrator. Atmospheric source tandem mass spectroscopy is marginally feasible for IED detection without a preconcentrator and feasible with one. Ion mobility spectrometry is feasible for IED detection with a preconcentrator. Laser / optical techniques are likely not feasible for IED detection. Improvements in sensitivity and reduction in size are possible for all technologies. Inability to localize a mine due to drifting of the explosives plume and lingering explosives vapours in a battlefield environment might render trace gas analysis ineffective for mine detection in practice.

Mammals are still the best explosives vapour detectors. Dogs are routinely used in the field for IED detection and have been used with some suc-

cess for mine detection. *In vitro* biochemical detectors based on liquid phase enzyme reactions and immunoassay techniques to explosives are the most sensitive chemical detection method for TNT, by one to five orders of magnitude and are sensitive enough to detect nonmetallic mines in principle. At present the assays are done in liquid solution and are not performed in real time. It is not clear whether the methods can be adapted to aerosol sampling and real-time applications.

Combining a number of methods may decrease the false alarm rate, although there will be an attendant increase in cost and complexity.

REFERENCES

- [1] J.E.McFee and Y.Das, "The detection of buried explosive objects", *Can J Remote Sens* 6, p.104, 1980.
- [2] J.E.McFee and Y.Das, "Review of unexploded ordnance detection methods (U)", *DRES Rept. 292*, Defence Research Establishment Suffield, Medicine Hat, AB, Canada, Sep 1981, UNCLASSIFIED.
- [3] J.E.McFee and Y.Das, "The state-of-the-art in detection of explosive munitions (U)", *invited paper, Proceedings of Fourteenth Meeting of TTCP Technical Panel WTP-1*, Waterways Experimental Station, Vicksburg, Miss, USA, Sep 24 1986, UNCLASSIFIED.
- [4] S.Oedman, "Mine detectors: a literature review 1989", *Rept. FOA-C-30545-3.1*, Foersvarets Forskningsanstalt, Linkoeping Sweden, Huvudavdelning foer informationsteknologi, Jan 1990.
- [5] "Chemical and electromagnetic methods for high explosive/ ordnance detection - Vol.1", *Rept. GC-TR-86-1536-VOL-1*, Geo-Centers Inc., Newton Upper Falls, MA, USA, AD-A176 630, Nov 1986.
- [6] "Chemical and electromagnetic methods for high explosive/ ordnance detection - Vol.2", *Rept. GC-TR-86-1536-VOL-2*, Geo-Centers Inc., Newton Upper Falls, MA, USA, AD-A176 631, Nov 1986.
- [7] J.E.McFee, "Electromagnetic remote sensing. Low frequency electromagnetics (U)", *DRES Rept. SP-124*, Defence Research Establishment Suffield, Jan 1989, UNCLASSIFIED.
- [8] W.Wynn, C.Frahm, P.Carroll, R.Clark, J. Wellhoner and M. Wynn, "Advanced superconducting gradiometer/magnetometer arrays and a novel signal processing technique", *IEEE Trans Mag MAG-11*, p.701, 1975.
- [9] J.E.McFee, Y.Das, "Fast nonrecursive method for estimating location and dipole moment components of a magnetic dipole", *IEEE Trans GeoSci and Rem Sens GE-24*, 1986.

- [10] J.T.Tou and R.C.Gonzalez, "Pattern Recognition Principles", *Addison-Wesley*, Reading MA, U.S.A., 1974.
- [11] J.McFee and Y.Das, "A classifier for feature vectors whose prototypes are a function of multiple continuous parameters", *IEEE Trans. Pattern Analysis and Machine Intelligence PAMI-10*, p.599, 1988.
- [12] J.McFee, Y.Das and R.Ellingson, "Locating and identifying compact ferrous objects", *IEEE Trans. GeoSci. Remote Sensing GE-28*, pp.182-193, 1990.
- [13] "Validation report surface towed ordnance locator system (STOLS)", *NAVEODTECHCEN Rept. TR-281*, Naval Explosive Ordnance Disposal Technical Center, Indian Head, MD, USA, Jan 1988.
- [14] J.McFee and Y.Das, "Determination of the parameters of a dipole by measurement of its magnetostatic field", *IEEE Trans. Antenna and Propagation AP-29*, p.282, 1981.
- [15] J.M.Stanley and M.K.Cattach, "An image processing magnetometer system for explosive ordnance detection", *private communication*, The Geophysical Research Institute, University of New England, Armisdale, N-SW, Australia.
- [16] Y.Das, J.Toews and J.E.McFee, "Vehicle-mounted ordnance locator : an experimental prototype (U)", *DRES Rept. 434*, Defence Research Establishment Suffield, Medicine Hat, AB, Canada, Feb 1988, UNCLASSIFIED.
- [17] Y.Das, J.McFee, J.Toews and G.Stuart, "Analysis of an electromagnetic detector for real-time location of buried objects", *IEEE Trans. GeoSci. Remote Sensing GE-28*, 278-288, 1990.
- [18] Y.Das, J.E.McFee and R.H.Chesney, "Determination of depth of shallowly buried objects by electromagnetic induction", *IEEE Trans GeoSci and Rem Sens GE-23*, p.60, 1985.
- [19] R.H.Chesney, Y.Das, J.E.McFee and M.Ito, "Identification of metallic spheroids by classification of their electromagnetic responses", *IEEE Trans Pattern Analysis and Machine Intelligence PAMI-6*, p.809, 1984.
- [20] K.A.Dines and R.J.Lytle, "Analysis of electrical conductivity imaging", *Geophysics 46*, p.1025, 1981.

- [21] L.R.Price, "Electrical impedance computed tomography", *IEEE Trans Nuc Sci NS-26*, p.2736, 1979.
- [22] A.Wexler,B.Fry and M.R.Neuman, "Impedance-computed tomography algorithm and system", *Applied Optics 24*, pp.3985-3992, 1985.
- [23] A.Wexler, "Electrical impedance imaging in two and three dimensions", *Proc 2nd EEC Workshop on Electrical Impedance Imaging*, Lyon, France, 21-23 Oct 1987. (Published in *Clinical Physics and Physiological Measurement Suppl.A*, pp.29-33, 1988.)
- [24] R.A.M.Allen and A.Wexler, "A study of impedance imaging of buried ordnance (U)", DRES Contract Rept. 4/89, DSS Contract File No. 01SG.97702-R-5-0748, Quantic Electroscan Inc., Winnipeg, MN, Canada, Jan 1989, UNCLASSIFIED.
- [25] Special Issue on Subsurface Radar, IEE Proceedings(F), Vol. 135, No. 4, Part F, Aug 1988.
- [26] Daniels, D.J., Gunton, D.J. and Scott, H.F., "Introduction to subsurface radar", *Special Issue on Subsurface Radar, IEE Proceedings(F), Vol. 135, Part F, No. 4*, pp.278 - 320, Aug 1988.
- [27] Chignell, R.J., Jackson, P.A. and Madani, K., "Early developments in ground-probing radar at ERA Technology Ltd.", *Special Issue on Subsurface Radar, IEE Proceedings(F), Vol. 135, Part F, No. 4*, pp.362 - 370, Aug 1988.
- [28] "Study of ground probing radar systems for detection of non-metallic mines (U)", DRES Contract Rept. 34/90, DSS Contract File No. W7702-9-R118/01-XSG, Interra Technologies Ltd., Calgary, AB, Canada, Mar 1990, UNCLASSIFIED.
- [29] Goodman, J.W., Huntly, W.H., Jackson, D.W. and Lehmann, M., "Wavefront-reconstruction imaging through random media", *Applied Physics Letters, Vol.8, No.12*, pp.311-313, Jun 1986.
- [30] Echard, J.D., Scheer, J.A., Rauch,E.O., Licata, W.H., Moor, J.R., and Nestor, J.A., "Radar detection, discrimination and classification of buried non-metallic mines, Vol.I", *Technical Rept. on Contract No.DAAG53-76-C-0112*, Georgia Institute of Technology, Engineering Experiment Station, Atlanta GA, 1978.

- [31] Johnson, C.N. and Gravitte, D.L., "Microwave radiometric studies in relation to mine detection", *Rept. 1875 on Project 1D624101A46101*, US Army Engineer Research and Development Lab., Fort Belvoir, VA, Nov 1966.
- [32] T.G.Winter, "A survey of sound in soil", *Acoustic Holography Vol.5*, P.S.Green (ed.), Plenum, New York, p.197, 1974.
- [33] D.Caulfield, "Laser optic-acoustic sensors and processing concepts for airport security services", *Technical Rept. 1502-4*, Caulfield Engineering Ltd., Edmonton, AB, Canada, 1989.
- [34] A.A.Morita, "Land mine detection system", *TRW Rept. AT-73-2*, TRW Systems Group, Redondo Beach, CA, USA, Feb 1973.
- [35] "A study of visible and infrared remote minefield detection", Final Rept., DSS Contract 8SG84-00092, Barringer Research, Toronto, ON, Canada, 1985, UNCLASSIFIED.
- [36] "Proceedings of the 1986 international geoscience and remote sensing symposium (IGARSS '86) on remote sensing: today's solutions for tomorrow's information needs. Volume 3.", eds.T. D. Guyenne, J. J. Hunt, Zurich, Switzerland, 8-11 Sep 1986; (NTIS Publication N87-18142 PC A21/MF A01).
- [37] "Explosives detection. January 1971-July 1989 (A bibliography from the compendex database", *National Technical Information Service*, Springfield, Va, USA, Mar 1990.
- [38] "Proceedings of the symposium on analysis and detection of explosives (3rd). Held in Mannheim-Neuostheim (FGR)", *Fraunhofer Inst. fuer Chemische Technolgie*, Berghausen, FGR, 10-13 Jul 1989.
- [39] "Techniques for the detection of explosives", *Rept. SAND-89-0677C*, Sandia National Labs, Albuquerque, NM, USA, 10 Jul 1989.
- [40] "Proceedings of the international symposium on the analysis and detection of explosives. Held at Quantico, VA, USA", *Rept. PC A21/MF A01*, Federal Bureau of Investigation, Washington, DC, USA, 29-31 Mar 1983.
- [41] W.A.Coleman, R.O.Ginaven and G.M.Reynolds, "Nuclear methods of mine detection", US Army Mobility Equipment Research and Development Center, Fort Belvoir, VA, USA, Rept. Under Contract DAAK02-73-C-0139, May 1974.

- [42] J.E.Powell and J.W.Matthews, "The detection of high explosives by capture gamma ray techniques", *Sandia Lab. Rept.*, Sandia Laboratories, Albuquerque, NM, USA, 1971.
- [43] W.L.Rollwitz, J.D.King and S.D.Shaw, "Determining the potential of radiofrequency resonance absorption detection of explosives hidden in airline luggage", *Southwest Research Institute Rept.*, AD-A022 111, 1975.
- [44] P.G.Morris, "Nuclear Magnetic Resonance Imaging in Medicine and Biology", *Clarendon Press*, Oxford, U.K., 1986.
- [45] J.D.King, W.L.Rollwitz and A.De Los Santos, "Applications of nuclear magnetic resonance to the detection and identification of explosives", *Proc New Concepts Symposium and Workshop on the Detection and Identification of Explosives*, sponsored by the U.S. Depts. of Treasury, Energy, Justice and Transportation, Reston, VA, USA, pp.391-398, Oct 30,31, Nov 1, 1978.
- [46] J.D.King, W.L.Rollwitz and A.De Los Santos, "Advances in magnetic resonance for the detection of bulk explosives", *Proc 1980 International Conference: Security Through Science and Engineering*, Technical University Berlin, FDR, p.181, Sep.23-26, 1980.
- [47] J.D.King, A. De Los Santos and W.L.Rollwitz, "Nuclear magnetic resonance techniques for explosives detection", *Southwest Research Institute Rept.*, San Antonio, TX, USA, AD-B026059, Feb 1977.
- [48] L.J.Burnett, "A study to review and evaluate customs nuclear magnetic resonance equipment and programs", *Final Rept. on U. S. Customs Contract TC-84-25*, Jan 1985.
- [49] L.J.Burnett and M.A.Fineman, "Evaluation of one-sided nuclear magnetic resonance for remote detection of explosives", *Rept. NOSC TD 1118*, Naval Oceans System Center, San Diego, CA, USA, AD-A184490, Jul 1987.
- [50] L.J.Burnett and M.A.Fineman, "Evaluation of one-sided nuclear magnetic resonance for remote detection of explosives", *Rept. NOSC TD 1169*, Naval Oceans System Center, San Diego, CA, USA, AD-A188169, Oct 1987.

- [51] W.L.Rollwitz, J.D.King and S.D.Shaw, "Determining the potential of radiofrequency resonance absorption detection of explosives hidden in baggage", *Rept. SWRI 15-4225*, Southwest Research Institute, San Antonio, TX, USA, AD-A022111, Oct 1975.
- [52] T.Gozani, C.Seher and R.E.Morgado, "Nuclear based explosive technique - 1989 status", *Proceedings of the 3rd symposium on analysis and detection of explosives, Mannheim-Neustheim (FGR)*, Fraunhofer Inst. fuer Chemische Technolgie, Berghausen, FGR, 10-13 Jul 1989.
- [53] R.E.Morgado, T.Gozani and C.Seher, "Detection of bulk explosives using nuclear-based techniques", *Proc International Congress on Applied Criminology*, Gent, Belgium, 29 Aug 1988.
- [54] E.E.Murphy, "A rising war on terrorists", *IEEE Spectrum*, pp.33-36, Nov 1989.
- [55] F.L.Roder, "Explosives detection using dual energy computed tomography", *SPIE 182*, p.171, 1979.
- [56] T.Gozani, P.Ryge, P.Shea, C.Seher, R.E.Morgado, "Explosive detection system based on thermal neutron activation", *IEEE Aerospace and Electronics Systems Magazine 4(12)*, pp.17-20, 1989.
- [57] D.Boyle, "Semtex detected: new sensor for airline baggage bombs", *International Defense Review 22(10)*, pp.1407-10, 1989.
- [58] C.C.Seher, "Airport tests of Federal Aviation Administration thermal neutron activation explosives detection systems", *Proceedings of the 3rd symposium on analysis and detection of explosives, Mannheim-Neustheim (FGR)*, Fraunhofer Inst. fuer Chemische Technolgie, Berghausen, FGR, 10-13 Jul 1989.
- [59] R.B.Moler, "Workshop report : Nuclear techniques for mine detection research, Lake Luzerne, NY, July 22-25, 1985", Army Belvoir Research and Development Center, Fort Belvoir, VA, USA, AD-A167968, Nov 1986.
- [60] J. G. Campbell, "Landmine detection by scatter radiation radiography", *Ph.D. Thesis* University of Florida, USA, AD-A182227, Jul 1987.
- [61] R.B.Miller, W.F.McCullough, K.Billman, C.Bowen "Background estimates for the MIDEP (mine detection with energetic photons) concept", *Rept. UCRL-21119* Lawrence Livermore National Labs, CA, USA, May 1988.

- [62] P.Del Markham, "The probe and other developments in explosives detection in Canada", *Committee on Aviation Security Rept. CAS 77/2*, National Research Council, Ottawa, Canada, 1977.
- [63] A.Brittain, Royal Armaments Research and Development Establishment, Fort Halstead, Sevenoaks, Kent, United Kingdom, private communication.
- [64] S.A.McLuckey, G.L.Glish and B.C.Grant, "Explosives detection using an ion trap mass spectrometer", *Proc International Symposium on Analysis and Detection of Explosives*, Mannheim, Germany, 10 Jul 1990.
- [65] F.J.Conrad, D.W.Hannum, B.C.Grant, S.A.McLuckey, H.S.McKown and G.L.Glish, "Evaluation of the the Oak Ridge MS/MS explosive detector", *Proceedings of the 3rd symposium on analysis and detection of explosives, Mannheim-Neuostheim (FGR)*, Fraunhofer Inst. fuer Chemische Technologie, Berghausen, FGR, 10-13 Jul 1989.
- [66] J.E.Amoore and E.Hautala, "Odour as an aid to chemical safety...", *J. Applied Toxicology Vol.3 No.6*, p.272, 1983.
- [67] W.Williams, F.Conrad, L.Sandlin and T.Burrows, "Progress in the development of explosives materials detectors", *Proc 19th Annual Meeting Inst of Nuc Materials Management, Vol 7*, p.431, Jun. 27-29 1978.
- [68] D.Armstrong, R.W.Baker and J.Mohr, "New membrane preconcentration devices for trace vapour detection systems Phase I (U)", *Final Report to US Army Belvoir Research and Development Center*, Membrane Technology and Research Inc., Menlo Park, CA, AD-A161 042, 1985, UNCLASSIFIED.
- [69] R.E.Lubow, "The War Animals", *Doubleday*, New York, 1977.
- [70] R.V.Nolan, "Explosives detection systems using behaviourally modified rats (U)", *US Army Mobility Equipment Research and Development Report*, AD-A117 293, 1982, UNCLASSIFIED.
- [71] S.Weinstein, R.Drozdenko and C.Weinstein, "Detection of extremely low concentrations of ultrapure TNT by rat", *Proceedings of the 3rd symposium on analysis and detection of explosives, Mannheim-Neuostheim (FGR)*, Fraunhofer Inst. fuer Chemische Technologie, Berghausen, FGR, 10-13 Jul 1989.

- [72] H.C.Egghart, "The MERADCOM *in vitro* biosensor program (U)", *US Army Mobility Equipment Research and Development Rept.*, AD-A127 766, 1982, UNCLASSIFIED.
- [73] F.S.Ligler, "Immunoassay procedures for fiber optic sensors", *Final Report.*, Naval Research Lab, Washington, DC, USA, AD-A203069, Apr 1988, UNCLASSIFIED.

Table 1

THREE CLASSES OF EXPLOSIVE MUNITIONS

CHARACTERISTIC	UXO	MINE	IED
NUMBER OF SHAPES	many	few	many
COMMON TYPES OF SHAPE	prolate spheroid, cone on cylinder	oblate spheroid, squat cylinder, irregular	various
SIZES	many	few	many
BACKGROUND CLUTTER DENSITY	metal: high explosive vapours: low	metal: low explosive vapours: moderate	sparse-moderate: depends on scenario/detector
TYPICAL DEPTH	0 to 10 meters	< 0.3 meter	various
CASE MATERIALS	metallic, mostly ferrous	metal, plastic, wood, no case	metal, plastic, wood, no case
CHIEF DETECTION PROBLEMS	high false alarms: must detect explosives	nonmetallic mines: must detect explosives	varied scenario must detect explosives
NEAR TERM SOLUTION	smart magnetometers & EMI detectors	metallic: same as UXO, nonmetallic: none	NMR, nuclear
LONG TERM SOLUTION	smart magnetometers, EMI detectors, GPR?, impedance tomography?	metallic: same as UXO, nonmetallic: NMR?, nuclear?	NMR, nuclear

Table 2
METHODS OF DETECTING EXPLOSIVE MUNITIONS

DO NOT DETECT EXPLOSIVES	DETECT EXPLOSIVES
<p>Magnetostatics Electromagnetic Induction Impedance Tomography Microwave Methods Acoustics Optical: - ultraviolet - visible - infrared active and passive Biological Detection</p>	<p>Radiofrequency Resonance Absorption: - nuclear magnetic resonance - nuclear quadrupole resonance - electron spin resonance Nuclear Detection: - thermal neutron capture gamma rays - x-ray backscatter imaging Trace Gas Detection - Biochemical Detection</p>

Table 3

PHYSICAL PROPERTIES OF EXPLOSIVES

MATERIAL	CHEMICAL FORMULA	MOLECULAR WEIGHT	DENSITY (g/cm ³)	COMPOSITION (%)					(WT %) ¹			
				C	H	N	O	Pb	Hg			
MAIN OR BOOSTER EXPLOSIVES												
TNT	C ₇ H ₅ N ₃ O ₆	227	1.6	37	2	19	42	—	—	—	—	—
PETN	C ₅ H ₈ N ₄ O ₁₂	316	1.7	19	3	17	61	—	—	—	—	—
RDX	C ₃ H ₆ N ₆ O ₆	222	1.8	16	3	38	43	—	—	—	—	—
TETRYL	C ₇ H ₅ N ₅ O ₈	287	1.7	29	2	24	45	—	—	—	—	—
DETONATOR EXPLOSIVES												
LEAD AZIDE	PbN ₆	291	4.8	—	—	29	—	—	71	—	—	—
MERCURY FULMINATE	HgC ₂ N ₂ O ₂	285	4.4	8	—	10	11	—	—	—	71	—

¹ REFERENCE COLEMAN ET AL. 1974

UNCLASSIFIED

UNCLASSIFIED

Table 4

PHYSICAL PROPERTIES OF SOILS

SOILS	DENSITY	COMPOSITION % WT ¹									
		Si	Al	Fe	Ca	Mg	C	H	N	O	
BLOWN SAND	2.5	32	2	.2	0	0	0	0	0	0	66
DANUBE SILT	2.5	11	2	2	3	1	7	27	.1	.1	46
SALT LAKE ADOBE	2.5	6	1	0	11	1	15	8	.1	.1	57
MARSH LAND	2.5	2	0	0	1	0	13	51	.05	.05	32
ALBUQUERQUE DIRT	1.6	17	35	1	3	.3	0	0	0	0	44

UNCLASSIFIED

UNCLASSIFIED

¹ REFERENCE POWELL AND MATTHEWS 1971

Table 5

PHYSICAL AND CHEMICAL PROPERTIES OF EXPLOSIVES VAPOURS¹

EXPLOSIVE	CHARACTERISTIC VAPOUR	SOURCE OF VAPOUR	MOLECULAR WEIGHT	MAXIMUM CONCENTRATION IN AIR (ng/m ³) (~ 20°C)
DYNAMITE	ETHYLENE GLYCOL DINITRATE	EXPLOSIVE	152	3×10^8
GELIGNITE	NITROGLYCERINE	EXPLOSIVE	227	2×10^7
TNT	DNT TNT	IMPURITY EXPLOSIVE	182 227	1.6×10^6 4×10^4
SMOKELESS POWDER	DIPHENYL AMINE	IMPURITY	168	8×10^4
C4	RDX	EXPLOSIVE	222	10^4
PETN	PETN	EXPLOSIVE	316	10^4

¹ DEL MARKHAM 1977

UNCLASSIFIED

UNCLASSIFIED

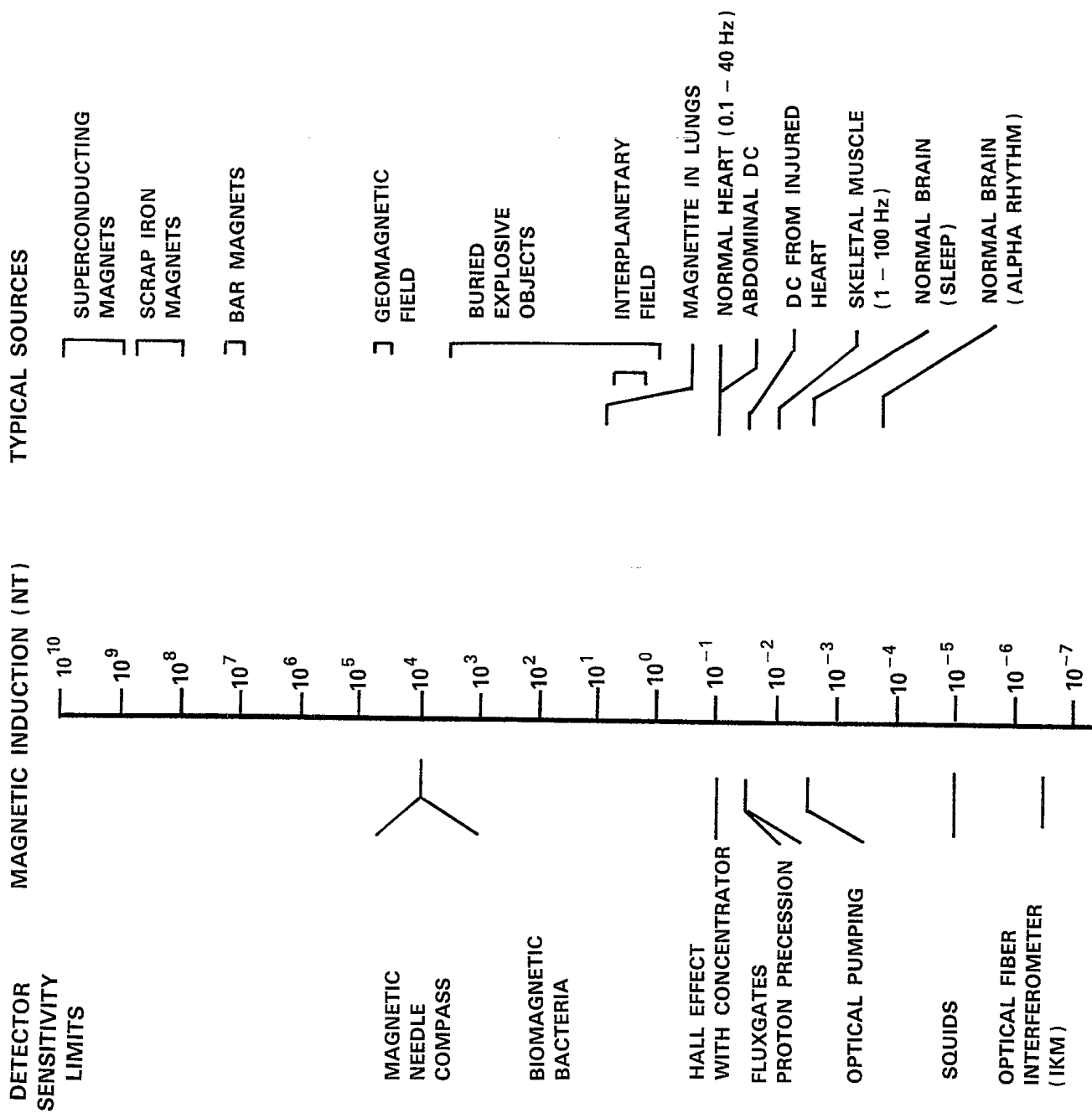

Figure 1

THE INTENSITY RANGE OF TERRESTRIAL MAGNETIC FIELDS AND TYPICAL DETECTORS.

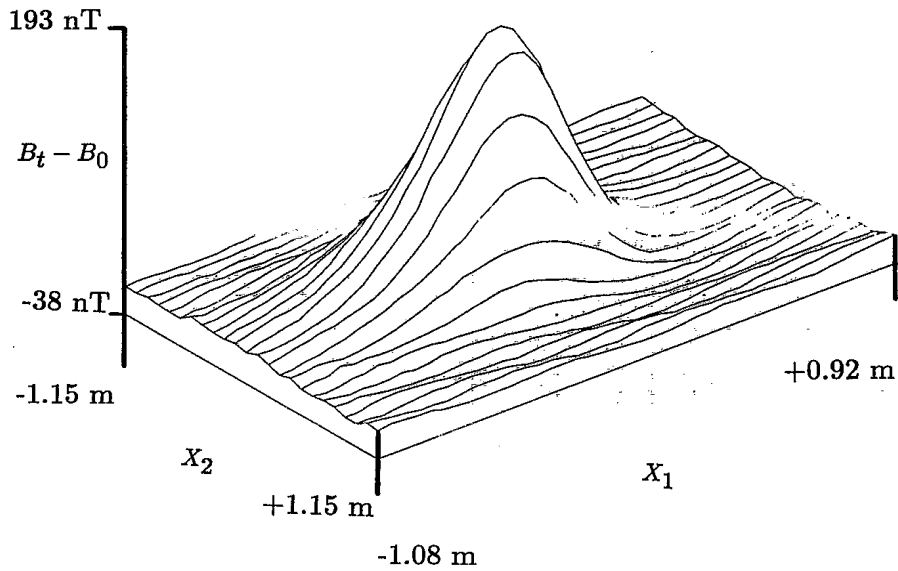
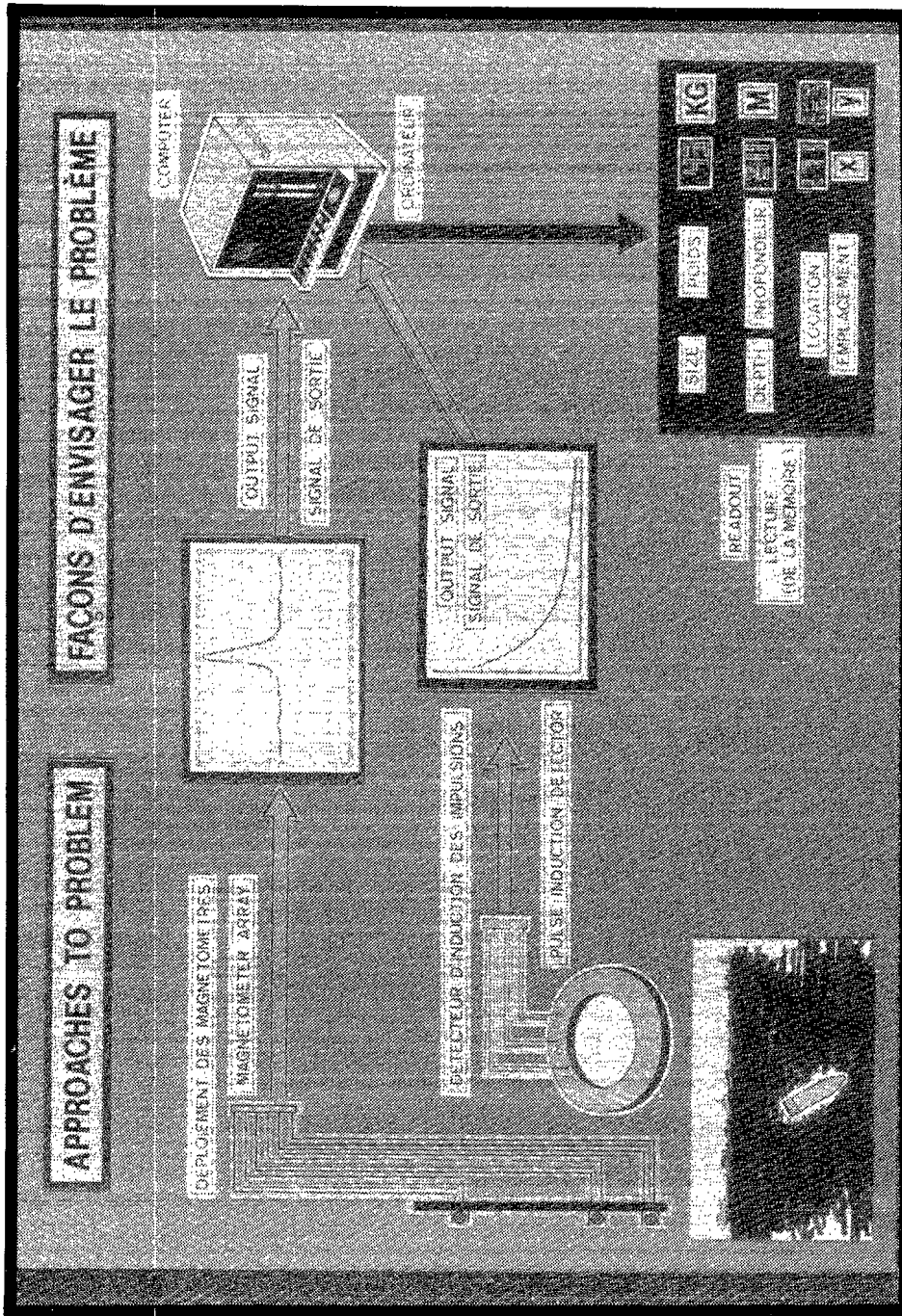

Figure 2

MAGNETIC FIELD INTENSITY IN A HORIZONTAL PLANE 0.55 m ABOVE A PRO-LATE MILD STEEL SPHEROID. THE SPHEROID CENTER IS IMMEDIATELY BELOW (0,0) AND THE SPHEROID SEMI-MAJOR AND MINOR AXES ARE 0.12 m AND 0.06 m.



90-226

Figure 3

GENERAL METHOD OF LOCATION OF A METALLIC MUNITION BY "SMART" MAGNETOMETERS AND ELECTROMAGNETIC INDUCTION. SPATIALLY VARYING SIGNALS FROM A MAGNETOMETER OR SPATIALLY AND TEMPORALLY VARYING SIGNALS FROM AN ELECTROMAGNETIC INDUCTION DETECTOR ARE ANALYSED BY A COMPUTER TO DETERMINE POSITION (X, Y, DEPTH) AND IDENTITY (MASS).

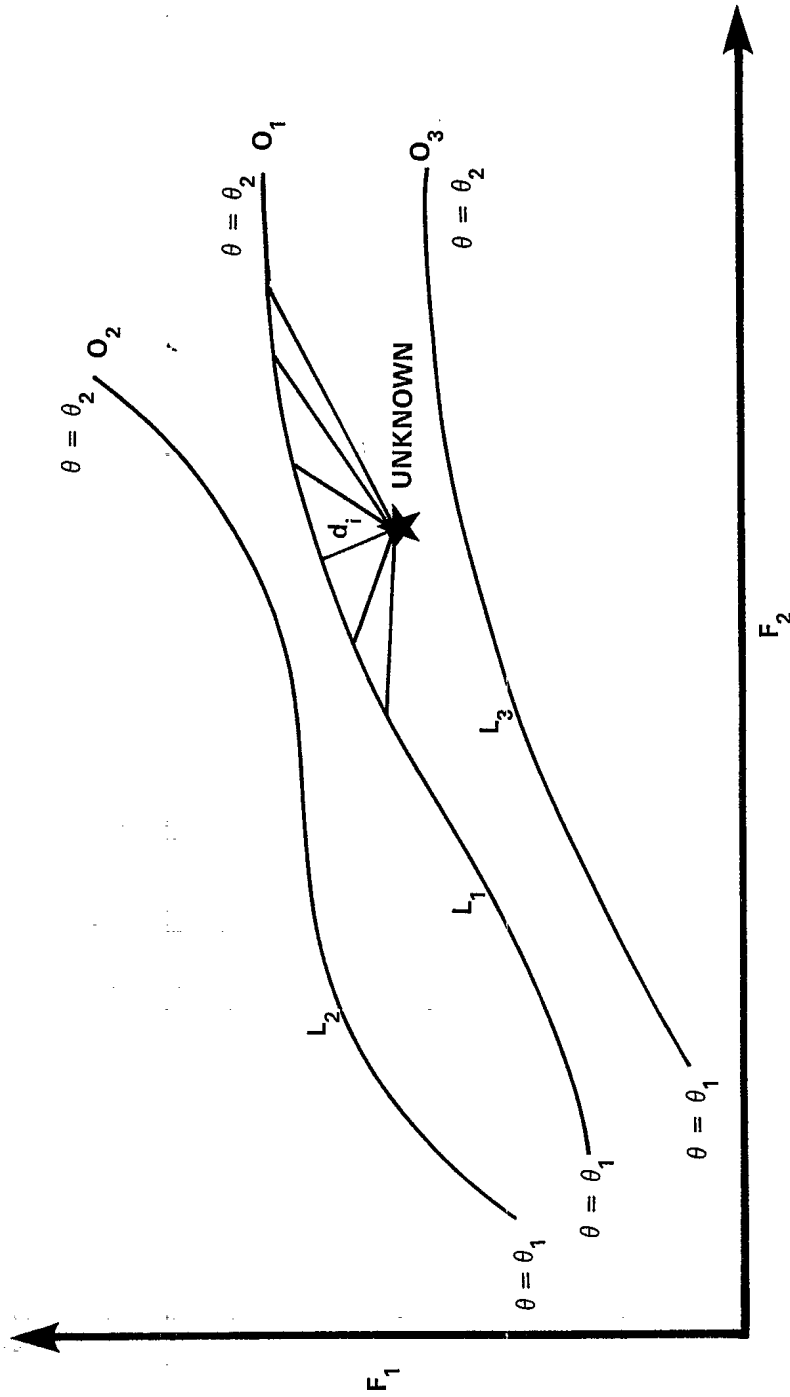

$$d_i = \min d(x, L_i)$$
$$x \in O_i \text{ if } d_i < d_j \text{ FOR ALL } j \neq i$$

Figure 4
CONCEPT OF PATTERN CLASSIFICATION FOR CONTINUOUS DESIGN SETS.

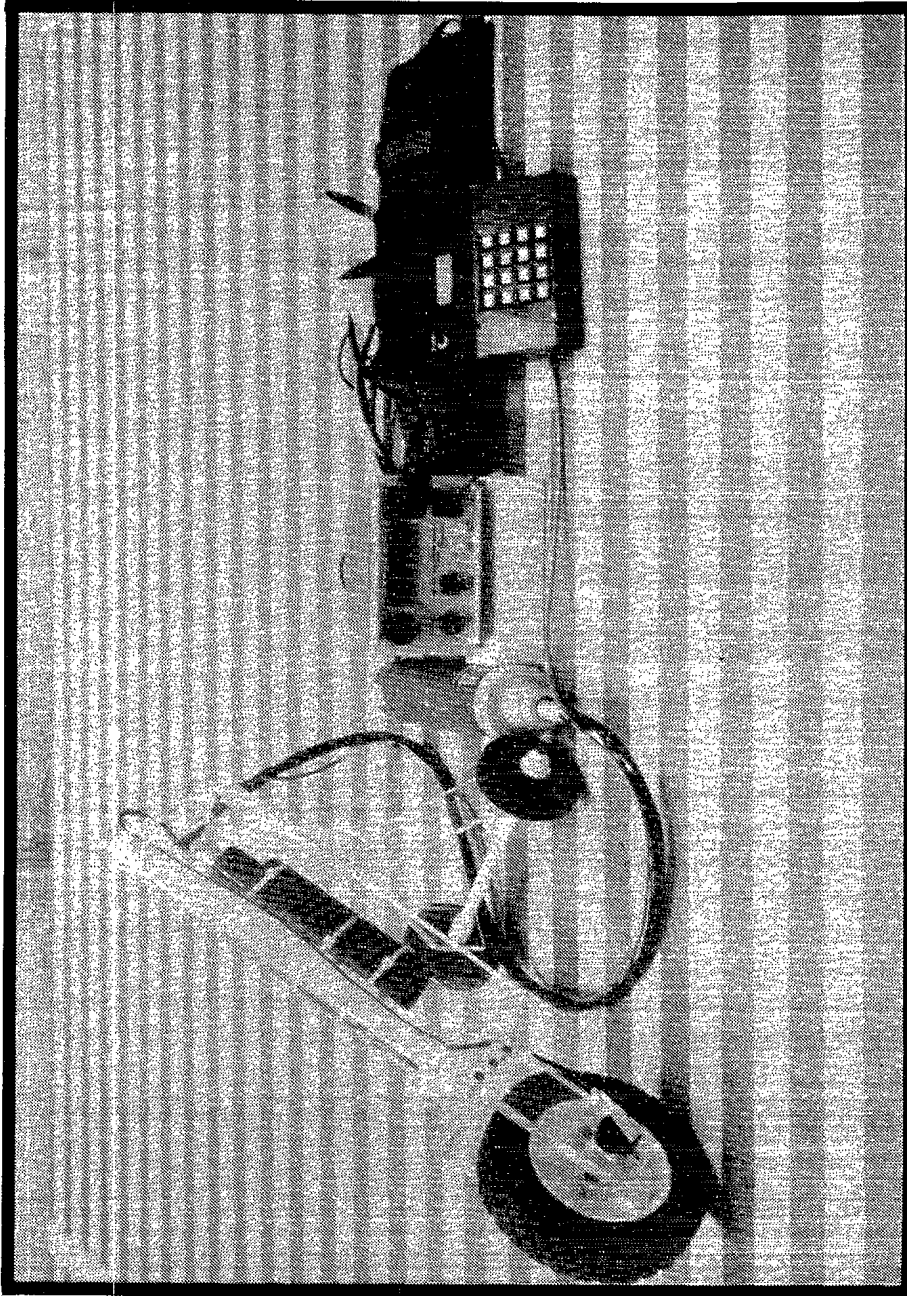

Figure 5
"SMART" TOTAL FIELD MAGNETOMETER DEVELOPED BY DRES.

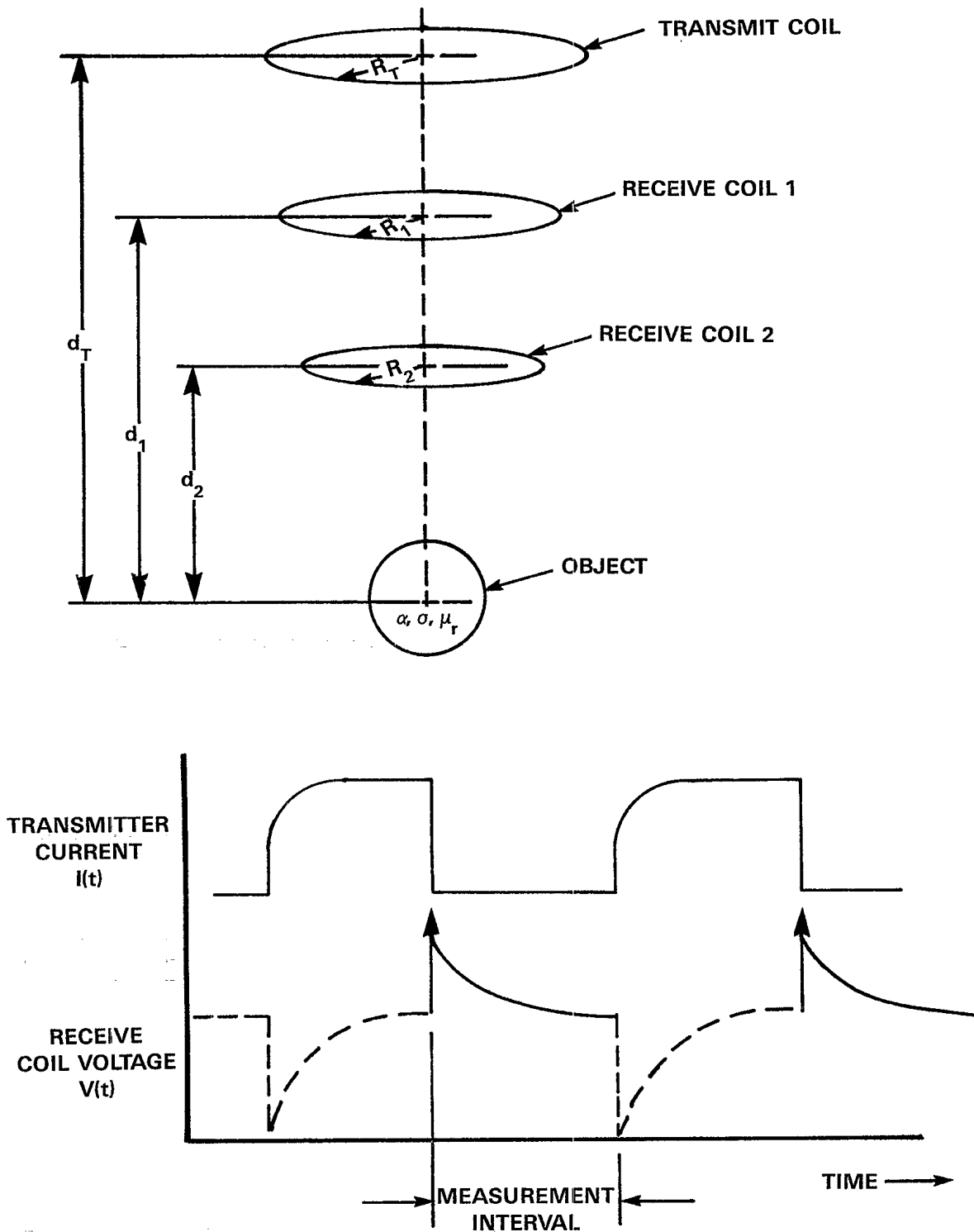

Figure 6

METHOD OF TRANSIENT ELECTROMAGNETIC INDUCTION. GEOMETRY OF COILS AND OBJECT IS SHOWN IN UPPER FIGURE. IDEALIZED CURRENT AND RECEIVER VOLTAGE ARE SHOWN IN LOWER FIGURE.

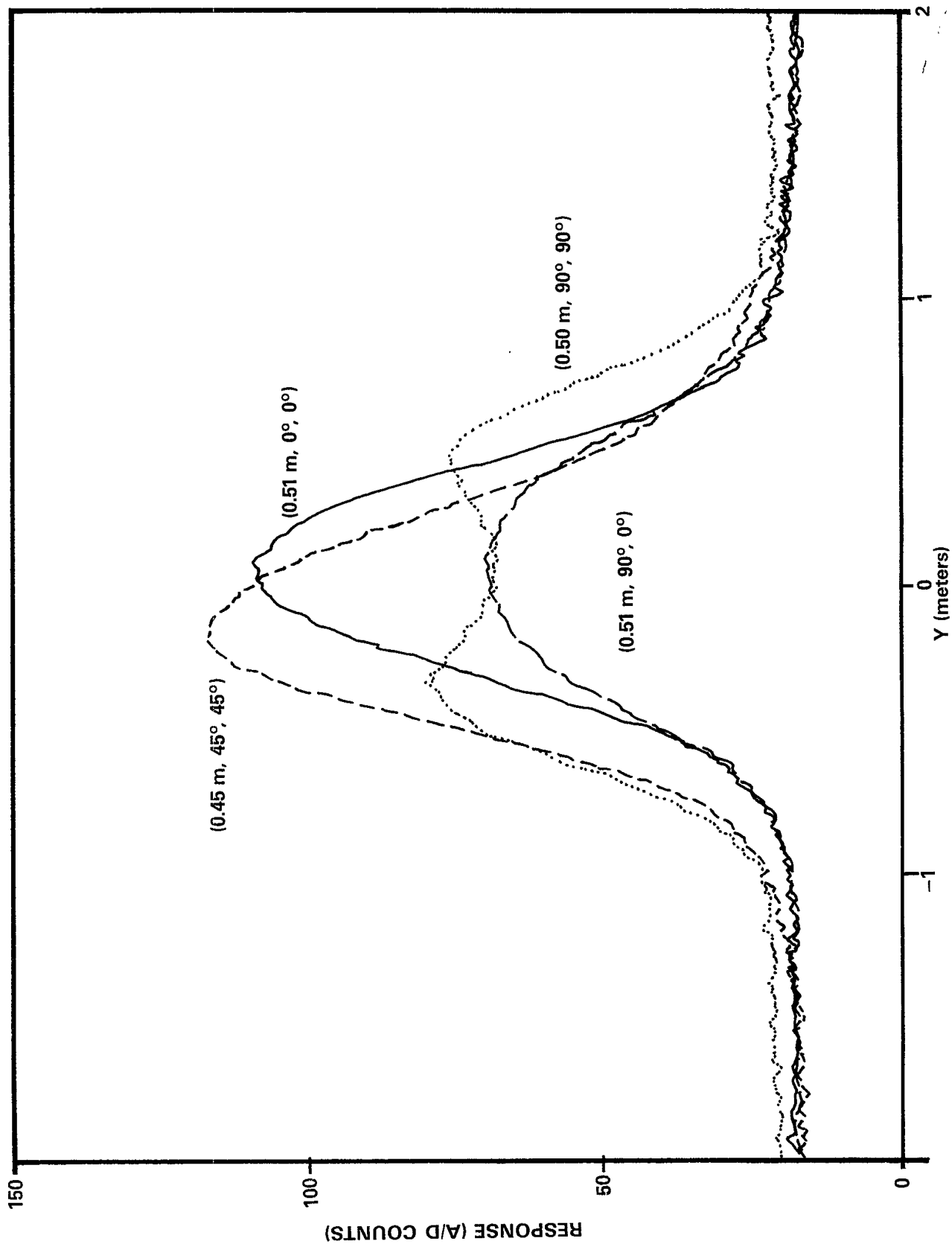

Figure 7

MEASURED SPATIAL VARIATION OF PULSE INDUCTION RESPONSE OF A SPHEROID FOR A NUMBER OF ORIENTATIONS. (d, θ , ϕ) GIVE THE DEPTH, AND POLAR AND AZIMUTHAL ANGLES RESPECTIVELY OF THE SYMMETRY AXIS OF THE SPHEROID.

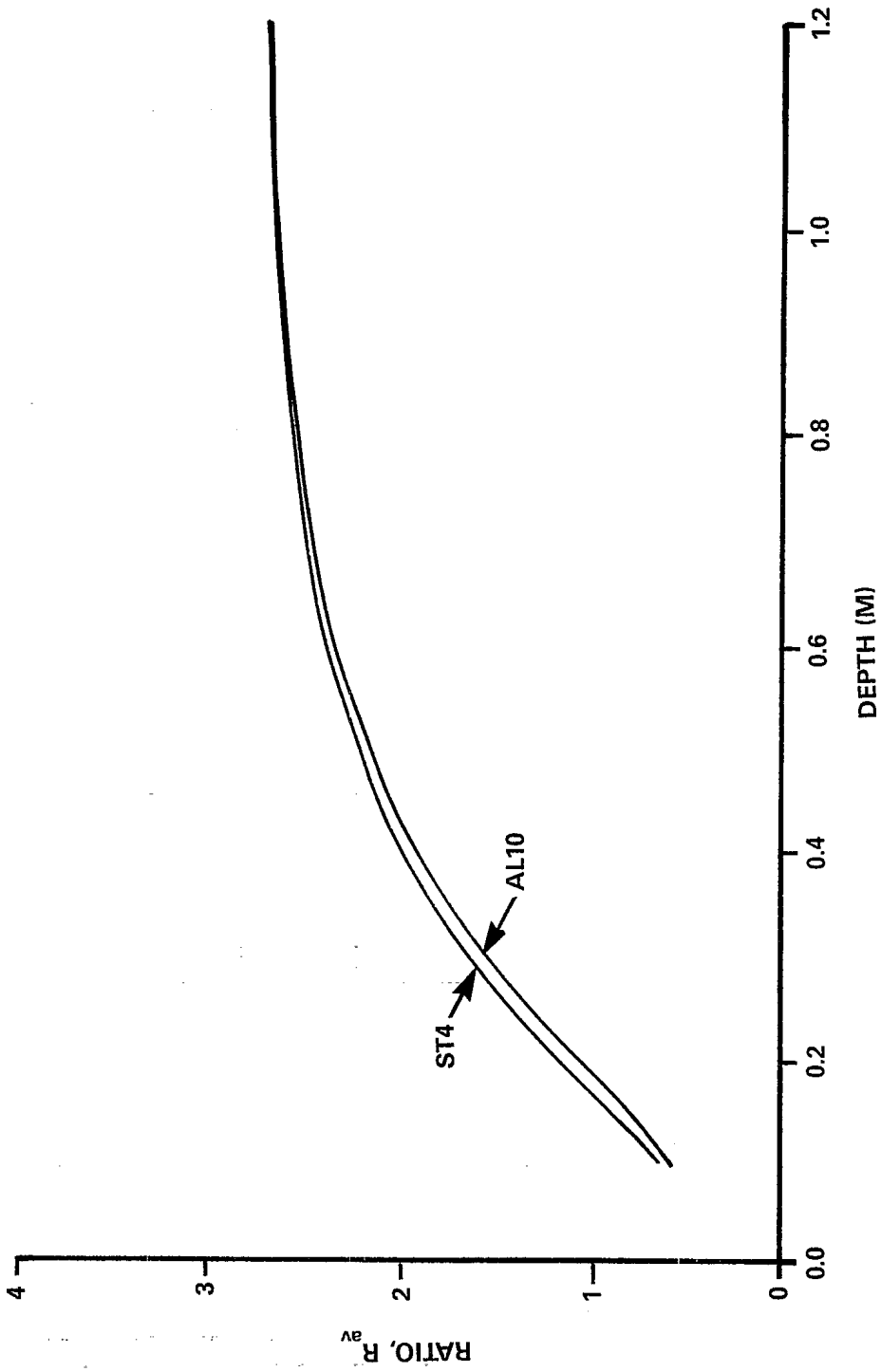

Figure 8

RATIO OF VOLTAGE INDUCED IN TWO PULSE INDUCTION RECEIVE COILS AS A FUNCTION OF DEPTH OF OBJECT BURIAL FOR THE TWO LIMITING CASES (0.04 m RADIUS STEEL SPHERE AND 0.10 m RADIUS ALUMINUM SPHERE) FOR ORDNANCE DETECTION.

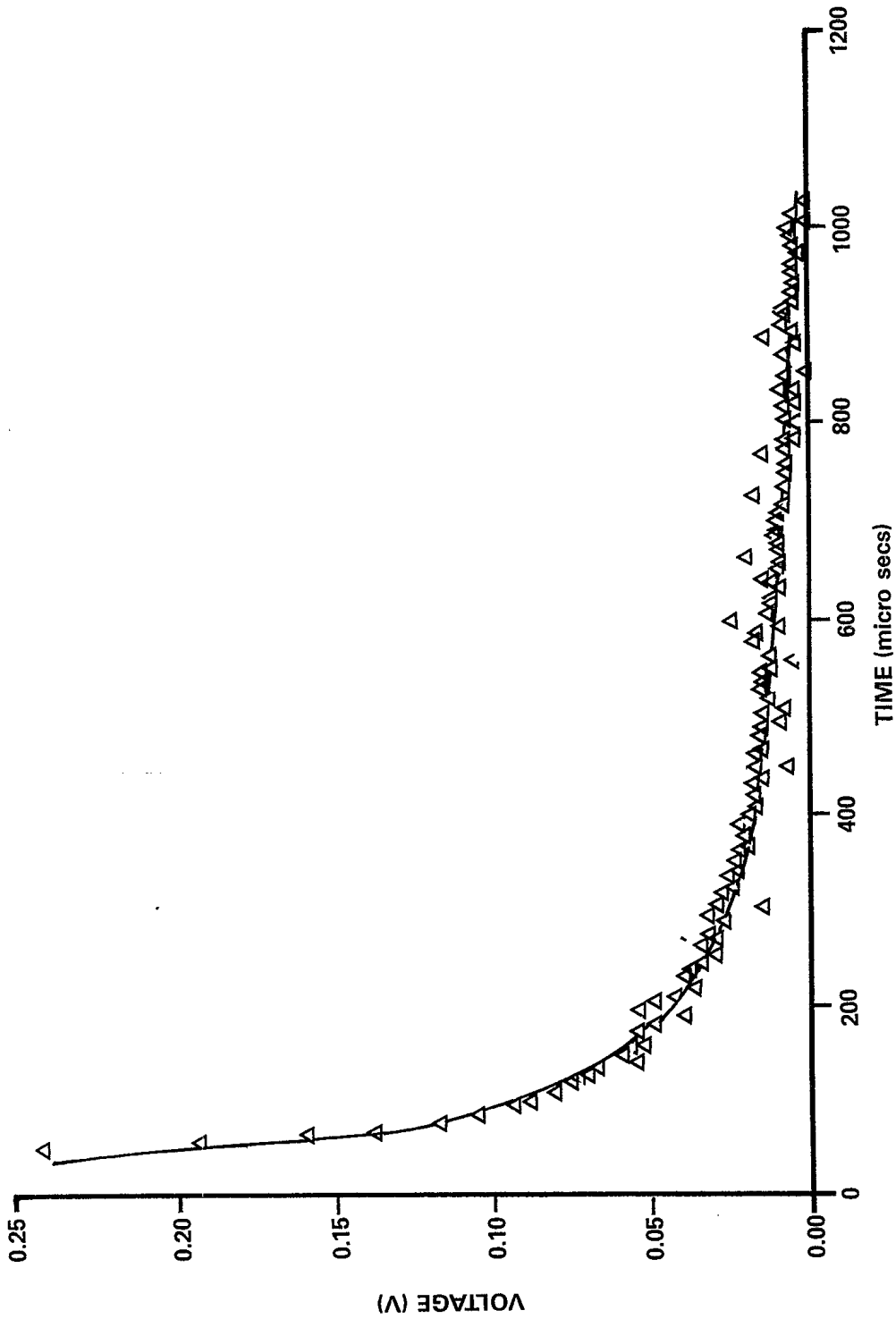
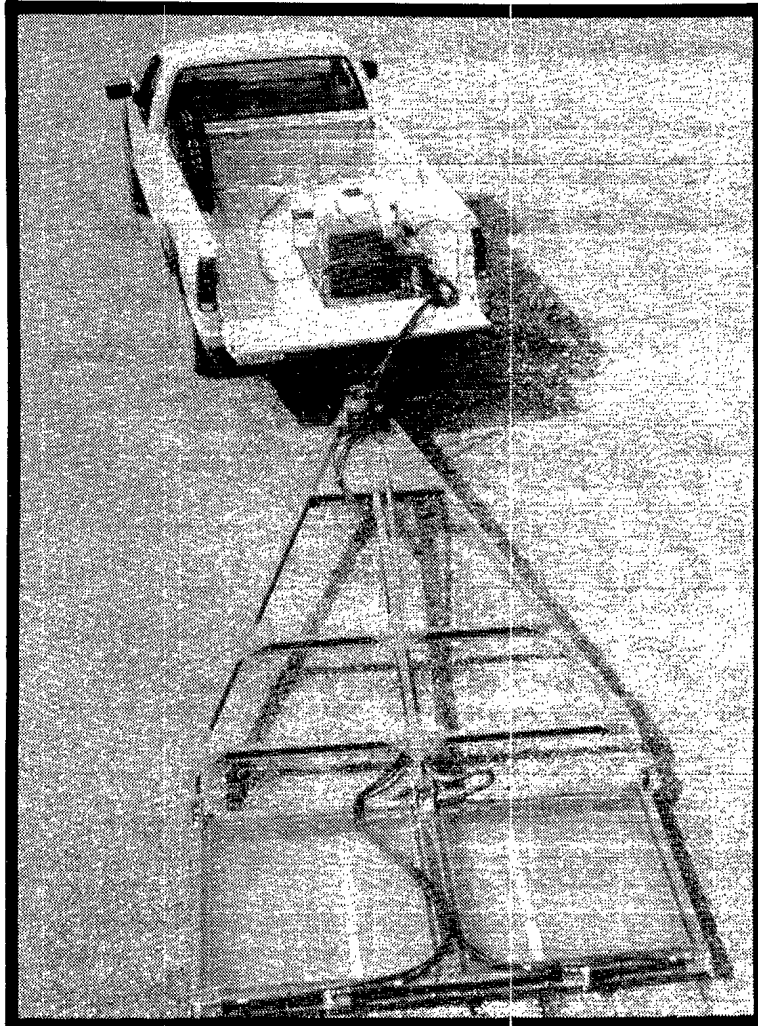

Figure 9

VOLTAGE INDUCED IN PULSE INDUCTION RECEIVE COIL BY A 0.08 m RADIUS STEEL SPHERE. TRIANGLES ARE MEASURED DATA. CURVE IS A SPHERE MODEL WHICH ULTIMATELY CONSISTS OF A SUM OF DAMPED EXPONENTIALS.



89-299

Figure 10
VEHICLE MOUNTED ORDNANCE LOCATOR (VMOD).

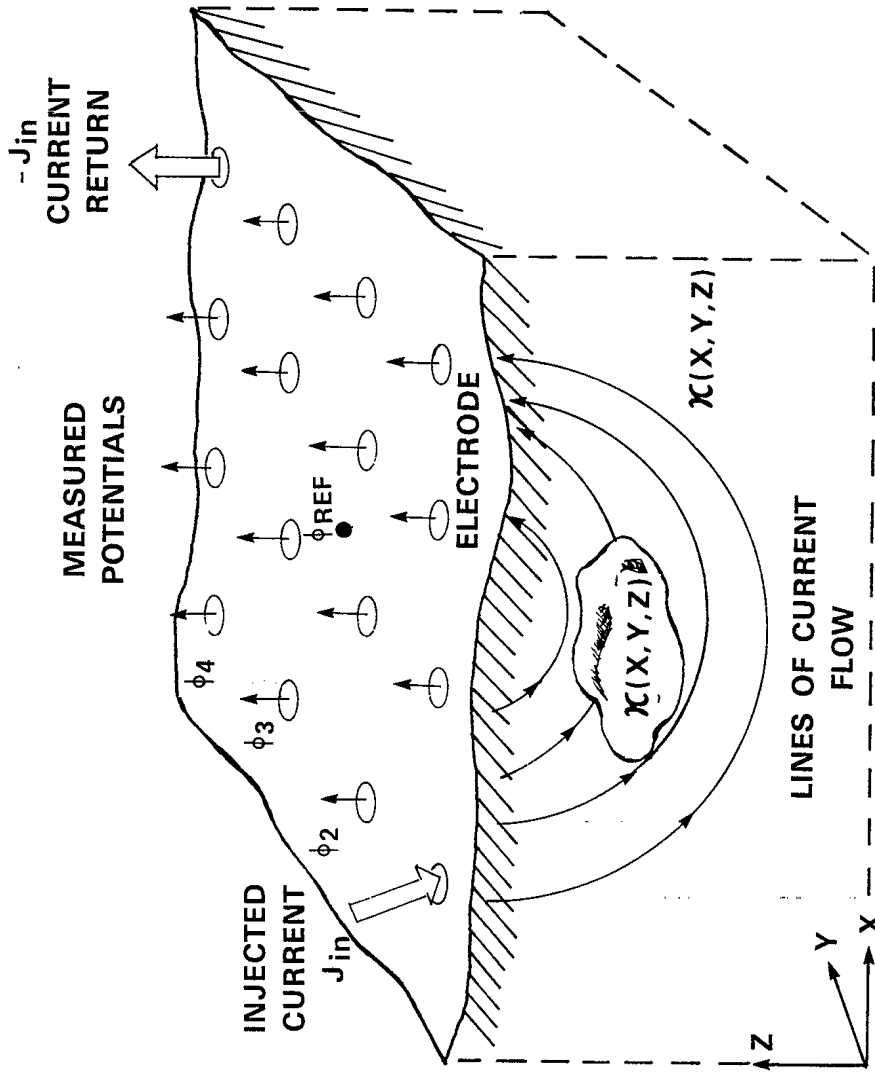

Figure 11

THE GEOMETRY OF IMPEDANCE TOMOGRAPHY.

UNCLASSIFIED

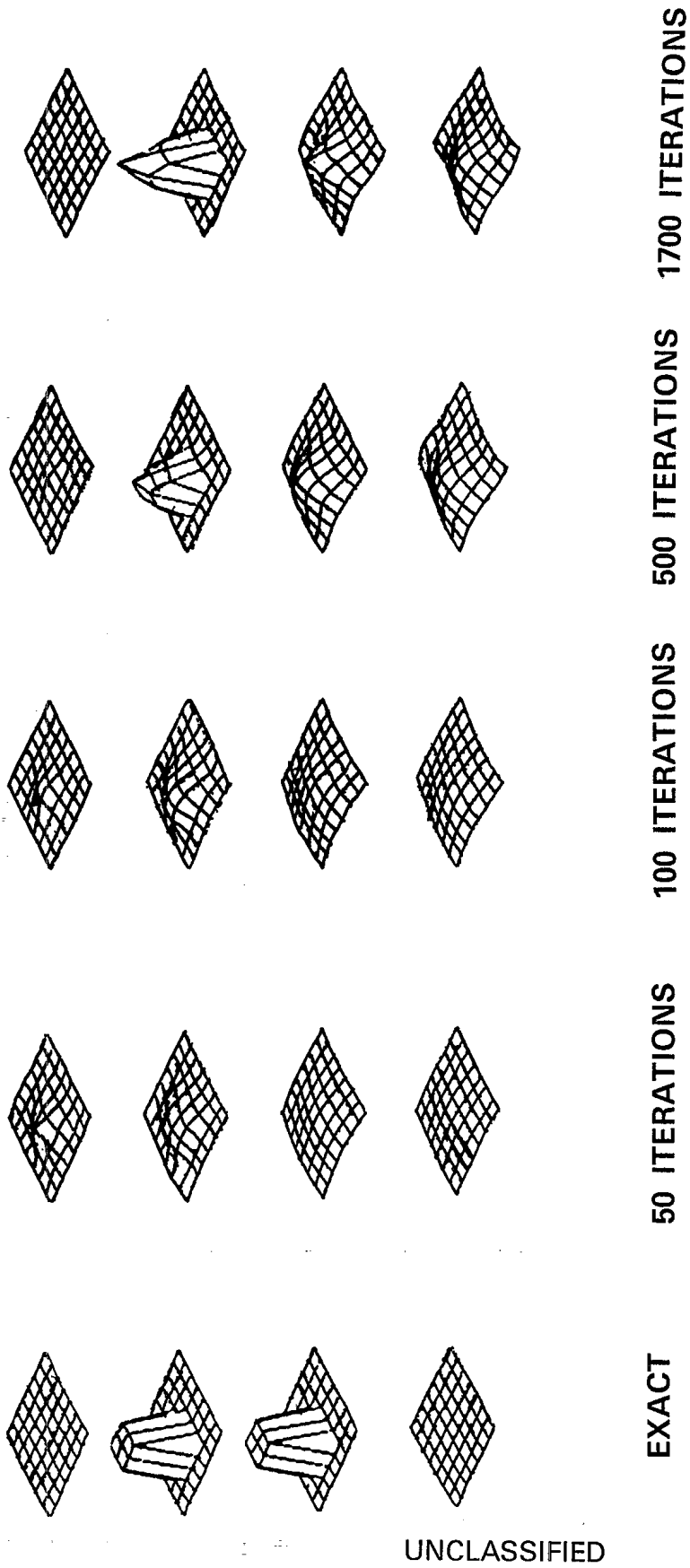

Figure 12

RESULTS OF RECONSTRUCTION OF A COMPUTER GENERATED CONDUCTIVITY DISTRIBUTION BASED ON SIMULATED MEASUREMENT OF VOLTAGES ON THE TOP SURFACE OF THE VOLUME.

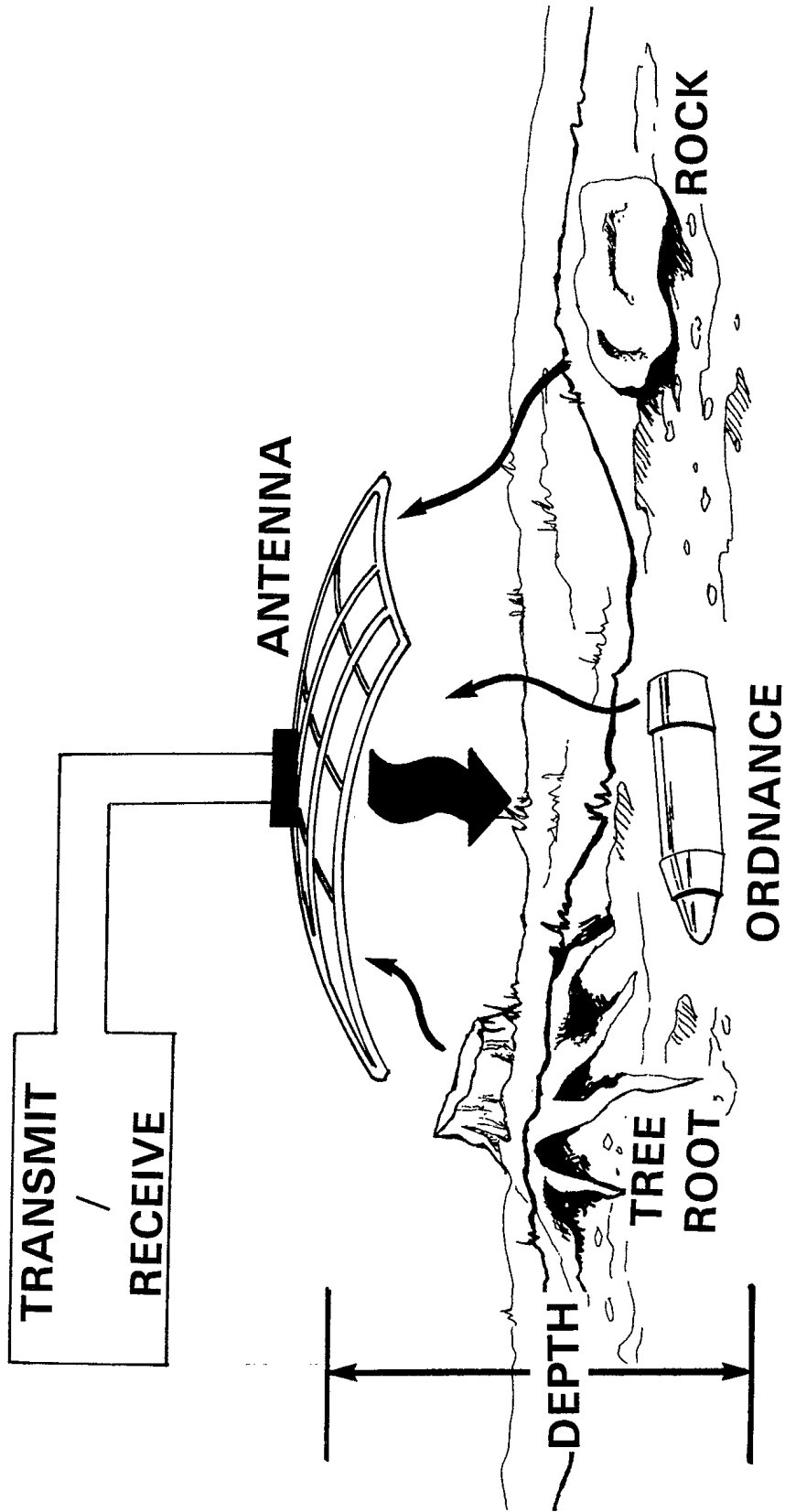

Figure 13
 THE DETECTION OF BURIED MUNITIONS USING ACTIVE MICROWAVES, SHOWING FACTORS WHICH AFFECT A RECEIVED SIGNAL.

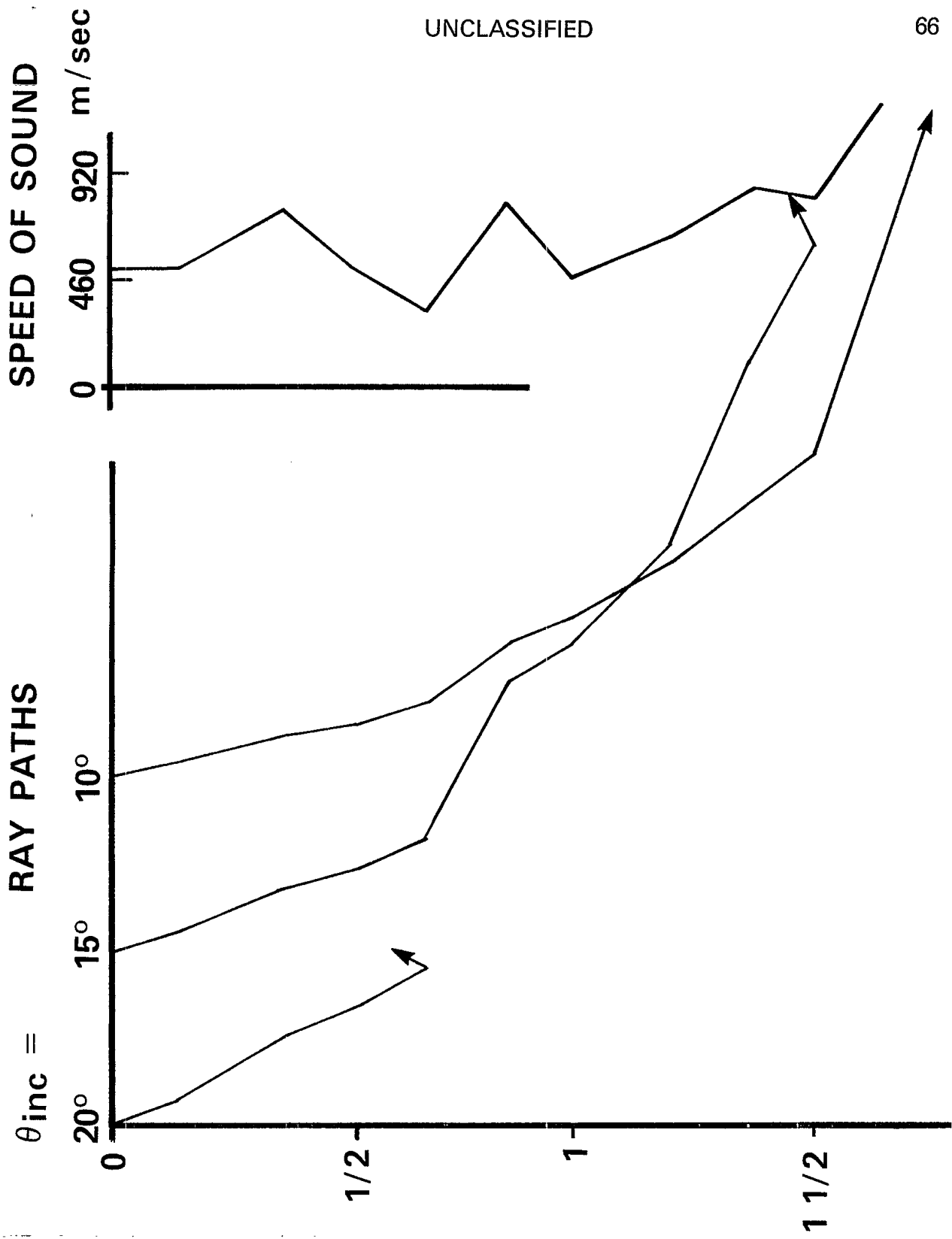

Figure 14

SPEED OF SOUND IN A TYPICAL SOIL SAMPLE AS FUNCTION OF DEPTH (UPPER GRAPH). THE RAY PATH OF AN ACOUSTIC WAVE FOR DIFFERENT ANGLES OF INCIDENCE (LOWER GRAPH).

TEMPERATURE PROFILE

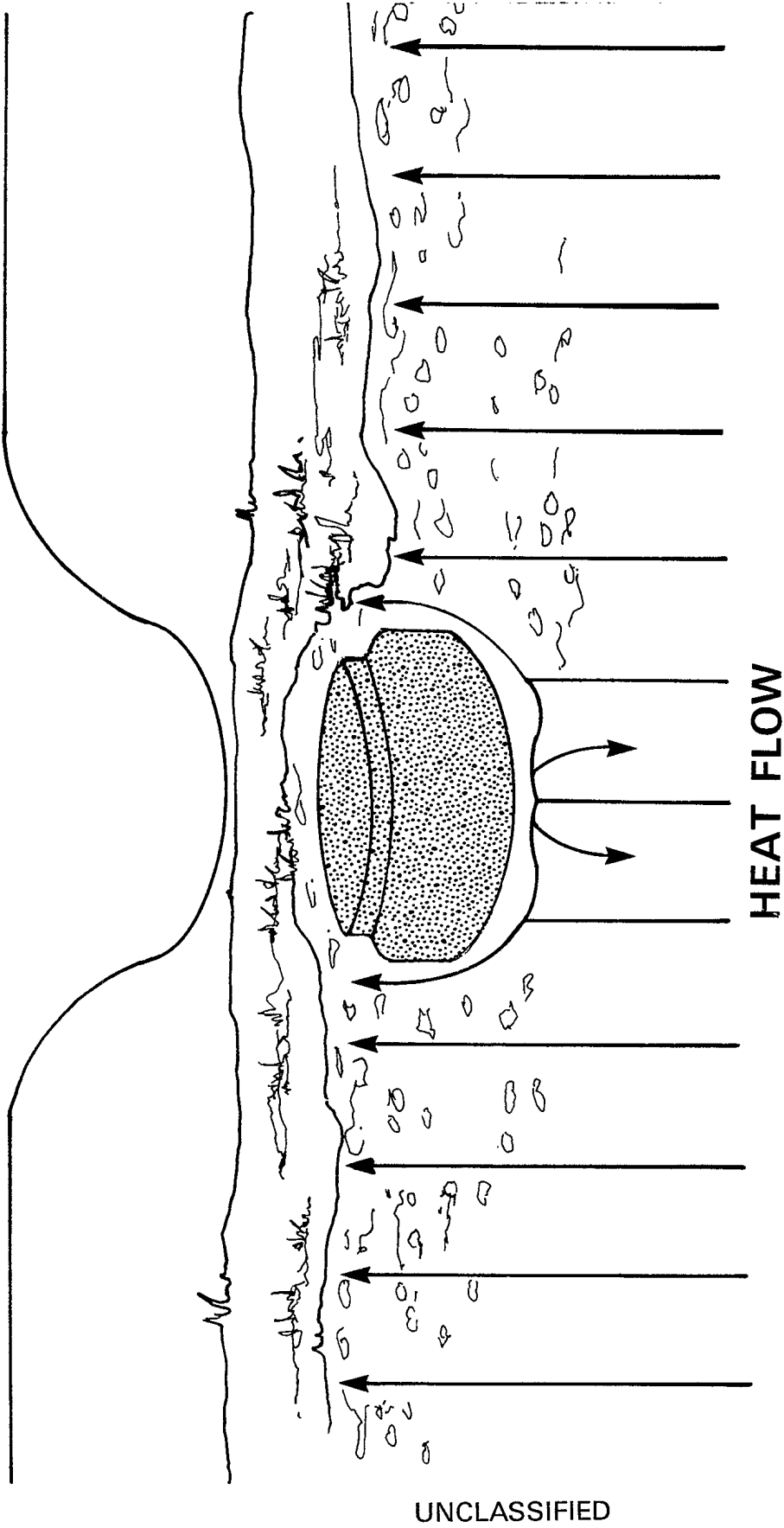

Figure 15

THE DISTURBANCE OF HEAT FLOW DUE TO AN OBJECT BURIED IN A MEDIUM CAUSES A CHANGE IN THE TEMPERATURE PROFILE IMMEDIATELY OVER THE OBJECT.

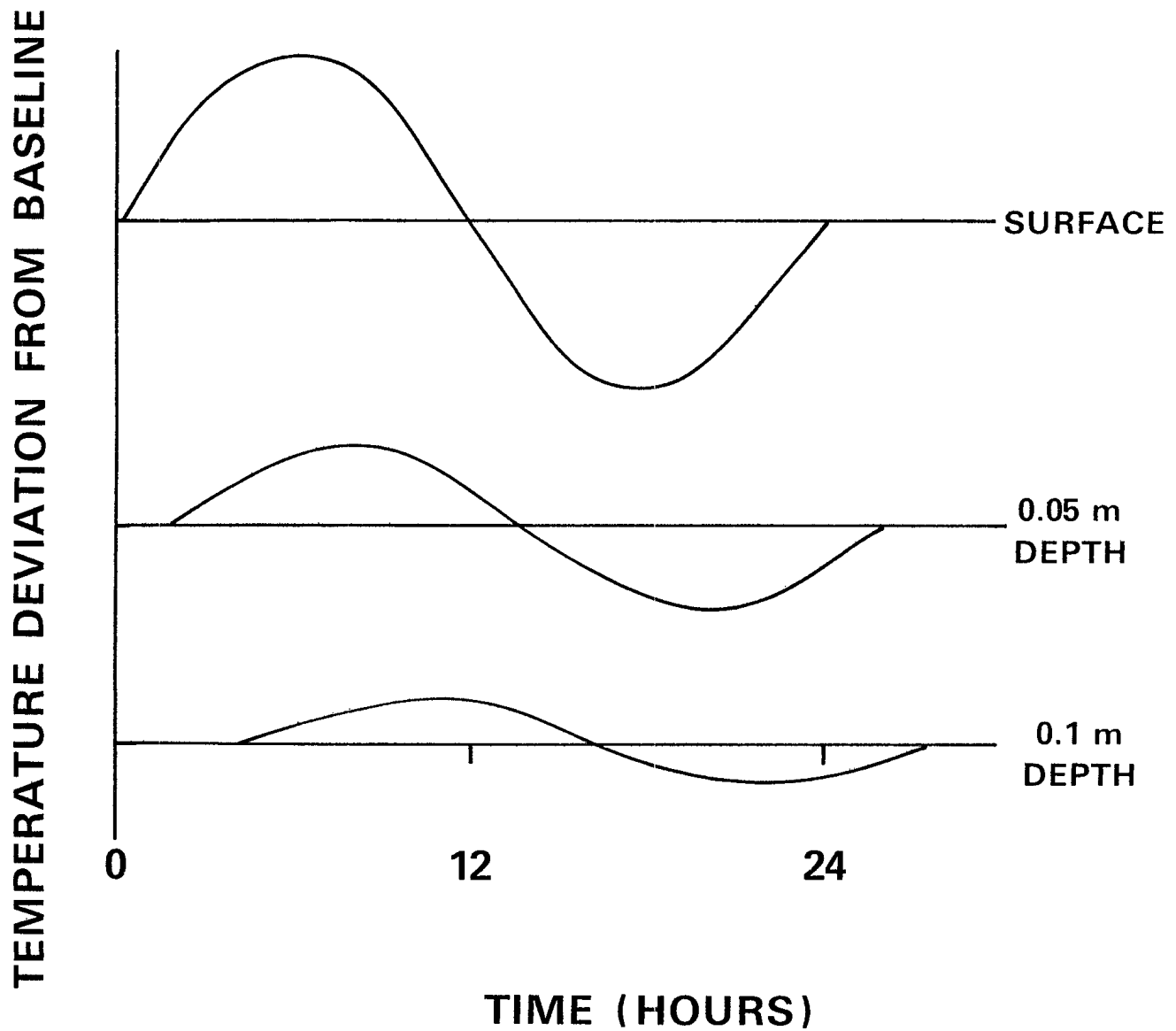

Figure 16

DIURNAL VARIATION OF TEMPERATURE AS A FUNCTION OF DEPTH IN A UNIFORM THERMALLY CONDUCTIVE MEDIUM.

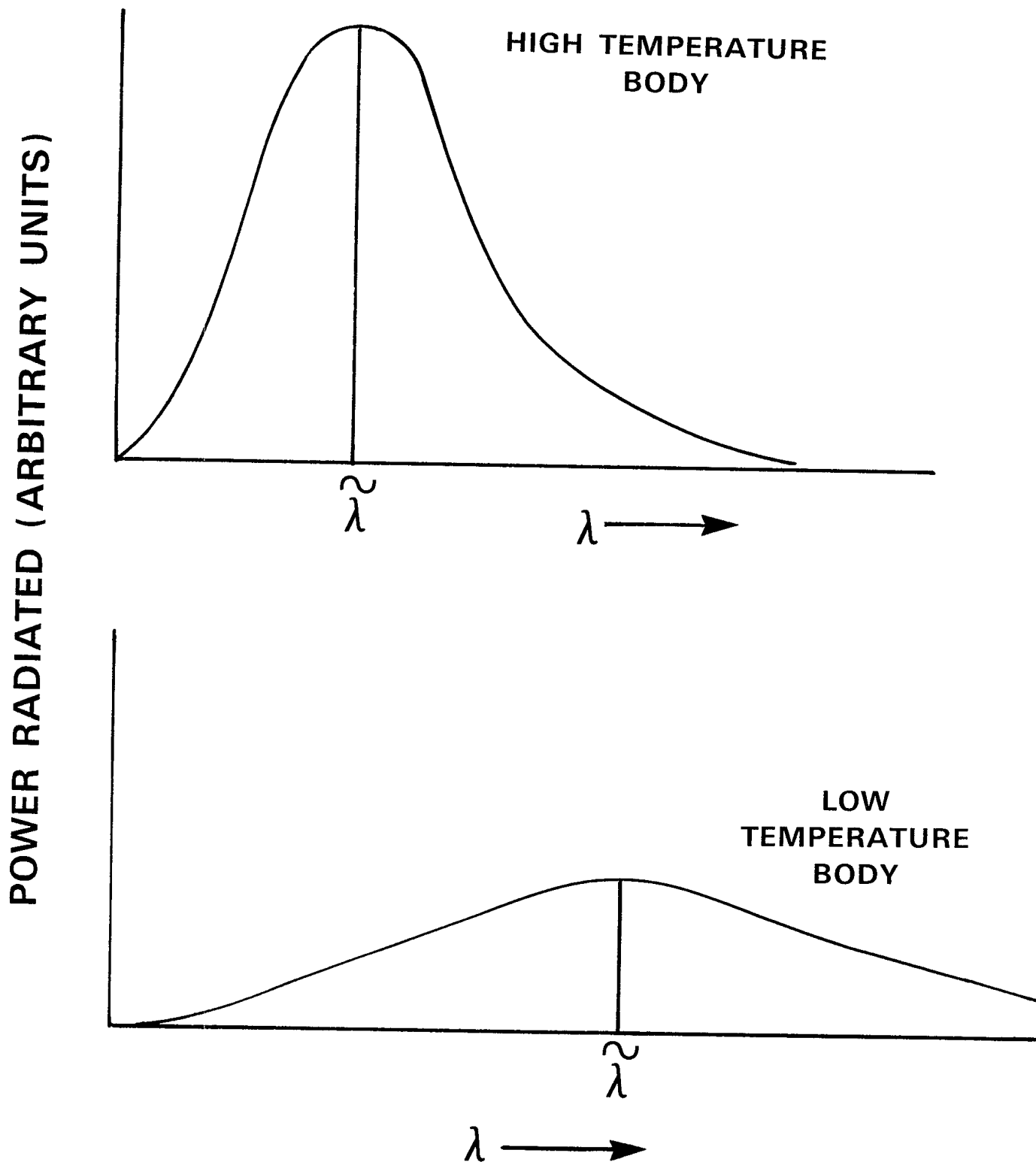

Figure 17

TYPICAL SPECTRA AS A FUNCTION OF WAVELENGTH λ FOR TWO IDENTICAL BLACK OR GRAY BODIES AT DIFFERENT TEMPERATURES.

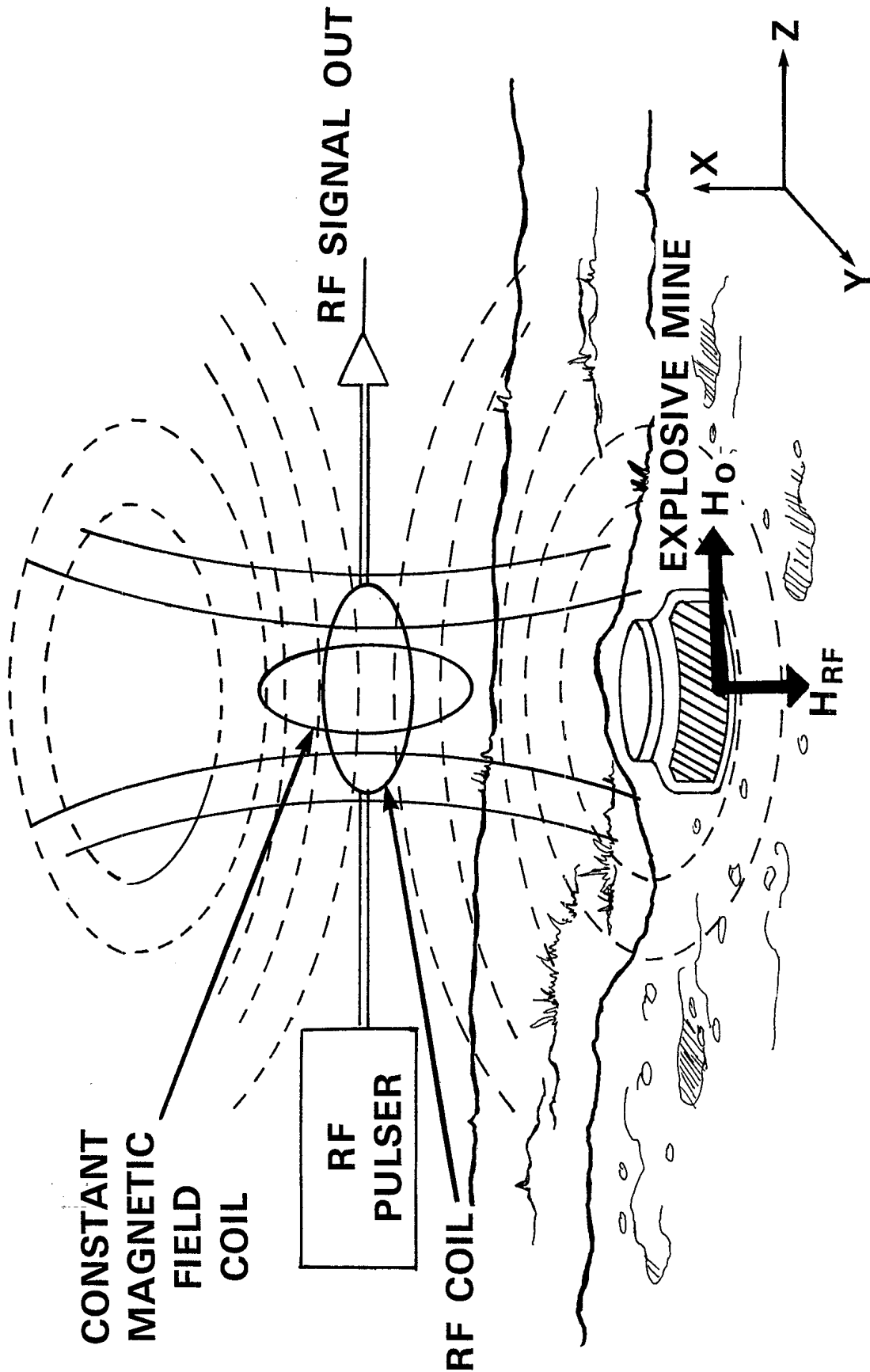

Figure 18
GEOMETRY FOR NMR DETECTION OF EXPLOSIVES IN A NONMETALLIC MINE.

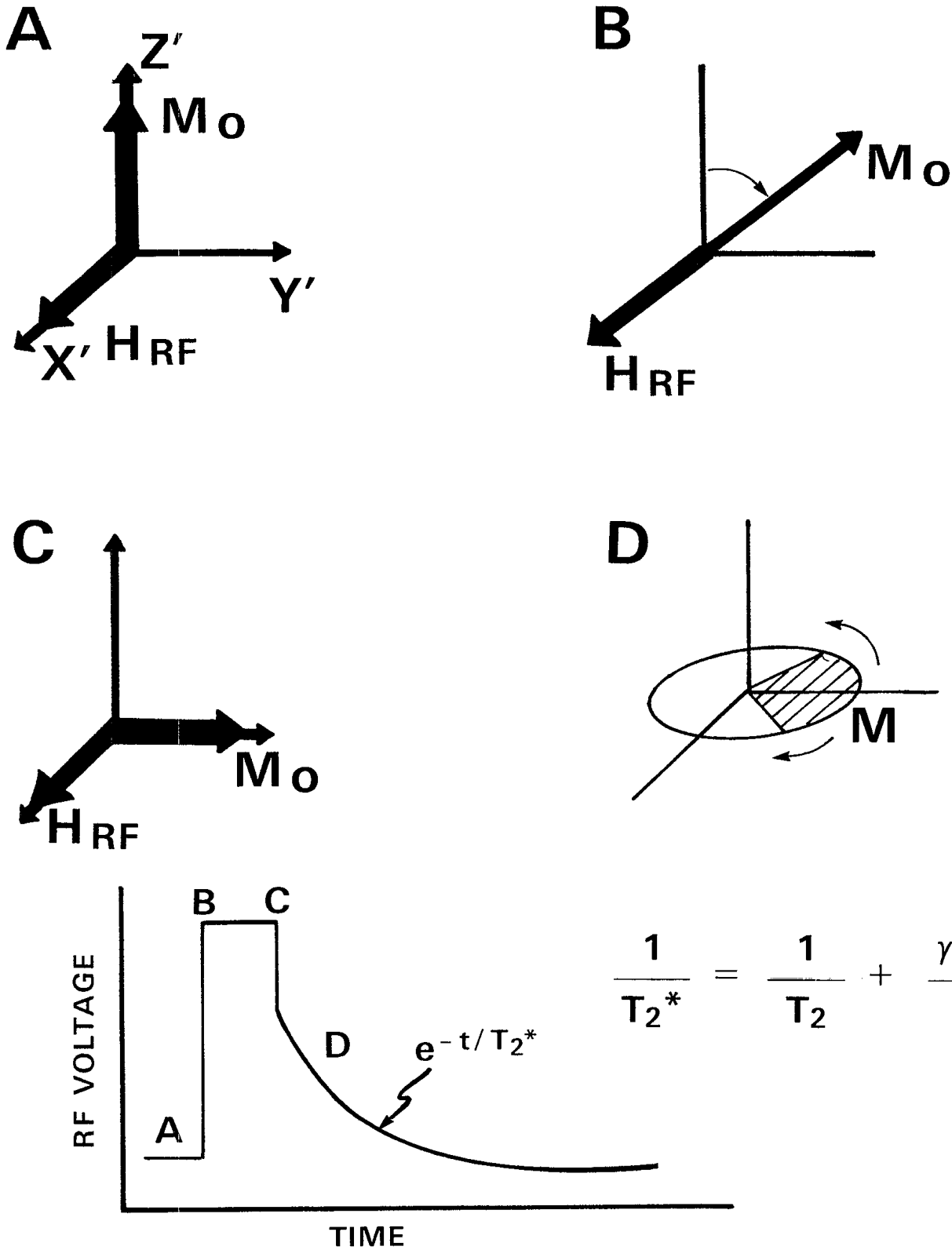

Figure 19

NMR FREE INDUCTION DECAY SHOWING ORIENTATION OF MAGNETIC MOMENT VECTOR AT VARIOUS POINTS DURING THE RADIOFREQUENCY VOLTAGE WAVEFORM.

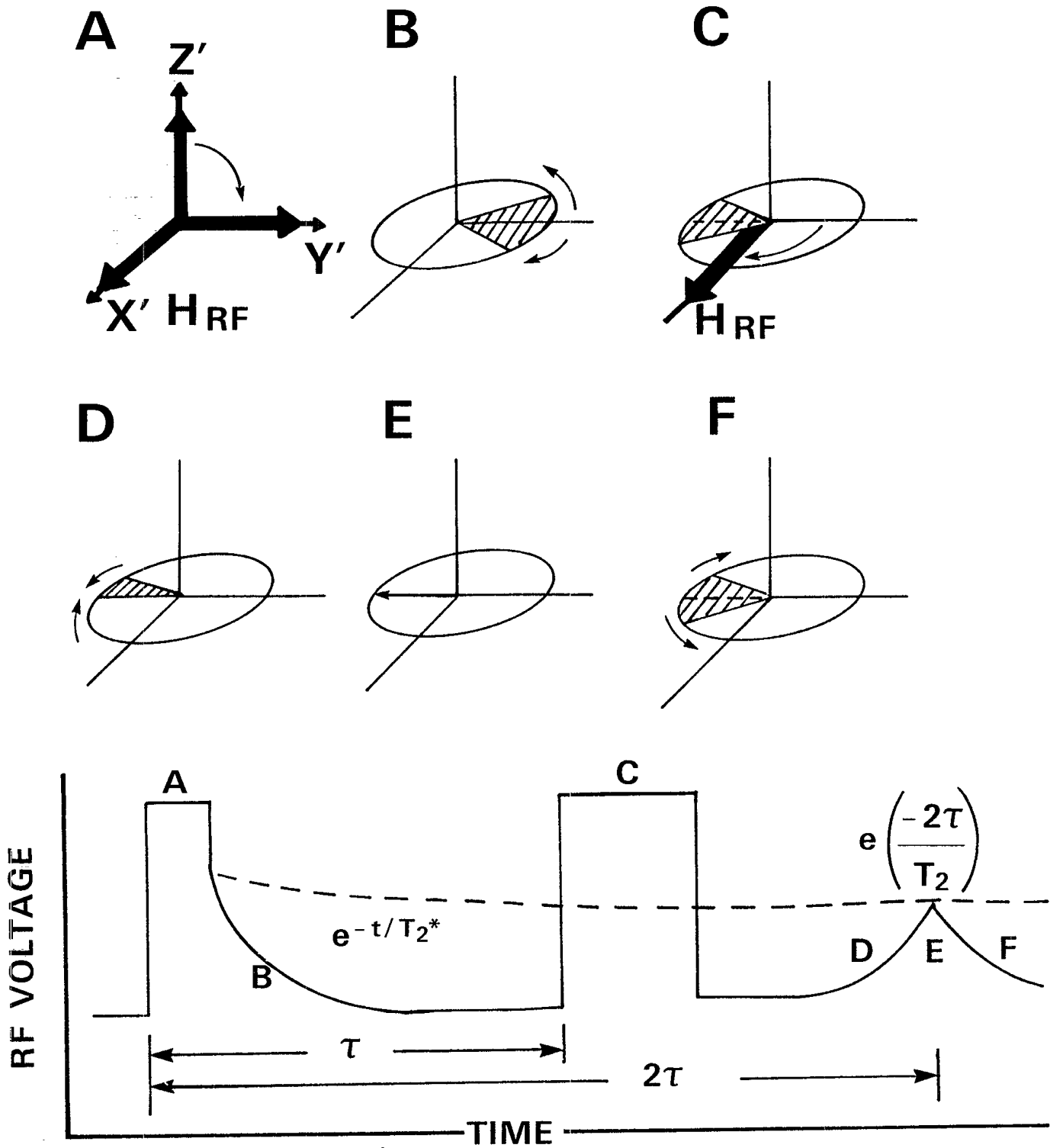

Figure 20

NMR SPIN ECHO SHOWING ORIENTATION OF MAGNETIC MOMENT VECTOR AT VARIOUS POINTS DURING THE RADIOFREQUENCY VOLTAGE WAVEFORM.

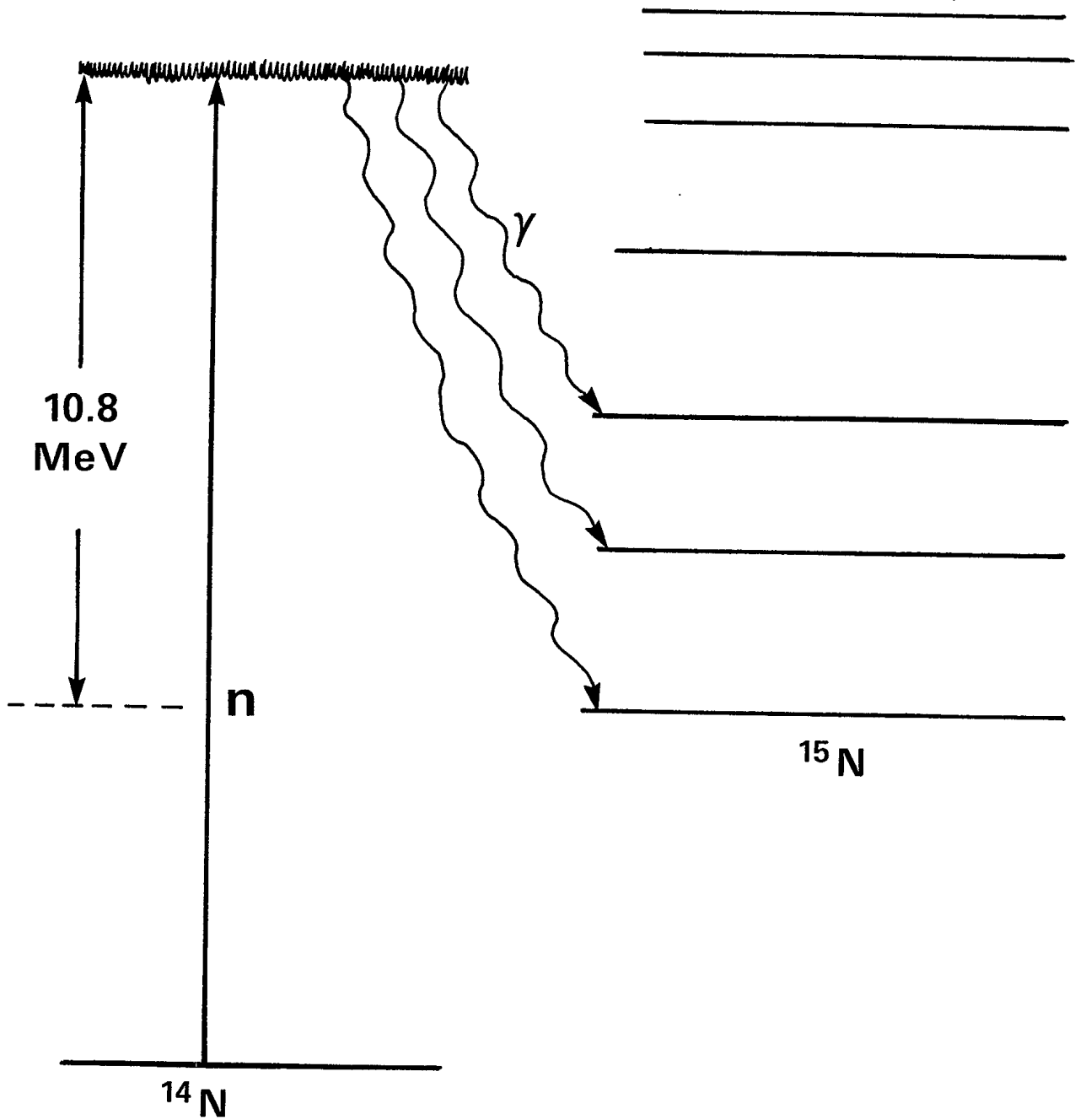

Figure 21
SCHEMATIC DIAGRAM OF THE $^{14}\text{N}(n,\gamma)^{15}\text{N}$ REACTION.

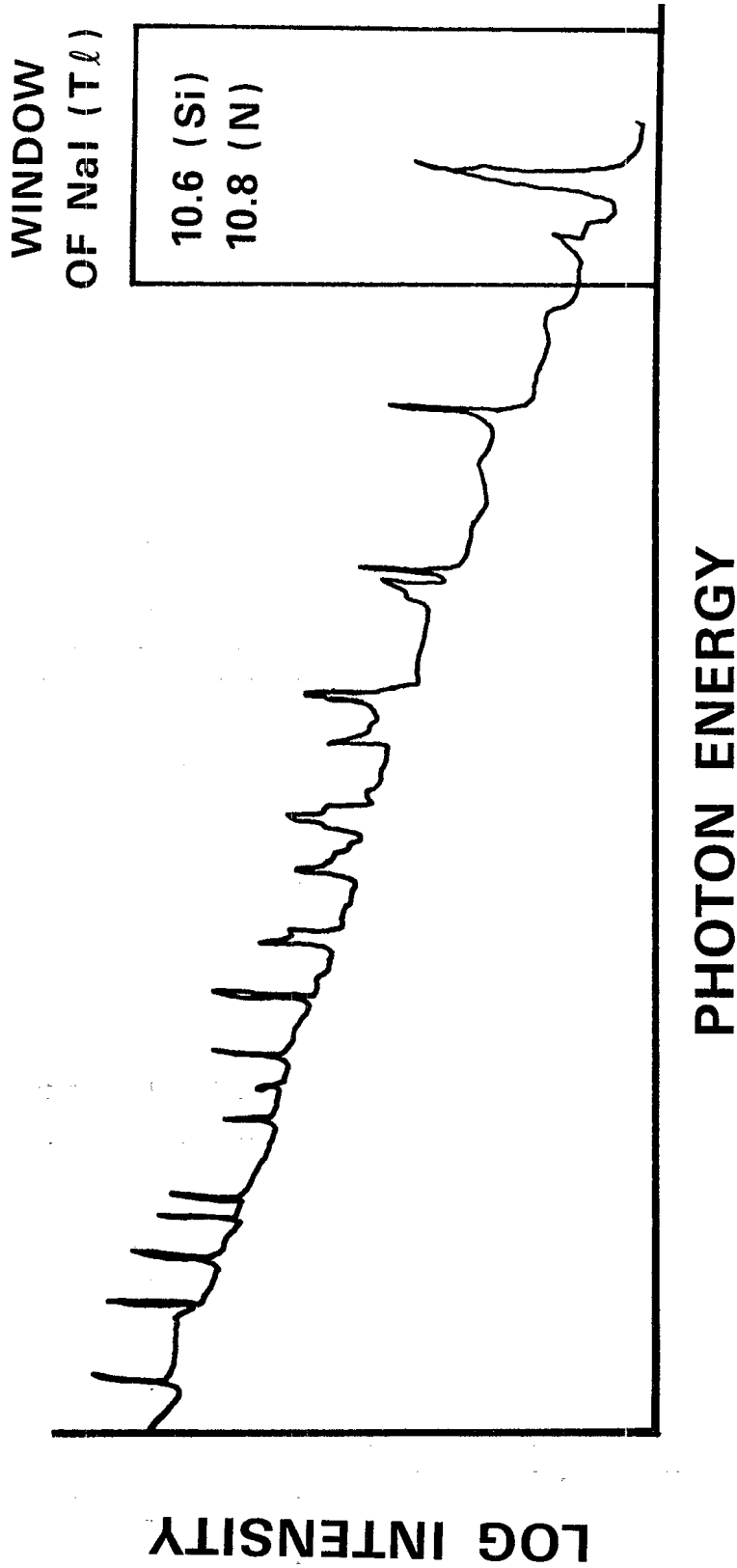

Figure 22
THE SCHEMATIC ENERGY SPECTRUM OF THE $^{14}\text{N}(n,\gamma)^{15}\text{N}$ REACTION WITH A NaI(Tl) SCINTILLATION DETECTOR WINDOW CENTERED AT 10.8 MeV.

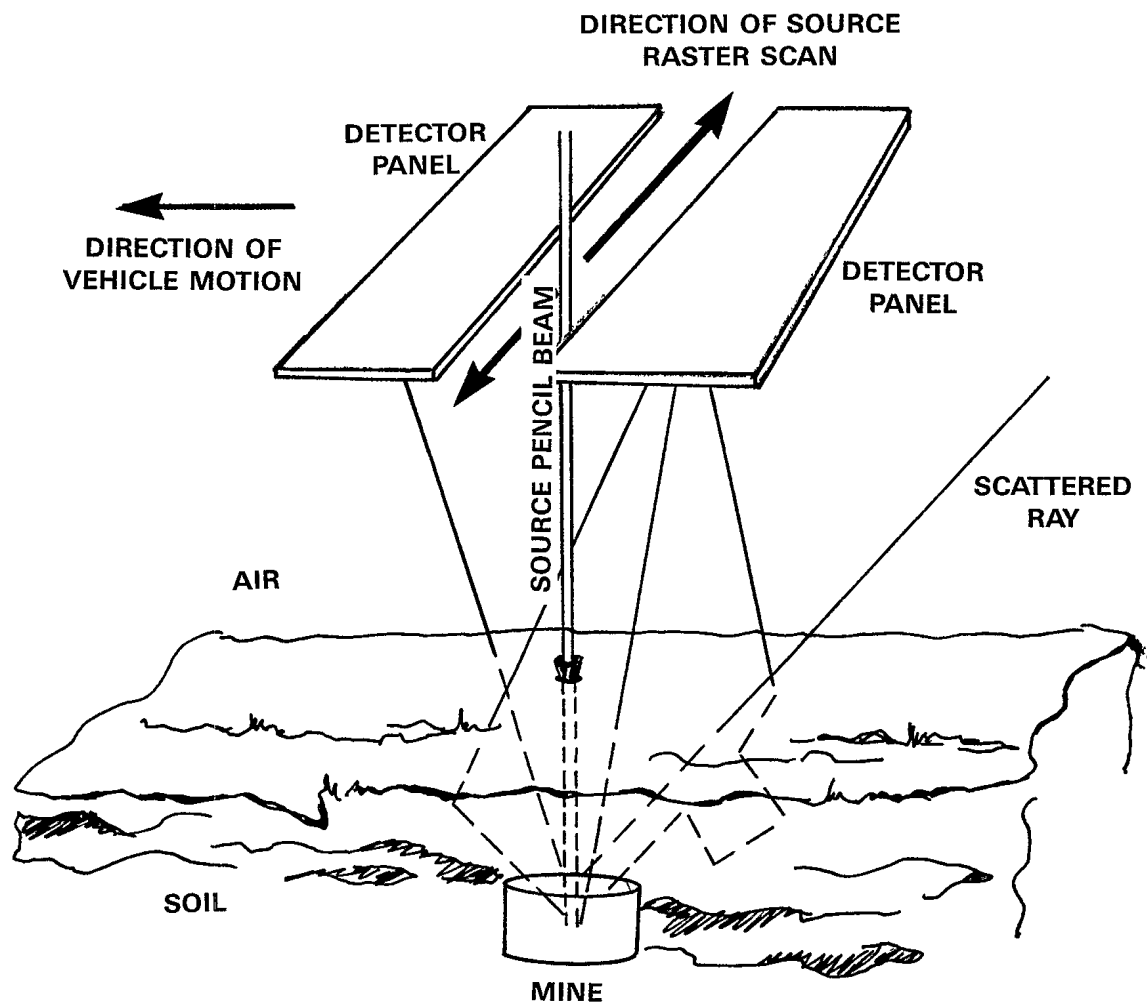

Figure 23

SCHEMATIC SYSTEM FOR A VEHICLE MOUNTED X-RAY BACKSCATTER NONMETALLIC MINE DETECTOR. DETAILS ARE GIVEN IN THE TEXT. ADAPTED FROM [60].

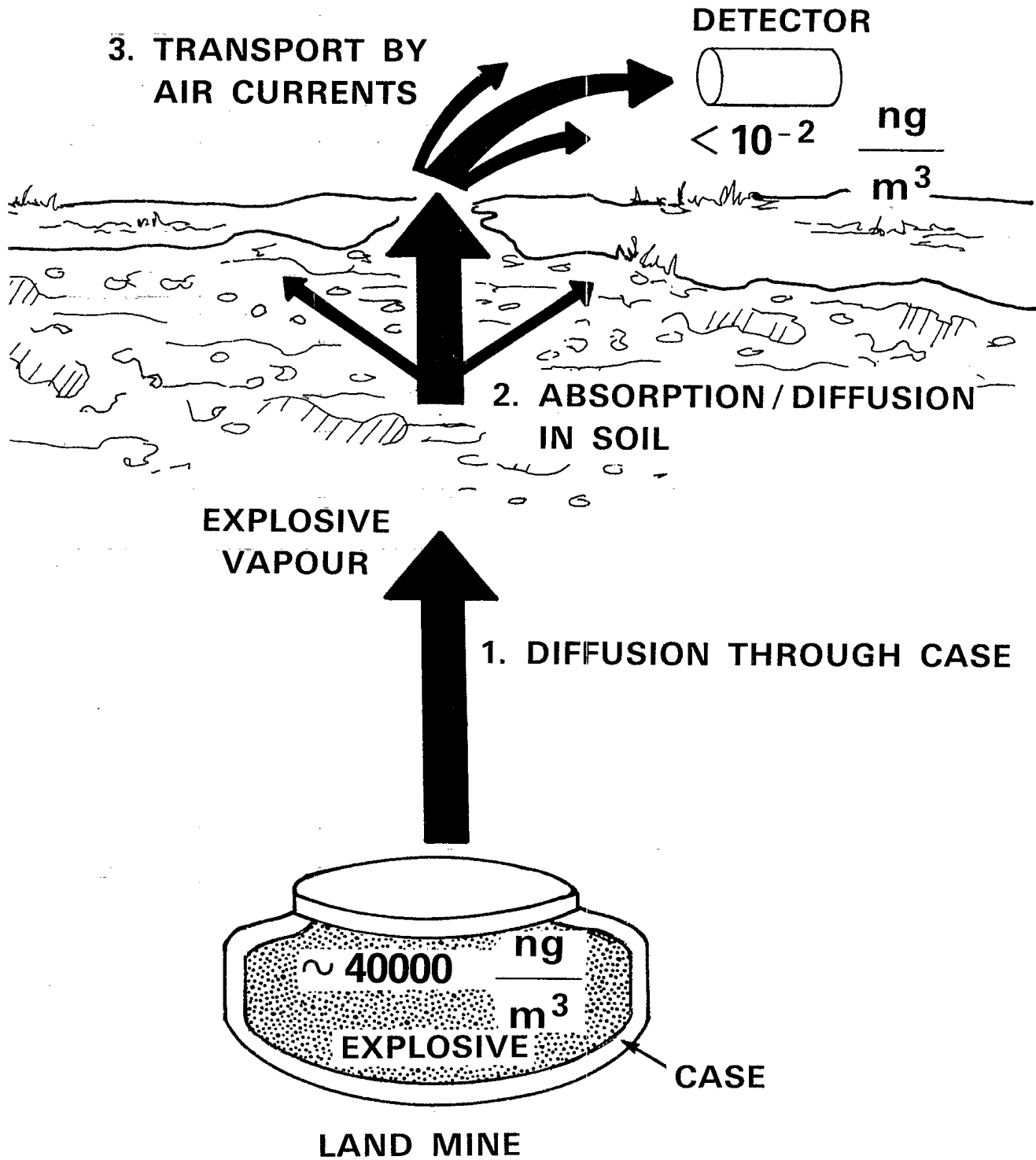

Figure 24

THE MECHANISMS WHICH EFFECT VAPOUR TRANSPORT FROM AN EXPLOSIVE MUNITION.

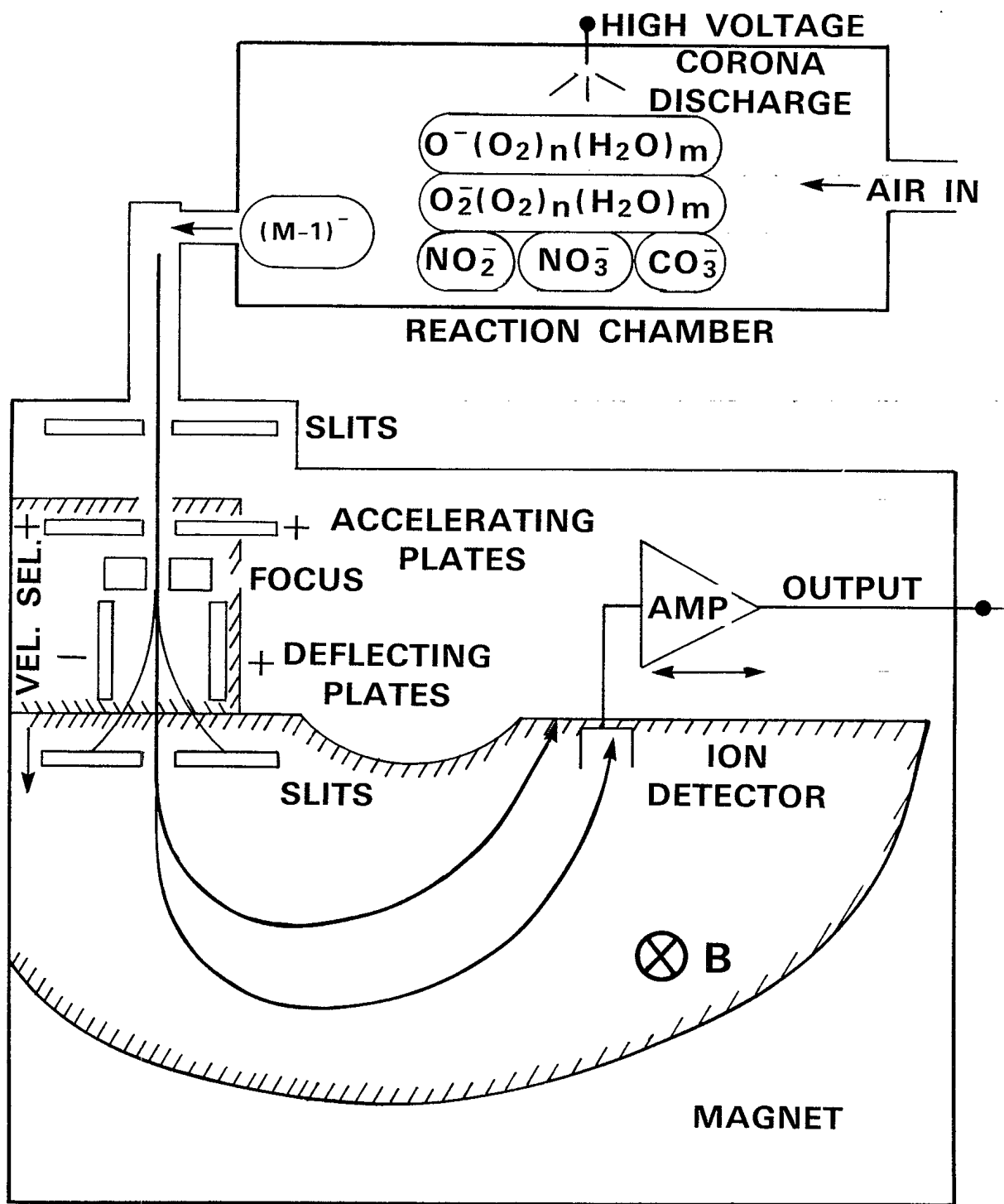

Figure 25

SCHEMATIC DIAGRAM OF AN ATMOSPHERIC PRESSURE CHEMICAL IONIZATION SOURCE MASS SPECTROMETER.

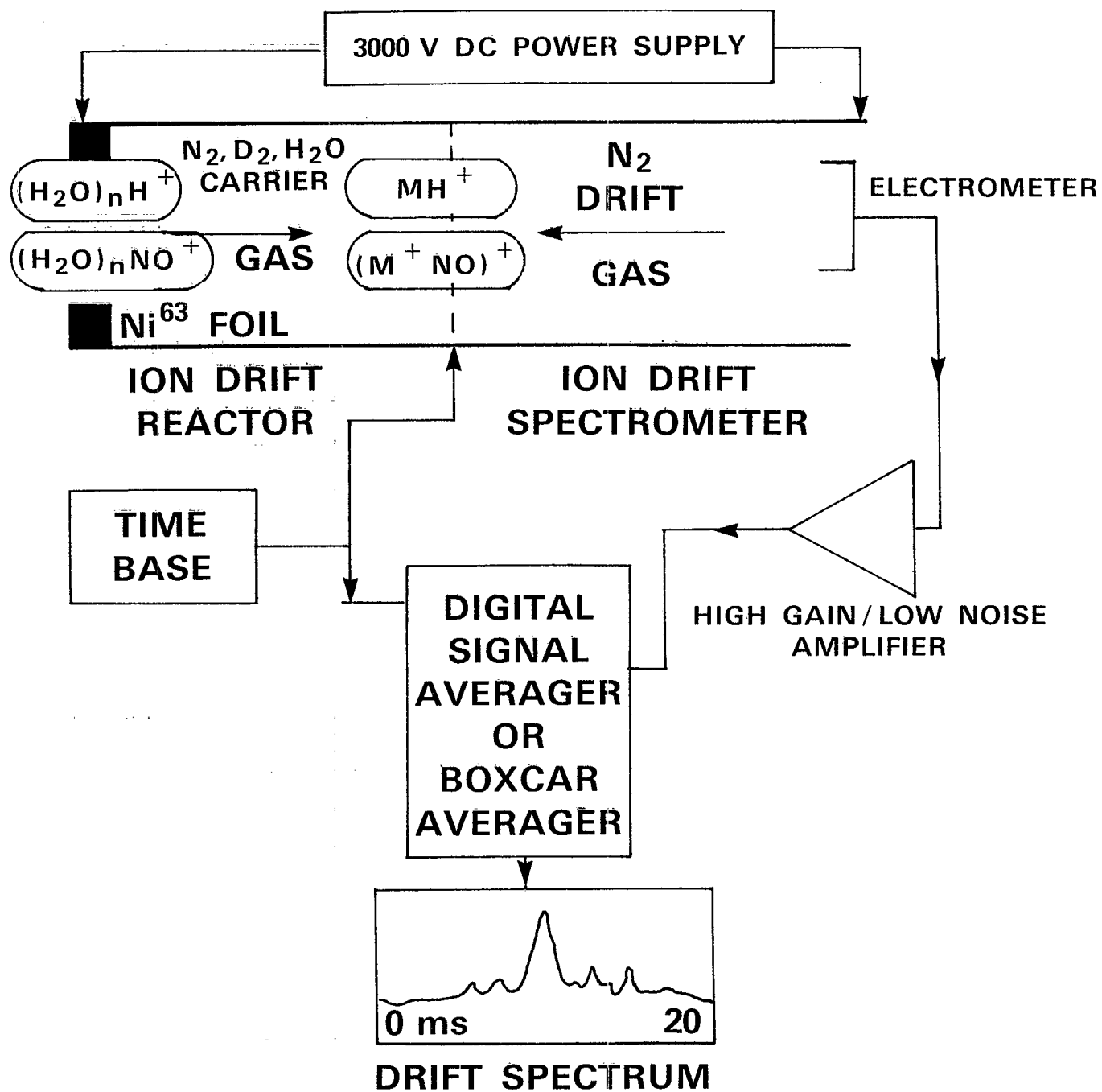

Figure 26

SCHEMATIC DIAGRAM OF AN ION MOBILITY SPECTROMETER.

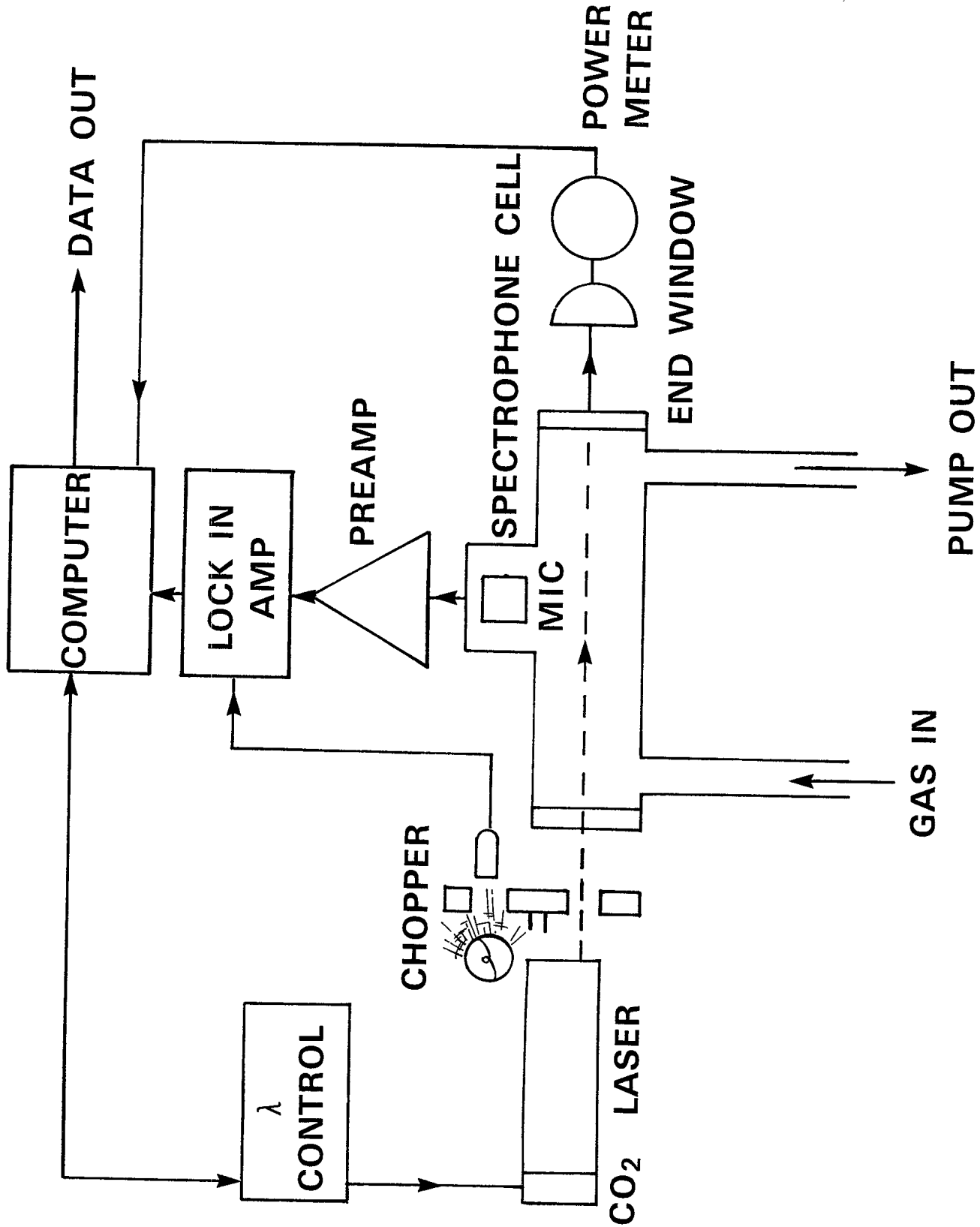

Figure 27

SCHEMATIC DIAGRAM OF A PHOTOACOUSTIC ABSORPTION TRACE GAS DETECTOR.

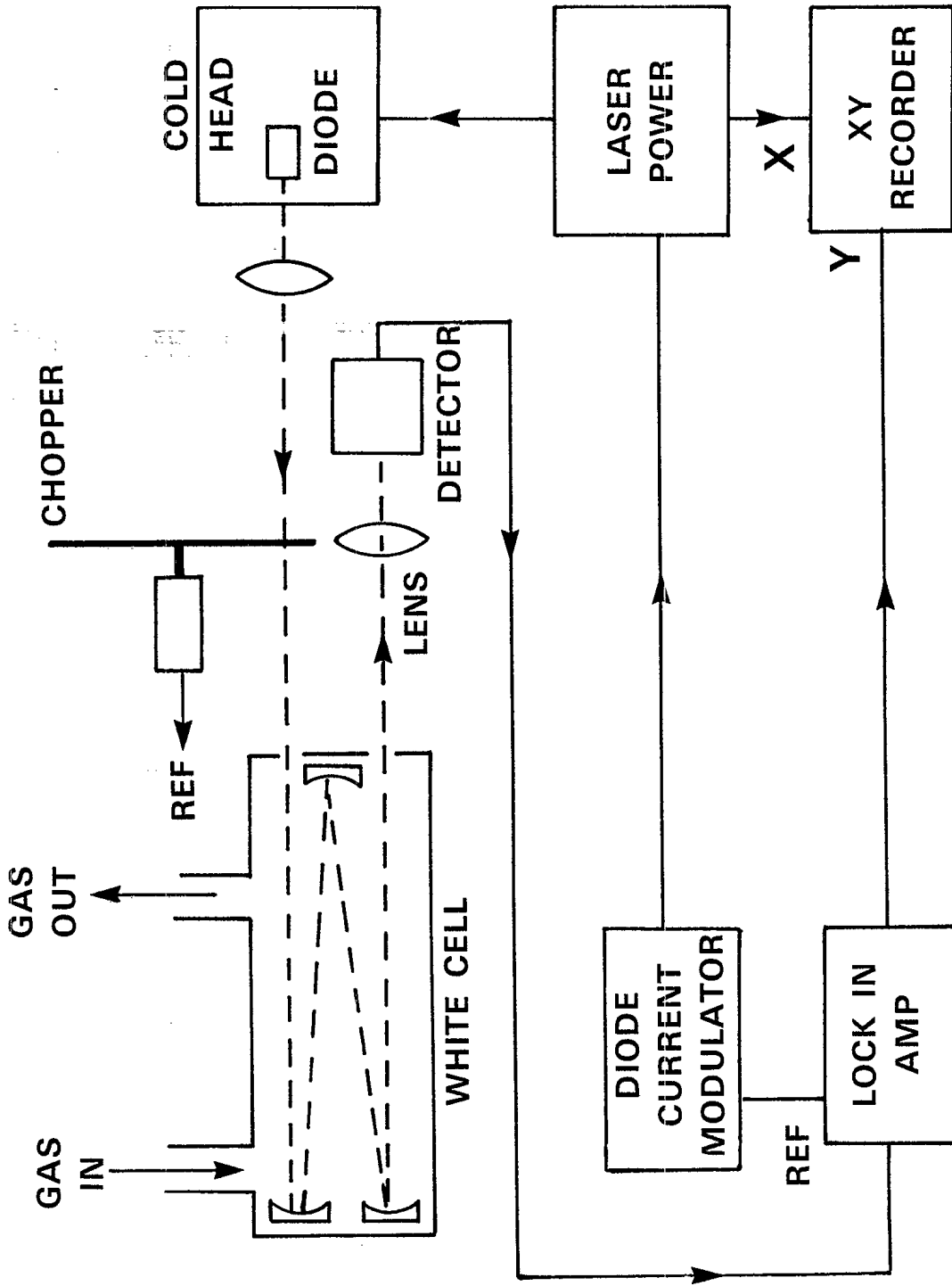

Figure 28

SCHEMATIC DIAGRAM OF A MULTIPATH CELL/TUNABLE DIODE LASER TRACE GAS DETECTOR.

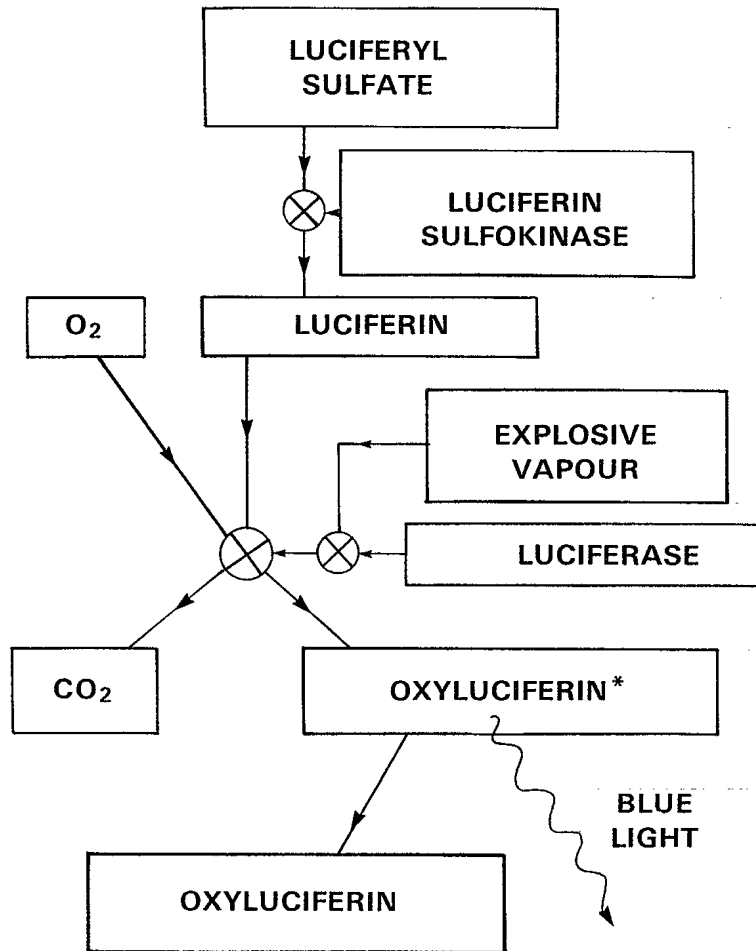
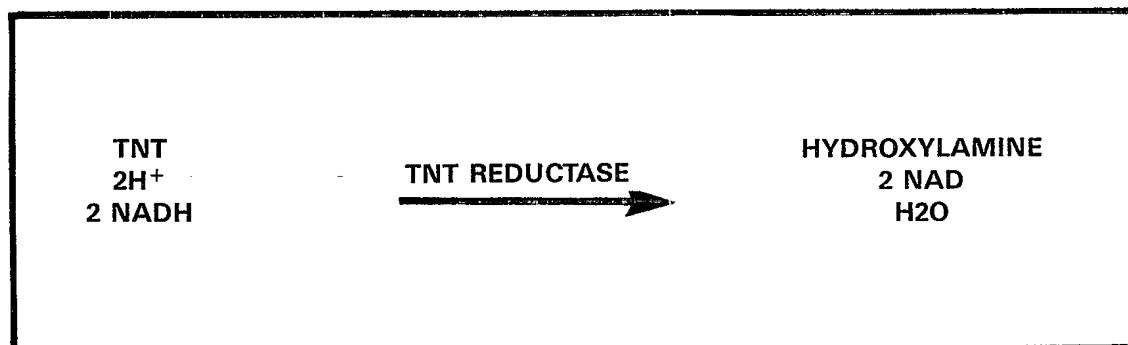
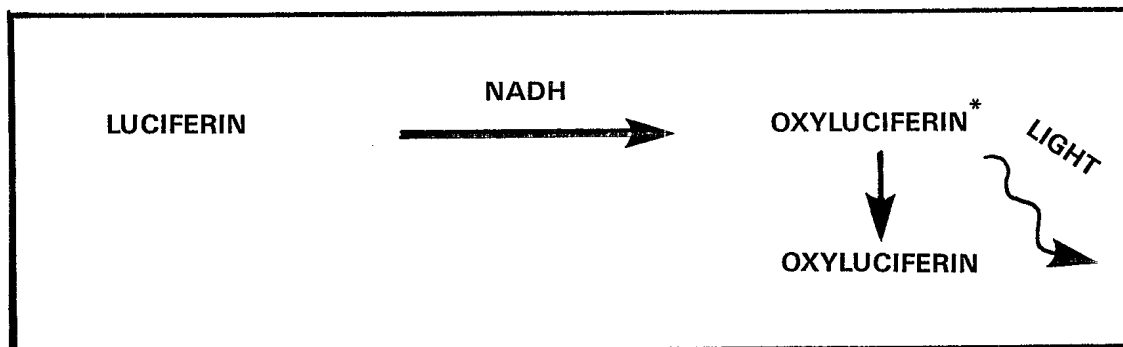

Figure 29

SCHEMATIC DIAGRAM OF THE INTERACTION OF EXPLOSIVE MOLECULES WITH THE BIOLUMINESCENCE REACTION CHAIN.



TNT DETECTION REACTION



INDICATOR REACTION

Figure 30

SCHEMATIC DIAGRAM OF ENZYMATIC TNT DETECTION.

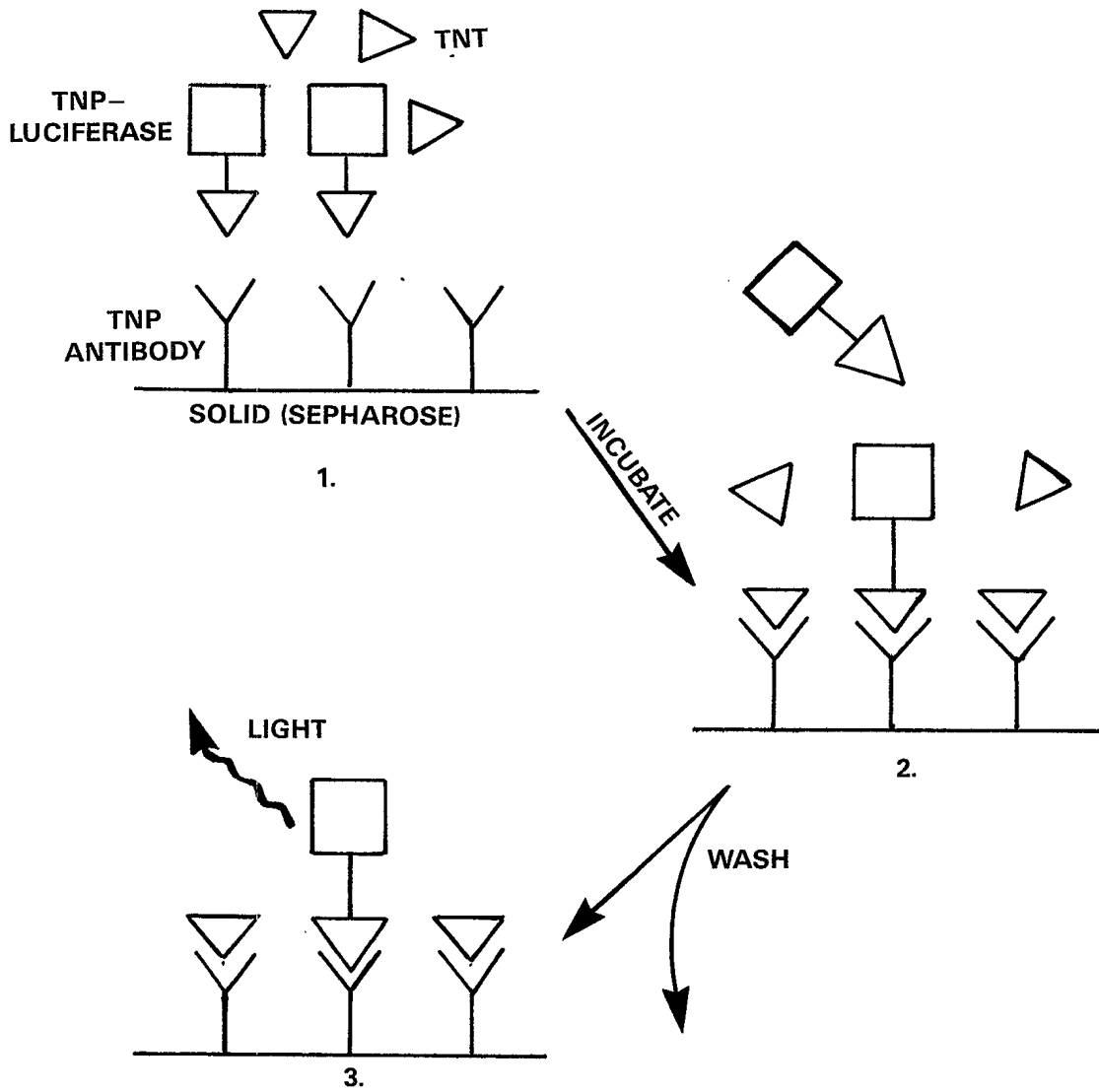

Figure 31

SCHEMATIC DIAGRAM OF THE IMMUNOASSAY METHOD FOR TNT DETECTION.

UNCLASSIFIED

SECURITY CLASSIFICATION OF FORM
(highest classification of Title, Abstract, Keywords)

DOCUMENT CONTROL DATA

(Security classification of title, body of abstract and indexing annotation must be entered when the overall document is classified)

<p>1. ORIGINATOR (the name and address of the organization preparing the document. Organizations for whom the document was prepared, e.g. Establishment sponsoring a contractor's report, or tasking agency, are entered in section 8.)</p> <p style="text-align: center;">Defence Research Establishment Suffield</p>	<p>2. SECURITY CLASSIFICATION (overall security classification of the document including special warning terms if applicable)</p> <p style="text-align: center;">UNCLASSIFIED</p>	
<p>3. TITLE (the complete document title as indicated on the title page. Its classification should be indicated by the appropriate abbreviation (S,C,R or U) in parentheses after the title.)</p> <p style="text-align: center;">Advances in the Location and Identification of Hidden Explosive Munitions (U)</p>		
<p>4. AUTHORS (Last name, first name, middle initial. If military, show rank, e.g. Doe, Maj. John E.)</p> <p style="text-align: center;">McFee, John E.; Das, Yogadhish</p>		
<p>5. DATE OF PUBLICATION (month and year of publication of document)</p> <p style="text-align: center;">February 1991</p>	<p>6a. NO. OF PAGES (total containing information. Include Annexes, Appendices, etc.)</p>	<p>6b. NO. OF REFS (total cited in document)</p>
<p>6. DESCRIPTIVE NOTES (the category of the document, e.g. technical report, technical note or memorandum. If appropriate, enter the type of report, e.g. interim, progress, summary, annual or final. Give the inclusive dates when a specific reporting period is covered.)</p>		
<p>8. SPONSORING ACTIVITY (the name of the department project office or laboratory sponsoring the research and development. Include the address.)</p>		
<p>9a. PROJECT OR GRANT NO. (if appropriate, the applicable research and development project or grant number under which the document was written. Please specify whether project or grant)</p>	<p>9b. CONTRACT NO. (if appropriate, the applicable number under which the document was written)</p>	
<p>10a. ORIGINATOR'S DOCUMENT NUMBER (the official document number by which the document is identified by the originating activity. This number must be unique to this document.)</p> <p style="text-align: center;">SR 548</p>	<p>10b. OTHER DOCUMENT NOS. (Any other numbers which may be assigned this document either by the originator or by the sponsor)</p>	
<p>11. DOCUMENT AVAILABILITY (any limitations on further dissemination of the document, other than those imposed by security classification)</p> <p><input checked="" type="checkbox"/> Unlimited distribution <input type="checkbox"/> Distribution limited to defence departments and defence contractors; further distribution only as approved <input type="checkbox"/> Distribution limited to defence departments and Canadian defence contractors; further distribution only as approved <input type="checkbox"/> Distribution limited to government departments and agencies; further distribution only as approved <input type="checkbox"/> Distribution limited to defence departments; further distribution only as approved <input type="checkbox"/> Other (please specify):</p>		
<p>12. DOCUMENT ANNOUNCEMENT (any limitation to the bibliographic announcement of this document. This will normally correspond to the Document Availability (11). However, where further distribution (beyond the audience specified in 11) is possible, a wider announcement audience may be selected.)</p> <p style="text-align: center;">Unlimited</p>		

UNCLASSIFIED

13. ABSTRACT (a brief and factual summary of the document. It may also appear elsewhere in the body of the document itself. It is highly desirable that the abstract of classified documents be unclassified. Each paragraph of the abstract shall begin with an indication of the security classification of the information in the paragraph (unless the document itself is unclassified) represented as (S), (C), (R), or (U). It is not necessary to include here abstracts in both official languages unless the text is bilingual).

A review of the state-of-the-art in detection of hidden explosive munitions is presented. Technologies have been divided into those that detect explosives directly and those that do not. For each technology, the physical principles, methodologies, strengths and weaknesses and probability of success are discussed. Methods that do not detect explosives include magnetostatics, electromagnetic induction, impedance tomography, electromagnetic radar, acoustics and optics. Methods that detect explosives include radiofrequency resonance absorption, nuclear radiation methods, trace gas detection and biochemical detection. Metallic munitions appear to be best detected using magnetostatics and electromagnetic induction. Most other methods should then be chiefly considered for detection of nonmetallic munitions or verification of detection of metallic munitions. Some nuclear methods are in use for detection of bombs in baggage and show some promise for nonmetallic mine detection. Nuclear magnetic resonance (NMR) has also been demonstrated to be able to detect bulk explosives in baggage and letters under practical constraints. The NMR detection of nonmetallic mines, although feasible, requires much more research. Trace gas detection shows promise for improvised explosive device (IED) detection but not for nonmetallic mine detection. Dogs and some small mammals are the only biodetectors which presently show promise for munition detection. In vitro biochemical detectors may eventually be useful for IED detection.

14. KEYWORDS, DESCRIPTORS or IDENTIFIERS (technically meaningful terms or short phrases that characterize a document and could be helpful in cataloging the document. They should be selected so that no security classification is required. Identifiers, such as equipment model designation, trade name, military project code name, geographic location may also be included. If possible keywords should be selected from a published thesaurus, e.g. Thesaurus of Engineering and Scientific Terms (TEST) and that thesaurus-identified. If it is not possible to select indexing terms which are Unclassified, the classification of each should be indicated as with the title.)

munitions landmines, UXO, unexploded ordnance, IED detection, improvised explosive devices, terrorist bombs
 location
 identification
 magnetostatics, magnetics, magnetometers
 electromagnetic induction
 impedance tomography
 conductivity imaging
 ground probing radar
 acoustics
 optical techniques
 nuclear techniques
 radiofrequency resonance absorption spectroscopy
 nuclear magnetic resonance
 electron spin resonance
 trace gas detection
 biochemical detection

91-01475
 #68682