



# RADON

## REDUCTION GUIDE FOR CANADIANS





**Health Canada is the federal department responsible for helping the people of Canada maintain and improve their health.** We assess the safety of drugs and many consumer products, help improve the safety of food, and provide information to Canadians to help them make healthy decisions. We provide health services to First Nations people and to Inuit communities. We work with the provinces to ensure our health care system serves the needs of Canadians.

Également disponible en français sous le titre :  
*Le radon : ce que vous devez savoir*

To obtain additional information, please contact:

Health Canada

Address Locator 0900C2

Ottawa, ON K1A 0K9

Tel.: 613-957-2991

Toll free: 1-866-225-0709

Fax: 613-941-5366

TTY: 1-800-465-7735

Email: [publications@hc-sc.gc.ca](mailto:publications@hc-sc.gc.ca)

This publication can be made available in alternative formats upon request.

© His Majesty the King in Right of Canada, as represented by the  
Minister of Health, 2023

Publication date: February 2023

This publication may be reproduced for personal or internal use only without  
permission provided the source is fully acknowledged.

**PUB.** 220824    **PRINT** Cat.: H129-40/2023E  
ISBN: 978-0-660-48183-8

**PDF** Cat.: H129-40/2023F-PDF  
ISBN: 978-0-660-48184-5



---

**Acknowledgments:**

Special thanks for their valuable comments to our stakeholder partners, Canadian Home Builders Association, National Research Council, the Canadian Association of Radon Scientists and Technologists and to the Kitigan Zibi Community for sharing their photos.



# INFORMATION FOR CANADIANS ON HOW TO REDUCE EXPOSURE TO RADON

## **DON'T IGNORE IT! RADON IS A SERIOUS HEALTH ISSUE**

Radon is a radioactive gas that you cannot see, smell or taste and can get into your home undetected. It is the second leading cause of lung cancer after smoking and the leading cause of lung cancer for non-smokers. When radon escapes from the ground into the outdoor air it is diluted to low concentrations and is no cause for concern. However, when radon enters an enclosed space, like a home, it can accumulate to high levels and become a health hazard. If the radon level in a home is high it can be easily fixed at a reasonable price. For more information on the risks from radon exposure see pages 2-8.

## **BE SURE TO DO A LONG-TERM TEST**

Almost all homes have some radon in them, the question is how much. The only way to know is to measure. Radon levels in a home can vary a lot from hour-to-hour and day-to-day, so the most accurate way to find out if you have a problem is to measure radon levels in your home for at least 3-month during the heating season (fall or winter). There are **two** options for testing a house for radon: one is to purchase a do-it-yourself long-term radon test kit and the other is to hire a certified radon measurement professional. For more information on radon testing see pages 9-11.



## **LOWER THE RADON LEVEL IN YOUR HOME, IT'S EASY**

If your radon level is high, reduce it! You should fix your home if your radon level is higher than the Canadian Guideline of 200 Becquerels per metre cubed (Bq/m<sup>3</sup>). **Reducing the amount of radon in your home is easy.** Techniques to lower radon levels are effective and can save lives. Radon levels in most homes can be reduced by more than 80% for about the same cost as other common home repairs such as replacing the furnace or air conditioner. For more information on reducing radon in your home see pages 15-33.

## **CHOOSE A CERTIFIED RADON MITIGATION PROFESSIONAL**

A certified radon mitigation contractor will make sure your home's radon level is lowered and your home is a healthier place to live. To find a certified mitigator, contact the Canadian National Radon Proficiency Program (C-NRPP) at **1-855-722-6777** or [info@cnrpp.ca](mailto:info@cnrpp.ca), the Canadian Association of Radon Scientists and Technologists (CARST) at [info@carst.ca](mailto:info@carst.ca) or Health Canada at [radon@hc-sc.gc.ca](mailto:radon@hc-sc.gc.ca). For more information on what you need to consider when choosing a radon mitigation contractor see pages 12-14.

## WHAT IS RADON?

Radon is a gas formed by the breakdown of uranium, a natural radioactive material found in all soil and rock. **Long-term exposure to radon is the 2nd leading cause of lung cancer after smoking and the leading cause of lung cancer for people who have never smoked.**



As radon breaks down it forms radioactive particles that can get lodged into your lung tissue as you breathe. The radon particles then release energy that can damage your lung cells. When lung cells are damaged, they have the potential to result in cancer. Not everyone exposed to radon will develop lung cancer, and the time between exposure and the onset of the disease can take many years.



## **RADON AND SMOKING**

The majority of lung cancer deaths are caused by smoking. Radon exposure is linked to approximately 16% of lung cancer deaths in Canada and is the second leading cause of lung cancer for smokers. If you smoke or have smoked and your home has high radon levels, your risk of lung cancer is especially high.

## **RADON LEVELS IN CANADIAN HOMES**

In 2009, Health Canada conducted a two-year study of radon concentrations in homes across Canada. This study found that:

- Approximately 7% of homes have high levels of radon
- Radon levels vary significantly across the country
- There are no areas of the country that are 'radon free,' but there are areas of the country where high levels of indoor radon are more prevalent

**No matter where your home is located, the only way to know if it has a high level of radon is to test.**

## **HOW RADON CAN ENTER YOUR HOME**

For most of the year, the air pressure inside your home is lower than the pressure in the soil surrounding your foundation. This difference in pressure can draw air and other gases in the soil, including radon, into the house.

Gas containing radon can enter your home at any opening where the house contacts the soil. These openings can be present even in well-built and new houses.

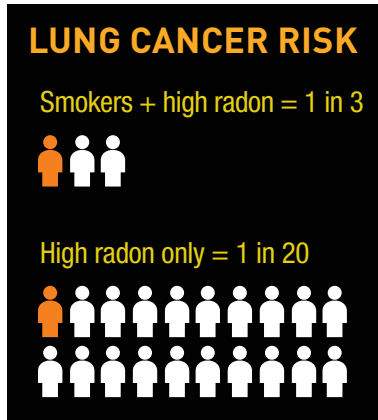



Potential entry routes for radon in homes with poured concrete foundations include cracks, areas with exposed soil or rocks, openings for utility fixtures or hollow objects such as support posts (see figure 1).

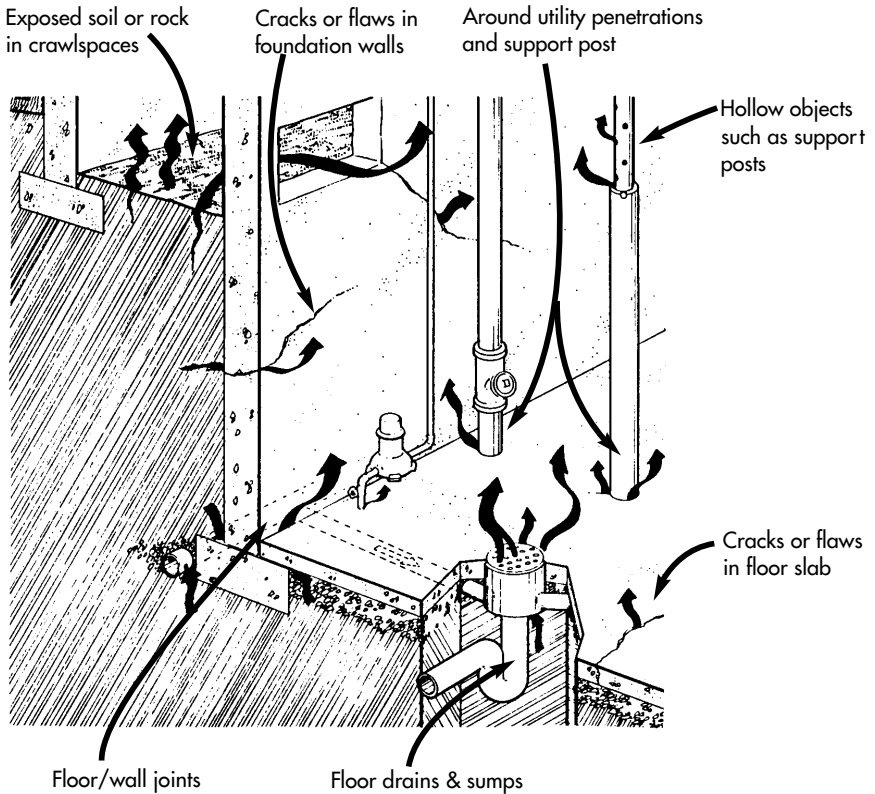

Figure 1 ↑  
Typical radon entry routes in poured concrete foundation walls and floors.

Homes with concrete block wall foundations can have other entry routes (see figure 2).

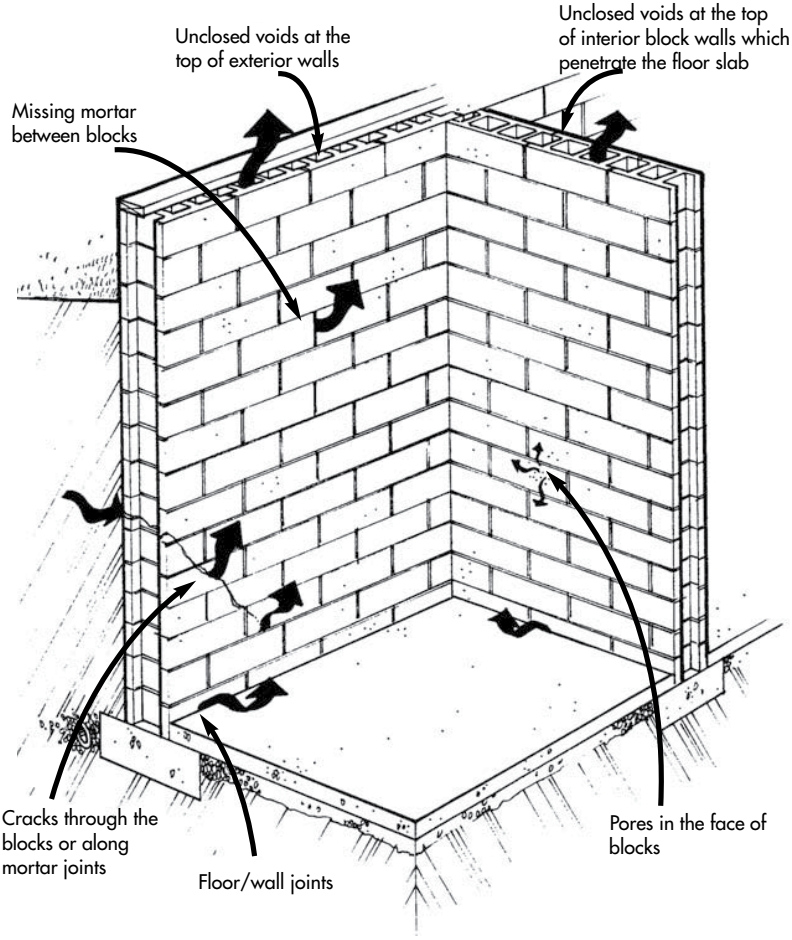

Figure 2 ↑  
Typical radon entry routes in concrete block foundation walls.

Homes with less common types of foundations (e.g., concrete slab-on grade, stone, or pressure-treated wood) may have other entry routes where openings or paths exist between the house and the ground. In many homes, regardless of the foundation type, some entry routes will be hidden or inaccessible. For example, they may be hidden by panelling, carpeting, appliances, wood framing or other objects.

Radon can also be found in groundwater from private or small community wells. Radon produced in the ground can dissolve and accumulate in water from underground sources such as wells. When water containing radon is agitated during daily household use – showering, clothes washing or cooking, for example – the radon gas can be released into the air. However, research has shown that drinking water that contains radon is far less harmful than breathing the gas. The health risk does not come from consuming the radon, but from inhaling the gas. And in most cases, the risk of radon entering the home through water is much lower than if it enters through the ground.

Materials used to construct a house – stones, bricks, cement, or granite, for example – are not a significant source of radon in Canada. Natural materials taken from the ground, like granite, can contain some uranium and may have higher levels of radiation or radon than you would expect, but in the vast majority of cases these levels are not significant. In February 2010, Health Canada completed a study of 33 types of granite commonly purchased in Canada and none were found to have significant levels of radon.

## **WHICH HOMES HAVE A PROBLEM?**

Almost all homes have some radon. The levels can vary dramatically even between similar homes located next to each other.

The amount of radon in a home will depend on many factors including:

- **Soil Characteristics:** Radon concentrations can vary enormously depending on the uranium content of the soil. As well, radon flows more easily through some soils than others, for example sand versus clay.
- **Construction Type:** The type of home and its design affect the amount of contact with the soil and the number and size of entry points for radon.



- **Foundation Condition:** Foundations with numerous cracks and openings have more potential entry points for radon.
- **Occupant Lifestyle:** The use of exhaust fans, windows and fireplaces, for example, influences the pressure difference between the house and the soil. This pressure difference can draw radon indoors and influences the rate of exchange of outdoor and indoor air.
- **Weather:** Variations in weather (e.g., temperature, wind, barometric pressure, precipitation, etc.) can affect the amount of radon that enters a home.



Because there are so many factors, it is not possible to predict the radon level in a home; the only way to know for sure is to test.

## DO I NEED TO REDUCE THE RADON LEVEL IN MY HOME?

If you've tested your home, and the radon level is above the Canadian guideline of 200 Bq/m<sup>3</sup>, Health Canada recommends that you take action to lower the level. The higher the radon concentrations, the sooner action should be taken to reduce levels to as low as practically possible.

**While the health risk from radon exposure below the Canadian Guideline is small there is no level that is considered risk free. It is the choice of each homeowner to decide what level of radon exposure they are willing to accept.**



200 - 600 Bq/m<sup>3</sup>  
fix your home  
within 2 years



Above 600 Bq/m<sup>3</sup>  
fix your home  
within 1 year

## MEASURING THE RADON LEVEL IN YOUR HOME

Radon levels in a home change significantly over time. They can rise and fall from one hour or day to the next and seasonally. For this reason, measurements taken over a longer period of time are more accurate. Health Canada recommends that homeowners do a long-term radon test, for a minimum of three months, during the fall or winter and that the detector is placed in the lowest level of the home, where homeowners spend a minimum of 4 hours per day. A three-month test represents a person's annual average exposure and should be used to determine if a home's radon concentration exceeds the Canadian guideline level of 200 Bq/m<sup>3</sup>. To find a do-it-yourself radon test kit go to [www.takeactiononradon.ca/test](http://www.takeactiononradon.ca/test).

Radon test kits can be purchased by phone, from the internet, or in person from certain certified professionals, local community health organizations or home improvement retailers.

### If you use a do-it-yourself radon test kit:

- remember to send the detector to the lab once the three month testing period is over, and
- be sure to write down the test start and stop time and date.

If you hire someone to measure the radon level in your home, make sure they are certified under the Canadian National Radon Proficiency Program (C-NRPP). For a list of certified measurement professionals please call 1-855-722-6777 or go to [www.c-nrpp.ca](http://www.c-nrpp.ca).



## THE LONG-TERM RADON DETECTORS MOST COMMONLY USED IN CANADA ARE:



### ALPHA TRACK DETECTOR

These detectors use a small piece of special plastic enclosed in a container. The detector is exposed to the air in a home for a specified time. After the radon in the air enters the chamber, the alpha particles (i.e., the type of radiation associated with radon) strike the plastic and cause damage tracks; the number of tracks is proportional to the radon concentration. At the end of the test the detector is returned to a laboratory for analysis, and the average radon concentration is calculated.



### ELECTRET ION CHAMBER

This detector contains a disk called an “electret,” which has an electrostatic charge housed in a container. When the detector is exposed to the air in a home for a specified time, the radon in the air enters the container and the ionization produced by alpha particles (i.e., the type of radiation associated with radon) reduce the electret charge”. This can be done in the home, or the detector can be returned to a laboratory for measurement.



## SHORT-TERM MEASUREMENTS

When you need a fast measurement of the radon concentration – for example, to check how a mitigation system is working – a short-term measurement of two to seven days is acceptable. However, short-term measurements should never be used to determine if the radon concentration in a home exceeds the Canadian Guideline or to assess the need for remedial actions. The result of any short-term measurement should be confirmed with a follow-up long-term measurement made at the same location.

**Digital Radon Monitors** for short- and long-term testing are also available on the market, however, Health Canada cannot recommend their use because they have not yet been evaluated and approved by the Canadian National Radon Proficiency Program (C-NRPP).

More information on radon measurement can be found in Health Canada’s radon measurement guides for homes and public buildings:



### Homes:

<https://www.canada.ca/en/health-canada/services/publications/health-risks-safety/guide-radon-measurements-residential-dwellings.html>

### Buildings:

<https://www.canada.ca/en/health-canada/services/environmental-workplace-health/reports-publications/radiation/guide-radon-measurements-public-buildings-schools-hospitals-care-facilities-detention-centres.html>



# DEALING WITH CONTRACTORS FOR RADON REDUCTION

## WHY HIRE A CERTIFIED PROFESSIONAL?

If radon levels in your home are above the Canadian guideline, Health Canada recommends that you hire a professional certified under the Canadian National Radon Proficiency Program (C-NRPP). Lowering radon levels in a home requires specific technical knowledge and skills to ensure the job is done properly.

Choose a contractor to fix a radon problem just as you would choose someone to do other home renovations or repairs. It is wise to get more than one estimate if possible, and to ask for references. Contact some of those references to ask if they are satisfied with the contractors' work. Be sure to get a written cost estimate that outlines all of the work to be carried out.

To find a list of certified professionals contact the Canadian National Radon Proficiency Program (C-NRPP) at 1-855-722-6777, go to [www.c-nrpp.ca](http://www.c-nrpp.ca) or email [radon@hcc-sc.gc.ca](mailto:radon@hcc-sc.gc.ca).

More information on the Canadian National Radon Proficiency certification training and programs is available online at: [www.c-nrpp.ca](http://www.c-nrpp.ca).





## Before hiring a professional to address the radon problem in your home, ask the following questions:

- How many homes has the contractor worked on to reduce radon levels? Were any of these homes similar to yours? Will the contractor provide references or photographs?
- Can the contractor provide proof of C-NRPP certification?
- Did the contractor inspect your home's structure before giving you an estimate?
- Did the contractor review the quality of your radon measurement results and determine if appropriate testing procedures were followed?
- Did the contractor explain what the work will involve, how long it will take to complete, and exactly how the radon reduction system will work?
- Will the contractor perform any diagnostic tests to help determine what type of radon reduction system should be used and where it should be placed in the home?
- Will the contractor include the installation of a warning device to caution you if the radon reduction system is not working correctly?
- Will the contractor provide a guarantee that they will reduce the radon level to a pre-determined maximum?

It is important to remember that the lowest quote may not be your best choice. A very low bid may simply mean that the contractor has made a mistake or does not know enough about the work to estimate properly and may not complete the job properly. Make sure the contractors are certified for radon mitigation and that the various bids cover the same work. If the proposed work differs, ask the contractors to explain why.



## THE CONTRACT

Once you have chosen a C-NRPP-certified professional, the next step is to ask for a contract based on their proposal.

Read the contract carefully before you sign it. Make sure everything in the contract matches the original proposal. The contract should describe exactly what radon reduction method will be used in your home, how a system will operate, and what work will be done as part of the job. Many contractors will provide a guarantee that they will adjust or modify a system to reach a specified radon level, so make sure you read and understand the conditions describing this guarantee. Carefully consider optional additions to your contract; while they may add to the initial cost of the system, they may be worth the extra expense. Typical options might include an extended warranty, a service plan, and/or improved aesthetics.

### Important information that should appear in the contract includes:

- name, address, telephone and C-NRPP certification number of the contractor;
- name, address, and telephone numbers of any sub-contractors;
- total cost of the job, including all taxes and permit fees; how much, if any, is required for a deposit; and when payment is due in full;
- amount of time needed to complete the work;
- a statement that liability insurance and applicable workers' compensation coverage is carried by the contractor to protect you in the event of injury to persons or damage to property while the work is being carried out;
- a commitment that the contractor will patch holes, clean-up after the job, and take responsibility for any incidental damage;
- details of warranties or guarantees; and
- a description of what the homeowner is expected to do (e.g., make the work area accessible).

## REDUCING RADON IN HOMES

When selecting a radon reduction method for your home, you and your contractor should consider several things, including:

- the radon level in your home;
- the costs of installation and system operation;
- your home's size and foundation type.

The effectiveness of any one radon-reduction method will depend upon the unique characteristics of your home, the level of radon, how it is getting into your house, and how thoroughly the job is done. A single method may do the job, but sometimes a combination of several methods must be used.

Homes are generally categorized according to their foundation design: basement, slab-on-grade, or crawlspace. Some homes have more than one foundation design feature: a basement under one part of the home and a slab-on-grade or crawlspace in another area. In these situations a combination of radon-reduction techniques may be needed to reduce radon levels to below the Canadian guideline.

A certified radon professional will likely perform one or more **diagnostic tests** to help determine the best radon-reduction system for your home. For example, your contractor may use chemical smoke to see the air flow sources and radon entry points by watching a small amount of smoke that has been placed into holes, drains, sumps or along cracks. Another type of diagnostic test is a Pressure Field Extension Test (or communication test). This test uses a vacuum cleaner (e.g., a Shopvac) to measure how easily air can move from one point to another under the foundation and estimate the number of suction points and fan size needed for an active radon-reduction system.



Health Canada, working with experts in the field of radon mitigation, created a guide to provide professional building contractors with information on techniques for reducing radon levels in homes in contact with soil. The guide, *Reducing Radon Levels in Existing Homes: A Canadian Guide for Professional Contractors*, is based on the best and most current information available. A pdf copy of the guide can be ordered from Health Canada by email at [radon@hc-sc.gc.ca](mailto:radon@hc-sc.gc.ca).

## ACTIVE SOIL DEPRESSURIZATION

### ACTIVE SUB-SLAB DEPRESSURIZATION

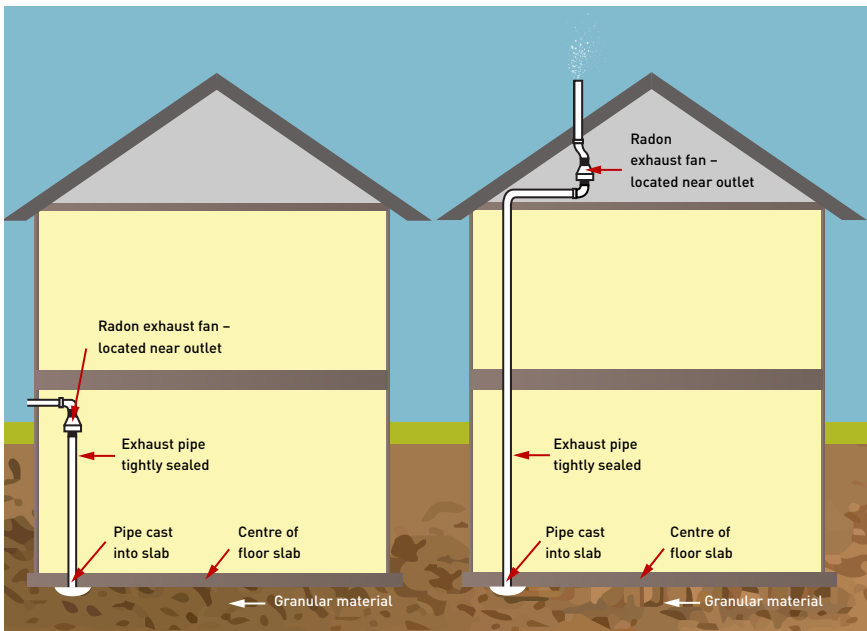

Sub-slab depressurization (also called active soil depressurization) is the most effective and reliable radon reduction technique. It is also the most common method used by C-NRPP certified professionals.

This method involves installing a pipe through the foundation floor slab and attaching a fan that runs continuously to draw the radon gas from below the home and release it into the outdoors where it is quickly diluted. This system also reverses the air pressure difference between the house and soil, reducing the amount of radon that is drawn into the home through the foundation. One, or sometimes multiple, suction points are inserted through the floor slab into the crushed rock or soil underneath to effectively reduce the radon level in the home.

The sub-slab depressurization pipe can be vented at either the roof level or ground level of the home. The fan can be placed in the basement or an area outside of the living space such as in a garage or attic. If the fan is placed inside the living space of the home, it is usually vented sideways through the rim joist at ground level, with the fan close to the exhaust location. When the fan is placed outside of the living space (e.g. attic or garage) then it is typically vented upwards above the roof.

In many Canadian climates, a fan and pipe located outside the living space (garage or attic) will cool during the colder months of the year, leading to condensation and possibly ice, which can damage the fan and affect the effectiveness of the radon-reduction system.

Condensation problems can be reduced if the fan is placed indoors and the exhaust is discharged from a shorter pipe near ground level at right angles to the wall, much like the power vented exhausts from combustion appliances such as natural gas-fired water heaters.





If the fan is placed inside the home, it is important to confirm with your contractor that it is air tight and that all pipes and plumbing joints have been sealed. Properly installed fans and pipes will not leak radon into the building and are usually installed in the basement. When the fan and pipe are placed inside the home and combined with a ground level discharge, almost the entire system is located indoors, which helps to avoid problems that can arise from cold climates.

Current field test studies of indoor mounted fans with near ground level discharges show this is an effective technique. Further field testing of this system in urban environments where houses are built in close proximity to each other is necessary. To verify continued performance of any radon-reduction system, an initial long-term measurement should be made within two years of the system activation and at five-year intervals afterwards.



When any active depressurization system is installed, it is recommended to make sure that its operation does not cause backdrafting of combustion appliances such as a furnace, water heater, fireplace, or wood stove in the home. Backdrafting can happen when a room with a combustion appliance is depressurized so much that smoke and combustion gases spill into the home instead of venting outdoors. Backdraft testing may be done by a trained radon-reduction specialist or a heating contractor.

## SUMP-HOLE DEPRESSURIZATION

A variation of active sub-slab depressurization is **active sump-hole depressurization**. Often, when a home with a basement has a sump pump to remove unwanted water, the sump can be capped and sealed so that it can continue to drain water and also serve as the location for a radon suction pipe. If a basement floor drain is connected to the sump, a mechanical trap seal device or water trap should be installed to prevent house air from entering the sump via the drain.



## DRAINAGE SYSTEM DEPRESSURIZATION

Some homes have drain tiles or perforated pipe to direct water away from the foundation of the home. Suction on these tiles or pipes can be effective in reducing radon levels, especially for a block wall foundation. This method, called **drainage system depressurization**, is worth considering if it is *certain* the tile forms a complete loop around the foundation. This type of system will be less effective if only a small area of the basement perimeter is covered.



## **HOMES WITH CRAWLSPACES: ACTIVE SUB-MEMBRANE DEPRESSURIZATION**

The soil in a crawlspace can be vented using a similar technique called active sub-membrane depressurization. It involves laying a thick plastic sheet (often a polyethylene membrane) over the soil, sealing the air-tight membrane to the foundation walls and placing a pipe with fan through it to draw the radon from under the plastic sheet and vent it to the outdoors. For this method to be effective, special attention is needed to seal around the pipe where it penetrates the plastic sheet.

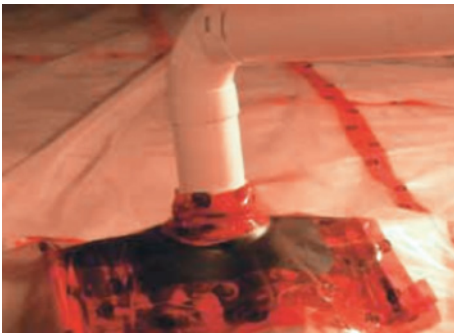

Sub-slab or sub-membrane depressurization systems range in cost from about \$2,000 to \$3,000 including material and labour. There is also a small operating cost for electricity for the fan, approximately \$50 to \$75 a year, depending on size of fan and energy rates.

When large radon reductions (50 per cent or more) are desired, active soil depressurization is almost always the recommended approach. If smaller reductions are sufficient, the other radon reduction methods described below may be reasonable alternatives. A certified radon professional can help you determine the best solution for your home.



## OTHER RADON REDUCTION METHODS

### SEALING MAJOR ENTRY ROUTES FOR RADON

Sealing off openings in a home where radon could be entering may help to lower radon levels in your home. However, because it is difficult to identify, access and permanently seal all openings **it is not a standalone technique for reducing radon levels.**

Major openings that can be important to seal include:

**Open sumps** – Sumps can be fitted with an airtight cover. If the sump also acts as a floor drain, add a special trap to the airtight cover and slightly recess the cover into the sump.



**Floor drains** – Basement floor drains can have special traps installed that allow water to drain, but prevent radon from entering the basement. These traps have the added benefit of keeping out molds, odours, insects and cold drafts.

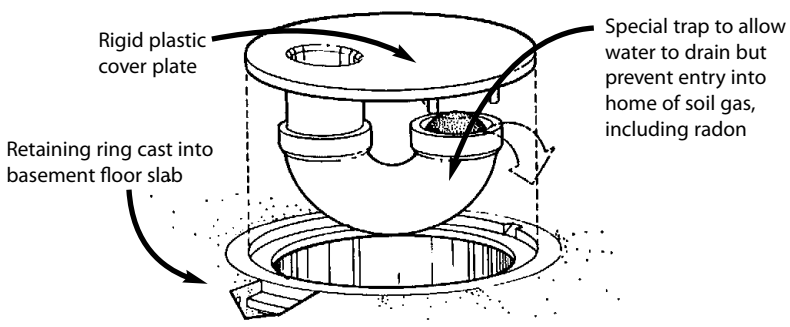



**Floor Wall Joint** - If accessible, the joint between the foundation wall and basement floor can be sealed. This joint can be a major contributor to the radon levels in a home.

Proper surface preparation is critical for a good seal – follow caulking manufacturer's instructions

Fill crack with polyurethane caulking

Use an Ethafoam™ backing rod to create a more durable seal

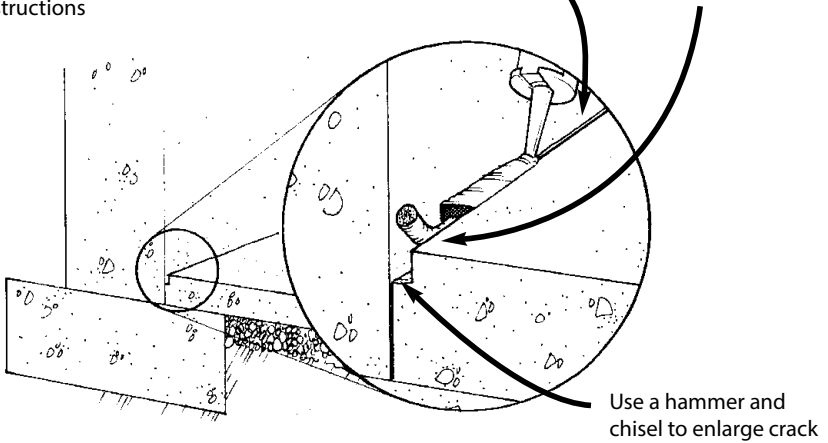

Figure 3 ↑  
Sealing foundation wall and basement floor joint.

**Exposed soil** – Exposed soil in crawl spaces can be covered by a plastic membrane with sealed edges and joints. If there are significant areas in a basement where no floor slab exists (e.g., cold storage room), concrete can also be poured to cover any exposed soil once a membrane has been installed.

**Voids in concrete block walls** – If there isn't a solid row of block, seal voids in the top of foundation and interior load-bearing walls.

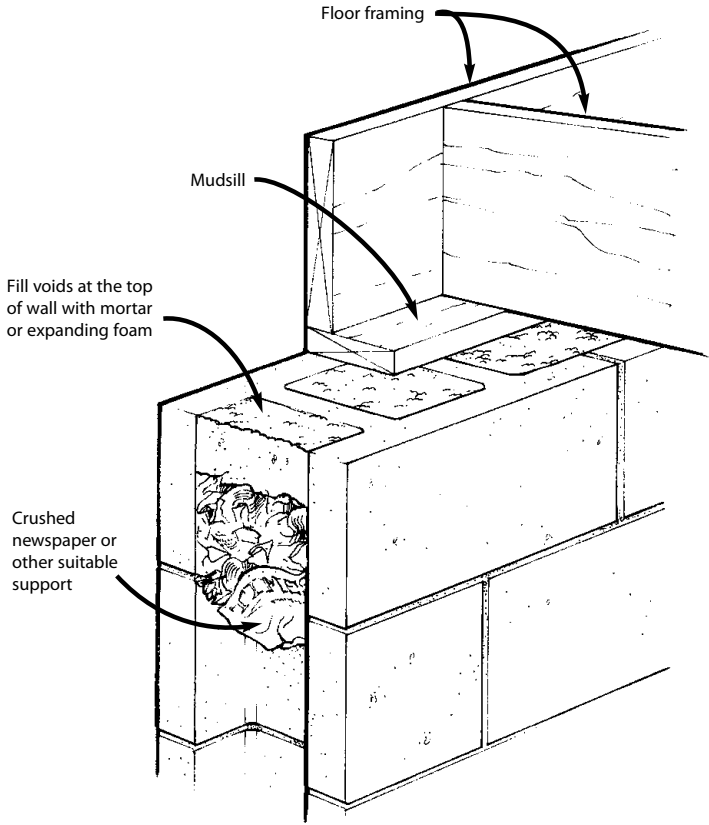



Figure 4 †  
Sealing voids in the top of concrete block walls.

After closing major openings, a further reduction in radon levels can sometimes be achieved by sealing minor entry routes that are visible or accessible. Minor cracks in foundation walls and floors can be sealed. Larger cracks require special techniques; consult your building material



supplier or a contractor. The gap around utility penetrations (e.g., water, sewer, electrical, natural gas, fuel oil) in walls and floors can also be sealed.

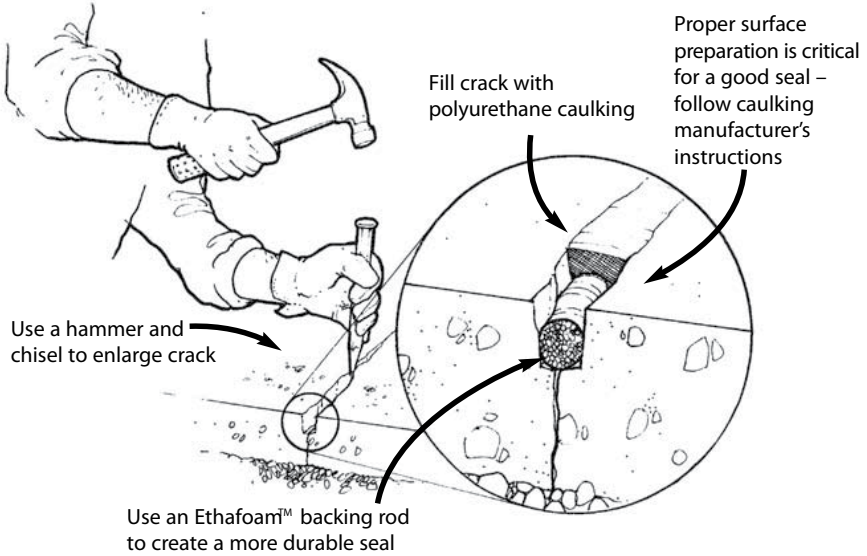
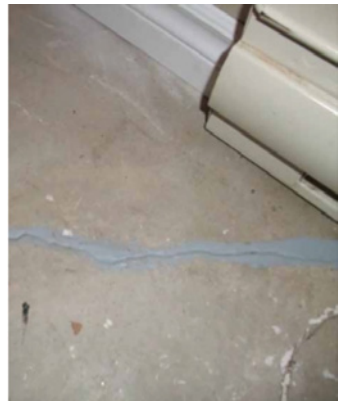

Figure 5 ↑  
Sealing foundation wall and floor cracks.

Sealing cracks and other openings in the foundation is a basic part of most approaches to radon reduction and can help increase their effectiveness. Proper preparation of the surface area to be sealed is extremely important to create an effective and long lasting seal.



The cost of sealing entry routes is highly variable. It can range from a few hundred dollars to \$2,000 or more. Although the material cost is relatively low, it is very labour-intensive to do a comprehensive job. As the house ages and settles, the seals can deteriorate, and new cracks or entry routes can appear. As a result, there will be an ongoing cost to maintain the seals.

### **INCREASING MECHANICAL VENTILATION OF THE HOME**

A heat recovery ventilator (HRV) or energy recovery ventilator (ERV) can be installed to increase ventilation, which will help reduce the radon levels in your home. An HRV increases ventilation by introducing outdoor air as it uses the heated or cooled air being exhausted to warm or cool the incoming air. It is important to ensure that this type of system has balanced intake and exhaust air flows so that the house is not depressurized, which can draw in more radon.



The effectiveness of ventilation for radon reduction is limited and only appropriate for situations where only modest reductions are needed. In general, increased ventilation methods for radon reduction will be most successful in houses that are more airtight and have low natural ventilation rates (are not 'drafty'). It is also important that the HRVs are properly balanced and maintained (i.e. check filters). In most homes, an HRV might reduce radon levels by 25 to 50 per cent.

An HRV will cost between \$1,500 and \$3,500 (material and labour). There is also an operating cost for electricity for the HRV's fans as well as an increase in heating and cooling costs due to greater ventilation of the home.



Mitigation Options - Poured Concrete and Slab-on-grade Foundations				
Foundation Type	Poured Concrete		Slab-on-grade	
Foundation Floor	Exposed soil/pavers	Concrete slab	Exposed soil (building extension)	Concrete slab
Mitigation Options				
Close large openings to soil in any accessible parts of foundation walls/floor.	<input checked="" type="checkbox"/>	<input checked="" type="checkbox"/>		<input checked="" type="checkbox"/>
Trap floor drains that lead to soil.	<input checked="" type="checkbox"/>	<input checked="" type="checkbox"/>		<input checked="" type="checkbox"/>
Cover soil water drain sump and exhaust it to outside.	<input checked="" type="checkbox"/>	<input checked="" type="checkbox"/>		<input checked="" type="checkbox"/>
Isolate foundation area from living area.	<input checked="" type="checkbox"/>	<input checked="" type="checkbox"/>	<input checked="" type="checkbox"/>	
Exhaust foundation area air to outside.*				
Isolate foundation area from living area.	<input checked="" type="checkbox"/>	<input checked="" type="checkbox"/>	<input checked="" type="checkbox"/>	
Install Heat Recovery Ventilator to supply fresh air to living area, and exhaust foundation area air to outside*.				
Install Heat Recovery Ventilator to supply fresh air to living area, and exhaust from bathroom or furnace area to outside*.				<input checked="" type="checkbox"/>
Cover accessible area of exposed soil/pavers with plastic membrane, exhaust from beneath to outside*.	<input checked="" type="checkbox"/>		<input checked="" type="checkbox"/>	
Exhaust from beneath concrete slab to outside*.		<input checked="" type="checkbox"/>	<input checked="" type="checkbox"/>	

\* Caution – Back-drafting of combustion appliances possible. e.g. Wood stove, oil/gas furnace, oil/gas water heater.

## FOLLOW-UP RADON TESTING

When a radon reduction system is first activated, the contractor should make sure seals and joints are working effectively and correct any faults or defects found. The contractor should place a label on the system listing when it was activated, and the suggested re-test intervals. The suction and flow in the piping should be measured and noted on the label for comparison when the system fan is serviced.

It is recommended that a certified C-NRPP professional carry out a short-term test after a system is activated to demonstrate that it is working effectively. The test should be started at least 24 hours after the fan is turned on. The radon test should ideally be in the same location where the measurements were originally made.

The homeowner should also ensure that a long-term three-month test is performed the following fall /winter season to confirm that the annual average radon level has been reduced to below the Canadian guideline. To avoid conflict of interest, the test should not be performed by the company that installed the radon mitigation system.

### CHANGE IN RADON CONCENTRATION AFTER MITIGATION

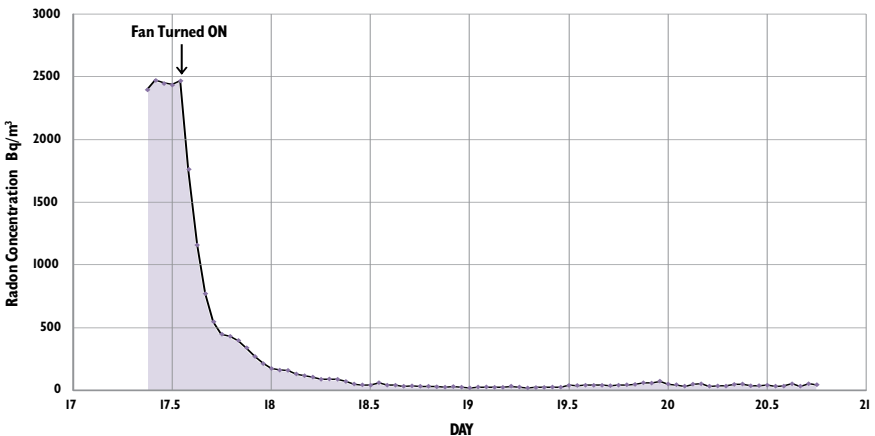



## PREVENTING RADON PROBLEMS IN NEW HOMES

It is not possible to predict before construction whether or not a new home will have high radon levels. Fortunately, preventive measures can be taken by your builder during the design and construction process to reduce the amount of radon that gets into the home and make it easier to install a radon reduction system, if required.

The 2010 National Building Code (NBC) includes requirements that address radon. Parts five and six of the code require that engineers and designers consider radon protection in their designs and ensure control of air leakage and soil gas entry to minimize the level of radon entering a home through the foundation.

Part nine of the code includes consolidating air barrier requirements such as a sealed plastic membrane under the foundation slab, and requiring that every building have granular fill under the slab and a rough-in for a future radon reduction system, should the need for radon reduction later arise.

Many provinces have adopted or are in the process of adopting these 2010 National Building Codes. Homeowners should ask their builders if they include building practices that help reduce radon entry (sealed membrane) and make it easier for radon removal (rough-in for a radon reduction system) if necessary.

### **BUILDERS CAN MINIMIZE RADON ENTRY INTO THE HOME BY:**

- Installing a plastic membrane (polyethylene or equivalent polyolefin) air barrier under the foundation slab. The membrane should be a minimum of 10 mil in thickness with taped seams and be gas and puncture resistant.
- Sealing the basement floor/foundation wall expansion joint. There are several options for sealing this potential radon entry point. Note that proper preparation of surfaces to be caulked is critical to obtain an effective, long-lasting seal. (see figure 3, page 21)
- Sealing around all objects that penetrate foundation walls and basement floors, including utility lines for water, sewer, electrical, natural gas, or fuel oil. The centre of hollow objects that penetrate the walls or floors (e.g., metal support posts or masonry for fireplaces) should also be sealed or blocked.



- Providing proper curing conditions. Moistening the slab or coating it with a special compound during curing will result in stronger, more durable concrete. If the weather is hot and dry or below freezing, your contractor must take appropriate precautions to ensure the cement is cured properly.
- Using control joints in the concrete floor slab. While some cracks in the basement slab may be unavoidable, your contractor can direct cracks into controlled locations where they can be sealed.
- Installing special traps in floor drains that allow water to drain but prevent radon from entering the basement (see floor drain image on page 20).
- Using a sealed lid on the sump. Your builder may either purchase a sealed unit or field fabricate a sealed lid (See open sump image on page 20).



The actions mentioned above can help reduce the amount of radon that enters a home but do not guarantee that annual average radon levels will be below the Canadian guideline of 200 Bq/m<sup>3</sup>.

Three levels of radon control measures for new housing construction are described in the [Health Canada Guide for Radon Measurements in Residential Dwellings](#) listed in order of increasing effectiveness at minimizing radon ingress that will reduce radon levels in homes post-occupancy. These include:

- **Level 1** – Radon gas barrier and rough-in (current National Building Code 2010 radon measures)
- **Level 2** – Full vertical passive radon stack;
- **Level 3** – Full active soil depressurization system



## MAINTAINING YOUR RADON REDUCTION SYSTEM

As with a furnace or air conditioner, radon reduction systems need occasional maintenance. If you have a fan-powered depressurization system, you should look at your system performance-indicating device, usually a manometer, on a regular basis to make sure the system is working correctly. A U-tube manometer is used as an indicator that the mitigation system is working. The manometer is filled with a liquid and indicates pressure or flow.

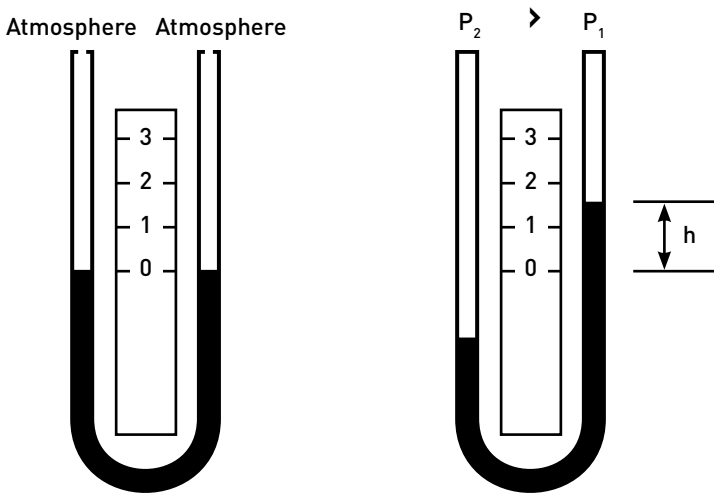

Figure 7 ↑  
U-tube manometer.

The image on the left shows the level on both sides of the u-tube is the same, indicating that the mitigation system is not working properly. The image on the right, which shows a higher level on one side of the u-tube, shows a pressure difference, which indicates the system is working properly. Minor variations in the level can be expected. The level in the manometer should be checked from time to time. Ask your certified radon reduction expert to show you how to check if the fan is working properly and follow the instructions that are supplied with the U-tube manometer.

Remember, the fan should NEVER be turned off; it must run continuously for the system to work properly. The lifespan of a fan can vary between five to ten or more years. Replacement cost ranges between \$200 and \$300.

The filter in a Heat Recovery Ventilator (HRV) requires periodic cleaning and should be changed twice a year. Replacement filters for an HRV are easy to change and reasonably priced. Ventilation systems should be checked annually by a heating, ventilating and air conditioning professional to make sure the air flow remains properly balanced. HRVs used for radon control should run all the time. Also, vents that bring outdoor air into the home must be inspected regularly for leaves and other debris.

## **REMODELLING YOUR HOME AFTER RADON LEVELS HAVE BEEN LOWERED**

If you decide to make major structural changes to your home, including, for example, converting an unfinished basement area into living space or a creating a new foundation for an addition after you have had a radon reduction system installed, ask your radon contractor what should be done to help ensure that radon levels throughout the home continue to be reduced. After you remodel, retest in the least lived-in area to make sure the construction did not reduce the effectiveness of the radon reduction system.



## WHERE TO GET MORE INFORMATION

### **Radiation Protection Bureau Health Canada**

775 Brookfield Road  
A/L 6302A  
Ottawa, ON K1A 1C1

Toll Free: 1-833-723-6600  
e-mail: [radon@hc-sc.gc.ca](mailto:radon@hc-sc.gc.ca)

## FURTHER SOURCES OF INFORMATION

**Health Canada website** – [www.canada.ca/radon](http://www.canada.ca/radon)

**Canadian Association of Radon Scientists and Technologists (CARST)**  
e-mail: [info@carst.ca](mailto:info@carst.ca)

**Canadian National Radon Proficiency Program (C-NRPP)**  
e-mail: [info@c-nrpp.ca](mailto:info@c-nrpp.ca)  
Telephone: 1-855-722-6777