

# Safety Issues and Concerns of Forced Air Deicing Systems



Prepared for

**Transportation Development Centre**  
On behalf of  
**Civil Aviation**  
**Transport Canada**

and

**The Federal Aviation Administration**  
**William J. Hughes Technical Center**



November 2000

# Safety Issues and Concerns of Forced Air Deicing Systems



by

**Peter Dawson**



November 2000

The contents of this report reflect the views of APS Aviation Inc. and not necessarily the official view or opinions of the Transportation Development Centre of Transport Canada or other sponsors.

The Transportation Development Centre does not endorse products or manufacturers. Trade or manufacturers' names appear in this report only because they are essential to its objectives.

### DOCUMENT ORIGIN AND APPROVAL RECORD

Prepared by:	 Peter Dawson Consultant	<u>25 Sep 2002</u> Date
--------------	---	----------------------------

Reviewed by:

  
John D. Avirro  
Program Manager

Aug 20, 2002  
Date

Approved by:

  
Gilles Nappert  
Quality Manager, ISO

19 Aug 2002  
Date

Un sommaire français se trouve avant la table des matières.

## PREFACE

At the request of the Transportation Development Centre of Transport Canada, APS Aviation Inc. has undertaken a research program to advance aircraft ground de/anti-icing technology. The specific objectives of the APS test program are the following:

- To develop holdover time data for Type IV fluids using lowest-qualifying viscosity samples, and to develop holdover time data for all newly-qualified de/anti-icing fluids;
- To conduct flat plate holdover time tests under conditions of frost;
- To further evaluate the flow of contaminated fluid from the wing of a Falcon 20 D aircraft during simulated takeoff runs;
- To determine the patterns of frost formation and of fluid failure initiation and progression on the wings of commercial aircraft;
- To evaluate whether the proposed locations of Allied Signal's wing-mounted ice sensors on an Air Canada CL65 are optimally positioned;
- To evaluate the second generation of the NCAR snowmaking system;
- To evaluate the capabilities of ice detection camera systems;
- To examine the feasibility of and procedures for performing wing inspections with remote ice detection camera system at the entrance to the departure runway (end-of-runway);
- To reassemble and prepare the JetStar aircraft wing for mounting, to modify it to obtain cold-soak capabilities, and to conduct fluid failure tests in natural precipitation using the wing;
- To extend hot water deicing tests to aircraft in natural outdoor precipitation conditions, and to correlate outdoor data with 1998-99 laboratory results;
- To examine safety issues and concerns of forced air deicing systems; and
- To evaluate snow weather data from previous winters to establish a range of snow precipitation suitable for the evaluation of holdover time limits.

The research activities of the program conducted on behalf of Transport Canada during the 1999-2000 winter season are documented in nine reports. The titles of these reports are as follows:

- TP 13659E Aircraft Ground De/Anti-icing Fluid Holdover Time and Endurance Time Testing Program for the 1999-2000 Winter;
- TP 13660E Aircraft Full-Scale Test Program for the 1999-2000 Winter;
- TP 13661E A Second-Generation Snowmaking System: Prototype Testing;

- TP 13662E Ice Detection Sensor Capabilities for End-of-Runway Wing Checks: Phase 2 Evaluation;
- TP 13663E Hot Water Deicing of Aircraft: Phase 2;
- TP 13664E Safety Issues and Concerns of Forced Air Deicing Systems;
- TP 13665E Snow Weather Data Evaluation (1995-2000);
- TP 13666E Contaminated Aircraft Simulated Takeoff Tests for the 1999-2000 Winter: Preparation and Procedures; and
- TP 13667E Preparation of JetStar Wing for Use in Deicing Research.

This report, TP 13664E, has the following objective:

- To examine safety issues and concerns of forced air deicing systems.

This objective was met by conducting a series of tests on one forced air system in a cold chamber laboratory. The safety concerns examined included noise intensity, effect on visibility, projectiles, pressure on wing skin, heat on wing skin, residue in quiet areas, elapsed time to refreezing, and shearing of Type IV fluid.

## ACKNOWLEDGEMENTS

This research has been funded by the Civil Aviation Group, Transport Canada, with support from the U.S. Federal Aviation Administration. This program could not have been accomplished without the participation of many organizations. APS would therefore like to thank the Transportation Development Centre of Transport Canada, the Federal Aviation Administration, National Research Council Canada, Atmospheric Environment Services Canada, and several fluid manufacturers. Special thanks are extended to US Airways Inc., Air Canada, the National Centre for Atmospheric Research, AéroMag 2000, Aéroports de Montreal, G. Vestergaard A/S, Hudson General Aviation Services Inc., Union Carbide, Cryotech, BFGoodrich, Cox and Company Inc., Fortier Transfert Ltée, and MTN Snow Equipment Inc. for provision of personnel and facilities and for their co-operation with the test program. The author gratefully acknowledges the participation of Elio Ruggi, Medhat Hanna, Jeff Mayhew, Jennifer Kelly, and Phillip LeBlanc. Special thanks are extended to Frank Eyre and Barry Myers of the Transportation Development Centre for their participation, contribution, and guidance in the preparation of this document. APS would also like to acknowledge the dedication of the research team, whose performance was crucial to the acquisition of hard data.



1. Transport Canada Publication No. <b>TP 13664E</b>		2. Project No. <b>9789</b>		3. Recipient's Catalogue No.		
4. Title and Subtitle <b>Safety Issues and Concerns of Forced Air Deicing Systems</b>				5. Publication Date <b>November 2000</b>		
				6. Performing Organization Document No. <b>CM1589.001</b>		
7. Author(s) <b>Peter Dawson</b>				8. Transport Canada File No. <b>ZCD2450-23-14 (DC-182)</b>		
9. Performing Organization Name and Address <b>APS Aviation Inc. 1100 René Lévesque Blvd. West Suite 1340 Montreal, Quebec Canada H3B 4N4</b>				10. PWGSC File No. <b>XSD-9-01714</b>		
				11. PWGSC or Transport Canada Contract No. <b>T8200-9-9563/001/XSD</b>		
12. Sponsoring Agency Name and Address <b>Transportation Development Centre (TDC) 800 René Lévesque Blvd. West Suite 600 Montreal, Quebec H3B 1X9</b>				13. Type of Publication and Period Covered <b>Final</b>		
				14. Project Officer <b>B. Myers</b>		
15. Supplementary Notes (Funding programs, titles of related publications, etc.) <b>Research reports produced on behalf of Transport Canada for testing during previous winters are available from the Transportation Development Centre (TDC). Nine reports (including this one) were produced as part of this winter's research program. Their subject matter is outlined in the preface.</b>						
16. Abstract <p>A research program was conducted to examine safety implications of forced air deicing systems. These include the potential for injury to personnel, the potential for damage to aircraft and the ability to provide a clean aircraft for takeoff. Trials were conducted at the National Research Council Canada Climatic Engineering Facility on a commercial forced air deicing system.</p> <p>The trials examined:</p> <ul style="list-style-type: none"> <li>• noise intensity generated by the forced air equipment;</li> <li>• effect on visibility when removing snow and ice;</li> <li>• tendency of the forced air deicing system to dislodge chunks of snow or ice and to fling them some distance and height;</li> <li>• pressure exerted by the air stream on the skin of the aircraft;</li> <li>• effect on aircraft skin temperature;</li> <li>• elapsed time following deicing before refreezing occurred;</li> <li>• residue in quiet areas; and</li> <li>• shearing of Type IV fluid applied with the air stream.</li> </ul> <p>It was concluded that the potential for injury to personnel and for damage to aircraft was no greater than with the standard form of deicing. The use of forced air alone (with the equipment as tested) is not recommended for either the first step of a two-step deicing procedure or as a one-step procedure. The air/fluid combination as tested is not a feasible alternative during snowfall and cold outside air temperature, for either the first step of a two-step deicing procedure or as a one-step procedure.</p> <p>The limited heat transfer to the wing surface is believed to be a major contributing factor to the shorter times to refreeze as compared to the standard method. The thickness and condition of the fluid film resulting from the air/fluid method should be examined in any future tests.</p>						
17. Key Words <b>Forced air deicing system, heat transfer, one-step deicing procedure, two-step deicing procedure</b>				18. Distribution Statement <b>Limited number of copies available from the Transportation Development Centre</b>		
19. Security Classification (of this publication) <b>Unclassified</b>		20. Security Classification (of this page) <b>Unclassified</b>		21. Declassification (date) <b>—</b>	22. No. of Pages <b>xxiv, 100, apps</b>	23. Price <b>Shipping/ Handling</b>



1. N° de la publication de Transports Canada <b>TP 13664E</b>		2. N° de l'étude <b>9789</b>		3. N° de catalogue du destinataire		
4. Titre et sous-titre <b>Safety Issues and Concerns of Forced Air Deicing Systems</b>				5. Date de la publication <b>Novembre 2000</b>		
				6. N° de document de l'organisme exécutant <b>CM1589.001</b>		
7. Auteur(s) <b>Peter Dawson</b>				8. N° de dossier - Transports Canada <b>ZCD2450-23-14 (DC-182)</b>		
9. Nom et adresse de l'organisme exécutant <b>APS Aviation Inc. 1100, boul. René-Lévesque Ouest Bureau 1340 Montréal, Québec Canada H3B 4N4</b>				10. N° de dossier - TPSGC <b>XSD-9-01714</b>		
				11. N° de contrat - TPSGC ou Transports Canada <b>T8200-9-9563/001/XSD</b>		
12. Nom et adresse de l'organisme parrain <b>Centre de développement des transports (CDT) 800, boul. René-Lévesque Ouest Bureau 600 Montréal (Québec) H3B 1X9</b>				13. Genre de publication et période visée <b>Final</b>		
				14. Agent de projet <b>B. Myers</b>		
15. Remarques additionnelles (programmes de financement, titres de publications connexes, etc.) <p>Les rapports de recherche produits au nom de Transports Canada sur les essais réalisés au cours des hivers antérieurs peuvent être obtenus auprès du Centre de développement des transports (CDT). Le programme de la saison hivernale a donné lieu à neuf rapports (dont celui-ci). On trouvera dans la préface l'objet de ces rapports.</p>						
16. Résumé <p>Un programme de recherche a été lancé dans le but d'examiner les incidences sur la sécurité des systèmes de dégivrage à air forcé. Les sujets étudiés comprennent les risques de blessures au personnel et de dommages à l'avion, et la capacité du système de débarrasser un avion de toute contamination avant le décollage. Des essais ont eu lieu dans l'Installation de génie climatique du Conseil national de recherches du Canada, sur un système de dégivrage à air forcé commercial.</p> <p>Les essais ont porté précisément sur ce qui suit :</p> <ul style="list-style-type: none"><li>• le niveau de bruit généré par les équipements de soufflage d'air forcé;</li><li>• l'effet sur la visibilité de l'enlèvement de neige et de givre;</li><li>• la tendance du système de dégivrage à air forcé à projeter à une certaine distance et en hauteur les morceaux de neige ou de givre délogés des surfaces;</li><li>• la pression exercée par le courant d'air sur le revêtement de l'avion;</li><li>• l'effet du courant d'air sur la température du revêtement de l'avion;</li><li>• le temps écoulé entre la fin du dégivrage et l'apparition des premiers signes de givrage;</li><li>• les résidus de contamination dans les zones à inertie aérodynamique;</li><li>• le cisaillement du liquide de type IV injecté dans le courant d'air forcé.</li></ul> <p>L'étude a révélé que les risques de blessures au personnel et de dommages à l'avion ne sont pas plus grands qu'avec les méthodes de dégivrage classiques. Mais le recours à l'air forcé seul (avec l'équipement qui a servi à l'essai), n'est pas recommandé, que ce soit en tant que première étape d'une procédure de dégivrage à deux étapes ou en tant que procédure à une seule étape. De plus, l'injection de liquide de dégivrage dans le courant d'air forcé, telle que mise à l'essai, n'est pas une solution de rechange réaliste lorsqu'il neige et que la température extérieure est basse, que ce soit en tant que première étape d'une procédure de dégivrage à deux étapes ou en tant que procédure à une seule étape.</p> <p>Le peu de chaleur transféré à la surface de l'aile expliquerait en grande partie pourquoi le givrage réapparaît plus rapidement que lorsqu'une méthode de dégivrage classique est employée. Si d'autres essais étaient entrepris, il y aurait lieu d'étudier l'épaisseur et l'état de la couche de liquide déposée sur les surfaces lorsque du liquide est injecté dans le courant d'air.</p>						
17. Mots clés <b>Système de dégivrage à air forcé, transfert de chaleur, procédure de dégivrage à une étape, procédure de dégivrage à deux étapes</b>				18. Diffusion <b>Le Centre de développement des transports dispose d'un nombre limité d'exemplaires.</b>		
19. Classification de sécurité (de cette publication) <b>Non classifiée</b>		20. Classification de sécurité (de cette page) <b>Non classifiée</b>		21. Déclassification (date) <b>—</b>	22. Nombre de pages <b>xxiv, 100, ann.</b>	23. Prix <b>Port et manutention</b>

## EXECUTIVE SUMMARY

At the request of the Transportation Development Centre of Transport Canada and the U.S. Federal Aviation Administration, APS Aviation undertook a research program to examine the safety implications of forced air deicing systems.

### Background

Airlines have shown increased interest in the use of forced air deicing to blow frozen contaminants off an aircraft surface, corresponding to the development by several manufacturers of forced air systems mounted on conventional deicing vehicles. It is expected that a number of airlines will employ forced air deicing systems during the 2000-01 winter season.

The methodology of using forced air as an integral part of the deicing operation has not yet evolved, and standard operating procedures are still in development.

Some forced air deicing systems use high-pressure air or an air/fluid mix, while others are based on delivering large air volumes at low pressure. Some nozzle arrangements deliver air at a very high speed from the nozzle. A columnar air stream can be maintained over an extended distance to lengthen the effective reach of the high-speed air stream. Other designs demonstrate a very rapid decrease in speed of the air stream after it exits the nozzle. The air stream exiting the nozzle may be hotter than the ambient air because of the heat of compression.

Because the use of forced air systems is a relatively new process, safety implications – including the potential for injury to personnel, the potential for damage to aircraft, and the ability to provide a clean aircraft for takeoff – are a primary concern.

### Forced Air Deicing Concepts

Incorporation of forced air deicing into the deicing process can conceivably take any of several forms:

- Using forced air alone or with injected Type I fluid to remove most of the contamination from aircraft surfaces prior to deicing with heated fluid.

This approach may reduce subsequent deicing times and fluid quantities; it does not attempt or claim to provide a clean wing for takeoff.



- Using forced air alone or with injected Type I fluid as the first step of a two-step procedure.

This application must produce a clean aircraft surface and the surface must remain uncontaminated long enough for application of a second step anti-icing fluid. The minimum interval is generally accepted to be 3 minutes.

- Using forced air with injected SAE Type I fluid as a one-step procedure or the second step of a two-step procedure.

This application must produce a clean aircraft surface and the condition of the resultant fluid layer on the aircraft surface must allow use of Holdover Time Tables.

- Using forced air with injected SAE Type II or IV anti-icing fluid as the second step of a two-step procedure or as an application on a clean wing for frost protection.

The condition of the resultant fluid layer on the aircraft surface must allow use of Holdover Time Tables.

- Using forced air with injected SAE Type II or IV anti-icing fluid on a clean wing prior to the start of forecasted freezing precipitation to prevent ice or snow from bonding to surfaces.

The condition and thickness of the fluid layer are not critical in this application.

## Objectives

The objectives of this project were to examine the following:

- noise intensity generated by the forced air equipment;
- effect on visibility when removing snow and ice;
- capacity of the forced air deicing system to dislodge chunks of snow or ice and to fling them some distance and height;
- pressure exerted by the air stream on the skin of the aircraft;
- effect on aircraft skin temperature;
- elapsed time following deicing before refreezing occurred;
- residue in quiet areas; and
- viscosity of the Type IV fluid applied with the air stream.

Test objectives were satisfied by conducting a series of tests under controlled conditions at the National Research Council Canada Climatic Engineering Facility

(CEF) in Ottawa. A Vestergaard Elephant  $\mu$  (also referred to as Elephant  $M\mu$ ) deicing vehicle retrofitted with a Vestergaard forced air system was used for the tests. A JetStar test wing was positioned in the CEF and subjected to conditions of freezing rain and dry and wet snow. Contamination on the wing was removed in various tests by blown air, a blown air/fluid mix, and standard application of heated fluid.

## **Preliminary Trials at Chicago**

In November 1999 an independent set of tests coordinated by United Airlines and American Airlines was conducted at Chicago International Airport to examine some aspects of safety and performance. Forced air deicing systems from several manufacturers were examined in these tests. Because the Chicago tests were preliminary in nature, and did not examine the ability of the tested equipment to produce and maintain a clean aircraft surface under precipitation adequate for application of an anti-icing over spray, no firm conclusions on operational use of those tested systems can be made. Further tests on the forced air systems tested at Chicago, similar to those reported in the current study, would be required to draw such conclusions.

## **Results and Conclusions**

### *Noise Levels*

Measured noise levels were greater than the International Air Transport Association Airport Handling Manual standard of 85 dBA at 15 ft. from the vehicle perimeter, but could be controlled to acceptable levels through wearing of hearing protectors.

### *Effect on Visibility*

The loss of visibility related to vapour generation from heated fluid was less for the air/fluid combination than for the standard nozzle method of fluid application.

Snow blown by the forced air stream did not cause any significant loss of visibility either to the deicing operator in the bucket or to the vehicle driver.

### *Ice and Snow Projectiles*

Removal of the thin film of ice with the air/fluid combination resulted in small coin-sized pieces of ice being lifted from the wing and blown away to fall near the wing perimeter.

Snow was removed primarily by erosion, and the resulting separate snow crystals were blown away from the wing. Occasional clumps of snow were lifted and these fell near the wing perimeter.

The forced air deicing system as tested presented no significant hazardous condition for ice and snow projectiles.

### *Pressure on Wing Skin*

The forced air application and the air/fluid combination produced similar pressure on the wing surface, but less than the force exerted by the standard fluid nozzle.

The forces exerted on the aircraft surface by the forced air deicing system as tested were operationally acceptable.

### *Temperature on Wing Skin*

The temperature rise in aircraft surfaces subjected to the forced air deicing system as tested was less than with the standard method of deicing. While it does not pose a problem to the aircraft skin, it has a detrimental effect on the interval from deicing until refreezing occurs.

### *Elapsed Time until Refreezing*

#### i. Removal of Ice

The forced air application was unable to break the bond between the layer of ice and the wing surface, as the heat transfer from the air stream was insufficient to melt through the ice.

The air/fluid combination did melt through the ice and cleaned the wing in just over 7 minutes. The time to refreeze was just under 4 minutes.

The standard fluid application cleaned the wing in just over 3 minutes. Time to refreeze was 8 minutes.

#### ii. Removal of Dry Snow

With forced air deicing, refreezing occurred immediately. Skin temperature only rose from  $-18^{\circ}\text{C}$  to  $-16^{\circ}\text{C}$ .

Cleaning the wing with the air/fluid combination produced a clean wing but refreezing occurred at less than one minute after deicing. The interval until refreezing occurred was considerably less than the typical three-minute

interval documented in SAE ARP4737. The reduction in time until refreezing must be at least partially due to the reduced heat transfer to the wing, but the thickness of the fluid film may also be a factor and should be investigated.

iii. Removal of Wet Snow

The forced air application left a film of snow over the entire wing surface at the end of deicing. Small clumps of adhered snow were scattered across the wing surface. Time to refreeze was zero.

The air/fluid combination produced a clean wing but time to refreeze was less than one minute.

The use of forced air alone (with the equipment as tested) is not a feasible alternative for either the first step of a two-step deicing procedure or as a one-step procedure.

The air/fluid combination as tested is not a feasible alternative during snowfall and cold outside air temperature, for either the first-step of a two-step deicing procedure or as a one-step procedure.

The heat transfer to the wing surface was much greater with the standard method of deicing and is believed to be a major contributing factor to the longer times to refreeze with the standard method.

It is unknown whether the thickness of the fluid film resulting from the air/fluid method was similar to that of the standard spray. This should be examined in future tests.

*Residue in Quiet Areas*

i. Ice Removal

Fluid residues following the standard nozzle deicing method and the air/fluid combination were very similar.

ii. Dry Snow Removal

The quiet area check was conducted only for the test using forced air alone to clean the wing. No residue was seen.

iii. Wet Snow Removal

The wet snow was forced under the slat trailing edge by the pressure of the combined air/fluid stream. This produced flat snow platelets having a depth equal to the gap between the slat and wing.

*Shearing of Type IV Fluid*

The final viscosity of fluid injected into the air stream and applied at a 0.9 m (3 ft.) distance was reduced from the initial value and was below the manufacturers' specified level. At all other distances, the final viscosity was equal to or greater than the initial value.

Any further tests should attempt to determine the viscosity and condition of the fluid on the wing during the period when holdover times normally apply.

Recommendations:

1. Other forced air deicing systems in current operational use should be examined to determine whether they are an acceptable alternative for either the first step of a two-step deicing procedure or for the one-step procedure.
2. Test specifications should be developed for evaluating the safety of forced air systems and the operational acceptability in performing either step of a two-step operation or a complete one-step deicing operation.
3. The thickness and rate of dilution of the Type I fluid layer remaining on the wing following application with a fluid/air combination nozzle should be examined in conjunction with wing skin temperature decay profiles for each of the forced air deicing systems in current operational use.
4. The condition, thickness, and viscosity of Type IV fluid remaining on the wing during the period when holdover times normally apply (following application with a fluid/air combination nozzle) should be examined for each of the forced air deicing systems in current operational use.

## SOMMAIRE

À la demande du Centre de développement des transports de Transports Canada et de la Federal Aviation Administration des États-Unis, APS Aviation a lancé un programme de recherche visant à examiner les incidences sur la sécurité des systèmes de dégivrage à air forcé.

### Contexte

Les compagnies aériennes se montrent de plus en plus intéressées par le recours à l'air forcé pour chasser les contaminants gelés de la surface des avions. Cet intérêt coïncide d'ailleurs avec la mise au point, par plusieurs fabricants, de systèmes à air forcé montés sur les véhicules de dégivrage classiques. Il est prévu que certaines compagnies aériennes utiliseront le dégivrage à air forcé pendant l'hiver 2000-2001.

Aucune méthodologie pour l'utilisation d'air forcé en tant que partie intégrante des opérations de dégivrage n'a encore été mise au point, et les procédures d'utilisation normalisées sont toujours en cours de développement.

Certains systèmes de dégivrage à air forcé soufflent de l'air ou un mélange d'air et de liquide à haute pression, tandis que d'autres soufflent de grands volumes d'air à faible pression. Certaines buses éjectent l'air à une très grande vitesse. Il en résulte un jet d'air élançé, qui allonge la portée efficace du courant d'air. D'autres systèmes sont conçus de façon que la vitesse de l'air diminue radicalement à la sortie de la buse. Dans certains cas, le courant d'air est plus chaud que l'air ambiant, en raison de la chaleur de compression.

Comme l'utilisation des systèmes de dégivrage à air forcé est relativement nouvelle, les incidences sur la sécurité – soit les risques de blessures au personnel et de dommages à l'avion, et les dangers associés au décollage d'un avion qui ne serait pas bien nettoyé – suscitent des inquiétudes.

### Principes du dégivrage à air forcé

L'incorporation du dégivrage à air forcé à la panoplie des méthodes de dégivrage peut prendre plusieurs formes :

- Utilisation d'air forcé seul ou avec un liquide de type I injecté dans le courant d'air pour enlever le plus gros de la contamination, avant de dégivrer les surfaces avec un liquide chauffé.

Cette méthode peut diminuer le temps de dégivrage et la quantité de liquide à appliquer dans un deuxième temps; mais elle ne vise ni ne prétend à rendre les ailes suffisamment propres pour le décollage.

- Utilisation d'air forcé seul ou avec un liquide de type I injecté dans le courant d'air, en tant que première étape d'une procédure de dégivrage à deux étapes.

Cette méthode doit produire des surfaces exemptes de contamination et celles-ci doivent le rester jusqu'à la deuxième étape de la procédure, soit l'application d'un liquide antigivrage. Un intervalle minimal de trois minutes entre les deux applications est généralement accepté.

- Utilisation d'air forcé avec un liquide SAE de type I injecté dans le courant d'air en tant que procédure à une seule étape ou que deuxième étape d'une procédure à deux étapes.

Cette application doit produire des surfaces exemptes de contamination et l'état de la couche de liquide déposée sur la surface de l'avion doit permettre l'utilisation des tables de durée d'efficacité.

- Utilisation d'air forcé avec un liquide antigivrage SAE de type II ou de type IV injecté dans le courant d'air, en tant que deuxième étape d'une procédure à deux étapes ou en tant que procédure de protection antigivrage d'une aile propre.

L'état de la couche de liquide déposée sur la surface de l'avion doit permettre l'utilisation des tables de durée d'efficacité.

- Utilisation d'air forcé avec un liquide antigivrage SAE de type II ou de type IV injecté dans le courant d'air sur une aile propre avant le début d'une précipitation givrante annoncée, pour empêcher le givre ou la neige d'adhérer aux surfaces.

L'état et l'épaisseur de la couche de liquide ne sont pas critiques dans ce cas.

## Objectifs

Ce projet visait à étudier ce qui suit :

- le niveau de bruit généré par les équipements de soufflage d'air forcé;
- l'effet sur la visibilité de l'enlèvement de neige et de givre;
- la tendance du système de dégivrage à air forcé à projeter à une certaine distance et en hauteur les morceaux de neige ou de givre délogés des surfaces;
- la pression exercée par le courant d'air sur le revêtement de l'avion;
- l'effet du courant d'air sur la température du revêtement de l'avion;
- le temps écoulé entre la fin du dégivrage et l'apparition des premiers signes de givrage;
- les résidus de contamination dans les zones à inertie aérodynamique;
- la viscosité du liquide de type IV injecté dans le courant d'air forcé.

Une série d'essais a eu lieu dans des conditions contrôlées à l'Installation de génie climatique (IGC) du Conseil national de recherches du Canada à Ottawa. Un véhicule de dégivrage Vestergaard Elephant  $\mu$  (aussi appelé Elephant  $M\mu$ ) équipé d'un système à air forcé Vestergaard a servi aux essais. Une aile d'essai de JetStar a été emmenée dans l'IGC et soumise à des conditions de pluie verglaçante et de neige sèche et mouillée. Puis la contamination sur l'aile était enlevée par diverses méthodes : air soufflé, mélange d'air et de liquide soufflé, application classique de liquide chauffé.

## **Essais préliminaires de Chicago**

En novembre 1999, une série indépendante d'essais, coordonnée par United Airlines et American Airlines, a été menée à l'aéroport international de Chicago. Le but était d'examiner certains aspects de la sûreté et des performances des systèmes à air forcé de plusieurs fabricants. Comme les essais de Chicago étaient essentiellement préliminaires et comme on n'a pas examiné la capacité des systèmes de nettoyer une surface d'avion et de la garder propre dans des conditions de précipitations qui nécessitent l'application d'un liquide antigivrage après le dégivrage, il n'est pas possible de tirer des conclusions définitives concernant l'utilisation en service réel des systèmes mis à l'essai. Pour pouvoir tirer de telles conclusions, il faudrait soumettre les systèmes à air forcé étudiés à Chicago à des essais semblables à ceux réalisés au cours de la présente étude.

## **Résultats et conclusions**

### *Niveaux de bruit*

Les niveaux de bruit mesurés dépassaient la norme de 85 dBA établie par le *Airport Handling Manual* de l'Association du transport aérien international dans un rayon de 15 pi du véhicule, mais le port de protecteurs d'oreilles pourrait pallier la situation.

### *Effet sur la visibilité*

La diminution de la visibilité due à la vapeur produite par le liquide chauffé était moindre dans le cas de l'application de la combinaison air/liquide que lors de l'application de liquide par la méthode classique.

La neige chassée par le courant d'air forcé ne diminuait pas de façon importante la visibilité, ni pour l'opérateur dans sa nacelle, ni pour le conducteur du véhicule.

### *Projections de givre et de neige*

Lors de l'enlèvement de la mince couche de givre à l'aide de la combinaison air/liquide, de petits morceaux de givre de la grosseur d'une pièce de monnaie se soulevaient de la surface et tombaient en proche périphérie de l'aile.



C'est principalement l'érosion qui faisait la neige se détacher de la surface, et le courant d'air qui chassait ensuite les cristaux de neige. Les plaques de neige qui pouvaient encore adhérer étaient soulevées et tombaient en proche périphérie de l'aile.

Le système de dégivrage à air forcé tel que mis à l'essai n'a pas créé de danger important pour ce qui est des projections de neige et de givre.

#### *Pression sur le revêtement de l'aile*

Le soufflage d'air forcé et le soufflage de la combinaison d'air/liquide produisaient une pression équivalente sur la surface de l'aile, mais moindre que la pression exercée par la buse utilisée pour l'application de fluide par la méthode classique.

Les forces exercées sur la surface de l'avion par le système de dégivrage à air forcé mis à l'essai étaient acceptables d'un point de vue opérationnel.

#### *Température du revêtement de l'aile*

La hausse de la température des surfaces de l'avion nettoyées à l'aide du système de dégivrage à air forcé mis à l'essai était moindre que la hausse associée à la méthode de dégivrage classique. Cela n'est pas un inconvénient pour le revêtement de l'avion, mais l'intervalle entre le dégivrage et l'apparition des premiers signes de givrage se trouve raccourci.

#### *Temps écoulé entre la fin du dégivrage et l'apparition des premiers signes de givrage*

##### i. Enlèvement de givre

L'application d'air forcé ne pouvait pas détacher la couche de givre de la surface de l'aile, car la chaleur transférée par le courant d'air était insuffisante pour faire fondre le givre.

La combinaison air/liquide faisait fondre le givre et laissait l'aile propre en un peu plus de sept minutes. En un peu moins de quatre minutes, du givre réapparaissait.

Par la méthode classique d'application de liquide, il fallait un peu plus de trois minutes pour nettoyer l'aile et le givre réapparaissait après huit minutes.

##### ii. Enlèvement de neige sèche

Avec le dégivrage à air forcé, le givre réapparaissait immédiatement. La température du revêtement gagnait seulement deux degrés, passant de -18 °C à -16 °C.

La combinaison air/liquide laissait une aile propre, mais celle-ci se couvrait de givre en moins d'une minute après le dégivrage. Ainsi, le délai jusqu'à la réapparition de givre était beaucoup plus court que les trois minutes citées dans la pratique recommandée ARP4737 de la SAE. Cette faible durée de protection est vraisemblablement due, au moins en partie, à un transfert de chaleur moindre vers l'aile, mais l'épaisseur de la couche de liquide peut aussi avoir un rôle à jouer, ce qui devrait être tiré au clair.

iii. Enlèvement de neige mouillée

À la fin de l'application d'air forcé, il subsistait une mince couche de neige sur toute la surface de l'aile. Et un peu partout sur la surface de l'aile, de petites masses de neige adhéraient encore. Le délai jusqu'à la réapparition de givre était nul.

La combinaison air/liquide a produit une aile propre, mais le délai jusqu'à un nouveau givrage était inférieur à une minute.

L'utilisation d'air forcé seul (avec l'équipement mis à l'essai) n'est pas une solution de rechange réaliste, que ce soit en tant que première étape d'une procédure de dégivrage à deux étapes ou en tant que procédure à une seule étape.

L'injection de liquide de dégivrage dans le courant d'air forcé, telle que mise à l'essai, n'est pas une solution de rechange réaliste lorsqu'il neige et que la température extérieure est basse, que ce soit en tant que première étape d'une procédure de dégivrage à deux étapes ou en tant que procédure à une seule étape.

La chaleur transférée à la surface de l'aile est beaucoup plus importante lorsque la méthode classique de dégivrage est utilisée, et cela pourrait expliquer en grande partie pourquoi la méthode de dégivrage classique donne une durée de protection contre le givrage plus longue.

Il n'a pas été déterminé si l'épaisseur de la couche de liquide déposée par la méthode air/liquide était équivalente à celle de la couche déposée par la méthode classique. Cette question devrait être étudiée à l'occasion d'autres essais.

*Résidus dans les zones à inertie aérodynamique*

i. Enlèvement de givre

Les résidus de liquide après le dégivrage par la méthode classique de pulvérisation et par le soufflage d'un courant d'air injecté de liquide étaient très semblables.

ii. Enlèvement de neige sèche

La vérification des zones à inertie aérodynamique a été faite seulement après l'essai faisant appel au soufflage d'air forcé seul sur une aile propre. Aucun résidu n'a été observé.

iii. Enlèvement de neige mouillée

La pression du courant d'air injecté de liquide faisait pénétrer la neige mouillée sous le bord de fuite du bec de bord d'attaque. Il se formait ainsi des plaquettes de neige d'épaisseur égale à l'écart entre le bec de bord d'attaque et l'aile comme telle.

*Cisaillement du liquide de type IV*

La viscosité finale du liquide injecté dans le courant d'air et appliqué d'une distance 0,9 m (3 pi) était moindre que sa viscosité initiale et était inférieure à sa valeur nominale établie par le fabricant. À toutes les autres distances d'application, la viscosité finale était égale ou supérieure à la viscosité initiale.

Si d'autres essais étaient entrepris, il y aurait lieu de déterminer la viscosité et l'état du liquide déposé sur l'aile pendant la période au cours de laquelle celui-ci est présumé efficace selon les tables de durée d'efficacité.

**Recommandations**

1. Étudier les autres systèmes de dégivrage à air forcé actuellement utilisés en service réel afin de déterminer s'ils constituent une solution de rechange acceptable, soit en tant que première étape d'une procédure à deux étapes ou en tant que procédure à une seule étape.
2. Mettre au point des méthodes d'essai pour évaluer la sûreté des systèmes à air forcé et leur conformité à des normes opérationnelles, pour exécuter une ou l'autre des étapes d'une procédure à deux étapes ou pour exécuter seuls une opération de dégivrage à une étape.
3. Étudier l'épaisseur et le taux de dilution de la couche de liquide de type I qui demeure sur l'aile après une application avec la buse adaptée à la combinaison air/liquide, en regard des profils de diminution de la température du revêtement de l'aile, pour chaque système de dégivrage à air forcé présentement utilisé en service réel.
4. Étudier l'état, l'épaisseur et la viscosité du liquide de type IV qui demeure sur l'aile pendant la période au cours de laquelle celui-ci est présumé efficace selon les tables de durée d'efficacité (après une application avec une buse adaptée à la combinaison air/liquide), pour chaque système de dégivrage à air forcé présentement utilisé en service réel.

CONTENTS

Page

1. INTRODUCTION ..... 1

1.1 Background ..... 1

1.2 Forced Air Deicing Concepts ..... 2

1.3 Work Statement ..... 3

1.4 Objectives ..... 3

2. METHODOLOGY ..... 5

2.1 Test Site ..... 5

2.2 Description of Test Procedures ..... 5

2.2.1 Noise Levels Generated by the Forced Air Equipment ..... 5

2.2.2 Effect on Visibility when Removing Snow and Ice ..... 6

2.2.3 Ice and Snow Projectiles ..... 6

2.2.4 Air Stream Pressure on Wing Skin ..... 7

2.2.5 Temperature of Test Surface ..... 8

2.2.6 Elapsed Time until Refreezing ..... 8

2.2.7 Residue in Quiet Areas ..... 10

2.2.8 Shearing of Type IV Fluid ..... 10

2.3 Types of Precipitation ..... 10

2.4 Test Plan ..... 11

2.5 Data Forms ..... 11

2.6 Equipment ..... 22

2.7 Fluids ..... 25

2.8 Personnel and Participation ..... 25

3. DESCRIPTION AND PROCESSING OF DATA ..... 49

3.1 Overview of Tests ..... 49

3.2 Description of Data Collected and Analysis ..... 49

3.2.1 Noise Levels ..... 49

3.2.2 Visibility ..... 49

3.2.3 Ice and Snow Projectiles ..... 52

3.2.4 Pressure on Wing Skin ..... 52

3.2.5 Temperature of Wing Skin ..... 52

3.2.6 Elapsed Time until Refreezing ..... 55

3.2.7 Residue in Quiet Areas ..... 55

3.2.8 Shearing of Type IV Fluid ..... 55

4. ANALYSIS AND OBSERVATIONS ..... 63

4.1 Noise Levels ..... 63

4.2 Effect on Visibility ..... 63

4.3 Ice and Snow Projectiles ..... 64

4.4 Pressure on Wing Skin ..... 64

4.5 Temperature on Wing Skin ..... 68

4.6 Elapsed Time until Refreezing ..... 68

4.6.1 Removal of Ice ..... 68

4.6.2 Removal of Dry Snow ..... 71

4.6.3 Removal of Wet Snow ..... 79

4.7 Residue in Quiet Areas ..... 81

4.7.1 Ice Removal ..... 81

4.7.2 Dry Snow Removal ..... 83

4.7.3 Wet Snow Removal ..... 83

**TABLE OF CONTENTS**

---

4.8 Shearing of Type IV Fluids ..... 83

5. CONCLUSIONS..... 91

5.1 Noise Levels ..... 91

5.2 Effect on Visibility ..... 91

5.3 Ice and Snow Projectiles..... 91

5.4 Pressure on Wing Skin ..... 92

5.5 Temperature on Wing Skin ..... 92

5.6 Elapsed Time until Refreezing..... 93

    5.6.1 Removal of Ice..... 93

    5.6.2 Removal of Dry Snow..... 93

    5.6.3 Removal of Wet Snow ..... 94

5.7 Residue in Quiet Areas ..... 94

    5.7.1 Ice Removal ..... 94

    5.7.2 Dry Snow Removal..... 94

    5.7.3 Wet Snow Removal ..... 95

5.8 Shearing of Type IV Fluid ..... 95

5.9 Appropriate Use of Forced Air in Deicing Operations ..... 95

6. RECOMMENDATIONS ..... 99

**APPENDICES**

- A Terms of Reference – Project Description
- B Experimental Program – Forced Air Deicing Safety Trials
- C Forced Air Deicing Trials April 2000 – List of Visiting Observers
- D Test Data from Trials Conducted at Chicago Airport – November 1999

**LIST OF FIGURES**

	Page
2.1	Thermistor Probes Mounting Location on Test Wing ..... 9
2.2	General Form (Every Test) ..... 14
2.3	Icing Form for JetStar Wing..... 15
2.4	Quiet Area – Residual Water Accumulation Test ..... 16
2.5	Projectile Distribution ..... 17
2.6	Projectile Distribution Grid ..... 18
2.7	Precipitation Rate/Snow Density Measurement at CEF in Ottawa ..... 19
2.8	Pressure Test ..... 20
2.9	Measure of Noise Level ..... 21
2.10	Air Velocity of Vestergaard Forced Air System..... 23
2.11	Test Wing and Deicing Vehicle in Test Facility..... 24
3.1	Noise Measurements (dBA)..... 51
3.2	Force on a 25 in <sup>2</sup> Disc – Forced Air without Fluid Injection ..... 53
3.3	Wing Skin Temperature vs. Nozzle Distance..... 54
3.4	Icing Form for JetStar Wing – Completed ..... 56
3.5	General Form (Every Test) – Completed ..... 57
3.6	Wing Skin Temperature Profiles, ID #2 – Ice 0.25 cm (0.1”) Thick, Std Type I Deicing ..... 59
3.7	Quiet Area – Residual Water Accumulation Test (Completed)..... 60
3.8	Fluid Viscosity vs. Nozzle Type and Distance – Ethylene Glycol-Based Type IV Fluid ..... 61
4.1	Force on a 25 in <sup>2</sup> Disc – Forced Air without Fluid Injection ..... 65
4.2	Force on a 25 in <sup>2</sup> Disc – Forced Air with Fluid Injection..... 66
4.3	Force on a 25 in <sup>2</sup> Disc – Fluid Injection, No Air ..... 67
4.4	Force on a 25 in <sup>2</sup> Disc – Std Type I Deicing, Akron Nozzle..... 69
4.5	Wing Skin Temperature Profiles, ID #2 – Ice 0.25 cm (0.1”) Thick, Std Type I Deicing ..... 72
4.6	Wing Skin Temperature Profiles, ID #3 – Ice 0.25 cm (0.1”) Thick, Air/Injected Type I Deicing..... 73
4.7	Wing Skin Temperature Profiles, ID #6 – Dry Snow 6.25 cm (2.5”) Thick, Air Deicing, OAT -18°C ..... 76
4.8	Wing Skin Temperature Profiles, ID #4 – Dry Snow 6.25 cm (2.5”) Thick, Air/Injected Type I Deicing, OAT -18°C ..... 77
4.9	Wing Skin Temperature Profiles, ID #5 – Dry Snow 6.25 cm (2.5”) Thick, Std Type I Deicing, OAT -17°C ..... 78
4.10	Wing Skin Temperature Profiles, ID #8 – Wet Snow 6.25 cm (2.5”) Thick, Air/Injected Type I Deicing, OAT -14°C ..... 82
4.11	Wing/Flight Control Surface Gaps..... 84

**LIST OF TABLES**

	Page
2.1	Forced Air Deicing Trials – Test Plan ..... 12
2.2	Forced Air Deicing Trials – Test Schedule..... 13
3.1	Forced Air Deicing Trials – Test History..... 50
3.2	Removal of Ice 0.25 cm (0.1”) Thick, Ambient Temp. = -10°C, Freezing Rain ..... 58
4.1	Removal of Ice 0.25 cm (0.1”) Thick, Ambient Temp. = -10°C, Freezing Rain @ ~ 15 g/dm <sup>2</sup> /h..... 70
4.2	Removal of Dry Snow 6.4 cm (2.5”) Thick, Ambient Temp. = -17°C ..... 74

**LIST OF FIGURES, TABLES, AND PHOTOS**

---

4.3 Removal of Wet Snow 6.4 cm (2.5") Thick, Ambient Temp. = -15°C ..... 80  
5.1 Use of Forced Air to Remove Bulk of Contamination Prior to Deicing with Heated Fluid ..... 96  
5.2 Use of Forced Air for the first Step of a Two-Step Procedure, Followed by Application of Cold Anti-Icing Fluid..... 96  
5.3 Use of Forced Air as a One-Step Procedure ..... 97  
5.4 Use of Forced Air as a Protective Application Prior to Start of Precipitation..... 97

**LIST OF PHOTOS**

**Page**

2.1 Digital Sound Meter ..... 27  
2.2 Sound Meter Test ..... 27  
2.3 Noise Sensor Enclosed in Hearing Protector ..... 29  
2.4 Video and Laptop Monitors ..... 29  
2.5 Reference Grids on Wall and Floor ..... 31  
2.6 Device to Measure Force of Air Stream ..... 31  
2.7 Measuring Air Stream Force at Close Range ..... 33  
2.8 Measuring Air Stream Force at Longer Range ..... 33  
2.9 Adjusting Distance and Angle of Forced Air Stream ..... 35  
2.10 Measuring Surface Temperature at Close Range ..... 35  
2.11 Measuring Surface Temperature at Longer Range ..... 37  
2.12 Monitoring for Refreezing ..... 37  
2.13 Thermistor Probe on Wing ..... 39  
2.14 Leading Edge Slat Lowered to Examine Residue ..... 39  
2.15 Examining Surfaces Exposed by Lowering Leading Edge Slat..... 41  
2.16 Brookfield Digital Viscometer Model DV-I+ and Temperature Bath..... 41  
2.17 Vestergaard Forced Air Deicing System ..... 43  
2.18 Forced Air System Installed on Bucket ..... 43  
2.19 Centrifugal Blower ..... 45  
2.20 Fluid Injection Nozzle ..... 45  
2.21 Wing Protected with Tarpaulin..... 47  
2.22 Digital Clock ..... 47  
4.1 Ice Reforming after Air/Injected Fluid Deicing ..... 85  
4.2 Wing Condition Following Air Deicing of Dry Snow ..... 85  
4.3 Wing Condition Following Air Deicing of Wet Snow ..... 87  
4.4 Wing Condition Following Air/Injected Fluid Deicing of Wet Snow ..... 87  
4.5 Slush Residue on Exposed Leading Edge Following Air/Injected Fluid Deicing of Wet Snow ..... 89  
4.6 Slush Residue in Leading Edge Slat Cavity Following Air/Injected Fluid Deicing of Wet Snow ..... 89

## **GLOSSARY**

AHM	Airport Handling Manual
APS	APS Aviation Inc.
CEF	Climatic Engineering Facility
FAA	Federal Aviation Administration
HOT	Holdover Time
IATA	International Air Transport Association
LE	Leading Edge
NRC Canada	National Research Council Canada
OAT	Outside Air Temperature
SAE	Society of Automotive Engineers, Inc.
TDC	Transportation Development Centre
UCAR	Union Carbide Corporation



*This page intentionally left blank.*

## 1. INTRODUCTION

At the request of the Transportation Development Centre (TDC) of Transport Canada and the Federal Aviation Administration (FAA), APS Aviation Inc. (APS) undertook a research program to examine safety implications of forced air deicing systems.

### 1.1 Background

Airlines have shown increased interest in the use of forced air deicing to blow frozen contaminants off an aircraft surface, corresponding to the development by several manufacturers of forced air systems mounted on conventional deicing vehicles. It is expected that a number of airlines will employ forced air deicing systems during the 2000-01 winter season.

The methodology of using forced air as an integral part of the deicing operation has not yet evolved, and standard operating procedures are still being developed.

APS uses the term forced air to describe the method of de/anti-icing involving the use of blown air, an air/fluid combination or just fluid on aircraft wings. For example, some forced air deicing systems use high-pressure air or an air/fluid mix, while others deliver large air volumes at low pressure. Different nozzle arrangements are used on different systems. Some of these deliver air at a very high speed at the nozzle, and very refined nozzles are designed to maintain a columnar air stream over an extended distance, thereby extending the effective reach of the high-speed air stream. Other designs demonstrate a very rapid decrease in the speed of the air stream after it exits the nozzle.

The use of forced air systems is a relatively new process, and safety implications are a primary concern. These include the potential for injury to personnel, the potential for damage to aircraft, and the ability to provide a clean aircraft for takeoff.

In November 1999 an independent set of tests coordinated by United Airlines and American Airlines was conducted at Chicago International Airport to examine some aspects of safety and performance. Forced air deicing systems from several manufacturers were examined in these tests. The results of the Chicago tests are included in Appendix D. Because the Chicago tests were preliminary in nature and did not examine the ability of the tested equipment to produce and maintain a clean aircraft surface under precipitation adequate for application of an anti-icing over spray, no firm conclusions on operational use of those tested systems can be made.

Further tests on the forced air systems tested at Chicago, similar to those reported in the current study, would be required to draw such conclusions.

## 1.2 Forced Air Deicing Concepts

Incorporation of forced air deicing into the deicing process can conceivably take any of several forms:

- a) Using forced air alone or with injected Type I fluid to remove most of the contamination from aircraft surfaces prior to deicing the aircraft and according to the standard procedure using heated fluid.

This approach provides a means of reducing subsequent deicing times and fluid quantities. It neither attempts nor claims to provide a clean wing for takeoff.

- b) Using forced air deicing as the first step of a two-step procedure.

This approach can use forced air alone or with injected Type I fluid and must satisfy two prerequisites:

- A clean aircraft surface must be produced.
- The cleaned aircraft critical surfaces must remain uncontaminated long enough for application of the second step anti-icing fluid. The minimum interval is generally accepted to be 3 minutes.

- c) Using forced air deicing as a one-step procedure or the second step of a two-step procedure.

This approach, which uses forced air with injected SAE Type I fluid, must satisfy two prerequisites:

- A clean aircraft surface must be produced for the one-step procedure.
- The thickness of the resultant fluid layer and the condition of the fluid on aircraft surfaces must be such that Holdover Time Tables can be used.

- d) Using forced air to assist in the application of SAE Type II or IV anti-icing fluid.

This approach could be used as the second step of a two-step procedure or as an application on a clean wing for frost protection. The fluid can be delivered in or on the air stream. This approach must satisfy the following prerequisite:

- The thickness and condition of the resultant fluid layer on aircraft surfaces must be such that Holdover Time Tables can be used.
- e) Using forced air to assist in the application of anti-icing fluid on a clean wing prior to the start of forecasted freezing precipitation.

The intent of this approach is to prevent ice or snow from bonding to surfaces and thereby ease the removal of contamination during later deicing. As holdover times do not apply in this case, and as the fluid is subsequently removed during the deicing operation, the condition and thickness of the fluid layer are inconsequential.

### 1.3 Work Statement

Appendix A presents an excerpt from the project description of the work statement for the APS 1999-2000 winter research program.

### 1.4 Objectives

The objectives of this project were to examine the following:

- noise intensity generated by the forced air equipment;
- effect on visibility when removing snow and ice;
- capacity of the forced air deicing system to dislodge chunks of snow or ice and to fling them some distance and height;
- pressure exerted by the air stream on the skin of the aircraft;
- temperature of the aircraft skin;
- elapsed time following deicing before refreezing occurred;
- residue in quiet areas; and
- viscosity of the Type IV fluid delivered to the aircraft surface within the air stream.

The original project description included the performance of a battery of tests on several brands of forced air deicing systems, with an expected test period of twelve days. Because of lack of funding, the scope was reduced to testing one system over a period of four days.

## 1. INTRODUCTION

---

These objectives were satisfied by conducting a series of tests under controlled conditions at the National Research Council Canada (NRC Canada) Climatic Engineering Facility (CEF) in Ottawa. A Vestergaard Elephant  $\mu$  deicing vehicle retrofitted with a Vestergaard forced air system was used for the tests. A JetStar test wing was positioned in the CEF and subjected to conditions of freezing rain and dry and wet snow. Contamination on the wing was removed in various tests by blown air, a blown air/fluid mix, and standard application of heated fluid.

## 2. METHODOLOGY

This section describes the test parameters and experimental procedures as well as the test equipment and personnel requirements used in these tests.

### 2.1 Test Site

After the forced air deicing system was installed on the deicing vehicle and while the vehicle was still at Dorval Airport, a trial run was conducted using some of the test procedures and equipment in conjunction with the forced air deicing system to identify and implement any needed refinements.

The formal tests were conducted at the NRC Canada CEF located near Ottawa International Airport. This facility was large enough to allow the deicing vehicle equipped with the forced air deicing system to be used to clean the JetStar test wing. The wing was positioned to enable it to be subjected to freezing rain and snow precipitation. The deicing vehicle was removed from the chamber after each trial was complete to allow the fluid heater to be operated continually while the truck was outdoors and to minimize heat and exhaust fumes inside the facility.

### 2.2 Description of Test Procedures

The test procedure is described in Appendix B. Tests were scheduled over a four-day period at the NRC Canada CEF. Set-up and takedown activities took place the first morning and the last afternoon.

#### 2.2.1 Noise Levels Generated by the Forced Air Equipment

A digital sound meter (Photo 2.1) was used to measure noise intensity. Intensity was measured on the "A" scale to conform to known regulations for acceptable levels of noise in the workplace. The "A" scale replicates sound intensity as perceived by human hearing by attenuating certain sound frequencies. The meter in the photo is taped to a tripod set at 1.5 m (5 ft.) above the ramp.

Noise tests were conducted outdoors with the deicing vehicle positioned at two locations: away from any buildings or structures that could affect the noise levels measured, and adjacent to a building wall.

Noise intensity was measured inside the vehicle cab, in the operator's bucket, and at several locations around the vehicle. The positioning of

the noise sensor when measuring around the vehicle was based on the International Air Transport Association (IATA) standard for measuring noise levels generated from ramp vehicles (IATA Airport Handling Manual: Standard AHM 910) a distance of 4.6 m (15 ft.) from the perimeter of the vehicle and at 1.5 m (5 ft.) above the ground.

Photo 2.2 shows the digital sound meter in use. The operator's bucket with attached air nozzle was raised to a typical operating height of 3 m (10 ft.) for these trials.

Noise levels were also measured with the noise sensor protected within a set of hearing protectors to evaluate noise levels for protected hearing. Photo 2.3 shows this test.

### 2.2.2 Effect on Visibility when Removing Snow and Ice

The effect on visibility was documented by observation and by videotaping with a field of view across the test wing surface against a background of reflective grids and markers.

A video camera was mounted on the deicing bucket in such a manner as to film the wing area being deiced with the air stream and to capture any loss of visibility experienced by the deicing operator.

A second video camera was located in the cab of the deicing vehicle to record any loss of visibility by the deicing vehicle driver.

Two video cameras were mounted on tripods positioned against opposite walls of the test chamber to provide views from different angles depicting the effect on visibility and of the projectile nature of loosened contamination. TV monitors for these cameras were set up outside the cold chamber (Photo 2.4) for viewing by visiting observers.

Vertical standards marked with strips of red and white retro-reflective tape were positioned about the perimeter of the wing.

A grid composed of retro-reflective tape applied in one-metre squares was marked on the chamber door on the far side of the wing. This grid can be seen in Photo 2.4.

### 2.2.3 Ice and Snow Projectiles

The extent to which loosened contamination was lifted and thrown by the forced air stream (projectiles) was documented by observation and

by videotaping, with a field of view across the test wing surface, against a background of reflective grids and markers, as described in Section 2.2.2.

Another grid was placed on the test chamber floor to document distance that projectiles were thrown. This grid consisted of a tarpaulin marked with one-meter squares and positioned under the wing, extending beyond the trailing edge. Photo 2.5 shows the floor and wall grids as well as the vertical standards positioned at the wing edge.

The final distribution of chunks of ice and snow was to be documented on videotape. Typical size and larger pieces were to be measured and weighed, and their final location noted using the grid data form.

During the deicing trials, the loosened contamination showed very little tendency to be thrown about, and any chunks of snow or ice that were lifted generally fell to the floor at the wing perimeter. To evaluate more extreme conditions, two special tests using pieces of ice placed on the wing surface were conducted.

For these tests, ice sheets 0.6 cm (0.25 in.) and 1.3 cm (0.5 in.) thick were formed in two large flat pans. The ice from each pan was broken up into randomly sized pieces that were weighed and then placed on the wing surface. The air blower was then directed toward the ice pieces and the resultant projectile effect was documented.

### 2.2.4 Air Stream Pressure on Wing Skin

Air stream pressure was measured with a device developed by APS for this test. This device was composed of a load cell fixed underneath a rigid platform (Photo 2.6). The platform had a circular opening with an area of 25 in<sup>2</sup>. A free-floating disc within the aperture sat directly on the load cell. The force of the air stream directed at the disc (Photos 2.7 and 2.8) was transmitted to the load cell. The load cell provided a real-time display and a digitized data file of the sensed force.

All deicing modes possible from the forced air device were measured, including forced air alone, forced air with fluid injected, and the injected fluid without air. A reference application of fluid was sprayed from a Type I Akron nozzle.



The angle of incidence of the applied forced air and fluid streams, and the distance from nozzle to load cell were varied (Photo 2.9) as follows:

- The angle of incidence was set to 30, 45, 60, and 90 degrees to the test surface.
- The air nozzle was tested at distances typical for an air nozzle: 0.3, 0.6, and 0.9 m (1, 2, and 3 ft.) from the surface.
- The Type I Akron nozzle was tested at typical distances for a fluid nozzle: 0.9, 1.8, and 2.7 m (3, 6, and 9 ft.) from the surface.

### 2.2.5 Temperature of Test Surface

The temperature of the test surface, as influenced by the application of forced air alone or with injected fluid, was measured. Measurements were taken using the standard aluminum test plate used for fluid holdover trials. Two thermocouples were imbedded in the plate surface and then linked to a display and data logger. The air or air/fluid applications were directed at the test surface (Photos 2.10 and 2.11) until a stable temperature was reached.

These tests were conducted with the nozzle at various distances (0.3 to 3 m (1 to 10 ft.) from the test surface. The angle of incidence was normal to the plate surface.

### 2.2.6 Elapsed Time until Refreezing

Following the deicing of the wing, the artificial precipitation was continued to enable assessment of the interval until refreezing occurred. This interval was documented by observers who monitored the wing following deicing and recorded the time of refreezing, and by tracking the temperature profile of the wing skin. Photo 2.12 shows an observer monitoring the wing surface for refreezing.

An array of thermistor probes was mounted on the wing surface to measure and log the temperature profile of the wing skin during and after the deicing application. The locations of the probes on the wing surface are shown in Figure 2.1. Photo 2.13 shows one of the installed probes on the wing. A laptop PC linked to the logger provided a real-time display of wing skin temperatures (Photo 2.4).

FIGURE 2.1  
THERMISTOR PROBES MOUNTING LOCATION ON TEST WING  
FORCED AIR DEICING TRIALS

---

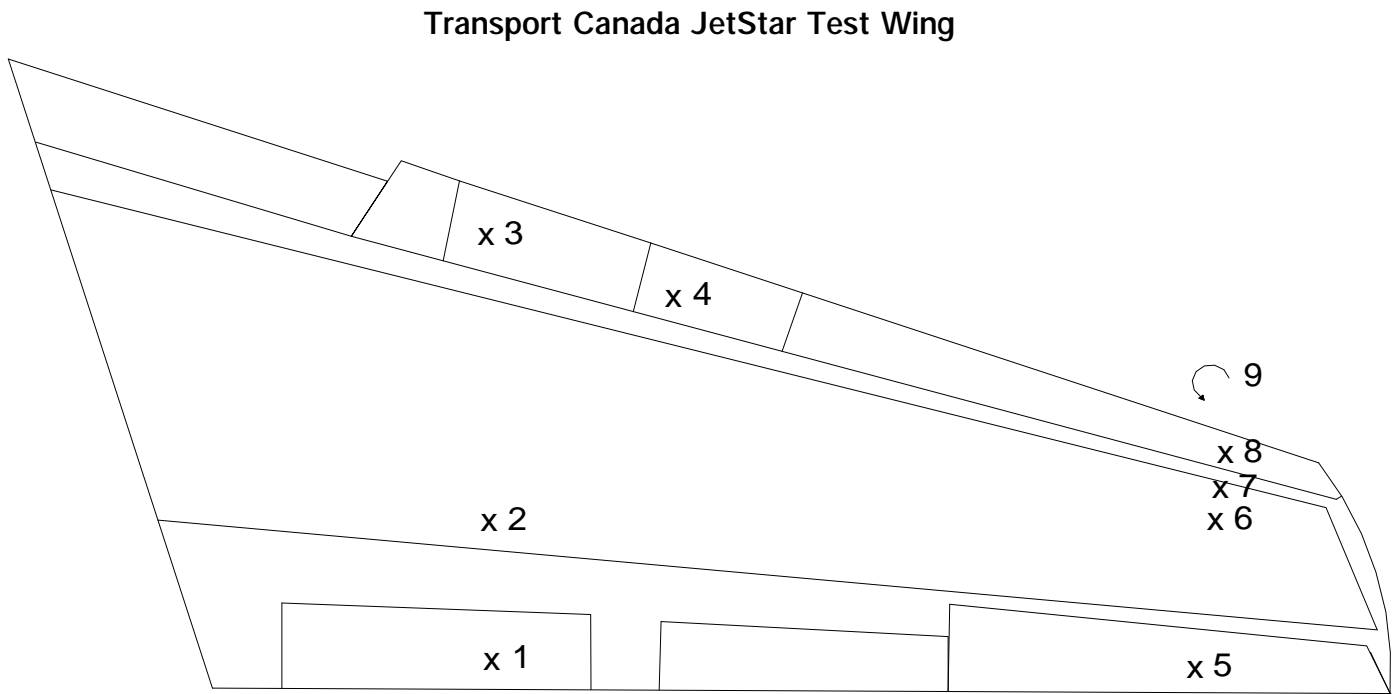

1. Mid-way forward, 1/3 distance from inner end
2. 15 cm (6") forward from edge of main wing, in chord with # 1
3. Mid-way on LE, in chord with # 1
4. Mid-way chordwise and laterally on surface
5. Mid-way chordwise, 1/3 distance from outer end
6. 30 cm (12") back from edge of main wing, in chord with # 5
7. 15 cm (6") back from edge of main wing, in chord with # 5
8. Slat upper surface/outer span, 1/2 on LE, in chord with # 5
9. Slat lower surface/outer span, 1/2 on LE, in chord with # 5

### 2.2.7 Residue in Quiet Areas

Following wing deicing, the flap, leading edge slat, and aileron flight control surfaces were lowered so that the wing recesses could be examined for evidence of any remaining fluid or solid contaminant (Photos 2.14 and 2.15).

Brix values were recorded for fluid residues. In some cases, the quantity of fluid in the recess was measured. This was done by absorbing the fluid into pre-weighed wiping cloths that were then re-weighed to calculate the fluid amount absorbed.

### 2.2.8 Shearing of Type IV Fluid

Tests were conducted to evaluate any shearing effect on Type IV fluid injected into the air stream. For these tests, the air/fluid stream was directed onto the same test plate surface used for temperature evaluation. Samples of the applied fluid were collected and labeled for later analysis of viscosity.

Variations on Type IV fluid applications included:

- Forced air with injected fluid;
- Fluid from the injector without forced air;
- Fluid from a Type IV Napiro nozzle;
- Fluid from a wand designed for AéroMag 2000 for light applications of Type IV fluid; and
- Fluid from the truck tanks.

Distances from nozzle to surface were varied at 0.9, 1.8, and 2.7 m (3, 6, and 9 ft.). The angle of incidence was fixed at 45° to the horizontal.

Viscosity of the various samples was measured by use of a Brookfield Viscometer (Photo 2.16). Fluid samples of 10 mL were centrifuged to remove air bubbles and cooled to 0°C. A number 31 spindle was used at 0.3 rpm for 10 minutes.

## 2.3 Types of Precipitation

For these trials, contamination was produced on the test wing surface by artificial freezing rain and by snow (both dry and wet). Rates of precipitation were measured following the standard procedure used in fluid holdover time trials. Pre-weighed rate pans were positioned at defined locations around the

wing perimeter, and the accumulated precipitation was weighed at fixed intervals.

During test set-up it was observed that the pattern of precipitation did not extend over the entire wing. The wing was repositioned to ensure good coverage over the wing area extending from the wing tip to about 2 m from the wing root.

## 2.4 Test Plan

Table 2.1 presents a matrix of the various tests. Table 2.2 presents a test schedule showing the planned distribution of tests over the four-day period.

## 2.5 Data Forms

The data forms are presented in the following figures:

Figure 2.2	General Form (Every Test)
Figure 2.3	Icing Form for JetStar Wing
Figure 2.4	Quiet Area – Residual Water Accumulation Test
Figure 2.5	Projectile Distribution
Figure 2.6	Project Distribution Grid
Figure 2.7	Precipitation Rate/Snow Density Measurement
Figure 2.8	Pressure Test
Figure 2.9	Measure of Noise Level

TABLE 2.1  
**FORCED AIR DEICING TRIALS – TEST PLAN**  
**NRC CANADA, OTTAWA, APRIL 17 - 20, 2000**

RUN	OAT (°C)	CONTAMINATION CONDITION	ACCUMULATION THICKNESS	DEICING MODE	PURPOSE OF TEST
1	-10	ZR (25 g/dm <sup>2</sup> /h)	0.25 cm (0.1")	Standard Type I fluid spray	Examine ice projectiles, elapsed time before refreezing, visibility, and residue in quiet areas
2	-10	ZR (25 g/dm <sup>2</sup> /h)	0.25 cm (0.1")	Air	
3	-10	ZR (25 g/dm <sup>2</sup> /h)	0.25 cm (0.1")	Air/injected Type I fluid	
4	-10	ZR (25 g/dm <sup>2</sup> /h)	0.5 cm (0.2")	Air/injected Type I fluid	
5	-10	Dry snow	4 cm (1.6")	Air	
6	-10	Wet snow	4 cm (1.6")	Air/injected Type I fluid	
7	-10	Wet snow	5 cm (1.6")	Air	
8	-10	Dry snow	8 cm (3.2")	Air	
9	-10	N/A	N/A	Standard Type I fluid spray	Pressure on wing skin
10	-10	N/A	N/A	Air	
11	-10	N/A	N/A	Air/injected Type I fluid	
12	-10	Dry	N/A	Air/injected Type IV fluid	Shearing of Type IV fluid
13	-10	Dry	N/A	Standard Type IV fluid spray	
14	N/A	N/A	N/A	Air	Measure noise levels

TABLE 2  
**FORCED AIR DEICING TRIALS – TEST SCHEDULE**  
**NRC OTTAWA APRIL 17 - 20, 2000**

	<b>Monday April 17, 2000</b>	<b>Tuesday April 18, 2000</b>	<b>Wednesday April 19, 2000</b>	<b>Thursday April 20, 2000</b>
8:00	Setup	Make dry snow 8cm (3.2") Noise test 14	Make dry snow 4cm (1.6") Shear test 12	Make wet snow 4cm (1.6")
8:30				
9:00				
9:30				
10:00				
10:30	Build up ice 2.5mm (0.1")	Snow Test 8	Snow Test 5	Snow Test 7
11:00				
11:30	Ice Test 1	Build up ice 2.5mm (0.1")	Make wet snow 4cm (1.6") Shear test 13	Tear down
12:00				
12:30				
13:00	Build up ice 0.5 cm (0.2") Pressure tests 9 to 11	Build up ice 2.5mm (0.1")	Snow Test 6	
13:30				
14:00				
14:30				
15:00				
15:30	Ice Test 4	Ice Test 3		
16:00				
16:30	Close	Close	Close	
17:00				

Note 1: Schedule for Pressure tests and Noise tests may be changed to conduct these during periods of snow or ice build up, if possible.

Note 2: all tests in lab performed at -10°C

FIGURE 2.2  
**GENERAL FORM (EVERY TEST)**  
**FORCED AIR DEICING TRIALS**

Date: \_\_\_\_\_

Aircraft Type: **JetStar Wing**

Run #: \_\_\_\_\_

DRAW DIRECTION OF TRUCK WRT WING:

Type of Application     AIR  
                                    AIR/INJECTED FLUID  
                                    FLUID

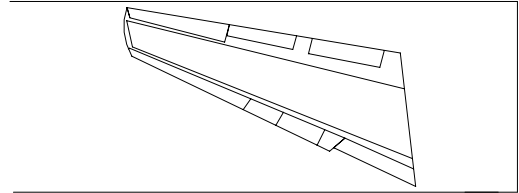

Truck #: \_\_\_\_\_

Distance from Nozzle to Wing \_\_\_\_\_ m

Type I Fluid Nozzle Type: \_\_\_\_\_

Angle of Jet Blast  
 relative to Horizontal: \_\_\_\_\_

<i><b>PRECIPITATION</b></i>			
Actual Start Time:	_____ hh:mm:ss	Actual End Time:	_____ hh:mm:ss
Start Temperature	_____ °C	End Temperature:	_____ °C

<i><b>DEICING APPLICATION</b></i>			
Actual Start Time:	_____ hh:mm:ss	Actual End Time:	_____ hh:mm:ss
Amount of Fluid Sprayed:	_____ L / gal	Type of Fluid:	_____
Fluid Temperature:	Tank: _____ °C	Nozzle:	_____ °C
Fluid Brix:	_____		

COMMENTS: \_\_\_\_\_  
 \_\_\_\_\_  
 \_\_\_\_\_  
 \_\_\_\_\_  
 \_\_\_\_\_

MEASUREMENTS BY: \_\_\_\_\_  
 HANDWRITTEN BY: \_\_\_\_\_

FIGURE 2.3  
**ICING FORM FOR JETSTAR WING**  
**FORCED AIR DEICING TRIALS**

DATE: \_\_\_\_\_

RUN #: \_\_\_\_\_

**RECORDING INFORMATION:**

- At time of 1st freezing: - Note location and time on wing form. Advise other team members.
- 5 minutes after 1st freezing: - Record patterns of ice on the wing form.  
- Measure and record ice thickness and roughness.
- Wing Cavity Inspection: - Record appearance of any ice formation. Use additional forms as needed.

Initial Snow/Ice Depth	
Location	Depth

Refrozen Snow/Ice Patches	
Location	Thickness

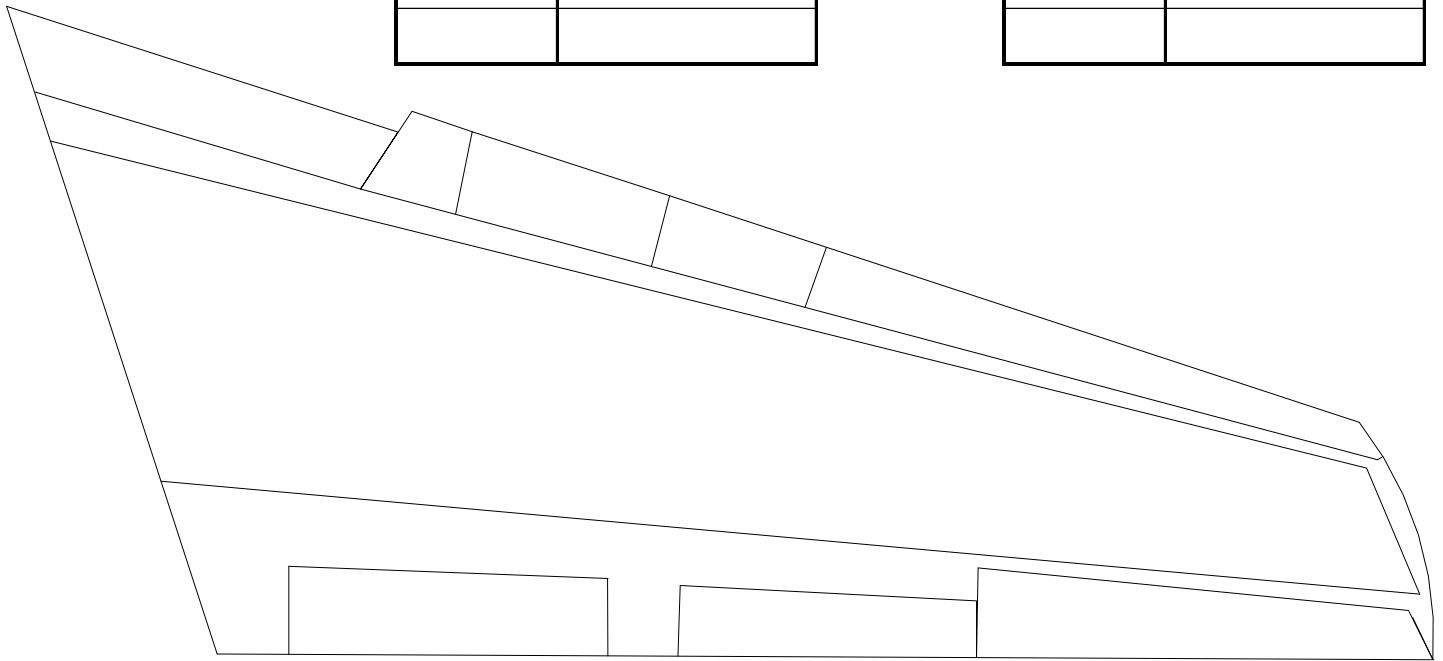

COMMENTS: \_\_\_\_\_

ICING RECORD BY: \_\_\_\_\_

\_\_\_\_\_

HANDWRITTEN BY: \_\_\_\_\_

\_\_\_\_\_



FIGURE 2.4  
**QUIET AREA – RESIDUAL WATER ACCUMULATION TEST**  
 FORCED AIR DEICING TRIALS

Date: \_\_\_\_\_

Type of Precipitation: \_\_\_\_\_

Run #: \_\_\_\_\_

OAT: \_\_\_\_\_ °C

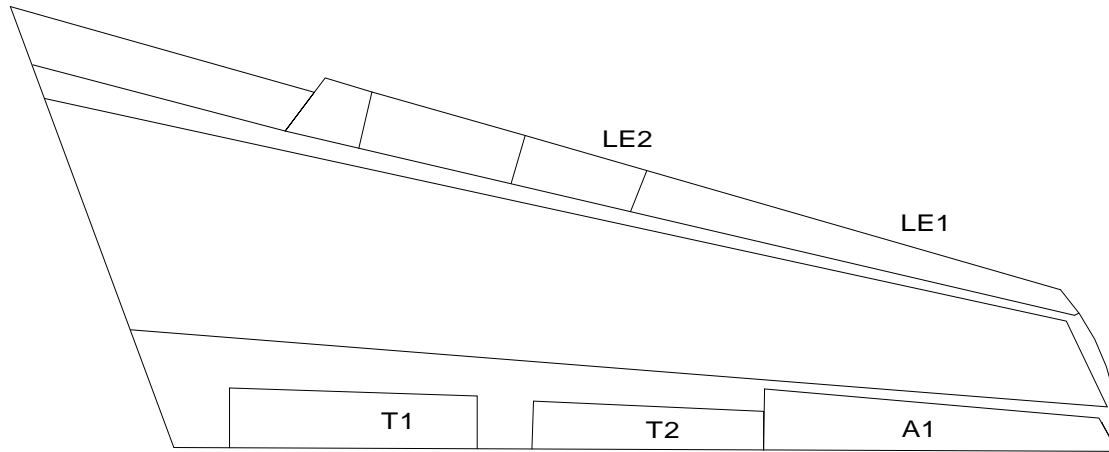

Tester	Location	Bucket Weight Before	Bucket Weight After	BRIX
	LE1 Top			
	LE1 Bottom			
	LE2 Top			
	LE3 Bottom			
	T1			
	T1			
	A1			

Comments: \_\_\_\_\_

Recorded by: \_\_\_\_\_

FIGURE 2.5  
**PROJECTILE DISTRIBUTION**  
**FORCED AIR DEICING TRIALS**

Run #: \_\_\_\_\_

Date: \_\_\_\_\_

Time: \_\_\_\_\_

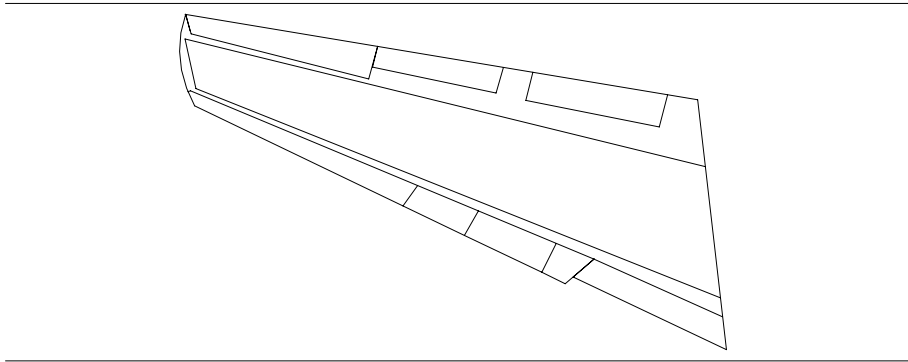

PROJECTILE SAMPLES

(Note Sample # in grid where located.)

#	Dimensions (cm x cm)	Weight (g)

FIGURE 2.6  
**PROJECTILE DISTRIBUTION GRID**  
FORCED AIR DEICING TRIALS

Run #: \_\_\_\_\_

Date: \_\_\_\_\_

Time: \_\_\_\_\_

- Note:** 1) Sketch outline of wing on grid, and  
2) Record and label sample locations.

FIGURE 2.7  
**PRECIPITATION RATE/SNOW DENSITY MEASUREMENT AT CEF IN OTTAWA**  
**FORCED AIR DEICING TRIALS**

Date: \_\_\_\_\_ Needles used: \_\_\_\_\_  
 Start Time: \_\_\_\_\_ Flow Rate of Water: \_\_\_\_\_  
 Run # : \_\_\_\_\_ Line Air Pressure: \_\_\_\_\_  
 Precip Type: Snow / ZR- Line Air Temperature: \_\_\_\_\_  
 Line Water Pressure: \_\_\_\_\_  
 Line Water Temperature: \_\_\_\_\_

**Pan Location:**

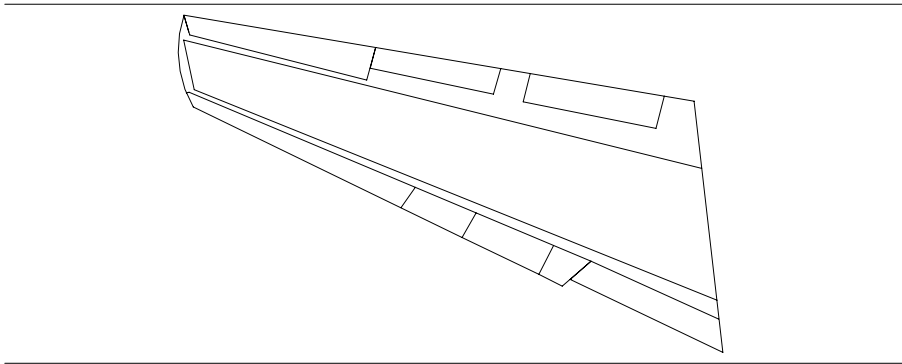

**Collection Pan:**

<u>Pan #</u>	<u>Area of Pan (dm<sup>2</sup>)</u>	<u>Weight of Pan (g)</u>		<u>Depth of Snow (cm)</u>	<u>Collection Time (hh:mm:ss)</u>		<u>Rate</u>
		<u>Before</u>	<u>After</u>		<u>Start</u>	<u>End</u>	
_____	14.90	_____	_____	_____	_____	_____	_____
_____	14.90	_____	_____	_____	_____	_____	_____
_____	14.90	_____	_____	_____	_____	_____	_____
_____	14.90	_____	_____	_____	_____	_____	_____
_____	14.90	_____	_____	_____	_____	_____	_____
_____	14.90	_____	_____	_____	_____	_____	_____

**Comments:** \_\_\_\_\_  
 \_\_\_\_\_  
 \_\_\_\_\_  
 \_\_\_\_\_

**Handwritten by:** \_\_\_\_\_  
**Measured by:** \_\_\_\_\_

FIGURE 2.8  
**PRESSURE TEST**  
 FORCED AIR DEICING TRIALS

Run #	Start Time (hh:mm:ss)	End Time (hh:mm:ss)	Deicing Mode (Air, Air/Fluid, Fluid)	Distance from Nozzle to Sensor (m)	Height of Nozzle relative to Sensor (m)	Force (kg)

**Note:** Runs must extend over an interval longer than one minute.

FIGURE 2.9  
**MEASURE OF NOISE LEVEL**  
**FORCED AIR DEICING TRIALS**

Run #	Location of Nose Sensor relative to Deicing Vehicle and Air Nozzle (Sketch setup if helpful)	Horizontal Distance from Air Nozzle (m)	Sensor Height above Ramp (m)	Noise Level (dB on A scale)

## 2.6 Equipment

A complete list of equipment is included in Appendix B.

A Vestergaard Elephant : deicing vehicle operated by AéroMag 2000 at Dorval Airport was retrofitted with a Vestergaard forced air deicing system for these tests. The vehicle and the installed forced air deicing system are shown in Photos 2.17 and 2.18. In Photo 2.18, an APS test video camera can be seen installed in the bucket. The entire forced air system was installed at the operator bucket. A centrifugal blower mounted at the rear of the bucket (Photo 2.19) delivered the forced air. The manufacturer reports that the blower is hydraulically driven, running at 7 600 rpm, and delivers approximately 4 000 m<sup>3</sup>/h at an air pressure of approximately 3 psig.

The temperature of the delivered air is ambient plus 25°C due to heat of compression. Manufacturer's data on air velocity as a function of distance are shown in Figure 2.10. A fluid nozzle positioned with the air nozzle outlet (Photo 2.20) enables injection of Type I or Type IV fluid from the existing truck tanks.

AéroMag 2000 moved the vehicle to and from the NRC Canada CEF in Ottawa for the trials.

A JetStar test wing owned by Transport Canada was positioned in the cold chamber to serve as the test surface for the trials under precipitation. Figure 2.11 shows the wing set-up in the cold chamber, with the deicing vehicle in position to spray. The wing surface was cleaned with isopropyl alcohol after Type I fluid trials. It was then protected with a tarpaulin (Photo 2.21) until start of the next test.

Thermistor probes were mounted on the wing surface to track wing temperature as heat was transferred to the wing from the fluid or air stream. A data logger recorded wing temperatures at 8-second intervals during the course of the tests.

Two clocks with large digital displays (Photo 2.22) were positioned near the wing to provide a standard time reference for observers and for photo documentation.

A grid composed of retro-reflective tape applied in one-meter squares was marked on the chamber door on the side of the wing opposite the deicing vehicle. This served as a visual reference when assessing loss of visibility and the projectile nature of ice or snow when subjected to blown air.

FIGURE 2.10

# AIR VELOCITY OF VESTERGAARD FORCED AIR SYSTEM

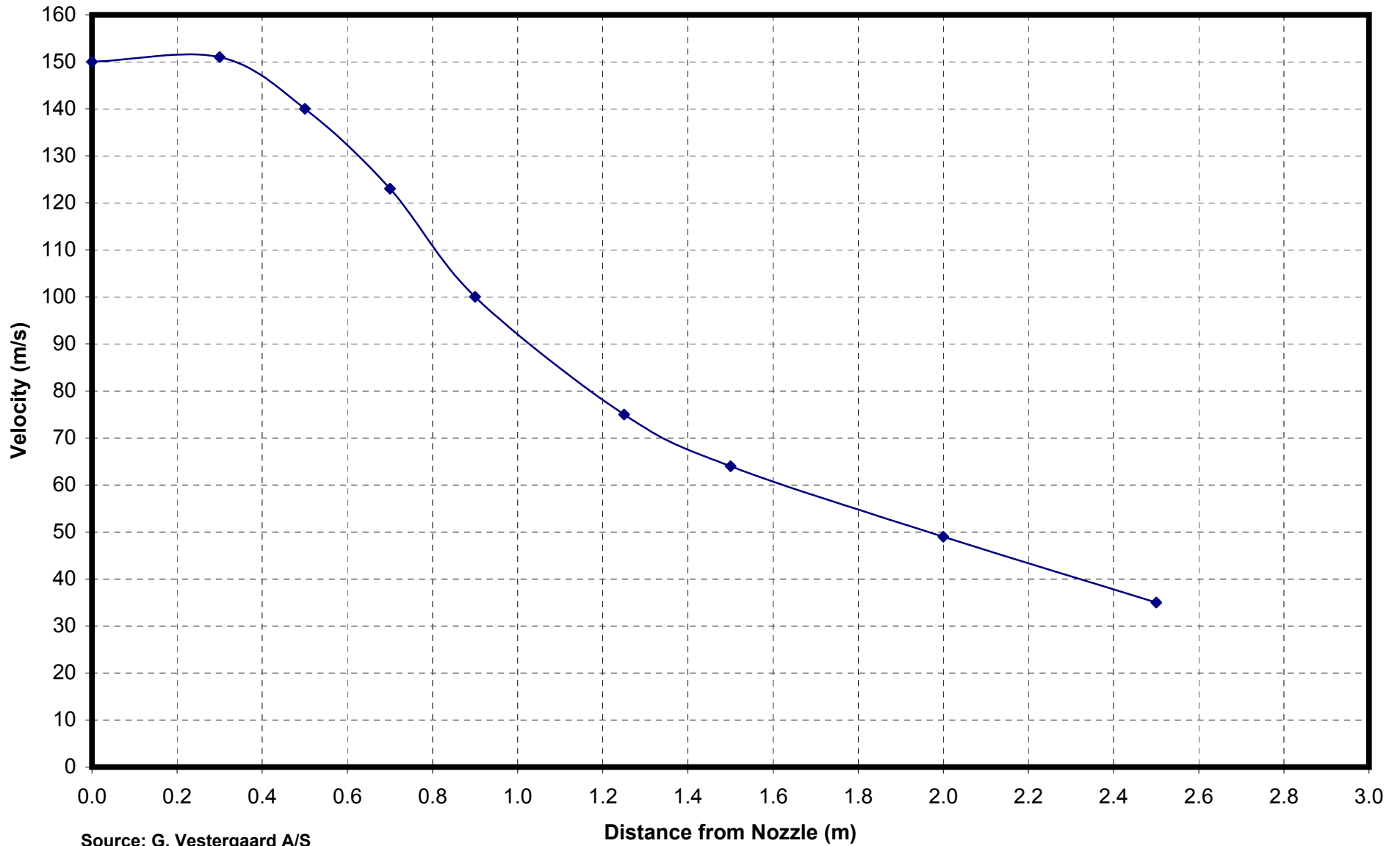

Source: G. Vestergaard A/S



**FIGURE 2.11**  
**TEST WING AND DEICING VEHICLE IN TEST FACILITY**

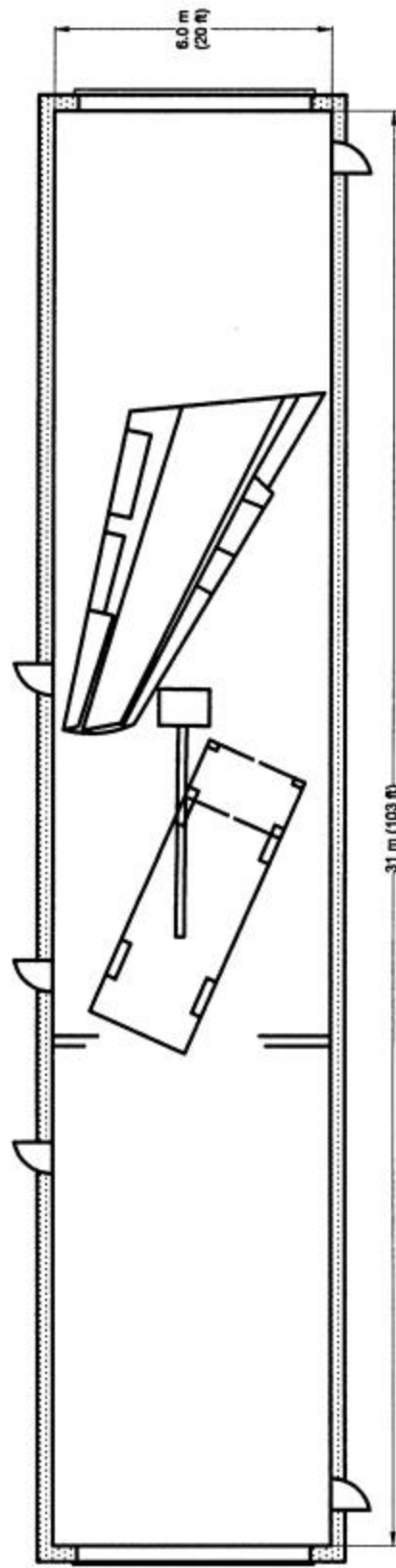

cm155460airboard airwing POSITION.DWG

Vertical standards marked with strips of red and white retro-reflective tape were positioned about the perimeter of the wing.

A similar grid was marked on a tarpaulin placed under the wing to serve as a reference for the distance that ice or snow was blown by the forced air.

A Cole-Parmer digital sound meter was used to record noise levels. The meter was mounted on a tripod to maintain the desired height above the ramp surface.

APS developed an apparatus to measure the force that down air, either alone or with injected fluid, exerts on the wing skin. This apparatus was composed of a load cell fixed underneath a rigid platform having a circular opening with an area of 161 cm<sup>2</sup> (25 in<sup>2</sup>). The apparatus was designed to conform to the Boeing maintenance manual, which indicates that any force directed on a surface area of 25 in<sup>2</sup> may not exceed 10 psig over that area. The load cell was a Cole-Parmer unit with capacity of 600±0.5 lb. A free-floating disc within the aperture sat directly on the load cell. In use, the force of the air stream directed at the disc was transmitted to the load cell. The load cell provided a real-time display and a digitized data output on an RS232 port.

Fluid samples for viscosity tests were preserved in small wide-mouth glass bottles with screw caps. Viscosity levels of the samples were measured with a Brookfield Digital Viscometer (Model DV-1+) fitted with a thermostat-controlled recirculating fluid bath and micro-sampling option. Fluid samples of 10 mL were centrifuged to remove air bubbles and cooled to 0° C. The spindle size used was Number 31 at 0.3 rpm.

### 2.7 Fluids

Fluids used in these trials were SAE Type I (UCAR ADF) and Type IV (UCAR Ultra+). The Type I fluid was heated in the truck tank to typical operating temperature (80 to 85°C) both when used as injected fluid in the air stream, and for reference trials using the standard Akron nozzle. The fluid temperature was measured at the nozzle for each test.

### 2.8 Personnel and Participation

The NRC Canada CEF staff provided technical support during trials at that facility.

The trials were observed by representatives of several airlines and of different manufacturers of deicing vehicles, as well as the FAA and Transport Canada. An attendance list is provided in Appendix C.

APS designed, coordinated, and conducted the trials.

AéroMag 2000 provided a Vestergaard Elephant : deicing vehicle from its Dorval Airport operation, on which the forced air deicing system had been installed. Transportation of the vehicle between Dorval Airport and the NRC Canada facility at Ottawa International Airport was provided by AéroMag 2000.

G. Vestergaard A/S provided and installed the forced air deicing system and operated it during the trials, assisted by AéroMag 2000.

Hudson General provided a glycol recovery truck from its Ottawa Airport location, and collected and disposed of the sprayed fluid.

Photo 2.1  
Digital Sound Meter



Photo 2.2  
Sound Meter Test



Photo 2.3  
Noise Sensor Enclosed in Hearing Protector



Photo 2.4  
Video and Laptop Monitors



Photo 2.5  
Reference Grids on Wall and Floor



Photo 2.6  
Device to Measure Force of Air Stream



Photo 2.7  
Measuring Air Stream Force at Close Range



Photo 2.8  
Measuring Air Stream Force at Longer Range

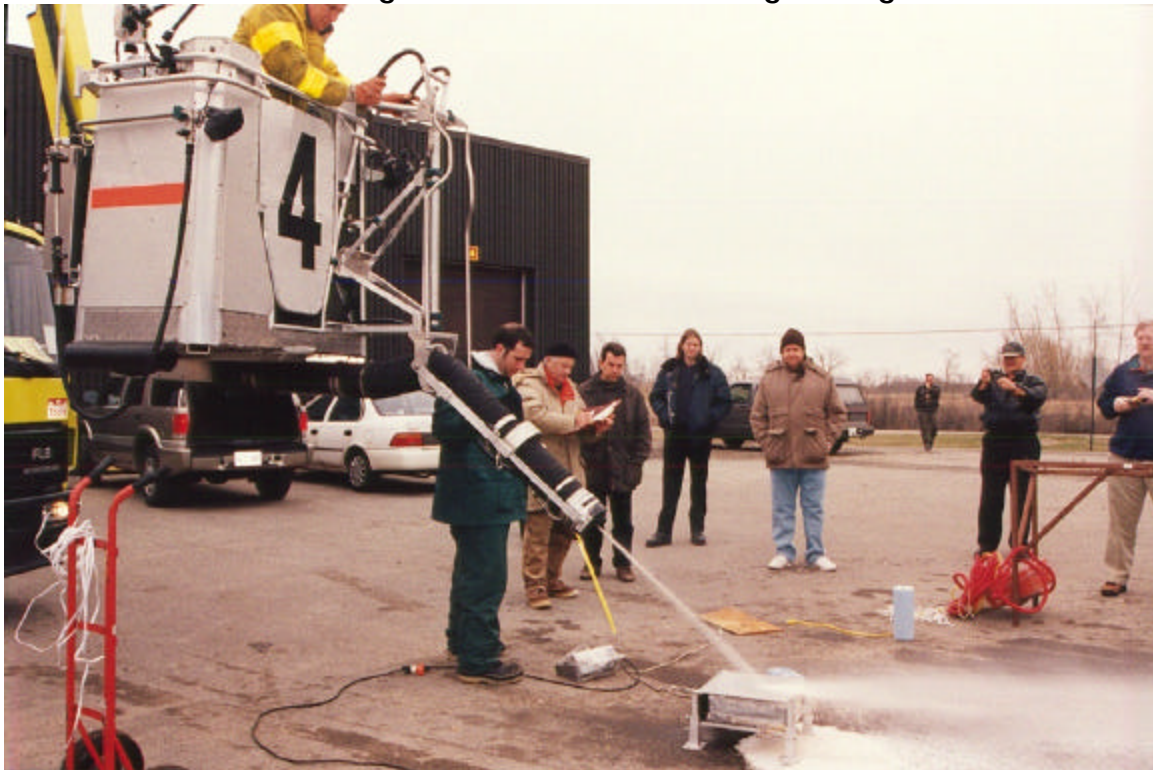

Photo 2.9  
Adjusting Distance and Angle of Forced Air Stream



Photo 2.10  
Measuring Surface Temperature at Close Range





Photo 2.11  
Measuring Surface Temperature at Longer Range



Photo 2.12  
Monitoring for Refreezing



Photo 2.13  
Thermistor Probe on Wing

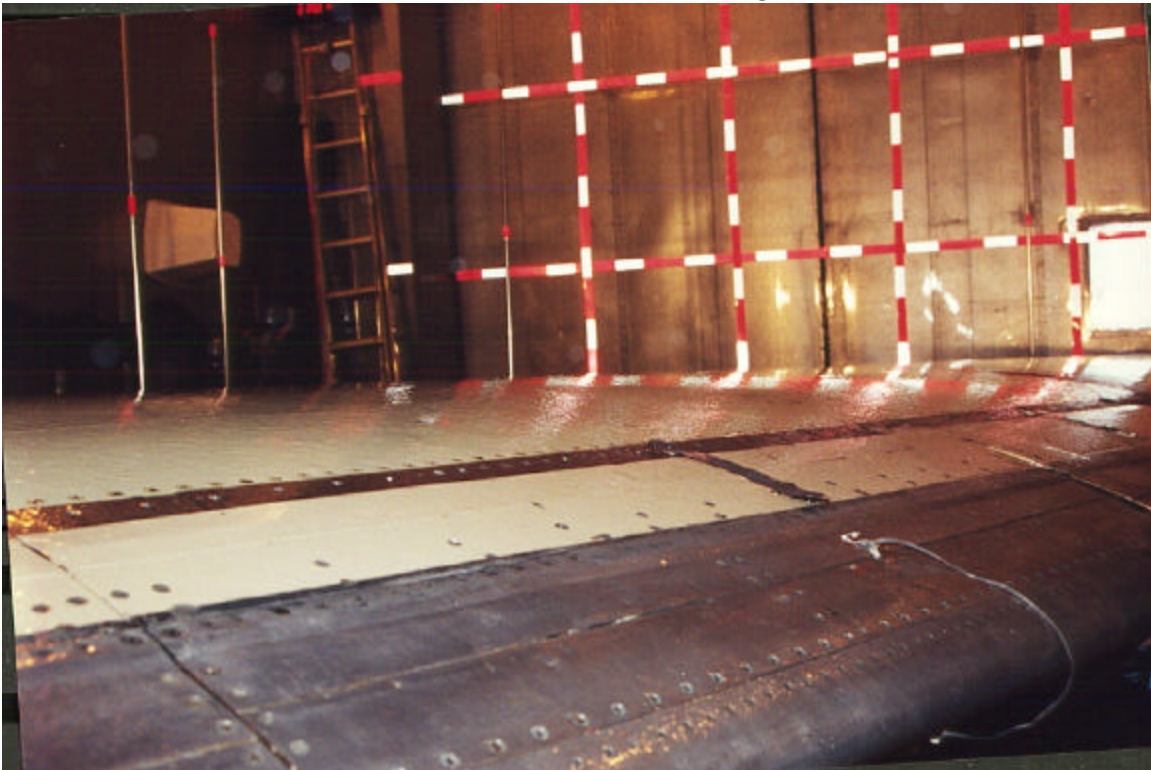

Photo 2.14  
Leading Edge Slat Lowered to Examine Residue



Photo 2.15  
Examining Surfaces Exposed by Lowering Leading Edge Slat



Photo 2.16  
Brookfield Digital Viscometer Model DV-I+ and Temperature Bath



Photo 2.17  
Vestergaard Forced Air Deicing System



Photo 2.18  
Forced Air System Installed on Bucket



Photo 2.19  
Centrifugal Blower



Photo 2.20  
Fluid Injection Nozzle

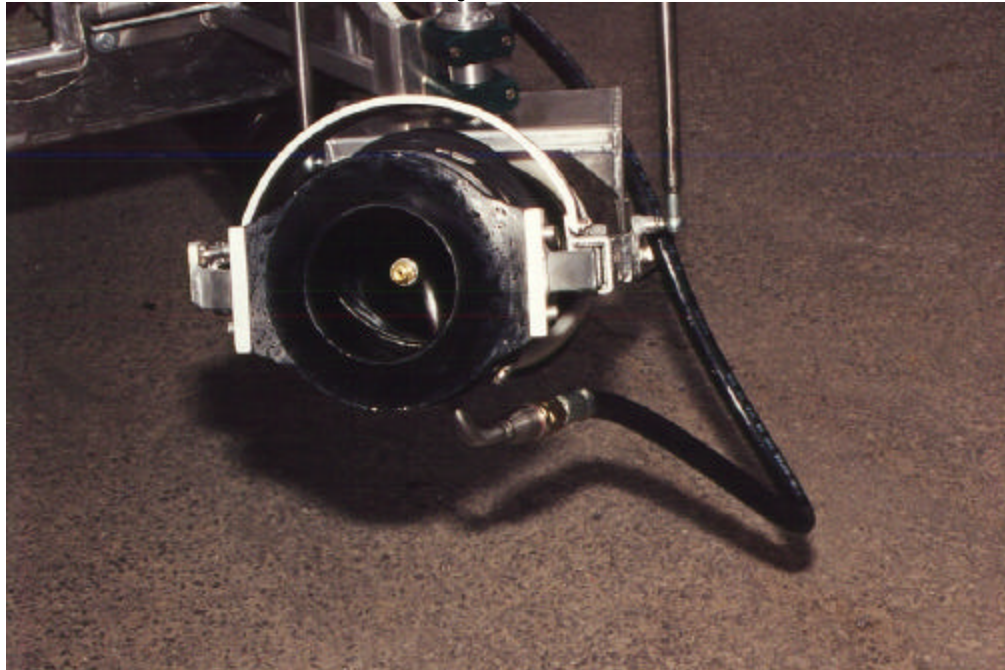

Photo 2.21  
Wing Protected with Tarpaulin

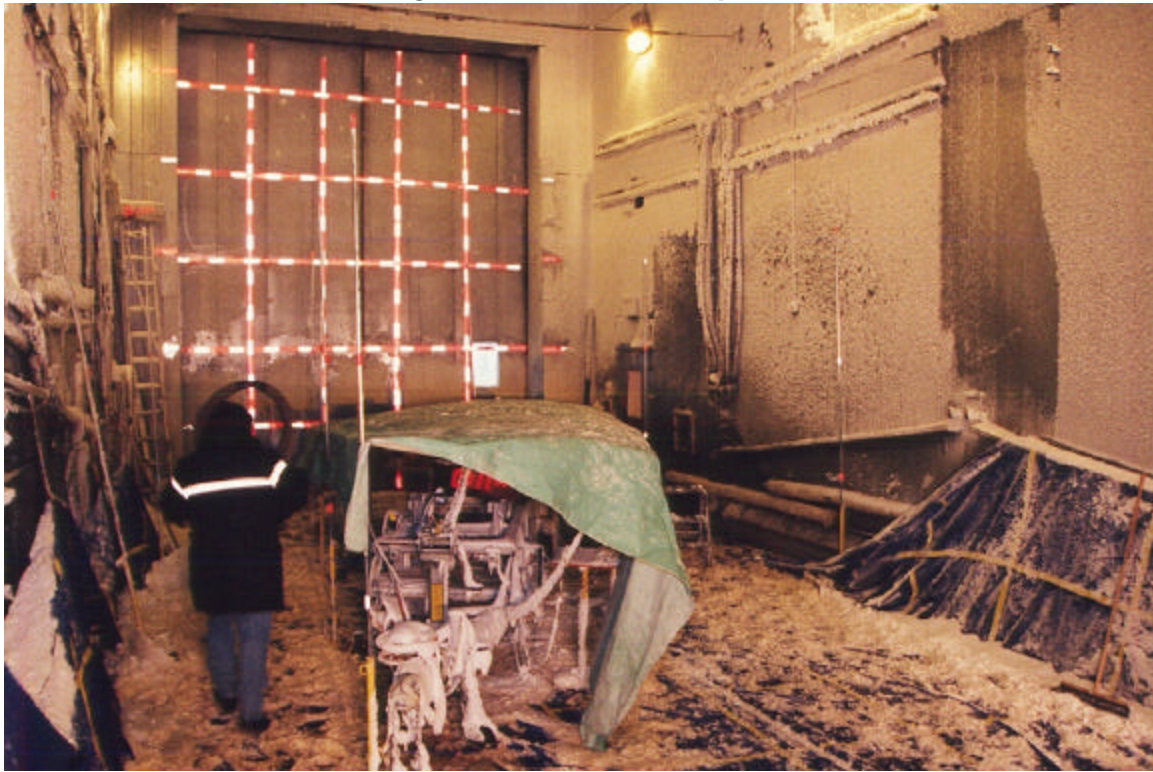

Photo 2.22  
Digital Clock



### 3. DESCRIPTION AND PROCESSING OF DATA

#### 3.1 Overview of Tests

Tests were conducted at the NRC Canada CEF from April 17 to 20, 2000. A history of trials conducted is shown in Table 3.1.

#### 3.2 Description of Data Collected and Analysis

##### 3.2.1 Noise Levels

The noise level data were portrayed in a schematic showing noise levels at positions measured relative to the deicing vehicle. Figure 3.1 presents the results.

The circled values are noise levels measured when the noise sensor was encased between the two earmuffs of a hearing protector.

##### 3.2.2 Visibility

Documentation of the effect on visibility consisted of observers' comments as well as videotape and photographic records.

In these trials, the major contributor to loss of visibility was the vapour produced in the enclosed area when heated Type I fluid was applied. When the standard nozzle was used, the cold chamber doors had to be opened to allow the vapour to escape and to thereby regain sufficient visibility to continue deicing the wing. Application of fluid by the injection system did not produce vapour to the same extent, except in the case of wet snow when a longer spray time was needed to clean the wing (over 5 minutes).

During some trials of air alone and air with injected fluid, the artificial snow generation was halted during the deicing process to evaluate any detrimental effect on visibility of snow blown about by the forced air deicing system.

TABLE 3.1  
**FORCED AIR DEICING TRIALS – TEST HISTORY**  
**NRC CANADA, OTTAWA, APRIL 17 - 20, 2000**

Seq. ID#	DATE	OAT (°C)	PRECIPITATION CONDITION	ACCUMULATION THICKNESS	DEICING MODE	PURPOSE AND LOCATION OF TEST
1	17-Apr	-10	ZR (16 g/dm <sup>2</sup> /hr)	0.25 cm (0.1")	Air	Examine ice projectiles, elapsed time before refreezing, visibility, and residue in quiet areas. Conducted in the NRC Canada CEF.
2	17-Apr	-10	ZR (16 g/dm <sup>2</sup> /hr)	0.25 cm (0.1")	Standard Type I fluid spray	
3	17-Apr	-10	ZR (16 g/dm <sup>2</sup> /hr)	0.25 cm (0.1")	Air/injected Type I fluid	
4	18-Apr	-17	Dry snow	5 to 7.5 cm (2 to 3")	Air/injected Type I fluid	
5	18-Apr	-17	Dry snow	5 to 7.5 cm (2 to 3")	Standard Type I fluid spray	
6	19-Apr	-17	Dry snow	5 to 7.5 cm (2 to 3")	Air	
7	19-Apr	-16	Wet snow	5 to 7.5 cm (2 to 3")	Air	
8	20-Apr	-14	Wet snow	5 to 7.5 cm (2 to 3")	Air/injected Type I fluid	
9	19-Apr	-16	Dry	Ice samples 1/2" thick	Air	Projectile test Conducted in the NRC Canada CEF
10	19-Apr	-16	Dry	Ice samples 1/4" thick	Air	
11	18-Apr	5	Dry	N/A	Air	Pressure on wing skin Conducted outdoors at NRC Canada
12	18-Apr	5	Dry	N/A	Air/injected Type I fluid	
13	20-Apr	8	Dry	N/A	Injected fluid without air	
14	20-Apr	8	Dry	N/A	Standard Type I fluid spray	
15	20-Apr	8	Dry	N/A	Air/injected Type IV fluid	Shearing of Type IV fluid Conducted outdoors at NRC Canada
16	20-Apr	8	Dry	N/A	Injected fluid without air	
17	20-Apr	8	Dry	N/A	Standard Type IV fluid spray	
18	20-Apr	8	Dry	N/A	Type IV wand	
19	19-Apr	8	Dry	N/A	Air	Heat at wing skin Conducted outdoors at NRC Canada
20	19-Apr	8	Dry	N/A	Air/injected Type I fluid	
21	18-Apr	4	N/A	N/A	Air	Measure noise levels Conducted outdoors at NRC Canada



FIGURE 3.1  
**NOISE MEASUREMENTS (dBA)**  
**FORCED AIR DEICING TRIALS**  
**OAT 4°C**  
 NRC CANADA CEF OTTAWA, APRIL 17 - 20, 2000

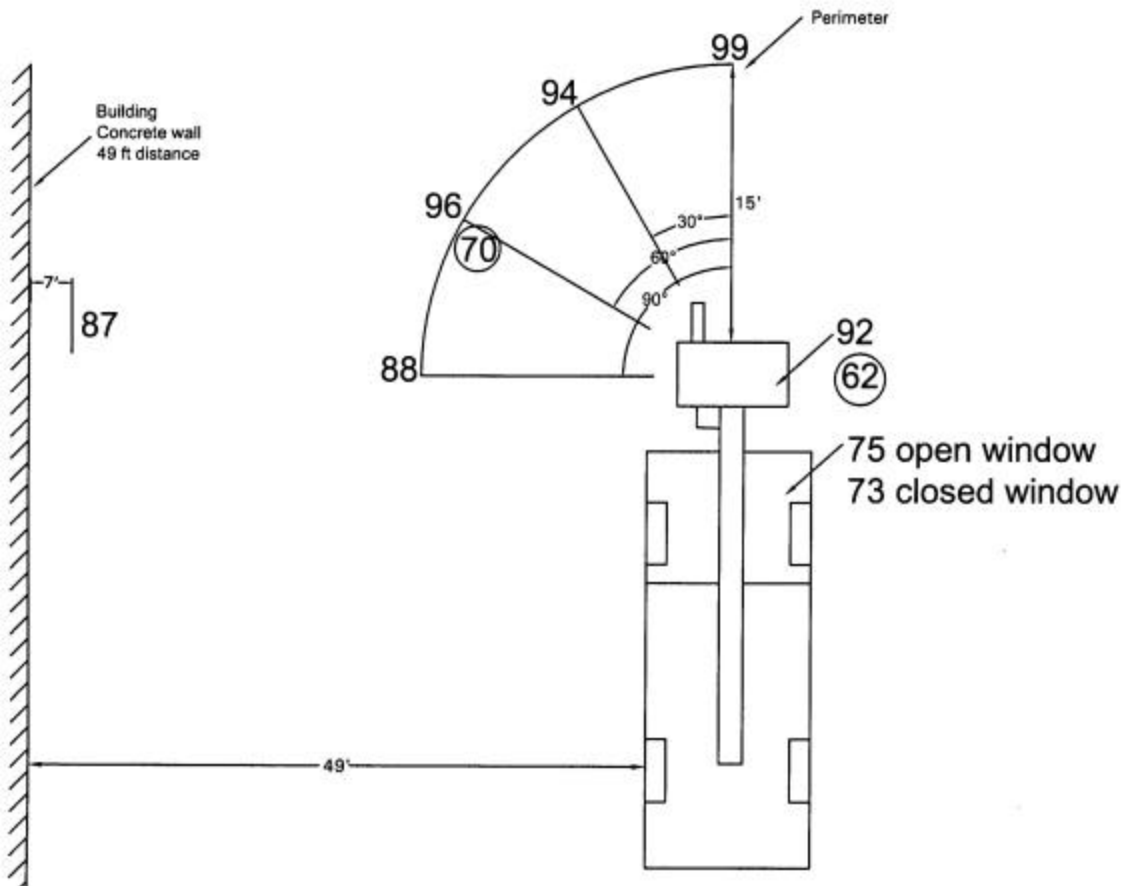

Note: (1) Circled values are with noise sensor enclosed within hearing protector  
 (2) IATA AHM 910. The noise level shall be kept to a minimum but shall not exceed 85 dBA at a distance of (4.6 m) 15 ft. from the perimeter of the vehicle and at (1.5 m) 5 ft. above the ground.

cm1589/reports/forced air/Noise Measurements.DWG

### 3.2.3 Ice and Snow Projectiles

Videotape records comprise the major part of the documentation of the nature of blown ice and snow during the deicing process. Selected videotape segments were shown in a presentation of test results given to industry representatives at SAE Ground Deicing meetings.

The grid-marked tarpaulin positioned on the floor under the wing did not prove to be useful as the grid markings were hidden by the snowfall and slush accumulated from ongoing tests. The slush could not easily be removed between tests because of the wing structure, and was removed only at the end of the test session.

For tests involving blowing pre-formed ice pieces from the wing surface, weight and dimensions of the random-sized ice pieces were recorded. The locations of the individual ice pieces were noted on a diagram of the wing surface. These ice pieces were shattered by the effect of the air stream, either from the direct force on the ice or by lifting and then dropping the ice on the wing surface.

### 3.2.4 Pressure on Wing Skin

During these trials, the load cell display was monitored to identify the highest force experienced while the stream of air, air/fluid combination or fluid was directed at the sensor disc. The operator of the forced air deicing system was instructed as to where to aim the stream to produce the highest force.

This data was charted in graph form to portray the force on the wing skin as a function of distance and angle of incidence. Figure 3.2 is an example of such a chart. Pressure values were calculated by dividing the force exerted by the disc area.

### 3.2.5 Temperature of Wing Skin

While the stream was directed at the test plate, the temperature reading was observed until no further increase was seen. The maximum temperature indicated was then recorded.

This data was charted in graph form to portray the wing skin temperature as a function of distance, as presented in Figure 3.3. The angle of incidence was normal to the plate for these trials.

FIGURE 3.2  
**FORCE ON A 25 in<sup>2</sup> DISC**  
**FORCED AIR WITHOUT FLUID INJECTION**  
FORCED AIR DEICING TRIALS – NRC CANADA CEF OTTAWA, APRIL 17-20, 2000

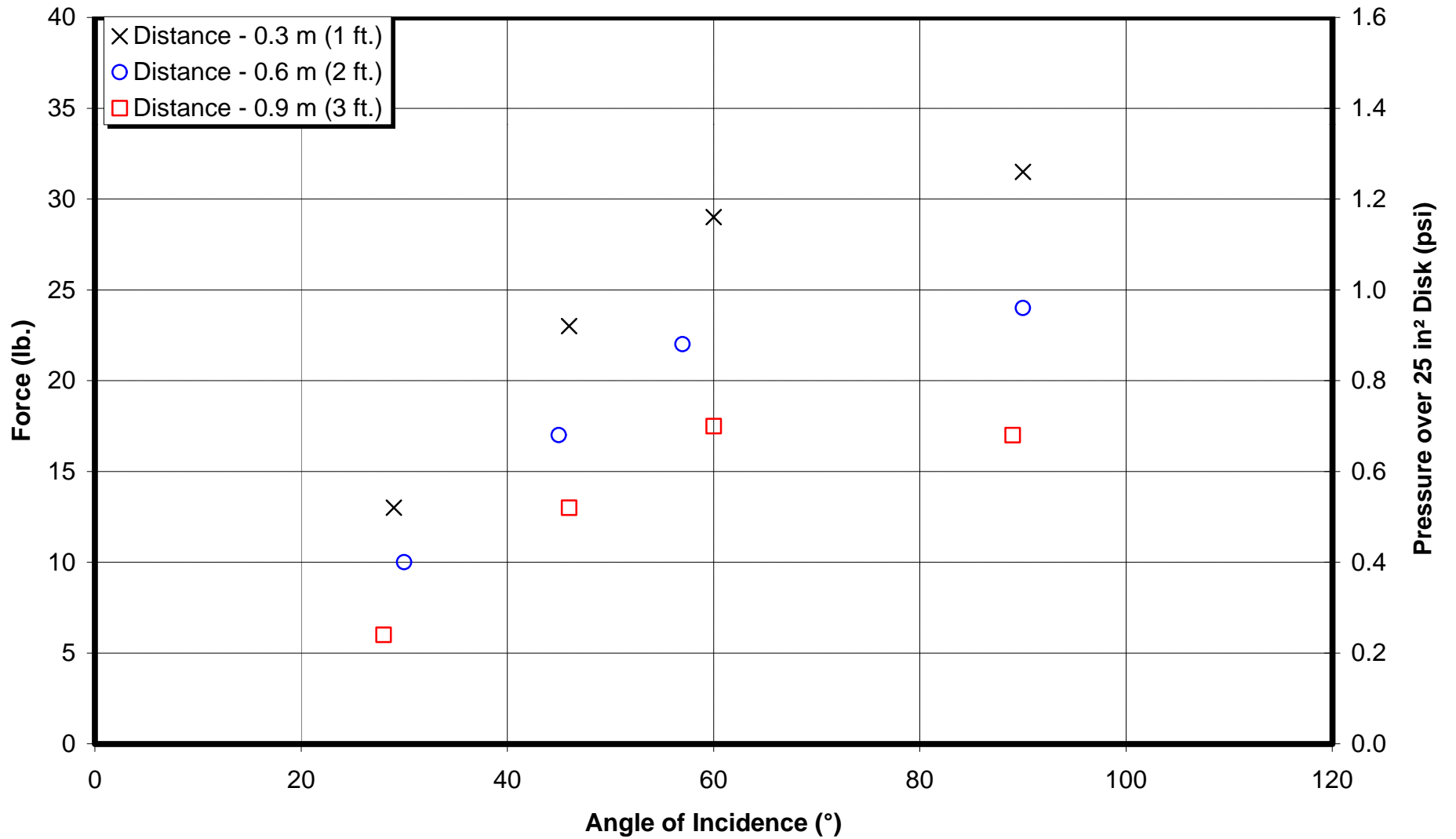
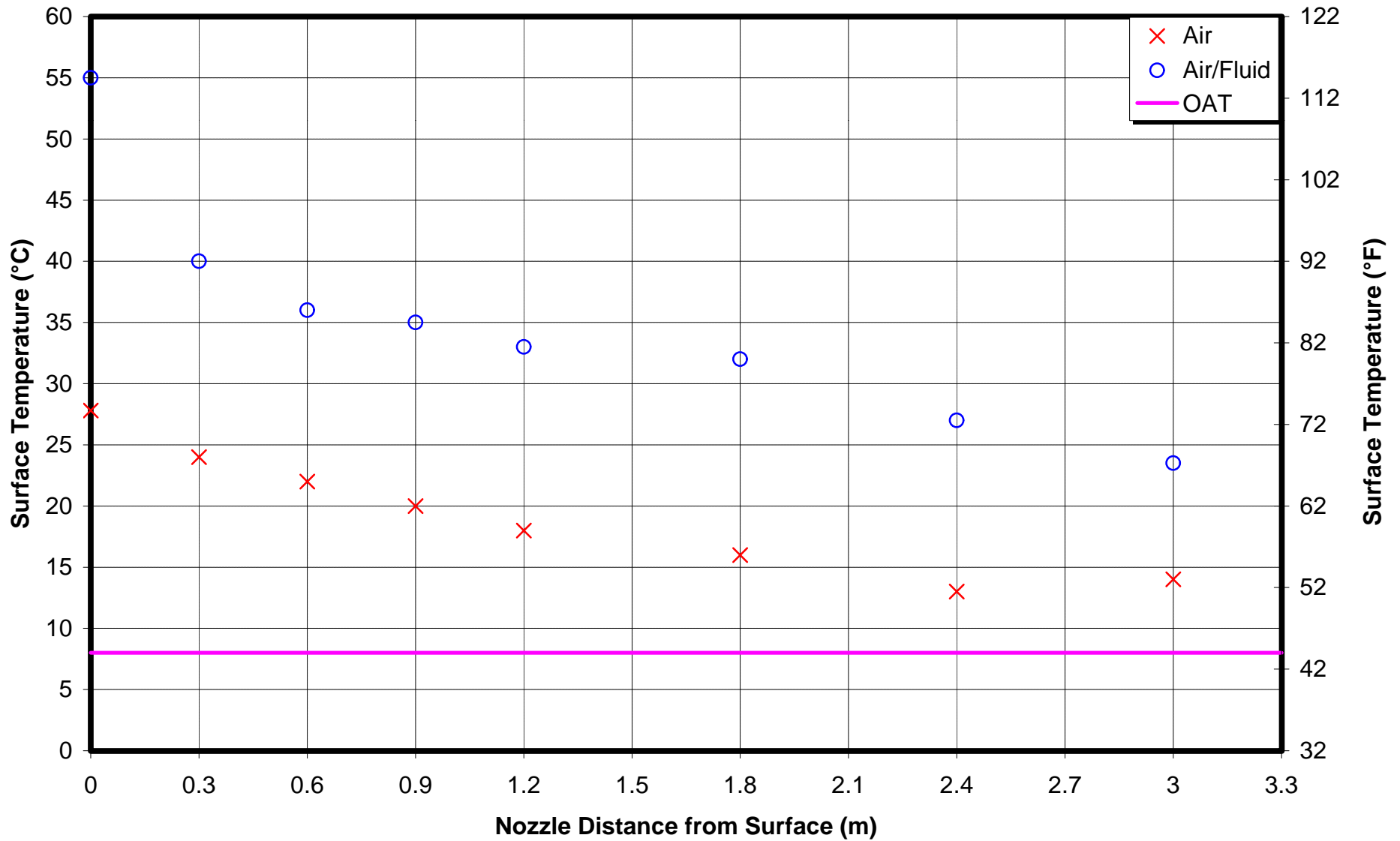

FIGURE 3.3

### WING SKIN TEMPERATURE VS. NOZZLE DISTANCE

FORCED AIR DEICING TRIALS – NRC CANADA CEF OTTAWA, APRIL 17-20, 2000



### 3.2.6 Elapsed Time until Refreezing

A typical completed data form recording time to refreeze is shown in Figure 3.4. Start and end times of the deicing process were recorded on the general form (Figure 3.5).

These data are summarized in tables for each type of contamination. Table 3.2 is an example.

Wing skin temperature data recorded by the thermistor probes and data loggers were charted to produce temperature decay profiles over time. Figure 3.6 is an example. These profiles show the temperature rise resulting from the application of heated fluid or forced air, and illustrate the rate of cooling thereafter. The elapsed time until the wing skin temperature cools to 0°C and to ambient temperature is the key information provided by these profiles. In section 4, these profiles are compared, and differences in transfer of heat to the wing surface between the different methods of deicing are discussed.

### 3.2.7 Residue in Quiet Areas

At the end of the deicing operation, the leading edge slat was lowered and any fluid residue remaining in the recess was collected, weighed, and measured for strength using a Brixometer. A typical completed data sheet is shown in Figure 3.7.

### 3.2.8 Shearing of Type IV Fluid

Viscosity values as measured by the Brookfield viscometer for the various types of fluid applications tested were charted as a function of distance from nozzle to surface, as shown in Figure 3.8.

FIGURE 3.4  
**ICING FORM FOR JETSTAR WING – COMPLETED**  
**FORCED AIR DEICING TRIALS**

DATE: 17-Apr-00

RUN #: 1

Sequence # 2

**RECORDING INFORMATION:**

- At time of 1st freezing: - Note location and time on wing form. Advise other team members.
- 5 minutes after 1st freezing: - Record patterns of ice on the wing form.  
- Measure and record ice thickness and roughness.
- Wing Cavity Inspection: - Record appearance of any ice formation. Use additional forms as needed.

Initial Snow/Ice Depth	
Location	Depth (Mils)
1	112
2	96
3	80
4	112
5	104

Refrozen Snow/Ice Patches	
Location	Thickness
6	24 (14:35)
7	16 (14:39)
8	18 (14:40)
9	16 (14:42)
10	16 (14:43)

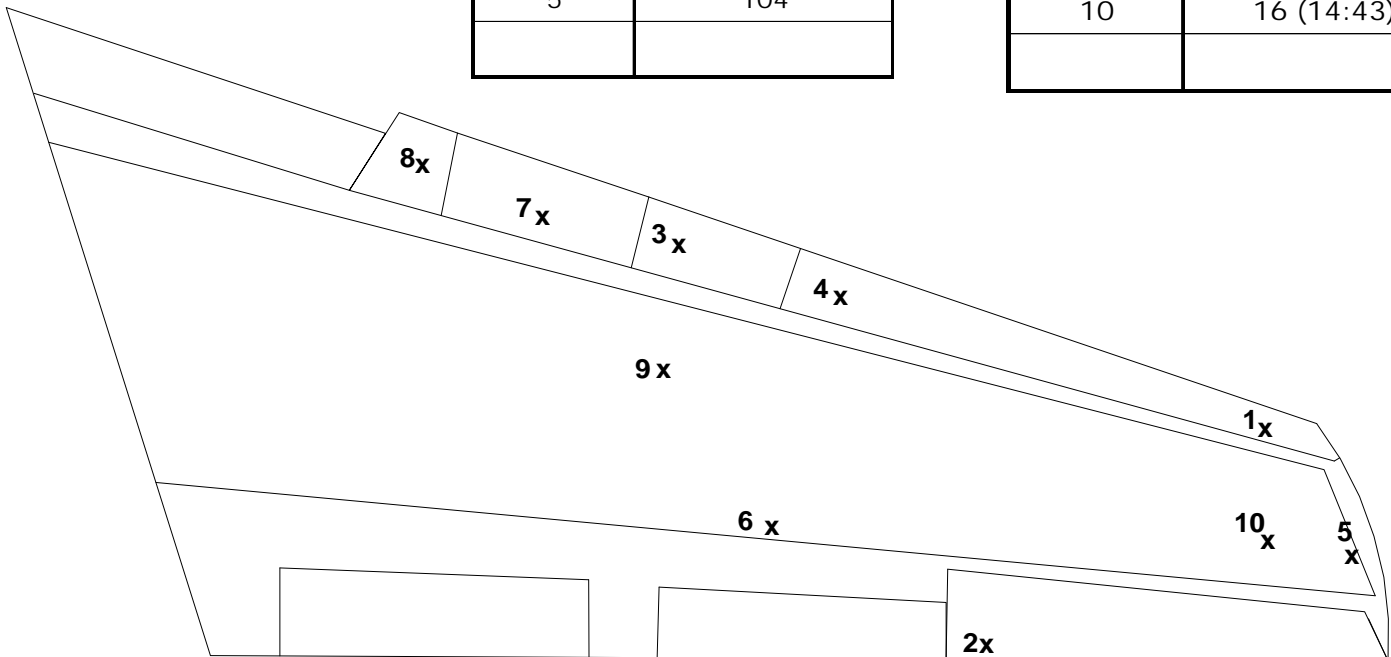

COMMENTS: \_\_\_\_\_

ICING RECORD BY: M. Hanna

\_\_\_\_\_  
 \_\_\_\_\_

HANDWRITTEN BY: \_\_\_\_\_

FIGURE 3.5  
**GENERAL FORM (EVERY TEST) – COMPLETED**  
**FORCED AIR DEICING TRIALS**

Date: 17-Apr-00

Aircraft Type: JetStar Wing

Run #: 1 Sequence 2

DRAW DIRECTION OF TRUCK WRT WING:

Type of Application     AIR  
                                    AIR/INJECTED FLUID  
                                    FLUID

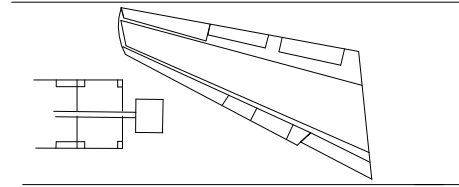

Truck #: 4

Type I Fluid Nozzle Type: Akron

Distance from Nozzle to Wing \_\_\_\_\_ m

Angle of Jet Blast  
 relative to Horizontal: \_\_\_\_\_ °

<i>PRECIPITATION</i>			
Actual Start Time:	<u>12:07</u> hh:mm:ss	Actual End Time:	_____ hh:mm:ss
Start Temperature	<u>-10.7</u> °C	End Temperature:	_____ °C

<i>DEICING APPLICATION</i>			
Actual Start Time:	<u>14:24:02</u> hh:mm:ss	Actual End Time:	_____ hh:mm:ss
Amount of Fluid Sprayed:	<u>250</u> <span style="border: 1px solid black; border-radius: 50%; padding: 2px;">L</span> / gal	Type of Fluid:	_____
Fluid Temperature:	Tank: <u>85</u> °C	Nozzle:	<u>60</u> °C
Fluid Brix:	<u>33.5</u>		

COMMENTS: Thermistor # 6 detached

\_\_\_\_\_

\_\_\_\_\_

\_\_\_\_\_

\_\_\_\_\_

\_\_\_\_\_

MEASUREMENTS BY: \_\_\_\_\_

HANDWRITTEN BY: \_\_\_\_\_

TABLE 3.2  
**REMOVAL OF ICE 0.25 cm (0.1") THICK**  
**AMBIENT TEMP. = -10°C, FREEZING RAIN**

Test ID #	Deicing Mode	Fluid		Time to Deice (min)	Time to Refreeze (min)	Quiet Area (g/brix)	Comment
		Temp (°C)	Qty (L)				
1	Air		0				Unable to remove ice
3	Air/ Injected Fluid	60	174	7:23	3:52	LE Top=11 g @ 7 LE Cavity=11 g @ 20	Visibility OK - not greatly reduced due to vapour
2	Std Type I	60	250	3:11	8:22	LE Top=17 g @ 7 LE Cavity=25 g @ 20	Lost visibility @ 1 minute



**FIGURE 3.6**  
**WING SKIN TEMPERATURE PROFILES**  
**ID #2 – ICE 0.25 cm (0.1") THICK, STD TYPE I DEICING**  
**FORCED AIR DEICING TRIALS – APRIL 17, 2000**

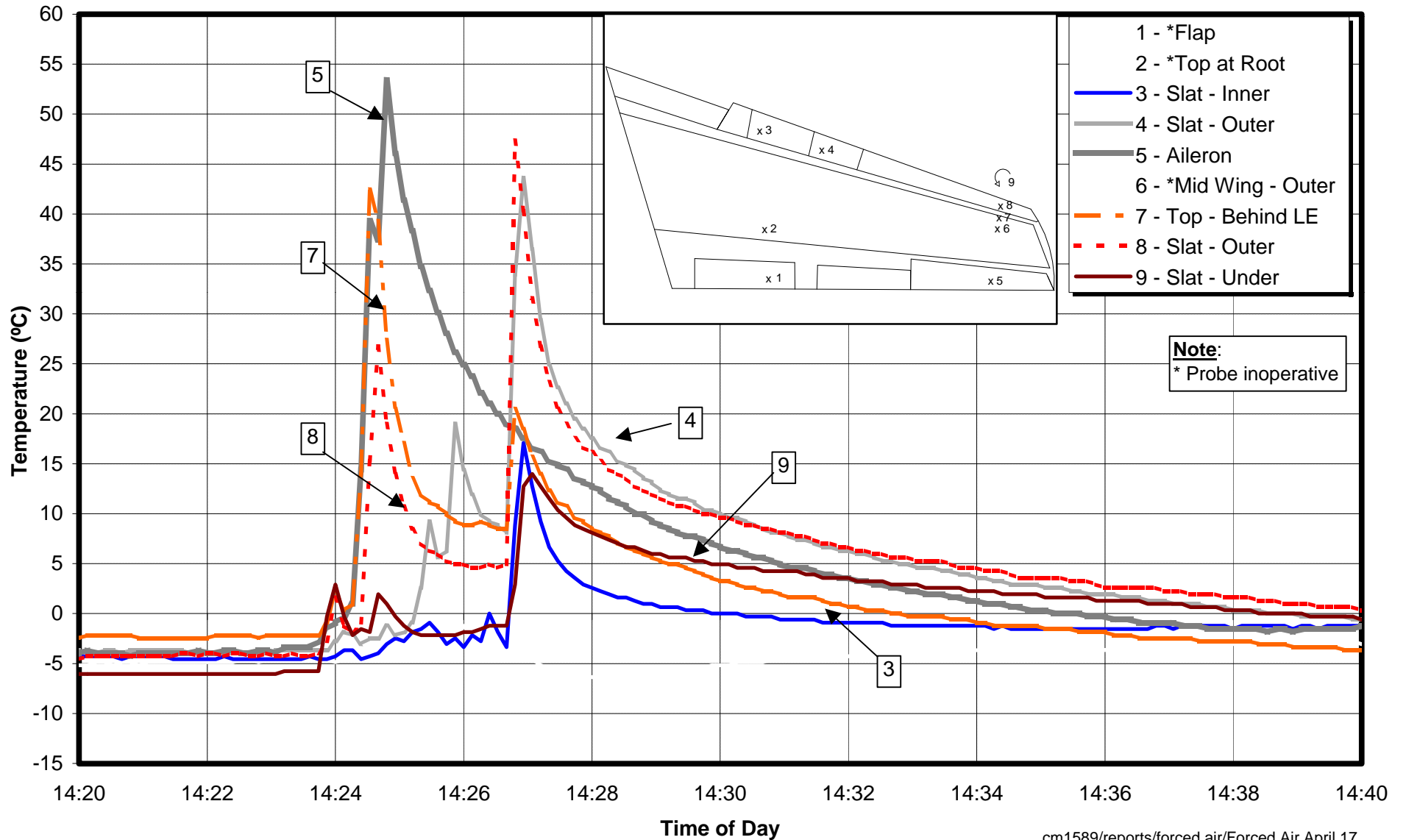

FIGURE 3.7

**QUIET AREA – RESIDUAL WATER ACCUMULATION TEST (COMPLETED)**  
**FORCED AIR DEICING TRIALS**

Date: 17-Apr-00

Type of Precipitation: ZR

Run #: 1 Sequence 2

OAT: -10 °C

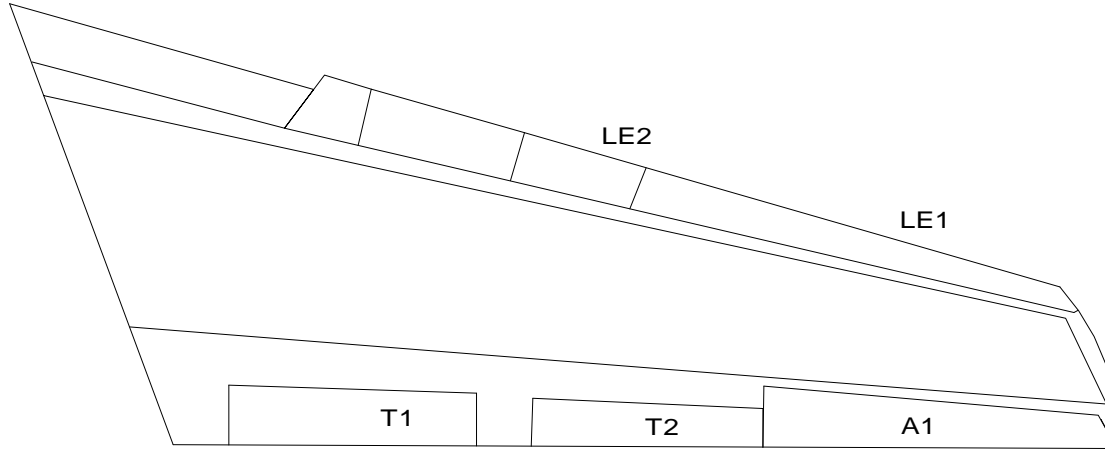

Tester	Location	Bucket Weight Before	Bucket Weight After	BRIX
Jennifer	LE1 Top	565	582	7
Phil	LE1 Bottom	572	596	20
	LE2 Top			
	LE3 Bottom			
	T1			
	T1			
	A1			

Comments: \_\_\_\_\_

Recorded by: Jennifer

FIGURE 3.8  
**FLUID VISCOSITY VS. NOZZLE TYPE AND DISTANCE**  
**ETHYLENE GLYCOL-BASED TYPE IV FLUID**  
 SPINDLE 31, 10 min, 10 mL, 0°C, 0.3 RPM, CENTRIFUGED  
 FORCED AIR DEICING TRIALS – NRC CANADA CEF OTTAWA, APRIL 17-20, 2000

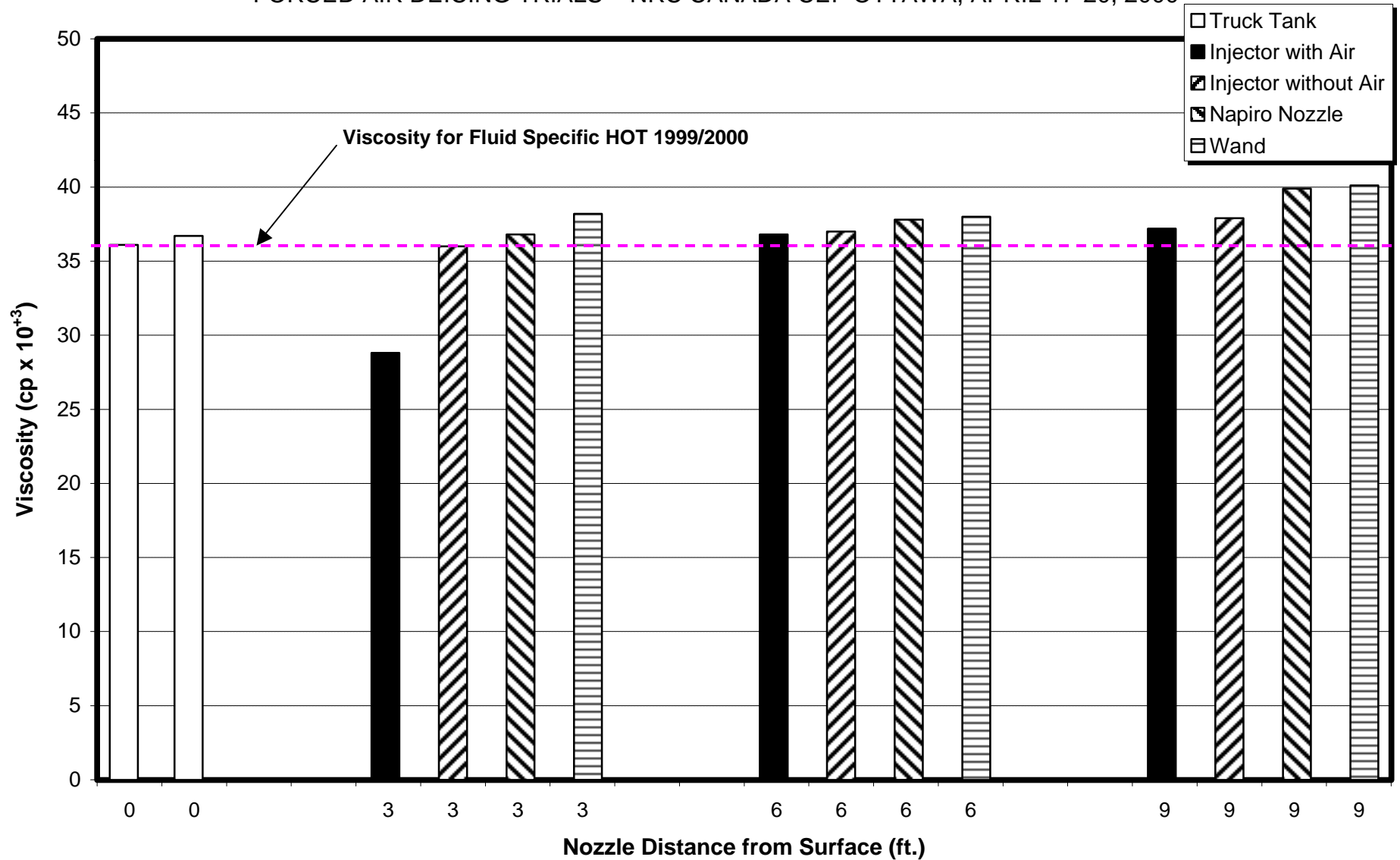

*This page intentionally left blank.*

## 4. ANALYSIS AND OBSERVATIONS

The results of testing for the various parameters are discussed in this section.

### 4.1 Noise Levels

Figure 3.1 shows noise levels measured at points around the deicing vehicle. For these trials, the bucket was positioned 10 ft. above the ramp.

At distances of 4.6 m (15 ft.) from the nozzle and at 1.5 m (5 ft.) above the ramp, noise levels varied from 88 to 99 dBA. These values are all above the maximum level of 85 dBA recommended in IATA AHM 910. However, with the noise sensor encased between the two earmuffs of a hearing protector, noise exposure was reduced to an acceptable level (e.g., dropping from 96 to 70 dBA).

At a point 42 ft. distant from the nozzle and 7 ft. from a concrete wall, the measured noise level was 87 dBA.

The noise level in the bucket was 92 dBA. This was reduced to 62 dBA with hearing protectors.

Unprotected noise levels in the cab were 75 dBA with the window open, and 73 dBA with the window closed.

### 4.2 Effect on Visibility

The greatest contribution to reduced visibility was the vapour generated by the application of heated fluid in an enclosed area. This was most pronounced for trials involving spraying with Type I fluid using the standard Akron nozzle. Fluid injected into the air stream generated somewhat less vapour. In severe conditions, the large access door to the chamber had to be partially opened to regain sufficient visibility for the operator to continue the wing deicing.

Snow (either wet or dry) blown by the forced air stream did not significantly degrade visibility.

### 4.3 Ice and Snow Projectiles

It was observed that the nature of snow removal using forced air was primarily by erosion, with snow being blown away as small particles. A few clumps of snow were lifted and fell to the floor at the wing perimeter.

The application of forced air alone was unable to remove the layer of ice that adhered to the wing. The air/fluid combination successfully removed the layer of ice, but less quickly than the standard method using the Akron nozzle.

With the air/fluid combination, small pieces of ice about the size of a coin were lifted and blown off the edge of the wing.

In a separate set of tests where pieces of ice 0.7 and 1.3 cm (0.5 and 0.25 in.) thick were placed on the wing, the large pieces of ice were broken up by the forced air stream, lifted, and then dropped back onto the wing surface. Through this process, the larger pieces were reduced to small pieces approximately 5 cm (2 in.) across. Some of these pieces were blown across the wing toward the wing root and then against the chamber door, about 3 m (10 ft.) distant. They fell about 1 m (3.3 ft.) in transit. The average horizontal velocity was calculated to be about 7 m/sec (16 mph).

### 4.4 Pressure on Wing Skin

Figures 4.1 to 4.4 chart the forces exerted on the 25 in<sup>2</sup> disc versus angle of incidence for different nozzle-to-surface distances.

A comparison of forced air to the air/fluid combination (Figures 4.1 and 4.2) showed no discernible difference in pressure on the wing. At a distance of 0.9 m (3 ft.) and a 45° angle of incidence (selected as being typical of field operations), the force on the disc (having an area of 25 in<sup>2</sup>) was 13 lb., equivalent to 0.5 psi over the entire disc. The maximum force recorded was 32 lb. (1.3 psi) produced with a nozzle distance of 0.3 m (1 ft.) and a 90° angle of incidence.

Forces at a nozzle distance of 0.3 m (1 ft.) were about 40 percent greater than at 0.9 m (3 ft.).

The force exerted by the injected-fluid-only configuration was very low (Figure 4.3), with a maximum value of 5 lb. or 0.2 psi.

**FIGURE 4.1**  
**FORCE ON A 25 in<sup>2</sup> DISC**  
**FORCED AIR WITHOUT FLUID INJECTION**  
 FORCED AIR DEICING TRIALS – NRC CANADA CEF OTTAWA, APRIL 17-20, 2000

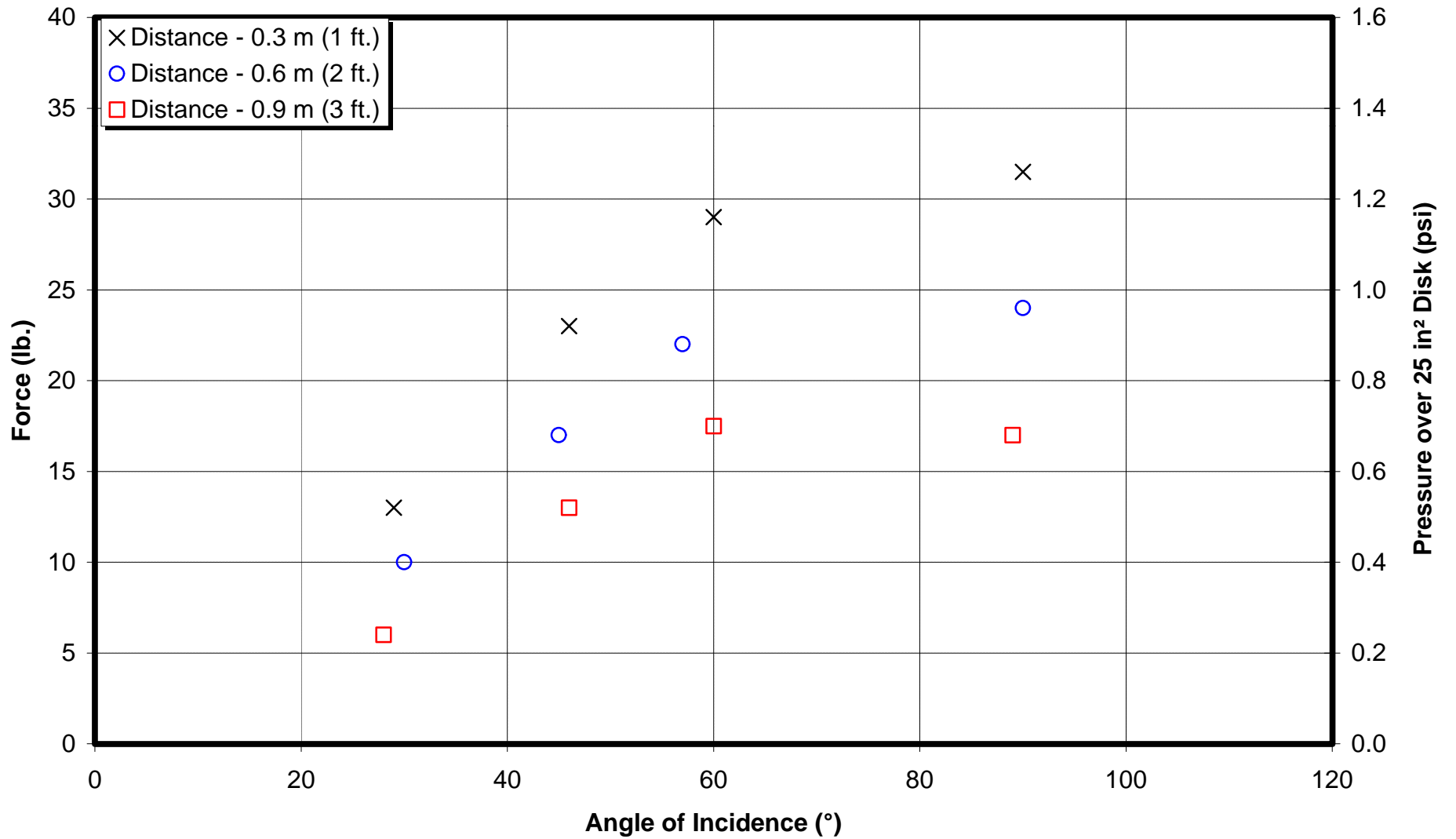

FIGURE 4.2  
**FORCE ON A 25 in<sup>2</sup> DISC**  
**FORCED AIR WITH FLUID INJECTION**  
FORCED AIR DEICING TRIALS – NRC CANADA CEF OTTAWA, APRIL 17-20, 2000

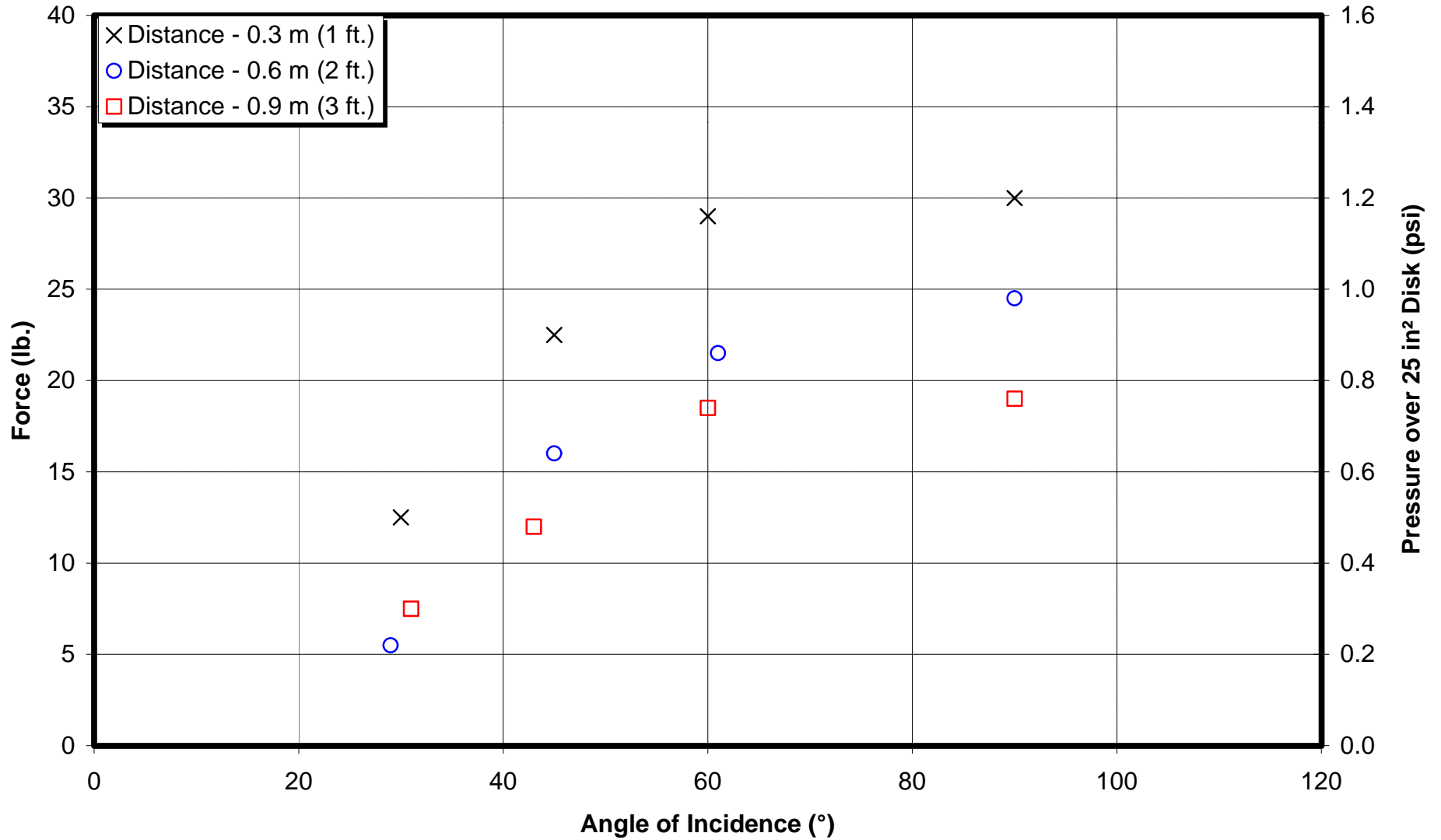
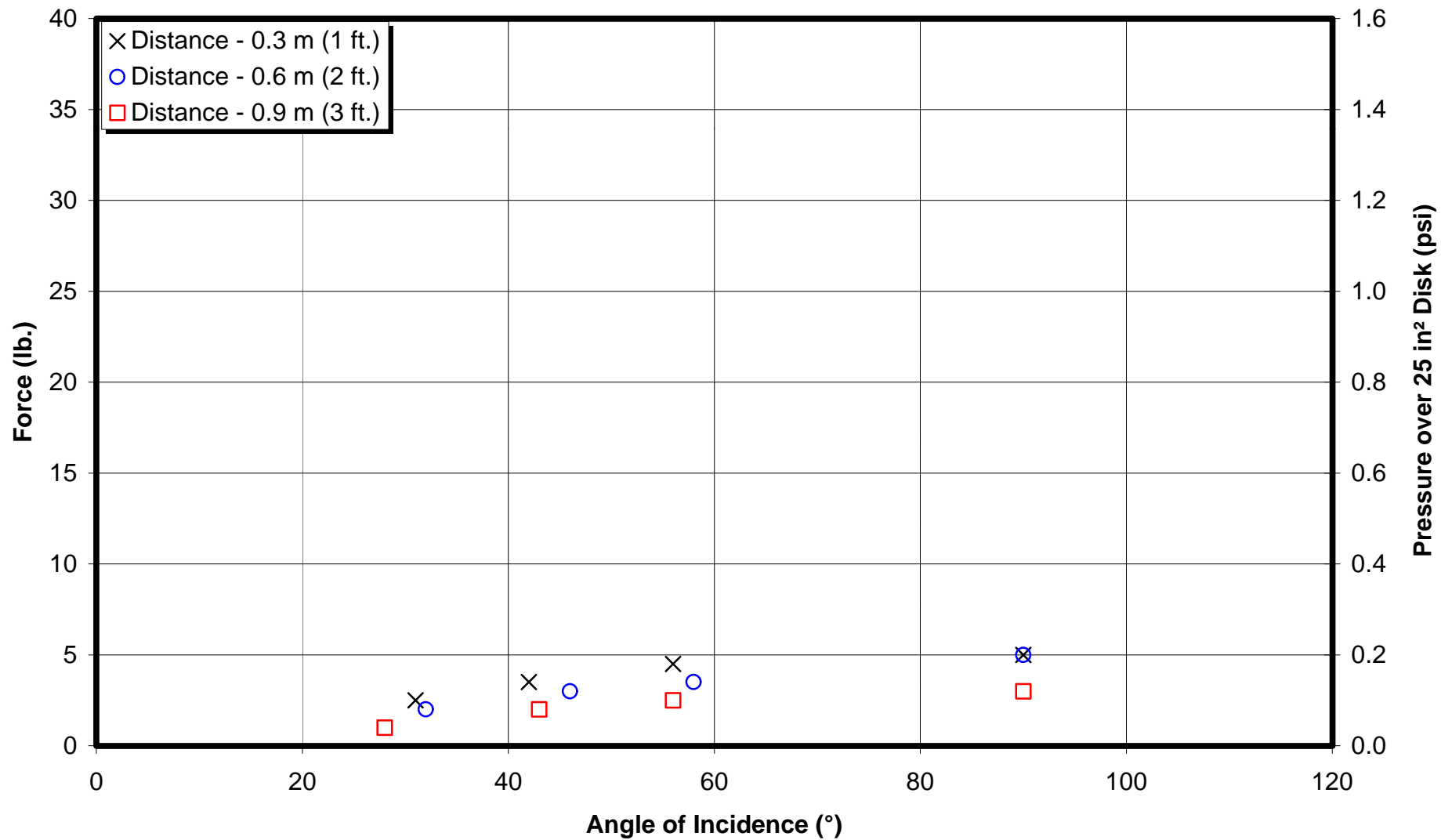



FIGURE 4.3  
**FORCE ON A 25 in<sup>2</sup> DISC  
FLUID INJECTION, NO AIR**  
FORCED AIR DEICING TRIALS – NRC CANADA CEF OTTAWA, APRIL 17-20, 2000



The force exerted by the Akron nozzle (Figure 4.4) was measured at greater distances more typical of the standard method of operating. When compared to the air and air/fluid test results at the 0.9 m (3 ft.) distance that was common to all nozzle configurations, the Akron nozzle produced a force of 40 to 140 percent greater. Forces measured at all distances tested (0.9, 1.8, and 2.7 m or 3, 6, and 9 ft.) with the Akron nozzle showed little variation.

#### 4.5 Temperature on Wing Skin

Figure 3.3 shows the maximum wing skin temperature recorded as a function of nozzle distance from wing. For these trials, the angle of incidence was fixed at an angle perpendicular to the plate.

At 0.9 m (3 ft.) from the surface (typical operating distance) and with an OAT of 8°C, the surface temperature was raised to 20°C using forced air alone, and to 35°C with the air/fluid combination. These temperatures were only reached after directing the flow at a fixed point on the plate for some time.

The following discussion of tests measuring time until refreezing offers a more telling description of peak skin temperatures produced by the various deicing modes tested. The increase in skin temperatures resulting from forced air (and, to a lesser degree, from fluid injected air) was considerably reduced compared to that resulting from standard nozzle applications of heated fluid, and contributed to a reduced time interval until refreezing occurred.

It should be noted that the test wing was empty of fuel for these trials.

#### 4.6 Elapsed Time until Refreezing

##### 4.6.1 Removal of Ice

Table 4.1 presents data related to removing ice from the test wing in freezing rain. The thickness of ice over the wing surface was measured to be about 0.25 cm (0.1 in.). The freezing rain precipitation rate was about 15 g/dm<sup>2</sup>/h.

The forced air configuration was unable to break the bond between the layer of ice and the wing surface. The heat within the air stream was insufficient to melt through the ice.

FIGURE 4.4  
**FORCE ON A 25 in<sup>2</sup> DISC**  
**STD TYPE I DEICING, AKRON NOZZLE**  
FORCED AIR DEICING TRIALS – NRC CANADA CEF OTTAWA, APRIL 17-20, 2000

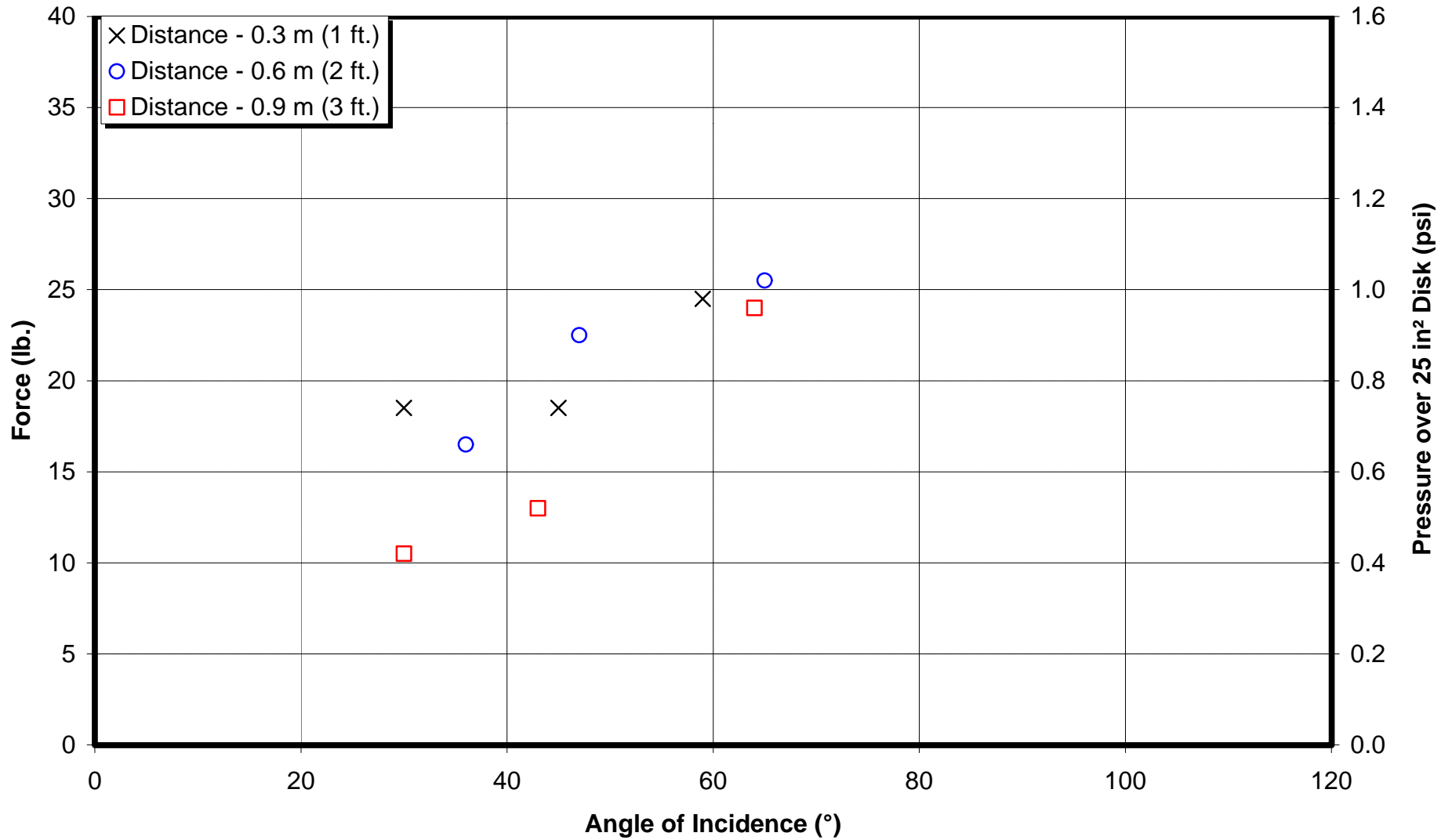

TABLE 4.1  
**REMOVAL OF ICE 0.25 cm (0.1") THICK**  
**AMBIENT TEMP. = -10°C, FREEZING RAIN @ ~15 g/dm<sup>2</sup>/h**

Test ID #	Deicing Mode	Fluid		Time to Deice (min)	Time to Refreeze (min)	Quiet Area (g/brix)	Comment
		Temp (°C)	Qty (L)				
1	Air		0				Unable to remove ice
3	Air/ Injected Fluid	60	174	7:23	3:52	LE Top=11 g @ 7 LE Cavity=11 g @ 20 <b>TOTAL=22 g</b>	Visibility OK - not greatly reduced due to vapour
2	Std Type I	60	250	3:11	8:22	LE Top=17 g @ 7 LE Cavity=25 g @ 20 <b>TOTAL=42 g</b>	Lost visibility @ 1 minute

The air/fluid combination did melt through the ice and was able to remove it from the wing. The time to clean the wing with this process was over 7 minutes. Time to refreeze was just under 4 minutes.

The standard fluid nozzle cleaned the wing in just over 3 minutes. At about one minute into the deicing process, deicing was temporarily halted due to the lack of visibility as a result of the vapour created when spraying heated Type I fluid into an OAT of -10 C. Visibility was regained by partially opening the chamber door. The cleaning time shown was thus extended by about ½ minute. Time to refreeze was 8 minutes.

The standard nozzle method used 250 L of fluid, whereas the air/fluid method used 174 L.

Figures 4.5 and 4.6 present the temperature profile of the wing surface as measured by the thermistor probes. These profiles offer an explanation for the much shorter time to refreeze demonstrated by the air/fluid combination as compared to the standard method of deicing (using the Akron nozzle). The heat transfer to the wing surface is seen to be much greater with the standard method of deicing, with peak temperatures in the order of 50°C as compared to 25°C for the air/fluid method. With the air/fluid method, the temperature at some locations barely rose above 0°C and almost immediately dropped below freezing. It is unknown whether the thickness of the fluid film resulting from the air/fluid method was similar to that of the standard spray, or whether the force of the air stream blew away any significant part of the fluid from the wing surface. Any further tests should attempt to determine the thickness, distribution, and condition of the Type I fluid on the wing.

Photo 4.1 shows ice refreezing on the wing surface.

#### 4.6.2 Removal of Dry Snow

Table 4.2 presents data related to removing dry snow from the test wing. Snow depth at test start was measured to be about 7.5 cm (3 in.). The snow precipitation rate was in the order of 10 to 15 g/dm<sup>2</sup>/h. Ambient temperature was -17°C.

Prior to starting these trials, tests were conducted to evaluate the effect of distance on the ability of the air blower to remove snow. Based on the results, it was agreed with industry test observers to operate with the nozzle at a distance of 0.9 m (3 ft.) from the surface.

**FIGURE 4.5**  
**WING SKIN TEMPERATURE PROFILES**  
**ID #2 – ICE 0.25 cm (0.1") THICK, STD TYPE I DEICING**  
 FORCED AIR DEICING TRIALS – NRC CANADA CEF OTTAWA, APRIL 17-20, 2000

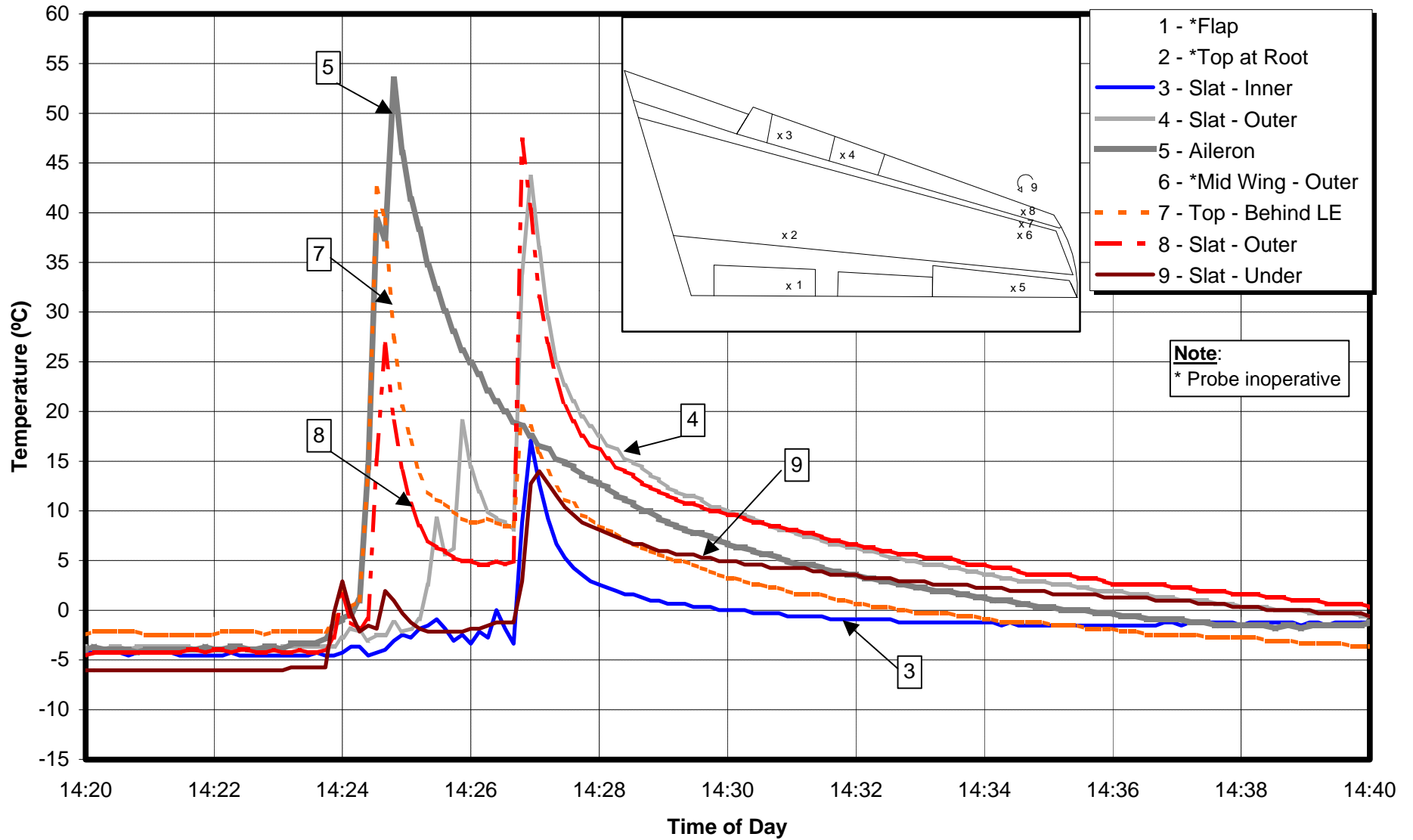

**FIGURE 4.6**  
**WING SKIN TEMPERATURE PROFILES**  
**ID #3 – ICE 0.25 cm (0.1") THICK, AIR/INJECTED TYPE I DEICING**  
**FORCED AIR DEICING TRIALS – NRC CANADA CEF OTTAWA, APRIL 17-20, 2000**

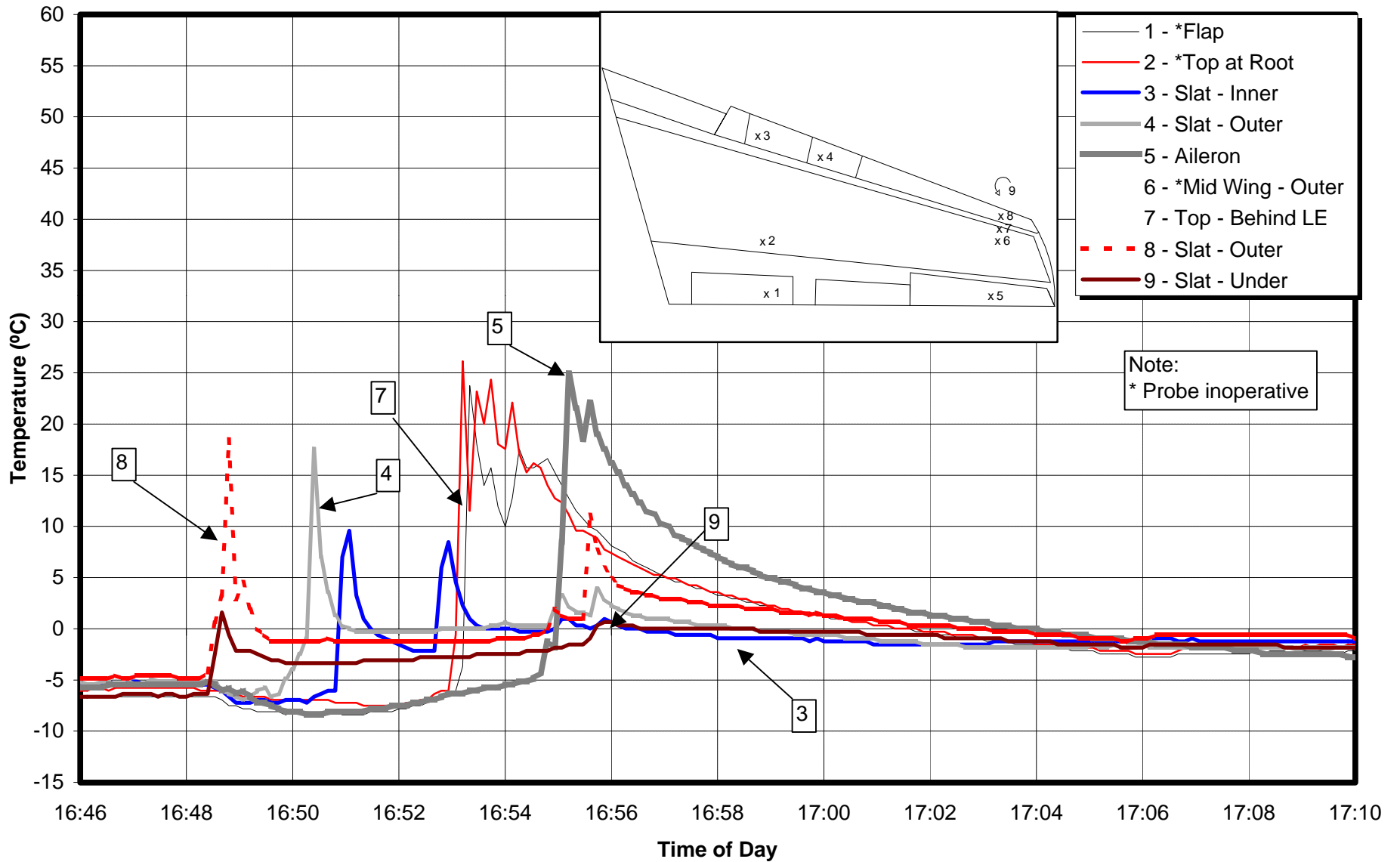

TABLE 4.2  
**REMOVAL OF DRY SNOW 6.4 cm (2.5") THICK**  
**AMBIENT TEMP. = -17°C**  
 NOZZLE DISTANCE AT >3 ft. FROM WING

Test ID #	Deicing Mode	Fluid		Time to Deice (min:sec)	Time to Refreeze (min:sec)	Quiet Area (g/brix)	Comment
		Temp (°C)	Qty (L)				
6	Air		0	2:06	0:00	no residue	Snow making halted during cleaning to examine visibility. Visibility OK. Film of snow over entire wing at end of cleaning, with adhered small clumps scattered here and there. Snow on LE.
4	Air/ Injected Fluid	71	44	2:17	<1:00	not checked	Complete film of snow over wing at one minute after deicing. Visible throughout.
5	Std Type I	70	214	2:57*	2:48	not checked	*Includes pause during spraying due to lack of visibility



The time taken to remove dry snow from the wing by the different methods showed less difference than that for the removal of ice. All cleaning times were from 2 to 3 minutes. Deicing was halted temporarily during the standard fluid application method to regain visibility while the chamber door was opened.

In tests removing snow with the air-only method, the artificial snowmaking was suspended to better assess any loss of visibility from blown snow. At the end of the cleaning activity, a fine film of snow remained over the entire wing. This film consisted of snow that had been blown into the air during snow removal and that had then fallen back onto the wing. As well, small clumps of snow were seen scattered across the wing surface. These clumps consisted of compacted snow adhered to the wing.

In the deicing process, the operator's bucket was located over the middle of the wing behind the leading edge. As a result, the air and fluid nozzles were directed at the leading edge from behind instead of from in front of the wing as in the standard procedure. For the forced air test, this resulted in a line of snow being left along the leading edge. This points out a significant difference between cleaning by forced air alone and the standard nozzle application of heated fluid. With the standard method, the heated fluid ran forward and removed the snow on the leading edge, even though that area was not subjected directly to the fluid application.

For forced air deicing, based on the existence of the fine film of snow over the entire wing at the end of the deicing activity, time to refreeze was considered to be zero. This observation is compatible with the measured wing skin temperatures.

Cleaning the wing with the air/fluid combination produced a clean wing at the end of the deicing activity. In this test, the artificial snowmaking continued during the cleaning process to enable examination of the time to refreeze. Refreezing occurred at less than one minute after deicing. The quantity of fluid applied was 44 L.

Cleaning the wing with the standard fluid nozzle produced a clean wing and a time to refreeze of 2 min 48 sec. The quantity of fluid applied was 214 L.

Figures 4.7 to 4.9 present the temperature profiles of the wing surface during and after snow removal by the different methods. These profiles offer an explanation for the differences in time-to-refreeze demonstrated by the different deicing methods.

**FIGURE 4.7**  
**WING SKIN TEMPERATURE PROFILES**  
**ID #6 – DRY SNOW 6.25 cm (2.5") THICK, AIR DEICING, OAT -18°C**  
**FORCED AIR DEICING TRIALS – APRIL 19, 2000**

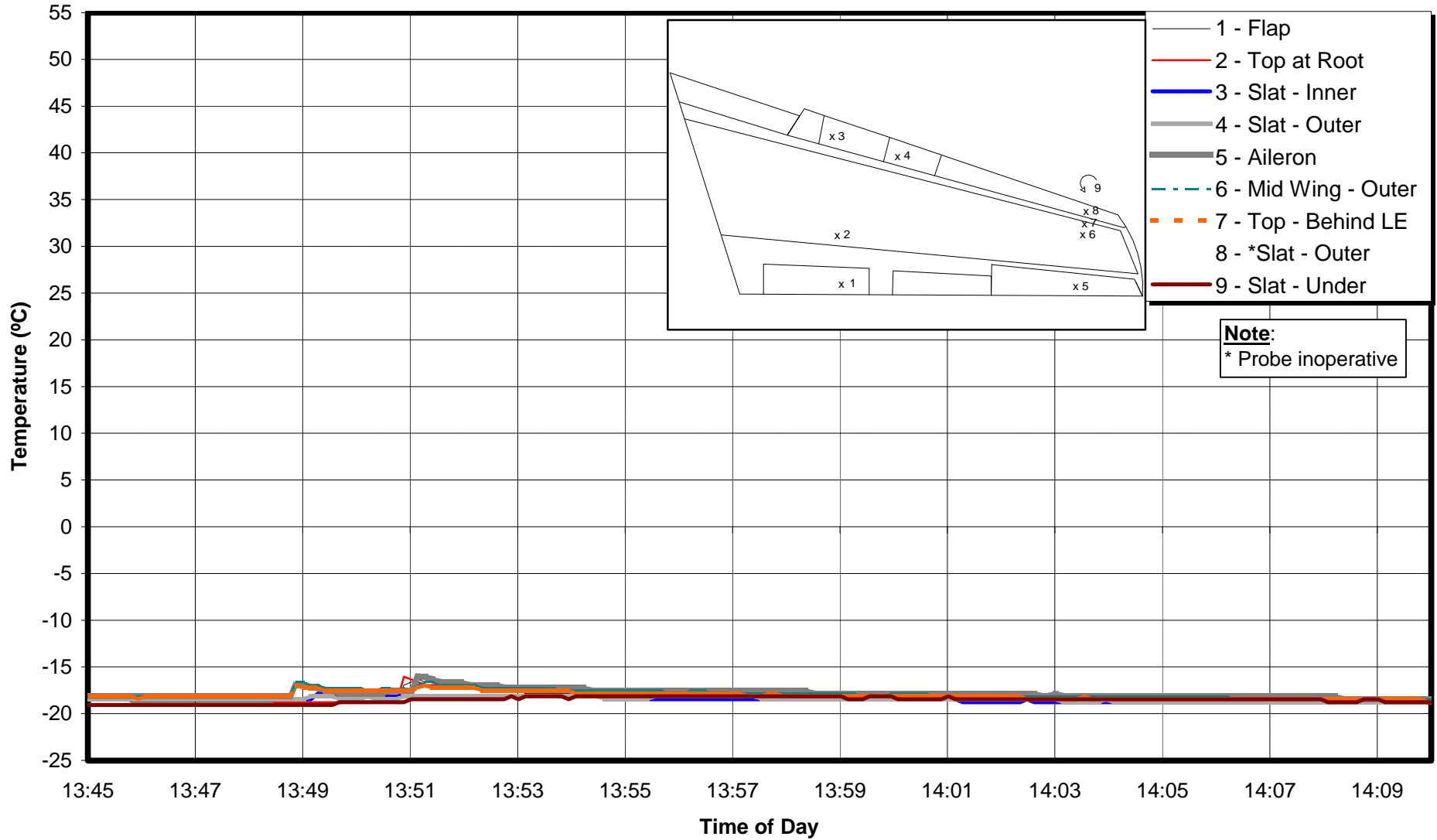
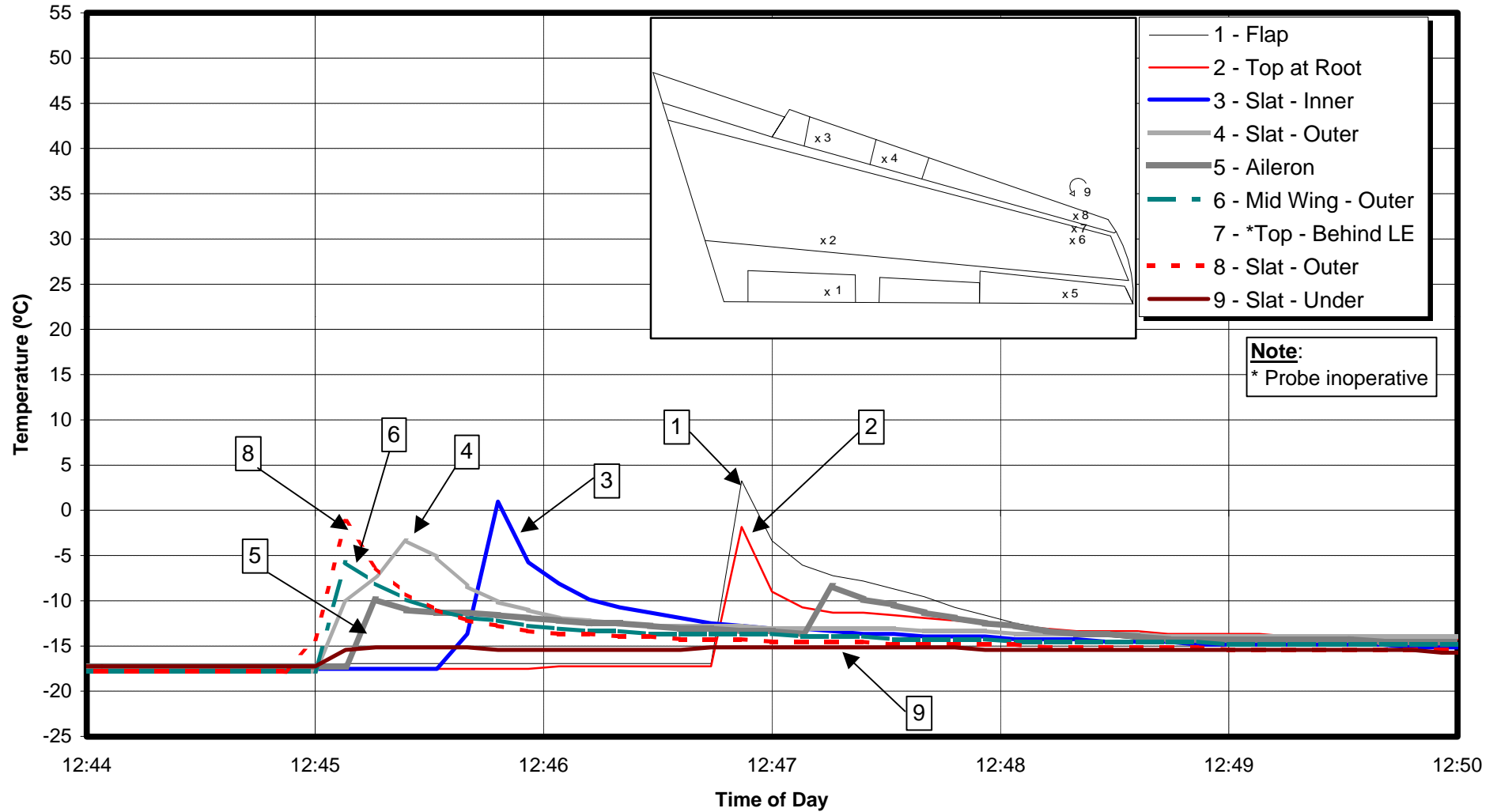
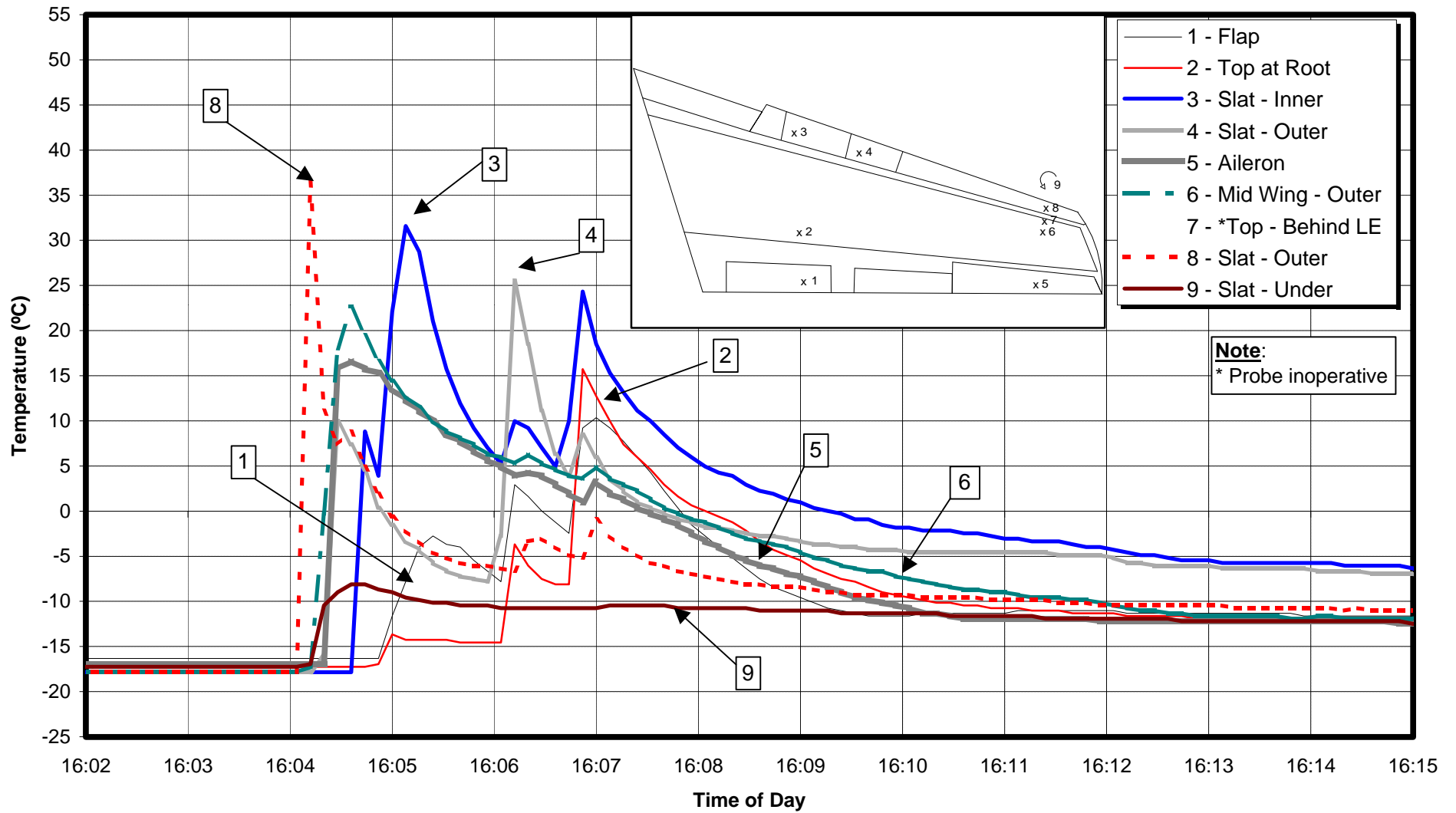

FIGURE 4.8  
**WING SKIN TEMPERATURE PROFILES**  
**ID #4 – DRY SNOW 6.25 cm (2.5") THICK,**  
**AIR/INJECTED TYPE I DEICING, OAT -18°C**  
 FORCED AIR DEICING TRIALS – APRIL 18, 2000



**FIGURE 4.9**  
**WING SKIN TEMPERATURE PROFILES**  
**ID #5 – DRY SNOW 6.25 cm (2.5") THICK,**  
**STD TYPE I DEICING, OAT -17°C**  
**FORCED AIR DEICING TRIALS – APRIL 18, 2000**



In the case of cleaning with forced air (Figure 4.7), very little heat was transferred to the wing surface and the skin temperature rose from  $-18^{\circ}\text{C}$  to only  $-16^{\circ}\text{C}$ . As there was no freeze-point depressant fluid present, and as the wing temperature was well below freezing, time-to-refreeze was zero.

Photo 4.2 shows the condition of the wing following cleaning by forced air.

In the case of cleaning with the air/fluid combination (Figure 4.8), a greater amount of heat was transferred, producing peak skin temperatures just above  $0^{\circ}\text{C}$ . These peak temperatures rapidly dropped below freezing and reached a stable level of  $-16^{\circ}\text{C}$  in about 1.5 minutes.

In the case of cleaning with the standard fluid application (Figure 4.9), sufficient heat was transferred to cause peak skin temperatures in the order of  $30^{\circ}\text{C}$ . Time taken to cool to ambient temperature was considerably longer than for the other methods, varying from 3 minutes to greater than 15 minutes for different points on the wing surface.

Because the strength of the fluid layer on the wing was not measured in these tests, a freeze-point profile is not available. Information on the thickness and rate of dilution of the fluid application for the different deicing methods would be useful in any future tests.

#### 4.6.3 Removal of Wet Snow

Table 4.3 presents data related to cleaning wet snow from the test wing. At the beginning of the test, snow depth was in the order of 5 to 10 cm (2 to 4 in.). The snow precipitation rate was in the order of 10 to 15 g/dm<sup>2</sup>/h. Ambient temperature was  $-5^{\circ}\text{C}$ .

As with the dry snow tests, the air nozzle was operated at a distance of 0.9 m (3 ft.) from the surface. The standard fluid nozzle was not tested in this session with wet snow.

A separate test was conducted to examine whether the forced air would push the wet snow along the wing surface, causing it to pile up (referred to as roll-up) to a point where the pressure exerted by the forced air could no longer move it. This test was conducted on the wing surface at the wing root, outside the designated test area. The roll-up condition did not occur; rather, the layer of snow was seen to erode from the top down under the applied air stream.

TABLE 4.3  
**REMOVAL OF WET SNOW 6.4 cm (2.5") THICK**  
**AMBIENT TEMP. = -15°C**  
 NOZZLE DISTANCE AT >3 ft. FROM WING

Test ID #	Deicing Mode	Fluid		Time to Deice (min)	Time to Refreeze (min)	Quiet Area (g/brix)	Comment
		Temp (°C)	Qty (L)				
7	Air		0	2:51	0		Snow making halted for deicing trial. At end of deicing, film of snow over entire wing, with scattered and adhered clumps of snow. Visibility not affected. Small clump of snow was lifted and fell off edge of wing.
7a	Air (supplemental test at wing root with wetter snow)						Forced air did not cause wet snow to roll up, but gradually eroded from top down.
8	Air/Injected Fluid	60	122	5:37	0:00	Small pieces of wetted snow slush in slat cavity & on exposed L.E	Snow film over entire wing in one minute after end of deicing . Visibility reduced.

In the wet snow removal tests, the time to clean the wing was considerably shorter for forced air alone than for the air/fluid combination (2 min 51 sec versus 5 min 37 sec).

As in the case of cleaning dry snow, the forced air alone left a film of snow over the entire wing surface at the end of the deicing activity.

Again, small clumps of adhered snow were scattered across the wing surface. Photo 4.3 shows the condition of the wing following cleaning by forced air.

The air/fluid combination produced a clean wing. Under the ongoing artificial snowfall, snow reappeared over the entire wing within one minute. The quantity of fluid applied was 122 L. As noted in the earlier discussion on visibility, the long deicing time in this test with the air/fluid combination also resulted in a reduced visibility condition.

Figure 4.10 shows the skin temperature profile resulting from the air/fluid method. The peaks are somewhat higher than those seen in the dry snow case, perhaps because of the increased quantity of fluid applied. Nevertheless, the temperature quickly cooled below 0°C, and most points stabilized at -12°C in less than one minute.

## 4.7 Residue in Quiet Areas

Residue was examined by lowering the leading edge slat, examining the exposed areas for residue, and wiping up any fluid for weighing. The area along the top of the wing that was exposed when the slat was dropped was referred to as the leading edge top, and related data were coded as LE Top. The cavity within the slat was referred to as the leading edge cavity, and related data were coded as LE Cavity. Data and comments are included in Tables 4.1, 4.2, and 4.3.

### 4.7.1 Ice Removal

Fluid residues following the standard nozzle deicing method and the air/fluid combination were very similar. The concentration of fluid residues found on the LE Top and LE Cavity were identical for the two methods. The quantity of fluid residue was higher for the standard method of deicing (42 g versus 22 g; Table 4.1) but neither method left a large quantity.

**FIGURE 4.10**  
**WING SKIN TEMPERATURE PROFILES**  
**ID #8 – WET SNOW 6.25 cm (2.5") THICK,**  
**AIR/INJECTED TYPE I DEICING, OAT -14°C**  
**FORCED AIR DEICING TRIALS – APRIL 20, 2000**

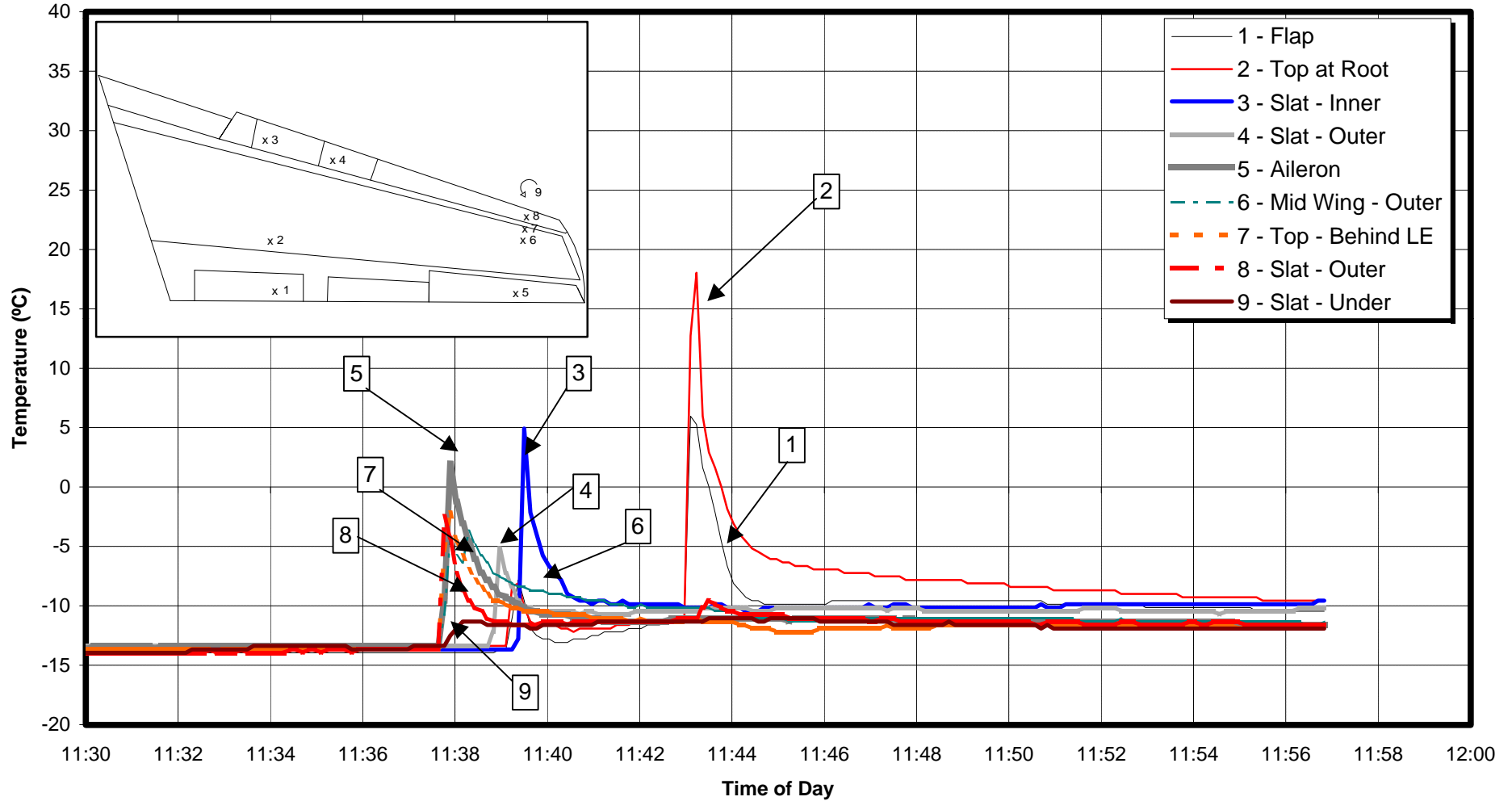



#### 4.7.2 Dry Snow Removal

The quiet area check was conducted only for the test using forced air alone to clean the wing. No residue was seen.

#### 4.7.3 Wet Snow Removal

The quiet area check was conducted for the test using the air/fluid combination. Small flat pieces of wet snow remained, both on the LE Top and LE Cavity. Photos 4.4 to 4.6 show the resulting condition. The wet snow was evidently forced under the trailing edge of the slat by the pressure of the combined air/fluid stream, thereby forming snow platelets having a depth equal to the gap between the slat and the wing.

The gap between the slat and the wing had been measured during a previous trial, and values are shown in Figure 4.11. Although these gaps may be considered large, they are probably representative of older aircraft in operational service.

### 4.8 Shearing of Type IV Fluids

Viscosity values for fluid samples applied by the various nozzles at varying distances are shown in Figure 3.8.

The horizontal line represents the specified viscosity for this fluid when tested for holdover times (HOT). The two samples taken from the truck tank correspond to the specified viscosity.

In the case of fluid injected into the air stream and applied at a 0.9 m (3 ft.) distance, the final viscosity was reduced from the initial value. In *all* other cases, the final viscosity was equal to or greater than the initial value. According to the manufacturer, an increase in viscosity as a result of spraying is characteristic of this fluid.

The viscosity measurements were conducted 8 days after the actual tests. During this interval, some viscosity recovery may have occurred. Furthermore, the fluid samples were centrifuged prior to testing to remove air bubbles that were still quite evident in the fluid. Consequently, the measured viscosity may not reflect the actual viscosity of the fluid on the wing immediately following application and during that period when holdover times normally apply. Any further tests should attempt to determine the viscosity and condition of the fluid at this critical phase.

FIGURE 4.11  
**WING/FLIGHT CONTROL SURFACE GAPS**  
 JETSTAR TEST WING

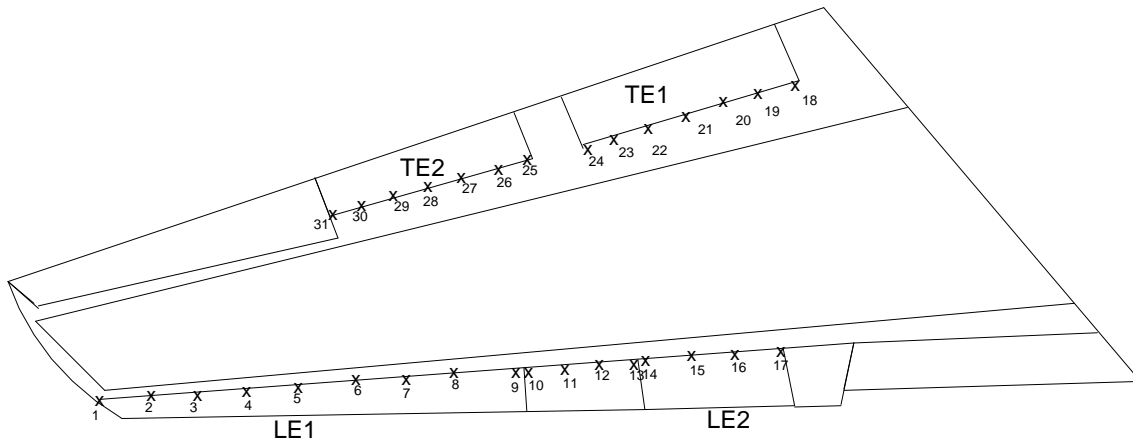

Measurements taken at 28 cm (11")

LE1		
Loc	Gap	
	(mm)	(in.)
1	1.75	0.069
2	2.24	0.088
3	1.75	0.069
4	1.75	0.069
5	2.29	0.09
6	1.19	0.047
7	1.75	0.069
8	0.61	0.024
9	1.19	0.047
10	1.75	0.069
11	1.75	0.069
12	1.75	0.069
13	0.61	0.024

LE2		
Loc	Gap	
	(mm)	(in.)
14	0.72	0.0285
15	< 0.38	< 0.015
16	1.19	0.047
17	0.61	0.024

TE2		
Loc	Gap	
	(mm)	(in.)
18	0.97	0.038
19	0.09	0.0035
20	3.73	0.147
21	2.29	0.09
22	1.75	0.069
23	1.19	0.047
24	< 0.04	< 0.0015

TE1		
Loc	Gap	
	(mm)	(in.)
25	1.75	0.069
26	< 0.04	< 0.0015
27	< 0.04	< 0.0015
28	0.09	0.0035
29	0.64	0.025
30	< 0.04	< 0.0015
31	< 0.04	< 0.0015

Photo 4.1  
Ice Reforming after Air/Injected Fluid Deicing

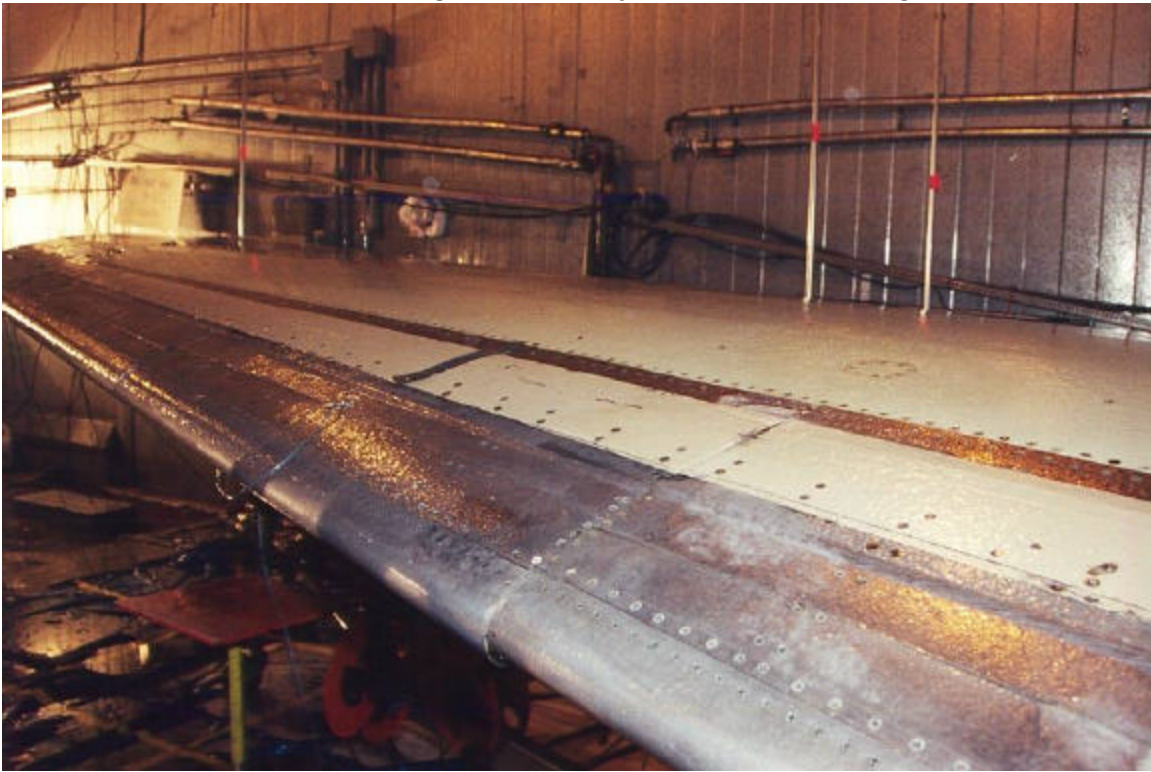

Photo 4.2  
Wing Condition Following Air Deicing of Dry Snow

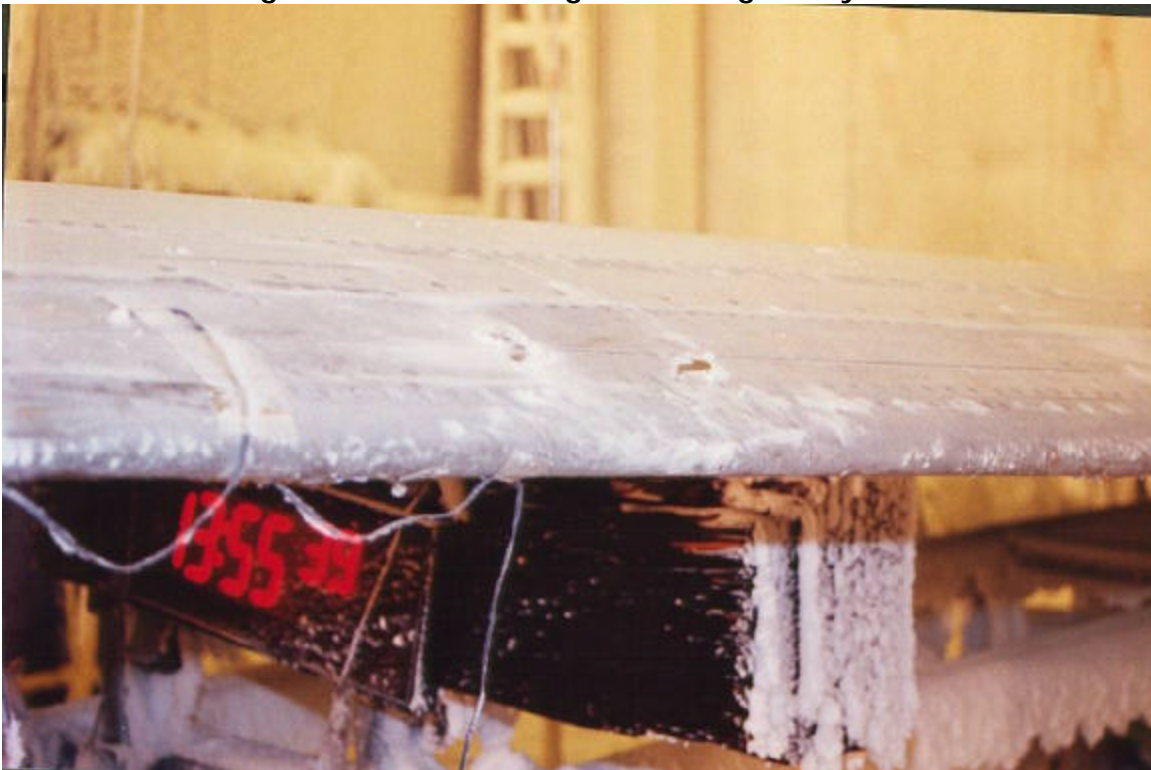

Photo 4.3  
Wing Condition Following Air Deicing of Wet Snow



Photo 4.4  
Wing Condition Following Air/Injected Fluid Deicing of Wet Snow



Photo 4.5  
Slush Residue on Exposed Leading Edge  
Following Air/Injected Fluid Deicing of Wet Snow



Photo 4.6  
Slush Residue in Leading Edge Slat Cavity  
Following Air/Injected Fluid Deicing of Wet Snow



## 5. CONCLUSIONS

### 5.1 Noise Levels

Measured noise levels were greater than the IATA AHM 910 standard of 85 dBA at 15 ft. from the vehicle perimeter. Noise levels at all locations, including the operator bucket, can be controlled to acceptable levels by wearing hearing protectors.

### 5.2 Effect on Visibility

The loss of visibility related to vapour generation from heated fluid was less for the air/fluid combination than for the standard nozzle method of fluid application.

Snow blown by the forced air stream did not cause any significant loss of visibility to the deicing operator in the bucket or to the vehicle driver.

### 5.3 Ice and Snow Projectiles

The forced air application was not able to remove the ice film.

Removal of the thin film of ice with the air/fluid combination resulted in small coin-sized pieces of ice being lifted from the wing and blown away to fall near the wing perimeter.

With the forced air application, snow was removed primarily by erosion, and the resulting separate snow crystals were blown away from the wing. Occasional clumps of snow were lifted and these fell near the wing perimeter.

Preformed pieces of ice placed on the wing surface were broken up by the force of the air stream and also by being lifted and then dropped back onto the wing. Some of the resulting small pieces were blown across the wing and then against the chamber door, about 3 m distant. They fell about 1 m (3.3 ft.) in transit. The average horizontal velocity was calculated to be about 7 m/sec (16 mph).

It is concluded that the forced air deicing system as tested presented no significant hazardous condition for ice and snow projectiles.

#### 5.4 Pressure on Wing Skin

The forced air application and the air/fluid combination produced similar pressure on the wing surface.

At a 0.9 m (3 ft.) distance and a 45° angle of incidence (typical of operations), the force over the sensor disc was 13 lb., equivalent to 0.5 psi. The maximum-recorded force (produced with a nozzle distance of 0.3 m (1 ft.) and a 90° angle of incidence) was 32 lb., or 1.3 psi.

Forces at a nozzle distance of 0.3 m (1 ft.) were about 40 percent greater than at 0.9 m (3 ft.).

The force exerted by the injected-fluid-only configuration was very low, with a maximum value of 5 lb. or 0.2 psi.

The force exerted by fluid delivered by the Akron nozzle at a distance of 0.9 m (3 ft.) was 40 to 140 percent greater than the air and air/fluid modes at the same distance.

Forces exerted by the Akron nozzle at all distances tested (0.9, 1.8, and 2.7 m or 3, 6, and 9 ft.) showed little variation.

It is concluded that forces exerted on the aircraft surface by the forced air deicing system as tested are acceptable. None of the forces measured on the 25 in<sup>2</sup> disc produced a pressure (force divided by disc area) greater than the Boeing maintenance manual, which indicates that no force greater than 10 psi may be allowed on a surface of 25 in<sup>2</sup>.

#### 5.5 Temperature on Wing Skin

At 0.9 m (3 ft.) from the surface (typical operating distance) and OAT of 8°C, the test plate temperature was raised to a peak of 20°C using forced air alone, and to 35°C with the air/fluid combination.

It is concluded that the temperature rise in aircraft surfaces subjected to the forced air deicing system as tested are less than experienced with standard heated fluid applications, and as a result are acceptable.

## 5.6 Elapsed Time until Refreezing

### 5.6.1 Removal of Ice

The air-only configuration was unable to break the bond between the layer of ice and the wing surface, as the heat transfer from the air stream was insufficient to melt through the ice.

The air/fluid combination did melt through the ice and cleaned the wing in just over 7 minutes. The time to refreeze was just under 4 minutes.

The standard fluid application cleaned the wing in just over 3 minutes. Time to refreeze was 8 minutes.

The heat transfer to the wing surface was much greater with the standard method of deicing, producing peak temperatures in the order of 50°C, as compared to 25°C for the air/fluid method. This is believed to be a major contributing factor to the longer time until refreezing with the standard method.

It is unknown whether the thickness of the fluid film resulting from the air/fluid method was similar to that of the standard spray, or if it was reduced by the force of the air stream blowing away some of the fluid. This should be examined in any future tests.

### 5.6.2 Removal of Dry Snow

For forced air deicing, time to refreeze was zero. Skin temperature rose from -18°C to only -16°C.

It is concluded that the use of forced air alone (with the equipment as tested) is not a feasible alternative for either the first step of a two-step deicing procedure or as a one-step procedure.

Cleaning the wing with the air/fluid combination produced a clean wing, but refreezing occurred in less than one minute after deicing. The quantity of fluid applied was 44 L. Peak skin temperatures just over 0°C rapidly dropped below freezing and stabilized at -16°C in about 1.5 minutes. The interval until refreezing occurred was considerably less than the typical 3-minute interval documented in SAE ARP4737. The reduction in time until refreezing must be at least partially due to the reduced heat transfer to the wing, but the thickness of the fluid film may be a second factor and should be investigated.



It is concluded that use of the air/fluid combination as tested is not a feasible alternative during snowfall or at cold OAT for either the first step of a two-step deicing procedure or as a one-step procedure.

Temperature profiles of the wing surface during and after snow removal partially explain the differences in time-to-refreeze.

Information on the thickness and rate of dilution of the fluid layer remaining on the wing following the different fluid application methods would further assist in the understanding of forced air deicing systems.

### 5.6.3 Removal of Wet Snow

The forced air application left a film of snow over the entire wing surface at the end of deicing. Small clumps of adhered snow were scattered across the wing surface. Time to refreeze was zero.

The air/fluid combination produced a clean wing but time to refreeze was less than one minute.

Results from testing with wet snow support the dry snow discussion and conclusions.

## 5.7 Residue in Quiet Areas

### 5.7.1 Ice Removal

Fluid residues following the standard nozzle deicing method and the air/fluid combination were very similar: fluid strength was identical and quantity of fluid residue was close (42 g versus 22 g; Table 4.1).

### 5.7.2 Dry Snow Removal

The quiet area check was conducted only for the test using forced air alone to clean the wing. No residue was seen.

### 5.7.3 Wet Snow Removal

The wet snow was forced under the slat trailing edge by the pressure of the combined air/fluid stream. This produced flat snow platelets having a depth equal to the gap between the slat and wing.

## 5.8 Shearing of Type IV Fluid

In the case of fluid injected into the air stream and applied at a 0.9 m (3 ft.) distance, the final viscosity was reduced from the initial value. In all other cases, the final viscosity was equal to or greater than the initial value.

Any further tests should attempt to determine the viscosity and condition of the fluid on the wing during the period when holdover times normally apply.

## 5.9 Appropriate Use of Forced Air in Deicing Operations

The examination of the effectiveness of the use of forced air (alone and with injected Type I fluid) in providing a clean surface and in producing an interval before refreezing adequate for application of an anti-icing fluid leads to certain conclusions regarding its suitability in performing specific deicing functions. Tables 5.1 to 5.4 present conclusions as to the appropriate use of forced air deicing. The tables address the use of forced air systems:

- to remove the bulk of contamination prior to deicing with heated fluid;
- as the first step of a two-step procedure followed by application of a cold anti-icing fluid;
- as a one-step procedure; and
- as a protective application prior to start of precipitation to prevent adherence.

It is emphasized that the conclusions presented in the tables are based on observations regarding the equipment as tested and may not apply to other equipment or to non-tested conditions.

Table 5.1  
**USE OF FORCED AIR TO REMOVE BULK OF CONTAMINATION PRIOR TO DEICING WITH HEATED FLUID**

	OAT -10°C		OAT -17°C		OAT -10°C		
	FROST	FREEZING FOG	SNOW		FREEZING DRIZZLE	FREEZING RAIN	RAIN ON COLD-SOAKED WING
			ADHERING	NOT ADHERING			
AIR	N <sup>1</sup>	N <sup>1</sup>	Y	Y	N <sup>1</sup>	N <sup>1</sup>	N <sup>1</sup>
AIR WITH INJECTED TYPE I	N <sup>2</sup>	N <sup>2</sup>	Y	Y	N <sup>2</sup>	N <sup>2</sup>	N <sup>2</sup>

Note 1: Air alone did not remove ice.

Note 2: As heat is needed to remove ice, the fastest method of transferring heat is by applying heated fluid with the standard fluid nozzle.

Table 5.2  
**USE OF FORCED AIR FOR THE FIRST STEP OF A TWO-STEP PROCEDURE,  
 FOLLOWED BY APPLICATION OF COLD ANTI-ICING FLUID**

	OAT -10°C		OAT -17°C		OAT -10°C		
	FROST	FREEZING FOG	SNOW		FREEZING DRIZZLE	FREEZING RAIN	RAIN ON COLD-SOAKED WING
			ADHERING	NOT ADHERING			
AIR	N	N	N <sup>3</sup>	N <sup>3</sup>	N	N	N
AIR WITH INJECTED TYPE I	Y	Y	N <sup>4</sup>	N <sup>4</sup>	Y	Y	Y

Note 3: A clean wing is not produced.

Note 4: Insufficient time prior to refreezing to apply over spray of anti-icing fluid.

Table 5.3  
**USE OF FORCED AIR AS A ONE-STEP PROCEDURE**

	OAT -10°C		OAT -17°C		OAT -10°C		
	FROST	FREEZING FOG	SNOW		FREEZING DRIZZLE	FREEZING RAIN	RAIN ON COLD-SOAKED WING
			ADHERING	NOT ADHERING			
AIR	N (NO HOT)	N (NO HOT)	N (NO HOT)	Y <sup>5</sup>	N (NO HOT)	N (NO HOT)	N (NO HOT)
AIR WITH INJECTED TYPE I	N (HOT NOT KNOWN)	N (HOT NOT KNOWN)	N (HOT NOT KNOWN)	N <sup>6</sup> (HOT NOT KNOWN)	N (HOT NOT KNOWN)	N (HOT NOT KNOWN)	N (HOT NOT KNOWN)

Note 5: A HOT is not needed, as snow is not adhering.

Note 6: Wetting of wing by injected fluid will cause adherence, thus a HOT is required.

Table 5.4  
**USE OF FORCED AIR AS A PROTECTIVE APPLICATION PRIOR TO START OF PRECIPITATION**

	OAT -10°C		OAT -17°C		OAT -10°C		
	FROST	FREEZING FOG	SNOW		FREEZING DRIZZLE	FREEZING RAIN	RAIN ON COLD-SOAKED WING
			ADHERING	NOT ADHERING			
AIR WITH INJECTED TYPE II OR IV	N (HOT NOT KNOWN) <sup>7</sup>	Y <sup>8</sup>	Y <sup>8</sup>	Y <sup>8</sup>	Y <sup>8</sup>	Y <sup>8</sup>	Y <sup>8</sup>

Note 7: For frost, this application is in reality a one-step procedure and thus requires a HOT.

Note 8: As this procedure is intended only to prevent adherence of contamination to the surface and includes a subsequent deicing treatment with heated fluid, the condition of the injected Type II or IV fluid after application is not critical.

*This page intentionally left blank.*

## 6. RECOMMENDATIONS

It is recommended that:

1. Other forced air deicing systems in current operational use be examined to determine whether they are an acceptable alternative for either the first step of a two-step deicing procedure or for the one-step procedure.
2. The thickness and rate of dilution of the Type I fluid layer remaining on the wing following application with a fluid/air combination nozzle be examined in conjunction with wing skin temperature decay profiles for each of the forced air deicing systems in current operational use.
3. The condition, thickness, and viscosity of Type IV fluid remaining on the wing during the period when holdover times normally apply (following application with a fluid/air combination nozzle) be examined for each of the forced air deicing systems in current operational use.
4. Test specifications be developed for evaluating the safety of forced air systems and the operational acceptability in performing either step of a two-step operation or a complete one-step deicing operation.

*This page intentionally left blank.*

## **APPENDIX A**

### **TERMS OF REFERENCE – PROJECT DESCRIPTION**



**PROJECT DESCRIPTION EXCERPT FROM  
TRANSPORTATION DEVELOPMENT CENTRE  
WORK STATEMENT**

**AIRCRAFT AND FLUID HOLDOVER TIME TESTS FOR WINTER 1999-2000  
(December 1999)**

**5.11 Forced Air System Evaluation**

The contractor shall co-ordinate tests to collect data for evaluating the safety of forced air systems. Tests will be performed as per SAE G-12 Equipment Sub-Committee Discussions which are in development. The tests will be performed in indoor-simulated conditions at the NRC. The Jetstar wing recently purchased will serve as an integral part of these tests. Tests will be designed to evaluate and document the safety and performance of the various forced air systems. Photo and video documentation will be recorded and will form part of a final report. Several of the proposed forced air systems will be subject to the same battery of experiments.

Different types of precipitation including dry/wet snow, freezing rain, frost and combinations of the aforementioned will then be allowed to accumulate on the aircraft surface.

The testing proposed will address safety issues of interest to the FAA and include issues related to Type IV fluid degradation caused by forced air injection, as identified in the recent Chicago trials. Those trials showed a variation of viscosity degradation, in some cases below that of the approved HOT table viscosity for the tested fluid.

The testing will also investigate the application of Type I/Forced Air in a one-step operation. This testing would evaluate the potential safety hazard caused by the imminent reduction of HOT due to the reduced heat sink or the lower quantities of glycol being used in this forced air method. Simultaneously, there is a need to evaluate the capability on these new systems to comply with the current three-minute safety period required in a two-step application.

Furthermore, much of the testing will surely result in the development of improved standards (for SAE ARP4737) on forced air vehicles for deicing.

Pressure and temperature sensors will be installed on the wing surface to evaluate the effects of the forced air on the aircraft surface. Precipitation accumulation and adhesion will be recorded so that the conditions are reproducible and consistent for all tests. Twelve days of chamber time have been scheduled. The wing surface will be inspected after each cleaning to evaluate cleanliness, damage, quiet areas, and precipitation/water residue. Decibel sound levels and contamination projectiles will be evaluated to confirm that they are within current safety guidelines.

**APPENDIX B**

**EXPERIMENTAL PROGRAM  
FORCED AIR DEICING SAFETY TRAILS**

**EXPERIMENTAL PROGRAM**  
**FORCED AIR DEICING SAFETY TRIALS**  
Winter 1999/2000  
Version 2.0

APS will co-ordinate a series of tests to evaluate safety of forced air systems. The safety issues examined will encompass potential for injury to personnel, potential for damage to aircraft, and ability to provide a clean wing for the interval until an anti-icing treatment is applied.

## **1. OBJECTIVES**

The elements to be examined in these trials include:

- The noise intensity generated by the forced air equipment. Noise will be measured in the cab of the deicing vehicle and at various locations around the vehicle.
- The effect on visibility when removing snow and ice. This will be evaluated from the perspective of the deicing vehicle driver, the deicing operator in the bucket, and ramp personnel.
- The tendency of the forced air deicing system to dislodge chunks of snow or ice and to fling them some distance and height. Associated risks include damage to aircraft, which could include engine ingestion and blowing contaminants from the top of the fuselage onto the wing, and potential injury to personnel working around the aircraft.
- The pressure exerted by the air stream on the skin of the aircraft.
- Residue in quiet areas. Any fluid or frozen contaminant residue in quiet areas at the flap, aileron, and leading edge slat will be quantified and documented following the forced air deicing.
- The elapsed time during ongoing precipitation following deicing, before refreezing or recontamination occurs on the wing. In the standard deicing procedures using heated fluid, the anti-icing protection is to be applied before the first-step fluid freezes, typically within three minutes.
- Shearing of Type IV fluid. Because it has been suggested that Type IV fluid could be injected into the air stream for certain applications, the shearing effect on Type IV fluid will be measured.

This series of trials will incorporate a control test using heated fluid applied by a trained operator following standard deicing procedures.

## 2. TEST REQUIREMENTS

APS will co-ordinate and plan test activities, prepare a final report, and present results at industry meetings.

A test plan and schedule of tests are included as Tables B-1 and B-2.

Tests will be conducted at the National Research Council Canada (NRC) Climatic Engineering Facility (CEF) at Ottawa International Airport.

Video and photography will document all events.

## 3. EQUIPMENT

Equipment to be employed is shown in Attachment I.

A Vestergaard Elephant  $\mu$  deicing vehicle equipped with a forced air system will be used for the trials.

## 4. FLUIDS

UCAR ADF Type I fluid will be used for these tests, both for the control test and as fluid injected into the air stream from the forced air nozzle.

UCAR AAF Type IV fluid injected into the air stream will be used for shear tests.

## 5. PERSONNEL

APS personnel will co-ordinate the forced air tests. A detailed description of the responsibilities is provided in Attachment II.

The forced air system will be operated by staff from AéroMag 2000 and from Vestergaard.

## 6. SUMMARY OF PROCEDURE AND MEASUREMENTS

### *Noise Intensity Generated by the Forced Air Equipment*

A noise sensor equipped with logging capability will be used to measure noise intensity. Intensity will be measured on the "A" scale to conform to known

regulations for acceptable levels of noise in the workplace.

Measures will be conducted outdoors with the deicing vehicle positioned at two locations: one being away from any buildings or structures that could affect the noise levels measured, and the second being adjacent to a building wall.

Noise measures will be taken in the vehicle cab and at several locations around the vehicle. One of these will reflect the IATA standard definition for noise limits from ramp vehicles (IATA AHM 910: a distance of 4.6 m (15 ft.) from the perimeter of the vehicle and at 1.5 m (5 ft.) above the ground).

### ***Effect on visibility when Removing Snow and Ice***

Effect on visibility will be documented by the use of video cameras and reflective markers positioned at known distances about the wing.

A video camera will be mounted at the deicing bucket in such a manner as to film the wing area being deiced with the air stream. The intent is to capture any effect on visibility experienced by the deicing operator.

A second video camera with an operator will be located in the cab of the deicing vehicle. The intent is to capture any effect on visibility experienced by the deicing vehicle driver.

Two video cameras will be mounted on tripods at ground level, with angles of view at 90° to each other, to provide two perspectives of the deicing process.

### ***Ice and Snow Projectiles***

A tarpaulin with a grid composed of one-metre squares will be placed on the ground under the wing, extending beyond the rear of the wing in the direction of the air stream. The distribution of chunks of ice and snow will be videotaped and recorded on a data form with a corresponding grid. Typical and larger chunks will be measured and weighed, and their final location noted using the grid pattern.

A second grid will be situated on the far wall of the cold chamber, also in the direction of the air stream. The two video cameras mounted on tripods at ground level, with angles of view at 90° to each other, will record the trajectories of any chunks of contaminant dislodged and flung from the wing surface. The vertical grid will provide a scale to quantify the nature of the trajectories.

### ***Air Stream Pressure on Wing Skin***

A pressure sensor composed of a load cell and a surrounding platform with an aperture of 25 in<sup>2</sup> will be used to measure the force exerted by the air stream on the wing skin. Tests will vary the angle of incidence of the stream and the distance from air jet to nozzle. These tests will measure all deicing modes: pure forced air, forced air with fluid injected, and sprayed fluid.

### ***Residue in Quiet Areas***

Following each deicing trial, the flap, leading edge slat, and aileron flight control surfaces will be lowered to enable evaluation of any fluid or solid contaminant remaining in the quiet areas. Any residue will be collected by use of pre-weighed wiping cloths, which then will be re-weighed to determine residue quantities. Brix values will be recorded for fluid residues recovered from quiet areas.

### ***Elapsed Time until Refreezing***

Test precipitation will be continued both during and after the deicing process. Observers will monitor the wing following deicing to record the time of refreezing, or when snow again appears on the surface.

An array of thermistor probes will be mounted at defined locations on the wing surface to measure and log the temperature profile of the wing skin during and after the deicing application.

### ***Shearing of Type IV Fluid***

Type IV fluid will be injected into the forced air stream, which will be directed onto the surface of a wing test section. Samples of the applied fluid will be collected and labeled for later analysis of viscosity.

### ***Precipitation Rate and Snow Density***

Rates of precipitation will be measured both for snowfall and freezing rain, following the standard procedure used in fluid holdover time trials. Pre-weighed rate pans will be positioned at defined positions around the wing perimeter. Accumulated precipitation will be weighed and exposure time recorded. Depth of snow will be recorded to calculate snow density.

## **7. DATA FORMS**

The data forms are listed below:

- Figure B-1                      General Form (Every Test)

- Figure B-2 Thermistor Probes Mounting Locations
- Figure B-3 Icing Form for Jetstar Wing
- Figure B-4 Residue in Quiet Areas
- Figures B-5 & B-5a Projectile Distribution
- Figure B-6 Precipitation Rate/Snow Density Measurement
- Figure B-7 Pressure Test
- Figure B-8 Measure of Noise Level

## 8. ROLES OF PARTICIPATING AGENCIES

**APS:** Co-ordinate and conduct tests.

**TDC/FAA:** Provide guidance and partial funding, and support the conduct of testing.

**G. Vestergaard A/S** Provide and install an air blower system on an Elephant  $\mu$  deicing vehicle. Provide instructions on its use. Provide equipment and operational support during the trials.

**AéroMag 2000** Provide an Elephant  $\mu$  deicing vehicle for installation of the air blower system. Transport the vehicle to the NRC Canada facility at Ottawa International Airport. Operate the vehicle and perform deicing together with the Vestergaard representative.

**Hudson General** Provide recovery and disposal of spent fluid.



TABLE B-1  
**FORCED AIR DEICING TRIALS – TEST PLAN**  
**NRC CANADA, OTTAWA, APRIL 17 - 20, 2000**

RUN	OAT (°C)	CONTAMINATION CONDITION	ACCUMULATION THICKNESS	DEICING MODE	PURPOSE OF TEST
1	-10	ZR (25 g/dm <sup>2</sup> /h)	0.25 cm (0.1")	Standard Type I fluid spray	Examine ice projectiles, elapsed time before refreezing, visibility, and residue in quiet areas
2	-10	ZR (25 g/dm <sup>2</sup> /h)	0.25 cm (0.1")	Air	
3	-10	ZR (25 g/dm <sup>2</sup> /h)	0.25 cm (0.1")	Air/injected Type I fluid	
4	-10	ZR (25 g/dm <sup>2</sup> /h)	0.5 cm (0.2")	Air/injected Type I fluid	
5	-10	Dry snow	4 cm (1.6")	Air	
6	-10	Wet snow	4 cm (1.6")	Air/injected Type I fluid	
7	-10	Wet snow	5 cm (1.6")	Air	
8	-10	Dry snow	8 cm (3.2")	Air	
9	-10	N/A	N/A	Standard Type I fluid spray	Pressure on wing skin
10	-10	N/A	N/A	Air	
11	-10	N/A	N/A	Air/injected Type I fluid	
12	-10	Dry	N/A	Air/injected Type IV fluid	Shearing of Type IV fluid
13	-10	Dry	N/A	Standard Type IV fluid spray	
14	N/A	N/A	N/A	Air	Measure noise levels

TABLE B-2  
**FORCED AIR DEICING TRIALS – TEST SCHEDULE**  
**NRC CANADA, OTTAWA, APRIL 17 - 20, 2000**

	<b>Monday April 17, 2000</b>	<b>Tuesday April 18, 2000</b>	<b>Wednesday April 19, 2000</b>	<b>Thursday April 20, 2000</b>
8:00	Set up	Make dry snow 8 cm (3.2") Noise test 14	Make dry snow 4 cm (1.6") Shear test 12	Make wet snow 4 cm (1.6")
8:30				
9:00				
9:30				
10:00				
10:30	Build up ice 0.25 cm (0.1")	Snow test 8	Snow test 5	Snow test 7
11:00				
11:30				
12:00	Ice test 1	Build up ice 0.25 cm (0.1")	Make wet snow 4 cm (1.6") Shear test 13	Tear down
12:30				
13:00	Build up ice 0.5 cm (0.2") Pressure tests 9 to 11	Build up ice 0.25 cm (0.1")	Snow test 6	
13:30				
14:00				
14:30				
15:00				
15:30	Ice test 4	Ice test 3		
16:00				
16:30	Close	Close	Close	
17:00				

Note 1: Schedule for Pressure tests and Noise tests may be changed to conduct these during periods of snow or ice build up, if possible.

Note 2: All tests in lab performed at -10°C

## ATTACHMENT I EQUIPMENT LIST

Forced Air Equipment List, April 17-20, 2000	Bring	Leave	Bring
JetStar wing			
Green tarps to cover wing			
Isopropyl alcohol to clean wing			
Big squeegee			
Small squeegee			
Scrapers			
Broom squeegee to clean wing			
Speed tape (thermistor installation)			
Thermistor equipment (2 loggers, 21 thermistors, 1 patch box, 2 relay cables (yellow/blue)			
Heat gun X 1			
Laptop IBM (with all software installed)			
Weigh scale (sortorious)			
Rags X 2			
Blue paper towels X 6			
Red buckets X 5			
Big/small measuring tape			
Still camera			
Video cameras, digital, surf & snow			
Big clock X 2			
Small clock X 1			
Viscosity sample jars 50 mL and 500 mL			
Markers to label sample jars			
Procedures / data forms			
Shop Vac			
Protective clothing			
Tripod lights X 3			
A/C extension chords			
Power bars			
White rate pans X 5			
Clipboards/pencils/pens			
Brixometers X 2			
Wahl hand-held temp probe			
Barnant hand-held temp probe			
Tie wraps			
Funnels			
Metal ruler for snow thickness			
Thickness gauges			
Spray paint			
Inclinometer yellow X 1			
Precipitation recipe sheet			
Rubber gloves/ white gloves-----BUY			
Hearing protectors			
Viscosity unit			
RH meter			
Centrifuge			
Plate on legs for HOT			

FIGURE B-1  
**GENERAL FORM (EVERY TEST)**  
**FORCED AIR DEICING TRIALS**

Date: \_\_\_\_\_

Aircraft Type: **JetStar Wing**

Run #: \_\_\_\_\_

DRAW DIRECTION OF TRUCK WRT WING:

Type of Application     AIR  
                                    AIR/INJECTED FLUID  
                                    FLUID

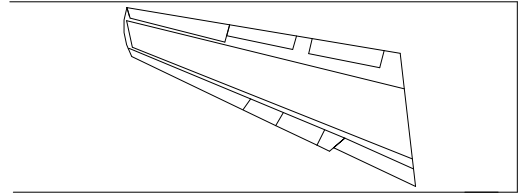

Truck #: \_\_\_\_\_

Distance from Nozzle to Wing \_\_\_\_\_ m

Type I Fluid Nozzle Type: \_\_\_\_\_

Angle of Jet Blast  
 relative to Horizontal: \_\_\_\_\_ °

<i>PRECIPITATION</i>	
Actual Start Time: _____ hh:mm:ss	Actual End Time: _____ hh:mm:ss
Start Temperature _____ °C	End Temperature: _____ °C

<i>DEICING APPLICATION</i>	
Actual Start Time: _____ hh:mm:ss	Actual End Time: _____ hh:mm:ss
Amount of Fluid Sprayed: _____ L / gal	Type of Fluid: _____
Fluid Temperature: _____ °C	Tank: _____ °C
Fluid Brix: _____	Nozzle: _____ °C

COMMENTS: \_\_\_\_\_  
 \_\_\_\_\_  
 \_\_\_\_\_  
 \_\_\_\_\_  
 \_\_\_\_\_

MEASUREMENTS BY: \_\_\_\_\_  
 HANDWRITTEN BY: \_\_\_\_\_

FIGURE B-2  
THERMISTOR PROBES MOUNTING LOCATIONS  
FORCED AIR DEICING TRIALS

---

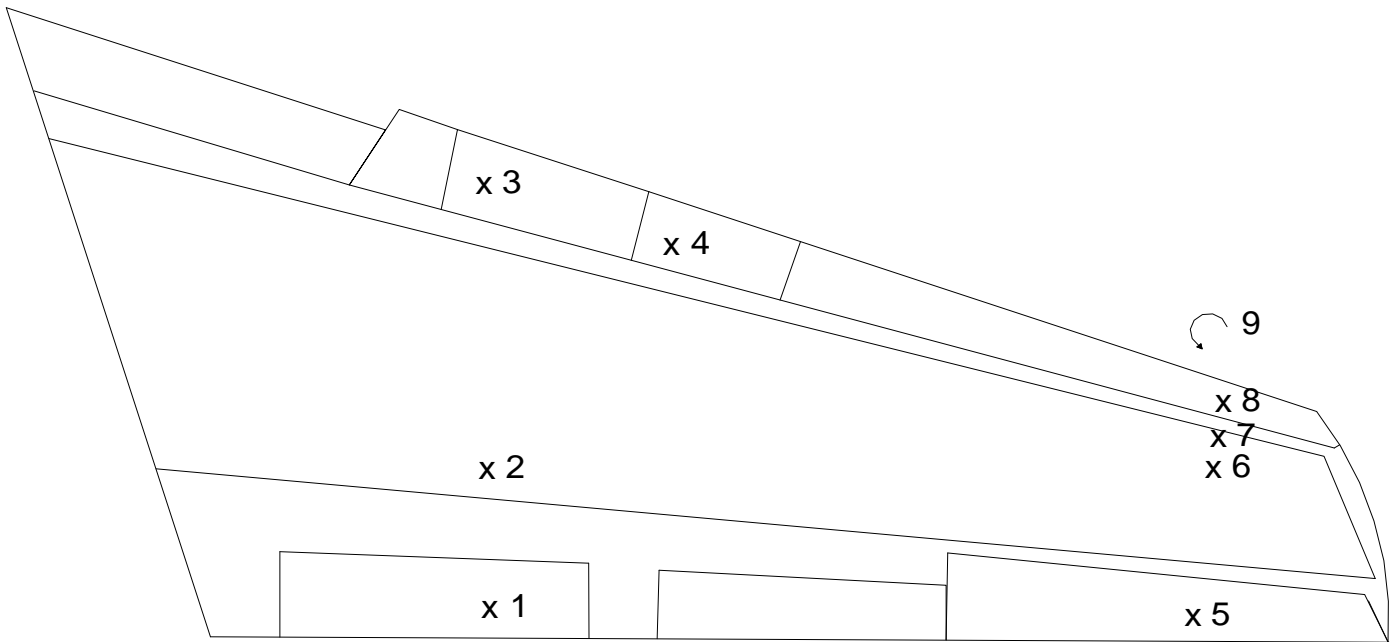

1. Mid-way forward, 1/3 distance from inner end
2. 6" forward from edge of main wing, in chord with # 1
3. Mid-way on LE, in chord with # 1
4. Mid-way chordwise and laterally on surface
5. Mid-way chordwise, 1/3 distance from outer end
6. 12" back from edge of main wing, in chord with # 5
7. 6" back from edge of main wing, in chord with # 5
- 8,9 1/2 way on LE, in chord with # 5

FIGURE B-3  
**ICING FORM FOR JETSTAR WING**  
**FORCED AIR DEICING TRIALS**

DATE: \_\_\_\_\_

RUN #: \_\_\_\_\_

**RECORDING INFORMATION:**

- **At time of 1st freezing:** - Note location and time on wing form. Advise other team members.
- **5 minutes after 1st freezing:** - Record patterns of ice on the wing form.  
 - Measure and record ice thickness and roughness.
- **Wing Cavity Inspection:** - Record appearance of any ice formation. Use additional forms as needed.

Initial Snow/Ice Depth	
Location	Depth

Refrozen Snow/Ice Patches	
Location	Thickness

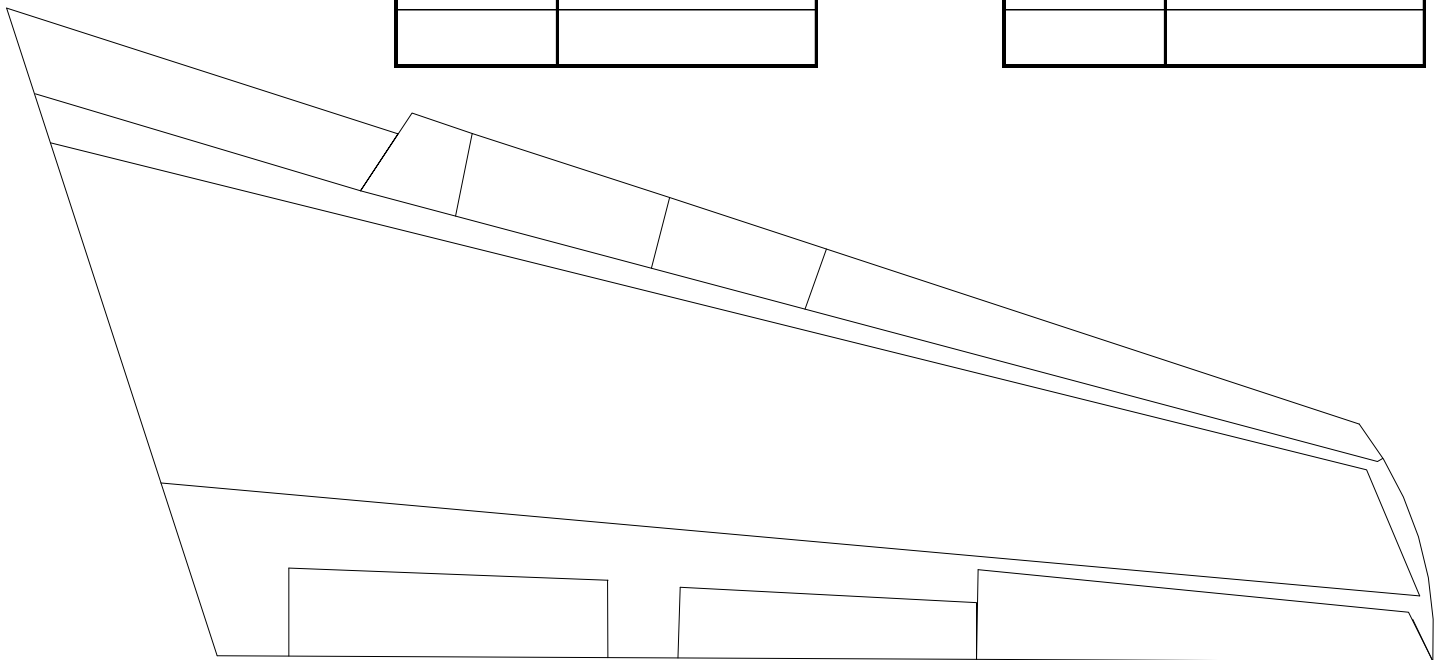

COMMENTS: \_\_\_\_\_

ICING RECORD BY: \_\_\_\_\_

\_\_\_\_\_

HANDWRITTEN BY: \_\_\_\_\_

\_\_\_\_\_

FIGURE B-4  
**QUIET AREA – RESIDUAL WATER ACCUMULATION TEST**  
 FORCED AIR DEICING TRIALS

Date: \_\_\_\_\_

Type of Precipitation: \_\_\_\_\_

Run #: \_\_\_\_\_

OAT: \_\_\_\_\_ °C

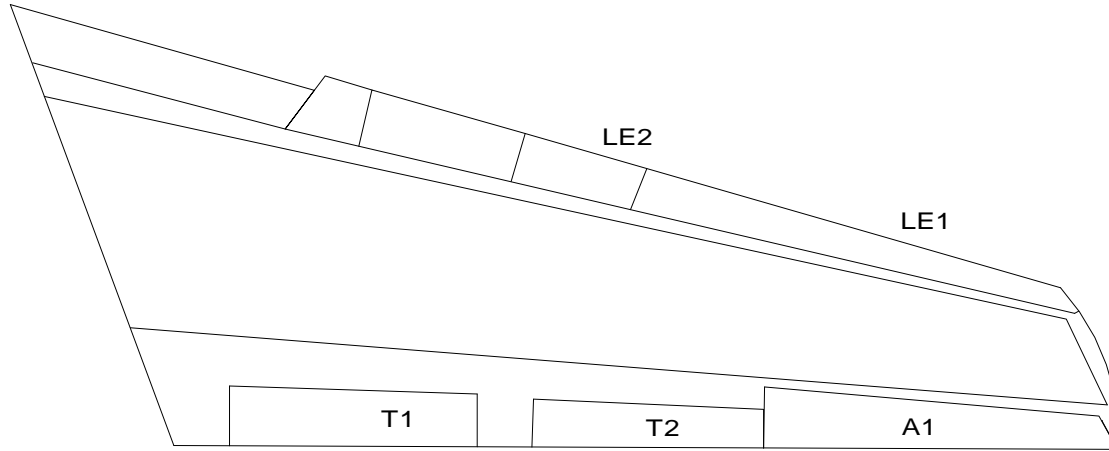

Tester	Location	Bucket Weight Before	Bucket Weight After	BRIX
	LE1 Top			
	LE1 Bottom			
	LE2 Top			
	LE3 Bottom			
	T1			
	T1			
	A1			

Comments: \_\_\_\_\_

\_\_\_\_\_

Recorded by: \_\_\_\_\_



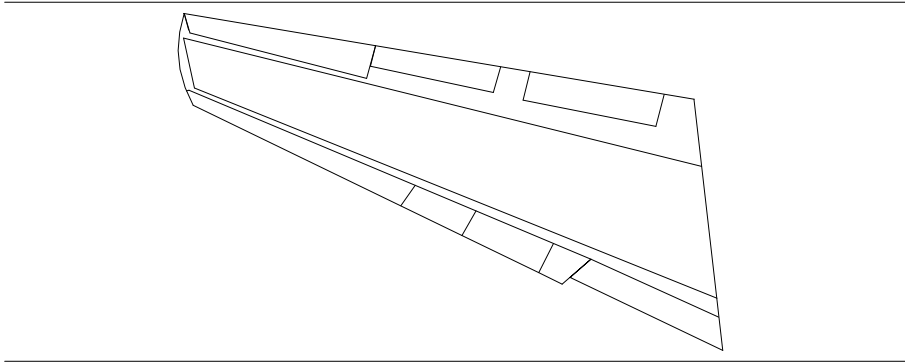



FIGURE B-6  
**PRECIPITATION RATE/SNOW DENSITY MEASUREMENT AT CEF IN OTTAWA  
 FORCED AIR DEICING TRIALS**

Date: \_\_\_\_\_ Needles used: \_\_\_\_\_  
 Start Time: \_\_\_\_\_ Flow Rate of Water: \_\_\_\_\_  
 Run # : \_\_\_\_\_ Line Air Pressure: \_\_\_\_\_  
 Precip Type: Snow / ZR- Line Air Temperature: \_\_\_\_\_  
 Line Water Pressure: \_\_\_\_\_  
 Line Water Temperature: \_\_\_\_\_

**Pan Location:**



**Collection Pan:**

<u>Pan #</u>	<u>Area of Pan (dm<sup>2</sup>)</u>	<u>Weight of Pan (g)</u>		<u>Depth of Snow (cm)</u>	<u>Collection Time (hr:mm:ss)</u>		<u>Rate</u>
		<u>Before</u>	<u>After</u>		<u>Start</u>	<u>End</u>	
_____	14.90	_____	_____	_____	_____	_____	_____
_____	14.90	_____	_____	_____	_____	_____	_____
_____	14.90	_____	_____	_____	_____	_____	_____
_____	14.90	_____	_____	_____	_____	_____	_____
_____	14.90	_____	_____	_____	_____	_____	_____
_____	14.90	_____	_____	_____	_____	_____	_____

**Comments:** \_\_\_\_\_  
 \_\_\_\_\_  
 \_\_\_\_\_  
 \_\_\_\_\_

**Handwritten by:** \_\_\_\_\_  
**Measured by:** \_\_\_\_\_



FIGURE B-8  
**MEASURE OF NOISE LEVEL**  
**FORCED AIR DEICING TRIALS**

Run #	Location of Nose Sensor relative to Deicing Vehicle and Air Nozzle (Sketch setup if helpful)	Horizontal Distance from Air Nozzle (m)	Sensor Height above Ramp (m)	Noise Level (dB on A scale)

**APPENDIX C**

**FORCED AIR DEICING TRIALS  
APRIL 2000  
LIST OF VISITING OBSERVERS**

**FORCED AIR DEICING TRIALS  
APRIL 2000  
LIST OF VISITING OBSERVERS**

<b>NAME</b>	<b>COMPANY</b>	<b>EMAIL</b>
Elo Svanebjerg	G. Vestergaard A/S	develop@g-vestergaard.dk
Anders Larsen	G. Vestergaard A/S	anders@g-vestergaard.dk
Wade Heisler	G. Vestergaard America	deicer@imaxx.net
Jerry Gorham	United Airlines	gerald.gorham@ual.com
Michel Ouellette	AéroMag 2000	
Mario Rosa	AéroMag 2000	m.rosa@aeromag.qc.ca
Pierre Lespérance	AéroMag 2000	aeromag@mmic.net
Edward Sachs	FMC	ed_sachs@fmc.com
Brock Crocker	United Airlines	brock.r.crocker@ual.com
Ian Sharkey	Radiant Energy Corp	isharkey@radiantenergycorp.com
Carl W. Blumenstein	NWA	cwblume@nwa.com; cwblume@charter.net
Nick Maramieri	Hudson General	nmaramieri@istar.ca
Tom Polka	Global	tpolka@global-llc.com
Mario Lepine	AéroMag 2000	aeromag@mmic.net
Frank Eyre	Transport Canada	eyref@tc.gc.ca
David Thornton	Delta Air Lines	david.thornton@delta-air.com
Paul Boris	Federal Aviation Administration	paul.boris@faa.gov

*This page intentionally left blank.*

**APPENDIX D**

**TEST DATA FROM TRIALS CONDUCTED AT  
CHICAGO AIRPORT  
NOVEMBER 1999**

**Sources: United Airlines, Chicago International Airport**



<b>Date</b>	November 17, 1999
<b>Location</b>	Chicago, AA and UA ground equipment maintenance facilities
<b>Time</b>	2200 – 0300
<b>Equipment Tested</b>	Global AirPlus FMC Premier Hybrid Vestergaard Beta
<b>Testing Accomplished</b>	
<b>Deicing</b>	Fluid temperature at incremental distances Fluid velocity at incremental distances Fluid glycol concentration after application Fluid coverage on representative surfaces
<b>Anti-icing</b>	Fluid coverage on representative surfaces Fluid thickness after application Fluid viscosity after application

# Weather

<i>TIME</i>	<i>TEMP F</i>	<i>REL HUM</i>	<i>WIND SPEED</i>	<i>BAR PRESS</i>
2200	45	43	9MPH	30.02
2300	44	45	10	30.00
0000	45	45	10	29.99
0100	47	45	9	29.97
0200	47	45	10	29.96

# Air Velocity Test

## Process

Apply forced air to a portion of B 727 wing (supplied by AA) at incremental nozzle distances: beginning at 14 ft. The air nozzle was set at about a 45 deg angle to the wing. An anemometer (Dwyer series 470) mounted flush to the surface measured air velocity parallel to the surface at a reference point located 3 ft. away from the projected jet impact point. The nozzle distance at which air velocity at reference point reaches about 6000 fpm was recorded.

# Air Speed

D	1 ft.	2 ft.	3 ft	4 ft.	5 ft.	6 ft.	7 ft.	8 ft.	9 ft.	10 ft.	11 ft.	12 ft.	13 ft.	14 ft.
<b>FMC [*1]</b>				off	5000	1800 fanned	1000 fanned	1700 fanned	1800 fanned	1500 fanned	900 fanned	700 fanned	600 fanned	500 fanned
<b>Global [*2]</b>								Off	1200	900?	1400	1000	1000	900
<b>Premier [*3]</b>							Off	2000	2000	1700	1700	1600	1250	

\*1 Angle of nozzle changed at 9 ft. - 7 ft. about 30 deg. nozzle

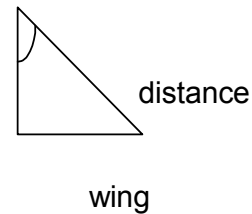

\*2 Angle at 45 deg. All distances

\*3 Angle changed between 30 deg. and 45 deg.

**DISTANCE AT WHICH AIR VELOCITY IS BEYOND 6000 fpm ~ 30 m/s (very rough idea)**

**FMC 4-5**  
**Global 8-9**  
**Premier 7-8**

# Air Assist Fluid Pressure

## Process

Apply Type I assisted with air on flat panel at incremental nozzle distances from 14 to 1 ft. The panel is mounted with a load cell to measure pressure on surfaces. The panel is inclined to be perpendicular to the jet.

## Pressure Transducer Results (lb.)

	1 ft.	2 ft.	3 ft.	4 ft.	5 ft.	6 ft.	7 ft.	8 ft.	9 ft.	10 ft.	11 ft.	12 ft.	13 ft.	14 ft.
<b>Elephant</b>	4.26	2.76	2.29	1.13	0.91	0.71	0.86	0.75	0.6	0.51	0.52	0.58	X	0.63
<b>FMC Air Only</b>	2.89	0.80	X	0.40	X	0.12	X	0.15	X	0.10	X	0.09	X	0.08
<b>FMC Air &amp; Glycol</b>	2.95	1.25	X	0.24	X	0.13	X	0.12	X	0.08	X	0.08	X	0.02
<b>Global Air Only</b>	2.51	0.53	X	0.15	X	0.09	X	0.05	X	0.05	X	0.05	X	0.05
<b>Global Air &amp; Glycol</b>	5.71	3.88	X	2.02	X	1.38	X	0.85	X	0.63	X	0.28	X	0.17
<b>Premier Air Only</b>	X	X	X	X	X	X	X	X	X	X	X	0.12?	X	0.15
<b>Premier 9 GPM</b>	X	X	X	X	X	X	X	X	X	X	X	X	X	0.17
<b>Premier 20 GPM</b>	X	X	X	X	X	X	X	X	X	X	X	X	X	0.22

# Deicing Fluid Temperature Test

## Process

Apply Type I to a test panel at incremental nozzle distances from 14 to 1 ft. Measure the various temperatures of the panel using a Electro-thermometer (Cooper Electro-therm model SH66A).

# Temperature Results deg. F.

	1 ft.	2 ft.	3 ft.	Ref.	4 ft.	5 ft.	6 ft.	Ref.	7 ft.	8 ft.	9 ft.	Ref.	10 ft.	11 ft.	12 ft.	Ref.	13 ft.	14 ft.
<b>Elephant</b>	165.4	164.0	148.6	-21	152.6	144.6	139.6	-21	135.3	137.0	133.2	-22	128.6	121.2	118.6	-22	112.8	115.0
<b>FMC</b>	76.9	90.2	64.7	-12	63.0	52.3	49.5	-12	48.4	47.1	45.1	-13	44.4	43.9	44.2	-15	48.1	57.6
<b>Global</b>	86.5	112.5	84.2	-11	90.9	85.0	74.7	-11	73.5	66.0	65.8	-12	66.4	62.2	59.3	-12	55.5	54.7
<b>Premier Glycol Only High Flow</b>	161.3	X	X	-15	125.1	X	102.8	-15	X	X	95.6 (off center)	-15	93.6	X	76.7	-12	X	71.4
<b>Premier 9 GPM</b>	137.3	108.9	90.0	X	71.1	70.0	67.5	X	64.5	60.2	60.1	X	59.1	58.9	55.5	X	52.4	50.2
<b>Premier 20 GPM</b>	154.8	130.1	113.9	X	110.4	108.9	86.6	X	120.9	108.2	100.8	X	92.4	87.2	73.8	X	73.4	69.7



# Type IV Application

	3 ft.	6 ft.	9 ft.	12 ft.
Elephant / Refractometer Index *1	1.395	1.395	1.395	1.396
Elephant / Mil.Thickness	70	80	80	
FMC / Refractometer Index	1.396	1.396	1.396	1.395
FMC / Mil.Thickness	80	30	45	50
Global / Refractometer Index	1.396	1.396	1.396	1.396
Global / Mil.Thickness	50	65	80	80
Premier / Refractometer Index	1.395	1.395	1.395	1.396
Premier / Mil. Thickness	50	70	70	80

\*1 without Air Assist

## Forced Air Sound Level Recordings, Chicago Trials

Manufacturer	Outside dB level	dB level inside enclosed bucket
FMC	107 dB	82.5 dB
Global	100 dB	97 dB
Premier	109 dB	82.5 dB

Source data: APS Aviation

**NOTE:**

It is anticipated that in colder OAT (outdoor air temp), the sound frequency and dB level will both increase.

Measurements were recorded for a minimum of 30 seconds.

Outside dB level recordings were taken at ground level, immediately beneath the enclosed bucket, with the enclosed bucket raised approximately 14 feet.

# CHICAGO TRIALS

## Forced Air Systems Fluid Viscosity Degradation

Spindle SC4-31/13R, 33 min 20 sec, 10 ml, 20° C, 0.3 rpms

