

Aircraft Full-Scale Test Program for the 1998/99 Winter



Prepared for

Transportation Development Centre

On behalf of

Civil Aviation

Transport Canada

and

The Federal Aviation Administration

William J. Hughes Technical Center



October 1999

Aircraft Full-Scale Test Program for the 1998/99 Winter



by

Michael Chaput,
Medhat Hanna,
Elio Ruggi and
Jeff Mayhew





October 1999

The contents of this report reflect the views of APS Aviation Inc. and not necessarily the official view or opinions of the Transportation Development Centre of Transport Canada.

The Transportation Development Centre does not endorse products or manufacturers. Trade or manufacturers' names appear in this report only because they are essential to its objectives.

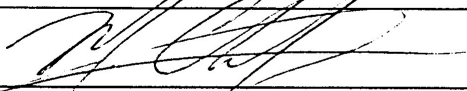
DOCUMENT ORIGIN AND APPROVAL RECORD

Prepared by:	 Michael Chaput Consultant	<u>MARCH 16, 2000</u> Date
And by:	Medhat Hanna, Elio Ruggi, and Jeff Mayhew	

Reviewed by:	 John D'Avirro Program Manager	<u>March 15, 2000</u> Date
Approved by:	 R.V. Potter, PhD Vice-President Programs & QA	<u>14 Mar/00</u> Date

ACKNOWLEDGEMENTS

Special thanks are extended to Frank Eyre, and Barry Myers of the Transportation Development Centre for their participation, contribution and guidance in the preparation of this document.

Un sommaire français se trouve avant la table des matières.

PREFACE

At the request of the Transportation Development Centre of Transport Canada, APS Aviation Inc. has undertaken a research program to advance aircraft ground deicing/anti-icing technology. The specific objectives of the APS test program are the following:

- To develop holdover time tables for new anti-icing fluids, and to validate fluid-specific and SAE holdover time tables;
- To gather enough supplemental experimental data to support the development of a deicing-only table as an industry guideline;
- To examine conditions for which contamination due to anti-icing fluid failure in freezing precipitation fails to flow from the wing of a jet transport aircraft when subjected to speeds up to and including rotation;
- To measure the jet-blast wind speeds developed by commercial airliners in order to generate air-velocity distribution profiles (to predict the forces that could be experienced by deicing vehicles), and to develop a method of evaluating the stability of deicing vehicles during live deicing operations;
- To determine the feasibility of examining the surface conditions on wings before takeoff through the use of ice-contamination sensor systems, and to evaluate the sensitivity of one ice-detection sensor system;
- To evaluate the use of warm fuel as an alternative approach to ground deicing of aircraft;
- To evaluate hot water deicing to determine safe and practicable limits for wind and outside ambient temperature;
- To document the appearance of fluid failure, to measure its characteristics at the point of failure, and to compare the failures of various fluids in freezing precipitation;
- To determine the influence of fluid type, precipitation (type and rate), and wind (speed and relative direction) on both the locations and times to fluid failure initiation, with special attention to failure progression on the Canadair Regional Jet and on high-wing turboprop commuter aircraft;
- To evaluate snow-weather data from previous winters to identify a range of snow-precipitation suitable for the evaluation of holdover time limits;
- To compare the holdover times from natural and artificial snow trials and to evaluate the functionality of the NCAR simulated snowmaking system; and
- To develop a plan for implementing a full-scale wing test facility that would enable the current testing of deicing and anti-icing fluids in natural and artificial freezing precipitation on a real aircraft wing.

The research activities of the program conducted on behalf of Transport Canada during the 1998/99 winter season are documented in twelve reports. The titles of these reports are as follows:

- TP 13477E Aircraft Ground De/Anti-icing Fluid Holdover Time Field Testing Program for the 1998/99 Winter;
- TP 13478E Aircraft Deicing Fluid Freeze Point Buffer Requirements for Deicing Only Conditions;
- TP 13479E Contaminated Aircraft Takeoff Test for the 1998/99 Winter;
- TP 13480E Air Velocity Distribution of Wing-Mounted Aircraft Engines;
- TP 13481E Evaluation of Ice Detection Sensor Capabilities for End-of-Runway Application;
- TP 13482E Evaluation of Warm Fuel as an Alternative Approach to Deicing;
- TP 13483E Hot Water Deicing of Aircraft;
- TP 13484E Characteristics of Failure of Aircraft Anti-Icing Fluids Subjected to Precipitation;
- TP 13485E Aircraft Full-Scale Test Program for the 1998/99 Winter;
- TP 13486E Evaluation of Snow Weather Data;
- TP 13487E Development of a Plan to Implement a Full-Scale Test Site; and
- TP 13488E Evaluation of NCAR's Snow Generation System.

This report, TP 13485E, has the following objective:

- To determine the influence of fluid type, precipitation (type and rate), and wind (speed and relative direction) on both the locations and times to fluid failure initiation, with special attention to failure progression on the Canadair Regional Jet and on high-wing turboprop commuter aircraft.

This objective was not satisfied because aircraft were not made available. Several related objectives were met primarily through field trials at Dorval Airport.

ACKNOWLEDGEMENTS

This research has been funded by the Civil Aviation Group, Transport Canada, and with support from the Federal Aviation Administration. This program could not have been accomplished without the participation of many organizations. APS would like to thank, therefore, the Transportation Development Centre of Transport Canada, the Federal Aviation Administration, the National Research Council Canada, Atmospheric Environment Services Canada, Transport Canada, and several fluid manufacturers. Special thanks are extended to USAirways Inc., Delta Airlines, Royal Airlines, Air Canada, the National Research Council Canada, Canadian Airlines International, AéroMag 2000, Aéroport de Montreal, the Greater Toronto Airport Authority, Hudson General, Union Carbide, RVSI, Cox and Company Inc., the Department of National Defence, and Shell Aviation, for provision of personnel and facilities and for their co-operation on the test program. APS would like also to acknowledge the dedication of the research team, whose performance was crucial to the acquisition of hard data.



1. Transport Canada Publication No. TP 13485E		2. Project No. 9543-7		3. Recipient's Catalogue No.	
4. Title and Subtitle Aircraft Full-Scale Test Program for the 1998/1999 Winter				5. Publication Date October 1999	
				6. Performing Organization Document No.	
7. Author(s) M. Chaput, M. Hanna, E. Ruggi, and J. Mayhew				8. Transport Canada File No. ZCD2450-B-14	
9. Performing Organization Name and Address APS Aviation Inc. 1100 René Lévesque Blvd. West Suite 1340 Montreal, Quebec H3B 4N4				10. PWGSC File No. XSD-8-01307	
				11. PWGSC or Transport Canada Contract No. T8200-8-8589	
12. Sponsoring Agency Name and Address Transportation Development Centre (TDC) 800 René Lévesque Blvd. West Suite 600 Montreal, Quebec H3B 1X9				13. Type of Publication and Period Covered Final	
				14. Project Officer Barry B. Myers	
15. Supplementary Notes (Funding programs, titles of related publications, etc.) <p>Research reports produced on behalf of Transport Canada for testing during previous winters are available from the Transportation Development Centre (TDC). Twelve reports (including this one) were produced as part of this winter's research program (1998-99). Their subject matter is outlined in the preface.</p>					
16. Abstract <p>Frost deposition trials on the Bombardier Canadair Regional Jet were conducted on three occasions. The patterns of frost development were similar in all tests, regardless of the rate of frost deposition. Frost begins forming on the trailing edge outboard of the aileron, the aileron, and the wing tip. It also accumulates on the outboard flap section, outboard spoilers, and outer mid-wing sections. No frost was present on the leading edge in any of these tests.</p> <p>One test was used to estimate the surface area coverage, frost diameters, and frost thickness on the wing. The heaviest accumulations occurred on the trailing edge outboard of the aileron, the wing tip, and the aileron. These sections exhibited 94 percent, 80 percent, and 12 percent area coverage by frost, respectively. No other wing section was more than 9 percent frost covered. Average frost diameters in the various wing sections ranged from 1 mm to more than 5 mm. Frost heights ranged from 0.20 to 0.80 mm. Frost densities ranged from 2 to 4 peaks/cm² in the lightly frosted wing sections. No frost densities were calculated for the heavily frosted sections because individual peaks were indistinguishable.</p> <p>The test used to document frost diameters, heights, and surface area coverage was representative of a light frost. The figures reported in this document would certainly increase in heavy frost.</p> <p>Preparations for additional tests to address de/anti-icing fluid failure characteristics under conditions of freezing precipitation were made but not implemented because no aircraft were available.</p>					
17. Key Words Frost, frost diameters, Bombardier Canadair Regional Jet, frost thickness			18. Distribution Statement Limited number of copies available from the Transportation Development Centre E-mail: <i>tdccdt@tc.gc.ca</i>		
19. Security Classification (of this publication) Unclassified	20. Security Classification (of this page) Unclassified	21. Declassification (date) —	22. No. of Pages xvi, 78, apps	23. Price Shipping/ Handling	



1. N° de la publication de Transports Canada TP 13485E		2. N° de l'étude 9543-7		3. N° de catalogue du destinataire	
4. Titre et sous-titre Aircraft Full-Scale Test Program for the 1998/1999 Winter				5. Date de la publication Octobre 1999	
				6. N° de document de l'organisme exécutant	
7. Auteur(s) M. Chaput, M. Hanna, E. Ruggi et J. Mayhew				8. N° de dossier - Transports Canada ZCD2450-B-14	
9. Nom et adresse de l'organisme exécutant APS Aviation Inc. 1100, boul. René-Lévesque Ouest Bureau 1340 Montréal, Québec H3B 4N4				10. N° de dossier - TPSGC XSD-8-01307	
				11. N° de contrat - TPSGC ou Transports Canada T8200-8-8589	
12. Nom et adresse de l'organisme parrain Centre de développement des transports (CDT) 800, boul. René-Lévesque Ouest Bureau 600 Montréal (Québec) H3B 1X9				13. Genre de publication et période visée Final	
				14. Agent de projet Barry B. Myers	
15. Remarques additionnelles (programmes de financement, titres de publications connexes, etc.) <p>Les rapports de recherche produits au nom de Transports Canada sur les essais réalisés au cours des hivers antérieurs peuvent être obtenus auprès du Centre de développement des transports (CDT). Le programme de la saison hivernale 1998-1999 a donné lieu à douze rapports (dont celui-ci). On trouvera dans la préface l'objet de ces rapports.</p>					
16. Résumé <p>Trois essais de formation de givre ont été réalisés à l'aide du Regional Jet de Bombardier Canadair. Les mêmes tendances ont alors été observées, peu importe le taux de précipitations givrantes. Ainsi, le givre commence à se former sur le bord de fuite à l'extérieur de l'aileron, sur l'aileron même et sur le bout de l'aile. Il s'accumule également sur la zone extérieure des volets et sur les déporteurs et demi-ailes externes. Aucun givre ne s'est formé sur le bord d'attaque de l'aile, durant aucun des essais.</p> <p>Un des essais a servi à mesurer la superficie couverte par le givre, le diamètre des granules de givre et l'épaisseur de la couche de givre sur la voilure. Les accumulations les plus abondantes ont été enregistrées sur le bord de fuite à l'extérieur de l'aileron, sur le bout de l'aile et sur l'aileron. Ces zones étaient recouvertes à 94 p. 100, 80 p. 100 et 12 p. 100, respectivement, de givre. Aucune autre partie de l'aile n'était couverte à plus de 9 p. 100. Le diamètre moyen des granules de givre contaminant les diverses parties d'aile variait de 1 mm à plus de 5 mm. L'épaisseur de la couche de givre allait de 0,20 à 0,80 mm. La densité du givre sur les zones légèrement givrées variait de 2 à 4 «pics» par cm². La densité du givre n'a pas été calculée dans les zones fortement atteintes, car les «pics» se confondaient et ne pouvaient être dénombrés.</p> <p>L'essai utilisé pour obtenir ces mesures reproduisait des conditions de givrage léger. Les chiffres seraient sans doute supérieurs dans des conditions de givrage intense.</p> <p>D'autres essais avaient été prévus, devant porter sur la perte d'efficacité des fluides dégivrants/antigivrage sous précipitations givrantes, mais il n'ont pu avoir lieu, faute d'avion disponible.</p>					
17. Mots clés Givre, diamètre des granules de givre, Regional Jet de Bombardier Canadair, épaisseur de la couche de givre			18. Diffusion Le Centre de développement des transports dispose d'un nombre limité d'exemplaires. Courriel : tdccdt@tc.gc.ca		
19. Classification de sécurité (de cette publication) Non classifiée		20. Classification de sécurité (de cette page) Non classifiée		21. Déclassification (date) —	22. Nombre de pages xvi, 78, ann.
					23. Prix Port et manutention

EXECUTIVE SUMMARY

At the request of the Transportation Development Centre of Transport Canada, APS Aviation Inc. has undertaken a research program to further advance aircraft ground deicing/anti-icing technology. The primary objectives of this study were to:

- Determine the influences fluid type, precipitation (type and rate), and wind (speed and direction) have on the location of and time to fluid failure initiation, and to document failure progression on Canadair Regional Jet aircraft and high-wing turboprop commuter aircraft;
- Determine the roughness of frost formations on the wings of Canadair Regional Jet aircraft; and
- Observe the fluid property behaviour of Type IV propylene glycol-based fluids hydrated through active frost.

Description and Processing of Data

A set of de/anti-icing fluid failure trials on full-scale aircraft was designed for implementation during winter 1998-99. The trials involved simultaneous application of Type I and Type IV fluids on standard flat plates and aircraft wings in natural precipitation conditions. Standard flat plate test procedures used in fluid holdover time testing were to be followed. The aircraft – a Canadair Regional Jet and an ATR 42 – were to be tested in a static position. However, no fluid failure trials were conducted on operational aircraft because no aircraft were available for testing.

Frost formation tests on Canadair Regional Jet aircraft were conducted during three overnight periods. Frost deposition patterns were mapped by the wing observer prior to each test. To determine the mean or average frost formation diameter and height, and to estimate the surface area covered by frost formations and the density of frost, a series of photographs of each of the wing sections were taken.

A total of eleven tests were conducted in two overnight sessions to observe the fluid behaviour characteristics of Type IV fluid in active frost conditions.

Results and Conclusions

The lack of fluid failure trials with full-scale aircraft during winter 1998/99 demonstrates the need to implement a full-scale deicing test site, centred around a wing test bed.

In the frost formation tests, the patterns of frost development on the wings of the Canadair Regional Jet were similar, regardless of the intensity of frost deposition. Frost initially developed on the trailing edge outboard of the aileron, the wing tip, and the aileron itself. It also accumulated on the outboard flap section, outboard spoilers, and outer mid-wing sections. The entire leading edge of the aircraft, which consists of highly polished aluminum, was frost-free in all trials.

One test, which could be used to represent the onset of frost formation or light frost-forming conditions, was used to determine frost diameters, heights, and surface area coverage. The surface area coverage of the frost formation on the trailing edge outboard of the aileron and on the wing tip were 94 percent and 80 percent respectively, exceeding that of any other wing section. The aileron was next, with 12 percent of its surface covered with frost. None of the remaining wing sections had more than 9 percent area coverage by frost. The polished leading edge had no frost whatsoever.

The same trend was apparent following the estimation of mean frost diameters and mean frost heights for each wing section. Mean frost diameters of 5 mm and mean frost heights of 0.5 to 0.8 mm were observed on the trailing edge outboard of the aileron and the wing tip. The values were larger than those of the other wing sections, where diameters ranged from 1 to 4 mm and heights were 0.20 mm or less.

Frost densities ranged from 2 to 4 peaks/cm² in the lightly frosted wing sections. No frost densities were calculated for the heavily frosted sections because individual peaks were indistinguishable.

The test used to document frost diameters, heights, and surface area coverage was representative of a light frost. The figures would certainly increase in heavy frost.

An independent series of trials examined the feasibility of using artificial lighting to depress frost formation.

Data collected throughout the test sessions did not provide any evidence that hydration from exposure to active frost alters fluid properties.

SOMMAIRE

À la demande du Centre de développement des transports de Transports Canada, APS Aviation Inc. a lancé un programme de recherche visant à développer la technologie de dégivrage/antigivrage des avions au sol, et à accroître la sécurité du transport aérien. Le programme visait les objectifs suivants :

- Déterminer l'influence du type de fluide dégivrant/antigivrage utilisé, de la précipitation (type et taux) et du vent (vitesse et direction) sur l'endroit où s'amorce la perte d'efficacité et le délai d'apparition de la perte d'efficacité initiale, et documenter la progression de la perte d'efficacité sur un Regional Jet de Bombardier Canadair, un avion de transport régional à turbopropulseurs et voilure haute.
- Déterminer la rugosité des accrétions de givre sur les ailes d'un Regional Jet de Bombardier Canadair.
- Observer l'évolution des propriétés des fluides de type IV à base de propylène glycol lorsque hydratés par des précipitations givrantes.

Description des essais et traitement des données

Une série d'essais en vraie grandeur portant sur la perte d'efficacité de liquides dégivrants/antigivrage et mettant en jeu des avions réels ont été conçus en prévision de l'hiver 1998-1999. Ces essais devaient comporter l'application parallèle de fluides de type I et de type IV sur des plaques planes et des ailes d'avion, dans des conditions de précipitations naturelles. Il était prévu d'utiliser, pour les essais sur plaques planes, le même protocole que pour les essais de durée d'efficacité

des fluides. Quant aux avions - un Regional Jet de Bombardier Canadair et un ATR 42 -, ils devaient demeurer à l'arrêt pendant les essais. Mais aucun essai de perte d'efficacité sur avion n'a été réalisé, faute d'appareil disponible aux moments propices.

Les essais de formation de givre ont été réalisés à l'aide du Regional Jet de Bombardier Canadair. Ils se sont étalés sur trois nuits. Un observateur cartographiait le givre sur la voilure avant l'application de fluide. Pour déterminer le diamètre moyen des granules de givre, l'épaisseur moyenne de la couche de givre ainsi que la superficie et la densité du givre, des photographies étaient prises de toutes les parties de l'aile.

Onze essais, répartis sur deux nuits, ont permis d'observer le comportement des fluides antigivrage de type IV dans des conditions givrantes.

Résultats et conclusions

Le fait que les essais sur la perte d'efficacité des fluides aient dû être contremandés illustre la nécessité d'implanter une installation d'essai en vraie grandeur, articulée autour d'une aile d'avion.

Les essais de formation de givre ont révélé des tendances semblables quant à la progression du givre sur les ailes du Regional Jet de Bombardier Canadair, sans égard à l'intensité des précipitations givrantes. Le givre apparaissait en premier sur le bord de fuite à l'extérieur de l'aileron, sur le bout de l'aile et sur l'aileron même. Il s'accumulait également sur la partie extérieure des volets et sur les déporteurs et demi-ailes externes. Le bord d'attaque de l'aile, constitué d'aluminium poli, est demeuré exempt de givre lors de tous les essais.

Un des essais, qui pouvait représenter la phase initiale du givrage ou des précipitations givrantes légères, a été utilisé pour déterminer le diamètre des granules de givre ainsi que l'épaisseur de la couche de givre et la superficie couverte. La superficie couverte par le givre atteignait 94 p. 100 et 80 p. 100, respectivement, sur le bord de fuite à l'extérieur de l'aileron et le bout de l'aile, soit plus que partout ailleurs sur l'aile. Suivait l'aileron, dont la superficie givrée atteignait 12 p. 100. Aucune autre partie d'aile n'était givrée à plus de 9 p. 100. Le bord d'attaque était exempt de tout givre.

Ces tendances se sont confirmées lors de l'estimation de l'épaisseur et du diamètre moyens des dépôts de givre sur les différentes parties de l'aile. Un diamètre moyen de 5 mm et une épaisseur moyenne de 0,5 à 0,8 mm ont été observés sur le bord de fuite à l'extérieur de l'aileron et sur le bout de l'aile. Ces valeurs étaient supérieures à celles observées sur les autres parties de l'aile, où les diamètres variaient de 1 à 4 mm, et les épaisseurs atteignaient au plus 0,20 mm.

La densité du givre se situait entre 2 et 4 «pics» par cm², dans les parties d'aile les moins givrées. La densité du givre n'a pas été calculée dans les zones fortement atteintes, car les «pics» se confondaient et ne pouvaient être dénombrés.

L'essai utilisé pour obtenir ces mesures correspondait à des conditions de givrage léger. Dans des conditions de givrage intense, les chiffres seraient sans doute supérieurs.

Une série indépendante d'essais a porté sur la faisabilité d'utiliser un éclairage artificiel pour ralentir la formation de givre.

Rien, dans les données recueillies au cours des essais, ne permet de conclure que les propriétés des fluides dégivrants/antigivrage sont altérées par suite de leur hydratation sous précipitations givrantes.

CONTENTS

	Page
1. INTRODUCTION.....	1
1.1 Objectives.....	1
1.1.1 Fluid Failure Tests on Operational Aircraft.....	1
1.1.2 Frost Formation on Aircraft.....	2
1.1.3 Hydration of Anti-icing Fluids Exposed to Frost Conditions.....	2
2. METHODOLOGY.....	5
2.1 Fluid Failure Tests on Operational Aircraft.....	5
2.1.1 Test Sites.....	5
2.1.2 Test Plan.....	5
2.1.3 Equipment.....	7
2.1.4 Description of Test Procedures.....	12
2.1.5 Data Forms.....	14
2.1.6 Fluids.....	15
2.1.7 Personnel.....	15
2.2 Frost Formation on Aircraft.....	16
2.2.1 Test Sites.....	16
2.2.2 Test Plan.....	16
2.2.3 Equipment.....	17
2.2.4 Description of Test Procedures.....	17
2.2.5 Data Forms.....	17
2.2.6 Personnel.....	17
3. DESCRIPTION AND PROCESSING OF DATA.....	27
3.1 Fluid Failure Tests on Operational Aircraft.....	27
3.1.1 Overview of Test Sessions.....	27
3.2 Frost Formation on Aircraft.....	27
3.2.1 Description of the Canadair Regional Jet Wing.....	27
3.2.2 Overview of Test Sessions.....	27
3.2.3 Description and Reduction of the Data.....	32
3.2.3.1 Mapping of Frost Deposition.....	32
3.2.3.2 Frost Distribution in Plan Form.....	32
3.2.3.3 Frost in Profile.....	35
4. ANALYSIS AND OBSERVATIONS.....	39
4.1 Fluid Failure Tests on Operational Aircraft.....	39
4.2 Frost Formation on Aircraft.....	39
4.2.1 Mapping of Frost Patterns.....	39
4.2.2 Frost Distribution in Plan and Profile.....	44
4.2.3 Frost Self-Elimination Using Luminous Radiation.....	48
5. DISCUSSION.....	71
5.1 Fluid Failure Tests on Operational Aircraft.....	71
5.2 Frost Formation on Aircraft.....	71
6. CONCLUSIONS.....	73
6.1 Fluid Failure Tests on Operational Aircraft.....	73
6.2 Frost Formation on Aircraft.....	73
7. RECOMMENDATIONS.....	75
7.1 Fluid Failure Tests on Operational Aircraft.....	75
7.2 Frost Formation on Aircraft.....	75

LIST OF APPENDICES

- A** WORK STATEMENT – AIRCRAFT AND FLUID HOLDOVER TIME TESTS FOR WINTER 98/99
- B** EXPERIMENTAL PROGRAM – FULL-SCALE FLUID FAILURE TESTING
- C** REPORT – HYDRATION OF ANTI-ICING FLUID IN FROST CONDITIONS
- D** EXPERIMENTAL PROGRAM – HYDRATION OF ANTI-ICING FLUID IN FROST CONDITIONS
- E** FROST SELF-ELIMINATION USING LUMINOUS RADIATION

LIST OF FIGURES

	Page
2.1 Deicing Pad Location at Dorval Airport	6
2.2 Flat Plate Test Set-Up	10
2.3 Position of Equipment and Personnel.....	11
2.4 Index of Colours for Photos of Roughness on Aircraft Wing.....	18
3.1 Regional Jet Wing Sections	28
3.2 Meteorological Profile of Test Session: February 14-15	31
3.3 Frost Pattern on CL-65 Port Wing (ID# 1)	33
3.4 Plan Photo of Frost Formation on RJ Aileron.....	34
4.1 Frost Pattern of CL-65 Port Wing (ID # 1)	40
4.2 Frost Pattern on CL-65 Starboard Wing (ID # 1)	41
4.3 Frost Pattern on CL-65 Port Wing (ID # 2).....	42
4.4 Frost Pattern on CL-65 Port Wing (1:55 AM)	43
4.5 Frost Pattern on CL-65 Port Wing (ID # 3).....	45

LIST OF TABLES

2.1 Test Plan – Turboprop and Turbofan Full-Scale.....	8
3.1 General Summary of Test Conditions.....	29
4.1 Frost Diameter, Height, and Surface Area Coverage (ID # 3) of Frost Formations on a CL-65 Wing.....	46

LIST OF PHOTOS

Page

2.1 Precipitation Rate Measuring Equipment 19

2.2 Field Lab for Full-Scale Tests..... 19

2.3 Rolling Stairs and Step Ladders Used in Full-Scale Aircraft Trials 21

2.4 Mast-lighting Used for Aircraft Illumination..... 21

2.5 Misco Refractometer..... 23

2.6 Hand-Held Ice Detection Sensor by RVSI ID-1H..... 23

2.7 Spar/Cox Sensor 25

2.8 Painted Coins Used in Documentation of Roughness of Frost Formation..... 25

3.1 Test Set-up for Flat Plate Trials in Frost Conditions 37

3.2 Profile Photograph of Frost Deposition and Millimetre-Scale Ruler 37

4.1 Frost Accumulation on Port Wing (ID# 1) 49

4.2 Frost Accumulation on Starboard Wing (ID# 1)..... 49

4.3 Heavy Frost Accumulation on the Aileron and Trailing Edge Outboard of the
Aileron of the Starboard Wing (ID# 1)..... 51

4.4 Frost Accumulation on Port Wing (ID# 1) 51

4.5 Frost Accumulation on Port Wing (ID# 2) 53

4.6 Heavy Frost Accumulation on the Wing Tip (ID# 2)..... 53

4.7 Frost Accumulation on Port Wing Shortly After Arrival of Aircraft..... 55

4.8 Frost Accumulation on Port Wing (ID# 3) 55

4.9 Frost Accumulation on the Port Wing (ID# 3)..... 57

4.10 Plan Photo of Frost Formation on the Aileron (ID# 3) 57

4.11 Overall Photo of the Frost Formation on the Aileron (ID# 3)..... 59

4.12 Plan Photo of the Frost Formation on the Outboard Spoilers (ID# 3) 59

4.13 Overall Photo of the Frost Formation on the Outboard Spoilers (ID# 3)..... 61

4.14 Plan Photo of the Frost Formation on the Outboard Flap (ID# 3) 61

4.15 Overall Photo of the Frost Formation on the Outboard Flap 63

4.16 Plan Photo of the Frost Formation on the Mid-Wing (ID# 3) 63

4.17 Overall Photo of the Frost Formation on the Mid-Wing (ID# 3) 65

4.18 Plan Photo of the Frost Formation on the Wing-Tip (ID# 3)..... 65

4.19 Overall Photo of the Frost Formation on the Wing Tip (ID# 3)..... 67

4.20 Plan Photo of the Frost Formation on the Trailing Edge (ID# 3)..... 67

4.21 Overall Photo of the Frost Formation on the Trailing Edge (ID# 3) 69

4.22 Photo of CL-65 Leading Edge (ID# 3) 69

GLOSSARY

APS	APS Aviation Inc.
BFG	BF Goodrich
READAC	Remote Environmental Automatic Data Acquisition Concept
RJ	Regional Jet
RVSI	Robotic Vision Systems Inc.
TDC	Transportation Development Centre

This page intentionally left blank.

1. INTRODUCTION

At the request of the Transportation Development Centre, APS has undertaken a research program to further advance aircraft ground deicing/anti-icing technology.

Aircraft ground deicing/anti-icing has been the subject of concentrated industry attention over the past decade due to a number of fatal aircraft accidents. Recent attention has been placed on the enhancement of anti-icing fluids, to provide an extended duration of protection against further contamination following initial deicing. This has led to the development of fluid holdover time tables (HOTs), for use by aircraft operators, and accepted by regulatory authorities. New fluids continue to be developed specifically to prolong fluid holdover times without compromising airfoil aerodynamics.

APS has conducted over 250 full-scale aircraft tests since 1993. Over the past few years, securing aircraft for full-scale testing has become increasingly difficult, due to the complexities of these trials, and need to coordinate test equipment availability, aircraft availability, and test crew availability with suitable weather conditions.

This report contains the results of research conducted by APS Aviation in 1998/99 on several subjects related to full-scale aircraft testing. The studies included in this report are:

- Fluid failure tests on operational aircraft; and
- Frost formation tests on a Canadair Regional Jet aircraft.

1.1 Objectives

This subsection provides an outline of the full-scale research that was performed by APS Aviation on behalf of the Transportation Development Centre of Transport Canada, including the overall objectives of the study.

1.1.1 Fluid Failure Tests on Operational Aircraft

The primary objective of this project was to determine the influence of fluid type, precipitation (type and rate), and wind (speed and direction) has on the location and time of fluid failure initiation, and to document the failure progression on service aircraft wings. The detailed work statement is contained in Appendix A and the experimental program is laid out in Appendix B.

To support the primary objective, several related objectives were subsequently defined and are listed below:

- To generate data that can be used to assist pilots with visual identification of fluid failure;
- To generate data to be used to assess a pilot's field of view during adverse conditions of winter precipitation for selected aircraft;
- To compare the performance of de/anti-icing fluids on aircraft surfaces with the performance of de/anti-icing fluids on flat plates;
- To examine the pattern of failure using Type IV fluid brands not tested in the past; and
- To further investigate progression of failure on the Canadair Regional Jet and on high-wing turboprop aircraft in crosswind conditions.

Despite the substantial groundwork, which had been undertaken to organize full-scale test sessions, all attempts to obtain aircraft for full-scale testing were unsuccessful. While no data were gathered, the test procedure is described in detail in Section 2, and will be followed in any future tests.

1.1.2 Frost Formation on Aircraft

The purpose of this activity was to determine the roughness of frost formation on the wings on a Canadair Regional Jet aircraft, and to characterize the frost by measuring its thickness (or height), calculating its mean frost diameter, and determining its density.

An independent series of trials examining the feasibility of using artificial lighting to suppress frost formation was conducted. Those tests are described and the results are reported in Appendix E of this document.

1.1.3 Hydration of Anti-icing Fluids Exposed to Frost Conditions

This preliminary research is based on concerns of an undocumented incident that involved an overnighting aircraft treated with propylene glycol-based anti-icing fluid (anti-icing fluid applied to the aircraft the night before a scheduled morning flight). During rotation, the flight crew experienced noticeable flight surface control resistance.

It was suggested that hydration of the anti-icing fluid as a result of active frost could alter the fluid properties and, moreover, affect flight surface functionality.

The objective of this study was to observe the behaviour of Type IV propylene glycol-based fluids during active frost.

The results of this study are shown in Appendix C and the test procedure for this study appears in Appendix D.

This page intentionally left blank.

2. METHODOLOGY

This section of the report details the complete environment and support infrastructure that surround testing of this nature, and includes information about test facilities, equipment, procedures, and personnel.

Although no tests were conducted, this methodology is presented since the same procedures will be followed in any future tests performed.

2.1 Fluid Failure Tests on Operational Aircraft

This subsection describes tests that focus on identification and evaluation of characteristics associated with fluid failure.

Failure time is defined as the time required for the accumulating precipitation to fail to be absorbed by the fluid.

A surface is failed if:

- There is a visible accumulation of snow on the fluid or on the wing surface; or
- Ice is visible on the fluid or surface.

2.1.1 Test Sites

Aircraft fluid failure tests were planned at Dorval International Airport, Montreal, during the 1998/99 test season. Consideration was also given to conducting tests in other cities, such as Toronto, Ottawa, and Quebec City, depending on aircraft availability.

These tests were to be conducted at the Dorval Airport central deicing facility, operated by Aéromag 2000 Inc. (see Figure 2.1). The APS test site (where flat plate tests to determine fluid holdover times are conducted) is also indicated in Figure 2.1, as is Environment Canada's automated weather station.

2.1.2 Test Plan

A dry run and up to five one-night test sessions were planned for winter 1998/99. Planning was based on the following aircraft and operators:

FIGURE 2.1
DEICING PAD LOCATION AT DORVAL AIRPORT

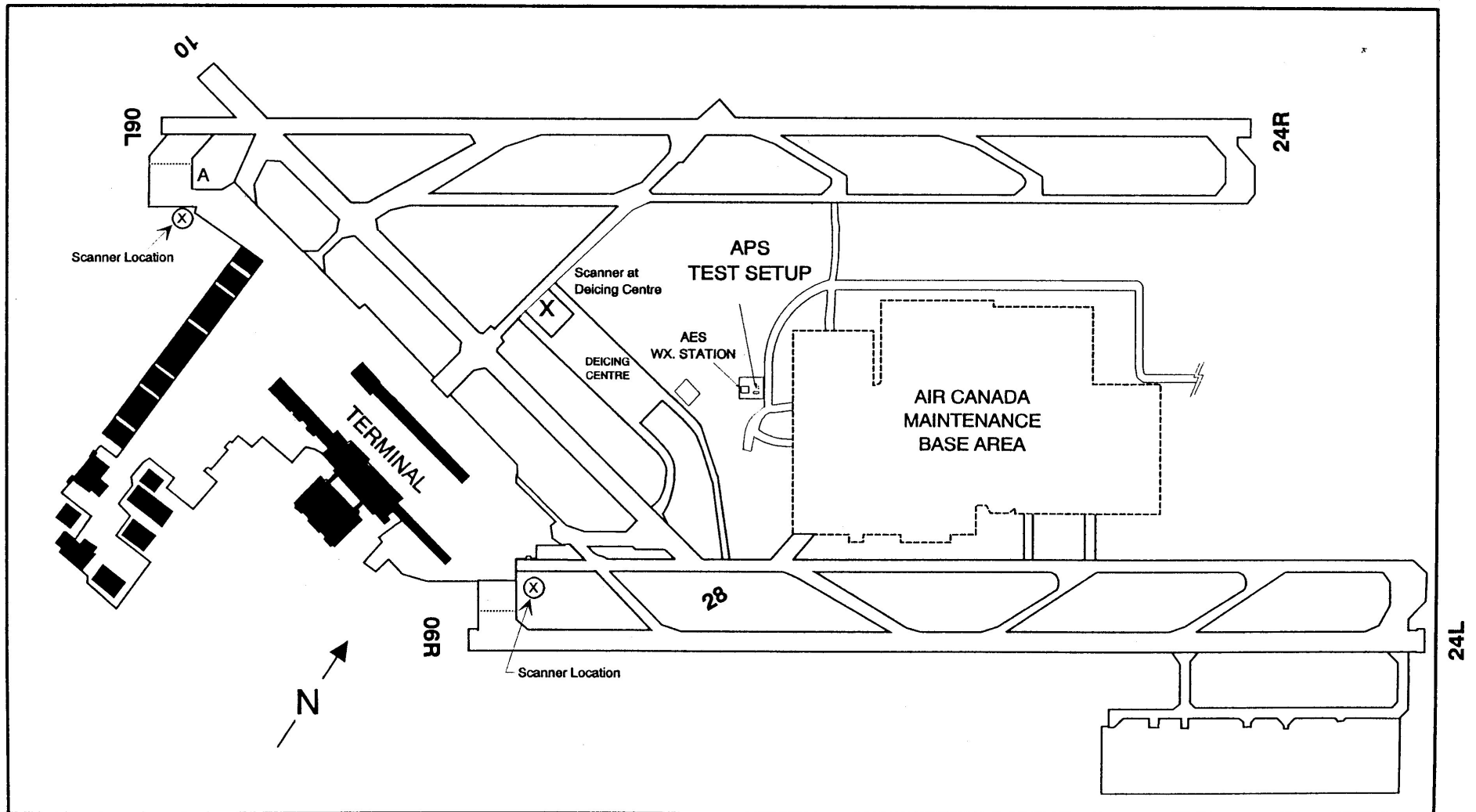

Aircraft	Airline
Canadair Regional Jet (CL-65)	Air Canada
ATR 42	Inter-Canadian

Test sessions on Canadair Regional Jet aircraft were scheduled to take place after normal airport operating times (between 23:00 and 06:00). The ATR 42 aircraft were to be made available for several hours during the middle of the day.

Tests were planned for the following conditions:

Aircraft Orientation:	headwind, tailwind, crosswind
Precipitation type:	snow, freezing rain, freezing drizzle
Fluids:	Type I, Type IV

Scheduling was based on a reasonable forecast of precipitation for the evening/overnight, provided that the airline was available to support and participate in the tests.

Forecasts were monitored daily, using radio, television, and Internet sources. A forecast was obtained from the Environment Canada web site for Dorval. This forecast prompted an alert that was issued to all tests and airline personnel related to the fluid tests. The weather system was closely monitored as the storm approached. This was done via direct one-to-one telephone communication with a trained Environment Canada professional using Environment Canada's 1-900 service.

For each session, up to ten tests were planned (see Table 2.1) using both Type I and Type IV fluids. Aircraft were to be positioned at a pre-determined orientation prior to the start of the first test. The test plan included the re-orientation of the aircraft relative to wind direction between individual tests during the course of the test session.

2.1.3 Equipment

Five full-scale test sessions were scheduled at Dorval Airport during the winter 1998/99 test season. Test aircraft were to be provided by Air Canada (Canadair CL-65), and Inter-Canadian (ATR 42). Aéromag 2000 Inc., operators of the deicing facility at Dorval, supplied specially equipped vehicles and personnel for the application of fluids. Fluids were provided by Union Carbide.

Photo 2.1 shows the equipment kit used in the past to measure precipitation rates. Two collection pans with base dimensions identical to standard flat test plates, were used to capture precipitation.

TABLE 2.1
**TEST PLAN FOR
 TURBOPROP FULL-SCALE TESTS**

WITH PRECIPITATION

RUN #	FLUID TYPE	AIRCRAFT ORIENTATION	WING
1	I	Tail	Starboard
2	I	Tail	Port
3	I	Cross*	Starboard
4	I	Cross*	Port
5	I	Cross**	Starboard
6	I	Cross**	Port
7	I	Head	Starboard
8	I	Head	Port

* Wind direction such that starboard wing is on upwind side and port wing is on downwind side.

** Wind direction such that port wing is on upwind side and starboard wing is on downwind side.

**TEST PLAN FOR
 TURBOFAN FULL-SCALE FLUID FAILURE TESTS**

OCCASION	RUN #	FLUID ⁽¹⁾ TYPE	A/C ORIENTATION
1	1	I / IV	Tail
1	2	I	Tail
1	3	I	Tail
1	4	I / IV	Cross
1	5	I / IV	Cross
1	6	I	Cross
1	7	I	Cross
1	8	I / IV	Head
1	9	I	Head
1	10	I	Head

⁽¹⁾ Selection of fluid is dependent upon precipitation rate.

An electronic balance, shielded with plexiglass to reduce wind effects, was to be used to weigh the precipitation. The rate station was to be positioned on a table in a rented cube van. The van was to be positioned adjacent to the test stand. Photo 2.2 shows the truck typically used during the full-scale tests. The space in the van has also been used for debriefing the test team between tests.

Six rolling staircases and several stepladders (see Photo 2.3) were to be positioned around each aircraft wing. Wing illumination was supplied by mobile mast-light units. Each unit consists of four 1 000W flood lights. A 6 kW diesel generator (an integral component of each unit) was also used to supply current for the lights and other electrical requirements. This lighting arrangement provides a significant improvement over those used prior to 1997/98 (with respect to light set-up time). Photo 2.4 shows the mast-lights ready for testing.

During full-scale aircraft trials, standard flat plate tests are always conducted in tandem on a 10°-inclined standard flat plate test stand. The plates were marked with three parallel lines, 2.5 cm (1"), 15 cm (6") and 30 cm (12") from the top of the plates. The plates were also marked with 15 crosshairs, which served as criteria for the calling of fluid failure on flat plate test surface. Figure 2.2 shows a schematic of a test stand and one of the test plates used. Figure 2.3 provides a schematic of the positioning of major equipment and key personnel about the aircraft.

A list of the mobile equipment used by each of the test team members is shown on pages 29 and 30 of Appendix B. The mobile equipment required for the truck is listed on page 31 of Appendix B.

Sampling kits consisted of spatulas and small collection and storage containers and were distributed to personnel responsible for the collection of fluid samples at failure locations on the wing. The freeze points of the fluid samples were to be measured immediately with a hand-held Brix-scale refractometer. Photo 2.5 shows the refractometer used by APS and most of the industry.

Photo 2.6 shows the hand-held ID 1H ice contamination sensor unit made available by Robotic Vision Systems Inc. (RVSI). The unit consists of a hand-held camera type sensor to scan the wing surface and measure the response to ice, a main power supply, and an image storage unit. The entire system is portable.

Photo 2.7 shows the Spar/Cox sensor. The unit uses infrared technology initially developed by Spar (but marketed and manufactured by Cox and Co.) to detect ice accumulation on aircraft surfaces from remote positions. The unit tested was not yet made available as a hand-held unit, and so for

FIGURE 2.2
FLAT PLATE TEST SET-UP

TEST PLATFORM

TYPICAL FLAT PLATE

FOUR TEST PLATES (INCLINED @ 10° SLOPE)

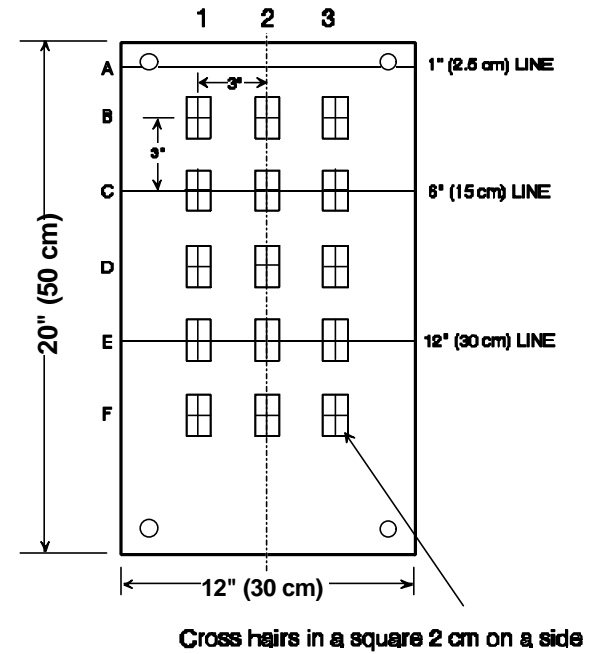
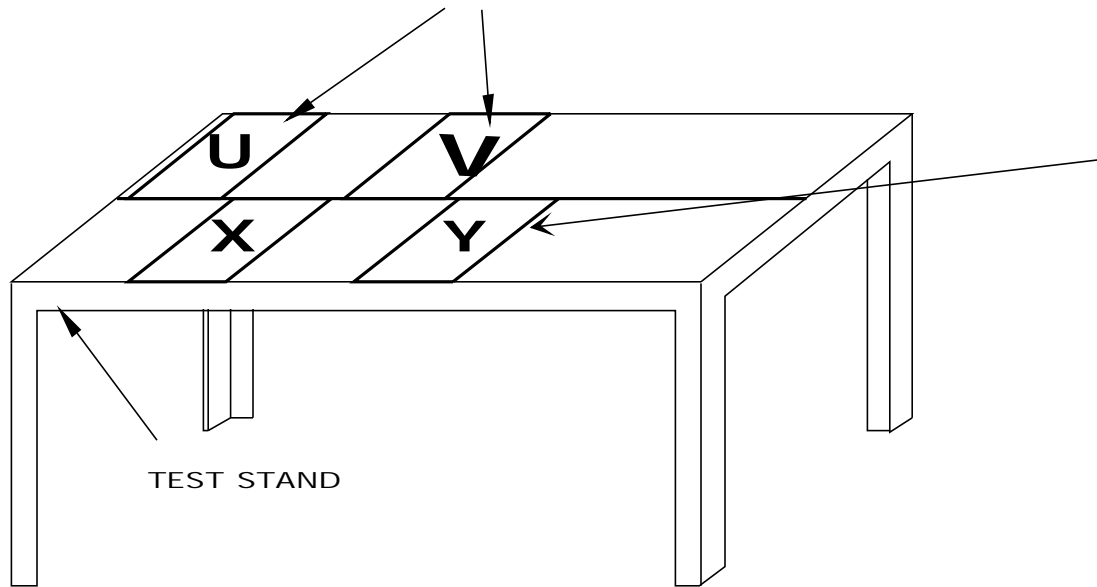
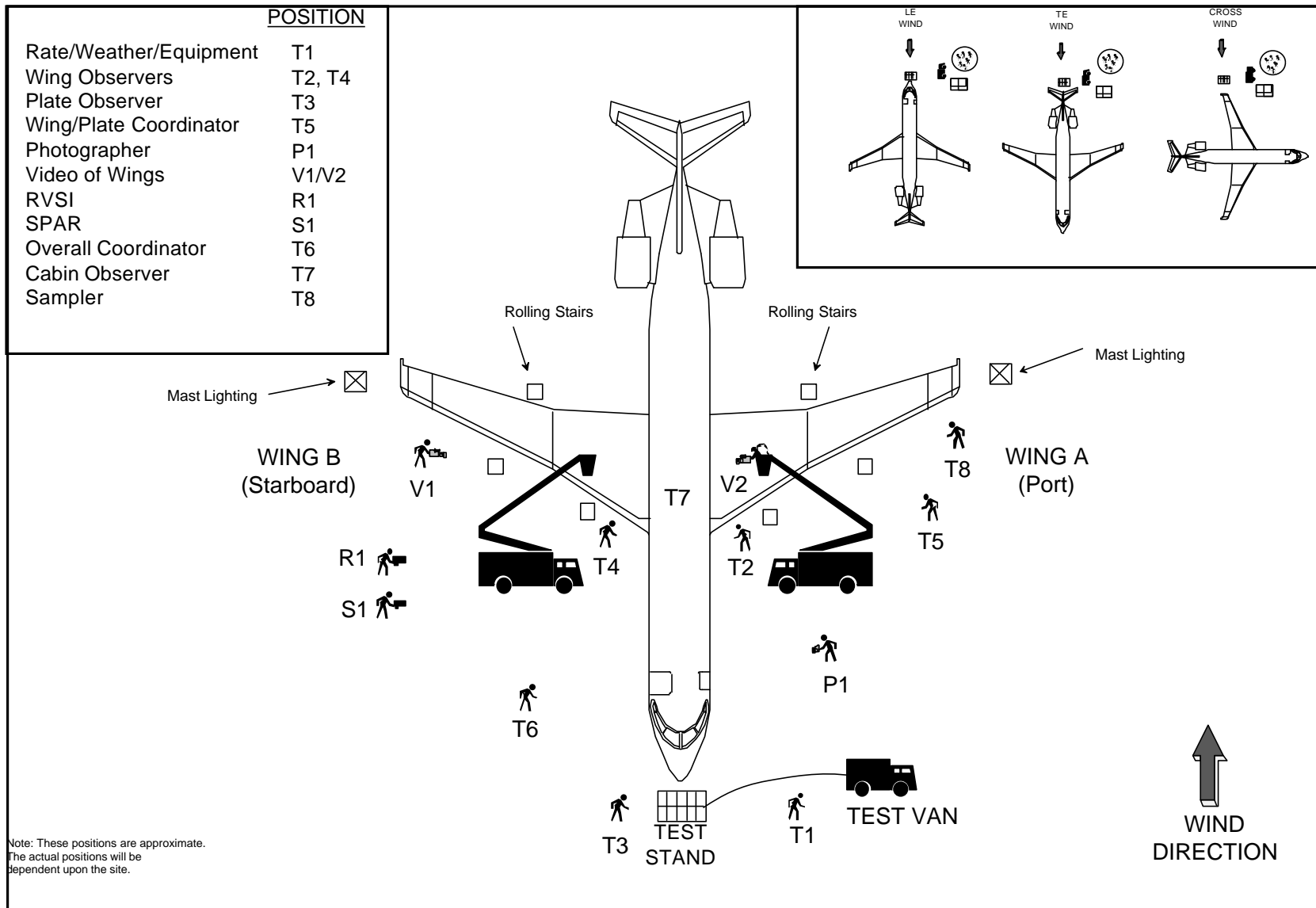

FIGURE 2.3
POSITION OF EQUIPMENT AND PERSONNEL



tests it was mounted on a mechanical lift or the basket of a cherry picker-equipped vehicle.

Two video cameras, a 35 mm still camera, and a digital still camera were used to record fluid failures on wings and plates. Preparations were also in place to rent a digital video camera, as needed, for the documentation of selected tests.

VHF radios were rented to allow communication between co-ordinators and video personnel. Meteorological data, such as temperature, wind speed, and wind direction, were provided by the Remote Environmental Automatic Data Acquisition Concept (READAC), which is located within a very short distance of the central deicing facility at Dorval Airport. (Refer to TDC holdover time reports for complete descriptions of the READAC instruments.)

Wing skin temperatures were recorded using temperature probes mounted on telescopic extension poles. An infrared thermometer was used briefly during the 1997/98 test season and was to be evaluated further in experimental conditions this year. A hand-held anemometer was used to measure local wind speed. A complete list of test equipment used for the Dorval aircraft full-scale test program is given in Appendix B, Attachment III, *Test Equipment Checklist*.

2.1.4 Description of Test Procedures

The APS document *Experimental Program for Full-Scale Fluid Failure Testing* is provided in Appendix B. It describes the detailed procedures to be employed during the course of full-scale testing.

APS monitored weather forecasts on an ongoing basis throughout the test season to anticipate conditions that would require aircraft deicing. If these conditions were forecast, the test team was alerted 48 hours prior to the predicted event. Confirmation of the freezing precipitation event was proceeded by contacting airlines to secure a test aircraft. Arrangements were then made with Aéromag for use of the deicing facility and for spray equipment and personnel. Test equipment, including trucks, mast-lights, and generators were rented. Transport Canada and other companies working in conjunction with APS Aviation, were then notified.

Fluids for full-scale flat plate tests were prepared and stocked in pre-marked red polyethylene fuel containers at the APS test site. The Type IV fluids were stored outdoors at ambient temperature, while the Type I fluids were stored inside the APS trailer. All prepared test fluids were transported to the full-scale test site with the equipment necessary for

testing. The fluids were poured directly from these containers to flat plates. The standard flat plate test one-step fluid application procedure was used.

Fluid samples were to be collected by the APS fluid sampling team on an ongoing basis during tests at the location of first wing failure and at various points of failure on the wing thereafter (as indicated by the wing observer). The fluid sample concentrations were measured directly using a hand-held Brix-scale refractometer and both the fluid sample time and the location in which the sample was taken were recorded immediately. The sampling procedure is contained in Appendix B, Attachment VI.

Several modifications were made in recent years to the plate pan precipitation rate data collection procedure. The start and end times of the rate collection period were to be recorded in hours, minutes, and seconds rather than rounded off to the nearest whole minute. Also, a few seconds were added or subtracted from the rate collection start and end times for time delays created by entering and exiting the truck. Finally, any precipitation that accumulated on the lips, sides, and bottoms of the plate pans was to be removed prior to the weighing of the pans.

A procedure was developed to collect precipitation rate data in aircraft tests conducted in crosswind conditions. In these cases, rates were to be measured on aircraft wings as well as on the test stand. One plate pan mounted on suction cups was to be placed on each wing (mid-section). Plate pans were to be weighed following complete wing failure for Type I fluid tests. For two-step (Type IV over Type I) fluid tests, rates were measured every 15 minutes following application, and directly following complete wing failure. The complete rate collection procedure appears on pages 39 and 40 in Appendix B.

In the past, the time and precise location of first failure were occasionally missed by the wing observer. This is due to the rapid onset and propagation of failures, especially in the case of Type I fluids. In certain tests, failures progressed so rapidly, they reached the 25 percent level by the time the first failure contour was recorded. Procedures were altered to emphasize the requirement to identify the precise location of first wing failure. In tests where rapid failure progression is to be expected, additional observers would be assigned from the test team to assist the wing observer in failure detection.

Pilots were to be present during full-scale test sessions to record their observations of fluid failure and failure progression from inside the cabin and cockpit. This data would later be correlated with the data recorded by the external observers. The pilot observation procedures appear on pages

41 and 42 in Appendix B. Also included in Appendix B are the two data forms to be filled out by the pilot (pages 43 and 44).

Ice detection sensors were to be provided by BFG Aerospace (formerly RVSI) and/or Spar/Cox. The procedure for use of the BFG unit is provided in Appendix B. At the time of initial fluid application, the instrument operator was instructed to scan and capture an image of the tail identification number of the aircraft in order to mark the start of the holdover time period. The grid structure, as illustrated on page 37 of Appendix B, was used to determine the order of images taken by the operator. An entire series of images covering the wing was to be performed every 15 minutes. At the end of the test, the instrument operator was instructed to scan and capture the tail identification number again, to signify the end of the record for that test.

2.1.5 Data Forms

Several different data forms were produced for full-scale testing in 1998/99.

The *General Form – every test* – (see Appendix B, Figure 3, page 47) was completed by the plate/wing co-ordinator and was used to record information such as the type, temperature and quantity of fluid sprayed, as well as the start and end times of the fluid applications.

Another *General Form – once per session* – (see Appendix B, Figure 3a, page 48) was completed by the overall co-ordinator and was used to record information relating to the aircraft, fluids and initial aircraft skin temperatures.

The *Aircraft Wing Form* – (see Appendix B, page 49) shows the form used for fluid failure tests on the Canadair Regional Jet. Similar forms were also produced for the ATR 42 and the de Havilland Dash 8. These forms appear in Appendix B. Wing observers were assigned to identify fluid failures and draw failure contours on the wing diagrams.

The fourth data form is the *Fluid Thickness on Aircraft Form* and is shown on page 55 of Appendix B. This form was to be filled out by the individuals assigned to perform thickness measurements during test events when snow or freezing precipitation had ceased, or during dry runs. The fifth data form is *Fluid Thickness on Flat Plates Form*, shown on page 56 of Appendix B. This form was to be used to record fluid thickness measurements on flat plates during full-scale aircraft tests.

The *End Condition Data Form* – (see Appendix B, Table 1, page 57) was to be completed by the end condition tester. This form is used to record information related to fluid failure times on the flat plates. The *Meteo/Plate Pan Data Form* – (see Appendix B, Table 2, page 58) is completed by the meteo/equipment tester and was to be used to record information on weather conditions and rates of precipitation.

2.1.6 Fluids

The Type I and Type IV fluids required for full-scale testing were provided by Union Carbide. Union Carbide Type I ADF was to be applied in standard concentration (XL54), and Type IV Ultra+ was to be applied in its neat concentration.

2.1.7 Personnel

Personnel requirements for full-scale aircraft tests are considerable. Figure 2.3 provides a schematic description of the general test set-up, as well as the standby location of each member of the full-scale test team. All personnel were involved in the set-up and tear-down of equipment prior to and following tests. The primary roles and responsibilities of each personnel member are listed below:

- **Rate/Weather/Equipment (T1):** Responsible for monitoring meteorological equipment and for recording all weather and precipitation rate data;
- **Wing Observers (T2, T4):** Responsible for drawing failure contours as they occur on wing surfaces;
- **Plate Observer (T3):** Responsible for the execution of flat plate holdover time tests during full-scale aircraft tests;
- **Wing/Plate Co-ordinator (T5):** Responsible for ensuring consistency between wing and plate failure calls;
- **Photographer (P1):** Responsible for taking photographs of important events during each test;
- **Video Recorder (V1, V2):** Responsible for taking video recordings of aircraft wings, with particular attention on fluid contamination, failure initiation and progression;

- **BFG Aerospace and Spar/Cox (R1, S1):** Responsible for taking sensor images of fluids undergoing failure on aircraft wings;
- **Overall Co-ordinator (T6):** Responsible for co-ordinating all aspects of the full-scale tests. The overall co-ordinator is also responsible for safety awareness training (based on guidelines that appear in Attachment VI of Appendix B) and ensuring that safety measures are being respected during the course of full-scale testing;
- **Cabin Observer (T7):** Responsible for observations of fluid treated surfaces and the recording of failures from inside the aircraft; and
- **Sampler (T8):** Responsible for the collection of fluid samples at selected points of failure on the wings.

Attachment IV of Appendix B, *The Responsibilities/Duties of Test Personnel* contains full descriptions of test personnel responsibilities, individual duties, and positions.

Airline ground support personnel were to be made available to tow aircraft to and from the deicing facility, and to orient the aircraft between tests. Deicing crews and fluid application equipment were provided by Aéromag 2000 Inc.

2.2 Frost Formation on Aircraft

This subsection describes tests conducted to determine the roughness of frost deposition on the wings of a Canadair Regional Jet.

2.2.1 Test Sites

All frost tests were conducted at Montreal International Airport (Dorval) directly at the gate during overnight periods of active frost.

2.2.2 Test Plan

A total of three test sessions were planned for winter 1998/99, during overnight periods outside of daily operating times. Canadair Regional Jet aircraft (CL-65) were supplied by Air Canada.

Schematics and views of the CL-65 appear in Appendix B.

2.2.3 Equipment

A ruler with a millimetre scale, as well as American quarters were used to measure the frost deposition. A 35 mm camera was required for documentation purposes.

2.2.4 Description of Test Procedures

The complete procedure for frost tests on the Canadair Regional Jet aircraft is included in Attachment XI in Appendix B.

Each wing was initially broken up into seven sections. Each section was assigned a colour. The index of colours for photos of frost on aircraft wings is shown in Figure 2.4. The American quarters were painted according to the wing section colours, and were designated with an A or B, indicating the port (A) or starboard (B) wing (see Photo 2.8).

When the point of initial frost contamination was determined by the wing observer, an unpainted coin (bearing an A or B) was placed at this location and photographed three times:

1. Overall photograph of the coin relative to the rest of the wing;
2. Macro profile view of the coin to determine the height, shape, and size of surrounding crystals; and
3. Macro plan view of the coin to determine the roughness and texture of surrounding crystals relative to the coin.

When contamination occurred elsewhere on the wing, the colour-designated coins were placed onto the corresponding wing section and photographed in the manner described above. A final set of photographs was taken at the end of each test.

The progression of frost contamination on the aircraft wing is recorded by the wing observer as it occurs during the running of a test.

2.2.5 Data Forms

The Canadair Regional Jet Aircraft Wing Forms, shown on pages 49 and 50 of Appendix B, were used to record drawings of the progression of frost contamination.

2.2.6 Personnel

A wing observer and a photographer were required for these tests.

FIGURE 2.4
INDEX OF COLOURS FOR PHOTOS OF ROUGHNESS ON AIRCRAFT WING

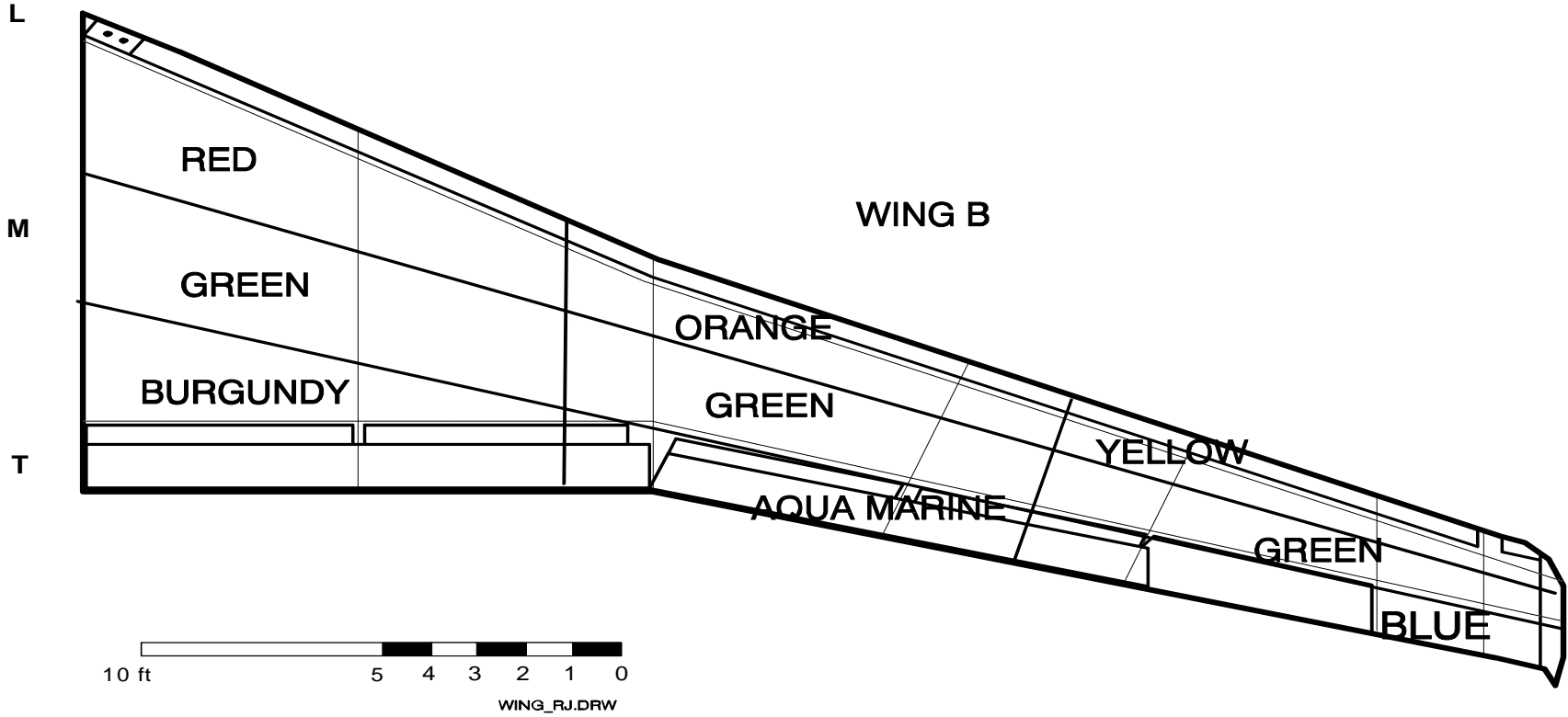

Photo 2.1
Precipitation Rate Measurement Equipment

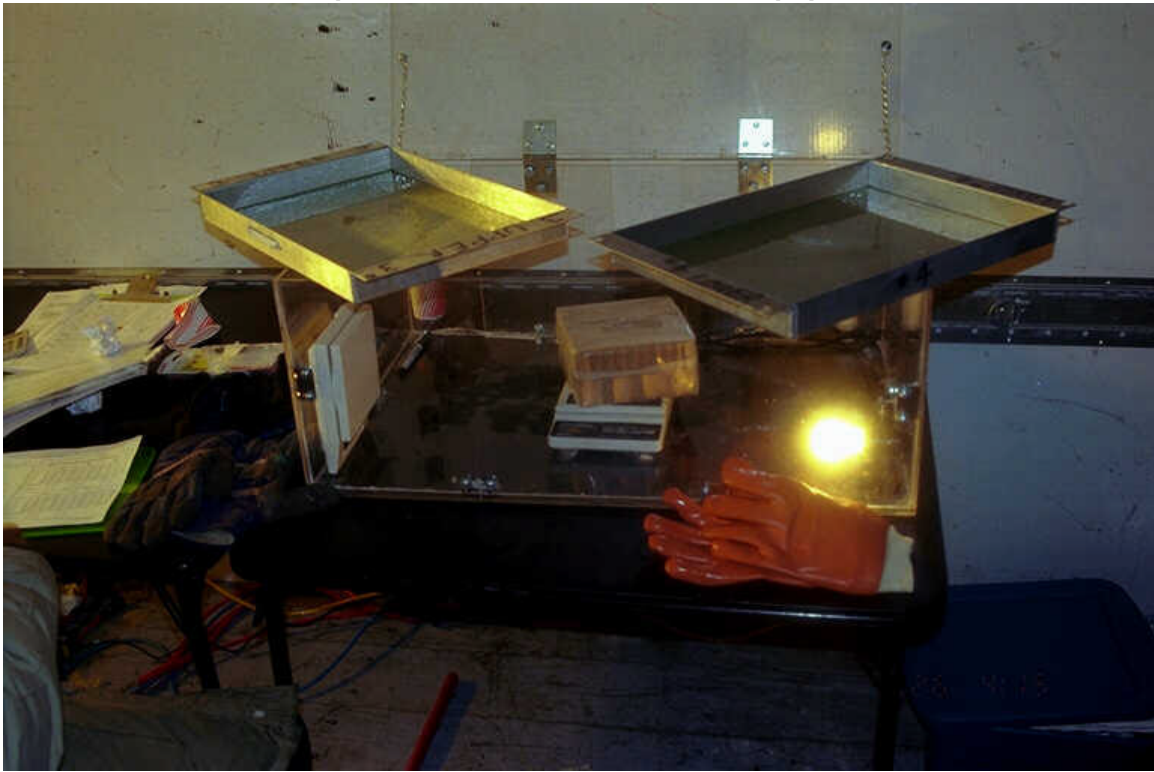

Photo 2.2
Field Lab for Full-Scale Tests



Photo 2.3
Rolling Stairs and Step Ladders Used in Full-Scale Aircraft Trials



Photo 2.4
Mast-lighting Used for Aircraft Illumination



Photo 2.5
Misco Refractometer



Photo 2.6
Hand-Held Ice Detection Sensor by RVSI ID-1H



Photo 2.7
Spar/Cox Sensor



Photo 2.8
Painted Coins Used in Documentation of Roughness of Frost Formation



3. DESCRIPTION AND PROCESSING OF DATA

3.1 Fluid Failure Tests on Operational Aircraft

3.1.1 Overview of Test Sessions

A dry run was conducted during the evening of December 9, 1998, to train personnel and evaluate test procedures. For this purpose, aircraft surfaces were simulated using flat plates. Because no precipitation was present and no aircraft were used in simulations, no useable data were gathered.

Despite the substantial groundwork that had been undertaken to organize full-scale test sessions, including the preparation of test procedures, the hiring and training of test personnel, and the organization of test equipment, all attempts to obtain aircraft for full-scale fluid failure tests in winter 1998/99 failed. The lack of testing reinforces the need for the implementation of a wing test bed and deicing test site, as discussed in a separate report (TP 13487E) (1).

3.2 Frost Formation on Aircraft

3.2.1 Description of the Canadair Regional Jet Wing

The wing of the Canadair Regional Jet is of all-aluminum construction, and contains two flap sections, as well as four spoilers and an aileron. The leading edge of the wing does not contain moveable sections, and consists of highly polished unpainted aluminum. All wing sections, other than the leading edge, were painted white.

For clarity, the terminology employed in this report for describing the various RJ wing sections is shown on the wing plan form in Figure 3.1.

3.2.2 Overview of Test Sessions

Frost tests were conducted on Canadair Regional Jet aircraft during three separate overnight periods. The general summary of the test conditions for each night appears in Table 3.1.

Test ID #1 was conducted during the early morning hours of December 5, 1998. The aircraft had been exposed to active frost conditions since it had arrived at the airport, nearly three hours prior to the start of testing.

FIGURE 3.1
REGIONAL JET WING SECTIONS

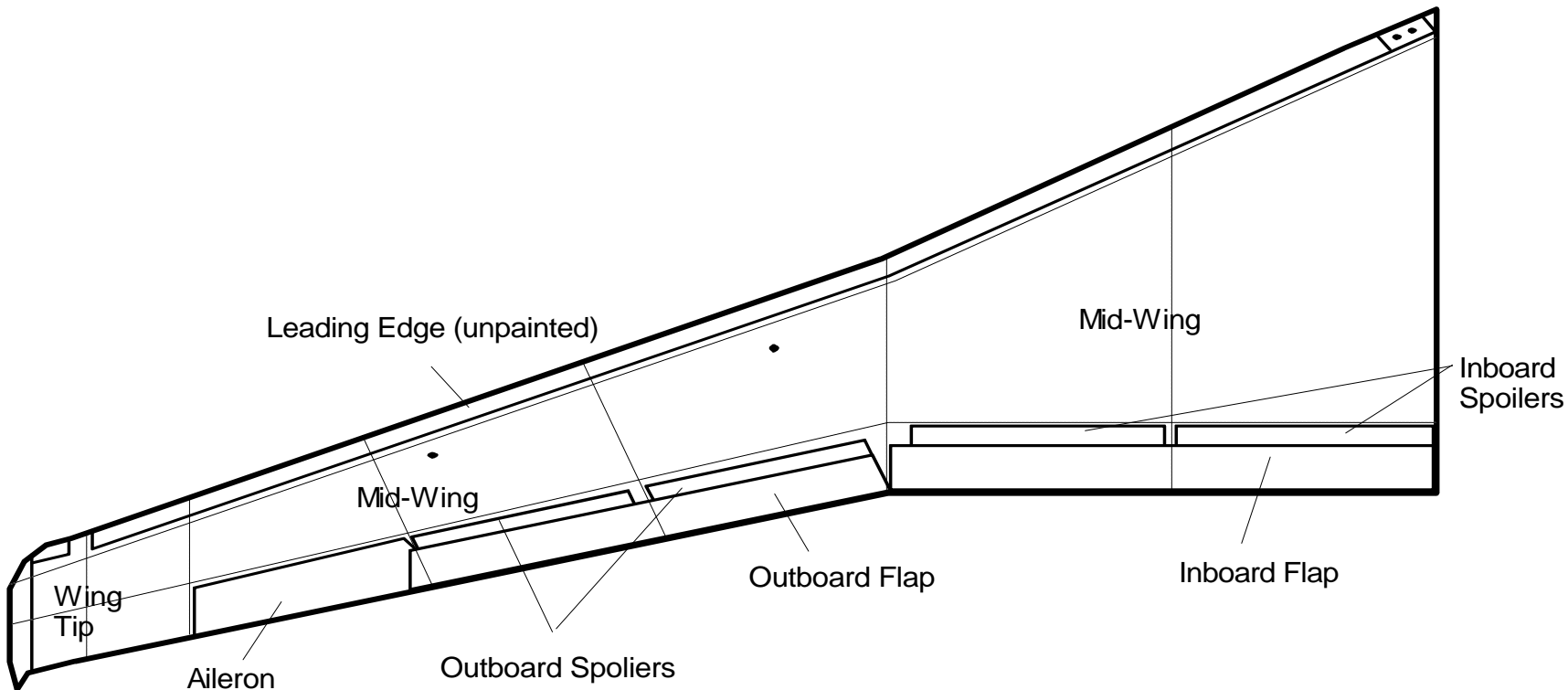

Table 3.1

GENERAL SUMMARY OF TEST CONDITIONS

Date	Average Temperature	Average Wind Speed	Average Dew Point	Average RH	Sky Condition
Dec. 5, 1998	-2°C	5 km NNE	-4°C	77%	Clear
Dec. 8, 1998	-4°C	6 km NNE	-7°C	78%	Clear
Feb. 15, 1999	-11°C	6 km SW	-15°C	80%	Clear

Heavy frost accumulation was present on both wings at the start of testing at 4 AM.

Test ID #2 was conducted on December 8, 1998, following a series of frost deposition tests on flat plates at the Dorval Airport test facility. As a result, the aircraft had been exposed to active frost conditions for nearly four hours prior to the first photographs taken by APS personnel at 3 AM.

The rates of frost deposition during the overnight test period, computed based on the results of flat plate trials, ranged from 0.05 to 0.09 g/dm²/h for painted aluminum surfaces. No frost deposition was observed on bare aluminum surfaces.

Test ID #3 was conducted during the night of February 15, 1999. In order to capture the onset of frost deposition on the RJ aircraft, APS personnel were on stand-by and the test equipment was set up prior to the arrival of the RJ aircraft at the gate. APS personnel were informed shortly after the unloading of passengers that the aircraft required overnight maintenance, and would not be available for testing. Since several aircraft of this type overnight at Dorval Airport, another RJ aircraft was selected by the APS test team. Upon arrival at the new gate, a light frost was observed on the wings of the aircraft to be tested.

Frost deposition rates were again computed for this overnight test period in flat plate trials conducted at the APS Dorval test site, and ranged from 0.02 to 0.04 g/dm²/h on painted aluminum surfaces. Once again, no frost was observed on bare aluminum test panels. The test set-up for flat plate trials in frost conditions is shown in Photo 3.1.

Figure 3.2 shows some of the test parameters collected during flat plate trials on February 15, 1999. The active frost period began at approximately 1:30 AM, when the surface temperature of the painted aluminum plate was equal to or below that of the dew point temperature. Active frost continued until just prior to 3:30 AM. The aircraft frost test began at 2:40 AM, and a light frost was present on the wings at this time.

In Tests ID#1 and ID#2, the CL-65 aircraft used in testing was located in a well lit area in close proximity to the Dorval Airport terminal building (within 30 feet). In Test ID#3, the aircraft was located in a more isolated area on the west side of the airport. The aircraft in Test ID#3 was positioned approximately 50 feet from the terminal building.

The average density of frost peaks per square centimetre in each of the wing sections was also calculated using the transparent grid.

FIGURE 3.2
Meteorological Profile of Test Session
February 14-15

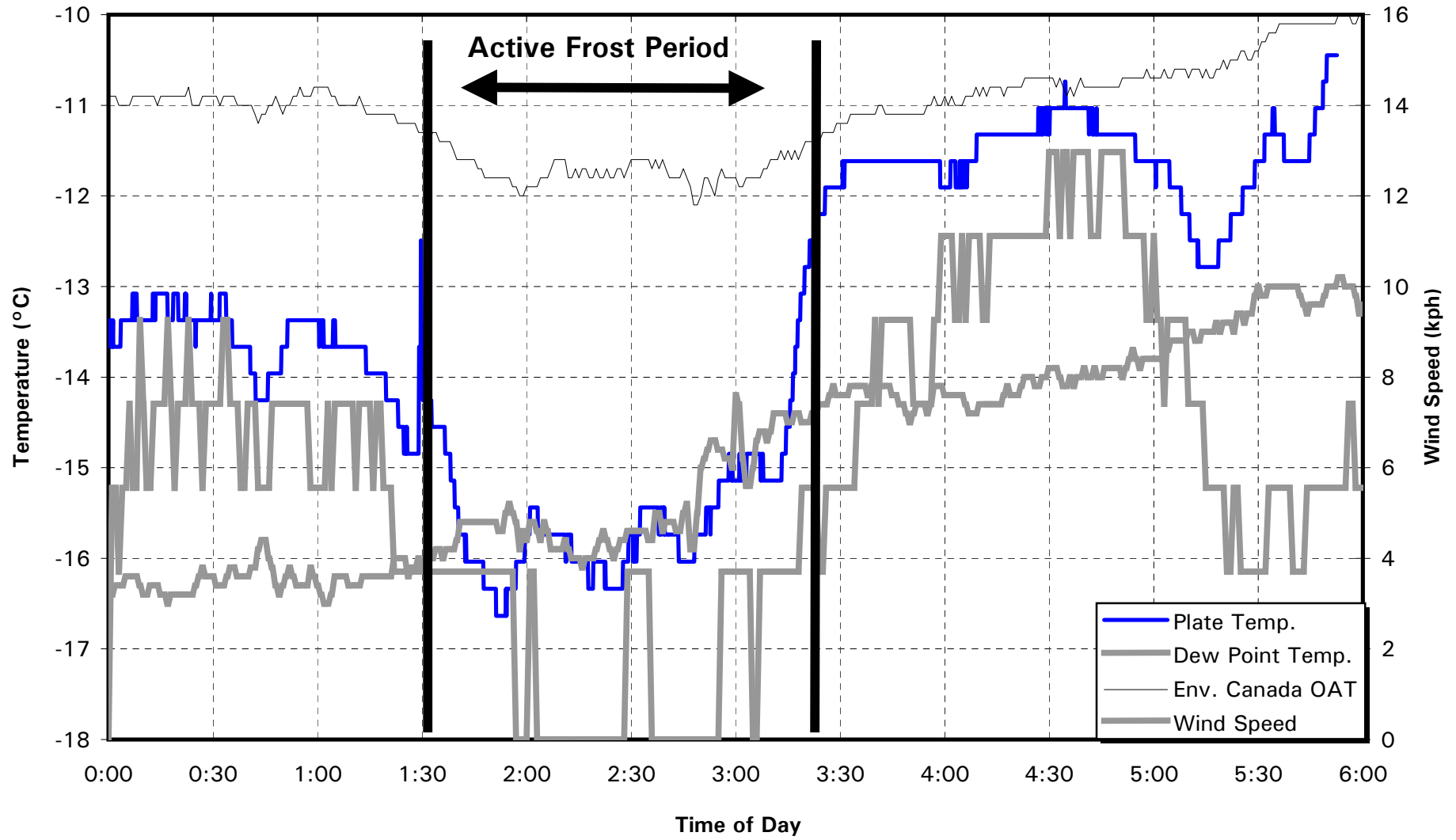

3.2.3 Description and Reduction of the Data

This section provides the raw data collected for each test, as well as a description of the methodologies used to analyse the data.

3.2.3.1 Mapping of Frost Deposition

The frost deposition present on the wings of the Canadair Regional Jet aircraft prior to the beginning of each test period was *mapped* by the wing observer onto a plan view of the wing. A scanned example of the hand-drawn pattern is shown in Figure 3.3.

3.2.3.2 Frost Distribution in Plan Form

The size (diameter) of individual frost formations and the percentage of the test surface area covered with frost deposits versus the percentage uncovered were taken as parameters of interest.

A sampling approach utilizing a transparency of an indexed grid overlaid on the photo was followed. In this approach, the transparent grid was overlaid on the photos from each wing section, and frost formations were traced onto the grid.

The dimensions of the frost formations were then calculated by superimposing the transparent grid (with frost formations traced on it) over millimetre-paper or the millimetre-scale ruler shown in each photograph. An example of a photograph used to determine frost formation dimensions, along with its transparent grid, is shown in Figure 3.4.

The transparent grid was also used to measure the surface area covered by frost on each wing section. Each grid square consists of 100 smaller squares. Each small square within a larger grid square was examined for the presence of frost, and the estimated value representing the percentage of frost present in the selected small square was assigned. The surface area covered by frost in each of the larger grid squares was then calculated by adding the number of smaller squares containing frost. For example, in Figure 3.4, grid square 1-A had 26 out of 100 smaller squares partially covered with frost. The percentages of frost coverage in each of the smaller squares were added up and totalled 10 full small squares of frost, which translates to 10 percent frost coverage. Using the same method, grid square 2-B had 14 of 100 smaller squares covered completely with frost, which translates to 14 percent frost coverage. These two values were then averaged in order to determine the frost surface area coverage for the wing section shown in the photograph in Figure 3.4.

FIGURE 3.3
FROST PATTERN ON CL-65 PORT WING (ID # 1)

December 5, 1998 - 4:00 AM

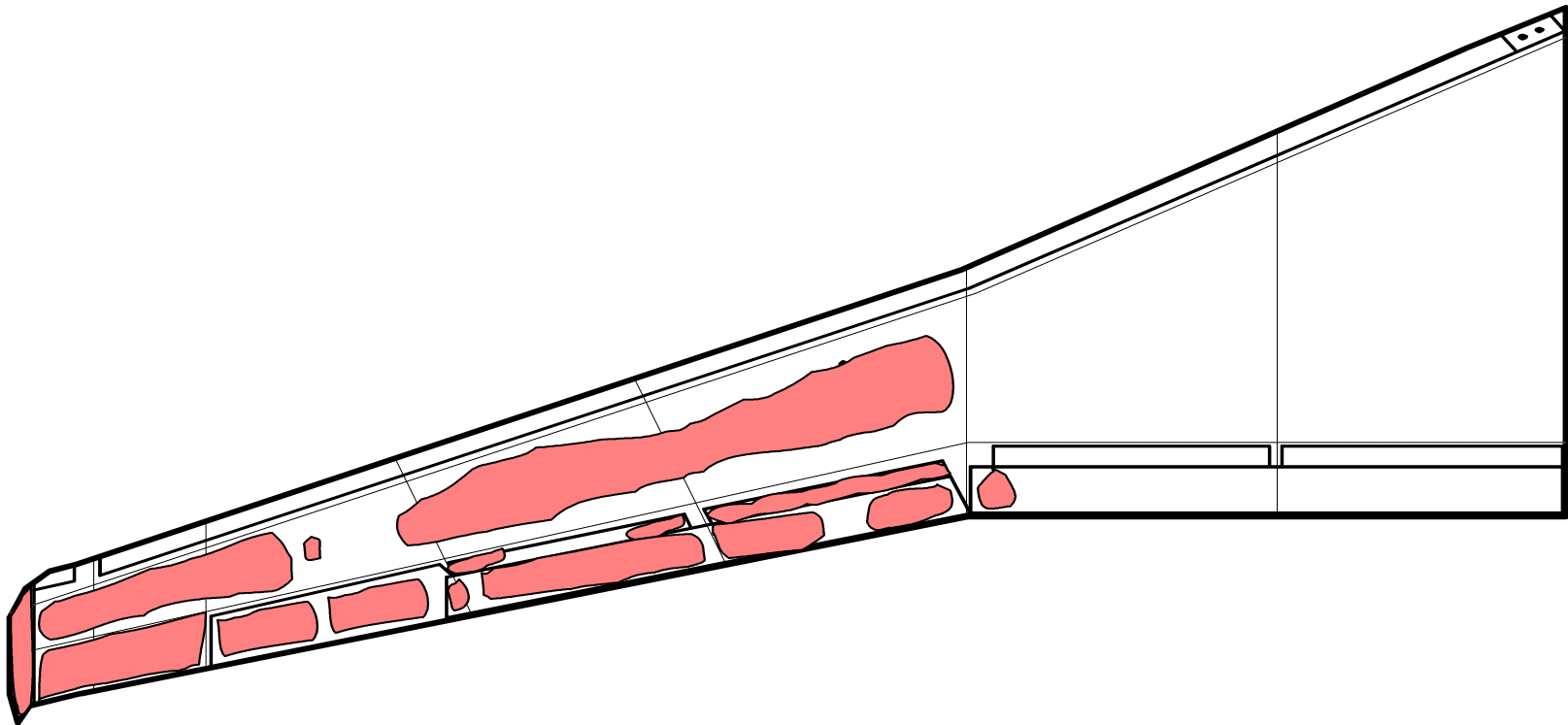
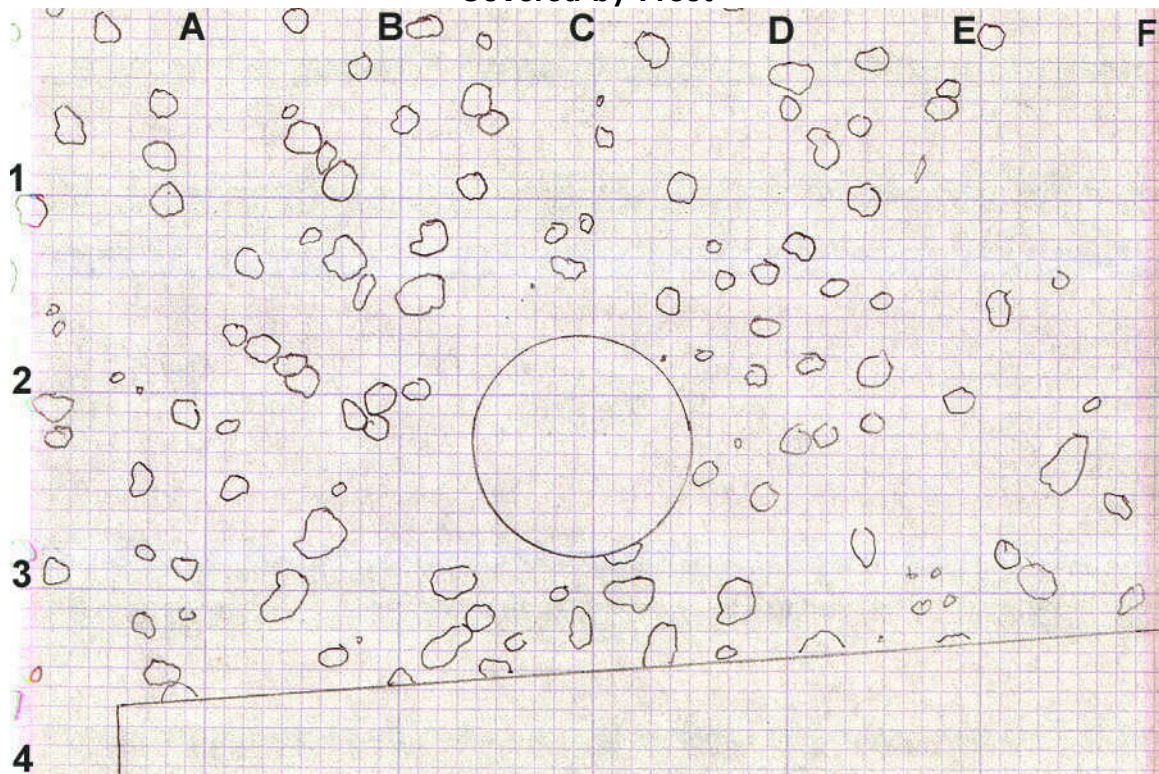

Figure 3.4
Plan Photo of Frost Formation on RJ Aileron



Transparent Grid used to Determine Frost Sizes and Surface Area Covered by Frost



Each large square represents 25.4mm (1 inch).

The average density of frost peaks per square centimetre in each of the wing sections was also calculated using the transparent grid.

3.2.3.3 Frost in Profile

The heights of frost deposits on the surface of the various wing sections were also of interest. They were estimated primarily using the millimetre-scale ruler shown in each profile photograph of the frost deposits. An example of the profile photography (and the ruler used to measure frost heights) is shown in Photo 3.2. In this example, the height of the frost is estimated at 0.5 to 0.8 mm.

This page is intentionally left blank.

Photo 3.1
Test Set-up for Flat Plate Trials in Frost Conditions

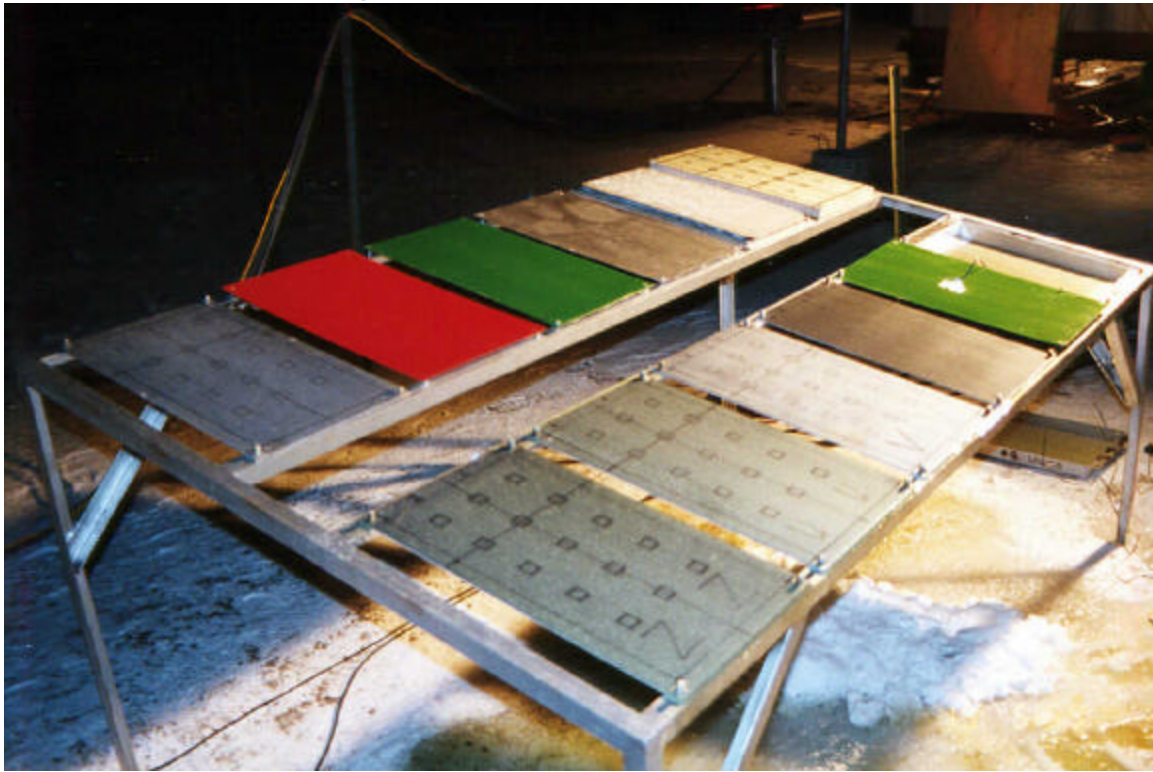
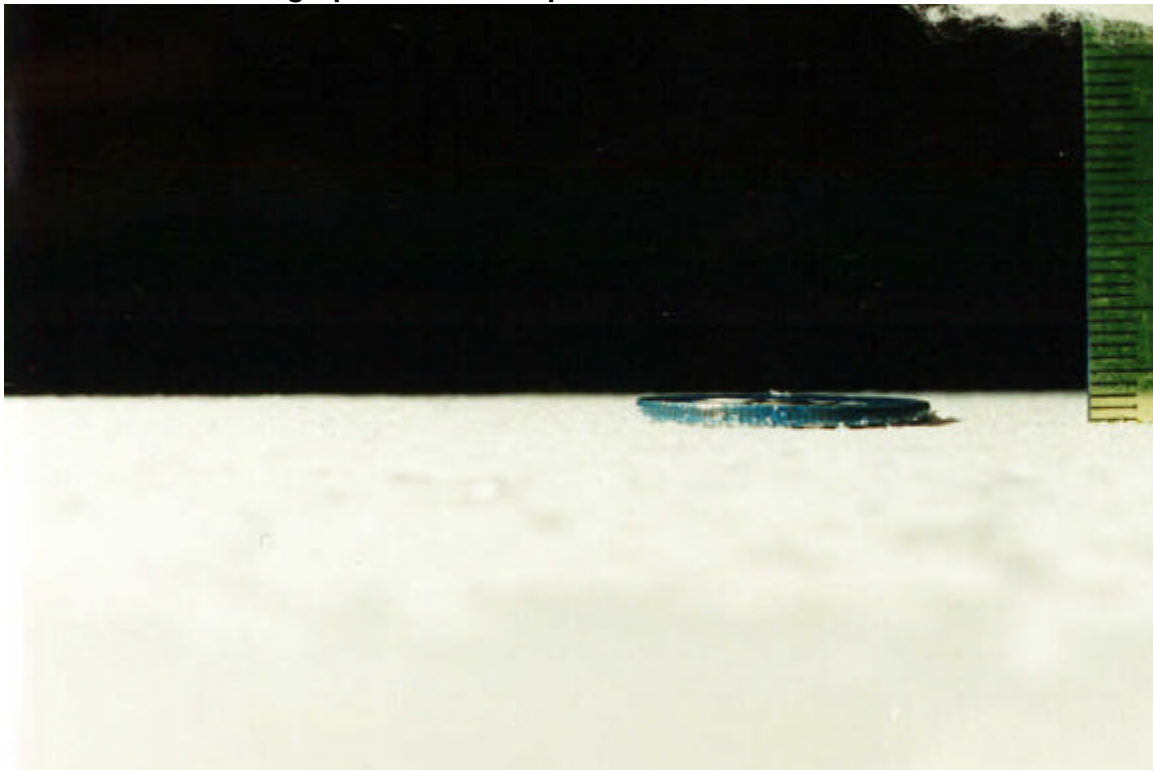

Photo 3.2
Profile Photograph of Frost Deposition and Millimeter-Scale Ruler



4. ANALYSIS AND OBSERVATIONS

4.1 Fluid Failure Tests on Operational Aircraft

No full-scale fluid failure tests were conducted during the 1998/99 winter. Therefore, no full-scale fluid failure data are available for the 1998/99 winter season.

4.2 Frost Formation on Aircraft

4.2.1 Mapping of Frost Patterns

Figures 4.1 and 4.2 show the frost deposits that accumulated on the port and starboard wings of the RJ aircraft prior to the start of testing on December 5, 1998 (ID#1). On both wings, similar patterns of heavy frost were evident (Photos 4.1 and 4.2). Visual inspection revealed that frost accumulation on both wings was heaviest on the wing tip and trailing edge of the wing (outboard of the aileron - see Photo 4.3). Heavy accumulation was also present on the aileron, outboard flap, outboard spoilers, and on the mid-wing sections outboard of the inboard flap section. With the exception of small patches of contamination on the inboard flap, no frost was present on these surfaces. The inboard spoilers, inboard mid-wing sections, as well as the entire leading edges were entirely free of frost (see Photo 4.4).

Figure 4.3 shows the frost deposition pattern on the port wing on the Regional Jet aircraft prior to the onset of testing on December 8, 1998 (ID#2). Since the aircraft had been resting in active frost conditions for 4 hours prior to the onset of testing, heavy frost was present on most wing sections outboard of the inboard wing section (see Photo 4.5). The heaviest accumulation was once again on the wing tip (see Photo 4.6) and the trailing edge outboard of the aileron. No leading edge frost was observed.

On February 15, 1999, APS test personnel were present at the gate at 1:38 AM, awaiting the arrival of the incoming aircraft. Frost patterns were observed to develop less than 15 minutes after the arrival of the aircraft, on the aileron and on the trailing edge outboard of the aileron. It was at this point that APS personnel were informed that the aircraft required overnight maintenance. Figure 4.4 shows the frost patterns on the port wing prior to the departure of the aircraft for the maintenance base. Photo 4.7 also shows this frost development.

FIGURE 4.1
FROST PATTERN ON CL-65 PORT WING (ID # 1)

December 5, 1998 - 4:00 AM

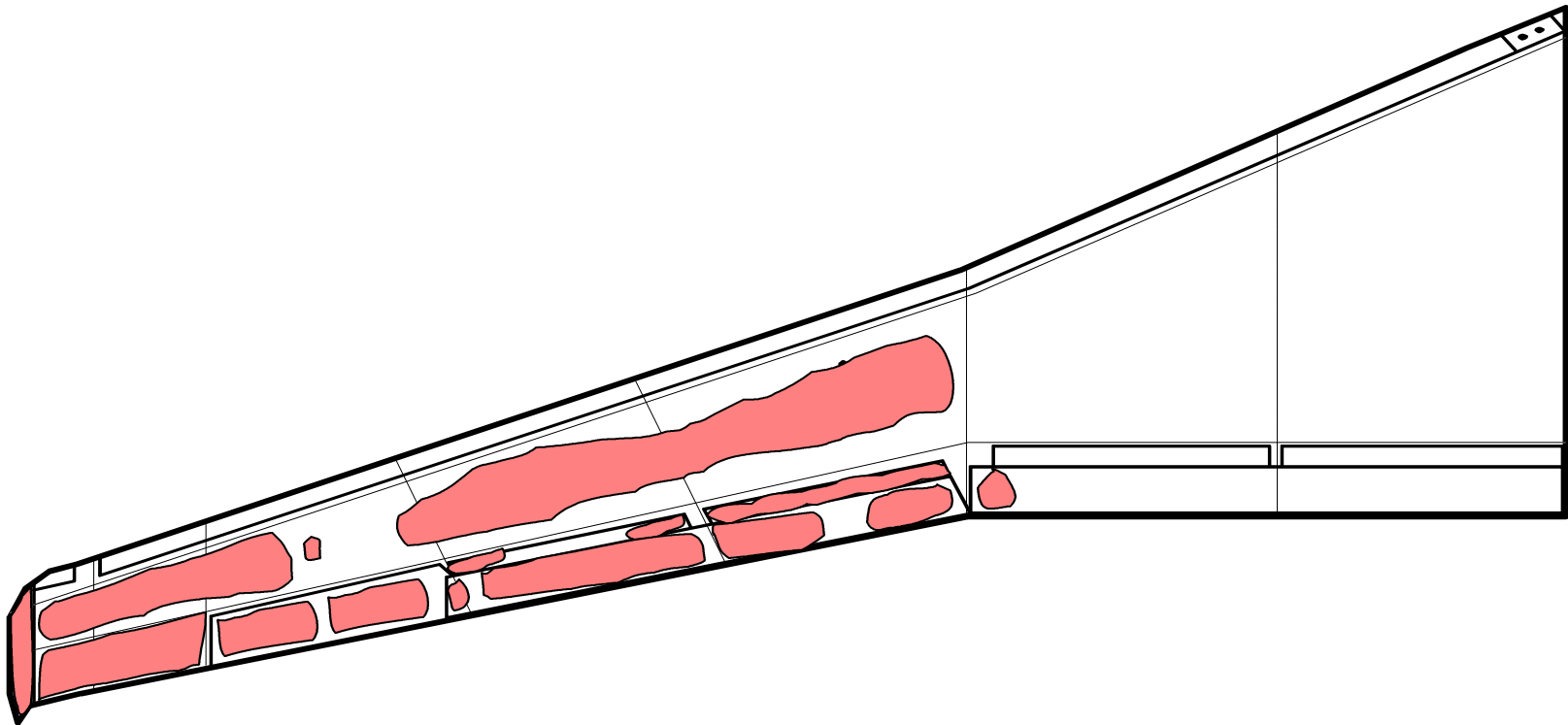

FIGURE 4.2
FROST PATTERN ON CL-65 STARBOARD WING (ID # 1)

December 5, 1998 - 4:00 AM

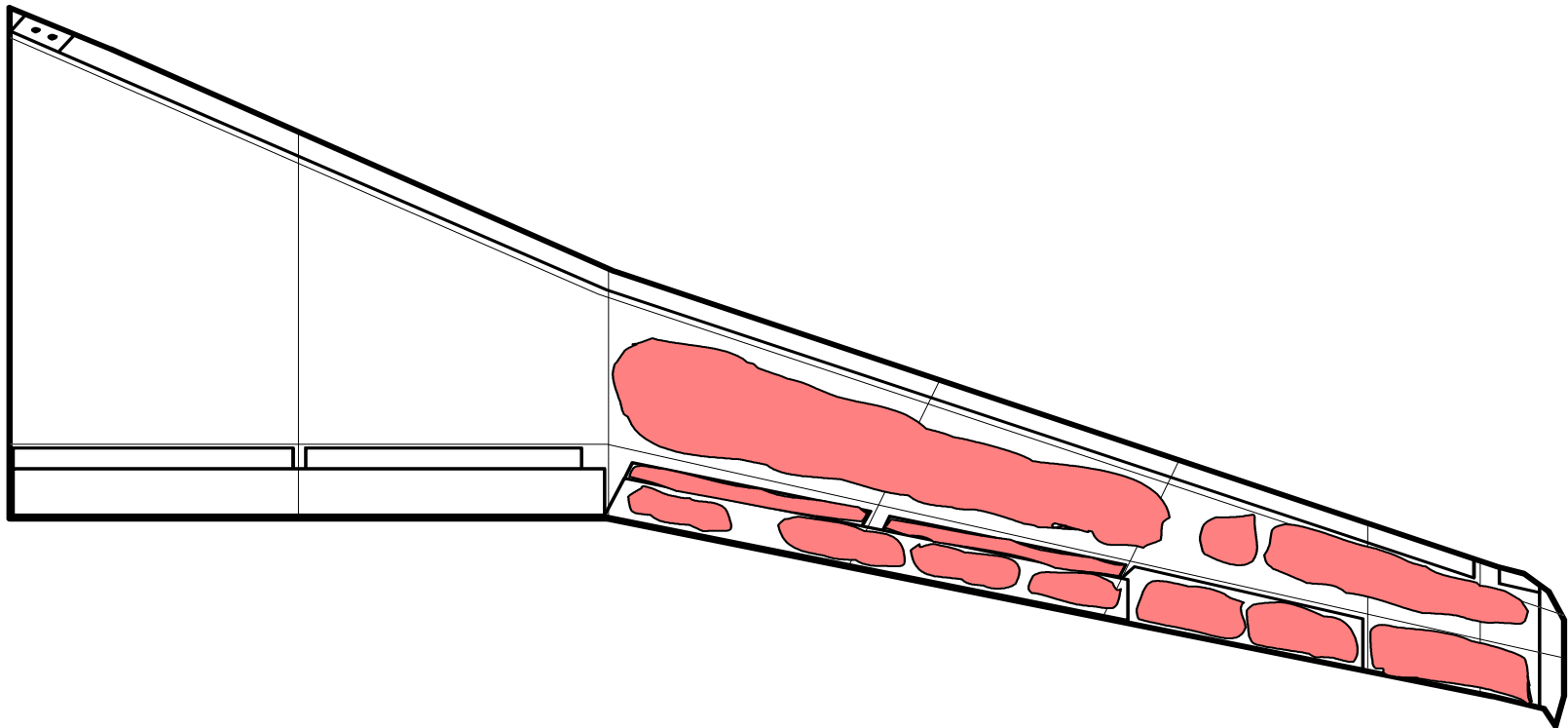

FIGURE 4.3
FROST PATTERN ON CL-65 PORT WING (ID # 2)

December 8, 1998 - 3:00 AM

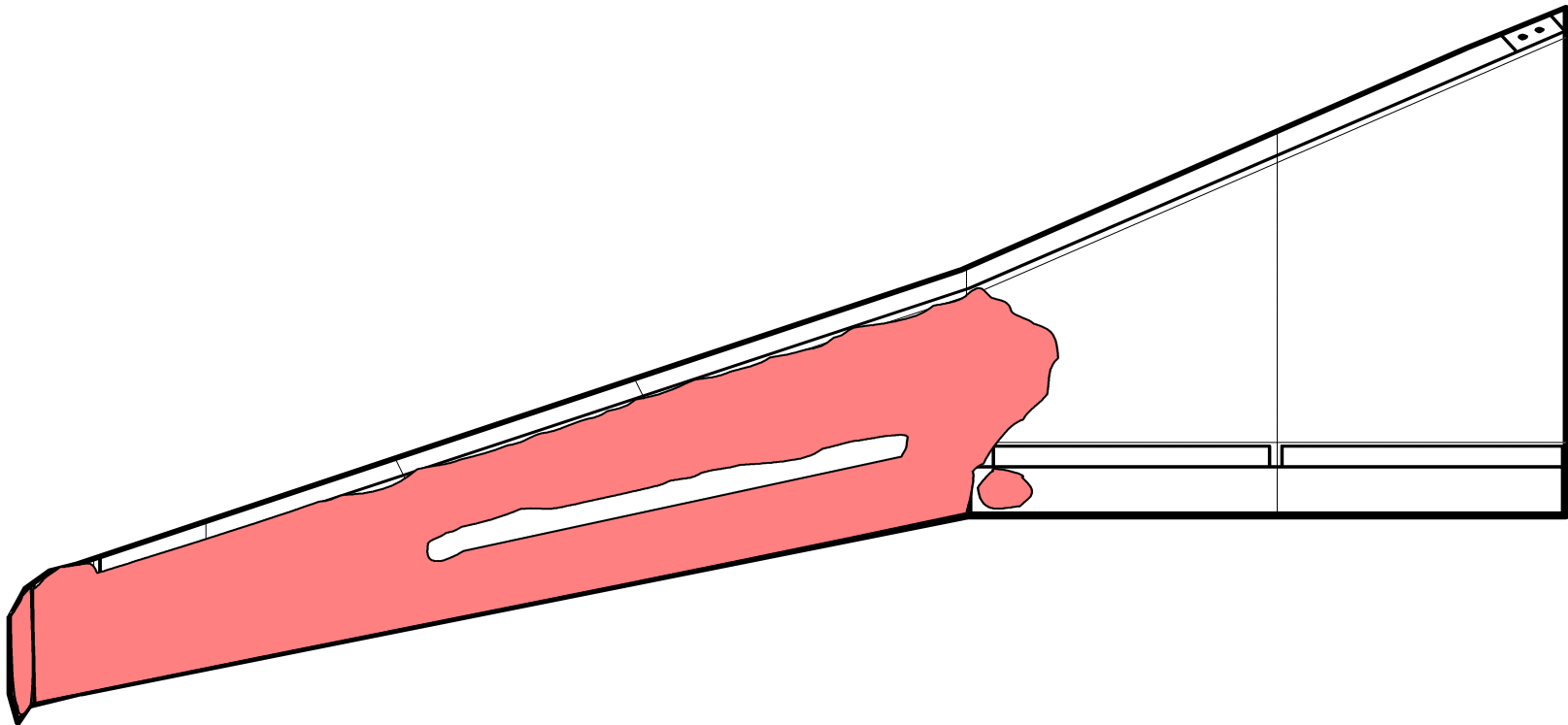
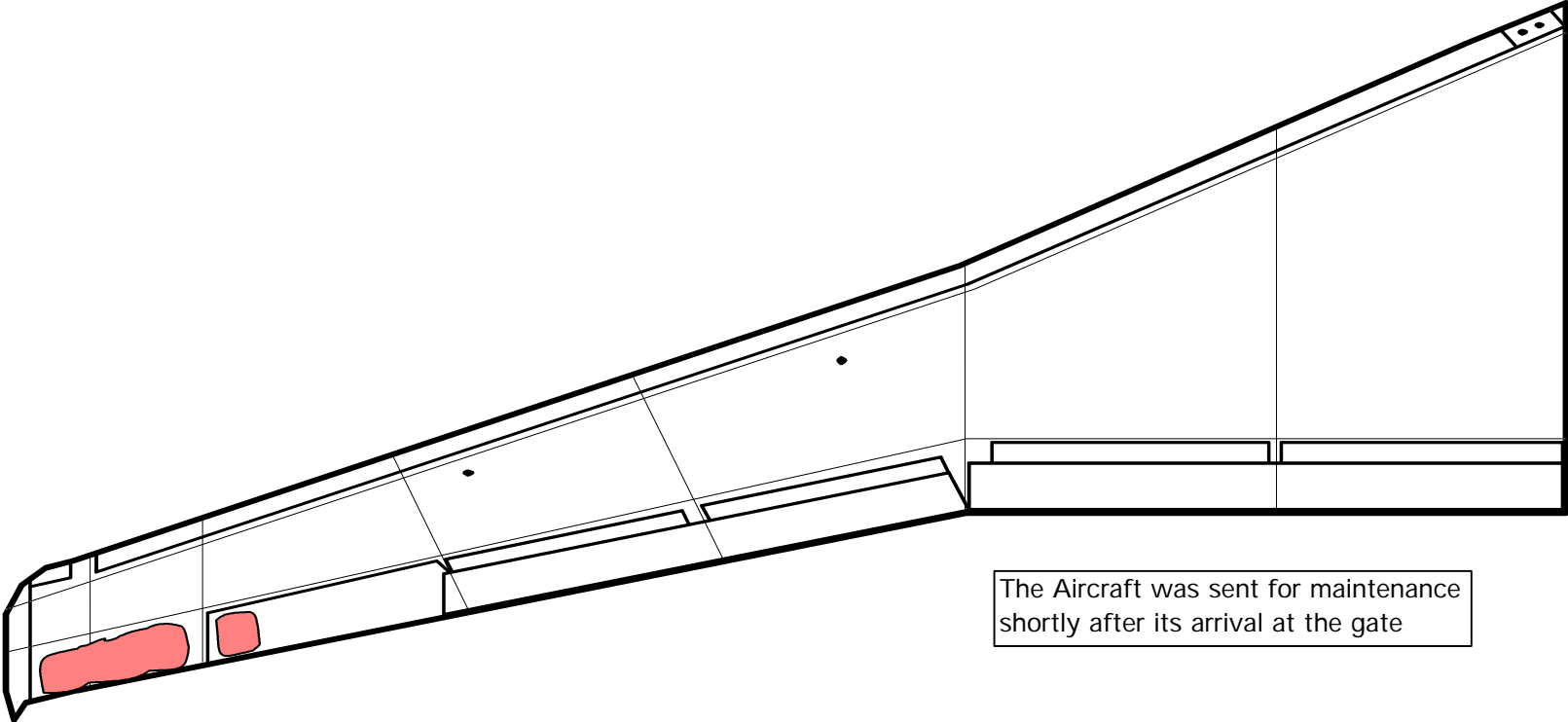

FIGURE 4.4
FROST PATTERN ON CL-65 PORT WING (1:55 AM)

February 15, 1999



The Aircraft was sent for maintenance shortly after its arrival at the gate

Another overnighing aircraft was selected by APS personnel for test purposes on February 15, 1999. The frost development patterns observed during this test (ID#3) are shown in Figure 4.5. A much lighter frost had formed on the wing surface than those observed in the two previous frost tests. Although lighter in deposition, the patterns of development were similar to the previous tests, with the heaviest accumulation on the trailing edge outboard of the aileron (see Photo 4.8). No frost was detected on the leading edge (see Photo 4.9) or on the inboard mid-wing section.

The patterns of frost deposition on the RJ wings in all frost tests were nearly identical, regardless of the rate or duration of overnight frost deposition. Frost initiates on the wing tip, aileron, and trailing edge outboard of the aileron. These wing sections were also observed to contain the heaviest frost formations. Frost also readily accumulates on the outboard flap sections, outboard spoilers, and outboard mid-wing sections. With the exception of small, isolated patches of frost on the inboard flaps and spoilers, no frost was observed to accumulate on these surfaces. The entire leading edge was clear of frost formation in all trials.

These results correlate well with frost deposition trials conducted on flat plates at the Dorval test site. In these trials, various test surfaces were exposed to active frost conditions in order to evaluate the influence of the test surface on the rate of frost deposition. In tests conducted during the 1997/98 winter, frost was observed to form on composite and painted aluminum surfaces, but not on bare polished aluminum surfaces (see TP 13314E). These results were also confirmed in flat plate trials conducted during the concurrent test season. The same behaviour occurs on RJ wing surfaces. The entire wing consists of painted aluminum with the exception of the leading edge, which is bare polished aluminum. Frost was observed to accumulate on the various wing sections, but not on the leading edge.

4.2.2 Frost Distribution in Plan and Profile

Test ID#1 was conducted early in the season primarily to verify test procedures. In Test ID#2, the frost deposition on the wings of the Regional Jet had progressed beyond the desired level of contamination prior to the start of testing. Therefore, only the results of Test ID#3 were used in the determination of frost formation diameter, height, and surface area coverage.

Using the methods outlined in Sections 3.2.3.2 and 3.2.3.3, the diameter, height and surface area coverage of the frost deposits on the various RJ wing sections were estimated, and are shown in Table 4.1.

FIGURE 4.5
FROST PATTERN ON CL-65 PORT WING (ID # 3)

February 15, 1999 - 2:40 AM

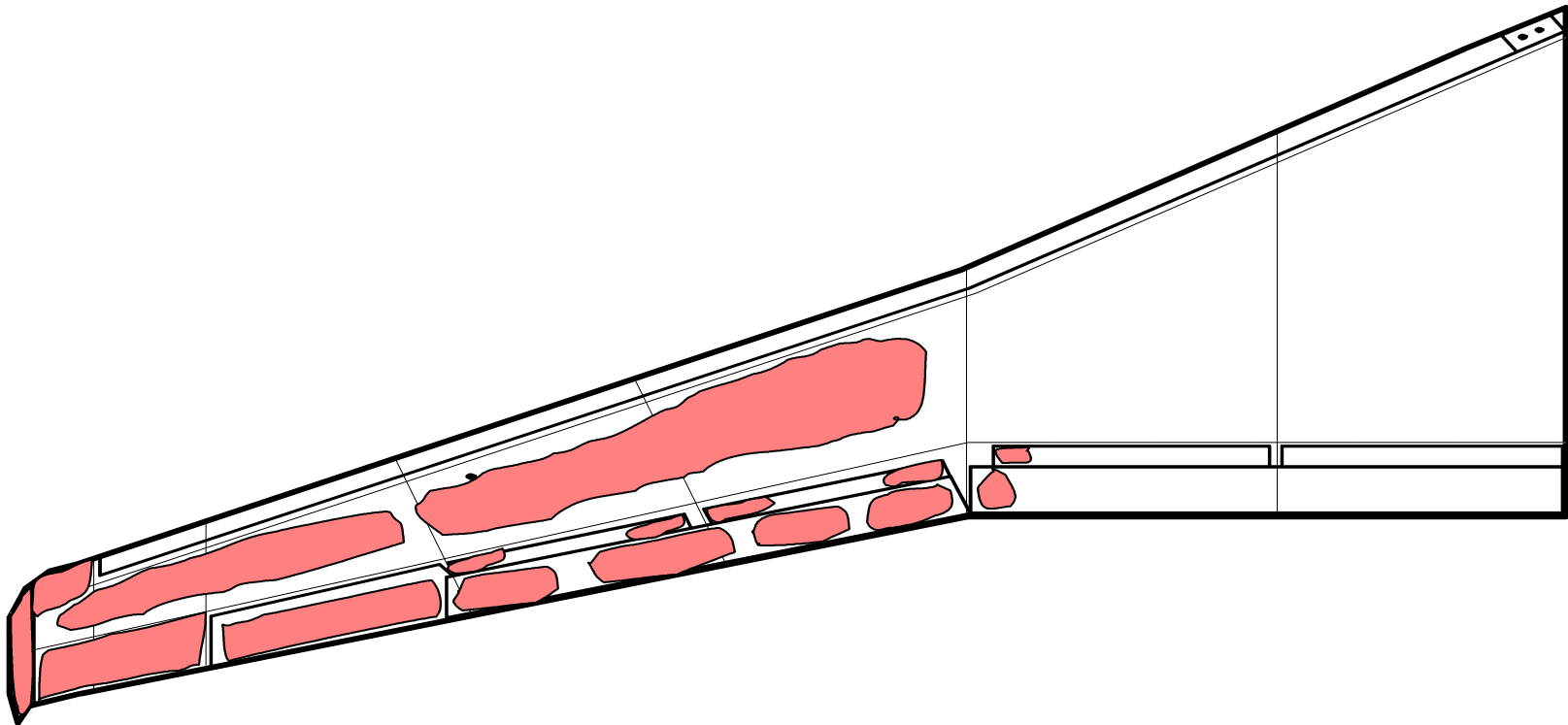
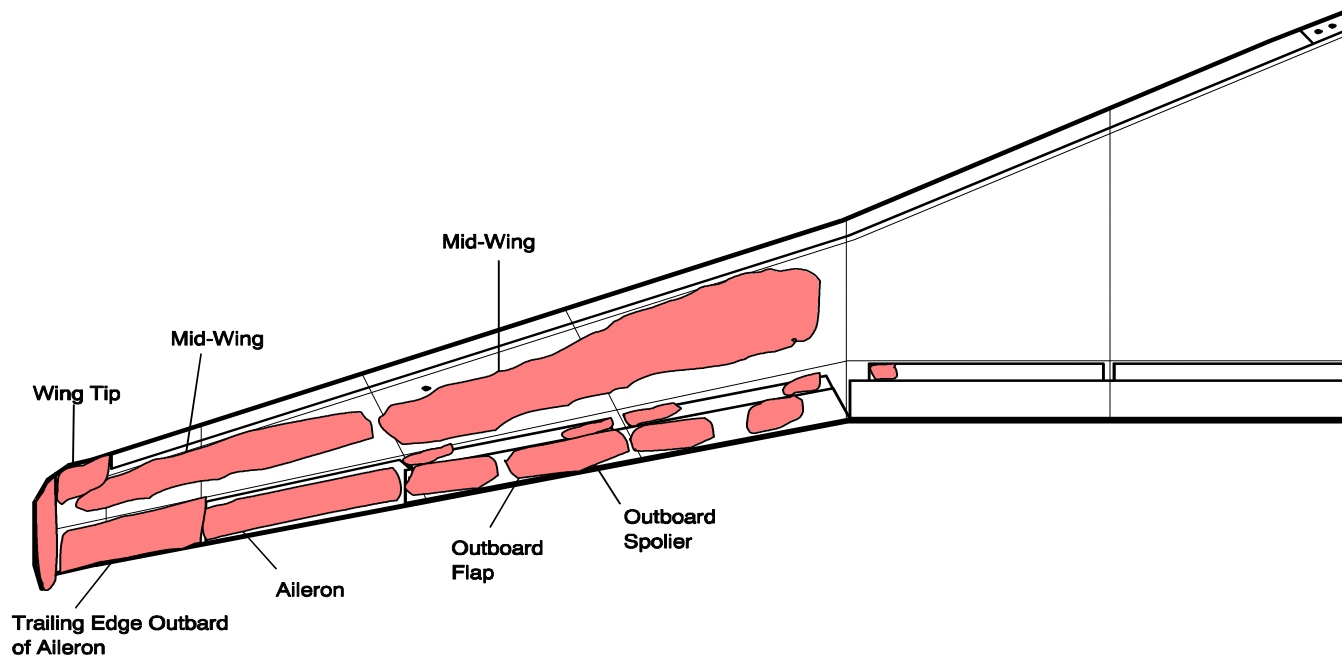

TABLE 4.1
FROST DIAMETER, HEIGHT, SURFACE AREA COVERAGE, AND DENSITY
ON A CL-65 WING (ID # 3)

February 15, 1999



Wing Section	Average Frost Diameter (mm)	Surface Area Covered	Average Frost Height (mm)	Density Peaks/cm ²
Aileron	4	12%	0.2	2
Outboard Spoiler	3	9%	< 0.2	2
Outboard Flap	1	6%	< 0.2	4
Mid-Wing	3	8%	< 0.2	2
Wing Tip	5	80%	0.5	NA
Mid-Wing	3	7%	< 0.2	2
Trailing Edge Outboard of Aileron	> 5	94%	0.5 - 0.8	NA

Photo 4.10 was used in the determination of frost diameter and surface area coverage on the CL-65 aileron. In this case, the average frost diameter was 4 mm and the surface area coverage was 12 percent. Photo 4.11 is an overall shot of the frost formation on the aileron.

The plan and overall photographs of the frost formations on the outboard spoilers are shown in Photos 4.12 and 4.13. The average frost diameter was estimated at 3 mm and covered 9 percent of the total surface area.

Photos 4.14 and 4.15 are plan and overall photos of the outboard flap section. The estimated average frost diameter was 1 mm while the surface area coverage was 6 percent.

Photos of the mid-wing sections are shown in Photos 4.16 and 4.17. The average frost diameter in these wing sections was 3 mm and the surface area coverage was 6-7 percent.

The wing tip (see Photos 4.18 and 4.19) and the trailing edge outboard of the aileron (see Photos 4.20 and 4.21) were the two wing sections with the heaviest frost accumulations. The average frost diameters for these sections were respectively 5 mm and greater than 5 mm, while the average frost surface area coverages were 80 percent and 94 percent.

Frost was not observed to form on the CL-65 polished leading edge in any frost tests (see Photo 4.22).

The values in Table 4.1 confirm the visual observations of frost development, which indicate that frost formation was heaviest on the trailing edge outboard of the aileron, the wing tip, and the aileron itself. In fact, whereas no other wing sections accumulated more than 12 percent frost coverage, the wing tip and trailing edge outboard of the aileron showed 80 percent and 94 percent coverage, respectively. The mean frost diameter and height in these two wing sections were both larger and thicker than those of the other wing sections. Furthermore, due the widespread frost coverage on the trailing edge outboard of the aileron, individual frost deposits were not clearly distinguishable. This is the reason the mean frost diameter for this wing section was estimated at > 5 mm. All other wing sections had similar mean frost diameters, mean frost heights, and surface area coverage.

The density of frost on the aileron, outboard spoiler, and mid-wing sections was 2 peaks/cm². The outboard flap had a density of 4 peaks/cm², although the diameter of the frost deposits was substantially lower than those of the other wing sections. No densities were calculated for the wing tip and trailing edge outboard of the aileron because the individual

peaks of frost were indistinguishable due to the heavy surface area coverage of the frost.

Due to difficulties in measuring heights smaller than 1 mm, the frost height measurements were estimated using the ruler and by comparison with the height of the American 25¢ coin (1.5 mm thick). In future trials, a microscope or macroscope with measurement crosshairs should be employed.

4.2.3 Frost Self-Elimination Using Luminous Radiation

The impact on the temperature of an exposed surface experiencing thermal radiation exchange with the open night sky is further documented in Appendix E.

Photo 4.1
Frost Accumulation on Port Wing (ID# 1)



Photo 4.2
Frost Accumulation on Starboard Wing (ID# 1)



Photo 4.3

Heavy Frost Accumulation on the Aileron and Trailing Edge Outboard of the Aileron of the Starboard Wing (ID# 1)



Photo 4.4

Frost Accumulation on Port Wing (ID# 1)



Photo 4.5
Frost Accumulation on Port Wing (ID# 2)



Photo 4.6
Heavy Frost Accumulation on the Wing Tip (ID# 2)

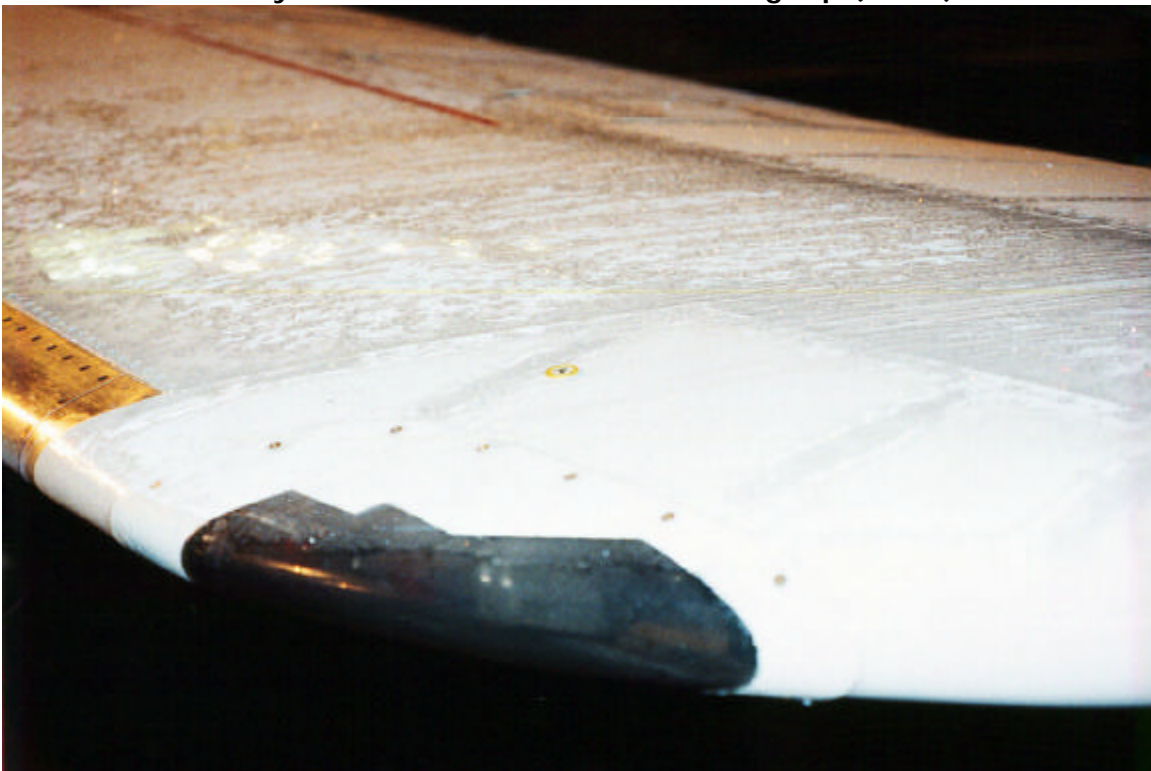

Photo 4.7
Frost Accumulation on Port Wing Shortly After Arrival of Aircraft



Photo 4.8
Frost Accumulation on Port Wing (ID# 3)



Photo 4.9
Frost Accumulation on the Port Wing (ID# 3)



Photo 4.10
Plan Photo of Frost Formation on the Aileron (ID# 3)

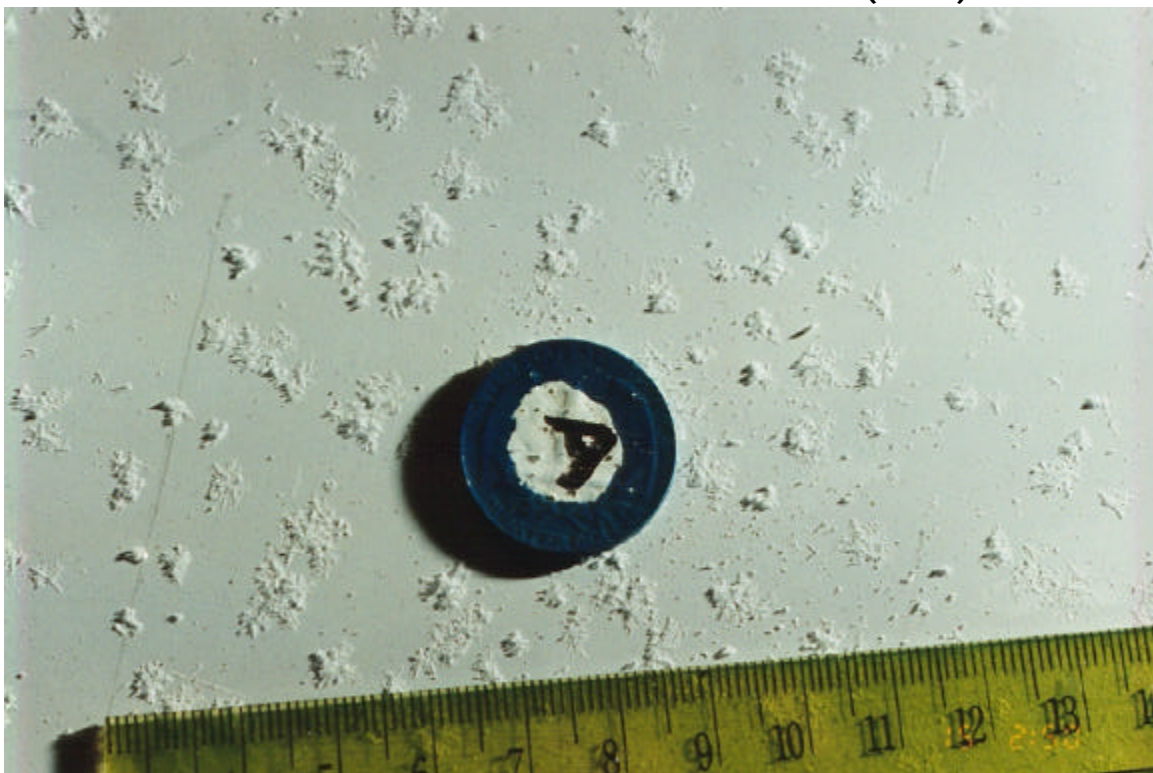

Photo 4.11
Overall Photo of the Frost Formation on the Aileron (ID# 3)

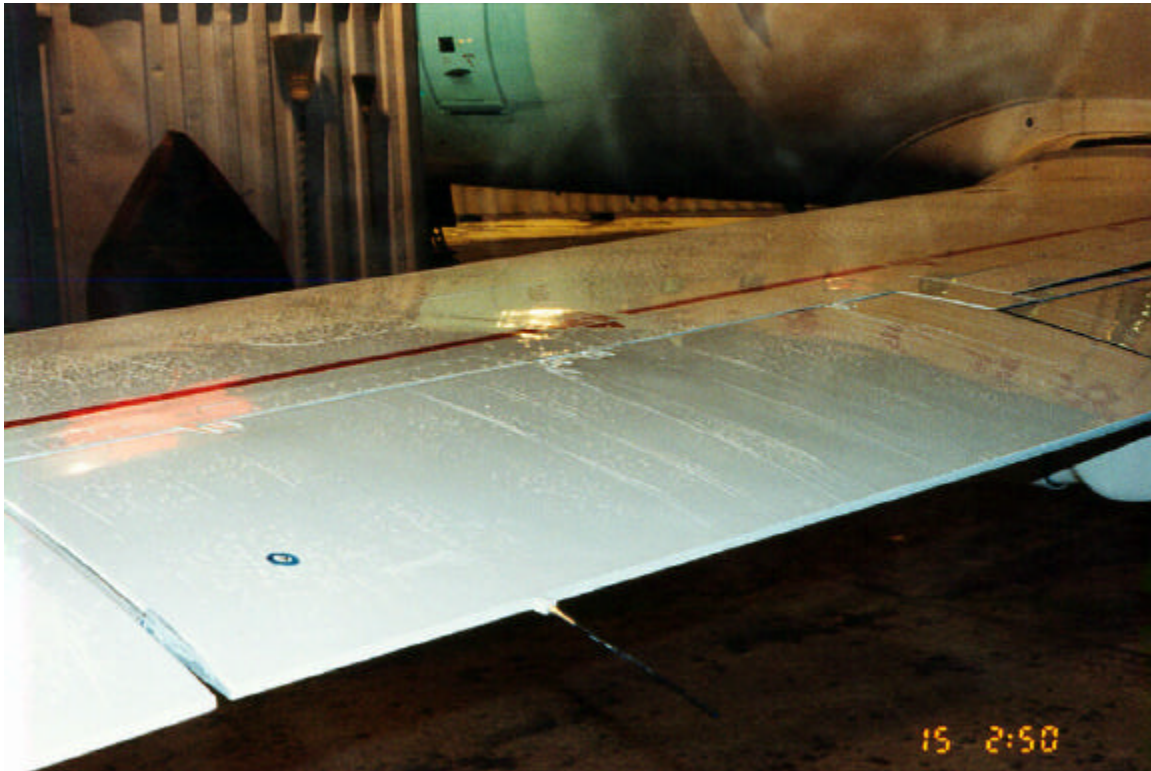

Photo 4.12
Plan Photo of the Frost Formation on the Outboard Spoilers (ID# 3)

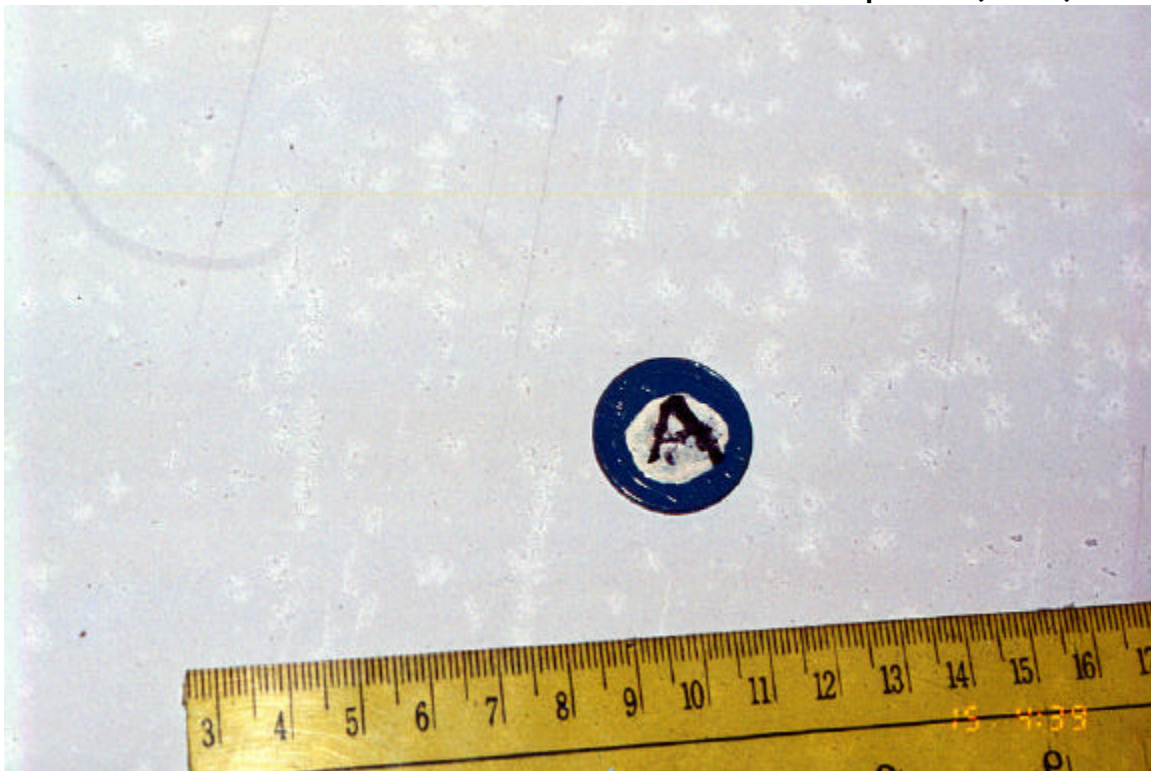

Photo 4.13
Overall Photo of the Frost Formation on the Outboard Spoilers (ID# 3)

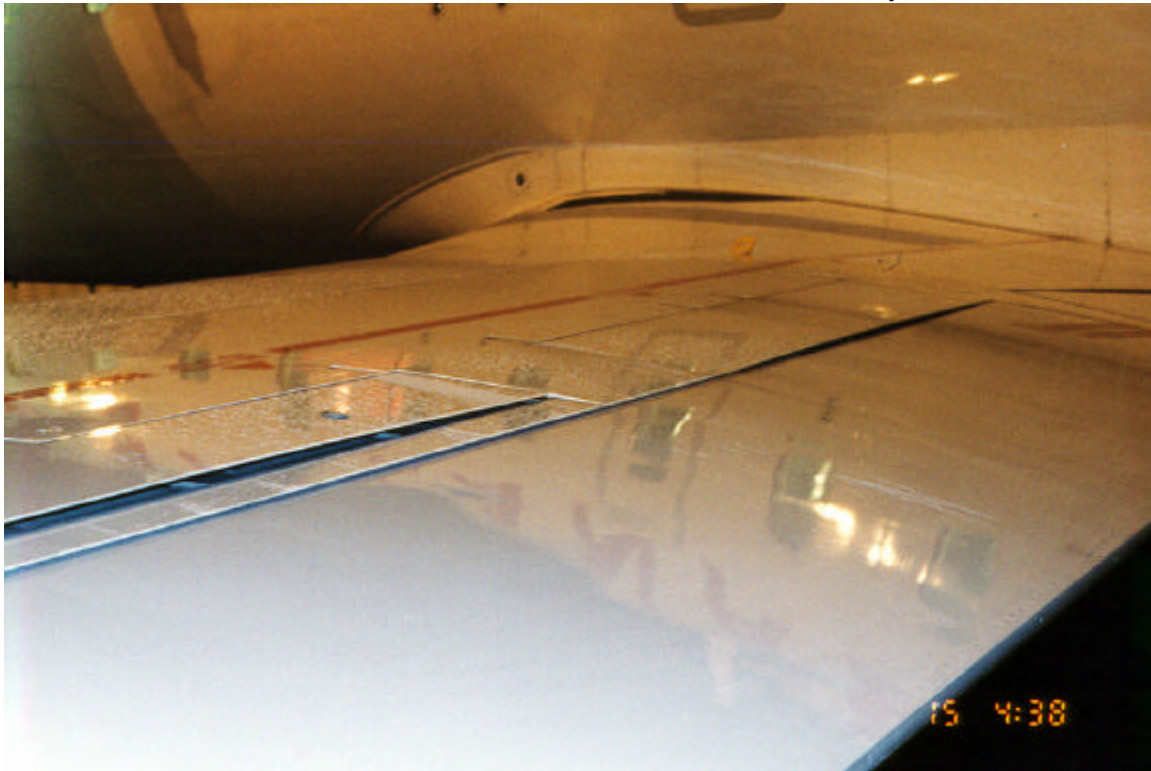

Photo 4.14
Plan Photo of the Frost Formation on the Outboard Flap (ID# 3)

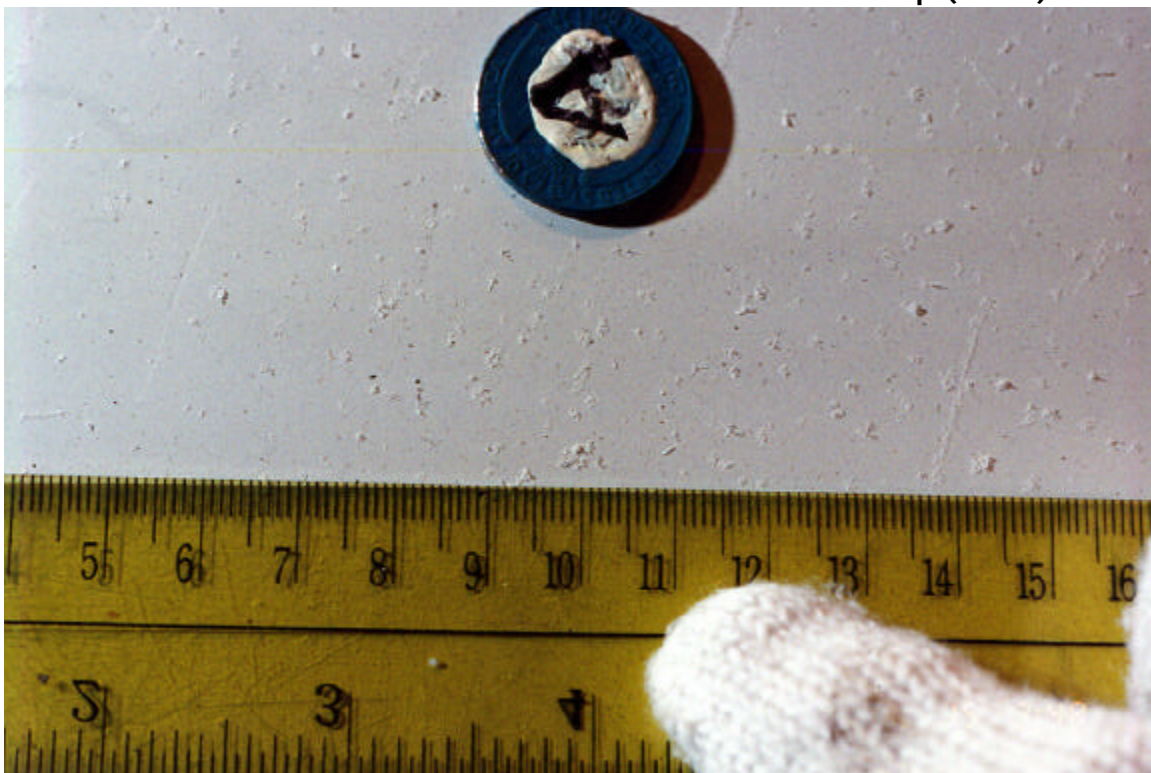

Photo 4.15
Overall Photo of the Frost Formation on the Outboard Flap (ID# 3)



Photo 4.16
Plan Photo of the Frost Formation on the Mid-Wing (ID# 3)

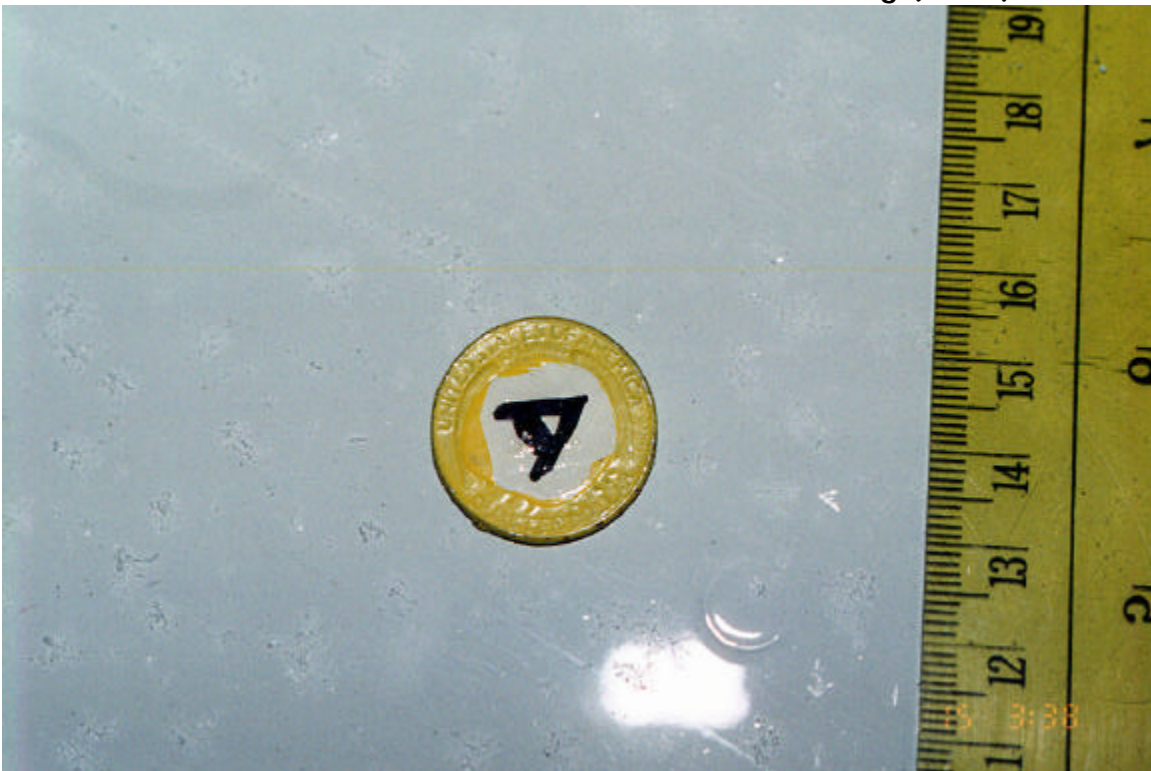

Photo 4.17
Overall Photo of the Frost Formation on the Mid-Wing (ID# 3)



Photo 4.18
Plan Photo of the Frost Formation on the Wing Tip (ID# 3)



Photo 4.19
Overall Photo of the Frost Formation on the Wing Tip (ID# 3)

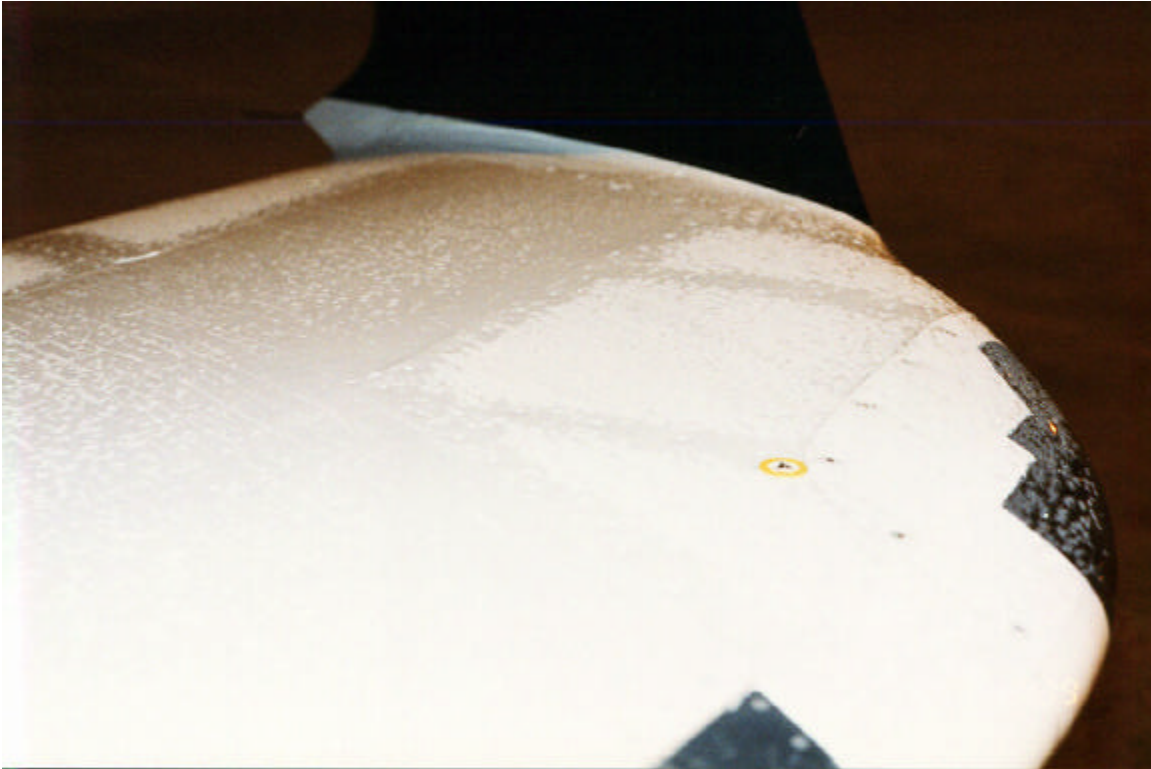

Photo 4.20
Plan Photo of the Frost Formation on the Trailing Edge (ID# 3)



Photo 4.21
Overall Photo of the Frost Formation on the Trailing Edge (ID# 3)

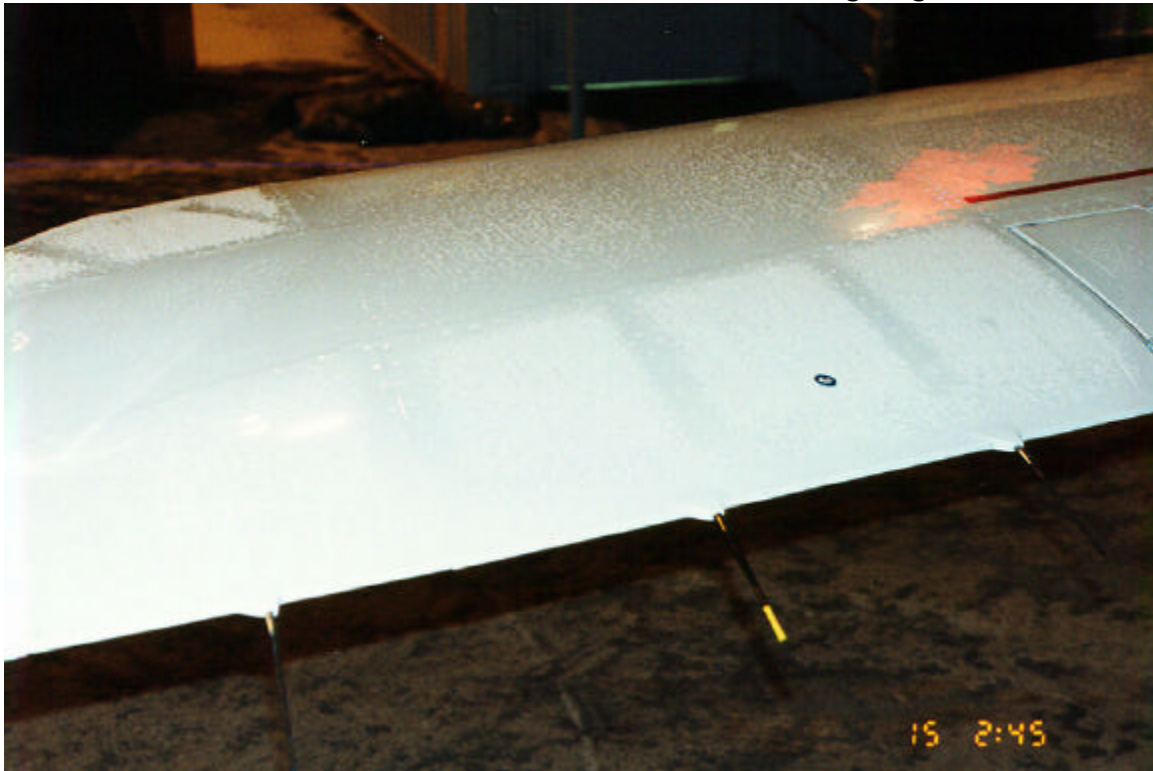

Photo 4.22
Photo of CL-65 Leading Edge (ID# 3)



5. DISCUSSION

5.1 Fluid Failure Tests on Operational Aircraft

Although no full-scale fluid failure tests were conducted during the 1998/99 test season, the methodology has been presented in this report because the same procedures will be followed in any future tests.

5.2 Frost Formation on Aircraft

In test case #3, in which frost roughness profiles were measured on the CL-65 aircraft at -11°C and 80 percent relative humidity, it was noted that the roughness height was 0.2 mm or less on all but the wing tip area outboard of the aileron where the height was 0.5 to 0.8 mm, and that the leading edge and inner 40 percent of the span remained frost free. The density of roughness varied from 1 to 2 high points per cm^2 in direct relation to the variation in height. In the two earlier tests, roughness height was not measured, but the general areas of contamination were the same. In all cases, distribution of frost was not uniform, with frost forming only on areas between the wing surface sub-structure members; that is, where there was no heat transfer from the warmer inner structure.

Kind and Lawrysyn (2) have concluded from calculations for sample light aircraft and supercritical airfoil sections that the presence of frost on wings can cause serious degradation of airfoil wing and take-off performance. However, this conclusion was drawn for the case of uniform frost with coverage beginning at or near the suction peak. Coverage beginning at, for example, a quarter-chord point was predicted to have little effect.

The empirical data collected shows that in practice under the observed conditions for the CL-65 aircraft, in both the most sensitive (leading edge) area and the high lift (wing inboard) area, frost did not form. Furthermore, in the areas where frost did form, it was by no means uniform in either height, density, or distribution. In the case of the leading edge, a set of parallel tests with respect to the impact of fuel temperature on frost formation (3) were conducted and involved temperature distribution measurements on the wing. These showed that the polished leading edge remained above the dew point even under conditions ideal for frost formation, presumably due to the very low radiant heat emissivity of brightly polished aluminium.

It can therefore be postulated that the frost problem for the CL-65 may be considerably less serious than earlier anticipated. This could be evaluated theoretically in detail using the observed test data and the more sophisticated

theoretical technique developed by Tezok and Boyce (4) as an advance on the simple approach to estimating the effects of roughness proposed by Brumby (5).

Conversely, the observations can be taken to show that a significant reduction in propensity to frost formation can be achieved by polishing bare metal surfaces.

The "worst" condition for frost formation will occur at an air temperature at or even possibly slightly above 0°C, on a clear night with zero wind and a relative humidity close to 100 percent. It would be of interest to record the frost intensity and distribution under these extreme conditions should a suitable occasion occur. In such an event, more sophisticated measurements would be made, possibly using an adaptation of the preservation technique successfully used and reported by Kind and Lawrysyn (2).

6. CONCLUSIONS

6.1 Fluid Failure Tests on Operational Aircraft

Despite the substantial groundwork undertaken to organize full-scale test sessions (including the preparation of test procedures, organization of test equipment, and training of test personnel), all attempts to obtain aircraft for full-scale fluid failure tests in winter 1998/99 failed. This lack of testing reinforces the need for the implementation of a deicing test site, centered around a wing test bed.

6.2 Frost Formation on Aircraft

In all tests conducted, the patterns of frost development on the wings of the Canadair Regional Jet were similar, regardless of the rate of frost deposition. Frost development initiates on the trailing edge outboard of the aileron, wing tip, and aileron. These same surfaces were also observed to contain the heaviest frost formations during tests. Frost also readily accumulates on the outboard flap section, outboard spoilers, and outer mid-wing sections. With the exception of small patches of frost contamination on the inboard flap section and inboard spoilers, no frost was observed to form on the inner wing sections. The leading edge of the Regional Jet aircraft, which consists of highly polished aluminum, was entirely frost-free in all trials.

Only one test was used in the determination of the surface area coverage, density, diameter, and height of frost formations. This test represented the onset of frost formation or a light frost formation. In the other two tests conducted, the surface area coverage of the frost was heavier, and the diameter and height of the frost formations may have been slightly higher than the single test documented. As noted above, the patterns of frost were similar in all tests.

The single test conducted to estimate the surface area coverage, diameter, density, and height of frost formations on the wings of a Canadair Regional Jet aircraft confirmed visual observations. Frost formation initiates and accumulates most heavily on the trailing edge outboard of the aileron, the wing tip, and the aileron itself. The surface area coverage of the frost formation on the trailing edge outboard of the aileron and on the wing tip were 94 percent and 80 percent respectively, vastly exceeding that of any other wing section. The aileron was next with 12 percent of its surface covered with frost. No other wing section contained more than 9 percent frost. The leading edge contained no frost whatsoever.

The same trend was apparent following the estimation of the mean frost diameter and mean frost height for each wing section. Mean frost diameters of 5 mm and mean frost heights of 0.5 to 0.75 mm were observed on the trailing edge outboard of the aileron and wing tip. The values were superior to those of the other wing sections, where diameters ranged from 1 to 4 mm and heights were 0.2 mm or less.

7. RECOMMENDATIONS

7.1 Fluid Failure Tests on Operational Aircraft

Thickness tests, conducted in 1995/96 on Canadair Regional Jet aircraft (see TDC report, TP 12900E) (6), indicated that fluid appeared to thin rapidly on the leading edge of this aircraft, and recommended further tests to investigate this phenomenon. These tests were not conducted during the 1997/98 and 1998/99 winters due to difficulties in securing RJ aircraft for test purposes.

Results from the single test session conducted on an ATR 42 high-wing turboprop aircraft (1996/97) proved to be inconclusive. Attempts were made during the past two seasons to test ATR 42 and de Havilland Dash 8 aircraft in periods of freezing precipitation; however, tests never materialized.

It is recommended that:

- Failure progression tests be conducted on Canadair Regional Jet aircraft, and on either the ATR 42 or the de Havilland Dash 8 to properly document the initiation and progression of fluid failure for these aircraft;
- Failure progression tests be conducted using other brands of Type IV fluid, to identify differences in fluid performance and behavior of these fluids on aircraft wings; and
- A study of the pilot's view of fluid failure from inside the cabin be conducted during full-scale aircraft trials. A pilot view test procedure was developed during the past test season.

7.2 Frost Formation on Aircraft

A method was developed for evaluating the diameter, height, and surface area coverage of frost formation on aircraft wings. This method of evaluation could be used to conduct frost tests with different aircraft types. In future trials to determine the height of frost formations, a ruler with smaller than one-millimetre divisions should be employed. A macroscope or microscope with measurement crosshairs should be considered.

This page intentionally left blank.

REFERENCES

1. Chaput, M., Ruggi, E., Hanna, M., *Development of a Plan to Implement a Full-Scale Test Site*, APS Aviation Inc., Montreal, October 1999, Transport Development Centre, TP 13487E, 24.
2. Kind, R. J., Lawrysyn, M. A., "Performance degradation due to Hoar Frost on lifting surfaces", June 1992, *Canadian Aeronautics and Space Journal*, Volume 38, No. 2.
3. Dawson, P., Hanna, M., Ruggi, E., *Evaluation of Warm Fuel as an Alternative Approach to Deicing*, APS Aviation Inc., Montreal, October 1999, Transportation Development Centre, TP 13482E.
4. Tezok, F., Boyce, F., *Effects of Roughness on Advanced Airfoils: Final Report for Phase II and Phase III*, Bombardier Aerospace, Montreal, March 1998, Transportation Development Centre, TP 13253E.
5. Brumby, R. E., "Wing surface roughness: cause and effect", *D. C. Flight Approach*, No. 32, 1979.
6. Dawson, P., D'Avirro, J., *Evaluation of Fluid Thickness to Locate Representative Surfaces*, APS Aviation Inc., Montreal, October 1996, Transport Canada report, TP 12900E.

This page intentionally left blank.

APPENDIX A

WORK STATEMENT

AIRCRAFT AND FLUID HOLDOVER TIME TESTS FOR WINTER 98/99

**APPENDIX A
TRANSPORTATION DEVELOPMENT CENTRE
WORK STATEMENT (EXTRACT OF)**

AIRCRAFT AND FLUID HOLDOVER TIME TESTS FOR WINTER 98/99

(December 1998)

4. PROJECT OBJECTIVES

4.8. Determine the patterns of frost formation and of fluid failure initiation and progression on the wings of high-wing turbo-prop and jet commuter aircraft.

4.16. Provide general support services.

4.17. Disseminate test findings.

5. DETAILED STATEMENT OF WORK

5.1. General

5.1.1. Planning and Control

Develop a detailed work plan, activity schedule, cash flow projection, project management control and documentation procedures (as specified in Section 9, "Project Control") within three weeks of effective commencement date, confirming task priorities, suggesting hardware and software suppliers, broadly identifying data needs and defining the roles of subcontractors, and submit to TDC for review and approval.

5.1.2. Safety and Security

Particular consideration will be given to safety in and around aircraft on the airport and deicing sites. In the event of conflict between access for data gathering to obtain required test results and safety considerations, safety shall always govern.

5.5. Aircraft Full-Scale Tests

5.5.1 Purpose of Tests

- Conduct full-scale aircraft tests:
- To generate data which can be used to assist pilots with visual identification of fluid failure;
- To generate data to be used to assess a pilot's field of view during adverse conditions of winter precipitation for selected aircraft; (See item 5.11)

- To compare the performance of de/anti-icing fluids on aircraft surfaces with the performance of de/anti-icing fluids on flat plates;
- To examine the pattern of failure using Type IV fluid brands not tested in the past; and
- To further investigate progression of failure on the two wings in crosswind conditions.

5.5.2. Planning and Coordination

Planning and preparation for tests including provision of facilities, personnel selection and training, and test scheduling shall be the same as provided to TDC in previous years

5.5.3. Testing

All tests and dry runs shall be performed using the methodology developed in the conduct of similar tests for Transport Canada in past years.

Test planning will be based on the following aircraft and facilities:

<u>Aircraft</u>	<u>Airline</u>	<u>Test Locn.</u>	<u>Deicing Pad</u>	<u>Deicing Crew</u>
Canadair RJ	Air Canada	Dorval	Central	Aéromag 2000
ATR42	Inter Canadian	Dorval	Central	Aéromag 2000

5.5.4. Test Measurements

Make the following measurements during the conduct of each test:

- Contaminated thickness histories at selected points on the wings. The selection of test points shall be made in cooperation with the Transportation Development Centre,
- Contamination histories at selected points on wings (selected in cooperation with the Transportation Development Centre),
- Location and time of first failure of fluids on the wings,
- Pattern and history of fluid failure progression,
- Time to failure of one third of the wing surface
- Concurrent measurement of time to failure of fluids on flat plates. The plates will be mounted on standard frames and on aircraft wings at agreed locations,
- Wing temperature distributions,
- Amount of fluid applied in each test run and fluid temperature,
- Meteorological conditions, and
- For crosswind tasks, effects of rate of accumulation on each wing.
- In the event that there is no precipitation during full-scale tests, the opportunity shall be taken to make measurements of fluid thickness distributions on the wings. These measurements shall be repeated for a number of fluid applications to assess the uniformity of fluid application.

5.5.5. Pilot Observations

Contact airlines and arrange for pilots to be present during the tests to observe fluid failure and failure progression, and to record pilot observations from the cockpit and the cabin for later correlation with aircraft external observations.

5.5.6. Remote Sensor Records

Record the progression of fluid failure on the wing using RVSI and/or Cox remote contamination detection sensors if these sensors are made available.

5.14. Provision of Support Services

Provide support services to assist TDC with testing, the reduction of data and presentation of findings in the activities identified below which relate to the content of this work statement, but are not specifically included.

5.14.1. Re-Hydration

Conduct a series of exploratory trials on flat plates at the Dorval site or NRC to observe the behaviour of re-hydrated Type IV fluids and to help determine how re-hydration affects the flow-off characteristics of a Type IV fluid exposed to frost conditions.

5.14.2. Frost Tests on a Regional Jet

Conduct a series of tests to determine the roughness of frost deposition on the wings of a Regional Jet aircraft. Conduct tests on three overnight occasions.

5.14.3. Ice-Phobic Materials Evaluation

Conduct a series of tests on flat plates to determine the effects of ice-phobic materials on the film thickness and on holdover time of de/anti-icing fluids.

APPENDIX B

**EXPERIMENTAL PROGRAM
FULL-SCALE FLUID FAILURE TESTING**

CM1514.001

**EXPERIMENTAL PROGRAM
FOR FULL-SCALE FLUID FAILURE TESTING**

Winter 1998/99



June 3, 2002
Version 1.0

**EXPERIMENTAL PROGRAM
FOR FULL-SCALE FLUID FAILURE TESTING**
Winter 1998/99

This document provides the detailed procedures and equipment required for the conduct of full-scale fluid failure testing for the 1998/99 winter season. The document is a revision to the documents used for testing during the previous winters.

1. PURPOSE OF TESTS

- Objective:
- To generate data which can be used to assist pilots with visual identification of fluid failure;
 - To assess a pilot's field of view during adverse conditions of winter precipitation for selected aircraft;
 - To assess whether Representative Surfaces can be used to provide a reliable first indication of anti-icing fluid failure;
 - To explore the potential application of point detection sensors to warn the Pilot-in-Command of an "unsafe to take-off condition";
 - To obtain failed fluid contamination distributions and profiles which can serve as inputs to a theoretical program designed to assess the effects of such contamination on possible aircraft take-off performance;
 - To compare the performance of de/anti-icing fluids on aircraft surfaces with the performance of de/anti-icing fluids on flat plates; and
 - For turboprop tests, to observe and record the impact that propeller wash over the top of the wing has on the film of deicing fluid, and on patterns of failure on those wings.
- Applications:
- To determine where pilots should concentrate visual inspection at the end of the holdover time, and to determine the extent of fluid failure during the five-minute period following first (leading edge) failure.

- To determine whether an array of point detection fluid integrity sensors, with an appropriate algorithm, can provide a reliable warning of an *unsafe to take-off* condition. A remote camera to detect ice will also be utilized.

2. AIRCRAFT, TEST LOCALE, AND TEST SET-UP

Aircraft: Canadair CL65, ATR 42, DeHavilland Dash 8

Locale: Dorval Airport, Montreal, Central Deicing Facility

- Test Set-up:
- Aircraft out-of-service, overnight tests based on predicted precipitation 24 hrs notice;
 - Aircraft cabin accessible for simulated pilot inspection of critical surfaces;
 - Aircraft parked at pre-determined orientation prior to start of test. Re-orientation required during each one-night test session;
 - De/Anti-icing to be performed by Aéromag 2000 Inc; and
 - Aircraft to be deiced and returned to *service* condition at completion of tests (prior to first airline use in the morning).

3. TEST PROGRAM

A matrix of tests is anticipated based on:

- Headwind, crosswind, and tailwind orientations;
- Application of Deicing, and Deicing/Anti-icing fluids; and
- Snow, freezing drizzle and light freezing rain precipitation.

Test Period (nominal):

- Early Dec. 1998 - 15 Apr. 1999;
- No tests on Sat/Sun & Sun/Mon overnights, and period Dec. 19 1998 - Jan. 4 1999, inclusive, unless by prior agreement; and
- A total of five one-night test sessions is anticipated, preceded by a *dry* run.

4. EQUIPMENT

Test equipment required for the tests is provided in Attachment III. Details and specifications for some of the equipment is provided in the experimental plan developed for Dorval's standard flat plate testing *Experimental Program for Dorval Natural Precipitation Testing 1998/99*.

5. PERSONNEL

Several personnel are required to conduct tests for each occasion. A description of the responsibilities and duties of each of the personnel is provided in Attachment IV. Depending upon the weather forecast at the site, the number of personnel may be reduced or increased. Figure 1 shows a schematic of the positioning of the test personnel. Ground support personnel from the airlines will be available to apply fluids, position the aircraft and facilitate the inspection of the critical aircraft surfaces.

6. SUMMARY OF PROCEDURE AND MEASUREMENTS

The test procedure is included in Attachment V. The following observations are anticipated: pilot assessment of wing condition from inside the aircraft; and trained observer assessment of wing condition from outside the aircraft.

Fluid thickness histories: advantage will be taken of occasions when precipitation stops during the night to take thickness measurements on uncontaminated fluids.

Comparison of fluid performance on the aircraft with fluid performance on standard test plates.

Video-record coverage of the tests will be made.

7. DATA FORMS

The data forms are listed below:

- | | | |
|-------------|--------------------------------------|----------|
| • Figure 3 | General Data Form (every test) | T5 |
| • Figure 3a | General Data Form (once per session) | T6 |
| • Figure 4 | De/Anti-icing Form for Aircraft Wing | T2/T4/T8 |
| • Figure 5 | Fluid Thickness on Aircraft | - |
| • Figure 6 | Fluid Thickness on Flat Plates | - |
| • Table 1 | End Condition Data Form | T3 |
| • Table 2 | Meteo/Plate Pan Data Form | T1 |

8. ROLES OF PARTICIPATING AGENCIES

APS: To coordinate and conduct tests on behalf of TDC.

TDC: Transport Canada or its contractor/representative will organize the tests. Transport Canada will assume the cost of trained observers, conduct of tests and provision of instrumentation, ancillary lighting, and power supplies. Transport Canada will assume the cost of Air Canada ground crew. Transport Canada will make appropriate arrangements Aéroports De Montréal as necessary, and with Aéromag 2000 Inc. for use of the deicing facility. Findings and reports will be made available to the aviation community.

Airlines: Provide and tow aircraft. Provide access by pilot to the cabin.

Others: Union Carbide and Octagon will provide fluid samples. Aéromag 2000 will provide a deicing vehicle, personnel and access/use of the deicing centre. RVSI and/or Spar/Cox will be requested to provide a remote sensor.

9. PROPOSED NOTICE PROCEDURE

	<u>Notice given</u>
i) Potential for testing	24 to 48 hrs before
ii) Day of testing - Monitoring throughout day	By 4:00 pm
iii) Day of testing - Confirm or cancel (if possible)	By 8:00 pm
iv) Proceed to Deicing Pad	10:00 pm
v) Preparation/Briefing	10 to 11:00 pm

10. EQUIPMENT AND SERVICES REQUESTED FROM AIRLINES

Airlines are requested to make available aircraft for Transport Canada to implement the above test program.

Aircraft to be initially positioned, re-positioned following individual tests, and towed away at end of each one-night test session.

Aéromag 2000 Inc. is requested to provide a de/anti-icing truck with crew for fluid application in accordance with the above program.

Direct cost of crew to be borne by contractor. Credits for fluids will be given by the fluid manufacturer.

ATTACHMENT I
PROCEDURE FOR CONDUCTING TESTS ON PROPELLER AIRCRAFT
Winter 1998/99

1. OBJECTIVE

The pertinent objective of these tests is to observe and record the impact that propeller wash over the top of the wing has on the film of deicing fluid, and on patterns of failure on those wings. The ATR 42 and DHC DASH 8 aircraft are planned for these tests. Further reference on procedures for these tests can be found in the related document prepared for full-scale testing.

2. SAFETY CONSIDERATIONS

The objective by definition can only be satisfied by operating the engines and propellers. Turning propeller blades are a well recognized danger in ramp operations, and operators of propeller aircraft in general have strict procedures to ensure personnel are kept well away from danger zones during propeller operation.

Tests involving personnel not trained and experienced in ramp operations must take particular care to ensure safety of personnel.

Additional safety awareness issues are contained in the full-scale fluid failure testing procedure.

The test program examines patterns of failure on the wing of a propeller aircraft. The procedure for these tests is based on the test procedure for full-scale tests and the following sequence of events for turboprops:

- i) Apply the test fluids on wing with engine shut down. Simultaneously, initiate a fluid test on flat plates on a stand situated outside the danger zone and clear of influence of the propeller airstream. Move all personnel back away from the aircraft.
- ii) Start the engine, advance the throttle to operating speed with propeller blades in normal pitch used for taxiing. The operational expertise and procedures of the operator will be the rule in this phase of the test. Allow the engines to continue running until the plate on the test stand has failed, then shut down the engines. This may be varied to trigger engine shut down upon plate failure at the 2.5 cm (1") line, or other rule as may be determined during actual testing.

- iii) Move access ladders to the wing edge to allow examination of the surface for fluid failure, and continue monitoring throughout remaining progress of fluid failure. Collect fluid samples as indicated in Attachment VI.
- iv) Simultaneous tests on the opposite wing could be considered, as well as repositioning the aircraft to examine impact of tail into the wind and crosswind.

3. SENSOR CONSIDERATIONS

Use of an area scanning sensor mounted in a location allowing viewing of the wing during engine running would be a possible alternative. The current plan outlooks use of an RVSI or Spar sensor. As this coincides with planned tests on the turboprop aircraft, consideration will be given to the possibility of employing this sensor to monitor the wing condition during engine operation.

4. TEST PLAN

Attachment IIA provides a list of tests to be conducted under conditions with precipitation. The conditions required for the tests are listed.

5. EQUIPMENT/PERSONNEL

Test equipment required for the tests is provided in Attachment III. Attachment IV provides guidance for personnel assigned to the full-scale precipitation tests with turboprops.

6. DATA FORMS

The data forms for the turboprop precipitation tests are included in the full-scale fluid failure test procedure.

ATTACHMENT II

TEST PLAN FOR TURBOFAN FULL-SCALE FLUID FAILURE TESTS

OCCASION	RUN #	FLUID ⁽¹⁾ TYPE	A/C ORIENTATION
1	1	I / IV	Tail
1	2	I	Tail
1	3	I	Tail
1	4	I / IV	Cross
1	5	I / IV	Cross
1	6	I	Cross
1	7	I	Cross
1	8	I / IV	Head
1	9	I	Head
1	10	I	Head

⁽¹⁾ Selection of fluid is dependent upon precipitation rate.

This page intentionally left blank.

ATTACHMENT IIA
**TEST PLAN FOR
 TURBOPROP FULL-SCALE TESTS**

WITH PRECIPITATION

RUN #	FLUID TYPE	AIRCRAFT ORIENTATION	WING
1	—	Tail	Starboard
2	—	Tail	Port
3	—	Cross*	Starboard
4	—	Cross*	Port
5	—	Cross**	Starboard
6	—	Cross**	Port
7	—	Head	Starboard
8	—	Head	Port

* Wind direction such that starboard wing is on upwind side and port wing is on downwind side.

** Wind direction such that port wing is on upwind side and starboard wing is on downwind side.

This page intentionally left blank.

ATTACHMENT III
 FULL-SCALE FLUID FAILURE TESTS
 TEST EQUIPMENT CHECKLIST

Logistics for Every Test
15 Block Passes
Rent two mast lights
Rent Truck
Call Personnel
Advise Airlines (Personnel, A/C Orientation, Equip)
Monitor Forecast
Call potential participants
Book escort if required
Test Equipment
15 Procedures
All data forms required (wing, plates, general)
1 Blue stand with 4 x 1/8" thick plates W,X,Y,Z
2 Mast lights and 1 spare generator
3 x 500 Watts tripod lights
Red pylons
6 Rolling stairs(2 Tall, 2 Med, 2 Small)
7 Step ladders (2 Tall, 2 Med, 2 Small, 1 Short for truck)
Stand fluids: Type I and Type 4 in red containers
Extension chords 4 x extension cords stored in bin.
1 tool kit including socket set, hammer, tie-wraps, duct tape, safety goggles, spare Batteries (AA, D)
1 parabolic heater
2 Suction cup plate pans
2 Standard plate pans
2 Wide plastic shovels, 2 small steel shovels
2 big and 2 small squeegees
2 small plate scrapers
Pens and pencils
Paper Towels, rags
1 First aid kit
4 extended octagon thickness gauges + 4 x ordinary Octagon thickness gauges
1 Rates station with 2 weight scales, 1 table for station
Rain suits
8 Stop watches
2 Two black markers
3 Tape measures (1 long, 2 standard)
1 whistle
3 Flashlights
5 Clipboards
2 Ink solvent bottles
1 anometer
2 Temp gauges (1 extended tip and 1 normal tip)
2 Laser pointers
5 Head set radios and chargers
1 Brixometer
2 Tape recorders
Extra mini cassettes for tape recorders
24 video cameras power batteries, 1 belt power pack, and 1 power regulator
3 Video cam CR2025 spare batteries
9x8 mm film
3 Video cameras batteries chargers
2 Photo cameras 35 mm, 1 Nikkon, 1 Snappy
Plastic glue for video cameras
35 mm film
1 video cam AC cable
3 Photo camera lithium 223 power batteries
1 video cam RCA cable
1 Megaphone
Garbage bags
1 filling pocket for data forms
2 Tripods for video/photo cameras
All individual kit boxes: V1, V2, P1, T3, T2/T4, T5, T6, T7, T8, Sampling, Marking
1 Adherence brush prototype
OTHER TEST EQUIPMENT (1)
Type I fluid for the wing
Type IV fluid for the wing
Sprayer Vehicle (Aeromag)
A/C
Storage Facilities
Fluid Collection Facilities
Airline Personnel

(1) To be provided by others

This page intentionally left blank.

ATTACHMENT IV
Full-Scale Fluid Failure
RESPONSIBILITIES/DUTIES OF TEST PERSONNEL

Refer to Figure 1 for position of equipment and personnel relative to the aircraft. Also refer to the test procedure (Attachment V) for more detailed tester requirements.

Video 1 (V1/V2)

- One video operator per wing;
- Located on ground (Refer to the flat plate test procedure);
- Ensure proper plate identification - zoom in and out;
- Knowledge of test procedures and end conditions;
- Video application of all fluids;
- Assist in deployment and return of lighting;
- To video wing before and after fluid application, to concentrate on fluid contamination and failure; and
- Ensure proper identification of wing.

Photographer (P1)

- Photograph aircraft test site;
- Photograph wing during and after fluid application, to concentrate on fluid contamination and failure;
- Overall photography of wing condition is extremely important;
- Photograph fluid roughness on wing (Refer to Attachment XI) and photograph cabin views;
- Picture to be steady and well lit;
- Photography of both wings required; and
- Knowledge of test procedures and end conditions.

Meteo/Equipment Tester (T1)

- Coordinate all equipment (inventory and operation);
- Record meteo for both stands;
- Rotate and measure plate pan weights;
- Complete and sign data form (Table 2);
- Ensure power cables and lighting is in place;
- Prepare plate pans;
- Ensure all clocks are synchronized (including video camera); and
- Record rates on both aircraft wings during crosswind tests.

Wing Observers (T2/T4)

- Located on ground (rolling stairs) or in cherry picker;
- Communicate with V1/V2 and P1, and T5;
- Make observations of failures on starboard or port wing; and
- Knowledgeable in procedures and calling end conditions.

End Condition Tester (T3)

- Apply fluids to Stand;
- Located by Test Stand;
- Make observations and call end conditions on test stand; and
- Knowledge of procedures for test stands.

Wing/Plate Coordinator (T5)

- Ensure failure calls on plates and wings are consistent;
- Communicate initial failure to all involved;
- Assist wing and plate observers as required;
- Assist overall coordinator as required;
- Complete and sign general data form (Figure 3) for each test;
- Manage and direct equipment deployment and return;
- Assist T1 in coordination of equipment;
- Communicate with cabin observer the spraying of wing A and wing B;
- Review data forms upon completion of test for completeness and correctness (sign);
- Ensure proper documentation of tapes, diskettes, cassettes; and
- Call personnel to conduct tests.

Overall Coordinator (T6)

- Team Coordinator;
- Knowledge of test procedures and calling end conditions;
- Responsible for area and people;
- To aid any personnel;
- Coordinate actions of APS team and as required airline personnel;
- Responsible for weather condition observations and forecast, advise tester team;
- Ensure that there are no objects on the ground which may cause foreign object damage at end of session;
- Ensure test site is safe, functional and operational at all times;
- Supervise site personnel during the conduct of tests;
- Ensure aircraft positioned appropriately;
- Monitor weather forecasts during test period;
- Ensure fluids are available and verify fluids being used for test are correct;
- Ensure electronic data are being collected for all tests ;
- Verify test procedure is correct (eg. stand into wind);
- Ensure all materials are available (pens, paper, batteries, etc.);
- Ensure all equipment is on;
- Ensure aircraft is not damaged; and
- Complete general data form (Figure 3a) at beginning of night.

RVSI and Spar/Cox (V1/S1)

- Knowledgeable in procedures and calling end condition; and
- Take images of fluid failure on starboard and port wing.

Cabin Observer (T7)

- Located in aircraft cabin;
- Make observations of failures on starboard or port wing;
- Knowledgeable in procedures and calling end conditions;
- Video and photograph contamination and failure on wing; and
- Ensure proper identification of wing.

Sampler (T8)

- One fluid sampler for both wings;
- Collect fluid samples at first failure location, and at several other points of failure;
- Communicate with T2/T4 for locations of failure;
- Knowledge of test procedures and end conditions;
- Measure wing temperatures at beginning of night; and
- Collect fluid samples from deicing truck at the start of testing.

This page intentionally left blank.

ATTACHMENT V TEST PROCEDURE

1. TRAINING AND SAFETY

Training for this experiment will consist of a dry-run in which team members are assembled and duties are assigned to each member. This will allow the team to conduct an experiment in which team members will coordinate their activities to prepare for a systematic and comprehensive execution of a given experimental run and try to determine the logistics of an actual experiment. The dry run will familiarize all test members with the equipment and provide the participating airline with an understanding of the procedure. This procedure will inevitably be streamlined during field testing. Most team members should be familiar with salient aspects of flat plate testing. They should possess the ability to identify fluid failures, and call end conditions.

Attachment VII refers to Safety Awareness Issues for these tests. Ensure that these are observed and understood.

2. PRE-TEST SET-UP

Figure 1 should be consulted in reference to the responsibilities.

1. Arrange favourable aircraft orientation (**leading edge, crosswind or trailing edge into the wind**) and place pylons below wings to delineate sections.
2. Set-up power cords and generator.
3. Position stairs and lights.
4. Ensure temperature probes and weigh scale are functional.
5. Position flat plate test stand into the wind as per the flat plate test procedure. Note that this orientation may be different than that of the aircraft.
6. Position pre-filled test fluid containers, squeegees, and scrapers accordingly. (Type I fluids are stored inside at 20°C; Type IV fluids are applied at ambient temperature).
7. Check cameras, sensors and recording devices for proper function.
8. Ensure proper illumination of test areas.
9. Position RVSI and/or Spar/Cox sensor on truck.
10. Establish communication between team members and coordinator.
11. Camera and test personnel ensure ability to identify laser light signature.
12. Synchronize all timepieces including video cameras.
13. Ensure airline personnel are aware and knowledgeable of test procedures.
14. Prepare data forms in advance of all tests.

3. INITIALIZATION OF FLUID TEST

1. Ensure all aircraft de/anti-icing systems are off.
2. Measure and record fuel load in wing to be tested.
3. Measure wing skin temperature at predetermined locations before fluid application (see Figure 3a).
4. Record all necessary data from fluid delivery vehicle (cherry picker). (Temperature, nozzle-type, fluid type, dilution of fluid, etc.).
5. Record all general measurements and general information in the data forms.
6. Ensure all fluids are prepared to the appropriate concentrations.
7. Collect a sample of fluid from deicing truck.

4. EXECUTION OF FLUID TEST

a) Turbofan Tests

1. Type I Fluid Application (Figure 2a)
 - 1.1 Apply Type I fluid with deicing vehicle to wing; and
 - 1.2 Simultaneously apply Type I to plates V and Y from containers.
2. Type IV Fluid Application (Figure 2b)
 - 2.1 Apply Type I and then Type IV to wing with deicing vehicle; and
 - 2.2 Apply Type IV to plate W and Z when application of Type IV to the wing begin.
3. Plate/wing coordinator sounds whistle once to confirm the beginning of test (after fluid application).
4. Put two plate pans on test stand and note time and initial weights (see Attachment XIII for rate procedure). Continue measuring every five minutes until end of test. Re-measure when second wing is started.
5. Take RVSI and Spar/Cox sensor images every 15 minutes (see Attachment XII for sensor procedure).
6. Continue testing until the end conditions are called for both flat plates.
7. Collect fluid samples as per the test procedure in Attachment VI.

b) Turboprop Tests

The turboprop test program examines patterns of failure on the wing of a propeller aircraft. The procedure for these tests is based on the test procedure for full-scale turbofan tests and the following sequence of events for turboprops:

1. Apply the test fluids on wing with engine shut down. Simultaneously, initiate a fluid test on flat plates on a stand situated outside the danger zone and clear of influence of the propeller airstream. Move all personnel back away from the aircraft.
2. Start the engine, advance the throttle to operating speed with propeller blades in normal pitch used for taxiing. The operational expertise and procedures of the operator will be the rule in this phase of the test. Allow the engines to continue running until the plate on the test stand has failed, then shut down the engines. This may be varied to trigger engine shut down upon plate failure at the 2.5 cm (1") line, or other rule as may be determined during actual testing.
3. Move access ladders to the wing edge to allow examination of the surface for fluid failure, and continue monitoring throughout remaining progress of fluid failure. Collect fluid samples as indicated in Attachment VI.
4. Simultaneous tests on the opposite wing could be considered, as well as repositioning the aircraft to examine impact of tail into the wind and crosswind.

5. HOLDOVER TIME (END CONDITION) TESTING

Holdover time testing will consist of: A) Video/photo recording of all procedures and fluid failures; and B) Visual monitoring and manual recording of failure data. Attachment XII contains a typical procedure for recording contamination on the wing with a remote sensor.

A) *Video/Photo Recording (V1/V2, P1)*

Camera recordings are to be systematic so that subsequent viewing of documented tests allow for the visual identification of failing sections of the wing surface with respect to the aircraft itself.

1. Record the complete fluid application on plates and wing from a distance.
2. Record the conditions of the flat plate set-up and the wing at time = 0.

3.
 - i) For Type I fluids, record conditions of wing and flat plates every two minutes.
 - ii) For Type IV fluids, record conditions of wing and test plates every five minutes.
 4. Once the first failure on the wing or on the one inch line is called, monitor (record) continuously until the end of the test.
 5. Record condition of the wing and representative surface continuously from the aircraft cabin.
- B) *Visual Recording*
1. For the plates, refer to the flat plate test procedure for determination of the end condition.
 2. For the wing, three ways to record visual observations have been devised.
 - i) Manual recording of failure contours on preprinted data form (Figure 4). This is to be performed by person making the observations, and/or
 - ii) Observer may talk to a voice recorder, and/or
 - iii) Observer may talk directly to the video camera microphone.

In any case, the methods would utilize the De/Anti-icing Form for Aircraft Wing (Figure 4), and these are complementary to the video recording.

It was found in previous tests that using generic wing plans, available from the literature test forms, did not always provide accurate detail for the actual wings tested. Accurate wing details must be portrayed on the data form wing plan to support accuracy in drawing failure locations and patterns. Modification of generic wing plans, based on inspection of actual test wings sometime prior to the test session, is necessary;

- C) Due to the rapid propagation of failures, especially in the case to Type I tests, the time and precise location of first failure was sometimes missed. In certain tests, rapid failure had progressed to the 25% level at the time of documenting the first failure contour. Procedures and training must emphasize the requirement to identify the precise location of first failure, and additional observers are to be assigned from the test team complement to assist in failure identification when rapid progress of failure is expected. A further discipline can be added by requiring observer comments on wing conditions at defined intervals while awaiting occurrence of first failure;
- D) The pattern of failures should be drawn on the data form every **5 minutes for Type I and every 15 minutes for Type IV after first failure on the wing.**
- E) When the first flat plate failure is reported at the 5th crosshair (a of plate), the visual data recorder must acquire contours every 2 to 5 minutes, thereafter. Time increment is dependent upon weather. Process is

continued until all flat plates have failed according to the end condition defined in the flat plate test procedure.

- F) If wing fails before first flat plate fails, continue data collection for wing via contour drawing and/or voice communication until all flat plates fail.
- G) Wing/plate coordinator must confirm initial end condition calls on flat plate tests. Once the first flat plate fails at the six inch line (a of plate), the coordinator is notified and makes inspection of the wing contour drawing to confirm the accuracy of the wing data and instructs video camera operator to make a record of the area. The area should be located using a laser pointer. If the wing start to fail first, the coordinator must confirm this and simultaneously note areas of failure on the flat plates using the laser pointer.
- H) Measure wing skin temperatures at the start of the evening. If the wing is cold-soaked, then continue monitoring the temperatures.

6. END CONDITION

Refer to the flat plate test procedure for this definition.

7. END OF TEST

Plate/wing coordinator sounds whistle to confirm the full failure of wing (end of run). This occurs when all plates have reached the end condition (under heavy snow conditions, continue testing until nine crosshairs have failed) and when a substantial part of the aircraft wings leading/trailing edge has reached the end condition. Ensure all data collection are completed including plate pan measurements.

This page intentionally left blank.

ATTACHMENT VI TEST PROCEDURE FOR FLUID SAMPLING

1. Prior to the start of testing, the refractive index of the Type I and Type IV fluids in each truck should be taken using a hand-held refractometer and recorded on the sampler's wing data form (Figure 4) for the first test run. As well, a Type IV fluid sample should be collected from each truck and placed in a small sample container. On each container, information such as the date, truck number, airport, operator and sample number should be recorded. The containers should then be stored in a safe location and returned to the test site following each test session.
2. At the beginning of the night, the temperatures at several locations on the wing (shown in Figure 3a) should be taken by the sampler using a temperature probe mounted on an extension pole. Temperatures should be recorded in the box in Figure 3a.
3. After the location of first wing failure has been identified by the wing observer, a fluid sample should be collected at this position. A small sample of fluid (average mixture) from this location should be placed in a hand-held Brixometer and the refractive index and sample time immediately recorded on a wing data form (Figure 4). Also, the skin temperature at this location should be taken. When recording sample times, Brix values and skin temperatures on the data sheet, simply circle the location on the wing plan and write in the information below the circle. Make sure that the written information is clear!
4. Subsequent wing samples should be collected using the same procedure at various points of failure on the wing (as indicated by the wing observer).
5. A new data sheet should be used by the sampler for each run.

This page intentionally left blank.

ATTACHMENT VII
SAFETY AWARENESS ISSUES

- 1) Review MSDS sheets for fluids at site.
- 2) Protective clothing is available.
- 3) Care should be taken when climbing rolling stairs due to slipperiness.
- 4) When moving rolling stairs, ensure they do not touch aircraft.
- 5) To take fluid samples or measure film thickness on the aircraft, ensure minimum pressure is applied to the wing.
- 6) Entry into the aircraft cabin is not authorized, except for cabin observer (T7), video (V1), or overall coordinator (T6). For these people, booths are to be removed at entrance.
- 7) When aircraft is being sprayed with fluid, testers and observers should be positioned away in the hold area (see Figure 1).
- 8) First aid kit, water and fire extinguisher is available in trailer. Second first aid kit is available in mobile truck.
- 9) No smoking permitted on the ramp area and in trailer.
- 10) Care to be taken when moving generators and fuel for the generators.
- 11) Electrical cabling is needed to power lights - these will be positioned around the wing - do not trip over them. Do not roll stairs or other equipment over cables.
- 12) Do not walk by yourself in any area away from the pad or trailer - if required to do so, ask the coordinator T6 who will advise the security escort service.
- 13) Gasoline containers are needed to power the generators - ensure you know where these are.
- 14) Ensure lights and rolling stairs are stabilized to not damage the wing.
- 15) Ensure all objects and equipment are removed from deicing pad at end of night.
- 16) Ensure all markings removed from wing.
- 17) Personnel with escort required passes must always be accompanied by persons with permanent passes.
- 18) Rolling stairs should always be positioned such that the stairs are into the wind. Small ladders should be laid down under windy conditions.
- 19) For turboprop tests, the test objective by definition can only be satisfied by operating the engines and propellers. Turning propeller blades are a well recognized danger in ramp operations, and operators of propeller aircraft in general have strict procedures to ensure personnel are kept well away from danger zones during propeller operation.
- 20) Tests involving personnel not trained and experienced in ramp operations must take particular care to ensure safety of personnel.

This page intentionally left blank.

ATTACHMENT VIII TEST PROCEDURE FOR MEASURING FLUID THICKNESS

Fluid thickness tests on aircraft and flat plates will be conducted during periods of no precipitation. This may be during test events when snow or rain fall has ceased, or during dry runs.

The following instructions are to be followed when measuring fluid thickness:

- Use the MIL scale on the octagonal thickness gauge;
- Record the gauge of the tooth that is wetted;
- When measuring fluid thickness, follow offset routine to avoid inaccuracies related to depressions in fluid surface caused by previous gauge placement;
- Ensure the thickness gauge is perpendicular to the surface of the wing;
- Record time in seconds during the initial measurements when the rate of fluid thinning is fastest. Time to the nearest minute is acceptable for subsequent recording;
- Wipe gauge following each measure attempt; and
- Proceed as quickly as possible without sacrificing accuracy.

FLAT PLATES

Thickness tests on flat plates consist of one-step procedure where only Type IV (Union Carbide Ultra+ or Octagon Maxflight) is applied:

- Apply some Type IV fluid on plate and squeegee to clean it;
- Apply Type IV fluid and record start time;
- Immediately proceed to measure and record thickness at 2.5 cm (1") and 15 cm (6") lines; and
- Repeat thickness measurements for 30 minutes, with higher frequency during the initial measurements, until fluid thickness is stabilized.

AIRCRAFT WING

- i) Locations where fluid thickness will be measured are shown in Figure 5. Indicate measurement points using a black marker. (Ensure markings are removed at end of test, using solvent).
- ii) Fluid thickness will be measured four times; two initial fluid thickness measures taken immediately following fluid application, and subsequently at 10 minutes and at 30 minutes following fluid application.

- iii) Measure each location three times to increase reliability of results; record the thickness measure resulting from these consecutive trials. Ensure that thickness gauge placement for consecutive measures is slightly offset from previous placement to avoid influence of indents remaining in fluid film. Wipe gauge following each measure attempt.

- iv) Record data on the Fluid Thickness Data Form, Figure 5, in the format shown; measurement location, time, gauge reading.

ATTACHMENT IX
MOBILE EQUIPMENT FOR EACH TESTER

<i>Video V1/V2</i>	÷ batteries ÷ video camera ÷ charger ÷ 8 mm film ÷ pens/pencils
<i>Photographer P1</i>	÷ photo camera ÷ batteries (for 35 mm camera) ÷ 35 mm films ÷ pens/pencils ÷ VHF radio
<i>Meteo/Equipment T1</i>	÷ pens/pencils ÷ stop watch ÷ clipboard ÷ data form (Table 2) ÷ plate pans, plate pans with suction cups ÷ mobile equipment for truck (see Attach. X)
<i>Wing/Plate Coordinator T5</i>	÷ test procedure ÷ stop watch ÷ laser pointer ÷ flash light ÷ data form (Figure 3) ÷ pens/pencils ÷ clipboard ÷ compass ÷ VHF radio
<i>Wing Observer T2/T4</i>	÷ data form (Figure 4) ÷ laser pointer ÷ pens/pencils ÷ stop watch ÷ clipboard
<i>End Condition T3</i>	÷ data form (Table 1) ÷ pens/pencils ÷ stop watch ÷ compass ÷ clipboard

- Cabin Observer T7*
- ÷ video camera
 - ÷ batteries
 - ÷ data form (Figure 4)
 - ÷ pens/pencils
 - ÷ stop watch
 - ÷ tape recorder
 - ÷ VHF radio
- Overall Coordinator T6*
- ÷ test procedures
 - ÷ flash light
 - ÷ pens/pencils
 - ÷ stop watch
 - ÷ clipboard
 - ÷ tape recorder (x1)
 - ÷ data form (Figure 3a) (x1)
 - ÷ small tape measure
 - ÷ VHF radio
- Mobile Marking Kit*
- ÷ flashlight
 - ÷ tape measure - long
 - ÷ marker
 - ÷ ink remover solvent
 - ÷ degreaser
 - ÷ pencils
 - ÷ tape measure - short
 - ÷ aluminium tape
- Sampler T8*
- ÷ data form (Figure 4)
 - ÷ clipboard
 - ÷ Brixometer
 - ÷ pens/pencils
 - ÷ stop watch
 - ÷ temperature probe
 - ÷ skin temperature equipment

ATTACHMENT X
MOBILE EQUIPMENT REQUIRED FOR TRUCK (VAN)

Weigh scale x 2 (with battery backup)

Table and chairs

Light and electrical extension cable

Heater dish

Wind protection booth

Step ladder (non-slip)

Plate pans

Skin temperature equipment

- Mobile box with extra:
- pens and pencils
 - data forms
 - clipboard
 - batteries
 - paper towels
 - flash light
 - thickness gauge
 - test procedure
 - first aid kit
 - fire extinguisher

This page intentionally left blank.

ATTACHMENT XI PROCEDURE FOR ROUGHNESS ON AIRCRAFT WING

Equipment:

- 35 mm camera with date back and macro lens;
- Film - 35 mm 800 ASA;
- Walkie-Talkie;
- Spray paint - red, yellow, orange, purple, aqua marine, burgundy, blue;
- Markers - black, white; and
- Quarters - 16 (American).

Details:

- Each wing has been broken up into seven sections (see wing diagrams). The seven sections on each wing have a designated colour;
- The coins have been painted according to the sections colours;
- The coins are also indicated by an A (port wing) or B (starboard wing); and
- There should also be several unpainted quarters to indicate point of initial failure on each wing.

Procedure:

- When the point of initial contamination is determined by the wing observer, an unpainted coin (bearing an A or B) is placed at this location and photographed plan, profile and overall (see explanation).
- When failures occur elsewhere on the wing (confirmed by wing observer), the colour designated coins should be placed in the appropriate sections and photographed plan, profile and overall (see explanation); and
- A final set of photographs for each section of wing is to be taken at end of test (wing failure).

Three photos per location:

1. Overall location of coin relative to the rest of wing.
2. Macro profile of coin to determine surrounding crystals height, shape and size.
3. Macro plan of coin to determine the roughness and texture of surrounding crystals relative to the coin.

ATTACHMENT XI
FIGURE 1

INDEX OF COLOURS FOR PHOTOS OF ROUGHNESS ON AIRCRAFT WING

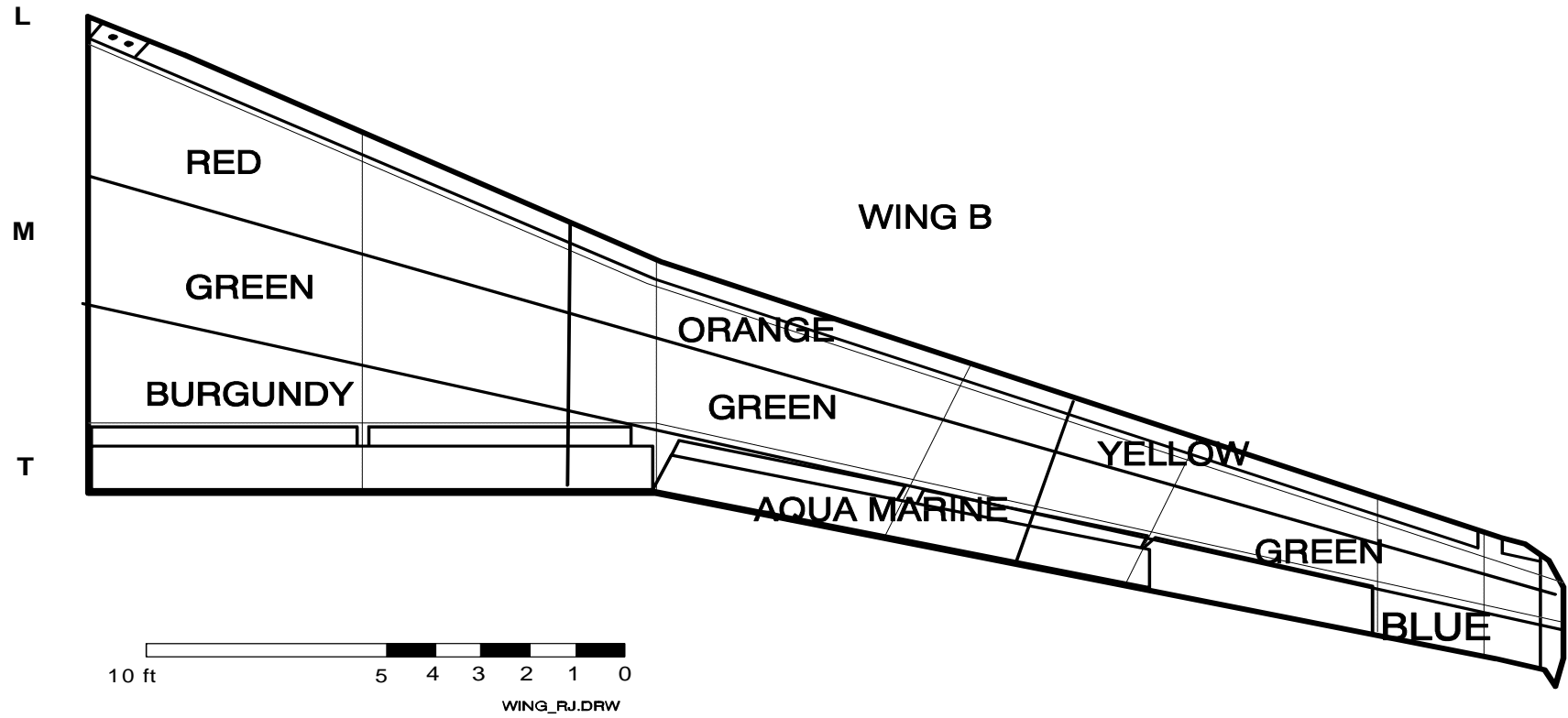

ATTACHMENT XII SENSOR PROCEDURES

Test Procedure and Equipment

- At initial application of Type I fluid the RVSI operator will take an image of the aircraft's tail identification numbers in order to determine fluid holdover time.
- Use a grid structure such as in the diagram to take images of the failure. Take four images across base of wing overlapping each frame. As you progress towards the wingtip less images are needed across the width of the wing. ** Try to get some identifying object in each frame so as to be able to easily identify location at a later date. **
- Number of images taken are as follows. Every fifteen minutes one entire series of images covering the wing should be performed.
- At end of the test procedure the tail numbers will be image again in order to show that all previous images are associated with that particular aircraft.
- For turboprop tests, use of an area scanning sensor mounted in a location allowing viewing of the wing during engine running would be a possible alternative. The current plan outlooks use of an RVSI or Spar/Cox sensor. As this coincides with planned tests on the turboprop aircraft, consideration will be given to the possibility of employing this sensor to monitor the wing condition during engine operation.

Figure -2 ID-1H SENSOR MODULE A HAND-HELD VIDEO SCANNING UNIT.

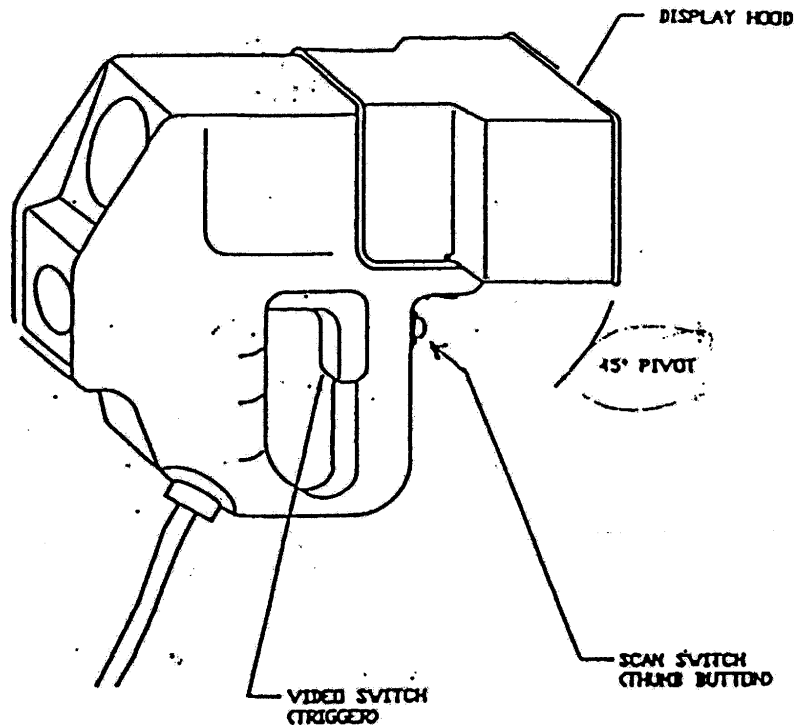

Sensor Module Components:

- Video Switch (trigger)
- Scan Switch
- Adjustable Display Screen and Hood

Pulling the video trigger will enable the viewer to see a real time video and record the area of the aircraft being checked. The display screen hood is adjustable for operating at various heights. *PIVOTS FOR COMFORTABLE VIEWING*

When taking a digitally enhanced image, Press and release the scan button. First a black and white still image will appear; then an enhanced image appears. Enhanced images are:

- Green indicates no contamination
- White indicates contamination
- Black means that the scanned object is out of range. This will give a range error message on the monitor.

Reinitiate the next video scan by depressing the scan button.

BREAKDOWN OF BOEING 737-200 FOR RVSI ID-1H IMAGING

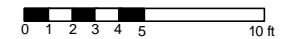
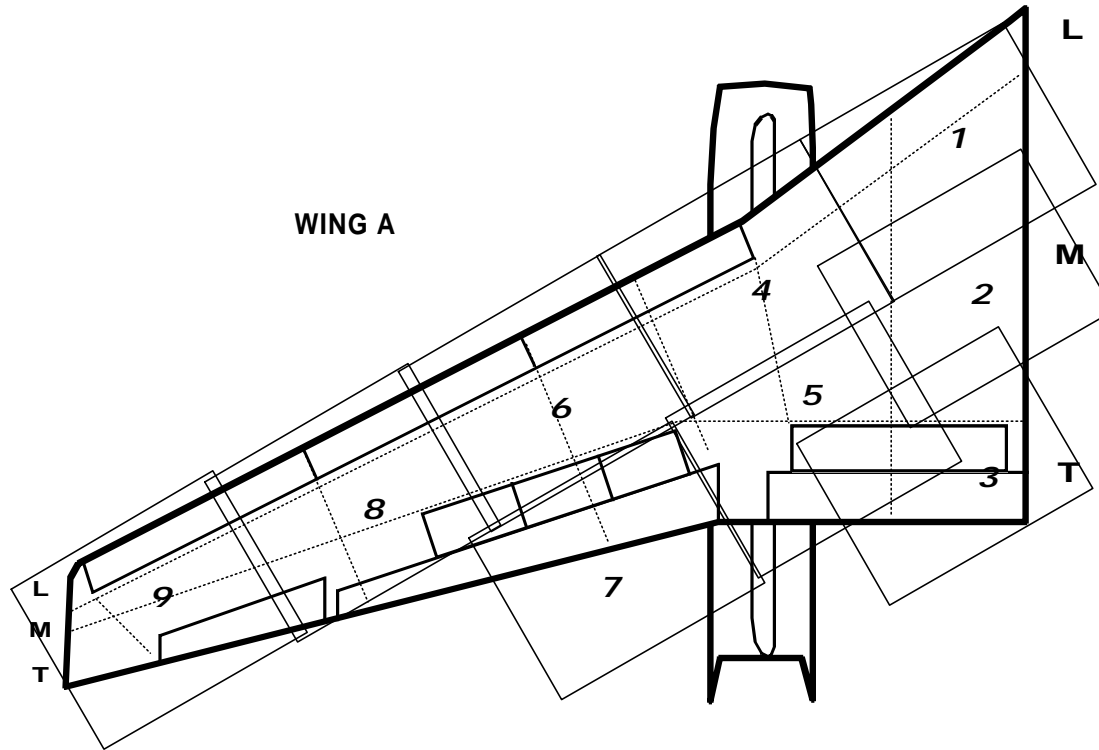

This page intentionally left blank.

ATTACHMENT XIII
EXPERIMENTAL PROGRAM
PROCEDURE FOR THE COLLECTION OF PRECIPITATION
Winter 1998/99

GENERAL

- i) A timepiece should be installed near the rate station to insure that accurate collection times are recorded. All watches used in testing should be synchronized;
- ii) Rates should be collected every five minutes.
- iii) In the event of error (dropped pan, lost fluid...), the error and time should be recorded on the data form. When fluid has been lost from the plate pans, pans should be reweighed prior to being placed on the test stand; and
- iv) When recording start and end times, a few seconds should be added or subtracted for the time delays created by entering and exiting the truck.

PROCEDURE

- i) Ensure that both plate pans are marked (*upper* and *lower*);
- ii) The bottom and sides of the pan must be wetted with Type IV anti-icing fluid to prevent blowing snow from escaping the pan;
- iii) Tare the scale, then weigh the wetted pan to the nearest gram;
- iv) Record the start time (hr/min/sec) from the timepiece located near the rate station before leaving the truck to place the pans on the test stand, taking into consideration the time delay necessary to proceed outside from the rate station;
- v) Ensure that the pans are placed in the proper location (upper and lower locations);
- vi) Prior to removing the plate pans from the test stand for re-weighing, carefully wipe away any accumulated precipitation from the lips of the plate pans (ensure that the precipitation does not fall into the plate pan). Carefully remove the plate pans from the stand and proceed **immediately** to the truck to re-weigh the pans. Do not rest the pans on top of one another while transporting. Once inside the truck, rest the pans on a clean dry table surface;

- viii) Upon entering the truck, record the end time (hr/min/sec) from the timepiece near the rate station;
- ix) Carefully wipe the bottom, sides and lips of the pans prior to weighing;
- x) Weigh the plate pan. Plate pans should be re-weighed until consistent measurements are obtained;
- xi) Record the new weight (do not tare scale again), and bring the pans back outside;
- xii) Start time from the timepiece near the rate station; and
- xiii) Continue this procedure until the final plate on the test stand has failed.

CROSSWIND PROCEDURE

- xiv) During the course of full-scale tests conducted in crosswind conditions, rates of precipitation will be collected on both aircraft wings as well as on the test stand. Plate pans with suction cups will be used for this purpose, and the rate collection procedure should be respected. One plate pan should be positioned on the mid-section of each wing (not on the leading or trailing edges). Plate pans should be reweighed following complete wing failure for Type I tests and every 15 minutes for Type IV tests.

ATTACHMENT XIV
EXPERIMENTAL PROGRAM
FULL-SCALE FLUID FAILURE PILOT PROCEDURE

Pilots will be present at full-scale test sessions to record observations from inside the cabin and/or cockpit on fluid failure and failure progression, which will later be correlated with external observations. Refer to the flat plate test procedure for definitions of fluid failure.

- Pilots will be located in the cabin of the aircraft in order to observe and note the progression of fluid failure on the wing. A pilot coordinator will also be present in the cabin;
- Observations of fluid failure patterns and drawings of failure contours will be completed by the pilots and pilot coordinator from the cockpit and cabin for each test run and will be recorded on the appropriate wing data form (Figure 4). A separate data form should be used for recording failure contours at each location (one for the cabin/overwing, one for the cockpit);
- Observations of fluid failure from the cockpit should be recorded with the cockpit window open if possible;
- Cabin observations can be made from any location within the cabin. It is important to record the time of the observation;
- In order to simulate wing observations in operational conditions, the pilot coordinator must insure that the side of the fuselage is deiced and that the windows remain uncleaned following deicing;
- Observations and failure contours should be recorded by the pilot coordinator at first wing failure and at pre-determined time intervals thereafter for Type I and Type IV tests with the exterior lights on. The pilots inside the cabin should not be observing the wing during this period;
- In order to simulate a pre-takeoff inspection at night under conditions of precipitation, all external lighting will be shut down at the request of the pilot coordinator and the on-board lighting turned on. The pilots will record progression of failure observations under these conditions from the same onboard locations (cockpit and cabin). The time of exterior light shutdown should not exceed one minute for Type I and two minutes for Type IV fluid. Two new data forms (one for cabin observations, one for cockpit observations) should be completed by each pilot for each test run;

- A video camera installed on a tripod should be positioned in the window providing the best overwing view of failures and should be running for the duration of testing (ensure proper focus); and
- Opinions and comments on wing visibility from the aisle, as well as comparisons with operational conditions should be recorded at different times during testing by the pilots, and should be recorded on a separate data form.

Full-Scale Fluid Failure Pilot Procedure Data Form for Information on Pilot

Date:

Pilot ID Number:

Experience:

How many years have you been a commercial pilot operating in areas subject to ground icing?

_____ years

During the last 4 years¹ how many times per year:

- (a) was your aircraft deiced _____
- (b) did you make a pre-take-off inspection _____
- (c) did you re-deiced your aircraft because you felt the fluid may have failed _____

Training for Recognizing Fluid Failure

During your training for ground icing, have you:

- (a) received verbal instructions for recognizing fluid failure..... Yes No
- (b) been shown black and white pictures of fluid failure Yes No
- (c) been shown colour photos of fluid before and soon after fluid failure Yes No
- (d) been shown videos of fluid failing..... Yes No
- (e) been shown (live) fluid in process of failure Yes No

How many months ago did you:

- (a) receive your last recurrent training for ground icing? _____ months
- (b) review properties to look for when determining if the fluid has failed? _____ months

Confidence

How confident are you that you can recognize fluid failure accurately at night near the end of the runway with no external lighting during:

	Confidence: Low				High
(a) snowfall	1	2	3	4	5
(b) freezing rain.....	1	2	3	4	5

¹ If now retired, answer for the last 4 years you were a commercial pilot

Full-Scale Fluid Failure Pilot Procedure Data Form for Comments by Pilots on Each Run

Date:
Pilot ID Number:

Run Number:

After each inspection of the wing with lights out, finalize areas where you observed fluid failure, then answer the following two questions (give answer in table below).

Q1. How did the reduction in visibility due to fluid on the windows compare with what you have experienced in actual pre-take-off inspections. Visibility here is:

1. better than what I have previously experienced
2. better than average, but within range of previous experience
3. very typical of previous experience
4. worse than average, but within range of previous experience
5. worse than what I have previously experienced

Q2. If you did not identify any failed fluid (FF) on the wing, answer the following question:

Picture yourself in an actual departure situation where your flight was already late due to deicing, you need to connect with other flights, and you make an inspection of the wing under the same conditions as this test (i.e., the inspection and observation you just made). Taking into account:

- the visibility of wing and the difficulty is determining fluid failure,
 - the fluid type and holdover time remaining (or expired), and
 - the wind and precipitation type & rate;
- would you return to redeice?: Yes / No

Inspection	Q1: Visibility reduction due to fluid on windows					Q2. Return to Deice?
No. 1	1.	2	3	4	5	Observed FF / Yes / No
No. 2	1.	2	3	4	5	Observed FF / Yes / No
No. 3	1.	2	3	4	5	Observed FF / Yes / No

At end of Test Run

Q3. How did the lighting on the wing compare with what you have experienced in actual pre-take-off inspections near the runway apron at night. Visibility of the fluid due to the lighting here is:

1. better than what I have previously experienced
2. better than average, but within range of previous experience
3. very typical of previous experience
4. worse than average, but within range of previous experience
5. worse than what I have previously experienced

Comments:

FIGURE 1
POSITION OF EQUIPMENT AND PERSONNEL

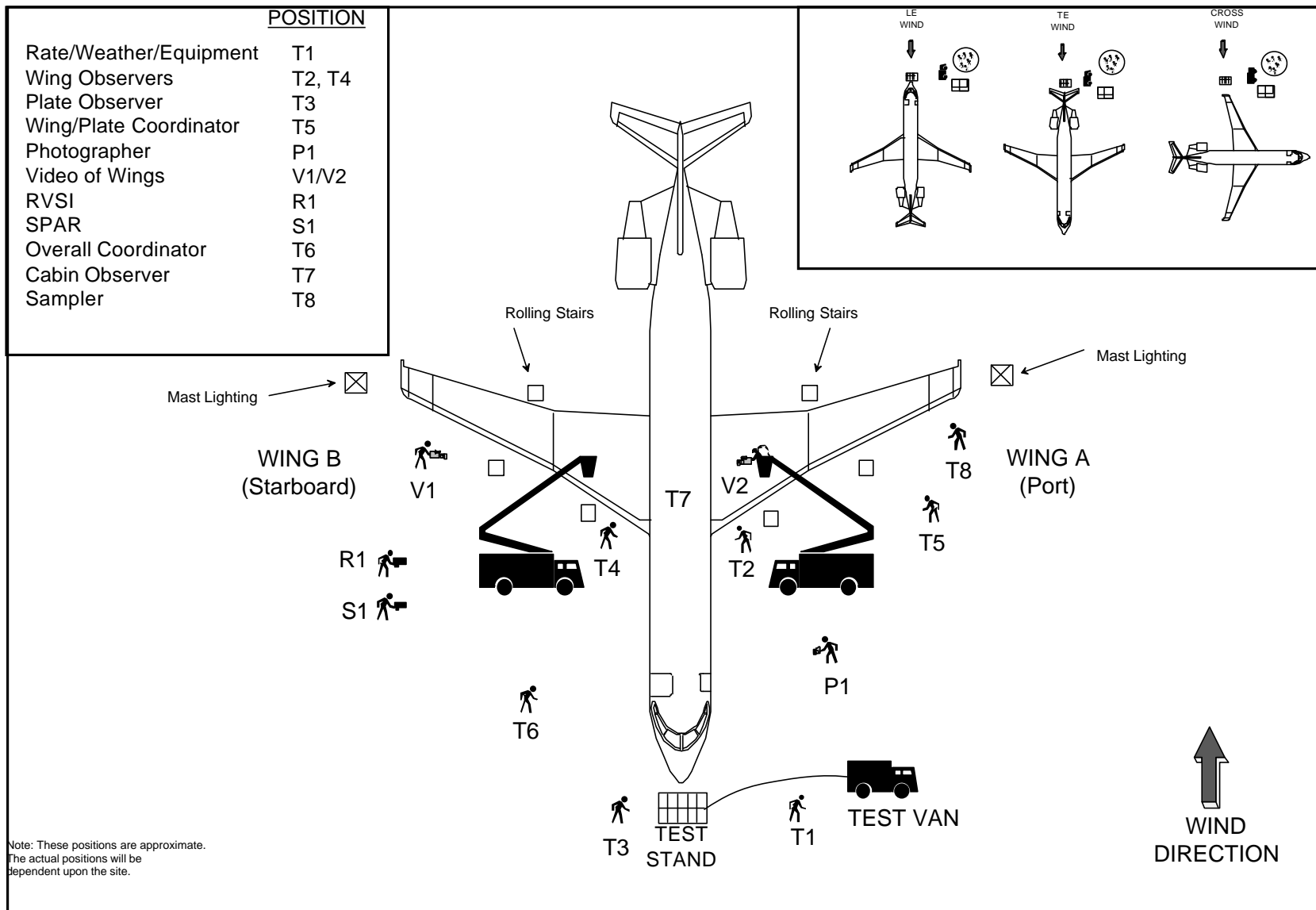

FIGURE 2a
TYPE I FLUID APPLICATION

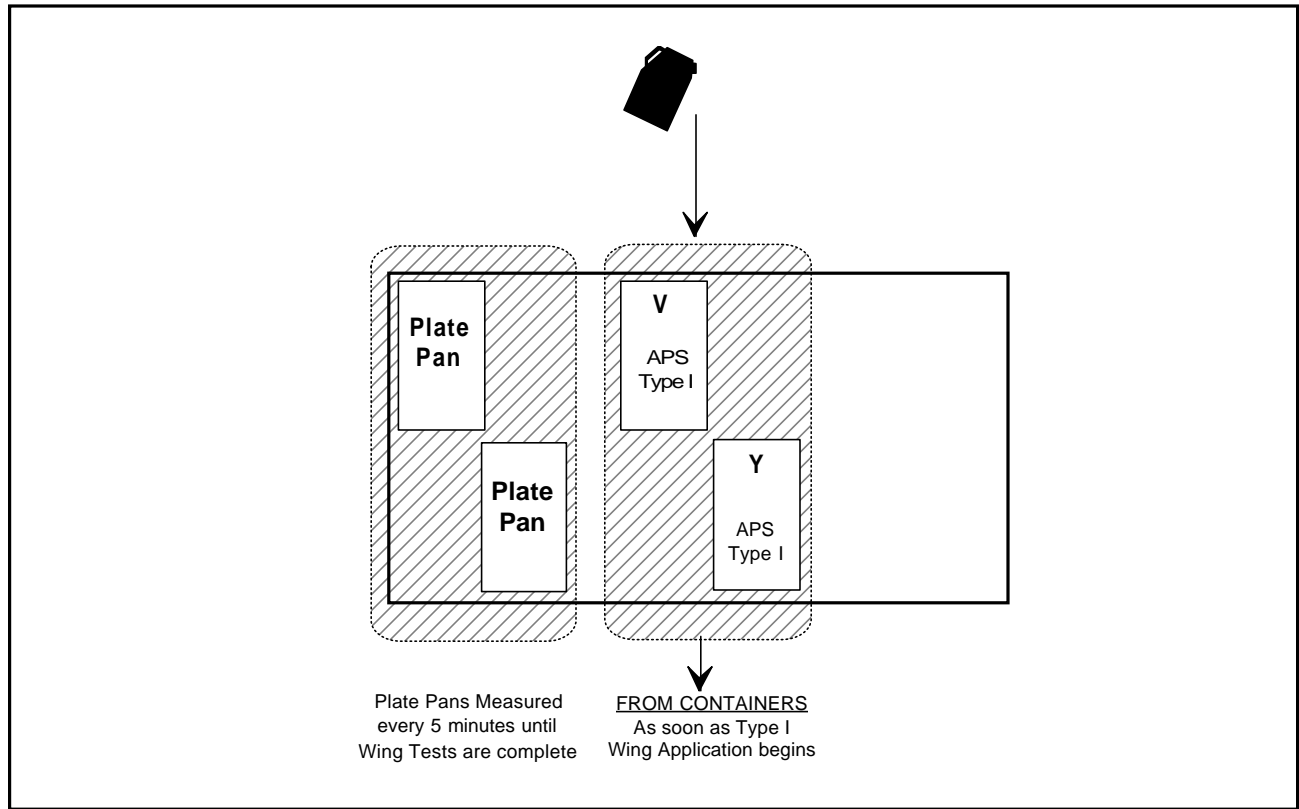

FIGURE 2b
TYPE IV FLUID APPLICATION

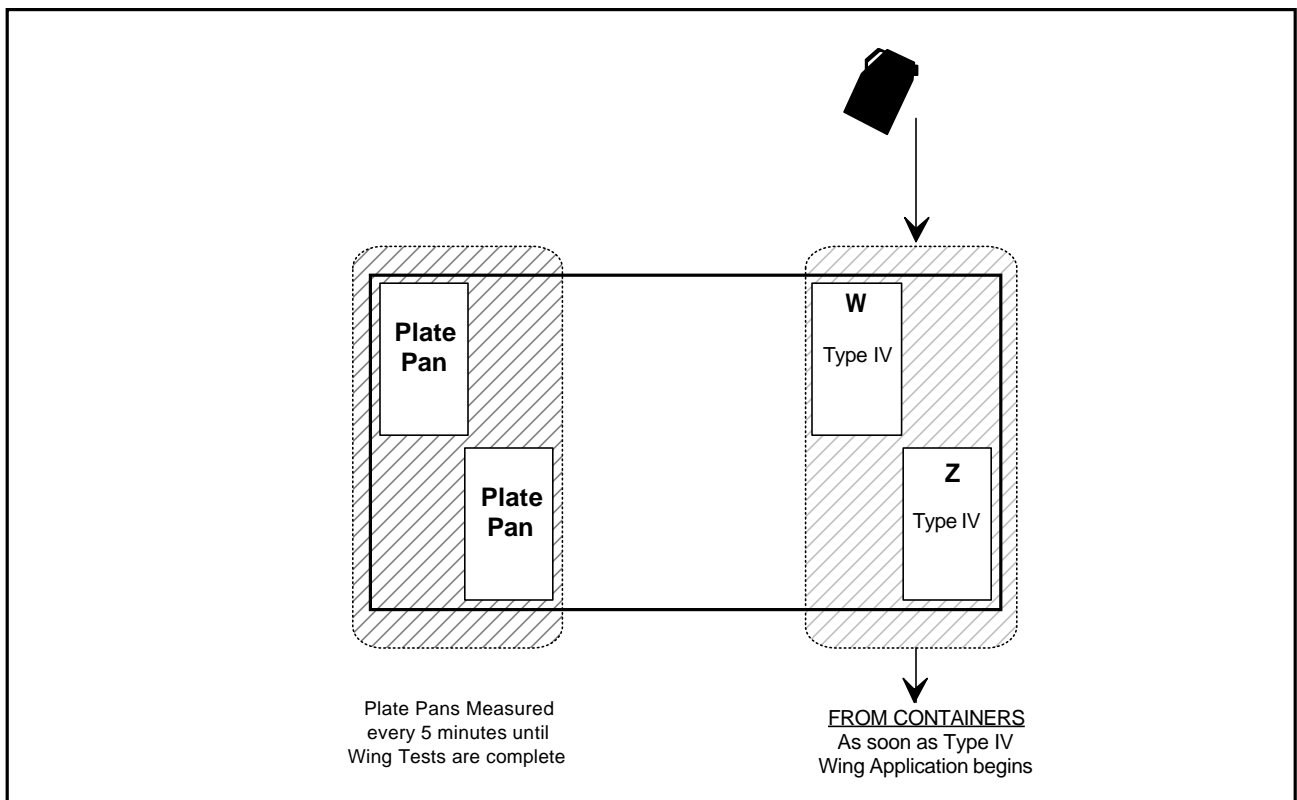

FIGURE 3
GENERAL FORM (EVERY TEST)
(TO BE FILLED IN BY PLATE/WING COORDINATOR)

DATE: _____

AIRCRAFT TYPE: ATR-42 F-100 B-737 RJ DHC-8

RUN #: _____

WING: PORT (A) STARBOARD (B)

DIRECTION OF AIRCRAFT: _____ DEGREES

DRAW DIRECTION OF WIND WRT WING:



1st FLUID APPLICATION

Actual Start Time: _____ am / pm

Actual End Time: _____ am / pm

Amount of Fluid Sprayed: _____ L / gal

Type of Fluid: _____

2nd FLUID APPLICATION

Actual Start Time: _____ am / pm

Actual End Time: _____ am / pm

Amount of Fluid Sprayed: _____ L / gal

Type of Fluid: _____

End of Test Time: _____ (hr:min:ss) am/pm

COMMENTS:

MEASUREMENTS BY: _____

HAND WRITTEN BY: _____

FIGURE 3a
GENERAL FORM (ONCE PER SESSION)
(TO BE FILLED IN BY OVERALL COORDINATOR)

AIRPORT: YUL YYZ YOW

AIRCRAFT TYPE: ATR-42 F-100 B-737 RJ DHC-8

EXACT PAD LOCATION OF TEST: _____

AIRLINE: _____

DATE: _____

FIN #: _____

APPROX. AIR TEMPERATURE: _____ °C

FUEL LOAD: _____ LB / KG

<i>TYPE I FLUID APPLICATION</i>	<i>TYPE IV FLUID APPLICATION</i>
TYPE I FLUID TEMP: _____ °C Type I Truck #: _____ Type I Fluid Nozzle Type: _____ Sample collected: Y / N	TYPE IV FLUID TEMP: _____ °C Type IV Truck #: _____ Type IV Fluid Nozzle Type: _____ Sample collected: Y / N

TEMPERATURE MEASUREMENTS

ENTER FLUID TYPE:						
TIME (min)	TEMPERATURE AT LOCATION (°C)					
	M6/7	M5/6	L4/5	M4/5	M3/4	M2/3
Before ¹ ()						

(1) Actual Time Before Fluid Application

COMMENTS: _____

MEASUREMENTS BY: _____

HAND WRITTEN BY: _____

FIGURE 4
DE/ANTI-ICING FORM FOR AIRCRAFT WING

REMEMBER TO SYNCHRONIZE TIME

VERSION 4.0

Winter 97/98

DATE: _____	RUN NUMBER: _____
-------------	-------------------

FAILURES CALLED BY: _____ COMMENTS: _____

HANDWRITTEN BY: _____

ASSISTED BY: _____

DRAW FAILURE CONTOURS (hr:min) ACCORDING TO THE PROCEDURE

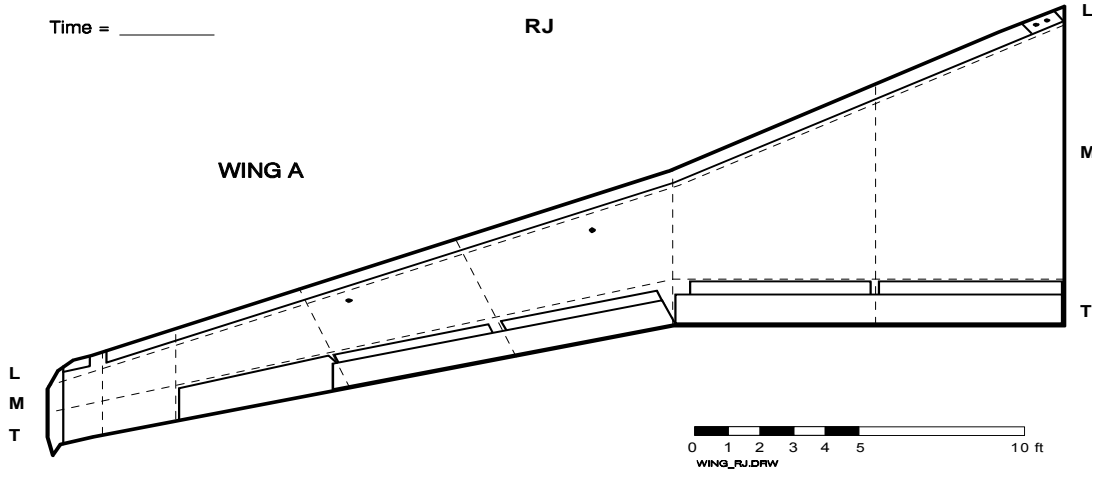
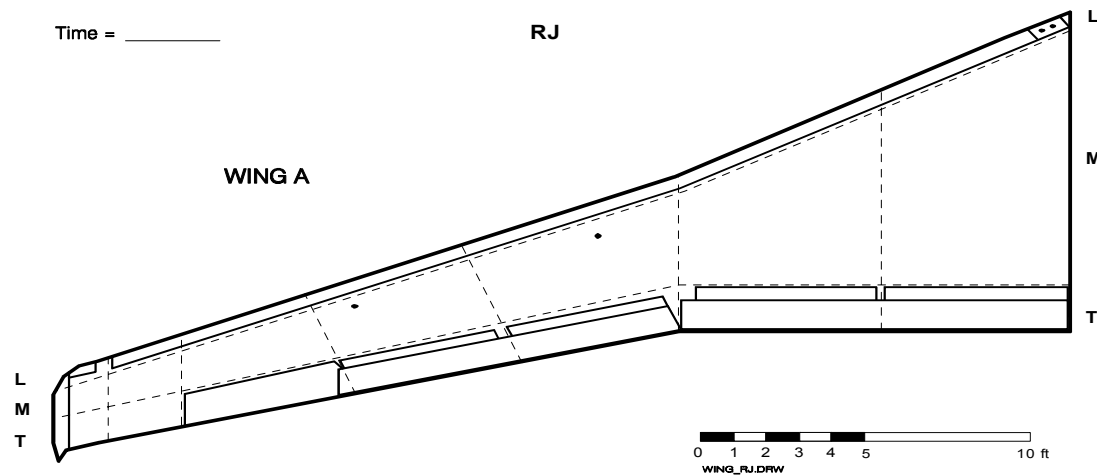
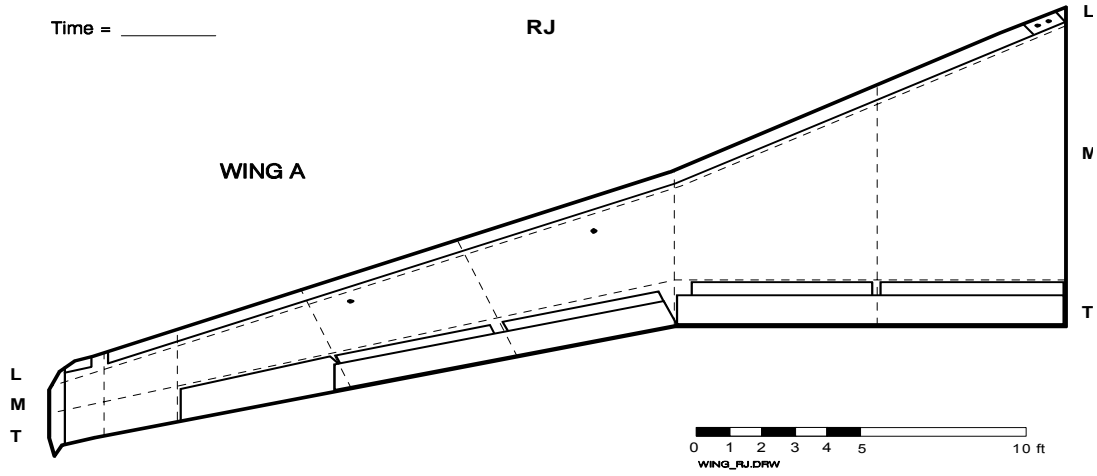

Note: To Compare to Flat Plate testing, subtract "Time of Initial Fluid Application".

FIGURE 4
DE/ANTI-ICING FORM FOR AIRCRAFT WING

REMEMBER TO SYNCHRONIZE TIME

VERSION 4.0

Winter 97/98

DATE: _____	RUN NUMBER: _____
-------------	-------------------

FAILURES CALLED BY: _____

COMMENTS: _____

HANDWRITTEN BY: _____

ASSISTED BY: _____

DRAW FAILURE CONTOURS (hr:min) ACCORDING TO THE PROCEDURE

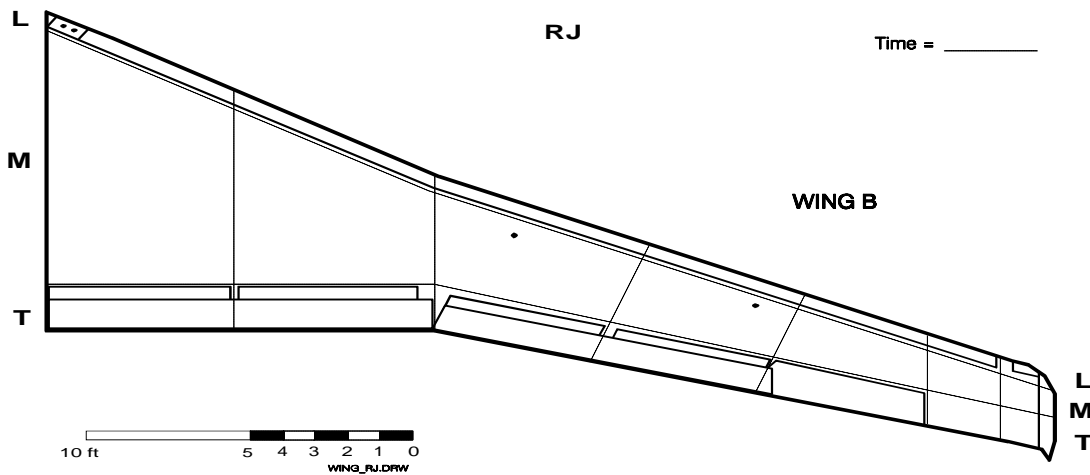
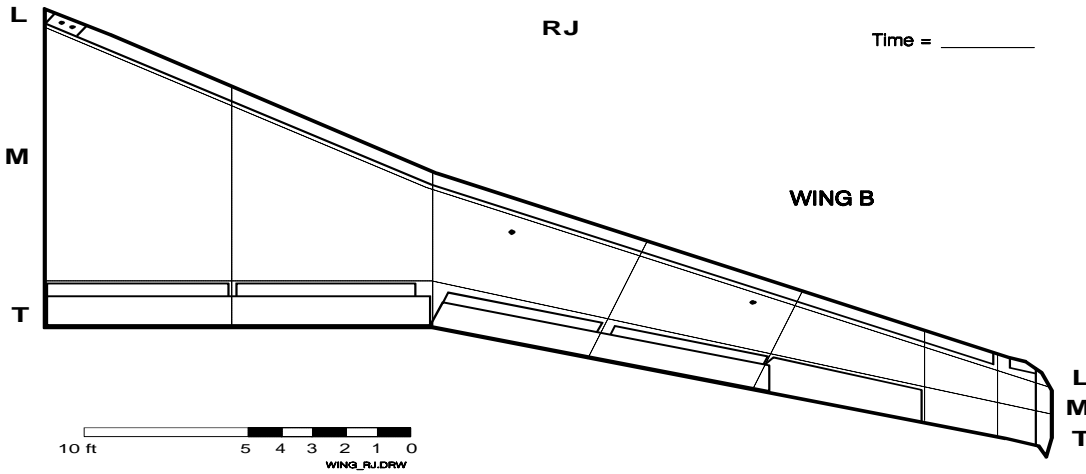
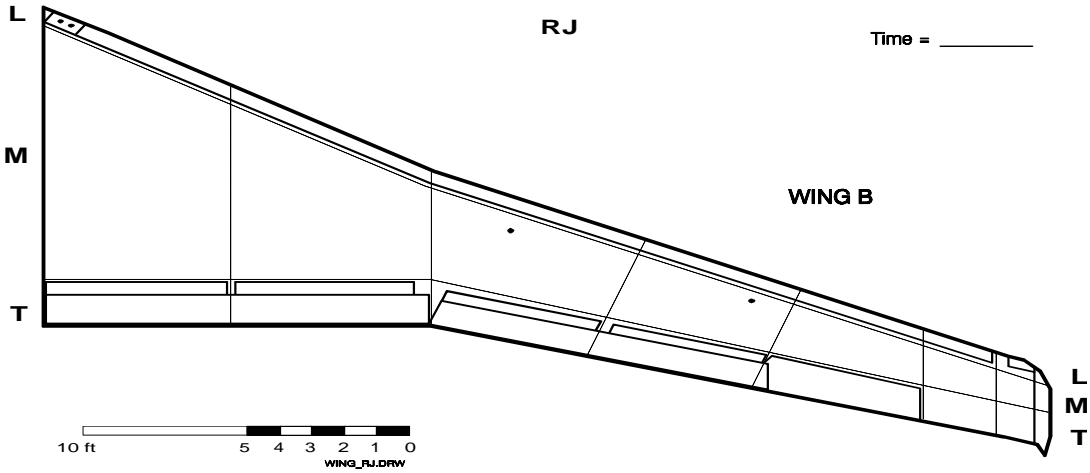

Note: To Compare to Flat Plate testing, subtract "Time of Initial Fluid Application".

FIGURE 4
DE/ANTI-ICING FORM FOR AIRCRAFT WING

REMEMBER TO SYNCHRONIZE TIME

VERSION 4.0

Winter 97/98

DATE: _____	RUN NUMBER: _____
-------------	-------------------

FAILURES CALLED BY: _____

COMMENTS: _____

HANDWRITTEN BY: _____

ASSISTED BY: _____

DRAW FAILURE CONTOURS (hr:min) ACCORDING TO THE PROCEDURE

Time: _____

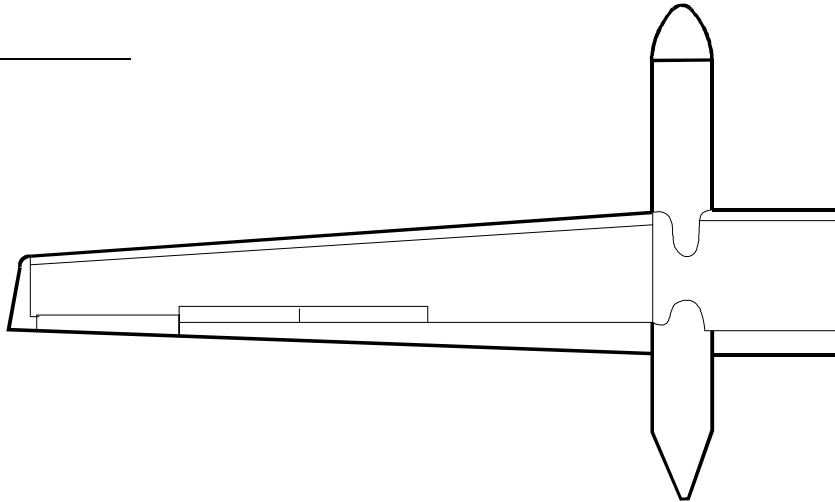

Time: _____

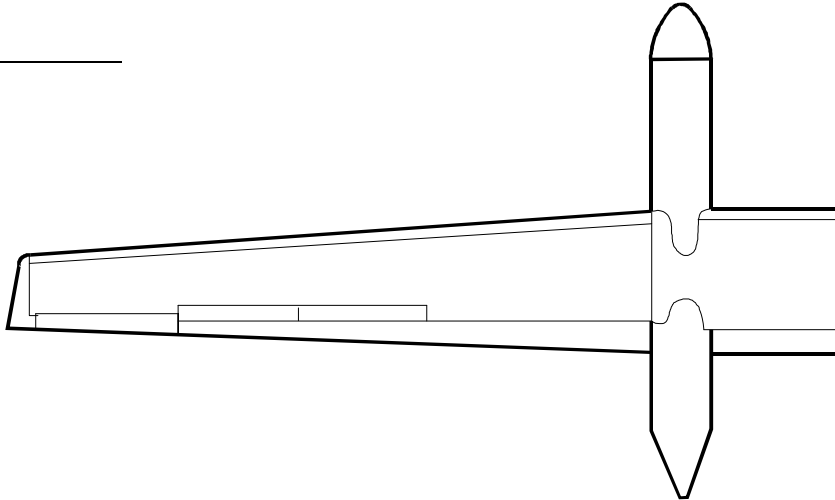

Time: _____

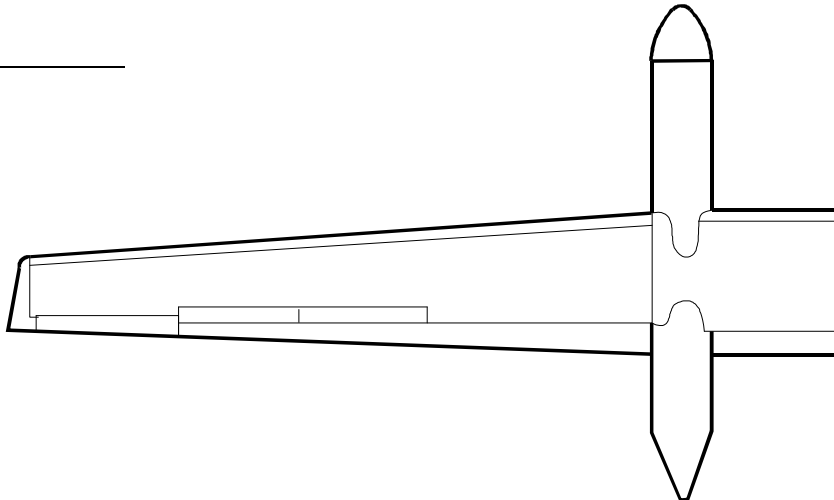

FIGURE 4
DE/ANTI-ICING FORM FOR AIRCRAFT WING

REMEMBER TO SYNCHRONIZE TIME

VERSION 4.0

Winter 97/98

DATE: _____	RUN NUMBER: _____
-------------	-------------------

FAILURES CALLED BY: _____

COMMENTS: _____

HANDWRITTEN BY: _____

ASSISTED BY: _____

DRAW FAILURE CONTOURS (hr:min) ACCORDING TO THE PROCEDURE

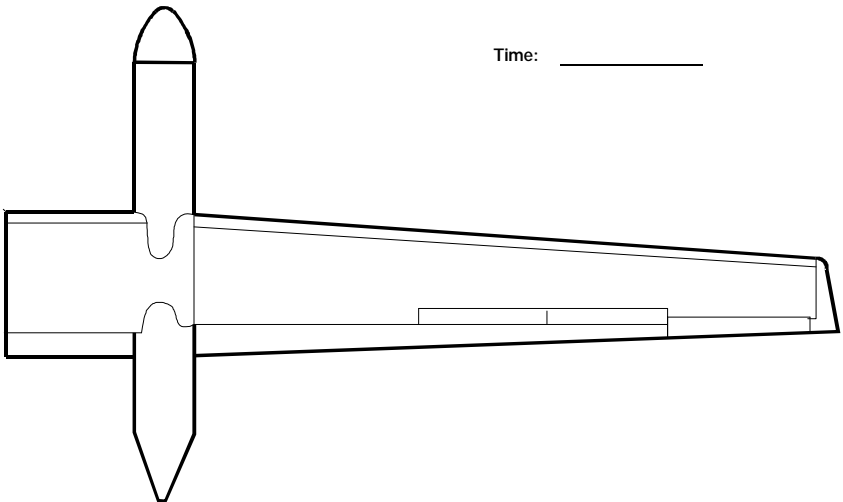
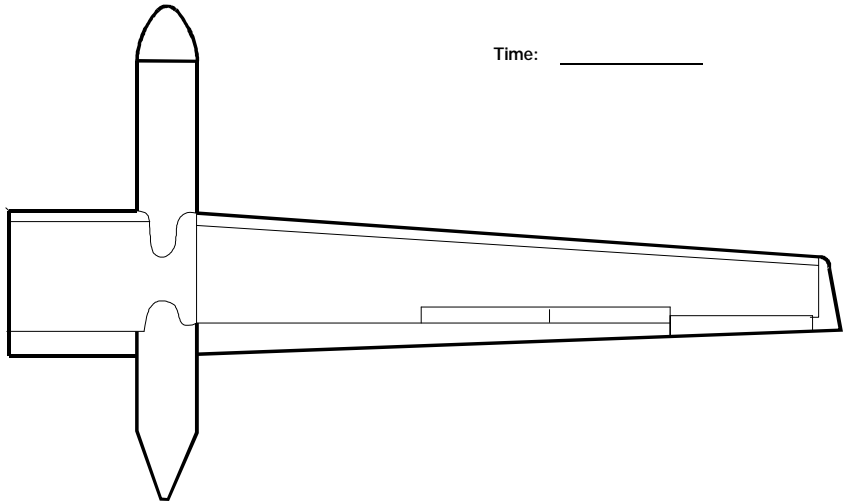
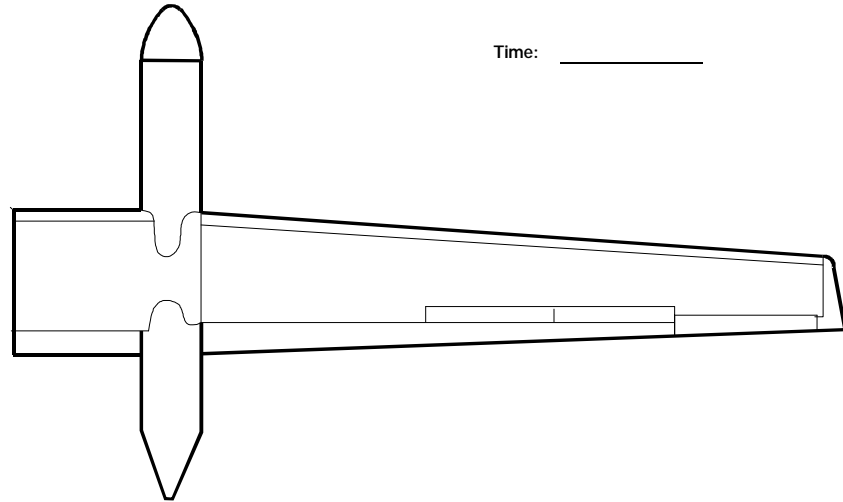

Note: To Compare to Flat Plate testing, subtract "Time of Initial Fluid Application".

FIGURE 4
DE/ANTI-ICING FORM FOR AIRCRAFT WING

REMEMBER TO SYNCHRONIZE TIME

VERSION 4.0

Winter 97/98

DATE: _____	RUN NUMBER: _____
-------------	-------------------

FAILURES CALLED BY: _____

COMMENTS: _____

HANDWRITTEN BY: _____

ASSISTED BY: _____

DRAW FAILURE CONTOURS (hr:min) ACCORDING TO THE PROCEDURE

ATR 42

Time = _____

WING A

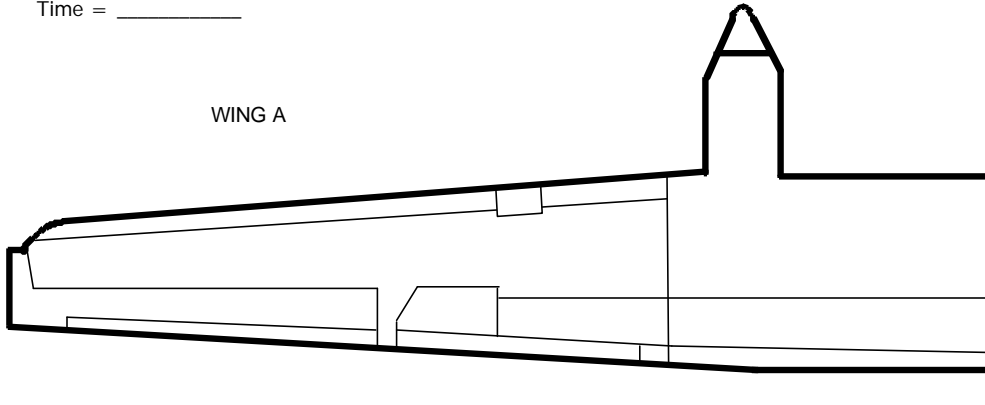

ATR 42

Time = _____

WING A

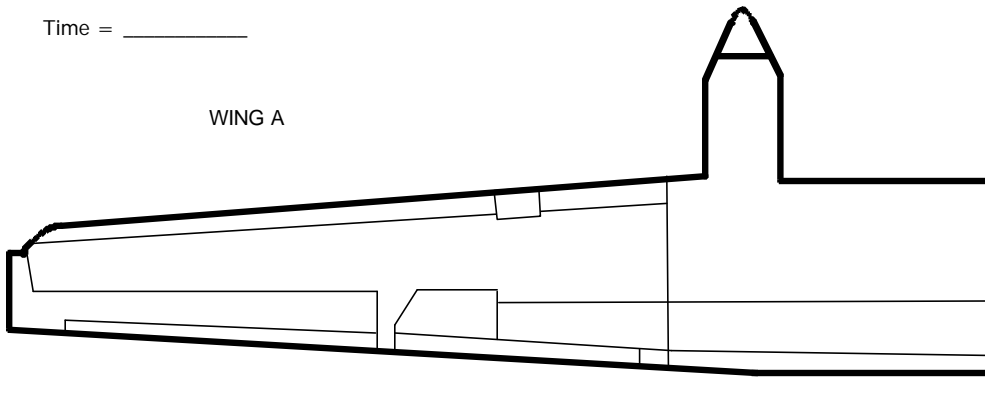

ATR 42

Time = _____

WING A

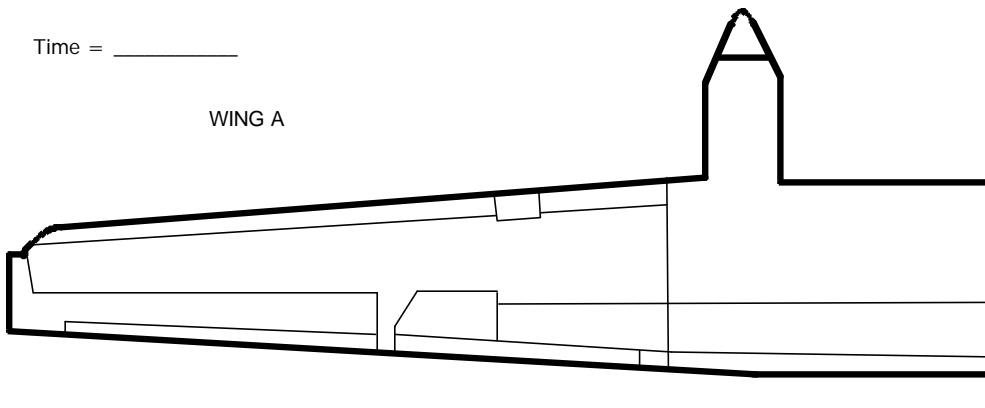

FIGURE 4
DE/ANTI-ICING FORM FOR AIRCRAFT WING

REMEMBER TO SYNCHRONIZE TIME

VERSION 4.0

Winter 97/98

DATE: _____	RUN NUMBER: _____
-------------	-------------------

FAILURES CALLED BY: _____

COMMENTS: _____

HANDWRITTEN BY: _____

ASSISTED BY: _____

DRAW FAILURE CONTOURS (hr:min) ACCORDING TO THE PROCEDURE

ATR 42

Time = _____

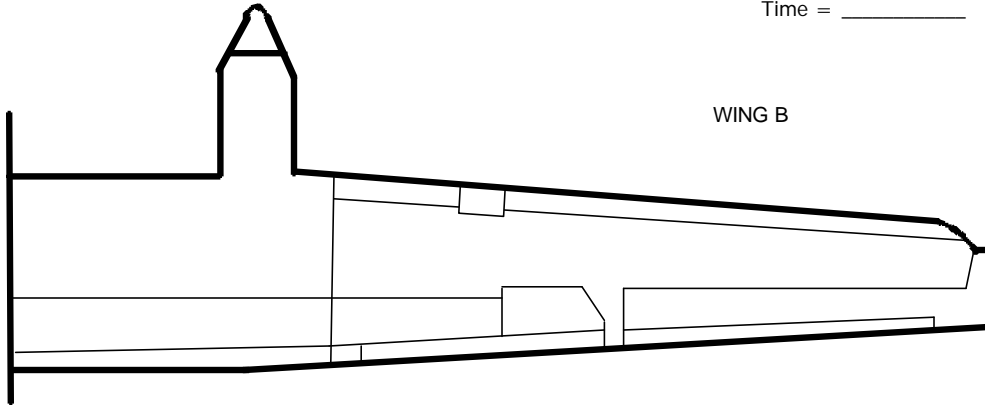

ATR 42

Time = _____

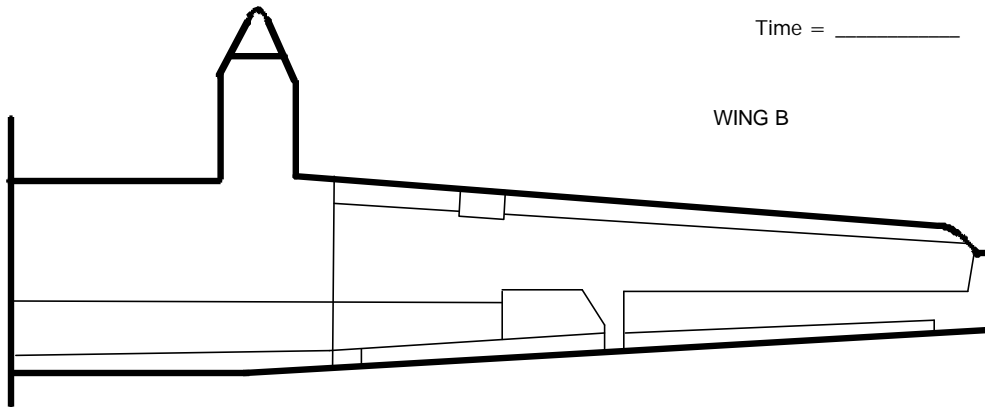

ATR 42

Time = _____

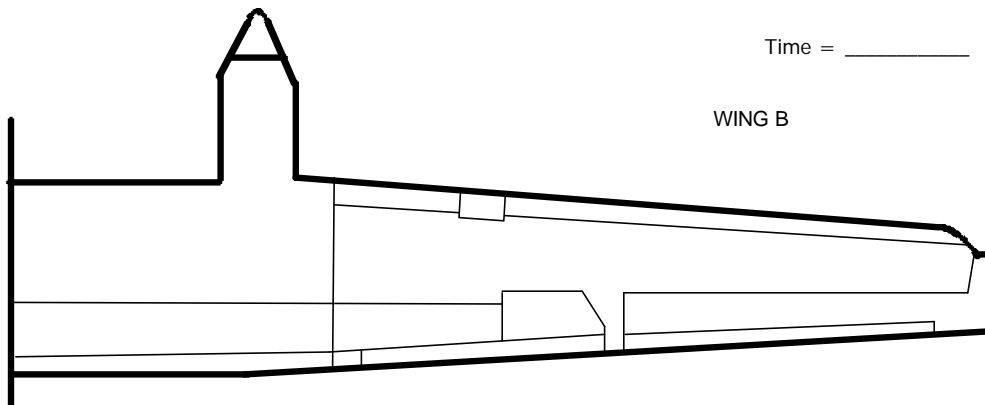

FIGURE 5 FLUID THICKNESS ON AIRCRAFT

AIRPORT: YUL YYZ YOW

AIRCRAFT TYPE: ATR 42 F100 B-737 RJ DHC-8

DATE: _____

WING: PORT (A) STARBOARD (B)

RUN #: _____

DRAW DIRECTION OF WIND WRT WING:



DIRECTION OF AIRCRAFT: _____ DEGREES

1st FLUID APPLICATION	
Actual Start Time: _____ am / pm	Actual End Time: _____ am / pm
Amount of Fluid Sprayed: _____ L / gal	Type of Fluid: _____
2nd FLUID APPLICATION	
Actual Start Time: _____ am / pm	Actual End Time: _____ am / pm
Amount of Fluid Sprayed: _____ L / gal	Type of Fluid: _____

Location	Time	Gauge	Time	Gauge	Time	Gauge	Time	Gauge	Time	Gauge
1										
2										
3										
4										
5										
6										
7										
8										
9										
10										

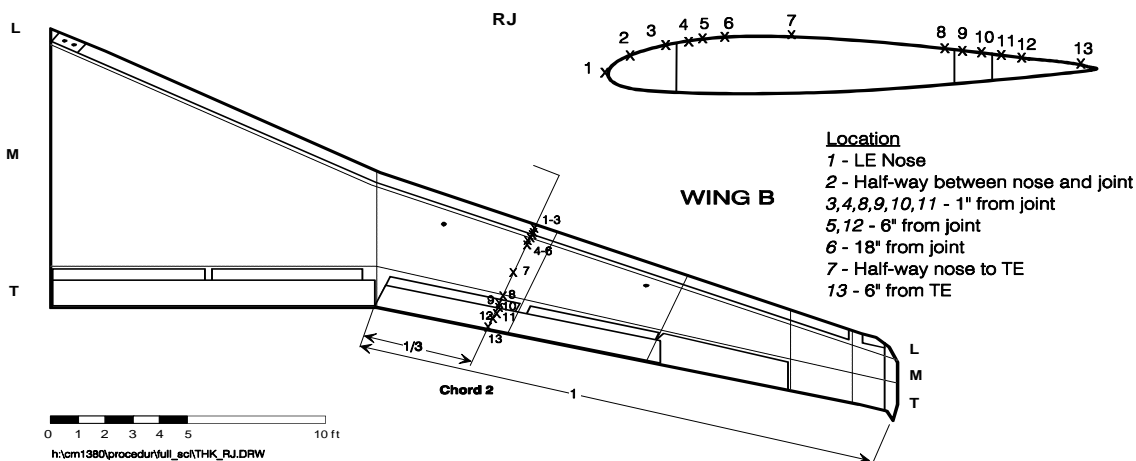

COMMENTS: _____

MEASUREMENTS BY: _____

HAND WRITTEN BY: _____

FIGURE 6
FLUID THICKNESS ON FLAT PLATES

DATE: _____
 RUN NUMBERS: _____
 LOCATION: YUL

OAT (°C): _____
 PERFORMED BY: _____
 WRITTEN BY: _____

THICKNESS (mil)									
Plate:			Fluid:			Plate:		Fluid:	
Fluid Application Time:				Fluid Application Time:					
TIME	1" LINE	6" LINE	12" LINE	TIME	1" LINE	6" LINE	12" LINE		

TABLE 1

REMEMBER TO SYNCHRONIZE TIME WITH AES - USE REAL TIME

END CONDITION DATA FORM

VERSION 5.0

Winter 97/98

LOCATION: _____	DATE: _____	RUN # : _____	STAND # : _____
------------------------	--------------------	----------------------	------------------------

RVSI Series # : _____

CIRCLE SENSOR PLATE: **u v w x y z**

SENSOR NAME: _____

DIRECTION OF STAND: °

OTHER COMMENTS (Fluid Batch, etc):

PRINT

SIGN

FAILURES CALLED BY : _____

HAND WRITTEN BY : _____

TEST SITE LEADER : _____

***TIME (After Fluid Application) TO FAILURE FOR INDIVIDUAL CROSSHAIRS (hr:min)**

Time of Fluid Application: _____ hr:min (U & X) _____ hr:min (V & Y) _____ hr:min (W & Z)

		Plate U	Plate V	Plate W
FLUID NAME				
B1 B2 B3				
C1 C2 C3				
D1 D2 D3				
E1 E2 E3				
F1 F2 F3				
TIME TO FIRST PLATE FAILURE WITHIN WORK AREA				
CALCULATED FAILURE TIME (MINUTES)				
BRX AT FAILURE				

		Plate X	Plate Y	Plate Z
FLUID NAME				
B1 B2 B3				
C1 C2 C3				
D1 D2 D3				
E1 E2 E3				
F1 F2 F3				
TIME TO FIRST PLATE FAILURE WITHIN WORK AREA				
CALCULATED FAILURE TIME (MINUTES)				
BRX AT FAILURE				

TABLE 2
METEO/PLATE PAN DATA FORM

REMEMBER TO SYNCHRONIZE TIME WITH AES - USE REAL TIME

VERSION 5.0

Winter 97/98

LOCATION:	DATE:	RUN # :	STAND # :
HAND HELD VIDEO CASSETTE #:			

PLATE PAN WEIGHT MEASUREMENTS *

PAN #	t TIME BEFORE (hh:mm:ss)	BUFFER TIME Seconds	t TIME AFTER (hh:mm:ss)	BUFFER TIME Seconds	w WEIGHT BEFORE (grams)	w WEIGHT AFTER (grams)	COMPUTE RATE ($\Delta w \times 4.7 \div \Delta t$) (g/dm ² /h)

METEO OBSERVATIONS **

TIME (hr:min)	TYPE (Fig. 4) ZR, ZL, S, SG IP, IC, BS, SP	CLASSIF. (See Fig. 3)	If SNOW, WET or DRY

**observations at beginning, end, and every 10 min. intervals. Additional observations when there are significa

TEMPERATURE AT START OF TEST _____ °C

WIND SPEED AT START OF TEST _____ kph

WIND DIRECTION AT START OF TEST _____ °

COMMENTS : _____

PRINT SIGN

WRITTEN & PERFORMED BY : _____

VIDEO BY : _____

TEST SITE LEADER : _____

*measurements every 15 min. and at failure time of each test panel.

THREE VIEW DRAWING Canadair RJ

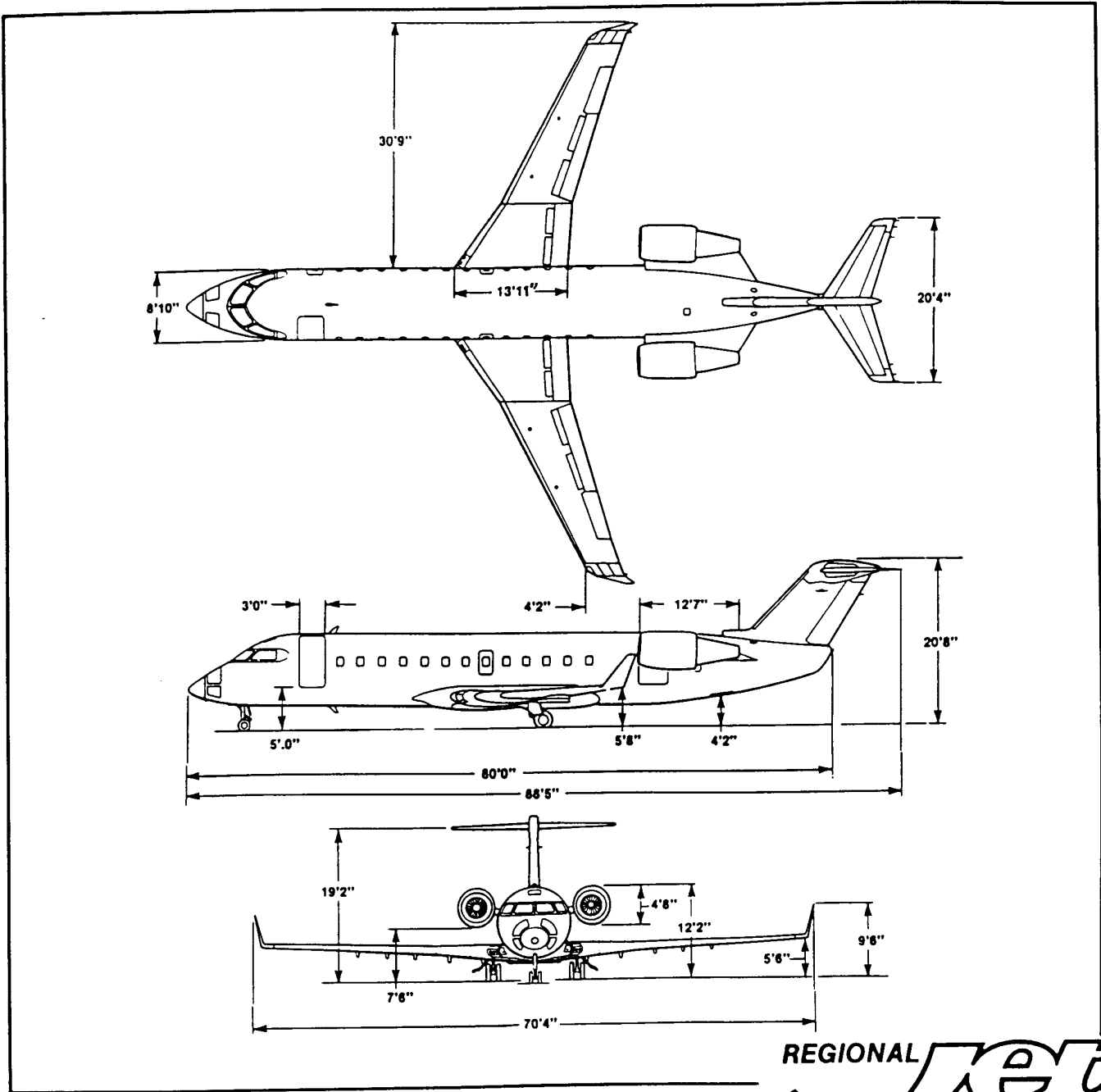

All data presented in this document are strictly based on preliminary estimates.
 Canadair does not make or intend to make any commitment, representation, or warranties whatsoever.
 All data subject to change without prior notice by Canadair.



Litho Canada

THREE VIEW DRAWING

De Havilland Dash 8

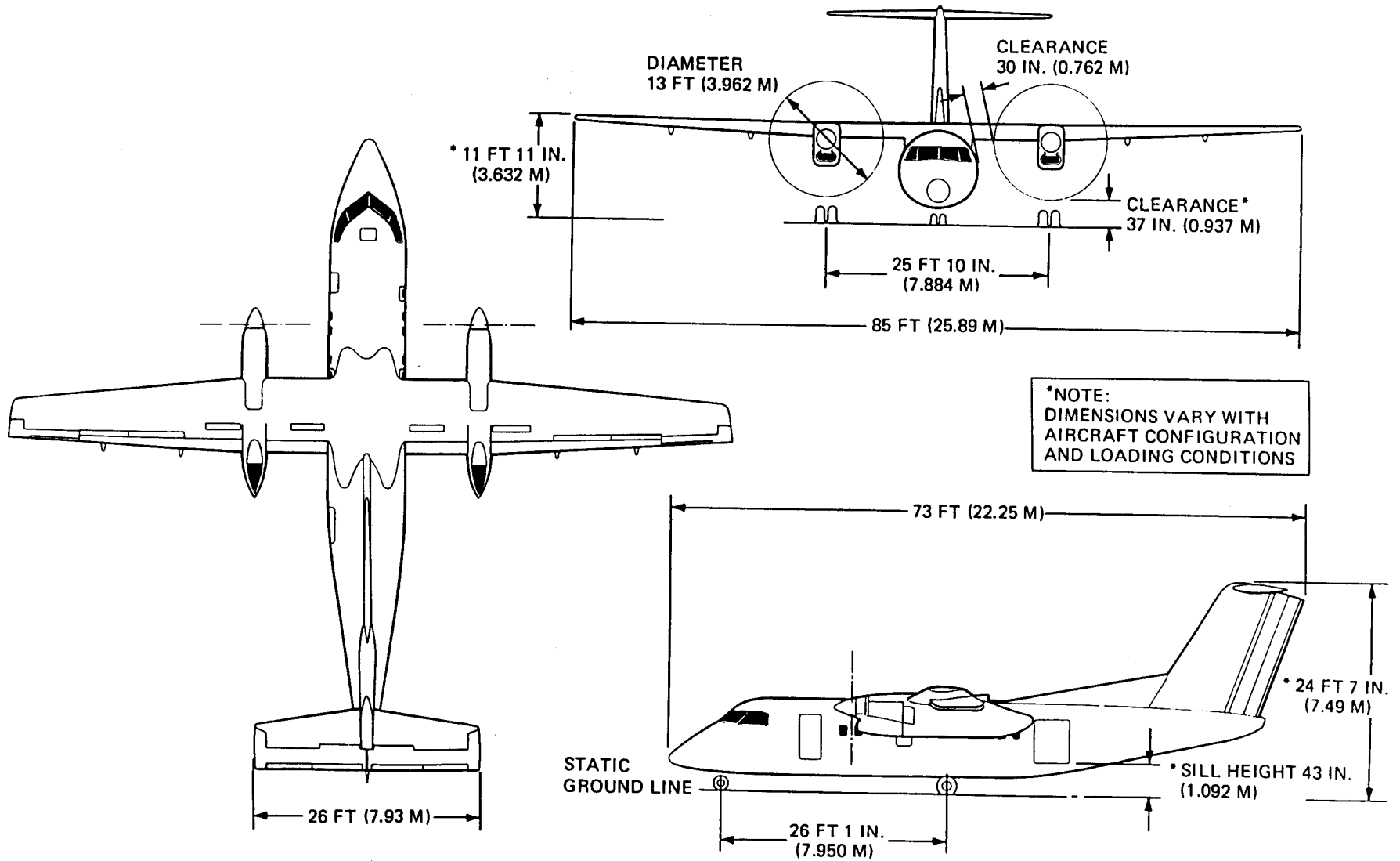

THREE VIEW DRAWING ATR 42

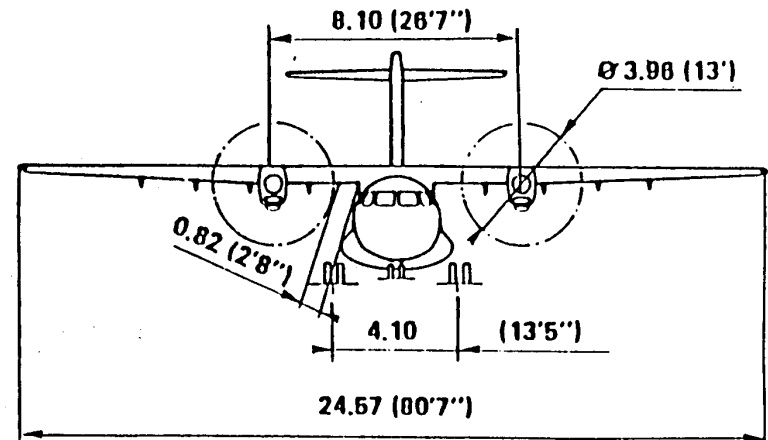
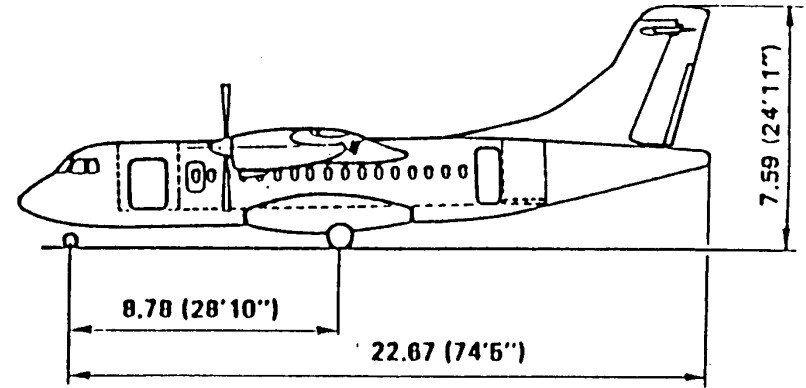
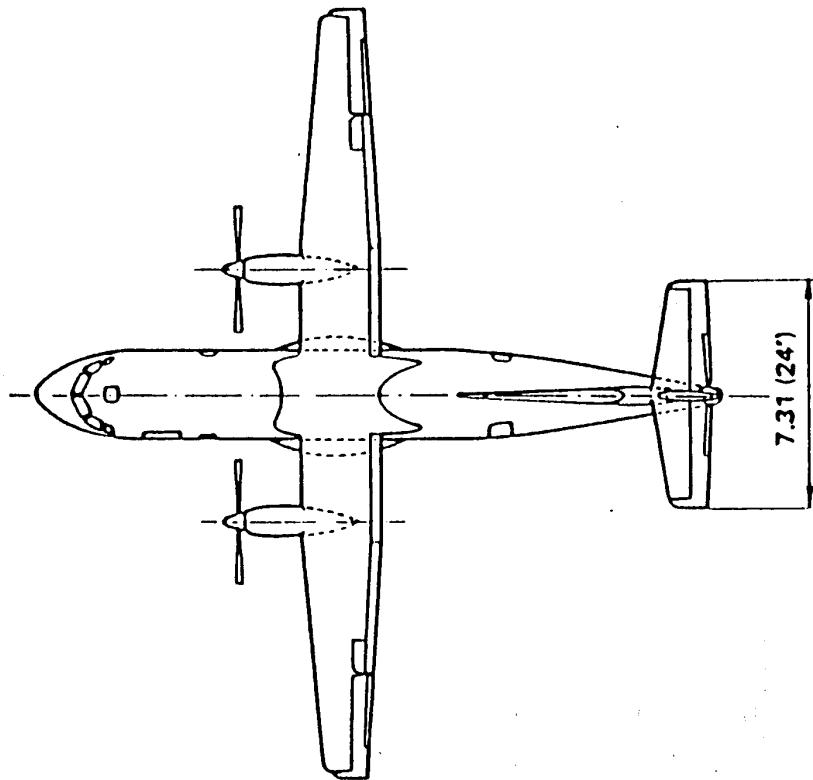

DIMENSIONS : M (ft)

APPENDIX C

REPORT

HYDRATION OF ANTI-ICING FLUID IN FROST CONDITIONS

1. INTRODUCTION

Hydration of an anti-icing fluid means that the fluid has absorbed water.

This preliminary exploratory research is based on concerns of phenomenon affecting an overnighting aircraft treated with propylene anti-icing fluid (anti icing fluid applied to an aircraft the night before a scheduled flight). During rotation, the flight crew experienced noticeable flight surface control resistance.

One suggestion was that hydration of the anti-icing fluid through active frost could alter the fluid properties and could affect flight surface functionality.

The objective of this study was to observe the behaviour of Type IV propylene fluids hydrated through active frost.

2. METHODOLOGY

2.1 Test Sites

Tests were conducted at the APS test site located at the Dorval Airport in Montreal. All tests were conducted in conditions of active frost.

2.2 Description of Test Procedures

APS monitored weather conditions on an ongoing basis throughout the test season to anticipate conditions of active frost. If these conditions were forecast, the test team was alerted 48 hours prior to the predicted event. Tests were typically scheduled to begin late evening (approximately 10:00 p.m.) and be monitored into early morning (approximately 7:00 a.m.)

Experiments were conducted in conditions of active frost. A flat plate and a rate pan were placed on a stand at a 10° slope. A second flat plate and rate pan was set-up to have a 0° slope. A premeasured one-litre volume of propylene fluid was individually applied to both the plates and the rate pans. Brix was measured on an hourly interval from fluid samples using a syringe to collect fluid from the bottom of the fluid thickness and a plastic dab for the top. Original and final samples, of the propylene fluid being applied, were collected in sample bottles and later measured for viscosity. Meteorological data including weather, temperature, dewpoint, wind speed and wind direction was retrieved from Environment Canada for each test session. The dewpoint was used to confirm the presence of frost. See Appendix C for detailed procedure.

2.3 Data Forms

The standard APS rate Brix Sampling form (Figure 1 of Appendix D) was used to document brix values, date, test start/end time, meteorological conditions and equipment in operation.

2.4 Equipment

The equipment used in this test includes a test stand, 0.31cm(1/8") aluminium flat plates, aluminium rate pans, Brixometer, Viscometer, and sample jars.

2.5 Personnel

One APS person conducted the tests.

3. DESCRIPTION AND PROCESSING OF DATA

3.1 Overview of Test Sessions

A total of eleven tests were conducted in two test sessions on January 7 and February 15 during the 1998/99 winter. Both test sessions occurred overnight, in conditions of active frost and ambient temperatures ranging from -10°C to -20°C .

3.2 Discussion of Test Variables

It was suspected that the dominant variables affecting fluid hydration include fluid type, frost rate, inclination of test surface and type of test surface (Plate or pan).

3.3 Description of Data Collected

A brix measurement was recorded every hour and changes in brix measurements were noted. Samples of fluid collected at the beginning and

end of the test were measured for viscosity. Changes in viscosity were noted.

4. ANALYSIS AND OBSERVATIONS

Test results did not suggest any unanticipated alteration in anti-icing fluid properties. On occasion, small variations in brix measurements were recorded in the magnitude of 0.5 degree. The accuracy and nature of the brixometer do not allow these variations to be conclusive.

Viscosity measurements did not record any increase in viscosity due to hydration.

These results coincide with values derived from a model showing a typical fluid thickness of 1mm and an assumed frost rate of 0.08 g/dm²/h. If the dilution of the fluid through hydration at a constant frost rate is assumed linear, the fluid should decrease by one brix degree every four hours.

5. CONCLUSIONS

Data collected throughout the test sessions does not support any evidence of fluid property alteration due to hydration by active frost.

APPENDIX D

**EXPERIMENTAL PROGRAM
HYDRATION OF ANTI-ICING FLUID IN FROST CONDITIONS**

Hydration of Anti-Icing Fluid in Frost Conditions

Winter 1998/99

Version 1.1

1. Objective

Reproduce conditions of fluid rehydration and determine extent of fluid property alteration.

2. Plan

Conduct tests in conditions of (forecasted) frost. Test should begin late evening (approximately 10:00 p.m.) and be monitored into early morning (approximately 7:00 a.m.)

3. Procedure

Experiments will be conducted at the Dorval test site in conditions of expected frost. A flat plate and a rate pan will be placed on a stand at a 10° slope. A second flat plate and rate pan will be set-up to have a 0° slope. A premeasured, one liter, volume of propylene fluid will be individually applied to both the plates and rate pans. Brix will be measured hourly from fluid samples collected, both by “dabbing” and using a syringe, from the top and bottom of the fluid layer. Original and final samples, of fluid will be collected for measurement of viscosity. Meteo data including weather, temperature, dewpoint, wind speed and wind direction are to be retrieved from Environment Canada for each test session. The dewpoint will be used to determine the frost point and confirm the presence of frost.

4. Personnel

One research assistant:

- Set up test stand, plates and rate pans
- Apply fluid to plates
- Record hourly brix values
- Collect samples for viscosity measurement

5. Form

The Brix form is shown in Figure 1. The following information should be recorded:

- Date;
- Test start/end time;
- Meteo conditions (temp, dewpoint, wind speed, and wind direction)
- Frost appearance and behavior:
- Hourly brix values
- Viscosity measurements

6. Equipment

- Refractometer
- Syringe and plastic strips
- Viscometer
- Type IV propylene Fluid
- Refer to procedure
- Sample containers
- Thermistors

APPENDIX E

FROST SELF-ELIMINATION USING LUMINOUS RADIATION

FROST SELF-ELIMINATION USING LUMINOUS RADIATION

Winter 1998/1999

1. INTRODUCTION

Alternative, more cost-effective methods of deicing are constantly being sought. Frost related deicing constitutes a substantial part of the yearly deicing efforts. APS conducted exploratory tests to evaluate an alternative method of preventing or removing frost.

1.1 Objective

The objective of this test was to determine the feasibility of using artificial lighting (luminous radiation) as a means of depressing frost formation, and to evaluate the possibilities of using luminous radiation to remove frost.

2. METHODOLOGY

2.1 Test Sites

Tests were conducted at the APS test site located at Dorval Airport. All tests were conducted overnight in conditions of active frost.

2.2 Description of Test Procedures

Frost self-elimination tests were conducted in conditions of active frost. The over-night luminous self-elimination test involved the set-up of four identical 1/8" flat plates coated with green paint (the four plates are chosen to be the same color so that the emissivity effects remain constant). Two plates (referred to as the *lighted plates*) were placed on a stand inclined at 10° and continuously exposed to the radiation effects of a 150-watt sodium light positioned 5 feet above the stand (Photo 2.0). The other two plates (referred to as the *unlighted witness plates*) were placed on a stand and not exposed to any artificial lighting. Thermistors were placed on an individual plate from each set to monitor surface temperature and confirm frost point temperatures. Rates were measured (using the preweighed, second thermistorless plate from each set) every two hours to monitor and confirm the formation of frost. Frost formation and more particularly crystal formation on the test plates were visually documented using a still camera. Elapsed video documentation was also recorded.

2.3 Data Forms

The standard APS rate form (Figure 2.0) was used to document rate of frost formation, date, test start/end time, meteo conditions, frost appearance and behaviour and equipment in operation.

2.4 Equipment

The equipment used in this test included a test stand, green painted 1/8" aluminium flat plates, 150 watt sodium light, 2 thermistor probes and 1 data logger, weigh scale, still camera and elapsed time video camera.

FIGURE 2.0
METEO/PLATE PAN DATA FORM

REMEMBER TO SYNCHRONIZE TIME WITH AES - USE REAL TIME

VERSION 6.0

Winter 98/99

LOCATION:	DATE:	RUN # :	STAND # :
HAND HELD VIDEO CASSETTE #:			

PLATE PAN WEIGHT MEASUREMENTS *

PAN #	t TIME BEFORE (hh:mm:ss)	BUFFER TIME Seconds	t TIME AFTER (hh:mm:ss)	BUFFER TIME Seconds	w WEIGHT BEFORE (grams)	w WEIGHT AFTER (grams)	COMPUTE RATE ($\Delta w * 4.7 / \Delta t$) (g/dm ² /h)

METEO OBSERVATIONS **

TIME (hr:min)	TYPE (Fig. 4) ZR, ZL, S, SG IP, IC, BS, SP	CLASSIF. (See Fig. 3)	If SNOW, WET or DRY

**observations at beginning, end, and every 10 min. intervals. Additional observations when there are significa

TEMPERATURE AT START OF TEST _____ °C
WIND SPEED AT START OF TEST _____ kph
WIND DIRECTION AT START OF TEST _____ °

COMMENTS :

PRINT SIGN
WRITTEN & PERFORMED BY : _____
VIDEO BY : _____
TEST SITE LEADER : _____

*measurements every 15 min. and at failure time of each test panel.

Photo 2.0
Two Adjacent "Lighted Plates" On Test Stand

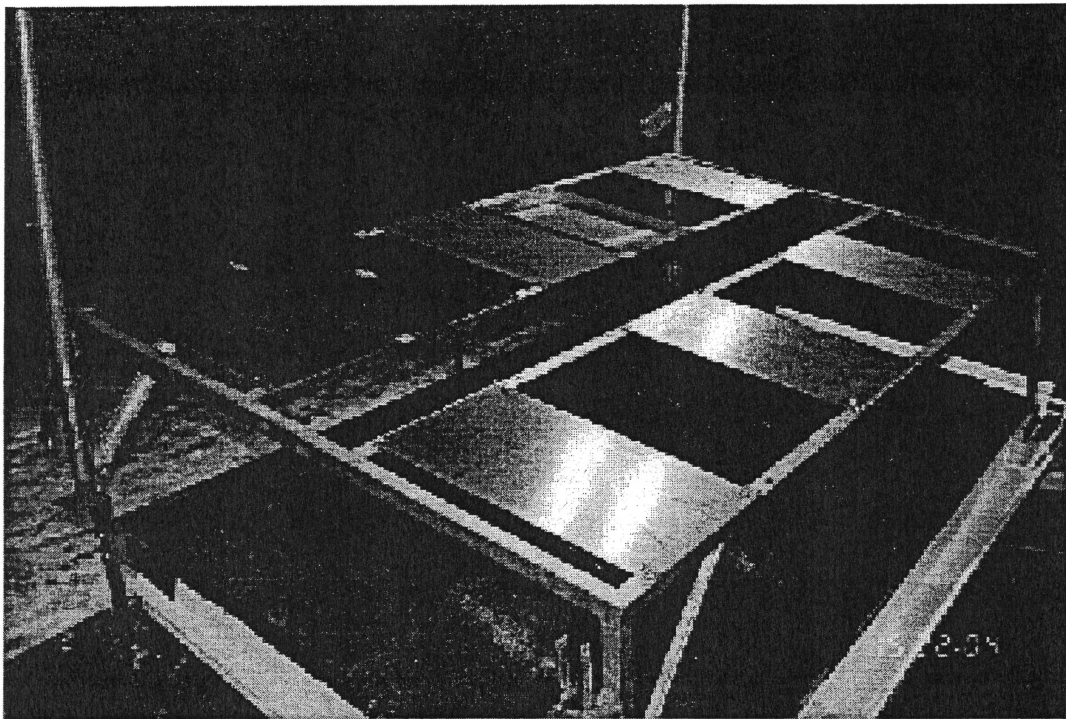

2.5 Personnel

One APS person conducted the tests. One photographer/video person recorded video and photo documentation.

3. DESCRIPTION AND PROCESSING OF DATA

3.1 Overview of Test Sessions

Two overnight tests were conducted at the APS test facility located at the Dorval Airport during conditions of active frost. The first test conducted on January 7, the second on February 14.

APS monitored weather conditions on an ongoing basis throughout the test season to anticipate conditions of active frost. If these conditions were forecast, the test team was alerted 48 hours prior to the predicted event.

Data, comments and visual documentation were collected for each test session.

3.2 Discussion of test variables

OAT and plate surface temperatures were logged for each test session. Conditions conducive to active frost formation include clear skies, calm winds, high relative humidity; OAT's below 0°C and a surface temperature lower or equal to the dew point temperature. The interplay and delicate balance of these variables was collated for one test session and is presented in figure 3.1.

These variables were later confirmed with meteorological data retrieved from Environment Canada.

It was noted that in conditions of active frost, the surface temperature is always lower than the OAT, typically by approximately three degrees.

3.3 Description of Data Collected

Surface temperatures for both the *lighted plate* and the *unlighted witness plate* were recorded and plotted against time. Figure 3.2 shows a plot of the unlighted plate temperature profile versus the OAT temperature profile. Temperature of the lighted plate was recorded but could not be retrieved. The frost deposits were measured by weighing the two test surfaces on a two-hour interval. Deposition rates were calculated by dividing the difference between the prior and subsequent end weights of the test surfaces (in grams) by the number of hours that the surfaces were exposed to frost conditions. The result was then divided by the area of the test surface in (dm²). Frost deposition is expressed in g/dm²/hr.

Meteorological data retrieved from Environment Canada was used to confirm active frost.

FIGURE 3.1

Meteorological Profile of Test Session

FEB 14-15

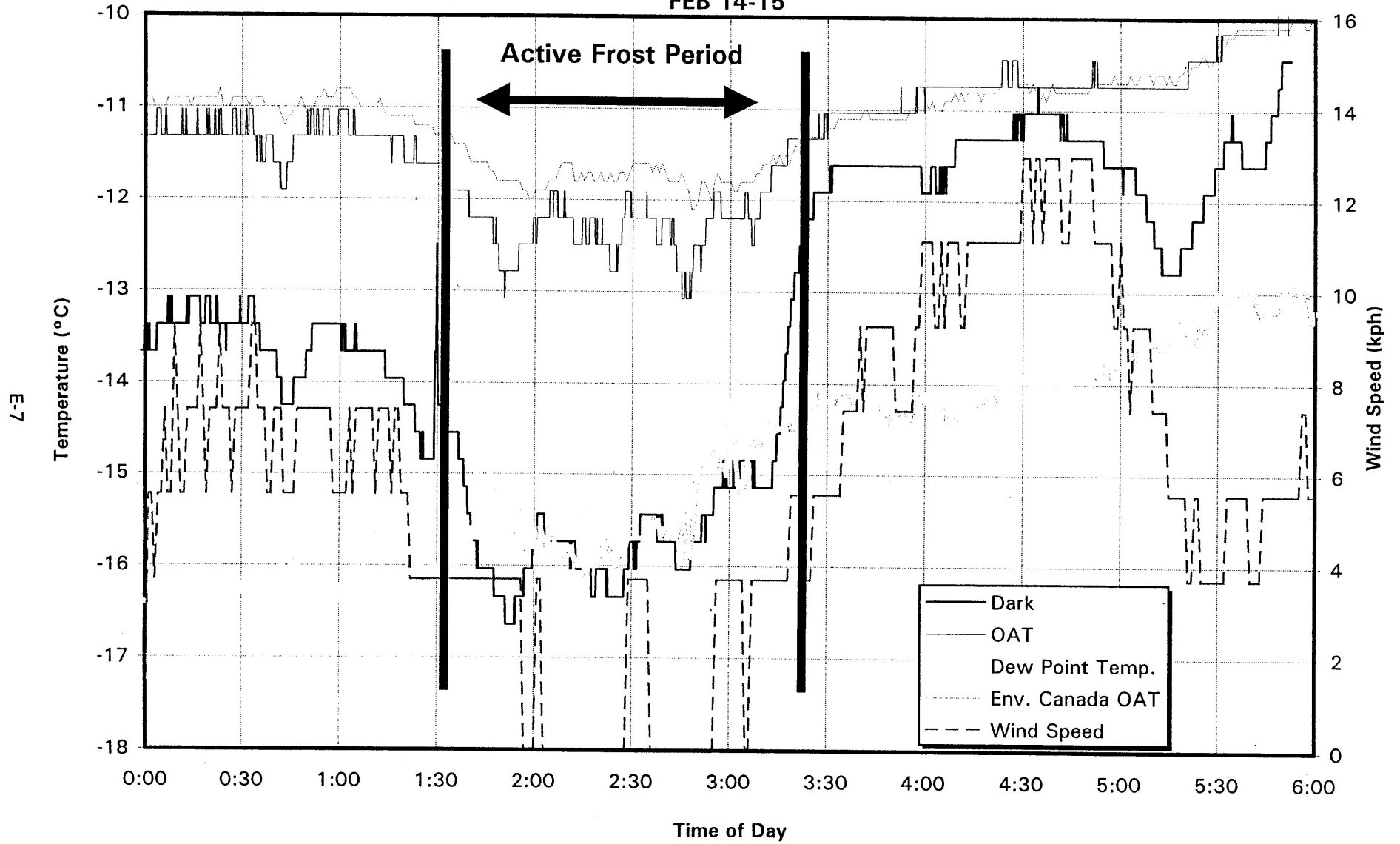
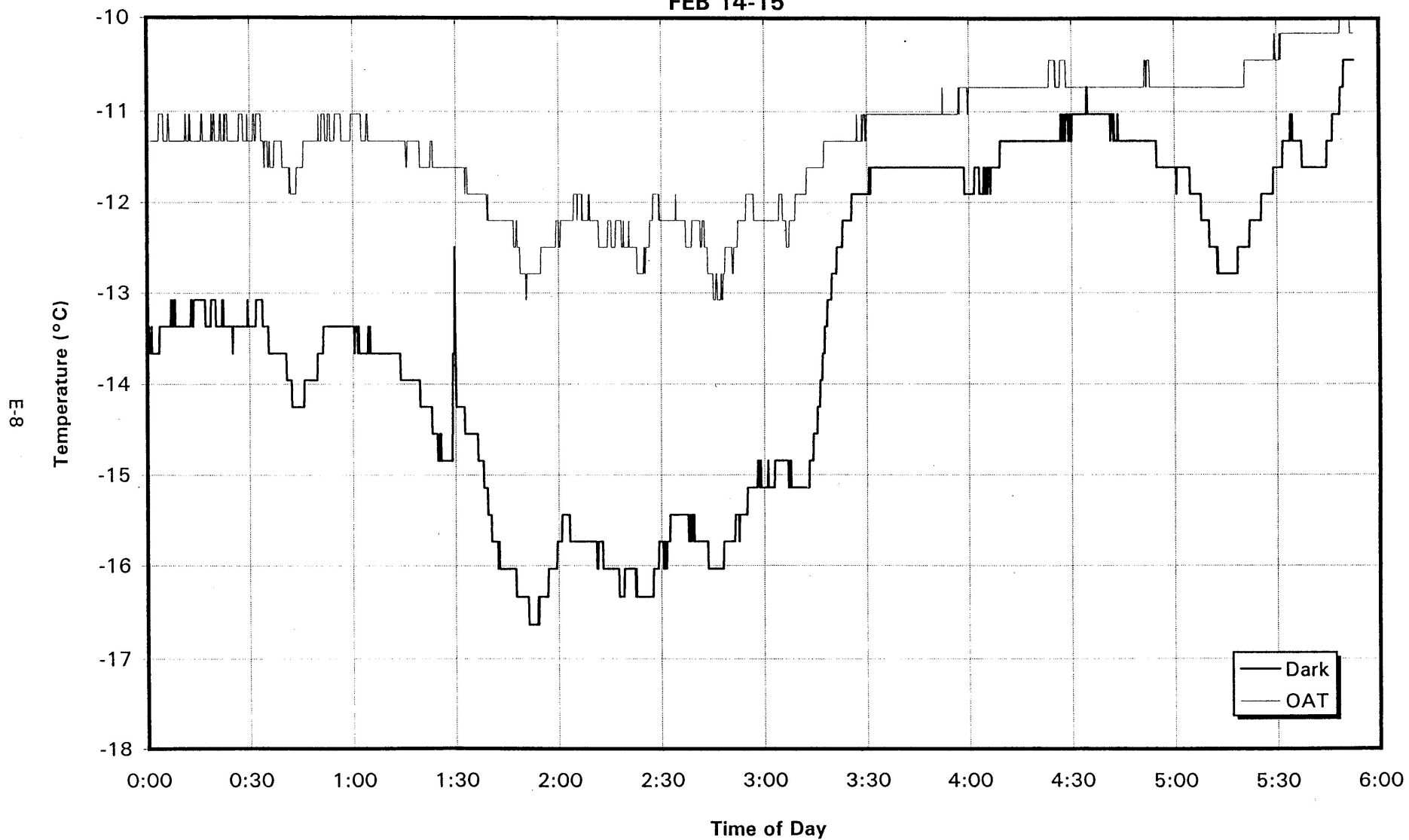

FIGURE 3.2

Unlighted Plate Surface Temperature vs OAT

FEB 14-15



E-8

Dark
OAT

4. ANALYSIS AND OBSERVATIONS

Two overnight luminous self-elimination tests involving four identical 1/8" flat plates coated with green paint were conducted on January 7 and February 14.. The two plates were exposed to artificial lighting two were not. The temperature of the *lighted plate* was observed to be predominantly warmer by approximately two degrees. The lighted and unlighted plates were consistently colder than the OAT. The temperature range for January 7 and February 14 were -23°C to -16°C and -16.5°C to -11°C , respectively. It appeared over all that the luminous radiation was sufficient to raise the *lighted plate* temperature. This increase in temperature was small, but significant enough to completely depress and retard the formation of frost at the beginning of the test. At the beginning of the test and for a short period after, the *unlighted witness plate* was experiencing significant frost formation and the *lighted plate* was not. As the "retarded " period ended and frost began to form on the *lighted plate*, it was noted that the shapes of the crystal formations on the *lighted plate* were different than those on the *unlighted witness plate*. More specifically, the *lighted plate* showed needle like formations (Photo 4.0), whereas the *unlighted witness plate* showed mostly spherical or granular formations (Photo 4.1). This observation suggests that the effect of radiation was still existent after the "retarded" period ended and continued to momentarily depress frost formation. The spherical or granular shapes suggest instantaneous freezing of the water vapour upon contact, whereas the needle like formations suggests freezing only after contact. Otherwise stated the water droplet is allowed to form, dissipate and then freeze.

The effects the different formations had on adherence were not evaluated.

On one occasion, the period of active frost stopped when the initially clear sky became overcast. The existing frost was eliminated. On this occasion, the "retarded" period on the "lighted plate" was complimented by an "accelerated" period. This is to say that the elimination of frost on the "lighted plate" occurred substantially quicker then that of the "unlighted witness plate".

The measured rates for the "unlighted witness plates" were predominantly higher in comparison to the "lighted plate". During the "retarded" period no rate of formation was measured (the rate was zero).

Photo 4.0
Needle Shaped Frost Formations on "Lighted Plate"

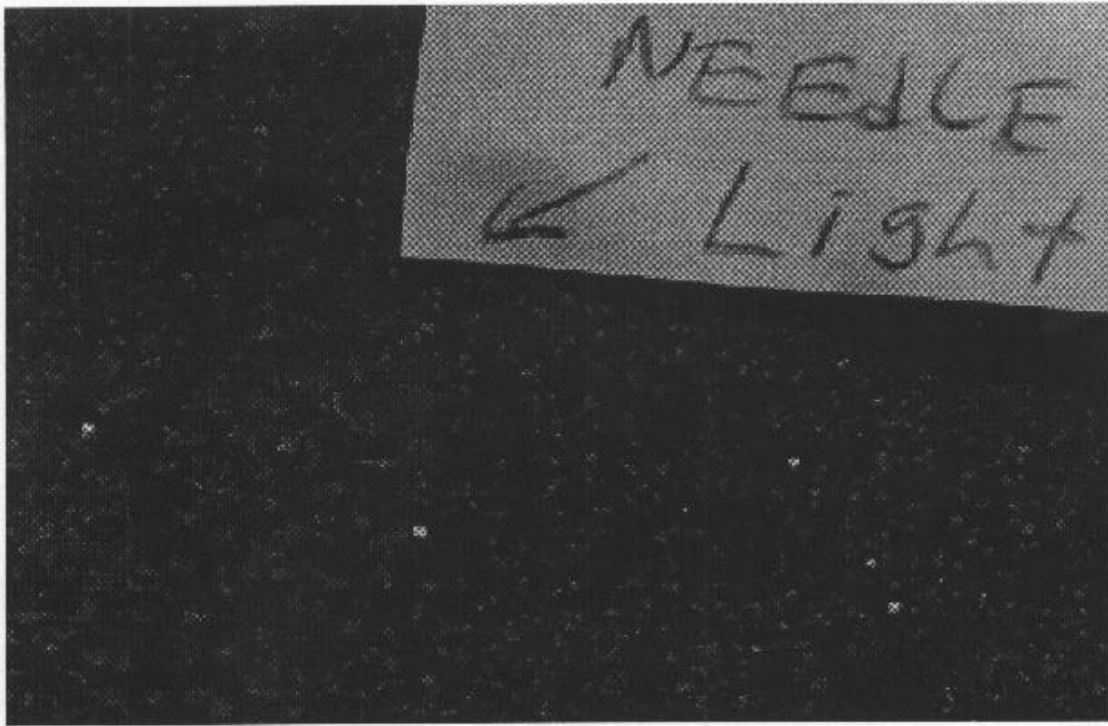
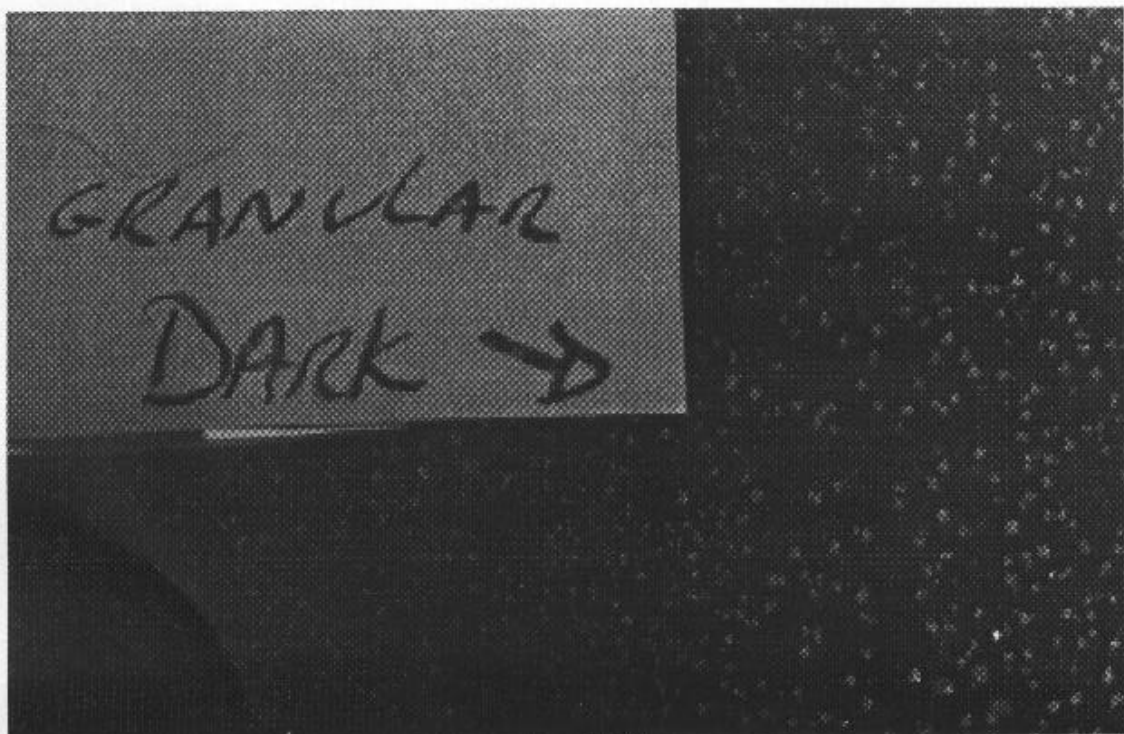

Photo 4.1
Granular Shaped Frost Formation on "Dark Plate"



5. CONCLUSION

Effects of luminous radiation were observed and may prove to be a viable method of frost elimination

6. RECOMMENDATIONS

It is recommend to:

- Repeat tests using mast lighting;
- Include a measure of adherence into procedure;
- Repeat tests in warmer temperatures (0°C - -10°C): it is suspected that this is the range where luminous radiation will be most effective;
- Introduce the use of the RH meter in the immediate stand area (log continuously);
- Obtain values of Solar Radiation from Environment Canada (pyronometer);
- Create an outdoor rate station to avoid the negative destabilising effects of having to bring the plates indoors;
- Measure rates on a smaller, one hour interval; and
- Introduce different coloured plates to evaluate effects of emmissivity.