

Deicing with a Mobile Infrared System

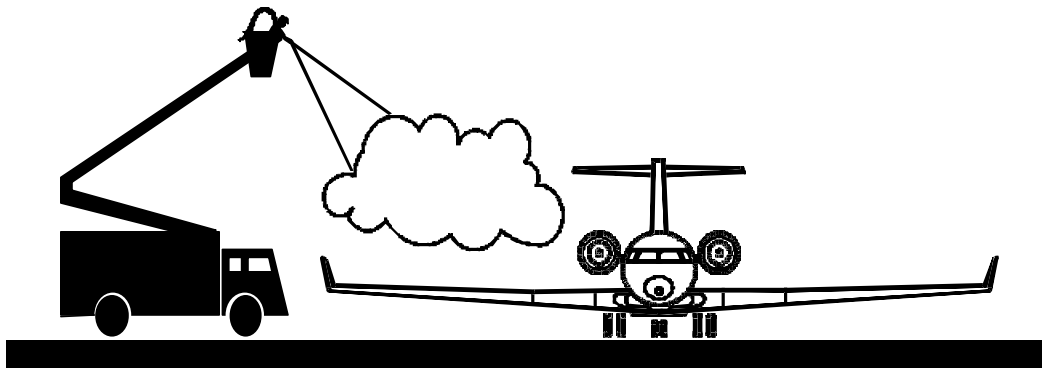

Prepared for
Transportation Development Centre
on behalf of
Civil Aviation
Transport Canada

by

APS AVIATION INC. **APS**

December 1998

Deicing with a Mobile Infrared System

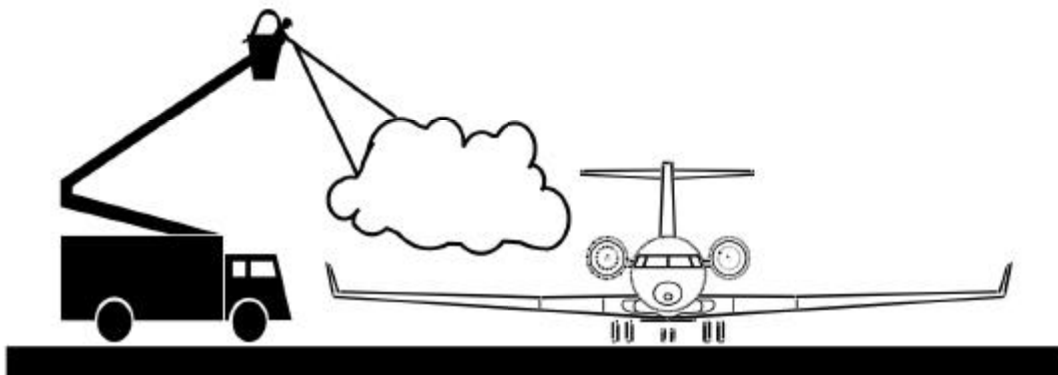

by

Elio Ruggi and
Cassia Pole

APS AVIATION INC. **APS**



December 1998

The contents of this report reflect the views of APS Aviation Inc. and not necessarily the official view or opinions of the Transportation Development Centre of Transport Canada.

The Transportation Development Centre does not endorse products or manufacturers. Trade or manufacturers' names appear in this report only because they are essential to its objectives.

DOCUMENT ORIGIN AND APPROVAL RECORD

Prepared by: Elio Ruggi and Cassia Pole

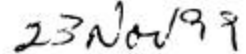
Reviewed by:		
	Gilles Bourret, Eng. Director, Business Development	Date
Approved by:		
	R.V. Potter, PhD Vice-President Programs & QA	Date

ACKNOWLEDGEMENTS

The authors gratefully acknowledge the contribution of the data collection and research team: Nick Blais, Mike Chaput, John D'Avirro, Medhat Hanna, Jeff Mayhew, and Anthoni Peters. Special thanks are extended to Frank Eyre and Barry Myers of the Transportation Development Centre for their participation, contribution, and guidance provided in the preparation of this document.

Un sommaire français se trouve avant la table des matières.

PREFACE

At the request of the Transportation Development Centre of Transport Canada, APS Aviation Inc. has undertaken a research program to further advance aircraft ground deicing/anti-icing technology. Specific objectives of the APS test program were:

- To develop holdover time tables for new Type IV fluids and to validate *fluid-specific* tables and SAE tables;
- To determine the influence of fluid type, precipitation, and wind on location and time to fluid failure initiation, and also failure progression on the Canadair Regional Jet and on high-wing turboprop commuter aircraft;
- To establish experimental data sufficient to support development of a *deicing only* table to serve as an industry guideline, and to evaluate freeze point temperature limits for fluids used as the first step of a two-step deicing operation;
- To establish conditions for which contamination due to anti-icing fluid failure in freezing precipitation fails to flow from the wing of a jet transport aircraft when subjected to rotation speeds;
- To document the appearance of fluid failure and the characteristics of the fluid at time of failure, through conduct of a series of trials on standard flat plates;
- To determine the feasibility of examining the condition of aircraft wings prior to takeoff through use of ice contamination sensor systems; and
- To explore the effectiveness of the ICE CAT system in removing different types of frozen contamination from a wing surface.

The research activities of the program conducted on behalf of Transport Canada during the 1997/98 winter season are documented in separate reports. The titles of these reports are as follows:

- TP 13318E Aircraft Ground De/Anti-icing Fluid Holdover Time Field Testing Program for the 1997/98 Winter;
- TP 13314E Research on Aircraft Deicing Operations for the 1997/98 Winter;
- TP 13315E Aircraft Deicing Fluid Freeze Point Buffer Requirements: *Deicing Only* and First Step of Two-Step Deicing;

- TP 13316E Contaminated Aircraft Takeoff Test for the 1997/98 Winter;
- TP 13317E Characteristics of Aircraft Anti-Icing Fluids Subjected to Precipitation; and
- TP 13489E Deicing with a Mobile Infrared System.

This report, TP 13489E, addresses the following objective:

- To explore the effectiveness of a mobile infrared deicing system for the removal of different types of frozen contamination from wing surfaces.

These objectives were met primarily by conducting field trials at Dorval Airport.

This research has been funded by the Civil Aviation Group, Transport Canada. This program of research could not have been accomplished without the participation of many organizations. APS would therefore like to thank the Transportation Development Centre of Transport Canada, the Federal Aviation Administration, US Airways Inc., the National Research Council Canada, Atmospheric Environment Services, Transport Canada, and the fluid manufacturers for their contributions to, and assistance with the program. Special thanks are extended to Infra-Red Technologies Inc., US Airways Inc., Air Canada, the National Research Council Canada, Canadian Airlines International, Inter-Canadien, AéroMag 2000, Aéroport de Montreal, RVSI, Cox and Company Inc., KnightHawk, and Shell Aviation for provision of personnel and facilities, and for their co-operation on the test program. Union Carbide, Octagon, SPCA, Kilfrost, Clariant, and Inland Technologies Inc. are thanked for provision of fluids for testing. APS would also like to acknowledge the dedication of the research team, whose performance was crucial to the acquisition of hard data leading to the preparation of this document.



1. Transport Canada Publication No. TP 13489E		2. Project No. 9326 (DC 161)		3. Recipient's Catalogue No.	
4. Title and Subtitle Deicing with a Mobile Infrared System				5. Publication Date December 1998	
				6. Performing Organization Document No.	
7. Author(s) Elio Ruggi and Cassia Pole				8. Transport Canada File No. ZCD2450-B-14	
9. Performing Organization Name and Address APS Aviation Inc. 1100 René Lévesque Blvd. West Suite 1340 Montreal, Quebec H3B 4N4				10. PWGSC File No. XSD-7-01411	
				11. PWGSC or Transport Canada Contract No. T8200-7-7557	
12. Sponsoring Agency Name and Address Transportation Development Centre (TDC) 800 René Lévesque Blvd. West Suite 600 Montreal, Quebec H3B 1X9				13. Type of Publication and Period Covered Final	
				14. Project Officer Barry B. Myers	
15. Supplementary Notes (Funding programs, titles of related publications, etc.) <p>Research reports produced on behalf of Transport Canada for testing during previous winters are available from the Transportation Development Centre (TDC). Six reports (including this one) were produced as part of this winter's research program (1997-98). Their subject matter is outlined in the preface. Equipment and equipment operation expenses were provided by Infra-Red Technologies Inc.</p>					
16. Abstract <p>The project's primary objective was to explore the effectiveness of a mobile infrared deicing system for the removal of different types of frozen contamination from wing surfaces.</p> <p>The effectiveness of the ICE CAT mobile infrared deicing system was evaluated on two consecutive nights. Wet snow occurred on the first night of trials. On the second night, simulated freezing rain was applied to the wing surface. The ICE CAT heater panel was positioned over the contaminated wings, and the time intervals required to achieve a dry wing surface were measured. Fokker F28 and Boeing 737 aircraft from Canadian Airlines International were provided for the trials.</p> <p>The time required to deice an entire wing of wet snow or frozen precipitation using the prototype ICE CAT infrared deicing system, as tested, needs to be reduced.</p>					
17. Key Words Aircraft deicing, mobile infrared system				18. Distribution Statement Limited number of copies available from the Transportation Development Centre	
19. Security Classification (of this publication) Unclassified		20. Security Classification (of this page) Unclassified		21. Declassification (date) —	22. No. of Pages xii, 30, app.
				23. Price Shipping/ Handling	



1. N° de la publication de Transports Canada TP 13489E		2. N° de l'étude 9326 (DC 161)		3. N° de catalogue du destinataire	
4. Titre et sous-titre Deicing with a Mobile Infrared System				5. Date de la publication Décembre 1998	
				6. N° de document de l'organisme exécutant	
7. Auteur(s) Elio Ruggi et Cassia Pole				8. N° de dossier - Transports Canada ZCD2450-B-14	
9. Nom et adresse de l'organisme exécutant APS Aviation Inc. 1100, boul. René-Lévesque Ouest Bureau 1340 Montréal, Québec H3B 4N4				10. N° de dossier - TPSGC XSD-7-01411	
				11. N° de contrat - TPSGC ou Transports Canada T8200-7-7557	
12. Nom et adresse de l'organisme parrain Centre de développement des transports (CDT) 800, boul. René-Lévesque Ouest Bureau 600 Montréal (Québec) H3B 1X9				13. Genre de publication et période visée Final	
				14. Agent de projet Barry B. Myers	
15. Remarques additionnelles (programmes de financement, titres de publications connexes, etc.) <p>Les rapports de recherche produits au nom de Transports Canada sur les essais réalisés au cours des hivers antérieurs peuvent être obtenus auprès du Centre de développement des transports (CDT). Le programme de la saison hivernale 1997-1998 a donné lieu à six rapports (dont celui-ci). On trouvera dans la préface l'objet de ces rapports. Les dépenses relatives à la fourniture et à l'exploitation du système de déglçage ICE CAT ont été assumées par Infra-Red Technologies Inc.</p>					
16. Résumé <p>Ce projet avait pour objectif principal d'évaluer l'efficacité d'un système de déglçage infrarouge mobile (en l'occurrence le système ICE CAT) à dégivrer des ailes d'avions recouvertes de différents types de contamination solide.</p> <p>Les essais du système ICE CAT ont eu lieu pendant deux nuits consécutives. Des précipitations naturelles de neige mouillée se sont produites la première nuit. Au cours de la deuxième nuit, les chercheurs ont simulé des précipitations de pluie verglaçante. L'essai consistait à placer le panneau chauffant du ICE CAT au-dessus des ailes contaminées et à mesurer le temps nécessaire à l'assèchement des surfaces. Un Fokker F28 et un Boeing 737 avaient été fournis par Lignes aériennes Canadien International pour la durée des essais.</p> <p>Les chercheurs ont conclu à la nécessité de réduire le temps nécessaire au dégivrage d'une aile complètement recouverte de neige mouillée ou de contamination solide à l'aide du prototype de système ICE CAT tel que mis à l'essai.</p>					
17. Mots clés Dégivrage d'aéronefs, système de déglçage infrarouge mobile			18. Diffusion Le Centre de développement des transports dispose d'un nombre limité d'exemplaires.		
19. Classification de sécurité (de cette publication) Non classifiée		20. Classification de sécurité (de cette page) Non classifiée		21. Déclassification (date) —	22. Nombre de pages xii, 30, ann.
					23. Prix Port et manutention

EXECUTIVE SUMMARY

Introduction

At the request of the Transportation Development Centre of Transport Canada, APS Aviation Inc. undertook this research program to further advance aircraft ground deicing/anti-icing technology and to enhance safety. The primary objective of the project was to explore the effectiveness of a mobile infrared deicing system for the removal of different types of frozen contamination from wing surfaces. This system offers the potential advantages of lower cost and reduced environmental risk.

Procedures and Data Processing

The ICE CAT, a system consisting of propane-fuelled flameless catalytic infrared emitters fitted into a large rectangular array, was provided by the developer, Infra-Red Technologies Inc. The array was supported by an articulating boom mounted on a truck bed.

The ICE CAT panel was positioned over a section of the aircraft wing, and the time intervals required to remove all traces of contamination from this and adjacent sections were measured. The time required to achieve a dry surface under the heater assembly set at several fixed heights above the wing and the time to clean an entire wing were also determined. Skin temperature was monitored and recorded throughout the trials by thermistor probes mounted at various points on the wing surface.

Conclusions and Results

The time required to deice an entire wing of wet snow or frozen precipitation for the prototype system, as tested, was unacceptably long. Deicing times would need to be reduced for the unit to be operationally viable.

Although the system's effectiveness in natural frost conditions was not examined, it is expected that the deicing time should be much shorter than that experienced with natural snow, and may be operationally acceptable.

SOMMAIRE

Introduction

APS Aviation Inc. a entrepris ce programme de recherche à la demande du Centre de développement des transports de Transports Canada dans le but de faire progresser les technologies de dégivrage/antigivrage au sol des aéronefs et d'accroître ainsi la sûreté du transport aérien. Ce projet avait pour objectif principal d'évaluer l'efficacité d'un système de déglacage infrarouge mobile à dégivrer des ailes d'avions recouvertes de différents types de contamination solide. Ce système, en l'occurrence le ICE CAT, pourrait être avantageux sur le plan des coûts et des répercussions sur l'environnement.

Protocole et traitement des données

Le système ICE CAT, composé d'émetteurs infrarouge à combustion sans flamme alimentés au propane, disposés à l'intérieur d'un grand panneau rectangulaire, a été fourni par son concepteur, Infra-Red Technologies Inc. Le panneau était fixé à l'extrémité d'un bras articulé monté sur un camion.

L'essai consistait à placer le panneau ICE CAT au-dessus d'une partie d'une aile contaminée et à mesurer le temps nécessaire pour éliminer toute trace de contamination sur cette partie et les parties adjacentes. Ont également été mesurés le temps pris par le ICE CAT, disposé à différentes hauteurs au-dessus de l'aile, pour assécher la surface de celle-ci, de même que le temps nécessaire pour nettoyer une aile complète. Pendant toute la durée des essais, la température du revêtement était mesurée et enregistrée par des sondes à thermistance disposées à divers endroits sur la surface de l'aile.

Conclusions

Le temps nécessaire pour déglacer une aile entièrement recouverte de neige mouillée ou de contamination solide à l'aide du prototype de ICE CAT tel que mis à l'essai s'est révélé trop long. Il y a lieu de réduire les temps de déglacage pour rendre le système viable en service.

Même si l'efficacité du système sous des précipitations givrantes naturelles n'a pu être vérifiée, on peut penser qu'il serait beaucoup moins long de déglacer une aile recouverte de givre naturel que de neige mouillée naturelle, et que ce temps de déglacage pourrait être acceptable.

CONTENTS

1.	INTRODUCTION	1
1.1	General.....	1
1.2	Deicing by Means of a Mobile Infrared System.....	1
2.	METHODOLOGY	3
2.1	Deicing by Means of a Mobile Infrared System.....	3
2.1.1	Trial Sites.....	3
2.1.2	Equipment.....	3
2.1.3	Description of Trial Procedures	4
2.1.4	Data Forms.....	6
2.1.5	Participants	7
3.	DESCRIPTION AND PROCESSING OF DATA	13
3.1	Deicing by Means of a Mobile Infrared System.....	13
3.1.1	Overview of Trials.....	13
3.1.2	Discussion of Test Variables.....	13
4.	DEMONSTRATION OF THE ICE CAT PROTOTYPE DEICING SYSTEM	15
4.1	ICE CAT “As-Tested” Description	15
4.2	Procedures and Data Forms	16
4.3	Effect on Wing Surface Temperature	17
4.3.1	Run 1: February 25, Port Wing, F28 (Figure 4.1).....	17
4.3.2	Run 2: February 25, Port Wing, F28	17
4.3.3	Run 3: February 25, Starboard Wing, F28 (Figure 4.2)	17
4.3.4	Run 1: February 26, Starboard Wing, B737 (Figure 4.3).....	18
5.	DISCUSSION AND OBSERVATION	23
5.1	Deicing by Means of a Mobile Infrared System.....	23
5.1.1	System Mobility.....	23
5.1.2	Effectiveness in Removing Contamination.....	23
5.1.3	Efficiency of Deicing Process.....	23
5.1.4	Wing Temperature Profile.....	24
6.	CONCLUSIONS.....	25
6.1	Deicing by Means of a Mobile Infrared System.....	25
7.	RECOMMENDATIONS.....	27
7.1	Deicing by Means of a Mobile Infrared System.....	27
	REFERENCES	29

LIST OF APPENDICES

- A Plan of Evaluation of ICE CAT Aircraft Deicing Systems

LIST OF FIGURES

Page

4.1 Wing Surface Temperature – February 25, Run 1.....	19
4.2 Wing Surface Temperature – February 25, Run 3.....	20
4.3 Wing Surface Temperature – February 26, Run 1.....	21

LIST OF TABLES

2.1 Plan for ICE CAT Aircraft Deicing Tests.....	5
3.1 Time to Deice and Evaporate Contamination.....	14

LIST OF PHOTOS

2.1 Underside of Heater Array.....	9
2.2 Heater Panel on Truck Boom.....	9
2.3 Heater Panel Positioned over the Wing	11

GLOSSARY

ADM	Aéroports de Montréal
AES	Atmospheric Environment Services
APS	APS Aviation Inc.
HOT	Holdover Time
OAT	Outside Air Temperature
READAC	Remote Environmental Automatic Data Acquisition Concept
RVSI	Robotic Vision System Inc.
TDC	Transportation Development Centre
UCAR	Union Carbide Corporation

This page intentionally left blank.

1. INTRODUCTION

1.1 General

At the request of the Transportation Development Centre (TDC), Transport Canada and APS undertook a research program to further advance aircraft ground deicing/anti-icing technology.

Aircraft ground deicing/anti-icing has been the subject of concentrated industry attention over the past decade due to a number of fatal aircraft accidents. Recent attention has been placed on alternative methods of deicing because environmental restrictions preclude the use of glycol.

This report contains the results of work conducted by APS Aviation in 1997/98 on the evaluation of a mobile infrared deicing system.

The contract work statement included:

Support for Review of Alternative Technologies

Provide support services for the evaluation of an infrared heating device to be demonstrated by Infra-Red Technologies Inc. as a low-cost and zero environmental impact alternative technology for aircraft deicing.

1.2 Deicing by Means of a Mobile Infrared System

The search for alternative approaches to aircraft deicing included examination of use of infrared radiation to melt ice or snow from aircraft surfaces, which offers the potential advantages of lower cost and reduced environmental risk. Fixed infrared deicing installations have been demonstrated previously. However, the ICE CAT is the first known application of this approach in the form of a mobile system.

As a mobile unit, the system could be used in two possible modes:

- At the gate; to remove overnight frost, ice, or snow contamination following termination of precipitation; and
- Off-gate deicing, or in conjunction with off-gate deicing; to deice the aircraft prior to application of anti-icing fluid.

The objectives of this study were to explore:

- The effectiveness of the ICE CAT system in removing different types of frozen contamination from a wing surface;

- The efficiency of the contamination removal in terms of time and quality;
and
- The effect of the infrared radiation on wing skin temperature.

Details of field tests are given in Section 4 of this report.

2. METHODOLOGY

This section of the report provides information about test facilities, equipment, procedures, and personnel involved in the ICE CAT demonstration.

2.1 Deicing by Means of a Mobile Infrared System

2.1.1 Trial Sites

An initial demonstration of the ICE CAT mobile deicing unit was conducted without collection of test data, during daylight hours, on standard SAE de/anti-icing fluid test plates mounted on a 10° inclined stand at the APS Dorval Airport test site on February 24, 1998.

Aircraft trials were performed at Gate 8, Montreal International Airport (Dorval), on the nights of February 24/25 and February 25/26, 1998.

2.1.2 Equipment

Canadian Airlines International provided overnighting aircraft for both sessions. A Fokker F28 was used for the February 24/25 trials, and a Boeing 737 was used for the February 25/26 trials.

The ICE CAT unit was provided by the system developer, Infra-Red Technologies Inc., of North Kansas City, Missouri. A detailed description of the unit and additional detail on the trials are provided in Appendix A. The system consisted of propane-fuelled flameless catalytic infrared emitters fitted into a large rectangular array. The infrared emitters could also be butane or natural gas fuelled. The array was supported by an articulating boom mounted on a truck bed that allows the array to be positioned over the wing surface. Photo 2.12 shows a close-up of the array and Photo 2.13 shows how it is mounted on the boom truck. Photo 2.14 shows the unit positioned over an aircraft wing for deicing.

Natural contamination (wet snow) occurred during the first night of trials. On the second night, simulated freezing rain was applied through use of a spray unit designed to deliver controlled rates and droplet size. This spray unit was assembled by APS to satisfy the requirement for artificial precipitation during the study *Contaminated Aircraft Take-Off Test for the 1997/98 Winter*. The unit is described in the TDC report, TP 13316E².

A large fan, mounted on top of a covered baggage cart, was used in conjunction with the heater panel to explore the use of blown air in removing melt water.

Thermistor probes were mounted on the aircraft wing, which, along with temperature loggers, provided an ongoing record of wing skin temperature.

An RVSI ice contamination camera was used to assist in confirming the final condition of the wing. Other equipment is listed in the ICE CAT trial procedure, and is provided in Appendix A.

2.1.3 Description of Trial Procedures

A matrix of trials was planned based on:

- The type of contamination present on the wing;
- The height of the heater array above the wing surface; and
- The simultaneous use of a large electric fan to control the flow of melt water.

Table 2.1 presents the planned series of trials.

The ICE CAT heater system included a wing surface temperature sensor with feedback to the heater units. The maximum permissible wing temperature was set at 60°C (165°F) to ensure no wing local overheating away from the sensor.

The functioning ICE CAT panel was positioned over the wing and the intervals required to remove all traces of contamination were measured. The times required to achieve a dry surface under the heater assembly set at several fixed heights above the wing were measured. The time to clean an entire wing was also determined.

The initial contamination thickness on the wing was recorded, and the precise area of contamination was mapped prior to trials.

Skin temperature was monitored and recorded throughout the trials by thermistor probes mounted at various points on the wing surface. Thermistor locations were varied from trial to trial to examine particular areas considered sensitive to elevated temperatures.

TABLE 2.1
PLAN FOR ICE CAT AIRCRAFT DEICING TESTS

RUN #	ICE CAT HEIGHT ABOVE WING	CONTAMINATION TYPE
1	1 m	NATURAL/SIMULATED FROST
2	2 m	
3	3 m	
4	1 m	NATURAL/SIMULATED SNOW
5	2 m	
6	3 m	
7	1 m	NATURAL/SIMULATED ICE
8	2 m	
9	3 m	
10	1 m*	NATURAL/SIMULATED ICE
11**	TBD	TBD

* Electric fan will be positioned near the leading edge.

** Run # 11 will measure the time required to deice an entire wing. Contamination type and ICE CAT height above the wing surface will be determined prior to testing.

2.1.4 Data Forms

Two data forms were used for the trials. The first was the *general form* (Appendix A, Figure 1), used to record specifics for each trial. The second was the *deicing form for aircraft wing* (Appendix A, Figure 2), used to map the area of contamination. These forms are included in the procedures contained in Appendix A.

2.1.5 Participants

Staff from Infra-Red Technologies Inc. operated the ICE CAT deicing system. Altec Industries provided the truck. APS Aviation staff were responsible for planning, co-ordinating, and conducting the trials. RVSI staff operated the ice detection camera.

At different stages of the test sessions, observers from Air Canada and TDC were in attendance.

This page intentionally left blank.

Photo 2.1
Underside of Heater Array



Photo 2.2
Heater Panel on Truck Boom



Photo 2.3
Heater Panel Positioned over the Wing



3. DESCRIPTION AND PROCESSING OF DATA

3.1 Deicing by Means of a Mobile Infrared System

3.1.1 Overview of Trials

Trials on aircraft were conducted during two overnight sessions as follows:

Date	Time	OAT (°C)	Type of Contamination
Feb 24/25, 1998	01:00 – 05:00	+ 1° C	Wet snow
Feb 25/26, 1998	01:00 – 05:00	+ 1 to -1° C	Artificial freezing mist

Three test runs were conducted with a Canadian Airlines International Fokker F28 aircraft on the February 24/25 session, and one test run was carried out on a Boeing 737-200 aircraft from the same airline on the February 25/26 session. All sessions were used to assess the speed and effectiveness of the ICE CAT unit in deicing surfaces, as well as to monitor wing surface temperatures. Runs #1 and #2 also examined the impact of varying the distance between heater array and the wing surface. Run #3 was used to evaluate the time required to clean an entire wing in natural snow conditions. Run #4 on February 26 examined the effectiveness of removing frozen contamination that resulted from the application of a simulated light mist on the upper wing surface. Table 3.1 provides the test details and trial results.

3.1.2 Discussion of Test Variables

Table 3.1 shows the times recorded to achieve a dry wing surface directly under the heater panel when positioned at different heights above the surface, and times to deice an entire wing. An elapsed time of 74 minutes was required to clean an entire wing contaminated with natural wet snow.

Temperature profiles for Runs #1 and #2 on the Fokker F28 and Run #4 on the Boeing 737 are included in Section 4.

TABLE 3.1
TIME TO DEICE AND EVAPORATE CONTAMINATION

	Type of Contamination	Wing Surface Area Deiced	Height from Wing Surface	Time to Deice (minutes)	⁽¹⁾ Time to Dry Surface (minutes)
Run 1 February 25, 1998 Port Wing F28	Natural snow (approx. 300 mil thick)	Mid-section of wing with of ICE CAT only	3.0 feet (0.9 metre)	10	20
Run 2 February 25, 1998 Port Wing F28	Natural snow (250 to 300 mil thick)	Outboard of wing section width of ICE CAT only	2.0 feet (0.6 metre)	7	9
Run 3 February 25, 1998 Starboard Wing F28	Natural snow/slush (300 to 350 mil thick)	Entire wing	3.28 feet (1.0 metre)	-	74
Run 4 February 26, 1998 Starboard Wing B737	Artificial freezing mist	Entire wing	3.28 feet (1.0 metre)	-	22

(1) In all cases, completely dry surface was not achieved.

4. DEMONSTRATION OF THE ICE CAT PROTOTYPE DEICING SYSTEM

Fixed location infrared deicing systems have been developed and are in service. ICE CAT is the first known mobile infrared deicing system and has the potential to be an alternative to standard glycol deicing, with the flexibility to operate at the gate or other locations where environmental restrictions could prohibit the use of glycol.

As previously stated, the objectives of the trials were to explore the effectiveness of the ICE CAT system in removing different types of frozen contamination from a wing surface in terms of time and quality, and to assess the potential for future use. These trials took the form of overnight demonstrations performed at Dorval Airport on February, 24/25 and February 25/26, 1998. Canadian Airlines International Ltd. (CAIL) provided the aircraft used for the trials. The first trial was performed on a Fokker F28 and the second on a B737. Thermistors were used to monitor the wing surface temperature at various locations.

4.1 ICE CAT "As-Tested" Description

The ICE CAT aircraft deicing system, as tested, used catalytic infrared heat emitters fuelled by propane. The emitters produce heat by flamelessly combusting gaseous fuel inside a platinum impregnated ceramic panel. The infrared heat emitters were fitted into a rectangular panel, lifted and positioned horizontally over the aircraft surfaces by an articulating boom truck. Panel manoeuvrability was possible from the truck, with a remote controller (umbilical) or with a wireless controller.

Back-up systems were included in the design. They included: locking devices for the hydraulic cylinders used to articulate the boom, engine start/stop by the remote controller, and a secondary power supply (12 V battery) to position the platform in case the engine should be non-functional or not permitted to function.

Each emitter had a surface area 0.6 m (24 inches) by 1.52 m (60 inches). Three emitters were put together to form a single heater unit; two units were mounted at the end of the articulating boom to form the panel assembly. The two outer emitters radiated a maximum heat flux of 7000 W (24 000 BTU) the central panel radiated a maximum heat flux of 17600 W (60 000 BTU). The fan out of the heat flux was 25° from horizontal. Total weight of the heating assembly was 440 kg (970 lbs.); the truck was rated for a 450 kg (1000 lbs.) load on the boom. Different sizes of heating assemblies are available, each size designed to fit a certain range of aircraft design.

The emitter fuel consumption and therefore the operating cost was very low: an average 6.8 kg (15 lbs.) of propane per hour for the test unit. During idling periods, emitter fuel consumption is one third of the standard operation consumption. The equipment could be operated by a single operator. Safety systems for the fuel feed included a high/low pressure sensor which, in the case of a line break, blockage, or other malfunction, would shut off the gas supply.

The heater array assembly can be adapted to most any boom-truck combination. Installation is fairly simple and does not restrict the manoeuvrability of the overall truck assembly, suggesting that it could also be successfully used for gate deicing.

The infrared heaters were controlled by a microprocessor based temperature controller that uses feedback from an infrared sensor, continuously monitoring the skin temperature of the aircraft. The control systems allow the operator to pre-set the desired maximum aircraft skin temperature and to maintain the desired temperature by continuously adjusting the amount of propane fuel being fed to the heaters. The temperature readings are viewed on a small video display, which had a second screen used to set the parameters of the display. A permanent record of the heating cycle could be stored digitally and a communication port was available to feed the values to a personal computer.

Alternatively, the distance between the heater array assembly and the aircraft wing surface can be easily adjusted to maintain a desired surface temperature.

4.2 Procedures and Data Forms

The ICE CAT heat emitter panel assembly was positioned over the wing and the start time recorded. Four trials were conducted, two trials on each of the two nights. Each trial continued until all traces of frozen wing contamination were gone. For the first two runs, conducted on a Canadian Airlines F28 aircraft, the time to deice the wing and the time to achieve a dry surface below the heater panel were both noted. For the second series of two runs, one run was conducted on a Canadian Airline Boeing 737 and one run was conducted on a Canadian Airlines F28. The time to deice the entire wing was noted for both trials.

The skin temperature was monitored throughout the trial to ensure that it never exceeded 82°C (180°F).

Thermistors were placed in various locations, as indicated in Section 4.3, to monitor the wing skin temperature in critical positions. During Run #1,

thermistor 7 was relocated from the spoiler to the high point of the outboard section deiced in Run #2. Thermistor 7 was the only thermistor used to monitor the skin temperature during Run #2. Also during Run #1, thermistors 4 and 5 were relocated to the spoiler.

During the first two trials, February 24/25th, there was heavy wet snow precipitation; however, during the second series of trials, February 25/26th, there was no precipitation and the wing surface was sprayed with artificial freezing contamination to simulate freezing drizzle and frost. The thickness of the contamination was measured prior to deicing.

4.3 Effect on Wing Surface Temperature

Wing temperature profiles are shown in Figures 3.1 to 3.3.

4.3.1 Run 1: February 25, Port Wing, F28 (Figure 4.1)

Thermistor 1	-	Drip point
Thermistor 2	-	Leading edge
Thermistor 3	-	Wing camber high point
Thermistor 4	-	Trailing edge/spoiler*
Thermistor 5	-	Under trailing edge/spoiler*
Thermistor 6	-	Inverted thermistor at high point
Thermistor 7	-	Spoiler/out of heated area*

* Thermistors 4 and 5 moved to spoiler, Thermistor 7 moved to outboard high point of heated area, in preparation for Run #2.

4.3.2 Run 2: February 25, Port Wing, F28

Thermistor 7	-	High point
--------------	---	------------

Thermistors 1-6 were not exposed to infrared heat during this portion of the test.

4.3.3 Run 3: February 25, Starboard Wing, F28 (Figure 4.2)

Thermistor 2	-	Leading edge
Thermistor 3	-	High point
Thermistor 4	-	Inverted thermistor of high point
Thermistor 5	-	Trailing edge
Thermistor 6	-	Under trailing edge

- Thermistor 7 - Spoiler, centre
- Thermistor 8 - Drip point (below and immediately behind the leading edge)

4.3.4 Run 1: February 26, Starboard Wing, B737 (Figure 4.3)

- Thermistor 1 - Leading edge
- Thermistor 2 - 6@ from leading edge inverted
- Thermistor 3 - 12@ from leading edge joint
- Thermistor 5 - On spoiler hinge
- Thermistor 7 - 2@ from trailing edge inverted

FIGURE 4.1
WING SURFACE TEMPERATURE
February 25, F28 Port Wing - Thermistors 1 to 7, Run 1

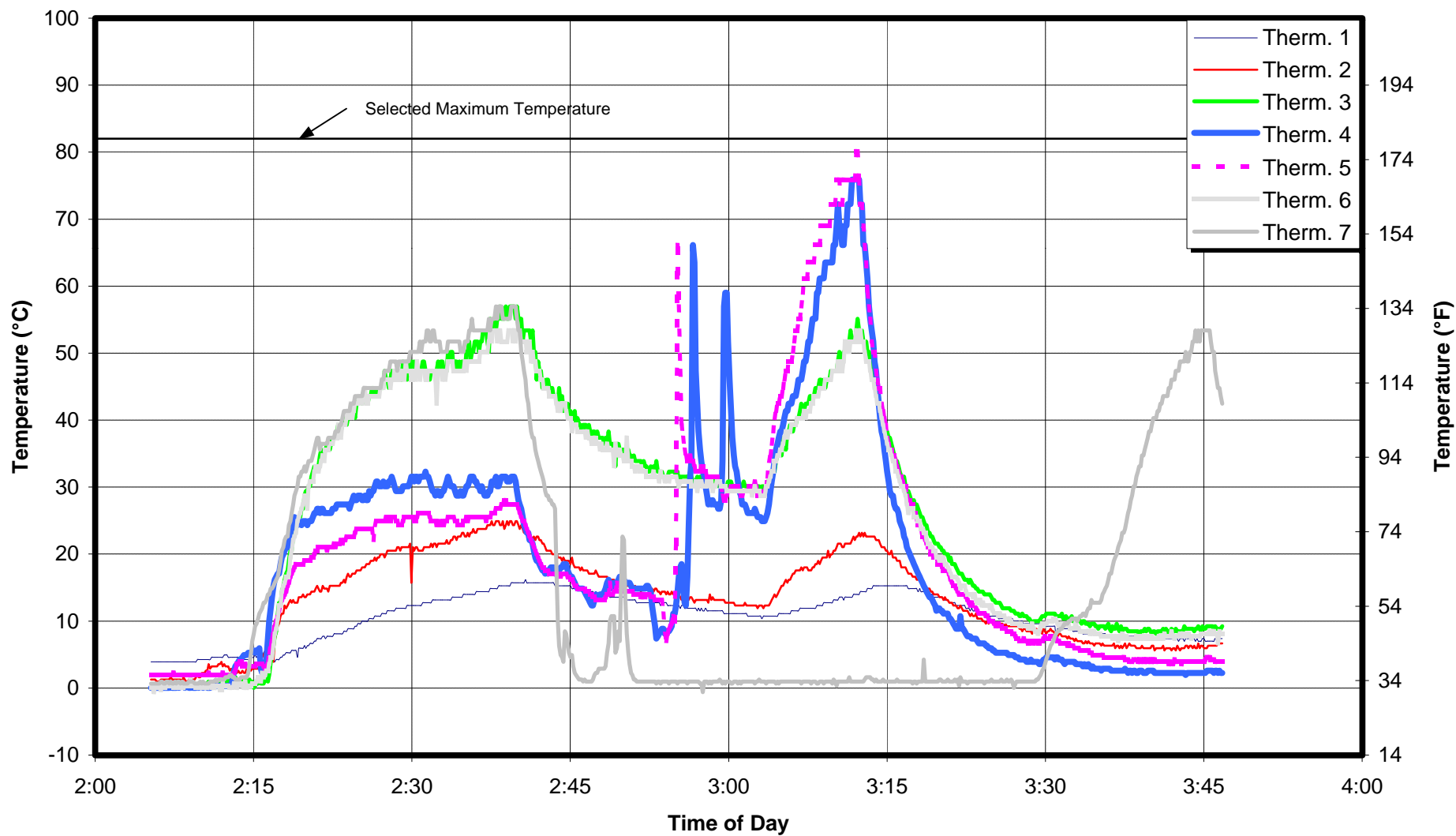

FIGURE 4.2

WING SURFACE TEMPERATURE

February 25, F28 Starboard Wing - Thermistors 1 to 8, Run 3

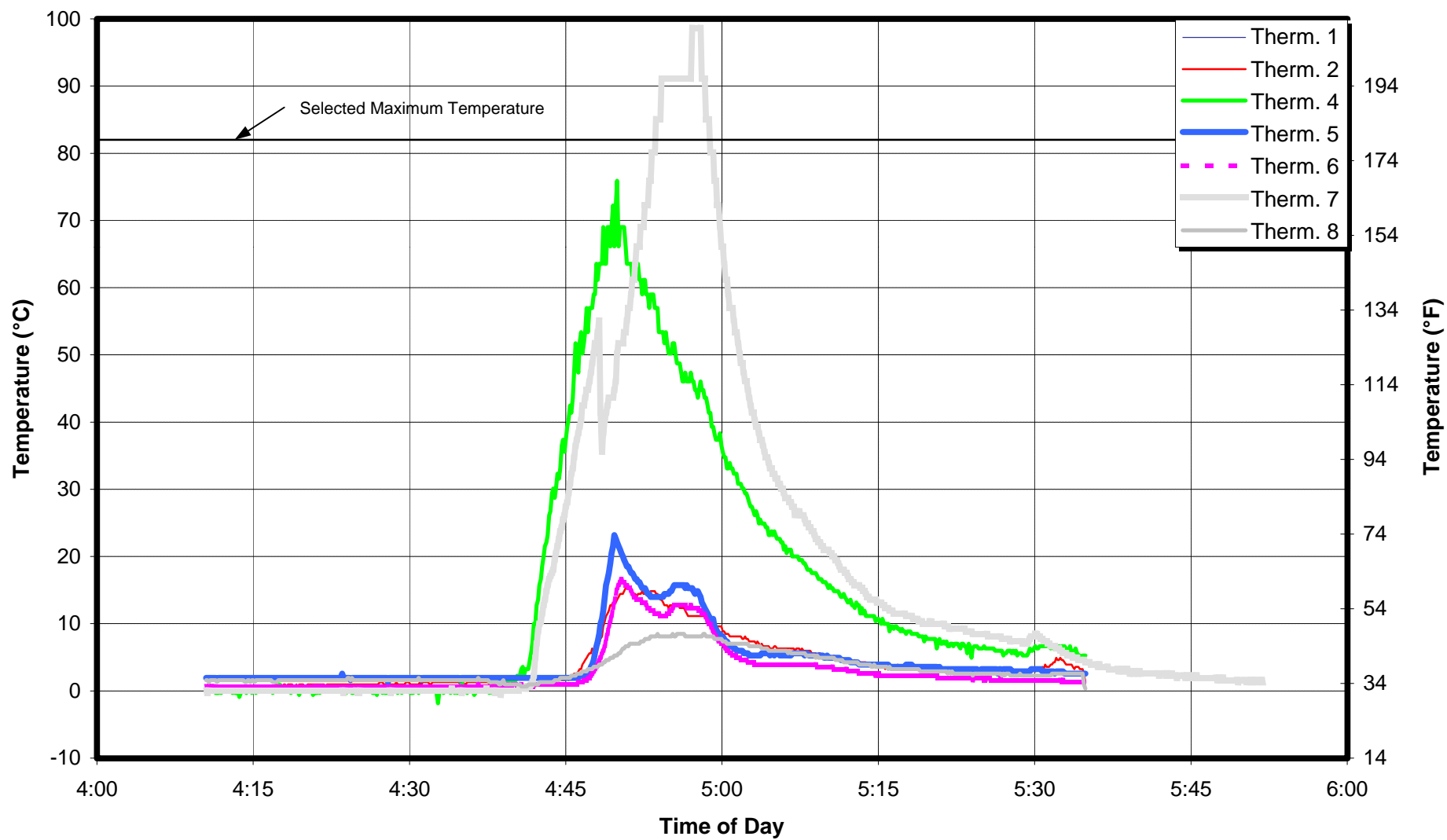
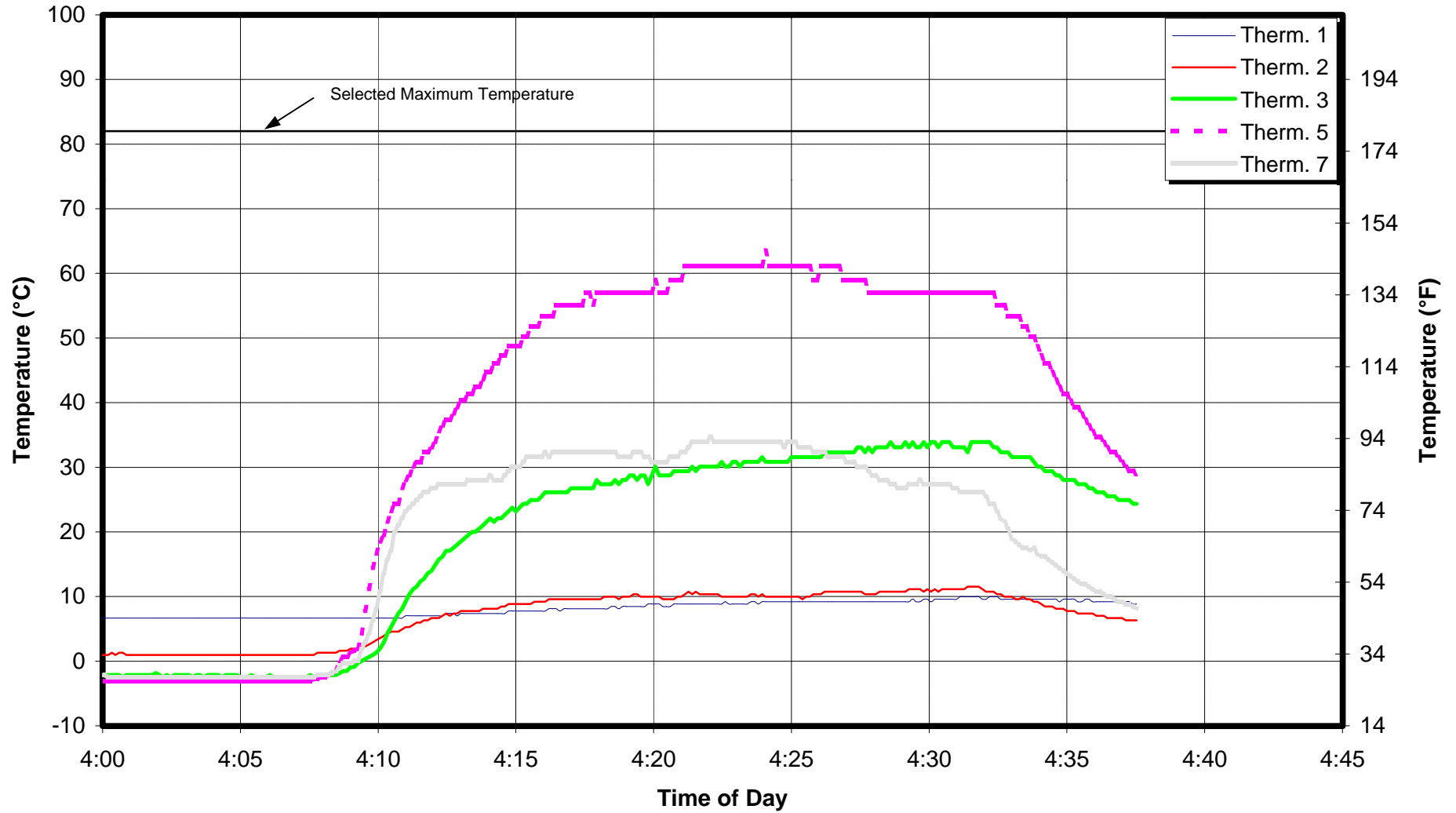

FIGURE 4.3
WING SURFACE TEMPERATURE
 February 26, B737 Port Wing - Thermistors 1 to 7, Run 1



This page intentionally left blank.

5. DISCUSSION AND OBSERVATION

5.1 Deicing by Means of a Mobile Infrared System

5.1.1 System Mobility

The mobile infrared system, as the name suggests, is a completely mobile system. An alternative high voltage power supply is required to prime start the system. A warm-up period is required for the system to obtain optimal working temperatures. After these preliminaries, the mobile system is limited only by the propane reserves in the on-board propane reservoir supply.

5.1.2 Effectiveness in Removing Contamination

The concept of deicing with a heater panel assembly smaller than the wing appears to be more suited to conditions when there is no active precipitation and anti-icing protection is not required. Although the temperature of the wing is elevated during the deicing process, it was observed that this temperature quickly returns to ambient with the attendant risk of re-contamination. Because the wing is deiced in sections, those sections already treated may become re-contaminated during the time required to deice the remainder of the wing. The demonstrated time required to deice an entire wing makes this aspect critical.

In conditions of no active precipitation, the wing surface for each section should be completely dry before moving on to the next. When the heater is removed, any existing melt water refreezes when the wing temperature cools to ambient. During the trials, the wing surface was not completely dried.

5.1.3 Efficiency of Deicing Process

The time required to deice an entire wing contaminated with wet snow or frozen precipitation with the test unit was unacceptably long for a live operation. Times would need to be reduced significantly in order for the unit to be operationally viable in any condition, either during or following termination of precipitation. It is reasonable to assume that this could be achieved in the future.

During the demonstrations, it was not possible to investigate the time required to remove natural frost. However, frost removal would be expected to be much faster, and may result in a time interval that is acceptable due to the thermal characteristics of a frost surface.

5.1.4 Wing Temperature Profile

Results of temperature measurements showed a variation in temperature across a pre-selected chord of the wing. Because the heater array is flat, the highest point of the wing (closest to the heater) would be expected to show the highest temperature. Generally, trial results show a temperature distribution that met this expectation. For example, trial results for Run 1, February 25, port wing (Section 4, Figure 3.1) show temperatures at different points along the chord:

- The leading edge drip point was 12 to 15°C;
- The skin temperature of the leading edge was approximately 23°C;
- The wing high point was measured to be 55°C; and
- The temperature at the trailing edge was measured to be 30°C and 25°C was measured under the trailing edge.

This variation in temperature would be expected to negatively affect deicing efficiency at the colder points (e.g. leading edge drip point).

With the fuel tank being located in the mid-section of the wing, where the thermistors were located, cold fuel may have acted as a heat sink and reduced the surface temperature at the high point. The fuel tanks were one half to three quarters full at the time of testing.

In all trials except for Run 2, the spoiler surface temperature readings met or exceeded temperature readings taken at the high point of the wing by up to 30°C and reached a maximum temperature of 80°C.

Modification of the distribution of heat emission would obviously be possible to increase temperatures in some areas and decrease deicing time.

6. CONCLUSIONS

6.1 Deicing by Means of a Mobile Infrared System

The heater array assembly can be adapted to almost any boom-truck combination. Installation was fairly simple and does not restrict the manoeuvrability of the overall truck assembly, suggesting that it could also be successfully used for gate deicing.

The system has the advantage of a very low operating cost, with an average consumption of 6.8 kg/hr (15 lb./hr) and the ability to be operated by only one operator.

Wing surface temperatures can be monitored by an infrared system that is linked to, and controls the infrared heaters. Alternatively, the distance between the heater array assembly and the aircraft wing surface can be easily adjusted to maintain a desired surface temperature.

The temperature profiles along the pre-selected wing chord raise a concern with the design of the ICE CAT system as tested. The wide variation in wing surface temperature observed due to uneven heat distribution and the disparity in geometry between the shape of the heater panel and the shape of the wing surface should be considered. For the demonstrations, a maximum wing surface temperature was established at 82°C, typical of maximum application temperatures for deicing fluids. Points on the wing more distant from the heater panel, such as the leading and trailing edges, will never reach the maximum temperature obtained by more sensitive areas, such as the spoiler panel, possibly making a completely dry surface unachievable.

The amount of fuel in wing tanks may affect the deicing results, particularly for wet-wing aircraft. Other factors that will affect the temperature gradient of the wing surface are the variations in geometry of the wing structure and the difference in the reflective, absorptive, and conductive properties of the wing surface. Different surfaces reflect, absorb, conduct, and transmit radiation differently.

The time required to deice an entire wing of wet snow or frozen precipitation for the prototype unit, as demonstrated, was unacceptably long. Deicing times would need to be reduced for the unit to be operationally viable.

Although the system's effectiveness in natural frost conditions was not examined, the deicing time should be much shorter than that experienced with natural snow, and may be operationally acceptable.

There may be an opportunity to develop and market the system as a solution

6. CONCLUSIONS

for frost removal. Incorporation of blowing fans could be considered to assist in removing melt water from the surface to prevent it from running into wing cavities. Defrosting constitutes a relatively large part of winter deicing operations, and when viewed on the basis of the amount of contamination being removed, fluid deicing is a high-cost operation.

7. RECOMMENDATIONS

7.1 Deicing by Means of a Mobile Infrared System

The ICE CAT deicing system is a potential alternative to standard glycol deicing technology and could be used for removal of overnight frost accumulation. Such deicing could be completed at the gate while the aircraft is being prepared and loaded for takeoff. Although the system could be used to deice other types of frozen contamination following termination of precipitation, demonstrated deicing times are much too long to be operationally acceptable.

Important issues need to be addressed if the ICE CAT is to serve as a viable alternative to standard glycol deicing technology. The most apparent of these is the lengthy time required to deice an entire wing. Times would need to be reduced for the unit to be operationally viable.

This page intentionally left blank.

REFERENCES

1. D'Avirro, J., Chaput, M., Hanna, M., Peters, A., *Aircraft Ground De/Anti-icing Fluid Holdover Time Field Testing Program for the 1997/98 Winter*, APS Aviation Inc., Montreal, December 1998, Transportation Development Centre, TP 13318E, 200
2. Dawson, P., Hanna, M., Chaput, M., *Contaminated Aircraft Takeoff Test 1997/98 Winter*, APS Aviation Inc., Montreal, December 1998, Transportation Development Centre, TP 13316E, 52
3. D'Avirro, J., Chaput, M., Dawson, P., Hanna, M., Fleming, S., *Aircraft Full-Scale Test Program for the 1996/97 Winter*, APS Aviation Inc., Montreal, December 1997, Transportation Development Centre, TP 13130E, 180
4. Dawson, P., D'Avirro, J., *Evaluation of Fluid Thickness to Locate Representative Surfaces*, APS Aviation Inc., Montreal, October 1996, Transportation Development Centre, TP 12900E, 109

This page intentionally left blank.

APPENDIX A

PLAN OF EVALUATION OF ICE CAT AIRCRAFT DEICING SYSTEMS

CM1380.001

**EXPERIMENTAL PROGRAM
EVALUATION OF ICE CAT AIRCRAFT DEICING SYSTEMS**

Winter 1997/98



February 20, 1998
Version 2.0

EXPERIMENTAL PROGRAM
EVALUATION OF ICE CAT AIRCRAFT DEICING SYSTEMS
Winter 1997/98

1. OBJECTIVE

The objective of this series of tests is to evaluate the performance of ICE CAT aircraft deicing systems on contaminated aircraft wing surfaces.

2. PLAN

ICE CAT aircraft deicing system tests will be conducted at Dorval airport in Montreal from February 23 to February 27, 1998. Aircraft deicing trials will be performed following periods of natural precipitation or frost on Boeing 737 aircraft. If natural precipitation does not occur during this period, the aircraft contamination process will be reproduced by artificial means.

A matrix of tests is anticipated based on:

- C The use of an electric fan to prevent the flow of liquid contaminants to the leading edge of the aircraft;
- C The type of contamination present on the wing at the time of testing (natural or simulated); and
- C The height of the ICE CAT heater array above the wing surface.

The test plan for the conduct of ICE CAT aircraft deicing tests is shown in Attachment I.

Natural frost deicing trials will be conducted if frost is present on the aircraft when it is towed to the pad. For snow and ice contamination tests, a known quantity of snow and water will be applied to the wing if no natural precipitation occurs. In all cases, the ICE CAT aircraft deicing system will be used to deice the contamination present on the aircraft wing.

3. EQUIPMENT

The equipment needed for the conduct of ICE CAT tests is shown in Attachment II.

4. PERSONNEL

A team of seven APS personnel is required for the conduct of these tests. A description of the responsibilities and duties of each member of the test team is included in Attachment III. Furthermore, ground support personnel from the airlines will be available to position the aircraft and facilitate the inspection of the critical aircraft surfaces. The ICE CAT aircraft deicing system will be operated by ICE CAT personnel.

5. PROCEDURE

The test procedure for the conduct of ICE CAT aircraft deicing tests is included in Attachment IV.

6. DATA FORMS

Data forms to be used in ICE CAT deicing trials are listed below:

- ☐ Figure 1 General Form (Every Test); and
- ☐ Figure 2 De/anti-icing Form for Aircraft Wing (B-737).

It is extremely important that the area of the wing contaminated by natural or simulated precipitation be accurately mapped by the wing observer on Figure 2 prior to the deicing of the wing. The times prior to deicing and immediately following deicing should also be accurately recorded on Figures 1 and 2.

FIGURE 1
GENERAL FORM (EVERY TEST)
(TO BE FILLED IN BY PLATE/WING COORDINATOR)

DATE: _____

WING: PORT (A) STARBOARD (B)

RUN #: _____

DIRECTION OF AIRCRAFT: _____ DEGREES

DRAW DIRECTION OF WIND WRT WING:



<u>DEICING</u>	
Actual Start Time: _____ hh:mm:ss	Actual End Time: _____ hh:mm:ss
Distance from wing: _____ meter	
<u>CONTAMINATION DATA</u>	
Type of Contamination: _____	Quantity of simulated snow: _____ g
Natural/Artificial: _____	Quantity of simulated ice/frost: _____ Liters (Water)

COMMENTS: _____

MEASUREMENTS BY: _____

HAND WRITTEN BY: _____

FIGURE 2
DE-ICING FORM FOR AIRCRAFT WING

REMEMBER TO SYNCHRONIZE TIME

VERSION 4.0

Winter 96/97

DATE: _____	RUN NUMBER: _____	START TIME: _____	END TIME: _____
-------------	-------------------	-------------------	-----------------

HANDWRITTEN BY: _____

COMMENTS: _____

ASSISTED BY: _____

WING MAPPING

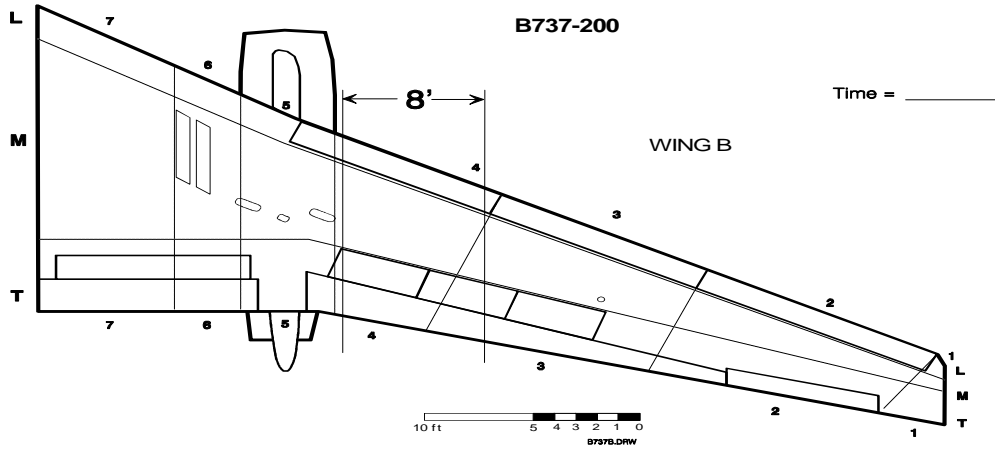

DE-ICING

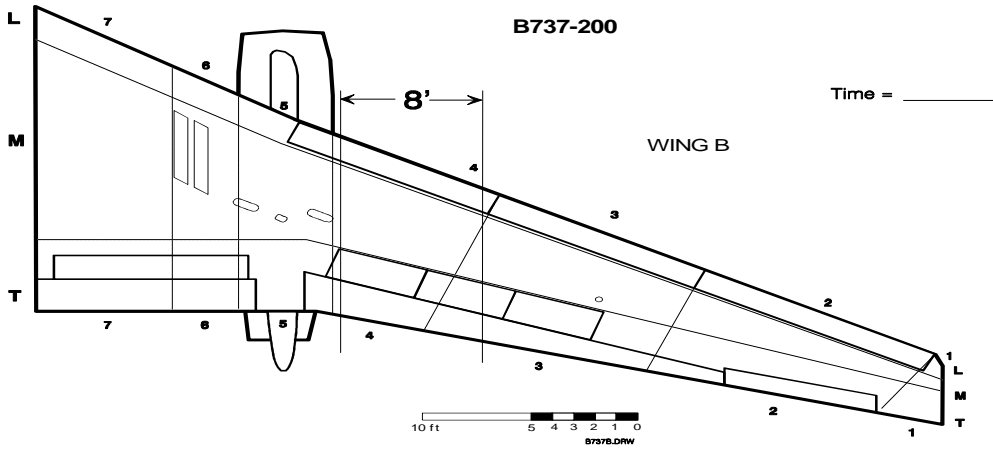

DE-ICING

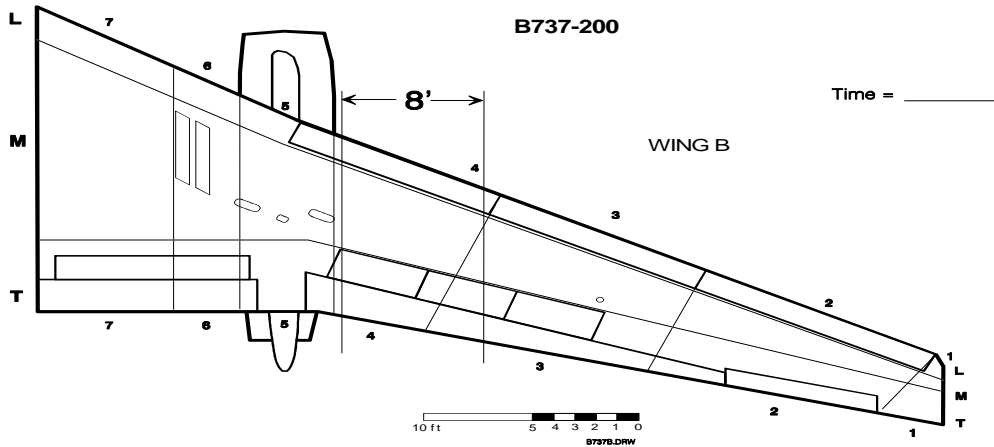

ATTACHMENT I
PLAN FOR ICE CAT AIRCRAFT DEICING TESTS⁽¹⁾

RUN #	ICE CAT HEIGHT ABOVE WING	CONTAMINATION TYPE
1	1 m	NATURAL/SIMULATED FROST
2	2 m	
3	3 m	
4	1 m	NATURAL/SIMULATED SNOW
5	2 m	
6	3 m	
7	1 m	NATURAL/SIMULATED ICE
8	2 m	
9	3 m	
10	1 m*	NATURAL/SIMULATED ICE
11**	TBD	TBD

⁽¹⁾ Standard flat plates will be utilized together with an aircraft.

* Electric fan will be positioned near the leading edge.

** Run # 11 will measure the time required to deice an entire wing. Contamination type and ICE CAT height above the wing surface will be determined prior to testing.

This page intentionally left blank.

ATTACHMENT II

THERMISTOR LOCATIONS FOR ICE CAT TESTS

Thermistor Locations: Thermistors should be located 4 feet outboard of the engine, starting on the leading edge nose and moving back to the trailing edge. All thermistors should run parallel to the engine.

Wing Contamination Area: The wing contamination area stretches 8 feet outboard from the engine and includes the leading and trailing edges.

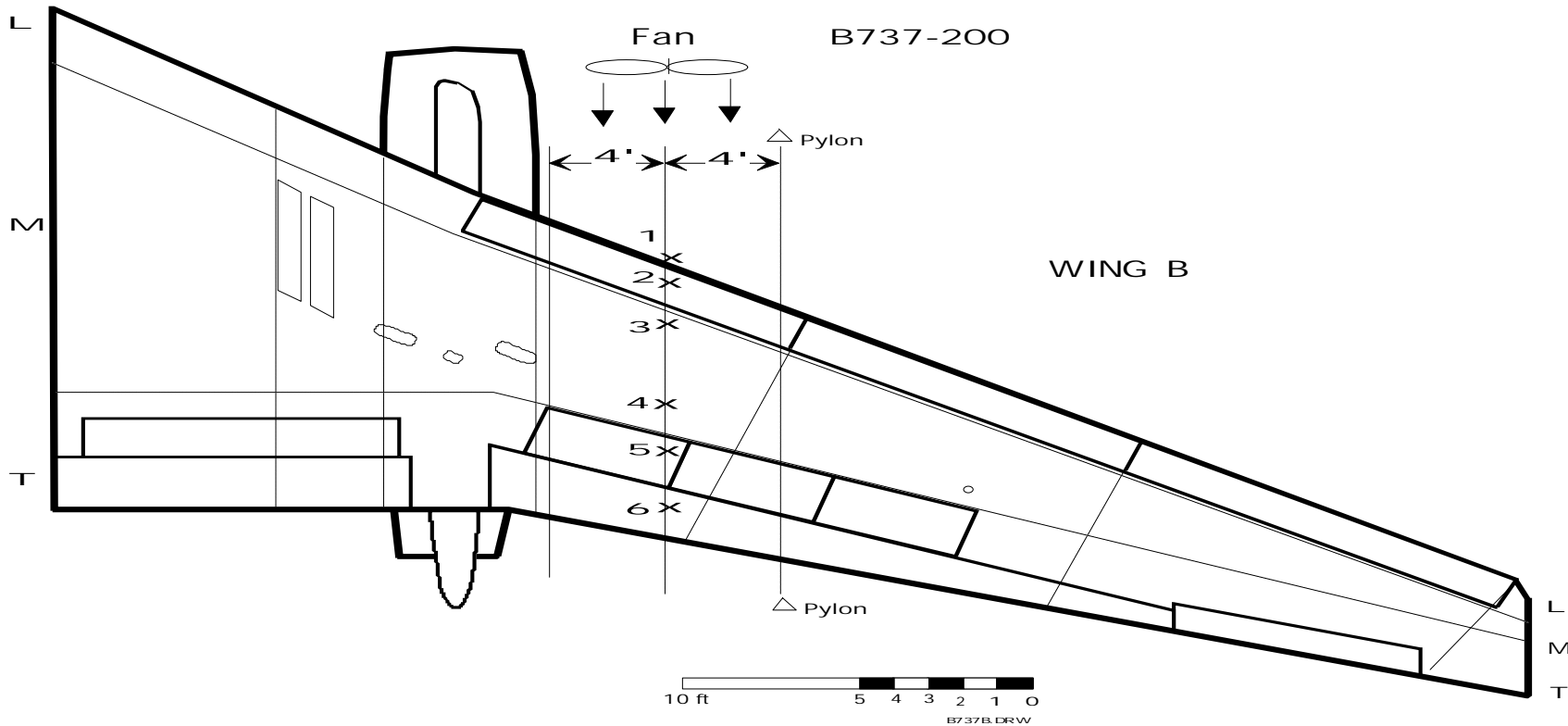

- | | | |
|------------------------------|---------------------------------|------------------------------|
| Thermistor Locations: | 1 - On Leading Edge Nose | 4 - 12" above spoiler panels |
| | 2 - 6" from Leading Edge Nose | 5 - 24" from Trailing Edge |
| | 3 - 12" from Leading Edge joint | 6 - 6" from Trailing Edge |

This page intentionally left blank.

ATTACHMENT III
ICE CAT DEICING TRIALS
TEST EQUIPMENT CHECKLIST

TASK
Logistics for Every Test
Rent Van / Rent cube / Rent lighting
Call Personnel
Advise Airlines (Personnel, A/C Orientation, Equip)
Monitor Forecast
Call potential participants
Test Equipment
SPAR Camera Kit
RVSI Camera - charged 12 V battery
Ice Cat Deicing Vehicle
V1, V2, P1 kits
T2, T4 kit
T6 kit
Marking kit
Airport general box
1 broom
Thermistor Kit
Data Forms (general)
Aircraft Wing Forms
Compass X 1
Hand-held temperature probes X 2
2 big squeegees
Heat dish
Temperature probe extensions X 2
550V, 15KW generator and bare extension
2 tripod lights
Extension cords
Pylons X 3
FM headset radios
Extended thickness gauges kit
Wind vane
All rolling stairs
1 Table
Tall step ladders X 2
Electric fan
Metal shovels X 2
Plastic shovels X 2
2 chairs
Hand-held sprayer and backpack sprayer
Water supply and hand pump
Block passes
Laptop computer
Snow supply-4 large bins
Compressed air sprayer kit
Test procedure x 6
Small generator
Filing box for data sheets

This page intentionally left blank.

ATTACHMENT IV
RESPONSIBILITIES/DUTIES OF TEST PERSONNEL

Photographer/Video (JM)

- C Ensure equipment is serviceable;
- C Video/photo setup, probe installation on wing, ICE CAT preparation;
- C Video/photo wing condition prior to testing;
- C Video/photo artificial contamination process;
- C Video/photo ICE CAT operation and evolution of wing condition;
- C Video/photo final wing condition following ICE CAT operation;
- C Knowledge of test procedures;
- C Assist in deployment of lighting; and
- C Ensure that video tapes/films are given to the test coordinator after each test.

Spar Operator/RVSI Operator (ER)

- C Located on rolling stairs during tests;
- C Assist in test set-up;
- C Position rolling stairs to allow viewing of the entire wing without need to reposition;
- C Monitor test surfaces with Spar/RVSI camera, ensuring ongoing operation and image capture of all tests; and
- C Retrieve tape from camera following test.

Thermistor Operator (MH)

- C Assist in test set-up;
- C Ensure thermistor equipment is operational prior to testing;
- C Install thermistor equipment on wing during ICE CAT warm-up period;
- C Monitor system operation throughout test;
- C Save information following each test and ensure it is given to the test coordinator at the end of the test session; and
- C Record thickness measurements on aircraft wing prior to ICE CAT deicing.

Equipment Technician/Wing Contaminator (NB)

- C Assist in test set-up;
- C Ensure that propane truck is available for ICE CAT;
- C Coordinate equipment movements to/from test site;
- C Ensure equipment is operational;
- C Set up site, cones, stairs, truck position, lighting equipment;
- C If artificial wing contamination is required, apply snow or water onto wing surface to simulate natural precipitation;
- C Record the amount of water/snow applied to wing; and
- C Ensure that data is recorded on the appropriate data sheet and given to the test coordinator at the end of the test session.

Wing Observer (MC)

- C Assist in test set-up;
- C Map the wing surface prior to testing;
- C Record deicing times;
- C Observe and draw any ice formation on wings following the operation of ICE CAT. Special attention should be paid to water drips in the flight controls and tracks, icicle formation under the leading and trailing edges; and
- C Ensure that the wing data forms are filled out properly and given to the test coordinator at the end of the test session.

Overall Coordinator (JD/PD)

- C Team coordinator;
- C Responsible for area and people;
- C Monitor operation of thermistors during tests;
- C Knowledge of test procedures;
- C Coordinate actions of APS team and, as required, airline personnel;
- C Call personnel to conduct tests;
- C Ensure that there are no objects on the ground at the end of the test session;
- C Ensure that the site is safe, functional and operational at all times;
- C Supervise site personnel during the conduct of tests;
- C Review data forms upon completion of tests for completeness and correctness;
- C Ensure that aircraft is positioned properly;
- C Monitor weather forecasts prior to and during the test period;
- C Ensure that all equipment is available;
- C Ensure proper documentation of tapes, diskettes, cassettes;
- C Ensure aircraft is not damaged; and
- C Complete general data form at beginning of the test session.

ATTACHMENT V TEST PROCEDURE FOR ICE CAT AIRCRAFT DEICING TESTS

1. PRE-TEST SET-UP

- C Insure that ICE CAT personnel are familiar with test procedures;
- C Arrange for aircraft to be towed to the test area and placed in a favourable aircraft orientation (nose into the wind is suggested);
- C Position the ICE CAT, cube van, and mini-van near the test area;
- C Set up power cords and generator;
- C Inform the ICE CAT operator of the test plan and commence ICE CAT pre-heating;
- C Place pylons below the wings to identify test sections;
- C Position stairs and lights;
- C Ensure that RVSI/Spar cameras are positioned for testing;
- C Videotape test area set-up and ICE CAT warm-up period;
- C Install thermistors on wing at the locations shown in Attachment II. Ensure all probes are functional;
- C Position an electric fan near the aircraft leading edge (if applicable);
- C Establish communication between team members and coordinator;
- C Synchronize all timepieces including video cameras and still camera;
- C Distribute FM headsets and ensure they are functional; and
- C Prepare data forms in advance for all tests.

2. EXECUTION OF ICE CAT TESTS

- c Measure (weigh) the quantity of contaminant (water, snow) to be applied to the wing surface;
- C If natural frost or precipitation does not occur, contaminate the wing surface (snow will be manually applied on the wing, water will be sprayed using a compressed air sprayer). Ensure that wing conditions prior to and following the contamination period are recorded with RVSI/Spar cameras and video camera as well as drawn on the wing data forms;
- C Measure the thickness of the wing contaminant applied prior to deicing;
- C Observe and record the condition of the wing following the contamination period prior to deicing;
- C Position the ICE CAT over the wing. Tests will be conducted with the ICE CAT heater array positioned at three different heights above the wing (1 m, 2 m and 3 m). Record the start time of the deicing process;
- C Ensure photo/video capture of events throughout the test period;
- C Ensure that the maximum wing surface temperature of 180°F is not surpassed. Adjust the height of the ICE CAT unit over the wing to keep the wing temperature as close to 150°F as possible;

- C Test continues until all trace of wing surface contamination is gone. Remove ICE CAT from the wing surface and note the end time;
- C Observe and record any remaining traces of contamination in the flight controls and under the leading and trailing edge surfaces. Note any formation of ice or icicles on these particular surfaces. Ensure that no ice is present in the flap tracks;
- C Restart test time, and use ICE CAT to remove any remaining contamination;
- C Stop the test time and re-inspect the wing; and
- C Repeat this procedure for each condition.