

# **CANADIAN PLUMBING CODE**

**1970**

**BASED ON THE NATIONAL BUILDING  
CODE OF CANADA 1970**

**(First printing — 1971)**

**Issued by the  
Associate Committee on the National Building Code  
National Research Council of Canada  
Ottawa**

**Price \$1.50**

**NRCC 11559**

**THE ASSOCIATE COMMITTEE ON THE  
NATIONAL BUILDING CODE OF CANADA**

<b>C. D. Carruthers</b> (Chairman)	<b>A. Matthews</b>
<b>H. B. Dickens</b> (Deputy Chairman)	<b>F. X. Perreault</b>
<b>J. D. Beaty</b>	<b>K. R. Rybka</b>
<b>R. A. Bird</b>	<b>H. R. Stenson</b>
<b>J. G. Burchill</b>	<b>R. A. W. Switzer</b>
<b>S. D. C. Chutter</b>	<b>J. M. Verreault</b>
<b>W. G. Connelly</b>	<b>D. H. Waller</b>
<b>I. Coop</b>	<b>V. S. Baker</b> (ex officio)
<b>R. F. DeGrace</b>	<b>P. Dobush</b> (ex officio)
<b>R. M. Dillon</b>	<b>C. G. E. Downing</b> (ex officio)
<b>S. A. Gitterman</b>	<b>T. R. Durley</b> (ex officio)
<b>W. B. Guihan</b>	<b>H. T. Jones</b> (ex officio)
<b>R. V. Hebert</b>	<b>J. Longworth</b> (ex officio)
<b>D. A. Matheson</b>	<b>A. T. Mann</b> (ex officio)
<b>R. S. Ferguson</b> (Research Advisor)	<b>J. M. Robertson</b> (Secretary)

**REVIEW COMMITTEE ON  
PLUMBING SERVICES**

<b>V. S. Baker</b> (Chairman)	<b>P. E. Kent</b>
<b>M. Bolduc</b>	<b>T. W. Lane</b>
<b>W. Delamare</b>	<b>A. W. McIntyre</b>
<b>T. Dixon</b>	<b>T. Fellow</b>
<b>L. A. Kay</b>	
<b>A. D. Kent</b> (Research Advisor)	<b>J. M. Robertson</b> (Secretary)

# **CANADIAN PLUMBING CODE**

**1970**

**BASED ON THE NATIONAL BUILDING  
CODE OF CANADA 1970**

**(First printing — 1971)**

**Issued by the  
Associate Committee on the National Building Code  
National Research Council of Canada  
Ottawa**

**© National Research Council of Canada 1970  
World rights reserved**

## PREFACE

The Canadian Plumbing Code is published by the National Research Council of Canada, through the Associate Committee on the National Building Code. Preparation of this Code as a separate publication from the National Building Code is a recognition of the prominence of the subject matter, of the fact that plumbing regulations are commonly administered separately from other building regulations, and of the plumbing industry's need for a document that interprets the intent of the Code requirements.

The purpose of this Code is to interpret, not to alter, the plumbing requirements of the National Building Code, and to combine the requirements and interpretive material into a single, complete, reference volume.

The requirements of this Code are identical to those of Part 7, Plumbing Services, of the National Building Code of Canada (NBC) 1970. The same numbering system has been retained for the excerpts reprinted herein and this Code has been arranged to provide maximum convenience in its use.

The explanatory material included in the Code was prepared for the Associate Committee with the assistance of the Atlantic Industrial Research Institute. The work was carried out by Mr. D. A. Tupper, under the direction of Professor D. H. Waller. Special thanks are due to Messrs. T. Dixon and V. S. Baker, who reviewed the Code as representatives of the Revision Committee on Plumbing Services, and to the members of the CSA Plumbing Advisory Council, who provided useful comments on the final drafts.

Enquiries regarding this document should be directed to:

The Secretary,  
Associate Committee on the  
National Building Code,  
National Research Council of Canada,  
Ottawa, Ontario,  
Canada. K1A 0R6.

# **TABLE OF CONTENTS**

## **AND**

### **LIST OF ILLUSTRATIONS**

	Page
A Guide to the Use of the Code . . . . .	ix
<b>CHAPTER I — DEFINITIONS AND ABBREVIATIONS—</b> From Part 2 of the NBC	
Section 2.1 Definitions . . . . .	1
Section 2.2 Abbreviations . . . . .	16
<b>CHAPTER II— PLUMBING SERVICES—</b> Part 7 of the NBC	
Section 7.1 General Requirements . . . . .	17
Section 7.2 Materials . . . . .	19
Section 7.3 Piping . . . . .	34
Section 7.4 Drainage Systems . . . . .	43
Section 7.5 Venting System . . . . .	74
Section 7.6 Potable Water System . . . . .	94
Section 7.7 Non-potable Water System . . . . .	101
<b>APPENDIXES</b>	
Appendix A Administration—Part 1 of the NBC . . . . .	103
Appendix B Use and Occupancy—Excerpts from Part 3 of the NBC . . . . .	111
Appendix C Materials—Excerpts from Part 5 of the NBC . . . . .	119
Appendix D Housing and Small Buildings—Excerpts from Part 9 of the NBC . . . . .	123
Appendix E Table of Rainfall Intensities—Excerpts from Supplement No. 1 to the NBC Climatic Information for Building Design in Canada . . . . .	127
<b>INDEX</b> . . . . .	133

## LIST OF ILLUSTRATIONS

Figure		Page
1	Back-siphonage.....	2
2	Typical back-siphonage preventer.....	2
3	Typical backflow preventers.....	3
4	Branch vent.....	4
5	Circuit or loop vent connection.....	4
6	Effective opening.....	6
7	Fixture drains and fixture outlet pipes.....	6
8	Headers.....	7
9	Main vents.....	8
10	Nominally horizontal and vertical pipes.....	9
11	Offsets.....	10
12	Plumbing system.....	11
13	First storey.....	12
14	Parts of a trap.....	13
15	Drainage and venting system.....	14
16	Drainage system (Isometric view).....	15
17	Shower drainage.....	22
18	Trap seal and trap connections.....	23
19	Prohibited traps.....	23
20	T fittings in drainage systems.....	24
21	Sanitary TY fittings in drainage systems.....	25
22	Double Y fittings.....	26
23	Summary of pipe applications.....	31
24	Cleanout ferrules.....	33
25	Service piping.....	38
26	Support for underground piping.....	40
27	Backfilling of pipe trench.....	41
28	Protection of underground non-metallic pipes.....	41
29	Fixture connections to vent pipes.....	45
30	Connections to horizontal offsets in soil-or-waste stacks.....	46
31	Indirect connections.....	47
32	Air break.....	48
33	Trapping of compartment sink.....	49
34	Location of trap or interceptor.....	50

Figure	Page
35	Maintaining trap seals..... 52
36	Traps for storm drainage system..... 53
37	Subsoil drainage connections..... 53
38	Arrangement of piping at sump..... 55
39	Protection from backflow caused by surcharge..... 55
40	Cleanouts for building drains..... 56
41	Spacing of cleanouts..... 57
42	Cleanouts for food receptacle drip pipe..... 58
43	Types of cleanouts..... 58
44	Minimum slopes of drainage pipes..... 59
45	Maximum loads on sanitary sewers having low slopes..... 63
46	Maximum loads on storm and combined building sewers having low slopes.. 64
47	Minimum sizes of drainage pipes..... 66
48	Sizing of soil-or-waste pipes serving as vents..... 67
49	Relationship between fixture units and demand, gpm..... 68
50	Storm drainage areas (Example I)..... 70
51	Storm drainage components (Example I) (elevation view)..... 71
52	Storm drainage pipe sizes (Example I)..... 71
53	Building drainage system (Example II)..... 72
54	Trapping indirectly connected fixtures..... 74
55	Basement floor drains..... 75
56	Vent connections..... 76
57	Dual venting..... 77
58	Wet venting..... 78
59	Stack venting..... 79
60	Circuit and loop venting..... 80
61	Relief venting..... 81
62	Yoke vent connections..... 82
63	Yoke vents for a 12-storey building..... 83
64	Minimum size of stack vents..... 83
65	Venting of oil interceptor..... 84
66	Vent pipe connections..... 85
67	Vent pipe terminals..... 86
68	Location of vent pipe terminal..... 87
69	Developed length of continuous vent..... 88

Figure		Page
70	Developed length of branch vent.....	88
71	Developed length of header.....	89
72	Sizing stack vent and vent stack terminal section.....	90
73	Sizing of building venting system.....	92
74	Table of vent pipe sizes.....	93
75	Height of air gaps.....	97
76	Installation of air gaps and back-siphonage preventers.....	98



## A GUIDE TO THE USE OF THE CODE

This Code consists of excerpts from the National Building Code of Canada, 1970, and explanatory material. In order to differentiate between the requirements of the NBC and the explanatory material, the Code material has been printed in bold face type, for example:

Code requirement	<b>(2) Where a proportional weir roof drain is installed . . .</b>
Explanatory note	A proportional weir holds back the peak flow resulting from a rainfall . . .

Each excerpt from the NBC 1970 includes the applicable reference number as it appears in the NBC. These are used in the explanatory notes for reference purposes. The decimal numbering system used in the NBC is divided as follows:

<b>7.</b>	<b>Part</b>
<b>7.5</b>	<b>Section</b>
<b>7.5.1.</b>	<b>Subsection</b>
<b>7.5.1.6.</b>	<b>Article</b>
<b>7.5.1.6.(1)</b>	<b>Sentence</b>
<b>7.5.1.6.(1)(e)</b>	<b>Clause</b>
<b>7.5.1.6.(1)(e)(i)</b>	<b>Subclause</b>

Generally a reference to a requirement of the NBC includes the name of the division and the full number, i.e., Sentence 7.4.11.4.(2). Where a reference is made to Sentence (2) the reference is to Sentence (2) of the same Article.

Tables that form part of the National Building Code are printed in bold-face type and retain the same numbering system as in the Code, i.e., they are numbered according to the Subsection in which they occur, followed by a capital letter, e.g., Table 7.4.11.D. Tables that form part of the explanatory material have been assigned Figure numbers to differentiate between tables in the explanatory material and those in the Code.

The following symbols and abbreviations have been used in the figures:

Drainage pipe	Subsoil drains
Water pipe	Vent pipe
BG Bathroom group	LT Laundry tray
BT Bathtub	RD Roof drain
CO Cleanout	WB Wash basin
DF Drinking fountain	WC Water closet
FD Floor drain	

Chapter I contains the definitions from Part 2 of the NBC that are related to plumbing. Chapter II makes up the main body of this Code and contains the complete Part 7 of the NBC 1970.

Appendixes A, B, C, and D are excerpts from Parts 1, 3, 5, and 9 respectively from the NBC 1970 which are essential for a full understanding and application of this Code. In these excerpts there are a few references to Sections and Articles, etc., that have not been included in the Appendix. None of these references is required in the use of plumbing requirements.

Appendix E, Table of Rainfall Intensities, is taken from Supplement No. 1 to the National Building Code 1970 and is required for the design of storm drainage systems.

# CHAPTER I

## DEFINITIONS AND ABBREVIATIONS

Definitions and abbreviations in this Chapter have been taken from Part 2 of the National Building Code of Canada 1970. Those that are not directly applicable to plumbing systems have not been included.

### SECTION 2.1 DEFINITIONS OF WORDS AND PHRASES

#### SUBSECTION 2.1.1. GENERAL

**2.1.1.1.** The words and terms in italics in this Code shall have the meanings assigned to them in this Chapter.

**2.1.1.2.** For definitions of words used in this Code that are not included in this Chapter, reference should be made to a standard dictionary such as "Webster's Third New International Dictionary (1961)."

*Air gap* means the vertical distance between the lowest point of a water supply outlet and the flood level rim of the fixture or device into which the outlet discharges.

See Fig. 32, p. 48 and Fig. 75, p. 97.

*Alloyed zinc* means an alloy of zinc having the corrosion resistance and physical properties of an alloy containing 0.15 per cent titanium, 0.74 per cent copper and 99.11 per cent zinc and so tempered as to be capable of being formed into the shape required for a watertight joint.

*Alteration* (as applying to a building) means a change from one major occupancy class or division to another, or a structural change such as an addition to the area or height, or the removal of part of a building, or any change to the structure such as the construction of, cutting into or removal of any wall, partition, column, beam, joist, floor or other support, or a change to or closing of any required means of egress or a change to the fixtures, equipment, cladding or trim where they are regulated by this Bylaw.

*Appliance* (as applying to plumbing systems) means a receptacle or equipment that receives or collects water, liquids or sewage and discharges water, liquids or sewage either directly or indirectly to a plumbing system.

See also the definition of fixture.

*Appropriate authority having jurisdiction* means the departments of the provincial governments and agents thereof that have authority over the subject that is regulated.

*Approved means approved by the authority having jurisdiction or the appropriate authority having jurisdiction.*

*Assembly occupancy* means the occupancy or use of a building, or part thereof, by a gathering of persons for civic, political, travel, religious, social, educational, recreational or like purposes, or for the consumption of food or drink.

*Authority having jurisdiction* means the municipal council and the agent thereof that have authority over the subject that is regulated.

*Back-siphonage* means the flow-back of water from a plumbing fixture or vessel or other source into a water supply pipe due to negative pressure in such pipe.

Figure 1 shows a situation that is fairly common in old buildings. If the bathtub is filled to a level above the faucet outlet, or if the flush valve of the water closet is faulty, and if the faucet at the sink or washbasin on the lower floor is opened, water can be drawn (siphoned) from the bathtub or the water closet into the water system when the pressure in the water system is low or the water supply has been shut off.

Back-siphonage can be prevented in situations such as those shown by providing an air gap or a back-siphonage preventer (see Subsection 7.6.2).

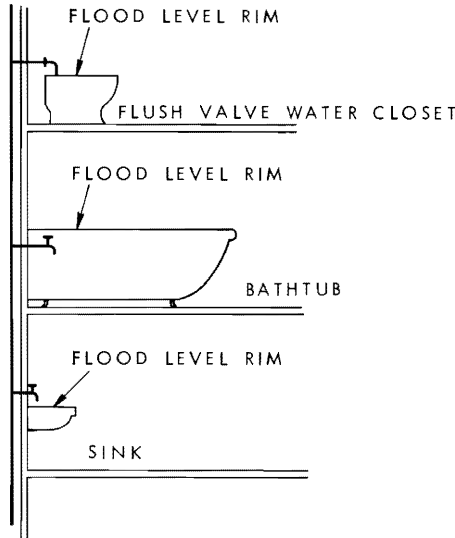

Figure 1 Back-siphonage

**Back-siphonage preventer (or vacuum breaker)** means a device that is installed in a water supply system to prevent flow-back into the system when the pressure in the system is less than atmospheric.

See Fig. 2.

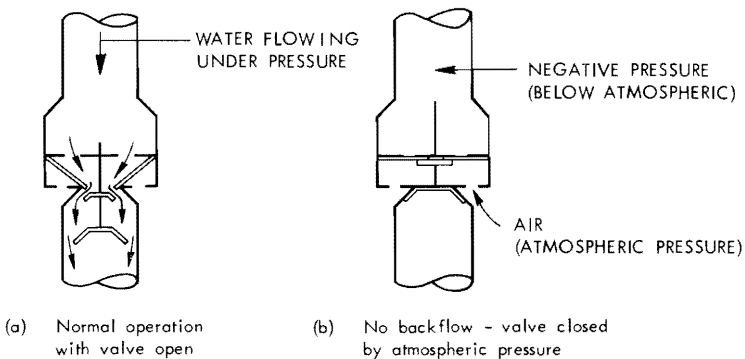

Figure 2 Typical back-siphonage preventer

**Backflow** means the flow of water or other liquids, mixtures or substances into the distributing pipes of a supply of *potable* water from any source other than its intended source and may be produced by the differential pressure existing between two systems either or both of which are at pressures greater than atmospheric.

**Backflow connection** means any connection or condition that may permit *backflow*.

**Backflow preventer** means a device or a method to prevent *backflow* caused by gravity or back pressure into a *potable* water supply.

See Fig. 3.

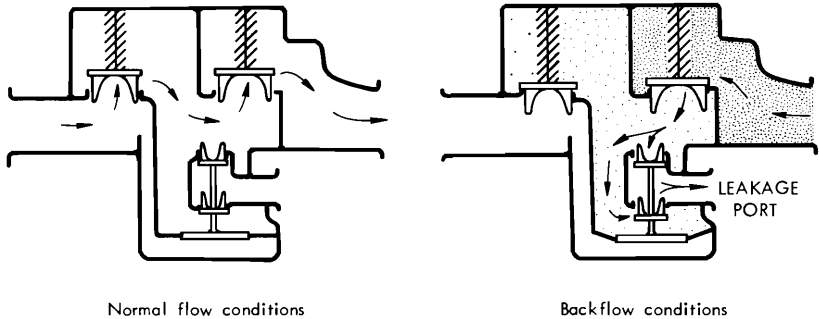

(a) Reduced pressure backflow preventer

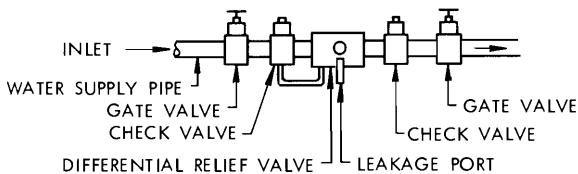

(b) Assembly of differential valves and check valves used as a backflow preventer

Figure 3 Typical backflow preventers

**Branch** (as applying to *plumbing systems*) means a *soil-or-waste pipe* located in 1 storey, connected at its upstream end to the junction of 2 or more *soil-or-waste pipes* or to a *soil-or-waste stack*, and connected at its downstream end to another *branch*, a *soil-or-waste stack* or a *building drain*.

See Fig. 16, p. 15.

**Branch vent** (as applying to *plumbing systems*) means a *vent pipe* that is connected at its lower end to the junction of 2 or more *vent pipes* and is connected at its upper end either to a *stack vent*, *vent stack* or *header*, or is terminated in open air.

A header is similar to a branch vent, but a header serves the special purpose of connecting the tops of stack vents or vent stacks. See Fig. 4; and Fig. 15, p. 14.

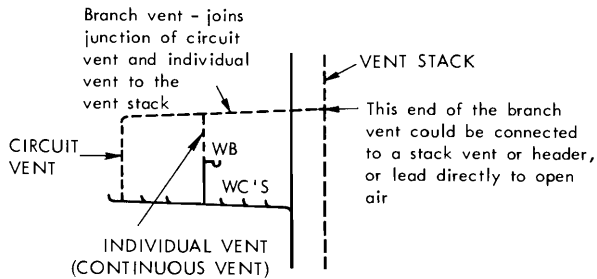

Figure 4 Branch vent

**Building** means any structure used or intended for supporting or sheltering any use or occupancy.

**Building drain** means that part of the lowest horizontal piping that conducts sewage, clear-water waste or storm water to a building sewer.

See Fig. 15, p. 14 and Fig. 16, p. 15.

**Building sewer** means a pipe that is connected to a building drain 3 feet outside a wall of a building and that leads to a public sewer or private sewage disposal system.

**Building subdrain** means that part of a drainage system that cannot drain by gravity into the building sewer.

**Building-trap** means a trap that is installed in a building drain or building sewer to prevent circulation of air between a drainage system and a public sewer.

**Business and personal services occupancy** means the occupancy or use of a building or part thereof for the transaction of business or the rendering or receiving of professional or personal services.

**Circuit vent** (as applying to plumbing systems) means a vent pipe that is connected at its lower end to a branch and at its upper end to a vent stack or terminates in open air.

Note that although a circuit vent (or loop vent) is defined as being connected at the lower end to a branch, in fact it is required, by Sentence 7.5.1.8.(1) to connect between the two most upstream fixtures as shown in Fig. 5. This means that in some instances the circuit or loop vent is connected to the upstream fixture drain.

See Fig. 4, and Fig. 15, p. 14.

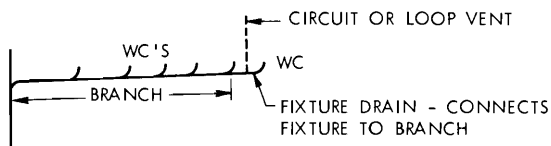

Figure 5 Circuit or loop vent connection

**Cleanout** (as applying to *plumbing systems*) means a pipe fitting that is intended to provide access to a pipe to permit pipe cleaning.

**Clear-water waste** means clear water that does not contain *sewage* or *storm water*.

Examples of clear-water waste are the waters discharged from a drinking fountain, cooling jacket, air conditioner, or relief valve outlet.

**Closure** means a device for shutting off an opening through a construction assembly, such as a door or a shutter, and includes all components such as hardware, closing devices, frames and anchors.

**Combined building drain** means a *building drain* that is intended to conduct *sewage* and *storm water*.

**Combined building sewer** means a *building sewer* that is intended to conduct *sewage* and *storm water*.

**Combined sewer** means a sewer that is intended to conduct *sewage* and *storm water*.

**Combustible** (as applying to an elementary building material) means that such material fails to conform to CSA B54.1-1960 (as amended October 1969), "Determination of Noncombustibility in Building Materials" or to ASTM E136-65, "Noncombustibility of Elementary Materials."

**Continuous vent** (as applying to *plumbing systems*) means a *vent pipe* that is an extension of a vertical section of a *branch* or *fixture drain*.

**Critical level** (as applying to *plumbing systems*) means the highest level to which a *back-siphonage preventer*, when subjected to a specified test, can be submerged before *backflow* begins.

**Dead end** (as applying to *plumbing systems*) means a pipe that is 2 feet or more in *developed length* and terminates with a closed fitting.

**Developed length** (as applying to *plumbing systems*) means the length along the centre line of a pipe.

See Fig. 56(c), p. 76.

**Diameter** (as applying to *plumbing systems*) unless otherwise indicated means the nominal diameter by which a pipe, fitting, *trap* or other item is commercially designated.

**Directly connected** (as applying to *plumbing systems*) means physically connected in such a way that water or gas cannot escape from the connection.

**Drain** (see *building drain* and *building subdrain*).

**Drainage system** (as applying to *plumbing systems*) means an assembly of pipes, fittings, fixtures, traps and appurtenances that is used to convey *sewage*, *clear-water waste* or *storm water* to a public sewer or a *private sewage disposal system* but does not include *subsoil drainage pipes*.

See Fig. 15, p. 14 and Fig. 16, p. 15.

**Dual vent** (as applying to *plumbing systems*) means a *continuous vent* or *stack vent* that serves 2 fixtures that are connected at the same level to the *branch* or *soil-or-waste stack* of which the *vent pipe* is an extension.

See Fig. 15, p. 14.

**Dwelling unit** means 1 or more rooms for the use of 1 or more persons as a house-keeping unit with cooking, eating, living, sleeping and sanitary facilities.

**Effective opening** (as applying to *plumbing systems*) means an opening that has a cross-sectional area equal to the minimum area through which water is discharged at a

**discharge opening, control valve inlet or control valve seat of a water supply inlet to a fixture or device.**

Diameter of effective opening: where the effective opening is not circular its "diameter" is the diameter of a circle of the same cross-sectional area. See Fig. 6.

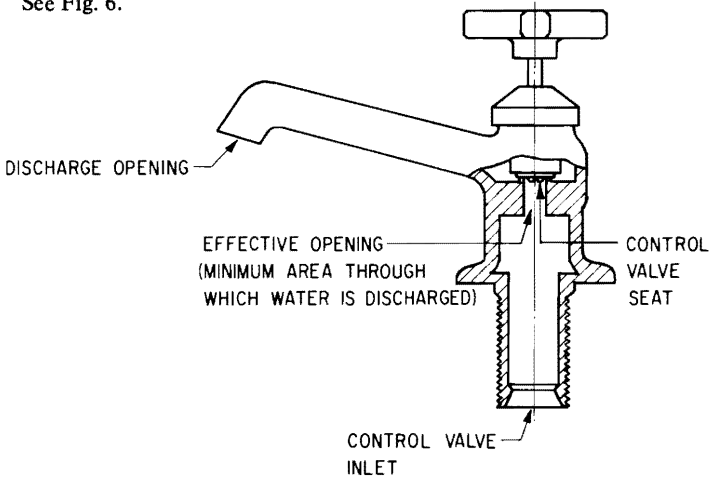

Figure 6 Effective opening

**Fire separation** means a construction assembly that acts as a barrier against the spread of fire. (A fire separation may or may not be required to have a fire-resistance rating or a fire-protection rating.)

**Fire stop** means a draft-tight barrier within or between construction assemblies that acts to retard the passage of smoke and flame.

**Fixture** (as applying to plumbing systems) means a receptacle, appliance, apparatus or other device that discharges sewage or clear-water waste and includes a floor drain.

Any fixture that is movable such as a washing machine or portable dishwasher is considered to be an appliance. (See definition of appliance.)

**Fixture drain** (as applying to plumbing systems) means the pipe that connects a trap serving a fixture to another part of a drainage system.

**Fixture outlet pipe** (as applying to plumbing systems) means a pipe that connects the waste opening of a fixture to the trap serving the fixture.

See Fig. 7.

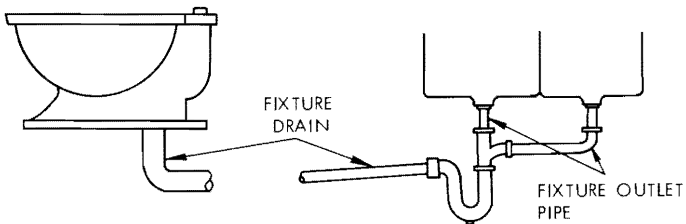

Figure 7 Fixture drains and fixture outlet pipes

**Fixture unit (as applying to plumbing systems)** means a measure of the hydraulic load of a fixture on a drainage system.

A fixture unit is a measure — based on the rate of discharge, time of operation, and frequency of use of a fixture — that expresses the hydraulic load that is imposed by that fixture on the drainage system. See additional explanation on p. 67.

**Flood level rim (as applying to plumbing systems)** means the top edge at which water can overflow from a fixture or device.

See Fig. 1, p. 2.

**Fresh air inlet (as applying to plumbing systems)** means a vent pipe that is connected at its lower end to a building drain and is extended through the wall of a building to terminate in outside air.

See Fig. 15, p. 14.

**Frost-proof closet (as applying to plumbing systems)** means a water closet that has no water in the bowl and has a trap and water control valve that are designed for installation below the frost line.

**Header (as applying to plumbing systems)** means a vent pipe that is installed to connect the upper end of 1 or more vent stacks or stack vents to a vent stack, stack vent or open air.

Although a header is similar to a branch vent, it serves the special purpose of connecting the tops of stack vents or vent stacks. To make certain that it is adequate for that purpose it is made larger than a branch vent. The developed length used to determine its size is the total length from the most distant soil-or-waste pipe to open air, rather than the shorter length used to size a branch vent. See Fig 8.

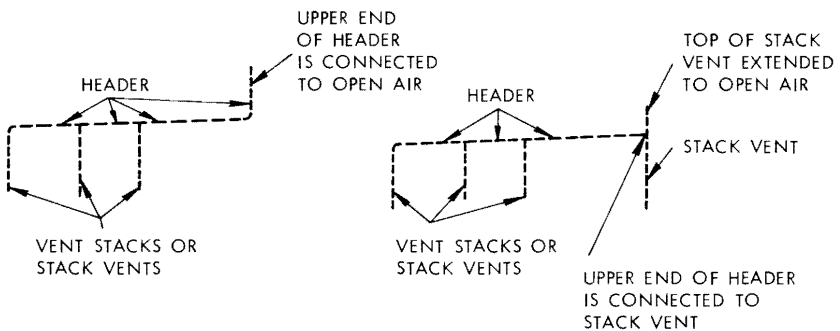

Figure 8 Headers

**Indirect service water heater (see service water heater, indirect).**

**Indirectly connected** means not directly connected to a drainage system.

See Fig. 31, p. 47, and Fig. 32, p. 48.

**Individual vent (as applying to plumbing systems)** means a vent pipe that serves not more than 1 fixture.

**Industrial occupancy** means the occupancy or use of a building or part thereof for assembling, fabricating, manufacturing, processing, repairing or storing of goods and materials.



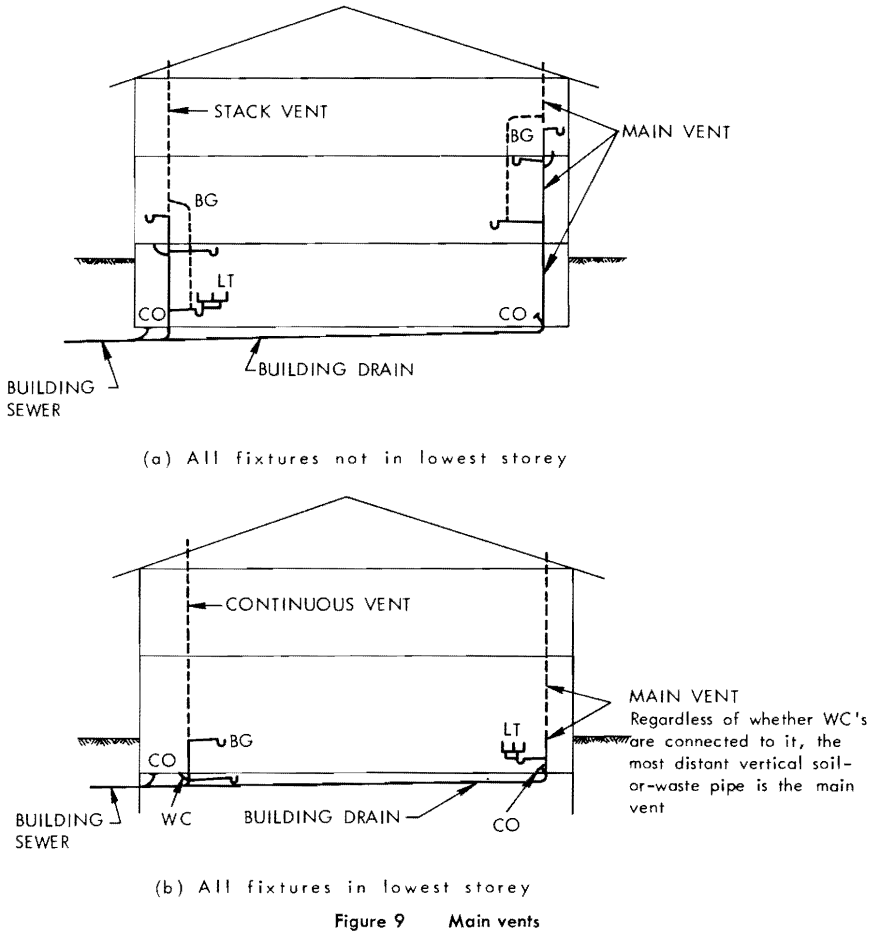

**Institutional occupancy** means the occupancy or use of a building or part thereof by persons harboured or detained to receive medical care or treatment or by persons involuntarily detained.

**Interceptor** means a receptacle that is installed to prevent oil, grease, sand, or other materials from passing into a drainage system.

See Fig. 65, p. 84.

**Leader** means a pipe that is installed to carry storm water from a roof to a storm building drain or sewer or other place of disposal.

See Fig. 51, p. 71.

**Loadbearing** (as applying to a building element) means subjected to or designed to carry loads in addition to its own dead load excepting a wall element subjected only to wind or earthquake loads in addition to its own dead load.

**Loop vent** (as applying to plumbing systems) means a vent pipe that is connected at its lower end to a branch and at its upper end to a stack vent or header or to a branch vent that is connected to a stack vent or header.

See Fig. 15, p. 14.

**Main vent** (as applying to plumbing systems) means the soil-or-waste stack serving 1 or more water closets, that is most distant from the building sewer, together with any vent pipe that joins the top of the stack to open air, except that in a building where fixtures are located only on the lowest storey, main vent means the vertical soil-or-waste pipe that is most distant from the building sewer, together with any vent pipe that connects the top of the pipe to open air.

See Fig. 9

**Mercantile occupancy** means the occupancy or use of a building or part thereof for the displaying or selling of retail goods, wares or merchandise.

**Nominally horizontal** (as applying to plumbing systems) means at an angle of less than 45 degrees with the horizontal.

**Nominally vertical** (as applying to plumbing systems) means at an angle of not more than 45 degrees with the vertical.

See Fig. 10.

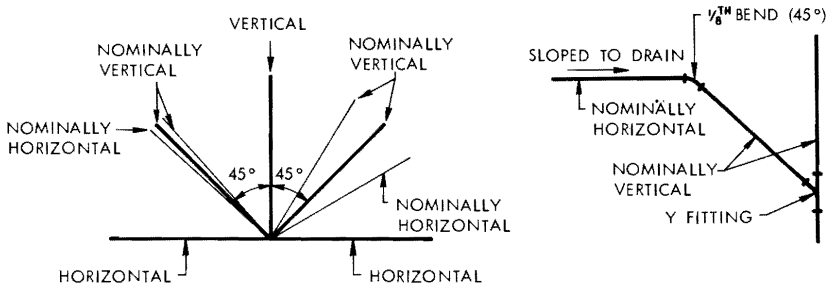

Figure 10 Nominally horizontal and vertical pipes

**Noncombustible** (as applying to an elementary building material) means that such material conforms to CSA B54.1-1960 (as amended October 1969), "Determination of Noncombustibility in Building Materials," or to ASTM E136-65, "Noncombustibility of Elementary Materials."

**Noncombustible construction** means that type of construction in which a degree of fire safety is attained by the use of noncombustible materials for structural members and other building assemblies.

**Occupancy** means the use or intended use of a building or part thereof for the shelter or support of persons, animals or property.

**Occupancy, major** means the principal *occupancy* for which a *building* or part thereof is used or intended to be used, and shall be deemed to include the subsidiary *occupancies* which are an integral part of the principal *occupancy*.

**Occupant load** means the number of persons for which a *building* or part thereof is designed.

**Offset** (as applying to *plumbing systems*) means a combination of elbows or bends that brings one section of the pipe out of line but into line parallel with another section.

See Fig. 11.

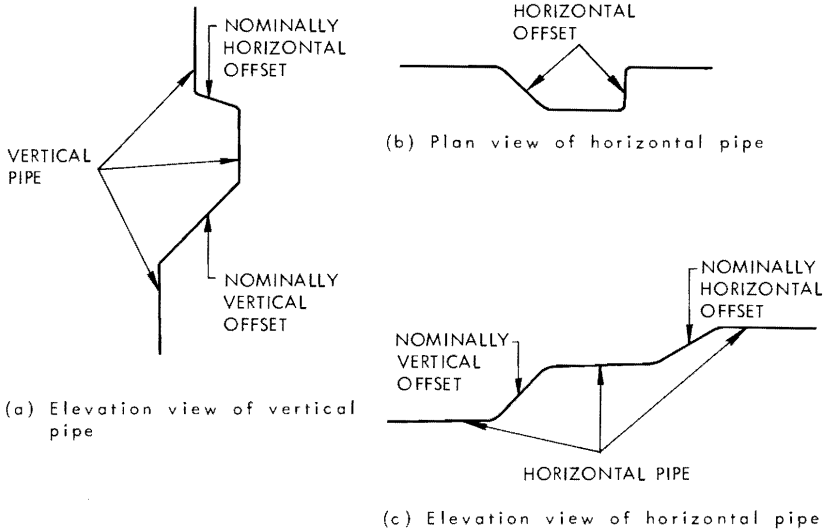

Figure 11 Offsets

**Owner** means any person, firm or corporation controlling the property under consideration.

**Partition** means an interior wall, one *storey* or *part-storey* in height that is not load-bearing.

**Permit** means permission or authorization in writing by the *authority having jurisdiction* to perform work regulated by this Code and, in the case of an occupancy permit, to occupy any *building* or part thereof.

**Plumbing contractor** means a person, corporation or firm that undertakes to construct, extend, alter, renew or repair any part of a *plumbing system*.

**Plumbing system** means a *drainage system*, a *venting system* and a *water system*.

See Fig. 12.

**Potable** means safe for human consumption.

**Private sewage disposal system** means a privately owned plant for the treatment and disposal of *sewage* (such as a septic tank with an absorption field).

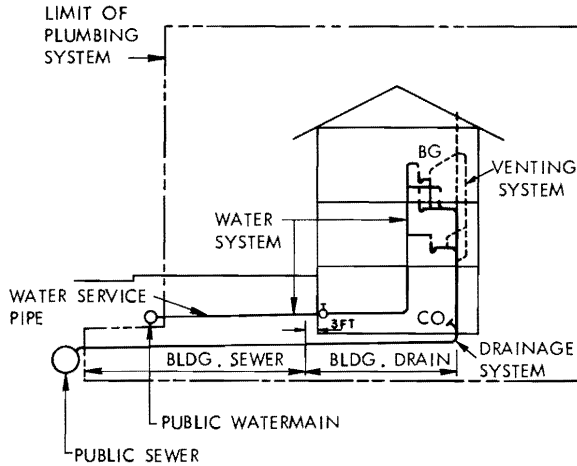

Figure 12 Plumbing system

**Relief vent** (as applying to plumbing systems) means a vent pipe that is connected at its lower end to a nominally horizontal branch and at its upper end to a branch vent, header, stack vent or vent stack, or is terminated in open air.

See Fig. 15, p. 14.

**Residential occupancy** means the occupancy or use of a building or part thereof by persons for whom sleeping accommodation is provided but who are not harboured or detained to receive medical care or treatment or are not involuntarily detained.

**Sanitary building drain** means a building drain that may conduct sewage and clear-water waste, but not storm water.

**Sanitary building sewer** means a building sewer that may conduct sewage and clear-water waste, but not storm water.

**Sanitary drainage system** means a drainage system that may conduct sewage or clear-water waste, and includes a combined building drain and combined building sewer.

**Sanitary sewer** means a sewer that may conduct sewage or clear-water waste but not storm water.

**Service water heater** means an appliance intended for the heating of water for plumbing services as distinct from water for space heating.

**Service water heater, indirect** means a service water heater that derives its heat from a heating medium such as warm air, steam or hot water.

**Service water heater, storage type** means a service water heater with an integral hot water storage tank.

**Sewage** means liquid waste that contains animal, mineral or vegetable matter.

**Size** (as applying to plumbing systems) unless otherwise indicated means the nominal size by which a pipe, fitting, trap or other item is commercially designated.

**Soil-or-waste pipe** means a pipe in a sanitary drainage system.

**Soil-or-waste stack** means a vertical soil-or-waste pipe that passes through 1 or more storeys, and includes any offset that is part of the stack.

**Stack vent** means a vertical vent pipe that is an extension of a soil-or-waste stack.

See Fig. 15, p. 14.

**Storage-type service water heater** (see service water heater, storage type).

**Storey** (as applying to plumbing systems) means the interval between 2 successive floor levels, or floor level and roof beginning at the lowest gravity soil-or-waste pipe.

The first storey begins with the first floor above the level of the building drain.  
See Fig. 13.

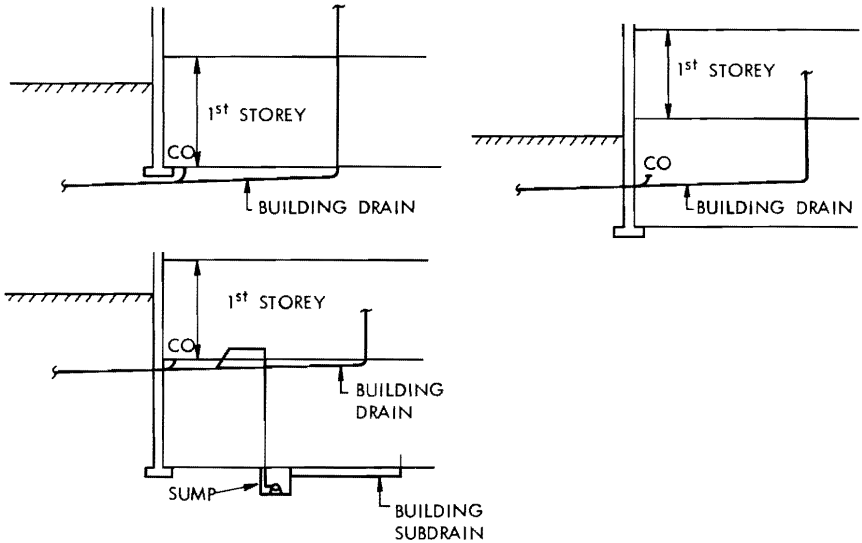

Figure 13 First storey

**Storm building drain** means a building drain that may conduct only storm water or clear-water waste.

**Storm building sewer** means a building sewer that may conduct only storm water or clear-water waste.

**Storm drainage system** means a drainage system or a part of a drainage system that conveys only storm water or clear-water waste.

**Storm sewer** means a sewer that is installed to convey storm water.

**Storm water** means water that is discharged from a surface as a result of rainfall or snowfall.

**Subsoil drainage pipe** means a pipe that is installed underground to intercept and convey groundwater.

**Sump** means a tank or pit that receives and holds the discharge from a *drainage system pipe*.

See Fig. 13, p. 12.

**Trap** (as applying to *plumbing systems*) means a fitting or device that is designed to hold a liquid seal that will prevent the passage of gas but will not materially affect the flow of a liquid.

**Trap dip** (as applying to *plumbing systems*) means the lowest part of the upper interior surface of a trap.

**Trap seal** (as applying to *plumbing systems*) means the vertical distance between the trap dip and the trap weir.

**Trap weir** (as applying to *plumbing systems*) means the highest part of the lower interior surface of a trap.

See Fig. 14.

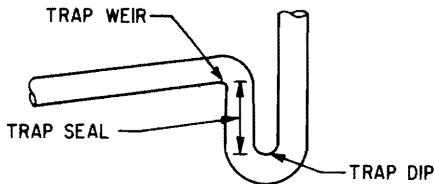

Figure 14 Parts of a trap

**Vacuum breaker** (as applying to *plumbing systems*) (see *back-siphonage preventer*).

**Vent pipe** (as applying to *plumbing systems*) means a pipe that is a part of a *venting system*.

**Vent stack** (as applying to *plumbing systems*) means a vertical *vent pipe* that is connected at its lower end to a *soil-or-waste stack* or to a *building drain* and is connected at its upper end either to a *stack vent* or *header*, or is terminated in open air.

See Fig. 15, p. 14.

**Venting system** (as applying to *plumbing systems*) means an assembly of pipes and fittings that connects a *drainage system* with outside air for circulation of air and the protection of *trap seals* in the *drainage system*.

**Vertical service space** means a shaft oriented essentially vertically that is provided in a *building* to facilitate the installation of building services including mechanical, electrical, plumbing installations and facilities such as elevators, refuse chutes and linen chutes.

**Waste pipe** (see *soil-or-waste pipe*).

**Water service pipe** means a pipe in a *water system* that conveys water from a public water main or a private water source to the inner side of the wall or floor through which the system enters the *building*.

**Water system** means an assembly of pipes, fittings, control valves and appurtenances

that conveys water from a public main or private water source to the water supply outlets of fixtures or devices, and includes a private water source.

*Wet vent* (as applying to plumbing systems) means a soil-or-waste pipe that also serves as a vent pipe.

See Fig. 58, p. 78.

*Yoke vent* (as applying to plumbing systems) means a vent pipe that is connected at its lower end to a soil-or-waste stack and at its upper end to a vent stack or a branch vent that is connected to a vent stack.

See Article 7.5.2.3.

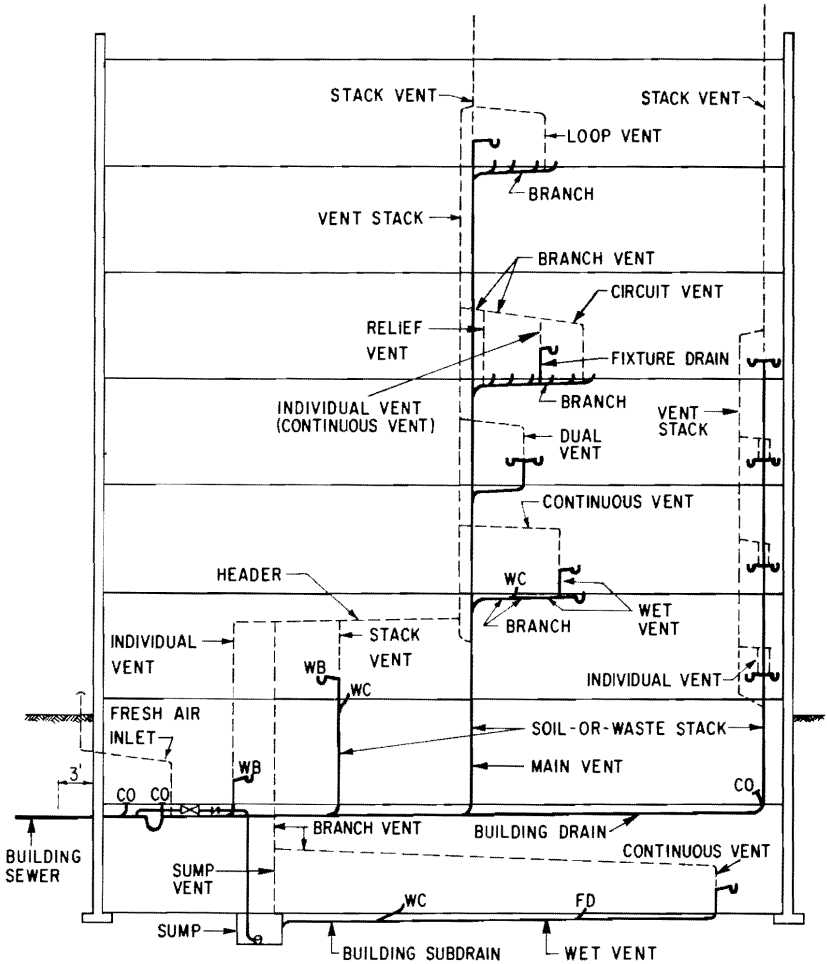

Figure 15 Drainage and venting system

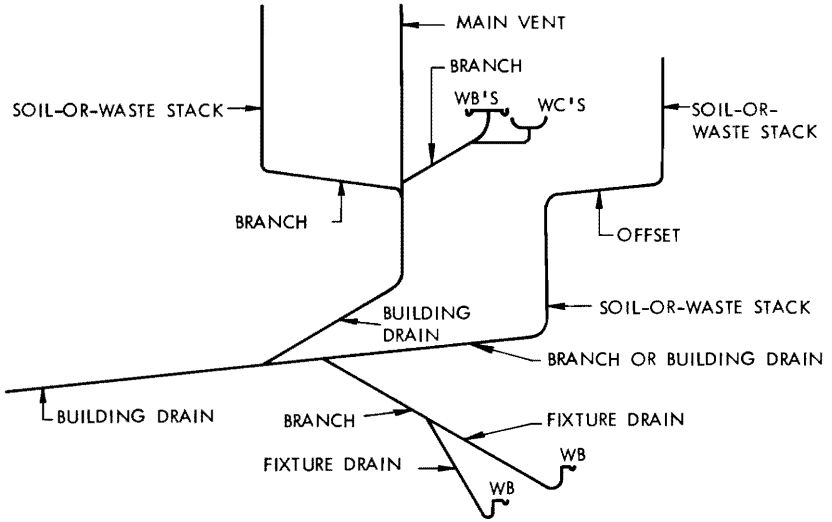

Figure 16 Drainage system (Isometric view)



## SECTION 2.2 ABBREVIATIONS

### SUBSECTION 2.2.1. ABBREVIATIONS OF NAMES OF ASSOCIATIONS

2.2.1.1. The abbreviations in this Code for the names of associations shall have the meanings assigned to them in this Subsection.

<b>ANSI</b>	<b>American National Standards Institute</b>
<b>ASHRAE</b>	<b>American Society of Heating, Refrigerating and Air-Conditioning Engineers</b>
<b>ASTM</b>	<b>American Society for Testing and Materials</b>
<b>CGSB</b>	<b>Canadian Government Specifications Board</b>
<b>CSA</b>	<b>Canadian Standards Association</b>

### SUBSECTION 2.2.2. ABBREVIATIONS OF WORDS AND PHRASES

2.2.2.1. The abbreviations of words and phrases in this Code shall have the meanings assigned to them in this Subsection

<b>ABS</b>	<b>acrylonitrile-butadiene-styrene</b>
<b>°C</b>	<b>degree(s) Celsius</b>
<b>deg.</b>	<b>degree(s)</b>
<b>diam.</b>	<b>diameter</b>
<b>°F</b>	<b>degree(s) Fahrenheit</b>
<b>ft</b>	<b>foot (feet)</b>
<b>ft/sec</b>	<b>foot (feet) per second</b>
<b>gal.</b>	<b>gallon(s)</b>
<b>gpm</b>	<b>gallon(s) per minute</b>
<b>hr</b>	<b>hour(s)</b>
<b>in.</b>	<b>inch(es)</b>
<b>kg</b>	<b>kilogram(s)</b>
<b>kN</b>	<b>kilo Newton(s)</b>
<b>l</b>	<b>litre(s)</b>
<b>lb</b>	<b>pound(s)</b>
<b>max.</b>	<b>maximum</b>
<b>m</b>	<b>metre(s)</b>
<b>m<sup>2</sup></b>	<b>square metre(s)</b>
<b>mm</b>	<b>millimetre(s)</b>
<b>min.</b>	<b>minimum</b>
<b>min.</b>	<b>minute(s)</b>
<b>N</b>	<b>Newton(s)</b>
<b>N/m</b>	<b>Newton(s) per metre</b>
<b>N/m<sup>2</sup></b>	<b>Newton(s) per square metre</b>
<b>No.</b>	<b>number(s)</b>
<b>oz</b>	<b>ounce(s)</b>
<b>psf</b>	<b>pound(s) per square foot</b>
<b>psi</b>	<b>pound(s) per square inch</b>
<b>psig</b>	<b>pound(s) per square inch gauge</b>
<b>PVC</b>	<b>polyvinyl chloride</b>
<b>sq ft</b>	<b>square foot (feet)</b>
<b>sq in.</b>	<b>square inch(es)</b>
<b>temp.</b>	<b>temperature</b>

## CHAPTER II

# PLUMBING SERVICES

Requirements in this Chapter are in bold-face type and are identical to those of Part 7 of the National Building Code of Canada 1970.

## SECTION 7.1 GENERAL REQUIREMENTS

### SUBSECTION 7.1.1. APPLICATION

**7.1.1.1.** Every *plumbing system* shall conform to the appropriate Provincial plumbing regulations. In the absence of such regulations the requirements of this Code shall apply.

**7.1.1.2.** This Code applies to the construction, extension, *alteration*, renewal or repair of *plumbing systems* in every building.

### SUBSECTION 7.1.2. SCOPE

**7.1.2.1.** This Code specifies the minimum requirements for the supply of *potable water* to a building, the removal of water-borne wastes from a *building* to a public sewer or *private sewage disposal system*, and the removal of *storm water*.

### SUBSECTION 7.1.3. DEFINITIONS

**7.1.3.1.** Words that appear in italics are defined in Chapter 1 of this Code.

### SUBSECTION 7.1.4. PERMITS

**7.1.4.1.(1)** Except as provided in Sentence (2), a *plumbing system* shall not be constructed, extended, altered, renewed or repaired or a connection made to a sewer unless a *permit* to do so has been obtained.

(2) A *permit* is not required when a *fixture*, valve or faucet is repaired or replaced, a stoppage cleared or a leak repaired if no change to the piping is required.

(3) An application for a *permit* shall be made to a plumbing inspector or other official who is appointed by the *authority having jurisdiction*.

(4) A *permit* shall be issued only to a *plumbing contractor* who meets the qualifications that are prescribed in . . .\*

**7.1.4.2.(1)** An application for a *permit* shall be made on the form that is provided by the *authority having jurisdiction*.

**Application  
for permit**

Sentences marked (\*) will vary with local practice and space is left for the reference.

(2) Every application shall be accompanied by

- (a) the fee that is set forth in . . . \*, and
- (b) a specification or description of proposed work.

(3) Where the installation consists of more than five *fixtures*, the application shall also be accompanied by

- (a) a plan that shows the location and *size* of every *building drain*, and of every *trap* or inspection piece that is on a *building drain*, and
- (b) a sectional drawing that shows the *size* and location of every *soil-or-waste pipe, trap and vent pipe*.

(4) Where a *permit* has been issued, no departure shall be made from the specification, description, plan or sectional drawing unless written permission is obtained from the *authority having jurisdiction*.

Validity  
of permit

7.1.4.3. A *permit* is valid . . . \* months after it is issued.

### SUBSECTION 7.1.5. INSPECTION AND TESTING

Inspection  
and testing  
of new or  
altered  
materials

7.1.5.1.(1) Where a *permit* is required as described in Subsection 7.1.4., the system shall not be put into use until it has been inspected or tested to the satisfaction of the *authority having jurisdiction*.

(2) The *plumbing contractor* shall notify the *authority having jurisdiction* when the work is complete and ready to be inspected or tested.

(3) The *plumbing contractor* shall furnish any equipment, material, power or labour that is necessary for inspection or testing.

(4) No part of any *plumbing system* shall be covered until it is inspected and approved.

(5) If any part of a *plumbing system* is covered before it is inspected and approved it shall be uncovered if the *authority having jurisdiction* so directs.

(6) If any part of a *plumbing system* is not approved after it is inspected or tested the *plumbing contractor* shall make any *alteration* or replacement that is necessary and the work shall be subjected to further inspection or testing.

Inspection  
of existing  
systems

7.1.5.2.(1) The *authority having jurisdiction* may inspect an existing *plumbing system* in any *building* and where there is reason to suspect that the system is not satisfactory order it to be tested.

(2) If any part of the system is in a condition that is, or may become, dangerous or injurious to health, the *owner* shall make any *alteration* or replacement that is ordered in writing by the *authority having jurisdiction*.

Certificate  
of approval

7.1.5.3. When a *plumbing system* has been completed and has been approved, the *authority having jurisdiction*, when requested, shall issue a certificate of approval to the *owner* and to the *plumbing contractor*.

Responsibility  
of contractor

7.1.5.4. The granting of a *permit*, the approval of a specification or plan, or an inspection or test that is made by the *authority having jurisdiction* does not in any way relieve the *plumbing contractor* of full responsibility for carrying out work on a *plumbing system* in complete accordance with this Code.

Sentences marked (\*) will vary with local practice and space is left for the reference.

## SECTION 7.2 MATERIALS

### SUBSECTION 7.2.1. GENERAL

See Appendix C for list of standards to which materials must conform and for other requirements including the use of alternative materials.

7.2.1.1. Every material, including a *fixture*, shall be free from defects that affect its usefulness for its intended purposes.

Defects in materials

7.2.1.2. Where unusual conditions exist such as excessively corrosive soil or water, only materials suited for use in such locations shall be used.

Exposure of materials

7.2.1.3.(1) A used material, including a *fixture*, shall not be re-used unless the written consent of the *authority having jurisdiction* has been received.

Restrictions on re-use

(2) A material that has been used for a purpose other than the distribution of *potable water* shall not be re-used in a *potable water system*.

7.2.1.4. Every length of pipe and every fitting shall have cast, stamped, or indelibly marked on it the maker's name or mark and the weight or class or quality of the product, or it shall be marked in accordance with the relevant standard. Such markings shall be visible after installation.

### SUBSECTION 7.2.2. FIXTURES

7.2.2.1. Every vitreous china or vitreous glazed earthenware *fixture* shall conform to CSA B45.1-1963, "Vitreous China Plumbing Fixtures."

Vitreous china or earthenware fixtures

7.2.2.2.(1) Except as permitted in Sentence (2), the following *fixtures* shall be made of vitreous china, vitreous glazed earthenware, enameled cast-iron or enameled steel, or other material having an equally smooth, hard, corrosion-resistant surface free from flaws and blemishes that may interfere with cleaning:

Materials for fixtures

- (a) water closet bowl,
- (b) urinal,
- (c) wash basin,
- (d) bathtub,
- (e) drinking fountain,
- (f) *fixture* that is intended for use in the preparation of food or drink,
- (g) medical or hospital *fixture*,
- (h) sink,
- (i) *fixture* that is intended for a use that is related to personal hygiene, and
- (j) laundry tray except as specified in Sentence (4).

(2) Every *fixture* that is intended for a special purpose shall be made of a material *approved* for that purpose.

Special purpose fixtures

(3) Every shower receptor shall be made of a material that is smooth, hard, corrosion-resistant and can be readily cleaned.

Shower receptor

**Concrete laundry tray**

- (4) A laundry tray may be made of concrete if
  - (a) the concrete is strong and dense,
  - (b) the tray is moulded in one piece,
  - (c) the corners of the tray are rounded inside and out,
  - (d) the thickness of the sides and partitions is at least 1½ in. (29 mm) at the top and 1¼ in. (32 mm) at the bottom, and
  - (e) the thickness of the bottom is at least 1¼ in. (32 mm).

**Diameter of waste opening**

7.2.2.3. The *diameter* of the waste opening of a *fixture* shall conform to Table 7.2.2.A.

**Table 7.2.2.A.  
Forming Part of Article 7.2.2.3.**

<i>Fixture</i>	<i>Min. Diameter of Waste Opening, in.</i>
Bathtub	1½
Laundry tray (each compartment)	1½
Sink (except laboratory sink)	1½
Shower receptor —	
Serving one head	1½
Serving 2 or 3 heads	2
Serving 4 to 6 heads	3
Wash basin	1¼
Water closet	3
<b>Column 1</b>	<b>Column 2</b>

**Area of strainer**

7.2.2.4.(1) Where a strainer, other than the cross-bar type, is installed in a waste opening of a *fixture*, it shall provide an outlet area that is at least equal to the area of the waste opening.

(2) Where a cross-bar type strainer is installed in a waste opening of a *fixture*, the outlet area shall be at least 60 per cent of the area of the waste opening.

**Construction of overflow**

7.2.2.5.(1) Except as provided in Sentence (2), where an overflow is installed on a *fixture* it shall be constructed so that

- (a) the area of the overflow and the overflow pipe or passage is at least one half the area of the waste opening of the *fixture*,
- (b) the overflow pipe or passage is connected to the *fixture outlet pipe*, and
- (c) the overflow pipe can be readily and effectively cleaned.

(2) Every overflow for a wash basin shall conform to the appropriate requirements of CSA B45.1-1963, "Vitreous China Plumbing Fixtures."

(3) A concealed-type overflow shall not be installed on a sink other than a laboratory sink.

A concealed-type overflow is an overflow that is an integral part of the fixture, such as on a wash basin. The Code does not require an overflow on a fixture but where an overflow is installed, it must conform to this Article.

- 7.2.2.6.(1) Every water closet bowl shall be constructed**
- (a) in one piece with an integral *trap* and flushing rim,
  - (b) so that it is capable of meeting the flushing test set forth in CSA B45.1-1963, "Vitreous China Plumbing Fixtures," and
  - (c) so that the flushing rim will flush the entire inside surface of the bowl, and the capacity of the bowl below the *trap weir* shall be sufficient to prevent fouling of the the surface of the bowl.
- (2) Every floor outlet bowl shall be of the siphon-jet, blowout, washdown or reverse-trap type.
- (3) A *frost-proof closet* shall not be used.
- 7.2.2.7.(1) Every urinal shall be constructed as a one-piece *fixture*.**
- (2) Every urinal shall have an integral flushing rim, except that a washout-type wall urinal may be equipped with a flush spreader.
- (3) Every urinal of the siphon-jet, blowout or pedestal type shall have an integral *trap*.
- (4) Every stall urinal shall have a spud by which it can be connected to a tail piece.
- 7.2.2.8. A trough urinal shall not be used.**
- 7.2.2.9.(1) The *diameter* of a spud or a flush pipe for a water closet tank shall be at least**
- (a) 2 in (51 mm) when the bottom of the tank is not more than 2 ft (610 mm) above the floor, and
  - (b) 1½ in. (38 mm) when the bottom of the tank is more than 2 ft (610 mm) above the floor.
- 7.2.2.10.(1) Every direct flush valve shall**
- (a) open fully and close positively under service pressure,
  - (b) complete its cycle of operation automatically,
  - (c) be provided with a means of regulating the volume of water that it discharges, and
  - (d) be provided with a *vacuum breaker*.
- 7.2.2.11.(1) The orifice of every drinking fountain shall**
- (a) be of the shielded type, and
  - (b) direct the water upward at an angle of approximately 45 deg.
- (2) Every drinking fountain shall include a means of regulating the flow to the orifice.
- (3) Every drinking fountain shall be a separate *fixture*.
- Sentence (3) is not intended to exclude three bubblers on one drinking fountain but is intended to exclude a bubbler installed on a wash basin.
- 7.2.2.12.(1) Every shower receptor shall be constructed and arranged so that water cannot leak through the walls or floor.**

Construction of water closet bowl

Construction of urinals

Diameter of flush tank spud and flush pipe

Direct flush valve

Drinking fountain orifice

Shower receptor

(2) Not more than six shower heads shall be served by a single waste opening.

(3) Where two or more heads are served by an opening the floor shall be sloped, and the opening located so that water from one head cannot flow over the area that serves another head.

See Fig. 17.

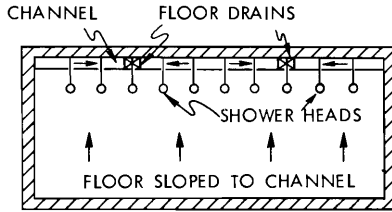

(a) Permitted

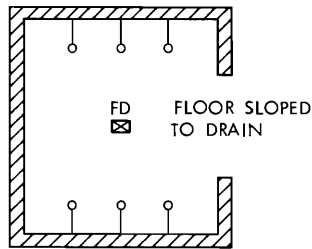

(b) Not permitted

Figure 17 Shower drainage

(4) The smallest interior dimension of a receptor shall be not less than 30 in. (762 mm).

(5) When shower heads are installed in series the distance between two adjacent shower heads shall be not less than 30 in. (762 mm).

### SUBSECTION 7.2.3. TRAPS AND INTERCEPTORS

#### Traps

#### 7.2.3.1.(1) Every trap shall

- (a) have a trap seal not less than 1½ in. (38 mm) except that the trap seal of a floor drain shall be not less than 4 in. (102 mm),
- (b) be self-cleaning,
- (c) have no partitions, and
- (d) have a water seal that does not depend on the action of moving parts.

- (2) Every trap that serves a wash basin, a sink or a laundry tray shall
- (a) be provided with a cleanout plug located at the lowest point of the trap and of the same material as the trap except that cast-iron trap shall be provided with a brass cleanout plug, or
  - (b) be designed so that part of the trap can be completely removed by screwed connections for cleaning purposes.

See Fig. 18.

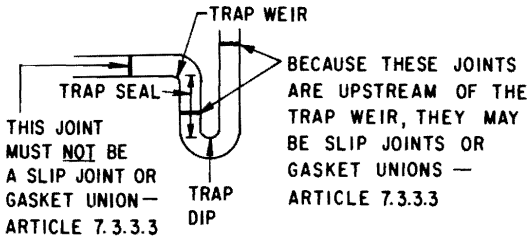
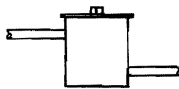

Figure 18 Trap seal and trap connections

- (3) Every building-trap and every trap that serves a leader or a subsoil drainage pipe shall be installed with a cleanout in accordance with Sentence 7.4.9.6.(8).
- (4) Every lead trap shall conform to CSA B67-1941, "Lead Service Pipe, Waste Pipe, Traps, Bends and Accessories."
- (5) A bell trap or a drum trap shall not be used.

Except for an S trap standard, S traps and  $\frac{3}{4}$  S traps shown in Fig. 19(c) are prohibited by Clause 7.5.1.3.(1)(a) which limits the fall on fixture drains. Crown vented traps shown in Fig. 19(d) are prohibited by Clause 7.5.1.3.(1)(b) which requires that the distance from the trap weir to the vent be not less than twice the diameter of the fixture drain.



(a) Drum trap



(b) Bell trap



(c) S trap and  $\frac{3}{4}$  S trap

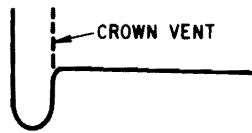

(d) Crown vented trap

Figure 19 Prohibited traps



**Interceptors** 7.2.3.2.(1) Every *interceptor* shall be designed so that it can be readily cleaned.

(2) Every grease *interceptor* shall be designed so that it does not become air bound and it shall not have a water jacket.

#### SUBSECTION 7.2.4. FITTINGS

**General** 7.2.4.1.(1) Every fitting shall be constructed so that it does not offer unnecessary obstruction to flow.

(2) Except for a water closet bend or flange, a fitting that has a reduction in area in the downstream direction shall not be used in a *drainage system* downstream of a *trap*.

**T or cross fitting** 7.2.4.2.(1) A T or a cross fitting shall not be used in a *drainage system* except to connect a *vent pipe*.

This prohibits the use of a cross fitting in a drainage system but such fitting may be used in a venting system to connect four vent pipes. In a drainage system a T fitting can only be used as shown in Fig. 20(a) and cannot be used as shown in Fig. 20(b) because the T (or cross) fitting would change the direction of flow in the drainage system.

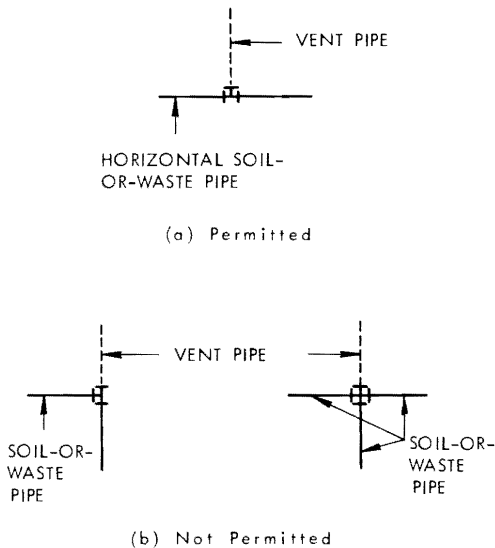
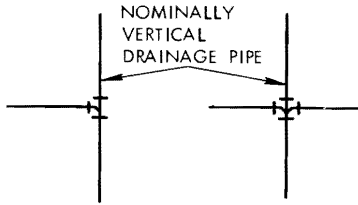

Figure 20 T fittings in drainage systems

**Sanitary T-Y** (2) A sanitary T-Y fitting shall not be used in a *nominally horizontal pipe* in a *drainage system* except to connect a *vent pipe*.

A sanitary T-Y fitting may be used to connect a nominally horizontal soil-or-waste pipe to a nominally vertical soil-or-waste pipe (see Fig. 21(a)). A sanitary T-Y fitting may be used to connect a vent pipe to a nominally horizontal or nominally vertical soil-or-waste pipe (see Fig. 21(b)). A sanitary T-Y fitting may not be used to connect any soil-or-waste pipe to a nominally horizontal soil-or-waste pipe (see Fig. 21(c)). This connection should be made with a Y and 1/8 bend.



(a) Permitted

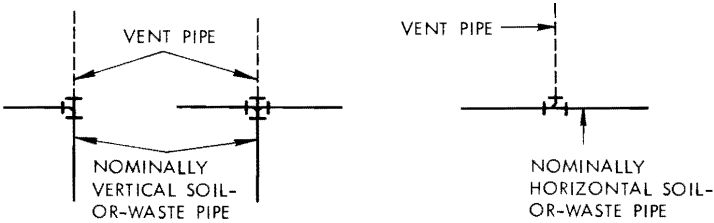

(b) Permitted

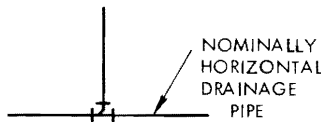

(c) Prohibited (use Y and 1/8<sup>TH</sup> bend)

Figure 21 Sanitary T-Y fittings in drainage systems

**7.2.4.3. The major leg diameter of a double Y or a double Y and 1/8th bend fitting used in a nominally horizontal soil-or-waste pipe shall be at least 2 in. (51 mm).**

**Double Y**

See Fig. 22, p. 26.

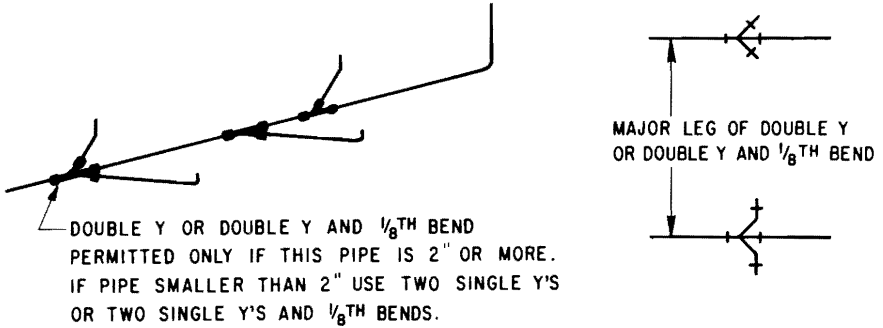

Figure 22 Double Y fittings

**Y and  $\frac{1}{8}$  bend**

**7.2.4.4.** A single or double Y and  $\frac{1}{8}$ th bend fitting shall not connect a vertical vent pipe or a vertical soil-or-waste pipe that serves as a vent pipe to a fixture drain having a diameter 2 in. (51 mm) or less.

Sentence 7.5.1.4.(1) requires that the connection described in this Article be made with a sanitary T-Y fitting.

**Quarter bend**

**7.2.4.5.** A quarter bend that has a centreline radius that is less than the diameter of the pipe shall not be used to join two soil-or-waste pipes.

**Sisson fitting**

**7.2.4.6.** A sisson fitting shall not be installed in a nominally horizontal soil-or-waste pipe.

**SUBSECTION 7.2.5. NON-METALLIC PIPE AND FITTINGS**

For a summary of pipe applications see Fig. 23, p. 31. For restrictions on the use of combustible pipe see Appendixes B and D.

**Asbestos-cement drainage pipe and fittings**

**7.2.5.1.(1)** Asbestos-cement drainage pipe, couplings and fittings shall conform to

- (a) CGSB 34-GP-9c, 1969, "Pipe: Asbestos-Cement, Sewer," or
- (b) CGSB 34-GP-22, 1966, "Pipe: Asbestos-Cement, Drain."

(2) Every rubber ring used with asbestos-cement pipe fittings shall be made of moulded and vulcanized rubber compound.

(3) Except as provided in Sentence (4) asbestos-cement drainage pipe shall not be used except for the underground part of a drainage system.

(4) Asbestos-cement drainage pipe may be used

- (a) in a non-habitable space where the pipe is suspended adjacent to ground level and conforms to the medium and heavy grades specified in CGSB 34-GP-22, 1966, and
- (b) for a rain-water leader where the pipe conforms to CGSB 34-GP-22, 1966.

**Asbestos-cement water pipe and fittings**

**7.2.5.2.(1)** Asbestos-cement water pipe, couplings and bends shall conform to CGSB 34-GP-1b, 1969, "Pipe, Asbestos-Cement Pressure."

(2) Asbestos-cement water pipe shall not be used above ground.

**7.2.5.3.(1) Bituminized fibre pipe, couplings and bends shall conform to CGSB 56-GP-1a, 1962, "Pipe, Bituminized-Fibre, Drain and Sewer."** **Bituminized fibre pipe and fittings**

(2) Bituminized fibre pipe shall not be permitted except for the following uses:

- (a) storm drainage pipe,
- (b) *subsoil drainage pipe*, and
- (c) *a building sewer serving one or two dwelling units.*

**7.2.5.4.(1) Concrete pipe shall conform to "standard strength non-reinforced" concrete sewer pipe as specified in ASTM C14-68, "Concrete Sewer, Storm Drain and Culvert Pipe."** **Concrete pipe**

(2) Every branch shall be securely and completely fastened to the barrel of the concrete pipe in the process of manufacture.

This clause prohibits the use of concrete pipe fittings made on-site from straight lengths of pipe.

(3) Concrete pipe shall not be used in or under a *building*.

**7.2.5.5.(1) Vitrified clay pipe shall conform to CSA A60.1 and A60.3-1969, "Vitrified Clay Pipe" and "Vitrified Clay Pipe Joints."** **Vitrified clay pipe**

(2) Vitrified clay pipe shall not be used except for an underground part of a *drainage system*.

**7.2.5.6.(1) Polyethylene water pipe shall conform to CSA B137-1963, "Polyethylene Pipe for Cold Water Services."** **Plastic pipe and fittings**

(2) Polyethylene water pipe shall not be used except for a *water service pipe*.

**7.2.5.7.(1) Plastic sewer pipe and pipe fittings for use underground shall conform to CSA B182.1-1967, "Plastic Drain and Sewer Pipe and Pipe Fittings for Use Underground."**

(2) Plastic pipe and fittings conforming to Sentence (1) shall not be used except as a sewer pipe.

**7.2.5.8.(1) Acrylonitrile-Butadiene-Styrene (ABS) pipe, fittings and solvent cement for use in drain, waste and vent systems shall conform to CSA B181.1, 1967, "Acrylonitrile-Butadiene-Styrene Drain, Waste and Vent (ABS-DWV) Pipe and Pipe Fittings."**

(2) Polyvinyl Chloride (PVC) pipe, fittings and solvent cement for use in drain, waste and vent systems shall conform to CSA B181.2-1967, "Poly (Vinyl Chloride) Drain Waste and Vent (PVC-DWV) Pipe and Pipe Fittings."

(3) Plastic pipe conforming to Sentences (1) and (2) shall

- (a) not be used in a piping system where such system or part thereof passes through or is enclosed in a required *fire separation*,
- (b) not exceed 36 ft (11 m.) in stack or vent height, and
- (c) not be used in *buildings* required to be of *noncombustible construction*.

### SUBSECTION 7.2.6. FERROUS PIPE AND FITTINGS

See Fig. 23, p. 31, for summary of pipe applications.

- |  |  |
|--|--|
| <b>Cast-iron soil pipe and fittings</b>      | <p>7.2.6.1. Cast-iron soil pipe and fittings shall conform to CSA B70-1963, "Cast Iron Soil Pipe and Fittings," except that the pipe may be manufactured with a beaded spigot on each end.</p> <p>7.2.6.2. Cast-iron fittings designed for use with asbestos-cement pipe for drainage purposes shall conform to CSA B70-1963, "Cast Iron Soil Pipe and Fittings."</p>                        |
| <b>Threaded cast-iron pipe</b>               | <p>7.2.6.3.(1) Threaded cast-iron pipe shall conform to ANSI A40.5-1943, "Threaded Cast-Iron Pipe for Drainage, Vent and Waste Services."</p> <p>(2) Threaded cast-iron pipe shall not be used in a <i>water system</i>.</p>   |
| <b>Screwed cast-iron drainage fittings</b>   | <p>7.2.6.4.(1) Screwed cast-iron drainage fittings shall conform to ANSI B16.12-1965, "Cast Iron Threaded Drainage Fittings."</p> <p>(2) Screwed cast-iron drainage fittings shall not be used in a <i>water system</i>.</p>   |
| <b>Cast-iron water pipe</b>                  | <p>7.2.6.5. Cast-iron water pipe shall conform to:</p> <p>CSA B131.5-1963, "Cast Iron Pipe Centrifugally Cast in Molds for Water or Other Liquid";</p> <p>CSA B131.7-1963, "Cast Iron Pipe Centrifugally Cast in Sand-Lined Molds for Water or Other Liquid"; and</p> <p>CSA B131.11-1958, "Universal Cast Iron Pipe and Fittings Cast in Sand-Lined Molds for Water and Other Liquids."</p> |
| <b>Cast-iron screwed water fittings</b>      | <p>7.2.6.6.(1) Screwed cast-iron water fittings shall conform to ANSI B16.4-1963, "Cast Iron Screwed Fittings, 125 and 250 lb."</p> <p>(2) Screwed cast-iron water fittings used in a <i>water system</i> shall be cement lined or galvanized.</p> <p>(3) Screwed cast-iron water fittings shall not be used in a <i>drainage system</i>.</p>  |
| <b>Malleable iron screwed water fittings</b> | <p>7.2.6.7.(1) Screwed malleable iron water fittings shall conform to ANSI B16.3-1963, "Malleable Iron Screwed Fittings 150 and 300 lb."</p> <p>(2) Screwed malleable iron water fittings used in a <i>water system</i> shall be cement lined or galvanized.</p> <p>(3) Screwed malleable iron water fittings shall not be used in a <i>drainage system</i>.</p>                             |
| <b>Wrought-iron pipe</b>                     | <p>7.2.6.8.(1) Wrought-iron pipe shall conform to "Standard Weight Pipe" as set forth in CSA B62-1965, "Welded Genuine Wrought Iron Pipe," and shall</p> <p>(a) be galvanized, and</p> <p>(b) be used with couplings of wrought iron.</p> <p>(2) Wrought-iron pipe shall not be used underground.</p>  |
| <b>Steel pipe</b>                            | <p>7.2.6.9.(1) Welded and seamless steel pipe shall conform to CSA B63-1966, "Welded and Seamless Steel Pipe."</p> <p>(2) Corrugated steel pipe shall conform to ASTM A444-67, "Zinc-Coated (Galvanized) Iron or Steel Sheets for Culverts and Underdrains" and shall</p>  |

- (a) be galvanized, and
- (b) be used with couplings of wrought iron, steel or malleable iron.

(3) Every coupling for corrugated steel pipe shall be fabricated from material conforming to ASTM A444-67. Every coupling shall be constructed so that when installed, it provides adequate jointing to preserve the pipe alignment, resist separation of adjoining pipe sections, and prevent root penetration or infiltration of fill material.

(4) Steel pipe shall not be used underground except that corrugated steel pipe may be used outside a *building* in a *storm drainage system* that is connected to a public *storm sewer* or open drain.

7.2.6.10.(1) Where open-hearth iron pipe is used, it shall be galvanized.

**Open-hearth iron pipe**

(2) Open-hearth iron pipe shall not be used underground in a *drainage system* or *venting system*.

7.2.6.11. A sheet metal *leader* shall not be used except above ground outside a *building*.

**Sheet metal leader**

**SUBSECTION 7.2.7. NON-FERROUS PIPE AND FITTINGS**

See Fig. 23, p. 31, for summary of pipe applications.

7.2.7.1. Copper and brass pipe shall conform to CSA HC.7.5-1968, "Seamless Copper and Red Brass Pipes."

**Copper and brass pipe**

7.2.7.2. Brass or bronze pipe flanges and flanged fittings shall conform to ANSI B16.24-1962, "Bronze Flanges and Flange Fittings, 150 and 300 lb."

**Brass or bronze flanges and flanged fittings**

7.2.7.3.(1) Brass or bronze screwed water fittings shall conform to ANSI B16.15-1964, "Cast Bronze Screwed Fittings, 125 and 250 lb."

**Brass or bronze screwed water fittings**

(2) Brass or bronze screwed water fittings shall not be used in a *drainage system*.

7.2.7.4.(1) Copper tube shall conform to the types specified in CSA HC.7.6-1968, "Seamless Copper Water Tube, Drainage Tube (DWV) and Hydronic Heating Tube (Type H)," and shall be restricted to the following uses:

**Copper tube**

- (a) Type K, plumbing purposes,
- (b) Type L, any part of a *water system*, or any part of a *drainage system* within or under a *building*,
- (c) Type M, above-ground *water systems*,
- (d) Type DWV, drainage, wastes and vents located above ground, and
- (e) Soft (annealed) copper tube shall not be used except in *water systems*.

(2) The wall thickness of fittings used with the copper tube designated in Sentence (1) shall not be less than the wall thickness of the tube.

7.2.7.5.(1) Cast-brass or cast-bronze solder-joint drainage fittings shall conform to ANSI B16.23-1969, "Cast Bronze Solder-Joint Drainage Fittings."

**Cast brass solder-joint drainage fittings**

(2) A cast-brass or cast-bronze solder-joint drainage fitting shall not be used in a *water system*.

- Forged solder-joint fittings** 7.2.7.6. Forged solder-joint fittings shall conform to ANSI B16.18-1963 (1967 Addendum), "Cast Brass Solder-Joint Fittings."
- Solder-joint water fittings** 7.2.7.7. Solder-joint water fittings shall conform to ANSI B16.18-1963 (1967 Addendum), "Cast Brass Solder-Joint Fittings," or ANSI B16.22-1963, "Wrought Copper and Bronze Solder-Joint Pressure Fittings."
- Flared joint fittings** 7.2.7.8. Every fitting for a flared joint shall conform to ANSI B.16.26-1967, "Cast Bronze Fittings for Flared Copper Tube."
- Lead waste pipe and bends** 7.2.7.9.(1) Lead *waste pipe* shall conform to "strong" pipe and lead bends shall conform to "heavy" bends as set forth in CSA B67-1964, "Lead Service Pipe, Waste Pipe, Traps, Bends and Accessories," except that hard lead (16 per cent antimony) may be used.
- (2) Lead *waste pipe* and bends shall be made of lead that weighs at least 8 lb/sq ft.
- (3) When there is a change in *diameter* of a lead closet bend, the change shall be in the vertical section of the bend or made in such a manner that there shall be no retention of liquid in the bend.
- (4) Lead *waste pipe* and bends shall not be used in a *water system* or for a *building sewer*.
- Lead water pipe** 7.2.7.10(1) Lead water pipe shall conform to CSA B67-1964, "Lead Service Pipe, Waste Pipe, Traps, Bends and Accessories."
- (2) Lead water pipe shall not be used for a *building sewer*.

USE OF PIPE	Drainage System			Venting System		Water System			Code Reference
	Above ground inside building	Underground inside building	Building sewer	Above ground	Underground	Above ground	Underground inside building	Underground outside building	
TYPE OF PIPE									
Asbestos cement drainage pipe	1	O	O	X	X	X	X	X	7.2.5.1.
Asbestos cement water pipe	X	O	O	X	O	X	O	O	7.2.5.2.
Bituminized fibre	2	2	3	X	X	X	X	X	7.2.5.3.
Concrete	X	X	O	X	X	X	X	NA	7.2.5.4.
Vitrified clay	X	O	O	X	X	X	X	X	7.2.5.5.
Polyethylene water pipe	X	X	X	X	X	X	4	4	7.2.5.6.
Plastic sewer pipe	X	X	O	X	X	X	X	X	7.2.5.7.
Acrylonitrile — Butadiene — Styrene (ABS)	5	5	O	5	5	NA	NA	NA	7.2.5.8.
Poly Vinyl Chloride (P.V.C.)	5	5	O	5	5	NA	NA	NA	7.2.5.8.
Cast iron soil pipe	O	O	O	O	O	NA	NA	NA	7.2.6.1.
Threaded cast iron	O	O	O	O	O	X	X	X	7.2.6.3.
Cast iron water pipe	O	O	O	O	O	O	O	O	7.2.6.5.
Wrought iron	O	X	X	O	X	O	X	X	7.2.6.8.
Welded and seamless steel	O	X	X	O	X	O	X	X	7.2.6.9.
Corrugated steel	O	X	6	NA	X	NA	X	X	7.2.6.9.
Open hearth iron pipe	O	X	X	O	X	O	NA	NA	7.2.6.10.
Sheet metal	7	X	X	X	X	X	X	X	7.2.6.11.
Copper and brass	O	O	O	O	O	O	O	O	7.2.7.1.
Copper tube — Type K	O	O	O	O	O	O	O	O	7.2.7.4.
Copper tube — Type L	O	O	X	X	X	O	O	O	7.2.7.4.
Copper tube — Type M	X	X	X	X	X	O	X	X	7.2.7.4.
Copper tube — Type DWV	O	X	X	O	X	X	X	X	7.2.7.4.
Copper tube — Type Soft (Annealed)	X	X	X	X	X	O	O	O	7.2.7.4.
Lead waste pipe	O	O	X	O	O	X	X	X	7.2.7.9.
Lead water pipe	NA	NA	X	NA	NA	O	O	O	7.2.7.10.

Figure 23 Summary of pipe applications

Notes to Fig. 23

X — Not permitted.

O — Permitted.

NA — Not applicable.

1. Permitted only (a) where it is suspended adjacent to ground in a non-habitable space, or (b) where it is used for a rainwater leader.
2. Permitted only for storm drainage.
3. Permitted only to serve one or two dwelling units.
4. Permitted only for water service pipe.
5. Not permitted where (a) the piping system or part thereof passes through a fire separation, or (b) the stack or vent height exceeds 36 ft, or (c) the building is required to be of noncombustible construction.
6. Permitted only outside a building in a storm drainage system that is connected to a public storm sewer or open drain.
7. Permitted only for an exterior leader.



## SUBSECTION 7.2.8. JOINTING MATERIALS

- Cement jointing mortar** 7.2.8.1. Cement mortar for jointing shall be a mixture of equal parts of clean sharp mortar sand and portland cement. The mortar shall be mixed at least 20 minutes and not more than 1 hour before it is used.
- Hot-poured caulking compounds** 7.2.8.2.(1) Hot-poured caulking compounds shall conform to:  
 CGSB 56-GP-2a, 1967, "Sealing Compound; Sewer Pipe Joint, Hot Pour, Mineral Filled, Bituminous," or  
 CGSB 56-GP-3a, 1967, "Sealing Compound; Sewer Pipe Joint, Hot Pour, Mineral Filled, Plastic."  
 (2) Cold caulking compounds shall conform to CGSB 77-GP-1, 1962, "Compound; Pipe Jointing, Cementitious; Cold Applied."
- Solder and caulking lead** 7.2.8.3. Solder and caulking lead shall conform to CSA B67-1964, "Lead Service Pipe, Waste Pipe, Traps, Bends and Accessories."
- Saddle hub** 7.2.8.4. A saddle hub shall not be used.

## SUBSECTION 7.2.9. MISCELLANEOUS MATERIALS

- Brass floor flanges** 7.2.9.1.(1) Brass floor flanges shall conform to ANSI B16.23-1969, "Cast Bronze Solder-Joint Drainage Fittings."
- Bolts, nuts, etc.** (2) Every bolt, nut and washer for a floor flange and every closet screw shall be of heavy brass.
- Cleanout ferrule** 7.2.9.2.(1) The thickness of the body of every cleanout ferrule shall be not less than the thickness that is specified for a pipe of the same material.  
 (2) The length of every cleanout ferrule shall be such that the cover plate or plug will project above a hub into which the cleanout ferrule is inserted.  
 (3) Every cleanout ferrule shall be fitted with a threaded brass plug at least  $\frac{1}{8}$  in. (3 mm) thick or with a cover plate fastened with brass bolts and nuts.  
 (4) Every threaded brass plug for a cleanout ferrule shall be provided with a raised integral nut, a recessed socket or a pair of raised studs.  
 (5) Every raised nut of a threaded brass plug shall be at least 1 in. (25 mm) in its smallest horizontal dimension and at least  $\frac{5}{8}$  in. (16 mm) high, and if it is hollow it shall be at least  $\frac{3}{16}$  in. (5 mm) thick.  
 (6) Every recessed socket for a threaded brass plug shall be at least 1 in. (25 mm) in its smallest horizontal dimension and at least  $\frac{1}{2}$  in. (13 mm) deep.  
 (7) Every raised stud for a threaded brass plug shall be at least  $\frac{5}{8}$  in. (16 mm) high.

See Fig. 24.

- Vent flashings** 7.2.9.3.(1) Where stacks or *vent pipes* pass through a roof they shall be equipped with a flashing and the joint between the roof and the pipe or stack shall be made watertight.  
 (2) Flashing for stacks and *vent pipes* shall be of copper, aluminum, alloyed zinc, lead or neoprene.

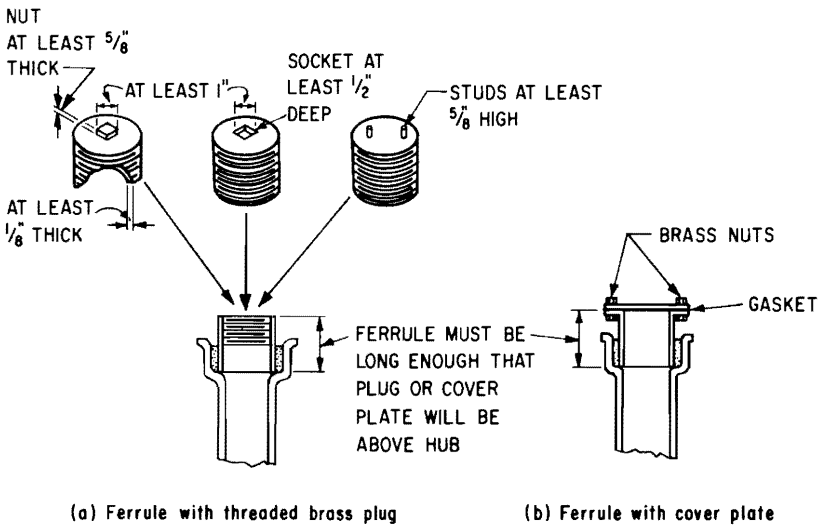

Figure 24 Cleanout ferrules

(3) Except as provided in Sentence (4), flashing shall be rectangular and at least 20 in. (508 mm) in length by 20 in. (508 mm) in width and, where sleeve flashing is used, the sleeve shall be extended at least 6 in. (152 mm) above the roof at every point of the pipe or stack.

(4) On flat roofs a round flashing with a flange of at least 5 in. (127 mm) may be used.

(5) Flashing shall consist of:

- (a) lead sheet weighing not less than 5 lb per sq ft;
- (b) copper sheet weighing not less than 10 oz per sq ft;
- (c) sheet aluminum weighing not less than 5.5 oz per sq ft;
- (d) alloyed zinc sheet weighing not less than 8.1 oz per sq ft; or
- (e) neoprene weighing not less than 0.722 lb per sq ft.

Article 7.5.4.4. specifies the location of vent pipe terminals.

7.2.9.4. Valves and faucets shall conform to CSA B125-1967, "Plumbing Fittings."

Valves and faucets

7.2.9.5. Back-siphonage preventers shall be constructed to conform to ANSI A40.6-1943, "Backflow Preventers in Plumbing Systems."

Back-siphonage preventer

7.2.9.6. Temperature relief, pressure relief, or combined temperature and pressure relief valves shall conform to ANSI Z21.22-1964, "Relief Valves and Automatic Gas Shutoff Devices for Hot Water Supply Systems."

Relief valves

## SECTION 7.3 PIPING

### SUBSECTION 7.3.1. APPLICATION

7.3.1.1.(1) This Section applies to the construction and use of joints and connections, and the arrangement, protection, support and testing of piping.

### SUBSECTION 7.3.2. CONSTRUCTION AND USE OF JOINTS

Caulked lead  
drainage  
joint

7.3.2.1.(1) Every caulked lead drainage joint shall be firmly packed with oakum, and tightly caulked with lead to a depth of at least 1 in. (25 mm).

(2) No paint, varnish or other coating shall be applied on the lead until after the joint has been tested.

(3) Caulked lead drainage joints shall not be used except for cast-iron pipe in a *drainage system* or *venting system*, or between such pipe and

- (a) other ferrous pipe,
- (b) brass and copper pipe,
- (c) a caulking ferrule, or
- (d) a *trap* standard.

7.3.2.2.(1) Wiped joints shall not be used except for sheet lead or lead pipe, or between such pipe and copper pipe or a ferrule.

(2) Every wiped joint in straight pipe shall

- (a) be made of solder,
- (b) have an exposed surface on each side of the joint at least  $\frac{3}{4}$  in. (19 mm) wide, and
- (c) be at least  $\frac{3}{8}$  in. (10 mm) thick at the thickest part.

(3) Every wiped flanged joint shall be reinforced with a lead flange that is at least  $\frac{3}{4}$  in. (19 mm) wide.

Screwed  
joint

7.3.2.3.(1) In making a screwed joint the ends of the pipe shall be reamed or filed out to the size of the bore and all chips and cuttings shall be removed.

(2) No pipe-joint cement or paint shall be applied to the internal threads.

Soldered  
joint

7.3.2.4.(1) In making a soldered joint the surface to be soldered shall be cleaned bright and the joint shall be properly fluxed, made with solder and thoroughly cleaned of all residue.

Flared joint

7.3.2.5.(1) In making a flared joint the pipe shall be expanded with a proper flaring tool.

(2) Flared joints shall not be used for hard (drawn) copper tube.

Hot-poured  
joint

7.3.2.6.(1) Hot-poured joints shall be caulked tightly with twisted oakum and rammed, and a hot-poured caulking compound shall be placed to a depth of at least 1 in. (25 mm) all around the pipe.

(2) Hot-poured joints shall not be used except for vitrified clay or concrete pipe, or between either of such pipes and ferrous pipe.

7.3.2.7.(1) Cement joints in pipe that has a diameter of 6 in. (152 mm) or less shall be made by completely filling the annular space between the hub and the spigot with cement mortar.

Cement joint

(2) Every cement joint in pipe that has a diameter of more than 6 in. (152 mm) shall be made by

- (a) ramming into the annular space between the hub and the spigot a gasket of closely twisted hemp or oakum at least equal in length to the circumference of the pipe, and
- (b) filling the remaining annular space with mortar.

(3) The exterior of every cement joint shall be carefully shaped from the outside of the hub to the barrel of the pipe at an angle of approximately 45 deg.

(4) After every joint is made, the interior of the pipe shall be thoroughly swabbed and cleaned.

(5) Cement joints shall not be used except for vitrified clay or concrete pipe or between either of such pipes and ferrous pipe.

7.3.2.8.(1) In making a burned lead joint the lead shall be lapped and fused to form a weld that is at least 1½ times as thick as the wall of the pipe.

Burned lead joint

(2) In lead pipe the width of the weld shall not be less than

- (a) ½ in. (13 mm) where the diameter of the pipe is less than 3 in. (76 mm),
- (b) ⅝ in. (16 mm) where the diameter of the pipe is 3 in. (76 mm), or
- (c) ¾ in. (19 mm) where the diameter of the pipe is 4 in. (102 mm).

(3) In sheet lead the width of the weld shall be as specified in Table 7.3.2.A.

Table 7.3.2.A.  
Forming Part of Sentence 7.3.2.8.(3)

Weight of Sheet Lead, lb/sq ft	Minimum Width of Weld, in.
2½ to 3	¼
4 to 5	⅜
6 to 8	¾
10 to 12	1
12 to 30	1¼
Column 1	Column 2

7.3.2.9. Mechanical joints shall be made with approved compounded elastomer couplings or rings held by stainless steel or cast-iron clamps or contained within a compression connection and shall only be used to joint vitrified clay pipe, asbestos-cement pipe, cast-iron soil pipe, steel pipe or any other combination of pipes and fittings approved by the authority having jurisdiction.

Mechanical joints

**Cold caulked joints** 7.3.2.10.(1) Cold-caulked joints shall not be used except for bell and spigot pipe in a *water system* or a *drainage system*. The caulking compound shall be applied according to the manufacturer's directions.

(2) Every cold-caulked joint in a *drainage system* shall be firmly packed with oakum and tightly caulked with cold caulking compound to a depth of at least 1 in. (25 mm).

(3) Every cold-caulked joint in a *water system* shall be made by tightly caulking the entire depth of the socket with caulking compound.

### SUBSECTION 7.3.3. JOINTS AND CONNECTIONS

**Drilled and tapped** 7.3.3.1. Drilled and tapped joints shall not be made in a *soil-or-waste pipe* and *vent pipe* and fittings.

**Welded joint** 7.3.3.2. Welding of ferrous metals shall not be permitted.

**Unions and slip joints** 7.3.3.3. Unions with a gasket seat, including a long thread and packing nut connection, or slip joints, shall not be used downstream of a *trap weir* in a *drainage system* nor in a *venting system*.

See Fig. 18, p. 23.

**Increaser or reducer** 7.3.3.4. Every connection between two pipes of different *size* shall be made with an increaser or a reducer fitting installed so that it will permit the system to be completely drained.

**Burned lead** 7.3.3.5. Every joint in hard lead shall be made with a burned lead joint.

**Dissimilar connections** 7.3.3.6.(1) Every joint between pipes and fittings of dissimilar material or sizes shall be made by adaptors, connectors or mechanical joints manufactured for the purpose.

(2) Every joint between plastic pipe and cast-iron hub and spigot pipe shall be made with a cold caulking compound.

(3) Connections of ABS and PVC to lead stubs and bends may be used providing the connection is made with ABS and PVC pipe respectively.

**Connection of roof hopper to leader** 7.3.3.7. Every roof hopper shall be securely connected to a *leader* and provision shall be made for expansion.

**Connection of floor outlet fixtures** 7.3.3.8.(1) Every pedestal urinal, floor-mounted water closet, or *S-trap* standard shall be connected to a *fixture drain* by a floor flange, except that a cast-iron *trap* standard may be caulked to a cast-iron pipe.

(2) Except as provided in Sentences (3) and (4), every floor flange shall be of brass.

(3) A cast-iron floor flange may be used to connect a water closet located on a concrete basement floor to a cast-iron *fixture drain*.

(4) Where plastic pipe is used a floor flange of the same material may be used.

(5) Every floor flange shall be securely set on a firm base and bolted to the trap flange of the fixture, and every joint shall be sealed with a natural rubber, synthetic rubber or asbestos graphite gasket, or with a closet setting compound.

(6) Where a lead water closet stub is used the length of the stub below the floor flange shall be at least 3 in. (76 mm).

(7) Where plastic pipe is used, expansion joints shall be installed immediately above the base of the stack.

**SUBSECTION 7.3.4. SERVICE PIPING**

7.3.4.1. Piping in any building shall be connected to the public services separately from the piping of any other building, except that ancillary buildings on the same property may be served by the same service.

Separate piping for individual buildings

In Fig. 25, the layout shown in (a), (b) and (c) are permitted but that shown in (d) is not permitted. The layouts shown in Fig. 25(c) may in some jurisdictions require special legal arrangements to ensure that access can be provided to all parts of the service pipes. See Fig. 25, p. 38.

**SUBSECTION 7.3.5. SUPPORT OF PIPING**

7.3.5.1. Piping shall be provided with support that is capable of keeping the pipe in alignment and bearing the weight of the pipe and its contents.

Capability of support

7.3.5.2. Every pipe that is connected to a fixture, tank or device shall be supported independent of it.

Independence of support

7.3.5.3 Where a hanger or support for copper tube or brass or copper pipe is of a material other than brass or copper it shall be suitably separated and electrically insulated from the pipe.

Insulation of support

7.3.5.4.(1) Except as provided in Sentences (2) and (3), vertical piping shall be supported at the base at the floor level of alternate storeys by metal rests, each of which can bear the weight of pipe that is between it and the metal rest above it.

Support for vertical piping

(2) The maximum spacing of supports shall be 25 ft (7.6 m).

(3) Where hub and spigot cast-iron pipe is used each hub shall rest on a support.

7.3.5.5.(1) Nominally horizontal piping that is inside a building shall be braced to prevent swaying and buckling and to control the effects of thrust.

Support for horizontal piping

(2) Nominally horizontal piping shall be supported so that

(a) galvanized iron or steel pipe and copper pipe is supported at intervals of

(i) 12 ft (3.7 m) or less if the pipe diameter is 6 in. (152 mm) or more, and

(ii) 8 ft (2.4 m) or less if the pipe diameter is less than 6 in. (152 mm);

(b) lead pipe is supported throughout its length;

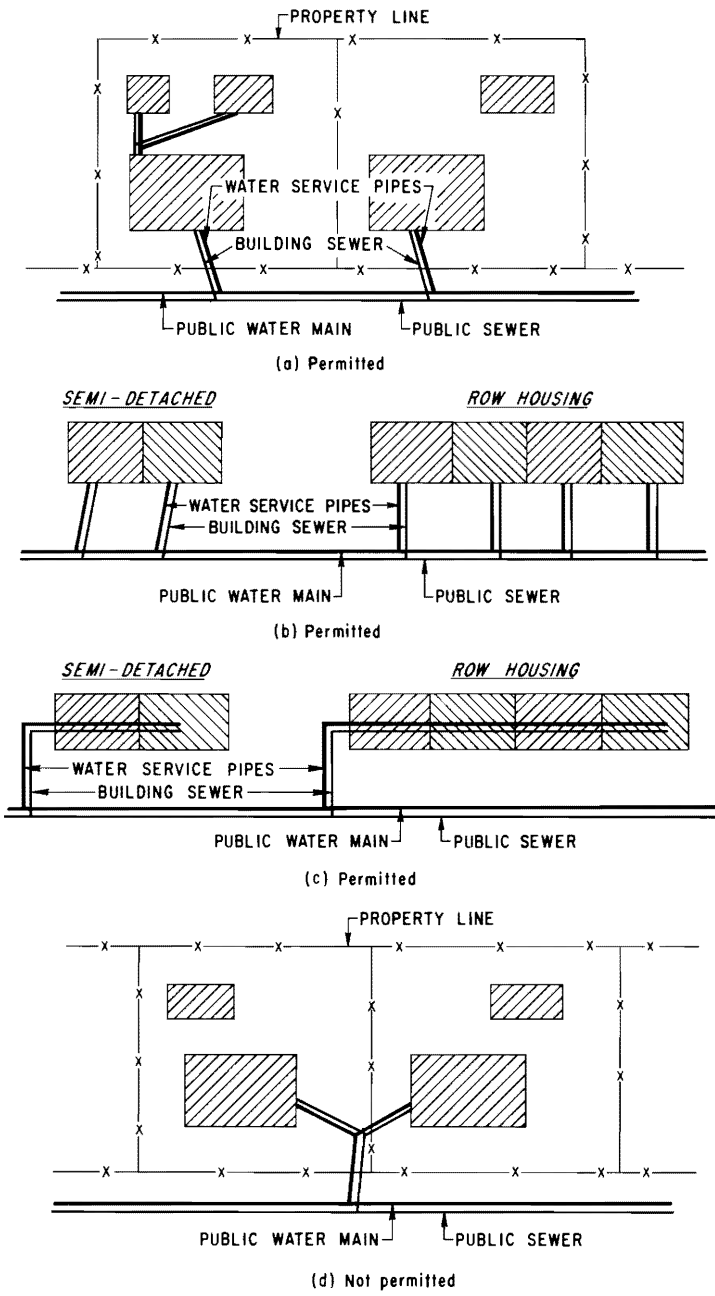

Figure 25 Service piping

- (c) cast-iron pipe is supported
    - (i) at or adjacent to each hub or joint,
    - (ii) at intervals not exceeding 5 ft (1.5 m), and
    - (iii) at intervals not exceeding 3 ft (915 mm) if the pipe has mechanical joints and the length of pipe between adjacent fittings is 12 in. (305 mm) or less;
  - (d) asbestos-cement pipe is supported
    - (i) adjacent to each joint,
    - (ii) at intervals not exceeding 6½ ft (2 m), and
    - (iii) at intervals not exceeding 3 ft (915 mm) where the length of pipe between adjacent fittings is 12 in. (305 mm) or less; and
  - (e) ABS or PVC plastic pipe is supported
    - (i) at intervals not exceeding 4 ft (1.2 m),
    - (ii) at the ends of *branches*,
    - (iii) at changes of direction or elevation, and
    - (iv) if the pipe is a *fixture drain* that is more than 3 ft (915 mm) in length, as close as possible to the *trap*.
- (3) Where PVC or ABS plastic pipe is installed
- (a) the pipe shall be aligned without added strain on the piping,
  - (b) the pipe shall not be bent or pulled into position after being welded, and
  - (c) hangers shall not compress, cut or abrade the pipe.
- (4) Where hangers are used to support *nominally horizontal* piping they shall be
- (a) metal rods of at least ¾ in. (10 mm) diameter for pipe over 4 in. (102 mm) in diameter, and
  - (b) solid or perforated metal strap hangers for pipe 4 in. (102 mm) or less in diameter.
- (5) Where a hanger is attached to concrete or masonry it shall be fastened by metal or expansion-type plugs that are inserted or built into the concrete or masonry.

**7.3.5.6. *Nominally horizontal* piping that is underground shall be supported on a base that is firm and continuous under the whole of the pipe.**

**Support for underground horizontal piping**

See Subsection 7.3.6. for additional protection required for underground pipes. Permitted installations are shown in Fig. 26(a); the methods of support shown in Fig. 26(b) are not permitted because the base does not provide firm and continuous support for the pipe. See Fig. 26, p. 40.

**7.3.5.7. Where a *vent pipe* terminates above the surface of a roof it shall be supported or braced to prevent misalignment.**

**Support of vent pipe above roof**

See Article 7.5.4.4. for location of vent pipe terminals.



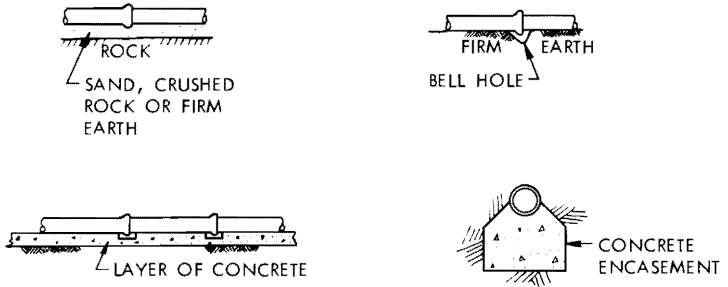

(a) Permitted

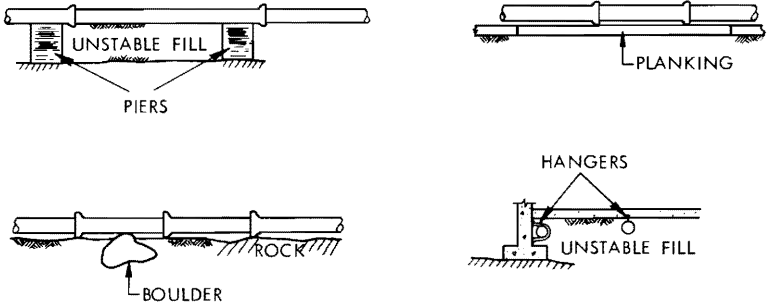

(b) Not permitted

Figure 26 Support for underground piping

### SUBSECTION 7.3.6. PROTECTION OF PIPING

#### Backfill

**7.3.6.1.** Where piping is installed underground the backfill shall be carefully placed and tamped to a height of 12 in. (305 mm) over the top of the pipe and shall be free of stones, boulders, cinders and frozen earth.

Stronger pipes may be required in deep fill or under driveways, parking lots, etc., and compaction for the full depth of the trench may be necessary. See Fig. 27.

#### Protection of non-metallic pipes

**7.3.6.2.** Where asbestos-cement drainage pipe, vitrified clay pipe, or bituminous fibre pipe is located less than 2 ft (610 mm) below a basement floor and the floor is constructed of other than 3 in. (76 mm) or more of concrete, the pipe shall be protected by a 3-in. (76 mm) layer of concrete installed above the pipe.

See Fig. 28.

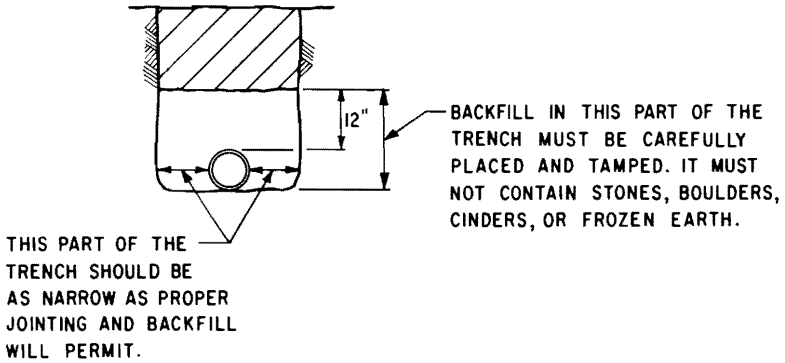
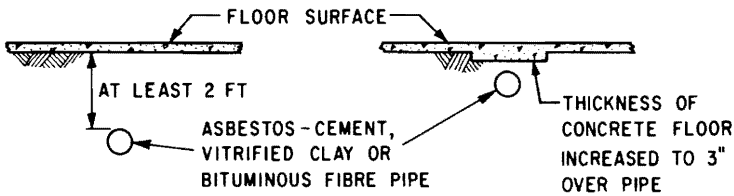
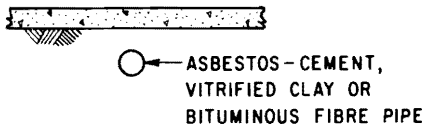

Figure 27 Backfilling of pipe trench



(a) Concrete floors less than 3" thick



(b) Concrete floor 3" or more in thickness (no protection required)

Figure 28 Protection of underground non-metallic pipes

7.3.6.3. Where piping passes through or under a wall it shall be installed so that the wall does not bear on the pipe.

Isolation from loads

7.3.6.4.(1) Where piping may be exposed to freezing conditions it shall be protected from frost.

Protection from frost

(2) Where a vent pipe that terminates above the surface of a roof is in danger of closure by frost it shall be insulated.

See Article 7.5.4.4. for location of vent pipe terminals.

7.3.6.5. Every fixture outlet pipe, trap, or fixture drain that is subject to damage shall be protected against damage to a height not less than 12 in. (305 mm) above the floor.

Protection against damage

**Protection of leaders in traffic ways** 7.3.6.6. Where a *leader* is exposed to possible damage in a lane or other traffic way, it shall be constructed of cast-iron pipe to a height of 5 ft (1.5 m) above finished ground level.

### SUBSECTION 7.3.7. TESTING OF DRAINAGE AND VENTING SYSTEMS

See Subsection 7.1.5. for additional requirements for inspection and testing.

7.3.7.1.(1) After a section of a *drainage system* or a *venting system* has been roughed in and before any *fixture* is installed, a water or an air test shall be conducted to the satisfaction of the *authority having jurisdiction*.

(2) After every *fixture* is installed and before any part of a *drainage system* or *venting system* is placed in operation the *authority having jurisdiction* may require a smoke test to each section of the system.

(3) Where required by the *authority having jurisdiction* a ball test shall be made to any pipe in a *drainage system*.

**Tests of drainage system** 7.3.7.2.(1) Every pipe in a *drainage system*, except an external *leader* or *fixture outlet pipe*, shall be capable of withstanding, without leakage, a water test, air test or smoke test.

(2) Every pipe in a *drainage system* shall be capable of meeting a ball test.

**Tests of venting system** 7.3.7.3. Every *venting system* shall be capable of withstanding, without leakage, a water test, air test or smoke test.

**Water test** 7.3.7.4.(1) Where a water test is made it shall be applied to

- (a) the system as a whole, or
- (b) sections of the system, each of which is at least 10 ft (3 m) high and includes at least 5 ft (1.5 m) of the section below.

(2) In making a water test

- (a) every opening except the highest shall be tightly closed with a testing plug or a screw cap, and
- (b) the system or the section shall be kept filled with water for 15 min.

**Air test** 7.3.7.5.(1) Where an air test is made

- (a) every opening in the system shall be closed,
- (b) air shall be forced into the system until a pressure of 5 psi (10 in. (254 mm) of mercury column), is created, and
- (c) this pressure shall be maintained, without the addition of more air for 30 min.

**Smoke test** 7.3.7.6.(1) Where a smoke test is made

- (a) every *trap* shall be filled with water,
- (b) smoke from one or more smoke machines shall be forced into the system,
- (c) when the smoke appears from all roof terminals they shall be closed, and

- (d) a pressure equivalent to a 1-in. (25 mm) water column shall be built up and maintained for 30 min.

7.3.7.7.(1) Where a ball test is made a hard ball that is sufficiently dense that it will not float shall be rolled through the pipe. **Ball test**

- (2) The diameter of the ball shall be

- (a) 2 in. (51 mm) where the *diameter* of the pipe is 3 in. (76 mm) or more, or  
 (b) 1 in. (25 mm) where the *diameter* of the pipe is less than 3 in. (76 mm).

## SUBSECTION 7.3.8. TESTING OF POTABLE WATER SYSTEM

See Subsection 7.1.5. for additional requirements concerning inspection and testing.

7.3.8.1.(1) After a section of a *potable water system* has been completed and before it is placed in operation, a water test shall be conducted to the satisfaction of the *authority having jurisdiction* except that an air test may be used in freezing conditions. **Application of tests**

- (2) A test may be applied to each section of the system or to the system as a whole.

7.3.8.2.(1) Every *potable water system* shall be capable of **Tests of water system**

- (a) withstanding without leakage a water pressure that is at least equal to the maximum pressure to which it may be subject in service, or  
 (b) withstanding for at least 2 hr without a drop in pressure an air pressure that is at least equal to 100 psi (690 kN/m<sup>2</sup>).

7.3.8.3.(1) Where a water test is made, all air shall be expelled from the system before *fixture* control valves or faucets are closed. **Water test**

- (2) *Potable water* shall be used to test a *potable water system*.

## SECTION 7.4 DRAINAGE SYSTEMS

### SUBSECTION 7.4.1. APPLICATION

7.4.1.1. This section applies to a *sanitary drainage system* or a *storm drainage system*.

### SUBSECTION 7.4.2. CONNECTION OF DRAINAGE SYSTEMS

7.4.2.1. Every *sanitary drainage system* shall be connected to a public *sanitary sewer* or *combined sewer*, or a *private sewage disposal system*. **Sanitary drainage system**

7.4.2.2.(1) Every *storm drainage system* shall be connected to one of the following: a *combined building drain*, a *combined building sewer*, a *public storm sewer*, a *public combined sewer*, or as designated by the *authority having jurisdiction*. **Storm drainage system**

(2) Every overflow from rainwater tanks shall be connected to a *storm drainage system* where such a system is installed.

(3) Where an overflow from a rainwater tank is connected to a *sanitary drainage system* a backwater valve shall be installed on the overflow pipe.

### SUBSECTION 7.4.3. DISPOSAL OF SUBSOIL DRAINAGE

Disposal of  
subsoil  
drainage

7.4.3.1. Subsoil drainage shall be disposed of as directed by the *authority having jurisdiction*.

See Article 7.4.8.6. for connection of subsoil drainage to a drainage system.

### SUBSECTION 7.4.4. CONNECTION OF FIXTURES

Connection  
to sanitary  
drainage  
system

7.4.4.1.(1) Every *fixture* shall be connected to a *sanitary drainage system* except that

- (a) a floor drain may be connected to a *storm drainage system* provided
  - (i) there is no *sanitary drainage system*,
  - (ii) it is located where it can receive only *clear-water waste* or *storm water*, and
  - (iii) the installation is *approved*,
- (b) *fixtures* that discharge only *clear-water waste*, other than a floor drain, may be connected to a *storm drainage system* or drained onto a roof,
- (c) every outlet from a relief valve on a *water system* shall be
  - (i) terminated above a receptacle that drains to outside air, or
  - (ii) turned downward and terminated within 1 ft (305 mm) of a floor that slopes to a floor drain, and
- (d) *fixtures* that have a hydraulic load of not more than one and one-half *fixture units* may be connected to a *loop vent*, *circuit vent*, *relief vent*, *yoke vent*, or *vent stack* provided
  - (i) no other *fixture* is drained to the *vent pipe*, and
  - (ii) the *fixture* that is connected to the *vent pipe* is in the same *storey* as the *fixtures* that are served by the *vent pipe*.

See Sentence 7.6.12.(5) for other requirements for outlets from relief valves.

Where fixtures are connected to vent pipes as shown in Fig. 29, the portion of the vent pipe serving as a fixture drain must be sized as a vent pipe in accordance with Subsection 7.5.5. for the particular vent pipe involved. For example, Article 7.5.5.7. specifies a minimum diameter of 2 in. for circuit, loop and relief vents. See Fig. 60, p. 80 and Fig. 61, p. 81, for examples of circuit and loop venting.

(2) No *waste pipe* or *branch* shall be connected to a horizontal *offset* closer than 5 ft (1.5 m) downstream from the base of the upper vertical section of the stack where such upper vertical section

- (a) receives a discharge of 30 or more *fixture units*, or
- (b) serves as a *soil-or-waste stack* for *fixtures* in two or more *storeys*.

See Fig. 30, p. 46.

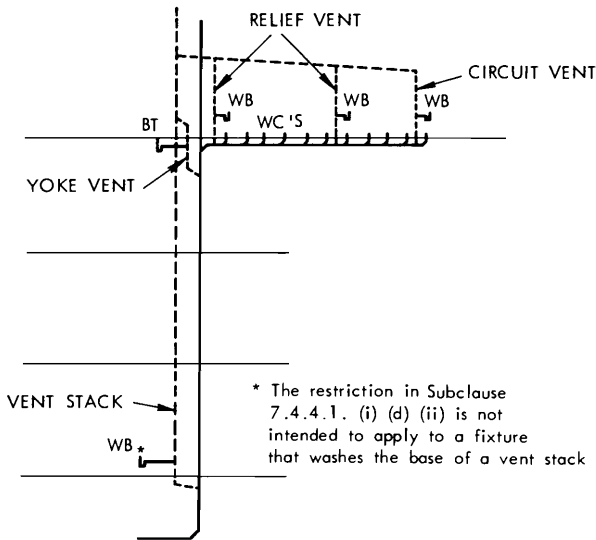

Figure 29 Fixture connections to vent pipes

Good practice dictates that connections of waste pipes to branches or building drains should be similarly restricted.

**(3) No other fixture shall be connected to a lead bend or stub that serves a water closet.**

**7.4.4.2.(1) Where one of the following fixtures is connected to a drainage system it shall be indirectly connected:**

**Indirect connections**

- (a) device for storage, preparation or processing of food or drink, including a refrigerator or icebox,
- (b) device or appliance that uses water as a cooling or heating medium,
- (c) drip pipe from a food receptacle,
- (d) water operated device,
- (e) sterilizer or water still,
- (f) water treatment device,
- (g) drain or overflow from a water system,
- (h) an overflow from a tank or vat in which a water supply inlet is protected according to Sentence 7.6.2.3.(3), or
- (i) a pressure, temperature or other relief valve that is installed in a water system.

**(2) Drinking fountains may be indirectly connected.**

See Clause 7.4.8.1.(1)(c) for trapping requirements for indirectly connected fixtures.

See Sentence 7.4.9.6.(6) for cleanouts on drip pipes for food receptacles.

See Sentences 7.4.4.1.(1) and 7.6.1.12.(5) for additional requirements for relief valve outlet terminals.

**Making indirect connections**

**7.4.4.3.(1)** Except as provided by Sentences (2) and (3), where a fixture is indirectly connected the connection shall be made by terminating the fixture drain above the flood level rim of a directly connected fixture to form an air break.

(2) Two or more fixture drains that serve outlets from a single fixture that is listed in Sentence 7.4.4.2.(1) may be directly connected to a branch that

(a) has a diameter of at least 1¼ in. (32 mm), and

(b) is terminated above the flood level rim of a directly connected fixture to form an air break.

(3) Two or more fixture drains from fixtures that are listed in Sentence 7.4.4.2.(1) may be directly connected to a pipe that

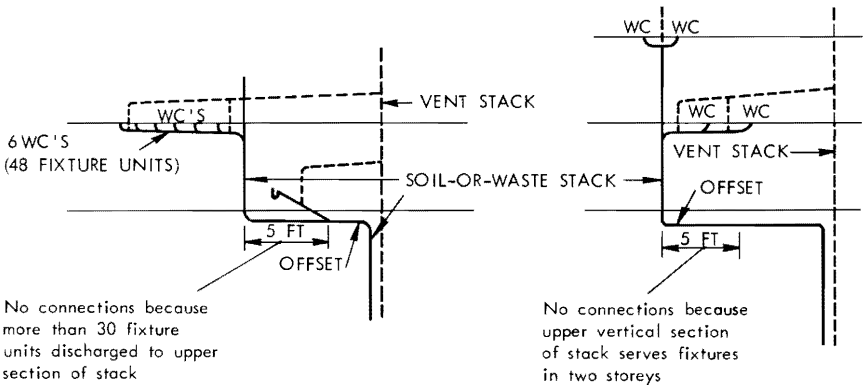

No connections because more than 30 fixture units discharged to upper section of stack

No connections because upper vertical section of stack serves fixtures in two storeys

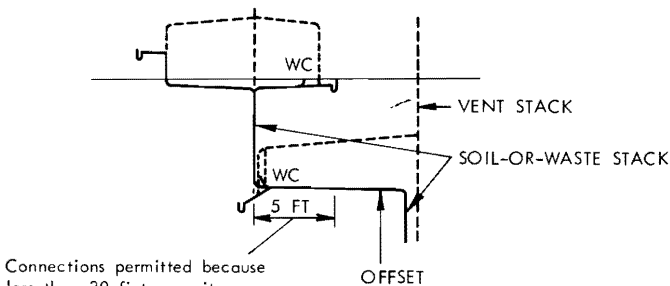

Connections permitted because less than 30 fixture units discharged to upper vertical section of the stack, and upper section of the stack serves fixtures in only one storey

**Figure 30** Connections to horizontal offsets in soil-or-waste stacks

- (a) is terminated to form an air break above the flood level rim of a fixture that is directly connected to a storm drainage system, and
- (b) is extended through the roof when fixtures that are on three or more storeys are connected to it.

See Fig. 31.

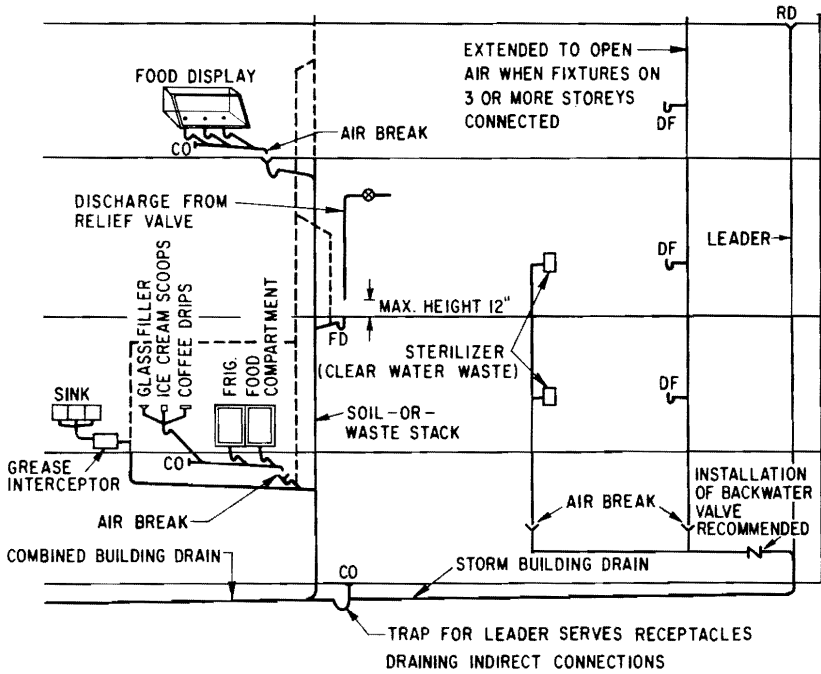

Figure 31 Indirect connections

- (4) The size of the air break shall at least equal the size of the fixture drain, branch or pipe that terminates above the directly connected fixture and it shall not be less than 1 in. (25 mm).

See Fig. 32, p. 48.

**SUBSECTION 7.4.5. LOCATION OF FIXTURES**

7.4.5.1. Plumbing fixtures shall be provided for various occupancies as required by the National Building Code of Canada 1970.

See Appendixes B and D for required plumbing facilities.

7.4.5.2. Every fixture shall be located where it is readily accessible for cleaning.

Accessibility

7.4.5.3. Every water closet or urinal shall be located in a room that is lighted and ventilated according to Subsections 3.6.2. and 3.6.3. of Part 3 of the National Building Code of Canada 1970.

Lighting and ventilation



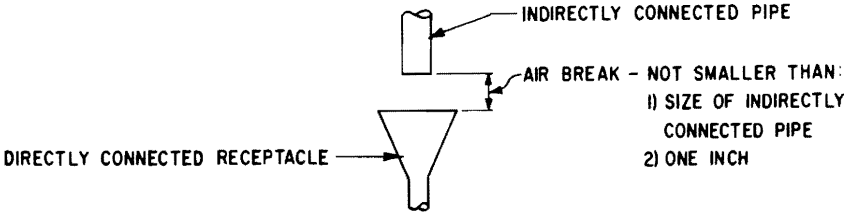

Figure 32 Air break

- Flush valve or tank** 7.4.5.4. Every direct flush valve or a flush tank shall be located where it is readily accessible for repair.
- Garbage grinder** 7.4.5.5. Garbage grinders shall not be located upstream of an *interceptor*. It is also recommended that potato peelers not be drained to interceptors.

**SUBSECTION 7.4.6. INSTALLATION OF FIXTURES**

- Water closets** 7.4.6.1.(1) Every floor-mounted water-closet bowl shall be securely attached to the floor by means of a flange.  
 (2) Every wall-mounted water-closet bowl shall be supported so that no strain is transmitted to the piping.
- 7.4.6.2. When a water closet is installed in a public washroom it shall be provided with a seat of the open front type.
- Stall urinal** 7.4.6.3. Every stall urinal shall be installed so that water from the urinal cannot run onto the walls or floor beneath the *fixture*. Walls and floors within 3 ft (915 mm) of the urinal shall be of an impervious material.
- Flushing device** 7.4.6.4.(1) Every flushing device that serves a water closet or one or more urinals shall have sufficient capacity and be adjusted to deliver at each operation a volume of water that will thoroughly flush the *fixture* or *fixtures* that it serves.  
 (2) Where a manually operated flushing device is installed it shall serve only one *fixture*.

**SUBSECTION 7.4.7. TREATMENT OF HARMFUL SEWAGE AND WASTES**

- Sewage treatment** 7.4.7.1.(1) Where a *fixture* discharges *sewage* that in the opinion of the authority having jurisdiction may damage or impair
  - (a) the *sanitary drainage system*, or
  - (b) the functioning of a public or private *sewage disposal system*,
 provision shall be made for treatment of the *sewage* before it is discharged to the *sanitary drainage system*.
- Cooling of hot wastes or sewage** 7.4.7.2. Where a *fixture* discharges *sewage* or *clear-water waste* that is at a temperature in excess of 170 deg. F. (77°C), provision shall be made for cooling of the waste to less than 170 deg. F. (77°C) before it is discharged to the *drainage system*.
- Interceptors for oil, gasoline or grease** 7.4.7.3.(1) Where a *fixture* discharges oil or gasoline an oil *interceptor* shall be installed.

(2) Where a *fixture discharges sewage* that includes grease is located in a public kitchen or restaurant or in an institution, a grease *interceptor* shall be installed on the *fixture drain* where required by the *authority having jurisdiction*.

(3) Where a *fixture discharges sand, grit or similar materials* an appropriate *interceptor* shall be installed.

(4) Every *interceptor* shall have sufficient capacity to perform the service for which it is provided.

(5) Every *interceptor* shall be located where it is readily accessible for cleaning.

See Article 7.5.3.2. for venting requirements for oil interceptors.

### SUBSECTION 7.4.8. TRAPS

7.4.8.1.(1) Every *fixture outlet pipe* of a *fixture* that is *directly or indirectly connected* shall be provided with a *trap* except that

Traps for fixtures

- (a) one *trap* may serve all the trays or compartments of a two- or three-compartment sink or a pair of laundry trays if
  - (i) the waste openings are at the same level,
  - (ii) the *developed length* of the *fixture outlet pipe* from the *trap* to the waste opening of the farthest compartment or tray does not exceed 36 in. (915 mm), and
  - (iii) the part of the *fixture outlet pipe* that is common to two or three compartments of a sink is one size larger than the largest waste opening that it serves,

See Fig. 33.

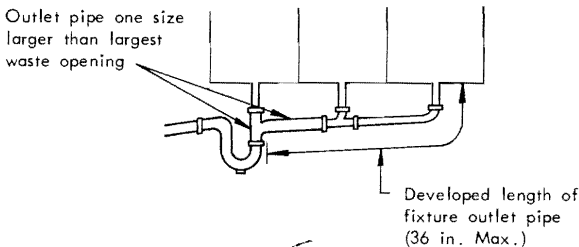

Figure 33 Trapping of compartment sink

- (b) one *trap* may serve a group of floor drains, a group of washing machines, or a group of laboratory sinks if the *fixtures*
  - (i) are in the same room, and
  - (ii) are not located where they can receive food or other organic matter,
- (c) a *trap* is not required for an *indirectly connected fixture*, other than a drinking fountain, that can discharge only *clear-water waste*,

See Articles 7.4.4.2. and 7.4.4.3. for indirect connections,

and

- (d) where an *interceptor* is installed to serve a *fixture* and has an effective water seal of at least 1½ in. (38 mm), it may serve as a *trap*.

Interceptor as trap

An interceptor that replaces a trap must be vented in the same way as the trap it replaces. Where an interceptor (other than an oil interceptor) serves a group of fixtures (requiring more than one trap), each fixture must be properly trapped and vented. See Article 7.5.3.2. for venting of oil interceptors.

(2) **Open traps, acid traps or any trap that may overflow shall not be permitted in a crawl space or any other unfrequented area.**

Location  
of trap or  
interceptor

**7.4.8.2. Every trap and every interceptor that serves as a trap shall be located as close as is practicable to the fixture it serves, and in no case shall the developed length of the fixture outlet pipe be more than 36 in. (915 mm).**

See Fig. 34.

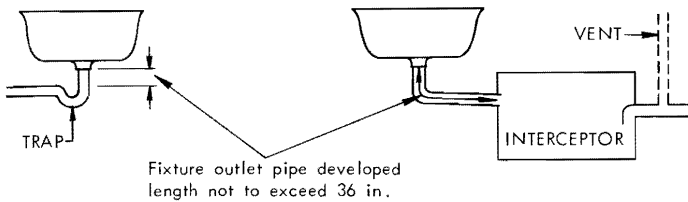

Figure 34 Location of trap or interceptor

Size of trap

**7.4.8.3.(1) The size of a trap that serves a fixture shall not be less than the size of the fixture outlet pipe.**

**(2) The size of a trap that serves a fixture shall not be less than the size set forth in Table 7.4.8.A.**

Table 7.4.8.A  
Forming Part of Sentence 7.4.8.3.(2)

Fixture	Min. Dia. of Trap, in.	Minimum Hydraulic Load, fixture units
Autopsy table	1½	2
Bathroom group		
(a) with flush tank	—	8
(b) with flush valve	—	10
Bathtub	1½	1½
Bath: foot, sitz or slab	1½	1½
Beer cabinet	1½	1½
Bidet	1¼	1
Clothes washer	1½	2
Dental unit or cuspidor	1¼	1
Dishwasher		1½ { no load when connected to garbage grinder
(a) domestic type	1½	
(b) commercial type	2	
Drinking fountain	1¼	1
Floor drain	2	3 with 2 in. trap 5 with 3 in. trap
Garbage grinder, commercial type	2	3
Icebox	1¼	1

Cont'd next page

Table 7.4.8.A (Cont'd)

<i>Fixture</i>	<b>Min. Dia. of Trap, in.</b>	<b>Minimum Hydraulic Load, <i>fixture units</i></b>
Laundry tray		1½ } Same load with separate traps or common trap
(a) 1 or 2 compartments	1½	
(b) 3 compartments	1½	2
Potato peeler	2	3
Shower drain		
(a) from 1 head	1½	1½
(b) from 2 or 3 heads	2	3
(c) from 4 to 6 heads	3	6
Sink		
(a) siphon trap type	3	5
(b) trap standard service	2	3
(c) with P-trap		
(i) butler, bar, rinse, single compartment kitchen sink or single compartment of combination sink	1½	1½
(ii) 1 and 2 compart- ment kitchen sinks or single compart- ment of combination sink—with garbage grinder	1½	1½
(iii) 3 compartment sink — common trap	2	2
(iv) 2 or 3 compartment sink with garbage grinder — common trap	2	3
(v) dishwasher, pot or scullery	2	4
(vi) P-trap service	2	3
(vii) surgeons or surgeons scrub	1½	1½
Urinal		
(a) pedestal, siphon-jet or blowout type	2	4
(b) stall, washout type	2	2
(c) wall, lip type		
(i) washout type	1½	1½
(ii) other types	2	3
Washbasin		
(a) barber or beauty parlor	1½	1½
(b) dental	1¼	1
(c) domestic type	1¼	} 1 with 1¼ in. trap } 1½ with 1½ in. trap according to Table 7.4.11.A.
(d) multiple or circular	1½	
Water closet		
(a) with flush tank	3	6
(b) with flush valve	3	8
<b>Column 1</b>	<b>Column 2</b>	<b>Column 3</b>

**Trap seal**    **7.4.8.4. Provision shall be made for maintaining the trap seal of a floor drain by the use of trap seal primer, by using the drain as a receptacle for an indirectly connected drinking fountain, or by equally effective means.**

Periodic manual replenishment of the water in a trap is considered to be an equally effective means of maintaining the trap seal in floor drains in residences.

See Fig. 35.

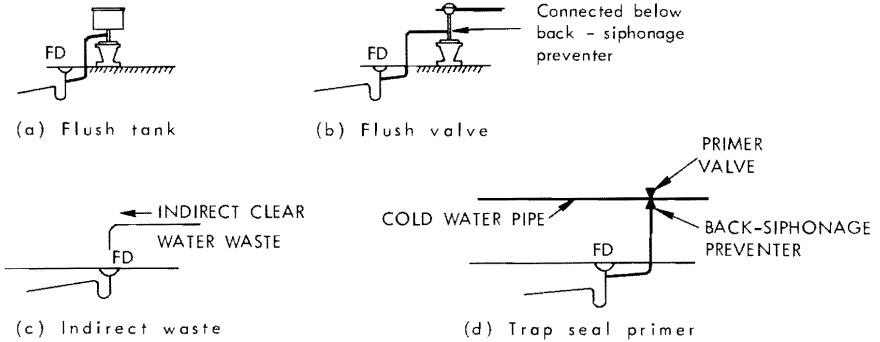

Figure 35    Maintaining trap seals

**Traps for storm drainage system**

**7.4.8.5.(1) Where a storm drainage system is connected to a combined building drain or combined building sewer a trap shall be installed between any opening from the system and the drain or sewer, except that no trap is required if the opening is the upper end of a leader that terminates**

- (a) at a roof that is used only for weather protection, and
- (b) at least 3 ft (915 mm) above or 12 ft (3.7 m) in any direction from an air inlet, a window or a door.

See Fig. 36.

The clearance requirements for untrapped leaders are similar to those for vent pipe terminals (see Fig. 68, p. 87).

**Traps for subsoil drains**

**7.4.8.6.(1) Every subsoil drainage pipe shall be provided with a trap and cleanout when connected to a plumbing system.**

**(2) Where a subsoil drainage pipe is connected to a storm drainage system that is connected to a combined building drain or sewer, the connection shall be made on the upstream side of a trap or a trapped sump.**

This Code does not regulate the installation of subsoil drainage pipes but does regulate the connection of such pipes to the plumbing system. The intent of this Article is to place a trap between the subsoil drainage pipe and the sanitary drainage system. The cleanout must be installed in accordance with Sentence 7.4.9.6.(8). A trap or a sump may be provided specifically for the subsoil drains or advantage may be taken of the trap of a floor drain or storm water sump as shown in Fig. 37. Also see Fig. 40, p. 56, for examples of cleanouts and traps for building drains.

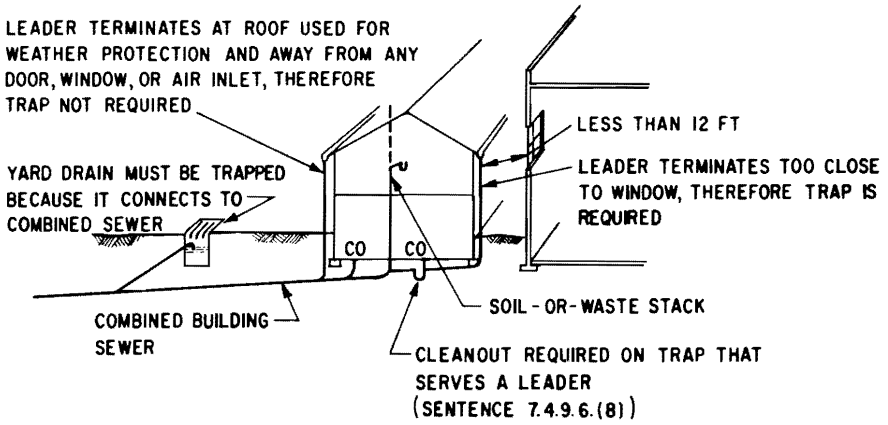
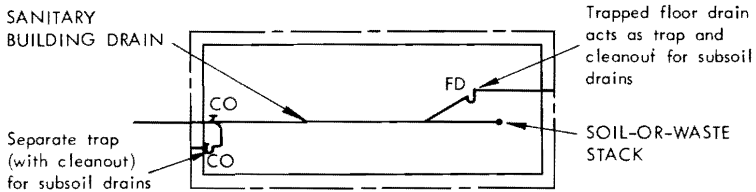
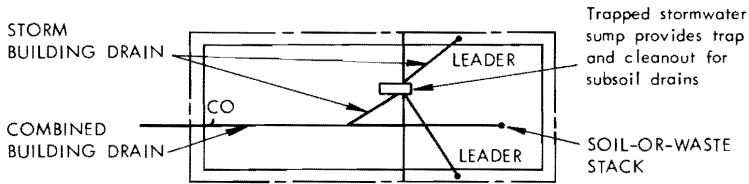

Figure 36 Traps for storm drainage system



(a) Connections to sanitary drainage system



(b) Connections to combined building drains

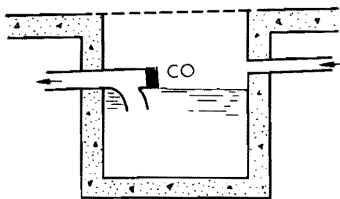

(c) Trapped sump

Figure 37 Subsoil drainage connections

- Location of building trap** 7.4.8.7.(1) Where a *building-trap* is installed it shall be located
- (a) inside the *building* and as close as is practicable to the wall through which the *building drain* leaves the *building*, or
  - (b) outside the *building* in an accessible manhole.

#### SUBSECTION 7.4.9. ARRANGEMENT OF DRAINAGE PIPING

- Location of piping** 7.4.9.1.(1) Piping shall not be located over nonpressure *potable* water tanks, over manholes in pressure *potable* water tanks or over food-handling equipment.
- (2) Rainwater *leaders* shall not be used for *soil-or-waste pipes* and *soil-or-waste pipes* shall not be used for rainwater *leaders*.
- Unused open ends** 7.4.9.2. There shall be no unused open ends in a *drainage system*.
- Lead caulked pipe** 7.4.9.3. A length of hub and spigot pipe and pipe fittings in a *plumbing system* shall be installed with the hub at the upstream end.
- Sumps or tanks** 7.4.9.4.(1) Piping that is too low to drain into a *building sewer* by gravity shall be drained to a *sump* or receiving tank.
- (2) Where the *sump* or tank receives *sewage* it shall be water- and air-tight and shall be vented in accordance with Section 7.5.
- (3) Equipment such as a pump or ejector that can lift the contents of the *sump* or tank and discharge it into the *building sewer* shall be installed.
- (4) Where the equipment does not operate automatically the *size* of the *sump* shall be sufficient to hold at least a 24-hr accumulation of liquid.
- (5) Where there is a *building-trap*, the discharge pipe from the equipment shall be connected to the *building drain* downstream of the *trap*.
- (6) The discharge pipe from every *sewage sump* shall be equipped with a shut-off valve, a check valve and a union.

See Fig. 38.

In most installations controls will be installed in conjunction with a float to automatically empty the sump. If such controls are not provided the capacity of the sump should equal the maximum inflow to the sump that is expected to occur during any 24-hr period.

- Protection from backflow** 7.4.9.5.(1) Where a *building drain* may be subject to surcharge a gate valve or a backwater valve shall be installed on the *fixture drain* of a *fixture*, other than a floor drain, that
- (a) is below the level of the adjoining street, and
  - (b) drains by gravity into the *building drain*.
- (2) Where a floor drain is connected to a *building drain* that may be subject to *backflow*
- (a) a backwater valve shall be installed on the *fixture drain* or upstream of the *trap*,
  - (b) a gate valve shall be installed on the *fixture drain* of the floor drain, or





- (c) a screw cap shall be installed on the upstream side of the trap of the floor drain.

See Fig. 39, p. 55.

These requirements are intended to apply when in the opinion of the authority having jurisdiction there is danger of backup from a public sewer. Where all the fixtures served by a branch are located below street grade and in the same room a gate valve or a backwater valve may be installed on the branch rather than one on each fixture drain.

- (3) Where a sanitary building drain or sewer or a combined building drain or sewer may be subject to surcharge a subsoil drainage pipe that drains into it shall be connected in such a manner that sewage cannot back up into the subsoil drainage pipe.

#### Cleanouts

- 7.4.9.6.(1) Except as provided in Sentence (2), a building drain shall be provided with a cleanout that is installed at the upstream side of the wall through which the drain leaves the building, and where a building-trap is installed inside the building the cleanout shall be between the trap and the wall.

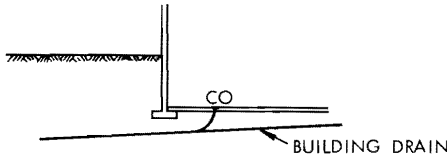

(a) No building trap

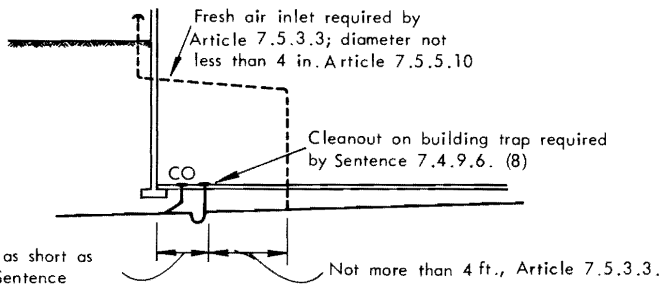

This distance as short as practicable (Sentence 7.4.8.7. (1) )

(b) Building trap inside building

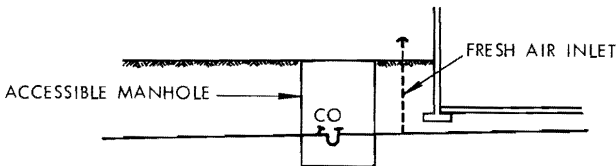

(c) Building trap outside building

Figure 40 Cleanouts for building drains

(2) Where a *building-trap* is installed outside a *building* a *cleanout* shall be installed in the manhole on the downstream side of the trap.

See Fig. 40.

(3) Where there is a change of direction of more than 45 deg. in a *building drain* a *cleanout* shall be installed.

(4) *Cleanouts* shall be installed in a *nominally horizontal branch* or a *building drain* at intervals that will ensure that the distance between *cleanouts* does not exceed

- (a) 100 ft (30.5 m) where the *diameter* of the pipe exceeds 4 in. (102 mm), or
- (b) 50 ft (15.2 m) where the *diameter* of the pipe is equal to or less than 4 in. (102 mm).

See Fig. 41.

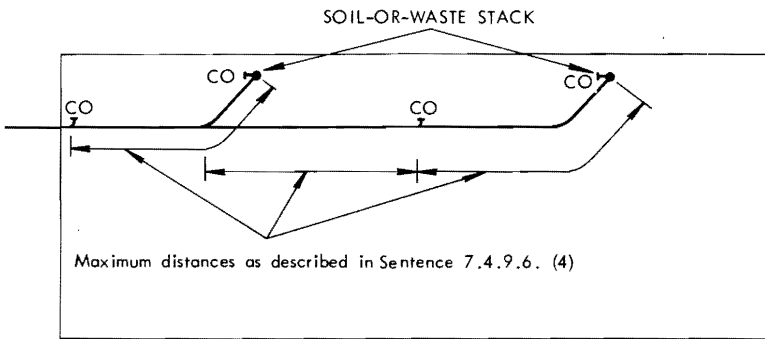

Figure 41 Spacing of cleanouts

(5) Every *soil-or-waste stack* shall be provided with a *cleanout* that is installed at the base of the stack except that the *cleanout* may be omitted where there is a *cleanout* of a type in which the *cleanout* entrance is at right angles to the *building drain* within 10 ft (3 m) of the stack.

The cleanouts at the base of the stacks shown in Figure 41 may be omitted if there is a cleanout in the building drain within 10 ft of the stack and the cleanout is of the type which permits rodding in both directions. See Fig. 43(a) and (b), p. 58.

(6) Where there is a change in direction in a drip pipe from a food receptacle a *cleanout* shall be installed.

See Fig. 42, p. 58.

(7) *Cleanouts* shall be installed on the *fixture drain* of a sink at intervals that will ensure that no point of the *fixture drain* is more than 20 ft (6.1 m) from a *cleanout*.

Sentence 7.2.3.1.(2) requires that traps on all sinks be equipped with a cleanout plug or be removable for cleaning. Additional cleanouts are required where the length of the fixture drain exceeds 20 ft.

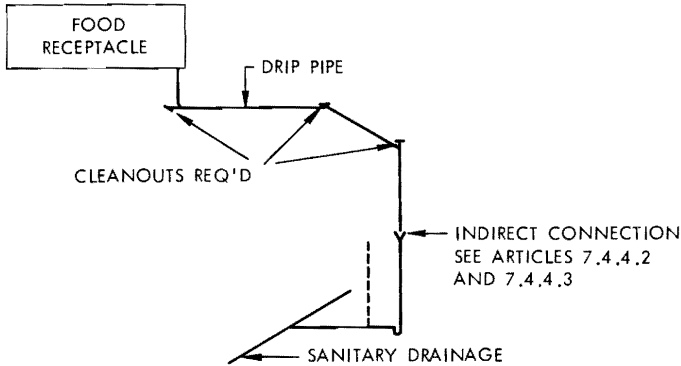

Figure 42 Cleanouts for food receptacle drip pipe

(8) A cleanout shall be installed at the upstream side of, and directly over, every building-trap or trap that serves a leader or subsoil drainage pipe.

For illustrations of required cleanouts see Fig. 36, p. 53, Fig. 37, p. 53, and Fig. 40, p. 56.

**Type of cleanout**

7.4.9.7.(1) Every cleanout shall be made with

- (a) a barrett-type fitting that has a bolted cover plate and gasket,
- (b) a fitting that has a threaded plug, or
- (c) a cleanout ferrule that is installed on a Y.

(2) Where the Y is extended it shall be extended without a change of direction of more than 45 deg.

See Fig. 24, p. 33, for cleanout ferrules. Types of cleanouts are shown in Fig. 43.

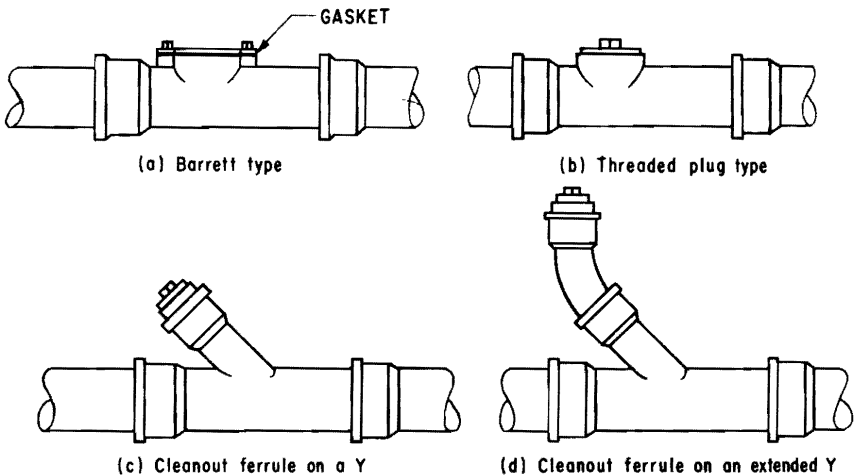

Figure 43 Types of cleanouts

7.4.9.8. Where the *size* of a pipe is less than 4 in. (102 mm) the *size* of a *cleanout* on the pipe shall be at least the same *size* as the pipe, and where the *size* of the pipe is 4 in. (102 mm) or more the *size* of the *cleanout* shall be at least 4 in. (102 mm).

Size of cleanout

7.4.9.9.(1) Every *cleanout* shall be so located that the opening is readily accessible and has sufficient clearance for effective rodding and cleaning.

Location of cleanout

(2) Manholes may be used as *cleanouts* in a *building sewer* or *building storm sewer* and where the *building sewer* or *building storm sewer* is of a diameter of 6 in. (152 mm) or larger,

- (a) the *developed length* from the outer face of the wall of the building to the manhole nearest to the outer face of the wall shall not exceed 100 ft (30.5 m),
- (b) the distance between successive manholes in the *building sewer* or *building storm sewer* shall not exceed 300 ft (91.5 m), and
- (c) there shall be no change in slope or direction of any section between manholes of a *building sewer* or *building storm sewer*.

**SUBSECTION 7.4.10. MINIMUM SLOPE OF DRAINAGE PIPES**

7.4.10.1.(1) Except as provided in Sentences (2) and (3), a pipe shall have a slope in the direction of flow of at least 1/8 in. per ft.

Minimum slope

(2) *Building sewers* may have slopes less than 1/8 in. per ft if they are designed so that the liquid velocity is at least 2 ft per sec.

(3) Every pipe that has a *diameter* of 3 in. (76 mm) or less, and every *fixture drain* shall have a slope in the direction of flow of at least 1/4 in. per ft.

Type of Pipe	Diameter, in.	Minimum Slope, in./ft
Fixture drains	any size	1/4
Drainage pipes	3 in. or less	1/4
Drainage pipes — (except building sewers)	over 3 in.	1/8
Building sewer — (no velocity limitation)	any size	1/8
Building sewer — (designed for minimum velocity of 2 ft/sec)	4	1/8
	5	3/32
	6	3/32
	8	1/16
	10	1/16
	12	1/32
	15	1/32

Figure 44 Minimum slopes of drainage pipes

Although slopes below 1/8 in. per foot are permitted, it is recommended that they be used only where necessary. Steeper slopes and higher velocities will help to keep pipes clean by moving heavier solids that might tend to clog the pipes.

### SUBSECTION 7.4.11. HYDRAULIC LOADS

Articles 7.4.11.1. to 7.4.11.6. describe how the total hydraulic load that is discharged to drainage pipes is to be determined. Articles 7.4.11.7 to 7.4.11.12. prescribe the maximum hydraulic loads that drainage pipes are permitted to carry. Subsection 7.4.12. specifies minimum sizes that apply regardless of the hydraulic loads on the pipe. A full description of the application of these Subsections to the calculation of pipe sizes follows Subsection 7.4.12., p. 67 to 74.

- Total load**     **7.4.11.1.(1) The hydraulic load on a pipe is the total load from**
- (a) every *fixture* that is connected to the system upstream of the pipe,
  - (b) every *fixture* for which provision is made for future connection upstream of the pipe, and
  - (c) all roofs and paved surfaces that drain into the system upstream of the pipe.

**Hydraulic load from fixtures**     **7.4.11.2. The hydraulic load from a *fixture* that is listed in Table 7.4.8.A. is the number of *fixture units* set forth in the Table.**

See Table 7.4.8.A., p. 50, which specifies both trap size and fixture unit loading.

**Hydraulic load from fixtures not in Table 7.4.8.A.**     **7.4.11.3. Except as provided in Article 7.4.11.4., the hydraulic load from a *fixture* that is not listed in Table 7.4.8.A. is the number of *fixture units* set forth in Table 7.4.11.A. for the *trap* of the size that serves the *fixture*.**

Table 7.4.11.A.

Forming Part of Article 7.4.11.3.

Size of Trap, in.	Hydraulic Load, <i>fixture units</i>
1¼ or less	1
1½	2
2	3
2½	4
3	5
4	6
Column 1	Column 2

**Hydraulic loads from fixtures with continuous flow**

**7.4.11.4.(1) Except as provided in Sentence (2), the hydraulic load from a *fixture* that produces a continuous or semi-continuous flow, such as a pump or an air-conditioning *fixture*, is two *fixture units* for each Canadian gallon per minute of flow.**

(2) Where a *fixture* that produces a continuous or semi-continuous flow drains to a *combined drain or sewer*, or to a *storm drain or sewer*, the hydraulic load from the *fixture* is 29 sq ft for each gallon per minute of flow.

7.4.11.5.(1) Except as provided in Sentence (2), the hydraulic load in square feet from a roof or paved surface is the maximum 15-minute rainfall specified in Appendix E, Rainfall Intensities, multiplied by the sum of:

Hydraulic load from roof or paved surface

- (a) the area in square feet of the horizontal projection of the surface that is drained, and
- (b) one-half the area in square feet of the largest adjacent vertical surface.

The “adjacent vertical surface” referred to here is any vertical surface that can drain to the gutter, leader, or drain that is under consideration.

(2) Where a proportional weir roof drain is installed, the hydraulic load in Sentence (1) may be reduced subject to the approval of the *authority having jurisdiction*.

A proportional weir holds back the peak flow resulting from a rainfall and allows the water to run off at a reduced rate. The reduction in flow depends on the characteristics of the weir that is installed; the manufacturer’s literature should be consulted for information about the hydraulic loads to be expected.

7.4.11.6.(1) Except as provided in Sentence 7.4.11.4.(2), where the hydraulic load is to be expressed in square feet, *fixture units* shall be converted as follows:

Conversion of fixture units to square feet

- (a) when the number of *fixture units* is 256 or fewer, the load is 1000 sq ft (93 m<sup>2</sup>), and
- (b) when the number of *fixture units* exceeds 256, the load is 3.9 sq ft (0.36 m<sup>2</sup>) for each *fixture unit*.

7.4.11.7.(1) The hydraulic load that is drained to every *soil-or-waste stack* that passes through 3 *storeys* or less or to an *offset* that is part of the stack, shall not exceed the number of *fixture units* that is set forth in column 2 of Table 7.4.11.B., according to the *diameter* of the stack.

Hydraulic load on stack

(2) The hydraulic load that is drained to every *soil-or-waste stack* that passes through more than 3 *storeys* or to an *offset* that is part of the stack, shall not exceed the number of *fixture units* set forth in column 3 of Table 7.4.11.B., according to the *diameter* of the stack, and the hydraulic load from *fixture drains* or *branches* that are connected to the stack in a single *storey* shall not exceed the number of *fixture units* set forth in column 4 of Table 7.4.11.B., according to the *diameter* of the stack.

7.4.11.8 The hydraulic load that is drained to a *branch* shall not exceed the number of *fixture units* set forth in Table 7.4.11.C. according to the *diameter* of the *branch*.

Hydraulic load on branch

**Table 7.4.11.B.**  
**Forming Part of Article 7.4.11.7.**

<i>Diameter of Stack, in.</i>	<i>Maximum Load on Soil-or-Waste Stack, fixture units</i>		
	<i>Maximum load on stack that passes through 3 storeys or less</i>	<i>Maximum load on stack that passes through more than 3 storeys</i>	<i>Maximum load to be drained to stack of more than 3 storeys from any 1 storey</i>
1¼	2	2	1
1½	5	8	2
2	10	24	6
2½	20	42	9
3	60	60	16
4	240	500	90
5	540	1100	200
6	960	1900	350
8	2200	3600	600
10	3800	5600	1000
12	6000	8600	1500
<b>Column 1</b>	<b>Column 2</b>	<b>Column 3</b>	<b>Column 4</b>

**Table 7.4.11.C.**  
**Forming Part of Article 7.4.11.8.**

<i>Diameter of Branch, in.</i>	<i>Maximum Load on Branch, fixture units</i>
1¼	1
1½	3
2	6
2½	12
3	27
4	180
5	390
6	700
8	1600
10	2500
12	3900
<b>Column 1</b>	<b>Column 2</b>

7.4.11.9. The hydraulic load that is drained to a sanitary building drain or a sanitary building sewer shall not exceed the number of fixture units set forth in Table 7.4.11.D. according to the diameter and slope of the drain or sewer.

Hydraulic load on sanitary building drain or sewer

Table 7.4.11.D.  
Forming Part of Article 7.4.11.9.

Diameter of Drain or Sewer, in.	Maximum Load on Drain or Sewer, fixture units			
	Slope of Drain, in./ft.			
	1/16	1/8	1/4	1/2
3	—	20	27	36
4	—	180	240	300
5	—	390	480	670
6	—	700	840	1300
8	1400	1600	2250	3370
10	2500	3000	4500	6500
12	3900	5400	8300	13000
15	7000	10400	16300	22500
Column 1	Column 2	Column 3	Column 4	Column 5

Column 2 of Table 7.4.11.D. applies only to building sewers because Article 7.4.10.1. requires that the slope of sanitary building drains be at least 1/8 in. per foot. The maximum load of 20 fixture units shown in Column 3 for a 3-in. pipe applies only to building sewers draining to a private sewage disposal system. Fig. 45 gives values for the maximum loads on sanitary sewers having low slopes as permitted by Subsection 7.4.10.

Diameter of Building Sewer, in.	Maximum Load on Sanitary Building Sewer, Fixture Units		
	Slope of Sewer, in./ft		
	1/32	1/16	3/32
5	—	—	380
6	—	—	600
8	—	1400	1500
10	—	2500	2700
12	2240	3900	4500
15	4800	7000	9300
Column 1	Column 2	Column 3	Column 4

Figure 45 Maximum loads on sanitary sewers having low slopes



Hydraulic load on horizontal storm pipe combined building drain or sewer

7.4.11.10.(1) The hydraulic load calculated in accordance with this Subsection that is drained to

- (a) a nominally horizontal pipe in a storm drainage system,
- (b) a combined building drain, or
- (c) a combined building sewer

shall not exceed the number of square feet set forth in Table 7.4.11.E.

Table 7.4.11.E.

Forming Part of Article 7.4.11.10.

Diameter of Pipe, Drain or Sewer, in.	Maximum Load on Pipe, Drain or Sewer, sq ft		
	Slope of Pipe, Drain or Sewer, in./ft		
	1/8	1/4	1/2
3	822	1160	1644
4	1880	2650	3760
5	3340	4720	6680
6	5350	7550	10700
8	11500	16300	23000
10	20700	29200	41400
12	33300	47000	66600
15	59400	84000	119000
Column 1	Column 2	Column 3	Column 4

Fig. 46 gives values for the maximum loads on storm building sewers or combined building sewers having low slopes as permitted by Subsection 7.4.10.

Diameter of Sewer, in.	Maximum Load on Storm or Combined Building Sewer, sq ft		
	Slope of Sewer, in./ft		
	1/32	1/16	3/32
5	—	—	2880
6	—	—	4650
8	—	8090	10000
10	—	14680	18100
12	17000	23800	29400
15	30700	43200	53200
Column 1	Column 2	Column 3	Column 4

Figure 46 Maximum loads on storm and combined building sewers having low slopes

7.4.11.11.(1) The hydraulic load calculated in accordance with this Subsection that is drained to

Hydraulic load on roof gutters

- a) a semi-circular roof gutter shall not exceed the number of square feet set forth in Table 7.4.11.F. for the appropriate *diameter* and slope of gutter, and
- b) a gutter that is not semi-circular shall not exceed the number of square feet set forth in Table 7.4.11.F. for the appropriate area and slope of gutter.

Table 7.4.11.F.

Forming Part of Article 7.4.11.11.

Diameter of Gutter, in.	Area of Gutter, sq in.	Maximum Load on Gutter, sq ft			
		Slope of Gutter, in./ft			
		1/16	1/8	1/4	1/2
3	3.53	170	240	340	480
4	6.28	360	510	720	1020
5	9.82	625	880	1250	1770
6	14.14	960	1360	1920	2770
7	19.24	1380	1950	2760	3900
8	25.13	1990	2800	3980	5600
10	39.27	3600	5100	7200	10000
Column 1	Column 2	Column 3	Column 4	Column 5	Column 6

7.4.11.12.(1) The hydraulic load calculated in accordance with this Subsection that is drained to

Hydraulic load on leaders

- (a) a circular *leader* shall not exceed the number of square feet set forth in Table 7.4.11.G. (Column 2), and
- (b) a *leader* that is not circular shall not exceed the number of square feet set forth in Table 7.4.11.G. (Column 4).

Table 7.4.11.G

Forming Part of Article 7.4.11.12.

Circular Leader		Non-Circular Leader	
Diameter of Leader, in.	Max. Load, sq ft	Area of Leader, sq in.	Max. Load sq ft
2	720	3.14	650
2½	1300	4.90	1170
3	2200	7.07	1980
4	4600	12.57	4140
5	8650	19.63	7785
6	13500	28.27	12150
8	29000	50.26	26100
Column 1	Column 2	Column 3	Column 4

## SUBSECTION 7.4.12. DIAMETER OF PIPES

- Minimum size** 7.4.12.1. A pipe shall not be smaller than the largest pipe that drains into it.
- Pipe serving water closet** 7.4.12.2. The *diameter* of every pipe that serves a water closet shall be at least 3 in. (76 mm).
- Pipe serving more than 2 water closets** 7.4.12.3 The *diameter* of every *branch, building drain or building sewer* that serves more than two water closets shall be at least 4 in (102 mm).
- Building sewer and drain** 7.4.12.4. The *diameter* of every *building sewer* and the *diameter* of every *building drain* connecting a *building sewer* to a *main vent* shall be at least 4 in. (102 mm), except that the *diameter* of a *building drain or building sewer* that drains to a *private sewage disposal system* may be 3 in. (76 mm) when not more than 27 *fixture units*, including not more than two water closets, are drained into it.
- Minimum diameter of stack** 7.4.12.5. The *diameter* of every *soil-or-waste stack* that serves more than six water closets shall be at least 4 in. (102 mm).
- Fixture outlet pipe** 7.4.12.6. The *diameter* of every *fixture outlet pipe* shall not be less than the *diameter* of the *fixture waste opening*.
- Fixture drain** 7.4.12.7. The *diameter* of every *fixture drain* shall not be less than the *size* of the *trap* that serves the *fixture*.
- Main vent** 7.4.12.8. The *diameter* of every vertical *soil-or-waste pipe*, including a *soil-or-waste stack*, that is part of a *main vent* shall be at least 3 in. (76 mm) and where the *soil-or-waste stack* extends through six or more *storeys* the *diameter* shall be at least 4 in. (102 mm).

See Fig. 47.

Drainage Pipe	Minimum Size
Any drainage pipe	Size of largest upstream pipe
Any fixture outlet pipe	Size of fixture waste opening
Any fixture drain	Size of trap
Any pipe that serves 1 or 2 WC's	3 inches
Branch or building drain that serves 3 or more WC's	4 inches
Building sewer or building drain connecting to main vent	
(a) draining to private disposal system and not draining more than 27 fixture units or more than 2 WC's	3 inches
(b) all others	4 inches
Soil-or-waste stack that is part of main vent	
(a) if it passes through less than 6 storeys	3 inches
(b) if it passes through 6 or more storeys	4 inches

Figure 47 Minimum sizes of drainage pipes

Where a soil-or-waste pipe also serves as a vent pipe, the minimum size may be determined by venting requirements as contained in Section 7.5. Examples are shown in Fig. 48.

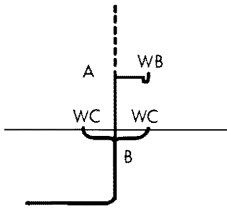

(a) Stack venting

According to Table 7.4.11.B, section AB of the soil-or-waste stack need only be  $1\frac{1}{4}$  in. in diameter, however the two water closets are stack vented and Clause 7.5.1.7. (1). (b) requires that the soil-or-waste stack continue full size to the topmost fixture, hence its diameter must be 3 in.

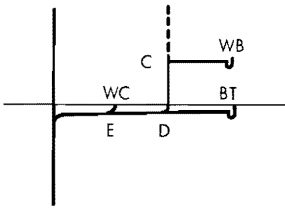

(b) Wet venting

According to Table 7.4.11.C, the branch DE need only be  $1\frac{1}{2}$  in. in diameter and according to Table 7.4.8.A the fixture drain CD need only be  $1\frac{1}{4}$  in. in diameter. However, the bathtub and water closet are wet vented and Sub clause 7.5.1.6 (1) (e) (iii) requires that CDE be 2 in. in diameter because the fixture drain of the water closet is 3 in.

**Figure 48** Sizing of soil-or-waste pipes serving as vents

## DETERMINATION OF HYDRAULIC LOADS AND DRAINAGE PIPE SIZES

### HYDRAULIC LOADS

The hydraulic load that is imposed by a fixture is represented by a factor called a fixture unit. Fixture units are dimensionless and take into account the rate of discharge, time of discharge and frequency of discharge of the fixture.

Confusion often arises when attempts are made to convert fixture units to gallons per minute because there is no straightforward relationship between the two. The proportion of the total number of fixtures that can be expected to discharge simultaneously in a large system is smaller than in a small system. For example, doubling the number of fixtures in a system will not double the peak flow that the system must carry, although of course the flow will be increased somewhat. Figure 49 shows the relationship that was used in constructing the tables of capacities of stacks, branches, sanitary building drains, and sanitary building sewers (Tables 7.4.11.B to 7.4.11.D.).

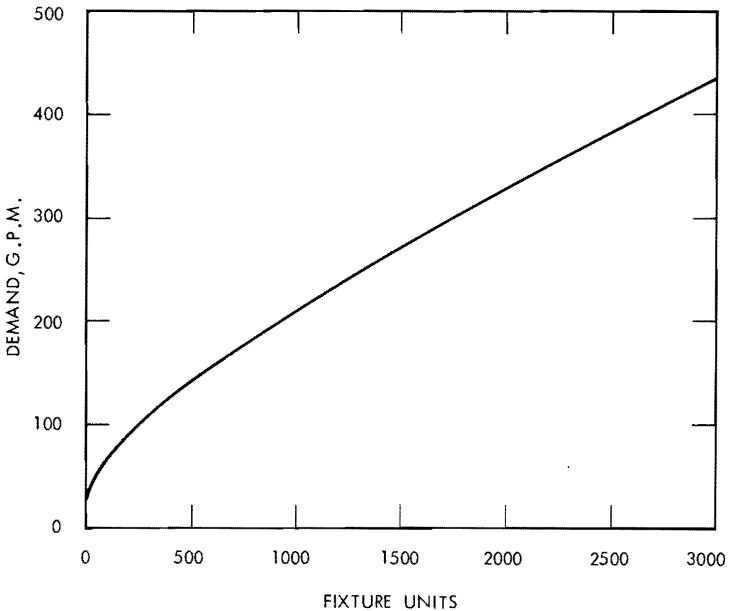

Figure 49 Relationship between fixture units and demand, gpm

Although the curve in Fig. 49 was used to prepare Code tables, it was not included in the National Building Code. Instead, a single approximate conversion factor is given in the Code so that a continuous flow from a fixture may be converted from gallons per minute to fixture units in order to determine the total hydraulic load on the sanitary drainage system. The conversion factor which is given in Sentence 7.4.11.4.(1), is 2 fixture units per gallon per minute. The discharge from a continuous flow fixture in gallons per minute when multiplied by 2 gives the hydraulic load in fixture units, and that load is added to the fixture unit load from other fixtures to give the total load that the sanitary drainage pipe must carry.

The hydraulic load that is produced by storm water runoff depends both on the size of the area that is drained and local rainfall intensity. The capacities of storm drainage pipes and combined sewers in Tables 7.4.11.E. to 7.4.11.G. have been expressed in terms of the number of square feet of drainage area that they can serve when the local rainfall intensity is 1 inch in 15 minutes. The necessary correction factor for areas where the rainfall intensity is higher or lower than 1 inch in 15 minutes is provided by Sentence 7.4.11.5.(1) which requires that the actual area drained be multiplied by the rainfall intensity figure from Appendix E.

When plumbing fixtures are connected to a combined sewer, the hydraulic load from the fixtures must be converted from fixture units to square feet or, in the case of continuous flow, from gallons per minute to square feet so that these loads can be added to the hydraulic loads from roofs and paved surfaces. As already pointed out, the relationship between fixture units and gallons per minute and, consequently, the relationship between fixture units and square

feet is not straightforward and an approximate conversion factor has been adopted. The conversion factor which is given in Sentence 7.4.11.6.(1) is 3.9 sq ft per fixture unit, except where the load is less than 256 fixture units a round figure of 1000 sq ft is to be used. In the case of continuous flow fixtures that are connected to combined sewers or storm sewers, the conversion factor given in Sentence 7.4.11.4.(2) is 29 sq ft per gallon per minute. This conversion factor is not an approximation but is calculated exactly.

It should be noted carefully that the conversion factors given in Sentences 7.4.11.4.(1) and 7.4.11.6.(1) are designed to convert in one direction only and must not be used to convert from fixture units to gallons per minute in the one instance nor from square feet to fixture units in the other instance.

In summary it should be noted that

- (a) in sanitary drainage systems all hydraulic loads are converted to fixture units, and
- (b) in storm drainage systems or combined drainage systems all hydraulic loads are converted to square feet.

#### PROCEDURE FOR SELECTING PIPE SIZES

The following is an outline, with examples, of the procedures to be followed in determining the size of each section of drainage piping.

1. Sanitary drainage pipes, e.g., branches, stacks, building drains, building sewers:
  - (a) Determine the load, in fixture units, from all fixtures except continuous flow fixtures;
  - (b) Determine the load in gallons per minute from all continuous flow fixtures and multiply the number of gallons per minute by 2 to obtain the number of fixture units;
  - (c) Add loads (a) and (b) to obtain the total hydraulic load on pipe in fixture units; and
  - (d) Consult appropriate table, Table 7.4.11.B, 7.4.11.C, or 7.4.11.D, and select the pipe size.

Note that no pipe size can be smaller than that permitted in Subsection 7.4.12.

2. Storm drainage pipes, e.g., gutters, leaders, horizontal pipes, building drains, building sewers:
  - (a) Determine the area in square feet of roofs and paved surfaces according to Sentence 7.4.11.5.(1);
  - (b) Determine the local rainfall intensity (15-minute rainfall) from Appendix E;
  - (c) Multiply (a) by (b) to obtain the hydraulic load in square feet;
  - (d) If a fixture discharges a continuous flow to the storm system, multiply its load in gallons per minute by 29 to obtain the hydraulic load in square feet;

- (e) Add loads (c) and (d) to obtain the total hydraulic load on the pipe in square feet; and
- (f) Consult the appropriate table, Table 7.4.11.E, 7.4.11.F, or 7.4.11.G. and select pipe or gutter size.

Note that no pipe size can be smaller than that permitted in Subsection 7.4.12.

3. Combined drainage pipes, e.g., building drains, building sewers:

- (a) Determine the total load in fixture units from all fixtures except continuous flow fixtures;
- (b) If the fixture unit load exceeds 256, multiply it by 3.9 to determine the equivalent hydraulic load in square feet. If the fixture unit load is 256 or fewer fixture units, the hydraulic load is 1000 sq ft;
- (c) Obtain the hydraulic load from roofs and paved surfaces in the same manner as for storm drains (see 2 (a), (b) and (c));
- (d) Obtain the hydraulic load, in square feet, from any continuous flow source that is connected to the sanitary or storm drainage system in the same manner as for storm drainage pipes (see 2 (d));
- (e) Add hydraulic loads (b), (c) and (d) to obtain the total hydraulic load on pipe in square feet, and
- (f) Consult Table 7.4.11.E and select the pipe size.

Note that no pipe can be smaller than that permitted in Subsection 7.4.12.

### EXAMPLES

**EXAMPLE I: Determination of the Size of Storm Drainage Components for Building shown in Figs. 50 and 51.**

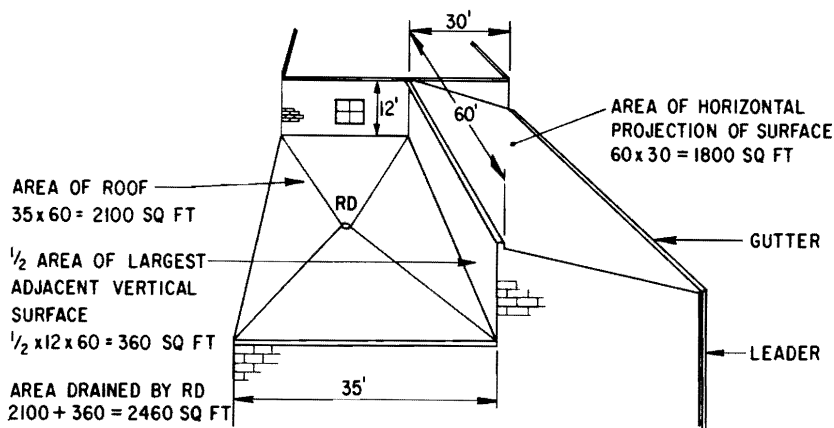

Figure 50 Storm drainage areas (Example I)

Step No. 1. — Determine the hydraulic load from the roofs.

Area drained by gutter	1800 sq ft	
Area drained by roof drain	2460 sq ft	
If the local rainfall intensity is 1.0 inch:		
the load on the gutter (leader No. 2)	is (1 x 1800)	1800 sq ft
the load on the roof drain (leader No. 1)	is (1 x 2460)	2460 sq ft
If the local rainfall intensity is 0.6 inch:		
the load on the gutter (leader No. 2)	is (0.6 x 1800)	1080 sq ft
the load on the roof drain (leader No. 1)	is (0.6 x 2460)	1476 sq ft

Step No. 2 — Determine the size of storm drainage components.

Using the appropriate hydraulic loads, the size of storm drainage components can be determined from Tables 7.4.11.E, 7.4.11.F and 7.4.11.G. These values are tabulated in Fig. 52 for rainfall intensities of 1 in. and 0.6 in. in 15 minutes.

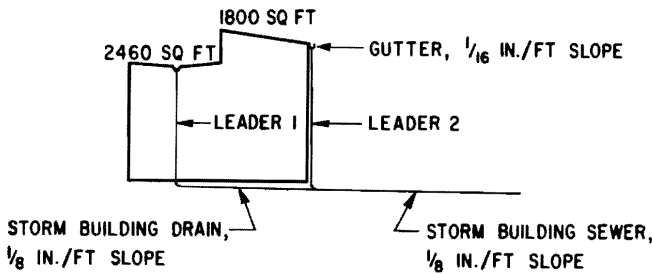

Figure 51 Storm drainage components (Example I) (elevation view)

	Area Drained, sq ft	15-min. Rainfall Intensity, in.				Reference Table No.
		1.0		0.6		
		Hydraulic Load, sq ft	Size, in.	Hydraulic Load, sq ft	Size, in.	
Roof drain leader	2460	2460	4	1476	3	7.4.11.G.
Gutter	1800	1800	8	1080	7	7.4.11.F.
Gutter leader	1800	1800	3	1080	2½	7.4.11.G.
Storm building drain	2460	2460	5	1476	4	7.4.11.E.
Storm building sewer	4260	4260	6	2556	5	7.4.11.E.

Figure 52 Storm drainage pipe sizes (Example I)



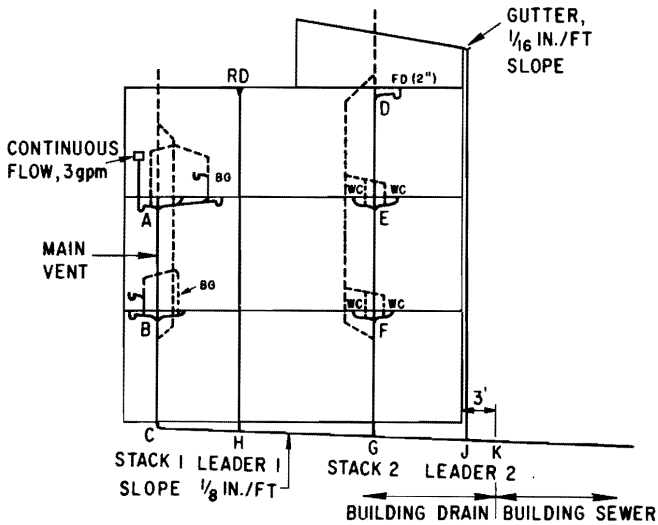

Figure 53 Building drainage system (Example II)

**EXAMPLE II:** Determination of the Size of Drainage Pipes for Building shown in Fig. 53.

Figure 53 represents the same building as in Example I (Figs. 50 and 51) except that two soil-or-waste stacks have been added and the 15-minute rainfall intensity is assumed to be 0.6 in. To determine the size of soil-or-waste stacks, the hydraulic load must be calculated in terms of fixture units.

Step No. 1. — Determine the Size of Stack No. 1 in Fig. 53.

#### Pipe Section AB

Hydraulic load:

$$\begin{aligned}
 1 \text{ bathroom group} &= 8 \text{ fixture units (Table 7.4.8.A.)} \\
 3 \text{ gpm} \times 2 &= 6 \text{ fixture units (Sentence 7.4.11.4.(1))} \\
 \text{Total} &= 14 \text{ fixture units}
 \end{aligned}$$

Table 7.4.11.B. Column, 2, permits a 2½-in. pipe but Subsection 7.4.12. requires a 3-in. pipe. (The soil-or-waste stack is part of a main vent (Article 7.4.12.8.) and the pipe serves a water closet (Article 7.4.12.2). USE 3-in. PIPE.

#### Pipe Section BC

Hydraulic load:

$$\begin{aligned}
 2 \text{ bathroom groups} &= 16 \text{ fixture units (Table 7.4.8.A.)} \\
 3 \text{ gpm} \times 2 &= 6 \text{ fixture units} \\
 \text{Total} &= 22 \text{ fixture units}
 \end{aligned}$$

Table 7.4.11.B., Column 2, permits a 3-in. pipe. This conforms to Subsection 7.4.12. USE 3-in. PIPE

Step No. 2. — Determine the Size of Stack No. 2 in Fig. 53.

Pipe Section DE

Hydraulic load:

1 floor drain = 3 fixture units (Table 7.4.8.A.)

Table 7.4.11.B., Column 2, permits a 2-in. pipe. USE 2-in. PIPE.

Pipe Section EF

Hydraulic load:

2 water closets + 1 floor drain = 15 fixture units (Table 7.4.8.A.)

Table 7.4.11.B., Column 2, permits a 2½-in. pipe, but Article 7.4.12.2. requires a 3-in. pipe. USE 3-in. PIPE.

Pipe Section FG

Hydraulic load:

4 water closets + 1 floor drain = 27 fixture units (Table 7.4.8.A.)

Table 7.4.11.B., Column 2, permits a 3-in. pipe. This conforms to Sub-section 7.4.12. USE 3-in. PIPE

Step No. 3. — Determine the Size of Building Drain in Fig. 53.

Pipe section HGJK (Fig. 53) of the building drain is, by definition, a combined building drain. Section CH does not conduct storm water and is, by definition, a sanitary building drain.

Pipe Section CH

Hydraulic load: the hydraulic load on this section is equal to the hydraulic load from Stack No. 1 which is 22 fixture units.

Table 7.4.11.D., Column 3, permits a 4-in. pipe. This conforms to Sub-section 7.4.12. USE 4-in. PIPE

Pipe Section HG

Hydraulic load: the hydraulic load on this section is the sum of:

the sanitary load on stack No. 1 (see step No. 1) = 16 fixture units. As this sanitary load is less than 256 fixture units, according to Sentence 7.4.11.6.(1) the equivalent storm load is .....	1000 sq ft
the storm load on leader No. 1 (see step No. 1 in Example I)	1476 sq ft
the load from continuous flow fixtures (see step No. 1) = 3 gpm. Therefore the equivalent storm load is 3 gpm × 29	87 sq ft
Total Hydraulic Load	2563 sq ft

Table 7.4.11.E., Column 2, requires a 5-in. pipe. USE 5-in. PIPE.

Pipe Section GJ

Hydraulic load: the hydraulic load on this section is the sum of:

the sanitary load on stacks Nos. 1 and 2 (see steps Nos. 1 and 2

respectively) = 16 fixture units + 27 fixture units = 43 fixture units. Therefore the equivalent storm load is . . . . .	1000 sq ft
the storm load on leader No. 1 (see step No. 1, Example I)	1476 sq ft
the load from continuous flow fixtures (step No. 1) = 3 gpm. Therefore the equivalent storm load is 3 gpm × 29	87 sq ft
Total Hydraulic Load	2563 sq ft

Table 7.4.11.E., Column 2, requires a 5-in. pipe. USE 5-in. PIPE.

#### Pipe Section JK

Hydraulic load: the hydraulic load on this section is the sum of the hydraulic loads from:

stacks Nos. 1 and 2 . . . . .	1000 sq ft
the continuous flow fixture . . . . .	87 sq ft
leaders Nos. 1 and 2 (1476 + 1080) . . . . .	2556 sq ft
Total Hydraulic Load	3643 sq ft

Table 7.4.11.E., Column 2, requires a 6-in. pipe. USE 6-in. PIPE.

## SECTION 7.5 VENTING SYSTEM

### SUBSECTION 7.5.1 VENT PIPES FOR TRAPS

Venting for traps

7.5.1.1.(1) Except as provided in Sentences (3) and (4), a trap shall be protected by

(a) a vent pipe, or

(b) a wet vent installed according to Articles 7.5.1.6., 7.5.1.7. or 7.5.1.8.

Vents for future fixtures

(2) Where a fixture drain is installed to provide for a fixture that may be installed at a future time, a vent pipe or a wet vent installed according to Articles 7.5.1.6., 7.5.1.7., or 7.5.1.8., shall be connected to the fixture drain.

Exceptions

(3) A trap need not be protected where

(a) it serves an indirectly connected fixture, a subsoil drainage pipe, or a storm drainage system, or

(b) it is connected to a storm drainage system.

See Fig. 54.

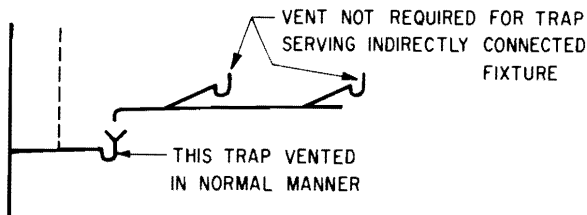

Figure 54 Trapping indirectly connected fixtures

- (4) A trap that serves a basement floor drain need not be protected where
- the diameter of the trap is 3 in. (76 mm) or more,
  - the length of the fixture drain is not greater than 5 ft. (1.5 m) and is not less than 18 in. (457 mm), and
  - the fixture drain is connected above the horizontal centreline of the building drain when the connection is within 5 ft (1.5 m) of a soil-or-waste stack.

Exception  
for basement  
floor drain

See Fig. 55.

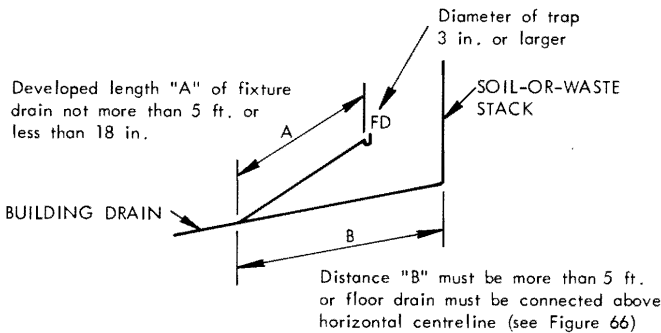

Figure 55 Basement floor drains

7.5.1.2.(1) Where a nominally horizontal branch serves, according to Acticles 7.5.1.6., 7.5.1.7. or 7.5.1.8, as the vent pipe of a fixture other than

- a water closet,
- another fixture that relies on siphonic action for its operation, or
- an S-trap standard

the length of the fixture drain shall be at least 18 in. (457 mm).

7.5.1.3.(1) Except for water closets, S-trap standards or fixtures that depend on siphonic action for the proper functioning of the fixture, every fixture trap shall have a protecting vent so located that

Fall on  
fixture drain

- the total fall in the fixture soil-or-waste pipe from the trap weir to the vent pipe is not greater than the diameter of the waste pipe, and
- the developed length of the waste pipe from the trap weir to the vent pipe is not less than twice the diameter of the soil-or-waste pipe nor more than 5 ft (1.5 m).

(2) Where a water closet or another fixture that relies on siphonic action for its operation is loop vented, circuit vented or wet vented, the vertical distance from the outlet of the fixture to the invert of the branch to which the fixture drain is connected shall not exceed 30 in. (762 mm).

**Connection of drain to vent pipe**

**7.5.1.4.(1) Where a fixture drain is connected to a continuous waste and vent pipe the connection shall be made with a sanitary T-Y.**

**(2) Not more than one 90-deg. or two 45-deg. bends shall be installed in a fixture drain between the trap weir and the vent pipe or soil-or-waste pipe that also serves as a vent pipe.**

See Fig. 56.

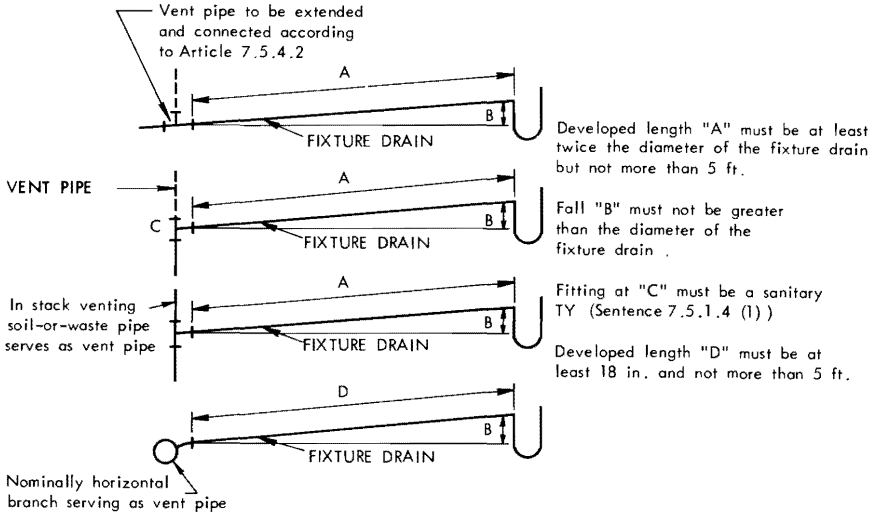

(a) Fixtures other than water closets and similar fixtures

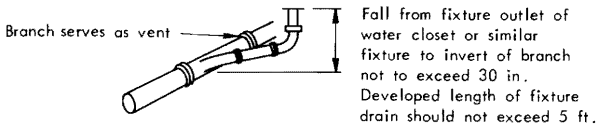

(b) Water closets and similar fixtures

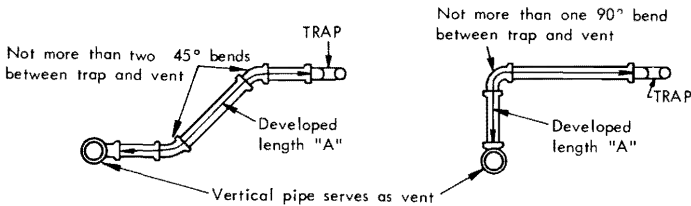

(c) Plan view of fixture drains

**Figure 56 Vent connections**

**7.5.1.5.** *Continuous vents or stack vents may serve as dual vents for not more than two fixtures that are connected at the same level to the top of the branch or soil-or-waste stack of which the vent pipe is an extension.*

Dual venting

See Fig. 57.

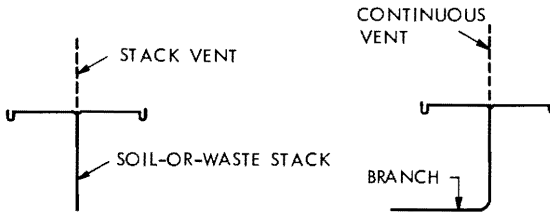

Figure 57 Dual venting

**7.5.1.6.(1)** Subject to Articles 7.5.1.2. to 7.5.1.4., a branch that is extended as a dual vent or a section of a fixture drain that is extended as a continuous vent may serve as a wet vent for one or two fixtures provided

Wet venting

- (a) the wet vented fixture or fixtures are connected to a nominally horizontal part of the fixture drain,
- (b) not more than three fixture units including not more than two fixtures are drained to the branch or fixture drain upstream of the wet vented fixture or fixtures,
- (c) where two water closets are wet vented they are connected by a double Y fitting,
- (d) where a water closet and another fixture are wet vented, the water closet is connected downstream of the other fixture, and
- (e) the size of the wet vent is
  - (i) at least 1¼ in. (32 mm) where the size of the largest fixture drain of a wet vented fixture is not more than 1½ in. (38 mm),
  - (ii) at least 1½ in. (38 mm) where the size of the largest fixture drain of a wet vented fixture is 2 in. (51 mm), or
  - (iii) at least 2 in. (51 mm) where the size of the largest fixture drain of a wet vented fixture is more than 2 in. (51 mm).

See Fig. 58, p. 78.

(2) Except where a wet vented fixture is a water closet or other fixture that relies on siphonic action for its operation, or an S-trap standard, the length of the fixture drain of a wet vented fixture shall be at least 18 in. (457 mm).

This Sentence duplicates the requirements of Article 7.5.1.2.

See Fig. 56(a), p. 76.

**7.5.1.7.(1)** Subject to Articles 7.5.1.2. to 7.5.1.4., a section of soil-or-waste stack or of a branch that is extended as a continuous vent may serve as a vent pipe for

Stack venting

- (a) two fixtures connected separately and directly into the stack through

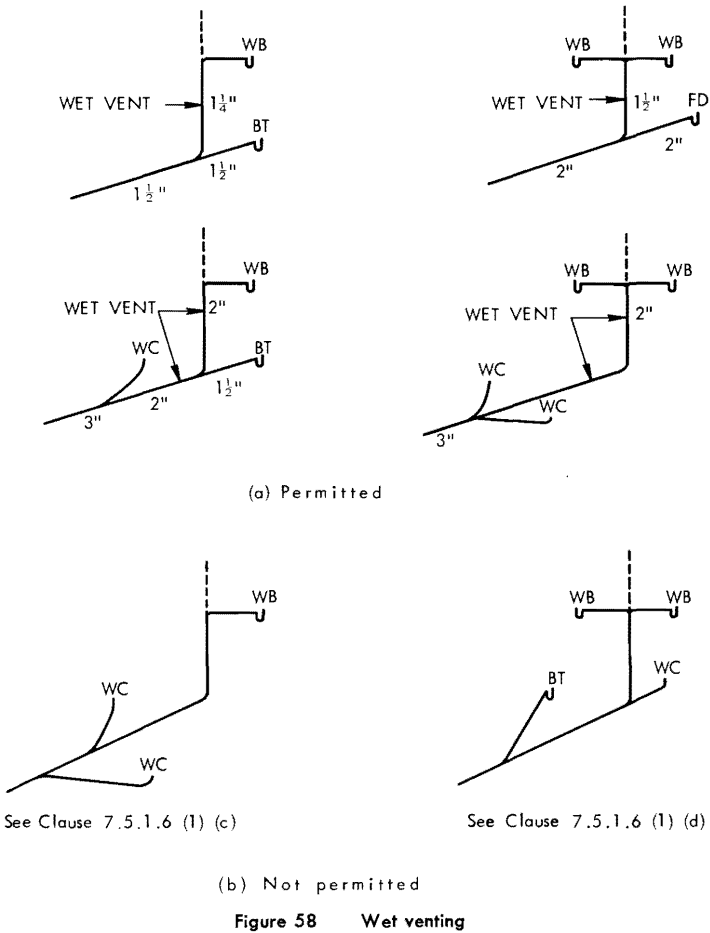

**an approved double fitting, providing each fixture drain does not exceed 5 ft (1.5 m) in developed length and no other fixtures discharge into the stack above such connection,**

- (b) **one water closet and three other fixtures installed on the same floor, provided**
- (i) **the developed length of each fixture drain does not exceed 5 ft (1.5 m),**
  - (ii) **all fixtures connect separately and directly into the stack,**
  - (iii) **the waste pipes for the three other fixtures do not exceed 1½ in. (38 mm) in diameter and connect to the stack above the water closet connection, and**
  - (iv) **the stack continues full size to the topmost fixture connection, or**
- (c) **two water closets and three other fixtures installed on the same floor,**

provided the installation conforms to the requirements of clause (b) and the water closets are connected separately and directly into the stack through an approved double fitting.

Clause (a) duplicates the requirements of Article 7.5.1.5, which deals with dual venting. See Fig. 57, p. 77. Note that fewer than 4 other fixtures may be stack vented in conjunction with the one or two water closets, provided other requirements are met. See Fig. 59.

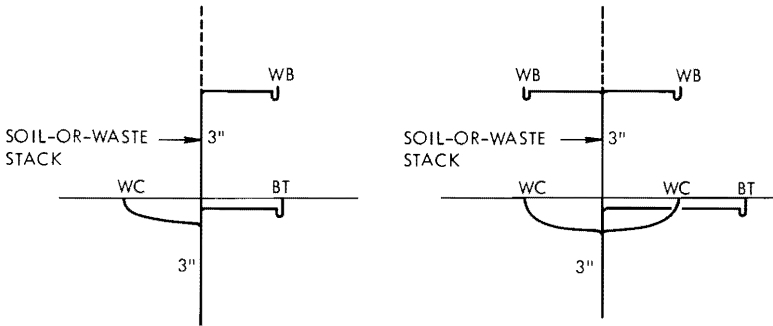

(a) Fixtures connected to a soil-or-waste stack

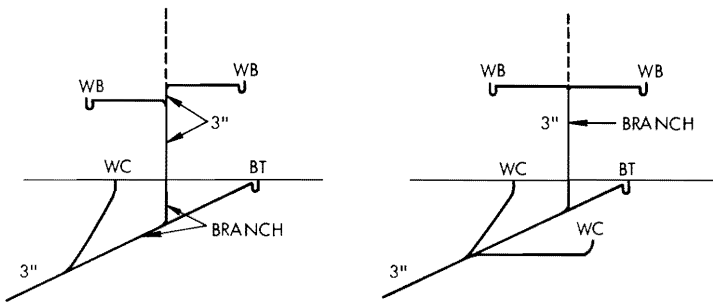

(b) Fixtures connected to a branch

Figure 59 Stack venting

7.5.1.8.(1) Subject to Articles 7.5.1.2. to 7.5.1.4., a *nominally horizontal branch* may serve as the *vent pipe* for not more than 8 traps other than traps that serve wash basins or sinks or other wall outlet fixtures that are connected to it provided

Circuit or loop venting

- (a) every fixture that is connected to the branch is in the same storey, and
- (b) a circuit vent or a loop vent is connected to the branch between the two most upstream fixtures that are vented by the branch.



(2) A relief vent shall be connected to the branch when the downstream end of the branch is connected to

- (a) a soil-or-waste stack, building drain or branch that serves a fixture on a higher storey,
- (b) a building drain or branch downstream of a fixture or fixtures that have a hydraulic load of more than six fixture units, or
- (c) a soil-or-waste stack below a water closet.

(3) Where a relief vent is required it shall be connected to the branch downstream of the connection from the most downstream fixture that is vented by the branch.

(4) A change in direction of more than 45 deg. shall not be made in the branch downstream of the most upstream fixture that is vented by the branch.

(5) A branch may serve as a vent pipe for more than 8 fixtures if an additional relief vent is connected to the branch for every 8 additional fixtures or fraction thereof.

For the purposes of this Code, a circuit vent can be considered to be the same as a loop vent and the terms can be used interchangeably since the only difference between the two is that a circuit vent connects at its upper end to a vent stack and a loop vent connects at its upper end to a stack vent. See Figs. 60 and 61.

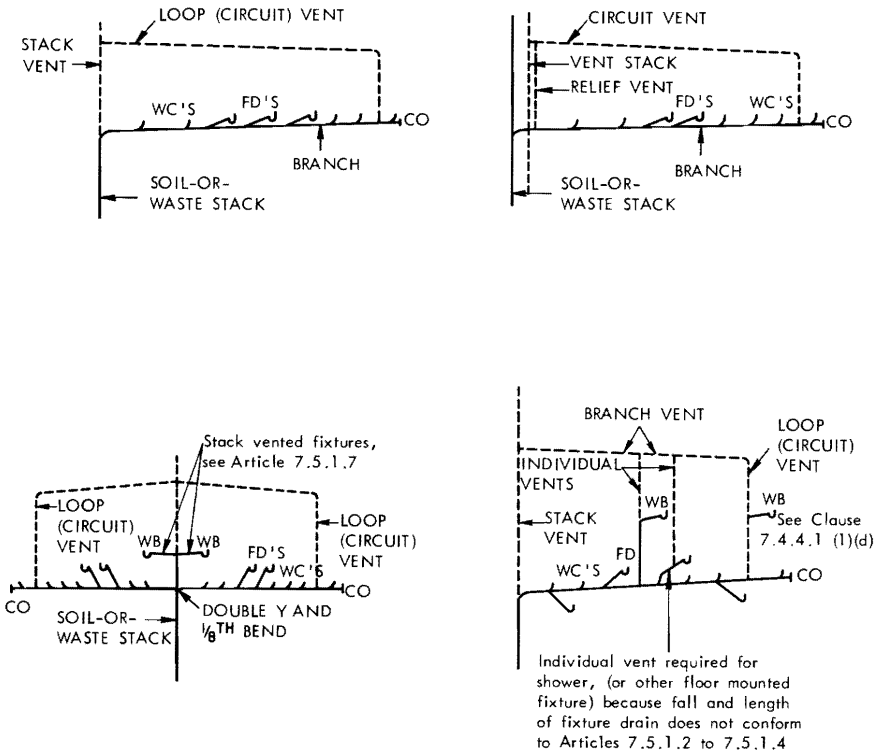

Figure 60 Circuit and loop venting

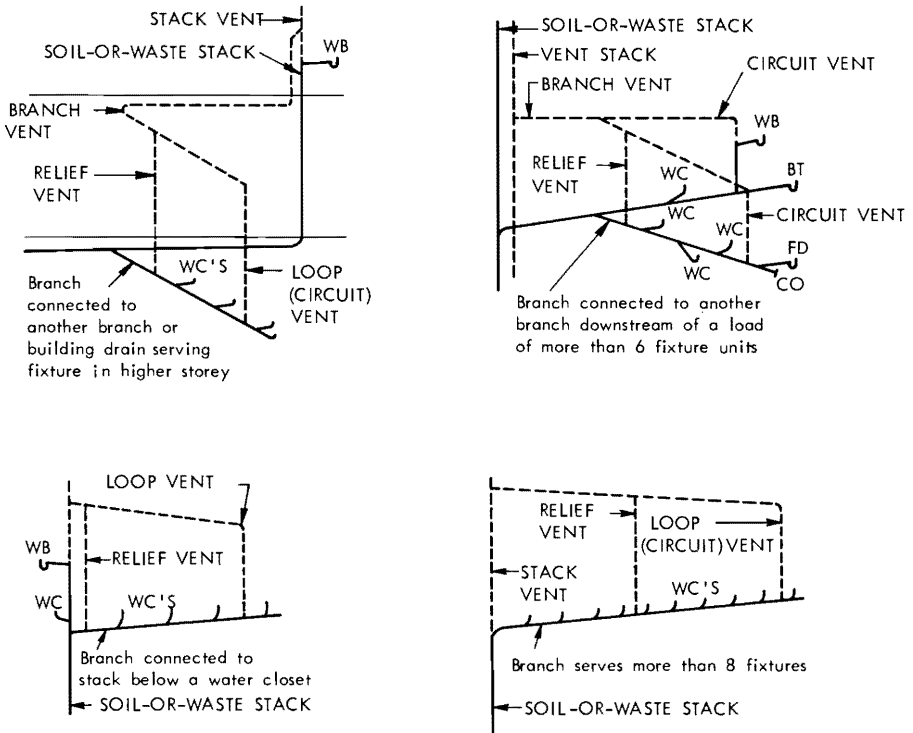

Figure 61 Relief venting

**SUBSECTION 7.5.2. VENT PIPES FOR WASTE STACKS**

**7.5.2.1. Every soil-or-waste stack shall be extended to form a stack vent.**

**Stack vent**

**7.5.2.2.(1) A vent stack shall be installed in conjunction with every soil-or-waste stack when vents are required in two or more storeys.**

**(2) Every vent stack shall connect full size at its base to a soil-or-waste stack at or immediately below the lowest horizontal waste pipe or fixture connection.**

Sentence (1) requires that a vent stack be installed in conjunction with each soil-or-waste stack that serves vented fixtures, other than stack vented fixtures, on more than one floor. Where a vent stack connects to a soil-or-waste stack it must do so through a double fitting or through a single fitting immediately below the lowest drain connection to the stack. The vent stack may also be connected to the building drain at the base of the soil-or-waste stack.

**7.5.2.3.(1) Except as provided in Sentence (3) where a soil-or-waste stack extends through ten or more storeys, a yoke vent shall be connected to the**

**Yoke vent**

stack at every fifth storey, measured from the top storey downward and immediately above each change of direction from vertical to horizontal.

(2) The connection between every yoke vent and soil-or-waste stack shall be

(a) made with a Y, and

(b) located below the lowest soil-or-waste pipe that is connected to the stack from the storey in which the connection is made.

(3) Yoke vents need not be installed provided relief vents full size of the fixture branch are installed on every floor.

Sentence (1) requires that yoke vents be installed at the bottom storey of each section of 5 storeys starting with the top storey served by the soil-or-waste stack. The connection of the yoke vent to the soil-or-waste stack will normally be made in the storey below. See Figs. 62 and 63.

Sizing of yoke vents is given in Article 7.5.5.9.

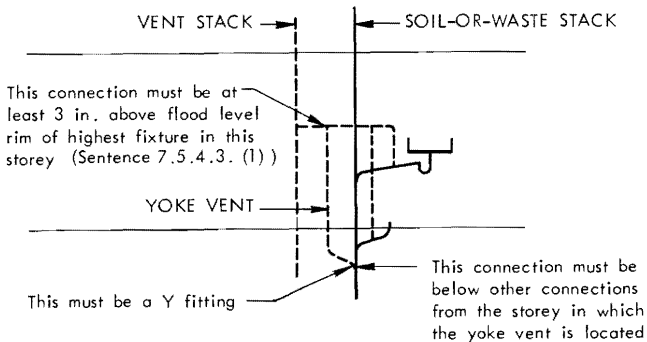

Figure 62 Yoke vent connections

Stack 1 extends through 11 storeys and has no horizontal offsets. Yoke vents are required at the fifth storey and tenth storey from the top storey of the building.

Stack 2 extends through 10 storeys but serves fixtures on the top storey so must have a yoke vent connection to the stack at the fifth and tenth storeys measured downward from the top storey served by the stack. In the tenth storey there is a change of direction in the stack from vertical to horizontal; therefore, a yoke vent is required immediately above this change of direction. Another change of direction occurs in the fourth and fifth

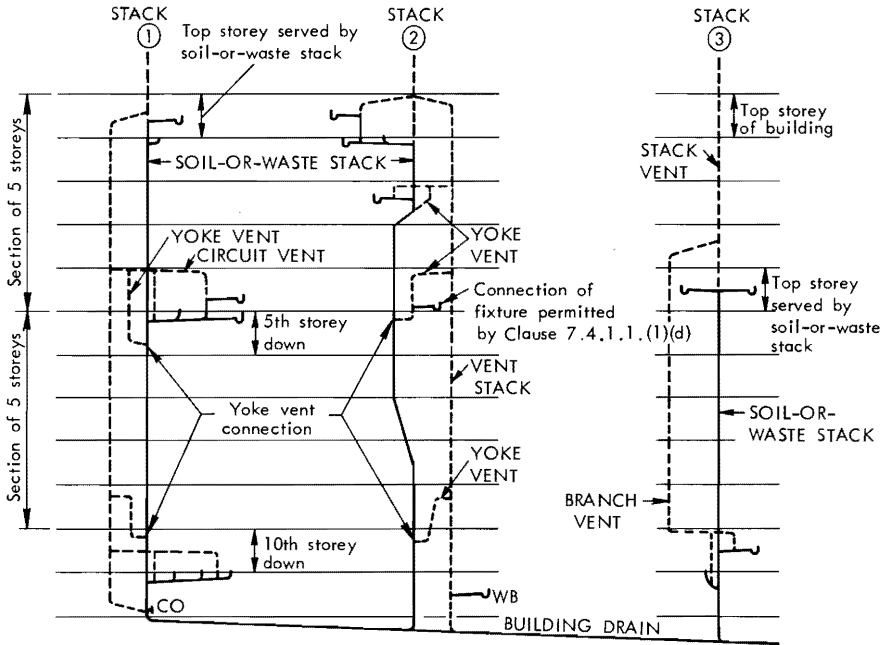

Figure 63 Yoke vents for a 12-storey building

storeys of the building but because this change in direction is less than 45 deg. from the vertical a yoke vent is not required. Stack 3 extends through only 7 storeys so yoke vents are not required. If fixtures requiring vents were installed on another floor then according to Sentence 7.5.2.2.(1), the branch vent would have to be replaced by a vent stack.

**7.5.2.4. The stack vent of a soil-or-waste stack shall not be reduced if the soil-or-waste pipe rises more than 25 ft (7.6 m) measured vertically from its connection with a drain or stack to the highest fixture branch.**

See Fig. 64.

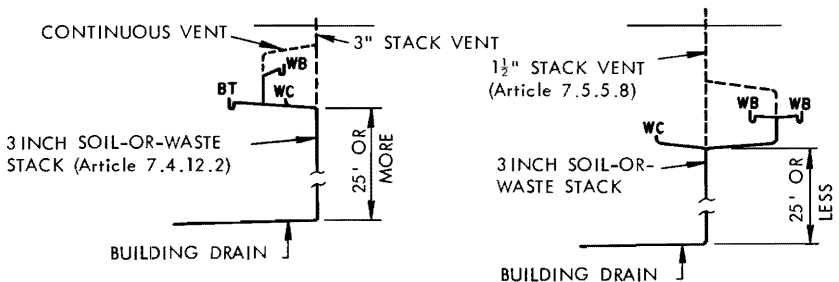

Figure 64 Minimum size of stack vents

### SUBSECTION 7.5.3. MISCELLANEOUS VENT PIPES

Venting of sewage sump

7.5.3.1. Every *sump* that receives *sewage* shall be provided with a *vent pipe* that is connected to the top of the *sump*.

Venting of oil interceptor

7.5.3.2.(1) Every oil *interceptor* shall be provided with two *vent pipes* that are connected to the high points of opposite ends of the *interceptor* and

- (a) the *vent pipes* shall be extended directly to open air,
- (b) one of the *vent pipes* shall be terminated at 12 in. (305 mm) above the other to promote circulation of air through the *interceptor*, and
- (c) adjacent compartments shall be connected to each other by a *vent*.

See Fig. 65.

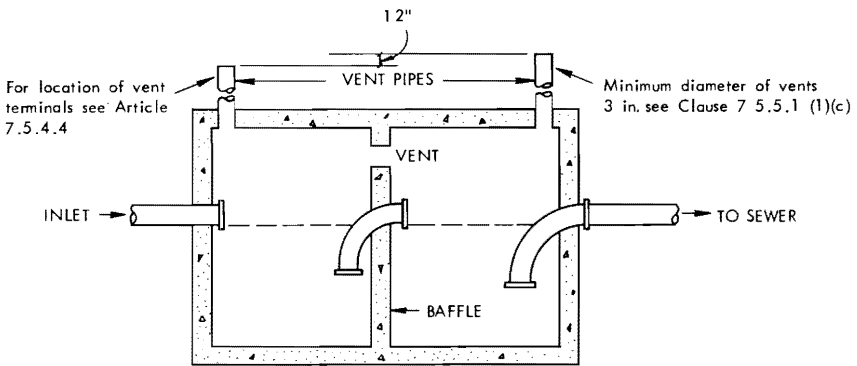

Figure 65 Venting of oil interceptor

Venting of building-trap

7.5.3.3. Where a *building-trap* is installed a *fresh air inlet* shall be connected to the *building drain* upstream of and within 4 ft (1.2 m) of the *building-trap* and downstream of any *fixture connection* or *branch drain*.

See Fig. 40, p. 56, which illustrates cleanouts on building drains.

### SUBSECTION 7.5.4. ARRANGEMENT OF VENT PIPES

Drainage of vent pipes

7.5.4.1. Every *vent pipe* shall be installed without depressions in which moisture can collect, and shall be graded and connected so that moisture can drain back to the *drainage system*.

Vent pipe connections

7.5.4.2.(1) Every *vent pipe* shall be connected as directly as possible from its lower end to outside air, and where it is possible to do so the pipe shall be installed in a *nominally vertical* position.

(2) Where a *vent pipe* is connected to a *nominally horizontal soil-or-waste pipe* the connection shall be above the horizontal centreline of the *soil-or-waste pipe* and the *vent pipe* shall be extended directly to the nearest wall or vertical member.

See Fig. 66.

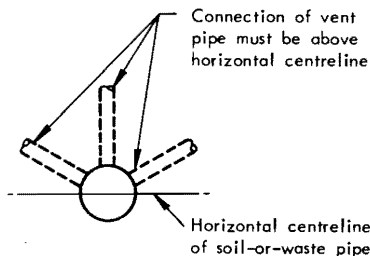

Figure 66 Vent pipe connections

Fittings used to connect vent pipes to nominally horizontal soil-or-waste pipes are specified in Subsection 7.2.4.

**7.5.4.3.(1)** Where a *vent pipe* is connected to another *vent pipe* the connection shall be located at least 3 in. (76 mm) above the *flood level rim* of every *fixture* that is served by either *vent pipe*.

Vents to connect above fixtures they serve

(2) Every connection between a *yoke vent* and *vent stack* or *branch vent* shall be located at least 3 in. (76 mm) above the *flood level rim* of every *fixture* in the *storey* in which the connection is made.

See Fig. 62, p. 82.

**7.5.4.4.(1)** The upper end of every *vent pipe* that is not terminated in open air shall be connected to a *vent pipe* or *venting system* that is terminated in open air.

Terminals

(2) The upper end of every *stack vent* or *vent stack* shall be terminated in open air or be connected within the *building* to another *stack vent* or *vent stack* or to a *header*.

(3) The upper end of every *vent pipe* that is terminated in open air, other than

- (a) a *fresh air inlet*,
- (b) a *vent pipe* that serves an *oil interceptor*, or
- (c) a *vent pipe* that is installed when an existing *drainage system* is extended

shall be extended through a roof.

(4) Where a *vent pipe* is terminated in open air the terminal shall be located

- (a) at least 3 ft (915 mm) above or 12 ft (3.7 m) in any direction from any *air inlet*, *window* or *door*,
- (b) at least 7 ft (2.1 m) above or 12 ft (3.7 m) in any direction from a *roof* that is used for other than *weather protection*, and
- (c) except for a *fresh air inlet*, at least 7 ft (2.1 m) above the *ground*.

(5) Where a *vent pipe* passes through a *roof* it shall be terminated at least

**3 in. (76 mm) above the roof, and in any event sufficiently high to prevent entry of roof drainage.**

See Figs. 67 and 68 which illustrate vent pipe terminals.

For additional requirements for vent pipe terminals see the following: Sentence 7.2.9.3.(1) for flashing; Article 7.3.5.7. for support above roof; Article 7.3.6.4. for insulation; and Sentence 7.5.5.1.(1) for minimum size.

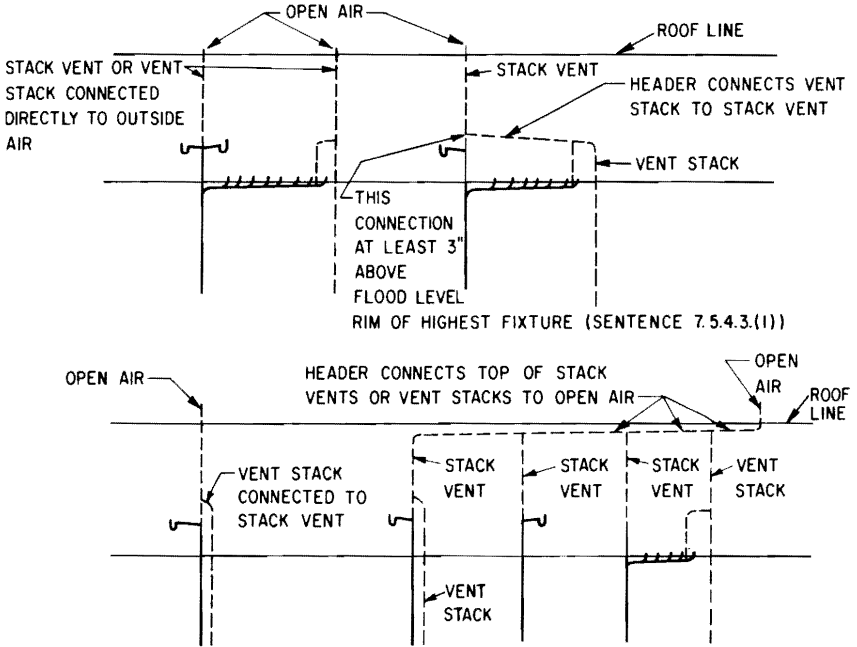

Figure 67 Vent pipe terminals

### SUBSECTION 7.5.5. SIZE OF VENT PIPES

A detailed example of the sizing of vent pipes is given at the end of this Subsection.

#### Minimum diameter

#### 7.5.5.1.(1) The diameter of every vent pipe shall

- (a) be at least 1¼ in. (32 mm) and not less than the diameter set forth in Table 7.5.5.A. according to the largest trap that it serves,
- (b) be at least 3 in. (76 mm) for the part of a vent pipe that is outside the building unless otherwise required by the authority having jurisdiction,
- (c) be at least 3 in. (76 mm) when it serves an oil interceptor, and
- (d) conform to the appropriate requirements of this Subsection for each type of vent.

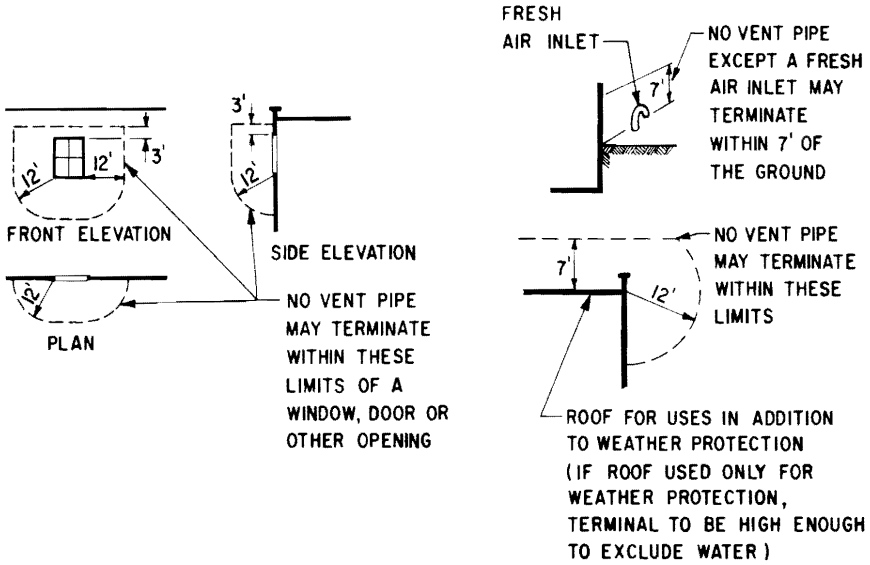

Figure 68 Location of vent pipe terminal

7.5.5.2. Where provision is made in the installation of soil-or-waste pipes for a fixture to be installed at a future time, the venting system shall be adequate to serve the additional fixture.

Size of vents for future fixtures

7.5.5.3. The diameter of every individual vent shall not be less than the diameter set forth in Table 7.5.5.A.

Minimum diameter of individual vent

Table 7.5.5.A.  
Forming Part of Articles 7.5.5.1 and 7.5.5.3.

Size of Trap, in.	Minimum Diameter of Individual Vent, in.
1¼	1¼
1½	1¼
2	1½
2½	1½
3	1½
4	1½
5	2
6	2
Column 1	Column 2

7.5.5.4.(1) The diameter of every continuous vent other than an individual vent shall not be less than the diameter set forth in Table 7.5.5.B. according to the length of the continuous vent and the total hydraulic load from the fixtures that it serves.

Continuous vent

(2) The length of a continuous vent is its developed length from the branch



to which it is connected to a *stack vent, vent stack or header*, and where the *continuous vent* is connected to a *branch vent* the length includes the length of the *branch vent* from its connection with the *continuous vent* to its upper end.

See Fig. 69.

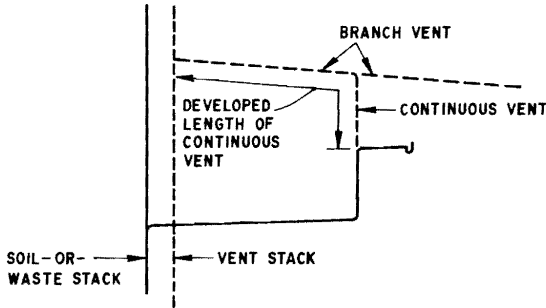

Figure 69 Developed length of continuous vent

**Branch vent or header**

**7.5.5.5.(1)** No section of a *branch vent or header* shall have a *diameter less than the diameter* that is set forth in Table 7.5.5.B. according to

- (a) the total hydraulic load from the *fixtures* that are served by the section, and
- (b) the length of the *branch vent or header* of which it is a part.

**(2)** The length of a *branch vent* is its *developed length* from its upper end to the most distant *soil-or-waste pipe* that it serves, and includes the length of any *vent pipe* that connects it to the *soil-or-waste pipe*.

See Fig. 70.

Note that the diameter of the branch vent should not be less than that of the relief vent or circuit vent, regardless of the size determined by Table 7.5.5.B

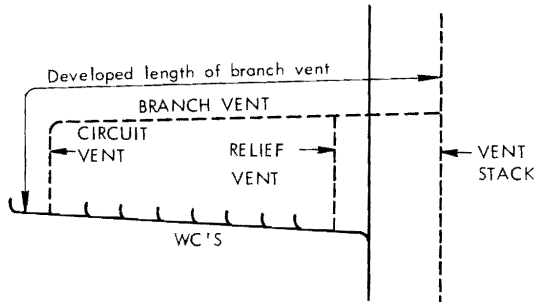

Figure 70 Developed length of branch vent

**(3)** The length of a *header* is its *developed length* from open air to the most distant *soil-or-waste pipe* that it serves, and includes

- (a) the length of any *stack vent or vent stack* that connects it with open air, and
- (b) the length of any *vent pipe* that connects it to the *soil-or-waste pipe*.

See Fig. 71.

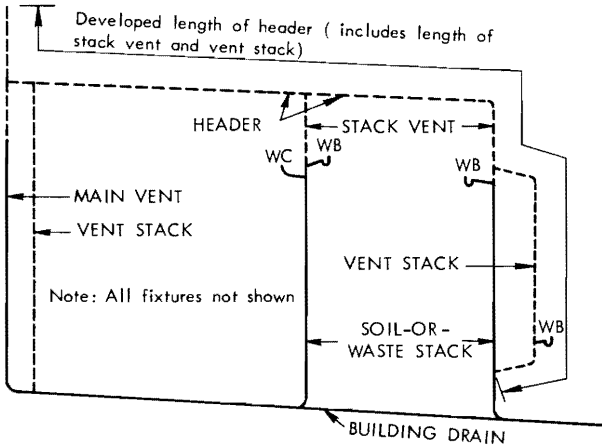

Figure 71 Developed length of header

Table 7.5.5.B.

Forming Part of Articles 7.5.5.4., 7.5.5.5., and Sentence 7.5.5.8.(3)

Total Hydraulic Load, fixture units	Minimum Diameter of Continuous Vent, Branch Vent or Header, in.								
	1¼	1½	2	2½	3	4	5	6	8
	Maximum Length of Vent Pipe, ft								
0-2	30								
3-8	30	100							
9-20	25	50	150						
21-40	15	30	100	300					
41-60	N O T P E R M I T T E D	15	50	80	400				
61-500			30	70	180	700			
501-1100				20	50	200	700		
1101-1900					20	70	200	700	
1901-3600						25	60	250	800
3601-5600						25	60	250	
Column 1	2	3	4	5	6	7	8	9	10

**Sump vent** 7.5.5.6.(1) Except as provided in Sentence (2), the diameter of every vent pipe for a sewage sump shall be not less than one size smaller than the largest inlet pipe to the sump.

(2) The diameter of every vent pipe for a sewage sump shall be not less than 2 in. (51 mm) and need not be larger than 4 in. (102 mm).

For other requirements for sumps, see Articles 7.4.9.4. and 7.5.3.1.

**Circuit vent, loop vent or relief vent** 7.5.5.7. The diameter of every circuit vent, loop vent or relief vent shall not be less than 2 in. (51 mm).

For other requirements for circuit vents, loop vents and relief vents, see Article 7.5.1.8. and Clause 7.4.4.1.(1)(d).

**Stack vent or vent stack** 7.5.5.8.(1) Except as provided for a main vent in Article 7.4.12.8. and as provided in Sentence (3), the diameter of every stack vent or vent stack shall not be less than the diameter set forth in Table 7.5.5.C. according to

- (a) the length of the stack vent or vent stack,
- (b) the diameter of the lowest section of soil-or-waste stack to which it is connected, and
- (c) the hydraulic load that is drained to the lowest section of the stack.

(2) The length of a stack vent or vent stack is its developed length from its lower end to open air, and where the stack vent or vent stack is connected to a header, includes any part of the header that is between the top of the stack vent or vent stack and open air.

In Fig. 71, p. 89, the developed length of the vent stack is the same as that shown as the developed length of the header.

(3) Where a section of a stack vent or vent stack connects the top of one or more headers or other stack vents or vent stacks to open air, the diameter of the section shall be at least equal to the value set forth in Table 7.5.5.B. according to the hydraulic load from the fixtures that are served by the section and the length of the longest stack vent, vent stack or header that is connected to it.

See Fig. 72.

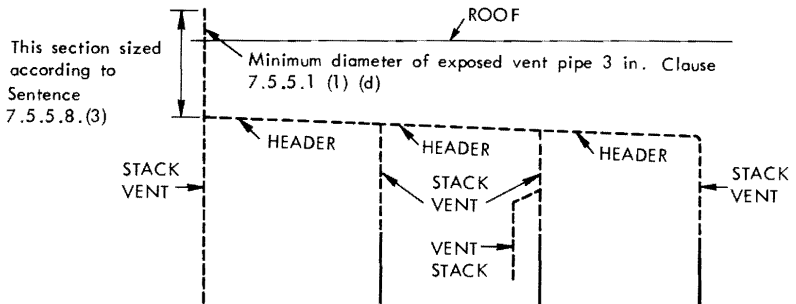

Figure 72 Sizing stack vent and vent stack terminal section

**Table 7.5.5.C.**  
**Forming Part of Sentence 7.5.5.8.(1)**

Diameter of Soil-or-waste Stack, in.	Total Hydraulic Load on Stack fixture units	Minimum Diameter of Stack Vent or Vent Stack, in.									
		1¼	1½	2	2½	3	4	5	6	8	
		Maximum Length of Vent Pipe, ft									
1¼	0-2	30									
1½	0-8	50	150								
2	0-8	30	75	200							
2	9-20	26	50	150							
2½	0-20		45	150	400						
2½	21-42		30	100	300						
3	0-10		30	100	200	600					
3	11-30		15	60	200	500					
3	31-60		15	50	80	400					
4	0-100			35	100	260	1000				
4	101-200			30	90	250	900				
4	201-500			20	70	180	700				
5	0-200	N			35	80	350	1000			
5	201-500	O			30	70	300	900			
5	501-1100	T			20	50	200	700			
6	0-350				25	50	200	400	1300		
6	351-620	P			15	30	125	300	1100		
6	621-960	E				24	100	250	1000		
6	961-1900	R				20	70	200	700		
8	0-600	M					50	150	500	1300	
8	601-1400	I					40	100	400	1200	
8	1401-2200	T					30	90	350	1100	
8	2201-3600	T					25	60	250	800	
10	0-1000							75	125	1000	
10	1001-2500							50	100	500	
10	2501-3300							30	80	350	
10	3301-5600							25	60	250	
Column 1	2	3	4	5	6	7	8	9	10	11	

**7.5.5.9. The diameter of every yoke vent shall be not less than the diameter of the smaller stack to which it is connected.** **Yoke vent**

For other requirements for yoke vents, see Article 7.5.2.3. and Clause 7.4.4.1.(1)(d).

**7.5.5.10. The diameter of every fresh air inlet shall be not less than 4 in. (102 mm).** **Fresh air inlet**

**SIZING OF VENT PIPES**

In the example shown in Fig. 73 the vent pipes have been sized in sequence starting with the simplest subsystem and working toward the outside air terminal at "P." The results have been tabulated in Fig. 74, p. 93.

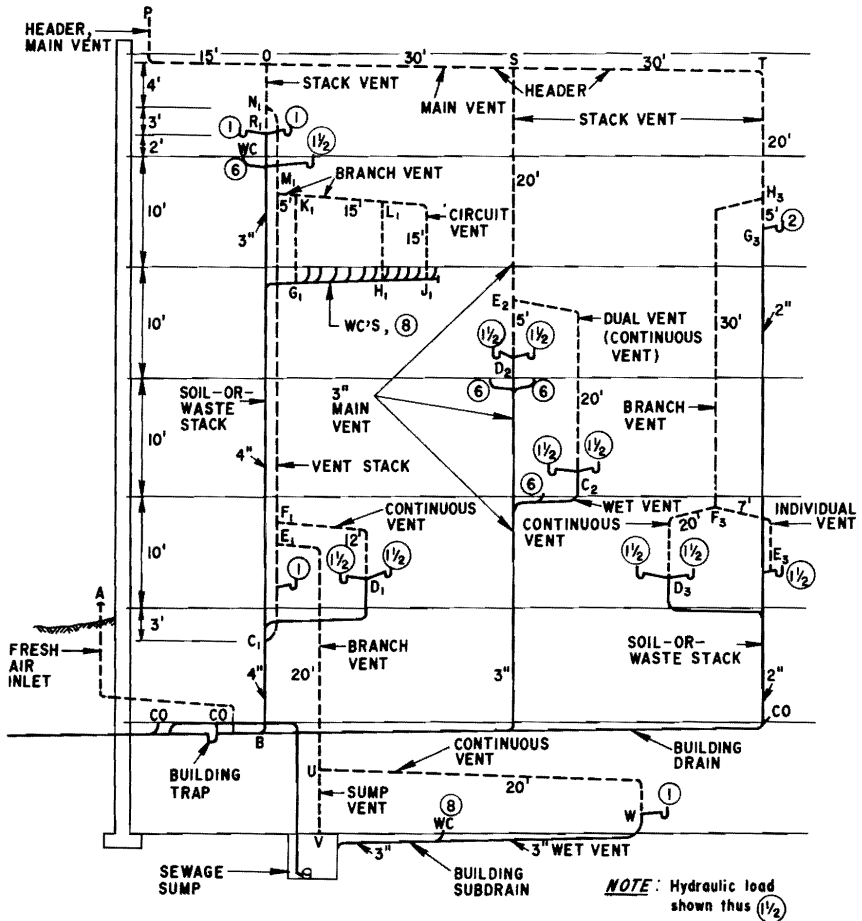

Figure 73 Sizing of building venting system

In Column 1 (Fig. 74) the name of the vent is given and the particular section of the vent pipe is identified, e.g. stack vent is H<sub>3</sub>G<sub>3</sub>. The developed length that must be considered in sizing the particular section of the vent pipe is identified in Column 2, e.g. POSTH<sub>3</sub>G<sub>3</sub>, along with its developed length in feet.

The total hydraulic load of the fixtures served by the vent pipe is given in fixture units in Column 3. In the case of a stack vent or vent stack, Clause 7.5.5.8.(1)(c) states that the hydraulic load to be considered is that drained to the lowest section of the stack. In the example shown, the building subdrainage is vented through vent stack N<sub>1</sub>C<sub>1</sub>, stack vent ON<sub>1</sub>, and header PO. For this reason the hydraulic load of the building subdrainage system has been added to the hydraulic load drained to the 4-in. stack in order to determine the total load served by the vent pipes.

Vent Pipe	Developed Length Used to Determine Size, ft.		Hydraulic load used to determine size, fixture units	Size of Vent Pipe based on length and hydraulic load		Minimum Size of Vent Pipe based on other requirements as noted		Req'd size of Vent Pipe in.
				Table reference	Size, in.	Article reference	Size, in.	
Fresh Air Inlet AB	—	—	—	—	—	7.5.5.10	4	4
Continuous Vent UW	40	(E <sub>1</sub> UW)	9	7.5.5.B	1½	7.5.5.1	1½	1½
Sump Vent UV	—	—	—	—	—	7.5.5.6	2½	2½
Branch Vent E <sub>1</sub> U	40	(E <sub>1</sub> UW)	9	7.5.5.B	1½	7.5.5.6	2½	2½
Individual Vent F <sub>2</sub> E <sub>2</sub>	—	—	1½	—	—	7.5.5.3	1¼	1¼
Continuous Vent F <sub>2</sub> D <sub>2</sub>	50	(H <sub>2</sub> F <sub>2</sub> D <sub>2</sub> )	3	7.5.5.B	1½	7.5.5.1	1¼	1½
Branch Vent H <sub>2</sub> F <sub>2</sub>	50	(H <sub>2</sub> F <sub>2</sub> D <sub>2</sub> )	4½	7.5.5.B	1½	7.5.5.1	1¼	1½
Stack Vent H <sub>2</sub> G <sub>2</sub>	100	(POSTH <sub>2</sub> G <sub>2</sub> )	6½	7.5.5.C	2	7.5.2.4	2	2
Stack Vent TH <sub>2</sub>	100	(POSTH <sub>2</sub> G <sub>2</sub> )	6½	7.5.5.C	2	7.5.2.4	2	2
Header ST	145	(POSTH <sub>2</sub> F <sub>2</sub> D <sub>2</sub> )	6½	7.5.5.B	2	7.5.2.4	2	2
Continuous Vent E <sub>2</sub> C <sub>2</sub>	20	(E <sub>2</sub> C <sub>2</sub> )	9	7.5.5.B	1¼	7.5.5.1	1½	1½
Stack (Main) Vent E <sub>2</sub> D <sub>2</sub>	70	(POSE <sub>2</sub> D <sub>2</sub> )	24	7.5.5.C	2½	7.5.2.4	3	3
Stack (Main) Vent SE <sub>2</sub>	70	(POSE <sub>2</sub> D <sub>2</sub> )	24	7.5.5.C	2½	7.5.2.4	3	3
Header OS	145	(POSTH <sub>2</sub> F <sub>2</sub> D <sub>2</sub> )	30½	7.5.5.B	2½	7.5.2.4	3	3
Continuous Vent F <sub>1</sub> D <sub>1</sub>	12	(F <sub>1</sub> D <sub>1</sub> )	3	7.5.5.B	1¼	7.5.5.1	1¼	1¼
Circuit Vent L <sub>1</sub> J <sub>1</sub>	—	—	88	—	—	7.5.5.7	2	2
Relief Vent L <sub>1</sub> H <sub>1</sub>	—	—	—	—	—	7.5.5.7	2	2
Relief Vent K <sub>1</sub> G <sub>1</sub>	—	—	—	—	—	7.5.5.7	2	2
Branch Vent K <sub>1</sub> L <sub>1</sub>	35	(M <sub>1</sub> K <sub>1</sub> L <sub>1</sub> J <sub>1</sub> )	88	7.5.5.B	2½	7.5.5.1	1½	2½
Branch Vent M <sub>1</sub> K <sub>1</sub>	35	(M <sub>1</sub> K <sub>1</sub> L <sub>1</sub> J <sub>1</sub> )	88	7.5.5.B	2½	7.5.5.1	1½	2½
Vent Stack N <sub>1</sub> C <sub>1</sub>	67	(PON <sub>1</sub> C <sub>1</sub> )	110½	7.5.5.C	2½	7.5.5.6	2½	2½
Stack Vent N <sub>1</sub> R <sub>1</sub>	22	(PON <sub>1</sub> R <sub>1</sub> )	101½	7.5.5.C	2	7.5.2.4	3	3
Stack Vent ON <sub>1</sub>	67	(PON <sub>1</sub> C <sub>1</sub> )	110½	7.5.5.C	2½	7.5.2.4	3	3
Header PO	145	(POSTH <sub>2</sub> F <sub>2</sub> D <sub>2</sub> )	141	7.5.5.B	3	7.5.2.4	3	3
Column 1	Column 2		Col. 3	Col. 4	Col. 5	Col. 6	Col. 7	Col. 8

Figure 74 Table of vent pipe sizes

Column 4 gives the reference table from Part 7, Plumbing Services, of the NBC from which the required size shown in Column 5 has been determined. Where the Code does not specify a method of sizing a vent pipe (i.e. relief vents, fresh air inlets), the spaces in Columns 4 and 5 have been left blank. In many other cases the minimum sizes of vent pipes are set by requirements other than developed length and hydraulic load. The applicable Code reference is given in Column 6 with the corresponding minimum size in Column 7. The required size of the vent pipe given in Column 8 is the larger of those given in Columns 5 and 7.

The continuous vent, UW, serves two fixtures with a total of nine fixture units since the water closet is wet vented. As the water

closet has a 3-in. trap, Article 7.5.5.1. requires that the continuous vent have a minimum size of 1½ in. Note that this also applies to continuous vent E<sub>2</sub>C<sub>2</sub>.

A 3-in. diameter pipe drains to the sump, hence, according to Article 7.5.5.6., the minimum size of the sump vent is 2½ in. Since the branch vent, E<sub>1</sub>U<sub>1</sub>, and the vent stack, N<sub>1</sub>C<sub>1</sub>, form part of the sump vent, they must also have a minimum diameter of 2½ in.

Since the 2-in. soil-or-waste stack rises more than 25 ft, Article 7.5.2.4. requires that header, ST, and stack vent, TH<sub>2</sub>G<sub>3</sub>, have a minimum diameter of 2 in. Note that the developed length used to determine the size of the header is different from that used to determine the size of the stack vent.

## SECTION 7.6 POTABLE WATER SYSTEM

### SUBSECTION 7.6.1. ARRANGEMENT OF PIPING

Hot and cold faucets

**7.6.1.1.** Every *fixture* supplied with separate hot and cold water controls shall have the hot water control on the left and the cold on the right.

Drainage of piping

**7.6.1.2.(1)** Piping, except a *water service pipe*, shall be graded or pitched so that any part of the system can be drained, and if it is not practicable to avoid a *trap* or a sag in a pipe, provision shall be made to drain it.

(2) Where a drain valve is installed it shall be adequate to drain completely the piping that it serves.

Shut-off valve and drip valve

**7.6.1.3.(1)** Every *water service pipe* shall be provided with a shut-off valve and a drip valve, except that a stop-and-waste cock may be installed when the *diameter* of the pipe is 1 in. (25 mm) or less.

(2) The valve or cock described in Sentence (1) shall be located at the inner side of the wall or floor through which the pipe enters the *building*.

Check valve

**7.6.1.4.** Where polyethylene pipe is used for a *water service pipe*, a check valve shall be installed at the *building* end of the pipe.

Valve on riser

**7.6.1.5.** Except for a single-family house, every pipe that extends through more than one *storey* shall be provided with a shut-off valve at the source of supply to the riser.

Shut-off valve for water closet

**7.6.1.6.** The supply to every water closet shall be provided with a shut-off valve.

Shut-off valve for dwelling unit or suite

**7.6.1.7.** Except for a single-family house, shut-off valves shall be installed in a *dwelling unit* or in a suite in a motel or hotel as may be necessary to ensure that when the supply to one *dwelling unit* or suite is shut off the supply to the rest of the *building* is not interrupted. Alternatively, shut-off valves may be installed for every *fixture*.

Shut-off valves for other buildings

**7.6.1.8.** Except for a *dwelling unit*, motel or hotel, the supply to every *fixture* or device shall be provided with a shut-off valve except that one shut-off valve may control the supply to a group of *fixtures* that are in the same room.

Shut-off valves for water tank

**7.6.1.9.** Every pipe that is supplied from a water tank shall be provided with a shut-off valve located close to the tank.

**7.6.1.10.** Every pipe that supplies a hot water tank shall be provided with a shut-off valve.

**7.6.1.11.(1)** Every *water system* shall be protected against freezing.

(2) Every pipe that passes through an exterior wall to supply water to the exterior of the *building* shall be provided with a frost-proof hydrant or a stop-and-waste cock located inside the *building* and close to the wall.

**7.6.1.12.(1)** In addition to the requirements in Sentence (2), every hot water tank of a *storage-type service water heater* shall be equipped with a pressure relief valve designed to open when the water pressure in the tank reaches the rated working pressure of the tank and so located that the pressure in the tank shall not exceed the pressure at the relief valve by more than 5 psi under any condition of flow within the distribution system.

(2) Every hot water tank of a *storage-type service water heater* shall be equipped with

(a) a temperature relief valve with a temperature sensing element located within the top 6 in. (152 mm) of the tank and designed to open and discharge sufficient water from the tank to keep the maximum temperature of the water in the tank at 210 deg. F. (99°C) under all operating conditions, or

(b) a device that

(i) is designed to shut off the supply of electricity or fuel to the tank,

(ii) is not connected to and operates independent of the thermostatic control that determines the temperature of the water in the tank, and

(iii) is located and maintained on or within the top 6 in. (152 mm) of the tank so that the maximum temperature of the water in the tank shall not exceed 210 deg. F. (99°C) under all operating conditions.

(3) Every tank equipped as specified in Clause 7.6.1.12.(2)(b) shall bear the information in a clearly visible location that it is so equipped.

(4) A pressure relief valve and a temperature relief valve may be combined where Sentences (1) and (2) are complied with.

(5) Every pipe that conveys water from a temperature relief, pressure relief or a combined temperature and pressure relief valve which is installed on a hot water tank shall

(a) have a *diameter* equal to or greater than the *diameter* of the outlet of the valve, and

(b) terminate above a floor drain, *sump* or *fixture* or other *approved safe location*.

Clause 7.4.4.1.(1)(c) requires that the relief valve outlet be terminated above a receptacle draining to open air or within 1 ft of a floor sloping to a floor drain, and Sentence 7.4.4.2.(1) requires that the relief valve be indirectly connected.

(6) No shut-off valve shall be installed on the pipe between the tank and the relief valves.

Stop-and-waste cock for exterior supply

Pressure relief valve for storage type service water heater

Temperature relief valve

Temperature limit control

Combination pressure and temperature relief valve

Relief valve pipe discharge



**Back-siphonage device** (7) A *back-siphonage* device shall be installed when required by the authority having jurisdiction.

Articles 7.6.2.3. to 7.6.2.6. give methods of meeting this requirement.

**Accessibility** 7.6.1.13. Every valve shall be readily accessible for service or replacement.

**Shock stops** 7.6.1.14. Air chambers or shock stops shall be installed in conjunction with spring-action or quick-closing valves and taps to prevent water hammer. Shock stops that are of a mechanical nature shall be located in an accessible place.

#### **SUBSECTION 7.6.2. PROTECTION FROM CONTAMINATION**

**Connection of system** 7.6.2.1.(1) No part of a *potable water system* shall be connected so that foreign matter or non-*potable* water may enter, except that a water treatment device or apparatus may be installed with the written permission of the health authority having jurisdiction.

(2) No private water supply shall be interconnected with a public water supply system.

(3) No *potable* water pipe shall be connected to an ejector unless provided with an *approved vacuum breaker*.

(4) Aspirators shall not be *directly connected* to a *waste pipe* that is connected to a sewer but may be connected to the inlet side of a *trap* and shall be equipped with an *approved vacuum breaker* installed at least 6 in. (152 mm) above the aspirator unit. The aspirator unit shall be designed to provide for free flow discharge through an *air gap*. The length of the discharge pipe or tube from the aspirator shall at no time exceed 12 in. (305 mm).

(5) No water operated equipment shall be installed and no foreign chemical or substance that may cause pollution shall be used in a *potable* water supply, except that such equipment may be permitted by the authority having jurisdiction when equipped with an *approved backflow preventer*. The use of an *approved* assembly of differential valves and check valves including an automatically opened spillage port to the atmosphere designed to prevent *backflow* is permitted in installations where it is desirable to zone or isolate a multiple of openings or connections.

Examples of equipment to which this requirement applies are a water boiler (domestic or industrial) to which chemicals are added, or to a sprinkler system to which antifreeze may be added.

To be effective, every device installed in a potable water system for protection against backflow must be maintained in good working condition.

See Fig. 2, p. 2, for an illustration of a back-siphonage preventer (vacuum breaker), and Fig. 3, p. 3, for illustrations of backflow preventers.

**Cleaning of system** 7.6.2.2. A newly installed part of a *water system* shall be thoroughly cleaned to ensure freedom from contamination before the system is put into operation.

**Air gap or back siphonage preventer** 7.6.2.3.(1) Except for a *fixture* in which the water surface may be exposed to a pressure greater than atmospheric, a water supply inlet including a float-operated inlet shall be

- (a) located so as to provide an *air gap*, or
- (b) provided with a *back-siphonage preventer*.

(2) Except as provided in Sentence (3), an *air gap* shall be provided above, or a *back-siphonage preventer* installed so that its *critical level* is above, the *flood level rim* of the *fixture*.

(3) In a tank or vat an *air gap* may be provided above, or a *back-siphonage preventer* installed so that its *critical level* is above, the maximum water level in the tank or vat where the tank or vat is provided with an overflow that can, when all other inlets are open and the outlet is closed, maintain the water level at a distance above the top of the overflow that does not exceed

- (a) one-half the required *air gap* where an *air gap* is provided, or
- (b) the size of the inlet where a *back-siphonage preventer* is installed.

See Fig. 76, p. 98, for illustration of the use of nonpressurized fixtures, and Fig. 2, p. 2, for an illustration of a back-siphonage preventer.

7.6.2.4.(1) The height of every *air gap* shall be

Height of  
air gap

- (a) not less than twice the *diameter* of the *effective opening* of the water supply inlet except that where the inlet is located so that its inside edge is
  - (i) within three times the *diameter* of the *effective opening* from vertical surface, or
  - (ii) within four times the *diameter* of the *effective opening* from each of two adjacent vertical surfaces,

the height of the *air gap* shall be not less than three times the *diameter* of the *effective opening*, and
- (b) not less than 1 in. (25 mm) where the *fixture* is other than a drinking fountain, or
- (c) not less than ¾ in. (19 mm) where the *fixture* is a drinking fountain.

Where the inlet is located as shown in Fig. 75, the height of the *air gap* shall be not less than three times the *diameter* of the *effective opening*.

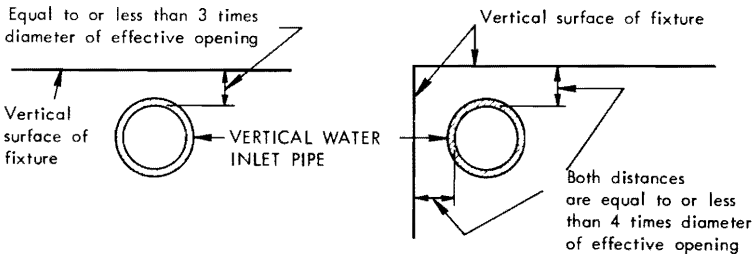
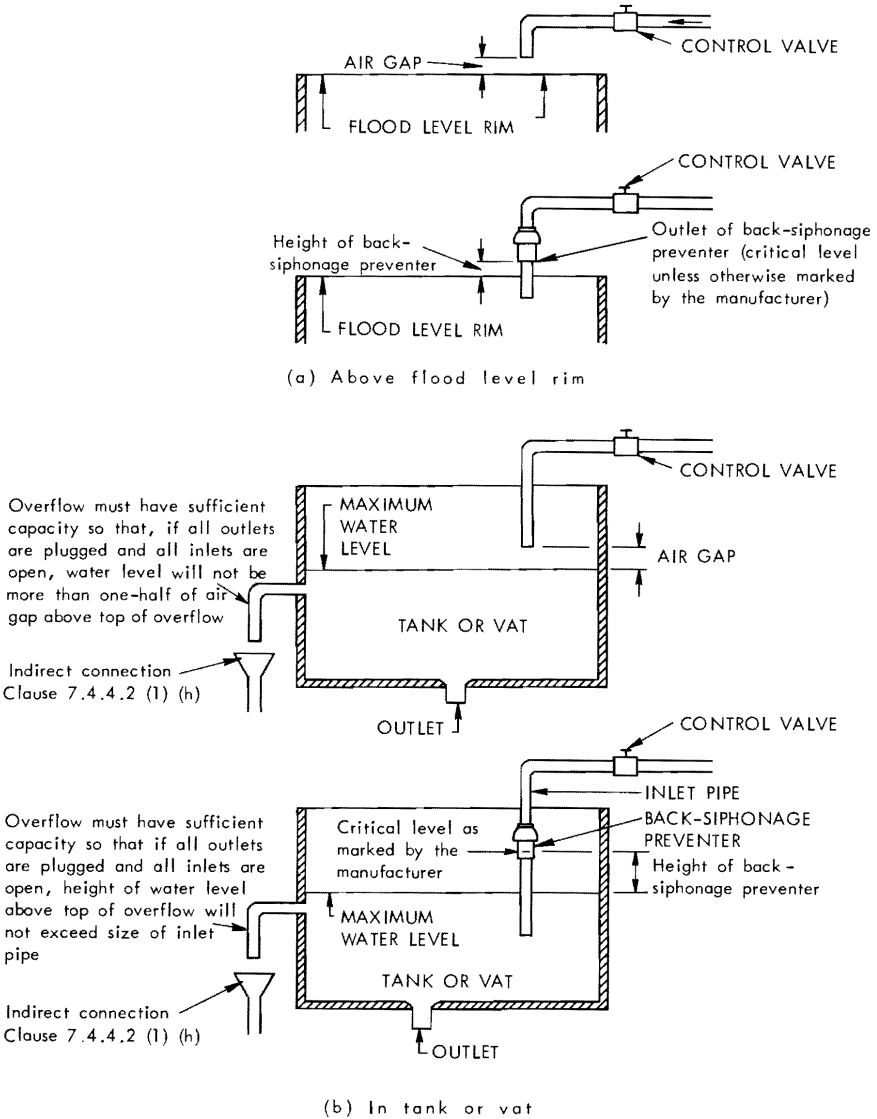

Figure 75 Height of air gap

**Height of back-siphonage preventer**

- 7.6.2.5.(1) The height at which the critical level of a back-siphonage preventer is installed above a flood level rim or maximum water level shall be**
- (a) not less than four times the diameter of the inlet of the fixture control valve or faucet, and
  - (b) not less than 4 in. (102 mm) where the back-siphonage preventer is installed in other than a water closet tank, or



**Figure 76** Installation of air gaps and back-siphonage preventers

(c) not less than 1 in. (25 mm) where the *back-siphonage preventer* is installed in a water closet tank.

(2) Where the *critical level* is not marked on a *back-siphonage preventer* the outlet of the *back-siphonage preventer* shall be assumed to be its *critical level*.

7.6.2.6. Where a *back-siphonage preventer* is installed it shall be located on the downstream side of the *fixture control valve* or faucet so that it will be subject to pressure only when the valve or faucet is open.

Location of  
back-siphon-  
age preventer

See Fig. 76.

7.6.2.7. Where a water supply pipe is connected to a device which may be subjected to a pressure in excess of atmospheric, the pipe shall be protected with an assembly of differential valves and check valves including an automatically opened spillage port to the atmosphere designed to prevent *back-flow*.

Protection of  
device under  
pressure

An example of a device that meets this requirement is shown in Fig. 3, p. 3. See also Article 7.6.2.1. regarding the protection of potable water systems from contamination.

### SUBSECTION 7.6.3. TANKS

7.6.3.1. Every tank shall be supported independent of the piping that is connected to it.

Support of  
tank

7.6.3.2. Every tank that is not under pressure shall

Protection  
of non-  
pressurized  
tank

(a) not be located under drainage or non-*potable* water piping.

(b) be provided with a cover that prevents the entrance of foreign matter, and

(c) be provided with an overflow pipe that will prevent flooding when all inlets to the tank are open and all outlets except the overflow are closed.

7.6.3.3. A cover of a tank that is under pressure shall not be located under drainage or non-*potable* water piping.

Protection of  
pressurized  
tank

### SUBSECTION 7.6.4. WELLS

7.6.4.1. Every well shall be constructed so that the well water is protected against surface water contamination or other pollutants.

### SUBSECTION 7.6.5. SIZE AND CAPACITY OF PIPES

This Subsection contains performance requirements for water systems. Two widely used references for the design of water systems are:

“Water-Distributing Systems for Buildings” by R. B. Hunter, Building Materials and Structures Report BMS 79, United

States Department of Commerce, National Bureau of Standards, Washington, D.C., 1941; and

"National Plumbing Code Handbook" edited by V. T. Manas, McGraw-Hill Book Company, New York, U.S.A. 1957.

**Fixture supply pipe** 7.6.5.1.(1) Except as provided in Sentence (2), the *diameter* of a pipe that supplies a *fixture* or device shall conform to Table 7.6.5.A.

(2) A tail piece or connector not more than 30 in. (762 mm) in length and not less than ¼ in. (6 mm) inside *diameter* may be used.

Table 7.6.5.A.  
Forming Part of Sentence 7.6.5.1.(1)

<i>Fixture or Device</i>	<i>Minimum Diameter of Supply Pipe, in.</i>
Bath tub	½
Combination sink and tray	½
Drinking fountain	⅜
Dishwasher, domestic	½
Kitchen sink, domestic	½
Kitchen sink, commercial	¾
Lavatory	⅜
Laundry tray: 1, 2, or 3 compartments	½
Shower, single head	½
Sink, service, slop	½
Sink, flushing rim	¾
Urinal, flush tank	½
Urinal, direct flush valve	¾
Water closet, flush valve type	1
Water closet, tank type	⅜
Hose bib	½
Wall hydrant	½
Column 1	Column 2

**Capacity of system and piping**

7.6.5.2.(1) The capacity of every *potable water system* shall be sufficient to provide a positive pressure at every supply opening.

(2) Every *water service pipe* shall have a capacity not less than the peak demand flow and a *diameter* not less than ¾ in. (19 mm).

(3) The capacity of every pipe that supplies a *fixture* shall be not less than the flow that will flush the *fixture* and keep it in a sanitary condition.

(4) Pressure reducing valves may be required by the *authority having jurisdiction* when the water pressure exceeds 100 psi.

## SECTION 7.7 NON-POTABLE WATER SYSTEM

### SUBSECTION 7.7.1. CONNECTION

**7.7.1.1.** A *non-potable water system* shall not be connected to a *potable water system*.

### SUBSECTION 7.7.2. IDENTIFICATION

**7.7.2.1.** *Non-potable water piping* shall be identified by markings that are permanent, distinct and easily recognized.

### SUBSECTION 7.7.3. LOCATION

**7.7.3.1.** *Non-potable water piping* shall not be located

- (a) where food is prepared in a food processing plant,
- (b) above food-handling equipment,
- (c) above a non-pressurized *potable water tank*, or
- (d) above a cover of a pressurized *potable water tank*.

Location of  
pipe

**7.7.3.2.** An outlet from a *non-potable water system* shall not be located where it can discharge into

- (a) a sink or washbasin,
- (b) a *fixture* into which an outlet from a *potable water system* is discharged, or
- (c) a *fixture* that is used for a purpose related to the preparation, handling or dispensing of food, drink, or products that are intended for human consumption.

Location of  
outlet

## APPENDIX A

### Part 1 Administration

National Building Code of Canada 1970

BYLAW NUMBER .....

†WHEREAS The ..... Act provides that a Municipal Council may by Bylaw regulate the erection and provide for the safety of buildings.

THEREFORE the Municipal Council of the Corporation of the ..... of ..... enacts as follows:

### PART 1 ADMINISTRATION

#### SECTION 1.1 SHORT TITLE

SUBSECTION 1.1.1. This Bylaw may be cited as "The Building Bylaw."

#### SECTION 1.2 PURPOSE

SUBSECTION 1.2.1. It is the purpose of this Bylaw to safeguard life or limb, health, property and public welfare with respect to the design, construction and *alteration of buildings\** by the provision of appropriate minimum standards.

#### SECTION 1.3 SCOPE

SUBSECTION 1.3.1. Parts 1, 2, 5, 7 and 8 of this Bylaw apply to all *buildings*.

SUBSECTION 1.3.2. Parts 3, 4 and 6 of this Bylaw apply to:

- (a) all *buildings* used for *Assembly, Institutional, and High Hazard Industrial Occupancies*,
- (b) all *buildings* exceeding 6000 square feet (558 square metres) in *build-*

†This preamble relates the Bylaw to enabling legislation and should be adjusted to conform to the powers delegated to the Municipality.

\*Words that appear in italics are defined in Part 2 of this Bylaw.

*ing area or exceeding 3 storeys in building height used for Residential Business and Personal Services, Mercantile and Medium and Low Hazard Industrial Occupancies.*

**SUBSECTION 1.3.3.** Part 9 of this Bylaw applies to *buildings 3 storeys or less in height, having a building area not exceeding 6000 square feet (558 square meters) and which are used for Residential, Business and Personal Service, Mercantile, and Medium and Low Hazard Industrial Occupancies.*

**SUBSECTION 1.3.4.** This Bylaw does not apply to farm *buildings* other than those used as residences.

(The Canadian Code for Farm Buildings also issued by the Associate Committee on the National Building Code provides standards and other useful information for these special farm buildings and is based on elements of the National Building Code.)

## **SECTION 1.4 APPLICATION**

**SUBSECTION 1.4.1.** The application of this Bylaw shall be in accordance with Subsections 1.4.2. to 1.4.7. inclusive subject in every case to the over-all limitations set out in Section 1.3.

**SUBSECTION 1.4.2.** When a *building* is built, this Bylaw applies to the design and construction of the *building*.

**SUBSECTION 1.4.3.** When the whole or any part of a *building* is demolished this Bylaw applies to any part remaining and to the work involved in the demolition.

**SUBSECTION 1.4.4.** When the whole or any part of a *building* is moved either within or into a municipality this Bylaw applies to all parts of the *building*.

**SUBSECTION 1.4.5.** When a *building* is altered this Bylaw applies to the whole *building* except that the Bylaw may apply only to part of the *building* if that part is completely self-contained with respect to the facilities and safety measures required by this Bylaw.

**SUBSECTION 1.4.6.** When the *occupancy* of a *building* is changed this Bylaw applies to all parts of the *building* affected by the change.

**SUBSECTION 1.4.7.** When materials and equipment regulated by this Bylaw are replaced or altered in a *building* this Bylaw applies to all such replacements and *alterations*.

## **SECTION 1.5 PROHIBITION**

**SUBSECTION 1.5.1.** No part of the work referred to in Section 1.4 for which part a *permit* is required by this Bylaw, shall be started or continued unless the *owner* has obtained a *building permit* to carry out that part of the work.

**SUBSECTION 1.5.2.** No part of the work referred to in Section 1.4 in re-



spect of which a *permit* is required under any other Bylaw shall be started or continued unless the *owner* has obtained a *permit* under that Bylaw.

## SECTION 1.6 REFERENCED DOCUMENTS

**SUBSECTION 1.6.1.** When detailed technical information regarding materials, equipment and methods of structural design is necessary to ensure their compliance with the performance requirements of this Bylaw reference is made in the text to the specific edition of an appropriate technical standard issued by a recognized standards organization. This Bylaw therefore includes as a part of its provisions these referenced documents to the extent that they relate to *buildings*.

**SUBSECTION 1.6.2.** In the case of any conflict between the provisions of this Bylaw and those of any referenced document the provisions of this Bylaw will always take precedence. Provincial regulations respecting *building* take precedence over this Bylaw.

**Note:** Supplements 1, 2, 3, 4 and 5 which are published in association with this Bylaw contain technical information that will assist in the effective use of these regulations but they do not constitute a part of the Bylaw.

## SECTION 1.7 DUTIES OF THE AUTHORITY HAVING JURISDICTION

**SUBSECTION 1.7.1.** The *authority having jurisdiction* shall

- (a) administer this Bylaw, and
- (b) keep records of all applications received, *permits* and orders issued, inspections and tests made, and shall retain copies of all papers and documents connected with the administration of this Bylaw, which will form part of the public records.

## SECTION 1.8 POWERS OF THE AUTHORITY HAVING JURISDICTION

**SUBSECTION 1.8.1.** The *authority having jurisdiction* may

- (a) enter any *building* or premises at any reasonable time for the purpose of administering or enforcing this Bylaw;
- (b) cause a written notice to be delivered to the *owner* of any property directing him to correct any condition where, in the opinion of the *authority having jurisdiction*, that condition constitutes a violation of this Bylaw;
- (c) order the *owner* to stop work on the *building* if it is proceeding in contravention of this Bylaw or if it is deemed to be in an unsafe condition;

- (d) direct that tests of materials, devices, construction methods, structural assemblies or foundation conditions be made, or sufficient evidence or proof be submitted, at the expense of the *owner*, where such evidence or proof is necessary to determine whether the material, device, construction or foundation condition meets the requirements of this Bylaw;
- (e) revoke or refuse to issue a *permit* where in its opinion the results of tests referred to in Clause (d) are not satisfactory;
- (f) order the removal of any *building* erected or placed in violation of this Bylaw.

## SECTION 1.9 PERMITS

SUBSECTION 1.9.1. Subject to Subsections 1.9.2. and 1.9.4. and Clause 1.8.1.(d), where

- (a) an application has been made, and
- (b) the proposed work set out in the application conforms with this Bylaw and all other applicable Bylaws,

the *authority having jurisdiction* shall issue the *permit* for which the application is made.

SUBSECTION 1.9.2. Every *permit* is issued upon

- (a) the condition that construction is to be started within 6 months from the date of issuing the *permit*;
- (b) the condition that construction is not to be discontinued or suspended for a period of more than one year.

SUBSECTION 1.9.3. The application referred to in Subsection 1.9.1. shall

- (a) be made in the form prescribed by the *authority having jurisdiction*;
- (b) be signed by the applicant;
- (c) state the intended use of the *building*;
- (d) include copies in duplicate of the specifications and scale drawings of the *building* with respect to which the work is to be carried out showing
  - (i) the dimensions of the *building*,
  - (ii) the proposed use of each room or *floor area*,
  - (iii) the dimensions of the land on which the *building* is, or is to be, situated,
  - (iv) the grades of the *streets* and sewers abutting the land referred to in Subclause (iii),
  - (v) the position, height and horizontal dimensions of all *buildings* on the land referred to in Subclause (iii),

- (vi) an up-to-date survey of the building site by a registered provincial surveyor,
  - (vii) the technical information specified in other Parts of this Bylaw required to be included on the drawings relating to those Parts, and
  - (viii) such other information as is necessary to illustrate all essential features of the design of the *building*; and
- (e) contain any and all other information necessary to establish compliance with this Bylaw or as required by the *authority having jurisdiction*.

**SUBSECTION 1.9.4.** The *authority having jurisdiction* may revoke a *permit* where there is a violation of:

- (a) any condition under which the *permit* was issued, or
- (b) any provision of this Bylaw.

## **SECTION 1.10 RESPONSIBILITY OF THE OWNER**

**SUBSECTION 1.10.1.** Neither the granting of a *permit* nor the approval of the drawings and specifications nor inspections made by the *authority having jurisdiction* shall in any way relieve the *owner* of such *building* from full responsibility for carrying out the work or having the work carried out in accordance with the requirements of this Bylaw. No work shall be started before the issue of the necessary *permit* referred to in Subsection 1.9.1.

## **SECTION 1.11 DUTIES OF THE OWNER**

**SUBSECTION 1.11.1.** Every *owner* of property shall:

- (a) permit the *authority having jurisdiction* to enter any *building* or premises at any reasonable time for the purpose of administering or enforcing this Bylaw;
- (b) obtain, where applicable, from the appropriate *authority having jurisdiction*, *permits* relating to *building*, zoning, grades, sewers, water mains, plumbing, signs, blasting, street occupancy, electricity, highways, and all other *permits* required in connection with the proposed work;
- (c) give at least 48 hours' notice to the *authority having jurisdiction* of the intention to start work on the building site;
- (d) give notice to the *authority having jurisdiction*
  - (i) at least 24 hours before a foundation wall below ground level is to be placed and before any backfilling of the excavation is to be carried out, and
  - (ii) as may otherwise be required by this Bylaw;

- (e) give written notice to the *authority having jurisdiction* within 30 days of completion of the work described in the *permit*; and
- (f) obtain an *occupancy permit* from the *authority having jurisdiction* prior to any
  - (i) *occupancy* of a *building* or part thereof after construction, wrecking or alteration of that *building* or part, or
  - (ii) change in the class of *occupancy* of any *building* or part thereof.

**SUBSECTION 1.11.2.** Where tests of any materials are made to ensure conformity with the requirements of this Bylaw, records of the test results shall be kept available for inspection during the construction of the *building* and for such a period thereafter as required by the *authority having jurisdiction*.

## **SECTION 1.12 DOCUMENTS ON THE SITE**

**SUBSECTION 1.12.1.** The *owner* to whom a *permit* is issued shall, during construction, keep

- (a) posted in a conspicuous place on the property in respect of which the *permit* was issued a copy of the *building permit* or a poster or placard in lieu thereof, and
- (b) a copy of the *approved* drawings and specifications referred to in Clause 1.9.3.(d) on the property in respect of which the *permit* was issued.

## **SECTION 1.13 EQUIVALENTS**

**SUBSECTION 1.13.1.** The provisions of this Bylaw are not intended to limit the appropriate use of materials, equipment or methods of construction not specifically authorized herein. Any *owner* desirous of providing an equivalent for one or more of the regulations of this Bylaw shall submit to the *authority having jurisdiction* sufficient evidence to satisfy the appropriate authority that the proposed equivalent will provide the level of performance required by this Bylaw.

## **SECTION 1.14 TESTS**

**SUBSECTION 1.14.1.** To the extent that is possible all tests required by the *authority having jurisdiction* shall be carried out in accordance with recognized standard test methods. In the absence of such standard test methods the *authority having jurisdiction* may specify the test procedure to be followed. Copies of the results of all such tests shall be retained by the *authority having jurisdiction* after construction is complete and shall form part of the public records.

## SECTION 1.15 BOARD OF APPEAL

**SUBSECTION 1.15.1.** A Board of Appeal may be appointed by the *authority having jurisdiction* to:

- (a) hear appeals from any ruling or direction by the *authority having jurisdiction* pursuant to the provisions of this Bylaw, or
- (b) decide if materials and types of construction other than those required by this Bylaw are equivalent thereto.

**SUBSECTION 1.15.2.** An appeal against the ruling or direction of the *authority having jurisdiction* may be submitted to the Board of Appeal by a person who,

- (a) has applied under the provisions of this Bylaw for a *permit* which has not been granted,
- (b) has had a building *permit* revoked, or
- (c) feels himself adversely affected by a decision of the *authority having jurisdiction*.

## SECTION 1.16 PENALTIES

**SUBSECTION 1.16.1.** Any person who violates any provision of this Bylaw is guilty of an offence and is liable, on summary conviction to a fine of not less than \$ . . . . . and not exceeding \$ . . . . .

## SECTION 1.17 EFFECTIVE DATE

**SUBSECTION 1.17.1.** This Bylaw shall come into effect . . . . . days after passing and where required after approval by the appropriate provincial authority. Any work carried out under the terms of this Bylaw after its approval but before its effective date must comply in every respect with this Bylaw.

## SECTION 1.18 CLIMATIC DATA

**SUBSECTION 1.18.1.** When climatic data are required for the design of *buildings* in this municipality, they shall be the data provided by Table 1.18.1.A. when the appropriate climatic figures have been entered by the *authority having jurisdiction*.

Table 1.18.1.A.

Forming part of Subsection 1.18.1.

**CLIMATIC DATA FOR THE  
MUNICIPALITY OF \_\_\_\_\_**

	<b>Apply to Code Requirement</b>
1. January 2½ per cent Design Temperature (°F.) .....	_____ 6.2.3.2.
2. January 1 per cent Design Temperature (°F.) .....	_____ 6.2.3.2.
3. July 2½ per cent Design Drybulb Temp. (°F.) .....	_____ 6.2.3.2.
4. July 2½ per cent Design Wetbulb Temp. (°F.) .....	_____ 6.2.3.2.
5. Annual Total Degree-days below 65° F. ...	_____
6. Maximum Fifteen-minute Rainfall (in.) ...	_____ 7.4.11.5.
7. Maximum One-day Rainfall (in.) .....	_____ 4.1.5.5.(1)
8. Annual Total Precipitation (in.) .....	_____
9. Maximum Snow Load on the Ground (lb. per sq. ft.) .....	_____ 4.1.5.1.
10. Wind Effects: Probability 1/10 .....	_____ 4.1.6.1.(3)
Probability 1/30 .....	_____ 4.1.6.1.(3)
Probability 1/100 .....	_____ 4.1.6.1.(3)
11. Earthquake R-factor .....	_____ 4.1.7.1.(4)

**Note:** The above Table has been provided for recording the values of major climate factors that affect building for each municipality using the Code. These values may be obtained for any municipality from Supplement No. 1 to the National Building Code or by writing to the Secretary, Associate Committee on the National Building Code, c/o the National Research Council, Ottawa, Canada.

## APPENDIX B

### Excerpts from Part 3: Use and Occupancy

#### National Building Code of Canada 1970

##### SUBSECTION 3.1.2. CLASSIFICATION OF BUILDINGS OR PARTS OF BUILDINGS BY MAJOR OCCUPANCY

3.1.2.1.(1) Every *building* or part thereof shall be classified by the *authority having jurisdiction* as belonging to one of the Groups or Divisions listed in the following clauses according to its *major occupancy* as described and exemplified in Table 3.1.2.A.:

Classification of buildings or parts thereof

- (a) Group A, *Assembly Occupancy*
  - (i) Division 1,
  - (ii) Division 2,
  - (iii) Division 3, or
  - (iv) Division 4;
- (b) Group B, *Institutional Occupancy*
  - (i) Division 1, or
  - (ii) Division 2;
- (c) Group C, *Residential Occupancy*;
- (d) Group D, *Business and Personal Service Occupancy*;
- (e) Group E, *Mercantile Occupancy*; or
- (f) Group F, *Industrial Occupancy*
  - (i) Division 1,
  - (ii) Division 2, or
  - (iii) Division 3.

(2) The purpose of classification is to determine which requirements apply. This Bylaw requires classification in accordance with every *major occupancy* for which the *building* is used or intended to be used. This gives the *authority having jurisdiction* the right to enforce regulations for every such *occupancy*. Where necessary in this Part, an application clause has been inserted to explain how to choose between the alternate regulations which multiple *occupancy* classification may present.

(3) When it is intended to use a *building* for more than one *major occupancy*, the *building* shall be classified according to all *major occupancies* for which it is used or intended to be used.

(4) Any *building* may be deemed to be occupied by a single *major occupancy* notwithstanding its use for more than one *major occupancy* provided that such *occupancies* are classified as belonging to the same Group classification or, where the Group is divided into Divisions, the same Division classification in Table 3.1.2.A.

Buildings containing occupancies of same classification

(5) Arena-type *buildings* intended for occasional use for trade shows and similar exhibition purposes shall be classified as a Group E, *major occupancy*.

Other use of arena-type buildings

**Table 3.1.2.A.**  
**Forming Part of Article 3.1.2.1.**

<b>Classification by Group or Division of Typical Occupancies</b>			
<b>Group</b>	<b>Division</b>	<b>Description of Occupancies</b>	<b>Examples</b>
<b>A</b>	<b>1</b>	<i>Assembly occupancies intended for the production and viewing of the performing arts, including:</i>	<b>Motion picture theatres Opera houses Television studios admitting a viewing audience Theatres, including experimental theatres</b>
<b>A</b>	<b>2</b>	<i>Assembly occupancies not elsewhere classified in Group A, including:</i>	<b>Art galleries Auditoria Bowling alleys Churches and similar places of worship Clubs, nonresidential Community halls Court rooms Dance halls Exhibition halls (other than classified in Group E) Gymnasia Indoor swimming pools Lecture halls Libraries Licensed beverage establishments Lodge rooms Museums Passenger stations and depots Recreational piers Restaurants Schools and colleges, nonresidential Undertaking premises</b>
<b>A</b>	<b>3</b>	<i>Arena-type occupancies<sup>(1)</sup>, including:</i>	<b>Arenas Armouries Ice rinks Indoor swimming pools with spectator seating</b>
<b>A</b>	<b>4</b>	<i>Assembly occupancies in which provision is made for the congregation or gathering of persons for the purpose of participating in or viewing open air activities, including:</i>	<b>Amusement park structures (not elsewhere classified) Bleachers Grandstands Reviewing stands Stadia</b>
<b>B</b>	<b>1</b>	<i>Occupancies in which persons are detained for penal or correctional purposes or for involuntary detention or whose liberties are restricted, including:</i>	<b>Jails Penitentiaries Police stations<sup>(2)</sup> Prisons Psychiatric hospitals<sup>(2)</sup> Reformatories<sup>(2)</sup></b>



Table 3.1.2.A. (cont'd)

Classification by Group or Division of Typical <i>Occupancies</i>			
Group	Division	Description of <i>Occupancies</i>	Examples
B	2	<i>Occupancies in which persons because of age, mental, or physical limitations require special care or treatment, including:</i>	Children's custodial homes Convalescent homes Homes for the aged Hospitals Infirmaries Orphanages Psychiatric hospitals <sup>(3)</sup> Reformatories <sup>(3)</sup> Sanitoria <sup>(3)</sup>
C		<i>Occupancies used for sleeping accommodation excluding those covered in Group B, Institutional Occupancies, including:</i>	Apartments Boarding houses Clubs, residential Colleges, residential Convents Dormitories Hotels Houses Lodging houses Monasteries Motels Schools, residential
D		<i>Occupancies for conducting business and the rendering of professional and personal services, including:</i>	Banks Barber and hair-dressing shops Beauty parlours Dental offices Dry-cleaning, self-service not employing flammable or explosive solvents or cleaners Fire stations Laundry, self-service Medical offices Offices Police stations <sup>(3)</sup> Radio stations Small tool and appliance rental and service Telephone exchanges
E		<i>Occupancies for the displaying, or selling of retail goods, wares or merchandise, including:</i>	Department stores Exhibition halls Markets Shops Stores Supermarkets
F	1	<i>Occupancies involving sufficient quantities of highly combustible and flammable or explosive materials which because of their inherent characteristics constitute a special fire hazard, including:</i>	Bulk plants for flammable liquids Bulk storage warehouse for hazardous substances Cereal mills <sup>(4)</sup> Chemical manufacturing or processing plants <sup>(4)</sup> Distilleries <sup>(4)</sup> Dry cleaning plants Feed mills <sup>(4)</sup> Flour mills <sup>(4)</sup> Grain elevators <sup>(4)</sup> Lacquer factories Mattress factories Paint, varnish and pyroxylin product factories Rubber processing plants Spray painting operation Waste paper processing plants

Table 3.1.2.A. (cont'd)

Classification by Group or Division of Typical Occupancies			
Group	Division	Description of Occupancies	Examples
F	2	Occupancies in which the combustible content is more than 10 lb or 100,000 Btu's per square foot of floor area and not classified in Division F1 of this Group, including:	<p>Aircraft hangars            Box factories            Candy plants            Cold storage plants            Dry cleaning plants not using flammable or explosive solvents or cleaners            Electrical substations            Factories            Freight depots            Helicopter landing areas on roofs            Laboratories            Laundries except self-service</p> <p>Mattress factories            Planing mills            Printing plants            Repair garages            Salesrooms            Service stations            Storage rooms            Television studios not admitting a viewing audience            Warehouses            Wholesale rooms            Woodworking factories            Workshops</p>
F	3	Occupancies in which the combustible content is not more than 10 lb or 100,000 Btu's per square foot of floor area, including:	<p>Creameries            Factories            Laboratories            Power plants            Sales rooms            Sample display rooms</p> <p>Storage garages including open air parking garages            Storage rooms            Warehouses            Workshops</p>
Col. 1	2	3	4

## Notes to Table 3.1.2.A:

- (1) See Sentence 3.1.2.1.(5).
- (2) With detention quarters.
- (3) Without detention quarters.
- (4) See Sentence 3.2.2.1.(2).

**3.1.7.6.(1) Openings for *noncombustible* pipes are permitted in *fire separations* provided such pipes**

**Openings for pipes and ducts**

- (a) are enclosed in shafts conforming to Section 3.5, or
- (b) are tightly fitted or *fire stopped* to prevent the passage of smoke and flame.

**(2) Openings for *noncombustible* ducts are permitted through *fire separations* provided such ducts**

- (a) are enclosed in shafts, conforming to Section 3.5, or
- (b) conform to Subsection 3.5.1. for unenclosed ducts and they are tightly fitted or *fire stopped* to prevent the passage of smoke and flame.

**3.1.7.7. Every pipe, duct, electrical outlet box, or other similar service equipment, partially or wholly penetrating through a *fire separation*, shall be of *noncombustible* materials unless such service equipment has been incorporated in an assembly at the time of testing in conformance with Sentence 3.1.5.1.(1).**

**Service equipment penetrating fire separations**

**3.1.9.1.(9) Where *fire stops* are pierced by pipes, ducts or other elements or assemblies, the integrity of the *fire stop* shall be maintained.**

**SUBSECTION 3.1.14. OCCUPANT LOAD**

**3.1.14.1.(1) The *occupant load* of every *floor area*, or part thereof, shall be**

- (a) the number of persons for which the *floor area* or part thereof is designed, but
- (b) not less than the number of persons that can be accommodated on the *floor area* or part thereof as determined from Table 3.1.14.A.

**(2) For the purposes of this Article, *mezzanines*, tiers and balconies shall be regarded as part of the *floor area*.**

**(3) Where a room or group of rooms is intended for two or more *occupancies* at different times, the value to be used from Table 3.1.14.A. shall be the value which gives the greatest number of persons for the *occupancies* concerned.**

**SUBSECTION 3.6.4. PLUMBING FACILITIES**

**3.6.4.1.(1) Each *building* situated on property that abuts on a *street* in which a public or municipal water main is located shall be provided with or have accessible to its occupants a *plumbing system* including a *potable water supply*, a *sanitary drainage system* and toilet fixtures.**

**Systems required**

**(2) When the installation of a *sanitary drainage system* is not possible because of the absence of a water supply, sanitary privies, chemical closets or other *approved* means for the disposal of human waste shall be provided.**

**(3) *Plumbing systems* shall be designed and installed in accordance with Part 7 of this Bylaw.**

**3.6.4.2.(1) Water closets shall be provided for each sex in accordance with the anticipated proportion of each sex in the *occupancy* when this can be determined with reasonable accuracy except that when such a determination**

**Minimum number of fixtures**

**Table 3.1.14.A.  
Forming Part of Article 3.1.14.1.**

Item No.	Type of Use of <i>Floor Area</i> or Part Thereof	Area per Person, sq ft
	<b>Assembly uses</b>	
1	space with fixed seats	(1)
2	space with nonfixed seats	8
3	space with nonfixed seats and tables	10
4	standing space	4
5	stadia and grandstands	6
6	bowling alleys, pool and billiard rooms	100
7	classrooms	20
8	school shops and vocational rooms	100
9	reading or writing rooms or lounges	20
10	dining, beverage and cafeteria space	12
11	laboratories in schools	50
12	other assembly uses	15
	<b>Institutional uses</b>	
1	surgical and obstetrical suites	125
2	wards containing more than 2 beds	50
3	detention quarters	125
4	other institutional uses	100
	<b>Residential uses</b>	(2)
1	houses	see Part 9
2	dormitories	50
	<b>Business and Personal Service uses</b>	
1	personal service shops	50
2	other business and personal uses including offices	100
	<b>Mercantile uses</b>	
1	retail sales floors at ground, basement or cellar	30
2	other mercantile uses	60
	<b>Industrial uses</b>	
1	manufacturing or process rooms	50
2	storage garage	200
3	storage space (warehouse)	300
4	aircraft hangars	500
5	other industrial uses	100
	<b>Other uses</b>	
1	cleaning and repair of goods	50
2	kitchens	100
3	storage	500

Notes to Table 3.1.14.A.:

- (1) The occupant load shall be based on the number of seats provided.
- (2) The occupant load for dwelling units shall be based on 2 persons per bedroom or area provided for sleeping.

cannot be made with reasonable accuracy, it may be assumed that the *occupancy* is equally divided between the sexes.

(2) Where more than two water closets are required in this Subsection, urinals may be substituted for two thirds of the required number of water closets and may be counted as water closets.

(3) At least one washbasin shall be provided in a room containing one or two water closets or urinals, and at least one additional washbasin shall be provided for each additional two such fixtures.

(4) Except as provided in Sentences (5) and (6) the minimum number of water closets shall be determined from Table 3.6.4.A. for the *occupant load*

Table 3.6.4.A.  
Forming Part of Sentence 3.6.4.2.(4)

Type of Use of <i>Floor Area</i> or Room	Maximum Number of Persons per Water Closet	
	Male	Female
<b>Group A <i>Assembly Occupancies</i></b>		
1) space with fixed seats	150	75
2) space with non-fixed seats	300	150
3) space with non-fixed seats and tables	300	150
4) dance halls and recreational establishments	100	75
5) classrooms, primary and secondary	30	26
6) college <i>buildings</i> , non-residential	100	75
7) dining rooms and <i>restaurant</i>	100	50
8) establishments serving alcoholic beverages	(1)	(1)
9) all other <i>assembly occupancies</i>	(1)	(1)
<b>Group B <i>Institutional Occupancies</i></b>		
1) Division 1	(2)	(2)
2) Division 2	(1)	(1)
<b>Group C <i>Residential Occupancies</i></b>	(3)	(3)
<b>Group D <i>Business and Personal Service Occupancies</i></b>	(1)	(1)
<b>Group E <i>Mercantile Occupancies</i></b>	300 <sup>(4,5)</sup>	150 <sup>(4,5)</sup>
<b>Group F <i>Industrial Occupancies</i></b>	300 <sup>(4,5)</sup>	150 <sup>(4,5)</sup>
<b>Column 1</b>	<b>2</b>	<b>3</b>

Notes to Table 3.6.4.A.:

- (1) See Sentence 3.6.4.2.(7).
- (2) The maximum number of persons per water closet shall be determined by the *appropriate authority having jurisdiction*.
- (3) See Sentence 3.6.4.2.(8).
- (4) Facilities provided for employees may be counted as part of those required for the *occupancy* when such facilities are made accessible to the public.
- (5) Where the sum of the *floor areas*, excluding *basements* and *cellars*, is less than 5000 sq ft (465<sup>2</sup> m ) not more than one water closet need be provided.

of the *occupancy* calculated from Table 3.1.14.A. except that for Group D *occupancies* the *occupant load* shall be calculated by assuming a net area of 150 sq ft (14 m<sup>2</sup>) per person.

(5) Where mobile homes do not have individual sanitary facilities connected to a central water supply and drainage system, a service *building* shall be provided for public use and shall contain at least one water closet for each sex where the facilities serve not more than 10 mobile homes, and where the facilities serve more than 10 mobile homes, an additional water closet for each sex shall be provided for each additional 5 mobile homes.

(6) Where a service *building* is required by Sentence (5), it shall contain washbasins as required in Sentence (3) and at least

- (a) one laundry tray or similar facility, and
- (b) one bathtub or shower for each sex.

(7) The number of water closets for establishments serving alcoholic beverages and all other places of assembly not shown in Table 3.6.4.A., Group B, Division 2 *occupancies* and Group A *occupancies* shall conform to Table 3.6.4.B.

Table 3.6.4.B.

Forming Part of Sentence 3.6.4.2.(7)

Number of persons of each sex	Minimum number of water closets
up to 9	1
10 to 24	2
25 to 49	3
50 to 74	4
75 to 100	5
over 100	5 plus one for each additional 30 persons over 100

(8) Except for *dwelling units* the minimum number of water closets on each floor of a *residential occupancy* shall be one for each 10 bedrooms for each sex, excluding those rooms or suites of rooms with individual water closets. Plumbing systems and facilities for *dwelling units* shall conform to Part 9 of this Bylaw.

#### Privacy

3.6.4.3.(1) Every room containing sanitary facilities serving one sex only shall be enclosed by a full height door which shall be clearly marked to indicate the sex served.

(2) Rooms providing separate water closets for more than one male or female shall be designed so that the water closets and urinals are not visible when the doors to such rooms open onto a place where persons of the other sex work or pass.

(3) Where more than one water closet, washbasin, bathtub or shower is installed in a room, the room shall serve one sex only.

## APPENDIX C

### Excerpts from Part 5: Materials

#### National Building Code of Canada 1970

(The listing of standards includes only those relevant to plumbing)

#### Abbreviations Used

The following abbreviations shall apply in referring to the source of standards listed in this Part.

Canadian Standards Association, Rexdale, Ontario .....	CSA
Canadian Government Specifications Board, Ottawa, Ontario .....	CGSB
Underwriters' Laboratories of Canada, Scarborough, Ontario .....	ULC
<hr/>	
American National Standards Institute, New York, N.Y., U.S.A. ....	ANSI
American Society for Testing and Materials, Philadelphia, Pa., U.S.A. ....	ASTM
Federal Specifications and Standards, General Services Administration, Washington, D.C., U.S.A. ....	FS
National Fire Protection Association, Boston, Mass., U.S.A. ....	NFPA
Underwriters' Laboratories, Inc., Chicago, Ill., U.S.A. ....	ULI
<hr/>	
British Standards Institution, London, W.1., England .....	BS

## SECTION 5.1 MATERIAL STANDARDS AND METHODS OF TESTING

### SUBSECTION 5.1.1. MATERIAL STANDARDS

5.1.1.1. Unless otherwise specified or *approved*,\* materials used in fulfilment of the requirements of this Bylaw shall conform to the appropriate standards listed in this Part.

5.1.1.2. Lumber shall conform to the grades for specific end uses listed in Table 9.3.3.A. in Part 9 of this Bylaw.

### SUBSECTION 5.1.2. METHODS OF TESTING

5.1.2.1. All required tests of materials shall be conducted according to the appropriate methods found in the standards listed in this Part, or in the absence of these, as specified by the *authority having jurisdiction* or other authority acceptable to him. All tests shall be conducted and reports thereon prepared at the expense of the *owner* or his agent. Laboratory tests shall be conducted by a laboratory acceptable to the *authority having jurisdiction*.

## SECTION 5.2 ALTERNATIVE MATERIALS

5.2.1. The provisions of this Bylaw are not intended to prevent the use of any material not specifically prescribed herein. Any such material may be *approved* provided it is shown to be satisfactory for the purpose intended and at least the equivalent of that required in this Bylaw in quality, strength, effectiveness, fire resistance, durability and safety.

5.2.2. Approval in writing shall be obtained by the *owner* or his agent before any alternative material is used. The *authority having jurisdiction* shall base such approval on the principle set forth in subsection 5.2.1. and shall require that tests be made or sufficient evidence or proof be submitted, at the expense of the *owner* or his agent, to substantiate any claim for the proposed material.

## SECTION 5.3 USED MATERIALS

5.3.1. Unless otherwise specified, used materials may be reused where these meet the requirements of this Bylaw for new materials, and are otherwise satisfactory for the intended use.

## SECTION 5.4 STORAGE OF MATERIALS

5.4.1. All building materials shall be stored on the building site in such a way as to prevent deterioration or the loss or impairment of their structural and other essential properties.

\*Words which are in italics in this Part are defined in Part 2.



**Standards Relevant to Plumbing  
issued by the  
Canadian Standards Association  
(178 Rexdale Blvd., Rexdale 603, Ontario)**

<b>A60. 1-1969</b>	<b>Vitrified Clay Pipe</b>
<b>A60. 3-1969</b>	<b>Vitrified Clay Pipe Joints</b>
<b>B45. 1-1963</b>	<b>Vitreous China Plumbing Fixtures</b>
<b>B62-1965</b>	<b>Welded Genuine Wrought-Iron Pipe</b>
<b>B63-1966</b>	<b>Welded and Seamless Steel Pipe</b>
<b>B67-1941</b>	<b>Lead Service Pipe, Waste Pipe, Traps, Bends and Accessories (Reaffirmed 1948 and 1964)</b>
<b>B70-1963</b>	<b>Cast Iron Soil Pipe and Fittings</b>
<b>B125-1967</b>	<b>Plumbing Fittings</b>
<b>B131. 5-1963</b>	<b>Cast Iron Pipe Centrifugally Cast in Metal Molds, for Water or Other Liquids</b>
<b>B131. 7-1963</b>	<b>Cast Iron Pipe Centrifugally Cast in Sand-Lined Molds, for Water or Other Liquids</b>
<b>B131. 11-1958</b>	<b>Universal Cast Iron Pipe and Fittings Cast in Sand-Lined Molds, for Water and Other Liquids</b>
<b>B137-1963</b>	<b>Polyethylene Pipe for Cold Water Services</b>
<b>B181. 1-1967</b>	<b>Acrylonitrile - Butadiene - Styrene Drain, Waste and Vent (ABS-DWV) Pipe and Pipe Fittings</b>
<b>B181. 2-1967</b>	<b>Poly (Vinyl Chloride) Drain, Waste and Vent Pipe and Pipe Fittings</b>
<b>B182. 1-1967</b>	<b>Plastic Drain and Sewer Pipe and Pipe Fittings for Use Underground</b>
<b>HC. 7. 5-1968</b>	<b>Seamless Copper and Red Brass Pipe</b>
<b>HC. 7. 6-1968</b>	<b>Seamless Copper Water Tube, Drainage Tube (DWV) and Hydronic Heating Tube (Type H)</b>

**Standards Relevant to Plumbing  
issued by the  
Canadian Government Specifications Board  
(c/o Department of Supply and Services, Ottawa 4, Ontario)**

<b>34-GP-1b May 1969</b>	<b>Pipe: Asbestos-Cement, Pressure</b>
<b>34-GP-9c May 1969</b>	<b>Pipe: Asbestos-Cement, Sewer</b>
<b>34-GP-22 11 Nov. 1966</b>	<b>Pipe: Asbestos-Cement, Drain (Amended: 30 May 69)</b>
<b>56-GP-1a 23 Nov. 1962</b>	<b>Pipe: Bituminized-Fibre, Drain and Sewer</b>
<b>56-GP-2a 6 Oct. 1967</b>	<b>Sealing Compound: Sewer Pipe Joint, Hot Pour, Mineral Filled, Bituminous</b>
<b>56-GP-3a 6 Oct. 1967</b>	<b>Sealing Compound: Sewer Pipe Joint, Hot Pour, Mineral Filled, Plastic</b>
<b>77-GP-1 19 Jan. 1962</b>	<b>Compound: Pipe Jointing, Cementitious, Cold Applied</b>

**Standards Relevant to Plumbing**  
 issued by the  
**American Society for Testing and Materials**  
 (1916 Race St., Philadelphia, Pa., U.S.A., 19103)

- |                |   |
|----------------|---|
| <b>A444-67</b> | <b>Zinc-Coated (Galvanized) Iron or Steel Sheets for Culverts and Underdrains</b> |
| <b>C14-68</b>  | <b>Concrete Sewer, Storm Drain and Culvert Pipe</b>                               |

**Standards Relevant to Plumbing**  
 issued by the  
**American National Standards Institute**  
 (1430 Broadway, New York, N.Y., U.S.A. 10018)

- |                        |   |
|------------------------|---|
| <b>A40. 5-1943</b>     | <b>Threaded Cast-Iron Pipe for Drainage, Vent and Waste Services</b>  |
| <b>A40. 6-1943</b>     | <b>Backflow Preventers in Plumbing Systems</b>  |
| <b>B16. 3-1963</b>     | <b>Malleable-Iron Screwed Fittings, 150 and 300 lb</b>  |
| <b>B16. 4-1963</b>     | <b>Cast-Iron Screwed Fittings, 125 and 250 lb</b>   |
| <b>B16. 12-1965</b>    | <b>Cast-Iron Threaded Drainage Fittings</b>   |
| <b>B16. 15-1964</b>    | <b>Cast Bronze Screwed Fittings, 125 and 250 lb</b>   |
| <b>B16. 18-1963</b>    | <b>Cast Bronze Solder-Joint Pressure Fittings</b>   |
| <b>(1967 Addendum)</b> |   |
| <b>B16. 22-1963</b>    | <b>Wrought Copper and Bronze Solder-Joint Pressure Fittings</b>   |
| <b>B16. 23-1969</b>    | <b>Cast Bronze Solder Joint Drainage Fittings—DWV</b>   |
| <b>B16. 24-1962</b>    | <b>Bronze Flanges and Flanged Fittings, 150 and 300 lb</b>  |
| <b>B16. 26-1967</b>    | <b>Cast Bronze Fittings for Flared Copper Tubes</b>   |
| <b>Z21. 22-1964</b>    | <b>Relief Valves and Automatic Gas Shutoff Devices for Hot Water Supply Systems, Listing Requirements for</b> |

## APPENDIX D

### Excerpts from Part 9:

#### Housing and Small Buildings

##### National Building Code of Canada 1970

9.10.9.9. Pipes and ducts that penetrate through a required *fire separation* shall be tightly fitted or *fire stopped* to prevent the passage of smoke and flame if such pipes or ducts are not enclosed in a shaft. Unenclosed ducts that penetrate through a required *fire separation* shall be provided with fire dampers installed to conform to Part 6 of this Bylaw (see also Subsection 9.10.5.).

Fire stopping of pipes and ducts

9.10.9.10. Every pipe, duct, electrical outlet box or other similar service equipment that partly or wholly penetrates through a required *fire separation* shall be *noncombustible* except that such equipment may be *combustible* where the assembly has been tested incorporating such *combustible* equipment (see also Subsection 9.10.4.).

Pipes, ducts, outlet boxes, etc.

9.10.12.9. The room or bin into which a refuse chute discharges shall be of sufficient size to contain the refuse between normal intervals of emptying. Such rooms or bin shall be impervious to moisture and shall have wash water supply and floor drains. Chute discharge rooms shall contain no other service equipment unless permitted by the *authority having jurisdiction*.

Design of refuse room or bin

9.10.12.11. Every refuse chute shall be equipped at the top with spray equipment for washing the chute.

Washing equipment

9.10.16.7. Where *fire stops* are pierced by pipes, ducts or other elements, the effectiveness of the *fire stops* shall be maintained around such elements.

Pipes and ducts piercing fire stops

#### SUBSECTION 9.14.6 SURFACE DRAINAGE

9.14.6.1. Adequate surface water drainage shall be provided over the entire *building* site.

Surface drainage

9.14.6.2. The *building* site shall be graded to direct surface water away from the *building*. Where the grading will result in the collection of surface water on the site, catch basins to carry such surface water from the site shall be installed or other acceptable method of drainage used to dispose of surface water without soil erosion. Surface drainage shall be directed away from the location of a water supply well or septic tank disposal bed.

Site drainage

9.14.6.3. Driveways, walks, terraces, retaining walls or other construction shall not be constructed to interfere with the flow of surface drainage. Where runoff water from a driveway is likely to accumulate or enter a garage, a catch basin shall be installed to provide adequate drainage.

Interference with surface drainage

9.14.6.4. Where downspouts are provided and are not connected to a sewer, provisions shall be made to prevent soil erosion.

Downspouts

## SECTION 9.32 PLUMBING

### SUBSECTION 9.32.1. SCOPE

- Plumbing** 9.32.1.1. This Section applies to the facilities required in *plumbing systems within dwelling units*.
- 9.32.1.2. Facilities in *plumbing systems other than those required in dwelling units* shall conform to Part 3 of this Bylaw.

### SUBSECTION 9.32.2. GENERAL

- Provincial plumbing regulations** 9.32.2.1. Every *plumbing system* shall conform to appropriate provincial regulations. In the absence of such regulations, the requirements of this Section shall apply.
- 9.32.2.2. The construction, extension, *alteration*, renewal or repair of *plumbing systems* shall conform to Part 7 of this Bylaw.

### SUBSECTION 9.32.3. WATER SUPPLY AND DISTRIBUTION

- Potable water** 9.32.3.1. Every *dwelling unit* shall be supplied with *potable water* from an *approved public or community system* when these systems are available.
- Cold water storage** 9.32.3.2. Where public or community systems are not available, every *dwelling unit* shall be supplied with an adequate supply of *potable water* from an *approved private source*. Where individual wells deliver less than 4 gal. per minute per *dwelling unit* over a 1-hr period, not less than 200 gal. cold water storage shall be provided per *dwelling unit*.
- Piping to facilities** 9.32.3.3. Piping for hot and cold water shall be connected to every kitchen sink, washbasin, bathtub, shower, slop sink and laundry area. Piping for cold water shall be run to every water closet and hose bib.

### SUBSECTION 9.32.4. REQUIRED FACILITIES

- Required facilities** 9.32.4.1. A kitchen sink, washbasin, bathtub and water closet shall be provided for every *dwelling unit* where a piped water supply is available. Where there is no piped water supply other *approved means of waste disposal* shall be provided for every *dwelling unit*.
- Laundry space** 9.32.4.2. Laundry facilities or a space for laundry facilities shall be provided in every *dwelling unit* or grouped elsewhere in the *building* in a location conveniently accessible to occupants of every *dwelling unit*.
- Hot water supply** 9.32.4.3. A hot water supply shall be provided in every *dwelling unit*.
- Floor drain** 9.32.4.4. Where gravity drainage to a sewer, drainage ditch or dry well is possible, a floor drain shall be installed in a basement or cellar forming part of a *dwelling unit*.

9.32.4.5. A floor drain shall be provided in a public laundry room, and in a garbage room, incinerator room, boiler or heating room serving more than one *dwelling unit*.

#### SUBSECTION 9.32.5. SEWAGE DISPOSAL

9.32.5.1. Except as provided in Article 9.32.4.1., wastes from every plumbing *fixture* shall be piped to the *building sewer*. Every laundry room or space shall have a waste connection for disposal of laundry water.

Sewage disposal

9.32.5.2. *Building sewers* shall discharge into a public sewage system where such system is available.

Building sewers discharge

9.32.5.3. Where a public sewage system is not available, the *building sewer* may discharge into a *private sewage disposal system* such as a septic tank and disposal field provided the design and installation is *approved*.

Private sewage disposal system

#### SUBSECTION 9.32.6. SERVICE WATER HEATING FACILITIES

9.32.6.1. Equipment shall be installed to provide to every *dwelling unit* an adequate supply of service hot water with a temperature range from 140° to 165°F.

Service water heating facilities

9.32.6.2. Service hot water may be distributed from a centrally located heater to supply the entire *building* or may be supplied by an individual *service water heater* for each *dwelling unit*.

Distribution of service hot water

9.32.6.3. Every *service water heater* and its installation shall conform to Part 6 of this Bylaw.

Installation

9.32.6.4. Where storage tanks for *service water heaters* are of steel, they shall be coated with zinc, vitreous enamel (glass lined), hydraulic cement or other *approved* corrosion-resistant material.

Storage tanks

9.32.6.5. Fuel-burning *service water heaters* shall be connected to a *chimney flue* conforming to Section 9.21.

Fuel-burning service water heaters

9.32.6.6. Heating coils of *service water heaters* shall not be installed in a *flue* or in a combustion chamber of a *building heating boiler* or *furnace* unless *approved* for such installations.

Heating coils

## APPENDIX E

### Excerpts from Supplement No. 1:

## CLIMATIC INFORMATION FOR BUILDING DESIGN IN CANADA

National Building Code of Canada 1970

### Rainfall Intensities

Province and Location	15 Min. Rain in.	Province and Location	15 Min. Rain in.	Province and Location	15 Min. Rain in.
<b>British Columbia</b>					
Abbotsford .....	0.4	Penticton .....	0.6	Coronation .....	0.6
Agassiz .....	0.4	Port Alberni .....	0.4	Cowley .....	0.5
Alberni .....	0.4	Port Hardy .....	0.5	Drumheller .....	0.7
Ashcroft .....	0.5	Port McNeill .....	0.5	Edmonton .....	0.9
Beaton River .....	0.5	Powell River .....	0.3	Edson .....	0.6
Campbell River .....	0.3	Prince George .....	0.4	Embarras Portage .....	0.4
Carmi .....	0.6	Prince Rupert .....	0.5	Fairview .....	0.6
Chilliwack .....	0.4	Princeton .....	0.5	Fort Saskatchewan .....	0.8
Cloverdale .....	0.3	Quesnel .....	0.4	Fort Vermilion .....	0.3
Comox .....	0.3	Revelstoke .....	0.6	Grande Prairie .....	0.6
Courtenay .....	0.3	Richmond .....	0.3	Habay .....	0.4
Cranbrook .....	0.5	Salmon Arm .....	0.6	Hardisty .....	0.5
Crescent Valley .....	0.6	Sandspit .....	0.5	High River .....	0.8
Crofton .....	0.3	Sidney .....	0.2	Jasper .....	0.4
Dawson Creek .....	0.6	Smithers .....	0.4	Keg River .....	0.4
Dog Creek .....	0.4	Smith River .....	0.3	Lac la Biche .....	0.6
Duncan .....	0.3	Squamish .....	0.4	Lacombe .....	0.7
Elko .....	0.5	Stewart .....	0.4	Lethbridge .....	0.5
Fernie .....	0.5	Taylor .....	0.6	McMurray .....	0.6
Fort Nelson .....	0.5	Terrace .....	0.5	Manning .....	0.5
Fort St. John .....	0.6	Tofino .....	0.5	Medicine Hat .....	0.4
Glacier .....	0.6	Trail .....	0.6	Peace River .....	0.6
Golden .....	0.5	Ucluelet .....	0.5	Penhold .....	0.7
Haney .....	0.3	Vancouver .....	0.3	Pincher Creek .....	0.5
Hope .....	0.5	Vernon .....	0.6	Ranfurly .....	0.7
Kamloops .....	0.5	Victoria .....	0.2	Red Deer .....	0.7
Kelowna .....	0.6	Williams Lake .....	0.4	Rocky Mountain House .....	0.8
Kimberley .....	0.5	Youbou .....	0.4	Slave Lake .....	0.7
Kitimat Plant .....	0.5	<b>Alberta</b>			
Kitimat Townsite .....	0.5	Athabaska .....	0.7	Stettler .....	0.7
Langley .....	0.3	Banff .....	0.7	Suffield .....	0.5
Lytton .....	0.5	Beaverlodge .....	0.6	Taber .....	0.5
McLeod Lake .....	0.5	Brooks .....	0.6	Turner Valley .....	0.8
Masset .....	0.5	Calgary .....	0.9	Valleyview .....	0.7
Mission City .....	0.4	Campsie .....	0.8	Vegreville .....	0.7
Nanaimo .....	0.3	Camrose .....	0.7	Vermilion .....	0.6
Nelson .....	0.6	Cardston .....	0.5	Wagner .....	0.7
New Westminster .....	0.3	Clareholm .....	0.6	Wainwright .....	0.6
North Vancouver .....	0.4	Cold Lake .....	0.6	Wetaskiwin .....	0.8
Ocean Falls .....	0.5	Coleman .....	0.5	Whitecourt .....	0.7
Osoyoos .....	0.6			Wimborne .....	0.7

Province and Location	15 Min. Rain in.	Province and Location	15 Min. Rain in.	Province and Location	15 Min. Rain in.
<b>Saskatchewan</b>					
Assiniboia .....	0.6	St. Boniface .....	0.6	Chelmsford .....	1.0
Battrum .....	0.3	St. Vital .....	0.6	Chesley .....	1.1
Biggar .....	0.5	Sandilands .....	0.7	Clinton .....	1.1
Broadview .....	0.6	Selkirk .....	0.6	Coboconk .....	1.1
Dafoe .....	0.6	Split Lake .....	0.4	Cobourg .....	1.2
Dundurn .....	0.4	Steinbach .....	0.7	Cochrane .....	0.9
Estevan .....	0.8	Swan River .....	0.6	Colborne .....	1.2
Hudson Bay .....	0.7	The Pas .....	0.6	Collingwood .....	1.1
Humboldt .....	0.6	Thompson .....	0.4	Cooksville .....	1.0
Island Falls .....	0.4	Transcona .....	0.6	Cornwall .....	1.0
Kamsack .....	0.7	Virden .....	0.8	Corunna .....	0.9
Kindersley .....	0.4	Whiteshell .....	0.6	Deep River .....	0.9
Lloydminster .....	0.6	Winnipeg .....	0.6	Deseronto .....	1.1
Maple Creek .....	0.4	<b>Ontario</b>			
Meadow Lake .....	0.6	Ailsa Craig .....	1.2	Dorchester Sta. ..	1.3
Melfort .....	0.6	Ajax .....	1.1	Dorion .....	0.7
Melville .....	0.7	Alexandria .....	0.9	Dresden .....	1.1
Moose Jaw .....	0.5	Alliston .....	1.1	Dryden .....	0.9
Nipawin .....	0.6	Almonte .....	1.0	Dunbarton .....	1.1
North Battleford ..	0.6	Ansonville .....	0.9	Dunnville .....	1.0
Prince Albert .....	0.6	Armstrong .....	0.9	Durham .....	1.1
Qu'Appelle .....	0.6	Arnprior .....	0.9	Dutton .....	1.1
Regina .....	0.6	Atikokan .....	1.0	Earlton .....	1.0
Saskatoon .....	0.4	Aurora .....	1.1	Edison .....	0.9
Scott .....	0.6	Bancroft .....	1.1	Elmvale .....	1.1
Strasbourg .....	0.6	Barrie .....	1.1	Embro .....	1.3
Swift Current .....	0.3	Barriefield .....	0.9	Englehart .....	1.0
Uranium City .....	0.3	Beaverton .....	1.1	Espanola .....	1.0
Weyburn .....	0.7	Belleville .....	1.3	Exeter .....	1.2
Yorkton .....	0.7	Belmont .....	1.2	Fergus .....	1.2
<b>Manitoba</b>					
Beausejour .....	0.6	Bowmanville .....	1.1	Fonthill .....	1.0
Boissevain .....	0.9	Bracebridge .....	1.0	Forest .....	1.0
Brandon .....	0.8	Bradford .....	1.1	Fort Erie .....	1.0
Churchill .....	0.3	Brampton .....	1.1	Fort Frances .....	1.0
Dauphin .....	0.6	Brantford .....	1.1	Fort William .....	0.7
Flin Flon .....	0.5	Brighton .....	1.3	Galt .....	1.2
Gimli .....	0.5	Brockville .....	1.0	Gananoque .....	0.9
Island Lake .....	0.5	Brooklin .....	1.1	Georgetown .....	1.1
Lac du Bonnet .....	0.6	Burks Falls .....	1.1	Geraldton .....	0.8
Lynn Lake .....	0.3	Burlington .....	1.0	Glencoe .....	1.1
Morden .....	0.9	Caledonia .....	1.1	Goderich .....	1.1
Neepawa .....	0.7	Campbellford .....	1.3	Gore Bay .....	1.0
Pine Falls .....	0.5	Camp Borden .....	1.1	Graham .....	0.9
Portage la Prairie ..	0.7	Cannington .....	1.1	Gravenhurst .....	1.1
Rivers .....	0.8	Carleton Place .....	1.0	Grimsby .....	1.0
		Cavan .....	1.2	Guelpf .....	1.2
		Centralia .....	1.2	Guthrie .....	1.1
		Chapleau .....	0.9	Hagersville .....	1.1
		Chatham .....	1.1	Haileybury .....	1.0
				Haliburton .....	1.1

Province and Location	15 Min. Rain in.	Province and Location	15 Min. Rain in.	Province and Location	15 Min. Rain in.
Hamilton	1.0	Oakville	1.0	South Porcupine	0.9
Hanover	1.1	Orangeville	1.2	Stirling	1.3
Hastings	1.3	Orillia	1.1	Stratford	1.3
Hawkesbury	0.9	Oshawa	1.1	Strathroy	1.2
Hearst	0.8	Ottawa	0.9	Sturgeon Falls	1.1
Honey Harbour	1.0	Owen Sound	1.0	Sudbury	1.0
Hornepayne	0.8	Pagwa	0.8	Sundridge	1.1
Huntsville	1.0	Paris	1.2	Tavistock	1.3
Ingersoll	1.3	Parkhill	1.2	Thamesford	1.3
Jarvis	1.1	Parry Sound	1.0	Theford	1.1
Jellicoe	0.8	Pembroke	0.9	Tillsonburg	1.1
Kapusking	0.8	Penetanguishene	1.0	Timagami	1.1
Kemptville	1.1	Perth	1.1	Timmins	0.9
Kenora	0.9	Petawawa	0.9	Toronto	1.0
Killaloe	1.0	Peterborough	1.2	Trenton	1.3
Kincardine	1.0	Petrolia	1.0	Trout Creek	1.1
Kingston	0.9	Picton	1.1	Trout Lake	0.5
Kinmount	1.1	Plattsville	1.3	Uxbridge	1.2
Kirkland Lake	1.0	Point Alexander	0.9	Vanier	0.9
Kitchener	1.3	Porcupine	0.9	Vittoria	1.0
Lakefield	1.2	Port Arthur	0.7	Walkerton	1.1
Lansdowne House	0.7	Port Burwell	1.0	Wallaceburg	1.1
Leamington	1.1	Port Colborne	1.0	Waterloo	1.3
Lindsay	1.2	Port Credit	1.0	Wafford	1.1
Lions Head	1.0	Port Dover	1.0	Wawa	0.9
Listowel	1.3	Port Elgin	1.0	Welland	1.0
London	1.3	Port Hope	1.2	West Lorne	1.1
Lucan	1.3	Port Perry	1.2	Whitby	1.1
Maitland	1.0	Port Stanley	1.0	White River	0.8
Markdale	1.1	Prescott	1.0	Warton	1.0
Martin	0.9	Princeton	1.2	Windsor	1.1
Matheson	0.9	Raith	0.8	Wingham	1.1
Mattawa	1.0	Red Lake	0.7	Woodstock	1.3
Midland	1.0	Renfrew	0.9	Wyoming	1.0
Milton	1.1	Ridgeway	1.0		
Milverton	1.3	Rockland	0.9	Quebec	
Minden	1.1	St. Catharines	1.0	Acton Vale	0.8
Mitchell	1.3	St. Marys	1.3	Alma	0.7
Moosonee	0.7	St. Thomas	1.0	Amos	0.9
Morrisburg	1.0	Sarnia	0.9	Ancienne Lorette	0.8
Mount Forest	1.2	Sault Ste. Marie	1.0	Arvida	0.7
Muskoka Arpt.	1.1	Schreiber	0.8	Asbestos	0.9
Nakina	0.8	Seaforth	1.2	Aylmer	0.9
Napanee	1.1	Simcoe	1.1	Bagotville	0.7
Newcastle	1.1	Sioux Lookout	0.9	Baie Comeau	0.6
New Liskeard	1.0	Smiths Falls	1.1	Beaconsfield	0.8
Newmarket	1.1	Smithville	1.0	Bedford	0.9
Niagara Falls	1.0	Smooth Rock Falls	0.8	Beloeil	0.8
North Bay	1.1	Southampton	1.0	Brossard	0.8
Norwood	1.2			Buckingham	0.9



Province and Location	15 Min. Rain in.	Province and Location	15 Min. Rain in.	Province and Location	15 Min. Rain in.
Cacouna	0.7	Matane	0.6	Shawville	0.9
Campbells Bay	0.9	Megantic	0.9	Sherbrooke	0.9
Camp Valcartier	0.8	Mont Joli	0.7	Sillery	0.8
Chicoutimi	0.7	Mont Laurier	0.9	Sorel	0.8
Coaticook	0.9	Montmagny	0.8	Sutton	0.9
Contrecoeur	0.8	Montreal	0.8	Tadoussac	0.7
Cowansville	0.9	Montreal Nord	0.8	Temiscaming	1.1
Dolbeau	0.7	Mount Royal	0.8	Theftford Mines	0.8
Dorval	0.8	Nitchequon	0.3	Three Rivers	0.8
Drummondville	0.8	Noranda	0.9	Thurso	0.9
Farnham	0.9	Outremont	0.8	Val d'Or	0.9
Fort Chimo	0.2	Pierrefonds	0.8	Valleyfield	0.9
Fort Coulonge	0.9	Pincourt	0.9	Varennes	0.8
Gagnon	0.4	Plessisville	0.8	Verchères	0.8
Gaspé	0.4	Pointe Claire	0.8	Verdun	0.8
Gatineau	0.9	Port Alfred	0.7	Victoriaville	0.8
Gatineau-Pointe	0.9	Port Cartier	0.5	Ville d'Anjou	0.8
Gentilly	0.8	Port Harrison	0.2	Ville Marie	1.0
Gracefield	0.9	Preville	0.8	Waterloo	0.9
Granby	0.9	Quebec	0.8	Westmount	0.8
Great Whale River	0.3	Richmond	0.9	Windsor Mills	0.9
Harrington		Rimouski	0.7		
Harbour	0.4	Rivière du Loup	0.7	New Brunswick	
Havre St. Pierre	0.4	Roberval	0.7	Alma	0.7
Hemmingford	0.9	Rock Island	0.9	Bathurst	0.7
Hull	0.9	Rosemere	0.8	Campbellton	0.7
Iberville	0.9	Rouyn	0.9	Chatham	0.7
Joliette	0.8	St. Agathe des Monts	0.9	Edmundston	0.8
Jonquiere	0.7	St. Anne de Bellevue	0.9	Fredericton	0.9
Kenogami	0.7	St. Canut	0.9	Gagetown	0.8
Knob Lake	0.3	St. Félicien	0.7	Grand Falls	0.8
Knowlton	0.9	St. Foy	0.8	Moncton	0.7
Kovik Bay	0.2	St. Hubert	0.8	Oromocto	0.9
Lachine	0.8	St. Hubert de Temiscouata	0.7	Sackville	0.7
Lachute	0.9	St. Hyacinthe	0.8	Saint John	0.7
Lafleche	0.8	St. Jérôme	0.9	St. Stephen	0.8
La Malbaie	0.8	St. Johns	0.9	Shippigan	0.5
La Salle	0.8	St. Jovite	0.9	Woodstock	0.9
La Tuque	0.7	St. Lambert	0.8		
Laval	0.8	St. Laurent	0.8	Nova Scotia	
Lennoxville	0.9	St. Nicolas	0.8	Amherst	0.6
Léry	0.9	Schefferville	0.3	Antigonish	0.4
Les Saules	0.8	Senneterre	0.9	Bridgewater	0.6
Levis	0.8	Seven Islands	0.5	Canso	0.5
Loretteville	0.8	Shawinigan	0.8	Dartmouth	0.6
Louiseville	0.8			Debert	0.5
Magog	0.9			Digby	0.5
Malartic	0.9			Greenwood	0.5
Maniwaki	0.9			Halifax	0.6
Masson	0.9			Kentville	0.5

Province and Location	15 Min. Rain in.	Province and Location	15 Min. Rain in.	Province and Location	15 Min. in. Rain
Liverpool .....	0.6	Corner Brook .....	0.3	Cambridge Bay .....	0.1
Lockeport .....	0.6	Gander .....	0.5	Chesterfield .....	0.2
Louisburg .....	0.5	Goose Bay .....	0.3	Clyde .....	0.2
Lunenburg .....	0.6	Grand Bank .....	0.5	Coppermine .....	0.2
New Glasgow .....	0.4	Grand Falls .....	0.4	Coral Harbour .....	0.2
North Sydney .....	0.4	Labrador City .....	0.4	Eskimo Point .....	0.2
Pictou .....	0.4	Port aux Basques .....	0.4	Eureka .....	0.1
Port Hawkesbury .....	0.4	St. Anthony .....	0.4	Fort Good Hope .....	0.2
Springhill .....	0.6	St. John's .....	0.6	Fort Providence .....	0.3
Stewiacke .....	0.5	Stephenville .....	0.3	Fort Resolution .....	0.3
Sydney .....	0.4	Twin Falls .....	0.3	Fort Simpson .....	0.3
Tatamagouche .....	0.4	Wabana .....	0.6	Fort Smith .....	0.3
Truro .....	0.5	Wabush Lake .....	0.4	Frobisher .....	0.2
Wolfville .....	0.5	Yukon		Hay River .....	0.3
Yarmouth .....	0.5	Aishihik .....	0.3	Holman Island .....	0.1
Prince Edward Island		Dawson .....	0.3	Inuvik .....	0.2
Charlottetown .....	0.3	Destruction Bay .....	0.3	Isachsen .....	0.1
Souris .....	0.3	Snag .....	0.3	Mould Bay .....	0.1
Summerside .....	0.4	Teslin .....	0.2	Norman Wells .....	0.2
Tignish .....	0.4	Watson Lake .....	0.3	Nottingham Island .....	0.2
Newfoundland		Whitehorse .....	0.2	Port Radium .....	0.2
Argentia .....	0.6	Northwest Territories		Rae .....	0.2
Bonavista .....	0.6	Aklavik .....	0.2	Rankin Inlet .....	0.2
Buchans .....	0.3	Alert .....	0.1	Resolute .....	0.1
Cape Harrison .....	0.3	Arctic Bay .....	0.1	Resolution Island .....	0.2
Cape Race .....	0.6	Baker Lake .....	0.1	Yellowknife .....	0.2

## INDEX

### A

- Abbreviations, 16
- Acrylonitrile-butadiene-styrene (ABS) pipe, 27, 36, 39
- Administration
  - Plumbing, 17–18
  - Part 1 NBC, 103
- Air break, 47–48
- Air chambers (shock stops), 96
- Air gap, 96–97
- Air test, 42–43
- Application of regulations, 17, 104
- Approval, certificate of, 18
- Asbestos cement pipe and fittings, 26
- Aspirators, 96

### B

- Backfill for piping, 40
- Backflow
  - preventer, 3
  - protection from, 54, 96, 99
- Back-siphonage
  - device, 2, 96
  - preventer, 2, 33, 96–99
- Backwater valve, 44, 54
- Ball test, 42–43
- Bathtub, 19
- Bituminized fibre pipe and fittings, 27
- Branch, hydraulic load on, 61
  - serving water closets, 66
- Branch vent, 3–4, 88
- Brass pipe, 29
- Brass pipe flanges and fittings, 29
- Brass plugs for cleanout ferrules, 32
- Bronze pipe flanges and fittings, 29
- Building classification, 111–114
- Building drain
  - cleanout, 56
  - combined, 52
  - hydraulic load on, 63–64
  - protection from backflow, 54–56
  - protection from damage, 40–41
  - size of, 66, 67–74
  - trapping of, 57
- Building sewer
  - combined, 52
  - hydraulic load on, 63–64
  - size of, 66
  - slope of, 59

- Building trap, 23
  - cleanout for, 58
  - location of, 54
  - venting of, 84
- Burned lead joint, 35, 36

### C

- Cast brass or bronze fittings, 29–30
- Cast iron pipe and fittings, 28
- Caulked lead drainage joint, 34
- Caulking compounds,
  - cold and hot poured, 32
- Cement joint, 35
- Cement jointing mortar, 32
- Certificate of approval, 18
- Check valve, 94
- Circuit vent, 4, 79–80, 90
- Classification of buildings, 111–114
- Cleaning of water system, 96
- Cleanout, 56–59
  - ferrule, 32
  - for traps, 23
  - types of, 58
- Climatic data, 109–110, 127–131
- Cock, stop-and-waste, 94–95
- Cold caulked joint, 36
- Cold water storage, dwelling units, 124
- Combined building drain, 52
- Combined building sewer, 52
- Compounds, caulking and sealing, 32
- Concrete pipe, 27
- Connections
  - fixture, 36–37, 44–47
  - indirect, 45–47
  - to drainage systems, 43–44
  - to horizontal offset, 44
  - to lead bend, 45
- Continuous vent, 87–88
- Cooling of hot waste, 48
- Copper pipe, 29
- Copper tube, 29
- Corrugated steel pipe, 28–29
- Cross fitting, 24

### D

- Definitions, 1–15, 17
- Developed length of vents, 87–90
- Diameter (see size)

Dissimilar materials or sizes,  
 joints for pipes, 36  
 Double Y fitting, 25–26  
 Double Y and 1/8th bend fitting, 25–26  
 Drain (see building drain, building subdrain,  
 fixture drain)  
 Downspouts (see leaders)  
 Drainage joint, caulked lead, 34  
 Drainage piping  
 arrangement of, 54–59  
 hydraulic loads on, 60–65  
 minimum slope, 59  
 sizing of, 66–74  
 Drainage  
 subsoil, 44, 56  
 surface water at site, 123  
 Drainage system, 14–15, 43–74  
 connection of, 43–44  
 sanitary, 43, 124–125  
 storm, 43  
 testing of, 42–43  
 Drain valve, 94  
 Drilled and tapped joint, 36  
 Drinking fountain, 19, 21, 45  
 Drip pipe, cleanout for, 57  
 Drip valve, 94  
 Dual venting, 77

## E

Eavestroughs (see gutters, roof)  
 Effective opening, 6  
 Ejector, 96  
 Electrical insulation at piping supports, 37  
 Expansion joints, plastic pipe, 37

## F

Facilities required, plumbing, 115–118  
 Faucets, 33, 94  
 Ferrous pipe and fittings, 28–29  
 Ferrule, cleanout, 32–33  
 Fire stopping at pipes, 115, 123  
 Fittings, 24–31  
 brass or bronze pipe, 29  
 downstream of traps, 24  
 ferrous, 28–29  
 flared joint, 30  
 marking, 19  
 non-ferrous, 29–30  
 non-metallic, 26–27  
 restrictions on use, 24–26, 76

screwed, 28  
 solder-joint, 29–30  
 Fixtures  
 connections to drainage system, 44  
 connections to vent pipe, 45  
 construction of, 19–22  
 for dwelling units, 124  
 hydraulic load from, 50–51, 60–61  
 indirectly connected, 74  
 installation of, 48  
 location of, 47–48  
 materials for, 19–20  
 special purpose, 19

Fixture drains  
 bends in, 76  
 cleanouts for, 57  
 connections to continuous vent, 76  
 connections to wet vents, 77  
 fall on, 75  
 for floor outlet fixtures, 36  
 for indirectly connected fixtures, 74  
 length of, 75  
 minimum slope, 59  
 protection from backflow, 54–55  
 size of, 66  
 venting of, 74–76

Fixture outlet pipe, 6, 66

Fixture unit  
 conversion to square feet, 61  
 explanation of, 67–69

Flared joint, 34

Flared joint fittings, 30

Flashing, vent pipe, 32–33

Floor drain  
 connections to drainage system, 44  
 dwelling units, 124–125  
 for refuse room or bin, 123  
 protection from backflow, 54  
 trap for basement, 75

Floor flanges, 32, 36

Floor outlet fixtures, drain connections, 36

Flushing device, 21, 48

Forged solder-joint fittings, 30

Freezing, protection from, 95

Fresh air inlet, 91

## G

Gallons per minute, conversion to fixture  
 units, 60, 68–69

Garbage grinder, 48

Grease interceptor (see interceptors)

Gutters, roof, 65

**H**

- Hangers, pipe, 37, 39
- Headers, 88–89
- Horizontal offset, connections to, 44, 46
- Horizontal piping, support of, 37, 39
- Hot poured joint, 34
- Hot water supply in dwelling units, 124
- Hub and spigot pipe, 54
- Hydraulic loads, 60–65
  - determination of, 67–74

**I**

- Increaser fitting, 36
- Indirect connections, 45–47
- Individual vent, 87
- Inlet, fresh air, 91
- Inspection, 18
- Installation of fixtures, 48
- Insulation, electrical at piping supports, 37
- Intensity, rainfall, table of, 127–131
- Interceptors
  - design of, 24
  - replacing trap, 49–50
  - restricted use, 48
  - venting of, 84
  - where required, 48–49

**J**

- Jointing materials, 32
- Joints, pipe, 34–37

**L**

- Laundry facilities in dwelling units, 124
- Laundry tray, 19–20
- Lead
  - caulking, 32
  - flashing, 32–33
  - pipe, 30
- Leaders (downspouts)
  - connections to roof hopper, 36
  - exposed to damage, 42
  - hydraulic load on, 65
  - restricted use of, 54
  - sheet metal, 29
  - soil erosion by, 123
  - trap for, 23, 52–53
- Load
  - hydraulic, 60–74
  - occupant, 115–116
- Loop vent, 4, 9, 79–80, 90

**M**

- Main vent, 8, 9, 66
- Malleable iron fittings, 28
- Manholes, as cleanouts, 59
- Markings on pipes and fittings, 19, 101
- Materials
  - defects in, 19
  - for fittings, 24–30
  - for fixtures, 19–22
  - for traps and interceptors, 22–24
  - jointing, 32
  - markings, 19
  - miscellaneous, 32–33
  - standards for (Part 5), 119–122
  - used, 19
  - Mechanical joint, 35
- Mobile home service building, 118
- Mortar, cement jointing, 32

**N**

- Non-ferrous pipe and fittings, 29–30
- Non-metallic pipe and fittings, 26–27
- Non-potable water system
  - connections to potable water, 96, 101
  - identification, 101
  - location of pipes and outlets, 101
- Numbering system, ix

**O**

- Occupancy, classification of building by
  - major, 111–114
- Occupant load, 115–116
- Offsets in piping, 10
- Oil interceptor (see interceptors)
- Open-hearth iron pipe, 29
- Outlet, non-potable water system, 101
- Overflows
  - fixture, 20
  - rainwater tank, 44

**P**

- Paved surface, hydraulic load from, 61
- Permit, 17–18
- Pipe
  - acrylonitrile-butadiene-styrene (ABS), 27, 36, 39
  - applications, summary, 31
  - asbestos-cement drainage, 26, 39, 40
  - asbestos-cement water, 26, 39
  - bituminized fibre, 27, 40
  - brass, 29

- cast-iron soil, 28, 39
  - cast-iron water, 28, 39
  - concrete, 27
  - copper, 29
  - corrugated steel, 28–29
  - diameter of, 66–74
  - flanges and fittings, brass or bronze, 29
  - hub and spigot, 37, 54
  - joints and connections, 34–37
  - lead waste, 30
  - lead water, 30
  - marking, 19
  - noncombustible, 115, 123
  - open ends prohibited, 54
  - open-hearth iron, 29
  - plastic sewer, 27
  - polyethylene water, 27, 94
  - polyvinyl chloride (PVC), 27, 36, 39
  - protection, 40–42
  - sheet metal, 29
  - sizing, 66–74
  - subsoil drainage, 52–53, 56
  - supports, 37–40
  - threaded cast iron, 28
  - underground (see underground pipe)
  - vitrified clay, 27, 40
  - water supply, 94–100
  - welded and seamless steel, 28–29
  - wrought iron, 28
  - Piping
    - drainage of, 94
    - service, 37–38, 124
    - support of, 37–40
  - Plastic pipe and fittings, 27, 36–37, 39
  - Plugs, cleanout ferrule, 32
  - Plumbing contractor, 17–18
  - Plumbing facilities required, 115–118
  - Plumbing systems, 11
    - certificate of approval, 18
    - in dwelling units, 124–125
    - inspection and testing, 18
    - plans and drawings, 18
    - responsibility of contractor, 18
  - Polyethylene pipe, 27, 94
  - Polyvinyl chloride (PVC) pipe, 27, 36, 39
  - Potable water system
    - arrangement of piping, 94–96
    - connections to non-potable water system, 96, 101
    - design of, 99–100
    - for dwelling units, 124
    - protection from contamination, 96–99
    - tanks, 99
    - testing of, 43
    - wells, 99
  - Pressure reducing valves, 100
  - Pressure relief valves
    - specifications, 33
    - where required, 95
  - Private sewage disposal system, 66
  - Private water supply, 96
  - Proportional weir roof drains, 61
  - Protection of piping, 40–42
  - PVC (see Polyvinyl chloride pipe)
- Q**
- Quarter bend fitting, 26
- R**
- Rainfall intensities, table of, 127–131
  - Reducer fitting, 36
  - Refuse chute, spray equipment for, 123
  - Refuse room, water supply and drain, 123
  - Relief valves
    - discharge pipe, 95
    - outlets, 44
    - specifications, 33
    - where required, 95
  - Relief vent
    - connections, 80–81
    - minimum size, 90
  - Relief venting, 81
  - Rooms for sanitary facilities, 47, 118
  - Roof gutters, 65
  - Roof hopper
    - leader connections, 36
    - proportional weir type, 61
  - Roof, hydraulic load from, 61
- S**
- Saddle hub, 32
  - Sanitary building drain or sewer (see building drain or building sewer)
  - Sanitary drainage system, 43–74
  - Sanitary T-Y fitting, 24–25
  - Scope, 17
  - Screwed cast-iron drainage fittings, 28
  - Screwed joint, 34
  - Service piping, 37–38
  - Service water heaters, 95, 125
  - Sewage disposal system, private, 66, 125
  - Sewage, treatment and disposal, 48–49, 125
  - Sewer (see building sewer)
  - Sheet metal leader, 29
  - Shock stops, 96
  - Shower receptor, 19, 21
  - Shut-off valves, 94–95

Sink, 19  
 Sisson fitting, 26  
 Size of  
   cleanouts, 59  
   drainage pipes, 66  
   traps, 50–51  
   vent pipes, 86–94  
   waste openings, 20  
   water supply pipes, 99–100  
 Slip joint, 36  
 Slope of drainage pipes, 59  
 Smoke test, 42–43  
 Soil-or-waste pipe, size of, 66  
 Soil-or-waste stack  
   hydraulic load on, 61–62  
   size of, 66  
   vent stacks for, 81  
 Soil pipe, cast-iron, 28  
 Solder, 32  
 Soldered joint, 34  
 Solder-joint fittings, 29–30  
 Spray equipment for refuse chute, 123  
 Stack, hydraulic load on, 61–62  
 Stack vent  
   extension of stack, 81  
   size of, 83, 90–91  
 Stack venting, 77–79  
 Steel pipe, 28–29  
 Stop and waste cock, 94–95  
 Storage type service water heaters, 95, 125  
 Storm drainage system  
   connection of, 43  
   hydraulic load, 64  
   sizing of, 69–71  
   sumps, 54–55  
   traps required, 52–53  
 Strainer, 20  
 Stub, lead water closet, 37  
 Subsoil drainage  
   backflow protection, 55–56  
   connection of, 52–53  
   disposal of, 44  
 Sumps, 54  
   venting of, 84, 90  
 Support piping, 37–40  
 Symbols, ix

**T**

T fitting, 24  
 Tanks, potable water, 99, 124  
 Temperature limit control, 95  
 Temperature relief valve  
   specifications, 33  
   where required, 95

Terminals, vent pipe, 85–86  
 Testing  
   drainage and venting systems, 42–43  
   potable water system, 43  
 Threaded cast-iron pipe, 28  
 Trap seals  
   maintaining, 52  
   size of, 22–23  
 Traps  
   connections of, 22–23, 75  
   design of, 22–23  
   for fixtures, 49–51  
   for storm drainage system, 52–53  
   for subsoil drains, 52–53  
   interceptors used as, 49–50  
   location of, 50, 54  
   prohibited, 23  
   size of, 50–51  
   venting of, 74–81  
 Treatment of harmful sewage  
   and wastes, 48–49, 125  
 Trough urinal, 21  
 Tube copper, 29

## U

Underground pipe  
   protection of, 40  
   support of, 39–40  
 Unions and slip joints, 36  
 Urinals  
   construction, 19, 21  
   installation, 48  
   location, 47  
   trough, 21  
 Used material, 19

## V

Vacuum breaker (see back-siphonage preventer)  
 Valves  
   accessibility, 94  
   backwater, 44  
   check, 94  
   pressure reducing, 100  
   pressure relief, 33, 95  
   shut-off, 94–95  
   temperature relief, 95  
 Venting  
   circuit, 79–80  
   dual, 77  
   for traps, 74–81  
   loop, 79–80  
   of floor drains in basements, 75

- of oil interceptor, 84
- of sewage sump, 84
- stack, 77-79
- testing of system, 42-43
- wet, 77-78
- Vent pipes
  - arrangement of, 84-86
  - fixture connections to, 45
  - for future fixtures, 87
  - location, 84-86
  - not required, 74-75
  - sizing of, 86-94
  - support above roof, 39
- Vent stacks
  - terminals, 85-86
  - sizing of, 90-91
  - where required, 81
- Vertical piping, support of, 37
- Vitreous china fixtures, 19
- Vitrified clay pipe, 27, 40

**W**

- Wash basins, 19
  - number required, 117
- Waste opening, diameter, 20
- Waste pipe, lead, 30
- Waste, treatment of, 48-49
- Water closet

- bowl, 19
  - construction, 21
  - installation, 48
  - number required, 115, 117-118
  - rooms, 118
- Water heater, storage type, 95, 125
- Water pipe
  - lead, 30
  - size and capacity, 99-100
- Water supply
  - for dwelling units, 124
  - for fixtures, 100
  - for refuse room, 123
- Water system (see potable water system, non-potable water system)
- Water test, 42, 43
- Welded and seamless steel pipe, 28
- Welded joint, 36
- Wells, 99
- Wet venting, 77-78
- Wiped joint, 34
- Wrought-iron pipe, 28

**Y**

- Y and 1/8th bend fitting, 26
- Yoke vent
  - minimum diameter, 91
  - where required, 81-83



**Reference has been made throughout this document to the National Building Code of Canada 1970. Copies of the National Building Code and its supplements can be obtained by writing to:**

**THE SECRETARY,  
ASSOCIATE COMMITTEE ON THE NATIONAL BUILDING CODE,  
NATIONAL RESEARCH COUNCIL OF CANADA  
OTTAWA, ONTARIO. K1A 0R6**