

22 May 1985

**CANADIAN
PLUMBING CODE
1985**

ARCHIVES

Issued by the

**Associate Committee on the National Building Code
National Research Council of Canada
Ottawa**

Price \$8.00

NRCC No. 23176

ASSOCIATE COMMITTEE ON THE NATIONAL BUILDING CODE

| | |
|--|---------------------------------------|
| J. Longworth (<i>Chairman</i>) | E.I. Mackie |
| A.G. Wilson (<i>Chairman</i>) ⁽¹⁾ | W.M. McCance ⁽¹⁾ |
| R.A. Hewett (<i>Executive Officer</i>) | L.L. Merrifield |
| H.D. Adam (<i>ex officio</i>) | D.O. Monsen |
| R.W. Anderson | J.R. Myles |
| B.A. Bonser ⁽¹⁾ | F.-X. Perreault |
| R.L. Booth | W.A. Proudfoot ⁽⁴⁾ |
| K.W.J. Butler | P.J.H. Sheasby (<i>ex officio</i>) |
| D.E. Cornish | G.W. Shorter |
| S. Cumming | M. Stein |
| R.F. DeGrace | R.T. Tamblyn ⁽¹⁾ |
| M.G. Dixon | D.L. Tarlton |
| B. Garceau | A.D. Thompson |
| L. Goulard | A.M. Thorimbert (<i>ex officio</i>) |
| J.S. Hicks | J.E. Turnbull |
| G.A. Hope ⁽¹⁾ | |
| R.M. Horrocks | R.H. Dunn ⁽³⁾ |
| J.C. Hurlburt | A.T. Hansen ⁽³⁾ |
| A. Koehli | R.A. Kearney ⁽²⁾ |
| W.D. MacKay | J.K. Richardson ⁽²⁾ |

STANDING COMMITTEE ON PLUMBING SERVICES

| | |
|-----------------------------------|---------------------------|
| A.D. Thompson (<i>Chairman</i>) | G. Okabe |
| E. Bélanger | R. Scott |
| D.P. Carritt | P.G. Spenst |
| R.J. Clegg | A.C. Spurrell |
| G.L. Cluett | L.F. Stanbrook |
| J. Cooney | J.E. Stott |
| H.S. Darragh ⁽¹⁾ | A.J. Thomson |
| H.C. Gillis | D. Walker |
| R.J. Hunt ⁽¹⁾ | J.D. Whiteley |
| A.A. Knapp | |
| D.S. McDonald | D.A. Lutes ⁽²⁾ |

JOINT NBC/NFC FRENCH TERMINOLOGY COMMITTEE

| | |
|---|----------------------------------|
| F.-X. Perreault, (<i>Chairman</i>) | J.-P. Perreault |
| M. Gérard Bessens (<i>ex officio</i>) | |
| G. Harvey (<i>Secretary</i>) | Y.E. Forgues ⁽³⁾ |
| S. Larivière | L.P. Saint-Martin ⁽²⁾ |
| H.C. Nguyen | |

⁽¹⁾Term completed during preparation of the 1985 Code.

⁽²⁾DBR staff who provided assistance to the Committee.

⁽³⁾DBR staff whose involvement with the Committee ended during the preparation of the 1985 Code.

⁽⁴⁾Deceased.

IMPORTANT NOTICE

The Canadian Plumbing Code is subject to periodic review, which may result in amendments being published from time to time. If you wish to be notified of such changes to the Canadian Plumbing Code or if you wish to be placed on the mailing list to receive the **NBC/NFC News**, please complete the reverse side, detach and return.

NBC/NFC News contains explanatory articles and comments on the contents of the National Building Code and the National Fire Code together with announcements of Code changes.

DETACH HERE



The Secretary
Associate Committee on the National Building Code
National Research Council
Ottawa, Ontario
K1A 0R6

Please place my name on the mailing list for future revisions of the Canadian Plumbing Code
and for **NBC/NFC News**.

Name

Street

Apt. No.

City

Prov.

Postal Code

(Please print or type your name and address)

CANADIAN PLUMBING CODE 1985

Issued by the

**Associate Committee on the National Building Code
National Research Council of Canada
Ottawa**

NRCC No. 23176

First Edition 1970
Second Edition 1975
Third Edition 1977
Fourth Edition 1980
Fifth Edition 1985

ISSN 0700-1223

©National Research Council of Canada 1985
World Rights Reserved

Printed in Canada

TABLE OF CONTENTS

| | Page vii |
|----------------------|--|
| PREFACE | |
| SECTION 1 | GENERAL REQUIREMENTS AND ADMINISTRATION |
| Subsection 1.1 | Application |
| Subsection 1.2 | Scope |
| Subsection 1.3 | Definitions and Abbreviations |
| Subsection 1.4 | Equivalents |
| Subsection 1.5 | Plumbing Facilities |
| Subsection 1.6 | Service Connections |
| Subsection 1.7 | Location of Fixtures |
| Subsection 1.8 | Plumbing Drawings and Related Documents |
| Subsection 1.9 | Referenced Documents |
| SECTION 2 | MATERIALS AND EQUIPMENT |
| Subsection 2.1 | General |
| Subsection 2.2 | Fixtures |
| Subsection 2.3 | Traps and Interceptors |
| Subsection 2.4 | Pipe Fittings |
| Subsection 2.5 | Non-Metallic Pipe and Fittings |
| Subsection 2.6 | Ferrous Pipe and Fittings |
| Subsection 2.7 | Non-Ferrous Pipe and Fittings |
| Subsection 2.8 | Jointing Materials |
| Subsection 2.9 | Miscellaneous Materials |
| SECTION 3 | PIPING |
| Subsection 3.1 | Application |
| Subsection 3.2 | Construction and Use of Joints |
| Subsection 3.3 | Joints and Connections |
| Subsection 3.4 | Support of Piping |
| Subsection 3.5 | Protection of Piping |
| Subsection 3.6 | Testing of Drainage and Venting Systems .. |
| Subsection 3.7 | Testing of Potable Water Systems |
| SECTION 4 | DRAINAGE SYSTEMS |
| Subsection 4.1 | Application |
| Subsection 4.2 | Connections to Drainage Systems |
| Subsection 4.3 | Location of Fixtures |
| Subsection 4.4 | Treatment of Sewage and Wastes |
| Subsection 4.5 | Traps |
| Subsection 4.6 | Arrangement of Drainage Piping |
| Subsection 4.7 | Cleanouts |
| Subsection 4.8 | Minimum Slope and Length of Drainage Pipes |
| Subsection 4.9 | Size of Drainage Pipes |
| Subsection 4.10 | Hydraulic Loads |
| SECTION 5 | VENTING SYSTEMS |
| Subsection 5.1 | Vent Pipes for Traps |
| Subsection 5.2 | Single Storey Wet Venting |
| Subsection 5.3 | Multi-Storey Wet Venting |

| | Page |
|--------------------|--|
| Subsection 5.4 | Vent Pipes for Soil-or-Waste Stacks..... 38 |
| Subsection 5.5 | Miscellaneous Vent Pipes 39 |
| Subsection 5.6 | Arrangement of Vent Pipes..... 39 |
| Subsection 5.7 | Minimum Size of Vent Pipes..... 41 |
| Subsection 5.8 | Sizing of Vent Pipes 42 |
| SECTION 6 | POTABLE WATER SYSTEMS 44 |
| Subsection 6.1 | Arrangement of Piping 44 |
| Subsection 6.2 | Protection from Contamination 46 |
| Subsection 6.3 | Size and Capacity of Pipes 47 |
| SECTION 7 | NON-POTABLE WATER SYSTEMS 49 |
| Subsection 7.1 | Connection 49 |
| Subsection 7.2 | Identification 49 |
| Subsection 7.3 | Location 49 |
| APPENDIX A | EXPLANATORY MATERIAL FOR THE CANADIAN PLUMBING CODE 1985.... 51 |
| INDEX | 113 |

PREFACE

The Canadian Plumbing Code contains the requirements for the design and installation of plumbing systems.

Where changes or additions to the previous (1980) edition of this document have been made, the paragraphs affected have been indicated by vertical lines in the margins.

The requirements contained in this Code are supported by explanatory material and diagrams contained in Appendix A, thus leaving the body of the Code consisting of regulatory material only. The first line of each item in the Appendix contains in bold-face type a reference to the definition or requirement to which the explanatory material is applicable. These references have been placed in alphabetical or numerical order to ensure that they are easily found when they are referred to in the text.

The Code is drafted in such a way that it may be adopted or enacted for legal use by any jurisdictional authority in Canada. It is divided into seven Sections, each Section being self-sufficient with a minimum of cross references. A decimal numbering system has been used throughout the Code. The first number indicates the Section of the Code, the second the Subsection in the Section, the third the Article and the fourth the Sentence in the Article. A Sentence (indicated by numbers in brackets) may be further divided into Clauses and Subclauses. They are illustrated as follows:

| | |
|-----------------|------------|
| 4. | Section |
| 4.6 | Subsection |
| 4.6.5. | Article |
| 4.6.5.(1) | Sentence |
| 4.6.5.(1)(c) | Clause |
| 4.6.5.(1)(c)(i) | Subclause |

This edition has been converted to SI units where this is feasible, except for pipe sizes which continue to be expressed in inches. These are nominal dimensions by which pipe is known in the trade and the exact dimension may vary with different pipe materials. Until there is general acceptance of a uniform nominal size for such piping, the pipe size is expressed in inches to avoid confusion.

The Canadian Plumbing Code is published by the National Research Council of Canada and is prepared under the auspices of the Associate Committee on the National Building Code.

It is published separately from but referenced in the National Building Code of Canada. It can thus be adopted for legal use by a municipality or provincial body jointly with or separately from the National Building Code.

Enquiries regarding this document should be directed to: The Secretary, Associate Committee on the National Building Code, National Research Council of Canada, Ottawa, Ontario K1A 0R6.

Ce document est également publié en français.

SECTION 1 GENERAL REQUIREMENTS AND ADMINISTRATION

SUBSECTION 1.1 APPLICATION

1.1.1. This Code applies to the design, construction, extension, alteration, renewal or repair of *plumbing systems*.

1.1.2. The appropriate requirements in the Administrative Requirements for Use with the National Building Code 1985 shall apply to this Code.

SUBSECTION 1.2 SCOPE

- 1.2.1.(1)** This Code specifies the minimum requirements for
- (a) *drainage systems* for water-borne wastes and *storm water for buildings* to the point of connection with public services,
 - (b) *venting systems*,
 - (c) *water service pipes*, and
 - (d) *water distribution systems*.

Scope

SUBSECTION 1.3 DEFINITIONS AND ABBREVIATIONS

1.3.1. Definitions of words and phrases used in this Code that are not included in the list of definitions in this Section shall have the meanings which are commonly assigned to them in the context in which they are used in this Code, taking into account the specialized use of terms by the various trades and professions to which the terminology applies.

Definitions

1.3.2. The words and terms in italics in this Code shall have the following meanings: (See Appendix A.)

Air break means the unobstructed distance between the lowest point of an indirect *drainage system* and the *flood level rim* of the *fixture* into which it discharges. (See A-3.3.11.(2) in Appendix A.)

Air gap means the unobstructed vertical distance through air between the lowest point of a water supply outlet and the *flood level rim* of the *fixture* or device into which the outlet discharges. (See A-6.2.3.(1) in Appendix A.)

Alloyed zinc means an alloy of zinc having the corrosion resistance and physical properties of an alloy containing 0.15 per cent titanium, 0.74 per cent copper and 99.11 per cent zinc, and so tempered as to be capable of being formed into the shape required for a watertight joint.

Backflow means a flowing back or reversal of the normal direction of the flow.

Backflow preventer means a device or a method that prevents *backflow*. (See Appendix A.)

Back-siphonage means *backflow* caused by atmospheric pressure. (See Appendix A.)

Back-siphonage preventer (or vacuum breaker) means a device or a method that prevents *back-siphonage*. (See Appendix A.)

Backwater valve means a *check valve* designed for use in a gravity *drainage system*.

Branch means a *soil-or-waste pipe* connected at its upstream end to the junction of 2 or more *soil-or-waste pipes* or to a *soil-or-waste stack*, and connected at its downstream end to another *branch*, a sump, a *soil-or-waste stack* or a *building drain*. (See A-1.3.2. Drainage System in Appendix A.)

Branch vent means a *vent pipe* that is connected at its lower end to the junction of 2 or more *vent pipes*, and is connected at its upper end either to a *stack vent*, *vent stack* or *header*, or is terminated in open air. (See Appendix A.)

1.3.2.

Building* means any structure used or intended for supporting or sheltering any use or *occupancy*.

Building drain means the horizontal piping, including any vertical *offset* that conducts *sewage*, *clear-water waste* or *storm water* to a *building sewer*. (See A-1.3.2. Drainage System in Appendix A.)

Building sewer means a pipe that is connected to a *building drain* 1 m outside a wall of a *building* and that leads to a public sewer or *private sewage disposal system*.

Building trap means a *trap* that is installed in a *building drain* or *building sewer* to prevent circulation of air between a *drainage system* and a public sewer. (See A-4.5.4.(1) in Appendix A.)

Check valve means a valve that permits flow in one direction but prevents a return flow.

Circuit vent means a *vent pipe* that serves a number of *fixtures* and connects to the *fixture drain* of the most upstream *fixture*. (See Appendix A.)

Cleanout means an access provided in *drainage* and *venting systems* to provide for cleaning and inspection services.

Clear-water waste means waste water with impurity levels that will not be harmful to health and may include cooling water and condensate drainage from refrigeration and air conditioning equipment and cooled condensate from steam heating systems, but does not include *storm water*. (See Appendix A.)

Combined building drain means a *building drain* that is intended to conduct *sewage* and *storm water*.

Combined building sewer means a *building sewer* that is intended to conduct *sewage* and *storm water*.

Combined sewer means a sewer that is intended to conduct *sewage* and *storm water*.

Combustible* means that a material fails to meet the acceptance criteria of CAN4-S114, "Standard Method of Test for Determination of Noncombustibility in Building Materials."

Continuous vent means a *vent pipe* that is an extension of a vertical section of a *branch* or *fixture drain*.

Critical level means the level of submergence at which the *back-siphonage preventer* ceases to prevent *back-siphonage*.

Dead end means a pipe that terminates with a closed fitting.

Developed length means the length along the centre line of the pipe and fittings. (See A-5.6.3.(1) in Appendix A.)

Directly connected means physically connected in such a way that water or gas cannot escape from the connection.

Drainage system means an assembly of pipes, fittings, *fixtures*, *traps* and appurtenances that is used to convey *sewage*, *clear-water waste* or *storm water* to a public sewer or a *private sewage disposal system*, but does not include *subsoil drainage pipes*. (See Appendix A.)

Dual vent means a *vent pipe* that serves 2 *fixtures* and connects at the junction of the *fixture drains*. (See A-1.3.2. Drainage System in Appendix A.)

Dwelling unit* means a *suite* operated as a housekeeping unit used or intended to be used as a domicile by 1 or more persons and usually containing cooking, eating, living, sleeping and sanitary facilities.

Fire Separation* means a construction assembly that acts as a barrier against the spread of fire.

Fixture means a receptacle, appliance, apparatus or other device that discharges *sewage* or *clear-water waste*, and includes a floor drain.

Fixture drain means the pipe that connects a *trap* serving a *fixture* to another part of a *drainage system*. (See Appendix A.)

Fixture outlet pipe means a pipe that connects the waste opening of a *fixture* to the *trap* serving the *fixture*. (See Appendix A.)

Fixture unit (as applying to *drainage systems*) means the unit of measure based on the rate of discharge, time of operation and frequency of use of a *fixture* that expresses the hydraulic load that is imposed by that *fixture* on the *drainage system*.

Fixture unit (as applying to *water distribution systems*) means the unit of measure based on the rate of supply, time of operation and frequency of use of a *fixture* or outlet that expresses the hydraulic load that is imposed by that *fixture* or outlet on the supply system.

Flood level rim means the top edge at which water can overflow from a *fixture* or device. (See A-1.3.2. Back Siphonage in Appendix A.)

Flow control roof drain means a *roof drain* that restricts the flow of *storm water* into the *storm drainage system*.

Fresh air inlet means a *vent pipe* that is installed in conjunction with a *building trap* and terminates outdoors. (See A-4.5.4.(1) in Appendix A.)

Header means a *vent pipe* that connects 2 or more *vent stacks* or *stack vents* to outdoors. (See Appendix A.)

*Indirect service water heater** (see *Service water heater, indirect*).

Indirectly connected means not *directly connected*. (See A-3.3.11.(2) in Appendix A.)

Individual vent means a *vent pipe* that serves 1 *fixture*.

Interceptor means a receptacle that is installed to prevent oil, grease, sand or other materials from passing into a *drainage system*.

Leader means a pipe that is installed to carry *storm water* from a roof to a *storm building drain* or *sewer* or other place of disposal.

Nominally horizontal means at an angle of less than 45° with the horizontal. (See Appendix A.)

Nominally vertical means at an angle of not more than 45° with the vertical. (See Appendix A.)

*Noncombustible** means that a material meets the acceptance criteria of CAN4-S114, "Standard Method of Test for Determination of Non-Combustibility in Building Materials."

*Occupancy** means the use or intended use of a *building* or part thereof for the shelter or support of persons, animals or property.

Offset means the piping that connects the ends of 2 pipes that are parallel. (See Appendix A.)

*Owner** means any person, firm or corporation controlling the property under consideration.

Plumbing contractor means a person, corporation or firm that undertakes to construct, extend, alter, renew or repair any part of a *plumbing system*.

*Plumbing system** means a *drainage system*, a *venting system* and a *water system* or parts thereof. (See Appendix A.)

Potable means safe for human consumption.

*Private sewage disposal system** means a privately owned plant for the treatment and disposal of *sewage* (such as a septic tank with an absorption field).

1.3.2.

Private water supply system means an assembly of pipes, fittings, valves, equipment and appurtenances that supplies water from a private source to a *water distribution system*.

Relief vent means an auxiliary vent which provides additional circulation of air between *drainage systems* and *venting systems*.

Riser means a water distribution pipe that extends through at least 1 full *storey*.

Roof drain means a fitting or device that is installed in the roof to permit *storm water* to discharge into a *leader*.

Roof gutter means an exterior channel installed at the base of a sloped roof to convey *storm water*.

Sanitary building drain means a *building drain* that conducts *sewage*.

Sanitary building sewer means a *building sewer* that conducts *sewage*.

*Sanitary drainage system** means a *drainage system* that conducts *sewage*.

Sanitary sewer means a sewer that conducts *sewage*.

*Service water heater** means a device for heating water for plumbing services.

*Service water heater, indirect** means a *service water heater* that derives its heat from a heating medium such as warm air, steam or hot water.

*Service water heater, storage type** means a *service water heater* with an integral hot water storage tank.

Sewage means any liquid waste other than *clear-water waste* or *storm water*.

Size means the nominal diameter by which a pipe, fitting, *trap* or other similar item is commercially designated.

Soil-or-waste pipe means a pipe in a *sanitary drainage system*.

Soil-or-waste stack means a vertical *soil-or-waste pipe* that passes through 1 or more *storeys*, and includes any *offset* that is part of the stack.

Stack vent means a *vent pipe* that connects the top of a *soil-or-waste stack* to a *header* or open air. (See A-1.3.2. Drainage System in Appendix A.)

*Storage-type service water heater** (see *service water heater, storage type*).

Storey (as applying to plumbing) means the interval between 2 successive floor levels including mezzanine floors that contain plumbing fixtures or between a floor level and roof.

Storm building drain means a *building drain* that conveys *storm water*.

Storm building sewer means a *building sewer* that conveys *storm water*.

Storm drainage system means a *drainage system* that conveys *storm water*.

Storm sewer means a sewer that conveys *storm water*.

Storm water means water that is discharged from a surface as a result of rainfall or snowfall.

Subdrainage system means a *drainage system* that does not drain by gravity to the *building sewer*.

Subsoil drainage pipe means a pipe that is installed underground to intercept and convey subsurface water.

*Suite** means a single room or series of rooms of complementary use, operated under a single tenancy and includes *dwelling units*, individual guest rooms in motels, hotels, boarding houses, rooming houses and dormitories as well as individual stores and individual or complementary rooms for business and personal services occupancies.

Trap means a fitting or device that is designed to hold a liquid seal that will prevent the passage of gas but will not materially affect the flow of a liquid.

Trap arm means that portion of a *fixture drain* between the *trap weir* and the *vent pipe* fitting. (See A-5.6.3.(1) in Appendix A.)

Trap dip means the lowest part of the upper interior surface of a *trap*.

Trap seal depth means the vertical distance between the *trap dip* and the *trap weir*. (See A-2.3.1.(1) in Appendix A.)

Trap standard means the *trap* for a *fixture* that is integral with the support for the *fixture*.

Trap weir means the highest part of the lower interior surface of a *trap*. (See A-2.3.1.(1) and (2) in Appendix A.)

Vacuum breaker (see *back-siphonage preventer*).

Vent pipe means a pipe that is part of a *venting system*.

Vent stack means a *vent pipe* that is connected at its upper end to a *header* or is terminated in open air and that is used to limit pressure differential in a *soil-or-waste stack*. (See A-1.3.2. Drainage System in Appendix A.)

Venting system means an assembly of pipes and fittings that connects a *drainage system* with outside air for circulation of air and the protection of *trap seals* in the *drainage system*. (See A-1.3.2. Drainage System in Appendix A.)

Waste pipe (see *Soil-or-waste pipe*).

Water distribution system means an assembly of pipes, fittings, valves and appurtenances that conveys water from the *water service pipe* or *private water supply system* to water supply outlets, *fixtures*, appliances and devices.

Water service pipe means a pipe that conveys water from a public water main or private water source to the inside of the *building*.

Water system means a *private water supply system*, a *water service pipe*, a *water distribution system* or parts thereof.

Wet vent means a *soil-or-waste pipe* that also serves as a *vent pipe*. (See A-5.8.1. in Appendix A.)

Yoke vent means a *vent pipe* that is connected at its lower end to a *soil-or-waste stack* and at its upper end to a *vent stack* or a *branch vent* that is connected to a *vent stack*.

1.3.3. Abbreviations for the names of organizations or authorities in this Code have the following meanings:

Abbreviations

- ACNBC Associate Committee on the National Building Code
(National Research Council of Canada
Ottawa, Ontario K1A 0R6)
- ANSI American National Standards Institute
(1430 Broadway, New York, New York 10018 U.S.A.)
- ASHRAE . . . American Society of Heating, Refrigerating and
Air-Conditioning Engineers
(1791 Tullie Circle, N.E., Atlanta, Georgia 30329 U.S.A.)
- ASPE American Society of Plumbing Engineers
(15233 Ventura Blvd., Suite 811, Sherman Oakes, California
91403 U.S.A.)
- ASTM American Society for Testing and Materials
(1916 Race Street, Philadelphia, Pennsylvania 19103 U.S.A.)

1.3.3.

- CAN National Standard of Canada designation
(The number following the CAN designation represents the agency under whose auspices the standard is issued.
CAN 1 designates CGA,
CAN 2 designates CGSB,
CAN 3 designates CSA, and
CAN 4 designates ULC.)
- CGA Canadian Gas Association
(55 Scarsdale Road, Don Mills, Ontario M3B 2R3)
- CGSB Canadian General Standards Board
(Jeanne-Mance Building, Tunney's Pasture, Ottawa, Ontario
K1A 1G6)
- CSA Canadian Standards Association
(178 Rexdale Blvd., Rexdale, Ontario M9W 1R3)
- NBC National Building Code of Canada
(National Research Council of Canada
Ottawa, Ontario K1A 0R6)
- ULC Underwriters' Laboratories of Canada
(7 Crouse Road, Scarborough, Ontario M1R 3A9)

1.3.4. Abbreviations of words and phrases in this Code have the following meanings:

- ABS acrylonitrile-butadiene-styrene
cm² square centimetre(s)
CPVC chlorinated poly (vinyl chloride)
° degree(s)
°C degree(s) Celsius
diam diameter
h hour(s)
in. inch(es)
kg/m² kilograms per square metre
kPa kilopascal(s)
L litre(s)
L/s litres per second
m metre(s)
m² square metre(s)
max. maximum
min. minimum
min minute(s)
mm millimetre(s)
NA not applicable
No. number(s)
PVC poly (vinyl chloride)
temp. temperature

SUBSECTION 1.4 EQUIVALENTS

1.4.1. The provisions of this Code are not intended to limit the appropriate use of materials, appliances, systems, equipment, methods of design or construction procedures not specifically authorized herein.

1.4.2. Any person desirous of providing an equivalent to satisfy 1 or more of the requirements of this Code shall submit sufficient evidence to demonstrate that the proposed equivalent will provide the level of performance required by this Code.

1.4.3. Materials, appliances, systems, equipment, methods of design and construction procedures not specifically described herein, or which vary from the specific requirements in this Code, may be used if it can be shown that these alternatives are suitable on the basis of past performances, tests or evaluations.

SUBSECTION 1.5 PLUMBING FACILITIES

1.5.1. Plumbing facilities shall be provided in accordance with Subsection 3.6.4. of Part 3 and Section 9.32 of Part 9 of the National Building Code of Canada 1985.

SUBSECTION 1.6 SERVICE CONNECTIONS

1.6.1.(1) Every *sanitary drainage system* shall be connected to a public *sanitary sewer*, a public *combined sewer* or a *private sewage disposal system*.

Sanitary
drainage
systems

(2) A *combined building drain* shall not be installed. (See Appendix A.)

1.6.2. Every *storm drainage system* shall be connected to a public *storm sewer*, a public *combined sewer* or a designated *storm water disposal location*.

Storm drainage
systems

1.6.3. Every *water distribution system* shall be connected to a public water main or a *private potable water supply system*.

Water
distribution
systems

1.6.4. Piping in any *building* shall be connected to the public services separately from piping of any other *building*, except that an ancillary *building* on the same property may be served by the same service. (See Appendix A.)

Separate
services

SUBSECTION 1.7 LOCATION OF FIXTURES

1.7.1.(1) Plumbing *fixtures* shall not be installed in a room that is not lighted and ventilated in accordance with the appropriate requirements in Parts 3 and 9 of the National Building Code of Canada 1985.

Location of
fixtures

(2) When a water closet is installed in a public washroom it shall be provided with a seat of the open front type.

1.7.2. Every *fixture*, appliance, *interceptor*, *cleanout*, valve, device or piece of equipment shall be so located that it is readily accessible for use, cleaning and maintenance.

Accessibility

SUBSECTION 1.8 PLUMBING DRAWINGS AND RELATED DOCUMENTS

1.8.1.(1) Plumbing drawings and related documents submitted with the application for a plumbing permit shall show

Plumbing
drawings and
related
documents

- (a) the location and *size* of every *building drain* and of every *trap* and *cleanout* fitting that is on a *building drain*,
- (b) the *size* and location of every *soil-or-waste pipe*, *trap* and *vent pipe*, and
- (c) a layout of the *potable water distribution system*, including pipe *sizes* and valves.

SUBSECTION 1.9 REFERENCED DOCUMENTS

1.9.1. In case of conflict between the provisions of this Code and those of a referenced document, the provisions of this Code shall govern.

Referenced
documents

1.9.2.

1.9.2. Unless otherwise specified herein, the documents referenced in this Code shall include all amendments, revisions and supplements effective to 30 June 1984.

1.9.3. Where standards are referenced in this Code, they shall be the editions designated in Table 1.9.A.

Table 1.9.A.
Forming part of Article 1.9.3.

| DOCUMENTS REFERENCED IN THE CANADIAN PLUMBING CODE 1985 | | | |
|--|------------------------|---|------------------------|
| Issuing Agency | Document Number | Title of Document | Code Reference |
| ANSI | B16.3-1977 | Malleable-Iron Threaded Fittings, 150 and 300 lb | 2.6.6.(1) |
| ANSI | B16.4-1977 | Cast-Iron Threaded Fittings, 125 and 250 lb | 2.6.5.(1) |
| ANSI | B16.12-1983 | Cast-Iron Threaded Drainage Fittings | 2.6.3.(1) |
| ANSI | B16.15-1978 | Cast Bronze Threaded Fittings, Class 125 and 250 | 2.7.3.(1) |
| ANSI | B16.18-1984 | Cast Copper Alloy Solder-Joint Pressure Fittings | 2.7.6.(1) 2.7.6.(2) |
| ANSI | B16.22-1980 | Wrought Copper and Copper Alloy Solder-Joint Pressure Fittings | 2.7.6.(1) |
| ANSI | B16.24-1979 | Bronze Pipe Flanges and Flanged Fittings, 150 and 300 lb | 2.7.2. |
| ANSI | B16.26-1983 | Cast Copper Alloy Fittings for Flared Copper Tubes | 2.7.7.(1) 2.7.7.(2) |
| ANSI | B16.29-1980 | Wrought Copper and Wrought Copper Alloy Solder-Joint Drainage Fittings-DWV | 2.7.5.(1) |
| ANSI/AWWA | C104/A21.4-80 | Cement-Mortar Lining for Ductile-Iron and Gray-Iron Pipe and Fittings for Water | 2.6.4.(2) |
| ANSI/AWWA | C106/A21.6-80 | Gray-Iron Pipe Centrifugally Cast in Metal Molds, for Water or Other Liquids | 2.6.4.(1) |
| ANSI/AWWA | C110-77 | Gray-Iron and Ductile-Iron Fittings, 3 in. Through 48 in., for Water and Other Liquids | 2.6.4.(3) |
| ANSI/AWWA | C111/A21.11-80 | Rubber Gasket Joints for Cast-Iron and Ductile-Iron Pressure Pipe and Fittings | 2.6.4.(4) |
| ANSI/AWWA | C151/A21.51-81 | Ductile-Iron Pipe, Centrifugally Cast in Metal Molds or Sand-Lined Molds for Water or Other Liquids | 2.6.4.(1) |
| Column 1 | 2 | 3 | 4 |

Table 1.9.A. (Cont'd)

| Issuing Agency | Document Number | Title of Document | Code Reference |
|----------------|-----------------|---|----------------|
| ASTM | A53-84 | Pipe, Steel, Black and Hot-Dipped, Zinc-Coated Welded and Seamless | 2.6.7.(4) |
| ASTM | B32-83 | Solder Metal | 2.8.3.(2) |
| ASTM | B42-84 | Seamless Copper Pipe, Standard Sizes | 2.7.1.(1) |
| ASTM | B43-84 | Seamless Red Brass Pipe, Standard Sizes | 2.7.1.(2) |
| ASTM | B88-83 | Seamless Copper Water Tube | 2.7.4.(1) |
| ASTM | B306-83 | Copper Drainage Tube (DWV) | 2.7.4.(1) |
| ASTM | D2466-78 | Poly (Vinyl Chloride) (PVC) Plastic Pipe Fittings, Schedule 40 | 2.5.6.(2) |
| ASTM | D2467-76a | Socket-Type Poly (Vinyl Chloride) (PVC) Plastic Pipe Fittings, Schedule 80 | 2.5.6.(2) |
| ASTM | D2564-80 | Solvent Cements for Poly (Vinyl Chloride) (PVC) Plastic Pipe and Fittings | 2.5.6.(3) |
| ASTM | D2609-74 | Plastic Insert Fittings for Polyethylene (PE) Plastic Pipe | 2.5.5.(3) |
| ASTM | D3261-84 | Butt Heat Fusion Polyethylene (PE) Plastic Fittings for Polyethylene (PE) Plastic Pipe and Tubing | 2.5.5.(4) |
| CGSB | 34-GP-1M-1976 | Pipe, Asbestos Cement, Pressure | 2.5.2.(1) |
| CGSB | 34-GP-9M-1975 | Pipe, Asbestos Cement, Sewer | 2.5.1.(2) |
| CGSB | 34-GP-22M-1976 | Pipe, Asbestos Cement, Drain | 2.5.1.(1) |
| CGSB | 34-GP-23M-1976 | Pipe, Asbestos Cement, Sewer, House Connection | 2.5.1.(2) |
| CGSB | 77-GP-1M-1977 | Caulking Compound, Cementitious Type, Cold Applied, for Pipe Joints | 2.8.2. |
| CGA | CAN1-4.4-M80 | Temperature, Pressure, Temperature and Pressure Relief Valves and Vacuum Relief Valves | 2.9.10. |
| CSA | A60.1-M1976 | Vitrified Clay Pipe | 2.5.4.(1) |
| CSA | A60.3-M1976 | Vitrified Clay Pipe Joints | 2.5.4.(2) |
| CSA | A257.1-M1982 | Concrete Sewer, Storm Drain and Culvert Pipe | 2.5.3.(1) |
| CSA | CAN3-B45.0-M81 | General Requirements for Plumbing Fixtures | 2.2.2.(1) |
| CSA | A257.2-M1982 | Reinforced Concrete Culvert, Storm Drain and Sewer Pipe | 2.5.3.(1) |
| Column 1 | 2 | 3 | 4 |

Table 1.9.A. (Cont'd)

| Issuing Agency | Document Number | Title of Document | Code Reference |
|----------------|-----------------|---|------------------------|
| CSA | A257.3-M1982 | Joints for Circular Concrete Sewer and Culvert Pipe Using Rubber Gaskets | 2.5.3.(2) |
| CSA | CAN3-B45.0-M81 | General Requirements for Plumbing Fixtures | 2.2.2.(1) |
| CSA | CAN3-B45.1-M81 | Vitreous China Plumbing Fixtures | 2.2.2.(2) |
| CSA | CAN3-B45.2-M81 | Enamelled Cast Iron Plumbing Fixtures | 2.2.2.(3) |
| CSA | CAN3-B45.3-M81 | Porcelain Enamelled Steel Plumbing Fixtures | 2.2.2.(4) |
| CSA | CAN3-B45.4-M81 | Stainless Steel Plumbing Fixtures | 2.2.2.(5) |
| CSA | CAN3-B45.5-M81 | Plastic Plumbing Fixtures | 2.2.2.(6) |
| CSA | B64.0-1976 | Definitions, General Requirements, and Test Methods for Vacuum Breakers and Backflow Preventers | 2.9.9.(1) |
| CSA | B64.1.1-1976 | Vacuum Breakers — Atmospheric Type | 2.9.9.(1) |
| CSA | B64.1.2-1979 | Vacuum Breakers — Pressure Type | 2.9.9.(1) |
| CSA | B64.2-1976 | Vacuum Breakers — Hose-Connection Type | 2.9.9.(1) |
| CSA | B64.3-1976 | Backflow Preventers — Superior-Pressure-Principle Type | 2.9.9.(1) |
| CSA | B64.4-1976 | Backflow Preventers — Reduced-Pressure-Principle Type | 2.9.9.(1) |
| CSA | B64.5-1976 | Backflow Preventers — Double-Check-Valve Type | 2.9.9.(1) |
| CSA | B67-1972 | Lead Service Pipe, Waste Pipe, Traps, Bends and Accessories | 2.7.8.(1) 2.8.3.(1) |
| CSA | B70-M1978 | Cast Iron Soil Pipe, Fittings and Methods of Joining | 2.6.1.(1) 2.6.2. |
| CSA | B125-1975 | Plumbing Fittings | 2.9.6. 2.9.9.(2) |
| CSA | B127.1-M1977 | Components for Use in Asbestos Cement, Drain, Waste and Vent Systems | 2.5.1.(1) |
| CSA | B127.2-M1977 | Components for Use in Asbestos Cement Building Sewer Systems | 2.5.1.(2) |
| Column 1 | 2 | 3 | 4 |

Table 1.9.A. (Cont'd)

| Issuing Agency | Document Number | Title of Document | Code Reference |
|----------------|-----------------|--|-------------------------|
| CSA | B137.1-M1983 | Polyethylene Pipe, Tubing and Fittings for Cold Water Pressure Services | 2.5.5.(1) |
| CSA | B137.3-M1981 | Rigid Poly (Vinyl Chloride) (PVC) Pipe for Pressure Applications | 2.5.6.(1) |
| CSA | B137.6-M1983 | CPVC Pipe, Tubing and Fittings for Hot and Cold Water Distribution Systems | 2.5.7.(1) |
| CSA | B137.8-M1977 | Polybutylene (PB) Piping for Hot and Cold Water Distribution Systems | 2.5.8. |
| CSA | B158.1-1976 | Cast Brass Solder Joint Drainage, Waste and Vent Fittings | 2.7.5.(1) 2.9.1. |
| CSA | B181.1-1973 | Acrylonitrile-Butadiene-Styrene Drain, Waste and Vent (ABS-DWV) Pipe and Pipe Fittings | 2.5.9.(1) 2.5.10.(1) |
| CSA | B181.2-1973 | Poly (Vinyl Chloride) Drain, Waste and Vent Pipe and Pipe Fittings | 2.5.9.(1) 2.5.10.(1) |
| CSA | B182.1-M1983 | Plastic Drain and Sewer Pipe and Pipe Fittings | 2.5.9.(1) |
| CSA | B242-M1980 | Groove and Shoulder Type Mechanical Pipe Couplings | 2.9.4. |
| CSA | B272-M1978 | Prefabricated Self-Sealing Vent Flashings | 2.9.11.(2) |
| CSA | CAN3-G401-M81 | Corrugated Steel Pipe Products | 2.6.8.(1) |
| ULC | CAN4-S114-M80 | Standard Method of Test for Determination of Non-Combustibility in Building Materials | 1.3.2. |
| Column 1 | 2 | 3 | 4 |

SECTION 2 MATERIALS AND EQUIPMENT

SUBSECTION 2.1 GENERAL

2.1.1. All materials, systems and equipment installed to meet the requirements of this Code shall be free from defects and possess the necessary characteristics to perform their intended functions when installed.

Defects in products and materials

2.1.2. Where unusual conditions exist such as excessively corrosive soil or water, only materials suited for use in such locations shall be used.

Exposure of materials

2.1.3.(1) Used materials and equipment, including fixtures, shall not be reused unless they meet the requirements of this Code for new materials and equipment and are otherwise satisfactory for their intended use.

Restriction on re-use

2.1.3.

(2) Materials and equipment that have been used for a purpose other than the distribution of *potable* water shall not be subsequently used in a *potable water system*.

Identification

2.1.4. Every length of pipe and every fitting shall have cast, stamped or indelibly marked on it the maker's name or mark and the weight or class or quality of the product, or it shall be marked in accordance with the relevant standard, and such markings shall be visible after installation.

2.1.5. Where the term pipe or piping is used, it shall also apply to tube or tubing unless otherwise stated.

2.1.6. Piping, fittings and joints used in pressure sewer, forcemain or sump pump discharge applications shall be capable of withstanding at least 1½ times the maximum potential pressure.

SUBSECTION 2.2 FIXTURES

2.2.1. Every *fixture* shall have a smooth, hard, corrosion-resistant surface free from flaws and blemishes that may interfere with cleaning.

2.2.2.(1) Every *fixture* shall conform to CAN3-B45.0, "General Requirements for Plumbing Fixtures" as applicable.

(2) Every vitreous china *fixture* shall conform to CAN3-B45.1, "Vitreous China Plumbing Fixtures."

(3) Every enamelled cast iron *fixture* shall conform to CAN3-B45.2, "Enamelled Cast Iron Plumbing Fixtures."

(4) Every porcelain enamelled steel *fixture* shall conform to CAN3-B45.3, "Porcelain Enamelled Steel Plumbing Fixtures."

(5) Every stainless steel *fixture* shall conform to CAN3-B45.4, "Stainless Steel Plumbing Fixtures."

(6) Every plastic *fixture* shall conform to CAN3-B45.5, "Plastic Plumbing Fixtures."

Shower
receptors

2.2.3.(1) Every shower receptor shall be constructed and arranged so that water cannot leak through the walls or floor.

(2) Not more than 6 shower heads shall be served by a single shower drain.

(3) Where 2 or more shower heads are served by a shower drain, the floor shall be sloped and the drain located so that water from one head cannot flow over the area that serves another head. (See Appendix A.)

(4) Except for column showers, when a battery of shower heads is installed, the horizontal distance between 2 adjacent shower heads shall be at least 750 mm.

2.2.4. A dishwashing sink and a food preparation sink shall not have concealed overflows. (See Appendix A.)

SUBSECTION 2.3 TRAPS AND INTERCEPTORS

Traps

2.3.1.(1) Every *trap* shall

(a) have a *trap seal depth* of at least 38 mm,

(b) be so designed that failure of the seal walls will cause exterior leakage, and

(c) have a water seal that does not depend on the action of moving parts.

(See Appendix A.)

- (2) Every *trap* that serves a lavatory, a sink or a laundry tray shall
 - (a) be provided with a *cleanout* plug located at the lowest point of the *trap* and of the same material as the *trap*, except that a cast-iron *trap* shall be provided with a brass *cleanout* plug, or
 - (b) be designed so that part of the *trap* can be completely removed by screwed connections for cleaning purposes.

(See Appendix A.)

- (3) A bell *trap* shall not be installed in a *drainage system*. (See Appendix A.)

(4) A drum *trap* shall not be used as a *fixture trap* unless required to serve as an *interceptor* and access for servicing is provided.

2.3.2.(1) Every *interceptor* shall be designed so that it can be readily cleaned.

Interceptors

(2) Every grease *interceptor* shall be designed so that it does not become air bound and it shall not have a water jacket.

SUBSECTION 2.4 PIPE FITTINGS

2.4.1.(1) A T fitting shall not be used in a *drainage system* except to connect a *vent pipe*.

T and cross fittings

- (2) A cross fitting shall not be used in a *drainage system*.

(See Appendix A.)

2.4.2.(1) A single or double sanitary T fitting shall not be used in a *nominally horizontal soil-or-waste pipe*, except that a single sanitary T fitting may be used to connect a *vent pipe*.

- (2) A double sanitary T fitting shall not be used to connect the *trap arms* of
 - (a) back outlet water closets installed back-to-back, or
 - (b) 2 urinals where no *cleanout* fitting is provided above the connection.

(See Appendix A.)

2.4.3. A ¼ bend of 4 in. in *size* or less that has a centre-line radius that is less than the *size* of the pipe shall not be used to join 2 *soil-or-waste pipes*.

Quarter bend

2.4.4. A sisson fitting shall not be installed in a *nominally horizontal soil-or-waste pipe*.

Sisson fitting

SUBSECTION 2.5 NON-METALLIC PIPE AND FITTINGS

(For a summary of pipe applications see Appendix A.)

2.5.1.(1) Except as provided in Sentence (2), asbestos-cement pipe and its fittings for use in a drain, waste or vent system shall conform to

Asbestos-cement drainage pipe and fittings

- (a) CGSB 34-GP-22M, "Pipe, Asbestos Cement, Drain," or
- (b) CSA B127.1, "Components for Use in Asbestos Cement Drain, Waste and Vent Systems."

(2) Asbestos-cement pipe and fittings used underground either outside a *building* or under a *building* shall conform to Sentence (1) or to

- (a) CGSB 34-GP-9M, "Pipe, Asbestos Cement, Sewer,"
- (b) CGSB 34-GP-23M, "Pipe, Asbestos Cement, Sewer, House Connection," or
- (c) CSA B127.2, "Components for Use in Asbestos Cement Building Sewer Systems."

2.5.2.(1) Asbestos-cement water pipe, couplings and bends shall conform to CGSB 34-GP-1, "Pipe, Asbestos Cement, Pressure."

Asbestos-cement water pipe and fittings

2.5.2.

(2) Asbestos-cement water pipe shall not be used above ground.

Concrete pipe

2.5.3.(1) Concrete pipe shall conform to CSA A257.1, "Concrete Sewer, Storm Drain and Culvert Pipe" or CSA A257.2, "Reinforced Concrete Culvert, Storm Drain and Sewer Pipe" of CSA Series A257, "Standards for Concrete Pipe."

(2) Gasketed joints shall conform to CSA A257.3, "Joints for Circular Concrete Sewer and Culvert Pipe Using Rubber Gaskets" of CSA Series A257, "Standards for Concrete Pipe."

(3) Where joints are required in concrete pipe under a *building*, they shall be gasketed.

(4) Concrete fittings fabricated on the site from lengths of pipe shall not be used. (See Appendix A.)

(5) Concrete pipe shall not be used inside a *building*.

3.5.4.(1) Vitrified clay pipe and fittings shall conform to CSA A60.1, "Vitrified Clay Pipe."

(2) Couplings and joints for vitrified clay pipe shall conform to CSA A60.3, "Vitrified Clay Pipe Joints."

(3) Vitrified clay pipe and fittings shall not be used except for an underground part of a *drainage system*.

Plastic pipe and fittings

2.5.5.(1) Polyethylene water pipe shall conform to CSA B137.1, "Polyethylene Pipe, Tubing and Fittings for Cold Water Pressure Services."

(2) Polyethylene water pipe shall not be used except for a *water service pipe*.

(3) Insert fittings for use with polyethylene pipe shall conform to ASTM D2609, "Plastic Insert Fittings for Polyethylene (PE) Plastic Pipe."

(4) Butt fusion fittings for polyethylene pipe shall conform to ASTM D3261, "Butt Heat Fusion Polyethylene (PE) Plastic Fittings for Polyethylene (PE) Plastic Pipe and Tubing."

2.5.6.(1) PVC water pipe shall conform to CSA B137.3, "Rigid Poly (Vinyl Chloride) (PVC) Pipe for Pressure Applications."

(2) PVC water pipe fittings shall conform to ASTM D2466, "Poly (Vinyl Chloride) (PVC) Plastic Pipe Fittings, Schedule 40" or ASTM D2467, "Socket-Type Poly (Vinyl Chloride) (PVC) Plastic Pipe Fittings, Schedule 80."

(3) PVC solvent cements shall conform to ASTM D2564, "Solvent Cements for Poly (Vinyl Chloride) (PVC) Plastic Pipe and Fittings."

(4) PVC water pipe and fittings in Sentences (1) and (2) shall not be used in a hot *water system*.

2.5.7.(1) CPVC hot and cold water pipe, fittings and solvent cements shall conform to CSA B137.6, "CPVC Pipe, Tubing and Fittings for Hot and Cold Water Distribution Systems."

(2) The design temperature and design pressure of a CPVC piping system shall conform to Table 2.5.A.

2.5.8. Polybutylene pipe and its associated fittings shall conform to CSA B137.8, "Polybutylene (PB) Piping for Hot and Cold Water Distribution Systems."

Table 2.5.A.
Forming Part of Sentence 2.5.7.(2)

| MAXIMUM PERMITTED PRESSURE FOR CPVC PIPING AT VARIOUS TEMPERATURES | |
|---|----------------------------------|
| Maximum Temperature of Water, °C | Maximum Permitted Pressures, kPa |
| 10 | 3 350 |
| 20 | 2 900 |
| 30 | 2 500 |
| 40 | 2 100 |
| 50 | 1 700 |
| 60 | 1 300 |
| 70 | 1 000 |
| 80 | 700 |
| 90 | 500 |
| 100 | 400 |
| Column 1 | 2 |

2.5.9.(1) Plastic pipe, fittings and solvent cement used underground outside a *building* or under a *building* in a *drainage system* shall conform to

- (a) CSA B181.1, "Acrylonitrile-Butadiene-Styrene Drain, Waste and Vent (ABS-DWV) Pipe and Pipe Fittings,"
- (b) CSA B181.2, "Poly (Vinyl Chloride) Drain, Waste and Vent Pipe and Pipe Fittings," or
- (c) CSA B182.1, "Plastic Drain and Sewer Pipe and Pipe Fittings."

2.5.10.(1) Plastic pipe, fittings and solvent cement used inside or under a *building* in a *drainage* or *venting system* shall conform to

- (a) CSA B181.1, "Acrylonitrile-Butadiene-Styrene Drain, Waste and Vent (ABS-DWV) Pipe and Pipe Fittings," or
- (b) CSA B181.2, "Poly (Vinyl Chloride) Drain, Waste and Vent Pipe and Pipe Fittings."

(2) Requirements for *combustible* piping in relation to fire safety shall conform to Sentences 3.1.4.5.(5) and 3.1.7.2.(2) of Part 3 and Articles 9.10.9.10. and 9.10.9.26. of Part 9 of the National Building Code of Canada 1985.

(3) Where *noncombustible* piping pierces a *fire separation* or a *fire stop*, the requirements of fire stopping of Subsection 3.1.9. of Part 3 and Articles 9.10.9.9. and 9.10.15.10. of Part 9 of the National Building Code of Canada 1985 shall apply.

SUBSECTION 2.6 FERROUS PIPE AND FITTINGS

(For summary of pipe applications see Appendix A.)

2.6.1.(1) Drainage piping, vent piping and fittings made of cast iron shall conform to CSA B70, "Cast Iron Soil Pipe, Fittings and Methods of Joining."

Cast-iron soil pipe and fittings

(2) Cast-iron soil pipe and fittings shall not be used in a *water system*.

2.6.2. Cast-iron fittings designed for use with asbestos-cement pipe for drainage purposes shall conform to the applicable requirements of CSA B70, "Cast Iron Soil Pipe, Fittings and Methods of Joining."

2.6.3.(1) Threaded cast-iron drainage fittings shall conform to ANSI B16.12, "Cast-Iron Threaded Drainage Fittings."

Threaded cast-iron drainage fittings

(2) Threaded cast-iron drainage fittings shall not be used in a *water system*.

2.6.4.

Cast-iron water pipe

- 2.6.4.(1)** Cast iron water pipes shall conform to
- (a) ANSI/AWWA C106/A21.6, "Gray-Iron Pipe Centrifugally Cast in Metal Molds, for Water or Other Liquids," or
 - (b) ANSI/AWWA C151/A21.51, "Ductile-Iron Pipe, Centrifugally Cast in Metal Molds or Sand-Lined Molds, for Water or Other Liquids."
- (2) Cement mortar lining for cast-iron water pipes shall conform to ANSI/AWWA C104/A21.4, "Cement-Mortar Lining for Ductile-Iron and Gray-Iron Pipe and Fittings for Water."
- (3) Cast-iron fittings for cast-iron or ductile-iron water pipes shall conform to ANSI/AWWA C110, "Gray-Iron and Ductile-Iron Fittings, 3-in. Through 48-in. for Water and Other Liquids."
- (4) Rubber gasket joints for cast-iron and ductile-iron pressure pipe for water piping shall conform to ANSI/AWWA C111/A21.11, "Rubber-Gasket Joints for Cast-Iron and Ductile-Iron Pressure Pipe and Fittings."

Cast-iron screwed water fittings

- 2.6.5.(1)** Screwed cast-iron water fittings shall conform to ANSI B16.4, "Cast-Iron Threaded Fittings, 125 and 250 lb."
- (2) Screwed cast-iron water fittings used in a *water system* shall be cement-mortar lined or galvanized.
- (3) Screwed cast-iron water fittings shall not be used in a *drainage system*.

Malleable iron screwed water fittings

- 2.6.6.(1)** Screwed malleable iron water fittings shall conform to ANSI B16.3, "Malleable-Iron Threaded Fittings 150 and 300 lb."
- (2) Screwed malleable iron water fittings used in a *water system* shall be cement-mortar lined or galvanized.
- (3) Screwed malleable iron water fittings shall not be used in a *drainage system*.

Steel pipe

- 2.6.7.(1)** Except as provided in Sentences (2) and (3), welded and seamless steel pipe shall not be used in a *plumbing system*.
- (2) Galvanized steel pipe may be used in a *drainage system* or a *venting system* above ground inside a *building*.
- (3) Galvanized steel pipe shall not be used in a *water distribution system* except
- (a) in *buildings* of industrial occupancy as described in the National Building Code of Canada 1985, or
 - (b) for the repair of existing galvanized steel piping systems.
- (See Appendix A.)
- (4) Galvanized steel pipe shall conform to ASTM A53, "Pipe, Steel, Black and Hot Dipped, Zinc-Coated, Welded and Seamless."

Corrugated steel pipe

- 2.6.8.(1)** Corrugated steel pipe and couplings shall conform to CAN3-G401, "Corrugated Steel Pipe Products."
- (2) Corrugated steel pipe shall only be used underground outside a *building* in a *storm drainage system*.
- (3) Couplings for corrugated steel pipe shall be constructed so that when installed they shall
- (a) maintain the pipe alignment,
 - (b) resist the separation of adjoining lengths of pipe,
 - (c) prevent root penetration, and
 - (d) prevent the infiltration of surrounding material.

2.6.9. A sheet metal *leader* shall not be used except above ground outside a *building*. Sheet metal leader

SUBSECTION 2.7 NON-FERROUS PIPE AND FITTINGS

(For summary of pipe applications see Appendix A.)

2.7.1.(1) Copper pipe shall conform to ASTM B42, "Seamless Copper Pipe, Standard Sizes." Copper and brass pipe

(2) Brass pipe shall conform to ASTM B43, "Seamless Red Brass Pipe, Standard Sizes."

2.7.2. Brass or bronze pipe flanges and flanged fittings shall conform to ANSI B16.24, "Bronze Pipe Flanges and Flanged Fittings, 150 and 300 lb." Brass or bronze flanges and flanged fittings

2.7.3.(1) Brass or bronze threaded water fittings shall conform to ANSI B16.15, "Cast Bronze Threaded Fittings, Class 125 and 250." Brass or bronze threaded water fittings

(2) Brass or bronze threaded water fittings shall not be used in a *drainage system*.

2.7.4.(1) Copper tube shall conform to Copper tube
 (a) ASTM B88, "Seamless Copper Water Tube," or
 (b) ASTM B306, "Copper Drainage Tube (DWV)."

(2) Except as provided in Sentence (3), the use of copper tube shall conform to Table 2.7.A.

Table 2.7.A.
Forming Part of Article 2.7.4.

| Type of Copper Tube or Pipe | PLUMBING PURPOSES | | | | | | | |
|-----------------------------|--------------------|---------------------------|--------------|----------------|-----------------|--------------|----------------|--------------|
| | Water Service Pipe | Water Distribution System | | Building Sewer | Drainage System | | Venting System | |
| | | Under-ground | Above-ground | | Under-ground | Above-ground | Under-ground | Above-ground |
| K & L hard | N | N | P | P | P | P | P | P |
| K & L soft | P | P | P | N | N | N | N | N |
| M hard | N | N | P | N | N | P | N | P |
| M soft | N | N | N | N | N | N | N | N |
| DWV | N | N | N | N | N | P | N | P |
| Column 1 | 2 | 3 | 4 | 5 | 6 | 7 | 8 | 9 |

P—Permitted N—Not Permitted

(3) Copper tube shall not be used for the *fixture drain* or the portion of the *vent* below the flood level rim of a flush valve-operated urinal.

2.7.5.(1) Solder-joint fittings for *drainage systems* shall conform to Solder-joint drainage fittings
 (a) CSA B158.1, "Cast Brass Solder Joint Drainage, Waste and Vent Fittings," or
 (b) ANSI B16.29, "Wrought Copper and Wrought Copper Alloy Solder-Joint Drainage Fittings—DWV."

(2) Solder-joint fittings for *drainage systems* shall not be used in a *water system*.

2.7.6.(1) Except as provided in Sentence (2), solder-joint fittings for *water systems* shall conform to Solder-joint water fittings

(a) ANSI B16.18, "Cast Copper Alloy Solder-Joint Pressure Fittings," or

2.7.6.

(b) ANSI B16.22, "Wrought Copper and Copper Alloy Solder-Joint Pressure Fittings."

(2) Solder-joint fittings for *water systems* not made by casting or the wrought process shall conform to the applicable requirements of ANSI B16.18, "Cast Copper Alloy Solder-Joint Pressure Fittings."

Flared-joint
water fittings

2.7.7.(1) Flared-joint fittings for copper tube *water systems* shall conform to ANSI B16.26, "Cast Copper Alloy Fittings for Flared Copper Tubes."

(2) Flared-joint fittings for copper tube *water systems* not made by casting shall conform to the applicable requirements of ANSI B16.26, "Cast Copper Alloy Fittings for Flared Copper Tubes."

Lead waste pipe
and bends

2.7.8.(1) Lead *waste pipe* and fittings shall conform to CSA B67, "Lead Service Pipe, Waste Pipe, Traps, Bends and Accessories."

(2) When there is a change in *size* of a lead closet bend, the change shall be in the vertical section of the bend or made in such a manner that there shall be no retention of liquid in the bend.

(3) Lead *waste pipe* and fittings shall not be used in a *water system* or for a *building sewer*.

SUBSECTION 2.8 JOINTING MATERIALS

Cement jointing
mortar

2.8.1. Cement mortar for jointing shall be a mixture of equal parts of clean, sharp mortar sand and portland cement.

2.8.2. Cold caulking compounds shall conform to CGSB 77-GP-1, "Caulking Compound, Cementitious Type, Cold Applied, for Pipe Joints."

Solder and
caulking lead

2.8.3.(1) Wiping solder and caulking lead shall conform to CSA B67, "Lead Service Pipe, Waste Pipe, Traps, Bends and Accessories."

(2) Solders for solder joint fittings shall conform to ASTM B32, "Solder Metal" in accordance with the recommended use.

SUBSECTION 2.9 MISCELLANEOUS MATERIALS

Brass floor
flanges

2.9.1. Brass floor flanges shall conform to CSA B158.1, "Cast Brass Solder Joint Drainage, Waste and Vent Fittings."

Bolts, nuts, etc.

2.9.2.(1) Every screw, bolt, nut and washer shall be of brass when used

- to connect a water closet to a water closet flange,
- to anchor the water closet flange to the floor, or
- to anchor the water closet to the floor.

Cleanout fittings

2.9.3.(1) Every plug, cap, nut or bolt that is intended to be removable from a ferrous fitting shall be of a non-ferrous material.

(2) A *cleanout* fitting that as a result of normal maintenance operations cannot withstand the physical stresses of removal and reinstallation or cannot ensure a gas-tight seal shall not be installed.

2.9.4. Groove and shoulder type mechanical pipe couplings shall conform to CSA B242, "Groove and Shoulder Type Mechanical Pipe Couplings."

Saddle hub

2.9.5. A saddle hub or fitting shall not be installed in *drainage, venting* or *water systems*. (See Appendix A.)

Supply and
waste fittings

2.9.6. Supply and waste fittings shall conform to CSA B125, "Plumbing Fittings."

- 2.9.7.(1)** Every direct flush valve shall
- (a) open fully and close positively under service pressure,
 - (b) complete its cycle of operation automatically,
 - (c) be provided with a means of regulating the volume of water that it discharges, and
 - (d) be provided with a *vacuum breaker* unless the fixture is designed so that back-siphonage cannot occur.
- Direct flush valve
- 2.9.8.(1)** The orifice of every drinking fountain bubbler shall
- (a) be of the shielded type, and
 - (b) direct the water upward at an angle of approximately 45°.
- (2) Every drinking fountain bubbler shall include a means of regulating the flow to the orifice.
- (3) Bubblers shall be installed only on drinking fountains. (See Appendix A.)
- Drinking fountain bubblers
- 2.9.9.(1)** Except as provided in Sentence (2), *back-siphonage preventers* and *backflow preventers* shall conform to
- (a) CSA B64.0, "Definitions, General Requirements, and Test Methods for Vacuum Breakers and Backflow Preventers,"
 - (b) CSA B64.1.1, "Vacuum Breakers – Atmospheric Type,"
 - (c) CSA B64.1.2, "Vacuum Breakers – Pressure Type,"
 - (d) CSA B64.2, "Vacuum Breakers – Hose-Connection Type,"
 - (e) CSA B64.3, "Backflow Preventers – Superior – Pressure – Principle Type,"
 - (f) CSA B64.4, "Backflow Preventers – Reduced – Pressure – Principle Type," or
 - (g) CSA B64.5, "Backflow Preventers – Double-Check-Valve Type."
- (See Appendix A.)
- Back-siphonage preventers
- (2) *Back-siphonage preventers* for tank type water closets shall conform to CSA B125, "Plumbing Fittings."
- 2.9.10.** Temperature relief, pressure relief, combined temperature and pressure relief and vacuum relief valves shall conform to CAN1-4.4, "Temperature, Pressure, Temperature and Pressure Relief Valves and Vacuum Relief Valves."
- Relief valves
- 2.9.11.(1).** Flashing fabricated on-site for *vent pipes* shall be fabricated from
- (a) copper sheet at least 0.33 mm thick,
 - (b) aluminum sheet at least 0.61 mm thick,
 - (c) *alloyed zinc* sheet at least 0.35 mm thick,
 - (d) lead sheet at least 2.16 mm thick,
 - (e) galvanized steel sheet at least 0.41 mm thick, or
 - (f) polychloroprene (neoprene) at least 2.89 mm thick.
- Vent pipe flashings
- (2) Prefabricated flashing for *vent pipes* shall conform to CSA B272, "Prefabricated Self-Sealing Vent Flashings."
- (See Article 5.6.5. for location of vent pipe terminals.)

SECTION 3 PIPING

SUBSECTION 3.1 APPLICATION

3.1.1. This Section applies to the construction and use of joints and connections, and the arrangement, protection, support and testing of piping.

3.2.1.

SUBSECTION 3.2 CONSTRUCTION AND USE OF JOINTS

Caulked lead
drainage joints

3.2.1.(1) Every caulked lead drainage joint shall be firmly packed with oakum and tightly caulked with lead to a depth of at least 25 mm.

(2) No paint, varnish or other coating shall be applied on the lead until after the joint has been tested.

(3) Caulked lead drainage joints shall not be used except for cast-iron pipe in a *drainage system* or *venting system*, or between such pipe and

- (a) other ferrous pipe,
- (b) brass and copper pipe,
- (c) a caulking ferrule, or
- (d) a *trap standard*.

(4) A length of hub and spigot pipe and pipe fittings in a *drainage system* shall be installed with the hub at the upstream end.

3.2.2.(1) Wiped joints shall not be used except for sheet lead or lead pipe, or between such pipe and copper pipe or a ferrule.

(2) Every wiped joint in straight pipe shall

- (a) be made of solder,
- (b) have an exposed surface on each side of the joint at least 19 mm wide, and
- (c) be at least 10 mm thick at the thickest part.

(3) Every wiped flanged joint shall be reinforced with a lead flange that is at least 19 mm wide.

Screwed joints

3.2.3.(1) In making a screwed joint the ends of the pipe shall be reamed or filed out to the size of the bore and all chips and cuttings shall be removed.

(2) No pipe-joint cement or paint shall be applied to the internal threads.

Soldered joints

3.2.4.(1) In making a soldered joint the surface to be soldered shall be cleaned bright and the joint shall be properly fluxed, made with solder and thoroughly cleaned of all residue.

Flared joints

3.2.5.(1) In making a flared joint the pipe shall be expanded with a proper flaring tool.

(2) Flared joints shall not be used for hard (drawn) copper tube.

Hot-poured
joints

3.2.6.(1) Hot-poured joints shall be caulked tightly with twisted oakum and rammed, and a hot-poured caulking compound shall be placed to a depth of at least 25 mm all around the pipe.

(2) Hot-poured joints shall not be used except for vitrified clay or concrete pipe, or between either of such pipes and ferrous pipe.

Cement joints

3.2.7.(1) Cement joints in pipe that has a *size* of 6 in. or less shall be made by completely filling the annular space between the bell and the spigot with cement mortar.

(2) Every cement joint in pipe that has a *size* of more than 6 in. shall be made by

- (a) ramming a gasket of closely twisted hemp or oakum at least equal in length to the circumference of the pipe into the annular space between the bell and the spigot, and
- (b) filling the remaining annular space with mortar.

(3) The exterior of every cement joint shall be carefully shaped from the outside of the bell to the barrel of the pipe at an angle of approximately 45°.

(4) After every joint is made the interior of the pipe shall be thoroughly swabbed and cleaned.

(5) Cement joints shall not be used except for vitrified clay or concrete pipe or between either of such pipes and ferrous pipe.

3.2.8.(1) In making a burned lead joint the lead shall be lapped and fused to form a weld that is at least 1½ times as thick as the wall of the pipe.

Burned lead joints

- (2) In lead pipe the width of the weld shall be at least
 - (a) 13 mm where the *size* of the pipe is less than 3 in. ,
 - (b) 16 mm where the *size* of the pipe is 3 in. , or
 - (c) 19 mm where the *size* of the pipe is 4 in.

(3) In sheet lead the width of the weld shall be as specified in Table 3.2.A.

Table 3.2.A.
Forming Part of Sentence 3.2.8.(3)

| Weight of Sheet Lead, kg/m ² | Minimum Width of Weld, mm |
|--|------------------------------|
| 12.2 to 14.6 | 6 |
| 19.5 to 24.4 | 10 |
| 29.3 to 39.1 | 20 |
| 48.8 to 58.6 | 25 |
| 58.6 to 146.5 | 32 |
| Column 1 | 2 |

3.2.9. Mechanical joints shall be made with compounded elastomeric couplings or rings held by stainless steel or cast-iron clamps or contained within a compression connection or groove and shoulder type mechanical coupling.

Mechanical Joints

3.2.10.(1) Cold-caulked joints shall not be used except for bell and spigot pipe in a *water system* or a *drainage system*. The caulking compound shall be applied according to the manufacturer's directions.

Cold caulked joints

(2) Every cold-caulked joint in a *drainage system* shall be firmly packed with oakum and tightly caulked with cold caulking compound to a depth of at least 25 mm.

(3) Every cold-caulked joint in a *water system* shall be made by tightly caulking the entire depth of the socket with caulking compound.

SUBSECTION 3.3 JOINTS AND CONNECTIONS

3.3.1. Drilled and tapped joints shall not be made in a *soil-or-waste pipe* and *vent pipe* and fittings unless suitable provision has been made for drilling and tapping.

Drilled and tapped

3.3.2.(1) Cast-iron soil pipe and fittings shall not be welded.

Welded joints

(2) Galvanized steel pipe and fittings shall not be welded.

3.3.3.(1) Running thread and packing nut connections and unions with a gasket seal shall not be used downstream of a *trap weir* in a *drainage system* or in a *venting system*.

Unions and slip joints

- (2) A slip joint shall not be used
 - (a) in a *venting system*, or
 - (b) in a *drainage system*, except to connect a *fixture trap* to a *fixture drain* in an accessible location. (See A-2.3.1.(1) and (2) in Appendix A.)

3.3.4.

Increase or reducer

3.3.4. Every connection between 2 pipes of different *size* shall be made with an increaser or a reducer fitting installed so that it will permit the system to be completely drained.

Burned lead

3.3.5. Every joint in hard lead shall be made with a burned lead joint.

Dissimilar connections

3.3.6.(1) Adaptors, connectors or mechanical joints used to join dissimilar materials shall be designed to accommodate the required transition.

Connection of roof drain to leader

3.3.7. Every *roof drain* shall be securely connected to a *leader* and provision shall be made for expansion.

Connection of floor outlet fixtures

3.3.8.(1) Every pedestal urinal, floor-mounted water closet or *S-trap standard* shall be connected to a *fixture drain* by a floor flange, except that a cast-iron *trap standard* may be caulked to a cast-iron pipe.

(2) Except as provided in Sentence (3), every floor flange shall be of brass.

(3) Where cast iron or plastic pipe is used, a floor flange of the same material may be used.

(4) Every floor flange shall be securely set on a firm base and bolted to the *trap flange* of the *fixture*, and every joint shall be sealed with a natural rubber, synthetic rubber or asbestos graphite gasket, or with a closet setting compound.

(5) Where a lead water closet stub is used, the length of the stub below the floor flange shall be at least 75 mm.

3.3.9. The design and installation of every piping system shall, where necessary, include means to accommodate expansion and contraction of the piping system caused by temperature change or movement of the soil. (See Appendix A.)

3.3.10. Types M and DMV copper tube shall not be bent.

Making indirect connections

3.3.11.(1) Where a *fixture* or device is *indirectly connected*, the connection shall be made by terminating the *fixture drain* above the *flood level rim* or a *directly connected fixture* to form an *air break*.

(2) The size of the *air break* shall at least equal the *size* of the *fixture drain*, *branch* or pipe that terminates above the *directly connected fixture*, and it shall be at least 25 mm. (See Appendix A.)

SUBSECTION 3.4 SUPPORT OF PIPING

Capability of support

3.4.1.(1) Piping shall be provided with support that is capable of keeping the pipe in alignment and bearing the weight of the pipe and its contents.

(2) Every floor- or wall-mounted water-closet bowl shall be securely attached to the floor or wall by means of a flange and shall be stable.

(3) Every wall-mounted *fixture* shall be supported so that no strain is transmitted to the piping.

Independence of support

3.4.2. Piping, *fixtures*, tanks or devices shall be supported independently of each other.

Insulation of support

3.4.3. Where a hanger or support for copper tube or brass or copper pipe is of a material other than brass or copper, it shall be suitably separated and electrically insulated from the pipe.

Support for vertical piping

3.4.4.(1) Except as provided in Sentence (2), vertical piping shall be supported at its base and at the floor level of alternate *storeys* by metal rests, each of which can bear the weight of pipe that is between it and the metal rest above it.

(2) The maximum spacing of supports shall be 7.5 m.

3.4.5.(1) *Nominally horizontal* piping that is inside a *building* shall be braced to prevent swaying and buckling and to control the effects of thrust.

- (2) *Nominally horizontal* piping shall be supported so that
- (a) galvanized iron or steel pipe is supported at intervals not exceeding
 - (i) 3.75 m if the pipe *size* is 6 in. or more, and
 - (ii) 2.5 m if the pipe *size* is less than 6 in. .
 - (b) lead pipe is supported throughout its length.
 - (c) cast-iron pipe is supported
 - (i) at or adjacent to each hub or joint,
 - (ii) at intervals not exceeding 1.6 m, and
 - (iii) at intervals not exceeding 1 m if the pipe has mechanical joints and the length of pipe between adjacent fittings is 300 mm or less,
 - (d) asbestos-cement pipe is supported
 - (i) at intervals not exceeding 2 m or have 2 supports for every 4 m length of pipe, and
 - (ii) at intervals not exceeding 1 m where the length of pipe between adjacent fittings is 300 mm or less,
 - (e) ABS or PVC plastic pipe is supported
 - (i) at intervals not exceeding 1.2 m,
 - (ii) at the ends of *branches*,
 - (iii) at changes of direction or elevation, and
 - (iv) if the pipe is a *fixture drain* that is more than 1 m in length, as close as possible to the *trap*,
 - (f) CPVC or polybutylene plastic pipe is supported at intervals not exceeding 1 m, and
 - (g) copper tube and copper and brass pipe is supported at intervals not exceeding
 - (i) 3 m if the tube or pipe is hard temper and larger than 1 in. in *size*,
 - (ii) 2.5 m if the tube or pipe is hard temper and 1 in. in *size* or less, and
 - (iii) 2.5 m if the tube is soft temper.

(3) Where PVC, CPVC or ABS plastic pipe is installed

- (a) the pipe shall be aligned without added strain on the piping.
- (b) the pipe shall not be bent or pulled into position after being welded, and
- (c) hangers shall not compress, cut or abrade the pipe.

(4) Where hangers are used to support *nominally horizontal* piping they shall be

- (a) metal rods of at least 9.5 mm diam for pipe over 4 in. in *size*, and
- (b) solid or perforated metal strap hangers for pipe 4 in. or less in *size*.

(5) Where a hanger is attached to concrete or masonry, it shall be fastened by metal or expansion-type plugs that are inserted or built into the concrete or masonry.

3.4.6.(1) Except as provided in Sentence (2), *nominally horizontal* piping that is underground shall be supported on a base that is firm and continuous under the whole of the pipe. (See Appendix A.)

(2) *Nominally horizontal* piping installed underground that is not supported as described in Sentence (1) may be installed using hangers fixed to a foundation or structural slab provided that the hangers are capable of keeping the pipe in

3.4.6.

alignment and supporting the weight of the pipe, its contents and the fill over the pipe.

Support of vent pipe above roof

3.4.7. Where a *vent pipe* terminates above the surface of a roof it shall be supported or braced to prevent misalignment.
(See Article 5.6.5. for location of vent pipe terminals.)

SUBSECTION 3.5 PROTECTION OF PIPING

Backfill

3.5.1. Where piping is installed underground, the backfill shall be carefully placed and tamped to a height of 300 mm over the top of the pipe and shall be free of stones, boulders, cinders and frozen earth. (See Appendix A.)

Protection of non-metallic pipes

3.5.2. Where asbestos-cement drainage pipe or vitrified clay is located less than 600 mm below a basement floor and the floor is constructed of other than 75 mm or more of concrete, the pipe shall be protected by a 75 mm layer of concrete installed above the pipe. (See Appendix A.)

Isolation from loads

3.5.3. Where piping passes through or under a wall it shall be installed so that the wall does not bear on the pipe.

Protection from frost

3.5.4. Where piping may be exposed to freezing conditions it shall be protected from frost.

3.5.5. Plumbing, piping and equipment exposed to mechanical damage shall be protected.

SUBSECTION 3.6 TESTING OF DRAINAGE AND VENTING SYSTEMS

3.6.1.(1) Except in the case of an external *leader*, after a section of a *drainage system* or a *venting system* has been roughed in, and before any *fixture* is installed or piping is covered, a water or an air test shall be conducted.

(2) After every *fixture* is installed and before any part of the *drainage system* or *venting system* is placed in operation, a final test shall be carried out when requested.

(3) Where a prefabricated system is assembled off the *building* site in such a manner that it cannot be inspected and tested on site, off-site inspections and tests shall be conducted.

(4) Where a prefabricated system is installed as part of a *drainage and venting system*, all other plumbing work shall be tested and inspected and a final test shall be carried out on the complete system when requested.

(5) When requested, a ball test shall be made to any pipe in a *drainage system*.

Tests of drainage system

3.6.2.(1) Every pipe in a *drainage system*, except an external *leader* or *fixture outlet pipe*, shall be capable of withstanding without leakage a water test, air test and final test.

(2) Every pipe in a *drainage system* shall be capable of meeting a ball test.

Tests of venting system

3.6.3. Every *venting system* shall be capable of withstanding without leakage a water test, air test and final test.

3.6.4.(1) Where a water test is made it shall be applied to

- (a) the system as a whole, or
- (b) sections of the system, each of which is at least 3 m high and includes at least 1.5 m of the section below.

- (2) In making a water test
- (a) every opening except the highest shall be tightly closed with a testing plug or a screw cap, and
 - (b) the system or the section shall be kept filled with water for 15 min.
- 3.6.5.(1)** Where an air test is made Air test
- (a) every opening in the system shall be closed,
 - (b) air shall be forced into the system until a pressure of 35 kPa is created, and
 - (c) this pressure shall be maintained for 15 min without the addition of more air.
- 3.6.6.(1)** Where a final test is made Final test
- (a) every *trap* shall be filled with water,
 - (b) the bottom of the system being tested shall terminate at a *building trap*, test plug or cap,
 - (c) except as provided in Sentence (2), smoke from smoke-generating machines shall be forced into the system,
 - (d) when the smoke appears from all roof terminals they shall be closed, and
 - (e) a pressure equivalent to a 25 mm water column shall be maintained for 15 min without the addition of more smoke.
- (2) The smoke referred to in Clauses 3.6.6.(1)(c) and (d) may be omitted provided the roof terminals are closed and the system is subjected to an air pressure equivalent to a 25 mm water column maintained for 15 min without the addition of more air.
- 3.6.7.(1)** Where a ball test is made, a hard ball dense enough not to float shall be rolled through the pipe. Ball test
- (2) The diameter of the ball shall be not less than
 - (a) 50 mm where the *size* of the pipe is 3 in. or more, or
 - (b) 25 mm where the *size* of the pipe is less than 3 in.

SUBSECTION 3.7 TESTING OF POTABLE WATER SYSTEMS

- 3.7.1.(1)** After a section of a *potable water system* has been completed, and before it is placed in operation, a water test shall be conducted, except that an air test may be used in freezing conditions. Application of tests
- (2) A test may be applied to each section of the system or to the system as a whole.
- (3) Where a prefabricated system is assembled off the *building* site in such a manner that it cannot be inspected and tested on site, off-site inspections and tests shall be conducted.
- (4) Where a prefabricated system is installed as part of a *water system*, all other plumbing work shall be tested and inspected, and the complete system shall be pressure tested when requested.
- 3.7.2.(1)** Every *potable water system* shall be capable of Tests of water systems
- (a) withstanding without leakage a water pressure that is at least equal to the maximum pressure to which it may be subject in service, or
 - (b) withstanding for at least 2 h without a drop in pressure an air pressure that is at least 700 kPa.
- 3.7.3.(1)** Where a water test is made all air shall be expelled from the system before *fixture* control valves or faucets are closed. Water tests
- (2) *Potable water* shall be used to test a *potable water system*.

SECTION 4 DRAINAGE SYSTEMS

SUBSECTION 4.1 APPLICATION

4.1.1. This Section applies to *sanitary drainage systems, storm drainage systems, combined building drains or combined building sewers.*

SUBSECTION 4.2 CONNECTIONS TO DRAINAGE SYSTEMS

4.2.1.(1) Every *fixture* shall be *directly connected* to a *sanitary drainage system*, except that

- (a) drinking fountains may be
 - (i) *indirectly connected* to a *sanitary drainage system*, or
 - (ii) connected to a *storm drainage system* provided that where the system is subject to *backflow*, a *check valve* is installed in the fountain waste pipe,

(see Appendix A)

- (b) a floor drain may be connected to a *storm drainage system* provided it is located where it can receive only *clear-water waste* or *storm water*,
- (c) *fixtures* or appliances that discharge only *clear-water waste* may be connected to a *storm drainage system* or be drained onto a roof,
- (d) the following devices shall be *indirectly connected* to a *drainage system*:
 - (i) a device for the display, storage, preparation or processing of food or drink,
 - (ii) a sterilizer,
 - (iii) a device that uses water as a cooling or heating medium,
 - (iv) a water operated device,
 - (v) a water treatment device, or
 - (vi) a drain or overflow from a *water system* or a heating system.

(see Appendix A)

- (e) *fixtures* that have a hydraulic load of not more than $1\frac{1}{2}$ *fixture units* may be connected to a vertical section of a *circuit vent* provided
 - (i) the *fixtures* are located in the same *storey* as the *fixtures* served by the *vent pipes*,
 - (ii) not more than 2 *fixtures* are connected to the *vent pipe*,
 - (iii) where 2 *fixtures* are connected to the *vent pipe*, the connection is by means of a double sanitary T fitting, and
 - (iv) the section of the *vent pipe* that becomes a *wet vent* conforms to the requirements for *wet vents*,

(see Appendix A)

- (f) *fixtures* that have a hydraulic load of not more than $1\frac{1}{2}$ *fixture units* may be connected to the vertical section of a *yoke vent* provided
 - (i) not more than 2 *fixtures* are connected to the *vent pipe*,
 - (ii) where 2 *fixtures* are connected to the *vent pipe*, the connection is by means of a double sanitary T fitting, and
 - (iii) the section of the *vent pipe* that becomes a *wet vent* conforms to the requirements for *wet vents*, and

(see Appendix A)

- (g) *fixtures* may be connected to a *vent stack* provided
 - (i) the total hydraulic load of the connected *fixtures* does not exceed 8 *fixture units*,

- (ii) at least 1 *fixture* is connected to a vertical portion of the *vent stack* and upstream of any other *fixtures*,
- (iii) no other *fixture* is connected downstream of a water closet,
- (iv) all *fixtures* are located in the lowest *storey* served by the *vent stack*, and
- (v) the section of the *vent pipe* that becomes a *wet vent* conforms to the requirements for *wet vents*,

(see Appendix A).

(2) The connection of a *soil-or-waste pipe* to a *nominally horizontal soil-or-waste pipe* or to a *nominally horizontal offset* in a *soil-or-waste stack* shall be respectively at least 1.5 m measured horizontally from the bottom of a *soil-or-waste stack* or from the bottom of the upper vertical section of the *soil-or-waste stack* that

- (a) receives a discharge of 30 or more *fixture units*, or
- (b) receives a discharge from *fixtures* located on 2 or more *storeys*,

(see Appendix A).

(3) No other *fixture* shall be connected to a lead bend or stub that serves a water closet.

4.2.2. An overflow from a rainwater tank shall not be *directly connected* to a *drainage system*.

4.2.3.(1) Two or more *fixture outlet pipes* that serve outlets from a single *fixture* that is listed in Clause 4.2.1.(1)(d) may be *directly connected* to a *branch* that

- (a) has a size of at least 1¼ in., and
- (b) is terminated above the *flood level rim* of a *directly connected fixture* to form an *air break*.

(2) *Fixture drains* from *fixtures* that are listed in Subclauses (i) and (ii) of Clause 4.2.1.(1)(d) may be *directly connected* to a pipe that

- (a) is terminated to form an *air break* above the *flood level rim* of a *fixture* that is *directly connected* to a *sanitary drainage system*, and
- (b) is extended through the roof when *fixtures* that are on 3 or more *storeys* are connected to it. (See A-4.2.1.(1)(a) and (d) in Appendix A.)

(3) *Fixture drains* from *fixtures* that are listed in Subclauses (iii) to (vi) of Clause 4.2.1.(1)(d) may be *directly connected* to a pipe that

- (a) is terminated to form an *air break* above the *flood level rim* of a *fixture* that is *directly connected* to a *storm drainage system*, and
- (b) is extended through the roof when *fixtures* that are on 3 or more *storeys* are connected to it.

SUBSECTION 4.3 LOCATION OF FIXTURES

4.3.1. Urinals shall not be installed adjacent to wall and floor surfaces that are pervious to water.

Urinals

4.3.2. Indirect connections or any *trap* that may overflow shall not be located in a crawl space or any other unfrequented area.

Restricted locations

4.3.3. Garbage grinders, potato peelers and other similar types of equipment shall not be located upstream of an *interceptor*.

Garbage grinders

4.3.4. A floor drain or other *fixture* located in an oil transformer vault, a high voltage room or any room where flammable, dangerous or toxic chemicals are stored or handled shall not be connected to a *drainage system*.

4.4.1.

SUBSECTION 4.4 TREATMENT OF SEWAGE AND WASTES

| | |
|---------------------------------|--|
| Sewage treatment | 4.4.1. Where a <i>fixture</i> or equipment discharges <i>sewage</i> or waste that may damage or impair the <i>sanitary drainage system</i> or the functioning of a public or <i>private sewage disposal system</i> , provision shall be made for treatment of the <i>sewage</i> or waste before it is discharged to the <i>sanitary drainage system</i> . |
| Cooling of hot wastes or sewage | 4.4.2. Where a <i>fixture</i> discharges <i>sewage</i> or <i>clear-water waste</i> that is at a temperature in excess of 75°C, provision shall be made for cooling of the waste to 75°C or less before it is discharged to the <i>drainage system</i> . |
| Grease interceptors | 4.4.3.(1) Where a <i>fixture</i> discharging <i>sewage</i> that includes grease is located in a public kitchen or restaurant or in an institution, a grease <i>interceptor</i> shall be installed when required. (See Appendix A.) |
| Oil or gasoline interceptors | (2) Where the discharge from a <i>fixture</i> may contain oil or gasoline, an oil <i>interceptor</i> shall be installed. |
| Grit interceptors | (3) Where a <i>fixture</i> discharges sand, grit or similar materials, an <i>interceptor</i> designed for the purpose of trapping such discharges shall be installed. |
| Capacity of interceptors | (4) Every <i>interceptor</i> shall have sufficient capacity to perform the service for which it is provided. (See Article 5.5.2. for venting requirements for oil interceptors.) |

SUBSECTION 4.5 TRAPS

4.5.1.(1) Except as provided in Sentences (2), (3), (4) and (5) and in Article 4.5.2., every *fixture* shall be protected by a separate *trap*.

- (2) One *trap* may protect
 - (a) all the trays or compartments of a 2 or 3 compartment sink,
 - (b) a 2 compartment laundry tray, or
 - (c) 2 similar type single compartment *fixtures* located in the same room.(See Appendix A.)
- (3) One *trap* may serve a group of floor drains or shower drains, a group of washing machines or a group of laboratory sinks if the *fixtures*
 - (a) are in the same room, and
 - (b) are not located where they can receive food or other organic matter.(See Appendix A.)
- (4) An *indirectly connected fixture* that can discharge only *clear-water waste* other than a drinking fountain need not be protected by a *trap*.
(See Clause 4.2.1.(1)(d) for indirect connections.)
- (5) An *interceptor* with an effective water seal of at least 38 mm may serve as a *trap*. (See Appendix A.)

| | |
|---------------------------------|--|
| Traps for storm drainage system | 4.5.2.(1) Where a <i>storm drainage system</i> is connected to a <i>combined building sewer</i> or a public <i>combined sewer</i> , a <i>trap</i> shall be installed between any opening in the system and the drain or sewer, except that no <i>trap</i> is required if the opening is the upper end of a <i>leader</i> that terminates <ul style="list-style-type: none">(a) at a roof that is used only for weather protection, and(b) at least 900 mm above or at least 3.5 m in any other direction from any air inlet, openable window or door, and at least 1.8 m from a property line. (See Appendix A.) |
|---------------------------------|--|

(2) A floor drain which drains to a *storm drainage system* shall be protected by a *trap* which

- (a) is located between the floor drain and a *leader, storm building drain* or *storm building sewer*,
- (b) may serve all floor drains located in the same room,
- (c) need not be protected by a *vent pipe*, and
- (d) need not be provided with a *trap seal* primer.

4.5.3. Where a *subsoil drainage pipe* is connected to a *sanitary drainage system*, the connection shall be made on the upstream side of a *trap* with a *cleanout* or a trapped sump. (See Appendix A.)

4.5.4.(1) Where a *building trap* is installed it shall

- (a) be provided with a *cleanout* fitting on the upstream side of and directly over the *trap*,
- (b) be located upstream of the *building cleanout*,
- (c) be located
 - (i) inside the *building* as close as practical to the place where the *building drain* leaves the *building*, or
 - (ii) outside the *building* in a manhole.

Location and cleanout for building traps

(See Appendix A.)

4.5.5. Provision shall be made for maintaining the trap seal of a floor drain by the use of trap seal primer, by using the drain as a receptacle for an *indirectly connected* drinking fountain or by equally effective means. (See Appendix A.)

Trap seals

SUBSECTION 4.6 ARRANGEMENT OF DRAINAGE PIPING

4.6.1.(1) No vertical *soil-or-waste pipe* shall conduct both *sewage* and *storm water*.

Separate systems

(2) A *combined building drain* shall not be installed. (See Appendix A.)

Combined building drains

(3) There shall be no unused open ends in a *drainage system* and *dead ends* shall be so graded that water will not collect in them.

4.6.2.(1) A *soil-or-waste pipe* shall not be located directly above

- (a) non-pressure *potable* water storage tanks,
- (b) manholes in pressure *potable* water storage tanks, or
- (c) food-handling or processing equipment.

Location of piping

4.6.3.(1) Piping that is too low to drain into a *building sewer* by gravity shall be drained to a sump or receiving tank.

Sumps or tanks

(2) Where the sump or tank receives *sewage* it shall be water- and air-tight and shall be vented.

(3) Equipment such as a pump or ejector that can lift the contents of the sump or tank and discharge it into the *building drain* or *building sewer* shall be installed.

(4) Where the equipment does not operate automatically the *size* of the sump shall be sufficient to hold at least a 24 h accumulation of liquid.

(5) Where there is a *building trap* the discharge pipe from the equipment shall be connected to the *building drain* downstream of the *trap*.

(6) The discharge pipe from every *sewage* sump shall be equipped with a union, a *check valve* and a shut-off valve installed in that sequence in the direction of discharge.

(7) The discharge piping from a pump or ejector shall be sized for optimum flow velocities at pump design conditions.

(See Appendix A.)

4.6.4.

4.6.4.(1) A *backwater valve* or a gate valve shall not be installed in a *building drain* or in a *building sewer*. (See Appendix A.)

Protection from backflow

(2) Except as provided in Sentences (3), (4) and (5), where a *building drain* or a *branch* may be subject to *backflow*, a gate valve or a *backwater valve* shall be installed on every *fixture drain* connected to them when the *fixture* is located below the level of the adjoining street.

(3) Where the *fixture* is a floor drain, a removable screw cap may be installed on the upstream side of the *trap*.

(4) Where more than 1 *fixture* is located on a *storey* and all are connected to the same *branch*, the gate valve or *backwater valve* may be installed on the *branch*.

(5) A *subsoil drainage pipe* that drains into a *sanitary drainage system* that is subject to surcharge shall be connected in such a manner that *sewage* cannot back up into the *subsoil drainage pipe*. (See Appendix A.)

Mobile home sewer service

4.6.5.(1) A *building sewer* intended to serve a mobile home shall

- (a) be not less than 4 in. in *size*,
- (b) be terminated above ground,
- (c) be provided with
 - (i) a tamperproof terminal connection that is capable of being repeatedly connected, disconnected and sealed,
 - (ii) a protective concrete pad, and
 - (iii) a means to protect it from frost heave, and
- (d) be designed and constructed in accordance with good engineering practice.

SUBSECTION 4.7 CLEANOUTS

Cleanouts for sanitary drainage systems

4.7.1.(1) Every *sanitary drainage system* and *storm drainage system* shall be provided with *cleanouts* that will permit cleaning of the entire system. (See Appendix A.)

(2) A *cleanout* fitting shall be provided on the upstream side and directly over every running *trap*.

(3) Every interior *leader* shall be provided with a *cleanout* fitting at the bottom of the *leader* or not more than 3 m upstream from the bottom of the *leader*.

(4) Where a *cleanout* is required on a *building sewer* 8 in. or larger in *size*, it shall be a manhole.

(5) A *building sewer* shall not change direction or slope between the *building* and public sewer or between *cleanouts*, except that pipes not more than 6 in. in *size* may change direction

- (a) by not more than 5° every 3 m, or
- (b) by the use of fittings with a cumulative change in direction of not more than 45°.

(6) Every *building drain* shall be provided with a *cleanout* fitting that is located as close as practical to the place where the *building drain* leaves the *building*.

(7) Every *soil-or-waste stack* shall be provided with a *cleanout* fitting

- (a) at the bottom of the stack,
- (b) not more than 3 m upstream of the bottom of the stack, or
- (c) on a Y fitting connecting the stack to the *building drain* or *branch*.

(8) A *cleanout* shall be provided to permit the cleaning of the piping downstream of an *interceptor*.

(9) *Cleanouts* shall be installed so that the cumulative change in direction is not more than 90° between *cleanouts* in a drip pipe from a food receptacle or in a *fixture drain* serving a kitchen sink. (See Appendix A.)

4.7.2.(1) Except as provided in Sentences (2) and (3), the *size* and spacing of *cleanouts* in *nominally horizontal* pipes of a *drainage system* shall conform to Table 4.7.A.

Size and spacing of cleanouts

Table 4.7.A.

Forming part of Sentence 4.7.2.(1)

| Size of Drainage Pipe, in. | Minimum Size of Cleanout, in. | Maximum Spacing, m | |
|----------------------------|-------------------------------|--------------------|-----------------|
| | | One Way Rodding | Two Way Rodding |
| 2½ or less | Same size as drainage pipe | 7.5 | 15 |
| 3 and 4 | 3 | 15 | 30 |
| over 4 | 4 | 26 | 52 |
| Column 1 | 2 | 3 | 4 |

(2) The spacing between manholes serving a *building sewer*

- (a) 24 in. or less in *size* shall not exceed 90 m, and
- (b) over 24 in. in *size* shall not exceed 150 m.

(3) The *developed length* of a *building sewer* between the *building* and the first manhole to which the *building sewer* connects shall not exceed 75 m.

(4) Where a *building sewer* connects to another *building sewer* other than by a manhole, the *developed length* between the *building* and the *building sewer* to which it connects shall not exceed 30 m.

(5) *Cleanouts* capable of rodding in 1 direction only shall be installed to rod in the direction of flow.

4.7.3.(1) A manhole including the cover shall be designed to support all loads imposed upon it.

Manholes

(2) A manhole shall be provided with

- (a) a cover which shall provide an airtight seal if located within a *building*,
- (b) a rigid ladder of a corrosion-resistant material where the depth exceeds 1 m, and
- (c) a vent to the exterior if the manhole is located within a *building*.

(3) A manhole shall have a minimum horizontal dimension of 1.0 m, except that the top 1.5 m may be tapered from 1.0 m down to a minimum of 600 mm at the top.

(4) A manhole in a *sanitary drainage system* shall be channeled to direct the flow of effluent.

4.7.4.(1) *Cleanouts* and access covers shall be located so that the openings are readily accessible for rodding and cleaning purposes.

Location of cleanouts

(2) A *cleanout* shall not be located in a floor assembly in a manner that may constitute a hazard and shall not be used as a floor drain.

4.7.4.

(3) There shall be no change of direction between a *cleanout* fitting and the *trap* that it serves.

(4) The piping between a *cleanout* fitting and the drainage piping or vent piping that it serves shall not change direction by more than 45°.

SUBSECTION 4.8 MINIMUM SLOPE AND LENGTH OF DRAINAGE PIPES

Minimum slope **4.8.1.** Except as provided in Articles 4.10.8. and 4.10.9., every drainage pipe that has a *size* of 3 in. or less, and every *fixture drain* shall have a downward slope in the direction of flow of at least 1 in 50. (See Appendix A.)

Length of fixture outlet pipes **4.8.2.** Except for *fixture outlet pipes* installed in conformance with Sentence 4.5.1.(3), the *developed length* of every *fixture outlet pipe* shall not exceed 900 mm. (See A-4.5.1.(2) in Appendix A.)

SUBSECTION 4.9 SIZE OF DRAINAGE PIPES

No reduction in size **4.9.1.(1)** A *soil-or-waste pipe* shall be of a *size* not less than the *size* of
 (a) a *vent pipe* that is connected to it, or
 (b) the largest *soil-or-waste pipe* that drains into it.

Serving water closets **4.9.2.(1)** The *size* of every drainage pipe that serves a water closet shall be at least 3 in.

(2) The *size* of every *branch* or *building drain* downstream of the third water closet *fixture drain* connection shall be at least 4 in. when it has 3 or more water closet *fixture drains* directly connected to it.

(3) The *size* of every *soil-or-waste stack* that serves more than 6 water closets shall be at least 4 in.

4.9.3.(1) Except as provided in Sentences (2) and (3), the *size* of every *fixture outlet pipe* shall conform to Table 4.9.A.

(2) The part of the *fixture outlet pipe* that is common to 3 compartments of a sink shall be 1 *size* larger than the largest *fixture outlet pipe* of the compartments that it serves. (See Appendix A.)

Table 4.9.A.
 Forming Part of Sentences 4.9.3.(1) and 4.10.2.(1)

| <i>Fixture</i> | Min. <i>Size of Fixture Outlet Pipe, in.</i> | Hydraulic Load, <i>fixture units</i> |
|----------------------------------|--|--------------------------------------|
| Autopsy table | 1½ | 2 |
| Bathroom group | | |
| (a) with flush tank | | 6 |
| (b) with direct flush valve | | 8 |
| Bathtub (with or without shower) | 1½ | 1½ |
| Bath: foot, sitz or slab | 1½ | 1½ |
| Beer cabinet | 1½ | 1½ |
| Bidet | 1¼ | 1 |
| Column 1 | 2 | 3 |

Table 4.9.A. (Cont'd)
Forming Part of Sentences 4.9.3.(1) and 4.10.2.(1)

| <i>Fixture</i> | <i>Min. Size of Fixture Outlet Pipe, in.</i> | <i>Hydraulic Load, fixture units</i> |
|---|--|--|
| Clothes washer | | |
| (a) domestic | NA | 1½ with 1½ <i>trap</i> |
| (b) commercial | NA | 2 with 1½ <i>trap</i> |
| Dental unit or cuspidor | 1¼ | 1 |
| Dishwasher | | |
| (a) domestic type | 1½ | 1½ { no load when connected to garbage grinder or domestic sink |
| (b) commercial type | 2 | |
| Drinking fountain | 1¼ | ½ |
| Floor drain | 2 | 2 with 2 in. <i>trap</i> 3 with 3 in. <i>trap</i> |
| Garbage grinder, commercial type | 2 | 3 |
| Icebox | 1¼ | 1 |
| Laundry tray | | |
| (a) single or double units or 2 single units with common <i>trap</i> | 1½ | 1½ |
| (b) 3 compartments | 1½ | 2 |
| Lavatory | | |
| (a) barber or beauty parlor | 1½ | 1½ |
| (b) dental | 1¼ | 1 |
| (c) domestic type, single or 2 single with common <i>trap</i> | 1¼ | 1 with 1¼ in. <i>trap</i> 1½ with 1½ in. <i>trap</i> |
| (d) multiple or industrial type | 1½ | according to Table 4.10.A. |
| Potato peeler | 2 | 3 |
| Shower drain | | |
| (a) from 1 head | 1½ | 1½ |
| (b) from 2 or 3 heads | 2 | 3 |
| (c) from 4 to 6 heads | 3 | 6 |
| Sink | | |
| (a) domestic and other small types with or without garbage grinders, single, double or 2 single with a common <i>trap</i> | 1½ | 1½ |
| (b) Other sinks | 1½ | 1½ with 1½ in. <i>trap</i> 2 with 2 in. <i>trap</i> 3 with 3 in. <i>trap</i> |
| Urinal | | |
| (a) pedestal, siphon-jet or blowout type | 2 | 4 |
| (b) stall, washout type | 2 | 2 |
| (c) wall | | |
| (i) washout type | 1½ | 1½ |
| (ii) other types | 2 | 3 |
| Water closet | | |
| (a) with flush tank | 3 | 4 |
| (b) with direct flush valve | 3 | 6 |
| Column 1 | 2 | 3 |

4.10.1.

SUBSECTION 4.10 HYDRAULIC LOADS

(See Appendix A for determination of hydraulic loads and drainage pipe sizes.)

Total loads

- 4.10.1.(1)** The hydraulic load on a pipe is the total load from
- (a) every *fixture* that is connected to the system upstream of the pipe,
 - (b) every *fixture* for which provision is made for future connection upstream of the pipe, and
 - (c) all roofs and paved surfaces that drain into the system upstream of the pipe.

Hydraulic loads from fixtures

4.10.2.(1) The hydraulic load from a *fixture* that is listed in Table 4.9.A. is the number of *fixture units* set forth in the Table.

Hydraulic loads from fixtures not in Table 4.9.A.

(2) Except as provided in Sentence (1), the hydraulic load from a *fixture* that is not listed in Table 4.9.A. is the number of *fixture units* set forth in Table 4.10.A. for the *trap* of the *size* that serves the *fixture*.

Table 4.10.A.
Forming Part of Sentence 4.10.2.(2)

| Size of Trap, in. | Hydraulic Load, <i>fixture units</i> |
|-------------------|--------------------------------------|
| 1¼ | 1 |
| 1½ | 2 |
| 2 | 3 |
| 2½ | 4 |
| 3 | 5 |
| 4 | 6 |
| Column 1 | 2 |

Hydraulic loads from fixtures with continuous flows

4.10.3.(1) Except as provided in Sentence (2), the hydraulic load from a *fixture* that produces a continuous or semi-continuous flow, such as a pump or an air-conditioning *fixture*, is 26.4 *fixture units* for each litre per second of flow.

(2) Where a *fixture* or equipment that produces a continuous or semi-continuous flow drains to a *combined sewer* or to a *storm sewer*, the hydraulic load from the *fixture* is 900 L for each litre per second of flow.

Hydraulic loads from roofs or paved surfaces

4.10.4.(1) Except as provided in Sentence (2), the hydraulic load in litres from a roof or paved surface is the maximum 15 min rainfall determined in conformance with Subsection 2.2.1. of Part 2 of the National Building Code of Canada 1985, multiplied by the sum of

- (a) the area in square metres of the horizontal projection of the surface that is drained, and
- (b) one-half the area in square metres of the largest adjoining vertical surface.

(See Appendix A.)

(2) *Flow control roof drains* may be installed provided

- (a) the maximum drain down time does not exceed 24 h,
- (b) the roof structure has been designed to carry the load of the stored water,
- (c) one or more scuppers are installed so that the maximum depth of water on the roof cannot exceed 150 mm,
- (d) they are located not more than 15 m from the edge of the roof and not more than 30 m from adjacent drains, and
- (e) there is at least 1 drain for each 900 m².

Conversion of fixture units to litres

4.10.5.(1) Except as provided in Sentence 4.10.3.(2), where the hydraulic load is to be expressed in litres, *fixture units* shall be converted as follows:

- (a) when the number of *fixture units* is 260 or fewer, the load is 2 360 L, and
- (b) when the number of *fixture units* exceeds 260, the load is 9.1 L for each *fixture unit*.

4.10.6.(1) Except as provided in Sentence (2), the hydraulic load that is drained to every *soil-or-waste stack* shall conform to Table 4.10.B.

(2) Where the *nominally horizontal offset* in a *soil-or-waste stack* is 1.5 m or more, the hydraulic load that is served by it shall conform to Table 4.10.C. or Table 4.10.D., whichever is the less restrictive.

Table 4.10.B.
Forming Part of Sentence 4.10.6.(1)

| Size of Stack, in. | Maximum Load on <i>Soil-or-Waste Stack</i> , <i>fixture units</i> | | |
|--------------------|--|--|--|
| | Maximum Load on Stack that Passes through 3 <i>Storeys</i> or Less | Maximum Load on Stack that Passes through more than 3 <i>Storeys</i> | Maximum Load to be Drained to Stack of more than 3 <i>Storeys</i> from any 1 <i>Storey</i> |
| 1¼ | 2 | 2 | 2 |
| 1½ | 5 | 8 | 2 |
| 2 | 10 | 24 | 6 |
| 2½ | 20 | 42 | 9 |
| 3 | 60 | 60 | 16 |
| 4 | 240 | 500 | 90 |
| 5 | 540 | 1,100 | 200 |
| 6 | 960 | 1,900 | 350 |
| 8 | 2,200 | 3,600 | 600 |
| 10 | 3,800 | 5,600 | 1,000 |
| 12 | 6,000 | 8,400 | 1,500 |
| Column 1 | 2 | 3 | 4 |

4.10.7. The hydraulic load that is drained to a *branch* shall conform to Table 4.10.C.

Hydraulic loads on branches

Table 4.10.C.
Forming Part of Article 4.10.7. and Sentence 4.10.6.(2)

| Size of <i>Branch</i> , in. | Maximum Load on <i>Branch</i> , <i>fixture units</i> |
|-----------------------------|--|
| 1¼ | 2 |
| 1½ | 3 |
| 2 | 6 |
| 2½ | 12 |
| 3 | 27 |
| 4 | 180 |
| 5 | 390 |
| 6 | 700 |
| 8 | 1,600 |
| 10 | 2,500 |
| 12 | 3,900 |
| Column 1 | 2 |

4.10.8.

Hydraulic loads on sanitary building drains or sewers

4.10.8. The hydraulic load that is drained to a *sanitary building drain* or a *sanitary building sewer* shall conform to Table 4.10.D.

Table 4.10.D.
Forming Part of Article 4.10.8. and Sentence 4.10.6.(2)

| Size of Drain or Sewer, in. | Maximum Load on Drain or Sewer, <i>fixture units</i> | | | | | |
|-----------------------------|--|----------|----------|----------|---------|---------|
| | Slope | | | | | |
| | 1 in 400 | 1 in 200 | 1 in 133 | 1 in 100 | 1 in 50 | 1 in 25 |
| 3 | — | — | — | — | 27 | 36 |
| 4 | — | — | — | 180 | 240 | 300 |
| 5 | — | — | 380 | 390 | 480 | 670 |
| 6 | — | — | 600 | 700 | 840 | 1,300 |
| 8 | — | 1,400 | 1,500 | 1,600 | 2,250 | 3,370 |
| 10 | — | 2,500 | 2,700 | 3,000 | 4,500 | 6,500 |
| 12 | 2,240 | 3,900 | 4,500 | 5,400 | 8,300 | 13,000 |
| 15 | 4,800 | 7,000 | 9,300 | 10,400 | 16,300 | 22,500 |
| Column 1 | 2 | 3 | 4 | 5 | 6 | 7 |

Hydraulic loads on storm or combined building drains or sewers

4.10.9. The hydraulic load that is drained to a *storm building drain*, a *storm building sewer* or a *combined building sewer* shall conform to Table 4.10.E.

Table 4.10.E.
Forming Part of Article 4.10.9.

| Size of Drain or Sewer, in. | Maximum Load on Drain or Sewer, L | | | | | | |
|-----------------------------|-----------------------------------|----------|----------|----------|---------|---------|---------|
| | Slope | | | | | | |
| | 1 in 400 | 1 in 200 | 1 in 133 | 1 in 100 | 1 in 68 | 1 in 50 | 1 in 25 |
| 3 | — | — | — | — | 2 390 | 2 770 | 3 910 |
| 4 | — | — | — | 4 220 | 5 160 | 5 970 | 8 430 |
| 5 | — | — | 6 760 | 7 650 | 9 350 | 10 800 | 15 300 |
| 6 | — | — | 10 700 | 12 400 | 15 200 | 17 600 | 24 900 |
| 8 | — | 18 900 | 23 200 | 26 700 | 32 800 | 37 800 | 53 600 |
| 10 | — | 34 300 | 41 900 | 48 500 | 59 400 | 68 600 | 97 000 |
| 12 | 37 400 | 55 900 | 68 300 | 78 700 | 96 500 | 112 000 | 158 000 |
| 15 | 71 400 | 101 000 | 124 000 | 143 000 | 175 000 | 202 000 | 287 000 |
| Column 1 | 2 | 3 | 4 | 5 | 6 | 7 | 8 |

4.10.10 The hydraulic load that is drained to a *roof gutter* shall conform to Table 4.10.F.

Table 4.10.F.
Forming Part of Article 4.10.10.

| Size of Gutter, in. | Area of Gutter, cm ² | Maximum Load on Gutter, L | | | |
|---------------------|---------------------------------|---------------------------|----------|---------|---------|
| | | Slope of Gutter | | | |
| | | 1 in 200 | 1 in 100 | 1 in 50 | 1 in 25 |
| 3 | 22.8 | 406 | 559 | 812 | 1 140 |
| 4 | 40.5 | 838 | 1 190 | 1 700 | 2 410 |
| 5 | 63.3 | 1 470 | 2 080 | 2 950 | 4 170 |
| 6 | 91.2 | 2 260 | 3 200 | 4 520 | 6 530 |
| 7 | 124.1 | 3 250 | 4 600 | 6 500 | 9 190 |
| 8 | 162.1 | 4 700 | 6 600 | 9 400 | 13 200 |
| 10 | 253.4 | 8 480 | 12 000 | 17 000 | 23 600 |
| Column 1 | 2 | 3 | 4 | 5 | 6 |

4.10.11. The hydraulic load that is drained to a *leader* shall conform to Table 4.10.G.

Hydraulic loads on leaders

Table 4.10.G.
Forming Part of Article 4.10.11.

| Circular <i>Leader</i> | | Non-Circular <i>Leader</i> | |
|-----------------------------|--------------|---|--------------|
| Size of <i>Leader</i> , in. | Max. Load, L | Area of <i>Leader</i> , cm ² | Max. Load, L |
| 2 | 1 700 | 20.3 | 1 520 |
| 2½ | 3 070 | 31.6 | 2 770 |
| 3 | 5 000 | 45.6 | 4 500 |
| 4 | 10 800 | 81.1 | 9 700 |
| 5 | 19 500 | 126.6 | 17 600 |
| 6 | 31 800 | 182.4 | 28 700 |
| 8 | 68 300 | 324.3 | 61 500 |
| Column 1 | 2 | 3 | 4 |

SECTION 5 VENTING SYSTEMS

SUBSECTION 5.1 VENT PIPES FOR TRAPS

5.1.1.(1) Except as provided in Sentences (2) and (3), a *trap* shall be protected by a *vent pipe*.

Venting for traps

- (2) A *trap* that serves a floor drain need not be protected where
 - (a) the *size* of the *trap* is at least 3 in.,
 - (b) the length of the *fixture drain* is at least 450 mm, and
 - (c) the fall on the *fixture drain* does not exceed its *size*.

Exceptions for floor drains

(See Appendix A.)

- (3) A *trap* need not be protected by a *vent pipe* where it serves
 - (a) a *subsoil drainage pipe*,
 - (b) a *storm drainage system*, or
 - (c) where it forms part of an indirect *drainage system*.

Exceptions

(See Appendix A.)

SUBSECTION 5.2 SINGLE STOREY WET VENTING

5.2.1.(1) A *soil-or-waste pipe* that is extended as a *stack vent* or a *continuous vent* may serve as a *single storey wet vent* provided that

Single storey wet venting

- (a) all *fixtures* served by the *wet vent* are in the same *storey*,
- (b) the number of wet vented *fixtures* does not exceed 4,
- (c) the number of wet vented water closets does not exceed 2,
- (d) when 2 water closets are installed they are connected at the same level by means of a double fitting,
- (e) where the water closet *trap arm* is connected to a vertical pipe, it shall be connected downstream of all other *fixtures*, and
- (f) the *fixture drains* are connected separately and directly into the *soil-or-waste pipe*.

(See Appendix A.)

5.2.2.(1) A section of a *branch* or *building drain* may serve as a *single storey wet vent* provided that

Circuit venting

- (a) a *circuit vent* is connected to it,
- (b) all *fixtures* served by the *circuit vent* are located in the same *storey*, and
- (c) no *soil-or-waste stack* is connected to it upstream of a wet vented *fixture*.

(See Appendix A.)

5.2.2.

(2) A *relief vent* shall be connected to the *branch or building drain* that forms part of a circuit vented system

- (a) downstream of the connection for the circuit vented *fixture* that is farthest downstream when the *soil-or-waste pipe* to which the wet vented system is connected receives a hydraulic load of more than 6 *fixture units* upstream of that connection,
- (b) so that the cumulative horizontal change in direction in the *branch or building drain* between *vent pipes* does not exceed 45°, and
- (c) so that there are not more than 8 wet vented *fixtures* connected to the *branch or building drain* between *vent pipe* connections.

(See Appendix A.)

(3) A *soil-or-waste pipe* that is extended as a *continuous vent* may serve as a *relief vent* provided the *soil-or-waste pipe* is sized as a *wet vent* in conformance with Articles 5.7.3. and 5.8.1. (See Appendix A.)

(4) A *relief vent* may serve as a combined *relief vent* for 2 or more *circuit vented branches* providing that there are not more than 8 wet vented *fixtures* connected between the combined *relief vent* and the *circuit vents*. (See Appendix A.)

SUBSECTION 5.3 MULTI-STOREY WET VENTING

5.3.1.(1) A *soil-or-waste stack* may serve as a multi-storey *wet vent* provided that

- (a) *trap arms* connected to the stack do not exceed 2 in. in *size* except as provided in Sentence (2),
- (b) *trap arms* are separately and *directly connected* to the *soil-or-waste stack*,
- (c) when the *soil-or-waste stack* extends through more than 2 *storeys*, the total discharge from any 1 *storey* above the second *storey* does not exceed 4 *fixture units*,
- (d) there is not more than 1 *nominally horizontal offset* in the *soil-or-waste stack* and the *offset*
 - (i) does not exceed 1.2 m for pipe *sizes* 2 in. or less,
 - (ii) does not exceed 2.5 m for pipe *sizes* larger than 2 in., and
 - (iii) is at least 150 mm above the *flood level rim* of any *fixture* that drains to the *soil-or-waste stack* below the *offset*,
- (e) no *soil-or-waste pipe* connects to an *offset*, and
- (f) the wet vented portion of the *soil-or-waste stack* is the same *size* from its base to the highest *fixture* connection.

(2) Water closets shall be connected below all other *fixtures*.

(3) Where 2 water closets are installed they shall be connected by a double fitting.

SUBSECTION 5.4 VENT PIPES FOR SOIL-OR-WASTE STACKS

Stack vents 5.4.1.(1) The upper end of every *soil-or-waste stack* shall terminate in a *stack vent*.

Stack venting (2) A *stack vent* may serve as the *vent pipe* for 1 or 2 *fixtures* connecting at the same level.
(See Appendix A.)

Vent stacks 5.4.2.(1) A *vent stack* shall be installed to protect the base of every *soil-or-waste stack*, other than a *soil-or-waste stack* that serves as a multi-storey *wet vent*, that has *fixtures* draining to it on more than 4 *storeys*.

(2) The *vent stack* shall be connected to the *soil-or-waste stack* at or below the lowest *soil-or-waste pipe* connection, or at the junction of the *soil-or-waste stack* with a *branch* or *building drain*.

(See Appendix A.)

5.4.3.(1) Except as provided in Sentence (4), where a *soil-or-waste stack* receives the discharge from *fixtures* located on more than 11 *storeys* a *yoke vent* shall be installed

Yoke vents

- (a) for each section of 5 *storeys* or part thereof on which *fixtures* are located other than the top and bottom 5 *storeys*, and
- (b) at or immediately above each *offset* or double *offset*.

(2) The *yoke vent* shall be connected to the *soil-or-waste stack* by means of a drainage fitting at or immediately below the lowest *soil-or-waste pipe* from the lowest *storey* of the section described in Sentence (1).

(3) The *yoke vent* shall be connected to the *vent stack* at least 1 m above the floor level of the lowest *storey* in the section described in Sentence (1).

(4) A required *yoke vent* need not be installed provided the *soil-or-waste stack* is interconnected to the *vent stack* in each *storey* of the section in which *fixtures* are located by means of a vent equal in size to the *branch* or *fixture drain* or 2 in., whichever is smaller.

5.4.4. A *soil-or-waste stack* that has a *nominally horizontal offset* more than 1.5 m long and above which the upper vertical portion of the stack passes through more than 2 *storeys* and receives a hydraulic load of more than 100 *fixture units* shall be vented by a *relief vent* either

Relief vents

- (a) connected to the vertical section immediately above the *offset*,
- (b) connected to the lower vertical section at or above the highest *soil-or-waste pipe* connection, or
- (c) extended as a vertical continuation of the lower section.

(See Appendix A.)

SUBSECTION 5.5 MISCELLANEOUS VENT PIPES

5.5.1. Every sump that receives *sewage* shall be provided with a *vent pipe* that is connected to the top of the sump.

Venting of sewage sumps

5.5.2.(1) Every oil *interceptor* shall be provided with 2 *vent pipes* that

- (a) connect to the *interceptor* at opposite ends,
- (b) extend independently to open air, and
- (c) terminate at elevations differing by at least 300 mm.

Venting of oil interceptors

(2) Adjacent compartments within every oil *interceptor* shall be connected to each other by a vent opening.

5.5.3. Where a *building trap* is installed, a *fresh air inlet* not less than 4 in. in size shall be connected upstream and within 1.2 m of the *building trap* and downstream of any other connection. (See A-4.5.4.(1) in Appendix A.)

Fresh air inlets

5.5.4. Where provision is made for a *fixture* to be installed in the future, the *drainage system* and *venting system* shall be sized accordingly and provision made for the necessary future connections.

SUBSECTION 5.6 ARRANGEMENT OF VENT PIPES

5.6.1. Every *vent pipe* shall be installed without depressions in which moisture can collect.

Drainage of vent pipes

5.6.2.

Vent pipe connections

5.6.2.(1) Every *vent pipe* shall be connected as directly as possible from its lower end to outside air, and where it is practicable to do so, the pipe shall be installed in a *nominally vertical* position.

(2) Except for *wet vents*, where a *vent pipe* is connected to a *nominally horizontal soil-or-waste pipe*, the connection shall be above the horizontal centre line of the *soil-or-waste pipe*. (See Appendix A.)

Location of vent pipes

5.6.3.(1) Except as provided in Sentences (2) and (3), a *vent pipe* that protects a *fixture trap* shall be located so that

- (a) the *developed length* of the *trap arm* is
 - (i) not less than twice the *size* of the *fixture drain*, and
 - (ii) not more than 1.5 m,
- (b) the total fall of the *trap arm* is not greater than the *size* of the *fixture drain*, and
- (c) the *trap arm* does not have a cumulative change of direction of more than 135°.

(See Appendix A.)

(2) The *trap arm* of water closets, *S-trap standards* or *fixtures* that depend on siphonic action for the proper functioning of the *fixture* that discharges vertically shall not have a cumulative change of direction of more than 225°. (See Appendix A.)

(3) A *vent pipe* that protects a water closet or a *fixture* that depends on siphonic action for its proper functioning shall be so located that the distance between connections of the *fixture drain* to the *fixture* and the *vent pipe* shall not exceed

- (a) 1 m in the vertical plane, and
- (b) 3 m in the horizontal plane.

(See Appendix A.)

Vents to connect above fixtures they serve

5.6.4.(1) An *individual vent*, *dual vent*, *continuous vent*, *circuit vent* or *relief vent* shall extend above the *flood level rim* of every *fixture* that it serves before being connected to another *vent pipe*.

(2) No *vent pipe* shall be connected to a *branch vent* or a *vent stack* in such a manner that a blockage in a *soil-or-waste pipe* would cause waste to drain through the *vent pipe* to the *drainage system*.

Terminals

5.6.5.(1) The upper end of every *vent pipe* that is not terminated in open air shall be connected to a *venting system* that is terminated in open air.

(2) The upper end of every *vent pipe* that is terminated in open air, other than a *vent pipe* that serves an *oil interceptor* or a *fresh air inlet*, shall be extended through a roof.

(3) Except for a *fresh air inlet*, where a *vent pipe* is terminated in open air the terminal shall be located

- (a) at least 1 m above or at least 3.5 m in any other direction from every air inlet, openable window or door,
- (b) at least 2 m above or at least 3.5 m in any other direction from a roof that supports an *occupancy*,
- (c) at least 2 m above ground, and
- (d) at least 1.8 m from every property line.

(See Appendix A.)

(4) Where a *vent pipe* passes through a roof it shall

- (a) terminate high enough to prevent the entry of roof drainage but at least 25 mm above the roof, and

(b) be flashed to prevent the entry of water between the *vent pipe* and the roof. (See Article 2.9.11. for *vent pipe* flashings.)

(5) Where a *vent pipe* passes through a roof and may be subject to frost closure it shall be protected from frost closure

- (a) by keeping its height to a minimum,
- (b) by being increased at least 1 *size* immediately before penetrating the roof,
- (c) by being insulated, or
- (d) by being protected in some other manner.

SUBSECTION 5.7 MINIMUM SIZE OF VENT PIPES

5.7.1. The *size* of every *vent pipe* shall conform to Table 5.7.A.

General

Table 5.7.A.
Forming Part of Article 5.7.1.

| <i>Size of Trap Served, in.</i> | <i>Minimum Size of Vent Pipe, in.</i> |
|---------------------------------|---------------------------------------|
| 1¼ | 1¼ |
| 1½ | 1¼ |
| 2 | 1½ |
| 2½ | 1½ |
| 3 | 1½ |
| 4 | 1½ |
| 5 | 2 |
| 6 | 2 |
| Column 1 | 2 |

5.7.2. A *branch vent, stack vent, vent stack* or *header* shall be of a *size* not less than the *size* of a *vent pipe* that is connected to it.

5.7.3.(1) Except as provided in Article 5.7.1., the minimum *size* of a *relief vent* installed in conjunction with a *circuit vent* shall be 1 *size* smaller than the required *size* of the *circuit vent*.

Relief vents

(2) Except as provided in Article 5.7.1., the minimum *size* of a *relief vent* installed in conjunction with an *offset* in a *soil-or-waste stack* shall be 1 *size* smaller than the *stack vent*.

5.7.4. Except as provided in Article 5.7.1., the minimum *size* of a *yoke vent* shall be 1 *size* smaller than the *size* of the smaller pipe to which it is connected.

Yoke vents

5.7.5. The minimum *size* of a *vent pipe* that serves a manhole within a *building* shall be 2 in.

5.7.6.(1) Except as provided in Sentence (2), the minimum *size* of the *vent pipe* for a *sewage sump* shall be 1 *size* smaller than the *size* of the largest inlet pipe to the sump.

Sewage pump vents

(2) The minimum *size* of every *vent pipe* for a *sewage sump* shall be 2 in., but the *vent pipe* need not be larger than 4 in.

5.7.7. The minimum *size* of every *vent pipe* that serves an oil *interceptor* shall be 2 in.

Oil interceptors

SUBSECTION 5.8 SIZING OF VENT PIPES

(See Appendix A for an explanation of sizing of vent pipes.)

5.8.1.(1) The hydraulic load that drains to a single *storey wet vent* shall conform to Table 5.8.A. (See Appendix A.)

Table 5.8.A.
Forming Part of Article 5.8.1.

| Size of Wet Vent, in. | Maximum Hydraulic Load Connected to a Single Storey Wet Vent, fixture units |
|-----------------------|---|
| 1¼ | 1 |
| 1½ | 2 |
| 2 | 5 |
| 2½ | 8 |
| 3 | 27 |
| 4 | 120 |
| Column 1 | 2 |

(2) The hydraulic load that drains to a multi *storey wet vent* shall conform to Table 5.8.B. (See Appendix A.)

Table 5.8.B.
Forming Part of Sentence 5.8.1.(2)

| Size of Wet Vent Portion of Soil-or-Waste Stack, in. | Maximum Hydraulic Load, fixture units | | |
|--|---------------------------------------|-----------------------------------|---------------|
| | Not Serving Water Closets | Serving Water Closets | |
| | | Fixtures Other than Water Closets | Water Closets |
| 1½ | 2 | — | — |
| 2 | 4 | 3 | 8 |
| 2½ | 6 | 4 | 8 |
| 3 | 12 | 6 | 8 |
| 4 | 36 | 14 | 8 |
| 5 | NA | 18 | 8 |
| 6 | NA | 23 | 8 |
| Column 1 | 2 | 3 | 4 |

5.8.2.(1) A *circuit vent*, a *branch vent*, a *header* and a *continuous vent*, other than one that is an *individual vent* or a *dual vent*, shall be sized in conformance with Table 5.8.C.

(2) The length of a *continuous vent* for the purpose of Table 5.8.C. shall be its *developed length* from the vertical *soil-or-waste pipe* to a *vent stack*, *stack vent*, *header* or open air.

(3) The length of a *circuit vent* for the purpose of Table 5.8.C. shall be its *developed length* from the horizontal *soil-or-waste pipe* to a *vent stack*, *stack vent*, *header* or open air.

(4) The length of a *branch vent* for the purpose of Table 5.8.C. shall be the *developed length* of vent piping from the most distant *soil-or-waste pipe* connection to a *vent stack*, *stack vent*, *header* or open air.

(5) The length of a *header* for the purpose of Table 5.8.C. shall be the *developed length* of vent piping from the most distant *soil-or-waste pipe* connection to open air.

(See Appendix A.)

Table 5.8.C.
Forming Part of Sentence 5.8.2.(1)

| Maximum Load Served, <i>fixture units</i> | Size of <i>Vent Pipe</i> , in. | | | | | | | | | |
|---|--|------|---------------|------|-------|-------|-------|------|-------|--|
| | 1¼ | 1½ | 2 | 2½ | 3 | 4 | 5 | 6 | 8 | |
| | Maximum Length of <i>Vent Pipe</i> , m | | | | | | | | | |
| 2 | 9.0 | | | | | | | | | |
| 8 | 9.0 | 30.0 | | | | | | | | |
| 20 | 7.5 | 15.0 | 46.0 | | | | | | | |
| 40 | 4.5 | 9.0 | 30.0 | 91.0 | | | | | | |
| 60 | | 4.5 | 15.0 | 24.0 | 120.0 | | | | | |
| 100 | | | 9.0 | 21.0 | 55.0 | 215.0 | | | | |
| 1,100 | | | | 6.0 | 15.0 | 61.0 | 215.0 | | | |
| 1,900 | | | NOT PERMITTED | | | 6.0 | 21.0 | 61.0 | 215.0 | |
| 3,600 | | | | | | 7.5 | 18.0 | 76.0 | 245.0 | |
| 5,600 | | | | | | | 7.5 | 18.0 | 76.0 | |
| Column 1 | 2 | 3 | 4 | 5 | 6 | 7 | 8 | 9 | 10 | |

5.8.3.(1) A *stack vent* or *vent stack* shall be sized in accordance with Table 5.8.D.

Stack vents and vent stacks

(2) The length of a *stack vent* or a *vent stack* for the purpose of Table 5.8.D. shall be its *developed length* from its lower end to open air. (See Appendix A.)

Table 5.8.D.
Forming Part of Sentence 5.8.3.(1)

| Size of <i>Soil-or-Waste Stack</i> , in. | Total Hydraulic Load Served by <i>Vent</i> , <i>fixture units</i> | Size of <i>Stack Vent</i> or <i>Vent Stack</i> , in. | | | | | | | | |
|--|---|--|------|------|-------|-------|-------|-------|-------|----|
| | | 1¼ | 1½ | 2 | 2½ | 3 | 4 | 5 | 6 | 8 |
| | | Maximum Length of <i>Vent Pipe</i> , m | | | | | | | | |
| 1¼ | 0-2 | 9.0 | | | | | | | | |
| 1½ | 0-8 | 15.0 | 46.0 | | | | | | | |
| 2 | 0-8 | 9.0 | 23.0 | 61.0 | | | | | | |
| 2 | 9-20 | 7.5 | 15.0 | 46.0 | | | | | | |
| 2 | 21-24 | 4.5 | 9.0 | 30.0 | | | | | | |
| 2½ | 0-20 | | 14.0 | 46.0 | 120.0 | | | | | |
| 2½ | 21-42 | | 9.0 | 30.0 | 91.0 | | | | | |
| 3 | 0-10 | | 9.0 | 30.0 | 61.0 | 185.0 | | | | |
| 3 | 11-30 | | 4.5 | 18.0 | 61.0 | 150.0 | | | | |
| 3 | 31-60 | | 4.5 | 15.0 | 24.0 | 120.0 | | | | |
| 4 | 0-100 | | | 11.0 | 30.0 | 79.0 | 305.0 | | | |
| 4 | 101-200 | | | 9.0 | 27.0 | 76.0 | 275.0 | | | |
| 4 | 201-500 | | | 6.0 | 21.0 | 55.0 | 215.0 | | | |
| 5 | 0-200 | | | | 11.0 | 24.0 | 105.0 | 305.0 | | |
| 5 | 201-500 | | | | 9.0 | 21.0 | 91.0 | 275.0 | | |
| 5 | 501-1,100 | | | | 6.0 | 15.0 | 61.0 | 215.0 | | |
| 6 | 0-350 | | | | 7.5 | 15.0 | 61.0 | 120.0 | 395.0 | |
| Column 1 | 2 | 3 | 4 | 5 | 6 | 7 | 8 | 9 | 10 | 11 |

Table 5.8.D. (Cont'd)
Forming Part of Sentence 5.8.3.(1)

| Size of Soil-or-Waste Stack, in. | Total Hydraulic Load Served by Vent. fixture units | Size of Stack Vent or Vent Stack, in. | | | | | | | | | | |
|----------------------------------|--|---------------------------------------|----|---|-----|-----|------|------|-------|-------|-------|--|
| | | 1¼ | 1½ | 2 | 2½ | 3 | 4 | 5 | 6 | 8 | | |
| | | Maximum Length of Vent Pipe, m | | | | | | | | | | |
| 6 | 351-620 | | | | 4.5 | 9.0 | 38.0 | 91.0 | 335.0 | | | |
| 6 | 621-960 | | | | | 7.5 | 30.0 | 76.0 | 305.0 | | | |
| 6 | 961-1,900 | | | | | 6.0 | 21.0 | 61.0 | 215.0 | | | |
| 8 | 0-600 | | | | | | 15.0 | 46.0 | 150.0 | 395.0 | | |
| 8 | 601-1,400 | | | | | | 12.0 | 30.0 | 120.0 | 365.0 | | |
| 8 | 1,401-2,200 | NOT PERMITTED | | | | | | 9.0 | 27.0 | 105.0 | 335.0 | |
| 8 | 2,201-3,600 | NOT PERMITTED | | | | | | 7.5 | 18.0 | 76.0 | 245.0 | |
| 10 | 0-1,000 | | | | | | | 23.0 | 38.0 | 305.0 | | |
| 10 | 1,001-2,500 | | | | | | | 15.0 | 30.0 | 150.0 | | |
| 10 | 2,501-3,300 | | | | | | | 9.0 | 24.0 | 105.0 | | |
| 10 | 3,301-5,600 | | | | | | | 7.5 | 18.0 | 76.0 | | |
| Column 1 | 2 | 3 | 4 | 5 | 6 | 7 | 8 | 9 | 10 | 11 | | |

SECTION 6 POTABLE WATER SYSTEMS

SUBSECTION 6.1 ARRANGEMENT OF PIPING

6.1.1.(1) Potable water systems shall be designed, fabricated and installed in accordance with good engineering practice, such as described in the ASHRAE Guide and Data Books, the ASHRAE Handbooks and ASPE Data Books. (See Appendix A.)

Hot and cold faucets

(2) Every fixture supplied with separate hot and cold water controls shall have the hot water control on the left and the cold on the right.

Drainage of piping

6.1.2. A water distribution system shall be installed so that the system can be drained and, if it is not practicable to avoid a trap or sag in a pipe, provision shall be made to drain it.

Shut-off valve

6.1.3.(1) Every water service pipe shall be provided with a shut-off valve where the pipe enters the building.

(2) Every pipe that is supplied with water from a gravity water tank or a tank of a private water supply system shall be provided with a shut-off valve located close to the tank.

Valves on risers

6.1.4. Except for a single-family house, every riser shall be provided with a shut-off valve at the source of supply.

Shut-off valves for water closets

6.1.5. Every water closet shall be provided with a shut-off valve on its water supply pipe.

6.1.6. Except for a single-family house, shut-off valves shall be installed in every suite in a building of residential occupancy as defined in the National Building Code of Canada 1985 as may be necessary to ensure that when the supply to 1 suite is shut off the supply to the remainder of the building is not interrupted.

Shut-off valves for other buildings

6.1.7.(1) In buildings other than those described in Article 6.1.6., shut-off valves shall be provided on the water supply to

- (a) every *fixture* or device, or
- (b) group of *fixtures* or devices in the same room except as provided in Article 6.1.5.

6.1.8. Every pipe that supplies a hot water tank shall be provided with a shut-off valve located close to the tank.

6.1.9. Every pipe that passes through an exterior wall to supply water to the exterior of the *building* shall be provided with a frost-proof hydrant or a stop-and-waste cock located inside the *building* and close to the wall. Stop-and-waste cocks for exterior supply

6.1.10 A *check valve* shall be installed at the *building* end of a *water service pipe* where the pipe is made of plastic that is suitable for cold water use only. Check valves

6.1.11.(1) Every flushing device that serves a water closet or 1 or more urinals shall have sufficient capacity and be adjusted to deliver at each operation a volume of water that will thoroughly flush the *fixture* or *fixtures* that it serves.

(2) Where a manually operated flushing device is installed it shall serve only 1 *fixture*.

6.1.12.(1) In addition to the requirements in Sentence (2), every hot water tank of a *storage-type service water heater* shall be equipped with a pressure relief valve designed to open when the water pressure in the tank reaches the rated working pressure of the tank, and so located that the pressure in the tank shall not exceed the pressure at the relief valve by more than 35 kPa under any condition of flow within the distribution system. Pressure relief valves for storage type service water heaters

(2) Every hot water tank of a *storage-type service water heater* shall be equipped with Temperature relief valves

- (a) a temperature relief valve with a temperature sensing element located within the top 150 mm of the tank and designed to open and discharge sufficient water from the tank to keep the temperature of the water in the tank from exceeding 99°C under all operating conditions, or

- (b) a device that Temperature limit control
 - (i) is designed to shut off the supply of electricity or fuel to the heater,
 - (ii) is not connected to and operates independently of the thermostatic control that determines the temperature of the water in the tank, and
 - (iii) is located and maintained on or within the top 150 mm of the tank so that the maximum temperature of the water in the tank shall not exceed 99°C under all operating conditions.

(3) Every tank equipped as specified in Clause 6.1.12.(2)(b) shall bear the information in a clearly visible location that it is so equipped.

(4) A pressure relief valve and a temperature relief valve may be combined where Sentences (1) and (2) are complied with. Combination pressure and temperature relief valves

(5) Every *indirect service water heater* shall be equipped with Relief valves for indirect service water heaters

- (a) a pressure relief valve, and
- (b) a temperature relief valve on every storage tank that forms part of the system.

(6) Every pipe that conveys water from a temperature relief, pressure relief or a combined temperature and pressure relief valve which is installed on a hot water tank shall Relief valve pipe discharge

6.1.12.

- (a) have a *size* at least equal to the *size* of the outlet of the valve, and
- (b) terminate above a floor drain, sump, *fixture* or other safe location.

(7) The temperature relief valve required in Clause 6.1.12.(5)(b) shall have a temperature sensing element located within the top 150 mm of the tank and be designed to open and discharge sufficient water to keep the temperature of the water in the tank from exceeding 99°C under all operating conditions.

(8) No shut-off valve shall be installed on the pipe between any tank and the relief valves or on the discharge lines from such relief valves.

(9) A vacuum relief valve shall be installed when any tank may be subject to back-siphonage.

Water hammer

6.1.13. Provision shall be made to protect the *water distribution system* from the adverse effects of water hammer. (See Appendix A.)

Mobile home
water service

6.1.14.(1) A *water service pipe* intended to serve a mobile home shall

- (a) be not less than $\frac{3}{4}$ in. in *size*,
- (b) be terminated above ground, and
- (c) be provided with
 - (i) a tamperproof terminal connection that is capable of being repeatedly connected, disconnected and sealed,
 - (ii) a protective concrete pad,
 - (iii) a means to protect it from frost heave, and
 - (iv) a curb stop and a means of draining that part of the pipe located above the frost line when not in use.

SUBSECTION 6.2 PROTECTION FROM CONTAMINATION

Connection of
systems

6.2.1.(1) Except as provided in Sentence (2), connections to *potable water systems* shall be designed so that non-potable water, foreign matter, foreign chemicals or substances that may render the water non-potable cannot enter the system.

(2) A water treatment device or apparatus shall not be installed unless it can be demonstrated that the device or apparatus will not introduce material into the system that would endanger health.

(3) The use of an assembly of differential valves and *check valves* including an automatically opened spillage port to the atmosphere designed to prevent *backflow* is permitted in installations where it is desirable to zone or isolate a multiple of openings or connections.

(4) No *private water supply system* shall be interconnected with a public water supply system.

(5) No *potable water pipe* shall be connected to an ejector unless provided with a *vacuum breaker*.

(6) Aspirators shall not be *directly connected* to a *waste pipe* that is connected to a sewer, but may be *indirectly connected* to the inlet side of a *trap*, and shall be equipped with a *vacuum breaker* installed at least 150 mm above the aspirator unit.

(7) Except as provided in Sentence (6), no water operated equipment shall be installed in a *potable water supply system*.
(See Appendix A.)

Cleaning of
systems

6.2.2. A newly installed part of a *water system* shall be cleaned before the system is put into operation and, where required, shall be flushed and chlorinated.

6.2.3.(1) Except for a *fixture* in which the water surface may be exposed to a pressure greater than atmospheric, a water supply outlet shall be Air gap or back-siphonage preventer

- (a) located so as to provide an *air gap*, or
- (b) provided with a *back-siphonage preventer*.

(See Appendix A.)

(2) Every *air gap* shall be at least 25 mm in height, and Height of air gap

- (a) at least twice the diameter of the opening of the water supply outlet in height, or
- (b) of a design that will preclude the return of water to the *potable water system* when the water level in the *fixture* or device is at its maximum height and a negative pressure of 50 kPa exists in the water supply pipe.

(3) Tank type water closet valves shall be provided with a *back-siphonage preventer* in conformance with Sentence 2.9.9.(2).

6.2.4.(1) Where the *critical level* is not marked on a *back-siphonage preventer*, the *critical level* shall be taken as the lowest point on the *back-siphonage preventer*.

(2) Where a *back-siphonage preventer* is installed, it shall be located on the downstream side of the *fixture* control valve or faucet so that it will be subject to water supply pressure only when the valve or faucet is open. (See Appendix A explaining Sentence 6.2.3.(1).)

(3) A *back-siphonage preventer* shall be installed so that the *critical level* is at least 25 mm above the *flood level rim* of a *fixture* or maximum water level in a tank.

6.2.5. Where a water supply pipe is connected to a device which may be subjected to a pressure in excess of atmospheric, the pipe shall be protected by a *backflow preventer*. (See Appendix A explaining *backflow preventer*.) Protection of devices under pressure

6.2.6. Where a water supply serves both *potable* and fire protection systems, the fire protection system shall be designed to prevent backflow into the *potable* water supply.

SUBSECTION 6.3 SIZE AND CAPACITY OF PIPES

(See Appendix A.)

6.3.1. Every *water distribution system* shall be designed to provide peak demand flow when the flow pressures at the supply openings conform to Table 6.3.A. Design

6.3.2.(1) Except as provided in Sentence (3), the hydraulic load of a *fixture* or device that is listed in Table 6.3.A. shall be the number of *fixture units* given in the table. Hydraulic load

(2) Except as provided in Sentences (1) and (3), the hydraulic load of a *fixture* that is not listed in Table 6.3.A. is the number of *fixture units* listed in Table 6.3.B.

(3) Where *fixtures* are supplied with both hot and cold water, the hydraulic loads for maximum separate demands shall be 75 per cent of the hydraulic load of the *fixture units* given in Tables 6.3.A. and 6.3.B.

6.3.3. Where the static pressure may exceed 550 kPa, a pressure reducing valve shall be installed to limit the maximum static pressure to not more than 550 kPa in areas that may be occupied. Static pressure

6.3.4.(1) Every *water service pipe* shall be sized according to the peak demand flow but shall be not less than 3/4 in. Size

Table 6.3.A.
Forming Part of Subsection 6.3

| <i>Fixture or Device</i> | Minimum Size of Supply Pipe, in. | Min. Flow Pressure, ⁽¹⁾ kPa (gauge) | Hydraulic Load, <i>fixture units</i> | |
|--|---|--|---|----------------|
| | | | Private | Public |
| Bathroom group | | | | |
| (a) with flush tank | NA | NA | 6 | — |
| (b) with direct flush valve | NA | NA | 8 | — |
| Bathtub (with or without shower) | ½ | 50 | 2 | 4 |
| Clothes washer | ½ | 100 | 3 | — |
| Dishwasher, domestic | ½ | 100 | 3 | — |
| Drinking fountain | ¾ | 100 | ½ | 1 |
| Hose bib | ½ | 100 | ⁽²⁾ | ⁽²⁾ |
| Lavatory | ¾ | 50 | 1 | 2 |
| Sink | | | | |
| (a) kitchen, domestic | ½ | 50 | 2 | — |
| (b) kitchen, commercial | ¾ | 50 | — | 4 |
| (c) service | ½ | 50 | — | 3 |
| (d) service with direct flush valve | ¾ | 100 | — | 5 |
| Shower head | ½ | 50 | 2 | 4 |
| Urinal | | | | |
| (a) with flush tank | ½ | 50 | — | 3 |
| (b) with direct flush valve | ¾ | 100 | — | 5 |
| Water closet | | | | |
| (a) with flush tank | ¾ | 50 | 3 | 5 |
| (b) with direct flush valve | 1 | 100 | 6 | 10 |
| Column 1 | 2 | 3 | 4 | 5 |

Notes to Table 6.3.A.:

(1) Measured immediately upstream of faucet or supply valve.

(2) A continuous load of 0.38 L/s.

Table 6.3.B.
Forming Part of Sentence 6.3.2.(2)

| Size of Supply Pipe, in. | Hydraulic Load, <i>fixture units</i> | |
|-----------------------------|--------------------------------------|--------|
| | Private | Public |
| ¾ | 1 | 2 |
| ½ | 2 | 4 |
| ¾ | 3 | 6 |
| 1 | 6 | 10 |
| Column 1 | 2 | 3 |

(2) Except as provided in Sentence (3), the *size* of a pipe that supplies a *fixture* or device shall conform to Column 2 of Table 6.3.A.

(3) A tail piece or connector not more than 750 mm in length and not less than ¼ in. inside diameter may be used to supply water to a *fixture* or device.

SECTION 7 NON-POTABLE WATER SYSTEMS

SUBSECTION 7.1 CONNECTION

7.1.1. A *non-potable water system* shall not be connected to a *potable water system*.

SUBSECTION 7.2 IDENTIFICATION

7.2.1. *Non-potable water piping* shall be identified by markings that are permanent, distinct and easily recognized.

SUBSECTION 7.3 LOCATION

7.3.1. *Non-potable water piping* shall not be located

- (a) where food is prepared in a food processing plant,
- (b) above food-handling equipment,
- (c) above a non-pressurized *potable water tank*, or
- (d) above a cover of a pressurized *potable water tank*.

Location of pipe

7.3.2. An outlet from a *non-potable water system* shall not be located where it can discharge into

Location of outlets

- (a) a sink or lavatory,
- (b) a *fixture* into which an outlet from a *potable water system* is discharged, or
- (c) a *fixture* that is used for a purpose related to the preparation, handling or dispensing of food, drink or products that are intended for human consumption.

(See Appendix A.)

APPENDIX A

EXPLANATORY MATERIAL for the Canadian Plumbing Code 1985

The Appendix to this document is included for explanatory purposes only and does not form part of the requirements. The bold-face reference numbers that introduce each item apply to the requirements in the Code.

SYMBOLS AND ABBREVIATIONS

The following symbols and abbreviations have been used in the diagrams:

Water and drainage pipe _____ Subsoil drains _____

Vent pipe

| | | | |
|----|-------------------|-----|--------------|
| BG | Bathroom group | KS | Kitchen sink |
| BT | Bathtub | LAV | Lavatory |
| CO | Cleanout | LT | Laundry tray |
| DF | Drinking fountain | RD | Roof drain |
| FD | Floor drain | UR | Urinals |
| FS | Floor sink | WC | Water Closet |

A-1.3.2. National Building Code Definitions. An asterisk (*) following a defined word or term means that the definition for that word or term is taken from the National Building Code of Canada 1985.

A-1.3.2. Backflow Preventer

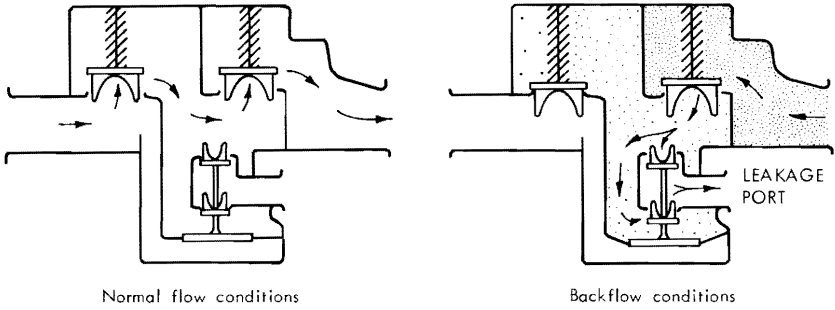

(a) Reduced pressure backflow preventer

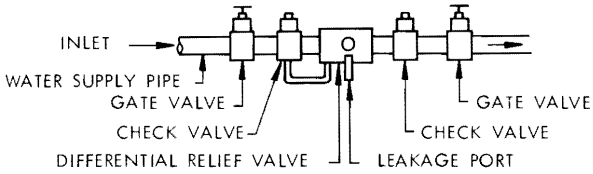

(b) Assembly of differential valves and check valves used as a backflow preventer

BR 5249-1

A-1.3.2.

A-1.3.2. Back-Siphonage

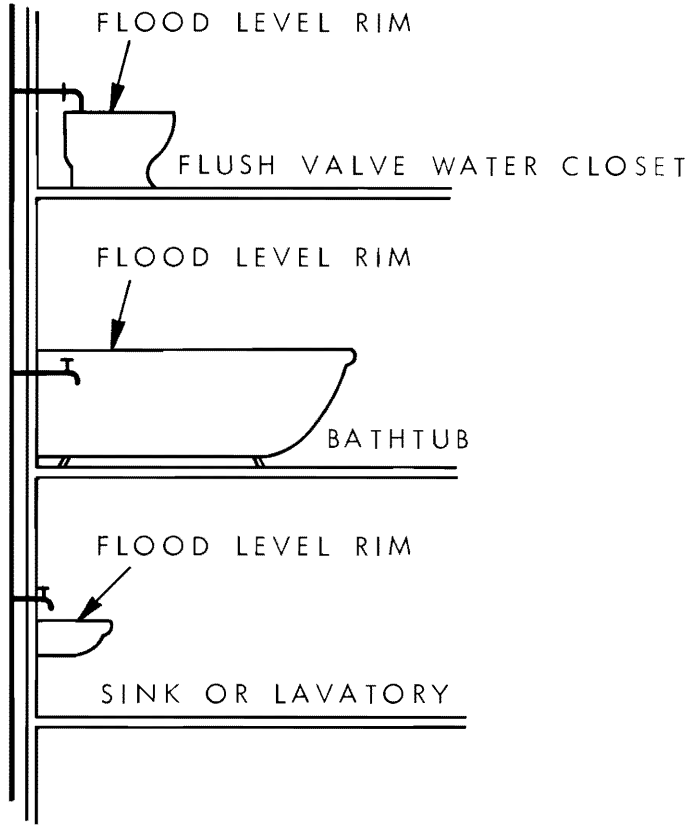

BR 5249-2

This diagram shows a situation that is fairly common in old buildings. If the bathtub is filled to a level above the faucet outlet, or if the flush valve of the water closet is faulty, and if the faucet at the sink or lavatory on the lower floor is opened, water can be drawn (siphoned) from the bathtub or the water closet into the water system when the pressure in the water system is low or the water supply has been shut off.

A-1.3.2. Back-Siphonage Preventer

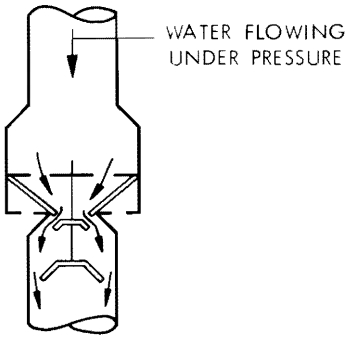

(a) Normal operation with valve open

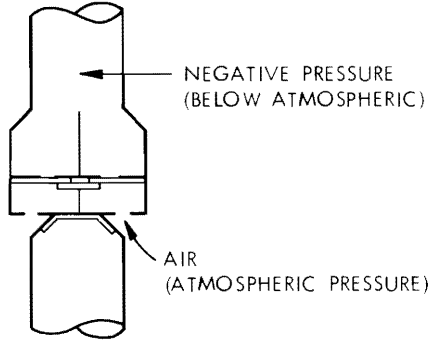

(b) No backflow - valve closed by atmospheric pressure

BR 5249-3

Back-siphonage can be prevented in the above situations by providing an air gap or a back-siphonage preventer (see Subsection 6.2 of this Code).

A-1.3.2. Branch Vent

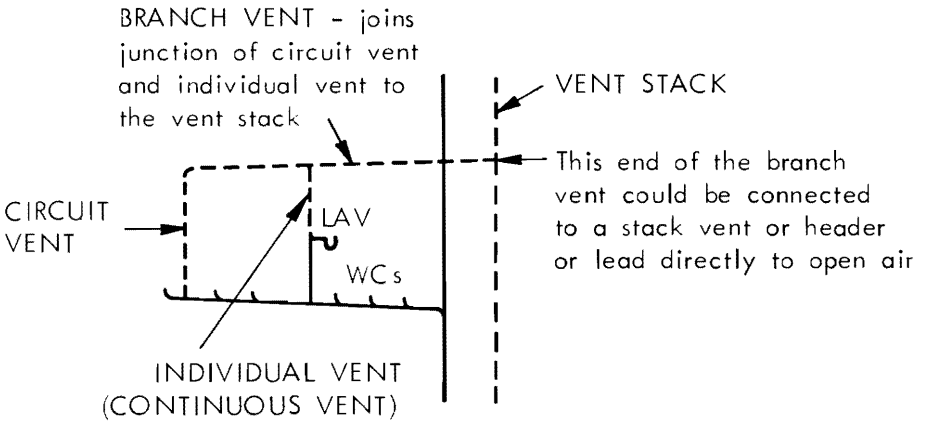

BR 5249-4

(See also explanation for definitions for header and drainage system.)

A-1.3.2.

A-1.3.2. Circuit Vent

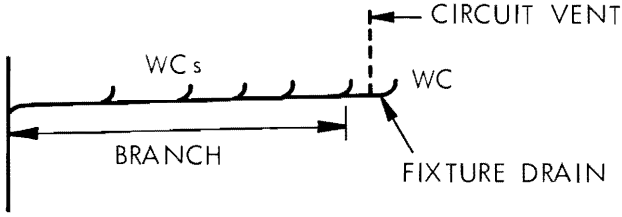

BR 5249-5

(See also explanation for definition for drainage system.)

A-1.3.2. Clear-Water Waste

Examples of clear-water waste are the waste waters discharged from a drinking fountain, cooling jacket, air conditioner or relief valve outlet.

A-1.3.2. Drainage System (Drainage and venting systems)

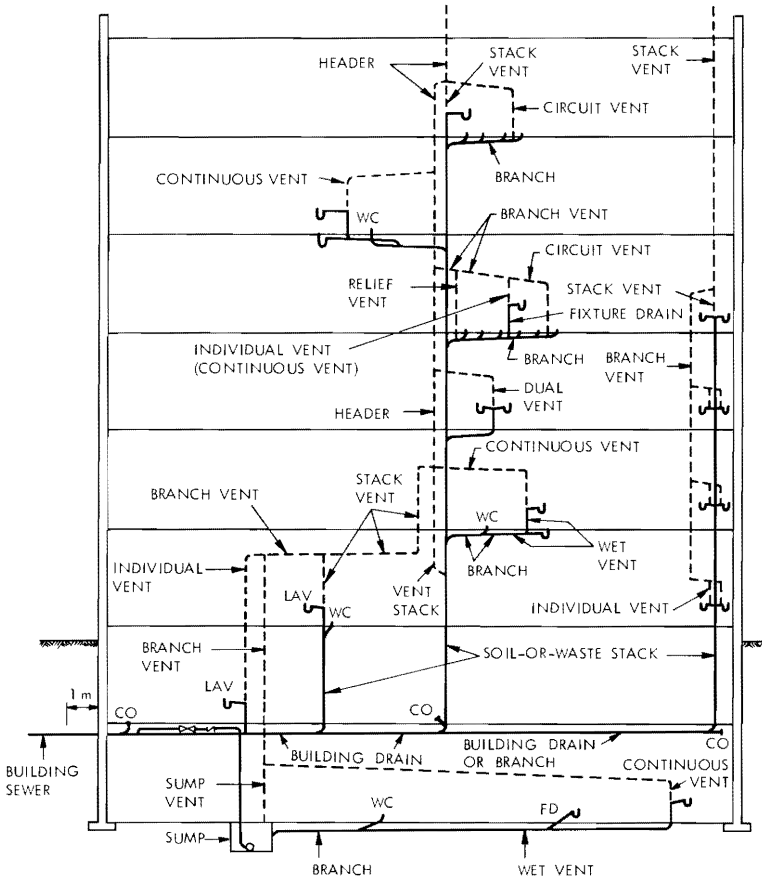

BR 5249-6

**A-1.3.2. Drainage System (Cont'd) (Partial drainage system.
Isometric view ignoring vents)**

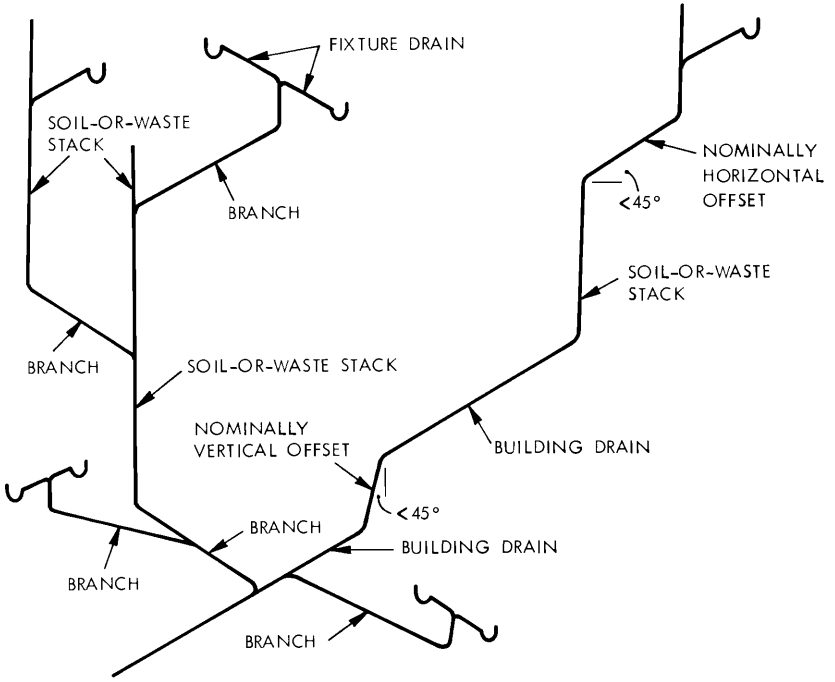

Partial Drainage System
(Isometric View)

BR 5249-7

A-1.3.2. Fixture Drain and Fixture Outlet Pipe

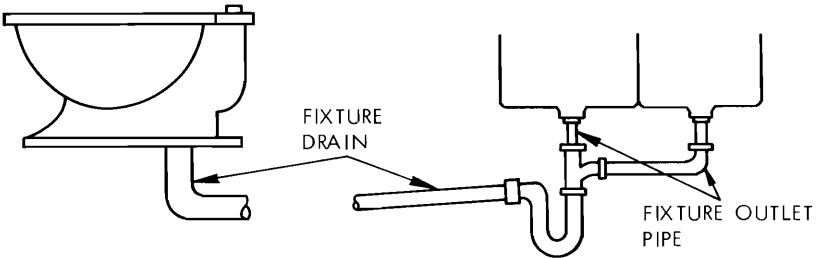

BR 5249-9

A1.3.2.

A-1.3.2. Header

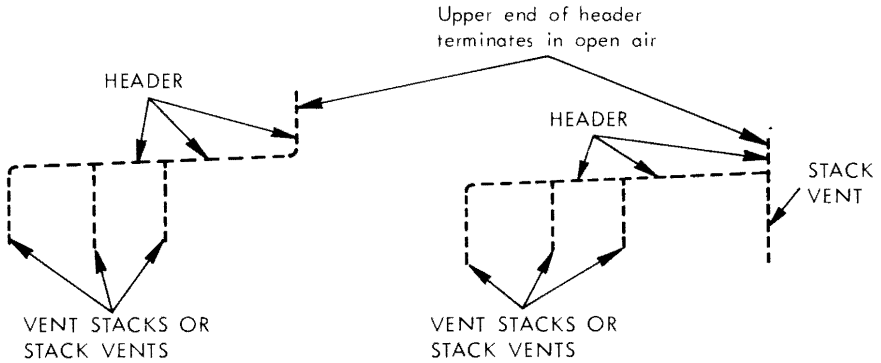

BR 5249-10

Although a header is similar to a branch vent, it serves the special purpose of connecting the tops of stack vents or vent stacks. To make certain that it is adequate for that purpose it is made larger than a branch vent. The developed length used to determine its size is the total length from the most distant soil-or-waste pipe to open air, rather than the shorter length used to size a branch vent.

A-1.3.2. Nominally Horizontal and Nominally Vertical

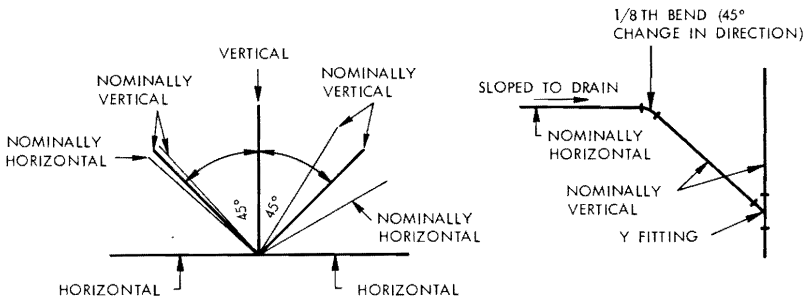

BR 5249-11

A-1.3.2. Offset

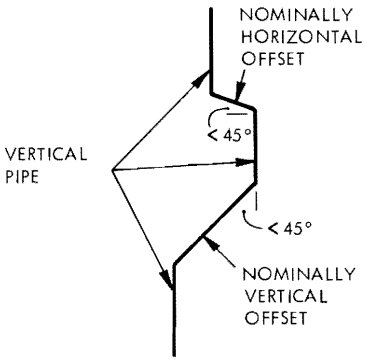

(a) Elevation view of vertical pipe



(b) Plan view of horizontal pipe

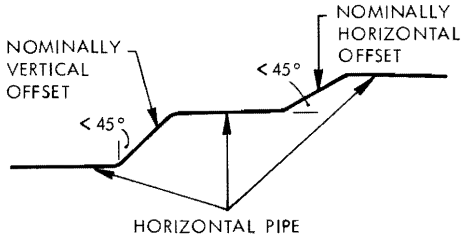

(c) Elevation view of horizontal pipe

BR 5249-12

A-1.3.2. Plumbing System

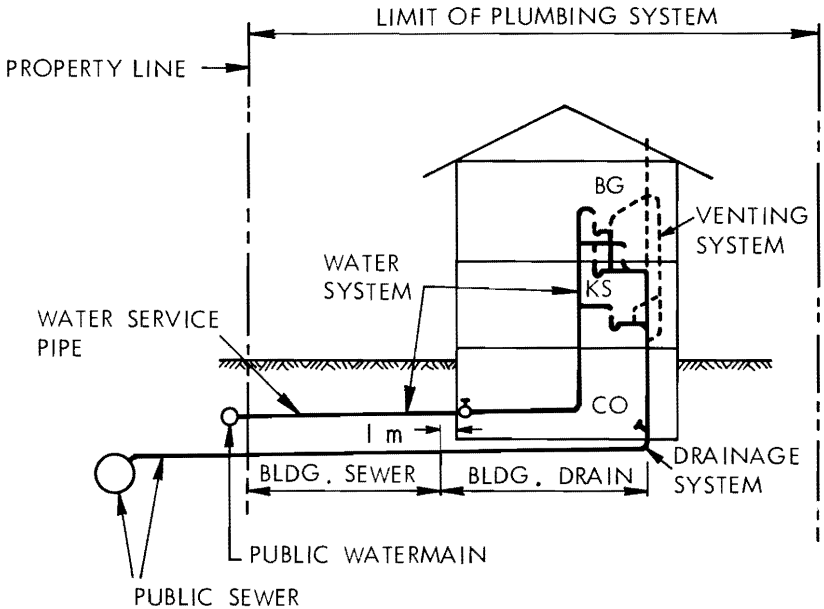

BR 5249-13

A-1.6.1.

A-1.6.1.(2) Combined Building Drains. Combined building drains may have proved to be acceptable on the basis of past performance in some localities and their acceptance under Article 1.4.3. of this Code may be warranted.

A-1.6.4. Service Piping

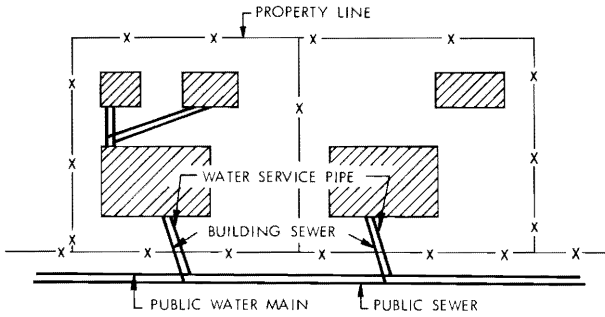

(a) Permitted

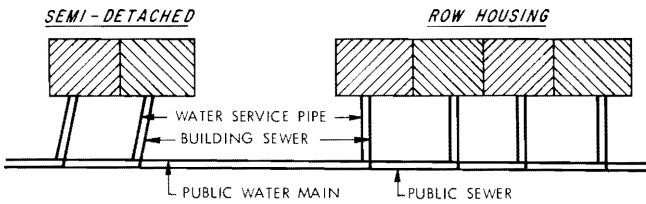

(b) Permitted

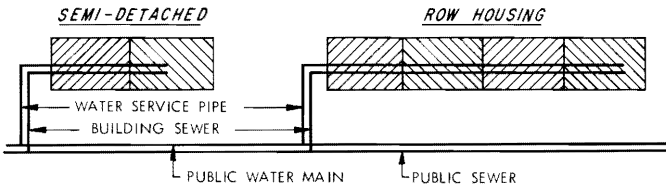

(c) Permitted

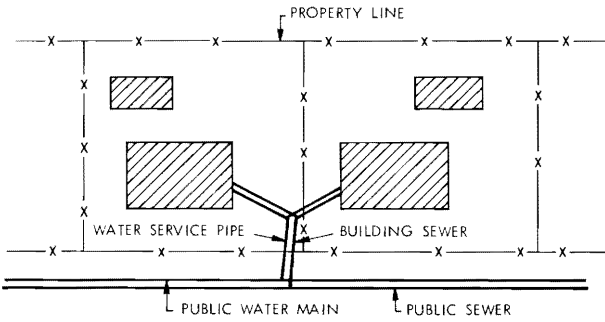

(d) Not permitted

BR 5249-14

The layout as shown in diagram (c) above may require special legal arrangements in some jurisdictions to ensure that access can be provided to all parts of the service pipes.

A-2.2.3.(3) Shower Drainage, Plan View

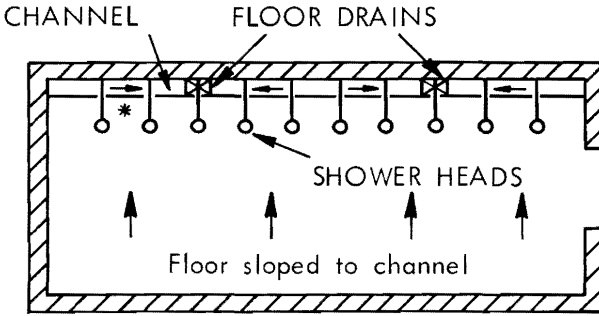

(a) Permitted

* Minimum distance between shower heads - 750 mm

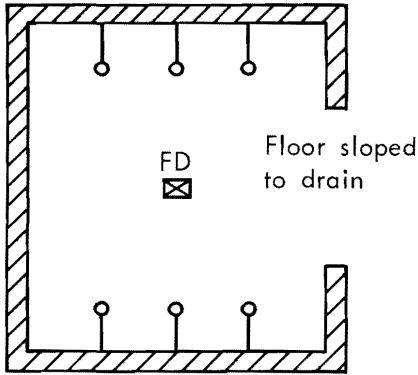

(b) Not permitted

BR 5249-15

A-2.2.4.

This does not preclude the use of a standing waste.

A-2.3.1.

A-2.3.1.(1) and (2) Trap Seal Depth and Trap Connections

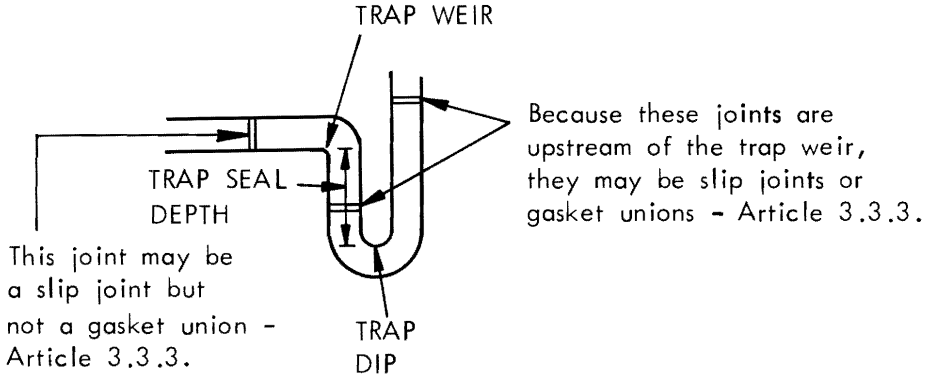

BR 5249-16

A-2.3.1.(3) Prohibited Traps

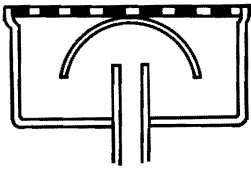

(a) Bell trap



(b) S trap

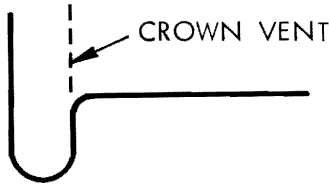

(c) Crown vented trap

BR 5249-17

Except for an S-trap standard, the S trap shown in diagram (b) above is prohibited by Clause 5.1.1.(2)(c) which limits the fall on fixture drains. Crown vented traps shown in diagram (d) are prohibited by Clause 5.6.3.(1)(a) which requires that the distance from the trap weir to the vent be not less than twice the size of the fixture drain.

A-2.4.1. T Fittings in Drainage Systems

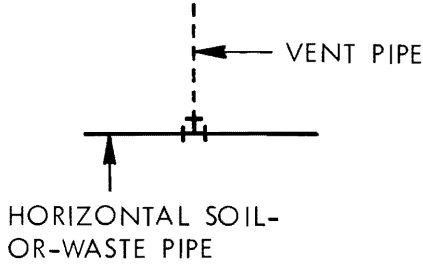

(a) Permitted

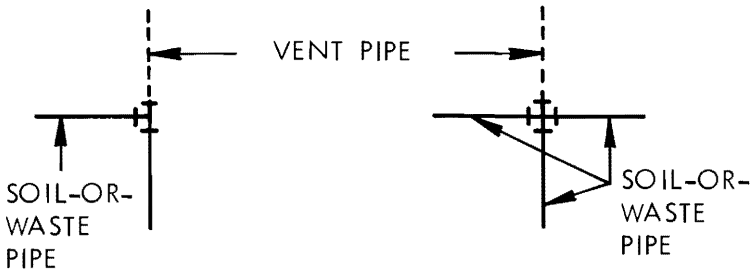

(b) Not Permitted

BR 5249-18

This prohibits the use of a cross fitting in a drainage system, but such fitting may be used in a venting system to connect 4 vent pipes. In a drainage system a T fitting can only be used as shown in diagram (a), and cannot be used as shown in diagram (b) because the T or cross fitting would change the direction of flow in the drainage system.

A-2.4.2.

A-2.4.2. Sanitary T Fittings in Drainage Systems

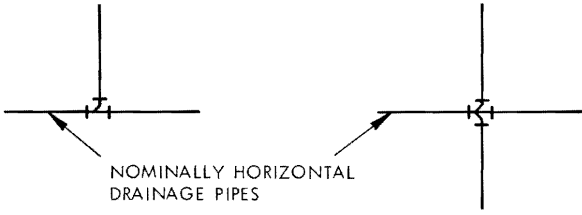
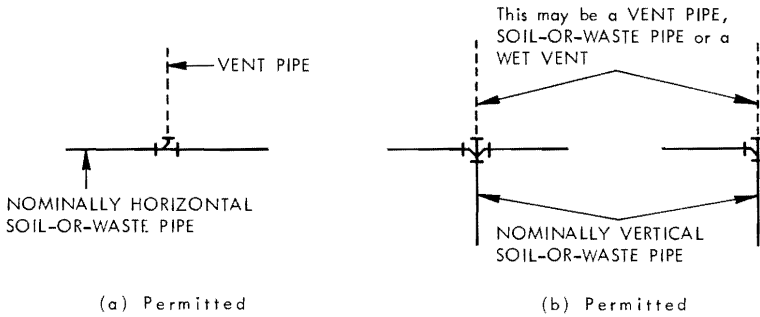

(c) Not Permitted (Use Combination Y and 1/8th bend)

BR 5249-19

A sanitary T fitting may be used to change the direction of flow in a drainage system from horizontal to vertical, but may not be used to change the direction of flow in a nominally horizontal drainage system. A combination Y and 1/8th bend fitting may also be used as shown in Figure (b).

A-2.5, A-2.6 and A-2.7

SUMMARY OF PIPE AND FITTINGS APPLICATIONS

| Type of Piping | Standard References | Code References | Use of Piping ⁽¹⁾ | | | | | | | | | | | | | | |
|---|-------------------------------|-----------------|------------------------------|-----------------------------|----------------|----------------|--------------|----------------------|-----|----------------|-------------|------------------|---|---|---|---|---|
| | | | Drainage System | | | Venting System | | Potable Water System | | | | | | | | | |
| | | | Above ground inside building | Under-ground under building | Building sewer | Above ground | Under-ground | Above ground | Hot | Under building | Underground | Outside building | | | | | |
| Asbestos-cement DWV pipe | | | | | | | | | | | | | | | | | |
| Type I Class 3000, sizes 8" to 24" | CGSB 34-GP-22M, or CSA B127.1 | 2.5.1.(1) | P | P | P | P | P | P | P | P | N | N | N | N | N | N | N |
| Type II Class 4000, sizes 3" to 24" | | 2.5.1.(1) | P | P | P | P | P | P | P | P | N | N | N | N | N | N | N |
| Asbestos-cement sewer pipe (non-pressure) | | | | | | | | | | | | | | | | | |
| Classes 1500, 2400, 3000, sizes 4", 5", 6" | CGSB 34-GP-23M, or CSA B127.2 | 2.5.1.(2) | N | P | P | P | N | P | P | P | N | N | N | N | N | N | N |
| Classes 1500, 2400, 3300, 4000, 5000, 6000, 7000, sizes 8" to 42.2" | CGSB 34-GP-9M | 2.5.1.(2) | N | P | P | P | N | P | P | P | N | N | N | N | N | N | N |
| Column 1 | 2 | 3 | 4 | 5 | 6 | 7 | 8 | 9 | 10 | 11 | 12 | | | | | | |

A-2.5, A-2.6 and A-2.7 (Cont'd)

| SUMMARY OF PIPE AND FITTINGS APPLICATIONS | | | | | | | | | | | | | | | | | | | | | | | |
|--|---------------------|-----------------|------------------------------|-----------------------------|----------------|----------------|--------------|----------------------|------|-----|----------------|------------------|---|---|---|---|---|---|---|---|------------------|------------------|------------------|
| Type of Piping | Standard References | Code References | Use of Piping ⁽¹⁾ | | | | | | | | | | | | | | | | | | | | |
| | | | Drainage System | | | Venting System | | Potable Water System | | | | | | | | | | | | | | | |
| | | | Above ground inside building | Under-ground under building | Building sewer | Above ground | Under-ground | Above ground | Cold | Hot | Under building | Outside building | | | | | | | | | | | |
| Asbestos-cement water pipe | | | | | | | | | | | | | | | | | | | | | | | |
| Class 100 psi Class 150 psi Class 200 psi | CGSB 34-GP-1M | 2.5.2. | N | N | N | N | N | N | N | N | N | N | N | N | N | N | N | N | N | N | P ⁽²⁾ | P ⁽²⁾ | |
| Concrete sewer pipe | CSA Series A257 | | | | | | | | | | | | | | | | | | | | | | |
| Sewer, storm drain and culvert | CSA A257.1 | 2.5.3. | N | P ⁽¹²⁾ | P | N | N | N | N | N | N | N | N | N | N | N | N | N | N | N | N | N | |
| Reinforced culvert, storm drain and sewer | CSA A257.2 | 2.5.3. | N | P ⁽¹²⁾ | P | N | N | N | N | N | N | N | N | N | N | N | N | N | N | N | N | N | |
| Vitrified clay pipe | CSA A60.1 | 2.5.4. | N | P | P | N | N | N | N | N | N | N | N | N | N | N | N | N | N | N | N | N | |
| Polyethylene water pipe | | | | | | | | | | | | | | | | | | | | | | | |
| Series 160 tube sizes with compression fittings | CSA B137.1 | 2.5.5. | N | N | N | N | N | N | N | N | N | N | N | N | N | N | N | N | N | N | N | P ⁽³⁾ | P ⁽³⁾ |
| Series 50, 75, 100 and 125 | | 2.5.5. | N | N | N | N | N | N | N | N | N | N | N | N | N | N | N | N | N | N | N | N | N |
| Column 1 | 2 | 3 | 4 | 5 | 6 | 7 | 8 | 9 | 10 | 11 | 12 | | | | | | | | | | | | |

A-2.5, A-2.6 and A-2.7 (Cont'd)

| SUMMARY OF PIPE AND FITTINGS APPLICATIONS | | | | | | | | | | | | | |
|--|---------------------|-------------------|------------------------------|-----------------------------|----------------|----------------------|--------------|--------------------------|--------------------------|------------------|------------------|------------------|------------------|
| Type of Piping | Standard References | Code References | Use of Piping ⁽¹⁾ | | | | | | | | | | |
| | | | Drainage System | | | Venting System | | Potable Water System | | | | | |
| | | | Above ground inside building | Under-ground under building | Building sewer | Above ground | Under-ground | Above ground | Hot | Under building | Outside building | | |
| Poly (vinyl chloride) (PVC) water pipe Series 80, 100, 125, 160 and 200 | CSA B137.3 | 2.5.6. | N | N | N | N | N | P | N | N | P ⁽⁴⁾ | P ⁽⁴⁾ | |
| Chlorinated poly (vinyl chloride) (CPVC) water pipe | CSA B137.6 | 2.5.7. | N | N | N | N | N | P ^{(5),(6),(7)} | P ^{(5),(6),(7)} | P ⁽⁷⁾ | P ⁽⁷⁾ | | P ⁽⁷⁾ |
| Polybutylene water pipe | CSA B137.8 | 2.5.8. | N | N | N | N | N | P ^{(5),(6)} | P ^{(5),(6)} | P | P | | P |
| Plastic sewer pipe | CSA B182.1 | 2.5.9.(1) | N | P | P | N | N | N | N | N | N | | N |
| Acrylonitrile-butadiene-styrene (ABS) DMV pipe | CSA B181.1 | 2.5.9. 2.5.10. | P ^{(5),(6)} | P | P | P ^{(5),(6)} | P | N | N | N | N | | N |
| Poly (vinyl chloride) (PVC) DWV pipe | CSA B181.2 | 2.5.9. 2.5.10. | P ^{(5),(6)} | P | P | P ^{(5),(6)} | P | N | N | N | N | | N |
| Cast-iron soil pipe | CSA B70 | 2.6.1. | P | P | P | P | P | N | N | N | N | | N |
| Column 1 | 2 | 3 | 4 | 5 | 6 | 7 | 8 | 9 | 10 | 11 | 12 | | 12 |

A-2.5, A-2.6 and A-2.7 (Cont'd)

| SUMMARY OF PIPE AND FITTINGS APPLICATIONS | | | | | | | | | | | |
|--|---|------------------|------------------------------|----------------------------|------------------|----------------|-------------|----------------------|------------------|------------------|------------------|
| Use of Piping ⁽¹⁾ | | | | | | | | | | | |
| Type of Piping | Standard References | Code References | Drainage System | | | Venting System | | Potable Water System | | | |
| | | | Above ground inside building | Underground under building | Building sewer | Above ground | Underground | Above ground | | Underground | |
| | | | | | | | | Cold | Hot | Under building | Outside building |
| Cast-iron water pipe | ANSI/AWWA C106/A21.6 (Gray Iron), or ANSI/AWWA C151/A21.51 (Ductile Iron) | 2.6.4. | P | P | P | P | P | P | P | P | P |
| Cast-iron screwed fittings | ANSI B16.4 (Cast iron) ANSI B16.3 (Malleable Iron) | 2.6.5. 2.6.6. | N | N | N | N | N | N | P | P | P |
| Welded and seamless steel galvanized pipe | ASTM A53 | 2.6.7. | P | N | N | P | N | P ⁽⁸⁾ | P ⁽⁸⁾ | P ⁽⁸⁾ | P ⁽⁸⁾ |
| Corrugated steel galvanized pipe | CAN3-G401 | 2.6.8. | N | N | P ⁽⁹⁾ | N | N | N | N | N | N |
| Sheet metal pipe ⁽¹⁰⁾ | — | 2.6.9. | N | N | N | N | N | N | N | N | N |
| Column 1 | 2 | 3 | 4 | 5 | 6 | 7 | 8 | 9 | 10 | 11 | 12 |

A-2.5, A-2.6 and A-2.7 (Cont'd)

| SUMMARY OF PIPE AND FITTINGS APPLICATIONS | | | | | | | | | | | |
|--|--|----------------------------|------------------------------|-----------------------------|----------------|------------------|----------------------|--------------|----------------|------------------|----|
| Type of Piping | Standard References | Code References | Use of Piping ⁽¹⁾ | | | | | | | | |
| | | | Drainage System | | Venting System | | Potable Water System | | | | |
| | | | Above ground inside building | Under-ground under building | Building sewer | Above ground | Under-ground | Above ground | Under building | Outside building | |
| Copper and brass pipe | ASTM B42 (copper) ASTM B43 (red brass) ANSI B16.24 | 2.7.1. 2.7.1. 2.7.2. | P | P | P | P | P | P | P | P | |
| Brass or bronze threaded water fittings | ANSI B16.15 | 2.7.3. | N | N | N | N | N | P | P | P | |
| Copper tube Types K and L hard | ASTM B88 | 2.7.4. | P | P | P | P | P | P | N | N | |
| Types K and L soft | ASTM B88 | 2.7.4. | N | N | N | N | N | P | P | P | |
| Type M hard | ASTM B88 | 2.7.4. | P | N | N | P | P | P | N | N | |
| Type M soft | ASTM B88 | 2.7.4. | N | N | N | N | N | N | N | N | |
| Type DWV | ASTM B306 | 2.7.4. | P ⁽¹⁾ | N | N | P ⁽¹⁾ | N | N | N | N | |
| Solder-joint drainage fittings | CSA B158.1 ANSI B16.29 | 2.7.5. | P | P | P | P | P | N | N | N | |
| Solder-joint water fittings | ANSI B16.18 ANSI B16.22 | 2.7.6. | N | N | N | P | P | P | P | P | |
| Column 1 | 2 | 3 | 4 | 5 | 6 | 7 | 8 | 9 | 10 | 11 | 12 |

A-2.5, A-2.6 and A-2.7 (Cont'd)

| SUMMARY OF PIPE AND FITTINGS APPLICATIONS | | | | | | | | | | | | | |
|--|---------------------|-----------------|------------------------------|-----------------------------|----------------|----------------|----------------------|----------------------|----|----------------|-------------|---|---|
| Type of Piping | Standard References | Code References | Use of Piping ⁽¹⁾ | | | | | | | | | | |
| | | | Drainage System | | | Venting System | | Potable Water System | | | | | |
| | | | Above ground inside building | Under-ground under building | Building sewer | Above ground | Under-ground | Above ground | | Under building | Underground | | |
| Lead waste pipe | CSA B67 | 2.7.8. | P ^{(5),(6)} | P | N | N | P ^{(5),(6)} | P | N | N | N | N | N |
| Column 1 | 2 | 3 | 4 | 5 | 6 | 7 | 8 | 9 | 10 | 11 | 12 | | |

Notes to Table:

N — Not permitted. P — Permitted

(1) Where fire stops are pierced by pipes, the integrity of the fire stop must be maintained.

(2) Cold water only.

(3) Permitted only for water service pipe.

(4) Not permitted in hot water systems.

(5) Combustible piping in noncombustible construction is subject to the requirements of Article 3.1.4.5.(5) of the National Building Code 1985.

(6) Combustible piping that penetrates a fire separation is subject to the requirements in Articles 3.1.7.7., 9.10.9.10. and 9.10.9.26. of the National Building Code 1985.

(7) Not to exceed design temperature and design pressure in Sentence 2.5.7.(2).

(8) Permitted only in buildings of industrial occupancy as described in the National Building Code 1985, or the repair of existing galvanized steel piping systems.

(9) Permitted underground only in a storm drainage system.

(10) Permitted only for an external leader.

(11) Not permitted for the fixture drain or vent below the flood level rim of a flush valve operated urinal.

(12) Gasketed joints required.

A-2.5.3.(4) Concrete Fittings. Concrete fittings fabricated on the site from lengths of pipe may have proved to have been acceptable on the basis of past performances in some localities, and their acceptance under Article 1.4.3. of the Code may be warranted.

A-2.6.7.(3) Galvanized Steel Pipe. The use of galvanized steel pipe in a water distribution system may have proved to have been acceptable on the basis of past performances in some localities, and its acceptance under Article 1.4.3. of this Code may be warranted.

A-2.9.5. Saddle Hubs or Fittings. Saddle hubs or fittings may have proved to have been acceptable on the basis of past performances in some localities, and their acceptance under Article 1.4.3. of this Code may be warranted.

A-2.9.8.(3) Bubblers. Bubblers installed on other than drinking fountains may have proved to have been acceptable on the basis of past performances in some localities, and their acceptance under Article 1.4.3. of this Code may be warranted.

A-2.9.9.(1) Backflow Preventers. Information on the selection, installation, maintenance and field testing of backflow preventers can be found in CSA B64.10, "Backflow Prevention Devices — Selection, Installation, Maintenance and Field Testing."

A-3.3.9. Linear Expansion (See below.)

A-3.3.11.(2) Air Break

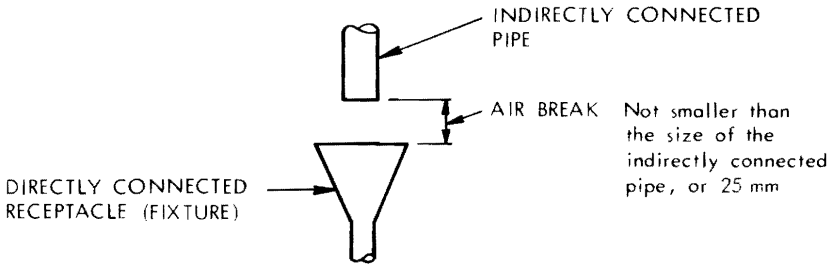

BR 5249-21

A-3.3.9.

A-3.3.9. Linear Expansion

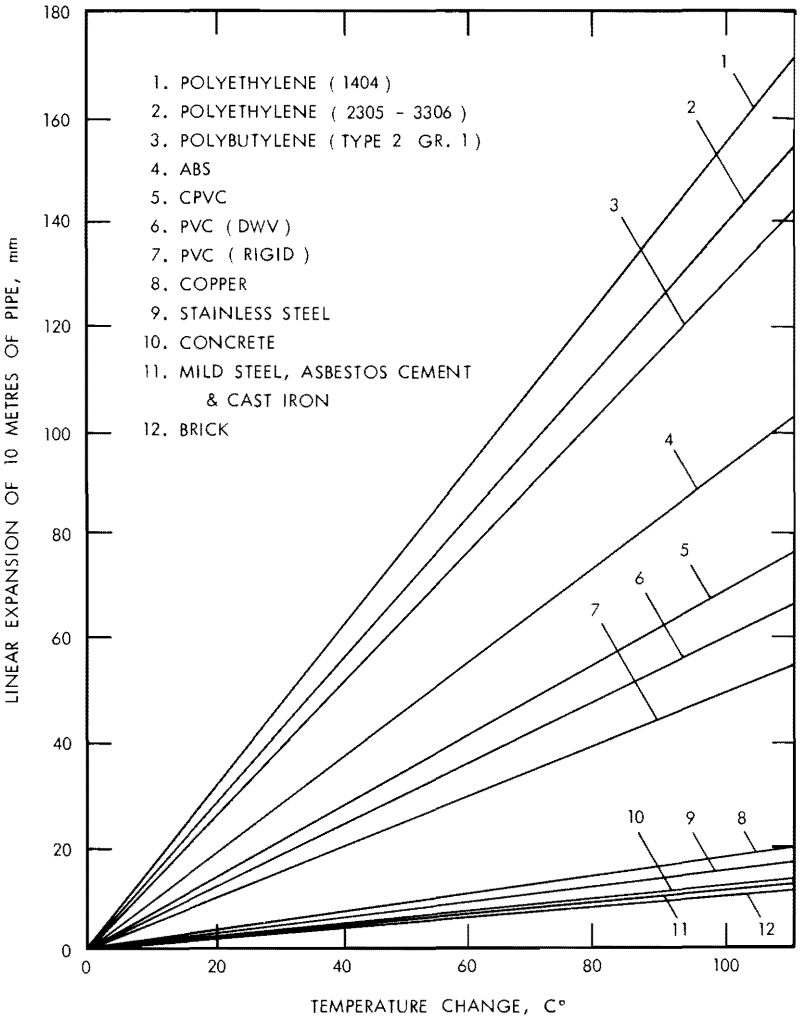

BR 5563-9

Example: To determine the expansion of 20 m of ABS pipe for a temperature change from 10°C to 60°C.

- Temperature change = 60 – 10 = 50 C°,
- Enter the chart at 50 C°, read up to ABS line, and then across to the mm scale = 47 mm/10 of pipe,

— ∴ change in length of 20 m of pipe = $\frac{20}{10} \times 47 = 94$ mm.

A-3.4.6.(1) Support for Underground Piping

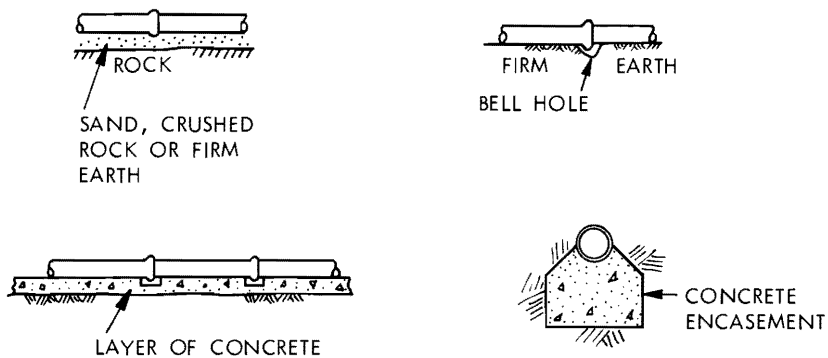

(a) Permitted

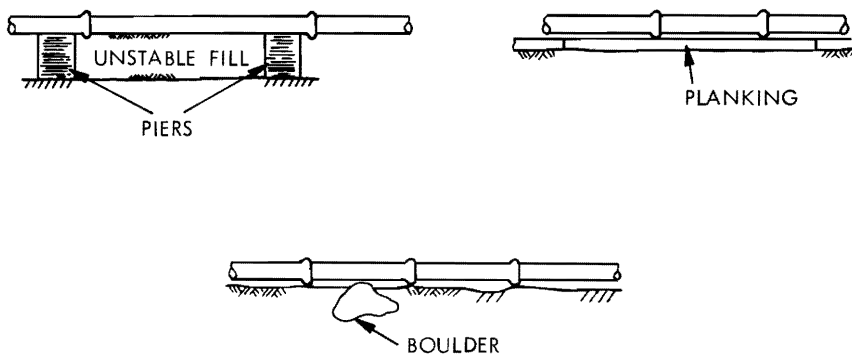

(b) Not permitted

BR 5249-22

See explanation for Subsection 3.5 for additional protection required for underground pipes. Permitted installations are shown in diagram (a). The methods of support shown in diagram (b) are not permitted because the base does not provide firm and continuous support for the pipe.

A-3.5.1.

A-3.5.1. Backfilling of Pipe Trench

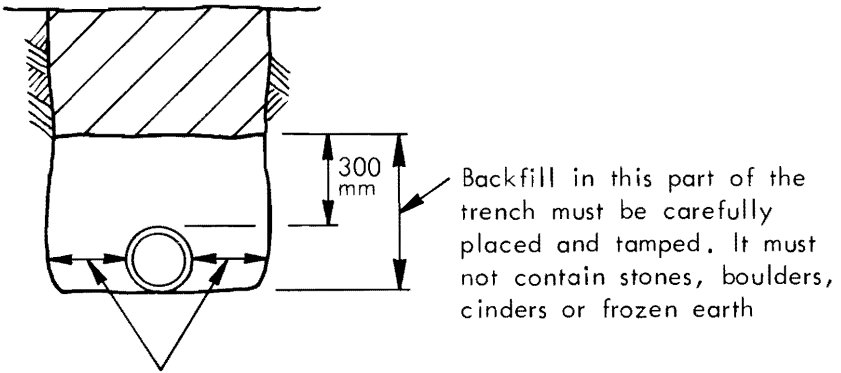

This part of the trench should be as narrow as proper jointing and backfill will permit

BR 5249-23

Stronger pipes may be required in deep fill or under driveways, parking lots, etc., and compaction for the full depth of the trench may be necessary.

A-3.5.2. Protection of Underground Non-Metallic Pipes

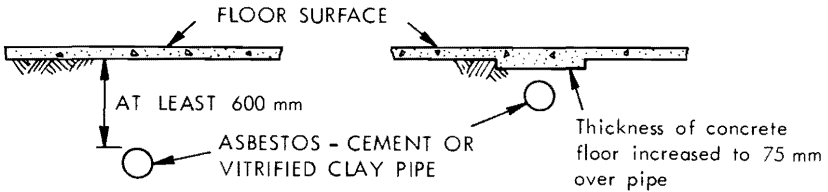

(a) Concrete floors less than 75 mm thick

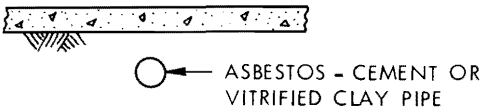

(b) Concrete floor 75 mm or more in thickness (no protection required)

BR 5249-24

A-4.2.1.(1)(a) and (d) Indirect Connections

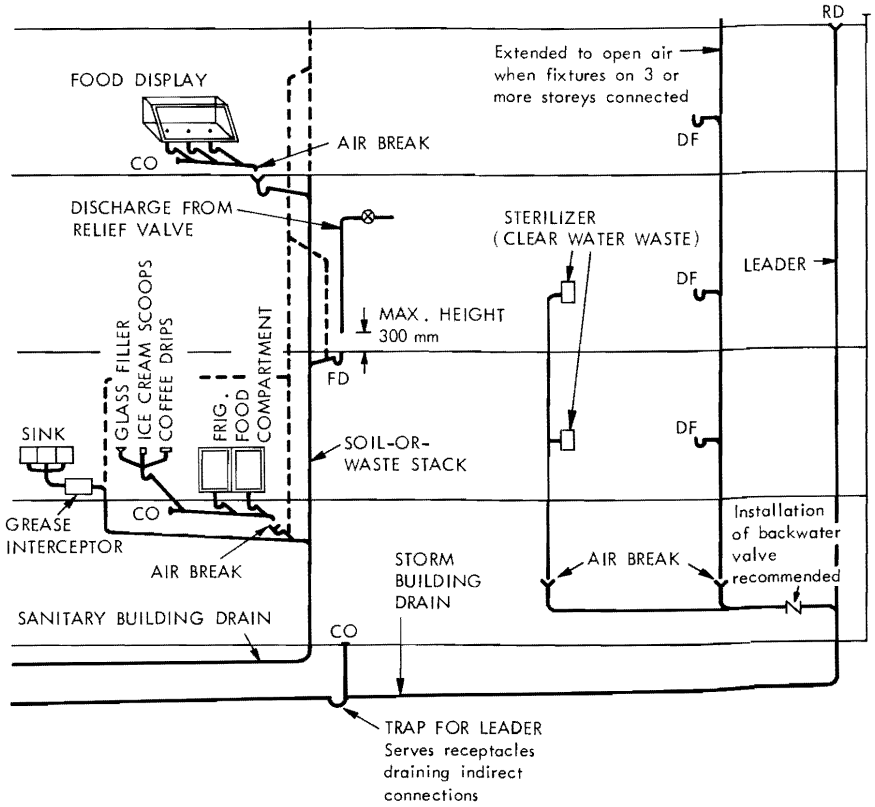

BR 5249-25

See Sentence 4.5.1.(4) for trapping requirements for indirectly connected fixtures.
 See Sentence 4.7.1.(9) for cleanouts on drip pipes for food receptacles or display cases.

A-4.2.1.

A-4.2.1.(1)(e), (f) and (g) Fixture Connections to Vent Pipes

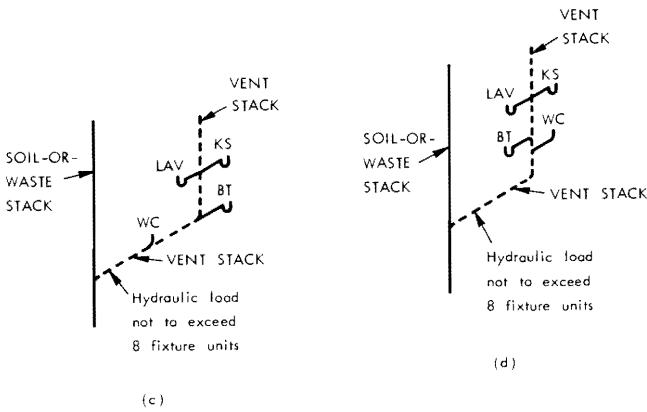
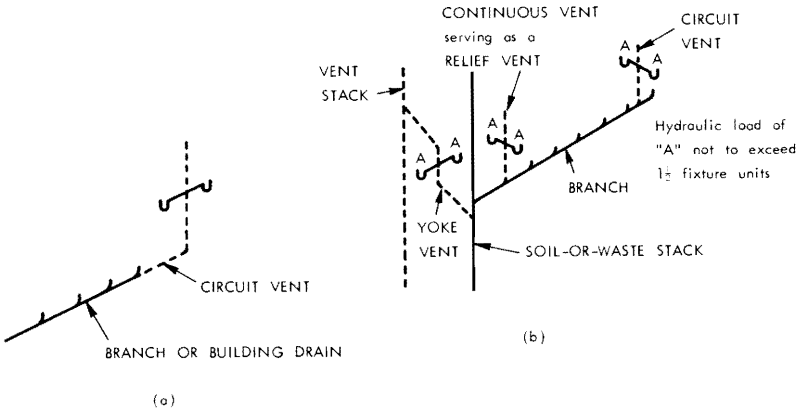

BR 5249-26

When 1 or more fixture drains are connected to a vent pipe, the vent pipe becomes a wet vent. It must then conform to all the requirements that can apply to it as a drainage pipe and a vent pipe.

See A-5.2.2.(1), (2) and (3) for further information regarding Clause 4.2.1.(1)(e).

A-4.2.1.(2) Soil-or-Waste Pipe Connections

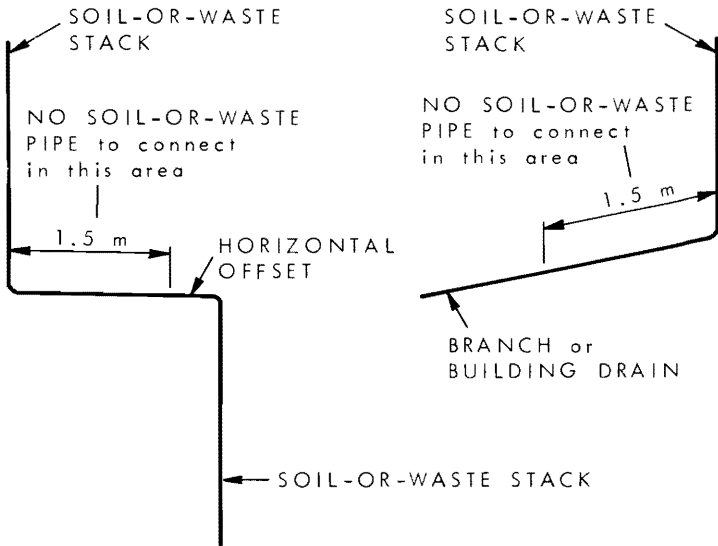

(a) Connection to nominally horizontal offset

(b) Connection to nominally horizontal soil-or-waste pipe

BR 5563-1

A-4.4.3.

A-4.4.3.(1) Grease Interceptors. Grease interceptors may be required when it is considered that the discharge of excessive grease may impair the drainage system. Information on the design, sizing and replacement of grease interceptors can be found in ASPE 1977-78, Data Book, Volume 2, "Special Plumbing Systems Design."

A-4.5.1.(2) Trapping of Sinks and Laundry Trays

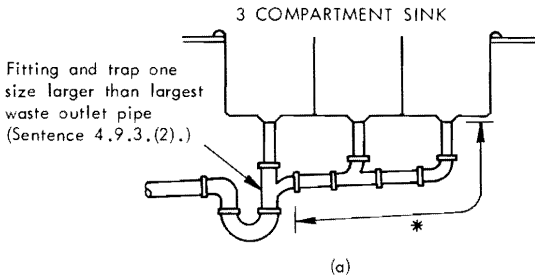

* DEVELOPED LENGTH not to exceed 900 mm (Article 4.8.2.)

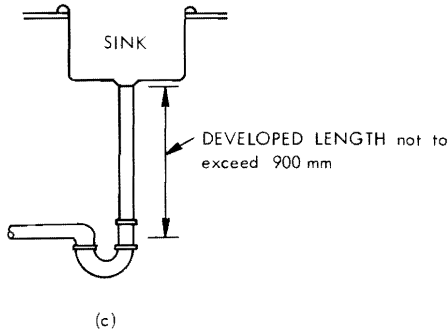
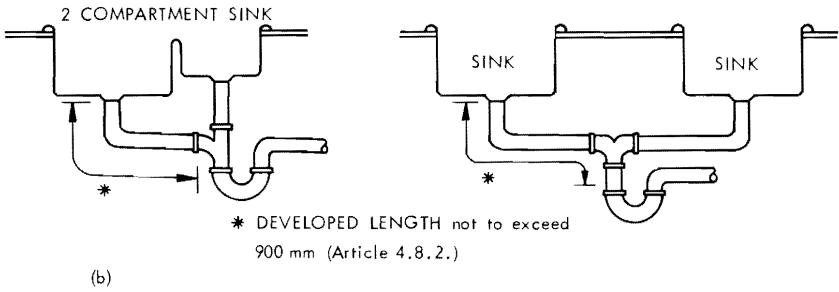

BR 5249-27

A-4.5.1.(3) Single Traps for Fixture Groups

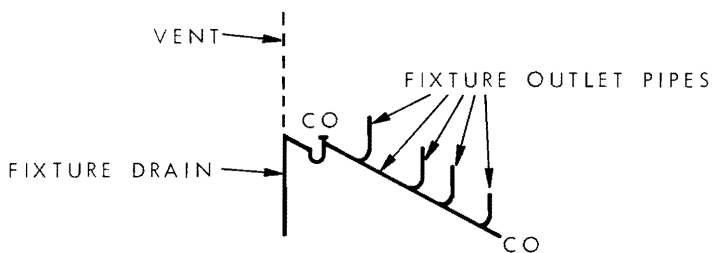

(a) Laboratory sinks or washing machines

VENT not required for floor drains if the installation conforms to Sentence 5.1.1. (2)

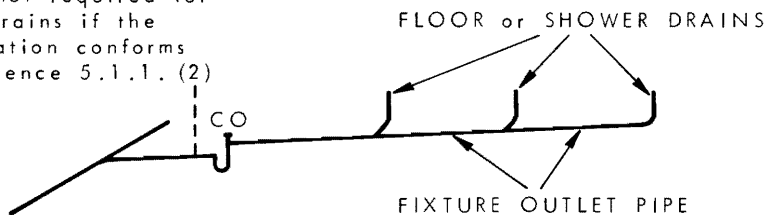

(b) Floor drains and shower drains

BR 5563-2

A-4.5.1.

A-4.5.1.(5) Location of Trap or Interceptor

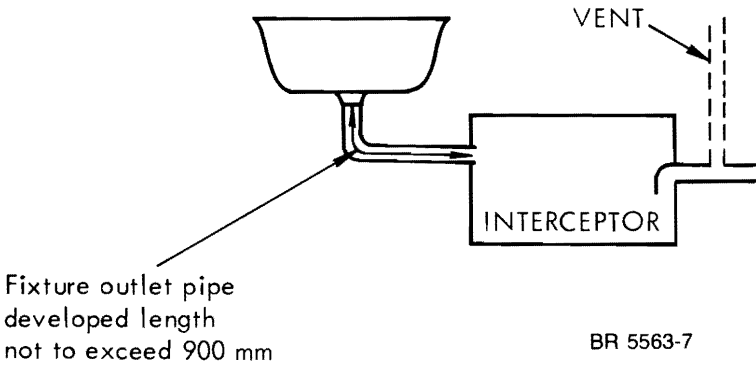

An interceptor that replaces a trap must be vented in the same way as the trap it replaces. (See A-4.2.1.(1)(a) and (d). Where an interceptor other than an oil interceptor serves a group of fixtures requiring more than 1 trap, each fixture must be properly trapped and vented. (See Article 5.5.2. for venting of oil interceptors.)

A-4.5.2.(1). When an untrapped leader drains to a combined building sewer, clearance requirements are the same as for vent terminals. (See A-5.6.5.(3).)

A-4.5.3. Subsoil Drainage Connections

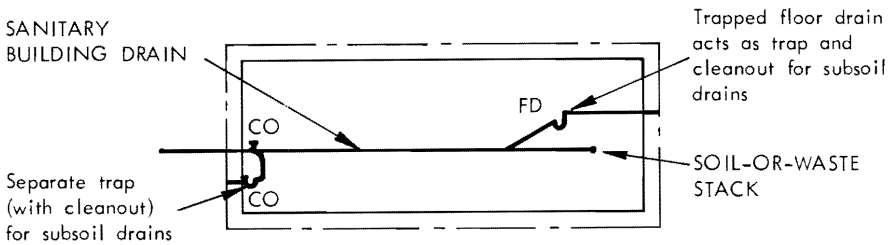

(a) Connections to sanitary drainage system (Plan View)

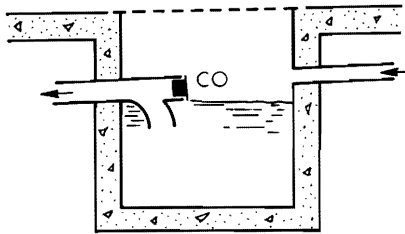

(b) Trapped sump

BR 5249-28

This Code does not regulate the installation of subsoil drainage pipes, but does regulate the connection of such pipes to the plumbing system. The intent of this Article is to place a trap between the subsoil drainage pipe and the sanitary drainage system. The cleanout must be installed in accordance with Sentence 4.7.1.(2). A trap or sump may be provided specifically for the subsoil drains, or advantage may be taken of the trap of a floor drain or storm water sump as shown above.

A-4.5.4.(1) Location of Building Traps

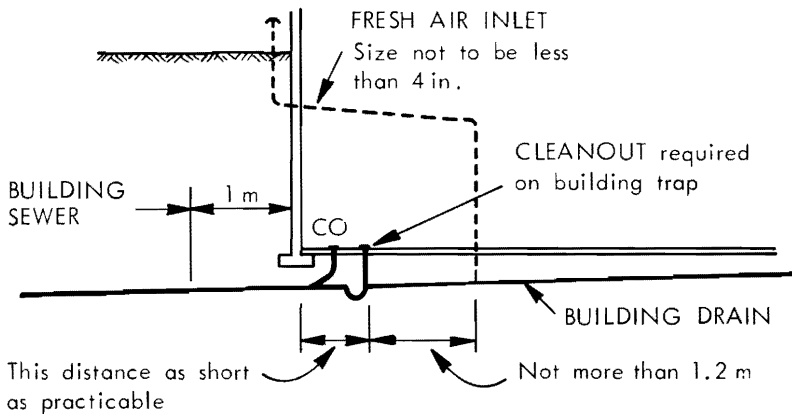

(a) Building trap inside building

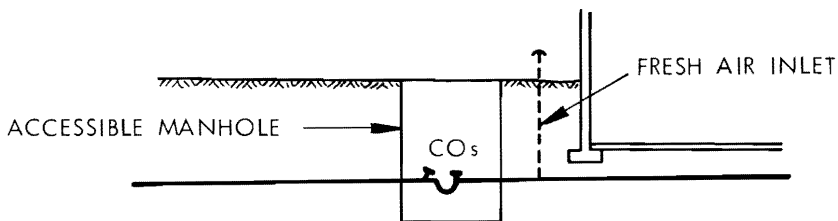

(b) Building trap outside building

BR 5249-29

A-4.5.5.

A-4.5.5. Maintaining Trap Seals

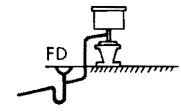

(a) Flush tank

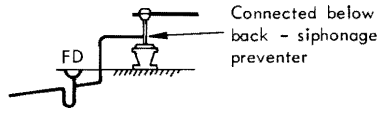

(b) Flush valve

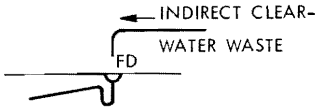

(c) Indirect waste

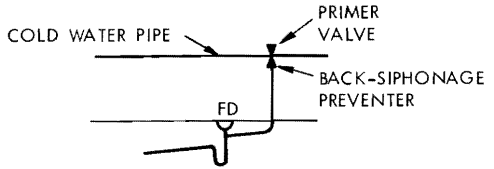

(d) Trap seal primer

BR 5249-30

Periodic manual replenishment of the water in a trap is considered to be an equally effective means of maintaining the trap seal in floor drains in residences.

A-4.6.1.(2) Combined Building Drains. Combined building drains may have proved to have been acceptable on the basis of past performance in some localities, and their acceptance under Article 1.4.3. of this Code may be warranted.

A-4.6.3. Arrangement of Piping at Sump

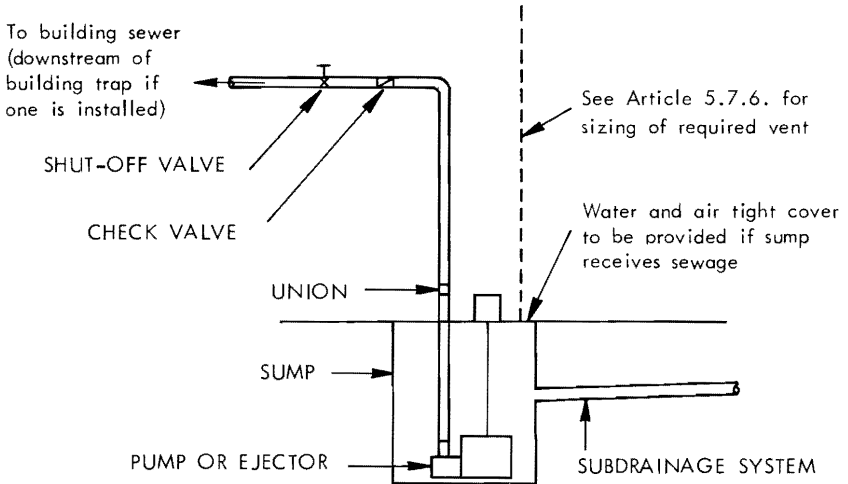

BR 5249-31

In most installations controls will be installed in conjunction with a float to automatically empty the sump. If such controls are not provided, the capacity of the sump should equal the maximum inflow to the sump that is expected to occur during any 24 h period.

A-4.6.4.(1) Backwater Valve or Gate Valve. The installation of a backwater valve or a gate valve in a building drain or in a building sewer may have proved to have been acceptable on the basis of past performance in some localities, and their acceptance under Article 1.4.3. of this Code may be warranted.

A-4.6.4.(5) Protection from Backflow Caused by Surge

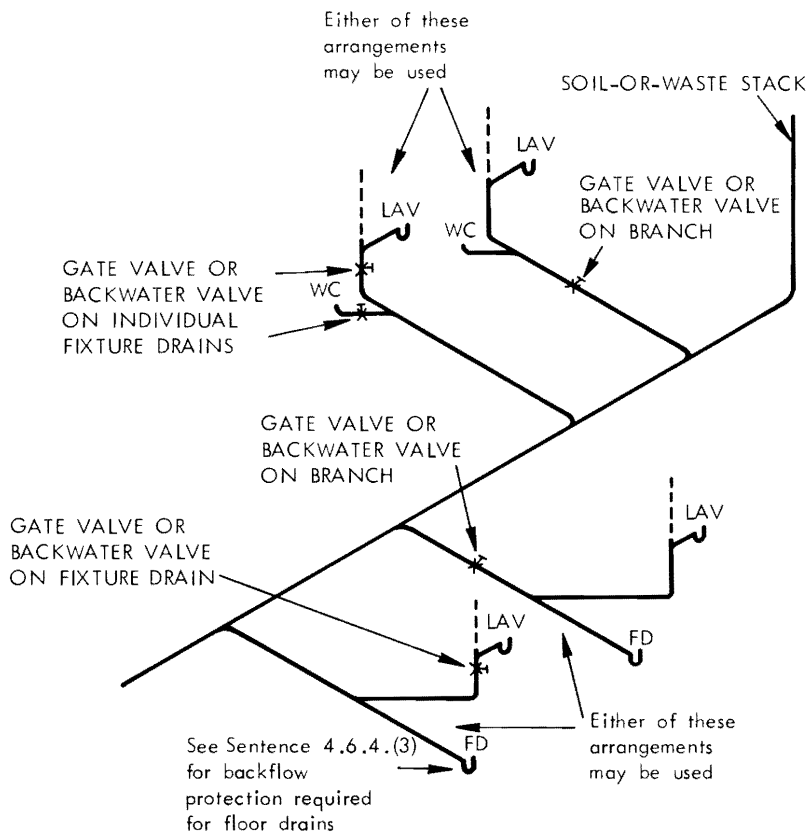

BR 5249-32

These requirements are intended to apply when in the opinion of the authority having jurisdiction there is danger of backup from a public sewer.

A-4.7.1.(1). A trap cleanout plug is not acceptable as a cleanout for the fixture drain, hence either a separate cleanout or a trap with a removable trap dip must be installed.

A-4.7.1.

A-4.7.1.(9) Cleanouts for Food Receptacle Drip Pipes

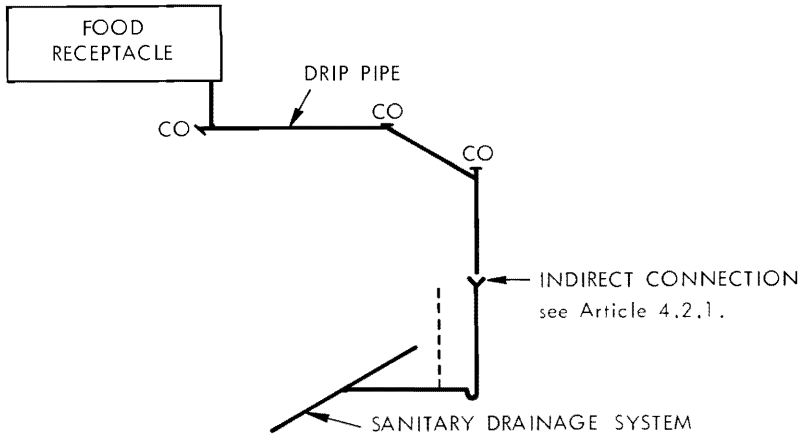

BR 5249-33

A-4.8.1. Although slopes below 1 in 100 are permitted for pipes over 4 in., it is recommended that they be used only where necessary. Steeper slopes and higher velocities will help to keep pipes clean by moving heavier solids that might tend to clog the pipes.

A-4.9.3.(2). Fixture outlet pipes that are common to 2 or 3 compartments or fixtures are sometimes referred to as continuous wastes and are not considered to be branches. (See also explanation for Sentence 4.5.1.(2).)

A-4.10 Determination of Hydraulic Loads and Drainage Pipe Sizes

Hydraulic Loads

The hydraulic load that is imposed by a fixture is represented by a factor called a fixture unit. Fixture units are dimensionless and take into account the rate of discharge, time of discharge and frequency of discharge of the fixture.

Confusion often arises when attempts are made to convert fixture units to litres per second because there is no straightforward relationship between the two. The proportion of the total number of fixtures that can be expected to discharge simultaneously in a large system is smaller than in a small system. For example, doubling the number of fixtures in a system will not double the peak flow that the system must carry, although of course the flow will be increased somewhat. The following curve shows the relationship that was used in constructing the tables of capacities of stacks, branches, sanitary building drains and sanitary building sewers (Tables 4.10.B. to 4.10.D.).

Although the curve below was used to prepare the Code tables, it was not included in the Canadian Plumbing Code. Instead, a single approximate conversion factor is given in the Code so that a continuous flow from a fixture may be converted from litres per second to fixture units in order to determine the total hydraulic load on the sanitary drainage system. The conversion factor which is given in Sentence 4.10.3.(1) is 26.4 fixture units per litres per second. The discharge from a continuous flow fixture in litres per second when multiplied by 26.4 gives the hydraulic load in fixture units, and that load is added to the fixture unit load from other fixtures to give the total load that the sanitary drainage pipe must carry.

A-4.10 (Cont'd)

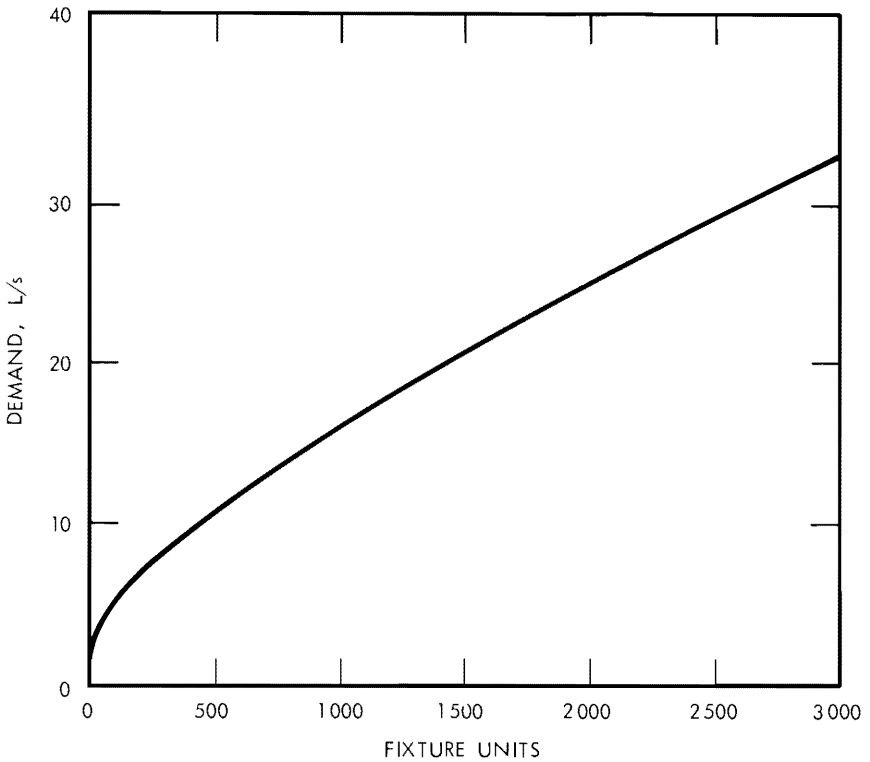

BR 5249-34

The hydraulic load that is produced by storm water runoff depends both on the size of the area that is drained and local rainfall intensity. The capacities of storm drainage pipes and combined sewers in Tables 4.10.E. to 4.10.G. have been expressed in terms of the number of litres that they can carry when the local rainfall intensity is 1 mm in 15 min. The hydraulic load for a particular location is obtained by simply multiplying the rainfall intensity figure given in Chapter 1 of the "Supplement to the NBC 1985" by the actual area drained as specified in Sentence 4.10.4.(1).

When plumbing fixtures are connected to a combined sewer, the hydraulic load from the fixtures must be converted from fixture units to litres or, in the case of continuous flow, from litres per second to litres so that these loads can be added to the hydraulic loads from roofs and paved surfaces. As already pointed out, the relationship between fixture units and litres per second and, consequently, the relationship between fixture units and litres is not straightforward, and an approximate conversion factor has been adopted. The conversion factor which is given in Sentence 4.10.5.(1) is 9.1 L/fixture unit, except where the load is less than 260 fixture units when a round figure of 2360 L is to be used. In the case of continuous flow fixtures that are connected to combined sewers or storm sewers, the conversion factor given in Sentence 4.10.3.(2) is 900 L per L/s. This conversion factor is not an approximation but is an exact calculation.

A-4.10.

A-4.10 (Cont'd)

It should be noted carefully that the conversion factors given in Sentences 4.10.3.(1) and 4.10.5.(1) are designed to convert in 1 direction only, and must not be used to convert from fixture units to litres per second in the one instance nor from litres to fixture units in the other instance.

In summary it should be noted that

- (a) in sanitary drainage systems all hydraulic loads are converted to fixture units, and
- (b) in storm drainage systems or combined drainage systems all hydraulic loads are converted to litres.

Procedure for Selecting Pipe Sizes

The following is an outline, with examples, of the procedures to be followed in determining the size of each section of drainage piping.

1. Sanitary drainage pipes, for example, branches, stacks, building drains or building sewers
 - (a) Determine the load in fixture units from all fixtures except continuous flow fixtures,
 - (b) Determine the load in litres per second from all continuous flow fixtures and multiply the number of litres per second by 26.4 to obtain the number of fixture units,
 - (c) Add loads (a) and (b) to obtain the total hydraulic load on pipe in fixture units, and
 - (d) Consult the appropriate table from Tables 4.10.B., 4.10.C. or 4.10.D. and select the pipe size.
(Note that no pipe size can be smaller than that permitted in Subsection 4.9.)
2. Storm drainage pipes, for example, gutters, leaders, horizontal pipes, building drains or building sewers
 - (a) Determine the area in square metres of roofs and paved surfaces according to Sentence 4.10.4.(1),
 - (b) Determine the local rainfall intensity (15 min rainfall) from Chapter I of the "Supplement to the NBC 1985,"
 - (c) Multiply (a) by (b) to obtain the hydraulic load in litres,
 - (d) If a fixture discharges a continuous flow to the storm system, multiply its load in litres per second by 900 to obtain the hydraulic load in litres,
 - (e) Add loads (c) and (d) to obtain the total hydraulic load on the pipe in litres, and
 - (f) Consult the appropriate table from Tables 4.10.E., 4.10.F. or 4.10.G. and select pipe or gutter size.
(Note that no pipe size can be smaller than that permitted in Subsection 4.9.)
3. Combined drainage pipes, for example, building sewers
 - (a) Determine the total load in fixture units from all fixtures except continuous flow fixtures,
 - (b) If the fixture unit load exceeds 260, multiply it by 9.1 to determine the equivalent hydraulic load in litres. If the fixture unit load is 260 or fewer fixture units, the hydraulic load is 2 360 L,
 - (c) Obtain the hydraulic load from roofs and paved surfaces in the same manner as for storm drains (see 2(a), (b) and (c)),
 - (d) Obtain the hydraulic load in litres from any continuous flow source that is connected to the sanitary or storm drainage system in the same manner as for storm drainage pipes (see 2(d)),
 - (e) Add hydraulic loads (b), (c) and (d) to obtain the total hydraulic load on pipe in litres, and
 - (f) Consult Table 4.10.E. and select the pipe size.
(Note that no pipe can be smaller than that permitted in Subsection 4.9.)

A-4.10 (Cont'd)

Examples

Example I: Determination of the size of storm drainage components for building shown in the following 2 diagrams:

Storm Drainage Areas (Example I)

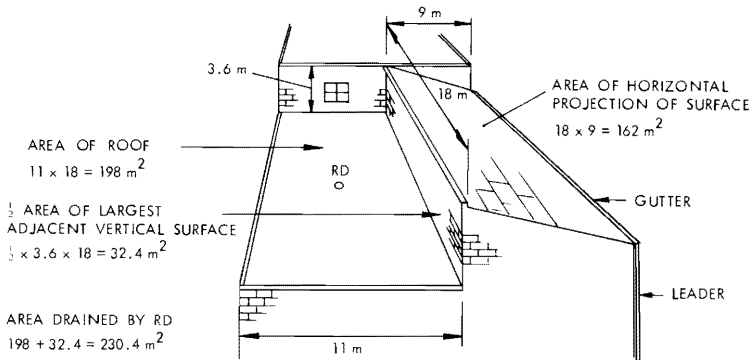

BR 5249-35

Step No. 1 Determine the hydraulic load from the roofs.

Area drained by gutter 162 m²

Area drained by roof drain 230.4 m²

If the local rainfall intensity is 25 mm

the load on the gutter (leader No. 2)

is (25 x 162) 4 050 L

the load on the roof drain (leader No. 1)

is (25 x 230.4) 5 760 L

If the local rainfall intensity is 15 mm

the load on the gutter (leader No. 2)

is (15 x 162) 2 430 L

the load on the roof drain (leader No. 1)

is (15 x 230.4) 3 456 L

A-4.10.

A-4.10 (Cont'd)

Step No. 2 Determine the size of storm drainage components.

Using the appropriate hydraulic loads, the size of storm drainage components can be determined from Tables 4.10.E., 4.10.F. and 4.10.G. These values are tabulated in the Table below for rainfall intensities of 25 mm and 15 mm in 15 min.

Storm Drainage Components (Example I) (Elevation View)

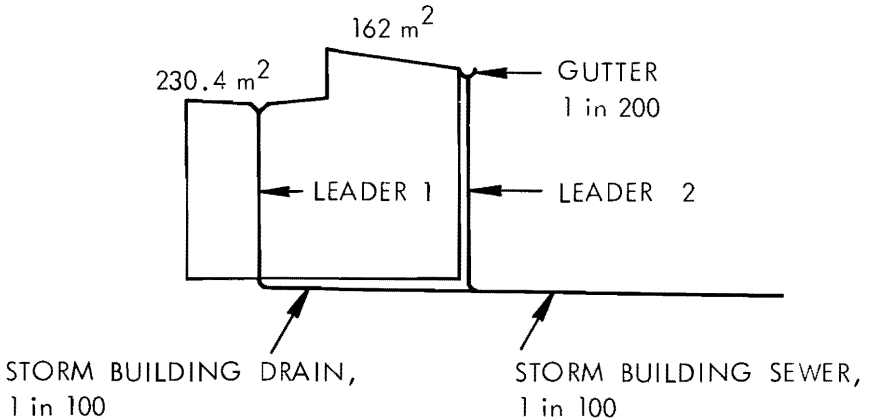

BR 5249-36

Storm Drainage Pipe Sizes (Example I)

| | Area Drained, m ² | 15 min Rainfall Intensity, mm | | | | Reference Table No. |
|----------------------|------------------------------|-------------------------------|-----------|-------------------|-----------|---------------------|
| | | 25 | | 15 | | |
| | | Hydraulic Load, L | Size, in. | Hydraulic Load, L | Size, in. | |
| Roof drain leader | 230.4 | 5 760 | 4 | 3 456 | 3 | 4.10.G. |
| Gutter | 162 | 4 050 | 8 | 2 430 | 7 | 4.10.F. |
| Gutter leader | 162 | 4 050 | 3 | 2 430 | 2½ | 4.10.G. |
| Storm building drain | 230.4 | 5 760 | 5 | 3 456 | 4 | 4.10.E. |
| Storm building sewer | 395.8 | 9 895 | 6 | 5 936 | 5 | 4.10.E. |
| Column 1 | 2 | 3 | 4 | 5 | 6 | 7 |

A-4.10 (Cont'd)**Example II: Determination of Size of Drainage Pipes for Buildings.**

The following diagram represents an office building with washrooms for men and women, a drinking fountain and cleaner's closet on each typical floor. The equipment room with facilities is located in the basement. The building is 18 m by 30 m and is to be built in Kitchener, Ontario.

A. Hydraulic Load per Typical Floor

| | | |
|------------|---|-----------------------|
| 5 WC @ 6 | = | 30 fixture units |
| 2 UR @ 1½ | = | 3 fixture units |
| 4 LAV @ 1½ | = | 6 fixture units |
| 2 FD @ 3 | = | 6 fixture units |
| 1 FS @ 3 | = | 3 fixture units |
| 1 DF @ 1 | = | <u>1 fixture unit</u> |
| | | 49 fixture units |

The reader is left to calculate the size of the branches, one of which must be 4 in. and another 3 in. (see Subsection 4.9). Therefore the smallest part of the stack must be 4 in.

B. Hydraulic Load on Stack

| | | |
|------------------------------|---|-------------------|
| 5 storeys @ 49 fixture units | = | 245 fixture units |
|------------------------------|---|-------------------|

Table 4.10.B. Column 3 permits 4 in. pipe. Use 4 in. pipe

C. Hydraulic Load on Basement Branch

| | | |
|----------------------|---|------------------------|
| 1 WC @ 6 | = | 6 fixture units |
| 1 LAV @ 1 | = | 1 fixture unit |
| 2 FD @ 3 | = | 6 fixture units |
| 1 FS @ 3 | = | 3 fixture units |
| Semi-Continuous Flow | | |
| 0.23 L/s x 26.4 | = | <u>6 fixture units</u> |
| | | 22 fixture units |

Table 4.10.C. Column 2 permits 3 in. pipe. Use 3 in. pipe

A-4.10.

A-4.10 (Cont'd) Building Drainage System (Example II)

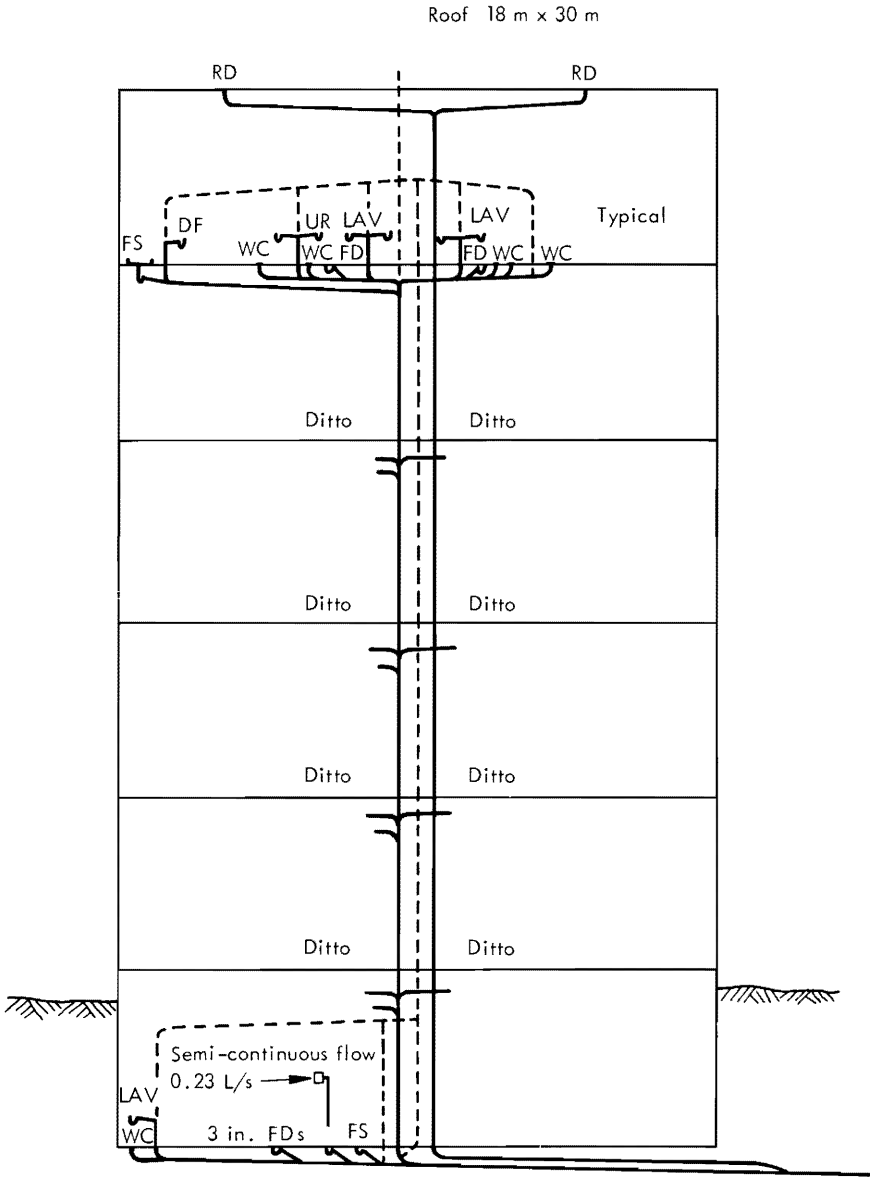

BR 5249-37

Building drainage system (Example II)

A-4.10 (Cont'd)

D. Hydraulic Load on Building Drain

| | |
|--------------------------|-------------------------|
| From soil-or-waste stack | 245 fixture units |
| From basement branch | <u>22 fixture units</u> |
| | 267 fixture units |

Table 4.10.D. Column 6 @ 1 in 50, a 4 in. pipe will carry 240 fixture units

Table 4.10.D. Column 7 @ 1 in 25, a 4 in. pipe will carry 300 fixture units

For practical reasons use a 4 in. pipe at a slope of not less than 1 in 32.

E. Storm Load

Area of roof $18 \times 30 = 540 \text{ m}^2$

Rainfall intensity for Kitchener from Chapter 1 of the "Supplement to the NBC 1985" is 28 mm in 15 min.

Total hydraulic storm load = $28 \times 540 = 15\,120 \text{ L}$

Storm load on each roof drain $15\,120/2 = 7\,560 \text{ L}$

F. Size of Horizontal Leaders

Table 4.10.E. Column 8 @ 1 in 25, a 4 in. pipe will carry a load of 8 430 L

Table 4.10.E. Column 7 @ 1 in 100, a 5 in. pipe will carry a load of 7 650 L

Table 4.10.E. Column 4 @ 1 in 133, a 6 in. pipe will carry a load of 10 700 L

Therefore use a 5 in. pipe at a slope of 1 in 100.

G. Size of Vertical Leader

Table 4.10.G. Column 2 would permit a 5 in. pipe (19 500 L) but they are not readily available.

For practical reasons use a 6 in. pipe.

H. Size of Storm Building Drains

Since a drainage pipe cannot be smaller than any upstream pipes, the storm building drain must be at least 6 in. Referring again to Table 4.10.E., we see that a 6 in. pipe will carry a hydraulic load of 17 600 L at a slope of 1 in 50. Therefore use a 6 in. pipe at a slightly higher slope.

I. Size of Combined Building Sewer

| | |
|---|----------|
| (a) Total sanitary load excluding semi-continuous flow 26l fixture units converted to litres (Clause 4.10.5(1)(b)) x 9.1 = | 2 375 L |
| (b) Semi-continuous flow 0.23 L/s converted to litres (Sentence 4.10.3(2)) x 900 = | 207 L |
| (c) Storm load | 15 120 L |

| | |
|---------------------------|----------|
| Total hydraulic load..... | 19 702 L |
|---------------------------|----------|

Referring to Table 4.10.E. @ 1 in 50, a 6 in. pipe will carry 17 600 L

Referring to Table 4.10.E. @ 1 in 25, a 6 in. pipe will carry 24 900 L

Therefore use a 6 in. pipe at a slope of not less than 1 in 32.

A-4.10.4.

A-4.10.4.(1). Climate information on rainfall intensities for various cities can be found in Chapter 1 of the "Supplement to the NBC 1985."

When calculating the hydraulic load from a roof or paved surface, it should be noted that 1 mm depth of water on 1 m² of surface is equivalent to 1 L.

A-5.1.1.(2) Trapping of Floor Drains

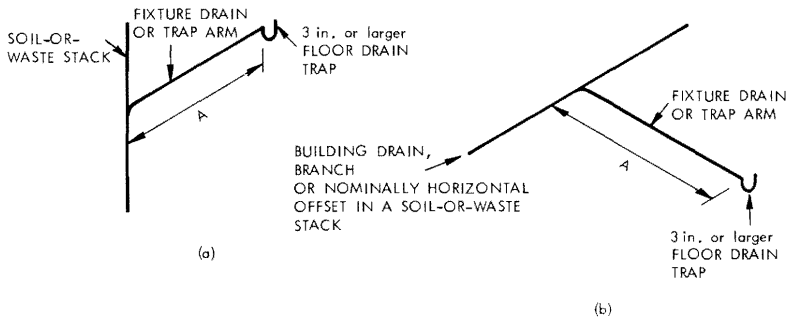

Length of "A" must be at least 450 mm and its fall shall not exceed the size of the pipe

See also explanation of Sentence 5.6.3. (1) for fall on fixture drain

BR 5249-38

A-5.1.1.(3) Venting not Required

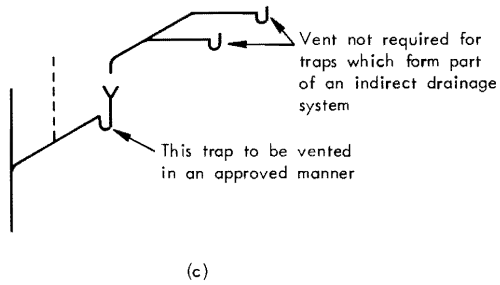
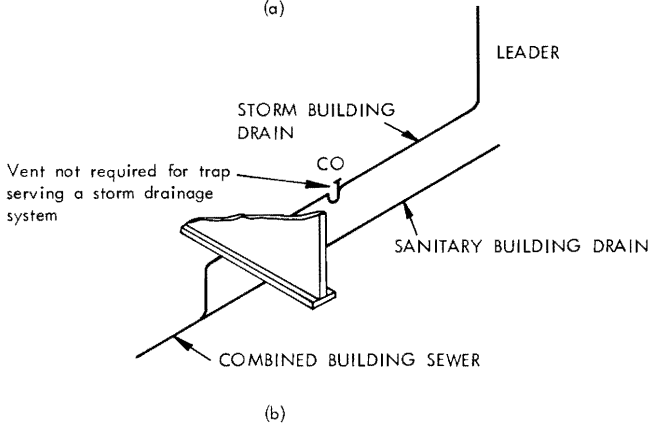
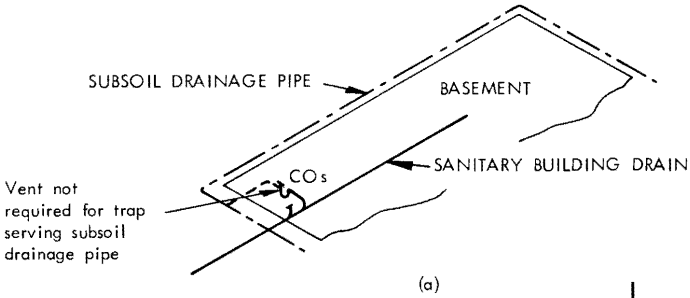

BR 5249-39

A-5.2.1.

A-5.2.1. Single Storey Wet Venting

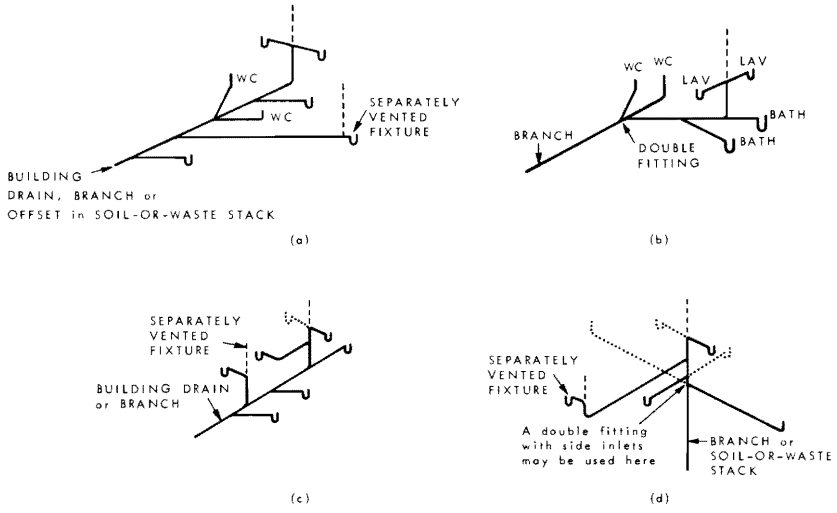

BR 5563-3

Each section of a single storey wet vent is sized according to the total load it serves (see Article 5.8.1.). Separately vented fixtures may connect to a wet vent.

Fixture drains are connected separately and directly into the branch or soil-or-waste stack in conformance with Article 5.6.3.

Figure (d) shows that water closets are connected downstream of all other fixtures when connected to a vertical pipe.

A-5.2.2.(1), (2) and (3) Single Storey Wet Venting with Circuit Vents

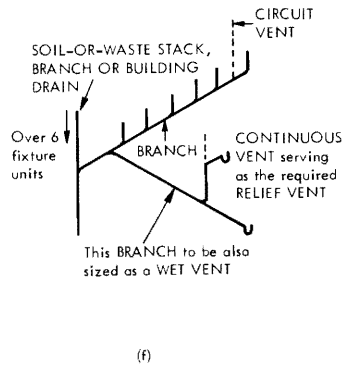
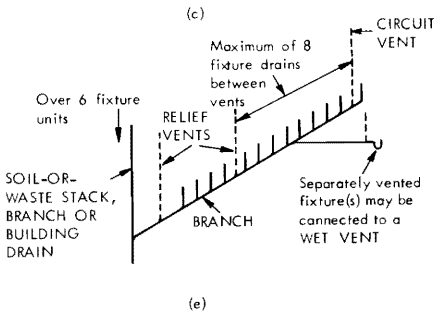
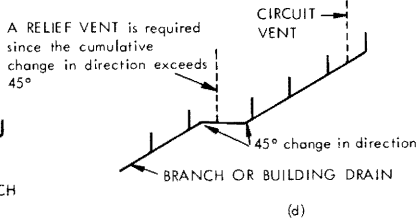
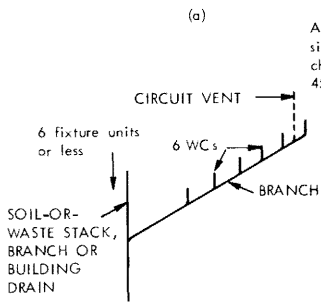
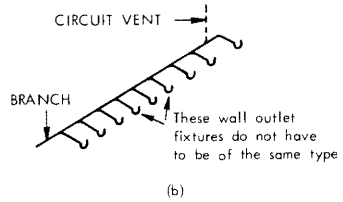
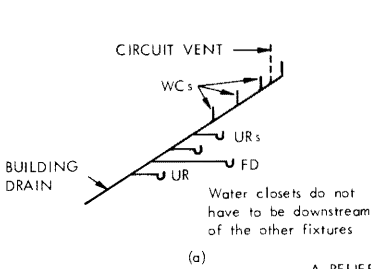

BR 5249-41

A-5.2.2.

A-5.2.2.(4) Single Storey Wet Venting with Combined Relief Vents

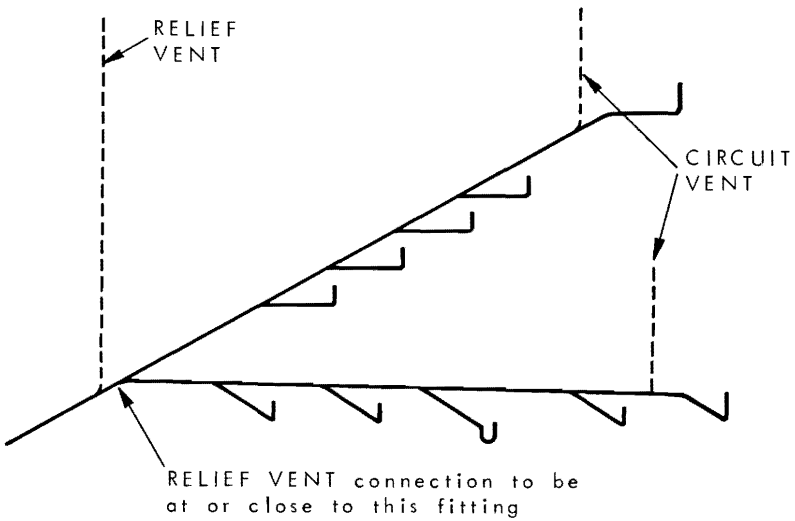
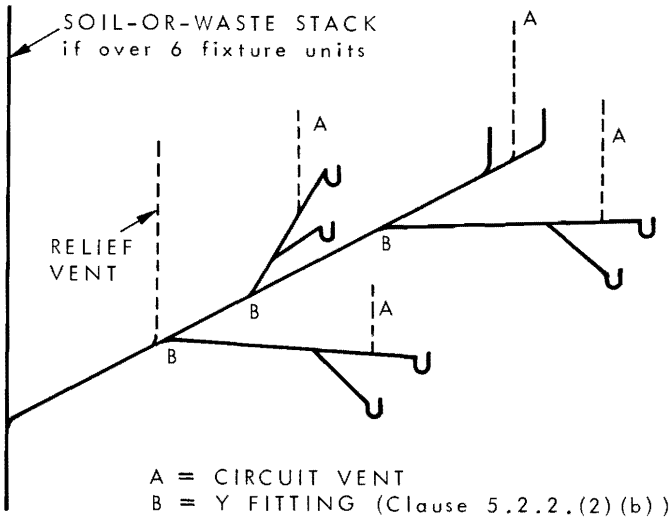

BR 5563-4

A-5.4.1. Stack Vents

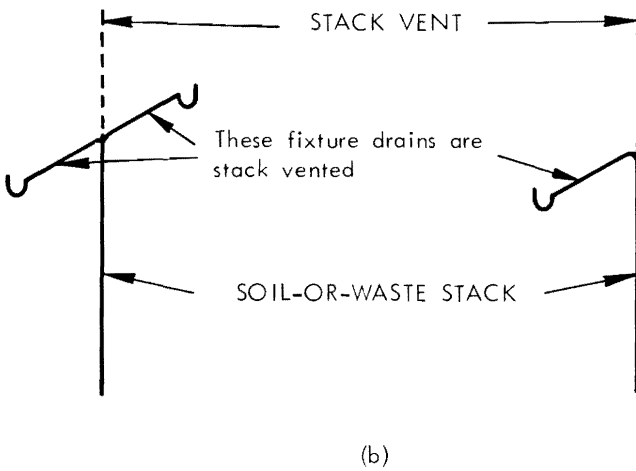
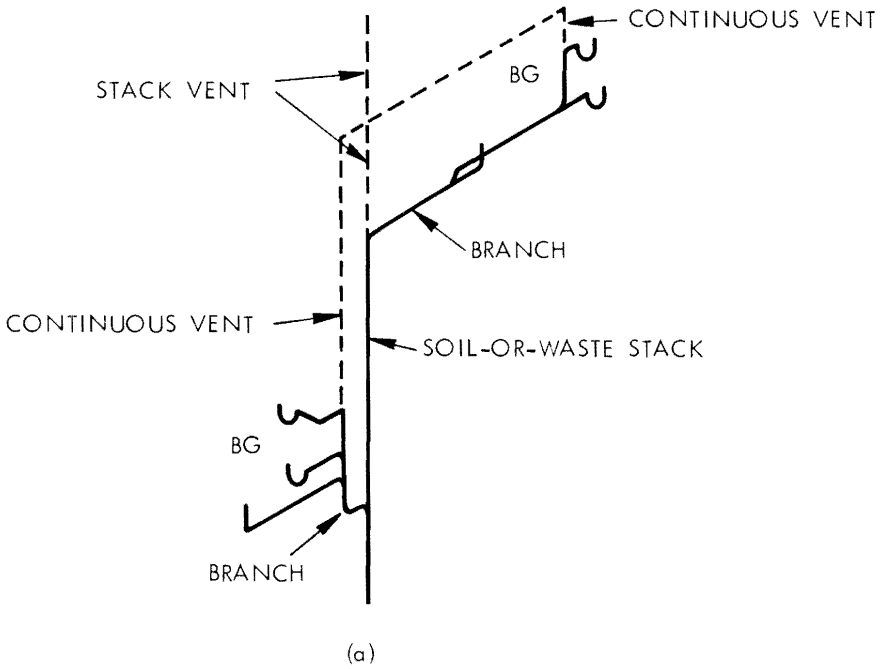

A-5.4.2.

A-5.4.2. Vent Stacks

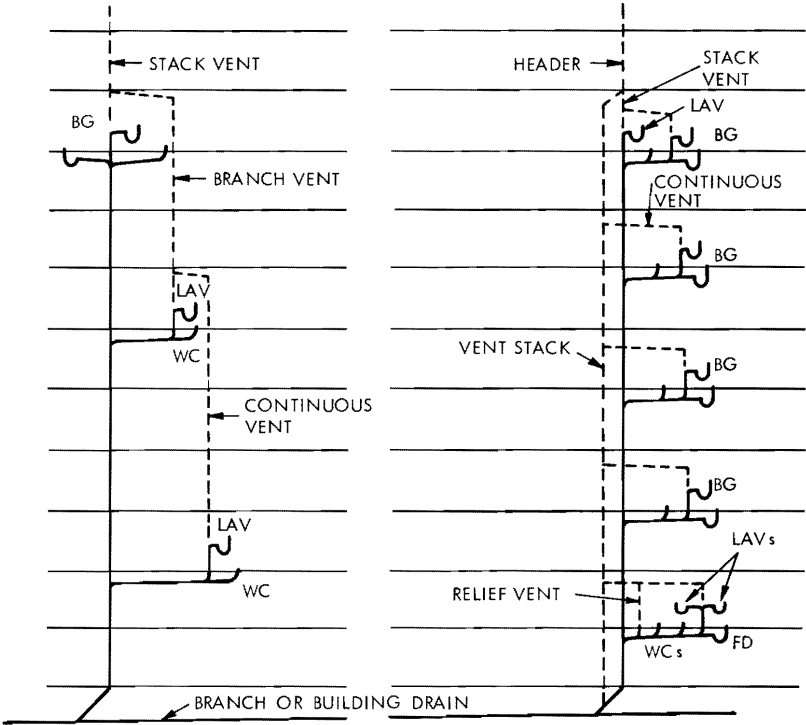

No vent stack required.
 (Fixtures draining to the soil-or-waste stack from 3 storeys only)

Vent stack required.
 (Fixtures draining to the soil-or-waste stack from more than 4 storeys)

BR 5249-43

Vent stack may terminate at the lowest soil-or-waste connection or immediately below it or it may terminate at the junction of soil-or-waste stack and branch or building drain. The vent stack may also be connected at its lower end to the soil-or-waste stack below the lowest soil-or-waste pipe connection.

A-5.4.4. Relief Vents for Offsets

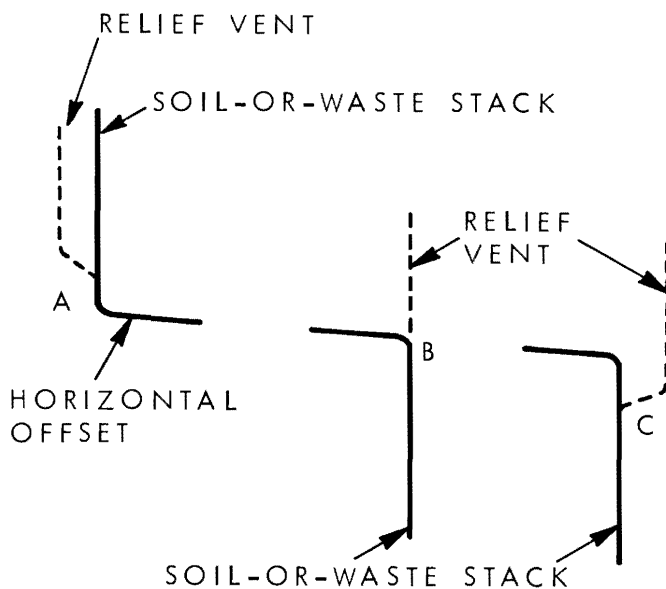

BR 5563-5

When an offset is greater than 1.5 m, it must be sized as a branch or building drain (see Sentence 4.10.6.(2)). A relief vent is required at A, B or C.

A-5.6.2.

A-5.6.2.(2) Vent Pipe Connections

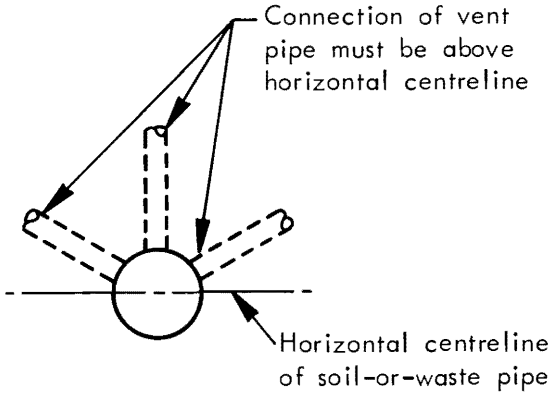

BR 5249-44

Fittings used to connect vent pipes to nominally horizontal soil-or-waste pipes are specified in Subsection 2.4.

A-5.6.3.(1) Vent Connections

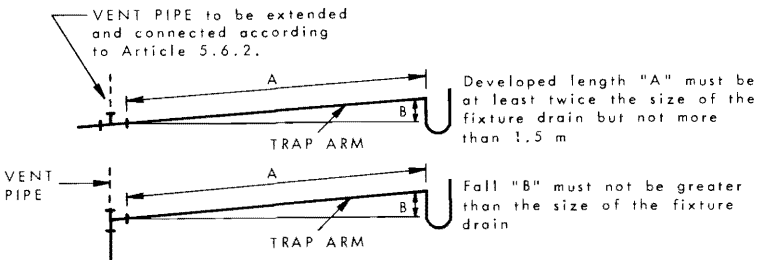

BR 5563-6

A-5.6.3.(1)(c) and A-5.6.3.(2) Location of Vent Pipes

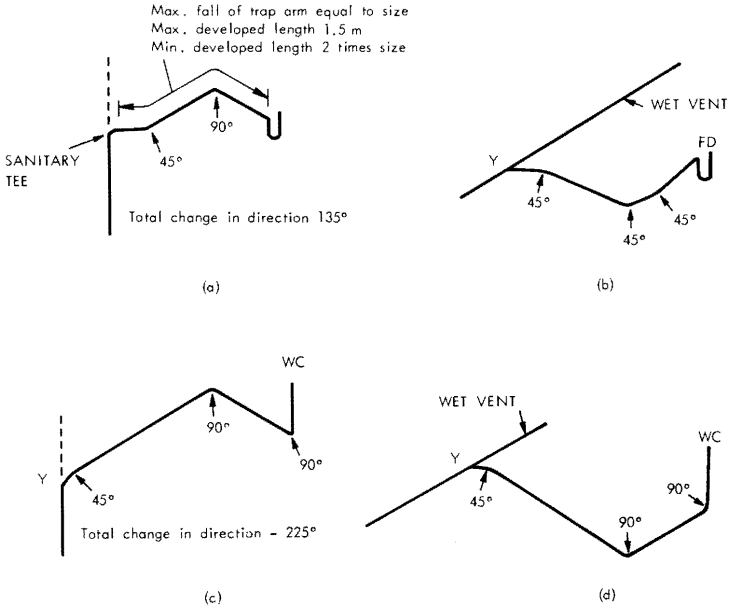

BR 5249-46

A-5.6.3.(3) Length of WC Fixture Drain

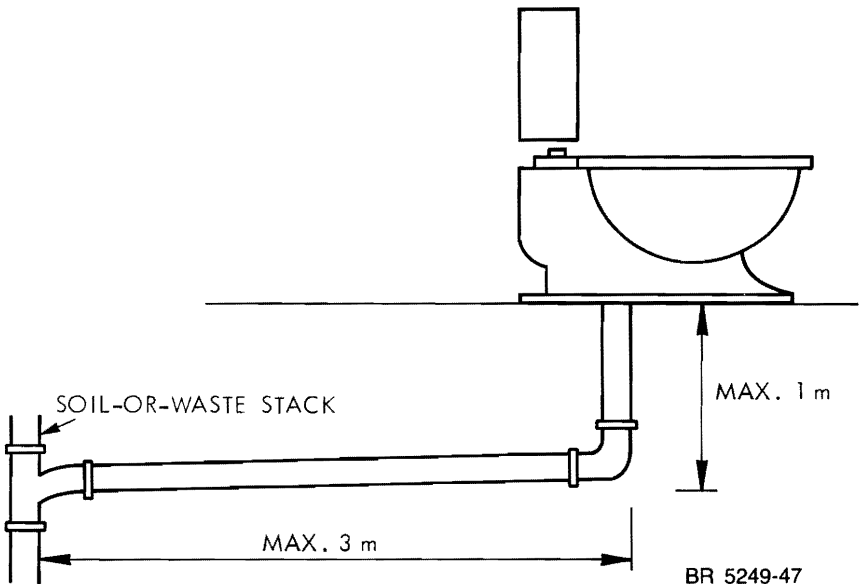

BR 5249-47

A-5.6.5.

A-5.6.5.(3) Vent Terminals

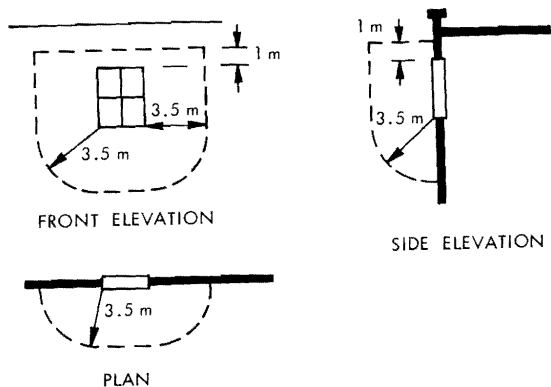

(a)

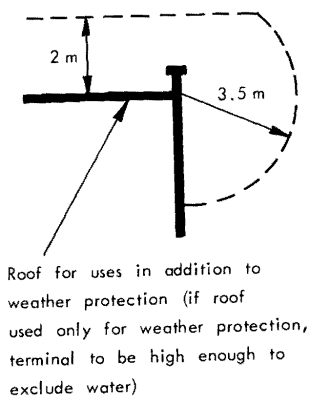

(b)

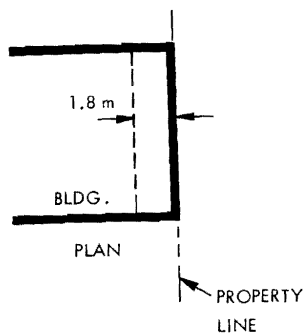

(c)

BR 5249-48

No vent pipe other than a fresh air inlet may terminate within the limits indicated.

A-5.8 Sizing of Building Venting Systems

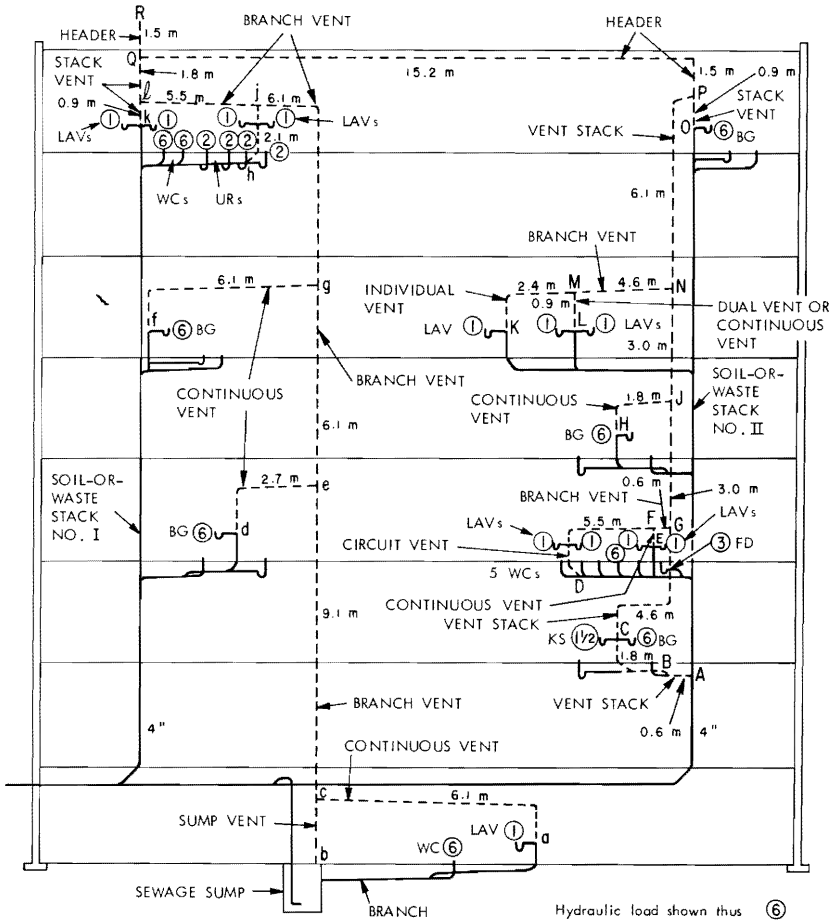

BR 5249-49

A-5.8 (Cont'd) Table of Vent Pipe Sizes

| Vent Pipe | Developed Length Used to Determine Size, m | Hydraulic Load Used to Determine Size, fixture units | Code Reference to be Considered | | Minimum Size, in. |
|-------------------------------|--|--|-------------------------------------|-------------------------------------|-------------------|
| Continuous vent (ac) | 32.9 (acegjl) | 7 | 5.7.1. 5.8.2.(1) | 5.8.2.(2) | 2 |
| Sump vent (bc) | N/A | 7 | 5.7.6. | | 2½ |
| Branch vent (ce) | 32.9 (acegjl) | 7 | 5.7.1. 5.7.2. | 5.8.2.(1) 5.8.2.(4) | 2½ |
| Continuous vent (de) | 20.4 (degjl) | 6 | 5.7.1. 5.8.2.(1) | 5.8.2.(2) | 1½ |
| Branch vent (eg) | 32.9 (acegjl) | 13 | 5.7.1. 5.7.2. | 5.8.2.(1) 5.8.2.(4) | 2½ |
| Continuous vent (fg) | 17.7 (fgjl) | 6 | 5.7.1. 5.8.2.(1) | 5.8.2.(2) | 1½ |
| Branch vent (gj) | 32.9 (acegjl) | 19 | 5.7.1. 5.7.2. | 5.8.2.(1) 5.8.2.(4) | 2½ |
| Circuit vent (hj) | 7.6 (hjl) | 22 | 4.2.1.(1)(e) 5.7.1. 5.8.1. | 5.8.2.(1) 5.8.2.(3) | 1½ |
| Branch vent (jl) | 32.9 (acegjl) | 41 | 5.7.1. 5.8.2.(1) | 5.8.2.(4) | 3 |
| Stack vent (kl) | 4.2 (klQR) | 36 | 5.7.1. 5.8.3.(1) | 5.8.3.(2) | 2 |
| Stack vent (lQ) | 4.2 (klQR) | 43 | 5.7.1. 5.7.2. | 5.8.3.(1) 5.8.3.(2) | 3 |
| Vent Stack Section (ABCGJNPQ) | 37.3(ABCGJNPQR) | 59½ | 4.2.1.(1)(g) 4.9.1. 5.7.1. | 5.8.1.(1) 5.8.3.(1) 5.8.3.(2) | 3 |
| Circuit vent (DF) | 6.1 (DFG) | 32 | 4.2.1.(1)(e) 5.7.1. 5.8.1.(1) | 5.8.2.(1) 5.8.2.(3) | 1½ |
| Continuous vent (EF) | N/A | 34 | 4.2.1.(1)(c) 5.2.2.(3) | 5.7.1. 5.7.3. | 1½ |
| Column I | 2 | 3 | 4 | | 5 |

A-5.8 (Cont'd) Table of Vent Pipe Sizes

| Vent Pipe | Developed Length Used to Determine Size, m | Hydraulic Load Used to Determine Size, fixture units | Code Reference to be Considered | Minimum Size, in. |
|----------------------|--|--|---------------------------------|-------------------|
| Branch vent (FG) | 6.1 (DFG) | 34 | 5.7.1, 5.8.2.(1) 5.8.2.(4) | 1½ |
| Continuous vent (HJ) | 1.8 (HJ) | 6 | 5.7.1, 5.8.2.(1) 5.8.2.(2) | 1½ |
| Individual vent (KM) | N/A | 1 | 5.7.1. | 1¼ |
| Dual vent (LM) | N/A | 2 | 5.7.1. | 1¼ |
| Branch vent (MN) | 7.0 (KMN) | 3 | 5.7.1, 5.8.2.(1) 5.8.2.(4) | 1¼ |
| Stack vent (OP) | 19.1 (OPQR) | 59½ | 5.7.1, 5.8.3.(1) 5.8.3.(2) | 2½ |
| Header (PQ) | 37.3(ABCGJNPQR) | 59½ | 5.7.1, 5.8.2.(1) 5.8.2.(5) | 3 |
| Header (QR) | 37.3(ABCGJNPQR) | 102½ | 5.7.1, 5.8.2.(1) 5.8.2.(5) | 4 |
| Column 1 | 2 | 3 | 4 | 5 |

A-5.8.1.(1) Sizing of Single Storey Wet Vent Systems

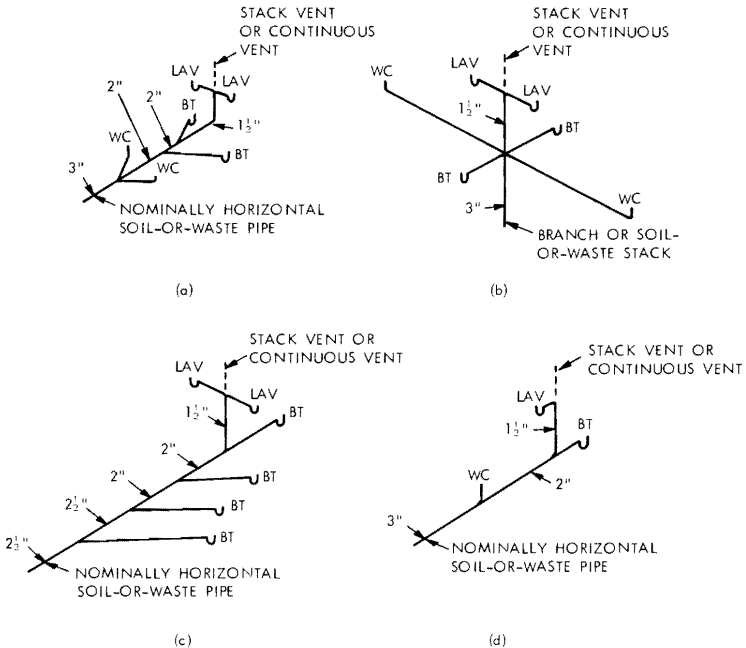

BR 5249-50

A-5.8.1.

A-5.8.1.(2) Sizing of Multi-Storey Wet Vent Systems

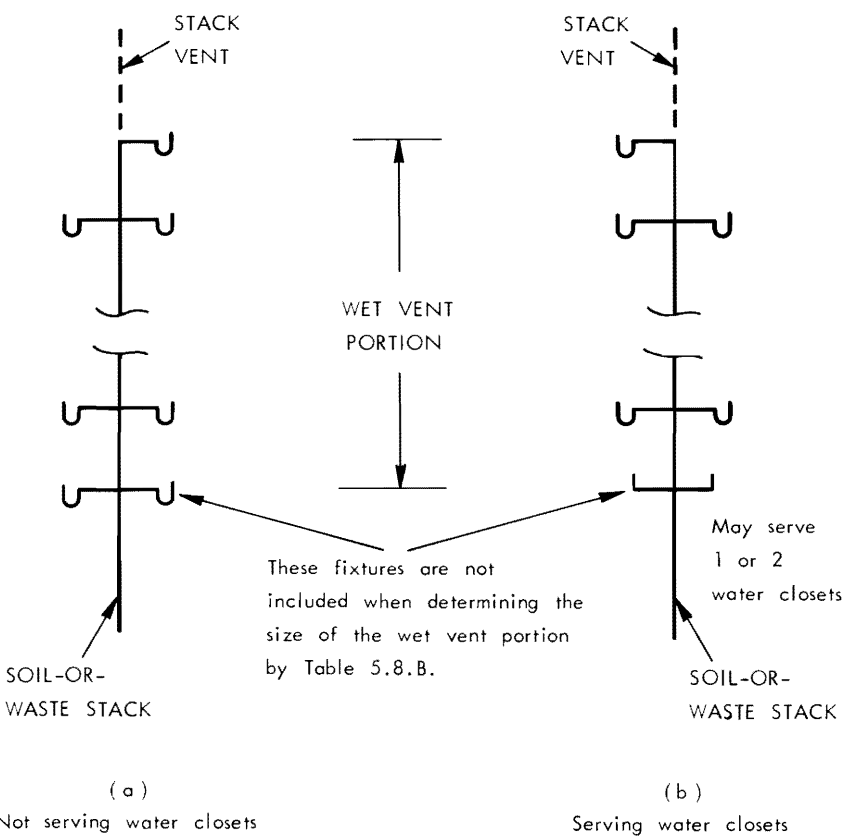

BR 5563-10

A-5.8.2. and 5.8.3. Lengths to be Considered When Sizing Vent Pipes

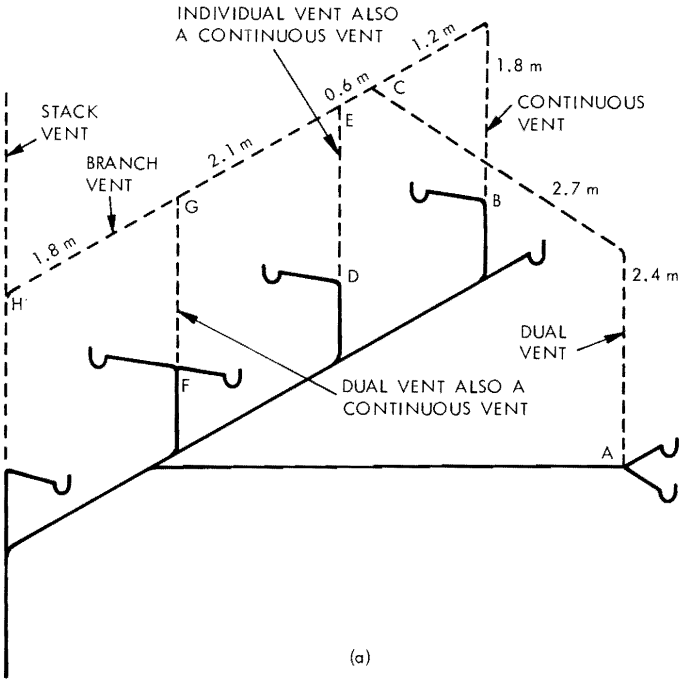

| VENT | LENGTH TO BE CONSIDERED | REFERENCE |
|--------------------|---|-----------|
| Dual vent AC | N/A | 5.8.2.(1) |
| Continuous vent BC | BCEGH $1.8 + 1.2 + 0.6 + 2.1 + 1.8 = (7.5)$ | 5.8.2.(2) |
| Individual vent DE | N/A | 5.8.2.(1) |
| Dual vent FG | N/A | 5.8.2.(1) |
| Branch vent CEGH | ACEGH $2.4 + 2.7 + 0.6 + 2.1 + 1.8 = (9.6)$ | 5.8.2.(4) |

BR 5249-51

A-5.8.3.

A-5.8.2. and 5.8.3. (Cont'd)

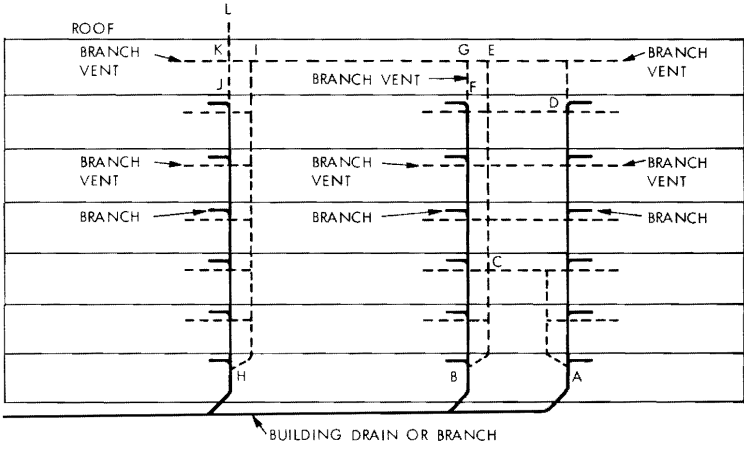

(b)

| VENT PIPE | LENGTH TO BE CONSIDERED | REFERENCE |
|---|-------------------------|-----------|
| Vent stack (AC) | ACEGIKL | 5.8.3.(2) |
| Vent stack (BC) | BCEGIKL | 5.8.3.(2) |
| Vent stack (HI) | HIKL | 5.8.3.(2) |
| Stack vent (DE) | DEGIKL | 5.8.3.(2) |
| Stack vent (FG) | FGIKL | 5.8.3.(2) |
| Stack vent (JK) | JKL | 5.8.3.(2) |
| Header (CEGIKL) (or any section of it) | ACEGIKL | 5.8.2.(5) |

BR 5249-52

A-6.1.1.(1) Potable Water Systems. The design procedures contained in Chapter 35 of the ASHRAE Guide and Data Book 1970, in Chapter 37 of the ASHRAE Handbook, 1976 Systems, in ASPE 1975-76, Data Book, Volume I, Basic Plumbing Design and in ASPE 1977-78, Data Book, Volume II, Special Plumbing Systems Design are considered good engineering practice in the field of potable water systems.

A-6.1.13. Water Hammer Prevention. Water hammer is a build up of pressure in a length of horizontal or vertical pipe which occurs when a valve or faucet is closed suddenly. The longer the pipe and the greater the water velocity the greater is the pressure exerted on the pipe, which can be many times the normal static water pressure and be sufficient to burst the pipe. Ordinary kitchen and bathroom faucets can be closed quickly enough to cause water hammer even with relatively low water pressure in the pipe.

Means of preventing water hammer should be installed wherever there are valves or faucets, particularly where they are at the end of long lengths of pipes. This may be done by installing either water hammer arresters which are manufactured for the purpose or air chambers installed vertically that are fabricated from pieces of piping with a closed upper end and connected to the end of the horizontal or vertical run of pipe.

The air chamber should be 300 to 450 mm long if made from the same size pipe as the water pipe it serves. If the chamber is made from a pipe with larger diameter than the water pipe, its length can be reduced accordingly.

Air chambers should be accessible if they are the manufactured type with top air valve and a stop-and-waste valve or are of the diaphragm type. If made from piping, air chambers may become ineffective because of waterlogging, in which case provision should be made to drain that portion of the system. During the drainage operation fresh air is introduced into the chamber through the open faucet. After such draining, the valve or faucet should be closed before refilling the system with water, to ensure that the air chamber contains the maximum amount of air under pressure.

A-6.2.1. Examples of equipment to which these requirements apply are residential or industrial space heating boilers to which chemicals may be added, or a sprinkler system to which antifreeze may be added. To be effective, every device installed in a potable water system for protection against backflow must be maintained in good working condition. See explanation for definition for backflow preventer and for back-siphonage preventer (vacuum breaker).

A-6.2.3.

A-6.2.3.(1) Installation of Air Gaps and Back-Siphonage Preventers

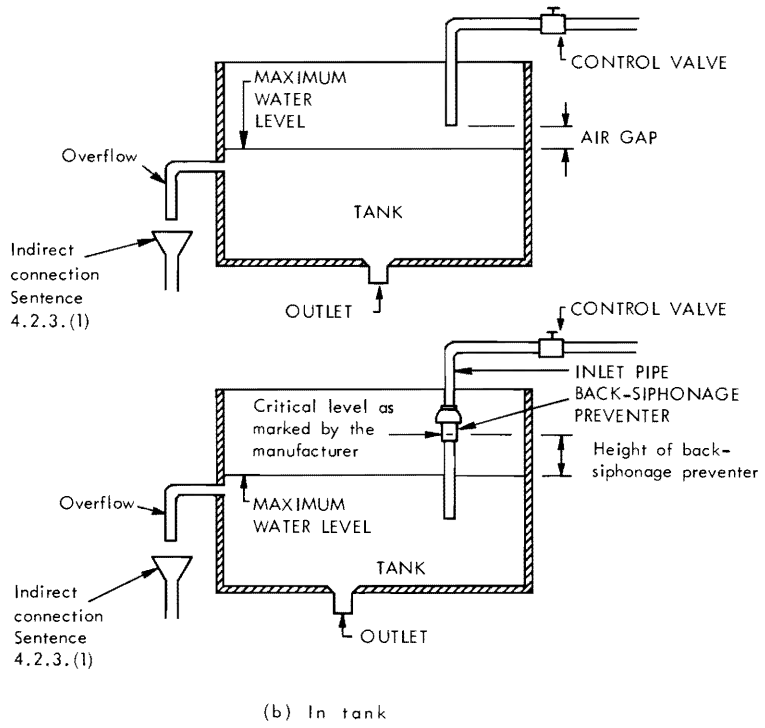
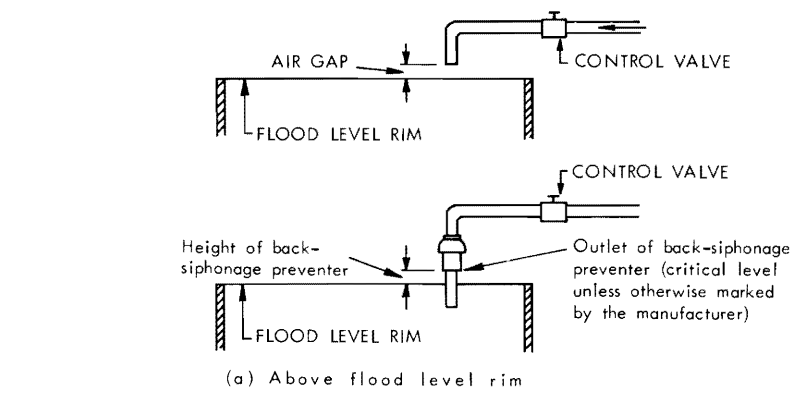

BR 5249-54

A-6.3. This Subsection contains performance requirements for water systems. Two widely used references for the design of water systems are:

Water-Distributing Systems for Buildings by R. B. Hunter, Building Materials and Structures Report BMS 79, United States Department of Commerce, National Bureau of Standards, Washington, D.C., 1941, and

National Plumbing Code Handbook edited by V. T. Manas, McGraw-Hill Book Company, New York, U.S.A. 1957.

A-7.3.2. Outlets from Non-Potable Water Systems. The location of outlets from non-potable water systems where they can be discharged into a sink or lavatory, a fixture into which an outlet from a potable water system is discharged, or a fixture that is used for a purpose related to the preparation, handling or dispensing of food, drink or products that are intended for human consumption, may have proved to have been acceptable on the basis of past performance in some localities, and its acceptance under Article 1.4.3. of this Code may be warranted.

INDEX

A

- Abbreviations of
 - organizations and authorities, 1.3.3.
 - words and phrases, 1.3.4.
- Acrylonitrile-butadiene-styrene (ABS) pipe, 2.5.9., 2.5.10., 3.4.5.(2)(e), 3.4.5.(3)
- Administration, 1.1.2., 1.8
- Air breaks, 1.3.2., 3.3.11., 4.2.3.
- Air gaps, 1.3.2., 6.2.3.
- Air tests, 3.6.1.(1), 3.6.5., 3.7.1.
- Ancillary buildings, 1.6.4.
- Application of Code, 1.1
- Asbestos-cement pipe and fittings, 2.5.1., 2.5.2., 3.4.5.(2)(d), 3.5.2.
- Aspirators, 6.2.1.(6)

B

- Backfill for piping, 3.5.1.
- Backflow
 - definition, 1.3.2.
 - preventers, 1.3.2., 6.2.5.
 - protection from, 4.6.4.(2), 6.2.1.(3)
- Back-siphonage
 - definition, 1.3.2.
 - preventers, 1.3.2., 2.9.9., 6.2.3., 6.2.4.
 - prevention, 6.2
- Backwater valves, 1.3.2., 4.6.4.
- Ball tests, 3.6.1.(5), 3.6.2.(2), 3.6.7.
- Branches
 - definition, 1.3.2.
 - hydraulic load on, 4.10.7.
 - servicing water closets, 4.9.2.(2)
- Branch vents, 1.3.2., 5.6.4.(2), 5.7.2., 5.8.2.(1), 5.8.2.(4)
- Brass floor flanges, 2.9.1.
- Brass pipe, 2.7.1.(2), 3.4.5.(1)(g)
- Brass pipe flanges and fittings, 2.7.2., 2.7.3.
- Bronze pipe flanges and fittings, 2.7.2., 2.7.3.
- Building drains
 - cleanout for, 4.7.1.(6)
 - combined, 4.6.1.(2)
 - definition, 1.3.2.
 - hydraulic load on, 4.10.8., 4.10.9.
 - on drawings for plumbing permit, 1.8.1.(1)
 - protection of, from backflow, 4.6.4.(2), 4.6.4.(5)
 - protection of, from damage, 3.5
 - sanitary, 4.10.8.
 - size of, 4.9.2.(2), 4.10.D., 4.10.E.
 - storm, 4.10.9.
- Building sewers
 - cleanouts for, 4.7

- combined, 4.5.2.(1), 4.10.9.
 - definition, 1.3.2.
 - developed length of, 4.7.2.(3) and (4)
 - hydraulic load on, 4.10.8., 4.10.9.
 - sanitary, 4.7, 4.10.8.
 - size of, 4.10.D., 4.10.E.
 - slope of, 4.10.D., 4.10.E.
 - storm, 4.7, 4.10.9.
- Building traps, 2.3, 4.5
 - cleanout for, 4.5.4.
 - definition, 1.3.2.
 - fresh air inlets for, 5.5.3.
 - location of, 4.5.4.
 - Burned lead joints, 3.2.8., 3.3.5.

C

- Cast-iron soil pipe and fittings, 2.6.1., 2.6.2., 3.3.2., 3.4.5.(2)(c)
- Cast-iron water pipe and fittings, 2.6.4., 2.6.5., 3.4.5.(2)(c)
- Caulked lead drainage joints, 3.2.1.
- Caulking compounds, cold, 2.8.2., 3.2.10.
- Caulking lead, 2.8.3.(1)
- Cement jointing mortar, 2.8.1.
- Cement joints, 3.2.7.
- Cement-mortar pipe lining, 2.6.4.(2)
- Check valves, 1.3.2., 4.2.1.(1)(a), 4.6.3.(6)
- Chlorinated poly (vinyl chloride) (CPVC) pipe and fittings, 2.5.7.
- Circuit vents, 1.3.2., 4.2.1.(1)(e), 5.2.2., 5.6.4., 5.7.3., 5.8.2.
- Cleaning of water systems, 6.2.2.
- Cleanout,
 - definition, 1.3.2.
 - fittings, 2.9.3.(2), 4.7.1.(2)
 - for traps, 4.5.4., 4.7.1.(2), 4.7.4.(3)
 - installation of, 4.7
 - location of, 4.7.1., 4.7.4.
 - manhole as, 4.7.3.
 - rodding of, 4.7.A., 4.7.2.(5), 4.7.4.(1)
 - size and spacing of, 4.7.2.
- Clear water waste, 1.3.2.
- Climatic data, 4.10.4.(1)
- Cold caulked joints, 3.2.10.
- Combined building drains
 - definition, 1.3.2.
 - restricted use of, 1.6.1.(2), 4.6.1.(2)
- Combined building sewers, 1.3.2., 4.5.2.(1), 4.10.9.
- Combined sewer, 1.3.2.
- Combined temperature and pressure relief valves, 2.9.10.

Combustible
definition, 1.3.2.
piping, 2.5.10.(2)
Compounds, caulking and sealing, 2.8
Concrete pipe and fittings, 2.5.3.
Connections
direct, 4.2.1.(1), 4.2.3.
fixture, 4.2.1.
indirect, 4.2.1.(1)(a) and (d)
running thread and packing nut,
3.3.3.(1)
service, 1.6
to drainage systems, 4.2, 4.3.4.
to lead bend, 4.2.1.(3)
to nominally horizontal offset, 4.2.1.(2)
to nominally horizontal soil-or-waste
pipe, 4.2.1.(2)
to a vent stack, 4.2.1.(1)(g)
trap, 2.3.1.(2)
Continuous vents, 1.3.2., 5.2.1.(1),
5.2.2.(3), 5.8.2.(1) and (2)
Cooling of hot waste, 4.4.2.
Copper pipe, 2.7.1.(1), 3.4.5.(2)(g)
Copper tube, 2.7.4., 3.3.10., 3.4.5.(2)(g)
Corrugated steel pipe and coupling,
2.6.8.
Couplings, mechanical pipe, 2.9.4.
CPVC (see Chlorinated poly (vinyl
chloride) pipe)
Cross fittings, 2.4.1.(2)

D

Dead ends in piping, 4.6.1.(3)
Definitions, 1.3
Developed length
definition, 1.3.2.
of fixture outlet pipes, 4.8.2.
of trap arm for vent pipes, 5.6.3.(1)
Direct flush valves, 2.9.7.
Dissimilar materials, joints for, 3.3.6.
Documents, referenced, 1.9
Downspouts (see Leaders)
Drains (see Building drains, Fixture
drains, Roof drains)
Drawings, 1.8
Drainage equipment, 4.6.3.
Drainage joint, caulked lead, 3.2.1.
Drainage of piping, 6.1.2.
Drainage piping, 2.6.1.
arrangement of, 4.6
hydraulic loads on, 4.10
location of, 4.6.2.
minimum slope and length of, 4.8
sizing of, 4.9
Drainage systems, 4

arrangement of piping, 4.6
cleanouts, 4.7
connections to, 4.2, 4.3.4.
definition, 1.3.2.
hydraulic loads, 4.10
location of fixtures, 4.3
minimum slope and length of pipes,
4.8
sanitary, 4.4.1., 4.7.1.(1)
size of pipes, 4.9
storm, 4.2.1.(1), 4.5.2., 4.7.1.(1),
4.10.9.
testing of, 3.6
traps, 4.5
treatment of sewage and wastes, 4.4
Drawings and related documents, 1.8
Drilled and tapped joints, 3.3.1.
Drinking fountains, 4.2.1.(1)(a)
Drinking fountain bubblers, 2.9.8.
Dual vents, 1.3.2., 5.6.4., 5.8.2.(1)

E

Eavestroughs (see Gutters, roof)
Ejectors, 4.6.3.(7), 6.2.1.(5)
Electrical insulation at piping supports,
3.4.3.
Enamelled fixtures, 2.2.2.
Equivalents, 1.4
Expansion and contraction, piping
system, 3.3.9.

F

Ferrous pipe and fittings, 2.6
Final tests, 3.6.1.(2), 3.6.1.(4), 3.6.2.(1),
3.6.6.(1)
Fittings, 2.4–2.7
brass or bronze, 2.7.2., 2.7.3.
butt-fusion, 2.5.5.(4)
cast-iron, 2.6.5.
concrete, 2.5.3.(4)
CPVC hot and cold water pipe, 2.5.7.
cross, 2.4.1.(2)
ferrous, 2.6
flared joint, 2.7.7.
installation of pipe, 3.2.1.(4)
insert, 2.5.5.(3)
lead, 2.7.8.(1)
malleable iron, 2.6.6.
marking of, 2.1.4.
non-ferrous, 2.7
non-metallic, 2.5
on drawings for plumbing permit,
1.8.1.(1)

- plastic, 2.5.9., 2.5.10.
- polybutylene, 2.5.8.
- restrictions on use of, 2.4, 2.5.3.(4), 2.5.4.(3)
- screwed, 2.6.5., 2.6.6.
- single or double sanitary T, 2.4.2.
- sisson, 2.4.4.
- solder-joint, 2.7.5., 2.7.6.
- supply and waste, 2.9.6.
- T, 2.4.1.(1)
- vitriified clay, 2.5.4.
- Fixtures, 2.2**
 - connections of, 4.2.1., 4.2.2., 4.2.3., 5.5.4., 5.6.4.
 - construction of, 2.2
 - definition, 1.3.2.
 - enamelled, 2.2.2.(3) and (4)
 - future installation of, 5.5.4.
 - hydraulic load from, 4.9.A., 4.10 indirectly connected, 3.3.11., 4.2.1.(1)(d), 4.5.1.(4)
 - installation of, 1.7.1., 3.4.1., 4.3.1., 6.1.7.
 - location of, 1.7.1., 1.7.2., 4.3
 - plastic, 2.2.2.(6)
 - specifications for, 2.2
 - stainless steel, 2.2.2.(5)
 - used, 2.1.3.
 - vitreous, 2.2.2.(2)
- Fixture drains**
 - cleanouts for, 4.7.1.(9)
 - connections of, to wet vents, 5.2.2., 5.3.1.
 - definition, 1.3.2.
 - fixture traps for, 5.6.3.(1) and (2)
 - for floor outlet fixtures, 3.3.8.(1)
 - minimum slope of, 4.8.1.
 - protection of, from backflow, 4.6.4.(2)
 - size of, 4.10.D., 4.10.E.
 - venting of traps for, 5.1.1.
- Fixture outlet pipes**
 - definition, 1.3.2.
 - developed length of, 4.8.2.
 - for indirectly connected fixtures, 4.2.3.(2)
 - size of, 4.9.3.
- Fixture units**
 - conversion to litres, 4.10.5.
 - definition, 1.3.2.
- Flanges**
 - floor, 2.9.1., 3.3.8.
 - water closet, 2.9.2.(1)
- Flared joints, 3.2.5.**
- Flared joint fittings, 2.7.7.**
- Flashing, vent pipe, 2.9.11.**

- Floor drains**
 - connections of, to drainage systems, 4.3.4., 4.5.2.(2)
 - traps for, 4.5.2.(2), 5.1.1.(2)
- Floor outlet fixtures, drain connections, 3.3.8.**
- Flow control roof drain, 1.3.2., 4.10.4.(2)**
- Flushing devices, 2.9.7., 6.1.11.**
- Freezing, protection from, 3.5.4.**
- Fresh air inlets, 1.3.2., 5.5.3.**

G

- Galvanized steel pipe, 2.6.7.**
- Garbage grinders, 4.3.3.**
- Grease interceptors (see Interceptors)**
- Groove and shoulder mechanical pipe couplings, 2.9.4.**
- Gutters, roof, 4.10.10.**

H

- Hangers, pipe, 3.4.3., 3.4.5.(4) and (5)**
- Headers, 1.3.2., 5.8.2.(1), 5.8.2.(5)**
- Horizontal offsets (see Offsets in piping)**
- Horizontal piping, support of, 3.4.5.**
- Hot poured joints, 3.2.6.**
- Hub and spigot pipe, 3.2.1.(4)**
- Hydrant, frostproof, 6.1.9.**
- Hydraulic loads, determination of, 4.10**

I

- Increaser fittings, 3.3.4.**
- Indirect connections, 3.3.11., 4.2.1.(1)(d), 4.3.2.**
- Individual vents, 1.3.2., 5.6.4.(1), 5.8.2.(1)**
- Inlets, fresh air, 5.5.3.**
- Installation of fixtures, 1.7.1., 3.4.1., 4.3.1., 6.1.7.**
- Insulation, electrical at piping supports, 3.4.3.**
- Interceptors**
 - capacity of, 4.4.3.(4)
 - cleanouts for, 4.7.1.(9)
 - definition, 1.3.2.
 - design of, 2.3.2.
 - drum trap for, 2.3.1.(4)
 - gasoline, 4.4.3.(2)
 - grease, 4.4.3.(1)
 - oil, 4.4.3.(2)
 - replacing traps, 4.5.1.(5)
 - restricted use of, 4.3.3.
 - venting of, 5.5.2.
 - where required, 4.4.3.(1) to (3)

J

Jointing materials, 2.8
Joints, pipe, 3.2 and 3.3

L

Lead
caulking, 2.8.3.(1)
waste pipe and fittings, 2.7.8.,
3.4.5.(2)(b)
Leaders (downspouts)
connections of, to roof drain, 3.3.7.
definition, 1.3.2.
hydraulic load on, 4.10.11.
sheet metal, 2.6.9.
trap for, 4.5.2.(1) and (2)
Lighting of rooms, 1.7.1.(1)
Loads, hydraulic, 4.10

M

Malleable iron water fittings, screwed,
2.6.6.
Manholes, as cleanouts, 4.7.2.(2), 4.7.3.
Marking of pipes and fittings, 2.1.4.,
2.1.5., 7.2.1.
Materials and equipment
defects in, 2.1.1.
equivalents, 1.4.1.
exposure of, 2.1.2.
for fittings, 2.4–2.7
for fixtures, 2.2
for traps and interceptors, 2.3
jointing, 2.8
marking of, 2.1.4., 7.2.1.
miscellaneous, 2.9
used, 2.1.3.
Mechanical joints, 3.2.9.
pipe couplings for, 2.9.4.
Mobile home
sewer service, 4.6.5.(1)
water service pipe for, 6.1.14.
Mortar, cement jointing, 2.8.1.
Multi-storey wet venting, 5.3

N

Nominally horizontal
definition, 1.3.2.
piping, 3.4.5.
Nominally vertical, 1.3.2.
Noncombustible piping
definition, 1.3.2.
piping, 2.5.10.(3)
Non-ferrous pipe and fittings, 2.7
Non-metallic pipe and fittings, 2.5
Non-potable water systems, 7
connections of, to potable water
systems, 6.2, 7.1.1.

identification of, 7.2.1.
location of pipes and outlets for,
7.3.1., 7.3.2.

O

Offsets in piping, 1.3.2., 4.2.1.(2)
Oil interceptors (see Interceptors)
Outlets from non-potable water system,
7.3.2.
Overflows
rainwater tank, 4.2.2.
sink, 2.2.4.

P

Paved surfaces, hydraulic load from,
4.10.4.
Permits, plumbing, 1.8.1.
Pipe
acrylonitrile-butadiene-styrene (ABS)
2.5.9., 2.5.10., 3.4.5.(2)(e),
3.4.5.(3)
applications, summary of, 2.5, 2.7
asbestos-cement, 2.5.1., 2.5.2.,
3.4.5.(2)(d), 3.5.2.
brass, 2.7.1.(2), 2.7.2., 3.4.5.(2)(g)
cast-iron soil, 2.6.1., 2.6.2., 3.3.2.,
3.4.5.(2)(c)
cast-iron water, 2.6.4., 3.4.5.(2)(c)
chlorinated poly (vinyl chloride)
(CPVC), 2.5.7., 3.4.5.(3)
combustible, 2.5.10.(2)
concrete, 2.5.3.
copper, 2.7.1.(1), 3.4.5.(2)(g)
ductile-iron water, 2.6.4.(4)
flanges and fittings, brass or bronze,
2.7.2., 2.7.3.
hangers, 3.4.3., 3.4.5.(4)
hub and spigot, 3.2.1.(4)
joints and connections, 3.2 and 3.3
lead waste, 2.7.8., 3.4.5.(2)(b)
marking of, 2.1.4., 2.1.5., 7.2.1.
noncombustible, 2.5.10.(3)
open end, 4.6.1.(3)
plastic, 2.5.9., 2.5.10., 3.4.5.(2)(e),
3.4.5.(3), 6.1.10.
polybutylene, 2.5.8., 3.4.5.(2)(f)
polyethylene water, 2.5.5.
poly (vinyl chloride) (PVC), 2.5.6.,
3.4.5.(2)(e), 3.4.5.(3)
protection of, 3.5
sheet metal, 2.6.9.
size of, 4.9
steel, 2.6.7., 2.6.8., 3.3.2.(2),
3.4.5.(2)(a)

subsoil drainage, 4.5.3., 4.6.4.(5)
vitrified clay, 2.5.4., 3.5.2.
underground, 3.4.6., 3.5.1.
water supply, 6 and 7
welded and seamless steel, 2.6.7.

Piping
construction and use of joints, 3.2
drainage of, 6.1.2.
installation of, 3.3.9., 3.5.3.
joints and connections, 3.3
maximum pressure on, 2.1.6.
nominally horizontal, 3.4.5., 3.4.6.
protection of, 3.5
service, 1.6.4.
support of, 3.4
system, design temperature and
pressure of, 2.5.7.(2)
testing of, in drainage and venting
systems, 3.6
testing of, in potable water systems,
3.7

Plastic pipe and fittings, 2.5.9., 2.5.10.
Plumbing facilities, 1.5.1.
Polybutylene pipe and fittings, 2.5.8.
Polyethylene water pipe, 2.5.5.
Poly (vinyl chloride) (PVC) pipe and
fittings, 2.5.6., 3.4.5.(2)(e), 3.4.5.(3)

Potable water systems, 6
arrangement of piping for, 6.1
connections of, to potable and non-
potable water systems, 6.2.1., 7.1.1.
design of, 3.4.2., 6.3
layout on drawings for plumbing
permit, 1.8.1.(1)
protection of, from contamination, 6.2
size and capacity of pipes, 6.3
tanks for, 3.4.2.
testing of, 3.7

Potato peelers, 4.3.3.
Pressure reducing valves, 6.3.3.
Pressure relief valves, 2.9.10., 6.1.12.(1)
Private sewage disposal systems, 1.3.2.,
4.4.1.
Private water supply system, 1.3.2.,
6.2.1.(4)
Protection of piping, 3.5

Q

Quarter bend fittings, 2.4.3.

R

Rainfall, 4.10.4.(1)
Reducer fittings, 3.3.4.
Referenced documents, 1.9
Relief valves
discharge pipe for, 6.1.12.(6)

specifications for, 2.9.10.
where required, 6.1.12.

Relief vents
connections to, 5.2.2.(2)–(4), 5.4.4.,
5.6.4.(1)
definition, 1.3.2.
minimum size of, 5.7.3.

Risers
definition, 1.3.2.
shut-off valves for, 6.1.4.

Roof drains
connection to a leader, 3.3.7.
definition, 1.3.2.
flow control, 4.10.4.(2)

Roof gutters, 1.3.2., 4.10.10.

Roofs, hydraulic load from, 4.10.4.(1)

Rubber gasket joints, 2.6.4.(4)

S

Saddle hubs or fittings, 2.9.5.
Sanitary building drains or sewers (see
Building drains or Building sewers)
definition, 1.3.2.
Sanitary drainage systems, 1.3.2., 4.4.1.,
4.7.1.(1)
Sanitary T fittings, 2.4.2.
Scope of Code, 1.2.1.
Screwed cast-iron water fittings, 2.6.5.
Screwed joints, 3.2.3.
Screwed malleable iron water fittings,
2.6.6.
Service piping, 1.6.4.
Service water heaters, 1.3.2., 6.1.12.
Sewage treatment and disposal systems,
4.4
Sewers (see Building sewers)
Sheet lead, welds in, 3.2.8.(3)
Sheet metal leaders, 2.6.9.
Shower receptors, 2.2.3.(1)
Shut-off valves, 4.6.3.(6), 6.1.3.–6.1.8.
Single storey wet venting, 5.2
Sinks, dishwashing and food preparation,
2.2.4.
Sisson fittings, 2.4.4.
Size of
cleanouts, 4.7.2.(1)
drainage pipes, 4.9
fixture outlet pipes, 4.9.3.
vent pipes, 5.7.2.–5.7.7., 5.8
water service pipes, 6.3.4.
water supply pipes, 6.3
Slip joints, 3.3.3.(2)
Slope of drainage pipes, 4.8

Soil-or-waste pipes
 definition, 1.3.2.
 location of, 4.6.2.
 on drawing for plumbing permit,
 1.8.1.(1)
 size of, 4.9.1.

Soil-or-waste stacks
 as multi-storey wet vents, 5.3.1.
 cleanouts for, 4.7.1.(7)
 definition, 1.3.2.
 hydraulic load on, 4.10.6.
 size of, 4.9.2.(3)
 vent pipes for, 5.4

Soil pipe, cast-iron, 2.6.1., 3.3.2.,
 3.4.5.(2)(c)

Solder, wiping, 2.8.3.(1)

Soldered joint, 3.2.4.

Solder-joint fittings, 2.7.5. and 2.7.6.

S-trap standards, installation of, 3.3.8.

Stacks, hydraulic load on, 4.10.6.

Stack venting, 5.4.1.(2)

Stack vents
 definition, 1.3.2.
 requirement for, 5.4.1.(1)
 size of, 5.7.2., 5.8.3.

Steel pipe (welded and seamless), 2.6.7.

Stop-and-waste cocks, 6.1.9.

Storage type service water heaters, 1.3.2.,
 6.1.12.

Storm building drains or sewers (see
 Building drains or Building sewers)
 definition, 1.3.2.

Storm drainage systems
 connection of, 4.2.1.(1)(a)
 definition, 1.3.2.
 hydraulic load on, 4.10.9.
 sizing of, 4.10
 sumps for, 4.6.3.
 traps for, 4.5.2.

Subs, lead water closet, 3.3.8.(5)

Subsoil drainage pipes
 connection of, 4.6.4.(5)
 definition, 1.3.2.

Sumps, 4.6.3.
 venting of, 5.7.6.

Supply and waste fittings, 2.9.6.

Supports for piping, 3.4

T

T fittings, 2.4.1.(1)

Temperature limit controls, 6.1.12.(2)

Temperature relief valves
 specifications for, 2.9.10.
 where required, 6.1.12.(2)

Terminals, vent pipe, 5.6.5.

Testing of
 drainage and venting systems, 3.6
 potable water system, 3.7

Threaded cast-iron drainage fittings,
 2.6.3.

Trap arms, 1.3.2., 5.2.1.(1)(e), 5.6.3.

Trap seals
 maintaining, 4.5.5.
 size of, 2.3.1.(1)

Trap standards
 definition, 1.3.2.
 installation of, 3.3.8.

Traps
 bell, 2.3.1.(3)
 cleanouts for, 2.3.1.(2), 4.5.4.
 connections for, 2.3.1.(2)
 definition, 1.3.2.
 design of, 2.3.1.
 drum, 2.3.1.(4)
 for fixtures, 4.5.1., 4.9.A.
 for leaders, 4.5.2.(1) and (2)
 for storm drainage systems, 4.5.2.
 for subsoil drains, 4.5.3.
 interceptors used as, 4.5.1.(5)
 location of, 4.5.4.
 on drawings for plumbing permit,
 1.8.1.(1)
 restricted locations, 4.3.2.
 venting of, 5.1, 5.6.3.

Treatment of sewage and wastes, 4.4

Tube, copper, 2.7.4., 3.3.10.

U

Underground pipes
 protection of, 3.5.1. and 3.5.2.
 support of, 3.4.6.

Unions and slip joints, 3.3.3., 4.6.3.(6)

Urinals
 installation of, 3.3.8., 4.3.1.

Used materials, 2.1.3.

V

Vacuum breakers (see Back-siphonage
 preventers)
 definition, 1.3.2.

Valves
 backwater, 4.6.4.
 check, 4.2.1.(1)(a), 4.6.3.(6)
 direct flush, 2.9.7.
 gate, 4.6.4.
 pressure reducing, 6.3.3.
 pressure relief, 2.9.10., 6.1.12.(1) and
 (4)
 shut-off, 4.6.3.(6)

- tank-type water closet, 6.2.3.(3)
- temperature relief, 2.9.10, 6.1.12.(2) and (4)
- vacuum relief, 2.9.10., 6.1.12.(9)
- Ventilation of rooms, 1.7.1.(1)
- Venting
 - of floor drains, 5.1.1.(2)
 - of oil interceptors, 5.5.2.
 - of sewage sumps, 5.5.1.
 - stack, 5.4.1.(2)
 - systems, testing of, 3.6
 - wet, multi-storey, 5.3, 5.8.1.(2)
 - wet, single-storey, 5.2, 5.8.1.(1)
- Vents
 - branch, 5.6.4.(2), 5.7.2., 5.8.2.(1) and (4)
 - circuit, 5.2.2., 5.6.4., 5.7.3., 5.8.2.(1) and (3)
 - continuous, 5.2.1.(1), 5.2.2.(3), 5.6.4.(1), 5.8.2.(1)
 - dual, 5.6.4., 5.8.2.(1)
 - for manholes, 5.7.5.
 - for traps, 5.1
 - individual, 5.6.4.(1), 5.8.2.(1)
 - relief, 5.2.2.(2)–(4), 5.4.4.
 - stack, 5.4.1., 5.8.3.
 - yoke, 5.4.3., 5.7.4.
- Vent pipes
 - definition, 1.3.2.
 - arrangement of, 5.6
 - fixture connections to, 4.2.1.
 - flashing for, 2.9.11.
 - for soil-or-waste stacks, 5.4
 - for traps, 5.1
 - location of, 5.6.3.
 - minimum size of, 5.7
 - miscellaneous, 5.5
 - not required, 5.1.1.(2) and (3)
 - on drawings for plumbing permit, 1.8.1.(1)
 - sizing of, 5.8
 - support of, above roof, 3.4.7.
 - terminals of, 5.6.5.
- Vent stacks
 - definition, 1.3.2.
 - sizing of, 5.7.2., 5.8.3.
 - where required, 5.4.2.
- Vertical piping, support of, 3.4.4.
- Vitreous china fixtures, 2.2.2.(2)
- Vitrified clay pipe and fittings, 2.5.4., 3.5.2.

W

- Waste pipe, lead, 2.7.8., 3.4.5.(2)(b)
- Waste, cooling of, 4.4.2.

- Water closets, installation of, 2.9.2., 3.3.8.
- Water closet bowls, installation of, 3.4.1.(2) and (3)
- Water closet seats, 1.7.1.(2)
- Water hammer, prevention of, 6.1.13.
- Water heaters
 - indirect service, 6.1.12.
 - storage type, 6.1.12.
- Water pipe
 - asbestos-cement, 2.5.2.
 - size and capacity of, 6.3
- Water service pipe
 - for a mobile home, 6.1.14.
 - sizing of, 6.3.4.
- Water treatment device, 6.2.1.(2)
- Water supply, for fixtures, 6.3.1.
- Water systems (see Potable water systems, non-potable water systems)
- Water tests, 3.6.2.(1), 3.6.4., 3.7.1., 3.7.2., 3.7.3.
- Welded and seamless steel pipe, 2.6.7.
- Welded joints, 3.3.2.
- Welded sheet lead, 3.2.8.(3)
- Wet venting, 5.2 and 5.3, 5.8.1.
 - definition, 1.3.2.
- Wiped joint, 3.2.2.
- Wiping solder, 2.8.3.

Y

- Yoke vent
 - definition, 1.3.2.
 - minimum size of, 5.7.4.
 - where required, 5.4.3.