

**CANADIAN  
FARM BUILDING  
CODE  
1975**

**ARCHIVES**

**Issued by the  
Associate Committee on the National Building Code  
National Research Council of Canada  
Ottawa**

**Price \$5.50**

**NRCC No. 13992**

## ASSOCIATE COMMITTEE ON THE NATIONAL BUILDING CODE

C.D. Carruthers (*Chairman*)  
H.B. Dickens (*Deputy Chairman*)  
V.S. Baker  
J.G. Burchill  
S.D.C. Chutter  
R.F. DeGrace  
P. Dobush  
C.G.E. Downing  
J.T. Gregg  
W.B. Guihan  
R.V. Hebert  
J.S. Hicks  
H.T. Jones

J. Longworth  
A.T. Mann  
C.J. McConnell  
R.N. McManus  
A.T. Muir  
F.X. Perreault  
G.B. Pope  
H.R. Stenson  
R.A.W. Switzer  
J.M. Verreault  
C.J. Ward

D.W. Boyd (*Research Advisor – Meteorology*)  
R.S. Ferguson (*Research Advisor*)  
R.H. Dunn (*Secretary*)

### Retired\*

J.D. Beaty (*Deceased*)  
R.A. Bird  
W.G. Connelly  
I. Coop  
R.M. Dillon

T.R. Durley (*Deceased*)  
S.A. Gitterman  
A. Matthews  
K.R. Rybka  
D.H. Waller  
J.M. Robertson (*Secretary until  
January, 1973*)

## STANDING COMMITTEE ON FARM BUILDING STANDARDS

C.G.E. Downing (*Chairman*)  
J.R. Beale  
J.E. Brubaker  
L.A. Donoghue  
W. Hewitson  
J.J. Hogan  
H.L. Isabelle  
D.E. Kennedy  
W. Mitchell

E.B. Moysey  
L.M. Staley  
F.H. Theakston  
A. Thorimbert  
J.E. Turnbull  
J.W. White  
R.G. Winfield  
  
D.A. Lutes (*Research Advisor*)  
J.F.K. Summers (*Secretary*)

### Retired\*

J.A. Roberts

---

\*Committee term completed during preparation of 1975 Code

**CANADIAN  
FARM BUILDING  
CODE  
1975**

**Issued by the  
Associate Committee on the National Building Code  
National Research Council of Canada  
Ottawa**

**NRCC No. 13992**

First Edition 1964  
Second Edition 1965  
Third Edition 1970  
Fourth Edition 1975

©National Research Council of Canada 1975  
World Rights Reserved

Printed in Canada

## TABLE OF CONTENTS

	<b>Page</b>
<b>List of Appendices</b> .....	<b>vii</b>
<b>List of Tables</b> .....	<b>ix</b>
<b>List of Illustrations</b> .....	<b>xiii</b>
<b>Preface</b> .....	<b>xv</b>
<b>List of Abbreviations</b> .....	<b>xvii</b>
<b>Part 1 Basic Standards</b> .....	<b>1</b>
<b>Section 1.1 Design</b> .....	<b>3</b>
<b>Section 1.2 Hazards and Safety</b> .....	<b>24</b>
<b>Section 1.3 Health and Sanitation</b> .....	<b>34</b>
<b>Part 2 Good Practice and Performance</b> .....	<b>43</b>
<b>Section 2.1 Space Allowances</b> .....	<b>45</b>
<b>Section 2.2 Environmental Services</b> .....	<b>62</b>
<b>Section 2.3 Construction Practices</b> .....	<b>88</b>
<b>List of Agencies Issuing Standards and Grading Rules</b> .....	<b>96</b>
<b>Bibliography</b> .....	<b>97</b>
<b>Appendices</b> .....	<b>99</b>
<b>Index</b> .....	<b>209</b>

## LIST OF APPENDICES

	Page
Appendix A	Loads Imposed by Stored Grain, Potatoes and Silage . . . 99
Appendix B	Tables of Concrete and Mortar Mixes . . . . . 111
Appendix C	Fire-Resistance Ratings . . . . . 117
Appendix D	Water Supply . . . . . 121
Appendix E	Design Bearing Pressures . . . . . 125
Appendix F	Unit Weights of Materials . . . . . 131
Appendix G	Farm Vehicle and Equipment Storage . . . . . 137
Appendix H	January Design Temperatures (5 Per Cent Basis) . . . . 143
Appendix I	Heat and Moisture Production and Ventilation of Animals . . . . . 147
Appendix J	Heat of Respiration of Stored Products . . . . . 165
Appendix K	Ventilation . . . . . 173
Appendix L	Electrical Services . . . . . 177
Appendix M	Cladding . . . . . 189
Appendix N	Insulation Values of Building Materials . . . . . 201
Appendix O	Dimensions of Free Stalls . . . . . 205

## LIST OF TABLES

	Page
Table I	Minimum Design Floor and Suspended Loads Due to Use . . . 4
Table II	Floor Loads for Groups of Animals on Slotted Floors . . . . . 5
Table III	Species Groups for Wood . . . . . 12
Table IV	Grading Rules for Sawn Lumber . . . . . 12
Table V	Allowable Unit Stresses for
	(a) Light Framing Sizes of Sawn Lumber . . . . . 13
	(b) Joist and Plank Sizes of Sawn Lumber . . . . . 15
	(c) Structurally Graded Sawn Timber . . . . . 16
	(d) Plank Decking . . . . . 18
Table VI	Common Wire Nails, Spikes and Spiral, Square Shank Nails . . . . . 19
Table VII	Minimum Space Separations for Prevention of Radiation Fire Spread to
	(a) Adjacent Buildings having Asphalt Base Siding or Manufactured Hardboard Siding . . . . . 27
	(b) Adjacent Buildings having Wood or Plywood Siding . . . . . 27
	(c) Adjacent Buildings having Siding of Noncom- bustible, Nonreflective Material, and having No Windows or Other Openings in the Exposed Sides . . . . . 28
	(d) Adjacent Buildings having Siding of Noncom- bustible, Reflective Material, and having No Windows or Other Openings in the Exposed Sides . . . . . 28
Table VIII	Dimensions for Stanchion Tie Stalls for Dairy Cattle . . . . 46
Table IX	Litter Alley Widths between Free Stall Curbs . . . . . 46
Table X	Free Stall Dimensions for Dairy Cattle . . . . . 47
Table XI	Bedding for Dairy Cattle . . . . . 49
Table XII	Accommodations for Beef Cattle . . . . . 50
Table XIII	Accommodations for Sheep . . . . . 51
Table XIV	Accommodations for Swine . . . . . 52
Table XV	Accommodations for Horses . . . . . 53
Table XVI	Floor Housing for Laying Hens and Breeding Flocks . . . . 54
Table XVII	Requirements for the Growing of Chicken Broilers, Roasters and Replacement Pullets on Floor Systems . . . 55
Table XVIII	Requirements for the Growing of Replacement Pullets in Cage Systems . . . . . 56
Table XIX	Cumulative Feed Requirements for Growing Chickens . . . . 56

	Page
Table XX	Accommodations for Turkey Breeding Flocks . . . . . 57
Table XXI	Cumulative Feed Requirements for Growing Turkeys . . . . 57
Table XXII	Greenhouse Area Requirements per Acre of Transplanted Crop . . . . . 60
Table XXIII	Recommended Temperature and Humidity Limits for Closed Animal Production Buildings . . . . . 62
Table XXIV	Storage Life Expectancies, Recommended Storage Temperatures and Relative Humidities and the Highest Freezing Points of Fruits, Vegetables and Eggs . . . . . 63
Table XXV	Controlled Atmosphere Storage Requirements for Some Varieties of Apples . . . . . 65
Table XXVI	Daily Water Requirements of Animals . . . . . 77
Table XXVII	Manure Storage Volumes . . . . . 80
Table XXVIII	(a) Sediment Tank Capacities for Milk Centre Wastes . 81
	(b) Size of Underground Disposal Field for Milk Centre Wastes . . . . . 82
Table XXIX	Loading Rates for Aerobic Lagoons . . . . . 83
Table XXX	Loading Rates for Anaerobic Lagoons . . . . . 83
Table XXXI	(a) Loading Rates for Anaerobic Cell of Combined Anaerobic-Aerobic Lagoons Designed for a Manure Retention Period of 1 Year . . . . . 84
	(b) Loading Rates for Aerobic Cell of Combined Anaerobic-Aerobic Lagoons . . . . . 84
Table XXXII	Nitrogen, Phosphorus and Potassium Excreted by Animals Over a 365-Day Period . . . . . 85
Table XXXIII	Volume Required for Mechanically Aerated Lagoons Receiving Raw Animal Wastes . . . . . 86
Table XXXIV	BOD <sub>5</sub> Values for Manure per 1000 Pounds of Animal Live Weight . . . . . 87
Table XXXV	Maximum Exposure of Wood Roof Shingles . . . . . 91
Table A-I	Coefficients of Friction, $u'$ , for Grains at Various Moisture Contents on Various Surfaces . . . . . 105
Table A-II	Angles of Repose and Equivalent Fluid Densities for Some Grains . . . . . 107
Table B-I	Recommended Mortar Mixes . . . . . 113
Table B-II	Guide for Ordering Ready-Mixed Concrete . . . . . 114
Table B-III	Recommended Concrete Mixes for On-the-Job Mixing .. 115
Table C-I	Estimated Fire-Resistance Ratings for Frame Exterior Walls . . . . . 119
Table C-II	Estimated Fire-Resistance Ratings for Masonry Walls ... 120
Table C-III	Estimated Fire-Resistance Ratings for Floors . . . . . 120



	Page
Table D-I	Friction Head Loss in Feet of Water per 100 Feet of Steel Pipe ..... 123
Table D-II	Friction Head Loss in Feet of Water per 100 Feet of Plastic Pipe ..... 123
Table D-III	Friction Head Loss in Feet of Water per 100 Feet of Type L Copper Tubing ..... 124
Table D-IV	Friction Head Loss in Valves and Fittings ..... 124
Table E-I	Design Bearing Pressures of Soils and Rock ..... 127
Table E-II	Identification of Cohesive Soils ..... 129
Table F-I	Unit Weights of Construction Materials and Components ..... 133
Table F-II	Apparent Densities of Agricultural Materials ..... 135
Table G-I	Areas and Dimensions of Farm Vehicles and Equipment . . 139
Table I-I	Optimum Temperature Range, Heat and Moisture Production of Rabbits ..... 149
Table I-II	Heat Production of Broiler Chickens ..... 149
Table I-III	Heat Production of Shorthorn Heifers Growing at 50°F and 80°F ..... 149
Table I-IV	General Ventilation Recommendations ..... 150
Table J-I	Heat of Respiration of Vegetables ..... 167
Table J-II	Heat of Respiration of Miscellaneous Farm Products and Byproducts ..... 170
Table J-III	Heat of Respiration of Stored Fruits ..... 171
Table L-I	Copper Conductor Sizes For 2 Per Cent Drop in Potential on 110-120 Volts, 2 Conductors ..... 179
Table L-II	Allowable Ampacities for Not More Than 3 Copper Conductors in Raceway or Cable ..... 180
Table L-III	Sizes of Conductors, Fuse Ratings and Circuit Breaker Settings for Motor Overload Protection and Motor Circuit Overcurrent Protection ..... 181
Table L-IV	Maximum Allowable Ampacity of Neutral-Supported Cable Types NS-1 and NSF-2 ..... 183
Table L-V	Minimum Size of Grounding Conductor ..... 183
Table L-VI	Recommended Illumination for Farm Operations ..... 184
Table L-VII	Spacing of Cable for Floor Slab Heating Systems ..... 187
Table M-I	Plywood Wall Sheathing, Cladding and Interior Finish .. 191
Table M-II	Plywood Roof Sheathing ..... 192
Table M-III	Exterior Flakeboard Wall Sheathing, Cladding and Interior Finish ..... 193
Table M-IV	Exterior Flakeboard Roof Sheathing ..... 194
Table N-I	Insulation Value of Building Materials ..... 203
Table N-II	Typical Floor Perimeter Heat Loss Factors ..... 204

## LIST OF ILLUSTRATIONS

	Page
Figure 1-A	Lateral Pressures for Corn Silage and Dry Shelled Corn .. 108
Figure 2-A	Loads Imposed by Stored Potatoes on Bin Walls ..... 109
Figure 1-H	January Design Temperature (5 Per Cent Basis) ..... 145
Figure 1-I	Milk Production Versus Temperature ..... 151
Figure 2-I	Total and Latent Heat Production of Cattle ..... 152
Figure 3-I	Heat and Moisture Production From Growing Cattle, Winter Conditions ..... 153
Figure 4-I	Heat and Moisture Loads for Caged Laying Hens at Various Air Temperatures ..... 154
Figure 5-I	Moisture Removal Rate Versus Temperature for Swine ... 155
Figure 6-I	Total Moisture Removed by Ventilation System of Test Room Housing Swine ..... 156
Figure 7-I	Curves for Estimating the Room Sensible Heat in a Hog House on the Basis of Animal Size and Room Temperature ..... 156
Figure 8-I	Building Sensible and Latent Heat, and Animal Weight for Sows and Litters ..... 157
Figure 9-I	Effect of Sheep Weight upon Heat Production at Air Temperature of 70 to 72°F ..... 158
Figure 10-I	Effect of Environment and Fleece Length on Heat Losses from Sheep ..... 159
Figure 11-I	Total and Latent Heat Production of Steers and Heifers in Relation to Temperature ..... 160
Figure 12-I	Total Vapourization Related to Age for Holstein, Jersey, Brown Swiss and Shorthorn Calves Grown at 50° and 80°F ..... 161
Figure 13-I	Stable Heat (Total Heat) and Latent Heat Produced by Dairy Calves ..... 162
Figure 14-I	Total Heat Production of Growing Turkeys ..... 163
Figure 1-K	Resistance of Grains and Seeds to Air Flow ..... 175
Figure 2-K	Resistance of Shelled Corn and Wheat to Low Air Flows .. 176
Figure 1-L	Approximate Slab Temperatures Obtained with Various Watt Densities and Ambient Air Temperatures ..... 188
Figure 1-M	Load/Span Graph for 3/8-in. Sheathing Grade Douglas Fir Plywood ..... 195
Figure 2-M	Load/Span Graph for 1/2-in. Sheathing Grade Douglas Fir Plywood ..... 196
Figure 3-M	Load/Span Graph for 5/8-in. Sheathing Grade Douglas Fir Plywood ..... 197
Figure 4-M	Load/Span Graph for 3/4-in. Sheathing Grade Douglas Fir Plywood ..... 198
Figure 5-M	Load/Span Graph for 3/4-in. (7-ply) Sheathing Grade Douglas Fir Plywood ..... 199
Figure 1-O	Free Stall with Earth Floor ..... 207
Figure 2-O	Free Stall with Paved Elevated Platform ..... 207

## PREFACE

The Canadian Farm Building Code 1975 has been developed as a guide for the design, construction, remodelling and evaluation of a wide variety of farm buildings other than living quarters.

The recommendations contained in it are designed to obtain safe and efficient performance and economy within such buildings. Designers should go beyond such recommendations when this is considered necessary for the fulfillment of the numerous multi-purpose requirements of many types of farm buildings.

The Code is divided up into three main parts: Basic Standards, Good Practice and Performance, and the Appendices.

Basic Standards deals primarily with the design and construction of new farm buildings and the alteration of existing ones. The detailed provisions refer primarily to structural sufficiency, fire prevention, health and sanitation, and are recommended minimums necessary not only for the protection of people, but also to minimize loss of livestock, poultry and stored produce.

Good Practice and Performance relates primarily to the functional requirements of farm buildings and to good construction practices. The recommendations unless otherwise stated are optimum, consistent with good management practices to promote efficient production and storage, economical construction and the protection of environmental quality.

The Appendices include technical data and information as reference material for the various Sections of the Code.

Publications cited in the text and from which information has been reprinted are listed in the Bibliography which follows Part 2 of this Code. If any names have been inadvertently omitted from this list, apologies are hereby offered.

Also included in the Bibliography are other documents that may be of help and interest to the reader.

The Standing Committee on Farm Building Standards of the Associate Committee on the National Building Code gratefully acknowledges the cooperation and assistance it has received from many different people and organizations in the preparation of this document.

---

Le Code national du bâtiment, ses suppléments et les documents qui s'y rattachent sont disponibles en français. On peut se les procurer en s'adressant au Secrétaire, Comité associé du Code national du bâtiment, Conseil national de recherches du Canada, Ottawa, Ontario K1A 0R6.

## LIST OF ABBREVIATIONS

Abbreviations of words and phrases in this Code have the following meanings:

AC	.....	alternating current
ACNBC	.....	Associate Committee on the National Building Code
amp	.....	ampere(s)
ASHRAE	.....	American Society of Heating, Refrigerating and Air-Conditioning Engineers
AWG	.....	American Wire Gauge
BOD	.....	biochemical oxygen demand
Btu	.....	British thermal unit(s)
bu.	.....	bushel(s)
CA	.....	controlled atmosphere
°C	.....	degree(s) Celsius
Can.	.....	Canadian
cfm	.....	cubic foot(feet) per minute
Col.	.....	Column
CSA	.....	Canadian Standards Association
cu ft	.....	cubic foot(feet)
DC	.....	direct current
deg.	.....	degree(s) of angle
diam.	.....	diameter
EFD	.....	equivalent fluid density
°F	.....	degree(s) Fahrenheit
ft	.....	foot(feet)
gal.	.....	gallon(s)
GVW	.....	gross vehicle weight
hr	.....	hour(s)
in.	.....	inch(es)
lb	.....	pound(s)
max.	.....	maximum
min.	.....	minimum
min.	.....	minute(s)
mph	.....	mile(s) per hour
NFPA	.....	National Fire Protection Association
NLGA	.....	National Lumber Grades Authority
No.	.....	number(s)
o.c.	.....	on centre
oz.	.....	ounce(s)
pcf	.....	pound(s) per cubic foot
psf	.....	pound(s) per square foot
psi	.....	pound(s) per square inch
PTO	.....	power take off
PVC	.....	poly (vinyl chloride)
R	.....	thermal resistance
sec.	.....	second(s)
SP	.....	self propelled
sq ft	.....	square foot(feet)
sq in	.....	square inch(es)
T & G	.....	tongue and groove
temp.	.....	temperature
U.S.	.....	United States
wt	.....	weight

# PART 1

# BASIC STANDARDS

## TABLE OF CONTENTS

<b>SECTION 1.1</b>	<b>DESIGN</b> .....	<b>3</b>
<b>Subsection 1.1.1.</b>	<b>General</b> .....	<b>3</b>
<b>Subsection 1.1.2.</b>	<b>Structural Loads and Procedures</b> .....	<b>4</b>
<b>Subsection 1.1.3.</b>	<b>Foundations</b> .....	<b>8</b>
<b>Subsection 1.1.4.</b>	<b>Wood</b> .....	<b>11</b>
<b>Subsection 1.1.5.</b>	<b>Unit Masonry</b> .....	<b>21</b>
<b>Subsection 1.1.6.</b>	<b>Concrete</b> .....	<b>22</b>
<b>Subsection 1.1.7.</b>	<b>Steel</b> .....	<b>23</b>
<b>Subsection 1.1.8.</b>	<b>Aluminum</b> .....	<b>24</b>
<b>Subsection 1.1.9.</b>	<b>Cladding</b> .....	<b>24</b>
<b>SECTION 1.2</b>	<b>HAZARDS AND SAFETY</b> .....	<b>24</b>
<b>Subsection 1.2.1.</b>	<b>Fire</b> .....	<b>24</b>
<b>Subsection 1.2.2.</b>	<b>Heating and Refrigeration</b> .....	<b>29</b>
<b>Subsection 1.2.3.</b>	<b>Electrical Services</b> .....	<b>30</b>
<b>Subsection 1.2.4.</b>	<b>Lightning</b> .....	<b>32</b>
<b>Subsection 1.2.5.</b>	<b>Safety</b> .....	<b>32</b>
<b>SECTION 1.3</b>	<b>HEALTH AND SANITATION</b> .....	<b>34</b>
<b>Subsection 1.3.1.</b>	<b>Water Sources</b> .....	<b>34</b>
<b>Subsection 1.3.2.</b>	<b>Environmental Protection</b> .....	<b>35</b>
<b>Subsection 1.3.3.</b>	<b>Sanitation</b> .....	<b>38</b>

# PART 1 BASIC STANDARDS

## SECTION 1.1 DESIGN

### SUBSECTION 1.1.1. GENERAL

The requirements of Section 1.1 apply to the design and construction of new farm buildings and to the alterations of existing farm buildings.

#### 1.1.1.1. Reference to Good Practice

In this Part where the term “good practice” is used or where such words as “adequate,” “sufficient,” “suitable,” “reasonable” or “effective” or derivatives thereof are used, it is intended to ensure sound, safe construction on the farm.

#### 1.1.1.2. Design

Farm buildings should be designed in accordance with the National Building Code of Canada 1975 unless stated otherwise.

#### 1.1.1.3. Conditions

The structural members of a farm building should be designed to have sufficient capacity to resist safely and effectively the following:

- (a) all loads due to the materials of construction (see Sentence 1.1.2.1.(1)),
- (b) all loads that may reasonably be expected to be applied to them during construction of the building,
- (c) all lateral loads due to earth and water pressure that may reasonably be expected to be applied on any part of the building below ground level,
- (d) all loads due to the intended use of the building that may be applied to them during the period of that use (see Sentence 1.1.2.1.(2)), and
- (e) all climatic loads that may be applied to them during the expected life of the building (in accordance with NBC Supplement No. 1, “Climatic Information for Building Design in Canada 1975.”)

#### 1.1.1.4. Materials and Building Components

Materials and building components not specifically described in this Part may be used provided their suitability has been established either by

- (1) tests that simulate anticipated service conditions, or
- (2) recognized engineering principles.

#### 1.1.1.5. Construction Methods

Construction methods should conform to good practice.

#### 1.1.1.6. Drawings and Specifications

Drawings should indicate:

- (1) the dimensions, location and size of all structural members and connections in sufficient detail to enable the design to be checked,
- (2) sufficient detail to enable the loads due to materials of construction incorporated in the building to be determined, and
- (3) all loads, other than those due to materials of construction incorporated in the building, used in the design of the structural members and connections.

### 1.1.1.7. Construction Safety Measures

Construction safety measures should conform to the ACNBC Canadian Construction Safety Code 1975 where applicable.

## SUBSECTION 1.1.2. STRUCTURAL LOADS AND PROCEDURES

### 1.1.2.1. Loads

#### (1) Loads due to materials of construction

The minimum design load due to materials of construction (see Table F-I, Appendix F) incorporated in farm building tributary to a structural member is

**Table I**

MINIMUM DESIGN FLOOR AND SUSPENDED LOADS DUE TO USE	
Use of Area of Floor	Design Live Load, psf
Cattle	
tie stall barns	70
loose housing (dairy or beef)	80
holding area	80
milking parlours	70
milkrooms or milkhouses	50 <sup>(1)</sup>
Sheep	30
Swine	
solid floors	40
Horses	100
Chickens	
floor-housing	40 <sup>(2)</sup>
cages	
floor supported <sup>(2)</sup>	
suspended	
full stair step double deck (no dropping boards)	75 lb/ft of cage row <sup>(6)</sup>
modified stair step double deck (with dropping boards)	100 lb/ft of cage row <sup>(3)</sup>
modified stair step triple deck (with dropping boards)	165 lb/ft of cage row <sup>(3)</sup>
Turkeys	40
Product storage	<sup>(4)</sup>
Machinery	<sup>(5)</sup>
Greenhouses	50
Maintenance shops	70 (See Subclause 1.1.2.1. (2)(c)(ii))
Column 1	2

#### Notes to Table I:

- <sup>(1)</sup> Floor constructions under bulk tanks should be designed according to the weight of the tank plus contents.
- <sup>(2)</sup> Where a space is provided for the accumulation of manure, the design load should be based on 65 psf per foot of depth. Design loads for floor supported cages require special consideration based on supported intervals and weights.
- <sup>(3)</sup> Based on 4 rows (double deck) or 6 rows (triple deck) with 2 birds per 8-in. cage, or 3 birds per 12-in. cage, and 2 in. of manure accumulated on dropping boards under upper cages.
- <sup>(4)</sup> The design load for product storage should be calculated on the basis of the individual weights (see Appendix F) but in no case less than 100 psf.
- <sup>(5)</sup> See Clause 1.1.2.1.(2)(c), Loads for Vehicle Storage.
- <sup>(6)</sup> Based on 4 rows with 2 birds per 8-in. cage, or 3 birds per 12-in. cage.

**1.1.2.1(1)**

- (a) the weight of the member itself,
- (b) the weight of all materials of construction incorporated in the building to be supported permanently by the member, including permanent service equipment, and
- (c) the estimated weight of possible future additions.

**(2) Loads due to use**

- (a) The minimum design load on any area of floor due to the use of the area is listed in Table I.
- (b) For loads for livestock on slotted floors and penned in groups, see Table II.
- (c) Loads for vehicle storage

(i) Vehicle storage (uniformly distributed): The minimum design load on an area of floor used for farm machinery with traffic limited to access and egress should be 150 psf, except where it is anticipated that the area will be occupied by either loaded farm trucks or large farm tractors (large tractors are those having a weight in excess of 13,000 lb where weight restriction includes effect of mounted equipment), then the design load should be 200 psf.

(ii) Vehicle storage (concentrated): In the absence of specific information, the minimum design loads due to probable concentrations of loads resulting from use of an area of floor is as follows:

- (1) For tractors and implements: 5000 lb per wheel.
- (2) For loaded trucks not exceeding 20,000 lb gross vehicle weight (GVW): 8000 lb per wheel.
- (3) For loaded trucks exceeding 20,000 lb GVW: 12,000 lb per wheel.

**Table II**

<b>FLOOR LOADS FOR GROUPS OF ANIMALS ON SLOTTED FLOORS</b>		
<b>Livestock</b>	<b>Live Loads for Design of a Floor Slat Unit, lb per ft of slat</b>	<b>Live Distributed Loads for Design of Slat Supports, lb per sq ft of floor</b>
Dairy cows and heifers	300	100
Beef cows and feeders	250	100
Dairy and beef calves to 300 lb	150	50
Sheep	120	50
Swine		
Weaners to 50 lb <sup>(1)</sup>	50	35
Feeders to 200 lb	100	50
Sows to 500 lb <sup>(2)</sup>	170	70
Column 1	2	3

**Notes to Table II:**

- <sup>(1)</sup> An alternate requirement, which may or may not dictate design, is one concentrated load of 220 lb (man + pig), so located first to give maximum moment then maximum shear in slats and slat supports.
- <sup>(2)</sup> Slotted floors in farrowing pens should be designed for a single concentrated load of 250 lb, located first to give maximum moment then maximum shear in slats and slat supports.



### 1.1.2.1(2)

(iii) Vehicle loading and processing: In cases where the area (minimal traffic or driveway) is to serve as a place for loading, unloading or processing, minimum design loads for such areas should be increased by 50 per cent to allow for impact or vibrations of the piece of machinery or equipment.

#### (d) Loads imposed by whole-plant silage in cylindrical tower silos

(i) Lateral pressure: For silage not over 70 per cent moisture (wet basis), concrete silos should be designed for lateral pressure as determined from the formula to follow. This is not intended for design of grain storage cylinders, but concrete silos designed from this formula are reasonably safe for normal shelled corn pressures (see Appendix A, Figure 1-A)

$$L = 100 + 1.92 \text{ hd}^{0.55}$$

where L = lateral pressure, psf

h = vertical distance from top of silo wall, ft

d = silo diam., ft.

(ii) For design of circumferential reinforcement in concrete silos, the allowable unit stresses should not be increased as permitted in low human occupancy buildings, under Clause 1.1.2.2.(1)(b).

(iii) Vertical wall loads: Walls for cylindrical silos should be designed for the dead load of the walls and roof plus the live loads due to suspended equipment and vertical wall friction of the silage. For top-unloading concrete silos, vertical wall friction may be approximated by assuming that the wall at its base supports the weight of silage above a right circular cone with base the floor of the silo and height of 3.2 times the silo diameter. See Appendix F, Table F-II for apparent density of silage.

(iv) Footing loads: The width of an annular ring footing should be based on providing sufficient bearing area at the critical soil bearing surface to support the silo roof, equipment, wall and footing, plus vertical wall friction (see Subclause 1.1.2.1.(2) (d) (iii)). Concrete footings should be reinforced when required to resist radial and tangential bending moments due to silo wall and soil reaction loads.

#### (e) Loads for design of horizontal silos

(i) Walls either vertical or outward-sloping up to 1 ft in 6 ft of height should be designed for a uniform distributed pressure of 100 psf applied perpendicularly to the wall surface regardless of depth.

(ii) If a tractor can be run close to the walls for packing, wall supports should be designed to resist a single point load of 400 lb applied perpendicularly to the wall surface at points causing critical stresses in the wall supports, in addition to the requirement in Subclause (i).

#### (f) Loads imposed by stored grain

For information relating to loads imposed by stored grain (shallow bins, deep bins, hopper bottoms, exposed horizontal girts, thermal effects, moisture effects, unloading effects) see Appendix A. Physical properties of stored crops are given in Table A-1.

#### (g) Loads imposed by stored potatoes

(i) Information relating to loads imposed by stored potatoes in deep bins is given in Figure 2-A, Appendix A.

(ii) The minimum design load for bin walls should include the combined effect of vertical and horizontal loads as given in Figure 2-A, Appendix A.

(iii) If the storage is located near a railroad mainline or a main highway, the minimum design load should be increased by 15 per cent to allow for vibration.

### 1.1.2.1

#### (3) Loads due to snow

Loads due to snow should be in accordance with Articles 4.1.7.1. to 4.1.7.4. of Section 4.1 (Structural Loads and Procedures) of the National Building Code of Canada 1975.

#### (4) Loads due to wind

Loads due to wind should be in accordance with Articles 4.1.8.1. to 4.1.8.3. of Section 4.1 (Structural Loads and Procedures) of the National Building Code of Canada 1975, except that the reference velocity pressure,  $q$ , for the design of structural members of low human occupancy farm buildings, as defined in Clause 1.1.2.2.(1)(a), may be based on a probability of being exceeded in any one year of 1 in 10.

#### (5) Loads due to rain

Loads due to rain should be in accordance with Article 4.1.7.5. of Section 4.1 (Structural Loads and Procedures) of the National Building Code of Canada 1975.

#### (6) Loads due to earthquakes

Farm buildings for low human occupancy need not be designed to withstand loads due to earthquakes.

### 1.1.2.2. Design Procedures

#### (1) Allowable stresses

The following clauses are designed to permit farm building design with a reduced overall safety factor in recognition of low risk of human life and low value of contents or low risk to loss of contents.

- (a) For purposes of structural design, "low human occupancy farm building" means a building or major portion having an occupant density no greater than one person per 500 sq ft during normal periods of use of 4 hr or longer in any 1 day. All other buildings including such buildings as processing rooms, workshops, auction or show arenas, or other areas likely to be occupied by groups of persons over extended periods should be considered as high human occupancy.
- (b) For the structural design of low human occupancy farm buildings, the allowable unit stresses in tension, compression, bending and shear as set forth in Tables V(a), (b), (c) and (d) for wood and the National Building Code of Canada 1975 for steel and concrete may be increased by 25 per cent, except as provided for in Subclause 1.1.2.1.(2)-(d)(ii). Alternatively, if the ultimate stress method is used for reinforced concrete, reduced load factors may be used for structural members subjected to live loads such as those given in Table I, in accordance with the following equation

$$U = 1.45 (D + L)$$

where  $U$  = Ultimate strength capacity,  
 $D$  = Dead load, and  
 $L$  = Live load.

- (c) Increases in allowable stresses for low human occupancy farm buildings in accordance with Clause 1.1.2.2.(1)(b) may be applied cumulatively with other modification factors given in the National Building Code of Canada 1975.

#### (2) Bracing for wind load

Buildings should be designed for loads determined in Sentence 1.1.2.1.(4). Supports, bracing, diaphragms and ties should be installed where required to adequately carry wind forces to the foundation and to prevent collapse, uplift, overturning and racking (horizontal shear).

### 1.1.2.2

#### (3) Connections

Connections should be designed as provided for in the National Building Code to carry any combination of live and dead loads provided for in the design. Increases in allowable stresses may be used in accordance with Sentence 1.1.2.2.(1). Where design procedures are not covered in the National Building Code of Canada 1975, standard engineering design procedures should be used.

#### (4) Deflections

- (a) Except where plaster, ceramics or other brittle materials form part of the assembly subject to deflection, the deflection of trusses, beams, floor and roof systems and similar structural components for farm structures generally need not conform to any specific limitations.
- (b) Deflections should be taken into account in the design based on live load to ensure that deflection under design load will not cause interference with the operation of doors, windows or equipment.
- (c) Where plaster, ceramics or other brittle materials form part of the assembly subject to deflections, the deflection should be limited to 1/360 of the span based on live load only.

## SUBSECTION 1.1.3. FOUNDATIONS

### 1.1.3.1. General

- (1) Farm buildings should be adequately supported by foundations.
- (2) Foundations should be interpreted to include footings and piling, walls, posts, piers, pilasters, rafts, slabs, grade beams, grillages or design forms which extend below grade for the purpose of supporting the farm building on the ground.
- (3) Foundations should be designed
  - (a) for the existing soil according to recognized engineering principles, or
  - (b) on the basis of past experience with the soil conditions where the foundation is to be built.
- (4) For special circumstances where piles are required, vertical loads should be supported by pile friction and/or end bearing as provided in Section 4.2 (Foundations) of the National Building Code of Canada 1975.

### 1.1.3.2. Footings

#### (1) General

- (a) Except as permitted in Clause (d) below, footings should be provided under foundation walls, columns, piers and poles to distribute the loads in accordance with the allowable bearing values of the supporting material in Table E-1, Appendix E.
- (b) The bearing surface on gravel, sand or silt shall not be less than 1 ft below grade; however, where this surface is more than 1 ft below grade and is embedded on all sides by the same soil, the maximum design bearing pressure of the soil is that listed in Table E-1, Appendix E, increased at 1 • rate of 20 per cent for each foot increase in depth, but not more than 200 per cent.
- (c) Where a foundation bears on gravel, sand or silt, and where the highest level of the ground water is or is likely to be higher than an elevation defined by the bearing surface less the width of the footing, the maximum bearing pressure shall be 50 per cent of that determined in Clauses (a) and (b) above.

### 1.1.3.2.(1)

- (d) Footings may be omitted if the safe bearing capacity of the soil or rock is not exceeded, and if the foundation is otherwise prevented from overturning.
- (e) Footings should be proportioned to minimize differential settlement.
- (f) If footings are to be supported on consolidated fill or unstable soil, they should be designed for these conditions, and the building so constructed that it will not be structurally damaged by settlement.

#### (2) Concrete footings for concrete, masonry or stone walls

##### (a) General

(i) Wall footings should be proportioned from the soil-bearing pressures and applied loads to minimize nonuniform settlement.

(ii) The bottom of footings should be below frost line, except when on rock or on coarse-grained soil, and should be well drained to at least the depth of frost penetration.

##### (b) Plain footings

(i) The minimum thickness of plain footings should be the minimum thickness of foundation walls prescribed in Clause 1.1.3.3.(1)(c).

(ii) The minimum width of plain footings should be the actual thickness of the supported foundation walls increased by the minimum thickness of foundation walls prescribed in Clause 1.1.3.3.(1)(c).

##### (c) Steel reinforced footings

The minimum thickness of steel reinforced footings should be 9 in.

#### (3) Concrete footings for columns and poles

(a) Column footings should be of sufficient size to carry the concentrated loads they must support.

(b) The minimum thickness of unreinforced column footings should be 8 in.

(c) Column footings more than 3 ft square should be reinforced, except where the thickness of the footing is equal to or greater than the greatest distance from the edge of the column to the edge of the footing.

(d) Precast pads for pole construction should not be used.

(e) Backfill around poles should be tamped earth, crushed stone or placed concrete.

#### (4) Wood footings for wood or metal walls, columns, posts or poles

(a) The minimum thickness of wood used in footings should be 1½ in.

(b) Wood footings should be designed so as not to exceed the allowable unit stresses specified in Article 1.1.4.2. for the grade and species used.

(c) Wood footings should be treated in accordance with Subsection 2.3.5.

### 1.1.3.3. Foundation Walls

#### (1) Concrete and unit masonry foundation walls

(a) Foundation walls should be designed to resist vertical and horizontal loads taking into account their unsupported length and height.

(b) Except as provided for in Clause (c) below, the minimum thickness of foundation walls should be 8 in.

### 1.1.3.3.(1)

#### (c) Minimum thicknesses

- (i) For buildings measuring less than 100 sq ft in floor area and with superstructure walls less than 8 ft in height, the minimum thickness should be 6 in.
- (ii) The minimum thickness of foundation walls should be 10 in. when
  - (1) the walls extend more than 4 ft into unstable and poorly drained soils,
  - (2) the walls are of concrete and extend more than 7 ft into the ground (for masonry walls see Clause 1.1.5.2.(1)(d)), and
  - (3) the total height of foundation and superstructure bearing walls is more than 24 ft but less than 35 ft.
- (iii) The minimum thickness of foundation walls should be 12 in. when the total height of foundation and superstructure bearing walls is more than 35 ft.
- (d) Foundation walls should extend at least 8 in. above ground. All exterior surfaces of basement or cellar walls below grade should be dampproofed below grade by
  - (i) parging the wall below finish grade with cement mortar at least  $\frac{3}{8}$ -in thick and coving the parging over the footing if the foundation consists of unit masonry,
  - (ii) filling the recesses resulting from the removal of form ties with cement mortar or sealing the recesses with dampproofing material if the foundation wall is of solid concrete, and
  - (iii) covering the walls with 2 coats of bituminous material or portland cement base paint.

#### (2) Wood-frame foundation walls

- (a) Wood-frame foundation walls should be designed to resist vertical and horizontal loads taking into account their unsupported length and height.
- (b) All horizontal and vertical framing, and plywood or lumber sheathing below grade and to a minimum height of 8 in. above grade, should be treated in accordance with Subsection 2.3.5., Wood Preservation.

#### (3) Backfilling

Backfilling should be placed carefully against the foundation walls to avoid damaging them or injuring any dampproofing, and to a level sufficiently above the finish grade so that future settlement of the backfill will not cause the final grade to slope towards the foundation.

### 1.1.3.4. Concrete Grade Beam Foundations

(1) A concrete grade beam foundation consists of a series of concrete piers that support a reinforced beam around the perimeter of the building.

#### (2) Piers

- (a) Piers should be proportioned to carry all vertical loads and should be reinforced to resist lateral forces and tensile stresses. The minimum cross-sectional area of steel should be 0.01 times the cross-sectional area of the piers.
- (b) The bottom of piers should have sufficient bearing area to distribute safely the loads over the supporting soil.
- (c) Piers should extend below frost line to a firm bearing surface.
- (d) The minimum diameter of piers should be 10 in.

#### (3) Grade beams

Grade beams should be designed to carry the live and dead loads of the building supported by the walls and should extend at least 8 in. above grade.

#### **1.1.3.5. Wood Post and Plank Foundations**

(1) Wood post and plank foundations should be designed to resist vertical and horizontal loads, taking into account their unsupported length and height.

(2) Both planks and posts should be treated in accordance with Subsection 2.3.5., below grade and to a minimum height of 8 in. above grade.

#### **1.1.3.6. Concrete Slabs-on-Grade**

(1) **Slabs-on-grade** (with perimeter foundation walls)

(a) The minimum thickness of concrete slabs-on-grade should be 4 in.

(b) The tops of slabs should be at least 4 in. above exterior finish grade.

(c) Uniformly distributed reinforcement for slabs-on-grade should weigh not less than 40 lb per 100 sq ft.

(d) Footings for loadbearing partitions should rest on undisturbed soil. The minimum thickness of such footings should be 5 in. measured from the underside of the slabs-on-grade and their minimum width should be 12 in.

(2) **Slabs-on-grade** (without perimeter foundation walls)

(a) The requirements for floating slabs should not be less than those for slabs-on-grade with foundation walls.

(b) The tops of slabs should be at least 8 in. above exterior finish grade.

(c) A tapered perimeter beam should be provided with a minimum width at the base of 8 in. The beam should extend not less than 12 in. into undisturbed soil.

#### **1.1.3.7. Wood Sills and Skirting**

(1) **Wood sills**

(a) Wood sills should have a minimum thickness of 1½ in.

(b) Wood sills on or below grade should be treated in accordance with Subsection 2.3.5.

(2) **Wood skirting**

Lumber or plywood skirting should be treated in accordance with Subsection 2.3.5. below grade and to a minimum height of 8 in. above grade.

### **SUBSECTION 1.1.4. WOOD**

#### **1.1.4.1. General**

(1) Except as otherwise provided for in this Subsection, the design of farm buildings or structural elements made from wood or wood products should be in accordance with Section 4.3 (Wood) of the National Building Code of Canada 1975.

(2) Full inch dimensions stated herein are nominal. Actual sizes should be in accordance with CSA O141-1970, "Softwood Lumber."

#### **1.1.4.2. Allowable Unit Stresses**

(1) For purposes of assigning allowable unit stresses and lateral nail loads, species are classified according to groups given in Table III.

(2)(a) All lumber assigned allowable unit stresses should be identified by the grade mark or certification of inspection issued by an association or independent grading agency in accordance with the grade marking provisions of CSA O141-1970, "Softwood Lumber." Sawn lumber should be graded in conformance with Table IV.

1.1.4.2.(2)

(b) Ungraded lumber should not be used in applications where the calculation of unit stresses is essential to the design.

**Table III**

<b>SPECIES GROUPS FOR WOOD</b>	
Group	Species
A	Douglas Fir Western Larch
B	Pacific Coast Hemlock Fir (Amabilis and Grand only)
C1	Pacific Coast Yellow Cedar Tamarack
C2	Jack Pine Eastern Hemlock
D	Balsam Fir Pine (Lodgepole and Ponderosa only) Spruce (all species) Alpine Fir
E1	Western Red Cedar Red Pine
E2	Western White Pine Eastern White Pine
F	Poplar (Aspen, Large Toothed Aspen and Balsam only)
Column 1	2

**Table IV**

<b>GRADING RULES FOR SAWN LUMBER<sup>(1),(2),(3)</sup></b>	
Species	Grading Rule
All species	NLGA Standard Grading Rules for Canadian Lumber, published by the National Lumber Grades Authority, December, 1970, effective March, 1971.
Column 1	2

**Notes to Table IV:**

- (1) The NLGA Standard Grading Rules for Canadian Lumber incorporate the "National Grading Rule for Dimension Lumber," a uniform set of grade descriptions and other requirements for softwood dimension lumber that forms part of all softwood lumber grading rules in the United States. Thus all dimension lumber throughout Canada and the United States is graded to uniform requirements.
- (2) Recommended allowable unit stresses also apply to all corresponding grades in the 1971 editions of standard grading rules published by the West Coast Lumber Inspection Bureau, Western Wood Products Association, Northern Hardwood and Pine Manufacturers Association and Northeastern Lumber Manufacturers Association.
- (3) Grades should be specified by intended end use and size classification (e.g. light framing, joist and plank, beam and stringer, post and timber, plank decking), as well as species and grade. Designers are advised to check the availability of grade, species and size of members required before specifying.

**1.1.4.2.**

(3)(a) Structurally graded lumber may be assigned allowable unit stresses listed in Tables V(a), (b) and (c), except that in “load-sharing systems” all such values other than modulus of elasticity may be increased 10 per cent.

(b) Graded lumber used in high human occupancy farm buildings may be assigned allowable unit stresses for “load-sharing systems” provided the framing elements are spaced at 24 in. or less.

(c) Graded lumber used in low human occupancy farm buildings may be assigned allowable unit stresses for “load-sharing systems” provided the framing elements are spaced at 48 in. or less.

“Load-sharing system” means a construction composed of 3 or more essentially parallel members so arranged or connected that excessive deflection in 1 of the members causes additional load transfer to adjacent members.

**Table V(a)**

<b>ALLOWABLE UNIT STRESSES FOR LIGHT FRAMING SIZES OF                      SAWN LUMBER CONFORMING TO THE NLGA STANDARD                      GRADING RULES FOR CANADIAN LUMBER, psi<sup>(1),(2),(3)</sup></b> (Thickness: 2 to 4 in.; width: 2 to 4 in.*; conditions: dry service; load: normal duration.)							
Species Group	Grade*	Bending		Compression		Tension Parallel to Grain	Modulus of Elasticity
		Stress at Extreme Fibre	Longitudinal Shear	Parallel to Grain	Perpendicular to Grain		
A	Select structural No. 1 No. 2 No. 3	2,200	90	1,600	460	1,250	1,930,000
		1,850		1,250		1,100	1,930,000
		1,500		1,000		900	1,740,000
		850		600		500	1,540,000
	Construction Standard Utility	1,100		1,150		650	1,540,000
		600		950		360	1,540,000
		300		600		150	1,540,000
Stud	850	600	500	1,540,000			
B	Select structural No. 1 No. 2 No. 3	1,600	75	1,300	235	950	1,620,000
		1,400		1,050		800	1,620,000
		1,150		800		650	1,460,000
		600		500		350	1,300,000
	Construction Standard Utility	800		950		500	1,300,000
		450		750		250	1,300,000
		200		500		100	1,300,000
Stud	600	500	350	1,300,000			
Col. 1	2	3	4	5	6	7	8



1.1.4.2.(3)

Table V(a) (Cont'd)

<b>ALLOWABLE UNIT STRESSES FOR LIGHT FRAMING SIZES OF                      SAWN LUMBER CONFORMING TO THE NLGA STANDARD                      GRADING RULES FOR CANADIAN LUMBER, psi<sup>(1),(2),(3)</sup></b> (Thickness: 2 to 4 in.; width: 2 to 4 in.*; conditions: dry service; load: normal duration.)							
Species Group	Grade*	Bending		Compression		Tension Parallel to Grain	Modulus of Elasticity
		Stress at Extreme Fibre	Longitudinal Shear	Parallel to Grain	Perpendicular to Grain		
C	Select structural	1,900	85	1,350	335	1,100	1,400,000
	No. 1	1,650		1,050		950	1,400,000
	No. 2	1,350		850		800	1,260,000
	No. 3	750		500		450	1,120,000
	Construction Standard	950		950		550	1,120,000
	Utility	550		800		300	1,120,000
	Stud	250		500		150	1,120,000
	Stud	750		500		450	1,120,000
D	Select structural	1,500	60	1,150	245	900	1,350,000
	No. 1	1,300		900		750	1,350,000
	No. 2	1,050		700		600	1,220,000
	No. 3	600		450		350	1,080,000
	Construction Standard	750		800		450	1,080,000
	Utility	450		650		250	1,080,000
	Stud	200		450		100	1,080,000
	Stud	600		450		350	1,080,000
E	Select structural	1,400	65	1,000	235	850	1,210,000
	No. 1	1,200		800		700	1,210,000
	No. 2	1,000		650		600	1,080,000
	No. 3	550		400		300	970,000
	Construction Standard	700		700		400	970,000
	Utility	400		600		250	970,000
	Stud	200		400		100	970,000
	Stud	550		400		300	970,000
F	Select structural	1,500	60	850	180	900	1,250,000
	No. 1	1,300		700		750	1,250,000
	No. 2	1,050		550		600	1,130,000
	No. 3	600		350		350	1,000,000
	Construction Standard	750		600		450	1,000,000
	Utility	450		500		250	1,000,000
	Stud	200		350		100	1,000,000
	Stud	600		350		350	1,000,000
Col. 1	2	3	4	5	6	7	8

**1.1.4.2.(3)**

\*Size: Allowable unit stresses for Construction, Standard and Utility grades apply only to members 4 in. in nominal width.

Allowable unit stresses for Select Structural, No. 1, No. 2, No. 3 and Stud grades of 3 × 4 in., and 4 × 4 in. sizes shall be the tabulated values multiplied by the factors below:

	Extreme Fibre in Bending	Tension Parallel to Grain	Modulus of Elasticity	All Other Stresses
Select structural	0.93	0.93	1.00	1.00
No. 1	0.62	0.62	0.80	1.00
No. 2	0.42	0.42	0.89	1.00
No. 3	0.35	0.35	1.00	1.00
Stud	0.35	0.35	1.00	1.00

**Notes to Table V(a):**

- (1) Allowable unit stresses for Appearance grade meeting the requirements of the authorities listed in Table IV shall be those listed for No. 1 grade, except that allowable unit stress in compression parallel to grain may be increased by 19 per cent.
- (2) Yellow Birch, Hard Maple and Red and White Oak conforming to the grades in this Table have the same allowable unit stresses as the corresponding grades of Group A species.
- (3) An approximate value for modulus of rigidity may be estimated at 0.065 times the modulus of elasticity.

**Table V(b)**

<b>ALLOWABLE UNIT STRESSES FOR JOIST AND PLANK SIZES OF                      SAWN LUMBER CONFORMING TO THE NLGA STANDARD                      GRADING RULES FOR CANADIAN LUMBER, psi<sup>(1),(2),(3)</sup></b> (Thickness: 2 to 4 in.; width: 6 in. or more; conditions: dry service; load: normal duration.)							
Species Group	Grade	Bending		Compression		Tension Parallel to Grain	Modulus of Elasticity
		Stress at Extreme Fibre	Longitudinal Shear	Parallel to Grain	Perpendicular to Grain		
A	Select structural	1,900	90	1,400	460	1,250	1,930,000
	No. 1	1,600		1,250		1,050	1,930,000
	No. 2	1,300		1,050		850	1,740,000
	No. 3	750		650		500	1,540,000
B	Select structural	1,400	75	1,150	235	900	1,620,000
	No. 1	1,200		1,050		800	1,620,000
	No. 2	950		850		650	1,460,000
	No. 3	550		550		350	1,300,000
C	Select structural	1,650	85	1,200	335	1,100	1,400,000
	No. 1	1,400		1,050		950	1,400,000
	No. 2	1,150		900		750	1,260,000
	No. 3	650		550		450	1,120,000
D	Select structural	1,300	60	1,000	245	850	1,350,000
	No. 1	1,100		900		750	1,350,000
	No. 2	900		750		600	1,220,000
	No. 3	500		500		350	1,080,000
Col. 1	2	3	4	5	6	7	8

1.1.4.2.(3)

Table V(b) (Cont'd)

Species Group	Grade	Bending		Compression		Tension Parallel to Grain	Modulus of Elasticity
		Stress at Extreme Fibre	Longitudinal Shear	Parallel to Grain	Perpendicular to Grain		
E	Select structural	1,250	65	900	235	800	1,210,000
	No. 1	1,050		800		700	1,210,000
	No. 2	850		650		550	1,080,000
	No. 3	500		400		300	970,000
F	Select structural	1,300	60	750	180	850	1,250,000
	No. 1	1,100		700		750	1,250,000
	No. 2	900		550		600	1,130,000
	No. 3	500		350		350	1,000,000
Col. 1	2	3	4	5	6	7	8

Notes to Table V(b):

- (1) Allowable unit stresses for Appearance grade meeting the requirements of the authorities listed in Table IV shall be those listed for No. 1 grade, except that allowable unit stress in compression parallel to grain may be increased by 19 per cent.
- (2) Yellow Birch, Hard Maple and Red and White Oak conforming to the grades in this Table have the same allowable unit stresses as the corresponding grades of Group A species.
- (3) An approximate value for modulus of rigidity may be estimated at 0.065 times the modulus of elasticity.

Table V(c)

<b>ALLOWABLE UNIT STRESSES FOR STRUCTURALLY GRADED SAWN TIMBER CONFORMING TO THE NLGA STANDARD GRADING RULES FOR CANADIAN LUMBER, psi<sup>(1)</sup> to <sup>(6)</sup></b> (Minimum dimension: 5 in.; conditions: dry service; load: normal duration.)							
Species Group	Grade	Bending		Compression		Tension Parallel to Grain	Modulus of Elasticity
		Stress at Extreme Fibre	Longitudinal Shear	Parallel to Grain	Perpendicular to Grain		
<b>(a) BEAMS AND STRINGERS* – Depth more than 2 in. greater than thickness</b>							
A	Select structural	1,700	125	1,100	460	1,000	1,720,000
	No. 1 structural	1,350	125	900	460	700	1,720,000
B	Select structural	1,250	100	900	235	750	1,450,000
	No. 1 structural	1,000	100	750	235	500	1,450,000
C	Select structural	1,500	120	950	335	850	1,250,000
	No. 1 structural	1,200	120	800	335	600	1,250,000
D	Select structural	1,150	85	800	245	700	1,210,000
	No. 1 structural	950	85	650	245	500	1,210,000
E	Select structural	1,100	95	700	235	650	1,120,000
	No. 1 structural	900	95	600	235	450	1,120,000
F	Select structural	1,150	85	600	180	700	1,160,000
	No. 1 structural	950	85	500	180	500	1,160,000
Col. 1	2	3	4	5	6	7	8

1.1.4.2.(3)

Table V(c) (Cont'd)

Species Group	Grade	Bending		Compression		Tension Parallel to Grain	Modulus of Elasticity
		Stress at Extreme Fibre	Longitudinal Shear	Parallel to Grain	Perpendicular to Grain		
(b) POSTS AND TIMBERS – Depth not more than 2 in. greater than thickness							
A	Select structural	1,550	125	1,200	460	1,050	1,720,000
	No. 1 structural	1,300	85	1,050	460	850	1,720,000
B	Select structural	1,150	100	950	235	800	1,450,000
	No. 1 structural	950	70	850	235	650	1,450,000
C	Select structural	1,400	120	1,000	335	900	1,250,000
	No. 1 structural	1,100	80	850	335	750	1,250,000
D	Select structural	1,100	85	850	245	750	1,210,000
	No. 1 structural	900	60	750	245	600	1,210,000
E	Select structural	1,050	95	750	235	700	1,120,000
	No. 1 structural	850	65	650	235	550	1,120,000
F	Select structural	1,100	85	650	180	750	1,160,000
	No. 1 structural	900	60	550	180	600	1,160,000
Col. 1	2	3	4	5	6	7	8

\*Allowable unit stresses in tension parallel to grain for “beam and stringer” grades may be increased by 14 per cent when grade restrictions applicable to the middle third of the piece are applied over the full length of the piece.

**Notes to Table V(c):**

- (1) Bending stresses for “beams and stringers” apply only when a member is loaded on the narrow face.
- (2) “Posts and timbers” graded to “beam and stringer” rules may be assigned beam and stringer stresses.
- (3) Yellow Birch, Hard Maple and Red and White Oak have the same allowable unit stresses as Group A for Select structural or No. 1 structural grades, respectively.
- (4) An approximate value for modulus of rigidity may be estimated at 0.065 times the modulus of elasticity.
- (5) With sawn members thicker than 4 in., which season slowly, care should be exercised to avoid overloading in compression before appreciable seasoning of the outer fibres has taken place, otherwise compression stresses for wet service conditions shall be used.
- (6) All grades listed in Table V(c) are graded for continuity, except for all grades of beam and stringer size class.

1.1.4.2.(3)

Table V(d)

<b>ALLOWABLE UNIT STRESSES FOR PLANK DECKING CONFORMING TO THE NLGA STANDARD GRADING RULES FOR CANADIAN LUMBER, psi<sup>(1),(2)</sup></b> (Thickness: 2 to 4 in.; width: 6 in. or more; conditions: dry service; load: normal duration.)				
Species Group	Grade	Bending Stress at Extreme Fibre	Compression Perpendicular to Grain	Modulus of Elasticity
A	Select Commercial	1,800	460	1,930,000
		1,550		1,740,000
B	Select Commercial	1,350	235	1,620,000
		1,150		1,460,000
C	Select Commercial	1,600	335	1,400,000
		1,350		1,260,000
D	Select Commercial	1,250	245	1,350,000
		1,050		1,220,000
E	Select Commercial	1,200	235	1,210,000
		1,000		1,080,000
Column 1	2	3	4	5

**Notes to Table V(d):**

(1) Bending stresses apply only when decking is loaded on the wide face.

(2) An approximate value for modulus of rigidity may be estimated at 0.065 times the modulus of elasticity.

(4) Reference should be made to CSA O86-1970, "Code of Recommended Practice for Engineering Design in Timber," for further information on modifications of allowable unit stresses. For low human occupancy farm buildings, these modifications are cumulative with those given in Clause 1.1.2.2.(1)(b).

**1.1.4.3. Nailed Connections**

(1) Lateral nail loads given in this section (except as noted) apply to standard, common nails or spikes driven perpendicularly to the side grain and loaded in the plane of the lumber surface at any angle to the grain. Nails or spikes should not be used where the principal load is in withdrawal.

(2)(a) For smooth-shank nails or spikes driven into softwood<sup>(1)</sup> lumber side grain without preboring, the following minimum spacings should be used where D is the nail shank diameter:

nail to nail spacing parallel to grain	12D <sup>(2)</sup>
nail to nail spacing perpendicular to grain	5D
unloaded edge distance	5D
unloaded end distance	10D
loaded edge distance	12D
loaded end distance	15D

(b) Spacing of spiral, square shank nails may be determined from Clause (a) but using the root diameter, d, (see Table VI) instead of D.

(1) Except Douglas Fir, where spacings should be increased 25 per cent.

(2) This spacing applies only if nails are alternately offset at least 1 nail diameter from a line parallel to the wood grain. Increase this spacing to 15D if nails are not offset.

1.1.4.3.(2)

Table VI

COMMON WIRE NAILS, SPIKES AND SPIRAL, SQUARE SHANK NAILS								
Type of Nail or Spike	Number Per Pound	Diameter D, in.	British Imperial Standard Gauge	Length L, in.	Unit Load P for Species Group, lb <sup>(1)</sup>			
					A	B, C1, E1	C2, D, E2	
Common round wire nails	794	0.072	15	1	32	26	21	
	536	0.080	14	1¼	38	31	25	
	322	0.092	13	1½	46	38	30	
	196	0.104	12	2	56	46	36	
	141	0.116	11	2¼	66	54	43	
	104	0.128	10	2½	76	62	50	
	67	0.144	9	3	91	74	59	
	40	0.176	7	3½	123	100	80	
	25	0.192	6	4	140	114	92	
	22	0.212	5	4½	162	133	106	
	18	0.232	4	5	186	152	122	
	13	0.252	3	5½	210	172	138	
9	0.276	2	6	241	197	158		
Common round wire spikes	18	0.252	3	4	210	172	138	
	8	0.300	1	6	273	224	179	
	7	0.300	1	7	273	224	179	
	5.2	0.324	0	8	307	251	201	
	4.6	0.324	0	9	307	251	201	
	3.6	0.348	00	10	342	279	224	
	2.9	0.348	00	12	342	279	224	
Common spiral square shank nails	143	D <sup>(2)</sup> d		10½	2½	60	49	39
		0.121	0.10					
	92	0.132	0.11	9¾	3	68	55	44
		57	0.160	0.13	8	3½	90	73
	41	0.176	0.15	7	4	104	85	68
23	0.212	0.17	5	5	138	113	90	
Column 1	2	3	4	5	6	7	8	

Notes to Table VI:

(1) See Table III for species groups.

(2) Cross-section dimensions for spiral, square shank nails are

D = diagonal (in.)

d = root diameter (in.).

(3) Lateral load per nail should be calculated from the following:

$$N = PK_S K_D K_H K_V K_Z$$

Where N = adjusted single shear lateral load per nail (lb)

P = unit nail load from Table VI

K<sub>S</sub> = service condition factor

K<sub>S</sub> = 1.00 for dry service condition

K<sub>S</sub> = 0.75 for wet service condition

### 1.1.4.3.(3)

$K_D$  = load duration factor

$K_D = 0.90$  for continuous loading (e.g. support of dead loads)

$K_D = 1.00$  for normal loading

$K_D = 1.15$  for 2-month loading (e.g. snow loads)

$K_D = 1.25$  for 1-week loading (e.g. concrete formwork)

$K_D = 1.33$  for 1-day loading (e.g. wind)

$K_D = 2.00$  for instantaneous loading (e.g. impact)

$K_H$  = hazard factor, see Clauses 1.1.2.2.(1)(a) and (b).

$K_H = 1.25$  for low human occupancy

$K_H = 1.00$  for high human occupancy

$K_V$  = side plate factor

$K_V = 1.25$  for metal side plates

$K_V = 1.00$  for all other conditions

$K_Z$  = penetration factor

$$K_Z = 0.75 + \frac{1.5}{L} (L_p - 0.5L) \leq 1.00$$

Where  $L$  = nail length (in.) see Table VI

$L_p$  = length of nail penetration into back member.

(4) Lateral load for nails or spikes in end grain should be 0.67 N.

(5) The allowable load for a row of  $n$  nails is  $n$  times the lateral load (N) for 1 nail.

(6) For 3-member joints where nails penetrate into the third member, double shear increases the allowable lateral load per nail as follows:

(a) Where nails are driven uniformly from both sides of the joint, and where nail penetration is at least 3 nail diameters into the third member, allow double the lateral load as determined in Sentence (3), using penetration factor  $K_Z = 1.00$ .

(b) Where nails are driven from one side only, allow for each nail the single-shear load  $N$  between the first and second members as determined in Sentence (3) with  $K_Z = 1.0$ , plus the additional load due to nailing into the third member. This additional load should also be determined as in Article 1.1.4.3., including  $K_Z$  calculated for nail penetration into the third member.

(7) For 3-member double-shear joints made with 2½-in., 6-gauge, medium hard spiral shank Truss Gusset nails driven from both sides through ½-in. Douglas Fir plywood side plates and 1½-in. lumber centre members, use the following values for lateral load  $P$ :

Spruce centre members 206 lb

Douglas Fir centre members 257 lb

These values for  $P$  should be adjusted as in Sentence (3) for service condition ( $K_S$ ), load duration ( $K_D$ ) and hazard factor ( $K_H$ ), but not  $K_Z$ .

### 1.1.4.4. Structural Assemblies

(1) Structural assemblies may be designed in accordance with the relevant clauses of CSA O86-1970, "Code of Recommended Practice for Engineering Design in Timber," or may be evaluated on the basis of load tests.

(2) Where the design of structural assemblies for low human occupancies is based upon load tests, representative sample assemblies selected at random should be capable of supporting

(a) 100 per cent of design dead and live loads for 1 hr without exceeding deflection limitations where applicable, and

(b) 100 per cent of design dead load plus 200 per cent of design live load for 24 hr without failure.

#### 1.1.4.4.

- (3) Where the design of structural assemblies for high human occupancy is based upon load tests, representative sample assemblies selected at random should be capable of supporting
- (a) 100 per cent of design dead and live loads for 1 hr without exceeding deflection limitations where applicable, and
  - (b) 100 per cent of design dead load plus 267 per cent of design live load for 24 hr without failure.

**1.1.4.5.** Glued structural assemblies including glued laminated timber should be exterior grade and designed in accordance with stresses given in CSA O86-1970, "Code of Recommended Practice for Engineering Design in Timber," incorporating the increase in stresses allowed in Clause 1.1.2.2.(1)(b).

### **SUBSECTION 1.1.5. UNIT MASONRY**

#### **1.1.5.1. General**

Except as provided for in this Section, the design of unit masonry should conform to the requirements of Part 1, Plain and Reinforced Masonry of NBC Supplement No. 4, "Commentaries on Part 4 of the National Building Code of Canada 1975."

#### **1.1.5.2. Allowable Heights and Minimum Wall Thicknesses**

(1) The minimum thickness of loadbearing solid masonry walls not exceeding 36 ft in height should be

- (a) 8 in. for the top 20 ft,
- (b) 10 in. for that portion more than 20 ft but less than 36 ft from the top,
- (c) 6 in. for buildings measuring less than 100 sq ft of floor area and with superstructure walls less than 8 ft in height, and
- (d) 12 in. for below grade walls extending more than 7 ft into the ground.

(2) The minimum thickness of loadbearing cavity walls not exceeding 25 ft in height should be 10 in.

(3) The minimum thickness of non-loadbearing partition solid masonry walls not more than 12 ft in height should be 4 in.

#### **1.1.5.3. Lateral Support**

(1) Every masonry wall should be supported at right angles to the wall face either horizontally by means of floor or roof systems or vertically by means of pilasters or crosswalls.

- (2) The maximum distance between lateral supports should be
- (a) 18 times the wall thickness for loadbearing walls, or
  - (b) 36 times the wall thickness for non-loadbearing walls.

#### **1.1.5.4. Lintels**

Concrete lintels should bear at least 8 in. on the wall on each side of openings.

#### **1.1.5.5. Roof Anchorage**

Roofs should be securely anchored to masonry walls to prevent lifting in high winds. Anchorage should be by means of anchor bolts of suitable size, properly spaced and adequately embedded in concrete, or by other effective methods.

Reference should be made to NBC Supplement No. 4, "Commentaries on Part 4 of the National Building Code of Canada 1975," for information on pressure and force coefficients for wind loads.



#### **1.1.5.6. Mortar**

See Appendix B, Table B-I for recommended mortar mixes.

#### **1.1.5.7. Laying**

- (1) All masonry should be built true and plumb.
- (2) Concrete masonry units should be dry when laid, and each unit should be properly embedded in mortar. Joints should be tooled.

### **SUBSECTION 1.1.6. CONCRETE**

#### **1.1.6.1. General**

Except as otherwise provided in this Section, the design of farm buildings or structural elements made from concrete or concrete products should be in accordance with Section 4.5 (Plain, Reinforced and Prestressed Concrete) of the National Building Code of Canada 1975.

#### **1.1.6.2. Air-Entrained Concrete**

Air-entrained concrete should be used for all concrete that will be exposed to freezing and thawing and to the use of de-icing agents.

#### **1.1.6.3. Ready-Mixed Concrete**

Ready-mixed concrete should conform to CSA A23.1-1973, "Concrete Materials and Methods of Concrete Construction." (See Appendix B, Table B-II, Guide for Ordering Ready-mixed Concrete.)

#### **1.1.6.4. On-Site Mixing**

See Appendix B, Table B-III for recommended mixes for on-the-job mixing.

#### **1.1.6.5. Concrete Floors**

- (1) The minimum thickness of floors, other than slabs-on-grade, should be 3½ in.
- (2) **Subgrade**
  - (a) The subgrade should be free of sod, large stones, organic matter, mud and debris and should provide uniform support under the floor.
  - (b) Fill material should be placed in 6-in. layers and should be well compacted.
- (3) **Joints**

Isolation joints should be used to prevent floating floors from bonding to foundation walls, columns or other rigid parts of buildings.

- (4) **Watertight floors**

- (a) A vapour barrier of 0.006 polyethylene or equivalent should be laid over the subgrade. Where strip material is used a 4-in. lap should be maintained.
- (b) In wet areas a minimum of 4 in. of granular material should be placed over the subgrade followed by a vapour barrier as outlined in (a). Adequate drainage by means of drain pipe should also be provided.

#### **1.1.6.6. Concrete Pavements**

- (1) The minimum thickness of pavements should be 4 in.
- (2) When drainage is required, a minimum slope of ¼ in./ft should be provided.
- (3) Isolation and contraction joints should be provided to control cracking.

### **1.1.6.7. Concrete Tower Silos**

#### **(1) Foundations**

- (a) Tower silos for whole-plant silage should have a floor and drainage system designed to prevent silage liquids from penetrating the soil under the footing and floor.
- (b) For wall friction and footing loads due to whole-plant silage, see Subclauses 1.1.2.1.(2)(d)(iii) and (iv).
- (c) For wall friction and footing loads due to stored grains see Appendix A, Loads Imposed by Stored Grain.
- (d) Foundation walls should be reinforced circumferentially to withstand the same lateral pressures as the bottom of the silo wall.

#### **(2) Walls**

- (a) Circumferential wall reinforcement should be spaced vertically at not over 30 in. for concrete stave silos and not over 24 in. for cast-in-place silos.
- (b) Circumferential wall reinforcement for silage silos should be designed to resist lateral pressures as in Subclauses 1.1.2.1.(2)(d)(i) and (ii).
- (c) Circumferential wall reinforcement for grain storage silos should be based on lateral pressures calculated from Appendix A, Loads Imposed by Stored Grain.
- (d) Construction tolerances
  - (i) The roundness of a concrete silo, expressed as the difference between the largest inside diameter and the smallest inside diameter, should not exceed 0.4 in. per ft in diam.
  - (ii) The plumbness of a concrete silo, expressed as the maximum distance that the silo departs from the plumb line, should not exceed 1 in. in 10 ft of height.
- (e) Concrete stave silos
  - (i) Concrete staves should be not less than 2 in. thick at any point.
  - (ii) Concrete staves should be made with concrete having a minimum 28-day compressive strength of 5000 psi.
  - (iii) Concrete staves should be yard dried for at least 28 days after wet curing and before erecting.
  - (iv) Exterior circumferential steel hooping should be tensioned to 60 per cent of yield point stress at time of erecting.
  - (v) The interior surface of the silo wall should be rendered impermeable to the penetration of silage liquids.
- (f) Cast-in-place silos
  - (i) The minimum wall thickness should be 5 in., except that if external hooping is used, the minimum thickness should be 4 in.
  - (ii) When embedded reinforcement is used, it should be protected by a minimum concrete cover of 2 in.
  - (iii) Design procedures for cast-in-place silos with heights equal to at least twice the diameters are presented in the report "Bin Wall Design and Construction" by Committee 313 of the American Concrete Institute.

### **SUBSECTION 1.1.7. STEEL**

Except as provided for in Article 1.1.2.2., the design of farm buildings or structural elements made from steel products should be in accordance with Section 4.6 (Steel) of the National Building Code of Canada 1975 and with Section 4.8 (Cladding) of the National Building Code of Canada 1975.

### **SUBSECTION 1.1.8. ALUMINUM**

Except as provided for in Article 1.1.2.2., the design of farm buildings or structural elements made from aluminum products should be in accordance with Section 4.7 (Aluminum) of the National Building Code of Canada 1975 and with Section 4.8 (Cladding) of the National Building Code of Canada 1975.

### **SUBSECTION 1.1.9. CLADDING**

The design, properties and application of cladding for farm buildings should be in accordance with Section 4.8 (Wind, Water and Vapour Protection) of the National Building Code of Canada 1975, except as provided for in Subsection 2.3.2. of this Code.

## **SECTION 1.2 HAZARDS AND SAFETY**

This Section deals with the hazards and methods of minimizing losses from fire and the prevention of accidents.

### **SUBSECTION 1.2.1. FIRE**

#### **1.2.1.1. Classification of Building Occupancies by Fire Hazards**

##### **(1) Division I buildings – high fire hazard**

This group includes buildings occupied by flammable, highly combustible or explosive materials and which, due to the quantities of material or inherent characteristics of the occupancy, constitute a special fire hazard such as

- (a) liquid or gaseous fuel storage in quantities exceeding 5 gal.,
- (b) ammonium nitrate fertilizer storage in quantities exceeding 100 lb,
- (c) hay and bedding storage, tobacco curing and stripping, mechanical crop drying (excluding small grains), livestock feed grinding and preparation, furnace and boiler rooms,
- (d) animal and poultry brooding (where supplementary heating equipment within the structures operating at a surface temperature of 325°F or greater creates an additional fire hazard), and
- (e) farm machine maintenance shops.

##### **(2) Division II buildings – moderate fire hazard**

This group includes buildings occupied by materials that are naturally less hazardous and/or which would burn if ignited with less intense heat than those of Division I such as

small grain drying and storage,  
animal and plant production (except as in Clause 1.2.1.1.(1)(d)),  
silage storage,  
fruit and vegetable preparation and storage,  
baled tobacco storage,  
milk storage and handling, and  
equipment and vehicle storage.

#### **1.2.1.2. Measures Designed to Prevent the Spread of Fire Within a Fire Compartment**

*“Fire compartment,” in this Section means a building or part of a building that is required by this Code to be separated from another building or part of a building by fire separation. A fire compartment may consist of one or several rooms or storeys.*

##### **(1) Fire-stopping**

- (a) All concealed spaces in wood framing and all furred spaces in masonry construction should be fire-stopped with wood blocking not less than 2 in. thick (nominal), or with

### 1.2.1.2.(1)

noncombustible material accurately fitted and arranged to prevent the spread of fire from one space to another.

- (b) Fire-stops should be located at floor, ceiling and roof levels to cut off all concealed vertical draft openings so that the maximum dimension of any concealed space is not greater than 10 ft.
- (c) A clearance of at least 2 in. should be provided between masonry or concrete chimneys and combustible framing. This dimension may be reduced to ½ in. for exterior chimneys. All spaces between masonry or concrete chimneys and combustible framing should be sealed at the top or bottom with noncombustible material.
- (d) Openings around exposed pipes or power shafting should be filled with noncombustible material or closed off by close-fitting metal caps at the ceiling and floor line and on each side of a wall or partition.

### 1.2.1.3. Measures Designed to Retard the Spread of Fire Between Abutting Compartments or Between Buildings Separated by Less than 20 ft of Open Space

*“Fire-protection rating” means the time in hours or fraction thereof that a closure, window assembly or glass block assembly will withstand the passage of flame when exposed to fire under specified conditions of test and performance criteria, or as otherwise prescribed in the National Building Code of Canada 1975.*

*“Fire-resistance rating” means the time in hours or fraction thereof that a material or assembly of materials will withstand the passage of flame and the transmission of heat when exposed to fire under specified conditions of test and performance criteria, or as determined by extension or interpretation of information derived therefrom as prescribed in the National Building Code of Canada 1975.*

(Fire-resistance ratings of elements or assemblies that have not been tested can be established on the basis of Supplement No. 2 to the National Building Code, Fire Performance Ratings 1975. Additional fire-resistance ratings of tested elements and assemblies are contained in Part 9 of the National Building Code of Canada 1975.)

*“Fire separation” means a construction assembly that acts as a barrier against the spread of fire and may not be required to have a fire-resistance rating or a fire-protection rating.*

(See Tables C-I to C-III in Appendix C for fire-resistance ratings of some typical farm construction.)

#### (1) Three-quarter-hour fire separation

Three-quarter-hour fire separation should be provided

- (a) to separate a compartment of Division I occupancy from all other occupancies,
  - (b) to subdivide buildings of Division I(c) into compartments not exceeding 5000 sq ft total floor area on one or more storeys, and
  - (c) to subdivide buildings of Division I(d) or Division II occupancies into compartments not exceeding 10,000 sq ft total floor area on one or more storeys. (This paragraph does not apply to open-front livestock buildings containing no stored hay or bedding.)
- (2) **Division I(a) occupancy, fuel storage and Division I(b) occupancy, ammonium nitrate fertilizer storage**

These occupancies should be separated from all other occupancies and from property lines by 60 ft of open space, unless local authorities permit or require some other separations. If fuel is stored in underground tanks, the separation distance may be reduced to 30 ft.

#### (3) Two-storey barns

A special hazard to livestock and humans exists where a large amount of hay and bedding could burn in the second storey over housed livestock such as cattle or horses. The mow floor and all closures should provide reasonable fire protection. No fire-resistance ratings are available for a situation with fire above the floor.

### 1.2.1.3.

#### (4) Fire separation

- (a) Every fire separation should be so designed, constructed and supported that it can be expected to remain intact and in position during the period of time that it is required to perform.
- (b) Every fire separation should be supported from the ground by construction having fire resistance at least equal to the supported separation.
- (c) Combustible construction which abuts or is supported by a fire separation shall be constructed in such a manner that its collapse under fire conditions will not cause the collapse of the fire separation.
- (d) Every wood joist should be fire-cut when it rests in a pocket in a noncombustible fire separation wall.

*“Fire-cut” when applied to wood joists and beams means that the ends are cut at an angle such that the top of each joist or beam does not penetrate appreciably into the supporting masonry wall, thereby permitting the joist or beam to fall freely without rupturing or overturning the wall.*

- (e) Where a noncombustible fire separation terminates on the exterior wall or roof surface, no combustible material other than sheathing and cladding should extend across the end of the fire separation to form a bridge where fire could cross. The space between the fire separation and the cladding should be tightly sealed by caulking with mineral wool or similar noncombustible material.
- (f) No combustible member of any kind should pierce a fire separation in such a way that it reduces its fire-resistance rating to less than  $\frac{3}{4}$  hr.
- (g) Where pipes or ducts which are not enclosed in shafts pass through a fire separation, they should be tightly fitted or fire-stopped to prevent the passage of smoke and flame from one separated area to another.

#### (5) Fire resistive closures

- (a) Openings and shafts penetrating fire separations should be fitted with fire resistive closures tested by a recognized laboratory in accordance with ASTM E152-73, “Fire Tests of Door Assemblies,” or similar test standards.
- (b) Doors in interior fire separations should have counterweights or other self-closing devices and should be kept closed during normal occupancy.
- (c) A duct that passes through a fire separation should be equipped with an automatic damper that operates at a temperature approximately 50°F above the maximum temperature that will normally be encountered in the system and that is equipped with spring catches, pins or hinges of corrosion resistant material.

### 1.2.1.4. Fire Separation by Open Space Between Buildings

#### (1) Construction types

- (a) Type I construction has a fire-resistance rating of less than 30 min. for either the walls or the ceiling and roof of the fire compartment.
- (b) Type II construction has a fire-resistance rating of at least 30 min. and has unprotected openings not exceeding 5 per cent of the exposing compartment wall area. Alternatively, Type II construction may have a fire-resistance rating of at least 45 min. and unprotected openings not exceeding 12 per cent of the exposing compartment wall area.

**1.2.1.4.(1)**

- (c) Type III construction has a fire-resistance rating of at least 45 min. and has unprotected openings not exceeding 5 per cent of the exposing compartment wall area.

(Where conditions of construction type are not met, use values for lower type construction.)

**(2)** To prevent the spread of fire by radiation, space separations should be as indicated in Tables VII(a), (b), (c) and (d).

(Table VII does not provide protection against wind carried embers where the adjacent buildings have exposed wall or roof openings or low sloped roofs which can be ignited by prolonged contact with the embers.)

**Table VII(a)**

<b>MINIMUM SPACE SEPARATIONS FOR PREVENTION OF RADIATION FIRE SPREAD TO ADJACENT BUILDINGS HAVING ASPHALT BASE SIDING OR MANUFACTURED HARDBOARD SIDING</b>			
Dimensions of Fire Compartment Seen by Adjacent Building, Length x Ridge Height, ft	Construction Type of Burning Building		
	I	II	III
	Space Separation, ft		
20 by 12	40	35	25
50 by 12	65	50	35
100 by 12	80	60	40
80 by 30	115	95	65
Column 1	2	3	4

**Table VII(b)**

<b>MINIMUM SPACE SEPARATIONS FOR PREVENTION OF RADIATION FIRE SPREAD TO ADJACENT BUILDINGS HAVING WOOD OR PLYWOOD SIDING</b>			
Dimensions of Fire Compartment Seen by Adjacent Building, Length x Ridge Height, ft	Construction Type of Burning Building		
	I	II	III
	Space Separation, ft		
20 by 12	35	30	20
50 by 12	55	45	30
100 by 12	65	55	35
80 by 30	105	90	60
Column 1	2	3	4

1.2.1.4.(2)

Table VII(c)

<b>MINIMUM SPACE SEPARATIONS FOR PREVENTION OF RADIATION FIRE SPREAD TO ADJACENT BUILDINGS HAVING SIDING OF NONCOMBUSTIBLE, NONREFLECTIVE MATERIAL,<sup>(1)</sup> AND HAVING NO WINDOWS OR OTHER OPENINGS IN THE EXPOSED SIDES</b>			
Dimensions of Fire Compartment Seen by Adjacent Building, Length x Ridge Height, ft	Construction Type of Burning Building		
	I	II	III
	Space Separation, ft		
20 by 12	30	30	20
50 by 12	50	40	25
100 by 12	55	45	30
80 by 30	85	70	50
Column 1	2	3	4

**Note to Table VII(c):**

<sup>(1)</sup> Materials such as asbestos-cement, painted metal, soiled metal or stucco which will absorb most of the radiation received.

Table VII(d)

<b>MINIMUM SPACE SEPARATIONS FOR PREVENTION OF RADIATION FIRE SPREAD TO ADJACENT BUILDINGS HAVING SIDING OF NONCOMBUSTIBLE, REFLECTIVE MATERIAL,<sup>(1)</sup> AND HAVING NO WINDOWS OR OTHER OPENINGS IN THE EXPOSED SIDES</b>			
Dimensions of Fire Compartment Seen by Adjacent Building, Length x Ridge Height, ft	Construction Type of Burning Building		
	I	II	III
	Space Separation, ft		
20 by 12	25	20	20
50 by 12	30	25	20
100 by 12	35	30	20
80 by 30	55	40	25
Column 1	2	3	4

**Note to Table VII(d):**

<sup>(1)</sup> Materials such as unpainted galvanized steel or aluminum which will reflect most of the radiation received.

(The National Building Code 1975, Part 3 (Use and Occupancy) gives fire separation distances for other situations which may occasionally be applicable to farm buildings. Distances given in the Code should only be used if the buildings comply with the other Code fire requirements, such as fire separation, noncombustible construction and window area.)

**1.2.1.5. Requirements for exits**

*“Exit (for people only)” in this Section means a means of egress that leads from the floor area to open space. An exit for this purpose may consist of a regularly used stairway or doorway. Alternatively, if the exit is provided for emergency use only, it may be an easily-opened door, window or panel, measuring at least 22 in. by 36 in. The bottom of the opening should be not less than 24 in. and not more than 36 in. above floor level. If the bottom of the wall opening is more than 8 ft above grade, a permanent outside ladder should be attached.*

### 1.2.1.5.

*“Exit (for horses and cattle)” in this Section means an opening from the floor area to open space; such opening may be a single door of from 3 ft to 3 ft 6 in. or a double doorway of 5 ft minimum width dimensions. Where the total change in floor elevation exceeds 10 in., a ramp or steps should be provided. Ramps or steps should meet the requirements shown in Clauses 2.1.1.1.(5)(k) and (l).*

*“Exit (for farrowing sows)” in this Section means an opening at least 22 in. by 36 in. located at floor level and leading to open space. Where the total change in floor elevation exceeds 10 in., a cleated or grooved ramp should be provided.*

(1) Every floor area should be served by exits to the extent that the travel distance to the nearest exit should not exceed

- (a) 75 ft in any occupancy in Division I (see Clause 1.2.1.1.(1)),
- (b) 100 ft in any other occupancy, except in occupancies for horses and cattle which should be 50 ft.

(2) At least 2 exits, as widely separated as possible, should be provided for areas exceeding 2000 sq ft, except when used for bulk crop storage where 1 exit is adequate.

## SUBSECTION 1.2.2. HEATING AND REFRIGERATION

### 1.2.2.1. General

(1) Oil-burning, gas-burning and electric heating and refrigeration equipment should be installed to conform to the following:

CSA B51-1972, “Code for the Construction and Inspection of Boilers and Pressure Vessels,”

CSA B52-1965, “Mechanical Refrigeration Code,”

CSA B139-1971, “Installation Code for Oil Burning Equipment,”

CSA B149.1-1971, “Installation Code for Natural Gas Burning Appliances and Equipment,” and Supplement No. 1-1973,

CSA B149.2-1969, “Installation Code for Propane Burning Appliances and Equipment,” and Supplement No. 2-1973, and

CSA C22.1-1972, “Canadian Electrical Code, Part I.”

The installation of solid-fuel-burning appliances, including mounting, clearances and requirements for safety devices, should conform to the ACNBC Canadian Heating, Ventilating and Air-Conditioning Code 1975.

(2) Where fuels are burned in greenhouses, a separate combustion air and flue system should be provided. Where carbon dioxide control is required for growth regulation, the use of specifically designed CO<sub>2</sub> generators is recommended.

(3) Movable gas-fired brooders and heaters for poultry should be connected to the fuel supply pipe with not more than 8 ft of flexible hose, or as required by Provincial regulations.

(4) Gas-fired infrared type poultry hovers should be provided with suitable dust filters to prevent combustible material contacting radiating surfaces.

(5) Fuel-fired forced air heating units for animal structures should be housed in a separate structure or a room having a fire-resistance rating as provided in Article 1.2.1.3. Such structure or room should be accessible only from outdoors.

(6) If any type of combustion heating unit with forced air is used in poultry houses and other dusty buildings, the cold air return duct should be equipped with a filter the area of which should be at least 4 times greater than normally used on heating units of comparable size. Alternatively, the cold air return may be connected to draw outside air provided the heating unit can give the required heat output without exceeding the ventilation requirements of the animals.

(7) Electric heat lamps should be of the hardened glass type and installed in approved lamp holders when used in buildings housing animals.



## **SUBSECTION 1.2.3. ELECTRICAL SERVICES**

### **1.2.3.1. Service Entrance and Metering**

(1) All buildings should be served from a stepdown transformer located centrally in relation to the electrical loading.

(2) The power supply authority and electrical inspection authority should be consulted for requirements and regulations governing service and metering equipment installation. Most power supply authorities will provide drawings and other assistance.

(3) All electrical installations should meet the requirements of the appropriate provincial or municipal statutes, or in the absence of such statutes the requirements of CSA C22.1-1972, "Canadian Electrical Code, Part I," should apply. An application for inspection by the inspection authority having jurisdiction is required for all electrical installations before work is commenced.

### **1.2.3.2. The Size of Service Wire for a Building Supplied at 120/240 Volts**

(1) The minimum size of wire should be determined by totalling the ampere values calculated in each of the following steps (a) to (e):

- (a) full load current of largest motor x 1.25 (where 2 or more motors of equal size are concerned, apply this factor to 1 only). See Table L-III in Appendix L for full load current of common sizes of motors,
- (b) the full load amperage of all other permanently connected equipment that is likely to be operated simultaneously,
- (c) one-half the full load amperage of all portable equipment that is operated at 120 volts,
- (d) all convenience outlets at  $\frac{3}{4}$  amp per outlet, and
- (e) all lighting outlets at  $\frac{3}{4}$  amp per outlet, or if restricted lighting is used (e.g. 25, 40, or 60 watts per outlet in a poultry house), calculate  $\frac{1}{2}$  of the total connected lighting load in amperes.

(2) The minimum size of wire required for a 120/240 volt 3-wire service should be on a maximum voltage drop of 2 per cent and length and type of wire (Tables L-I and L-II, Appendix L).

(3) The neutral conductor must be sized to carry the maximum unbalanced load, i.e.  $\frac{1}{2}$  of the connected 115-volt load (Table L-I, Appendix L) but must not in any case be smaller in size than the grounding conductor required to ground the service or feeder (Table L-V, Appendix L).

#### **(4) Determining service switch capacity**

- (a) The capacity of the service switch in each building should be the next higher rating to that required by the wire size calculated in Sentence 1.2.3.2.(1) or (2) whichever is the larger.
- (b) Where the continuous load is in excess of 80 per cent of the connected load, the switch should have the next higher capacity to that determined in Sentence 1.2.3.2.(1).

### **1.2.3.3. Emergency Service**

(1) A double-throw switch must be used in conjunction with a standby generator to prevent backfeed onto the line. The switch should be rated for total service ampacity on the line side and the ampacity of the generator on the standby side, unless a preferred load system is used whereby the double-throw switch only carries a portion of the total service ampacity.

(2) The generator should be properly grounded.

### **1.2.3.4. Lighting Outlets for Particular Locations**

(1) All lighting outlets should be wall switch controlled unless otherwise stated.

#### **1.2.3.4.**

(2) For wet and damp locations, lamp receptacles with non-metallic coverings should be used.

(3) Lighting fixtures in feed grinding rooms, feed storages, hay mows and other dusty locations should be of a dustproof type.

(4) At least 2 lighting outlets controlled by 3-way switches for each stairway should be provided, unless the head and foot of the stairway are adequately lighted from other sources.

#### **1.2.3.5. Locations of Convenience Outlets**

Where required convenience outlets should be located as high as can be reached conveniently to avoid damage from stock. Where practical these outlets should be mounted flush with the wall.

#### **1.2.3.6. Location of Wall Switches**

Wall switches should be mounted at least 52 in. above the floor line. Switches should not be located in areas where animals are penned unless protected from the animals.

#### **1.2.3.7. Multiple-Switch Control**

All spaces for which wall switch control is required, and which have more than one entrance, should be equipped with a multiple-switch control at each principal entrance.

#### **1.2.3.8. Outlets**

Convenience outlets should be provided for portable equipment to eliminate extensive use of extension cords. These outlets should be the 3-pronged grounded type.

#### **1.2.3.9. Motors on Fixed Equipment**

(1) All ventilating, refrigerating and other such equipment and controls should be approved and be installed in accordance with CSA C22.1-1972, "Canadian Electrical Code, Part I."

(2) Motors over  $\frac{1}{2}$  horsepower should be operated on a separate circuit.

(3) Motors over  $\frac{1}{2}$  horsepower should be on 230-volt circuits.

(4) Motors of  $\frac{1}{3}$  horsepower and under may be connected to convenience outlet circuits if provided with individual motor overload protection.

#### **1.2.3.10. Protection**

(1) Each branch circuit should be protected by fuses or circuit breakers whose ratings do not exceed the ratings of circuit conductors.

(2) Where motor starting currents are involved, time delay fuses or circuit breakers having suitable operating characteristics should be used.

(3) For a branch circuit the fixed electrical heating load should not be greater than 80 per cent of the ampacity of the conductor or overcurrent device.

(4) Ground fault interrupters should be installed on branch circuits supplying frost proof waterers, water pumps and outside outlets.

#### **1.2.3.11. Grounding**

(1) A grounding electrode should be installed at every major building on the farm where service is provided. The electrode should consist of one or more ground rods driven into the ground and suitably interconnected. Ground rods should be at least 10 ft in length.

### **1.2.3.11.**

(2) To reduce the hazard to humans and livestock from lightning and electrical failure in equipment or wiring, all metal components including those not directly connected with the electrical system such as stanchions and metal pens should be bonded together by a substantial copper conductor not less than No. 8 American Wire Gauge and connected to the electrical system ground.

(3) Provision should be made for the grounding of the non-current-carrying metal parts of all electrical equipment through proper receptacles, with particular attention given to portable tools and equipment.

(4) All non-current-carrying metal parts of water systems, including remote pumping systems, should be bonded to the system neutral by a separate conductor. When plastic pipe is used, a separate ground should be installed.

### **1.2.3.12. Floor Heating Cable**

Floor heating cable for use in livestock and poultry applications should be approved for that purpose.

### **1.2.3.13. Wiring**

(1) All wiring materials should be of the type approved by the electrical inspection authority or should conform to CSA C22.1-1972, "Canadian Electrical Code, Part I," for the anticipated service conditions.

(2) In locations where rodents may damage the insulation, wiring should be surface mounted or protected by rigid PVC conduit or other suitable approved material.

(3) Where conductors penetrate a vapour barrier, special precautions should be taken to prevent breathing and subsequent condensation. See CSA C22.1-1972, "Canadian Electrical Code, Part I," Rules 22-014 and 22-016 or the overriding electrical inspection authority regulation.

## **SUBSECTION 1.2.4. LIGHTNING**

### **1.2.4.1. Lightning Rods**

(1) Provincial lightning rod acts and CSA B72-1960, "Code for the Installation of Lightning Rods," should be consulted to determine materials and apparatus to be used in protecting buildings against lightning.

(2) Wire fences should have metal posts at intervals of not more than 165 ft.

## **SUBSECTION 1.2.5. SAFETY**

### **1.2.5.1. Overhead Obstructions**

Litter alleys and feed alleys should have no obstructions below 6 ft 6 in. from the floor.

### **1.2.5.2. Guard Rails**

(1) Where ramps, platforms, hay chutes, landings, etc. are more than 2 ft above adjacent floor or grade levels, guard rails should be provided except for loading docks.

(2) The top of guard rails should be not less than 36 in. and not more than 42 in. above floor level.

(3) For traffic areas likely to be occupied by humans only, guard rails should be capable of safely resisting a horizontal force of 100 lb at any point.

(4) Adequate guard rails should be provided for livestock.

### **1.2.5.3. Stairways**

- (1) Where an exit door opens outwards towards a stair, the full arc of its swing should be over a landing.
- (2) Where steps occur in walkways there should be a minimum of 2 risers.
- (3) Ramps should be provided where the total change in elevation is less than 10 in.
- (4) Stairs for human traffic should have 9-in. maximum rise, 8-in. minimum run and 9-in. minimum tread.
- (5) In any flight of stairs the rise, run and tread should be uniform.
- (6) Rectangular landings should be provided when stairs change direction.

### **1.2.5.4. Ladders**

- (1) If stairways are not feasible, permanently installed ladders should be provided when frequent access is required to locations more than 10 ft above floor or ground level.
- (2) Permanently installed ladders should terminate 5 ft above ground for child safety.
- (3) All roof ladders should be permanent.
- (4) Ladders should extend 3 ft above the upper landing, or other hand holds should be provided.
- (5) A clear space not less than 7 in. should be provided behind all rungs, steps or cleats.
- (6) The spacing of rungs, steps or cleats of any ladder should be uniform and should not exceed 12 in.
- (7) The distance between side rails should be 10 in. min.
- (8) Safety cages should be provided around permanently installed ladders more than 20 ft in height.

### **1.2.5.5. Bull Pens**

Bull pens should be provided with safety areas and a protected means of human egress.

### **1.2.5.6. Water Systems**

- (1) All water heating equipment and piping should
  - (a) be approved,
  - (b) be installed in accordance with the manufacturer's recommendation, and
  - (c) be equipped with combination temperature-pressure relief valves. Steam boilers should also be equipped with low water cut off safety relief valves.
- (2) Temperature-sensitive plastic pipe may be used for hot water heating applications only if the maximum pressure is maintained below safe pressure for that pipe at the maximum water temperature.
- (3) Covers of rot- and corrosion-resistant material should be provided for cisterns, wells and septic tanks.
- (4) Manhole covers or portions thereof should weigh at least 40 lb or be equipped with a locking device for child safety.

### **1.2.5.7. Liquid Manure Storage Tanks**

(1) Covered liquid manure storage tanks should have openings for equipment access. Access covers should weigh not less than 40 lb and should not float. Covers and openings should be designed to minimize the possibility of dropping the cover through the opening, or the cover should be secured with a safety chain.

(2) Covers over liquid manure storage tanks should be designed to support any expected loads imposed by animals or equipment.

(3) Open-top manure storage tanks or pits should be protected by a fence so designed as to exclude children and domestic animals.

(4) Where liquid manure tanks are open within animal buildings, maximum ventilation should be provided during agitation. Zero or positive room ventilation pressure should be provided while outside hatches are open into the manure storage. Humans and, if possible, animals should be evacuated.

(5) Where liquid manure tanks are located outside of animal buildings and have openings to the buildings, gas traps or valves should be installed to prevent dangerous gases from entering the buildings during agitation.

(6) To discourage entry, fixed ladders should not be permanently installed in liquid manure tanks.

### **1.2.5.8. Chemical Storage**

(1) Provision should be made for convenient and safe, locked storage of dangerous chemicals on the farmstead.

(2) Storage for ammonium nitrate fertilizer should be isolated from liquid fuel storage.

### **1.2.5.9. Suffocation**

(1) Sealed rooms such as walk-in coolers and controlled atmosphere storages should be equipped with door latches that open from inside the room and with warning lights to show when the room is occupied.

(2) Maintenance shops and other enclosed spaces where internal combustion engines may be operated should be equipped with exhaust systems which are independent of the building heating and ventilation systems.

## **SECTION 1.3 HEALTH AND SANITATION**

This Section relates to services and building requirements which will permit the maintenance of structures in a condition conducive to the good health of animals and humans and suitable for sanitary, nuisance-free production of agricultural products. Local authorities should be consulted concerning air and water pollution control regulations.

### **SUBSECTION 1.3.1. WATER SOURCES**

#### **1.3.1.1. General**

(1) Sources of water may be from a municipal water supply system, a deep well, a shallow well or spring provided that the source provides water of satisfactory quality as determined by the local health authorities. Where water is obtained from surface sources, and where testing indicates water from any source requires treatment, adequate facilities for treatment should be provided and treated water should be tested at regular intervals.

(2) Adequate precautions should be taken to avoid contamination.

### 1.3.1.2. Wells

- (1) Wells should be at locations that are safe from pollution.
- (2) Drilled wells should be provided with a casing of watertight material effectively sealed against pollution for a minimum distance of 1 ft above grade and 10 ft below grade and be equipped with a sanitary well cap.
  - (3) Dug wells should be
    - (a) provided with a tight-fitting impervious cover (see Sentences 1.2.5.6.(3) and (4)),
    - (b) provided with a watertight casing extending at least 10 ft below grade and 1 ft above grade, and
    - (c) located and so graded as to divert surface water.
  - (4) After construction or repair, wells should be
    - (a) pumped until the water runs clear, and
    - (b) disinfected.

### 1.3.1.3. Springs

- (1) Springs may be used as a source of water, but special precautions should be taken to avoid contamination.
- (2) Springs should be
  - (a) fenced to exclude animals,
  - (b) protected by diversion ditches, and
  - (c) protected by a box constructed of durable nontoxic material such as concrete, galvanized metal or other suitable material that is well flushed and disinfected before water is delivered to the supply lines. The box should have a tight-fitting impermeable cover (see Sentences 1.2.5.6.(3) and (4)).

### 1.3.1.4. Surface Sources

- (1) Where water from a surface source must be used for human consumption, special treatment is essential. Local health authorities should be consulted.
- (2) Open surface water sources should be fenced to minimize contamination by animals and for safety.

## SUBSECTION 1.3.2. ENVIRONMENTAL PROTECTION

### 1.3.2.1. General

- (1) All wastes on farms should be disposed of in a safe and sanitary manner. Wastes should not be allowed to drain into a receiving body of surface or subsurface water, but should be disposed of in such a manner that local pollution control requirements are met. Local authorities should be consulted before animal buildings or manure facilities are established.
  - (2)(a) A toilet and lavatory should be provided in areas used for the collection, handling, processing and storage of food products where a worker continuously occupies the building for 4 hr or more on a regular basis.
    - (b) Where buildings are grouped together in close proximity, and where there is no requirement for isolation (animal diseases, etc.), 1 convenient toilet and lavatory facility may serve the group of buildings.
    - (c) Disposal of human waste should be separate from animal and milk centre wastes, and should conform with the requirements of the local authorities.
  - (3) Plumbing for drainage of wastes in areas used for the collection, handling, processing and storage of food products should meet the requirements of Part 7 (Plumbing Services) of the National Building Code of Canada 1975.
  - (4) Livestock enterprises should be established only where acceptable means of waste disposal are available. See Article 2.2.6.5. for waste disposal by spreading on farm land.

### 1.3.2.1.

- (5)(a) Animal enterprises should be established at adequate distances from neighbouring residences. Local authorities should be consulted.
- (b) New neighbouring residences should be established at adequate distances from existing animal enterprises. Local authorities should be consulted.
- (6)(a) Feedlots or open pens should be located on well drained areas.
- (b) Diversion ditches or dykes should be installed to divert runoff from higher areas.
- (c) Runoff from feedlots should not be allowed to enter a receiving body of water.
- (d) Where necessary runoff from feedlots should be collected in holding facilities (see Article 2.2.6.8.).

### 1.3.2.2. Manure Storage

- (1) Where manure will be stored in solid form
  - (a) the storage capacity should be based on the type and number of animals and the frequency of manure removal (see Article 2.2.6.1.),
  - (b) the storage should be accessible by manure handling equipment, and
  - (c) the storage system should be designed to control liquids.
- (2) Where manure will be stored in liquid form
  - (a) the storage capacity should be based on the type and number of animals, the frequency of manure removal and the volume of required dilution water (see Article 2.2.6.1.), and
  - (b) the structure should be
    - (i) designed to permit agitation and removal of liquid manure by a floor sump at each point of removal,
    - (ii) provided with adequate ventilation for safety (see Sentence 1.2.5.7.(4)),
    - (iii) accessible by liquid manure handling equipment, and
    - (iv) designed to control the loss of liquid manure.

### 1.3.2.3. Dead Animal Disposal

- (1) Abandoned wells or springs should not be used for the disposal of dead animals.
- (2) Disposal tanks for dead birds and small animals should be
  - (a) located on high ground at least 150 ft from any well or spring used as a water supply,
  - (b) made of metal, concrete or other material approved by local authorities, constructed to exclude insects, rodents and water, and
  - (c) covered with tight fitting lids having locking devices (see Article 2.2.6.2.).
- (3) Burial pits for large animals should
  - (a) be located on high ground at least 150 ft from water courses, wells or springs, be above the expected water table and be at least 5 ft deep, and
  - (b) conform to local regulations.
- (4) Incinerators should be designed to consume all material and should meet the requirements for the incineration of Type 4 wastes in NFPA 82-1972, "Incinerators and Rubbish Handling," as well as any additional local requirements.

### 1.3.2.4. Milk Centre Wastes

*"Milk centre" means the milk room together with other areas associated with milking operations such as milking parlor, mechanical equipment room and lavatory.*

#### 1.3.2.4.

- (1) Where liquid manure storage is available the following procedures should be followed:
  - (a) all washings of manure from milking parlor floors and other floors should be delivered to a liquid manure tank or a lagoon,
  - (b) all wash waters from milkrooms, milkhouses and milking parlours should be delivered to a liquid manure tank or a lagoon, and
  - (c) a gas trap should be provided on the delivery pipe to the tank or lagoon.
- (2) Where liquid manure storage is not available, the following procedures should be followed:
  - (a) all solid manure should be removed and placed in the manure storage,
  - (b) all wash waters from milkrooms, milkhouses and milking parlours should be delivered to a lagoon or a sediment tank (see Article 2.2.6.3.).
  - (c) a gas trap should be provided on the delivery pipe to the lagoon or sediment tank,
  - (d) overflow from the sediment tank should be delivered to an underground disposal field (see Article 2.2.6.3.) or other form of final disposal approved by local authorities,
  - (e) provision should be made for periodic inspection and cleaning of the sediment tank, and
  - (f) provision should be made for periodic disposal of the lagoon effluent and sludge.
- (3) For disposal of human wastes, see Article 1.3.2.1.(2).

#### 1.3.2.5. Manure Lagoons

*“Manure lagoon” means a structure specifically designed for the biochemical and physical processing of animal wastes.*

- (1) The local authorities should be consulted before lagoon size and location is determined (see Article 2.2.6.4.).
- (2) A lagoon should be located
  - (a) in an area with adequate room for expansion,
  - (b) on the leeward side of the house,
  - (c) an adequate distance from any living area to avoid being a nuisance,
  - (d) to exclude, or in low rainfall areas to control, surface drainage to lagoons from adjacent areas,
  - (e) where it is not possible to contaminate surface and well water supplies,
  - (f) in a location exposed to the wind if aerobic or in a sheltered location if anaerobic, and
  - (g) where the subsoil is impervious; if pervious subsoil is encountered, a lagoon should be provided with an impervious lining.
- (3)
  - (a) A lagoon should be enclosed by a fence to exclude children and animals.
  - (b) Signs should be attached to the fencing to indicate the purposes of the lagoon and give warning of any danger involved.
- (4) **Mechanically aerated lagoons**

*“Mechanically aerated lagoon” means a lagoon in which the oxygen required for the processing of waste is supplied by a type of aeration device that mixes the waste and incorporates oxygen from the air.*



#### **1.3.2.5.(4)**

- (a) Aerated lagoons may be used for the processing of animal wastes where odour control is required.
- (b) Aerated lagoons should be
  - (i) designed according to the recommendations in Article 2.2.6.7.,
  - (ii) equipped with an aeration system designed to supply oxygen required for aerobic digestion, and
  - (iii) considered for seasonal use when mean temperatures are above 32°F.
- (5) Provision should be made for the disposal of lagoon effluent and sludge.

#### **1.3.2.6. Oxidation Ditches**

*An "Oxidation ditch" means a continuous loop channel in which animal waste is processed by an aeration device that mixes the waste and incorporates oxygen from the air.*

- (1) Oxidation ditches may be used for the processing of swine wastes.
- (a) Oxidation ditches should be located within a building and preferably beneath the slotted floor sections of the pens.
- (b) Oxidation ditches should be operated on continuous aeration and continuous overflow.
- (c) Wastes from oxidation ditches should not be discharged directly to natural bodies of water, but should be stored and spread on cropland or receive further processing (see Article 2.2.6.6. for design requirements).

### **SUBSECTION 1.3.3. SANITATION**

#### **1.3.3.1. Milk Production**

##### **(1) General**

Dairy barns, milking parlours and other buildings or parts thereof in which milk is produced or handled should conform to the special sanitary requirements of local authorities. They should be situated at well-drained sites and should be constructed and segregated to prevent product contamination.

##### **(2) Dairy barns**

###### **(a) General**

- (i) A dairy barn should house 1 species of animal only.
- (ii) The milking parlour should be separated from an attached housing area by a full partition broken only by self-closing doors.
- (iii) Storage for grain, mill feeds, hay and bedding should be provided and separated from the barn and milking area by dustproof walls and/or ceilings.
- (iv) Dairy barns should be provided with adequate ventilation and lighting for the number of animals housed therein (see Subsection 2.2.2. and Article 2.2.4.7.).

###### **(b) Construction**

- (i) A dairy barn having an overhead storage space should be provided with a dust-proof ceiling.
- (ii) The interior walls and ceilings of rooms in which animals are milked should have finished surfaces which will permit good sanitation. Interior window sills should be flush with the window frames or sloped downward to prevent accumulation of debris.

### 1.3.3.1.(2)(b)

(iii) Gutters and mangers should be concrete or other durable material finished to permit good sanitation.

(iv) Gutters, litter alley floors and feeding area floors should be paved with watertight durable materials.

(v) Floors intended for animal traffic should have a rough-textured surface to prevent slipping.

#### (c) Dimensions

(i) Tie stall platforms and litter alleys should slope to the gutter at least  $\frac{1}{4}$  in./ft,

(ii) for litter alley dimensions, see Subsection 2.1.1.1.(2)(b)(i) and (ii),

(iii) manure gutter dimensions should be adequate to provide storage for at least 1 day of manure production. See Clause 2.1.1.1.(2)(c) for minimum dimensions.

### (3) Milkhouses

#### (a) Location

(i) A milkhouse should not be part of a dwelling or of any building other than a dairy structure.

(ii) Where a milkhouse is directly attached to a dairy barn, a vapour-proof wall should be provided between the 2 structures. Openings should be fitted with a self-closing door.

(iii) Where the entrance to the milkhouse from the barn is by a vestibule, the openings should be fitted with self-closing doors.

(iv) Where the milkhouse is separated from the structure in which cows are milked, this space should be at least 4 ft wide.

(v) Where a milking parlour is an integral part of a milkhouse, the milking parlour should be separated from the milkhouse by a partition containing a self-closing door.

(b) Milkhouses should be designed to accommodate screen doors and screen windows or other suitable appliances which will effectively keep flies or other insects and vermin from entering the structures. Interior window sills should be flush with the window frame or sloped downward to prevent accumulation of debris.

#### (c) Construction.

(i) Milkhouse and milking parlour walls to 6 in. above the floor line and floors should be of concrete or other durable material finished with a smooth surface throughout. The walls above this height should be clad with material which presents a hard, smooth surface and which is relatively impervious to moisture.

(ii) The foundation, walls and ceiling should be well insulated to prevent the formation of condensation and possible freezing conditions in the milkhouse during cold weather.

(iii) The floors should be so constructed as to eliminate random cracking due to load or contraction.

(d) Milkhouses should be designed to permit the installation of milk cooling facilities which conform to CSA C22.2 No. 32-1954, "Electrically-Operated Refrigerating Machines," and installed in accordance with Provincial regulations.

(e) A milkhouse should be supplied with potable water (see Subsection 1.3.1.). For cleaning purposes the milkhouse should have

(i) a cold water hose bib,

### 1.3.3.1.(3)(e)

(ii) a hot water supply at 160°F for udder wash water and cleaning the milking system (see Clause 2.2.5.1.(2)(b)),

(iii) a double wash sink with mixing taps supplying hot and cold water, plus a single wash sink if automatic milking cluster and milk pipeline washing is required,

(iv) drain boards, and

(v) racks for proper storage of utensils used in the room.

(f) Drains (see Sentence 1.3.2.1.(3))

(i) Milkhouses should have a minimum of 1 trapped floor drain 4 in. or more in diameter plus sink drains suitably trapped.

(ii) Floor drains should be located at least 2 ft from the bulk milk tank outlet and not under any fixed equipment.

(iii) All drains should be suitably vented.

(g) Ventilation and lighting should be as given in Subsection 2.2.2. and Sentence 2.2.4.8.(5), respectively. Forced ventilation where provided in the milkhouse should be positive pressure.

(h) Milkhouses with bulk milk tanks

(i) A milkhouse in which a bulk milk tank is installed, or is to be installed, should have a reinforced concrete floor with a gradient of not less than ¼ in. in 1 ft to the drain.

(ii) The lights should be so located that they illuminate the inside of the tank when lids are open.

(iii) A milkhouse should be equipped with a hose-port having a self-closing exterior trap door at least 6 in. above the milkhouse floor or the outside ground level, whichever is higher, and should be located directly opposite the outlet valve on the bulk milk tank.

(iv) The space between the top of a bulk milk tank and the ceiling of the milkhouse should be sufficient to permit removal of the tank measuring rod but in no case less than 3 ft.

(v) Space should be provided in milkhouses to permit a bulk milk tank to be installed at least 6 in. above the floor of the milkhouse, but in the case of a tank with a rounded bottom, the lowest portion of the tank should be not less than 4 in. above the floor.

(vi) There should be an outside paved walk from the hose-port to the main milkhouse entry door.

(vii) A milkhouse should have passage widths of at least 2 ft around the bulk milk tank, 3 ft at the bulk milk tank outlet end and 4 ft in front of utensil racks and wash sink.

#### (4) Milk stands

Milk stands should be constructed to protect milk and milk cans from dust, direct rays of the sun, frost, rain and from any conditions or substances likely to impart odours or which would be detrimental to the quality of milk or manufactured milk products.

### 1.3.3.2. Contagious Disease Control Structures

These structures are designed to attempt to break the pathways along which diseases are transmitted.

#### (1) Special treatment and holding rooms

(a) These rooms should be constructed so as to permit ready cleaning and disinfecting.

### **1.3.3.2.(1)**

- (b) Floors should be constructed of concrete or other equivalent material coved to walls which are concrete or other equivalent material for a minimum of 12 in. above the floor level.
- (c) Walls and ceilings should be constructed of materials and finished so that the surface will be smooth and nonabsorbent.
- (d) Individual heating and ventilation systems should be provided.

### **1.3.3.3. Honey and Maple Products Processing Structures**

(1) All buildings or rooms in which honey or maple products are to be processed, packed or stored should be constructed in such a manner that they may be maintained in a clean and sanitary condition.

(2) If a toilet is installed in the structure, it should be in a separate room, properly drained and ventilated, and should have a wash basin in or adjacent to it.

# PART 2

# GOOD PRACTICE AND PERFORMANCE

## TABLE OF CONTENTS

<b>SECTION 2.1</b>	<b>SPACE ALLOWANCES</b>	<b>45</b>
<b>Subsection 2.1.1.</b>	<b>Animal Production</b>	<b>45</b>
<b>Subsection 2.1.2.</b>	<b>Plant Production</b>	<b>60</b>
<b>Subsection 2.1.3.</b>	<b>Product Storage</b>	<b>60</b>
<b>Subsection 2.1.4.</b>	<b>Service</b>	<b>61</b>
<b>SECTION 2.2</b>	<b>ENVIRONMENTAL SERVICES</b>	<b>62</b>
<b>Subsection 2.2.1.</b>	<b>Temperature and Humidity</b>	<b>62</b>
<b>Subsection 2.2.2.</b>	<b>Ventilation</b>	<b>66</b>
<b>Subsection 2.2.3.</b>	<b>Heating and Refrigeration Systems</b>	<b>67</b>
<b>Subsection 2.2.4.</b>	<b>Electrical Services</b>	<b>67</b>
<b>Subsection 2.2.5.</b>	<b>Water Supply</b>	<b>77</b>
<b>Subsection 2.2.6.</b>	<b>Environmental Protection</b>	<b>79</b>
<b>SECTION 2.3</b>	<b>CONSTRUCTION PRACTICES</b>	<b>88</b>
<b>Subsection 2.3.1.</b>	<b>General</b>	<b>88</b>
<b>Subsection 2.3.2.</b>	<b>Cladding</b>	<b>88</b>
<b>Subsection 2.3.3.</b>	<b>Vapour Barriers</b>	<b>92</b>
<b>Subsection 2.3.4.</b>	<b>Insulation</b>	<b>93</b>
<b>Subsection 2.3.5.</b>	<b>Wood Preservation</b>	<b>94</b>
<b>Subsection 2.3.6.</b>	<b>Drainage</b>	<b>94</b>

# PART 2 GOOD PRACTICE AND PERFORMANCE

This Part refers to the functional requirements of farm buildings, good construction practice, optimum conditions for efficient production and storage and economical construction and protection of environmental quality.

## SECTION 2.1 SPACE ALLOWANCES

This Section states the allowances for space and facilities for the animals and the products and services associated with the production.

### SUBSECTION 2.1.1. ANIMAL PRODUCTION

Location and arrangement of new animal production facilities should be based on considerations of dust, noise, odours, prevailing winds and the proximity and direction of neighbours. Also to be considered are site surface drainage, subsoil conditions, manure storage (type and location), manure pile or feedlot runoff detention, natural surface and subsurface waters, snow, space for expansion and traffic routes for farm operations.

#### 2.1.1.1. Dairy Cattle

##### (1) General

- (a) Where the dairy operator raises his own replacement stock, the total number of animals to be housed will normally be twice the number of milk cows.
- (b) Using the number of milking cows as a basis, the additional animals required for replacements may be estimated as follows:

heifer calves (0 to 3 months) . . . . .	12 per cent
bull calves (0 to 3 months if housed) . . . . .	12 per cent
heifers (3 to 10 months) . . . . .	20 per cent
heifers (10 months to 2 years) . . . . .	35 per cent
heifers (2 years to freshening) . . . . .	22 per cent
dry cows . . . . .	12 per cent

##### (2) Tie stall barns

- (a) (i) The floor to ceiling height should be a minimum clear distance of 8 ft.
- (ii) Clear height from floor to overhead services should be a minimum of 6 ft 6 in.
- (b) (i) Litter alleys should be 7 ft wide between gutters and 6 ft wide between gutters and wall (see also Subclause 1.3.3.1.(2) (c) (ii)).
- (ii) Where grate-covered gutters are used in lieu of open gutters, the combined width of litter alley and gratings should be 9 ft from stall platform to stall platform and 7 ft from stall platforms to walls.
- (c) Floor gutters should have a minimum width of 16 in. and a minimum depth of 6 in.
- (d) Feed alleys for cart feeding should be
  - (i) 4 ft wide with sweep in mangers,
  - (ii) 5 ft wide with high front mangers,
  - (iii) 6 ft wide with floor feeding from stall front to wall, and
  - (iv) 7 ft wide floor feeding from stall front to stall front.
- (e) Mangers for milk cows should be
  - (i) 20 to 24 in. wide if sweep-in type, and
  - (ii) 28 in. wide if high-front type.

2.1.1.1.(2)

- (f) Where mechanical conveyer feeding is used without a feed alley, feeding space should be
  - (i) 5 ft wide, stall front to stall front, and
  - (ii) 3 ft wide, stall front to wall.
- (g) Cross alleys should be at least 4 ft clear width.
- (h) Stall platform dimensions for stanchion tie stalls should be as in Column 3, Table VIII.

**Table VIII**

<b>DIMENSIONS FOR STANCHION TIE STALLS FOR DAIRY CATTLE</b>			
Animal Weight, lb	Stall Platform Width	Stall Platform Length	
		Without Trainers	With Trainers
800	3 ft 4 in.	4 ft 6 in.	4 ft 10 in.
1000	3 ft 8 in.	4 ft 8 in.	5 ft 0 in.
1200	4 ft 0 in.	5 ft 0 in.	5 ft 4 in.
1400	4 ft 4 in.	5 ft 4 in.	5 ft 8 in.
1600	4 ft 8 in.	5 ft 8 in.	6 ft 0 in.
Column 1	2	3	4

- (i) For chain tie stalls, platform lengths should be as in Column 4, Table VIII.
- (j) For single headrail type stalls, a stall platform 5 ft 6 in. to 5 ft 8 in. long may be used for cattle from 1000 to 1400 lb by providing headrail adjustment from 2 to 8 in. forward of the stall-front hardware.
- (k) Electrified cow trainers are recommended on all types of tie stalls.
- (3) **Loose housing**
  - (a) Manure pack resting areas should provide 60 sq ft of floor area per head for milking cows and 40 sq ft per head for dry cows and heifers. Clear height floor to ceiling should be 10 ft minimum.
  - (b) Free stall resting areas should have litter alley widths as in Table IX.

**Table IX**

<b>LITTER ALLEY WIDTHS BETWEEN FREE STALL CURBS</b>		
Stalls Per Row	Alley Width, ft	
	Solid Floors	Slotted Floors or Automatic Reciprocating Scraper
up to 5	7	7
6 to 16	8	7
17 to 36	10	8
Column 1	2	3

- (c) Alleys between rows of calf free stalls may be reduced to 4 ft min., and between calf free stalls and feed manger to 7 ft min., but in no case should there be less than the width of a tractor and blade if that is the method of cleaning.

### 2.1.1.1.(3)

- (d) Free stall dimensions should be as given in Table X. An adjustable headrail should span the stall dividers as shown in Figures 1-O and 2-O, Appendix O. For cows of 1200 lb average weight this headrail should be centred approximately 3 ft above and 5 ft 6 in. ahead of the back edge of the heel curbs.

**Table X**

FREE STALL DIMENSIONS FOR DAIRY CATTLE			
Cattle Housed	Stall Width	Stall Length Including Heel Curb	
		Stalls with Earth Floor <sup>(1)</sup>	Stalls with Paved, Elevated Floor <sup>(2)</sup>
Calves, 3 to 6 months	2 ft 3 in.	4 ft 0 in.	3 ft 9 in.
Calves, 6 to 10 months	2 ft 8 in.	5 ft 0 in.	4 ft 9 in.
Heifers, 10 months to 2 years	3 ft 6 in.	6 ft 9 in.	6 ft 6 in.
Heifers or cows, 800 lb average	3 ft 6 in.	7 ft 0 in.	6 ft 9 in.
Cows, 1000 lb average	3 ft 9 in.	7 ft 3 in.	7 ft 0 in.
Cows, 1200 lb average	3 ft 9 in.	7 ft 6 in.	7 ft 3 in.
Cows, 1400 lb average	4 ft 0 in.	7 ft 6 in.	7 ft 3 in.
Column 1	2	3	4

**Notes to Table X:**

<sup>(1)</sup> Refer to Figure 1-O, Appendix O.

<sup>(2)</sup> Refer to Figure 2-O, Appendix O.

- (e) A feeding area of at least 28 sq ft per head should be provided for milking cows, dry cows and heifers, and may be indoors or outdoors depending on climate.
- (i) Indoor and outdoor feeding areas should have a paved strip at least 11 ft wide adjacent to the feed bunk for cattle traffic.
- (ii) Outdoor feeding and exercise areas in regions where annual precipitation exceeds 20 in. should be completely paved, or alternatively, the unpaved area should be fenced to exclude cattle during wet conditions.
- (f) The feed bunk should allow
- (i) if self fed, 1 ft per head for milking cows and 8 in. per head for dry cows and heifers,
- (ii) if fed at time intervals, 28 in. per head for milking cows, dry cows and heifers,
- (iii) 30-in. width if animals feed from one side and 60 in. if animals feed from both sides,
- (iv) 22-in. max. height at the throat, and
- (v) 34-in. max. reach measured diagonally from the top of the throat board.
- (g) Minimum feeding area widths for cows and heifers should be 11 ft from feed bunk to wall or fence, 12 ft from feed bunk to free stall heel curb and 16 ft from feed bunk to parallel feed bunk.
- (h) Watering devices should be heated if required to prevent freezing, and should be provided at 1 sq ft of water surface per 50 head, or a minimum of 1 drinking unit per pen.
- (i) Water and feeding facilities may be located in free stall litter alleys but not in an open pen resting area.



### 2.1.1.1.

#### (4) Holding area

- (a) Where cows are milked in a milking parlour, a holding area is required providing 15 sq ft per 1200-lb cow. The holding area may be part of the regular animal traffic area suitably gated for separation of the cows to be milked.
- (b) The holding area should be so arranged and proportioned that cows can enter the milking parlour easily and without sharp turns.

#### (5) Milking parlours

The following dimensions relating to milking parlour stall hardware are approximate; final dimensions should be based on the recommendations of the equipment manufacturer:

- (a) The operator alley should be a minimum of 4 ft wide.
- (b) Floor slopes in operator pits should be in the direction that the operator normally faces during milking.
- (c) Stalls for herringbone-type parlours should consist of approximately rectangular areas 8 ft long (including feed box) by 22 in. wide, at an angle of 35 deg. to the operator alley. Minimum walk-through clearance between rump rail and mangers should be 2 ft 10 in.
- (d) Stalls for other parlours should be 2 ft 9 in. wide, 8 ft long for side-entering and 8 ft 6 in. long for walk-through types.
- (e) The cow alley should be at least 3 ft wide, increased to 4 ft at turns.
- (f) The ceiling height should be at least 7 ft clear distance above stall floor.
- (g) In cow traffic areas minimum clearance below fluorescent light fixtures should be 9 ft, and below other light fixtures should be 8 ft.
- (h) Operator floor area should be 2 ft 6 in. (minimum) to 3 ft 0 in. (optimum) below the cow platform.
- (i) The holding area floor may slope up towards the milking parlour cow entrance.
- (j) A single step with a rise of 6 to 8 in. may be located at the milking parlour cow entrance.
- (k) Ramp slopes to and from the cow platform should be not more than 4 in. per foot and should be provided with a roughened, cleated or grooved surface.
- (l) The rise of steps (where used in lieu of ramp) should be not more than 9 in. and the run should be 20 to 24 in.

#### (6) Auxiliary animal areas

- (a) One maternity pen of 10 ft x 10 ft min. dimensions, or alternatively 1 maternity tie stall without gutter, should be provided for every 20 to 25 cows.
- (b) With loose housing 1 treatment tie stall should be provided for every 20 to 25 cows in addition to the provision in Clause (a).
- (c) One isolation pen of 10 ft x 10 ft min. dimensions, separate from the main livestock area and equipped with a stanchion or tie for restraint should be provided for every 40 cows.
- (d) Calves 0 to 3 months of age should have individual stalls of 2 ft x 5 ft min. dimensions.
- (e) Calves 3 to 10 months of age should have 24 sq ft of pen per head with bedding or 16 sq ft per head with slotted floors. Alternatively, calves 3 to 10 months of age may be housed in free stalls (see Table X).

**2.1.1.1.(6)**

- (f) Heifers 10 to 24 months of age should have 35 sq ft of pen per head with bedding or 22 sq ft per head with slotted floor.
- (7) **Storage**
  - (a) Storage space for feed should be provided depending on management practices. For design purposes the following quantities for the milking herd may be used:
    - (i) 30 lb of hay per cow-day if no silage is fed,
    - (ii) 90 lb of silage per cow-day if no hay is fed,
    - (iii) where silage and hay are fed in combination, substitution should be made at the ratio of 3 lb of silage to 1 lb of hay, and
    - (iv) 6 to 15 lb of concentrate per cow-day or 1 lb of concentrate per 3 lb of milk produced.
  - (b) Approximately 50 per cent additional storage should be provided for the rest of the herd.
  - (c) Storage for bedding should be based on Table XI and on densities for bedding materials from Appendix F, Table F-II.
  - (d) For manure storage, see Sentence 2.2.6.1.(1).

**Table XI**

<b>BEDDING FOR DAIRY CATTLE</b>			
<b>Cattle</b>	<b>Manure Pack Loose Housing, lb/head-day</b>	<b>Free Stall Loose Housing, lb/head-day</b>	<b>Tie Stall Housing, lb/head-day</b>
Milk cows	10	0-2 <sup>(1)</sup>	8
Dry cows and heifers	5	0-2 <sup>(1)</sup>	4
Calves 3 to 10 months (group penned)	3	0-1 <sup>(1)</sup>	3
Column 1	2	3	4

**Note to Table XI:**

<sup>(1)</sup> Some operators use sand instead of conventional bedding materials, but not with liquid manure.

**2.1.1.2. Beef Cattle**

**(1) General**

- (a) Feed lots located in areas having less than 20 in. annual precipitation may be soil surfaced, but a paved strip should be provided in the feed lot adjacent to feed bunks and watering devices. The width of this strip should exceed the width of the tractor to be used for cleaning, and the paving should slope away from the feed bunk at least ½ in. per foot.
- (b) Feed bunks should have an adjacent step 12 to 16 in. wide by 6 in. to 8 in. high at the animal side.
- (c) Slotted floors with shelter may be used as an alternative to surfaced or unsurfaced feed lots.
  - (i) Slotted floors for calves to 3 months of age should have slat and slot widths of 3 in. and ¾ in., respectively. For calves an alternative to slotted flooring is 1 in. by 2 in., flattened, expanded metal mesh.
  - (ii) Slotted floors for beef cattle over 3 months of age (300 lb) should have slat and slot widths of 5 in. and 1½ in., respectively.

Table XII

ACCOMMODATIONS FOR BEEF CATTLE			
Accommodation	Cows and Bred Heifers	Yearlings	500-lb Calves
<b>Feed lot (without shed)</b>			
hard surfaced	80 sq ft	45 sq ft	40 sq ft
soil	300 sq ft	250 sq ft	150 sq ft
<b>Feed lot (with shed)</b>			
lot area			
hard surfaced	50 sq ft min.	25 sq ft min.	25 sq ft
soil	300 sq ft min.	250 sq ft min.	150 sq ft
shed area			
floor area	30 sq ft min.	16 sq ft min.	12 sq ft
clear height	10 ft min.	10 ft min.	10 ft
<b>Slotted floors</b>			
space per animal	30 sq ft	20 sq ft	12 sq ft
per cent of floor area slotted	100	100	100
<b>Maternity pens</b> (additional area)	1 pen/20 cows 10 ft by 10 ft minimum (not slotted)		
<b>Water</b>			
surface area	1 sq ft per 25 head	1 sq ft per 25 head	1 sq ft per 30 head
<b>Bedding storage</b> (except for slotted floors)	5 lb/head-day	3 lb/head-day	3 lb/head-day
<b>Feed bunk</b>			
length per head			
simultaneous feeding	2 ft 2 in.	1 ft 8 in.	1 ft 6 in.
full feeding			
roughage	8 in.	8 in.	6 in.
mill feed	3 in.	3 in.	2 in.
height at throat	18 in.	18 in.	18 in.
max. reach (top of throat board to bottom inside corner)	34 in.	30 in.	24 in.
<b>Feed storage</b>			
hay, without silage	25 lb/head-day (maintenance only)	15 lb/head-day (maintenance only)	12 lb/head-day (maintenance only)
silage, without hay	75 lb/head-day (maintenance only)	4½-5 lb/day per 100 lb live wt (fattening)	35 lb/head-day (maintenance only)
grain and concentrate	Cows: no grain Fattening 2-year olds; 1½-2 lb/day per 100 lb live wt	may substitute grain for hay at 1 lb grain per ½ lb hay	1½-2 lb/head- day
Column 1	2	3	4

**2.1.1.2.(1)**

- (d) For manure storage requirements, see Sentence 2.2.6.1.(1).
- (2) Accommodations for beef cattle should be as shown in Table XII.
- (3) For dairy beef calves see Clauses 2.1.1.1.(6)(d) and (e).

**2.1.1.3. Sheep**

- (1) Accommodations for sheep should be as shown in Table XIII.
- (2) For manure storage see Sentence 2.2.6.1.(1).

**Table XIII**

<b>ACCOMMODATIONS FOR SHEEP</b>		
<b>Accommodation</b>	<b>Ewes or Rams</b>	<b>Feeder Lambs</b>
<b>Feed lot</b>		
hard surfaced soil <sup>(1)</sup>	15 sq ft per head 70 sq ft per head	6 sq ft per head 30 sq ft per head
<b>Open front shed</b>		
floor area	15 sq ft per pregnant ewe 10 sq ft per dry ewe	6 sq ft per head
ceiling height	9 ft	9 ft
<b>Slotted floors<sup>(2)</sup></b>		
area per animal	7 sq ft	4 sq ft
per cent slotted floor area	100	100
slot width	¾ in.	5/8 in.
slat width	2 to 3 in.	2 to 3 in.
<b>Lambing pen (not slotted)</b>		
claiming pen only	4 x 4 ft min.	
lambing and claiming pen	4 x 5 ft min.	
<b>Feed rack<sup>(3)</sup></b>		
length per head	16 in. group feeding 6 in. self-fed	12 in. group feeding 4 in. self-fed
height at throat	12 in. small breeds 15 in. large breeds	10 in. small breeds 12 in. large breeds
<b>Feed storage</b>		
hay	5 lb/head-day (large breeds) 3 lb/head-day (small breeds)	2 lb/head-day
grain	1/3 lb/head-day	½ lb/head-day (maintenance) 1 to 2½ lb/head-day (finishing)
<b>Bedding storage</b>	¾ lb/head-day	¼ lb/head-day
<b>Water</b>		
surface area	1 sq ft/40 head	1 sq ft/40 head
Column 1	2	3

**Notes to Table XIII:**

- (1) Feed lots located in areas having less than 20 in. precipitation per annum may be soil surfaced, but at least a 6-ft-wide paved strip should be provided for the animal feeding area adjacent to each feed bunk. The paved strip should be included in feed lot area requirements and should be sloped away from the feed bunk at least ½ in. per foot.
- (2) An alternative to slotted floors for ewes, rams or lambs is 1 in. by 2 in. 9-gauge expanded and flattened metal. Expanded metal floors may be covered with a solid panel to retain bedding for lambing.
- (3) Some sheepmen prefer the 6-sided feeders allowing 2 ft on a side for 2 sheep.

### 2.1.1.4. Swine

(1) Accommodations for swine should be as shown in Table XIV.

(2) (a) Group pens with solid or partially-slotted floors should have a length of 2.5 to 4 times the width.

(b) The solid part of the floor should have a  $\frac{1}{4}$  to  $\frac{3}{4}$  in. per ft slope increasing length-wise towards the location of manure collection.

(c) Minimum width of group pens should be 5 ft for sows of up to 400 lb, 3 ft for weaners and 4 ft for feeders of up to 200 lb.

(3) For manure storage see Sentence 2.2.6.1.(1).

Table XIV

ACCOMMODATIONS FOR SWINE			
Accommodation	Sows	Weaners (under 50 lb)	Feeders (50-200 lb)
<b>Feed lot</b>			
hard surfaced area	25 sq ft per sow	8 sq ft per pig	20 sq ft per pig
pasture area	1 acre per 2 sows with litters	1 acre per 25 pigs	1 acre per 10 pigs
<b>Confinement housing</b>			
solid floor pen area	20 sq ft per sow under 400 lb 24 sq ft per sow over 400 lb	4 sq ft per pig	6 sq ft per pig under 100 lb 8 sq ft per pig 100 to 200 lb
<b>Slotted floor pens</b>			
total pen floor area	16 sq ft per sow under 400 lb 20 sq ft per sow over 400 lb	3 sq ft per pig	4 sq ft per pig 50 to 100 lb 6 sq ft per pig 100 to 150 lb 8 sq ft per pig 150 to 200 lb
slotted floor area	35 to 100 per cent of pen <sup>(1)</sup>	30 to 100 per cent of pen <sup>(1)</sup>	30 to 100 per cent of pen <sup>(1)</sup>
slot width	1 to 1½ in.	¾ to 1 in. <sup>(2)</sup>	1 to 1½ in.
slat width	1½ to 5 in.	1½ to 5 in.	1½ to 5 in.
<b>Partition height</b>	3½ ft	2½ ft	3 ft
<b>Self-feeder length</b>	(not recommended)	2 in. per pig	3 in. per pig
<b>Feed trough length</b>	1½ ft per sow	10 in. per pig	13 in. per pig
<b>Individual feeding stall dimensions</b>	1½ ft wide 2 to 6 ft long		13 in. x 5 ft
<b>Gestation tie stalls</b>			
width	2 to 2½ ft		
length, feed trough to gutter	5 to 5½ ft <sup>(3)</sup>		
to slotted floor	4 ft		
<b>Gestation pen stalls</b>			
width	2 ft 2 in.		
length	6 ft		
height	3½ ft		
Column 1	2	3	4

2.1.1.4.

Table XIV (Cont'd)

Accommodation	Sows	Weaners (under 50 lb)	Feeders (50-200 lb)
<b>Farrowing pen dimensions</b> side creeps, early weaning (4 weeks)	5 by 7½ ft <sup>(4)</sup>		
side creeps, late weaning (6 to 7 weeks)	6 by 7½ ft		
front creep	5 by 9½ ft		
clearance under creep partitions	8 to 10 in.		
<b>Water</b>	1 waterer per 15 sows or minimum of 1 per pen	1 waterer per 25 pigs or minimum of 1 per pen 600 lb feed from birth to 200 lb	1 waterer per 20 pigs or minimum of 1 per pen
<b>Feed</b>	1 ton per sow per year	650 lb birth to 200 lb	650 lb birth to 200 lb
Column 1	2	3	4

Notes to Table XIV:

- (1) With partly slotted pen floors, the slotted portion should be 0 to 1½ in. below adjacent solid floor.
- (2) An alternative to slotted floors for weaners is 9-gauge expanded steel (flattened), ¾ x 2-in. o.c. mesh size, preferably hot-dip galvanized. Floor area adjacent to the self-feeder may be temporarily covered with a solid panel such as plywood to conserve feed and to provide a sleeping platform.
- (3) For sows tail-to-tail in 2 rows with a single shallow gutter or slotted floor between, allow a minimum of 13-ft total excluding feed troughs.
- (4) 5-ft minimum pen width is the sum of 2-ft heated feeding creep, 2-ft sow space and 1-ft unheated creep.

2.1.1.5. Horses

- (1) Accommodations for horses should be as shown in Table XV.

Table XV

ACCOMMODATIONS FOR HORSES			
Accommodation	Two-Year Old or More		Yearling
	Small Breeds	Large Breeds	
<b>Tie stall dimensions</b> width length box stall	5 ft 10 ft including manger 10 ft by 10 ft	5 ft 12 ft including manger 12 ft by 14 ft	8 ft by 10 ft
<b>Hay manger</b> width height at throat	2 ft 3 in. 3 ft 2 in.	2 ft 3 in. 3 ft 6 in.	2 ft 2 ft 9 in.
<b>Grain box dimensions</b>	1 ft by 2 ft	1 ft by 2 ft	1 ft 6 in. by 10 in.
<b>Feed storage (per year)</b> hay per horse grain per horse	2 tons 40 bushels	2 tons 80 bushels	1 ton 30 bushels
Column 1	2	3	4

**2.1.1.5.**

(2) For large breeds ceiling height over tie stalls, box stalls and horse passages should be 9 ft minimum.

(3) Tie stall flooring should be resilient, sloped to the rear of the stall, and should provide underdrainage for urine (for example, wood planking supported on spacer blocking).

(4) Box stall flooring should be soft material such as packed earth.

(5) Minimum alley widths for horse barns should be as follows:  
 alleys between rows of stalls or pens, 10 ft,  
 rear alleys between stalls and wall, 6 ft,  
 feed alleys, 4 ft,  
 cross alleys, 4 ft.

(6) Equipment such as light fixtures, ventilation fans and water lines should have guards or should be so located as to minimize contact by horses.

(7) For manure storage, see Sentence 2.2.6.1.(1).

**2.1.1.6. Chickens**

(1) Floor housing for laying hens and breeding flocks should be as shown in Table XVI.

**Table XVI**

<b>FLOOR HOUSING FOR LAYING HENS AND BREEDING FLOCKS</b>			
<b>Accommodation</b>	<b>Floor System</b>		
	<b>Deep Litter Floor Dropping Pits, Under Roosts</b>	<b>Combination ½-½ Wire or Slat Floor, ½-½ Deep-Litter Floor</b>	<b>Complete Wire or Slat Floor</b>
<b>Floor area per hen</b> egg-strain breeds heavy breeds (over 5 lb)	2 sq ft 3 sq ft	1.0 sq ft 1.5 sq ft	0.5 sq ft min. 1.0 sq ft min.
<b>Feeding space per 100 hens</b>	If hand fed 20 ft of double-sided troughs or 4 round hanging feeders (pan diameter 16 in.). For automatic feeding reduce feeding space 50 per cent		
<b>Watering space per 100 hens</b>	2 watering cups, 2 five-gal. fountains or 60 linear in. of drinking troughs		
<b>Nesting space per 100 hens</b>	20 nests, 10 in. by 12 in. by 13 in. high for both light and heavy breeds or 1 community nest 2 ft by 8 ft.		
Column 1	2	3	4

**(2) Cage housing for egg-strain laying chickens**

(a) Cage floor area for multiple-bird laying cages should be 64 sq in per bird at 3½ lb (2 birds in a cage 8 x 16 in., 3 birds in a cage 12 x 16 in., etc.). For 4½-lb birds the cage floor area should be increased to 72 sq in per bird (2 birds in a cage 8 x 18 in., etc.).

(b) Cage floor area for multiple-bird breeder cages should be 96 sq in per bird (for example, 20 hens and 2 cockerels in a cage 22 x 96 in. and 23 in. high).

(c) Feeder trough space should be 4 in. per bird with 2 or more birds per cage.

2.1.1.6.(2)

- (d) Where carts are used for feeding and egg gathering, a clear passage of 32 in. should be provided between cage rows and from cage rows to longitudinal walls.
- (e) Clear end passages of 8 ft from cage equipment to end walls should be provided if required for turning feed and egg carts.

**Table XVII**

<b>REQUIREMENTS FOR THE GROWING OF CHICKEN BROILERS, ROASTERS AND REPLACEMENT PULLETS ON FLOOR SYSTEMS</b>				
Accommodation	Age, weeks			
	0-2	3-6	7-10	11-20
Floor area per bird, sq ft <sup>(1)</sup>	0.5	0.75	0.75	1.5 (light breed) 2.0 (meat breed)
Length of feed space per bird, in. <sup>(2)</sup>	1	2	3	3
Watering space for 100 birds <sup>(2)</sup>	2 fountains at 1 gal. each	automatic troughs, 60 linear in. or 2 fountains at 3 gal. each	automatic troughs, 60 linear in. or 2 fountains at 3 gal. each	100 linear in.
Brooding requirements warm room brooding (60° F min.)  cold room brooding	0.05 sq ft/chick usable floor under canopy brooder to 4 or 5 weeks <sup>(3)</sup> or 125 chicks/250-watt heat lamp or equivalent to 4 or 5 weeks  0.10 sq ft/chick under canopy brooder to 8 or 10 weeks <sup>(3)</sup> or 70 chicks/250-watt lamp or equivalent to 8 or 10 weeks			
Roosting requirements		if roosts are used, 0.25 ft/ bird	if roosts are used, 0.45 ft/ bird (light breeds) 0.5 ft/ bird (heavy breeds, except broilers)	
Column 1	2	3	4	5

**Notes to Table XVII:**

- <sup>(1)</sup> Expanding floor area may be provided by removable plastic curtains or other suitable materials hung from the ceiling. Total building area should be based on the requirements of the time schedule of bird removal.
- <sup>(2)</sup> Where troughs are used from both sides, 1 in. of trough equals 2 in. of feed or watering space.
- <sup>(3)</sup> Ewing, W.R. Handbook of Poultry Nutrition, Section 767, p. 1114. Published by W.R. Ewing, S. Pasadena, Cal., U.S.A.



**2.1.1.6.**

**(3) Egg holding and egg grading rooms**

- (a) The floors in egg holding and grading rooms should be constructed of concrete or equivalent material finished with a smooth surface throughout, and should be sloped to a suitably trapped drain.
- (b) Ventilation and refrigeration should be provided in egg holding rooms. Where egg holding rooms have walls and ceilings exposed to outside temperatures, supplementary heating may also be required.
- (c) Ventilation and heating should be provided in egg grading rooms.

**(4)** The requirements for floor rearing of chicken broilers, roasters and replacement pullets should be as shown in Table XVII. Broilers are normally marketed in 8 to 9 weeks and roasters in 12 to 14 weeks. Replacement pullets are normally moved from rearing to laying housing at 18 to 20 weeks.

**(5)** The requirements for cage rearing of replacement pullets should be as shown in Table XVIII.

**Table XVIII**

<b>REQUIREMENTS FOR THE GROWING OF REPLACEMENT PULLETS IN CAGE SYSTEMS</b>				
Age, weeks	Cage Floor Area, sq in	Watering		Feed Trough, in. per bird
		birds per nipple	birds per cup	
0-6	25	15	25	1
6-18	45	8	12	2
18+	60	8	12	2
Column 1	2	3	4	5

**Table XIX**

<b>CUMULATIVE FEED REQUIREMENTS FOR GROWING CHICKENS</b>				
Age, weeks	Cumulative Feed Requirements, lb/bird			
	Broilers	Roasters	Replacement Pullets	
			Egg Strain	Meat Strain
2	0.72	0.74	0.4	0.5
4	2.39	2.58	1.3	1.7
6	4.93	5.33	2.4	3.5
8	8.29	8.96	3.8	5.7
9	10.22	-	-	-
10	-	13.11	5.6	8.2
12	-	17.08	7.6	11.0
14	-	20.60	9.7	14.0
16	-	-	11.9	17.2
18	-	-	14.2	20.6
20	-	-	16.6	24.0
22	-	-	19.1	27.6
24	-	-	21.7	31.3
Column 1	2	3	4	5

**2.1.1.6.**

(6) (a) Feed storage requirements for laying hens should be based on average consumption of 0.25 lb/hen-day for light breeds and 0.35 for meat breeds.

(b) Feed storage requirements for growing chickens should be based on Table XIX.

(7) The capacity of on-farm bulk feed storage for any one feed mix should be based on a minimum delivery of 3 tons and a maximum holding time of 4 weeks.

(8) For manure storage, see Sentence 2.2.6.1.(1).

**2.1.1.7. Turkeys**

(1) Accommodations for turkey breeding flocks should be as shown in Table XX.

**Table XX**

ACCOMMODATIONS FOR TURKEY BREEDING FLOCKS		
Accommodation	Requirements	
Floor area per bird, all breeds	5 sq ft	
Feed space per bird	3 linear in.	
Watering space per bird	1.5 linear in.	
Nest space per 5 hens	1 nest, 14 in. by 24 in. by 24 in.	
Feed consumption per bird-day	Broiler strain	Heavy strain
toms	0.75 lb	1.0 lb
hens	0.5 lb	0.75 lb
Broody space <sup>(1)</sup>	0.5 sq ft of wire floor, no bedding, well lighted	

**Note to Table XX:**

<sup>(1)</sup> Area separate from breeding pen used to isolate "broody" breeder hens and restore egg production.

**Table XXI**

CUMULATIVE FEED REQUIREMENTS FOR GROWING TURKEYS				
Age, weeks	Cumulative Feed Requirements, lb/bird			
	Turkey Broilers (Mixed Sexes)	Broilers (Hens)	Large White Turkeys	
			Hens	Toms
2	0.65	0.61	0.50	0.50
4	1.79	2.08	1.98	2.30
6	4.38	5.04	5.01	5.51
8	7.26	8.59	8.96	10.19
10	11.64	13.86	13.26	16.43
12	16.75	20.02	18.01	23.62
14	22.57	26.66	24.01	32.72
16	-	-	30.12	42.48
18	-	-	37.37	52.87
20	-	-	48.35	65.04
22	-	-	57.17	78.34
24	-	-	-	91.93
Column 1	2	3	4	5

### 2.1.1.7.

#### (2) Requirements for brooding turkey poults

##### (a) Floor area per bird should be as follows:

0 — 6 weeks old	1½ sq ft
6 — 19 weeks old	2½ sq ft
19 — 30 weeks old	3 sq ft
30+ weeks old	5 sq ft

(b) Feed space per bird should be increased from 2 in. at 2 weeks to 3 in. at 19 weeks and older.

(c) Watering space per bird should be increased from ¾ in. at 2 weeks to 1½ in. at 19 weeks and older.

(3) For manure storage, see Sentence 2.2.6.1.(1).

(4) Cumulative feed requirements for growing turkeys are given in Table XXI.

### 2.1.1.8. Fur-Bearing Animals

#### (1) Mink

##### (a) Buildings for housing mink should

(i) be located on ground which has good water drainage both surface and subdrainage,

(ii) be located where drifting snow does not create problems, and

(iii) have earthen floors bedded slightly to facilitate dropping removal.

(b) Mink structures should be surrounded by a 4-ft guard fence buried at least 6 in. underground, and designed to exclude other animals.

##### (c) A feed room should

(i) be attached directly to the compound,

(ii) have a holding room refrigerated to 0°F or colder, and

(iii) include a grinding and mixing room.

(d) A pelting room should be provided for killing, cooling, pelting, fleshing, cleaning and stretching of the fur product.

(e) The breeder pen for confinement of bred females and their kits should be 18 x 30 in. and 18 in. high. Space should be allowed at the end of the breeder pen for an attached nest box 10 x 10 x 18 in.

(f) The pelter pen for confinement of mink raised for the pelt should be 15 to 18 in. high, 9 to 12 in. wide and 24 to 30 in. long, with a nest box at the end.

(g) Mink pens arranged side-by-side in rows should be spaced 1½ in. apart or, alternatively, they should be separated by sheet metal or closely-spaced wire mesh.

(h) Minimum clear hallway width between rows of mink pens should be 40 in.

(i) Pens should be elevated at least 18 in. above the ground.

(j) For manure storage, see Sentence 2.2.6.1.(1).

#### (2) Foxes

Individual fox pens should be 4 ft by 7 ft by 3 ft high with the pen bottom elevated 2 ft above grade.

### 2.1.1.8.

#### (3) Rabbits

(a) Buildings for the housing of rabbits for meat production should be insulated and equipped with mechanical ventilation for the control of environmental temperature and humidity.

#### (b) Rabbit cages

(i) One cage 24 x 36 in. and 15 in. high should be provided for each doe in the herd.

(ii) One buck cage having the same dimensions as a doe cage should be provided for each 7 to 10 doe cages.

(iii) One fryer cage should be provided for every 3 doe cages.

(iv) Cages should be made of 16-gauge welded, galvanized wire or equivalent with bottoms ½ in. x 1 in., fronts and sides 1 in. x 1 in. and remaining parts 1 in. x 2 in. On doe cages the ½ in. x 1 in. “baby saver” wire should extend up the ends and sides to 4 in. above the bottom.

(v) Nest boxes for doe cages should be wood, open top, 20 in. long x 12 in. wide x 9 in. deep with a 6-in. wide opening at one end. The bottom of the opening should be 7 in. above the floor.

#### (c) Cage arrangement

(i) Cages are normally arranged with 2 doe cages stacked above 1 fryer cage, with 5-in. vertical clearance between cages for dropping trays. The floor of the fryer cage is normally 19 in. above the passage floor.

(ii) Cages should be arranged in back to back rows, with up to 24-in. clearance provided between the backs of the cages for manure removal, cage servicing, etc.

(iii) Minimum clear width of feed passages between the cage rows should be 40 in.

(iv) Cross alleys at the end of cage rows should be at least 4 ft.

#### (d) Feeding and watering devices

(i) A self-feeding hopper with capacity for 15 oz. of pelleted feed should be provided for each cage. The hopper lip should be 4 in. above the floor of the cage.

(ii) One watering device per cage should be provided. If gravity supply drippers are used, they should be placed 7 to 9 in. above the cage floor and just outside the rear wall of the cage.

(e) Floor gutters for droppings should be provided under the cage rows and should extend 3 in. beyond the front of the cages. For liquid flushing, gutters should be 10 in. deep with sides sloping from the feed passage to a 24-in.-wide flat bottom in the gutter. Gutters should be sloped slightly to outlet at the end.

#### (f) Feed requirements

(i) Storage should be provided based on 100 lb of prepared feed per doe and litter, assuming 4 to 5 litters per year with average litter size of 8.

(ii) Storage should be provided based on 10 lb of prepared feed per buck per month.

#### (g) Utility area

Additional areas should be provided for cage repairing and for cleaning and disinfecting such equipment as feed hoppers, watering equipment and nest boxes.

(h) For manure storage, see Sentence 2.2.6.1.(1).

## SUBSECTION 2.1.2. PLANT PRODUCTION

### 2.1.2.1. Greenhouses

Greenhouse area requirements for crops to be transplanted should be determined from Table XXII. The required area of greenhouse is affected by such factors as crop variety and weather at the time of planting.

Table XXII

GREENHOUSE AREA REQUIREMENTS PER ACRE OF TRANSPLANTED CROP	
Crop	Required Greenhouse Bed Area, sq ft per acre of transplanted crop
Tobacco flue-cured type and Burley type	100
Tomatoes early	65 – 85
stake	100 – 165
late	8 – 14
Cabbage	50 – 70
Cauliflower	30 – 50
Celery	85 – 100
Cucumber	110 – 150
Eggplant	90 – 120
Lettuce	60 – 70
Muskmelon	40 – 65
Onions, Spanish	47 – 53
Pepper	50 – 60
Watermelon	25 – 50
Column 1	2

## SUBSECTION 2.1.3. PRODUCT STORAGE

This Subsection deals with the dimensions of buildings based on the requirements of the products to be stored (see Appendix F, Table F-II for unit weights of various agricultural materials).

### 2.1.3.1. Corn Storage in Cribs

(1) For natural wind drying of cob corn in storage, the effective storage width at the base of a rectangular crib should not exceed 5 ft.

(2) For circular cribs greater than 5 ft in diameter, a vertical centre duct of 2 ft is required, and the maximum space between the centre duct and the outside of the bin should not exceed 5 ft.

(3) The open area of slatted crib walls should be at least 30 per cent of the total wall.

(4) If openings are horizontal slots, the vertical dimension of the slots should not be over 1½ in.

(5) If openings are vertical slots, the horizontal dimension of the slots should not exceed 2 in.

### **2.1.3.2. Silage**

#### **(1) Horizontal silos**

- (a) For end self-feeding, the vertical dimension of the settled silage should not be over 6 ft. For mechanical unloading the vertical dimension is limited only by the reach of the mechanical unloader.
- (b) The feeding face at floor elevation should be 4 to 5 in. wide per beef cow or steer and 6 to 8 in. wide per dairy cow provided that the cattle have access to the feeding face 24 hr a day.
- (c) The minimum horizontal usage rate of silage in horizontal silos should be 3 in. per day in cool weather and 4 in. per day in warm weather.
- (d) The length of horizontal silo should be based on the usage rate in Clause (c) times the length of feeding period.
- (e) The end area of horizontal silos should be determined by the daily feed requirement, the usage rate and the depth of silage.
- (f) Horizontal silos should face south and the floor should slope south at 1 ft in 100 ft.

#### **(2) Vertical silos**

- (a) Required vertical dimensions of settled silage, high-moisture shelled grain corn, cracked grain corn or ground ear corn in conventional vertical silos should be based on a minimum usage rate of 2 vertical in. per day in cool weather and 3 vertical in. per day in warm weather (see Appendix F, Table F-II for the volume weight of settled silage in horizontal and vertical silos).
- (b) The total wall height of a vertical silo should be determined from the required depth of settled silage, plus 10 per cent to allow for settling if refilled once, and plus an additional 5 ft if a mechanical top-unloader is suspended in the silo at time of filling.

### **2.1.3.3. Horticultural Crop Storage**

(1) Space requirements for fruit and vegetable storages should be based on the values for apparent bulk density given in Table F-II (Appendix F) with the following adjustments:

- (a) Approximately 5 per cent should be added to compensate for partitions in bulk storage.
- (b) Approximately 20 per cent should be added to compensate for space occupied by containers in pallet box storage.
- (c) Minimum ceiling should be the height of the stored produce, plus 2 ft to allow for air circulation.
- (d) The height of bulk-stored potatoes should not exceed 20 ft.

## **SUBSECTION 2.1.4. SERVICE**

### **2.1.4.1. Vehicle and Equipment Storage**

(1) Total floor area requirements for storage of farm vehicles and equipment should be calculated by summing the "occupied areas" of all machines and vehicles for a given farm enterprise, plus 20 per cent for parking clearance. Occupied areas of typical farm machines are listed in Appendix G.

(2) Door openings should be at least 12 in. wider and 4 in. higher than machine transport dimensions as given in Table G-I, Appendix G.

(3) Where doors or other accesses are from one side only, the depth of storage should not be over 32 ft.

2.1.4.1.

(4) Where doors are at ends only, the span of the building should be 2.5 times the door width as given in Sentence 2.1.4.1.(2).

(5) Where the maintenance shop area can be used for vehicle storage, and where this area meets the requirements of Article 2.1.4.2., up to 50 per cent of the maintenance shop floor area may be counted as storage area for self-propelled farm equipment and vehicles.

2.1.4.2. Maintenance Shops

(1) The maintenance shop floor area should be not less than 20 per cent of the area indicated for vehicle and equipment storage, should be not less than 400 sq ft and should have a minimum horizontal inside dimension of 16 ft free of columns.

## SECTION 2.2 ENVIRONMENTAL SERVICES

### SUBSECTION 2.2.1. TEMPERATURE AND HUMIDITY

2.2.1.1.(1) The operating temperatures and relative humidities for animal production buildings should be maintained within the limits shown in Table XXIII. For effect of temperature on performance, see Appendix I.

Table XXIII

RECOMMENDED TEMPERATURE AND HUMIDITY LIMITS FOR CLOSED ANIMAL PRODUCTION BUILDINGS <sup>(1)</sup>				
Class of Animal	Recommended Inside Temp., °F <sup>(2)</sup>		Recommended Inside Relative Humidity, per cent	
	Min.	Max.	Min.	Max.
Dairy cattle				
cows	20	75	25	75
calves	50	80	25	75
calves over 6 weeks	0	80		
	(if draft-free)			
Beef cattle	0	80	25	75
Sheep and goats	0	80	50	75
Swine				
breeders	45	70	50	75
finishers	60	70	50	75
piglets	70	90	50	75
Poultry				
chicks (1 week)	85	95	50	75
hens	20	85	50	75
turkeys	50	70	50	75
Rabbits	20	85	50	75
Horses	20	85	25	75
Column 1	2	3	4	5

Notes to Table XXIII:

<sup>(1)</sup> Sainsbury, D., 1967 (see Bibliography).

<sup>(2)</sup> Lower temperatures may be tolerated but usually result in increased feed consumption. At temperatures below 32°F, freezing of services must be prevented.

2.2.1.1.

(2) Recommendations for environmental conditions and expected storage life for fruits, vegetables and eggs are shown in Table XXIV. These values do not necessarily apply to controlled atmosphere storage.

Table XXIV

STORAGE LIFE EXPECTANCIES, RECOMMENDED STORAGE TEMPERATURES AND RELATIVE HUMIDITIES AND THE HIGHEST FREEZING POINTS OF FRUITS, VEGETABLES AND EGGS				
Fruits, Vegetables and Eggs	Temperature, °F	Relative Humidity, per cent	Approximate Length of Storage Period	Highest Freezing Point, °F
Apples (for CA storage, see Table XXV)	30 to 32	85 to 95	2 weeks to 7 months depending on variety	28.9
Apricots	31 to 32	85 to 90	1 to 2 weeks	30.1
Blackberries	31 to 32	85 to 90	few days	30.5
Blueberries	31 to 32	85 to 90	3 to 6 weeks	29.0
Cherries sweet	31 to 32	85 to 90	10 days to 2 weeks	28.8
sour	31 to 32	85 to 90	few days	29.0
Cranberries	36 to 40	80 to 85	3 months	30.4
Grapes (American)	31 to 32	85 to 90	4 weeks	29.7
Peaches	31 to 32	85 to 90	2 weeks	30.3
Pears Bartlett	30 to 31	85 to 90	2 to 3 months	28.6
fall and winter varieties	30 to 31	85 to 90	2 to 6 months depending on variety	29.2
Plums including prunes	31 to 32	85 to 90	Prunes 4 to 6 weeks Plums 2 to 4 weeks depending on variety	29.7
Raspberries	31 to 32	85 to 90	few days	30.0
Strawberries	31 to 32	85 to 90	5 to 10 days	30.6
Asparagus	32	95	3 weeks	30.9
Beans green or snap	45 to 50	85 to 90	8 to 10 days	30.7
lima				
shelled	32	85 to 90	2 weeks	31.0
unshelled	32	85 to 90	2 weeks	30.9
Beets bunched	32	90 to 95	10 to 14 days	31.3 (tops)
topped	32	90 to 95	1 to 3 months	30.3
Broccoli (Italian or sprouting)	32	90 to 95	1 week	30.9
Brussels sprouts	32	90 to 95	3 to 4 weeks	30.5
Column 1	2	3	4	5



## 2.2.1.1.(2)

Table XXIV (Cont'd)

Fruits, Vegetables and Eggs	Temperature, °F	Relative Humidity, per cent	Approximate Length of Storage Period	Highest Freezing Point, °F
Cabbage				
early	32	90 to 95	3 to 4 weeks	30.4
late	32	90 to 95	3 to 4 months	31.7
Carrots				
bunched	32 to 34	95	2 weeks	
topped	32 to 34	95	4 to 5 months	29.5
Cauliflower	32	90 to 95	2 weeks	30.6
Celery	33	95+	3 months	31.6
Corn, sweet	32	90 to 95	8 days	30.9
Cucumbers	45 to 50	95	10 to 14 days	31.1
Eggplants	45 to 50	85 to 90	10 days	30.6
Endive or escarole	32	90 to 95	2 to 3 weeks	31.4
Garlic, dry	32	70 to 75	6 to 8 months	30.5
Horseradish	30 to 32	90 to 95	10 to 12 months	28.7
Kohlrabi	32	90 to 95	2 to 4 weeks	30.2
Leeks, green	32	90 to 95	1 to 3 months	30.7
Lettuce	32	95	Head lettuce 2 to 3 weeks	31.7
Melons or cantaloupe				
muskmelon	32 and 45	85 to 90	2 weeks	30.5
honeydew	45 to 50	85 to 90	2 to 3 weeks	30.1
watermelons	36 to 40	85 to 90	2 to 3 weeks	31.3
Mushrooms,				
cultivated	32	85 to 90	5 days	30.4
Onion sets	32	70 to 75	5 to 7 months	
Onions, dry	32	50 to 70	5 to 9 months	30.4
Parsnips	32	95	2 to 4 months	30.4
Peas, green	32	95	1 to 2 weeks	29.9
Peppers, sweet	45 to 50	85 to 90	8 to 10 days	30.7
Potatoes, early				
1. Table	50	90 to 95	few days to several weeks	30.3
2. Processing	60 to 70	90 to 95	few days to several weeks	30.3
Potatoes, late				
1. Table <sup>(1)</sup>	45 to 50	90 to 95	4 to 9 months depending on variety	30.3
2. Seed	36 to 38	90 to 95	7 to 8 months	30.3
3. Chips <sup>(1)</sup>	50	90 to 95	8 to 10 months	30.3
4. French fries	40 to 45	90 to 95	8 to 10 months	30.3
Pumpkins	44 to 50	70 to 75	2 to 3 months	30.5
Radish				
spring, bunched	32	90 to 95	2 weeks	31.3
winter	32	90 to 95	2 to 4 months	30.7
Rhubarb	32	90 to 95	2 to 3 weeks	30.3
Rutabaga or turnip	32	90 to 95	6 months	30.1
Column 1	2	3	4	5

## 2.2.1.1.(2)

Table XXIV (Cont'd)

Fruits, Vegetables and Eggs	Temperature, °F	Relative Humidity, per cent	Approximate Length of Storage Period	Highest Freezing Point, °F
Salsify	32	90 to 95	2 to 4 months	30.4
Spinach	32	90 to 95	10 to 14 days	31.5
Squash				
summer	44 to 50	70 to 75	2 weeks	31.1
winter	44 to 50	70 to 75	6 months	30.7
Sweet potatoes				30.1
Tomatoes				
ripe	50	85 to 90	3 to 5 days	31.1
mature green	55 to 60	85 to 90	2 to 6 weeks	30.5
Eggs	50 to 60	60 to 65		
Column 1	2	3	4	5

**Note to Table XXIV:**

(1) Plus sprout inhibitor.

(3) Apples held in controlled atmosphere storage should be stored under conditions of temperature and gaseous concentrations shown in Table XXV.

Table XXV

CONTROLLED ATMOSPHERE STORAGE REQUIREMENTS FOR SOME VARIETIES OF APPLES <sup>(1)</sup>					
Variety	Storage Temperature		Carbon Dioxide, per cent	Oxygen, per cent	Storage Relative Humidity, per cent
	Min. °F	Max. °F			
McIntosh	35	38	5	3	95
Delicious	30	32	2.5	3	95
Golden Delicious	32	—	2.5	3	95
Rome Beauty	32	—	2.5	3	95
Northern Spy	32	35	5	3	95
Winesap	32	—	5	3	95
Spartan	30	—	2.5	3	95
Newton	35	—	3	3	95
Jonathan	32	—	4	3	95
Baldwin	32	—	2.5	3	95
Macoun	38	—	5	3	95
Column 1	2	3	4	5	6

**Note to Table XXV:**

(1) Handbook on the storage of fruits and vegetables, Canada Dept. of Agriculture, 1967 (see Bibliography).

(4) The removal of field heat should be accomplished in the shortest time possible to adjust to recommended storage temperature, with the exception of potatoes which should be allowed to suberize (to heal) at higher temperatures.

### **2.2.1.1.**

(5) Building surfaces should be provided with sufficient insulation and/or air circulation to prevent condensation under the outside design temperatures and recommended inside humidities.

## **SUBSECTION 2.2.2. VENTILATION**

This Subsection deals with the movement of air within farm buildings for the control of temperature, humidity and air contaminants.

### **2.2.2.1. General**

(1) The outside winter design temperatures for ventilating should be determined on a 5 per cent basis (see Figure 1-H, Appendix H for map of Canada showing January design temperature).

Winter design temperature (5 per cent basis) is the temperature value expressed in degrees Fahrenheit at or below which 5 per cent of the January hourly outdoor temperatures occur.

(2) Inside design temperatures for product storage should be based on Table XXIV.

(3) Inside design temperatures for livestock should be based on optimum conditions indicated in Appendix I.

(4) Ventilation requirements for livestock structures should be based on the inside-outside temperature differentials and the heat and moisture production relationship of the livestock. (See Appendix I, Tables I-IV.)

(5) Ventilation requirements for fruit and vegetable storage should be based on the inside-outside temperature differentials, field heat and heat of respiration of stored products. (See Appendix J.)

(6) Greenhouse ventilation systems should be capable of providing 15 air changes per hour for spring and fall weather conditions. For summer conditions greenhouses should be provided with 10 cfm per square foot of greenhouse floor area plus evaporative cooling.

(7) Except when mechanical ventilation is provided, natural ventilation should be provided by means of openable windows, flues, shutters or louvres.

### **2.2.2.2. Ventilation Systems**

(1) All ventilating equipment should be approved, all motors totally enclosed, thermally protected and installed in accordance with the provincial electrical inspection authority.

(2) Design of ducts, air inlets, grilles, fans and power units should be carried out in accordance with good engineering practice. (See Figures 1-K and 2-K, Appendix K for resistance of grains and seeds to air flow.)

(3) Exhaust fans that are not connected to a duct system should be selected on the basis of delivery at not less than ½-in. water static pressure.

(4) A warning device should be installed in the system to detect ventilation failure.

(5) Shutters should be provided on exhaust fans.

(6) Where wind conditions dictate, exhaust fans installed in walls should be hooded to 6 in. below their bases.

(7) Thermostats and other fan controllers should be located in an area free of potential mechanical damage, and so placed that they will sense average ambient conditions.

(8) Fresh air inlets should be arranged to prevent direct drafts on livestock in winter.

(9) Fresh air inlets should be shielded from snow and rain and should be fitted with a corrosion-resistant screen of ½ in. square mesh.

#### **2.2.2.2.**

(10) Fresh air inlets should be separated from exhaust fans by at least 10 ft. Inlets should be located to provide even distribution of fresh air to all parts of the building.

(11) For machine repair shops, see Sentence 1.2.5.9.(2).

(12) Where natural daylight must be excluded from animal buildings, ventilation openings should be fitted with baffles painted flat black. Such baffles should be arranged to provide at least 2 light reflections for inlet openings and 3 light reflections for exhaust openings.

### **SUBSECTION 2.2.3. HEATING AND REFRIGERATION SYSTEMS**

#### **2.2.3.1. General**

For approval and installation specifications for heating and refrigeration equipment see Sentence 1.2.2.1.(1).

#### **2.2.3.2. Heating Systems**

(1) In accordance with Subsection 2.3.4., sufficient insulation should be provided in walls and ceilings of farm buildings (except greenhouses) to permit the maintenance of recommended minimum inside temperatures and to prevent condensation. Where this is not feasible, supplemental heat should be provided.

(2) Except for CO<sub>2</sub> controlled atmospheres, when fuels are burned in greenhouses, fresh air inlets should be provided at the rate of 50 sq in for every 100,000 Btu of fuel input.

#### **2.2.3.3. Refrigeration Systems**

The size of refrigeration systems and equipment for fruit and vegetable storage should be determined on the basis of heat of respiration, field heat (at time of harvest) and desired cooling rate, heat gain and losses from other sources and relative humidity.

### **SUBSECTION 2.2.4. ELECTRICAL SERVICES**

#### **2.2.4.1. General**

All buildings should be served from a stepdown transformer located centrally in relation to the electrical loading.

#### **2.2.4.2. For size of service wire see Article 1.2.3.2.**

#### **2.2.4.3. Three-Phase Power**

In areas where 3-phase power is not readily available, 3-phase motors from 7.5 to 100 horsepower may be supplied by means of a phase convertor. "*Phase convertor*" means a device that will permit the operation of a 3-phase induction motor from a single-phase power source. Consult power supply authority as to size allowed in a particular location.

#### **2.2.4.4. Isolated Motors and Electrical Equipment**

Motors and electrical equipment located a considerable distance from the farm buildings may be served by a separate service or by a circuit from the farm service. Consult the power supply authority for recommendations.

#### **2.2.4.5. General Requirements for Lighting and Cable Heating**

(1) Minimum recommended lighting levels for human tasks are shown in Table L-VI, Appendix L. Lighting recommendations in Subsection 2.2.4. are based on incandescent lamps. Fluorescent or other vapour type lighting can be substituted where applicable. Fluorescent lighting is not recommended in high humidity or cold environments or where light dimming is required.

(2) Cable heating recommendations in this Subsection are based on density in watts per sq ft. (See Article 1.2.3.12. and Table L-VII and Figure 1-L, Appendix L.)

#### 2.2.4.6. Branch Circuits

##### (1) Types of circuits

- (a) *“General use branch circuit” means that portion of the wiring system extending from the final fuse or circuit breaker to the outlets such as lighting and general purpose convenience outlets. Table L-I in Appendix L should be used for design, with load based on ¾ ampere per outlet.*
- (b) *“Individual use branch circuit” means a circuit installed to supply individual equipment such as a motor, ½-horsepower or over, a stationary appliance of 1000 watts or over, poultry brooders and heating equipment. Special and individual use circuits should be designed in accordance with Article 1.2.3.2. No. 12 AWG copper wire is the recommended minimum size for individual or special circuits.*

#### 2.2.4.7. Warning Systems

(1) Buildings housing animals at high-housing densities or other structures containing living materials of high risk may be equipped with an electrical warning system to indicate in the farm residence any or all of the following undesirable conditions:

- (a) fire,
- (b) undesirably high or low temperature,
- (c) low water pressure,
- (d) electrical supply interruption, and
- (e) intruders.

(2) An intercommunication system by which distressed animals can be heard in the residence can be an integral part of the warning system.

#### 2.2.4.8. Dairy Structure

##### (1) Tie stall dairy barns

###### (a) Lighting outlets

(i) Litter alleys — for face-out arrangement lighting outlets should be placed along the centre line of the litter alley, one outlet directly behind every other stall divider. For wide litter alleys two rows of outlets 12 in. to the rear of each gutter line should be used, locating outlets alternately across the alley.

For face-in arrangement lighting outlets should be placed about 12 in. to the rear of the gutter line, directly behind every other stall divider.

(ii) One outlet should be provided every 10 to 12 ft of feed alley.

(iii) One ceiling outlet should be provided for each bull, maternity or calf pen (100 sq ft or larger). Individual wall switch control should be provided outside the pen.

###### (b) Convenience outlets

(i) A convenience outlet should be installed at least every 50 ft along litter alleys. These outlets may be on outside walls where cows face in and on structural posts where cows face out.

(ii) One outlet should be provided out of reach of animals for each maternity pen. Where pens have low partitions, 1 outlet may be located to serve 2 pens.

###### (c) Special-purpose outlets

(i) Circuits using wire not less than No. 12 AWG should be provided for vacuum pumps for milking machines, refrigeration compressors and feed handling equipment.

(ii) Circuits should be provided for gutter cleaners. The circuit wire size, based on the motor horsepower, should be selected from Table L-III in Appendix L.

#### **2.2.4.8(1)(c)**

(iii) Ventilating fans (see Article 1.2.3.9).

#### **(2) Loose housing dairy barns**

(a) Lighting outlets

(i) In pens with open fronts 1 lighting outlet should be provided for every 400 sq ft. In closed pens 1 lighting outlet should be provided for every 200 sq ft.

(b) Convenience outlets

(i) One outlet should be provided at each location where equipment such as clippers, groomers, immersion heaters, etc. can be used conveniently.

(ii) An outlet on an inside wall should be provided near each major entrance.

(iii) One outlet out-of-reach of animals should be provided for each maternity pen. Additional outlets should be provided in calf pen areas.

(c) Special-purpose outlets

(i) Where water systems need protection against freezing, provision should be made for heating cable or other heating devices or circuits for heated water bowls.

(ii) Separate outlets should be provided for feed handling equipment.

#### **(3) Free stall barns**

(a) Lighting outlets

Lighting outlets should be provided over passageways 12 ft on centre and as required to facilitate chores. Lighting outlets should be installed over feed bunks 12 ft on centre. Every third light should be controlled in a separate group for all-night feeding.

(b) Convenience outlets

(i) One outlet should be installed on an inside wall near each major entrance, 6 ft above the floor.

(ii) An outlet should be provided for clippers and veterinary equipment in the treatment area.

(c) Special-purpose outlets

(i) A circuit for electrically-heated automatic watering equipment should be provided in areas where freezing is apt to occur.

(ii) Individual circuits should be provided for feeding equipment.

(iii) Circuits may be required for a gutter cleaner and liquid manure pump.

(iv) Circuits should be provided to serve heating equipment such as heating cable in the pit floor, the infra red or fan-forced units as required.

(v) Circuits should be provided for vacuum pumps.

#### **(4) Milking parlour**

(a) Lighting outlets

(i) One outlet should be provided over the milking pit opposite the rear of each cow on the centre line of the pit, or a minimum of 1 outlet should be provided for each 36 sq ft of working area.

(ii) One outlet should be provided at each entrance and exit of cow passageways.

(b) Convenience outlets

One outlet at each end of the operator's pit should be provided.

#### **2.2.4.8.(4)**

(c) Electric heating

(i) Separate radiant heater or heat lamps may be installed over work areas for operator comfort.

(ii) Cable heating (see Sentence 2.2.4.5.(2)).

**(5) Milkhouses**

(a) Lighting outlets

(i) One outlet should be placed in the ceiling and 1 or 2 outlets over each work area for bulk milk tanks (see Subclause 1.3.3.1.(3)(h)(ii)).

(ii) A minimum of 2 watts per per square foot (incandescent) of floor area should be provided.

(b) Convenience outlets

(i) One outlet should be provided for each work area.

(ii) The outlets should be placed high enough to escape being splashed.

(c) Special-purpose outlets

230-volt individual circuits should be provided for

(i) water heaters,

(ii) milkroom heaters (if electrical),

(iii) coolers,

(iv) vacuum pumps (milker), and

(v) tank truck pump outlets, if required (to be located on the outside wall near the hose port and to be controlled by a switch on the inside near the bulk tank truck outlet).

(d) Electric heating (if used)

(i) One "fan type" permanently installed heater with thermostat control should be provided.

(ii) A separate radiant heater or heat lamps may be installed over the wash-up area for operator comfort.

(iii) Electric cable heating (see Sentence 2.2.4.5.(2)).

(e) Ventilating fans (see Article 1.2.3.9.).

#### **2.2.4.9. Beef Cattle Structure**

**(1) Beef barns**

(a) Lighting outlets to be provided should include:

(i) one outlet for every 400 sq ft of open front pen area and 1 outlet for every 200 sq ft of closed pen area,

(ii) one outlet for every 100 sq ft in feed rooms and power equipment control areas,

(iii) One outlet over maternity and bull pens and 1 outlet with wall-switch control outside the pens,

(iv) outlets over feed bunks and feeding areas on 15-ft centres with every third outlet separately switched as a group for all night feeding as required, and

(v) one outlet over each automatic waterer for all night use.

#### **2.2.4.9.(1)**

- (b) Convenience outlets  
An outlet should be provided in the treatment area.
- (c) Special-purpose outlets should be provided for
  - (i) feed-handling equipment, concentrate conveyors and bale elevators, and
  - (ii) automatic livestock water bowls having electrical frost protection.

#### **2.2.4.10. Horse Structures**

##### **(1) Horse stables (tie stalls)**

- (a) Lighting outlets
  - (i) One outlet should be provided at the rear of every other tie stall on the centre line of the alley.
  - (ii) One outlet should be provided for every 16 ft on the centre line of the feed alley.
  - (iii) One outlet should be provided for each feed room and box stall.
- (b) Convenience outlets
  - (i) One outlet should be provided at the rear of every other tie stall.
  - (ii) In barns having a centre litter alley, 1 outlet will serve 2 to 4 stalls depending upon the structure.
  - (iii) Ventilating fans (see Article 1.2.3.9.).
  - (iv) Two outlets should be provided for each harness room and feed room.

##### **(2) Horse stables (box stalls)**

- (a) Lighting outlets
  - (i) One outlet should be provided every 16 ft on the centre line of feed alleys.
  - (ii) One outlet should be provided for each box stall.
  - (iii) One outlet should be provided for each harness room and feed room.
- (b) Convenience outlets
  - (i) Outlets should be provided in the feed alley so that one serves every 4 stalls.
  - (ii) Ventilating fans (see Article 1.2.3.9.).
  - (iii) One outlet should be provided for each harness room and feed room.
- (c) Special-purpose outlets
  - (i) A special outlet should be provided, if required, for an oat crusher or roller mill in a feed room or feed cooker.

#### **2.2.4.11. Sheep Structures**

##### **(1) Sheep barns and lambing sheds**

- (a) Lighting outlets  
One outlet should be provided for every 16 ft on the centre line of feed alleys.
- (b) Convenience outlets
  - (i) One outlet should be provided for each pair of pens for heat lamps.
  - (ii) An outlet for sheep shearers should be provided on the wall or post at the location where shearing is done.



#### **2.2.4.11.(1)(b)**

- (iii) Ventilating fans (see Article 1.2.3.9.).
- (c) Special-purpose outlets
  - (i) Outlets should be provided for automatic livestock water bowls having electrical frost protection.

#### **2.2.4.12. Hog Structures**

##### **(1) Farrowing barns**

- (a) Lighting outlets
  - (i) An outlet should be provided over every other pen partition or over the centre line of the farrowing crate on 10-ft centres.
  - (ii) One outlet should be provided for each 100 sq ft of feed, isolation and wash areas.
- (b) Convenience outlets
  - (i) One outlet should be provided over the creep area for each pen or farrowing crate, or 1 duplex outlet centred over the partition dividing 2 adjacent creep areas. For farrowing pens with the creep at the head an additional outlet should be provided over the rear of the pen.
    - (ii) One outlet should be located on the inside wall at each main entrance.
    - (iii) One outlet should be provided in the wash area.
- (c) Special-purpose outlets
  - (i) Circuits should be provided for each heating cable and space heaters, if electric, as required (see Sentence 2.2.4.5.(2)).
  - (ii) An outlet should be provided for a water heater, if electric.
  - (iii) Ventilating fans (see Article 1.2.3.9.).

##### **(2) Hog finishing barns**

- (a) Lighting outlets
  - (i) One outlet should be provided for every 2 pens or 200 sq ft of floor area.
  - (ii) One outlet should be provided for each 100 sq ft of feed preparation area and isolation area.
- (b) Convenience outlets
  - (i) One outlet should be provided on the inside wall beside each main entrance.
  - (ii) One outlet should be provided in the isolation area for heat lamp use.
- (c) Special-purpose outlets
  - (i) A circuit should be provided for feed-handling equipment.
  - (ii) Circuits should be provided for floor heat if required (see Sentence 2.2.4.5.(2)).
  - (iii) Ventilation fans (see Article 1.2.3.9.).

#### **2.2.4.13. Poultry Structures**

##### **(1) Laying houses**

- (a) Lighting outlets
  - (i) Birds on litter, slats or wire

Ceiling outlets should be installed 12 ft on centre. In addition, a 10-watt dim-light outlet should be provided for each 400 sq ft of floor area on a separate circuit, in a row, slightly

#### 2.2.4.13.(1)(a)

back of the bright light outlets towards the roosts. Both bright and dim-light outlets should be controlled by wall switches and time clocks.

##### (ii) Birds in cages

Outlets should be provided every 12 ft on the centre line of aisles between double-tier cages and every 10 ft on the centre line of aisles between triple-tier cages controlled by wall switches and a time clock.

(iii) One outlet should be provided for every 100 sq ft of feed and preparation area.

#### (b) Convenience outlet

##### (i) Floor housing

Outlets should be provided at 100-ft intervals around the perimeter of the building and beside each main entrance.

##### (ii) Cage housing

Outlets should be provided over each alley at 100-ft intervals.

#### (c) Special-purpose outlets

(i) Where a mechanized system is to be installed, circuits should be provided for:

feed conveying and automatic feeders,  
pit or gutter cleaners, and  
egg gathering systems.

(ii) An outlet should be provided for a water heater (if electric).

(iii) Ventilating fans (see Article 1.2.3.9.).

## (2) Brooder houses

#### (a) Lighting outlets

##### (i) Broiler houses

Outlets should be provided 12 ft on centre controlled by wall switches and a time clock. If a variable level of lighting is desired, a rheostat control should be provided in addition to the wall switches and time clock.

##### (ii) Started pullets

Outlets should be provided 12 ft on centre, controlled by wall switches and a time clock. If a variable level of lighting is desired, additional controls in addition to the wall switches and time clock should be provided.

(iii) One outlet should be provided for each 100 sq ft of feed room and service area.

#### (b) Convenience outlets

##### (i) Floor brooding

Outlets should be provided at 100-ft intervals around the perimeter of the building and beside the main entrances and loading doors.

##### (ii) Cage brooding

Outlets should be provided over each alley at 100-ft intervals.

#### (c) Special-purpose outlets

(i) Outlets should be provided for feed conveying and automatic feeding equipment.

(ii) For electric brooding, outlets should be provided having a capacity of approximately 3 watts per square foot of floor area.

(iii) Ventilating fans (see Article 1.2.3.9.).

### 2.2.4.13.

#### (3) Egg-storage and handling rooms

##### (a) Lighting outlets

(i) One outlet should be provided for every 100 sq ft of floor area.

(ii) Two outlets should be provided over each work area if incandescent lighting units are used, or 1 outlet if fluorescent units are used.

##### (b) Special-purpose outlets

(i) Outlets should be provided for egg candler, egg washers, graders, conveyors, vacuum pumps, refrigeration and heating equipment.

(ii) An outlet for each water heater should be provided if electric.

### 2.2.4.14. Field Crop Structures

#### (1) Feed-grinding rooms

##### (a) Lighting outlets

(i) One outlet should be provided for every 100 sq ft of floor area.

(ii) Outlets should be provided over work areas where required.

(iii) Fixtures should be dustproof, and the switch should also be dustproof unless mounted outside the room.

##### (b) Special-purpose outlets

Outlets should be provided for feed grinders and for feed mixers.

#### (2) Grain and feed storage

##### (a) Lighting outlets

(i) One outlet should be provided for every 400 sq ft of floor area.

(ii) Dustproof fixtures should be used, and the switch should also be dustproof unless mounted outside the room.

##### (b) Convenience outlets

Outlets should be provided for grain aerators, augers and elevators as required.

##### (c) Special-purpose outlets

Outlets should be provided where corn or grain driers or elevators are used.

#### (3) Mow areas

##### (a) Lighting outlets

(i) One outlet should be provided for every 1000 sq ft of floor area.

(ii) Fixtures should be dustproof.

(iii) Outlets should be located near the peak of the roof so that hay chutes and ladders are well lighted.

##### (b) Convenience outlets

An outlet should be provided beside each main doorway and each filling door for use with elevators.

##### (c) Special-purpose outlets

Outlets should be provided as required for equipment such as hay dryers.

#### **2.2.4.14.**

##### **(4) Silos**

###### **(a) Lighting outlets**

(i) Two outlets should be provided, one on the ceiling of the silo and the other at the top of the chute, wall switch controlled at the foot of the chute or at the entrance to the tunnel leading to the chute.

(ii) Outlets should be placed so that they can be reached from the top of the chute ladder for cleaning and lamp replacement.

###### **(b) Convenience outlets**

Outlets should be provided, if required, for self-unloading wagons.

###### **(c) Special-purpose outlets**

A circuit should be provided for a silo unloader. A circuit for an ammeter should be included to regulate the load on the unloader. A safety device should be provided to permit locking out the ground level control switch for protection of the operator while he is in the silo. An electrical control station to permit the use of a manual hold-in switch in the silo for unloader operation during maintenance is highly recommended.

##### **(5) Tobacco stripping rooms**

###### **(a) Lighting outlets**

Fluorescent outlets consisting of either a 4-lamp fixture (3 daylight, 1 deluxe warm white) or a 2-lamp fixture (1 daylight, 1 deluxe cool white) should be mounted 5 to 7 ft over the front edge of the stripping bench.

##### **(6) Tobacco barns (Burley)**

###### **(a) Lighting outlets**

Outlets should be provided every 12 ft on posts on the side of the driveway.

#### **2.2.4.15. Fruit and Vegetable Crop Structures**

##### **(1) Fruit and vegetable storage**

###### **(a) Lighting outlets**

One outlet should be provided for every 300 sq ft of floor area, except in bulk potato storages where 1 outlet with a reflector for indirect lighting should be provided 16 ft on centre over alleyways.

###### **(b) Convenience outlets**

Outlets should be provided for the use of supplementary lighting or portable equipment.

###### **(c) Special-purpose outlets**

Circuits should be provided for refrigeration, ventilation, heating and other equipment as required.

##### **(2) Sorting, grading, washing and packing rooms**

###### **(a) Lighting outlets**

(i) An outlet should be provided for every 100 sq ft of floor area.

(ii) One outlet should be provided for each 5 linear feet of machine such as washers, graders, conveyors, etc., with local wall switch control for each outlet or group of outlets.

##### **(3) Greenhouses**

###### **(a) Lighting outlets**

(i) One outlet should be provided for every 16 ft through the centre of the house.

#### **2.2.4.15.(3)(a)**

- (ii) One outlet should be provided over each work bench in the head house with a minimum of 1 outlet for every 5 ft of work bench.
- (iii) Boiler rooms should be provided with 1 or more lighting outlets.
- (b) Special-purpose outlets
  - (i) Outlets for soil heating, pasteurization and sterilization should be provided where required.
  - (ii) Outlets should be provided for portable spray pumps.

#### **2.2.4.16. Farm Workshops and Machinery Sheds**

##### **(1) Farm workshops**

- (a) Lighting outlets
  - (i) One outlet should be provided for every 200 sq ft of floor area.
  - (ii) One outlet should be provided for each permanently placed piece of equipment, or at least 1 outlet for each 10 ft of bench length.
- (b) Convenience outlets
  - (i) One outlet should be provided for each 5 ft of bench length.
  - (ii) A weatherproof outlet should be provided on the exterior of the building near the doorway.
- (c) Special-purpose outlets.
  - (i) Outlets should be provided for local comfort heaters.
  - (ii) One outlet should be provided for each permanently placed piece of equipment.
  - (iii) Local power supply authorities should be consulted concerning installation of electric welders.

##### **(2) Machinery sheds**

- (a) Lighting outlets  
One outlet should be provided for every 400 sq ft of floor area.
- (b) Convenience outlets  
One outlet should be mounted 5 ft above the floor for every 40 ft of perimeter for use with trouble lamps, portable drills, etc.

#### **2.2.4.17. Water Supply**

##### **(1) Lighting outlets**

One outlet should be provided over the pump.

##### **(2) Convenience outlets**

One outlet should be provided near the pump for portable equipment such as drills, trouble lamps or heaters.

##### **(3) Special-purpose outlets**

- (a) An outlet on a separate circuit should be provided for each pump motor.
- (b) Outlets for the pump should be equipped with a disconnect switch for use when servicing the pump.
- (c) If the pump motor is not equipped with a thermal overload device, motor overload protection should be supplied in the circuit.

**2.2.4.17.(3)**

(d) Where 2 or more pumps are located adjacent to one another, the pump motors may be supplied on 1 special feeder, terminating in separate motor disconnecting switches equipped with branch circuit protection as well as with motor running overcurrent protection.

**(4) Grounding**

(a) The pump motor should be properly grounded. See Article 1.2.3.11. (plastic pipe or other non-conductive material is not adequate for grounding).

**(5) Water for fire protection (see Clause 2.2.5.1.(3)(d)).**

**2.2.4.18. Exterior Lighting**

**(1) Lighting outlets**

(a) At least 1 yard light and lights over the main doorways of animal buildings should be provided.

(b) Yard lights should be on a separate circuit.

(c) Multiple switch control from 2 or more points with 3- and 4-way switches should be provided.

(d) Security lighting should be provided as required.

**2.2.4.19. Rabbit Structures**

**(1) Lighting outlets**

(a) Outlets should be provided every 12 ft on the centre line of feed passages.

(b) One outlet should be provided for every 100 sq ft of floor area of feed preparation and utility areas.

**(2) Convenience outlets**

(a) One outlet should be provided over each passageway at 100-ft intervals and beside the main entrance.

**SUBSECTION 2.2.5. WATER SUPPLY**

**2.2.5.1. Water Quantities**

**(1) Water consumption**

(a) For optimum water consumption by animals the water should be available at a temperature of 50°F and in the quantities given in Table XXVI.

**Table XXVI**

<b>DAILY WATER REQUIREMENTS OF ANIMALS</b>	
<b>Class of Animal</b>	<b>Daily Water Requirements, gal. (U.S.)</b>
Milk cow	35
Beef or dry cow	15
Horse	15
Hog	2
Sheep	2
100 Laying hens	10
100 Turkeys	18
Column 1	2

### 2.2.5.1.(1)

(b) Watering facilities in loose housing and other unheated structures should be protected against freezing by the use of approved frostproof automatic electric water bowls, heated tanks or frostproof hydrants.

#### (2) Water for cleaning purposes

(a) Cold water

Water should be available at a minimum rate of 200 gal. (U.S.) per hr and a minimum pressure of 30 psi for washing floors of milking parlours, milk rooms, livestock pens and poultry houses.

(b) Hot water for dairy barns

(i) Hot water heaters should provide hot water at a temperature of 160°F and should be equipped with a reliable thermometer installed in the delivery pipe.

(ii) Hot water heaters should have recovery rates capable of restoring the full hot water requirements during periods between milkings.

(iii) For pail milker systems in tie stall barns, hot water heater capacities should be 20 gal. (Can.) for herds of 20 milking cows or less and 40 gal. (Can.) for herds of 21 to 75 milking cows. For herds greater than 75 milking cows heater capacities should be based on 0.60 gal. (Can.) per milking cow and the next larger standard-size tank should be selected.

(iv) For portable dumping station and pipeline transfer systems in tie stall barns, hot water heater capacities should be based on 0.25 gal. (Can.) per milking cow plus 0.33 gal. (Can.) per foot of pipeline.<sup>(1)</sup> The next larger standard-size tank should be selected.

(v) For pipeline milking systems in tie stall barns, hot water heater capacities should be based on 0.20 gal. (Can.) per milking cow plus 0.12 gal. (Can.) per foot of pipeline.<sup>(1)</sup> The next larger standard-size tank should be selected.

(vi) For pipeline milking systems in milking parlours, hot water heater capacities should be based on 0.20 gal. (Can.) per milking cow plus 0.63 gal. (Can.) per foot of pipeline.<sup>(1)</sup> The next larger standard-size tank should be selected.

(c) Hot water for poultry buildings

(i) Hot water should be provided for cleaning equipment in service rooms of poultry houses.

(ii) Where egg washing is carried out on the farm, hot water should be available to supply the requirements of the washer used.

(d) Hot water for other uses

Hot water and steam should be available in abattoirs and killing plants.

#### (3) Water for fire protection

(a) Water from any adequate source may be used for fire protection.

(b) To allow the use of community fire fighting equipment, water storage should be

(i) of a minimum capacity of 5000 gal. (U.S.)

(ii) readily accessible, and

(iii) no farther than 500 ft from the major farm structures.

(c) Farm pumps intended for control of fire spread to other buildings should have a minimum capacity of 5 gal. (U.S.) per min. at 30 psi pressure, and if intended for extinguishing fires, the minimum capacity should be 15 gal. (U.S.) per min. at 50 psi pressure.

<sup>(1)</sup> Turner, C.N., 1964 (see Bibliography).

### 2.2.5.1.(3)

- (d) Electric motors on farm pumps used for fire protection should be supplied by an electrical circuit independent of all buildings.

### 2.2.5.2. Design of Water Distribution Systems

#### (1) General

- (a) Water supply pipes and fittings should be of corrosion-resistant material.
- (b) Permanent supply pipes should be laid below frost level. Where the distribution system is exposed to freezing temperatures, protection against freezing should be provided by the use of heating cable or other heating device.

#### (2) Pipe sizes

##### (a) General

Pipe size should be determined on the basis of pipe material, pipe length, flow requirement and minimum outlet pressure requirement.

- (b) Pipe sizes for distribution systems with branching pipes should be determined according to the following:

- (i) The pressure at any outlet should be at least 15 psi and depends on the "start" pressure of the pressure system, the elevation of the outlet and the friction head loss (see Appendix D, Tables D-I to D-IV).

- (ii) The distribution main pipe from the pressure system should be designed for a minimum flow rate of 10 gal. (U.S.) per min. When the pump capacity of the pressure system exceeds 10 gal. (U.S.) per min., the main pipe should be designed for a flow rate at least equal to the pump capacity.

- (iii) Individual branch pipes to single outlets should be designed for the rated flow of the outlets. The branch pipe to a single hose bib should be designed for a flow rate of 5 gal. (U.S.) per min.

### 2.2.5.3. Installation of Water Supply and Distribution Systems

- (1) The water supply and distribution system should be installed in accordance with Part 7 (Plumbing Services) of the National Building Code of Canada 1975.

- (2) All materials used in water supply systems should be of good quality and should comply with the specifications in Part 7 (Plumbing Services) of the National Building Code of Canada 1975.

- (3) Pumps and other devices should be installed in such a manner as to provide protection against contamination and to ensure efficient operation and maintenance.

- (4) When pumps are located in unheated areas, the pump enclosures should be insulated and, if required, heat should be provided.

- (5) Shallow well pumps should not be installed more than 22 ft above the anticipated water level at the time of maximum draw down.

### SUBSECTION 2.2.6. ENVIRONMENTAL PROTECTION

#### 2.2.6.1. Manure Storage

- (1) The design capacity of manure storage facilities should be based on the quantities shown in Table XXVII.

- (2) Sufficient storage capacity should be provided to avoid the necessity of disposal on snow, frozen ground or sensitive crops.



Table XXVII

MANURE STORAGE VOLUMES			
Class of Animal	Manure Production, cu ft/animal-day	Required Storage for Liquid Manure, cu ft/animal-day	Required Storage for Solid Manure Including Bedding, cu ft/animal-day
<b>Cattle</b>			
Beef or dairy calves (0 to 3 months)	0.19	0.19	
Beef or dairy calves (3 to 6 months)	0.25	0.35	
Beef feeders or dairy heifers (6 to 15 months)	0.50	0.70	0.6
Beef feeders or dairy heifers (15 to 24 months)	0.75	1.1	0.8
Beef cows (1200 lb)	1.0	1.4	1.2
Dairy cows (1200 lb)	1.6 <sup>(1)</sup>	2.2	
Open pen loose housing			2.0
Free stall loose housing		2.4	1.7
Tie stall			1.8
<b>Swine</b>			
40-200 lb (8 to 22 weeks)	0.18 <sup>(1)</sup>	0.25	0.25
10-25 lb (3 to 6 weeks)	0.04	0.055	
26-50 lb (6 to 9 weeks)	0.08	0.11	
51-75 lb (9 to 12 weeks)	0.12	0.17	
76-125 lb (12 to 16 weeks)	0.18	0.25	
126-175 lb (16 to 20 weeks)	0.26	0.36	
176-200 lb (20 to 22 weeks)	0.32	0.45	
Sows	0.40 <sup>(1)</sup>	0.56	0.48
<b>Chickens</b>			
Broilers (0 to 4 lb)	0.0028		0.005
Laying hens (5 lb)	0.005		
<b>Turkeys</b>			
Broilers (0 to 14 weeks)	0.0045		
Growing hens (0 to 22 weeks)	0.0065		
Growing toms (0 to 24 weeks)	0.01		
Breeding flocks	0.012		
<b>Mink (female and kits)</b>			
	0.007		
Column 1	2	3	4

### 2.2.6.1.

**Table XXVII (Cont'd)**

Class of Animal	Manure Production cu ft/animal-day	Required Storage for Liquid Manure, cu ft/animal-day	Required Storage for Solid Manure Including Bedding, cu ft/animal-day
Rabbits (doe and litter)	0.025		
Sheep	0.10 <sup>(1)</sup>	0.24	0.15
Horses	0.92 <sup>(1)</sup>		2.0
Column 1	2	3	4

**Note to Table XXVII:**

<sup>(1)</sup> Berglund, S., Aniansson, G. and Ekesbo, I., 1965 (see Bibliography).

### 2.2.6.2. Dead Bird Disposal

- (1) Disposal tank capacities for dead birds should be based on flock size as follows:
- (a) 20 cu ft per 1000 broilers, and
  - (b) 100 cu ft per 1000 layers (see Article 1.3.2.3.).

### 2.2.6.3. Disposal of Milk Centre Wastes

(1) Approval of the disposal system design should be obtained from local authorities. The effluent from lagoons for milk centre wastes may not be of acceptable quality for discharge into a receiving body of water.

(2) **Sediment tank-disposal field systems**

- (a) Capacities of sediment tanks should be as given in Table XXVIII(a). Where milking parlour manure solids are added to the milk centre wastes, sediment tank capacities shown in Table XXVIII(a) should be doubled. This would apply where manure gratings or floor drains under the milking stalls collect the manure, and would not apply where the parlour floor is operated "dry" and solid manure is removed and placed in the manure storage.

**Table XXVIII(a)**

SEDIMENT TANK CAPACITIES FOR MILK CENTRE WASTES				
No. of Cows	Volume, Gal. (Can.)	Settling Compartment		
		Length	Width	Water Depth
Up to 25	500	6 ft 9 in.	3 ft 0 in.	4 ft 0 in.
26 to 45	600	8 ft 0 in.	3 ft 0 in.	4 ft 0 in.
46 to 65	720	9 ft 0 in.	3 ft 3 in.	4 ft 0 in.
66 to 100	900	9 ft 0 in.	3 ft 6 in.	4 ft 6 in.
Column 1	2	3	4	5

- (b) Sediment tanks should be constructed to permit easy inspection and removal of sediment. Cleaning will be required at regular intervals depending upon sanitation and other practices.
- (c) Material removed from sediment tanks should be disposed of in a manner acceptable to local authorities.

### 2.2.6.3.(2)

- (d) Size of the underground disposal field for effluent from sediment tanks should be as given in Table XXVIII(b).

**Table XXVIII(b)**

SIZE OF UNDERGROUND DISPOSAL FIELD FOR MILK CENTRE WASTES			
No of Cows	Length of Tile Trench, ft		
	Subsoil Drainage		
	Good (Sand and Gravel)	Medium (Sandy Loam Soil)	Poor (Silt and Clay Loam Soil)
Up to 25	100	100	150
26 to 45	100	180	270
46 to 65	130	260	390
66 to 100	200	400	600
Column 1	2	3	4

### (3) Lagoons

- (a) Capacities of lagoons should be based on the provision of 50 to 60 sq ft of lagoon surface area per cow milked.
- (b) Lagoons should be constructed in accordance with Sentences 2.2.6.4.(2), (3)(a) and (c), (4), (5) and (6).

### 2.2.6.4. Manure Lagoon (see Article 1.3.2.5.)

(Under many conditions the use of lagoons alone is not a practical method of disposing of animal manure.)

#### (1) Loading rates

- (a) Allowable loading rates for lagoons used for manure disposal depend upon the following factors:
- (i) climatic data including precipitation-evaporation ratio,
  - (ii) proximity to populated areas and water supplies,
  - (iii) effect of effluent on streams, and
  - (iv) local regulations.
- (b) Aerobic lagoons

*“Aerobic lagoon” means a naturally aerated lagoon in which the processing of waste material is achieved in the presence of oxygen.*

(i) Aerobic lagoons may be constructed only in those cases where:  
no other method of manure disposal is available,  
stringent health regulations prohibit the use of anaerobic or  
combined anaerobic-aerobic lagoons, and  
an adequate supply of water is available to dilute the manure.

(ii) Where aerobic lagoons are required, approval of designs should be secured from proper local authorities before construction is begun. Table XXIX should be used to convert loading rates for domestic sewage to agricultural use.

2.2.6.4.(1)

Table XXIX

LOADING RATES FOR AEROBIC LAGOONS <sup>(1)</sup>				
Waste Source	Population Equivalent	Animals per Acre of Lagoon		
Man	1	Domestic Sewage Loading Rates, population/acre <sup>(2)</sup>		
		100	150	200
Cows	16.4	6	9	12
Horses	11.3	9	13	18
Sheep	2.45	40	60	80
Hogs	1.9	52	80	105
Chickens	0.014	7,000	10,500	14,000
Column 1	2	3	4	5

**Notes to Table XXIX:**

<sup>(1)</sup> Eby, H.J., 1963 (see Bibliography).

<sup>(2)</sup> Consult proper local authorities for allowable domestic sewage loading rates.

(c) Anaerobic lagoons

*“Anaerobic lagoon” means a lagoon in which the processing of waste material is achieved in the absence of oxygen. This lagoon is essentially an open cesspool.*

(i) Anaerobic lagoons should be used only where there is adequate space separation from dwellings and neighbouring properties and the prevailing wind direction is such that odours will not create a nuisance.

(ii) The effluent from overflowing anaerobic lagoons should receive further processing by spreading on crop land or by discharging into aerobic lagoons. The effluent may not be of a quality acceptable to local authorities for discharge into a receiving body of water.

(iii) Where anaerobic lagoons are used, approval of designs should be secured from proper local authorities before construction is begun. Table XXX may be used to determine the volume of lagoon required.

Table XXX

LOADING RATES FOR ANAEROBIC LAGOONS <sup>(1)</sup>	
Waste Source	Volume of Lagoon, cu ft/animal
Cows	2100
Horses	1800
Sheep	300
Hogs	240
Chickens	6
Column 1	2

**Note to Table XXX:**

<sup>(1)</sup> The figures in Table XXX have been arrived at by observing lagoons that appear to operate in a satisfactory manner.

(d) Combined anaerobic-aerobic lagoons

*“Combined anaerobic-aerobic lagoon” means a lagoon system with 2 or more cells operated in series where fresh manure is deposited in the first cell for anaerobic processing and the effluent flows into the subsequent cell(s) for aerobic processing.*

**2.2.6.4.(1)(d)**

(i) These lagoons should be used only where their odours will not create a nuisance. (See Subclause 2.2.6.4.(1)(c)(i).)

(ii) Where anaerobic lagoons are not permitted (see Subclause 2.2.6.4.(1)(c)(ii)), combined anaerobic-aerobic lagoons may produce a final effluent acceptable for discharge into a receiving body of water.

(iii) Where combined anaerobic-aerobic lagoons are used, approval of designs should be secured from proper local authorities before construction is begun. Tables XXXI(a) and (b) may be used to determine the capacities of the anaerobic and the aerobic cells required.

**Table XXXI(a)**

<b>LOADING RATES FOR ANAEROBIC CELL OF COMBINED ANAEROBIC-AEROBIC LAGOONS DESIGNED FOR A MANURE RETENTION PERIOD OF 1 YEAR</b>	
<b>Waste Source</b>	<b>Volume of Anaerobic Cell to Provide Manure Retention for 1 Year, cu ft/animal</b>
Dairy cows	585
Beef cows	365
Horses	335
Sheep	36
Hogs (no bedding)	65
Sows and litter	260
Layers	1.5
Column 1	2

**Table XXXI(b)**

<b>LOADING RATES FOR AEROBIC CELL OF COMBINED ANAEROBIC-AEROBIC LAGOONS<sup>(1)</sup></b>			
<b>Waste Source</b>	<b>Animals Per Acre of Aerobic Cell</b>		
<b>Man</b>	<b>Domestic Sewage Loading Rates, population/acre</b>		
	<b>100</b>	<b>150</b>	<b>200</b>
Cows	43	65	86
Horses	50	75	100
Sheep	275	413	550
Hogs	360	540	720
Chickens	15,000	22,000	30,000
Column 1	2	3	4

**Note to Table XXXI(b):**

<sup>(1)</sup> Proper local authorities should be consulted before allowing effluent to discharge to receiving waters. Further processing can be provided by additional aerobic cells or by spreading on cropland.

**(2) Shape**

- (a) Lagoons should be regular in shape with rounded corners and flat bottoms.
- (b) Embankments should have a minimum top width of 8 ft and a side slope of 1 vertical to 3 horizontal.

**2.2.6.4.**

**(3) Depth**

- (a) The operating depth of the liquid in aerobic lagoons or aerobic cells of combined anaerobic-aerobic lagoons should be capable of being varied from 2.5 ft to 5 ft to allow the liquid level to be raised to 5 ft during winter months. The operating depth during ice-free periods should not be greater than 3.5 ft.
- (b) The operating depth of liquid in anaerobic lagoons or anaerobic cells of combined anaerobic-aerobic lagoons should be at least 6 ft.
- (c) The top of the embankment should be at an elevation at least 2 ft above the maximum operating liquid elevation.

**(4) Inlets**

- (a) The waste inlet should slope at least 1 vertical to 50 horizontal, be at least 6 in. in diameter and discharge at an elevation of at least 2 ft above the maximum operating liquid level in the lagoon.
- (b) In areas where snow and ice would block an elevated inlet, wastes should be pumped through the inlet and discharged below ice level near the centre of the lagoon.

**(5) Outlets**

- (a) The outlet structure should be placed so that ice will not damage the structure. The outlet should be constructed so that the liquid depth can be changed and the lagoon drained when necessary.

**(6) Miscellaneous**

- (a) Lagoons should be filled with water to a depth of 2 ft before they are put into operation.
- (b) Lagoons should be provided with safety features conforming to Sentence 1.3.2.5.(3).

**2.2.6.5. Cropland Requirements for Manure Disposal**

(1) The total acreage required for the disposal of animal manures by spreading on cropland is determined by the volume of manure produced and the utilization of nitrogen, phosphorus and potash by the crop. The nitrogen factor is most important, as excessive build-up of nitrates must be avoided.

(2) The kind of manure management system used has a very large influence on the actual nutrient content of manure when applied to land. Soil tests and manure analyses should be made and agricultural agencies consulted to plan manure utilization programs according to local practices. Table XXXII provides information only on nutrients in freshly voided manure.

**Table XXXII**

<b>NITROGEN, PHOSPHORUS AND POTASSIUM EXCRETED BY ANIMALS OVER A 365-DAY PERIOD<sup>(1)</sup></b>			
<b>Class of Animal</b>	<b>Nitrogen, lb</b>	<b>Phosphorus, lb</b>	<b>Potash, lb</b>
1 dairy cow (1200 lb)	140	65	175
2 beef cows (400-1100 lb)	140	65	175
6 hogs (30-200 lb)	140	79	49
120 hens (5 lb)	140	112	62
180 broilers (0-4 lb)	140	63	54
<b>Column 1</b>	<b>2</b>	<b>3</b>	<b>4</b>

**Note to Table XXXII:**

<sup>(1)</sup> Jones, G.E., Lane, T.H. and Webber, L.R., 1968 (see Bibliography).

### 2.2.6.5.

(3) Nitrate should not be allowed to enter groundwater or surface water because of its potential toxicity when consumed by animals and infants.

(4) Soil testing services should be used to determine plant nutrient requirements. Nitrogen applications should be based on soil test results.

#### 2.2.6.6.(1) Oxidation Ditches

(a) Oxidation ditches for the continuous processing of swine waste should be designed using the following guidelines:

(i) Liquid volume in the ditch should be 10 cu ft per hog (150 lb average weight).

(ii) Liquid depth in the ditch should be between 18 in. (preferred) and 24 in. max.

(iii) The total depth of the ditch should be sufficient to provide 1 ft clearance between the liquid surface and the lowest member of the slotted floor structure.

(iv) The maximum spacing between aerators should be 350 ft along the ditch length.

(v) Aerator capacity should be sufficient to add 0.6 to 0.8 lb of oxygen per hog daily (150 lb average hog weight).

(vi) Aerators should have a pumping capacity to circulate liquid around the ditch at a velocity of 1.25 ft/sec.

(vii) A foam switch may be installed to act as a safeguard against unexpected foaming.

(viii) Manufacturers should be consulted to determine rated capacities of aerators.

#### 2.2.6.7. Mechanically Aerated Lagoons

(1) Mechanically aerated lagoons should be used only in locations where rigid odour or pollution controls prohibit the use of other methods of waste disposal. Approval of the design should be obtained from the local authorities.

(2) Mechanically aerated lagoons should be designed as follows:

(a) Size

(i) Where the lagoon is to be desludged annually or more often, the volume should be 50 times the daily manure input.

(ii) Where the lagoon is to be designed for long term storage, the volume required should be based on providing a minimum manure detention time of 2 years. Table XXXIII may be used to determine the size of lagoon.

Table XXXIII

VOLUME REQUIRED FOR MECHANICALLY AERATED LAGOONS RECEIVING RAW ANIMAL WASTES <sup>(1)</sup> (800 Days Detention Time)	
Class of Animal	Volume for each Pound of Animal, cu ft
Poultry	0.75
Swine	1.00
Dairy cattle	1.25
Beef cattle	0.75
Column 1	2

Note to Table XXXIII:

<sup>(1)</sup> Jones, D.D., Day, D.L. and Dale, A.C., 1970 (see Bibliography).

### 2.2.6.7.(2)

#### (b) Aeration Equipment

(i) The aerator should have a minimum oxygenation capacity of 1.5 times the total daily BOD<sub>5</sub> loading in order to obtain stabilization if weather conditions permit continuous winter operations. (See Table XXXIV.)

(ii) The aerator should have a minimum oxygenation capacity of 3 times the total daily BOD<sub>5</sub> loading if the equipment is to be shut off when mean daily temperatures are below 32°F. (See Table XXXIV.)

**Table XXXIV**

<b>BOD<sub>5</sub> VALUES FOR MANURE PER 1000 POUNDS OF ANIMAL LIVE WEIGHT<sup>(1),(3)</sup></b>	
<b>Class of Animal</b>	<b>BOD<sub>5</sub>, lb per day</b>
Beef cattle	1.5 <sup>(2)</sup>
Chicken	4.4
Dairy cattle	1.7
Sheep	0.7
Swine	2.1
Column I	2

#### **Notes to Table XXXIV:**

<sup>(1)</sup> Jones, D.D., Day, D.L. and Dale, A.C., 1970 (see Bibliography).

<sup>(2)</sup> The value for beef was estimated by the authors.

<sup>(3)</sup> Only limited data are available. Where possible samples of specific waste should be analyzed before processing facilities are designed and constructed.

#### (c) Removal of sludge and liquid supernatant.

(i) Provision should be made for the removal of sludge and supernatant.

(ii) Sludge and liquid supernatant removed from aerated lagoons should not be discharged into a stream or watercourse.

(iii) Sludge and liquid supernatant should be spread on cropland.

### 2.2.6.8. Feedlot Runoff Control Facilities

Surface runoff from manure-covered areas is capable of polluting water supplies. To minimize this hazard the following procedures should be followed:

- (1) Unpolluted drainage from adjoining areas should be diverted from feedlots by ditches or terraces, and roof drainage from adjoining buildings should be diverted by either sloping roofs away from feedlots or by installing eaves troughing.
- (2) Where feedlot runoff control is required, runoff should be collected in either a single basin system, or a double basin system consisting of a settling basin to remove solids and a detention basin to hold the settling basin overflow.
- (3) Hydrologic factors that govern feedlot runoff should be taken into account to determine required basin capacities. Local pollution control requirements for capacity should be met.
- (4) Provision should be made for periodic removal of wastes from the basins and their application on cropland.
- (5) Approval of design should be secured from local authorities.



## SECTION 2.3 CONSTRUCTION PRACTICES

### SUBSECTION 2.3.1. GENERAL

**2.3.1.1.(1)** All materials, systems and equipment should possess the essential properties to perform their intended functions in the structures.

(2) All members should be so framed, anchored, fastened, tied and braced together to provide the strength and rigidity necessary for the purpose intended.

### SUBSECTION 2.3.2. CLADDING

This Subsection deals with the design, properties and application of cladding for farm buildings.

#### 2.3.2.1. Metal Cladding

##### (1) General

- (a) Cladding should be applied to effect a weather-tight seal and to present a neat and workmanlike appearance.
- (b) Sheets should be stored in a dry place or in such a manner as to allow air circulation between the sheets to avoid condensation. Wet sheets should be separated immediately and allowed to dry to prevent staining.
- (c) Holes for fixing should be 1 in. or more from the ends of the sheets.
- (d) All exposed edges of the side laps should finish down, and this edge should turn away from the prevailing winds. Fasteners for siding should be located in the valley of the profile and adjacent to the rib. Roof fasteners may also be in roofing valleys provided the fastener makes a permanent watertight connection.
- (e) Manufacturers loading tables for exterior metal claddings should be used to determine purlin or girt spacing in relation to sheet profile.
- (f) Purlin spacing at eaves and ridge should be 50 per cent of recommended spacing for intermediate purlins.
- (g) Copper or bare steel accessories should not be used either in contact with aluminum or where water could drip down from them onto the aluminum.
- (h) When aluminum sheets are to be applied over hardwood, a 15-lb asphalt-impregnated felt should first be placed over such wood. An alternative is to apply 2 coats of bituminous paint.
- (i) Where aluminum sheets are to be applied in contact with concrete, 2 coats of bituminous paint should be applied or a 15-lb asphalt-impregnated felt placed over the concrete.
- (j) Fasteners should be of aluminum or galvanized steel.
- (k) Translucent skylight material should be of a reinforced polyester type and have a profile to match the adjacent siding or roofing metal.

##### (2) Roofing

- (a) The roof slope should be a minimum of 4 in 12, except when special low slope roof profiles are recommended by the manufacturer.
- (b) Sidelaps should be according to the manufacturer's recommendations, but should be nailed at each purlin and consist of 1 rib or more with both sides of the rib supported by purlins.
- (c) Endlaps should be according to the manufacturer's recommendations, but should be 6 in. or more and supported by a purlin.

### 2.3.2.1.(2)

- (d) Fasteners should be corrosion resistant and have a spiral or ring shank when applied in wood purlins. For metal purlins use self tapping screws or bolts and nuts. Fasteners should be provided with washers which seal the hole when the fastener is tightened. Fasteners should be through the crown of the rib at each purlin and spaced across the sheet according to the manufacturer's recommendations. In maritime areas aluminum nails with neoprene washers should be used.
- (e) **Reroofing**  
Metal roofing can be applied over old roofing provided the roof deck is solid and the old roofing is clean, dry and flat and loose pieces are fastened down. It is good practice to restrap over old roofing with 1-in. by 4-in. strapping fastened in a secure manner. Metal roofing should not be applied directly over old metal, slate or tile. Where new aluminum roofing laps other metals, a coat of bituminous paint should be applied between the sheets before lapping.
- (3) **Siding**
  - (a) Sidelaps should be according to the manufacturer's recommendations, but should be nailed at each purlin and consist of 1 rib or more.
  - (b) Endlaps should be according to the manufacturer's recommendations but should be 4 in. or more and supported by a girt.
  - (c) Fasteners should be corrosion resistant and have a spiral or ring shank.
- (4) **Finishes for steel**
  - (a) Zinc coating for protection of exterior steel cladding should conform to ASTM A446-72, "Steel Sheet Zinc Coated (Galvanized) by the Hot-Dip Process" Grade A, and
  - (b) Steel in contact with high-moisture feeds treated with acid preservatives such as propionic acid should be coated with chlorinated rubber paint over a primer in accordance with the manufacturer's recommendations.

### 2.3.2.2. Asbestos Cement, Corrugated

- (1) **General**
  - (a) Corrugated asbestos cement cladding should be applied to afford a weathertight seal and to present a neat and workmanlike appearance.
  - (b) Sheets should be stored in a dry place.
  - (c) No hole for fixing shall be nearer than 1 in. to the end of a sheet.
  - (d) All sidelaps should be installed away from prevailing winds.
  - (e) Purlin and girt spacings depend upon local climatic conditions. These should be in accordance with the manufacturer's recommendations.
- (2) **Roofing**
  - (a) The recommended minimum roof slope for corrugated asbestos-cement roofing should be 3 in 12.
  - (b) Sidelaps should be 1 corrugation with caulking between corrugations.
  - (c) Endlaps should be a minimum of 6 in., supported by a purlin, with caulking between sheets.
  - (d) Corrosion-resistant fasteners should have a spiral or screw shank and be provided with washers which will seal the hole when the fastener is tightened. Fasteners should pierce the crown of the corrugation at each purlin and should be spaced across the sheet according to the manufacturer's recommendations.

### 2.3.2.2.(2)

- (e) Corrugated asbestos-cement roofing can be applied over old wood roofing provided the deck is solid, the old material is clean, dry and flat and loose pieces are fastened down. It is good practice to restrap over old roofing with 1-in. by 4-in. strapping fastened in a secure manner. Asbestos-cement roofing should not be applied over old metal, slate or tile roofing.

### (3) Siding

- (a) Sidelaps of corrugated asbestos-cement siding should be 1 corrugation with caulking between corrugations.
- (b) Endlaps should be a minimum of 6 in. and supported by a girt.
- (c) Corrosion-resistant fasteners should have a spiral or screw shank and be provided with weather sealing washers.

### 2.3.2.3. Asphalt Shingles

Asphalt shingles should conform to the requirements in Subsections 9.27.7. and 9.27.8. of the National Building Code of Canada 1975.

### 2.3.2.4. Lumber Siding

(1) Lumber siding should be free of knot holes or loose knots larger than  $\frac{1}{2}$  in. diam. and should have no checks or splits longer than  $\frac{1}{2}$  of the width of the piece.

(2) Bevel siding should be not less than  $\frac{3}{16}$  in. thick at the tip and  $\frac{7}{16}$  in. at the butt. Bevel siding should be not more than 12 in. wide. Other siding, including vertical wood siding, should be not less than  $\frac{9}{16}$  in. thick and not more than 12 in. wide.

(3) Furring should be at least 1-in. by 2-in. lumber if the furring is applied horizontally over sheathing. When furring is applied without sheathing to studs not more than 48 in. o.c., it should be not less than 2-in. by 2-in. or 1-in. by 4-in. wood.

(4) Lumber siding should prevent water from entering at the joints by the use of lapped or matched joints or by vertical wood battens. Siding should overlap at least  $\frac{1}{16}$  in. per inch width of lumber, but not less than  $\frac{3}{8}$  in. for matched siding, 1 in. for lapped bevel siding or  $\frac{1}{2}$  in. for vertical battens. Joints should be butted over studs, furring, blocking or lumber sheathing.

(5) Lumber siding should be fastened with corrosion-resistant nails spaced not more than 24 in. o.c. to framing, furring or lumber sheathing or to blocking nailed between framing members and spaced not more than 24 in. o.c.

- (6) Blocking should be not less than 2-in. by 2-in. lumber.

### 2.3.2.5. Wood Shingles

(1) Shingles should be No. 2 grade or better.

(2) Decking for wood shingled roofs may be continuous or spaced.

(3) Wood shingles should be at least 16 in. long and not less than 3 in. or more than 14 in. wide.

(4) Shingles should be spaced approximately  $\frac{1}{4}$  in. apart and offset at the joints in adjacent courses at least  $\frac{1}{2}$  in. in such a manner that joints in alternate courses do not line up.

(5) Shingles should be fastened with 2 corrosion-resistant, 14-gauge shingle nails or the equivalent, located approximately  $\frac{3}{4}$  in. from the sides of the shingles and  $\frac{1}{2}$  in. above the exposure line.

(6) The maximum exposure of wood roof shingles should conform to Table XXXV.

2.3.2.5.(6)

Table XXXV

MAXIMUM EXPOSURE OF WOOD ROOF SHINGLES			
Roof Slope	Maximum Shingle Exposure, in.		
	16-in. Shingles	18-in. Shingles	24-in. Shingles
4/12 or less	3¾	4¼	5¾
Over 4/12	5	5½	7½
Column 1	2	3	4

2.3.2.6. Flakeboard, Type I (Exterior)

(1) General

Flakeboard used in farm structures should be phenolic bonded conforming to CSA O188-1968, "Mat-Formed Wood Particleboard," Building Board, Type I, Grade P.

It should be marked with a stamp or brand on the panel edge that includes the symbol P 100.

(2) Standard grades of exterior flakeboard are unsanded, and sanded one side; sizes are 4 ft by 8 ft and 4 ft by 16 ft and thicknesses are ¼ in., ⅜ in., ½ in., ⅝ in. and ¾ in.

(3) Walls

Recommended applications of exterior flakeboard wall sheathing, cladding and interior finish for farm structures are given in Table M-III, Appendix M.

(4) Finishes

For exterior application unsanded exterior flakeboard is recommended. A light- or medium-bodied stain should be used, or a heavy bodied shingle stain for a solid colour finish.

(5) Roofs

Recommended applications of exterior flakeboard for flat, flat-pitched or pitched roofs on farm buildings are covered by Table M-IV, Appendix M. These recommendations are suitable for areas in which the National Building Code specifies a ground snow load of 60 psf or less.

2.3.2.7. Plywood

(1) General

(a) Plywood used in farm structures should be exterior type conforming to one of the following standards:

CSA O121-1973, "Douglas Fir Plywood,"

CSA O151-1974, "Canadian Softwood Plywood," or

CSA O153-1963, "Poplar Plywood."

It should be marked to designate the manufacturer, the bond type (exterior), the species and grade.

(2) Walls

(a) Recommended applications of Fir plywood wall sheathing, cladding and interior finish for farm structures are given in Table M-I, Appendix M.

(3) Finishes

(a) A stain finish is recommended for Sheathing or Select Sheathing grade plywood panels exposed to the weather. A heavy body stain of the type sold as shingle or shake stain is recommended and will provide an attractive finish requiring little maintenance.

### 2.3.2.7.(3)

(b) For a high quality paint finish the use of Medium Density Overlaid Fir plywood is recommended. Painting recommendations for Medium Density Overlaid plywood are as follows:

(i) Surface preparation

Medium Density Overlaid plywood needs no surface preparation. No presanding or sealer coats are required. However, it is important that the surface has been dry for at least 48 hr and is completely clean before application of paint.

(ii) Prime coat

Any good primer properly formulated and designed for exterior exposure may be used with satisfactory results. The limitations are as follows:

1. Strict adherence to the paint manufacturer's recommendations.
2. Compatibility of the prime coat to the top coat must be considered. The use of flexible film forming primers, such as some of the latex or oleoresinous based formulations, should be avoided when they are to be top coated with a hard film forming paint.

(iii) Top or finish coat

Nearly all good quality paints formulated for exterior finish are acceptable. As with the prime coat, the manufacturer's recommendations must be followed, and the compatibility of the top coat to the primer should be considered.

### (4) Roofs

Recommended applications of Fir plywood roof sheathing for flat, flatpitched or pitched roofs on farm buildings are covered by Table M-II, Appendix M. These recommendations are suitable for areas in which the National Building Code of Canada 1975 specifies a ground snow load of 60 psf or less. To support point loads imposed during construction, these thicknesses should not be reduced nor should these spans be increased. Plywood roof sheathing should be applied with face grain at right angles to rafters or other primary supports.

For ground snow loads higher or substantially lower than 60 psf reference should be made to load span figures, Figures 1-M to 5-M, Appendix M.

### (5) Load/span graphs

For plywood applications subject to continuous uniformly distributed loading, load/span figures, Figures 1-M to 5-M in Appendix M may be used as a guide to determine suitable thicknesses of plywood and spacing of supports.

## SUBSECTION 2.3.3. VAPOUR BARRIERS

### 2.3.3.1. Materials

Materials should conform to requirements for Type I vapour barrier in accordance with CGSB 70-GP-1a (1970), "Vapour Barrier: Sheet, for Use in Above-Grade Building Construction," or otherwise permanent resistance should be provided to the passage of water vapour of 0.25 perms or less when applied.

### 2.3.3.2. Installation

(1) Vapour barriers should be installed on the warm side of all insulated assemblies as near to the surface as possible if insulation is used that is a type which, when installed, does not effectively limit the passage of water vapour over the entire surface.

(2) All joints should be located over supporting members and lap at least 1 in.

(3) The entire surface, including framing members, should be protected with the vapour barrier so that no gaps occur.

### 2.3.3.2.

(4) Openings should be cut in such a manner that the vapour barrier fits snugly around electrical outlets, water pipes, etc. without damaging the insulation.

Plumbing and electrical services should, wherever possible, be surface mounted to the interior to avoid penetrating the vapour barrier.

(5) Damaged vapour barriers should be repaired or replaced.

## SUBSECTION 2.3.4. INSULATION

### 2.3.4.1. General

(1) Insulation should be installed in agricultural buildings where required to prevent condensation and to establish a heat balance between that produced by the animals or materials contained in the structure and the heat lost through the walls, floors and ceilings and ventilation (see Tables on heat production in Appendices I and J).

(2) Insulation should be provided between heated and unheated spaces and around the perimeter of concrete slabs on grade.

### 2.3.4.2. Insulation Values

For insulation values (R) of selected materials frequently used in farm building construction, see Tables N-I and N-II, Appendix N. For a more complete listing of insulation values refer to the ASHRAE Handbook of Fundamentals published by the American Society of Heating, Refrigerating and Air Conditioning Engineers, Inc.

### 2.3.4.3. Materials

(1) Insulating materials should conform to the following:

- (a) U.S. Federal Specification HH-I 525A, 4 October 1968, "Insulation Board, Thermal, Cork."
- (b) U.S. Federal Specification HH-C-571C, 17 October 1969, "Cork Granulated,"
- (c) CSA A247.1-1969, "Fibreboard Roof Insulation,"
- (d) CSA A247.2-1969, "Insulating Fibreboard Sheathing,"
- (e) CSA A247.3-1969, "Fibreboard Used in Interior Application,"
- (f) CSA A101-1968, "Mineral Wool Thermal Building Insulation,"
- (g) CGSB 41-GP-14a 1972, "Thermal Insulation, Expanded Polystyrene," or
- (h) ASTM C516-67, "Vermiculite Loose Fill Insulation."

(2) Materials used for insulation that is in contact with the ground should be inert to the action of soil and water. Materials whose insulating property is significantly reduced by moisture should not be used in any potentially wet locations.

(3) Materials such as straw should be used for short term insulation only.

(4) Damaged insulation should be repaired or replaced.

(5) Polystyrene based foam insulations are readily soluble in many organic solvents including petroleum oils and fuels; polystyrene foam should therefore be used only where there is no contact with such chemicals.

### 2.3.4.4. Methods of Installation

(1) Insulation should be installed in such a manner that there is a reasonably uniform insulating value over the entire face of the insulated area.

#### 2.3.4.4.

- (2) Insulation should occupy the full width and length or height of the space between furring or framing members when applied therein.
- (3) In new buildings loose fill insulation should be used only on horizontal surfaces, except that purpose-designed granular types are acceptable for cavity wall construction in the cavity between the outer and inner wythes.
- (4) Insulation of foundation walls enclosing heated buildings and in buildings where heat loss is critical should extend at least 12 in. below adjacent grade.
- (5) Insulation around concrete slabs on grade should extend at least 12 in. below exterior grade and be located so that heat is not restricted from reaching the ground beneath the perimeter if exterior walls are not supported by footings extending below frost level.
- (6) Where insulation would be exposed to the weather and subject to mechanical damage, it should be protected.

#### 2.3.4.5. Insulation and Surface Protection for Unit Masonry

- (1) When granular insulation is used in conjunction with masonry units, the warm side of the walls should be sealed with a vapour sealing material. The outside of the walls should also be protected to keep out wind-driven rains.
- (2) When rigid insulation is used and is exposed to mechanical damage, it should be covered with a protective plaster coat or other suitable material.

### SUBSECTION 2.3.5. WOOD PRESERVATION

2.3.5.1.(1) Wood in contact with earth, manure packs or deep poultry litter should be pressure treated with an effective preservative in accordance with CSA O80-1974, "Wood Preservation." Cedar poles for pole barns may be used without treatment, but the life expectancy will be appreciably less than that of pressure treated poles. With other species thermal (hot and cold bath) treatment with an oil type preservative will provide greatly increased life. Soaking of well-seasoned material for at least 48 hr in an oil type preservative will provide increased life, but somewhat less than that provided by thermal treatment.

- (2) Fruit, vegetables or grain should not be placed in contact with toxic preserved wood.
- (3) Wood that will be in contact with concrete or masonry under conditions which favor decay should be pressure treated in accordance with the requirements of CSA O80-1974, "Wood Preservation."
- (4) All boring, grooving and other possible fabrication should be completed before treatment.
- (5) All fabrication carried out after treatment should be locally treated in accordance with CSA O80-1974, "Wood Preservation."

### SUBSECTION 2.3.6. DRAINAGE

#### 2.3.6.1. General

- (1) In wet areas exterior foundation walls should be drained by laying drain tile, perforated drain pipe or tubing around the exterior of the foundation so that the top of the drain is below the bottom of the floor slab.
- (2) Drains should be laid on a uniform grade to carry the water away from foundations to an outlet that always remains open.
- (3) Drain tile with butt ends should be laid with  $\frac{1}{4}$  in. to  $\frac{3}{8}$  in. open joints, and cover strips of durable material at least 3 in. wide should be placed over at least the top half of the open joints.

#### **2.3.6.1.**

(4) When perforated drain pipe is used, the pipe should be laid with perforations down. Such pipe may be connected with couplings.

(5) At least 6 in. of granular material should be placed over the drain.

#### **2.3.6.2. Slabs-Below-Grade**

(1) Where groundwater levels may cause uplift pressures against the bottom of a slab-below-grade, lateral drains should be installed under the slab.

#### **2.3.6.3. Slabs-on-Grade**

(1) The accumulation of water underneath a slab-on-grade should be prevented by grading, drainage or other method.

#### **2.3.6.4. Floor Slopes**

(1) For drainage, animal floors should slope at least  $\frac{1}{8}$  in./ft except as follows:

(a) hog floors, dunging area, at least  $\frac{1}{2}$  in./ft,

(b) hog floors bedded area,  $\frac{1}{4}$  in./ft,

(c) yard slabs,  $\frac{1}{4}$  in./ft,

(d) dairy barn stalls and litter alleys,  $\frac{1}{4}$  in./ft,

(e) milking parlours, cow platform area,  $\frac{1}{2}$  in./ft, and

(f) gutters for mechanical gutter cleaners, zero slope except at the point where the gutter passes through the exterior wall, slope inwards 1 in./4 ft to prevent freezing.



## LIST OF AGENCIES ISSUING STANDARDS AND GRADING RULES

Standards referred to in this document can be obtained directly from:

American Concrete Institute  
Box 4754 Redford Station  
22400 West Seven Mile Road  
Detroit, Michigan 48219 U.S.A.

American Society for Testing and Materials  
1916 Race Street  
Philadelphia, Pennsylvania 19103 U.S.A.

British Standards Institution  
101-112 Pentonville Road  
London N. 1, Great Britain.

Canadian Government Specifications Board  
88 Metcalfe Street  
c/o Department of Supply and Services  
Ottawa, Ontario K1A 0S5

Canadian Standards Association  
178 Rexdale Boulevard  
Rexdale, Ontario M9W 1R3

National Fire Protection Association  
470 Atlantic Avenue  
Boston, Massachusetts 02210  
U.S.A.

United States General Services Administration  
c/o Superintendent of Documents  
U.S. Government Printing Office  
Washington, D.C. 20402 U.S.A.

Grading rules referred to in this document can be obtained directly from:

National Lumber Grades Authority  
1055 West Hastings St.  
Vancouver, B.C. V6E 2E9

## BIBLIOGRAPHY

- An Act Respecting Food and Drugs, Revised Statutes of Newfoundland 1952, Chapter 56. Province of Newfoundland, Dept. of Public Health.
- Agricultural Engineering Year Book 1963, 1969 & 1973. Amer. Soc. Agr. Engrs.
- Agriculture Engineers Digest 1963. Midwest Plan Service, Ames, Iowa.
- American Society of Agricultural Engineers. Journal, September 1959, September 1960 and December 1962.
- American Society of Agricultural Engineers, Transactions, 1959.
- ASHRAE Guide and Data Book, 1967, Applications. American Society of Heating, Refrigerating and Air-Conditioning Engineers.
- Armstrong, D.G., et al. The effect of environmental conditions of food utilization by sheep. Animal Production (British Society of Animal Production), Vol. 1, Part 1, March 1959.
- Barre, H.J. and Sammet, L.L. Farm structures. John Wiley and Sons, 1955.
- Berglund, S., Ariansson, G. and Ekesbo, I. Liquid manure handling. Swedish Institute of Agricultural Engineering. Bulletin 310. Ultuna, Uppsala, 1965.
- Binwall Design and Construction. Committee 313, American Concrete Institute, July 1968.
- Blaxter, K.L., Graham, M.N. and Wainman, F.W. The effect of environmental conditions of food utilization by sheep. Animal Production, (British Society of Animal Production), Pt. 1, March 1959.
- Blaxter, K. and Wainman, F.W. Environmental temperature and the energy metabolism and heat emission of steers. Journal of Agricultural Science. Vol. 56, 1961.
- Bond, T.E., Kelly, C.F. and Heitman, H. Jr. Heat and moisture loss from swine. Agricultural Engineering, March 1952.
- Bond, T.E., Kelly, C.F. and Heitman, H. Jr. Hog house air conditioning and ventilation data. Trans., Amer. Soc. Agr. Engrs, Vol. 2, No. 1, 1959, pp. 1-4.
- Boyd, J.S. Proceedings of Michigan Silo Conference 1961. Michigan State University.
- Buffington, D.E., Jordon, K.A. and Boyd, L.L. Determination and Modeling Heat Production of Active, Growing Turkeys. ASCE Paper No. 72-905, 1972.
- Commercial Storage of Fruits, Vegetables, and Florists and Nursery Stock. Agricultural Handbook 66, U.S. Department of Agriculture, September 1954.
- Eby, H.J. Manure Disposal Lagoons. Agric. Eng. Res. Div, ARS, pp. 42-75, U.S.D.A., College Park, Maryland, 1963.
- Effects of Floor Type on Required Moisture-Vapor Removal Rate From Swine Finishing Houses. Amer. Soc. Agr. Engrs., Vol. 11, No. 1, 1968.
- Ewing, W.R. Handbook of poultry nutrition, South Pasadena, California, 1953.
- Grain Storage Load, Farm Construction Standards Committee paper, Amer. Soc. Agr. Engrs.
- Grain Storage Loads, Pressures and Capacities. Amer. Soc. Agr. Engrs., D 240, 1969 Agricultural Engineers Yearbook.
- Gray, H.E. Farm Service Building. McGraw-Hill, 1955.
- Handbook on the Storage of Fruits and Vegetables for Farm and Commercial Use. Canada Department of Agriculture, Publication No. 1260, 1967.
- Harman, D.J., Dale, A.C. and Jones, H.W. Effect of floor type on required moisture-vapor removal rate from swine finishing houses. Trans., Amer. Soc. Agr. Engrs., Vol. 11, No. 1, 1968, pp. 149-152.
- Hog House Air Conditioning and Ventilation Data. Amer. Soc. Agr. Engrs., Vol. 2, No. 2, 1959.
- Jones, D.D., Day, D.L. and Dale, A.C. Aerobic Treatment of Livestock Wastes. University of Illinois, Bulletin 737, 1970.
- Jones, G.E., Lane, T.H. and Webber, L.R. Land requirements for utilization of liquid manure in crop production. Ontario, Dept. of Agriculture and Food, Toronto, Information Leaflet, 1968.
- Kibler, H.H. Energy metabolism and cardiorespiratory activities in Shorthorn, Santa Gertrudis, and Brahman heifers during growth at 50° and 80°F temperatures. Univ. of Missouri, Missouri Research Bulletin 643, 1957.
- Kibler, H.H. and Yeck, R.G. Vaporization rates and heat tolerance in growing Shorthorn, Brahman and Santa Gertrudis calves raised at constant 50° and 80°F temperatures. Univ. of Missouri, Missouri Research Bulletin 701, 1959.

- Kibler, H.H., Yeck, R.G. and Berry, I.L. Vaporization rates in Brown Swiss, Holstein, and Jersey calves during growth at constant 50° and 80°F temperatures. Univ. of Missouri, Missouri Research Bulletin 792, 1962.
- Manitoba Dairy Act, Chapter 58, Statutes of Manitoba 1954, and Manitoba Regulation 1558, Province of Manitoba, Department of Public Health and Welfare.
- The Milk Act, 1965, Statutes of Ontario, 1965, Chapter 72 as amended by The Milk Amendment Act, 1967, Toronto, 1967.
- Minimum Requirements for Construction of Equipment and Maintenance of Milk Plants and Receiving Stations. Province of Manitoba, Dept. of Health and Public Welfare, December 1960.
- Ota, H. and McNally, E.H. Poultry respiration calorimeter studies of laying hens. U.S.D.A., Agr. Research Service, pp. 42-43, June 1961.
- Ota, H. and McNally, E.H. Preliminary broiler heat and moisture data for designing poultry houses and ventilating systems. Amer. Soc. Agr. Engrs., Paper No. 65-411, June 1965.
- PMBC forms. Plywood Manufacturers Association of B.C., 1477 West Pender Street, Vancouver 5, B.C.
- Poultry Respiration Calorimeter Studies of Laying Hens. U.S.D.A. Agriculture Research Service, June 1961.
- Preliminary Broiler Heat and Moisture Data for Designing Poultry Houses and Ventilation Systems. Amer. Soc. Agr. Engrs., Paper No. 65-411, June 1965.
- The Public Health Act Standard Milk Regulations, 1960. Prince Edward Island, Dept. of Public Health.
- Regulations Governing the Construction, Maintenance and Operation of Class D Stock Yards, Livestock Diseases Act, Alberta Regulation 57/59. Province of Alberta, Dept. of Agriculture, 1959.
- Regulations Governing Milk and Certain Milk Products. Province of Saskatchewan, Dept. of Public Health, 1959.
- Regulations Governing the Production, Manufacture, Grading and Composition of Dairy Products Under the Dairyman's Act, Chapter 74, RSA 1955, Alberta Regulation 567-57. Province of Alberta, Dept. of Public Health.
- Regulations re Grading and Inspecting of Honey under the Vegetable and Honey Sales Act 1947. Province of Saskatchewan, Dept. of Public Health.
- Regulations Respecting Milk Production, Milk Transportation, Milk Pasteurization. Province of Nova Scotia, Dept. of Public Health, 1966.
- Regulations under the Milk Industry Act. BC Regulation 32-58 and 102-58, October 23, 1958. Province of British Columbia, Dept. of Public Health.
- Reitzman, E.G. and Benedict, F.G. The energy metabolism of sheep. New Hampshire Agricultural Experimental Station, Technical Bulletin No. 43, 1930.
- Reitzman, E.G. and Benedict, F.G. The heat production of sheep under varying conditions. New Hampshire Agricultural Experimental Station, Technical Bulletin No. 45, 1931.
- Sainsbury, D. Animal Health and Housing. Bailliere, Tindall and Cassell, London, 1967.
- Schaper, L.A. and Herrick, J.F. Jr. Lateral pressures on walls of potato storage bins. ARS 52-32, Agricultural Research Services, United States Department of Agriculture.
- Truscott, J.L. Short Term Storage of Horticultural Crops. Horticultural Products Laboratory, Vineland Station, Ont., July 1968.
- Turner, C.N. Electric water heaters for the dairy farm. Cornell University, Ithaca, N.Y., Extension Bulletin 1137, 1964.
- Wilson, G.B. Lateral Pressures on Walls of Storage Bins. USDA, Publication ARS 52-32, 1968.
- Yeck, R.G. and Stewart, R.E. A ten-year summary of the psychronegetic laboratory dairy cattle research at the University of Missouri. Trans. Amer. Soc. Agr. Engrs., Vol. 2, 1959.
- Yeck, R.G. and Stewart, R.E. Stable heat and moisture dissipation with dairy calves at temperatures of 50° and 80°F. Univ. of Missouri, Missouri Research Bulletin 759, November 1960.

## **APPENDIX A**

### **LOADS IMPOSED BY STORED GRAIN, POTATOES AND SILAGE**

# LOADS IMPOSED BY STORED GRAIN

## DEFINITIONS

### (1) Shallow Bin

Depth of grain (H) less than or equal to equivalent diameter (D).

$$\text{Or: } \frac{H}{B} < \tan \left( \frac{\phi}{2} + 45^\circ \right)$$

where B = width

$\phi$  = angle of repose (see Table A-II).

### (2) Deep Bin

Depth of grain (H) greater than the equivalent diameter (D).

Or: greater than second definition above.

### (3) Equivalent Diameter (D)

Round bins: D = bin diameter.

Rectangular bins:  $D = 4$  (floor area) / (perimeter).

Use building width instead of D if length is more than 1½ width.

### (4) Equivalent Fluid Density (EFD) (see Table A-II).

Grain is a semi-fluid. Both vertical and lateral loads are a function of depth. In the design of some bins discussed later, the EFD directly relates load and depth, assuming linearity.

## A. SHALLOW BINS

From Rankine's development

### (1) Lateral Load on Vertical Walls

$$l = \text{EFD} \times H$$

where l = lateral load, lb/sq ft

EFD = Equivalent Fluid Density (see Table A-II)

H = depth of grain, ft.

### (2) Total Lateral Load

$$L = \text{EFD} \times \frac{H^2}{2}$$

where L = the total lateral load on a vertical wall section, 1 ft wide

EFD = Equivalent Fluid Density (see Table A-II).

H = depth of grain, ft.

### (3) Vertical Loads on Vertical Walls

$$V = u' \times L$$

$u'$  = coefficient of friction for grain on wall (see Table A-I).

### (4) Vertical Loads on Horizontal Floors

$$V = \text{EFD} \times H$$

Conservative  $V$  = Bulk Density  $\times H$  (see Table F-II for bulk density).

**(5) Design Values – Equivalent Fluid Density (EFD)**

Effect of storage time: increase figures in Table A-II 25 per cent for storage longer than 1 year.

Effect of surcharge: increase figures in Table A-II 25 per cent for maximum surcharge.

(Note: These figures have checked out in extensive loading and pressure studies. They also agree with Rankine’s formula, using emptying angle of repose for angle of internal friction. See apparent inconsistency with data under Coulomb’s theory below.)

**(6) Inward Sloping or Inward Curving Walls**

EFD pressures will result in conservative designs.

Use Coulomb’s “wedge” theory.

(Note: With level fill and zero wall friction, Coulomb’s theory reduces to Rankine’s theory.)

**(7) Design Values – Coulomb’s Theory**

The angle of internal friction as determined from loading studies does not equal the unloading angle of repose as commonly used in the EFD method.

Angle of internal friction: shelled corn, 22 deg.; wheat, 31 deg.

**B. DEEP BINS**

**Janssen’s formula**

**(1) Lateral Load on Vertical Walls**

$$L = \frac{wD}{4u'} \left( 1 - e^{(-4Ku' H)/D} \right)$$

where: L = lateral pressure, psf

w = material density, pcf

D = bin diameter or equivalent diameter, ft

K = ratio of lateral to vertical internal pressure

=  $(1 - \sin \phi)/(1 + \sin \phi)$

$\phi$  = angle of repose (see Table A-II)

u' = coefficient of friction, material on wall (see Table A-I)

H = depth of grain, ft

e = Napierian log base

**(2) Vertical Load on Vertical Walls**

$$V = u' \times L$$

(Note: Vertical load and horizontal load may never be maximum at the same time.)

**(3) Vertical Load on Horizontal Floors**

$$F = L/K$$

**C. HOPPER BOTTOMS**

(1) Coulomb’s theory will work for shallow bins with sloping walls and/or floors.

(2) Deep bins – at any given depth, the forces on the hopper surface are

(a) Normal pressure =  $L \sin^2 \theta + L \cos^2 \theta / K$  where  $\theta$  is the angle between the hopper surface and the horizontal. (This formula is reported to be too conservative for deep bins.)

(b) Friction force parallel to surface = normal force times u'.

(c) Vertical tensile stress resulting from the lower end of a hopper face providing end reactions to another face.

- (d) Hoop stress in conical hoppers or horizontal tensile stress resulting from one face of the hopper providing end reactions to other faces.

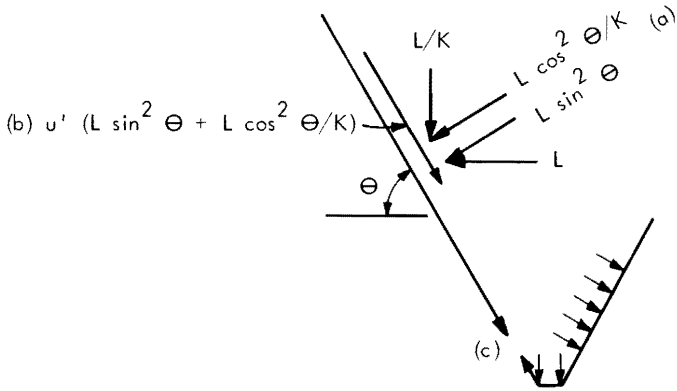

#### D. VERTICAL LOADS ON WALLS WITH EXPOSED HORIZONTAL GIRTS

Wall Load =  $F + V$

$F$  = vertical load on girts.

$V = u' \times L$  = vertical load on wall. In computing  $L$ , omit those areas "shaded" by the girts.

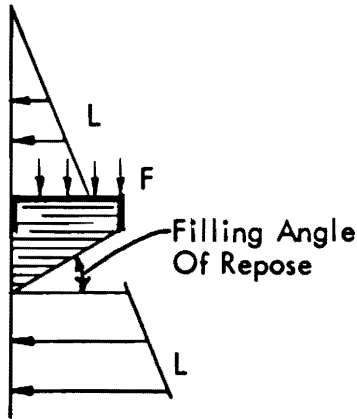

#### E. THERMAL EFFECTS

Coefficient of linear thermal expansion for 9.3 per cent corn = 0.0000187 in./in.

Temperature changes of ambient air will result in dimensional changes in the bin, and lower and/or smaller changes in the stored material. Differential changes between the bin and stored material result.

Sun warming of the bin surface, followed by settling of the stored material and subsequent cooling, may result in passive pressures. Because dimensional changes will be relatively small, elasticity of a grain mass (340 to 1000 psi) will permit yielding to reduce the apparent high stresses.

Yielding of the grain mass is reported to increase the EFD significantly as well as changing the stress patterns in the grain. Repeated cycles may lead to failure.

**F. MOISTURE EFFECTS**

In commercial warehousing and farm bins with the grain put in at safe moisture contents and with no drying anticipated, moisture changes are not important to structural design.

Wall pressures will increase at least 6 times if the moisture content of dry grain is raised 4 per cent. Pressures will increase 10 times with a 10 per cent moisture increase.

**G. UNLOADING EFFECTS**

A number of investigators report varying amounts of overloading during grain discharge.

No design values or procedures seem to be available at this time.

**H. PHYSICAL PROPERTIES OF STORED CROPS**

See Table A-I.



Table A-1

COEFFICIENTS OF FRICTION, $\mu'$ , FOR GRAINS AT VARIOUS MOISTURE CONTENTS ON VARIOUS SURFACES												
Material	Moisture Content, per cent	Surfaces										
		Concrete			Wood				Plastic		Metal	
		Plastic Smooth Finish	Steel Trowel Finish	Wood Float Finish	Oak		Douglas Fir		Polyethylene		Mild Steel, Cold Rolled	Galvanized Sheet Metal
			Grain Parallel	Grain Perpendicular	Grain Parallel	Grain Perpendicular	Grain Parallel	Grain Perpendicular				
Oats	10.6	.28	.40	.43	.20	.23	.27	.29	.20	.22	.20	.22
	13.0	.34	.44	.44	.24	.25	.29	.35	.24	.24	.26	.24
	14.0	.33	.51	.42	.23	.25	.34	.36	.28	.28	.21	.18
	16.0	.29	.46	.46	.31	.31	.37	.37	.31	.31	.20	.41
	17.3	.50	.65	.64	.46	.48	.48	.50	.50	.50	.44	.32
Wheat	11.2	.36	.52	.51	.24	.26	.31	.35	.27	.27	.20	.10
	13.0	.47	.52	.55	.25	.29	.35	.38	.35	.35	.29	.14
	15.0	.50	.55	.51	.35	.37	.47	.46	.39	.39	.27	.27
	15.7	.56	.68	.69	.41	.46	.48	.50	.45	.45	.51	.33
	7.1	.25	.39	.39	.24	.34	.29	.31	.25	.25	.19	.21
Soybeans	8.1	.32	.55	.52	.29	.38	.32	.37	.32	.32	.19	.21
	9.8	.31	.47	.37	.28	.31	.33	.31	.29	.29	.20	.18
	12.2	.36	.55	.52	.28	.36	.35	.44	.43	.43	.23	.20
	10.7	.23	.56	.50	.23	.29	.27	.32	.23	.23	.20	.20
	12.3	.25	.55	.52	.21	.28	.28	.31	.28	.28	.25	.17
Barley	14.3	.24	.57	.51	.21	.28	.30	.32	.28	.28	.29	.20
	16.4	.33	.62	.55	.30	.33	.34	.41	.35	.35	.21	.34
	2	3	4	5	6	7	8	9	10	11	12	

Table A-1 (Cont'd)

Material	Moisture Content, per cent	Surfaces										
		Concrete			Wood				Plastic		Metal	
		Plastic Smooth Finish	Steel Trowel Finish	Wood Float Finish	Oak		Douglas Fir		Polyethylene	Mild Steel, Cold Rolled	Galvanized Sheet Metal	
					Grain Parallel	Grain Perpendicular	Grain Parallel	Grain Perpendicular				
Shelled corn	7.5	.27	.41	.46	.24	.25	.27	.29	.22	.23	.20	
	9.9	.25	.59	.62	.28	.31	.31	.31	.27	.20	.24	
	12.2	.33	.68	.65	.26	.29	.33	.33	.30	.20	.25	
	13.9	.35	.64	.54	.29	.36	.37	.38	.38	.24	.37	
Alfalfa	82.0	.74	.69	.78	.61	.67	.70	.61	.61	.65	.54	
	33.3	.48	.56	.71	.37	.48	.39	.49	.39	.51	.37	
	22.2	.33	.65	.66	.31	.33	.33	.37	.32	.46	.36	
	77.0	.63	.68	.78	.58	.60	.60	.70	.65	.65	.64	
Alfalfa 75 per cent Timothy 25 per cent	26.2	.28	.49	.73	.31	.39	.36	.42	.33	.36	.38	
	21.3	.26	.49	.62	.31	.36	.32	.39	.19	.35	.27	
Alfalfa 25 per cent Timothy 75 per cent	81.1	.62	.69	.83	.52	.64	.66	.65	.62	.57	.59	
	49.3	.51	.60	.82	.44	.56	.45	.59	.61	.43	.50	
	21.6	.25	.53	.66	.31	.38	.37	.43	.23	.32	.29	
	79.3	.58	.60	.77	.52	.53	.64	.60	.66	.57	.53	
Timothy	38.1	.46	.59	.78	.51	.56	.53	.64	.52	.43	.32	
	30.5	.37	.48	.73	.44	.38	.42	.52	.38	.39	.48	
	16.7	.27	.45	.63	.35	.42	.40	.44	.21	.32	.32	
	14.95	.20	.36	.45	.20	.26	.22	.25	.22	.35	.30	
Bedding Shavings	9.5	.35	.70	.73	.46	.53	.43	.51	.29	.57	.38	
	78.4	.46	.56	.70	.58	.57	.57	.58	.40	.57	.49	
Column 1	2	3	4	5	6	7	8	9	10	11	12	

**Table A-II**

<b>ANGLES OF REPOSE AND EQUIVALENT FLUID DENSITIES FOR SOME GRAINS<sup>(1)</sup></b>		
<b>Grain</b>	<b>Angle of Repose, deg.</b>	<b>Equivalent Fluid Densities (EFD), lb/cu ft</b>
Barley	28	14.4 – 15.6
Corn, shelled	27	18.0
Flaxseed	25	17.5
Oats	32	10.3 – 10.8
Rye	26	18.1
Soybeans	29	16.1
Wheat		
Hard Red Winter	27	18.3
Soft Red Winter	27	19.2
Hard Red Spring	28	18.8
Column 1	2	3

**Note to Table A-II:**

<sup>(1)</sup> From "Grain Storage Loads, Pressures and Capacities, 1969" (see Bibliography).

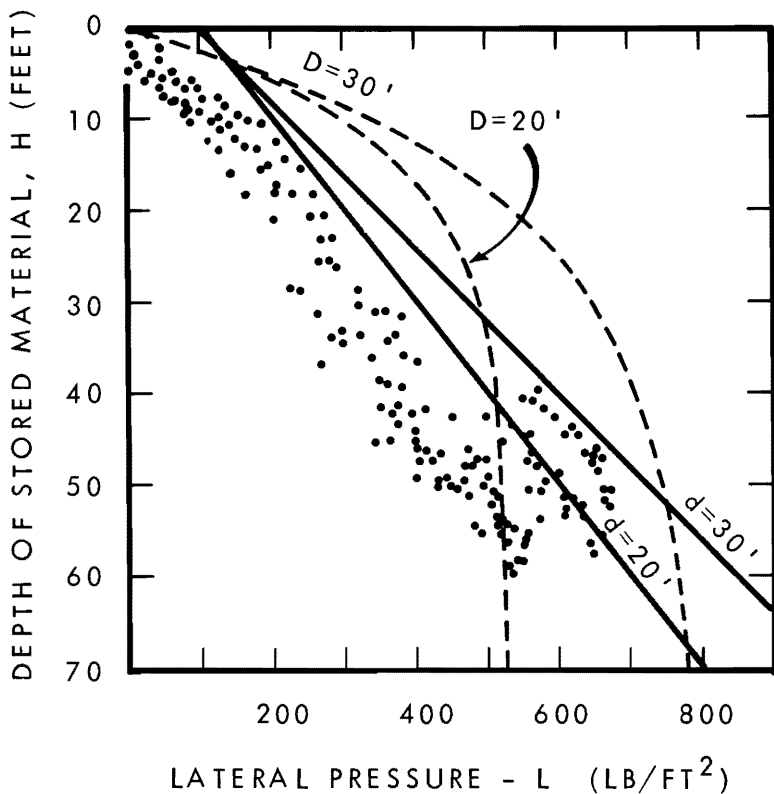

**Figure 1-A** Lateral pressures for corn silage and dry shelled corn

**Notes to Figure 1-A:**

--- Janssen lateral bin pressure for shelled corn

$$L = \frac{WD}{4u'} \left( 1 - e^{-(4Ku'H)/D} \right)$$

Where  $W = 45$  pcf  
 $u' = 0.423$   
 $K = 0.654$

— Formula from Subclause 1.1.2.1.(2)(d)(i)

•••  $L = 100 + 1.92 hd^{0.55}$   
 Boyd, J.S., 1961 (see Bibliography).

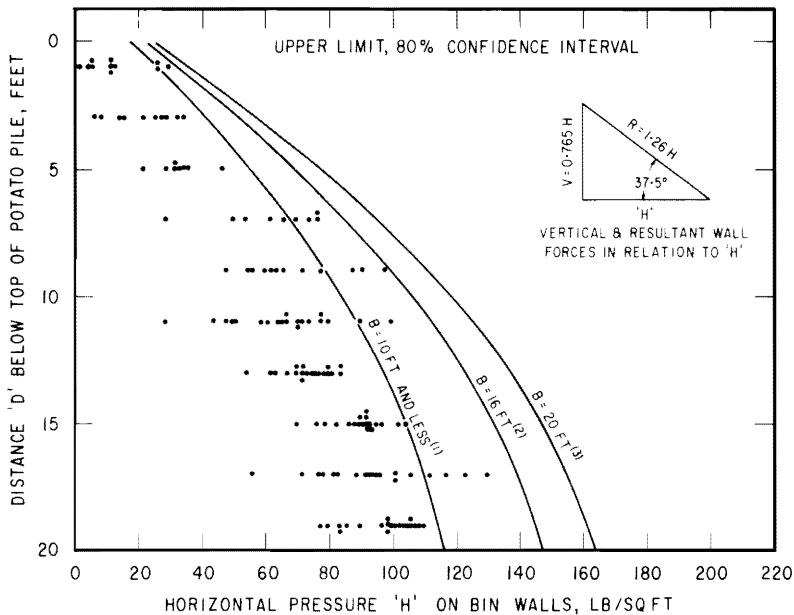

**Figure 2-A** Loads imposed by stored potatoes on bin walls<sup>(1), (2), (3)</sup>

**Notes to Figure 2-A:**

- (1) From Wilson, G.B., 1968 (see Bibliography). For bins 10 ft wide or less,  $H = 17.8 + 8.52D - 0.18D^2$ .
- (2) For bins between 10 and 20 ft wide,  $H = \sqrt{0.1 B} (17.8 + 8.52D - 0.18D^2)$ .
- (3) For bins 20 ft and wider,  $H = \sqrt{2} (17.8 + 8.52D - 0.18D^2)$ .

**APPENDIX B**  
**TABLES OF CONCRETE AND MORTAR MIXES**

**Table B-1**

<b>RECOMMENDED MORTAR MIXES</b>		
Type of Service	Proportions by Volume	
	Cement or/and Lime	Mortar Sand in Damp Loose Condition
For ordinary service	1 masonry cement or 1 portland cement plus 1 hydrated lime	2¼ to 3  4½ to 6
Subject to extreme heavy loads, violent winds or severe frost action, isolated piers	1 masonry cement plus 1 portland cement or 1 portland cement plus ¼ hydrated lime	4½ to 6  3 to 3¼
Column 1	2	3

**Table B-II**

<b>GUIDE FOR ORDERING READY-MIXED CONCRETE<sup>(1)</sup></b>			
<b>Specifications</b>	<b>Maximum Size of Aggregate, in.</b>	<b>Slump, in.<sup>(2)</sup></b>	<b>Minimum 28-Day Compressive Strength, psi</b>
<b>Flat Work</b> Severe exposure (garbage feeding floors, floors in dairy plants)	1½	2-4	4000
Normal exposure (paved barnyards, floors for farm buildings, sidewalks)	1½	2-4	3000
Mild exposure (building footings, concrete improvements in mild climates)	1½	2-4	2500
<b>Formwork</b> Severe exposure (mangers for silage feeding, manure pits)	¾	3-5	4000
Normal exposure (reinforced concrete walls, beams, tanks, foundations)	¾	3-5	3000
Mild exposure (concrete improvements in mild climates)	¾	3-5	2500
Column 1	2	3	4

**Notes to Table B-II:**

- (1) Air-entrained concrete should be ordered for all concrete exposed to freezing, thawing and salt action. For 1½ in. maximum size aggregate, specify 3 to 6 per cent air content, and for ¾ in. and 1 in. maximum size, specify 4 to 7 per cent air content.
- (2) When vibrators are available to consolidate the concrete, these slump values may be reduced by 1 in.



**Table B-III**

<b>RECOMMENDED CONCRETE MIXES FOR ON-THE-JOB MIXING</b>						
Kind of Work	Gallons (Can.) of Water Added to Each 1 Bag Batch if Sand is:		Cement Bags, 80-lb	Aggregates		Approximate Yield, cu ft
	Damp <sup>(1)</sup>	Wet <sup>(2)</sup> (average sand)		Fine, cu ft	Coarse, cu ft	
3½ gallons (Can.) of water per bag of cement. Concrete subjected to severe wear, weather or weak acid and alkali solutions	With ¾ in. max. size aggregate					
	3¼	2¾	1	1¾	2	3.1
4¼ gallons (Can.) of water per bag of cement. Floors (such as basement, dairy barn), driveways, walks, septic tanks, storage tanks, structural beams, columns and slabs	With 1 in. max. size aggregate					
	4   3½	3	1	2	2½	3.7
5 gallons (Can.) of water per bag of cement. Foundation walls, footings, mass concrete, etc.	With 1½ in. max. size aggregate					
	4	3½	1	2¼	3	4.1
Column 1	With 1½ in. max. size aggregate					
	4½	4	1	2½	3½	4.7
	2	3	5	6	7	8

**Notes to Table B-III:**

- (1) Damp describes sand that will fall apart after being squeezed in the palm of the hand.
- (2) Wet describes sand that will ball in the hand when squeezed, but leaves no moisture on the palm.
- (3) Very wet describes sand that has been subjected to a recent rain or recently pumped.
- (4) Mix proportions will vary slightly depending on gradation of aggregates.

**APPENDIX C**  
**FIRE-RESISTANCE RATINGS**

**Table C-I**

<b>ESTIMATED FIRE-RESISTANCE RATINGS FOR FRAME EXTERIOR WALLS<sup>(1)</sup></b>	
Description of Wall Materials and Construction	Fire Resistance, min.
(1) 2 x 4 in. wood studs, 16 in. o.c. Inside finish, <sup>(2)</sup> 3/8 in. Douglas Fir plywood Outside finish, 3/8 in. exterior grade plywood only, or 5/16 in. exterior grade plywood plus building paper and metal, wood or 1/4 in. hardboard siding	25
(2) Same as (1), except inside finish 1/2 in. Douglas Fir plywood, phenolic bonded	30
(3) Same as (1), except inside finish 5/8 in. Douglas Fir plywood, phenolic bonded	35
(4) Same as (1), except inside finish 3/8 in. Douglas Fir plywood, phenolic bonded, over 3/8 in. gypsum wallboard	35
(5) Same as (1), except over 5/8 in. special fire retardant gypsum wallboard <sup>(3)</sup>	60
(6) Same as (1), except inside finish 3/16 in. asbestos-cement board over 3/8 in. gypsum wallboard	60
(7) Same as (1), except add 3 in. mineral wool or glass fibre insulation between studs	40
(8) Same as (4), except add 3 in. mineral wool or glass fibre insulation between studs	50
Column 1	2

**Notes to Table C-I:**

- <sup>(1)</sup> Ratings in this Table are based on the assumption of fire on the inside only. Outside cladding is required only to laterally support the studs and to restrict temperature rise and burn-through after the supporting studding has been exposed to fire by failure of the inside finishes.
- <sup>(2)</sup> Ratings of frame interior walls should normally be based on fire on either side and therefore should have finishes on both sides as per 'inside finish' requirements in this Table.
- <sup>(3)</sup> Fire-retardant gypsum wallboard should be identified by the fire-resistance classification label of Underwriters' Laboratories.

**Table C-II**

<b>ESTIMATED FIRE-RESISTANCE RATINGS FOR MASONRY WALLS</b>	
Description of Wall Materials and Construction	Fire Resistance, hr
(1) Cast-in-place concrete (Type N), <sup>(1)</sup> 1:2½:3½ mix-ratio with or without reinforcement, 6 in. thick	3
(2) Same as (1), except 8 in. thick	5
(3) Hollow concrete unit masonry (Type N), <sup>(1)</sup> 50 per cent min. solid material by volume, 8-in. nominal thickness	1
(4) Hollow concrete unit masonry (Type L), <sup>(2)</sup> 44 per cent min. solid material by volume, 8-in. nominal thickness	3
Column 1	2

**Notes to Table C-II:**

- (1) Type N concrete is that type in which the aggregate is cinders, broken brick, blast furnace slag, limestone, calcareous gravel or similar diverse material containing not over 30 per cent of quartz, chert or flint (SiO<sub>2</sub>).
- (2) Type L concrete is that in which all the aggregate is lightweight, of expanded slag, expanded burned clay or shale or pumice.

**Table C-III**

<b>ESTIMATED FIRE-RESISTANCE RATINGS FOR FLOORS<sup>(1)</sup></b>	
Description of Floor Materials and Construction	Fire Resistance, min.
(1) Reinforced concrete slab, 4 in. of 2000 psi concrete, steel protected by ¾ in. of concrete	75
(2) Same as (1), except 6 in. of concrete and steel protected by 1 in. of concrete	120
(3) Wood joist floor, 2-in. nominal joist thickness, 5/8-in. Douglas Fir plywood on top	10
(4) Wood joist floor, 2 x 10-in. joists 16 in. o.c., 2 ply of ¾-in. lumber on top. Ceiling finished with ¾ in. of plaster on metal lath fastened with barbed roofing nails 6 in. o.c.	60
(5) Same as (3), except ceiling finished with 2 layers of 3/8-in. gypsum wallboard nailed with 1½-in. nails having 3/16-in. heads, at 6 in. o.c.	30
(6) Solid wood laminated mill floor 4-in. nominal thickness, 3/8-in. plywood on top	45
Column 1	2

**Note to Table C-III:**

- (1) Fire-resistance ratings of floor assemblies are based on tests with fire below the floor. No ratings are published for a situation with fire above. Ratings in this Table are probably conservative, however, for the 'fire above' situation.

**APPENDIX D**  
**WATER SUPPLY**

**Table D-I**

<b>FRICTION HEAD LOSS IN FEET OF WATER PER 100 FEET OF STEEL PIPE (Based on C = 100 in Hazen-Williams formula)</b>								
Flow, gal. (U.S.) per min.	Nominal Pipe Size, in.							
	1/2	3/4	1	1¼	1½	2	2½	3
2	7.4	1.9						
4	27.0	7.0	2.14	0.57	0.26			
6	57.0	14.7	4.55	1.20	0.56	0.20		
8	98.0	25.0	7.8	2.03	0.95	0.33	0.11	
10	147.0	38.0	11.7	3.05	1.43	0.50	0.17	0.07
12		53.0	16.4	4.30	2.01	0.79	0.23	0.10
15		80.0	25.0	6.50	3.00	1.08	0.36	0.15
20		136.0	42.0	11.10	5.20	1.82	0.61	0.25
25			64.0	16.60	7.30	2.73	0.92	0.38
30			89.0	31.20	11.00	3.84	1.29	0.54
Column 1	2	3	4	5	6	7	8	9

**Table D-II**

<b>FRICTION HEAD LOSS IN FEET OF WATER PER 100 FEET OF PLASTIC PIPE (Based on C = 150 in Hazen-Williams formula)</b>							
Flow, gal. (U.S.) per min.	Nominal Pipe Size, in.						
	¾	1	1¼	1½	2	2½	3
2	0.90	0.28	0.07				
4	3.28	1.02	0.25	0.12			
6	7.0	2.15	0.55	0.25	0.07		
8	11.8	3.6	0.97	0.46	0.14	0.05	
10	17.9	5.5	1.46	0.69	0.21	0.09	
15	37.8	11.7	3.07	1.45	0.44	0.18	0.07
20		19.9	4.2	2.47	0.74	0.30	0.12
25		30.0	7.9	3.8	1.11	0.46	0.16
30		42.0	11.1	5.2	1.55	0.65	0.23
Column 1	2	3	4	5	6	7	8

**Table D-III**

<b>FRICION HEAD LOSS IN FEET OF WATER PER 100 FEET OF TYPE L COPPER TUBING (Based on C = 130 in Hazen-Williams formula)</b>							
Flow, gal. (U.S.) per min.	Nominal Tubing Size, in.						
	½	¾	1	1¼	1½	2	2½
2	8.89	1.50	0.41				
4	32.0	5.40	1.48				
6	67.7	11.5	3.13	1.12			
8	116.0	19.5	5.35	1.92	0.82		
10	174.0	29.4	8.08	2.90	1.24	0.32	
12		41.2	11.3	4.04	1.73	0.45	
16		70.3	19.2	6.82	2.92	0.77	
20			29.0	10.4	4.46	1.16	0.40
25			43.9	15.7	6.74	1.75	0.61
30			61.4	22.1	9.44	2.45	0.85
Column 1	2	3	4	5	6	7	8

**Table D-IV**

<b>FRICION HEAD LOSS IN VALVES AND FITTINGS<sup>(1)</sup></b>						
Nominal Size, in.	Equivalent Length of Straight Pipe, ft					
	90 deg. Standard Elbow	45 deg. Standard Elbow	Tee, Side Flow	Coupling or Straight Run of Tee	Gate Valve Open	Globe Valve Open
½	2	1.2	3	0.6	0.4	15
¾	2.5	1.5	4	0.8	0.5	20
1	3	1.8	5	0.9	0.6	25
1¼	4	2.4	6	1.2	0.8	35
1½	5	3	7	1.5	1.0	45
2	7	4	10	2.0	1.3	55
2½	8	5	12	2.5	1.6	65
3	10	6	15	3.0	2.0	80
Column 1	2	3	4	5	6	7

**Note to Table D-IV:**

<sup>(1)</sup> From "ASHRAE Guide and Data Book, 1967, Applications," American Society of Heating, Refrigerating and Air-Conditioning Engineers.

**APPENDIX E**  
**DESIGN BEARING PRESSURES**



**Table E-1**

<b>DESIGN BEARING PRESSURES OF SOILS AND ROCK</b> (For buildings 3 storeys or less in height)	
Type and Condition of Soil or Rock	Design Bearing Pressure, psf <sup>(1),(3),(4)</sup>
<b>Cohesionless Soils</b>	
(See Section B, Appendix E, for definitions)	
Dense sand, dense sand and gravel	6,000
Compact sand, compact sand and gravel	3,000
Loose sand, loose sand and gravel	1,000
Very loose sand, very loose sand and gravel	(2)
<b>Cohesive Soils</b>	
(See Section C, Appendix E, for definitions)	
Dense silt	3,000
Compact silt	2,000
Loose silt	(2)
Very stiff clay	6,000
Stiff clay	3,000
Firm clay	1,500
Soft clay	750
Very soft clay	(2)
<b>Miscellaneous Soils and Rock</b>	
(See Section E, Appendix E, for definitions)	
Till, dense or hard	8,000
Till, compact or firm	3,000
Till, soft	(2)
Cemented sand and gravel	10,000
Clay shale	(2)
Filled ground	(2)
<b>Rock</b>	
(See Section F, Appendix E, for definitions)	
Without defects	Up to 20,000
With defects	(2)
Column 1	2

**Notes to Table E-1:**

- (1) Where records of successful local practice can show any of the values that appear in this Table to be either too high or too low, they may be altered by the authority having jurisdiction to suit local conditions.
- (2) Design bearing pressures shall be determined by a special investigation.
- (3) The design capacity of a foundation is the bearing surface area times the design bearing pressure of the soil or rock at the bearing surface, reduced as may be necessary by the requirements contained in Subsection 4.2.4. (Design Requirements) of the National Building Code of Canada 1975.
- (4) For purposes of determining the vertical stress in soils or rock below the bearing surface, the load from the foundation unit shall be assumed to be distributed uniformly over the area of any horizontal plane within a frustum extending downward from the foundation unit perimeter at 60 deg. to the horizontal, but the area considered as supporting the load shall not extend beyond the intersection of 60 deg. planes to adjacent foundation units.

## DEFINITIONS

- A. *Soil* is that portion of the earth's crust which is fragmentary, or such that individual particles of a dried sample may be readily separated by agitation in water; it includes boulders, cobbles, gravel, sand, silt, clay and organic matter.
- B. (1) A cohesionless soil identified as
- (a) *gravel* is a soil consisting of particles smaller than 3 in. but retained on a No. 4 sieve,
  - (b) *sand* is a soil consisting of particles passing a No. 4 sieve but retained on a No. 200 sieve.
- (2) Sands are further subdivided as follows:
- (a) *coarse sand* is a soil consisting of particles passing a No. 4 sieve but retained on a No. 10 sieve,
  - (b) *medium sand* is a soil consisting of particles passing a No. 10 sieve but retained on a No. 40 sieve, and
  - (c) *fine sand* is a soil consisting of particles passing a No. 40 sieve but retained on a No. 200 sieve.
- (3) In addition, particles identified as
- (a) *cobbles* are rock fragments whose greatest dimension is between 3 and 8 in., and
  - (b) *boulders* are rock fragments whose greatest dimension exceeds 8 in.
- C. (1) A cohesionless soil described as
- (a) *dense* requires 30 or more blows per foot in a penetration test,
  - (b) *compact* requires between 10 and 30 blows per foot in a penetration test,
  - (c) *loose* requires between 4 and 10 blows per foot in a penetration test, and
  - (d) *very loose* requires less than 4 blows per foot in a penetration test where the test is carried out in accordance with CSA A119.1-1960, "Code for Split-Barrel Sampling of Soils."
- (2) Where it is not possible to conduct a penetration test, a cohesionless soil may be described as
- (a) *dense* if it is not possible for a man of average weight to push a wooden picket more than 1½ in. into the soil, and
  - (b) *loose* if it is possible for a man of average weight to push a wooden picket 8 in. or more into the soil.
- (3) The picket referred to in (2) is 2 in. square nominal dimensions, bevelled at 45 deg. on all sides at one end to form a point.
- D. (1) A cohesive soil identified as
- (a) *silt* is a soil
    - (i) the particles of which are not visible to the naked eye,
    - (ii) dry lumps of which are easily powdered by the fingers,
    - (iii) that, after shaking a small saturated pat vigorously in the hand, exhibits a wet shiny surface that disappears rapidly when the pat is subsequently squeezed, and
    - (iv) that does not shine when moist and stroked with a knife.
  - (b) *clay* is a soil
    - (i) the particles of which are not visible to the naked eye,
    - (ii) dry lumps of which are not easily powdered by the fingers,
    - (iii) that, after shaking a small saturated pat vigorously in the hand, does not exhibit a wet shiny surface, and
    - (iv) that shines when moist and stroked with a knife.
- E. The consistencies of cohesive soils can be identified according to the description given in Table E-II and may be related to the approximate undrained shear strengths as indicated.
- F. Organic soils and soils other than those identified in Sections B to E require special investigation.
- G. (1) A soil or rock identified as
- (a) *clay-shale* is fine-grained, finely laminated, will swell on wetting and will disintegrate on its first drying and wetting cycle,

Table E-II

IDENTIFICATION OF COHESIVE SOILS		
Consistency	Description	Approximate Undrained Shear Strength, psf
Very stiff	Of a type impossible to indent with the thumb but readily indented with the thumbnail	Over 2000
Stiff	Of a type difficult to indent with the thumb; with difficulty it can be remoulded by hand	1000 to 2000
Firm	Of a type that can be indented by moderate thumb pressure	500 to 1000
Soft	Of a type that can be penetrated several inches with the thumb	250 to 500
Very soft	Of a type that can easily be penetrated several inches by the fist	less than 250
Column 1	2	3

- (b) *till* is of glacial origin, unsorted and heterogeneous and can contain a range of particle sizes from boulders, cobbles, gravel, sands, silts and clays and can exist at any relative density of consistency,
- (c) *cemented sand and gravel* is a mixture of sand and gravel or boulders thoroughly cemented together as a hard layer which will not soften in its natural bed.

- H. (1) *Rock* is that portion of the earth's crust which is consolidated, coherent and relatively hard, and is a naturally formed, solidly bonded, mass of mineral matter which cannot be readily broken by hand.
- (2) Rocks vary from hard through medium hard to soft.
- (a) *Hard* means rock comparable to concrete with a compressive strength greater than 6000 psi.
  - (b) *Medium hard* means rock comparable to concrete with a compressive strength greater than 2500 psi.
  - (c) *Soft* rock is comparable to brick masonry with a compressive strength greater than 500 psi.
- (3) Rocks are classified as
- (a) *igneous* such as granite, diorite, basalt,
  - (b) *sedimentary* such as sandstones, shales, limestones, and
  - (c) *metamorphic* such as quartzites, slates, marbles, schists.
- (4) Rocks may contain defects. Defects which adversely affect the bearing capacity are
- (a) closely spaced, or open, or steeply inclined bedding planes, joints, fault zones, fractures or shear planes,
  - (b) unsoundness, such as closely spaced seams of clay, fault gouge, soil or softened rock, cavities,
  - (c) significant alteration of the strength of the rock by weathering, decomposition or disintegration in the mass or in part, and
  - (d) slaking or swelling behaviour in water.
- (5) Some natural materials which geologically may be correctly referred to as rocks are to be treated as soil under the provisions of this Code. These materials are
- (a) soft rocks with adverse defects,
  - (b) very weakly cemented sedimentary or soft metamorphic rocks which can be scratched by the finger nail,
  - (c) any material which can be dug by hand with a shovel or a pneumatic spade, and
  - (d) cemented sands and gravels in which the cementing may be sporadic.

**APPENDIX F**  
**UNIT WEIGHTS OF MATERIALS**

Table F-1

UNIT WEIGHTS OF CONSTRUCTION MATERIALS AND COMPONENTS	
Materials	Unit Weight, lb/cu ft
Cast stone masonry	144
Cinder fill	57
Concrete	
plain	144
structural lightweight concrete	90-115
slag	132
stone	144
Concrete	
reinforced	150
hollow tile (bearing)	60
Masonry, brick	
hard	130
medium	115
soft	100
Plaster, mortar	96
Timber, seasoned	
Ash, White	41
Douglas Fir	32
Hemlock	28
Pine	30
Spruce	28
Western Cedar	24
Components	Unit Weight, lb/sq ft
Shingle roof, including framing	6-10
Slate roof and framing	12-15
Tar and gravel roof	10-12
Partitions	
wood	15-20
hollow masonry	15-30
Walls	
12-in. concrete blocks	54-97
Floors	
wood	10-15
6-in. concrete	70-80
Walls	
4-in. clay brick	40
4-in. clay tile	18
4-in. concrete brick	
heavy	46
light	33
Walls	
4-in. glass block	18
8-in. clay brick	80
8-in. concrete block	55
light block	35
8-in. clay tile	42
Column 1	2

**Table F-1 (Cont'd)**

Components	Unit Weight, lb/sq ft
12-in. clay tile	58
Wood, 2 x 4, plastered	20
Concrete floor slabs (per inch thickness)	
stone, reinforced	12½
plain	12
Cinder, reinforced	9
Lightweight aggregate	8
Wood-joint floors 16 in.; double wood floor 2 in.	
2 x 5 joists	5
2 x 6 joists	6
2 x 10 joists	6
2 x 12 joists	7
Roof coverings	
aluminum	1/3
asbestos shingles	4
asphalt shingles	3
steel	1
5-ply felt and gravel	6
Lumber	
sheathing (per inch thickness)	3
wood shingles	3
wood shakes	5
Fir plywood (thickness in inches)	
5/16	1.0
3/8	1.2
1/2	1.5
5/8	1.8
3/4	2.2
Phenolic bonded flakeboard (thickness in inches)	
1/4	0.833
5/16	1.041
3/8	1.25
1/2	1.666
5/8	2.083
3/4	2.5
Farm truss roof construction – dead loads	
A – Trusses (4 ft o.c.)	
– Metal roofing	
– No ceiling	4.2
B – Trusses (4 ft o.c.)	
– Metal roofing	
– Insulation and plywood ceiling	5.7
C – Trusses (4 ft o.c.)	
– Asphalt shingles – lumber sheathing	
– Insulation and plywood ceiling	9.2
Column 1	2

Table F-II

APPARENT DENSITIES OF AGRICULTURAL MATERIALS		
Material	Apparent Density, lb/cu ft	Remarks
<b>Grains</b>		
Barley	40	
Flaxseed	45	
Oats	25-35	
ground or rolled	19-25	
Rapeseed		
Polish	40	
Argentine	48	
Rice	36	
Rye	45	
Soybeans	48	
Wheat	48	
Wheat, ground	38	
<b>Corn</b>		
Shelled, 15.5 per cent moisture	45 <sup>(1)</sup>	
24 per cent moisture	46	
28 per cent moisture	46.6	
32 per cent moisture	47.4	
Ground shelled, 15.5 per cent	51	
Husked ear corn	28	Grinding and deep storage increases density approximately 14 per cent over shelled corn. 2 cu ft of ear corn yields approximately 1 cu ft of shelled corn.
Ground ear corn	36	
<b>Concentrated Feeds</b>		
Alfalfa meal, dehydrated	16-22	
Alfalfa pellets	41-43	
Beet pulp, dried	11-16	
Brewers grains		
dried	14-15	
wet	55-60	
Bone meal	50-53	
Fish meal	30-34	
Meat meal	37	
Linseed oil meal	32	
Soya bean oil meal	34-42	
Salt	62-70	
Wheat, bran	11-16	
Wheat middlings	18-25	
Pelleted ration	37-39	
Crumbled ration	34	
<b>Roughage Feeds and Bedding</b>		
Hay		
long	4-5	Use higher values for hay to be dried artificially.
chopped	8-10	
baled		
twine tied	6-8	
wire	10-14	
wafered	20	
Column 1	2	3

Table F-II (Cont'd)

Material	Apparent Density, lb/cu ft	Remarks	
Silage			
stored 8 ft deep, average	35	Moisture content of 70 per cent wet basis <sup>(2)</sup>	
stored 30 ft deep, average	41		
stored 40 ft deep, average	47		
stored 50 ft deep, average	51		
stored 60 ft deep, average	56		
stored 70 ft deep, average	60		
stored 80 ft deep, average	64		
Straw			
long	3.5-4		
chopped	6-8		
loose baled	7-8		
Wood shavings, baled	20		
<b>Fruits and Vegetables</b>			
Apples	38	{ Inside dimensions of box 10½ x 11½ x 18 in.	
Beans			
unshelled	25		
shelled	48		
Carrots	40		
Cherries			
with stems	45		
without stems	51		
Cranberries	30		
Onions, dry	40-46		
Potatoes	42		
Apples (stacked in bushel boxes)	30		
<b>Miscellaneous Products</b>			
Eggs in cases	12		
Tobacco	35		
Wool			
compressed bales	48		
uncompressed bales	13		
Fertilizer	65-70		
Fresh manure (feces and urine mixed)	62		
Portland cement	87-94		
Coal			
anthracite	47-58		
bituminous	40-54		
Column 1	2	3	

**Notes to Table F-II:**

<sup>(1)</sup> A standard bushel is 56 lb of shelled corn at 15.5 per cent moisture and occupies approximately 1.25 cu ft. Increasing moisture content increases both weight and volume of shelled corn.

<sup>(2)</sup> To calculate apparent densities at other moisture contents use the following formula:

$$D = [0.30(D_{70})] / 1 - M$$

where D = other apparent density, lb/cu ft

D<sub>70</sub> = apparent density at 70 per cent wet basis

M = other moisture content, per cent moisture, wet basis

100

= wt of water / wt of wet silage



**APPENDIX G**  
**FARM VEHICLE AND EQUIPMENT STORAGE**

Table G-1

AREAS AND DIMENSIONS OF FARM VEHICLES AND EQUIPMENT				
Item	Length, <sup>(1)</sup> ft	Width, ft	Height, ft	Occupied Area, <sup>(2)</sup> sq ft
Automobile	18	7	6	126
Bale elevator, wheeled, 40 ft	40	7½		80
Bale stooker	6	5½	3½	33
bale wagon, PTO	26½	10½	11½	
bale wagon, SP	25	12	11½	
Baler				
PTO	19½	10½	5½	100
PTO with thrower	24½	10½	7	120
SP	17	10½	8½	100
Combine				
PTO	30	nominal width + 5	12½	250
SP	29	nominal width + 1½	13½ <sup>(3)</sup>	300
Corn picker				
1-row, pull type	10	8	10½	80
2-row, pull type	14	11	10½	132
Corn planter				
2-row, tractor-mounted	6½	5	6	30
4-row, tractor-mounted	6½	12	9	78
4-row, tractor-drawn	10½	12	9	90
6-row, tractor-drawn	12	14	5	
8-row, tractor-drawn (narrow spacing)	12	14	4½	
Cultivator, field				
8 ft tractor-mounted	4	8		25
10 ft tractor-mounted	6½	10		48
16 ft tractor-mounted wheel type	13	16		
20 - 22 ft, tractor-drawn	14 to 17	17 to 19	9	240
26 - 28 ft, tractor-drawn	16	13 to 15	12 to 15	240
Cultivator, row-crop				
2-row, tractor-type demounted				55
4-row	8	15		100
Disc, one-way	14	9		
Discer				
discer (transport) nominal width + 10 ft		9½	4	
duplex (transport) nominal width + 12 ft		11	4	
Column 1	2	3	4	5

Table G-I (Cont'd)

Item	Length, <sup>(1)</sup> ft	Width, ft	Height, ft	Occupied Area, <sup>(2)</sup> sq ft
Disc harrow				
8-ft, tractor-mounted	9½	9	2½	60
8-ft, transport-wheel type	10	9		65
13-ft, transport-wheel type	13	14½	3½	
Feed grinder, mixer unit tractor-drawn, PTO driven	12½	8½	8¾	70
Forage harvester				
tractor-drawn, 2-row corn head	19½	11	11	136
windrow pickup attachment	6	6	4	27
SP	18	11	11	
Forage blower, in transport position				
long hopper type	15½	6	6	80
short hopper type	8½	5½	6	47
Grain, fertilizer drill				
13 x 7, tractor-drawn	9	10	5½	60
15 x 7, tractor-drawn	9	11	5½	50
18 x 7, tractor-drawn	10	12¾	6	80
24 x 7, tractor-drawn	11	18	6	140
Hay conditioner	9	9	4	42
Liquid manure tanker				
800 U.S. gal.	12	7	7½	84
1,400 U.S. gal.	14	8	8½	112
Manure loader, removed from tractor	9	4		36
Manure spreader, tractor, 125 bu.	18½	6½	5½	100
Mower				
horse-drawn, 6-ft bar up	14	5	6½	40
tractor-drawn, 7-ft bar up	7	7	7½	28
tractor rear-mounted, 7-ft bar up	3	5	8	14
tractor mid-mounted, 7-ft bar down	5½	10½		26
7-ft bar down	8	14	3½	
7-ft bar up	8	7	9	
9-ft bar down	8	16	3½	
9-ft bar up	8	7	11	
Mower conditioner	12	11½	4	
Plow, tractor-drawn				
2-furrow mounted	5	3	4	12
5-furrow semi-mounted	21	6	5	100
7-furrow semi-mounted	26	6	5	140
9-furrow semi-mounted	32	6	5	180
Potato digger				
1-row	8	5		40
2-row	27	12	10	175
	27	15	10	200
Column 1	2	3	4	5

Table G-I (Cont'd)

Item	Length, <sup>(1)</sup> ft	Width, ft	Height, ft	Occupied Area, <sup>(2)</sup> sq ft
Potato harvester				
1-row	27	12	10	175
2-row	27	15	10	200
2-, 3- or 4-row (bulk loader in transport position)	25	13	11½ <sup>(4)</sup>	250
Potato sprayer	13	8½	7	110
Potato planter				
1-row	8½	4	5	24
2-row	8½	6	5	36
4-row	12	13	5¼	120
Rake				
12-ft dump rake, horse-drawn	14	14	4½	80
side delivery, tractor-drawn	12	12½	4½	108
rake (reel)	11	11½	4½	
rake (wheel) 6 wheels	14	13	4½	
Rotary-hoe	6	10	3	50
Stalk shredder				
vertical shaft, single rotor, mounted	7	6	3	37
horizontal shaft, with hood, wheeled	9½	9½	10	75
Swather, self-propelled				
10-ft cut	19	11½	6½	190
12-ft cut	19	13½	6½	230
14-ft cut	19	15½	6½	270
16-ft cut	19	17½	6½	300
Tractor				
2 to 3 plow	10	6½	6½	70
3 to 4 plow	13	6½	8½	
3 to 4 plow, row-crop type	12½	7½	7½	
5 plow	13	8 <sup>(5)</sup>	9 <sup>(3)</sup>	
6 plow	13½	8 <sup>(5)</sup>	9½ <sup>(3)</sup>	
7 plow	14	8½ <sup>(5)</sup>	10 <sup>(3)</sup>	
8 plow	14½	8½ <sup>(5)</sup>	10 <sup>(3)</sup>	
8 plow 4 wheel drive	18½	8½ <sup>(5)</sup>	10 <sup>(3)</sup>	
Truck				
pickup, 6½-ft box	16	6½	6	104
pickup, 8-ft box	17½	6½	6	114
livestock rack	26	8	11	208
grain bed	26	8	9	208
Utility blade, tractor rear-mounted	3½	6		12
Column 1	2	3	4	5

**Table G-I (Cont'd)**

Item	Length, <sup>(1)</sup> ft	Width, ft	Height, ft	Occupied Area, <sup>(2)</sup> sq ft
Wagon flat platform self-unloading all-purpose wagon	16 22½	8 8½ (without side extension)	3 11	128 160
self-unloading all-purpose wagon (with cover)	22½	8½	13	54
V-bottom auger wagon (125 bu.)	10	6	12 (with 9 ft auger)	
hoppered grain wagon	10½	7	7 (with 1 ft side extension)	75
Wheeled fertilizer spreader 8-ft spreading width	7	9⅔		48
10-ft spreading width	7	11⅔		58
Windrower, PTO	14	nominal width + 5	5	
Windrower, SP	18	nominal width + 1½	8	
Column 1	2	3	4	5

**Notes to Table G-I:**

- (1) Length of machines includes the length of rigid draw tongues where used. The lengths of swinging tongues, such as on 4-wheeled farm wagons, are not included.
- (2) Occupied area is not necessarily the product of length times width for all machines. Where the occupied area listed is less than the rectangular area, a deduction has been made for that part of the rectangular area which could be used for other storage.
- (3) Add 2 ft for cab.
- (4) With pneumatic stone separator.
- (5) Duals extra.

## **APPENDIX H**

### **JANUARY DESIGN TEMPERATURES (5 PER CENT BASIS)**

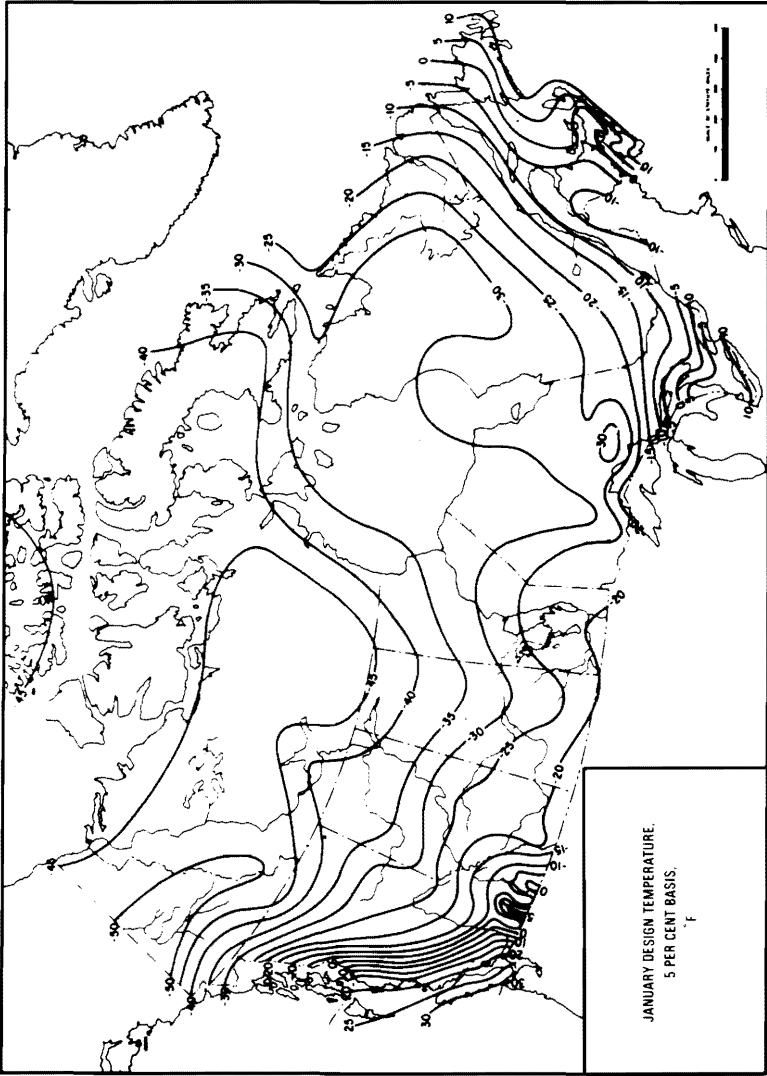

**Figure 1-H** January design temperature (5 per cent basis)

**APPENDIX I**  
**HEAT AND MOISTURE**  
**PRODUCTION AND VENTILATION OF ANIMALS**



Table I-I

OPTIMUM TEMPERATURE RANGE, HEAT AND MOISTURE PRODUCTION OF RABBITS	
Temperature range	50° to 60°F
Sensible heat production (per 5-lb wt)	30 to 40 Btu/hr
Moisture production (per 5-lb wt)	100 to 150 grains/hr
Column 1	2

Table I-II

HEAT PRODUCTION OF BROILER CHICKENS <sup>(1)</sup>							
Dry-Bulb Temperatures Decreasing from 92.2 to 85.9 During Growth							
Age, days	2	11	20	33	40	55	62
Sensible heat <sup>(2)</sup>	6.0	17.7	15.1	11.0	8.2	6.8	6.1
Latent heat <sup>(2)</sup>	6.0	4.1	3.4	3.4	2.6	2.8	2.2
Total heat <sup>(2)</sup>	12.0	21.8	18.5	14.4	10.8	9.6	8.3
Dry-Bulb Temperatures Decreasing from 95.2 to 53.3 During Growth							
Age, days	3	14	20	31	40	50	
Sensible heat <sup>(2)</sup>	16.7	23.0	17.9	13.1	11.3	13.9	
Latent heat <sup>(2)</sup>	1.1	3.3	2.6	2.8	2.7	2.3	
Total heat <sup>(2)</sup>	17.8	26.3	20.5	15.9	14.0	16.2	
Column 1	2	3	4	5	6	7	8

**Notes to Table I-II:**<sup>(1)</sup> From Ota, H. and McNally, E.H., 1965 (see Bibliography).<sup>(2)</sup> Btu/hr/lb of live weight.

Table I-III

HEAT PRODUCTION OF SHORTHORN HEIFERS GROWING AT 50°F AND 80°F						
Age, months		Weight, lb	Heat Production			
			at 50°F <sup>(1)</sup>		at 80°F	
At 50°F	At 80°F		Total Heat, <sup>(2)</sup> Btu/animal-hr	Latent/Total <sup>(3)</sup> Ratio	Total Heat, <sup>(2)</sup> Btu/animal-hr	Latent/Total <sup>(3)</sup> Ratio
2	2.3	110	646	0.27	584	0.54
5	7.1	276	1360	0.25	1250	0.49
8.5	12.9	496	1630	0.25	1490	0.53
12.2	16.4	661	1790	0.25	1690	0.57
16.4		827	1930	0.26		
17.7		882	1970	0.26		
Col. 1	2	3	4	5	6	7

**Notes to Table I-III:**<sup>(1)</sup> Data for 50°F taken at approximately 62 per cent relative humidity.<sup>(2)</sup> From Kibler, H.H., 1957 (see Bibliography).<sup>(3)</sup> From Kibler, H.H. and Yeck, R.G., 1959 (see Bibliography).

**Table I-IV**

<b>GENERAL VENTILATION RECOMMENDATIONS (CFM PER UNIT)</b>					
Type of Livestock/Poultry	Type of Housing	Step 1. Continuous	Step 2. Moisture Control	Step 3. <sup>(1)</sup> Temperature Control	Total Ventilation Required, cfm per unit
<b>Dairy</b>					
1,000-lb cow	Walls with insulation R < 5. Single glazed windows. Ventilation by windows or doors during summer	20	20	100	140 cfm/1000 lb
1,000-lb cow	Year-round well insulated R > 10, housing with non-opening windows	25	25	200	250 cfm/1000 lb
<b>Calves</b> (Winter temp. controlled 45 to 60°F)					
<b>Continuous housing</b>					
110-lb average calf (1 month)	Year-round housing in well-insulated barn	7	7	36	50 cfm/calf
140-lb average calf (2 month)		10	10	50	70 cfm/calf
<b>Batch housing</b>					
100-lb calf (at start)		5	5	40	50 cfm/calf
300-lb calf (at finish)		12	12	100	124 cfm/calf
<b>Beef</b>					
1,000-lb cow	Walls with insulation R < 5. ventilation by windows and doors during summer	20	20	100	140 cfm/1000 lb
<b>Poultry</b>					
Laying hens	Cages, bird density about 0.5 sq ft/bird	0.5	0.5	6.5	7.5 cfm/hen
	Litter—high bird density (1.25 sq ft or less/hen)	0.5	0.5	4	5 cfm/hen
	Litter—low bird density	0.5	0.5	3	4 cfm/hen
Breeder hens	Litter or mesh floor	0.5	0.5	5	6 cfm/hen
Started pullets	1 or 2 deck cages	0-0.5	0.5-1	4	5 cfm/pullet
Broilers	Litter—high bird density (1.0 sq ft or less/bird)	0-0.5	0.5-1	4	5 cfm/broiler at 4 lb
<b>Turkeys</b>					
	Multi-purpose	0.125	0.125	1	1.25 cfm/lb
	Turkey barns	0.5	0.5	4	5 cfm/sq ft (min.)
<b>Swine</b>					
Dry sow	Gestation barn ventilation by windows during summer	10	10	80	100 cfm/sow
	year-round housing in windowless barn or barn with non-opening windows	10	10	130	150 cfm/sow
Sow and litter	Farrowing barn year-round insulated housing	15	15	250	280 cfm/sow
Weanlings	Weanling barn (15 to 50 lb)	2.0	2.0	28	32 cfm/pig
Growers <sup>(2)</sup>	Growing barn (50 to 125 lb)	2.5	2.5	40	45 cfm/pig <sup>(2)</sup>
Finishers <sup>(2)</sup> (125 to 200 lb)	High density (8 sq ft or less)	3	3	74	80 cfm/pig <sup>(2)</sup>
	Lower density (above 8 sq ft/pig)	3	3	64	70 cfm/pig <sup>(2)</sup>
Growing-finishing (average wt 125 lb)	High density (8 sq ft or less)	3	3	54	60 cfm/pig <sup>(3)</sup>
	Lower density (above 8 sq ft/pig)	3	3	44	50 cfm/pig <sup>(3)</sup>
<b>Horses</b>					
1,000-lb horse	Year-round insulated stabling, ventilated by windows and doors during summer	20	20	100	140 cfm/1000 lb
<b>Sheep</b>					
100-lb ewe	Walls with insulation R < 5. ventilated by windows and doors during summer	2	2	11	15 cfm/100 lb
<b>Rabbits</b>					
Doe and litter	30 lb/cage	0.125	0.125	1.0	1.25 cfm/lb
	Lower density	0.075	0.075	0.75	0.9 cfm/lb
<b>Chinchillas</b>	Year-round insulated housing (in cages)	0.125	0.125	2.25	2.5 cfm/mature animal
Column 1	2	3	4	5	6

**Notes to Table I-IV:**

- (1) Step 3 for temperature control should be in 2 or 3 stages when possible.
- (2) When separate growing and finishing units are used for "batch housing."
- (3) When one unit is used for growing and finishing on a continuous basis.

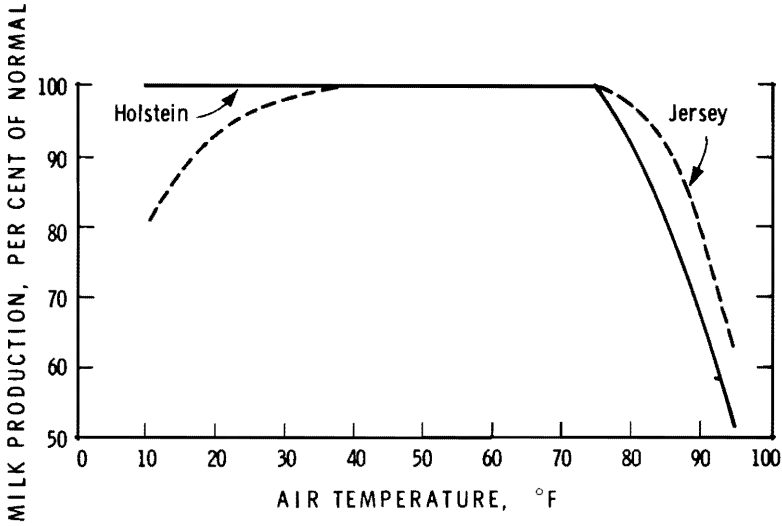

**Figure 1-1** Milk production versus temperature<sup>(1)</sup>

**Note to Figure 1-1:**

<sup>(1)</sup> From Yeck, R.G. and Stewart, R.E., 1959 (see Bibliography). (Per cent of normal milk production at various environmental temperatures. The relative humidity ranged from 55 to 70 per cent.)

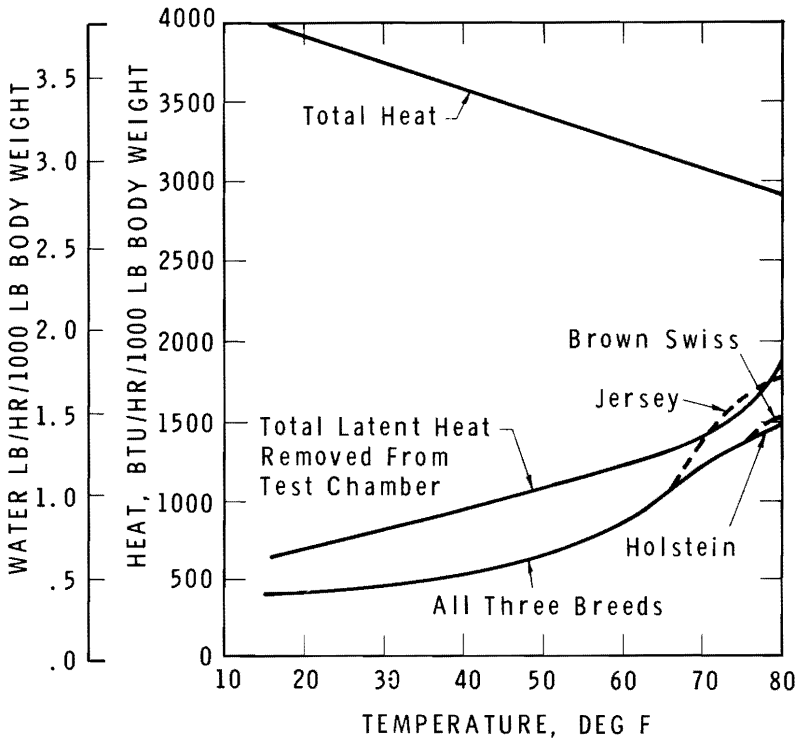

**Figure 2-I** Total and latent heat production of cattle<sup>(1)</sup>

**Note to Figure 2-I:**

<sup>(1)</sup> From Yeck, R.G. and Stewart, R.E., 1959 (see Bibliography).

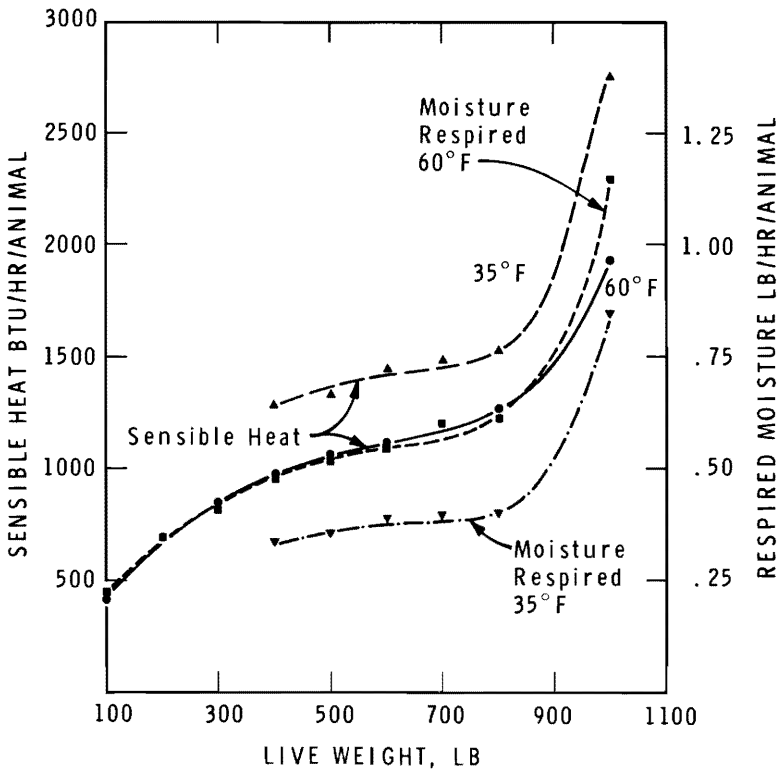

**Figure 3-I** Heat and moisture production from growing cattle, winter conditions

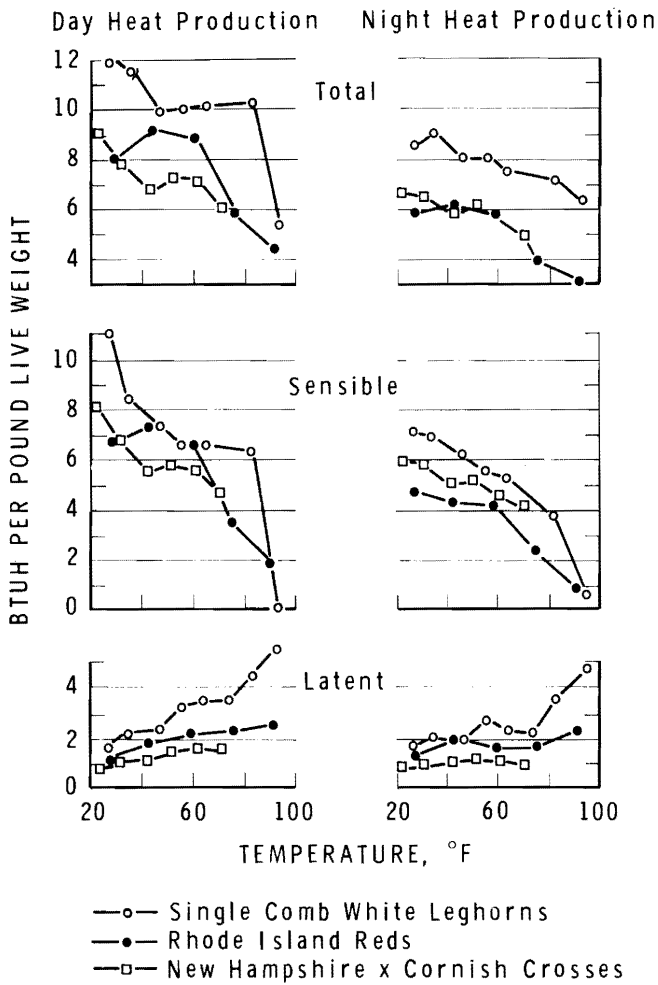

**Figure 4-1** Heat and moisture loads for caged laying hens at various air temperatures<sup>(1)</sup>

**Notes to Figure 4-1:**

<sup>(1)</sup> From Ota, H. and McNally, E.H., 1961 (see Bibliography).

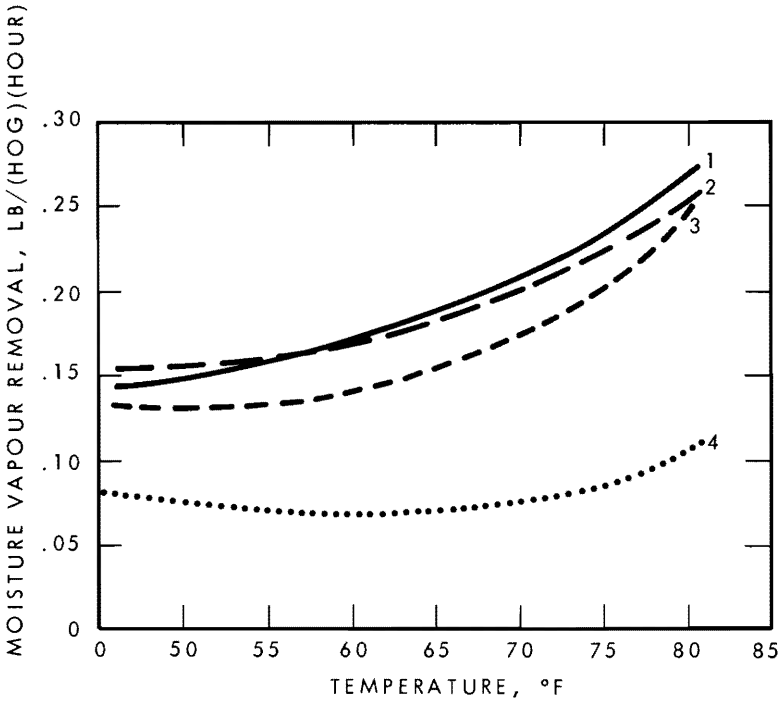

**Figure 5-1** Moisture removal rate versus temperature for swine<sup>(1) to (4)</sup>

**Notes to Figure 5-1:**

- (1) Bond, T.E., Kelly, C.F. and Heitman, H., 1959, for concrete floor (average 0.185 lb/(hog)(hour)).
- (2) Harman, D.J., Dale, A.C. and Jones, H.W., 1968, for concrete floor (average 0.190 lb/(hog)(hour)).
- (3) Harman, D.J., Dale, A.C. and Jones, H.W., 1968, for 35 per cent slotted floor (average 0.16 lb/(hog)(hour)).
- (4) Harman, D.J., Dale, A.C. and Jones, H.W., 1968, for slotted floor (average 0.08 lb/(hog)(hour)).

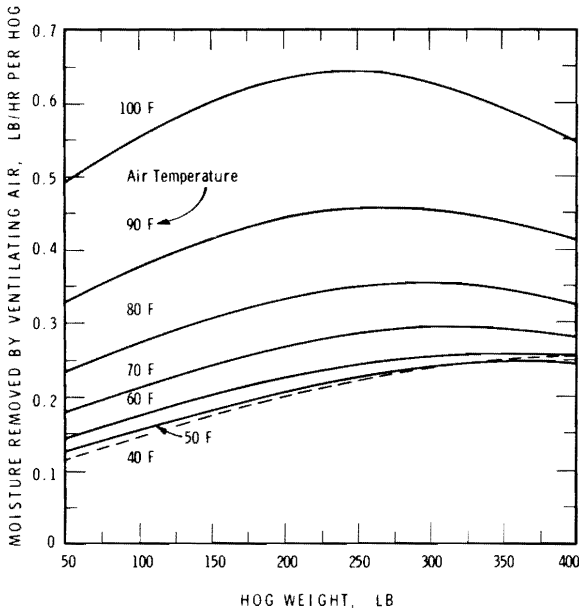

**Figure 6-I** Total moisture removed by ventilation system of test room housing swine

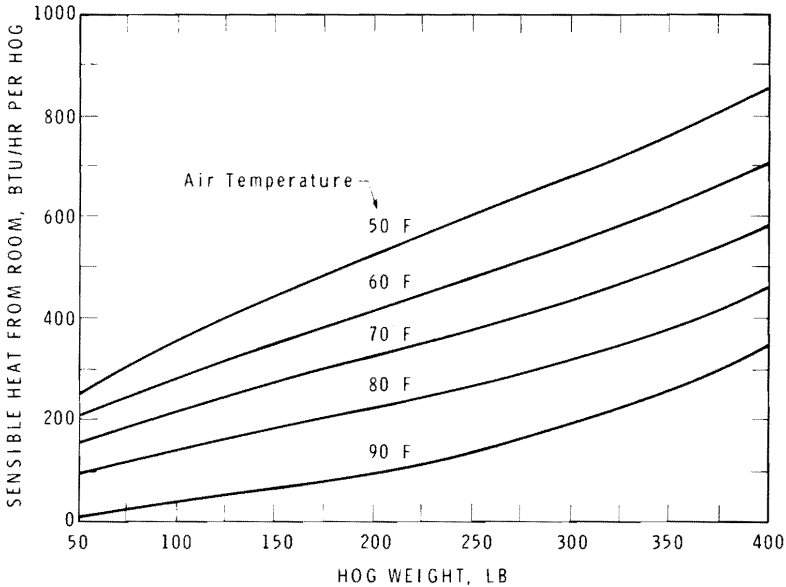

**Figure 7-I** Curves for estimating the room sensible heat in a hog house on the basis of animal size and room temperature<sup>(1)</sup>

**Note to Figure 7-I:**

<sup>(1)</sup> From Bond, T.E., Kelly, C.F. and Heitman, H. Jr., 1959 (see Bibliography).



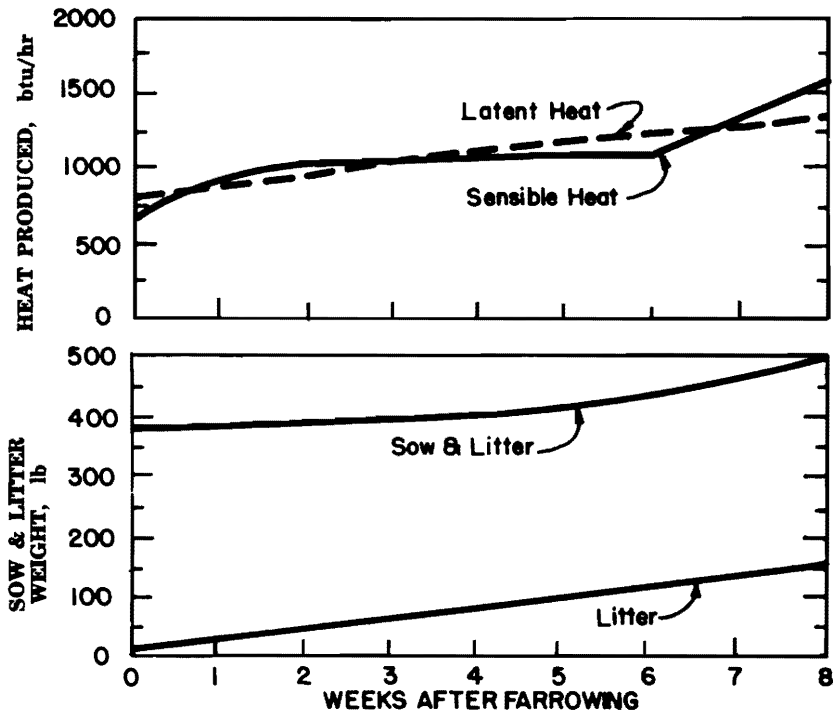
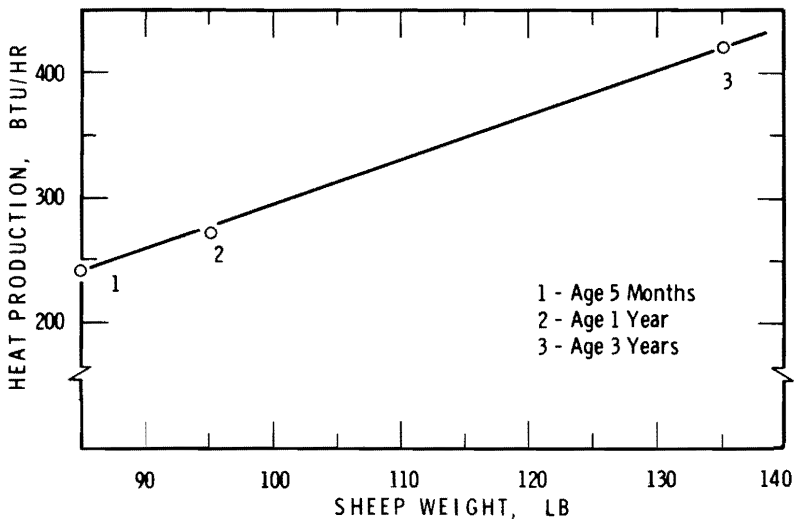

Figure 8-1 Building sensible and latent heat, and animal weight for sows and litters<sup>(1)</sup>

Note to Figure 8-1:

<sup>(1)</sup> From Bond, T.E., Kelly, C.F. and Heitman, H. Jr., 1952 (see Bibliography). (Heat and moisture production were measured at environmental temperatures of 50, 60 and 70°F and then averaged.)



**Figure 9-1** Effect of sheep weight upon heat production at air temperature of 70 to 72°F<sup>(1)</sup>

**Note to Figure 9-1:**

<sup>(1)</sup> From Reitzman, E.G. and Benedict, F.G., 1930; Reitzman, E.G. and Benedict, F.G., 1931; and Armstrong, D.G. et al, 1959 (see Bibliography).

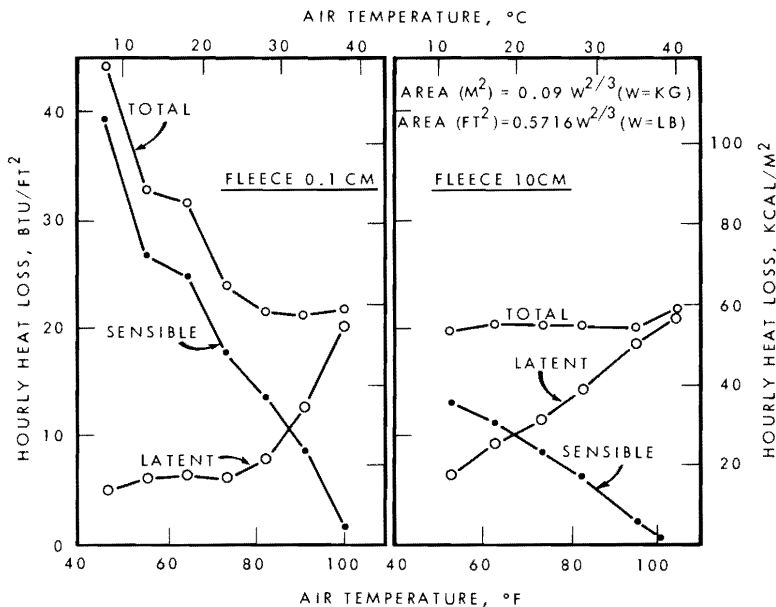

**Figure 10-1** Effect of environment and fleece length on heat losses from sheep (half bred x Dover-Cross wethers).<sup>(1), (2)</sup>

**Note to Figure 10-1:**

<sup>(1)</sup> Relative humidity 45-54 per cent. Air flow 4 cfm (1.91 litres/sec.).

<sup>(2)</sup> From Blaxter, K.L., Graham, M.N. and Wainman, F.W., 1959 (see Bibliography).

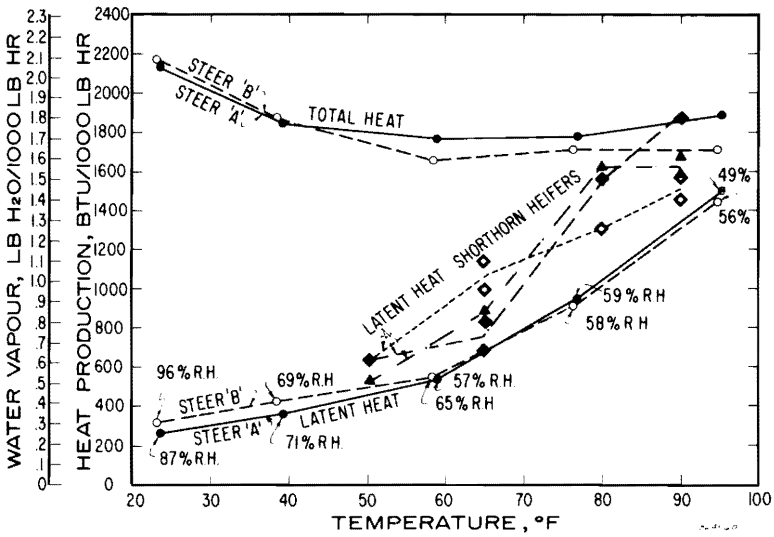
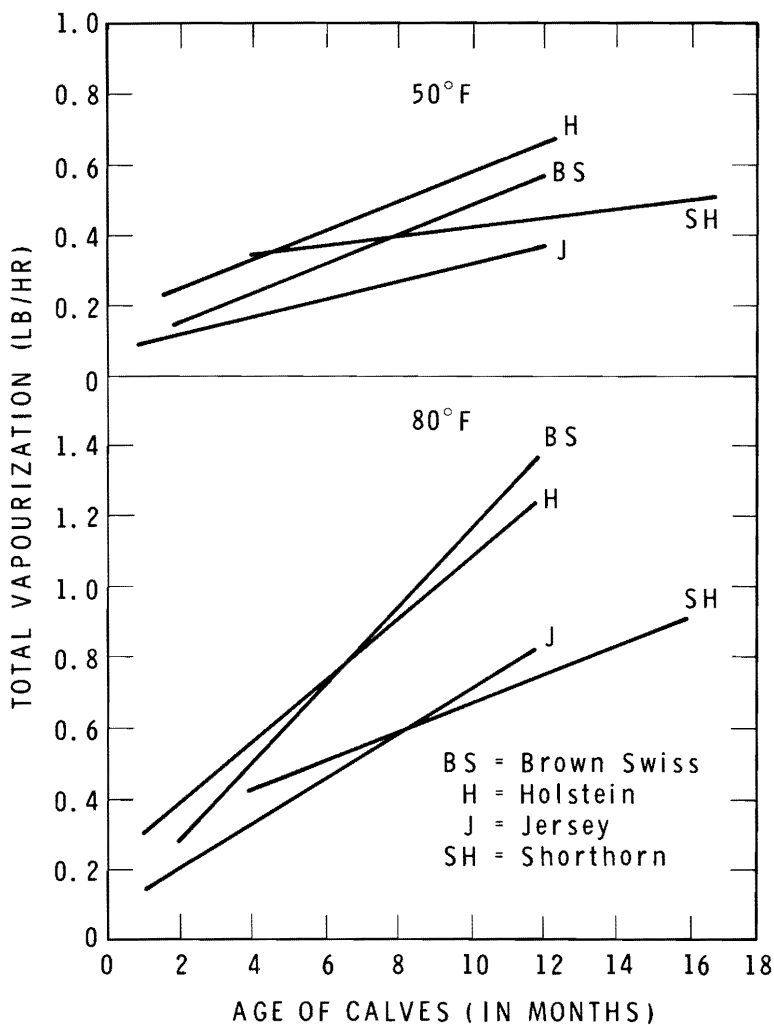

Figure 11-I Total and latent heat production of steers and heifers in relation to temperature<sup>(1)</sup>

**Note to Figure 11-I:**

(1) Curves for Steer 'A' and Steer 'B' were redrawn from the paper by Blaxter, K.L. and Wainman, F.W., 1961 (see Bibliography). Steers were Aberdeen Angus on maintenance ration and weighed between 1120 and 1175 lb each. Latent heat curves for Shorthorn heifers were redrawn from the paper by Kibler, H.H. and Yeck, R.G., 1959 (see Bibliography).



**Figure 12-1** Total vapourization related to age for Holstein, Jersey, Brown Swiss and Shorthorn calves grown at 50 and 80°F<sup>(1)</sup>

**Note to Figure 12-1:**

<sup>(1)</sup> From Kibler, H.H., Yeck, R.G. and Berry, I.L., 1962 (see Bibliography).

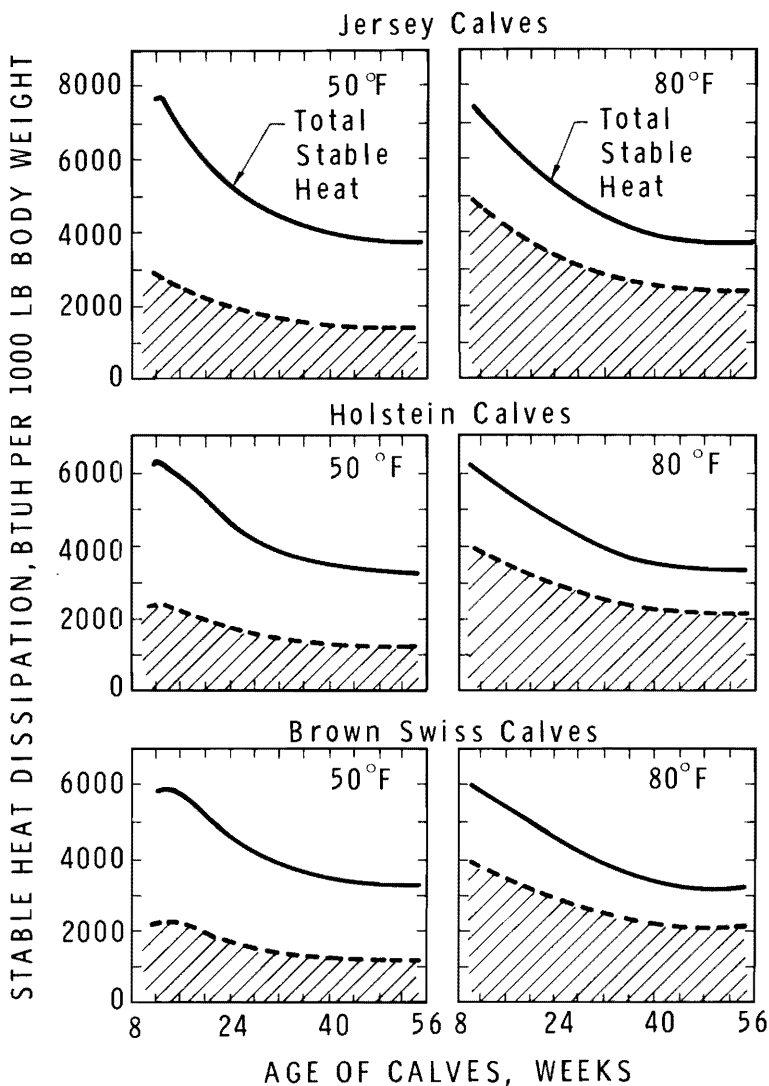

**Figure 13-1** Stable heat (total heat) and latent heat produced by dairy calves<sup>(1), (2)</sup>

**Notes to Figure 13-1:**

- (1) Relative humidities were approximately 70 per cent at 50°F and 50 per cent at 80°F. Calves were housed in pens cleaned daily.
- (2) From Yeck, R.G. and Stewart, R.E., 1960 (see Bibliography).

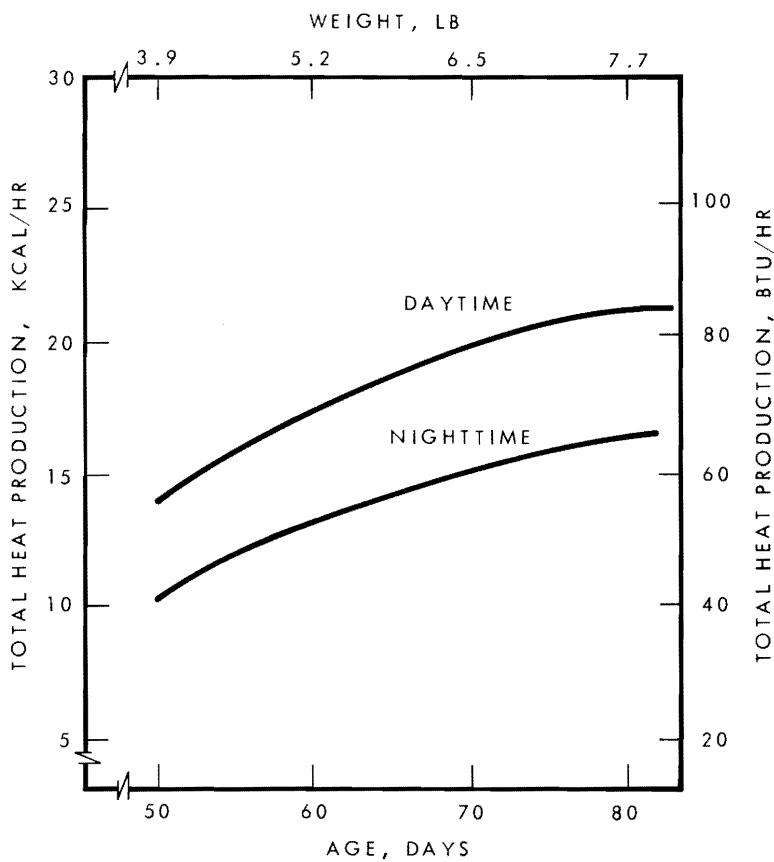

**Figure 14-1** Total heat production of growing turkeys<sup>(1)</sup>

**Note to Figure 14-1:**

<sup>(1)</sup> From Buffington, D.E., Jordon, K.A. and Boyd, L.L., 1972 (see Bibliography).

## **APPENDIX J**

### **HEAT OF RESPIRATION OF STORED PRODUCTS**



Table J-1

## HEAT OF RESPIRATION OF VEGETABLES

Vegetable	Average Freezing Point, °F	Water, per cent	Specific Heat, Btu/lb, °F		Latent Heat of Fusion, Btu/lb	Heat of Respiration	
			Above Freezing	Below Freezing		°F	Btu/(24 hr) (ton)
Artichokes	29.1	83.7	0.87	0.45	120	40	10,140
Asparagus	29.8	93	0.94	0.48	134	40	11,500
Beans, string	29.7	88.9	0.91	0.47	128	32	5,800
Beans, Lima	30.1	66.5	0.73	0.40	94	40	10,600
						32	2,350
						40	5,000
						60	25,000
Beans, dried					18	—	—
Beets	26.9	12.5 90	0.30 0.86	0.24 0.47	129	32	2,650
						40	4,060
						60	7,200
Broccoli	29.2	89.9	0.92	0.47	130	32	7,450
						40	17,000
						60	50,000
Brussels sprouts	31	84.9	0.88	0.46	122	—	—
Cabbage	31.2	92.4	0.94	0.47	132	32	1,200
						40	1,700
						60	4,100
Carrots	29.6	88.2	0.86	0.45	126	32	2,130
						40	3,470
						60	8,100
Cauliflower	30.1	91.7	0.93	0.47	132	32	2,000
						40	4,500
						60	10,000
Celery	29.7	93.7	0.95	0.48	135	32	1,620
						40	2,420
						60	8,200
Column 1	2	3	4	5	6	7	8

Table J-1 (Cont'd)

Vegetable	Average Freezing Point, °F	Water, per cent	Specific Heat, Btu/lb, °F		Latent Heat of Fusion, Btu/lb	Heat of Respiration	
			Above Freezing	Below Freezing		°F	Btu/(24 hr) (ton)
Corn, green	28.9	75.5	0.80	0.43	108	32	9,000
Corn, dried	-	10.5	0.28	0.23	15	40	12,000
Cucumbers	30.5	96.1	0.97	0.49	137	60	38,000
Eggplant	30.4	92.7	0.94	0.47	132	-	-
Endive (escarole)	30.9	93.3	0.94	0.48	132	-	-
Horseradish	26.4	73.4	0.78	0.42	104	-	-
Kale	30.7	86.6	0.89	0.46	124	-	-
Kohlrabi	30	90	0.92	0.47	128	-	-
Lettuce	31.2	94.8	0.96	0.48	136	32	11,320
Lettuce, leaf						40	15,990
						32	4,500
						40	6,400
						60	14,000
Mushrooms	30.2	91.1	0.93	0.47	130	32	6,200
						40	12,000
						60	46,000
Onions	30.1	87.5	0.91	0.46	124	32	1,000
						40	1,800
						60	2,400
Parsnips	30	78.6	0.84	0.46	112	-	-
Peas, green	30	74.3	0.79	0.42	106	32	8,400
						40	16,000
						60	44,000
Column 1	2	3	4	5	6	7	8



Table J-II

HEAT OF RESPIRATION OF MISCELLANEOUS FARM PRODUCTS AND BYPRODUCTS							
Product	Average Freezing Point, °F	Water, per cent	Specific Heat, Btu/lb., °F		Latent Heat of Fusion, Btu/lb	Heat of Respiration	
			Above Freezing	Below Freezing		°F	Btu/(24 hr) (ton)
Butter	30-0	15	0.64	0.34	15	-	-
Cheese, American	17	60	0.64	0.36	79	40	4,680
Cheese, Camembert	18	60	0.70	0.40	86	40	4,920
Cheese, Limburger	19	55	0.70	0.40	86	40	4,920
Cheese, Roquefort	3	55	0.65	0.32	79	45	4,000
Cheese, Swiss	15	55	0.64	0.36	79	40	4,660
Cream, 40 per cent	28	73	0.85	0.40	90	-	-
Eggs, crated	27	-	0.76	0.40	100	-	-
Eggs, frozen	27	-	-	0.41	100	-	-
Honey	-	18	0.35	0.26	26	40	1,420
Hops	-	-	-	-	-	35	1,500
Maple sugar	-	5	0.24	0.21	7	45	1,420
Maple syrup	-	36	0.49	0.31	52	45	1,420
Milk	31	87.5	0.93	0.49	124	-	-
Nuts, dried	-	3-10	0.21-0.29	0.19-0.24	4.3-14	-	-
Tobacco and cigars	25	-	-	-	-	35	1,000
Column 1	2	3	4	5	6	7	8

Table J-III

HEAT OF RESPIRATION OF STORED FRUITS <sup>(1)</sup>							
Fruit	Average Freezing Point, °F	Water, per cent	Specific Heat, Btu/lb, °F		Latent Heat of Fusion, Btu/lb	Heat of Respiration	
			Above Freezing	Below Freezing		°F	Btu/(24 hr) (ton)
Apples	28.4	84.1	0.86	0.45	121	32	900 1,600 7,000
Apricots	28.1	85.4	0.88	0.46	122	—	—
Blackberries	28.9	85.3	0.88	0.46	122	—	—
Blueberries	28.6	82.3	0.86	0.45	118	32	2,000 3,500
Cantaloupes	29	92.7	0.94	0.48	132	60	10,000 3,470
Cherries	26	83	0.87	0.45	120	60	8,080 1,700 2,500 12,000
Cranberries	27.3	87.4	0.90	0.46	124	32	650
Currants	30.2	84.7	0.88	0.45	120	—	—
Gooseberries	28.9	88.3	0.90	0.46	126	—	—
Grapes	26.3	81.7	0.86	0.44	116	32	600 1,200 3,500
Honeydew melon	20	92.6	0.94	0.48	132	60	1,300 8,500
Peaches	29.4	86.9	0.90	0.46	124	32	1,300 2,000 9,000
Column I	2	3	4	5	6	7	8

Table J-III (Cont'd)

Fruit	Average Freezing Point, °F	Water, per cent	Specific Heat, Btu/lb, °F		Latent Heat of Fusion, Btu/lb	Heat of Respiration	
			Above Freezing	Below Freezing		°F	Btu/(24 hr) (ton)
Pears	28.5	83.5	0.86	0.45	118	32	900
Plums	28	85.7	0.88	0.45	123	40	1,700
Raspberries	30.1	82	0.85	0.45	122	60	10,000
Strawberries	29.9	90	0.92	0.47	129	32	700
Watermelons	29.2	92.1	0.97	0.48	132	40	1,500
Column 1	2	3	4	5	6	7	8
							2,800
							5,000
							8,000
							22,000
							3,800
							6,800
							20,000

**Note to Table J-III:**

(1) From "The Commercial Storage of Fruits, Vegetables and Florist and Nursery Stocks," U.S.D.A. Agricultural Handbook No. 66, 1954.

**APPENDIX K**  
**VENTILATION**





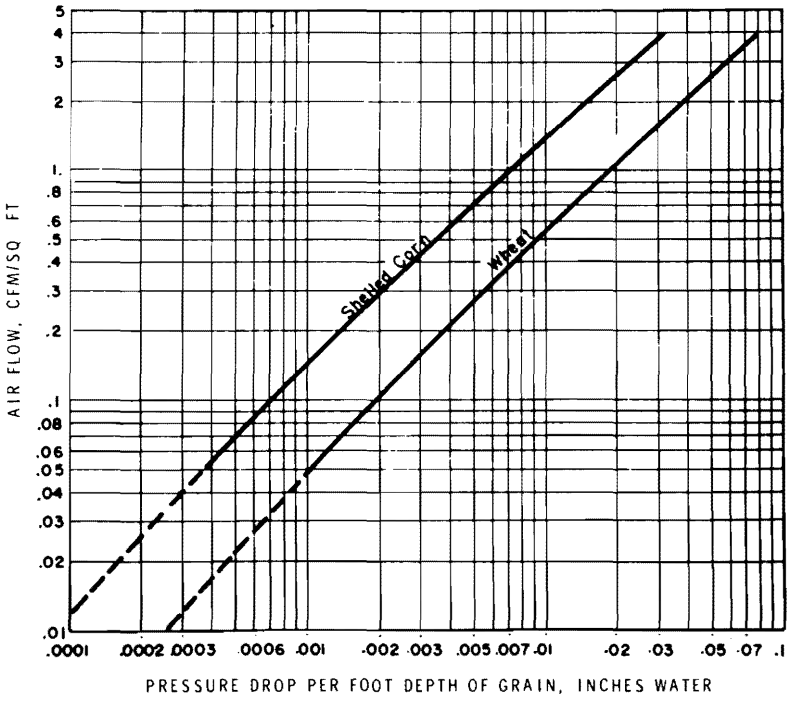

**Figure 2-K** Resistance of shelled corn and wheat to low air flows

**APPENDIX L**  
**ELECTRICAL SERVICES**

Table L-1

**COPPER CONDUCTOR SIZES FOR 2 PER CENT DROP IN POTENTIAL ON 110-120 VOLTS,  
2 CONDUCTORS <sup>(1) to (4)</sup>**

Current, amp	Approximate Distance in Feet to Centre of Distribution																						
	20	30	40	50	60	70	80	90	100	120	140	160	180	200	240	280	320	360	400	450	500		
	Copper Conductor Sizes in AWG, Calculated for Conductor Temperature of 60°C and Ambient of 30°C																						
1	--	--	--	--	--	--	--	--	--	--	--	--	--	--	--	--	--	--	--	14			
1½	--	Minimum allowable wire size is # 14 AWG								--	--	--	--	--	--	14	12	12	12	12	12	12	
2	--	Minimum allowable wire size is # 14 AWG								--	--	--	--	--	14	12	12	12	10	10	10	10	
3	--	Minimum allowable wire size is # 14 AWG								--	--	14	12	12	12	10	10	10	10	8	8	8	8
4	--	--	--	--	--	--	--	14	12	12	12	10	10	10	8	8	8	8	8	8	8		
5	--	--	--	--	--	14	12	12	12	10	10	10	10	8	8	8	8	6	6	6	6		
6	--	--	--	--	14	12	12	12	10	10	10	10	8	8	8	8	6	6	6	6	6		
7	--	--	--	14	12	12	12	10	10	10	10	8	8	8	8	6	6	6	5	5	5		
8	--	--	14	12	12	12	10	10	10	10	8	8	8	8	6	6	6	5	5	4	4		
9	--	14	12	12	12	10	10	10	10	8	8	8	8	6	6	6	5	5	4	4	3		
10	--	14	12	12	10	10	10	10	8	8	8	8	6	6	6	5	5	4	4	3	3		
12	--	14	12	12	10	10	10	8	8	8	8	6	6	6	5	5	4	4	3	3			
14	14	14	12	10	10	10	8	8	8	8	6	6	6	5	5	4	3	3	2	2			
16	12	12	12	10	10	8	8	8	8	6	6	6	5	5	3	3	3	2	2	1	1		
18	12	12	10	10	10	8	8	8	6	6	6	5	5	4	4	3	2	2	1	1			
20	12	12	10	10	8	8	8	6	6	6	5	5	4	4	3	2	2	1	1	1/0	1/0		
25	10	10	10	8	8	6	6	6	6	5	5	4	3	3	2	1	1	1/0	1/0	1/0	2/0		
30	10	10	8	8	6	6	6	6	5	4	4	3	3	2	1	1	1/0	2/0	2/0	2/0			
35	8	8	8	8	6	6	5	5	4	4	3	2	2	1	1	1/0	2/0	2/0	3/0	3/0			
40	8	8	8	6	6	5	5	4	4	2	2	2	1	1	1/0	2/0	2/0	3/0	3/0	4/0	4/0		
45	--	--	--	6	5	--	4	--	4	--	3	2	--	1	--	2/0	--	3/0	--	4/0			
50	--	8	--	6	5	--	4	--	3	2	--	1	--	1/0	2/0	--	3/0	--	4/0				
60	--	--	6	5	--	4	--	3	2	--	1	--	1/0	2/0	--	3/0	--	4/0					
70	--	--	--	4	3	--	2	--	1	1/0	--	2/0	--	3/0	4/0								
80	--	6	5	4	--	2	--	1	--	--	2/0	--	3/0										
90	--	--	--	3	2	--	1	--	1/0	2/0	--	3/0	--	4/0									
100	--	5	--	3	2	--	1	--	1/0	2/0	--	3/0	--	4/0									
125	--	--	--	2	1	--	1/0	--	2/0	3/0	--	4/0											
150	--	--	--	1	--	1/0	2/0	--	3/0	--	4/0												
175	--	--	--	--	1/0	2/0	--	3/0	--	4/0													
200	--	--	--	--	--	2/0																	
250	--	--	--	--	--	3/0	4/0																
300	--	--	--	--	--	4/0																	
Col. 1	2	3	4	5	6	7	8	9	10	11	12	13	14	15	16	17	18	19	20	21	22		

Notes to Table L-1:

- (1) This Table is calculated for wire sizes No. 14 to No. 4/0 AWG and gives for each size specified the approximate maximum distance in feet to the centre of distribution for a 2 per cent drop in potential at a given current. Inductive reactance has not been included, since it is a function of conductor size and spacing.
- (2) This Table is based on conductor resistance at 60°C. For conductor temperatures above 60°C multiply distances in feet in the column headings by a factor as follows to retain 2 per cent drop in potential.

Conductor Temperature	Distance Correction Factor
75°C	0.94
85-90°C	0.90
110°C	0.83
125°C	0.79
200°C	0.64

- (3) For 220-240 volts multiply the distances in feet in the column headings by 2 for the same percentage drop.
- (4) Example on use of Table:  
Example: Consider a 2-conductor circuit carrying 10 amp at 110-120 volts. From the Table opposite "10 amps" it will be found that a No. 14 AWG circuit can be run 40 ft from the centre of distribution to the load without exceeding a 2 per cent drop. Beyond this distance a larger size of conductor is required (i.e. No. 12 AWG beyond 40 ft up to and including 60 ft).

**Table L-II**

<b>ALLOWABLE AMPACITIES FOR NOT MORE THAN 3 COPPER CONDUCTORS IN RACEWAY OR CABLE (Based on Ambient Temperature of 30°C (86°F)<sup>(1)</sup>)</b>						
<b>Size, AWG MCM</b>	Allowable Ampacity					
	60°C	75°C	85-90°C	110°C	125°C	200°C
	Types R60, RW60, T, TW	Types R75, RW75, TWH	Types R90, V, RW90, A-18, NMD-7 Paper Mineral-Insulated Cable	Types A-1, A-2 A-9, A-20	(2)	(2)
14	15	15	15	30	30	30
12	20	20	20	35	40	40
10	30	30	30	45	50	55
8	40	45	50	60	65	70
6	55	65	70	80	85	95
4	70	85	90	105	115	120
3	80	100	105	120	130	145
2	100	115	120	135	145	165
1	110	130	140	160	170	190
0	125	150	155	190	200	225
00	145	175	185	215	230	250
000	165	200	210	245	265	285
0000	195	230	235	275	310	340
250	215	255	270	315	335	—
300	240	285	300	345	380	—
350	260	310	325	390	420	—
400	280	335	360	420	450	—
500	320	380	405	470	500	—
600	355	420	455	525	545	—
700	385	460	490	560	600	—
750	400	475	500	580	620	—
800	410	490	515	600	640	—
900	435	520	555	—	—	—
1,000	455	545	585	680	730	—
1,250	495	590	645	—	—	—
1,500	520	625	700	785	—	—
1,750	545	650	735	—	—	—
2,000	560	665	775	840	—	—
Col. 1	2	3	4	5	6	7

**Notes to Table L-II:**

- <sup>(1)</sup> See Table 4A of CSA C22.1-1972, "Canadian Electrical Code," for the correction factors to be applied to the values in Columns 2 to 7 for ambient temperatures over 30°C.
- <sup>(2)</sup> These capacities are only applicable under special circumstances where the use of insulated conductors having this temperature rating are acceptable to the inspection authority.

**Table L-III**

**SIZES OF CONDUCTORS, FUSE RATINGS AND CIRCUIT BREAKER SETTINGS FOR MOTOR OVERLOAD PROTECTION AND MOTOR CIRCUIT OVERCURRENT PROTECTION<sup>(1)</sup>**

Full-Load Current Rating of Motor, amp	Minimum Allowable Ampacity of Conductor	Overload Protection for Running Protection of Motors		Overcurrent Protection Maximum Allowable Rating of Fuses and Maximum Allowable Setting of Circuit Breakers of the Time-Limit Type for Motor Circuits					
		Maximum Rating of Fuses, amp	Maximum Setting of Overload Devices, amp	Single Phase All Types, Squirrel Cage and Synchronous (Full Voltage, Resistor and Reactor Starting)		Squirrel Cage and Synchronous (Autotransformer and Star-Delta Starting)		DC or Wound Rotor AC	
				Fuse, amp	Circuit Breaker, amp	Fuse, amp	Circuit Breaker, amp	Fuse, amp	Circuit Breaker, amp
1	15	2	1.25	15	15	15	15	15	15
2	15	3	2.50	15	15	15	15	15	15
3	15	4	3.75	15	15	15	15	15	15
4	15	6	5.00	15	15	15	15	15	15
5	15	8	6.25	15	15	15	15	15	15
6	15	8	7.50	20	15	15	15	15	15
7	15	10	8.75	25	15	15	15	15	15
8	15	10	10.00	25	20	20	15	15	15
9	15	12	11.25	30	20	25	15	15	15
10	15	15	12.50	30	20	25	20	15	15
11	15.00	15	13.75	30	30	30	20	20	15
12	15.00	15	15.00	40	30	30	20	20	15
13	16.25	20	16.25	40	30	35	30	20	20
14	17.50	20	17.50	45	30	35	30	25	20
15	18.75	20	18.75	45	30	40	30	25	20
16	20.00	20	20.00	50	40	40	30	25	20
17	21.25	25	21.25	60	40	45	30	30	30
18	22.50	25	22.50	60	40	45	30	30	30
19	23.75	25	23.75	60	40	50	40	30	30
20	25.00	25	25.00	60	50	50	40	30	30
22	27.5	30	27.5	60	50	60	40	35	30
24	30.0	30	30.0	80	50	60	40	40	30
26	32.5	35	32.5	80	70	70	50	40	40
28	35.0	35	35.0	90	70	70	50	45	40
30	37.5	40	37.5	90	70	70	50	45	40
32	40.0	40	40.0	100	70	70	70	50	40
34	42.5	45	42.5	110	70	70	70	60	50
36	45.0	45	45.0	110	100	80	70	60	50
38	47.5	50	47.5	125	100	80	70	60	50
40	50.0	50	50.0	125	100	80	70	60	50
42	52.5	50	52.5	125	100	90	70	70	70
44	55.0	60	55.0	125	100	90	100	70	70
46	57.5	60	57.5	150	100	100	100	70	70
48	60.0	60	60.0	150	100	100	100	80	70
50	62.5	60	62.5	150	125	100	100	80	70
52	65.0	70	65.0	175	125	110	100	80	70
54	67.5	70	67.5	175	125	110	100	90	70
56	70.0	70	70.0	175	125	125	100	90	70
58	72.5	70	72.5	175	125	125	100	90	100
60	75.0	80	75.0	200	150	125	100	90	100
Col. 1	2	3	4	5	6	7	8	9	10

**Table L-III (Cont'd)**

<b>SIZES OF CONDUCTORS, FUSE RATINGS AND CIRCUIT BREAKER SETTINGS                      FOR MOTOR OVERLOAD PROTECTION AND MOTOR CIRCUIT OVERCURRENT PROTECTION<sup>(1)</sup></b>									
Full-Load Current Rating of Motor,  amp	Minimum Allowable Ampacity of Conductor	Overload Protection for Running Protection of Motors		Overcurrent Protection Maximum Allowable Rating of Fuses and Maximum Allowable Setting of Circuit Breakers of the Time-Limit Type for Motor Circuits					
		Maximum Rating of Fuses,  amp	Maximum Setting of Overload Devices,  amp	Single Phase All Types, Squirrel Cage and Synchronous (Full Voltage, Resistor and Reactor Starting)		Squirrel Cage and Synchronous (Autotransformer and Star-Delta Starting)		DC or Wound Rotor AC	
				Fuse, amp	Circuit Breaker, amp	Fuse, amp	Circuit Breaker, amp	Fuse, amp	Circuit Breaker, amp
62	77.5	80	77.5	200	150	125	125	100	100
64	80.0	80	80.0	200	150	150	125	100	100
66	82.5	80	82.5	200	150	150	125	100	100
68	85.0	90	85.0	225	150	150	125	110	100
70	87.5	90	87.5	225	175	150	125	110	100
72	90.0	90	90.0	225	175	150	125	110	100
74	92.5	90	92.5	225	175	150	125	125	100
76	95.0	100	95.0	250	175	175	150	125	100
78	97.5	100	97.5	250	175	175	150	125	100
80	100.0	100	100.0	250	200	175	150	125	100
82	102.5	110	102.5	250	200	175	150	125	125
84	105.0	110	105.0	250	200	175	150	150	125
86	107.5	110	107.5	300	200	175	150	150	125
88	110.0	110	110.0	300	200	200	175	150	125
90	112.5	110	112.5	300	225	200	175	150	125
92	115.0	125	115.0	300	225	200	175	150	125
94	117.5	125	117.5	300	225	200	175	150	125
96	120.0	125	120.0	300	225	200	175	150	125
98	122.5	125	122.5	300	225	200	175	150	125
100	125.0	125	125.0	300	250	200	200	150	150
105	131.5	150	131.5	350	250	225	200	175	150
110	137.5	150	137.5	350	250	225	200	175	150
115	144.0	150	144.0	350	250	250	225	175	150
120	150.0	150	150.0	400	300	250	225	200	175
125	156.5	175	156.5	400	300	250	250	200	175
130	162.5	175	162.5	400	300	300	250	200	175
135	169.0	175	169.0	450	300	300	250	225	200
140	175.0	175	175.0	450	350	300	250	225	200
145	181.5	200	181.5	450	350	300	250	225	200
150	187.5	200	187.5	450	350	300	300	225	225
155	194	200	194	500	350	350	300	250	225
160	200	200	200	500	400	350	300	250	225
165	206	225	206	500	400	350	300	250	225
170	213	225	225	500	400	350	300	300	250
175	219	225	219	600	400	350	350	300	250
180	225	225	225	600	400	400	350	300	250
185	231	250	231	600	400	400	350	300	250
190	238	250	238	600	400	400	350	300	250
195	244	250	244	600	400	400	350	300	250
200	250	250	250	600	500	400	400	300	300
210	263	250	263	—	500	450	400	350	300
220	275	300	275	—	500	450	400	350	300
230	288	300	288	—	500	500	400	350	300
240	300	300	300	—	600	500	400	400	350
250	313	300	313	—	600	500	500	400	350
Col. I	2	3	4	5	6	7	8	9	10

**Note to Table L-III:**

<sup>(1)</sup> This Table is based on a room temperature of 30°C (86°F).

**Table L-IV**

<b>MAXIMUM ALLOWABLE AMPACITY OF NEUTRAL-SUPPORTED CABLE TYPES NS-1 AND NSF-2</b>		
<b>Size, AWG</b>	<b>Ampacity with 2 Insulated Aluminum Conductors</b>	<b>Ampacity with 3 Insulated Aluminum Conductors</b>
8	55	45
6	70	60
4	95	80
3	110	95
2	125	105
1	145	120
0	165	140
00	190	160
000	215	185
0000	250	215
Column 1	2	3

**Table L-V**

<b>MINIMUM SIZE OF GROUNDING CONDUCTOR</b>	
<b>Ampacity of Largest Service Conductor or Equivalent for Multiple Conductors, amp</b>	<b>Size of Copper Grounding Conductor, AWG</b>
100 or less	8
101 to 125	6
126 to 165	4
166 to 260	2
261 to 355	0
356 to 475	00
Over 475	000
Column 1	2

Table L-VI

RECOMMENDED ILLUMINATION FOR FARM OPERATIONS <sup>(1)</sup>		
Areas and Visual Tasks	Minimum Footcandles on Task at Any Time	Explanation
<b>Poultry</b>		
Breeding, production and laying houses feeding, inspection and cleaning	20	Provided by a lighting circuit separate from the circuit used to stimulate production and growth.
Charts and records	30	Localized lighting is needed where charts and records are kept.
Thermometers, thermostats and time clocks	50	Localized lighting is needed to accurately determine readings or settings.
Egg handling, packing and shipping		
General cleanliness	50	General illumination is needed to keep area clean and to detect any unsanitary conditions.
Egg quality inspection	50	Needed to examine and grade eggs. Candlering and other special grading equipment are used as separate devices for examining and grading eggs.
Loading platform, egg storage area, etc.	20	Needed for operator to move about readily and safely, and for safe operation of mechanical and loading equipment.
<b>Feed Storage</b>		
Grain, feed rations	10	Needed to read labels, scales and detect impurities and spoilage in feed.
Processing	10	Needed for operator to move about readily and safely, read labels, scales and equipment dials. Supplemental light would be needed if machine repairs are necessary.
<b>Dairy Farms</b>		
Milking operation area (milking parlor and stall barn)		
General	20	Required to determine cleanliness of cow, detect undesirable milk, handle milking equipment readily and to detect dirt and foreign objects on the floor. Should be available at cow-edge of gutter on floor.
Cow's udder	50	Supplemental, to determine cleanliness of udder, to clean udder, to examine udder.
Column 1	2	3



**Table L-VI (Cont'd)**

Areas and Visual Tasks	Minimum Footcandles on Task at Any Time	Explanation
Milk handling equipment and storage area (milk house or milk room) General	20	Required for operator to move about readily and safely and to determine floor cleanliness.
Washing area	100	Necessary to detect dirt and other impurities on the milk handling equipment. Supplementary, portable, ultra-violet fixture should be available in this area to aid in detecting milkstone on the equipment.
Bulk tank interior	100	Necessary to adequately inspect tank for cleanliness. Additional spots may be required to illuminate dipstick or scale.
Loading platform	20	Required for operator to move about readily and safely.
Feeding area (stall barn feed alley, pens and loose housing feed area)	20	Required for detecting foreign objects in grain, hay or silage.
Feed storage area, forage Haymow	3	Required for safety of the operator in moving about.
Hay inspection area	20	Required for detecting foreign objects in grain, hay or silage.
Ladders and stairs	20	
Silo	3	Luminaires should be mounted at the top of the silo near the ladder chute for ease in cleaning and lamp replacement.
Silo room	20	Required for detecting foreign objects in grain, hay or silage.
Feed storage area, grain and concentrate Grain bin	3	Required to inspect amount and condition of grain. When grain is suspected of being moldy, containing foreign objects or otherwise contaminated, samples should be inspected under higher illumination levels.
Concentrate storage area	10	Required to read labels. Higher illumination levels are required for critical inspection for impurities and spoilage.
Column 1	2	3

**Table L-VI (Cont'd)**

Areas and Visual Tasks	Minimum Footcandles on Task at Any Time	Explanation
Feed processing area	10	Required for operator to move about readily and read labels, scales and equipment dials. Additional light must be supplied by portable luminaires or daylighting if machine repairs are necessary.
Livestock housing area (community, maternity and individual calf pens, loose-housing, holding and resting areas)	7	Required to observe the condition of the animals and to detect hazards to the livestock and operator. Portable, supplementary lighting units can be used to examine or treat individual animals when required.
<b>General Areas</b>		
Machine Storage		
Garage and machine shed	5	Needed to move machinery safely. Supplemental lighting is needed for minor equipment repair.
Farm Shop		
Active storage area	10	Needed for operator to move about readily and safely.
General shop	30	Machinery repair, rough sawing.
Rough bench machine work	50	Painting, small parts, storage, ordinary sheet metal work, welding, medium bench work. May use localized lighting.
Medium bench machine work	100	Fine woodworking, drill press, metal lathe, grinder. May use localized lighting.
Miscellaneous		
Farm office	70	
Restrooms	30	
Pumphouse	20	
Exterior		
General inactive areas	0.2	Recommended to discourage prowlers and predatory animals.
General active areas (Paths, rough storage, barn lots)	1	Needed for operator to move about safely.
Service areas (fuel storage, shop, feed lots, building entrances)	3	Needed for servicing machinery.
Column 1	2	3

**Note to Table L-VI:**

(1) From Agricultural Engineers Yearbook, 1973 (see Bibliography).

**Table L-VII**  
**SPACING OF CABLE FOR FLOOR SLAB HEATING SYSTEMS, in.**

Watt Density, watts per sq ft	Watts Per Lineal Foot of Heating Cable																			
	5	6	7	8	9	10	11	12	13	14	15	16	17	18	19	20				
10	6	7 $\frac{1}{4}$	8 $\frac{3}{8}$	9 $\frac{5}{8}$	10 $\frac{3}{4}$	12	—	—	—	—	—	—	—	—	—	—				
15	4	4 $\frac{7}{8}$	5 $\frac{5}{8}$	6 $\frac{3}{8}$	7 $\frac{1}{4}$	8	8 $\frac{3}{4}$	9 $\frac{5}{8}$	10 $\frac{3}{8}$	11 $\frac{1}{4}$	12	—	—	—	—	—				
20	3	3 $\frac{5}{8}$	4 $\frac{1}{4}$	4 $\frac{3}{4}$	5 $\frac{3}{8}$	6	6 $\frac{5}{8}$	7 $\frac{1}{4}$	7 $\frac{3}{4}$	8 $\frac{3}{8}$	9	9 $\frac{5}{8}$	10 $\frac{1}{4}$	10 $\frac{3}{4}$	11 $\frac{3}{8}$	12				
25	2 $\frac{3}{8}$	2 $\frac{7}{8}$	3 $\frac{3}{8}$	3 $\frac{5}{8}$	4 $\frac{3}{8}$	4 $\frac{1}{4}$	5 $\frac{1}{4}$	5 $\frac{3}{4}$	6 $\frac{1}{8}$	6 $\frac{3}{4}$	7 $\frac{1}{4}$	7 $\frac{3}{4}$	8 $\frac{1}{8}$	8 $\frac{5}{8}$	9 $\frac{1}{8}$	9 $\frac{5}{8}$				
30	2	2 $\frac{1}{2}$	2 $\frac{3}{4}$	3 $\frac{1}{4}$	3 $\frac{3}{8}$	4	4 $\frac{1}{2}$	4 $\frac{3}{4}$	5 $\frac{1}{4}$	5 $\frac{5}{8}$	6	6 $\frac{3}{8}$	6 $\frac{3}{4}$	7 $\frac{1}{4}$	7 $\frac{1}{4}$	8				
35	1 $\frac{3}{4}$	2	2 $\frac{3}{8}$	2 $\frac{3}{4}$	3	3 $\frac{3}{8}$	3 $\frac{3}{4}$	4 $\frac{1}{8}$	4 $\frac{1}{2}$	4 $\frac{3}{4}$	5 $\frac{1}{8}$	5 $\frac{1}{2}$	5 $\frac{5}{8}$	6 $\frac{1}{4}$	6 $\frac{1}{2}$	6 $\frac{7}{8}$				
40	1 $\frac{1}{2}$	1 $\frac{3}{4}$	2	2 $\frac{1}{8}$	2 $\frac{3}{4}$	3 $\frac{1}{8}$	3 $\frac{1}{4}$	3 $\frac{5}{8}$	3 $\frac{7}{8}$	4 $\frac{1}{4}$	4 $\frac{1}{2}$	4 $\frac{3}{4}$	5 $\frac{1}{8}$	5 $\frac{3}{8}$	5 $\frac{3}{4}$	6				
Col. I	2	3	4	5	6	7	8	9	10	11	12	13	14	15	16	17				

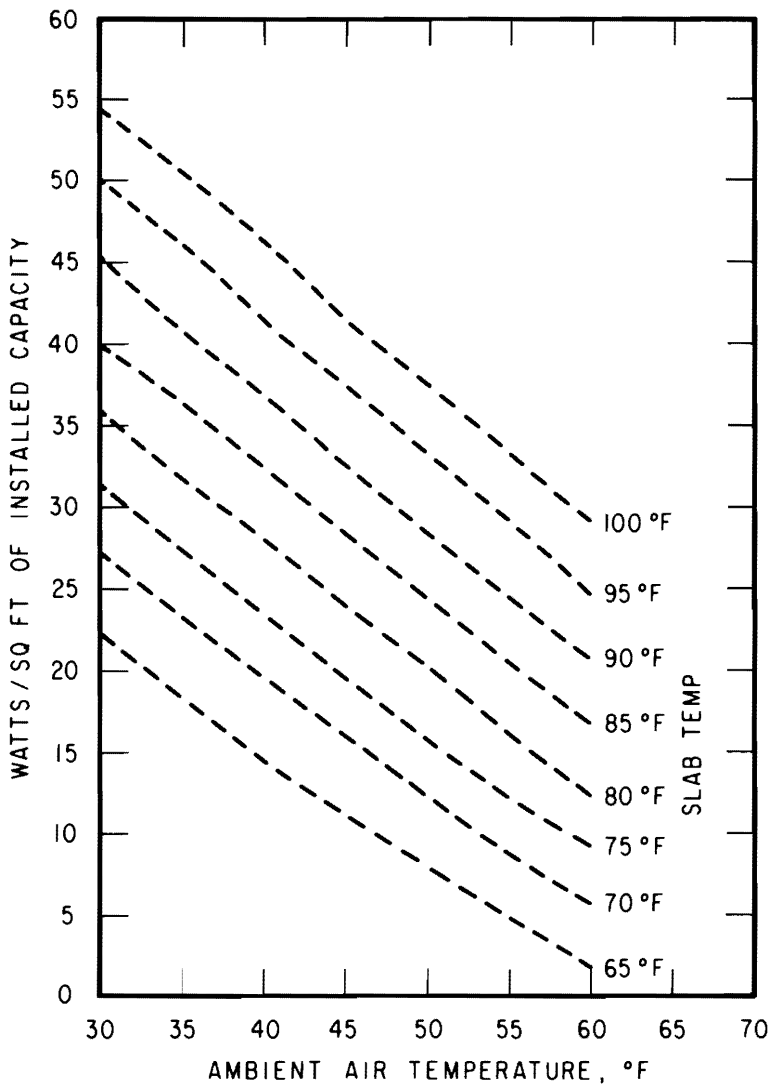

**Figure 1-L** Approximate slab temperatures obtained with various watt densities and ambient air temperatures

# **APPENDIX M**

## **CLADDING**

Table M-1

PLYWOOD WALL SHEATHING, CLADDING AND INTERIOR FINISH <sup>(1)</sup> to <sup>(5)</sup>				
Plywood Thickness, in.	Support Spacing, in.		Nail Size, in.	Nail Spacing
	Face Grain Perpendicular to Supports	Face Grain Parallel to Supports		
5/16	24	16 <sup>(5)</sup>	2	6 in. apart along panel edges, 12 in. apart on intermediate supports
3/8	32	24		
1/2	48	32		
3/8	Structural Grid System – plywood fastened to supports forming a 48 in. by 48 in. grid system (i.e. vertical studs and horizontal blocking at 48 in. o.c.)		2	6 in. apart along panel edges, 6 in. apart along intermediate supports
Column 1	2	3	4	5

**Notes to Table M-1:**

- (1) The plywood thicknesses shown are for Douglas Fir plywood. Where other species are used appropriate increases in thicknesses should be considered.
- (2) For applications of combined sheathing and cladding all edges must be supported to prevent differential deflection; e.g. battens, blocking, T & G or overlapping. Where separate cladding is used the sheathing does not require support between main members.
- (3) Special consideration must be given to the selection of plywood thickness and to the nailing schedule if the structure is designed to withstand storage pressure, in which case the Load/Span Graphs should be used.
- (4) All panels should be separated by a 1/16 in. gap.
- (5) If used as sheathing under cladding or as interior lining support spacing may be 24 in.

Table M-II

PLYWOOD ROOF SHEATHING <sup>(1),(2),(3)</sup>							
Framing	Plywood Thickness, in.						
	5/16	3/8	1/2	5/8	3/4	Remarks	
Spacing of Supports, in.	Panel edges supported by 2 x 4 headers fitted between rafters or other framing members	24	32	48	54	60	
	Panel edges supported to prevent differential deflection; H-clips, T & G plywood, spline, etc.	16	24	32	48	54	H-clip spacing shall be: 1 at midpoint for supports up to 24 in. o.c. 2 at 1/3 points for supports 25 in. to 48 in. o.c. 3 at 1/4 points for supports 49 in. to 72 in. o.c.
	Panel edges not supported	12	16	24	32	48	
Nail Length, in.	Common or spiral nails	1 1/2	1 1/2	1 3/4	2	2 1/4	Panels should be fastened to supports by nails spaced at intervals not exceeding 6 in. along all edges supported on framing nor 12 in. along intermediate supports, except that when primary supports are spaced 36 in. or greater on centres, nails should be spaced at intervals not exceeding 6 in. along all supports.
	Annularly grooved nails	1 1/2	1 1/2	1 1/2	1 3/4	2	
Staple Length, in.		7/8	1 1/8	1 1/2	2	-	Staples should be non-divergent, narrow crown, 18-gauge steel wire, galvanized or equal. Spacing should be 3 in. along all edges supported on framing members and 6 in. along intermediate supports.
Col. 1	2	3	4	5	6	7	8

**Notes to Table M-II:**

- (1) The plywood thicknesses shown are for Douglas Fir plywood. Where other species are used, appropriate increases in thicknesses should be considered.
- (2) All panels should be separated by a 1/16-in. gap.
- (3) When panel edges are unsupported, consideration must be given to the effect of differential deflection between panel edges on the roofing material. Concentrated loads such as those imposed by foot traffic are the most critical.

**Table M-III**

<b>EXTERIOR FLAKEBOARD WALL SHEATHING, CLADDING AND INTERIOR FINISH<sup>(1),(2),(3)</sup></b>						
Flakeboard Thickness, in.	Support Spacing		Nail		Staple	
	Sheathing, in.	Cladding, in.	Size, in.	Spacing	Size, in.	Spacing
5/16	24	Continuous	2	6 in. o.c. along panel edges, 12 in. o.c. along intermediate supports (6/12)	1½	4 in. o.c. along panel edges, 8 in. o.c. along intermediate supports (4/8)
¾	32	16	2	6/12	1½	4/8
½	48	24	2	6/6	2	4/4
¾	Flakeboard fastened to supports 48 in. o.c. each way		2	6/6	2	4/4
Column 1	2	3	4	5	6	7

**Notes to Table M-III:**

- (1) For combined sheathing and cladding applications, all flakeboard edges must be supported to prevent differential deflection, e.g. battens, blocking, T & G or overlapping. Where separate cladding is used, sheathing edges between main members require no support.
- (2) Special consideration must be given to flakeboard thickness and fastening if the structure is designed to withstand storage pressures, e.g. granaries.
- (3) All panels should be separated by a ½-in. gap.

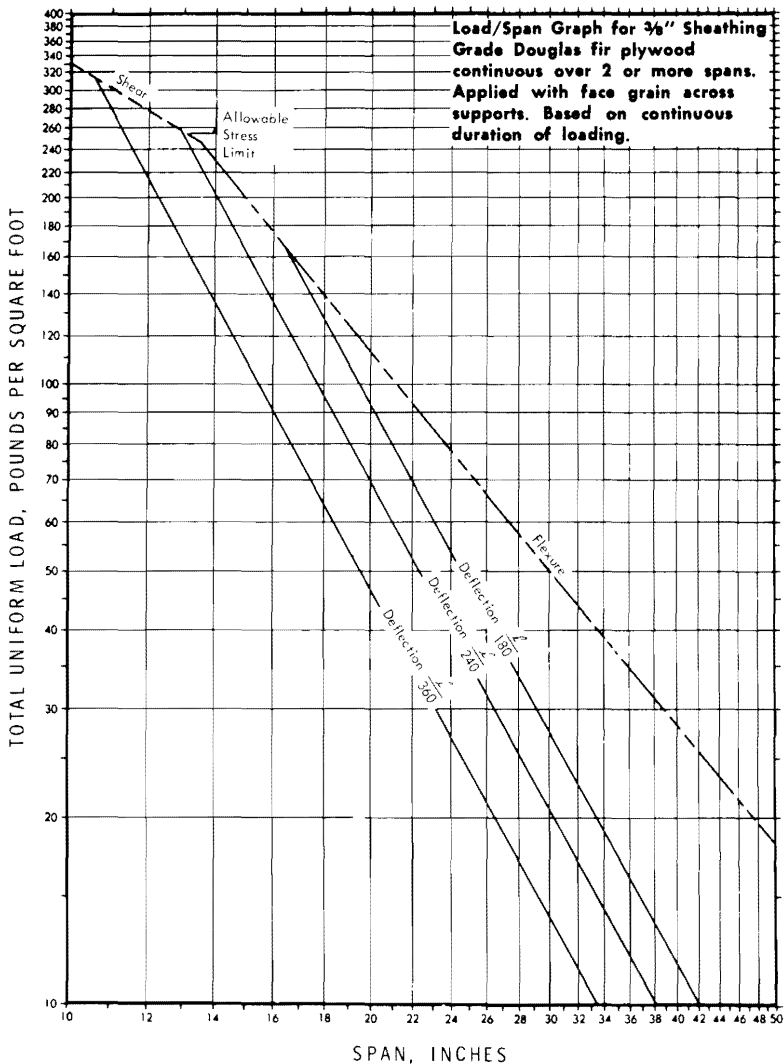

**Table M-IV**

EXTERIOR FLAKEBOARD ROOF SHEATHING <sup>(1),(2)</sup>							
	Framing	Flakeboard Thickness, in.					Remarks
		3/8	7/16	1/2	5/8	3/4	
Spacing of Supports, in.	Panel edges supported by 2 x 4 headers fitted between rafters or other framing members	24	32	40	48	54	
	Panel edges supported to prevent differential deflection using H-clips	16	24	32	40	48	H-clip spacing should be at mid-point for supports up to 24 in. o.c., at 1/3 points for supports 25 in. o.c. to 48 in. o.c.
	Panel edges unsupported	12	16	24	32	40	
Nail Length, in.	Common nails	1 1/2	1 3/4	1 3/4	2	2 1/4	Space nails 6 in. o.c. at panel edges, 12 in. o.c. into intermediate supports, except when support spacing is 36 in. o.c. or more, space nails 8 in. o.c. into all supports.
	Annularly grooved nails	1 1/2	1 1/2	1 1/2	1 3/4	2	
Staple Length, in.		1 1/8	1 1/2	1 1/2	2	-	Spacing similar to nails.
Col. 1	2	3	4	5	6	7	8

**Notes to Table M-IV:**

- (1) All panels should be separated by a 1/8-in. gap.
- (2) When panel edges are unsupported, consideration must be given to the effect of differential deflection between panel edges on the roofing material. Concentrated loads such as those imposed by foot traffic are the most critical.



**Figure 1-M** Load/span graph for 3/8-in. sheathing grade Douglas Fir plywood<sup>(1), (2), (3)</sup>

**Notes to Figure 1-M:**

- (1) The broken line marked "shear" and "flexure" indicates the load/span relationship at which the calculated shear or bending stress in the plywood reach the allowable stress as set forth in the Table of allowable unit stresses for Douglas Fir plywood in CSA O86-1970, "Code of Recommended Practice for Engineering Design in Timber," adjusted for continuous duration of loading. Solid lines indicate the load/span relationships at which the indicated deflections are reached. In many farm building applications deflection is not critical so stress limitations will govern.
- (2) See the inset on Figure 2-M for instructions on the use of the graphs.
- (3) Load/span graphs Figures 1-M to 5-M are based upon Douglas Fir plywood. Where other species are used, appropriate increases in thickness or reductions in span should be considered.

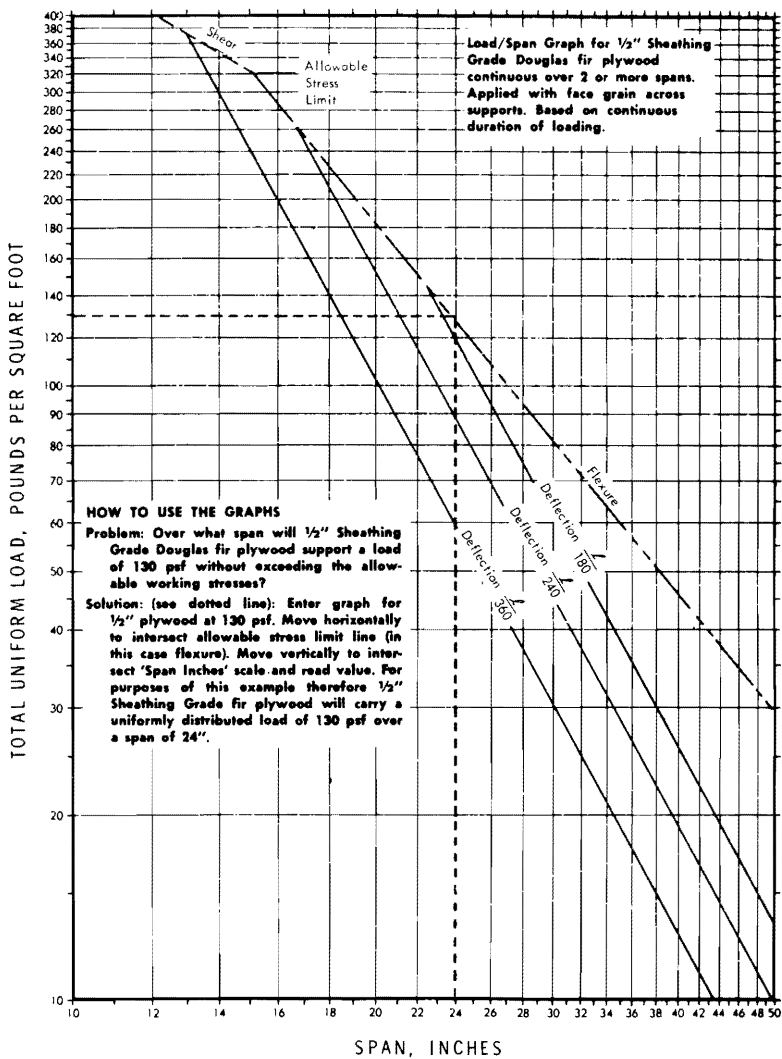

**Figure 2-M** Load/span graph for 1/2-in. sheathing grade Douglas Fir plywood

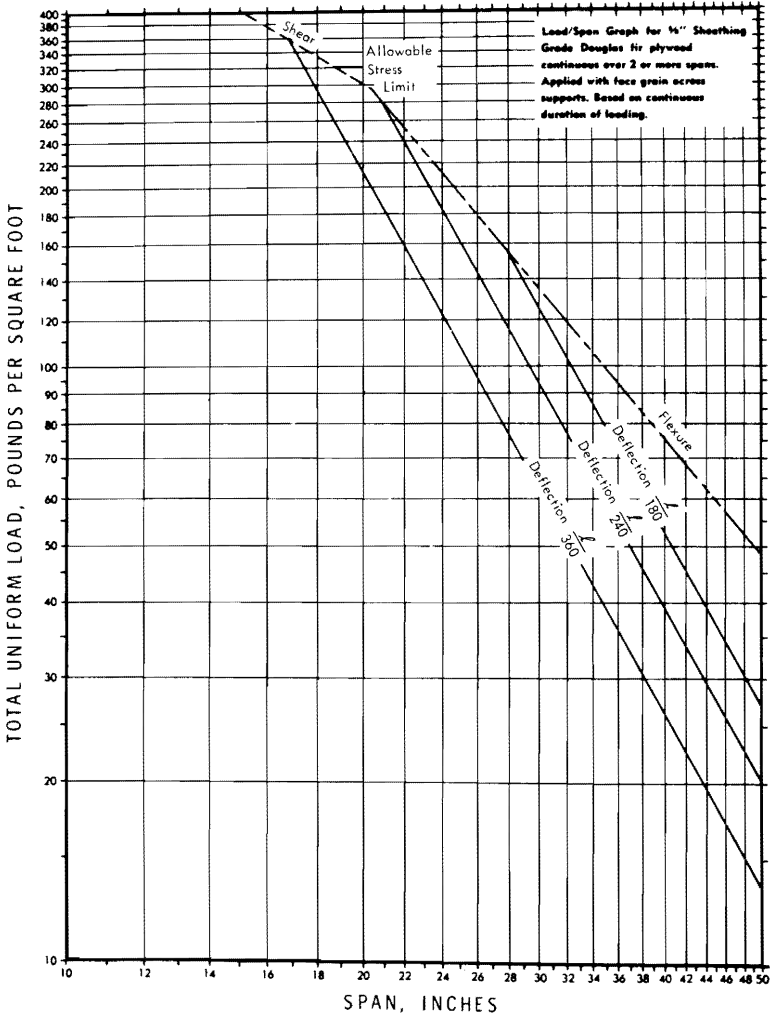

**Figure 3-M** Load/span graph for 5/8-in. sheathing grade Douglas Fir plywood

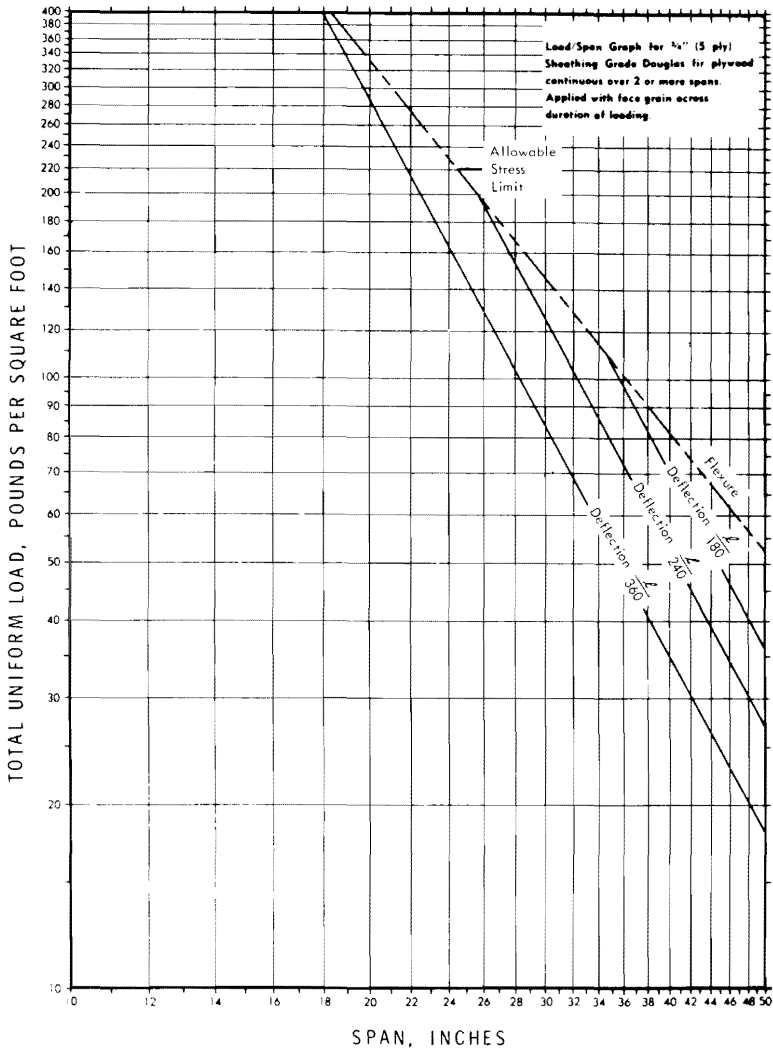

**Figure 4-M** Load/span graph for 3/4-in. sheathing grade Douglas Fir plywood

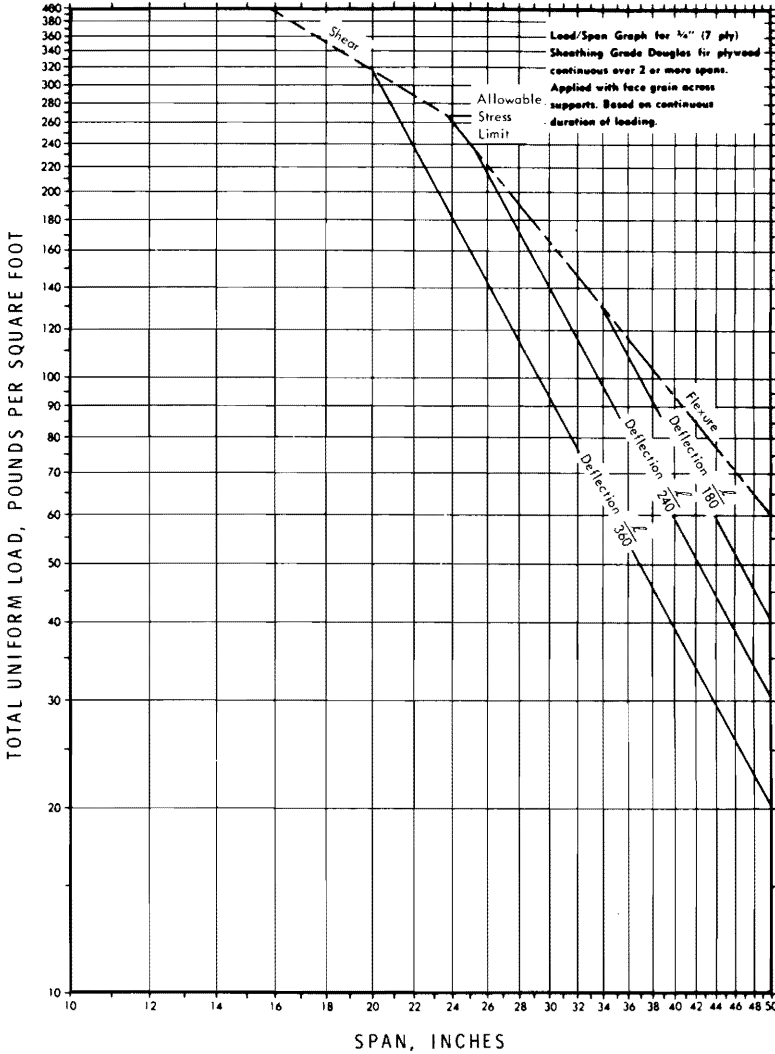

**Figure 5-M** Load/span graph for 3/4-in. (7-ply) sheathing grade Douglas Fir plywood

**APPENDIX N**  
**INSULATION VALUES OF**  
**BUILDING MATERIALS**

**Table N-I**

<b>INSULATION VALUE OF BUILDING MATERIALS</b>			
Material	Thickness, in.	R Value <sup>(1),(2)</sup>	
		At 25°F	At 75°F
<b>Insulations</b>			
Mineral wool or glass fibre, blanket, batt or loose fill types			
0.65 lb/cu ft density	1	3.7	3.3
0.75 lb/cu ft density	1	3.7	3.4
1.00 lb/cu ft density	1	4.0	3.7
1.50 lb/cu ft density	1	4.2	4.0
Cellulose fibre (cotton, wood pulp etc.)	1		3.9
Expanded mica, "vermiculite," 4 to 6 lb/cu ft	1	2.5	2.3
Dry sawdust or wood shavings, 0.8 to 1.5 lb/cu ft	1		2.2
Straw (cut, dry)	1		1.43
Corkboard	1		3.8
Polystyrene foam,			
expanded beadboard, 1.0 lb/cu ft	1	3.85	3.57
extruded polystyrene, 1.9 lb/cu ft	1	4.17	3.85
2.3 lb/cu ft	1	5.92	5.38
Polyurethane foam, 1.5 to 2.5 lb/cu ft	1	5.9	5.9
<b>Building Boards and Papers</b>			
Asbestos board	<sup>3</sup> / <sub>16</sub>		0.05
Fir plywood	<sup>3</sup> / <sub>8</sub>		0.47
Fibreboard	<sup>1</sup> / <sub>2</sub>		1.52
Phenolic bonded particleboard	<sup>3</sup> / <sub>8</sub>		0.49
Asphalt felt, 15 lb/100 sq ft			0.06
Polyethylene film vapour barrier	0.002 to 0.010		0.00
<b>Frame Construction</b>			
Wood sheathing and building paper	<sup>3</sup> / <sub>4</sub>		1.16
Same plus lap siding			2.00
Lap siding or wood shingles			0.78
Solid wood sheathing, Pine or Fir	1		1.25
<b>Roofing Materials</b>			
Built-up bitumen and felt, gravel	1		0.75
Asphalt roll roofing			0.15
Asphalt shingles			0.44
<b>Concrete and Masonry</b>			
Plain or reinforced concrete, 140 lb/cu ft	1		0.08
Lightweight concrete, 120 lb/cu ft	1		0.19
80 lb/cu ft	1		0.40
40 lb/cu ft	1		0.86
30 lb/cu ft	1		1.11
20 lb/cu ft	1		1.43
Concrete block, oval cores	8		1.11
Same plus vermiculite fill	8		1.79
Lightweight block (expanded shale, clay, slate, slag or pumice)	8		2.00
Same plus expanded mica fill	8		4.00
Column 1	2	3	4



**Table N-I (Cont'd)**

Material	Thickness, in.	R Value <sup>(1),(2)</sup>	
		At 25°F	At 75°F
<b>Surface Resistances</b> F <sub>o</sub> , for outside wall, 14 mph wind F <sub>i</sub> , for inside ceiling, non-reflective F <sub>i</sub> , for inside wall, no wind			0.17 0.61 0.68
<b>Concrete Floor to Ground</b> (at temperature difference of 20°F, air 6 in. above floor to ground)			10.0
<b>Air Space Resistances</b> vertical air space, ¾ in. and larger			1.2
<b>Windows</b> (including resistances of air space and surfaces) One vertical glass sheet Two vertical glass sheets, air space ½ in. Two vertical glass sheets, air space 1 in. or greater			0.88 1.8 1.89
Column 1	2	3	4

**Notes to Table N-I:**

- (1) Resistance values are from 1967 ASHRAE Handbook of Fundamentals, Chapter 26 and other sources.  
 $R = 1/C$ , where C = thermal conductivity, Btu/(hr) (sq ft) (°F), for thickness listed.  
 (2) R value equals resistance to heat flow for thickness listed.

**Table N-II**

TYPICAL FLOOR PERIMETER HEAT LOSS FACTORS <sup>(1)</sup>	
Description of Floor Perimeter	Perimeter Heat Loss Factor (F)
Normal concrete not insulated	0.82
Normal concrete insulated near the exterior face to 12 in. below exterior grade with rigid insulation having R = 4 (see Table N-I)	0.49
Normal concrete insulated near the exterior face to 12 in. below exterior grade with rigid insulation having R = 8 (see Table N-I)	0.25
Column 1	2

**Note to Table N-II:**

- (1) To estimate perimeter heat losses from concrete floors on grade, use the following formula:

$$H = PF (T_i - T_o)$$

where H = heat loss, Btu/hr

P = floor perimeter, ft

F = floor perimeter heat loss factor (see Table N-II)

T<sub>i</sub> = inside air temperature, °F

T<sub>o</sub> = outside air temperature, °F

**APPENDIX O**  
**DIMENSIONS OF FREE STALLS**

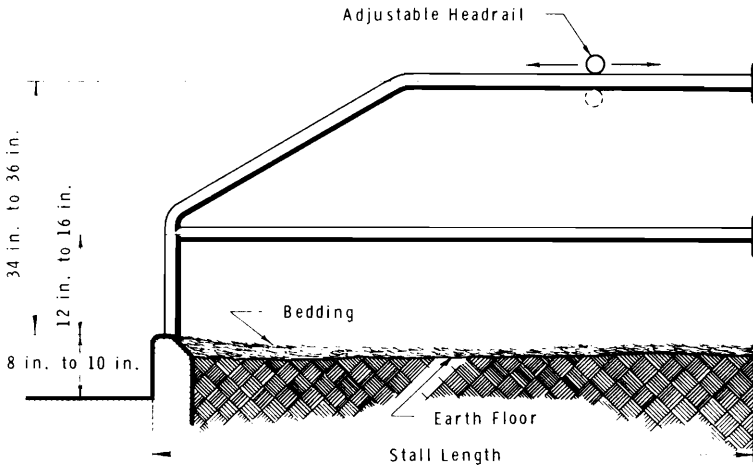

**Figure 1-O** Free stall with earth floor

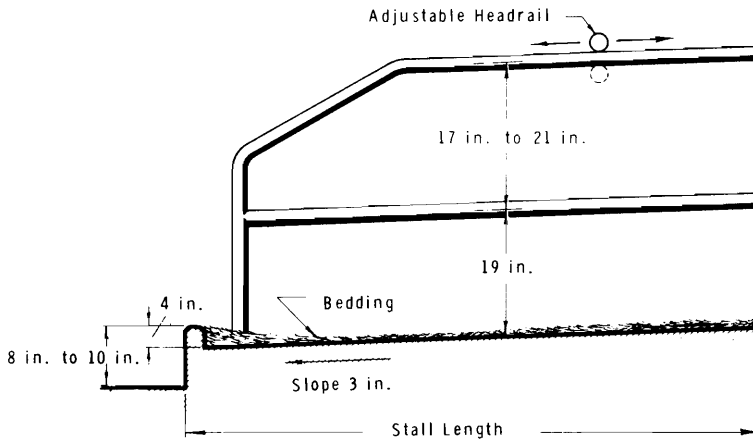

**Figure 2-O** Free stall with paved, elevated platform

# INDEX

## A

Aerobic lagoons (see Lagoons)  
Aluminum design, 24  
Anaerobic lagoons (see Lagoons),  
Anchorage, roof to unit masonry, 21  
Animal production, facilities for  
  beef cattle, 49-51, 70-71  
  chickens, 54-57, 72-74  
  dairy cattle, 45-49, 68-70  
  fur-bearing animals (mink, foxes,  
    rabbits), 58-59, 77  
  horses, 53-54, 71  
  sheep, 51, 71-72  
  swine, 52-53  
  turkeys, 57-58  
Asbestos-cement, corrugated,  
  cladding, 89-90  
Asphalt shingles, 90

## B

Backfilling, 10  
Beef cattle (see Animal production  
  facilities)  
  electrical services for  
    (see Electrical services)  
Building components, 3  
Bull pens, safety of, 33

## C

Chemical storage, 34  
Chickens (see Animal production  
  facilities)  
  electrical services for  
    (see Electrical services)  
Cladding, 24, 88-92  
  asbestos-cement, corrugated, 89-90  
  asphalt shingles, 90  
  flakeboard, 91  
  lumber siding, 90  
  metal, 88-89  
  plywood, 91  
Concrete, 22-23  
  air-entrained, 22  
  floors, 22  
  footings for columns and  
    poles, 9  
  footings for walls, 6, 9

  for foundation walls, 9-10  
  for grade beam foundations, 10  
  on-site mixing of, 22  
  pavements, 22  
  ready-mixed, 22  
  reference to NBC 1975, 22  
  silos, tower, 23  
  slabs-on-grade, 11  
Conductor  
  grounding, 31-32  
  neutral, 30  
Connections, design procedures for, 8  
Construction methods, 3  
Construction practices  
  (see also Cladding), 88-95  
  drainage, 94-95  
  general, 88  
  insulation, 93-94  
  safety measures, 4  
  vapour barriers, 92-93  
  wood preservation, 94  
Corn  
  cribs (see Product storage facilities)  
  loads imposed by (see Loads on silos)

## D

Dairy barns, 38-39  
Dairy cattle (see Animal production  
  facilities)  
  electrical services for  
    (see Electrical services)  
Dead animal disposal, 36  
Deflections, 8  
Design, 3-24  
  aluminum, 24  
  cladding, 24  
  concrete, 22-23  
  of foundations, 8-11  
  of loads, 4-7  
  procedures, 7-8  
  steel, 23  
  structural loads and procedures, 4-8  
  unit masonry, 21-22  
  wood, 11-21  
Disease control structures, 40-41  
  special treatment and  
    holding rooms in, 40-41  
Drainage for, 94-95  
  floor slope, 95

slabs-below-grade, 95  
slabs-on-grade, 95  
Drawings and specifications, 3  
Duct resistances, 66

## E

Egg holding and grading rooms, 56  
electrical services for  
(see Electrical services)  
Egg-storage and handling rooms, 74  
Electrical services for, 30-32, 67-77  
beef barns, 70-71  
branch circuits, 68  
cable heating, 32, 67  
dairy structures, 68-70  
egg storage and handling  
rooms, 74  
emergency services, 30  
exterior lighting, 77  
farm workshops and  
machinery sheds, 76  
field crop structures, 74-75  
fruit and vegetable  
structures, 75-76  
grounding, 31-32  
hog structures, 72  
horse structures, 71  
lighting, 67  
machinery sheds, 76  
maintenance shops, 76  
metering, 30  
motors, 31, 67  
poultry structures, 72-74  
protection, 31  
rabbit structure, 77  
service entrance, 30  
sheep structures, 71-72  
silos, 75  
size of service wire, 30, 67  
three-phase-power, 67  
warning systems, 68  
water supply, 76-77  
Environmental protection from, 35-38  
dead animal disposal, 36  
dead bird disposal, 81  
feedlot runoff control  
facilities, 87  
manure lagoons, 37-38, 82-85, 86-87  
manure storage, 36, 79-81  
milk centre waste, 36-37, 81-82  
oxidation ditches, 86  
Exhaust fans, 66  
Exits, requirements for, 28-29

## F

Field crop structures, 74-75  
electrical services for  
(see Electrical services)  
feed-grinding rooms, 74  
grain and feed storage, 74  
mow areas, 74  
silos, 75  
Fire, 24-29  
classification of building  
occupancies, 24  
in 2-storey barns, 25  
prevention methods in a  
compartment, 24-25  
protection, water supply, 78-79  
resistance ratings, 25-26  
resistive closures, 26  
separation, 26  
spread, 24-25, 25-26, 26-28  
stopping, 24-25  
Floors,  
concrete, 22  
sloping in, 95  
Fluid milk production, facilities for  
dairy barns, 38-39  
general, 38  
milkhouses, 39-40  
milk stands, 40  
Footings, 8-9  
concrete, 6  
for foundations, 9-10, 11  
wood, 9  
Foundations, 8-11  
concrete, 9-10  
drainage, 94-95  
footings for, 8-9  
grade beam, 10  
silo, 23  
slabs-on-grade, 11  
walls, 11  
wood, 10, 11  
Foxes (see Animal production facilities)  
Fruit, storage facilities for, 75-76  
electrical services  
(see Electrical services)  
Fur-bearing animals, accommodation for  
(see Animal production facilities)

## G

Glued structural assemblies, 21  
Good practice and performance, 43-95  
construction practices for, 88-95

- definition of, 3
- for space allowances, 45-62
- of environmental services, 62-87
- Grade beam (see Foundations)
- Granaries (see Field crop structures)
- Greenhouses, 60
  - area requirements for, 60
  - electrical services for, 75-76
  - floor loads, 5-6
- Guard rails, 32

## H

- Hazards and safety
  - fire, 24-29
  - heating, 29
  - lightning, 32
  - of electrical services, 30-32
  - refrigeration, 29
  - safety, 32-34
- Health and Sanitation (see also Environmental protection and Sanitation), 34-41
  - water sources, 34-35
- Heating and refrigerating systems, 67
- Heights, of unit masonry walls, 21
- Honey processing structures, 41
- Horses (see Animal production facilities)
  - electrical services for stables (see Electrical services)
  - floor loads (see Loads)
- Humidity, 62-66
  - limits for closed animal production buildings, 62
  - product storage, 63-65

## I

- Incinerators, 36
- Insulation, 93-94
  - for masonry units, 94
  - general, 93
  - installation of, 93-94
  - insulation values, 93, 203-204
  - materials, 93

## L

- Ladders, 33
- Lagoons, 37-38, 82-85
  - aerobic, 82
  - anaerobic, 83
  - combined anaerobic-aerobic, 83-84
  - disposal of effluent and sludge, 38

- manure, 37-38
- mechanically aerated, 37-38
- requirements for, 84-85
- Lateral support on unit masonry, 21
- Loads (Structural), 4-8
  - due to animals on slotted floors, 5
  - due to use, 5-6
  - earthquake, 7
  - materials of construction, 4-5
  - nail, 18-20
  - on footings, 6
  - on silos, 6
  - on slotted floors, 5
  - rain, 7
  - snow, 7
  - stored grain, 6
  - stored potatoes, 6
  - use, 4-5
  - vehicle storage, 5-6
  - wind, 7
- Lightning, 32
- Lintels, 21
- Lumber,
  - grading rules, 12
  - siding, 90

## M

- Machinery sheds
  - dimensions, 61-62
  - electrical services for, (see Electrical services)
  - floor loads (see Loads, for vehicle storage)
- Maintenance shops
  - dimensions, 62
  - electrical services (see Electrical services)
  - floor loads (see Loads, for vehicle storage)
- Manure disposal, 85-86
- Manure lagoon (see Lagoons)
- Manure storage, 36, 79-81
- Masonry
  - foundation, walls, 9-10
  - insulation for, 94
  - lateral support, 21
  - laying, 22
  - lintels, 21
  - mortar, 22
  - reference to NBC, 21
  - roof anchorage, 21
  - surface protection, 94
  - wall height and thickness, 21

## Materials

- insulation, 93
- cladding, 88-92
- suitability, 3
- vapour barriers, 92-93
- Milkhouses, 39-40, 70
- Milk production (see Fluid milk production facilities)
- Milk stands, 40
- Milking parlours, dimensions of, 48
- Mink, space requirements for (see Animal production requirements)
- Mortar
  - masonry, 22
  - mixes, 22
- Mow areas, electrical services for, 74
- Motors
  - isolated, 67
  - on fixed equipment, 31

## O

- Oxidation ditches, 38

## P

- Particleboard (see Flakeboard)
- Pavements, 22
- Pens
  - bull, 33
  - calf, 48
  - fox, 58
  - maternity, 48
  - mink, 58
  - rabbit, 59
- Phase converter, 67
- Piers, 10
- Plant production, facilities for, 60
  - greenhouses, 60
- Plywood, 91-92
  - finishes, 91-92
  - load/span graphs, 92
  - roofs, 92
  - standards, 91
  - walls, 91
- Poultry (see Chickens)
- Preservation of wood, 94
- Product storage facilities for, 60-61
  - corn storage in cribs, 60
  - horticultural crops, 61
  - silage, 61

## R

- Rabbits (see Animal production facilities)
- electrical services
  - (see Electrical services)
- Ready-mixed concrete (see Concrete)
- Refrigeration
  - general, 67
  - systems, 67

## S

- Safety, 32-34
  - bull pens, 33
  - chemical storage, 34
  - construction measures, 4
  - guard rails, 32
  - ladders, 33
  - liquid manure storage tanks, 34
  - overhead obstructions, 32
  - stairways, 33
  - suffocation, 34
  - water systems, 33
- Service
  - maintenance shops, 62
  - vehicle and equipment storage, 61-62
- Sheep (see Animal production facilities)
- electrical services
  - (see Electrical services)
- Silos
  - concrete, 23
  - electrical services
    - (see Electrical services)
  - horizontal, 61
  - vertical, 61
- Slabs-on-grade
  - concrete, 11
  - drainage, 95
- Slabs-below-grade, drainage, 95
- Space allowances, 45-62
  - animal production, 45-59
  - plant production, 60
  - product storage, 60-61
  - service, 61-62
- Special treatment and holding rooms, 40-41
- Specifications, 3
- Stairways, 33
- Steel, design, 23
  - reinforced footings, 9
- Storage facilities (see also Animal production facilities, and Product storage facilities)
  - corn in cribs, 60
  - feed for dairy cattle, 49
  - fuel and ammonium, 25

- horticultural, 61
- manure, 36, 79-81
- silage, 61
- vehicle and equipment, 61-62
- Structural assemblies, 20-21
- Structures (see also Animal production facilities)
  - farm workshops and machinery sheds, 76
  - field crop, 74-75
  - fruit and vegetables, 75-76
  - water supply for, 76-77
- Swine (see Animal production facilities)
  - electrical services for hog and farrowing houses (see Electrical services)

### T

- Temperature and humidity
  - controlled atmosphere storage, 65
  - limits for closed animal production buildings, 62
  - product storage, 63-65
- Thermal conductivities (see Insulation values)
- Tie stall dairy barns (see Animal production facilities)
- Turkeys (see Animal production facilities)
  - floor load for, (see Loads)
  - water consumption of (see Water supply requirements)

### U

- Unit masonry (see Masonry)

### V

- Vapour barriers, 92-93
  - installation, 92-93
  - materials, 92

- Vegetables, storage facilities for electrical services (see Electrical services)
- Vehicle and equipment, areas and dimensions, 61-62
- Vehicle storage, loads for, 5-6
- Ventilation, 66-67
  - systems, 66-67

### W

- Walls, foundation
  - backfilling, 10
  - concrete, 9-10
  - unit masonry, 9-10
  - wood frame, 10
- Wastes (see Environmental protection, and Sanitation)
- Water supply, requirements for, 77-79
  - cleaning purposes, 78
  - consumption, 77-78
  - electrical services, 76-77
  - fire protection, 78-79
  - for health and sanitation, 34-35
  - hot water heaters, 78
  - pumps, 79
- Wood
  - allowable unit stresses, 11-18
  - flakeboard, 91
  - footings, 9
  - foundation walls, 10
  - glued structural assemblies, 21
  - nailed connections, 18-20
  - plywood, 91-92
  - post and plank foundation, 11
  - preservation, 94
  - reference to NBC, 11
  - sills, 11
  - skirting, 11
  - species groups, 11
  - structural assemblies, 20-21



