

**WORLD INVESTMENT  
IN CANADA  
1985-1990**



*INVESTMENT  
CANADA*

*INVESTISSEMENT  
CANADA*

acquisition of control of its parent outside Canada. It will be obvious to readers that indirect and incidental investments are of limited value in analyzing investors' preferences for locations within Canada as in most cases the primary focus of such investments are business operations in one or more other countries.

Two further qualifications of the data and hence the analysis based on it should be noted. First, within the Investment Canada database each investment is identified with a single province - the one with the largest number of employees of the business being acquired. In many cases, there are other provinces in which the acquired business has significant operations. Second, the data for urban centres were compiled on the basis of postal codes and the definitions of urban centres were those used by Canada Post. These definitions are somewhat narrower than the definitions of Census Metropolitan Areas used by Statistics Canada.

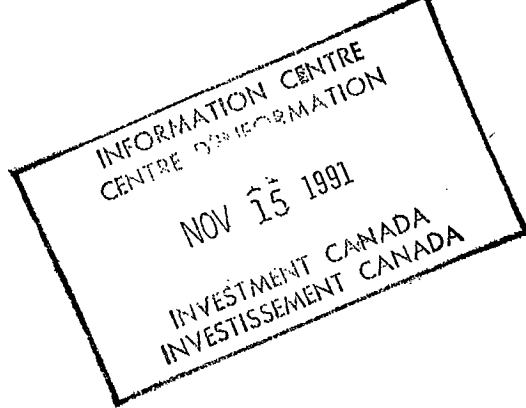

ACCESS CODE CODE D'ACCÈS	1111
COPY / ISSUE EXEMPLAIRE / NUMÉRO	

HG  
5152  
.W6

## PREFACE

The analysis in this report is based on investments filed with Investment Canada, either as notices of non-reviewable investments or as applications for review, in the period June 30, 1985 to March 31, 1990. The primary purpose of the analysis is to identify investors' locational and sectoral preferences as reflected in their investment decisions.

For completeness, the analysis is based on frequency of investments (number of transactions) and asset values. However, the frequency data are much more useful for purposes of analysis. The asset value data are of limited value in indicating investors' preferences for a number of reasons. The values used are not transaction values. They are planned investments in the first or second year of operations in the case of new business investments and the book value of the Canadian business in the case of acquisitions. The value data are also significantly skewed by a few large acquisitions. Finally, the data have not been adjusted to eliminate proposed transactions that are known not to have been implemented. This latter weakness in the database is not statistically significant with respect to the analysis based on frequency of investments but does further distort the analysis based on asset values.

Also for completeness the data include direct, indirect and incidental investments although each section contains a separate analysis based only on direct investments. Direct investments are investments for the establishment of new businesses and acquisitions of Canadian businesses, either through the acquisition of their voting interests or assets, where the transaction took place in Canada but exclude those acquisitions where the Canadian transaction was part of, or incidental to, a larger international transaction. The latter are referred to in this report as incidental investments. An indirect investment is the acquisition of control of a Canadian business through

## TABLE OF CONTENTS - WORLD INVESTMENT TO CANADA

<u>File #</u>	<u>Region: Summary</u>	<u>Investment Type</u>	<u>Measurement</u>
1.00	Executive Summary - Canada: An Overview		
1.10	Canada: Graphical Summary:		
1.20	Comparison of Provinces	All	Assets & Frequ.
1.21		Direct	Assets & Frequ.
1.30	Types of Investment	All & Direct	Assets
1.31		All & Direct	Frequencies
1.40	Industry Sectors	All	Assets
1.41		All	Frequencies
1.42		Direct	Assets
1.43		Direct	Frequencies
1.50	Canada: Spreadsheet Summary		
2.00	Atlantic Provinces: An Overview		
2.10	Atlantic Provinces: Graphical Summary:		
2.20	Overview	All	Assets
2.21		All	Frequencies
2.22		Direct	Assets
2.23		Direct	Frequencies
2.30	Comparison of Provinces	All	Assets & Frequ.
2.31		Direct	Assets & Frequ.
2.40	Types of Investment	All	Assets & Frequ.
2.41		Direct	Assets & Frequ.
2.50	Industry Sectors	All	Assets
2.51		All	Frequencies
2.52		Direct	Assets
2.53		Direct	Frequencies
2.60	Atlantic Provinces: Spreadsheet Summary		
3.00	Quebec: An Overview		
3.10	Quebec: Graphical Summary:		
3.20	Overview	All	Assets
3.21		All	Frequencies
3.22		Direct	Assets
3.23		Direct	Frequencies
3.30	Types of Investment	All & Direct	Assets
3.31		All & Direct	Frequencies
3.40	Industry Sectors	All	Assets
3.41		All	Frequencies
3.42		Direct	Assets
3.43		Direct	Frequencies
3.50	Quebec: Spreadsheet Summary		

## TABLE OF CONTENTS - WORLD INVESTMENT TO CANADA

4.00	Ontario: An Overview		
4.10	Ontario: Graphical Summary:		
4.20	Overview	All	Assets
4.21		All	Frequencies
4.22		Direct	Assets
4.23		Direct	Frequencies
4.30	Types of Investment	All & Direct	Assets
4.31		All & Direct	Frequencies
4.40	Industry Sectors	All	Assets
4.41		All	Frequencies
4.42		Direct	Assets
4.43		Direct	Frequencies
4.50	Ontario: Spreadsheet Summary		
5.00	Prairie Provinces: An Overview:		
5.1	Prairie Provinces: Graphical Summary:		
5.10	Overview	All	Assets
5.11		All	Frequencies
5.12		Direct	Assets
5.13		Direct	Frequencies
5.14	Comparison of Provinces	All	Assets & Frequ
5.15		Direct	Assets & Frequ
5.16	Types of Investment	All & Direct	Assets
5.17		All & Direct	Frequencies
5.18	Industry Sectors	All	Assets
5.19		All	Frequencies
5.20		Direct	Assets
5.21		Direct	Frequencies
5.30	Prairie Provinces: Spreadsheet Summary		
5.4	Manitoba: Graphical Summary:		
5.40	Overview	All	Assets
5.41		All	Frequencies
5.42		Direct	Assets
5.43		Direct	Frequencies
5.44	Types of Investment	All & Direct	Assets
5.45		All & Direct	Frequencies
5.46	Industry Sectors	All	Assets
5.47		All	Frequencies
5.48		Direct	Assets
5.49		Direct	Frequencies
5.50	Manitoba: Spreadsheet Summary:		

## TABLE OF CONTENTS - WORLD INVESTMENT IN CANADA

5.6	Saskatchewan: Graphical Summary:		
5.60	Overview	All	Assets
5.61		All	Frequencies
5.62		Direct	Assets
5.63		Direct	Frequencies
5.64	Types of Investment	All	Assets & Frequ
5.65		Direct	Assets & Frequ.
5.66	Industry Sectors	All	Assets
5.67		All	Frequencies
5.68		Direct	Assets
5.69		Direct	Frequencies
5.70	Saskatchewan: Spreadsheet Summary		
5.8	Alberta: Graphical Summary:		
5.80	Overview	All	Assets
5.81		All	Frequencies
5.82		Direct	Assets
5.83		Direct	Frequencies
5.84	Types of Investment	All & Direct	Assets
5.85		All & Direct	Frequencies
5.86	Industry Sectors	All	Assets
5.87		All	Frequencies
5.88		Direct	Assets
5.89		Direct	Frequencies
5.90	Alberta: Spreadsheet Summary		
6.00	British Columbia: An Overview		
6.1	British Columbia: Graphical Summary:		
6.10	Overview	All	Assets
6.11		All	Frequencies
6.12		Direct	Assets
6.13		Direct	Frequencies
6.20	Types of Investment	All & Direct	Assets
		All & Direct	Frequencies
6.30	Industry Sectors	All	Assets
6.31		All	Frequencies
6.32		Direct	Assets
6.33		Direct	Frequencies
6.50	British Columbia: Spreadsheet Summary		

## TABLE OF CONTENTS - WORLD INVESTMENT IN CANADA

7.00	Territories: An Overview		
7.1	Territories: Graphical Summary		
7.10	Overview	All	Assets
7.11		All	Frequencies
7.12		Direct	Assets
7.13		Direct	Frequencies
7.20	Comparison of Territories	All	Assets & Frequ.
7.21		Direct	Assets & Frequ.
7.30	Types of Investment	All & Direct	Assets
7.31		All & Direct	Frequencies
8.00	Urban Centres: An Overview		
8.1	Urban Centres: Graphical Summary		
8.10	Overview	All	Assets
8.11		All	Frequencies
8.12		Direct	Assets
8.13		Direct	Frequencies
8.2	Montreal: Graphical Summary:		
8.20	Comparison with Quebec	All	Assets & Frequ.
8.21		Direct	Assets & Frequ.
8.22	Types of Investment	All	Assets & Frequ.
8.23		Direct	Assets & Frequ.
8.24	Industry Sectors	All	Assets
8.25		All	Frequencies
8.26		Direct	Assets
8.27		Direct	Frequencies
8.30	Montreal: Spreadsheet Summary		
8.4	Toronto: Graphical Summary:		
8.40	Comparison with Ontario	All	Assets & Frequ.
8.41		Direct	Assets & Frequ.
8.42	Types of Investment	All	Assets & Frequ.
8.43		Direct	Assets & Frequ.
8.44	Industry Sectors	All	Assets
8.45		All	Frequencies
8.46		Direct	Assets
8.47		Direct	Frequencies
8.50	Toronto: Spreadsheet Summary		

## TABLE OF CONTENTS - WORLD INVESTMENT IN CANADA

8.6	Calgary: Graphical Summary:		
8.60	Comparison with Alberta	All	Assets & Frequ.
8.61		Direct	Assets & Frequ.
8.62	Types of Investment	All	Assets & Frequ.
8.63		Direct	Assets & Frequ.
8.64	Industry Sectors	All	Assets
8.65		All	Frequencies
8.66		Direct	Assets
8.67		Direct	Frequencies
8.70	Calgary: Spreadsheet		
8.8	Vancouver: Graphical Summary:		
8.80	Comparison with B.C.	All	Assets & Frequ.
8.81		Direct	Assets & Frequ.
8.82	Types of Investment	All	Assets & Frequ.
8.83		Direct	Assets & Frequ.
8.84	Industry Sectors	All	Assets
8.85		All	Frequencies
8.86		Direct	Assets
8.87		Direct	Frequencies
8.90	Vancouver: Spreadsheet		



## WORLD - CANADA - AN OVERVIEW

REGION:	TYPE OF INVESTMENT:	TOTAL ASSET VALUE (000'S):	TOTAL FREQUENCY:
North - West & Yukon Territories	All	395,517	12
	Direct	383,801	10
MAJOR CITIES:			
Toronto	All	12,572,230	727
	Direct	8,485,903	598
Montreal	All	5,122,337	255
	Direct	3,764,913	230
Calgary	All	3,074,559	158
	Direct	1,886,269	143
Vancouver	All	3,658,499	266
	Direct	3,224,758	256

## WORLD - CANADA - AN OVERVIEW

REGION:	TYPE OF INVESTMENT:	TOTAL ASSET VALUE (000'S):	TOTAL FREQUENCY:
Canada	All	87,768,032	4701
	Direct	62,758,991	3926
Newfoundland	All	175,189	34
	Direct	173,434	33
Nova Scotia	All	502,328	64
	Direct	451,242	60
New Brunswick	Direct	142,439	18
Prince Edward	All	219,208	5
	Direct	212,427	4
Quebec	All	15,915,700	629
	Direct	12,514,251	552
Ontario	All	46,083,111	2773
	Direct	29,368,532	2176
Manitoba	All	899,418	77
	Direct	851,223	71
Saskatchewan	All	1,379,715	44
	Direct	1,167,881	40
Alberta	All	14,864,224	484
	Direct	11,406,076	437
British Columbia	All	7,190,360	557
	Direct	6,087,696	523

# WORLD - CANADA - AN OVERVIEW

## COMPARISON BETWEEN PROVINCES

Ontario dominates with 53% of the asset value and 59% of the frequency of all foreign investment. Quebec, Alberta and British Columbia are also significant with 18%, 17% and 8% respectively, of the total asset value of investment transactions. Relatively large investments in the petroleum and natural gas industry account for 64% of the asset value of investment in Alberta. The asset value of investment to all the other provinces and territories in Canada accounts for less than 5% of the total.

After Ontario, Quebec, and British Columbia are the most frequent destinations with 13%, 12%, and 10% respectively of the total investment transactions. Only 5% of the total transactions are targeted to all the other provinces and territories.

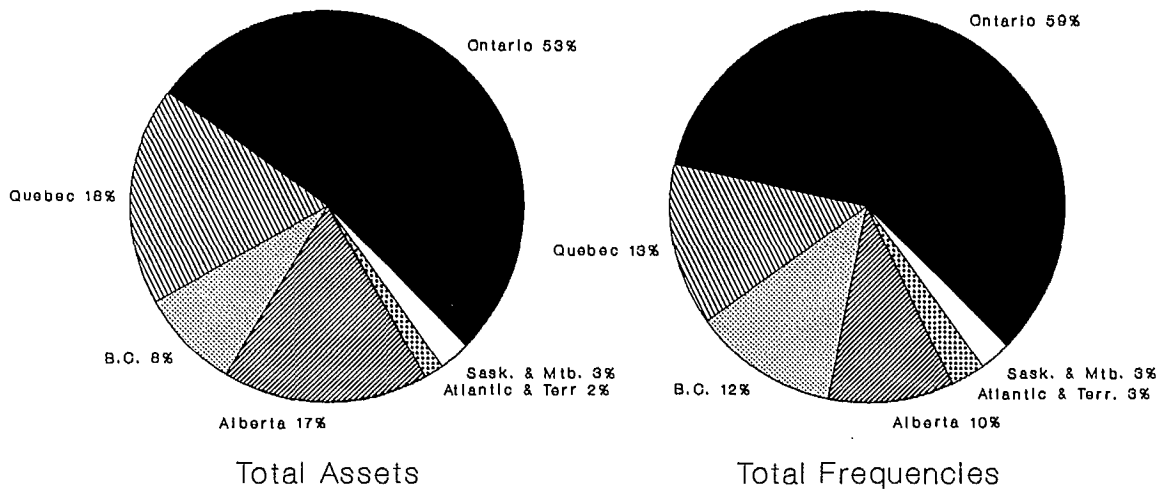

includes direct, indirect and incidental investment

# WORLD - CANADA - AN OVERVIEW

## TYPES OF INVESTMENT

72% of the asset value and 84% of the frequency of investment is direct. New business accounts for 9% of the asset value and 36% of the frequency of direct investment.

### TOTAL ASSETS

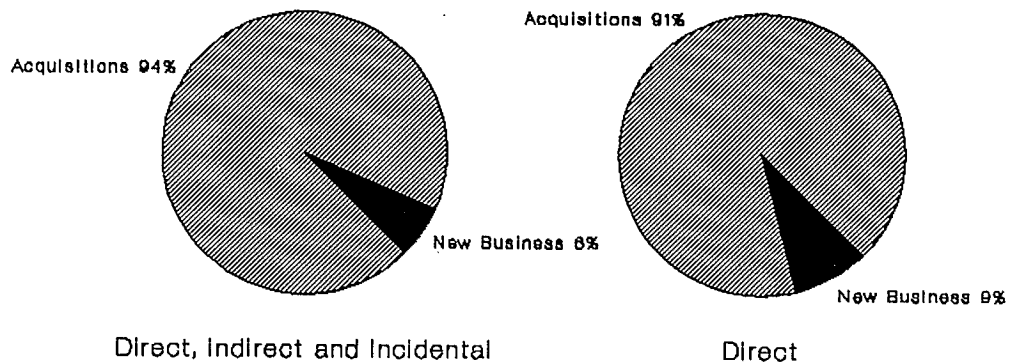

### TOTAL FREQUENCIES

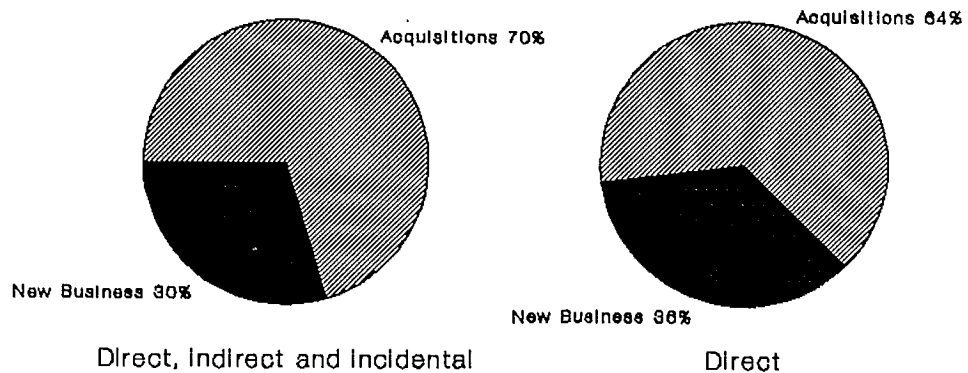

# WORLD - CANADA - AN OVERVIEW

## INDUSTRY SECTORS

Manufacturing is the most popular industry with 46% of the asset value and 33% of the frequency of investment. Petroleum and natural gas industries attract a high 16% of the total asset value, and a lower 5% of the frequency of investment. Mining (7%), wholesale trade (7%), finance and insurance (5%) also attract significant portions of the asset value of investment.

23% of the total frequency of investment is made in wholesale trade. A relatively large portion, 42%, of the transactions in this industry involved new businesses. Business services (10%), real estate and insurance agents (5%), and other services (5%) also attracted large portions of investment transactions.

## TOTAL ASSETS

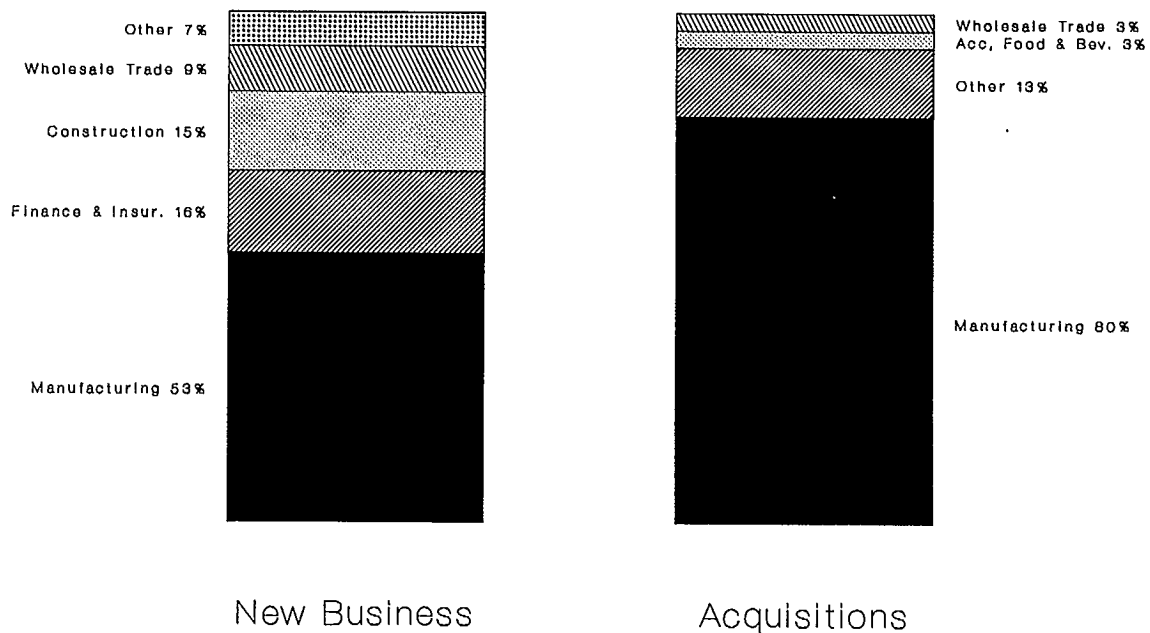

includes direct, indirect and incidental investment

# WORLD - CANADA - AN OVERVIEW

## INDUSTRY SECTORS

### TOTAL FREQUENCIES

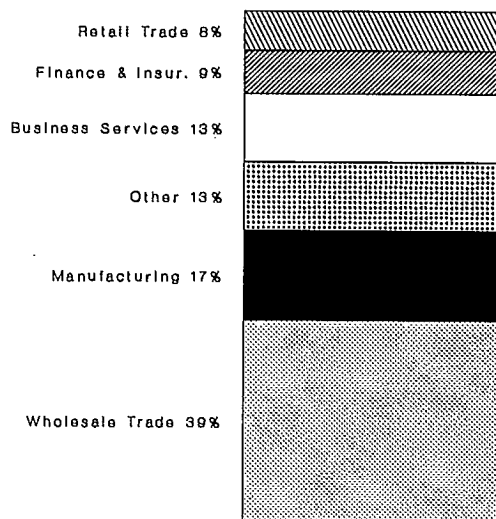

New Business

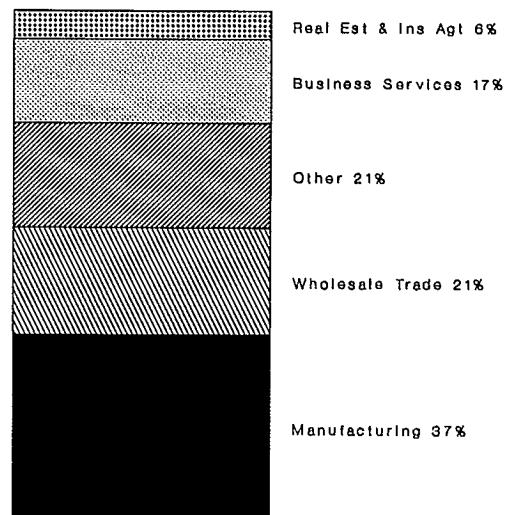

Acquisitions

includes direct, indirect and incidental investment

# WORLD - CANADA 1985-1990 COMPARISON OF PROVINCES

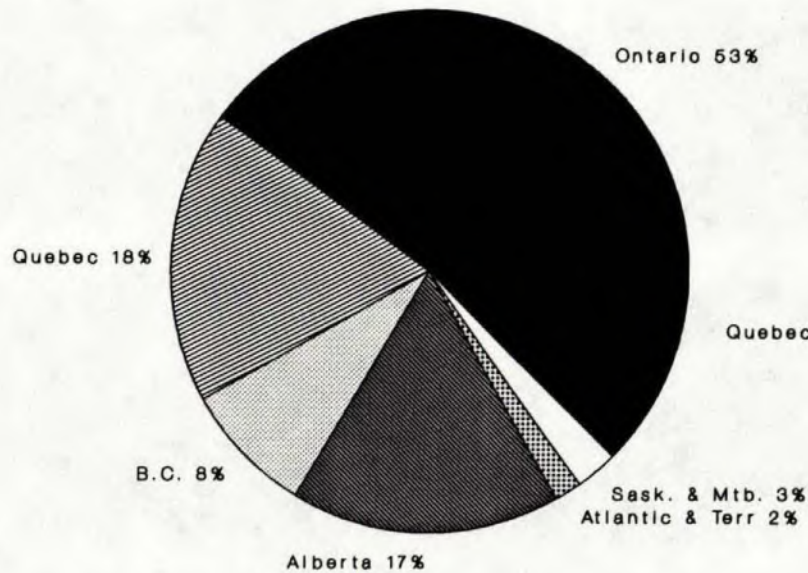

Total Assets

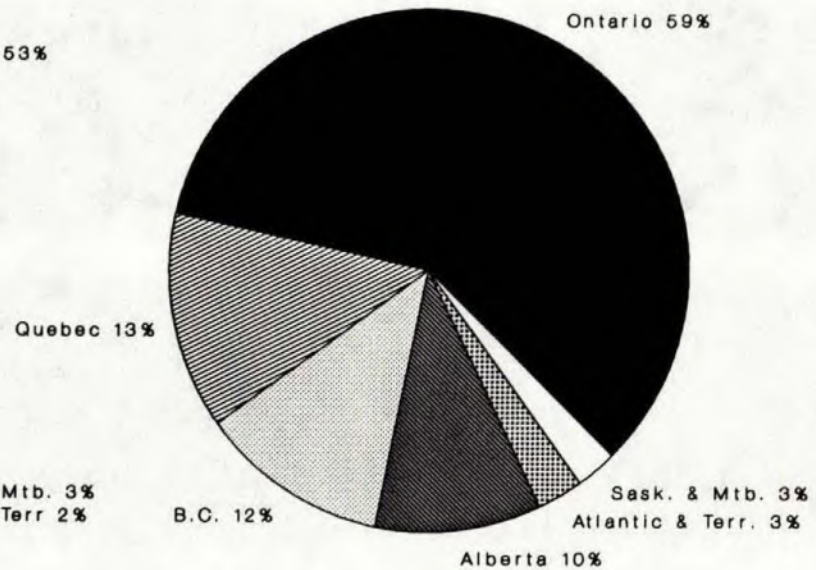

Total Frequencies

includes direct, indirect and incidental investment

# WORLD - CANADA 1985-1990 COMPARISON OF PROVINCES

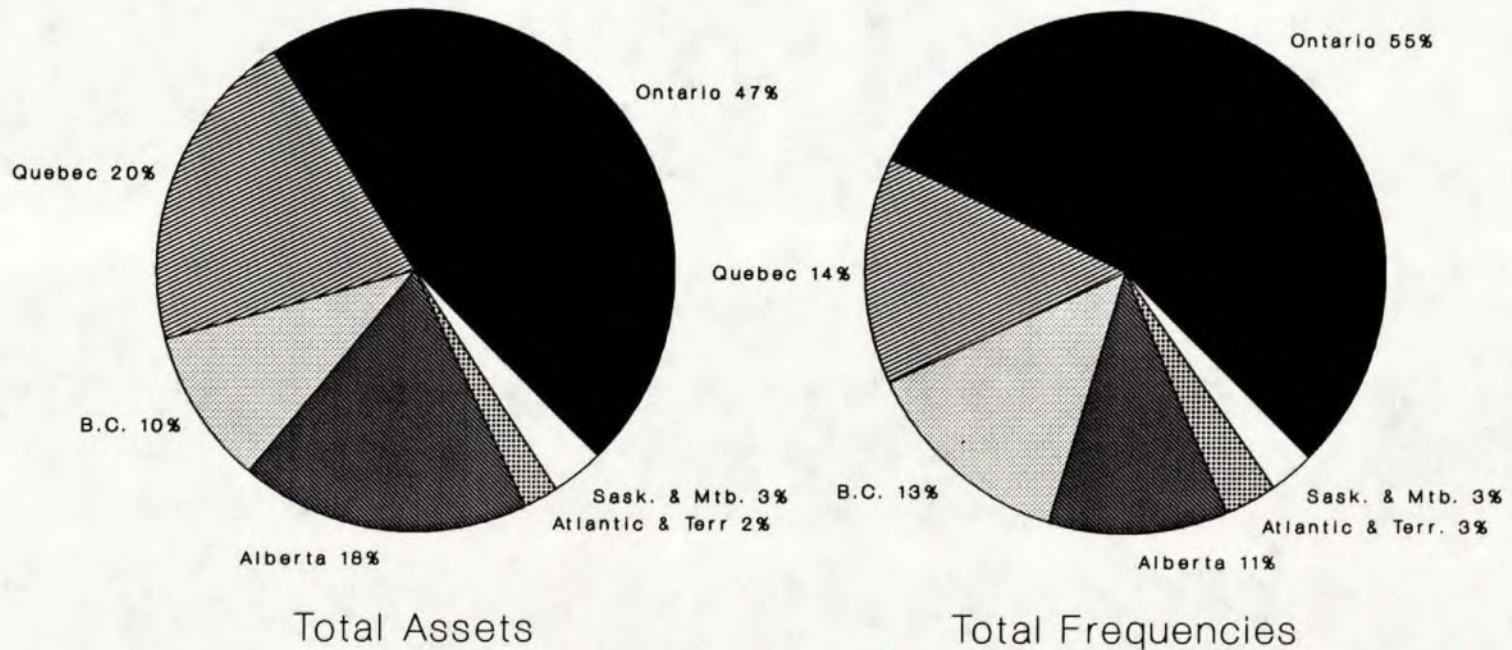

direct investment only



# WORLD - CANADA 1985-1990

## TYPES OF INVESTMENT

### TOTAL ASSETS

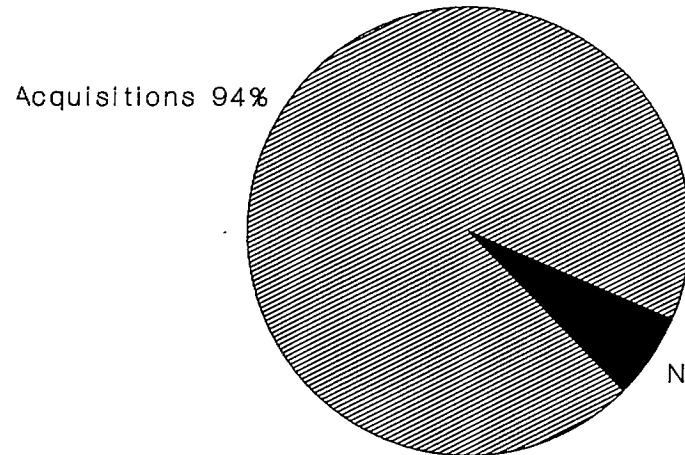

Direct, Indirect and Incidental

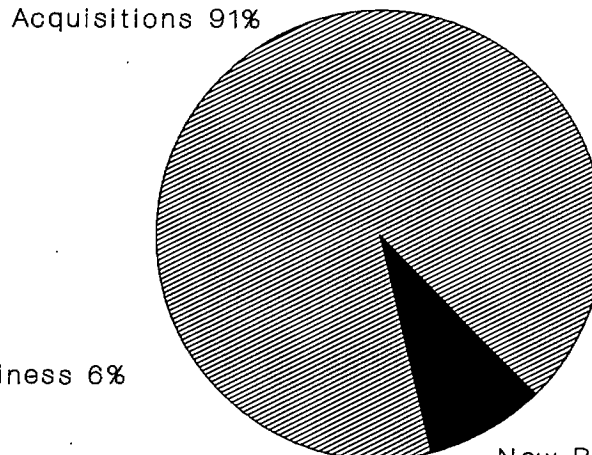

Direct

**72% of the asset value of investment was direct**

# WORLD - CANADA 1985-1990

## TYPES OF INVESTMENT

### TOTAL FREQUENCIES

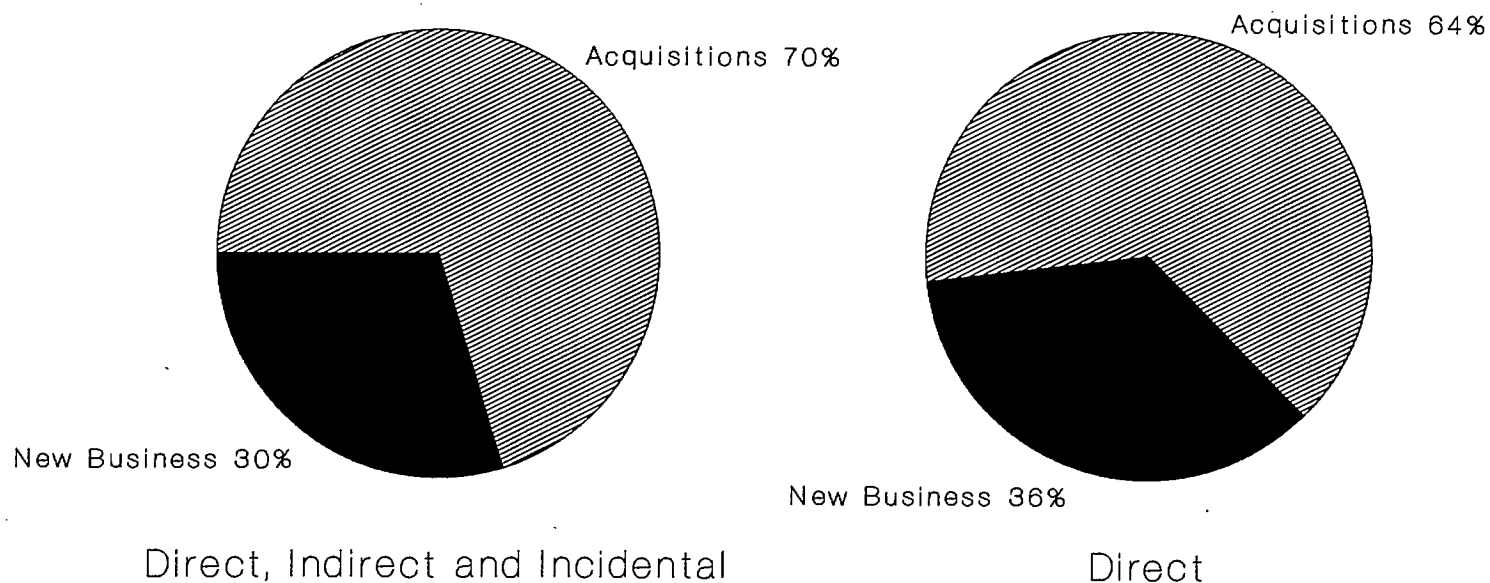

**84% of the total number of investment transactions were direct**

# WORLD - CANADA 1985-1990

## INDUSTRY SECTORS

### TOTAL ASSETS

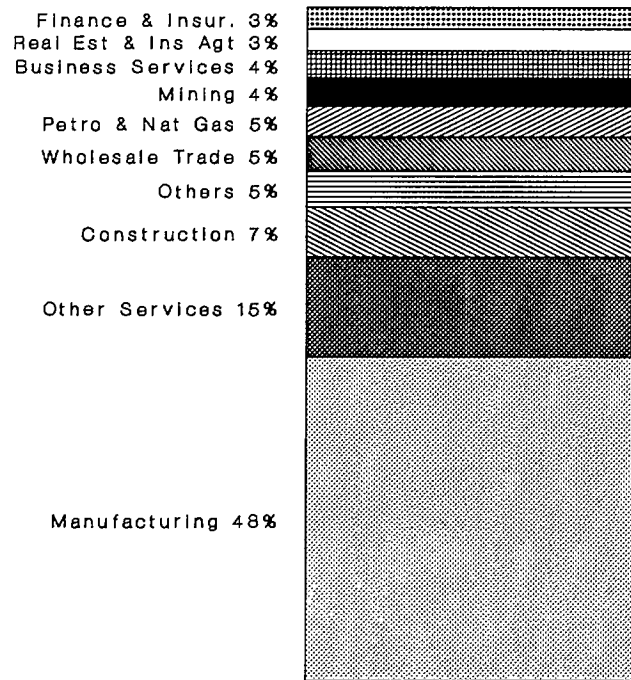

New Business

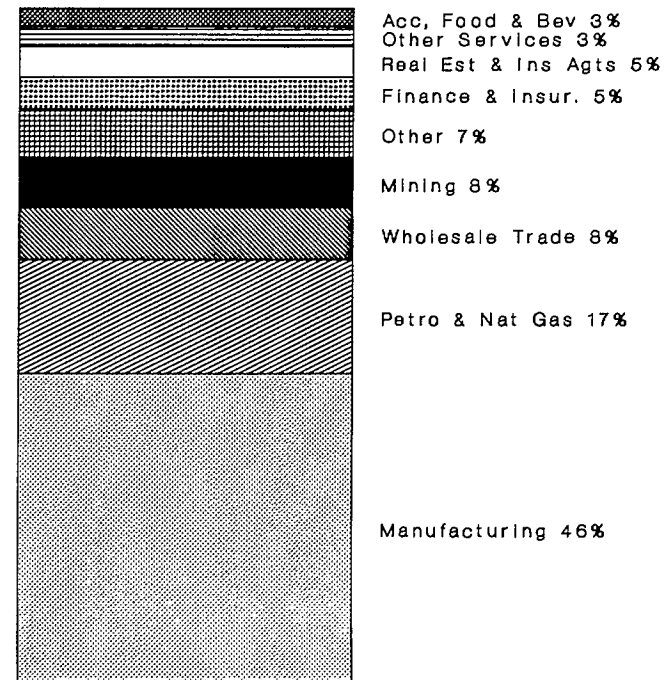

Acquisitions

**includes direct, indirect and incidental investment**

# WORLD - CANADA 1985-1990

## INDUSTRY SECTORS

### TOTAL FREQUENCIES

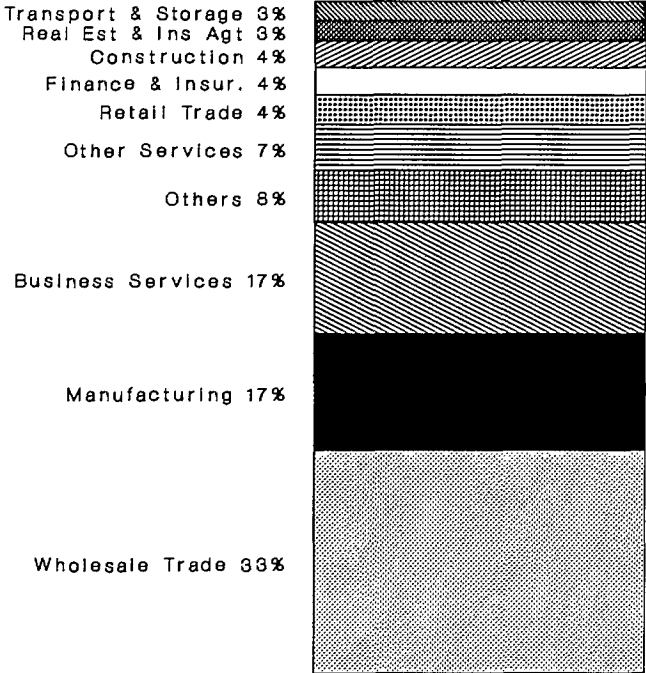

New Business

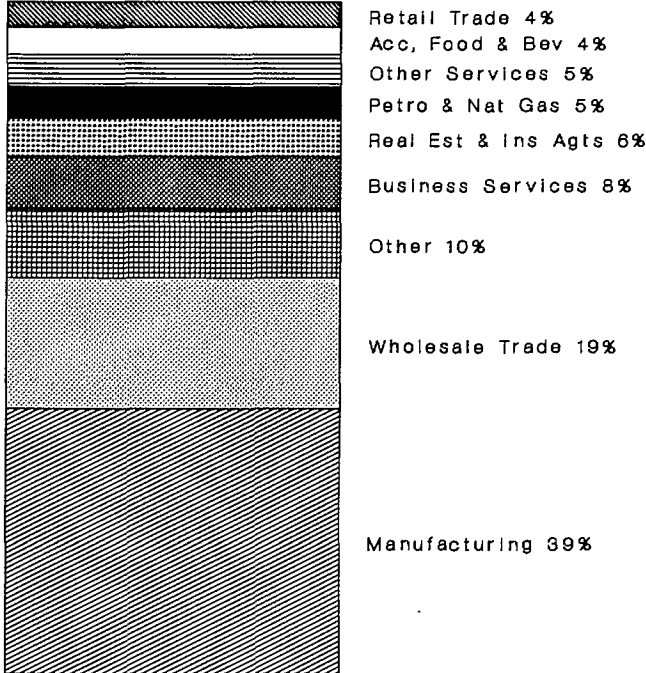

Acquisitions

**includes direct, indirect and incidental investment**

# WORLD - CANADA 1985-1990

## INDUSTRY SECTORS

### TOTAL ASSETS

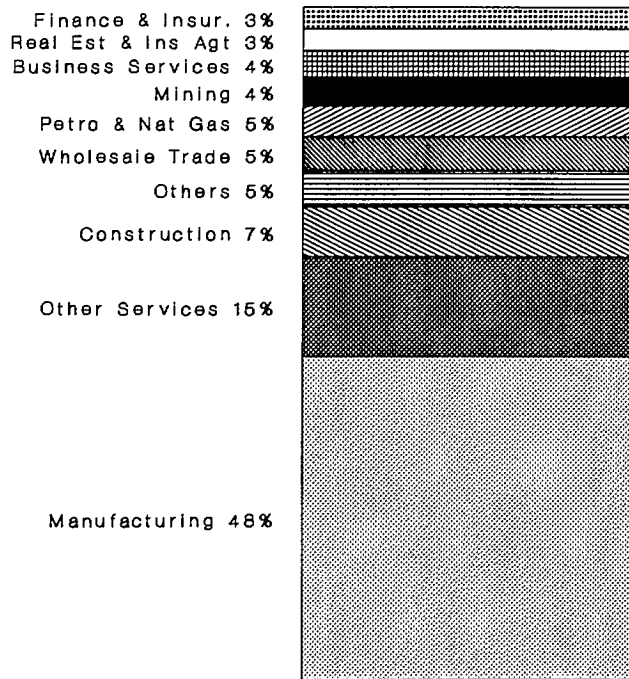

New Business

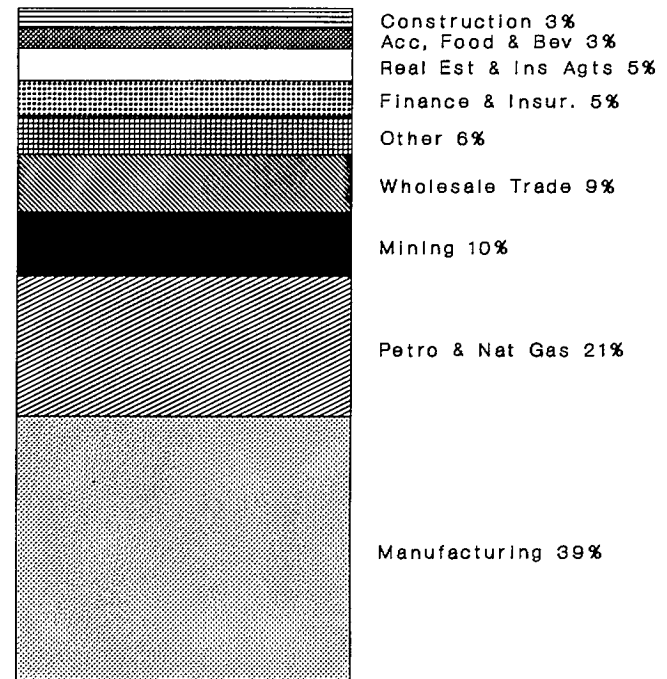

Acquisitions

**direct investment only**

# WORLD - CANADA 1985-1990

## INDUSTRY SECTORS

### TOTAL FREQUENCIES

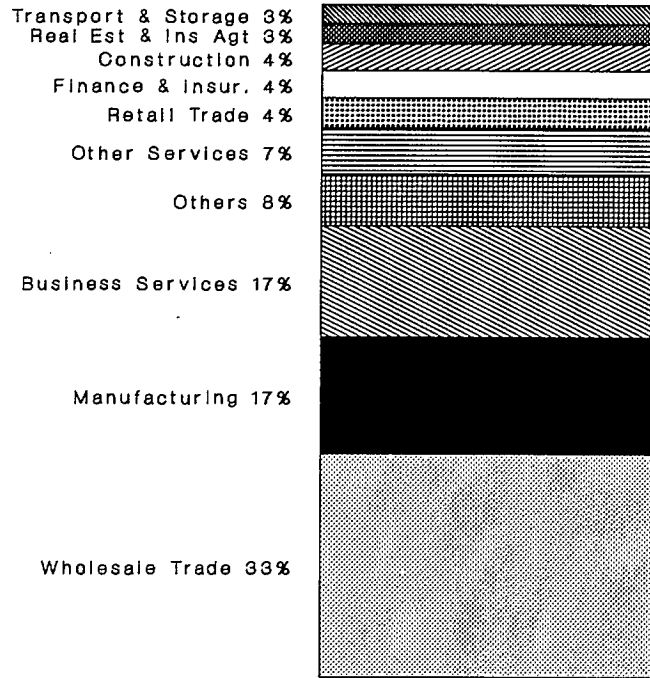

New Business

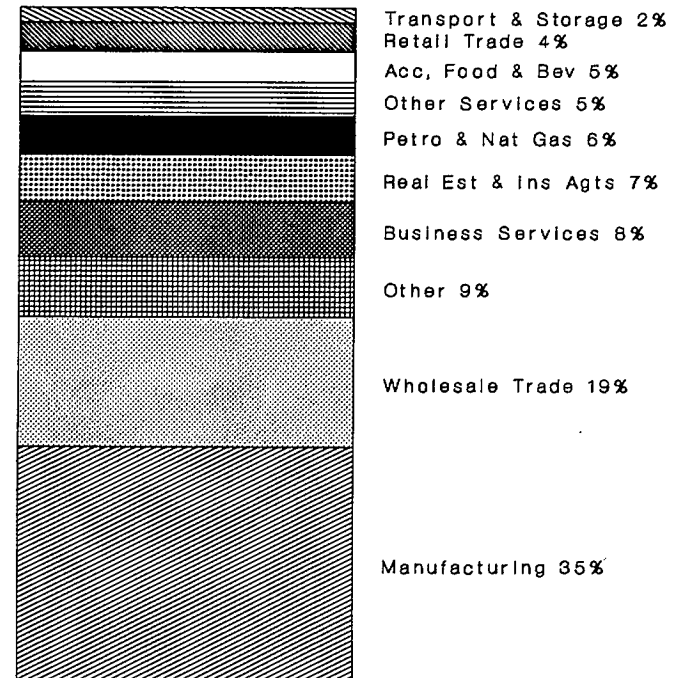

Acquisitions

**direct investment only**

# **WORLD - ATLANTIC PROVINCES - AN OVERVIEW**

## **OVERVIEW**

A very small portion of foreign investment, 1% of the total asset value and less than 3% of the total number of transactions, is made in the Atlantic provinces.

## **COMPARISON BETWEEN PROVINCES**

Nova Scotia is the primary destination of the Atlantic provinces with 48% of the asset value and 53% of the frequency of total investment. Prince Edward Island (21%), Newfoundland (17%), and New Brunswick (14%) follow in terms of the asset value of investment. One new business in the P.E.I. construction industry accounts for 91% of the asset value of investment made there. According to the frequency of investment, Newfoundland (28%), New Brunswick (14%), and P.E.I. (4%) follow Nova Scotia.

## **TYPES OF INVESTMENT**

94% of the asset value and 97% of the frequency of investment is direct. New business accounts for 52% of the asset value and 28% of the frequency of direct investment.

## **INDUSTRY SECTORS**

Mining (21%), construction (21%), petroleum and natural gas (18%), and manufacturing (16%) drew the greatest asset value of investment. Manufacturing (24%) and wholesale trade (22%) were the most frequent sectors targeted by foreign investors.

# WORLD - ATLANTIC CANADA 1985-1990 COMPARISON BETWEEN PROVINCES

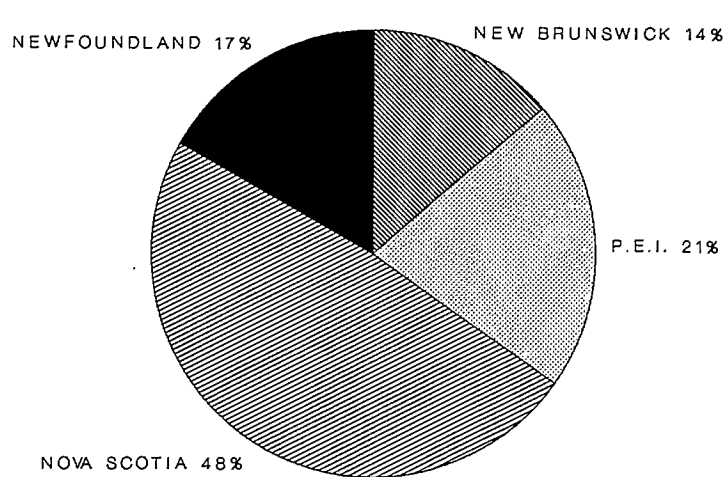

Total Asset Value

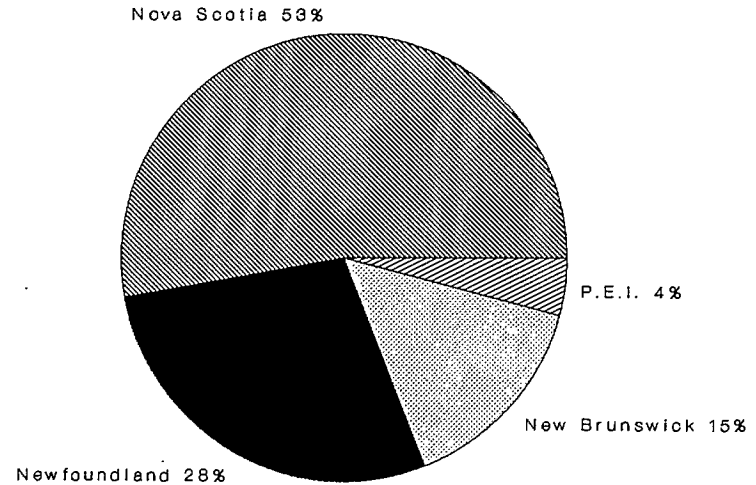

Total Frequency

includes direct, indirect and incidental investment



# WORLD - ATLANTIC CANADA 1985-1990 OVERVIEW TOTAL ASSETS

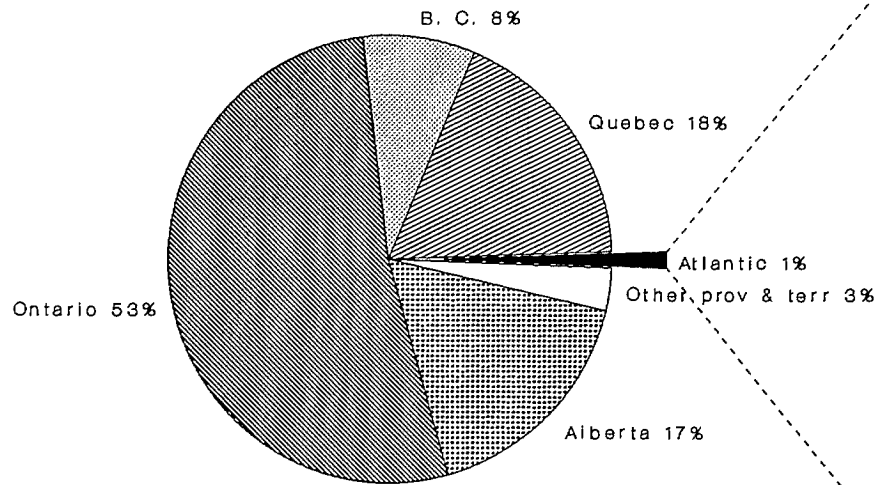

Comparison with Rest of Canada

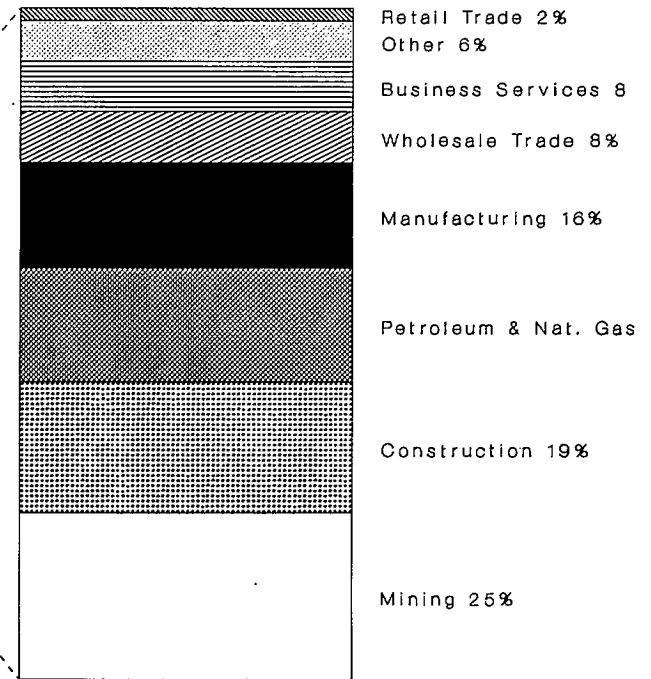

Industrial Sectors

includes direct, indirect and incidental investment

# WORLD - ATLANTIC CANADA 1985-1990

## OVERVIEW

### TOTAL ASSETS

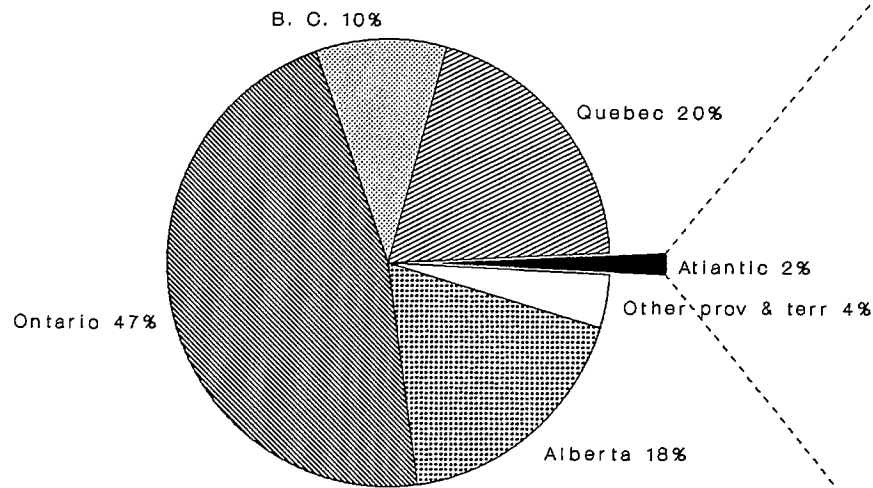

Comparison with Rest of Canada

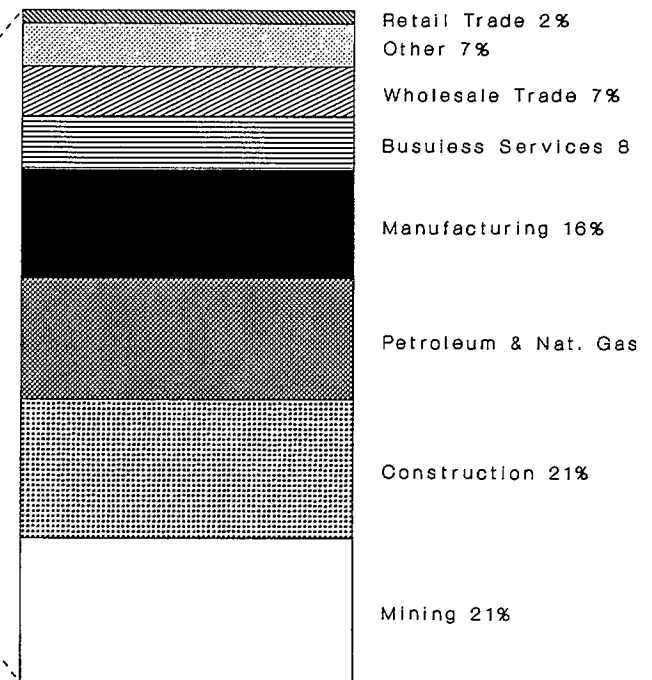

Industrial Sectors

direct investment only

# WORLD - ATLANTIC CANADA 1985-1990 OVERVIEW TOTAL FREQUENCIES

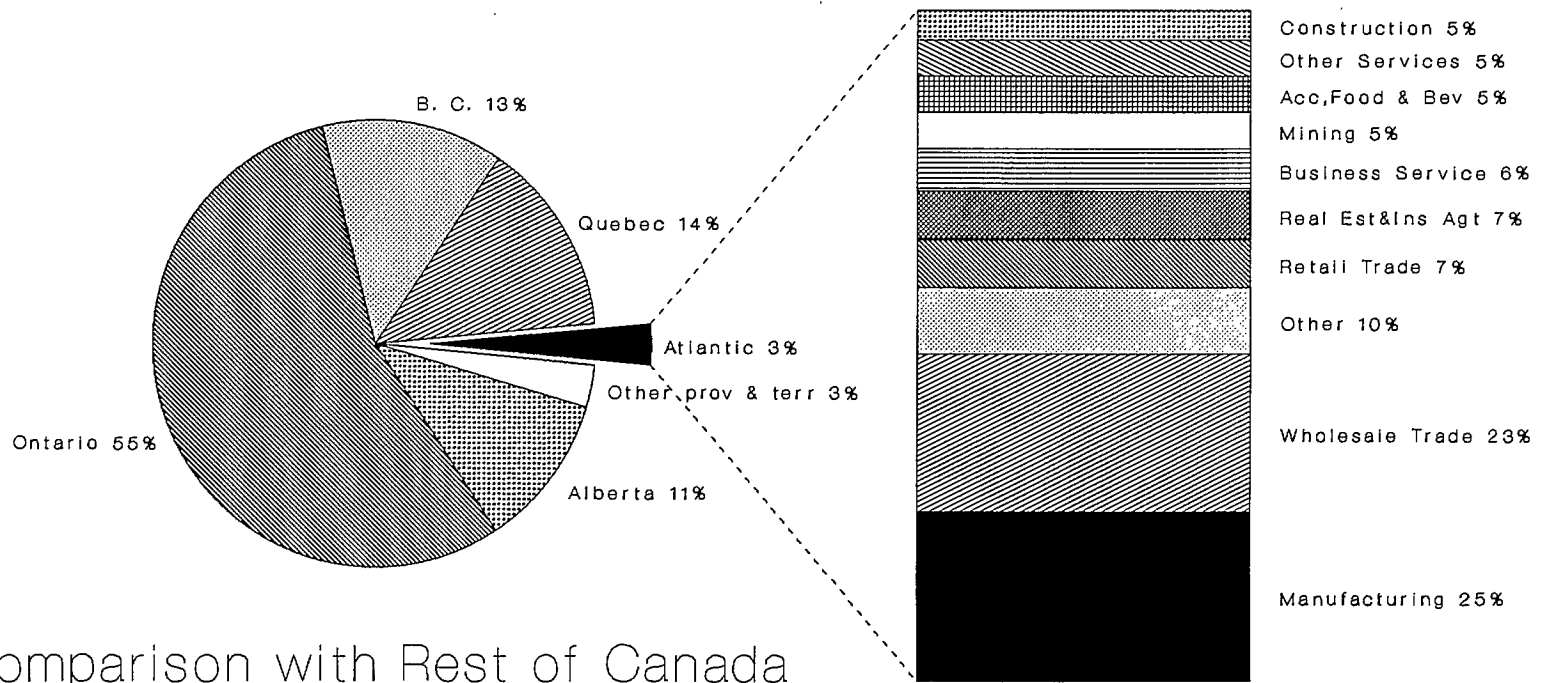

Industrial Sectors

direct investment only

# WORLD - ATLANTIC CANADA 1985-1990 OVERVIEW TOTAL FREQUENCIES

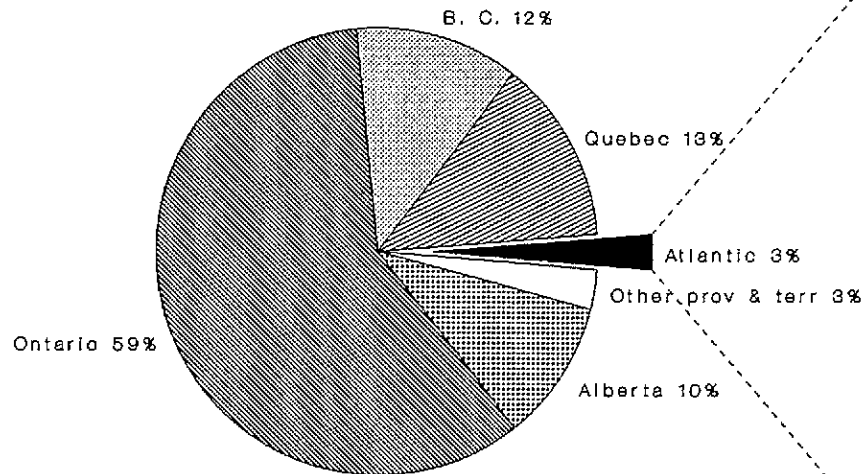

Comparison with Rest of Canada

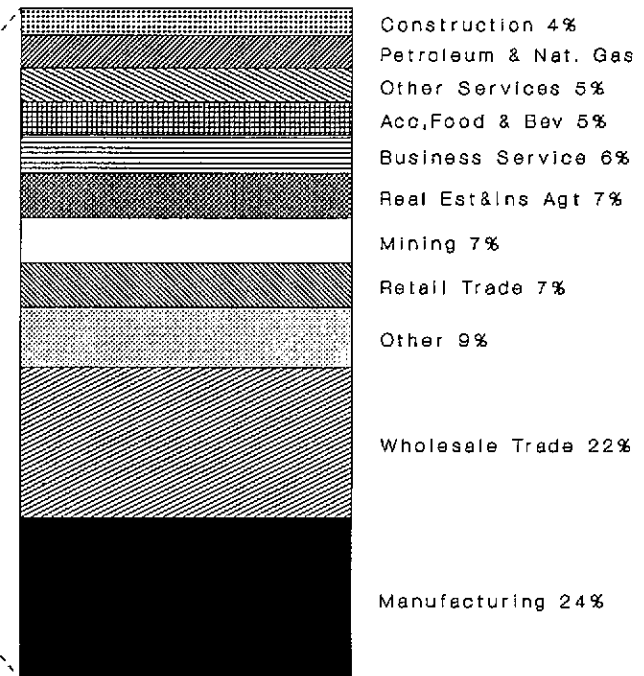

Industrial Sectors

includes direct, indirect and incidental investment

# WORLD - ATLANTIC CANADA 1985-1990

## TYPES OF INVESTMENT

### TOTAL ASSETS

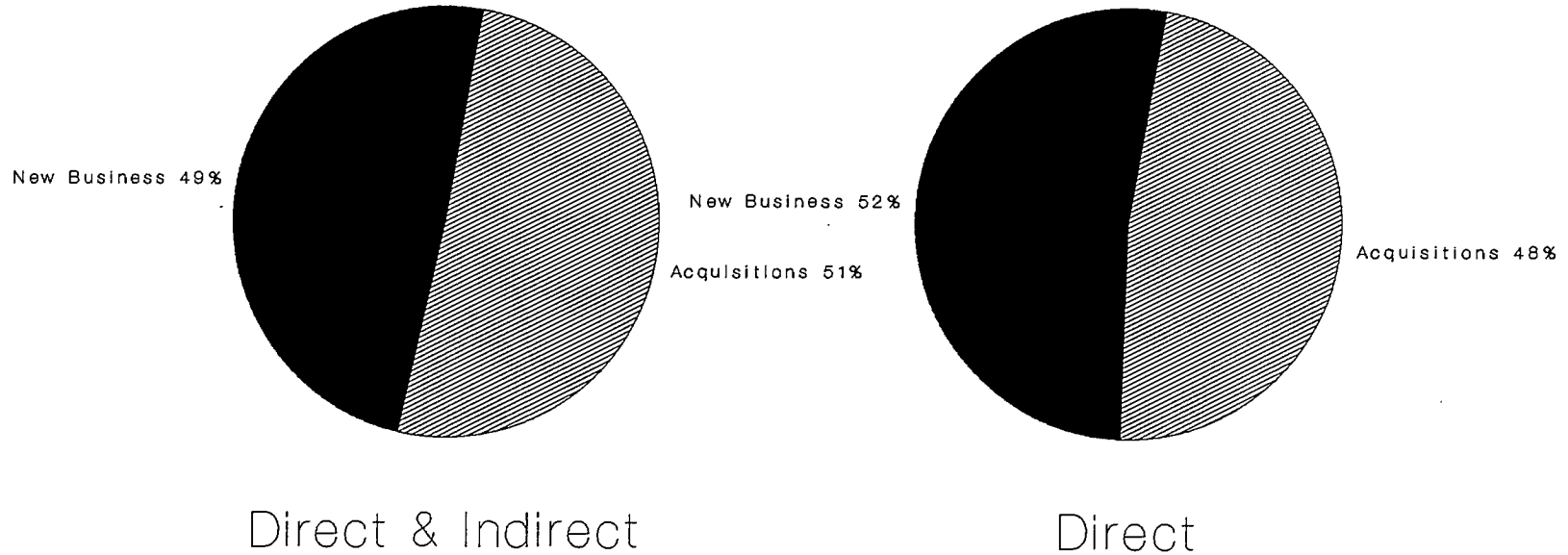

94% of the total asset value of investment is direct.

# WORLD -ATLANTIC CANADA 1985-1990

## TYPES OF INVESTMENT

### TOTAL FREQUENCIES

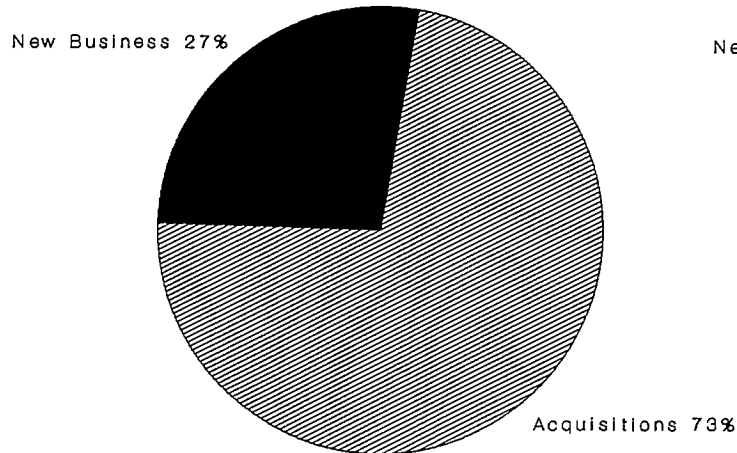

Direct & Indirect

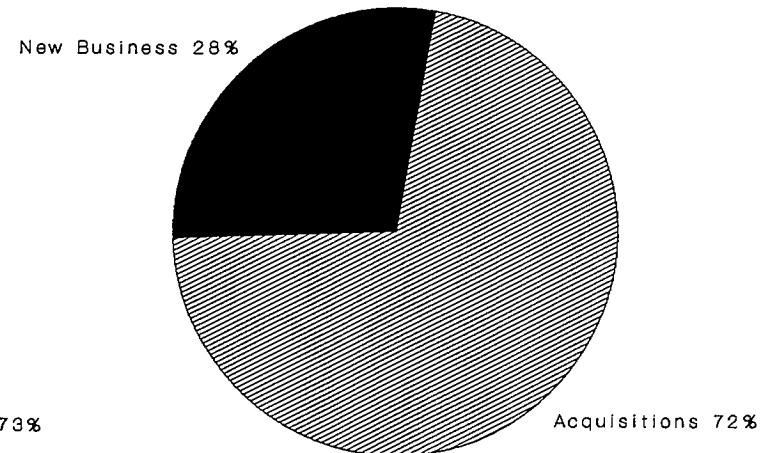

Direct

97% of the total frequency of investment is direct.

# **WORLD - QUEBEC - AN OVERVIEW**

## **OVERVIEW**

Quebec is the second most popular destination of all foreign investment with 18% of the asset value and 13% of the frequency of the total.

## **TYPES OF INVESTMENT**

79% of the asset value and 88% of the frequency of investment is direct. New business accounts for 16% of the asset value and 32% of the frequency of direct investment.

## **INDUSTRY SECTORS**

Manufacturing is the preferred sector with 69% of the total asset value and 35% of the total frequency of investment transactions. Mining (8%) and wholesale trade (8%) also attract significant portions of the asset value of investment. After manufacturing, wholesale trade (28%) and business services (11%) are the most frequent targets of investors. These sectors are characterized by high number of low asset value transactions involving new businesses.

# WORLD - QUEBEC 1985-1990 OVERVIEW TOTAL ASSETS

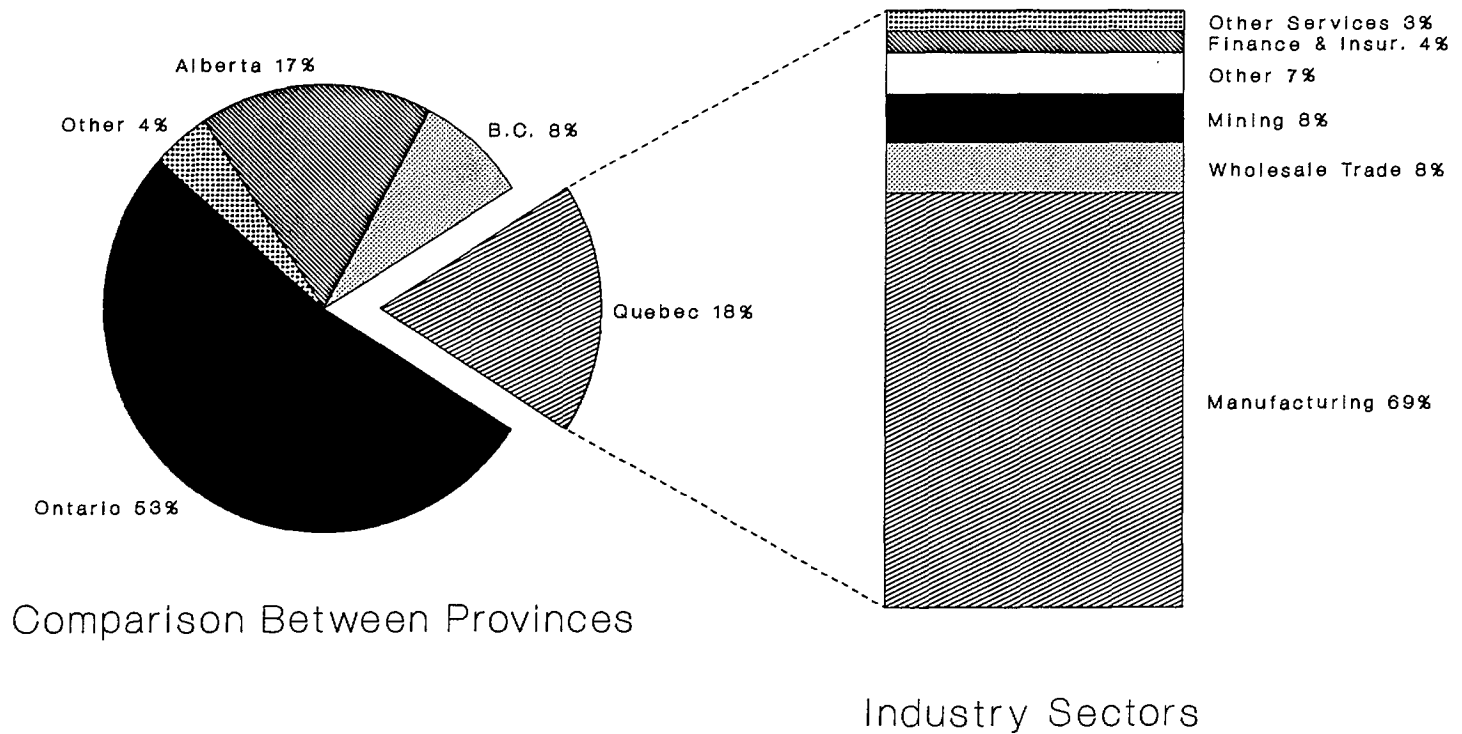

**includes direct, indirect and incidental investment**



# WORLD - QUEBEC 1985-1990 OVERVIEW TOTAL FREQUENCIES

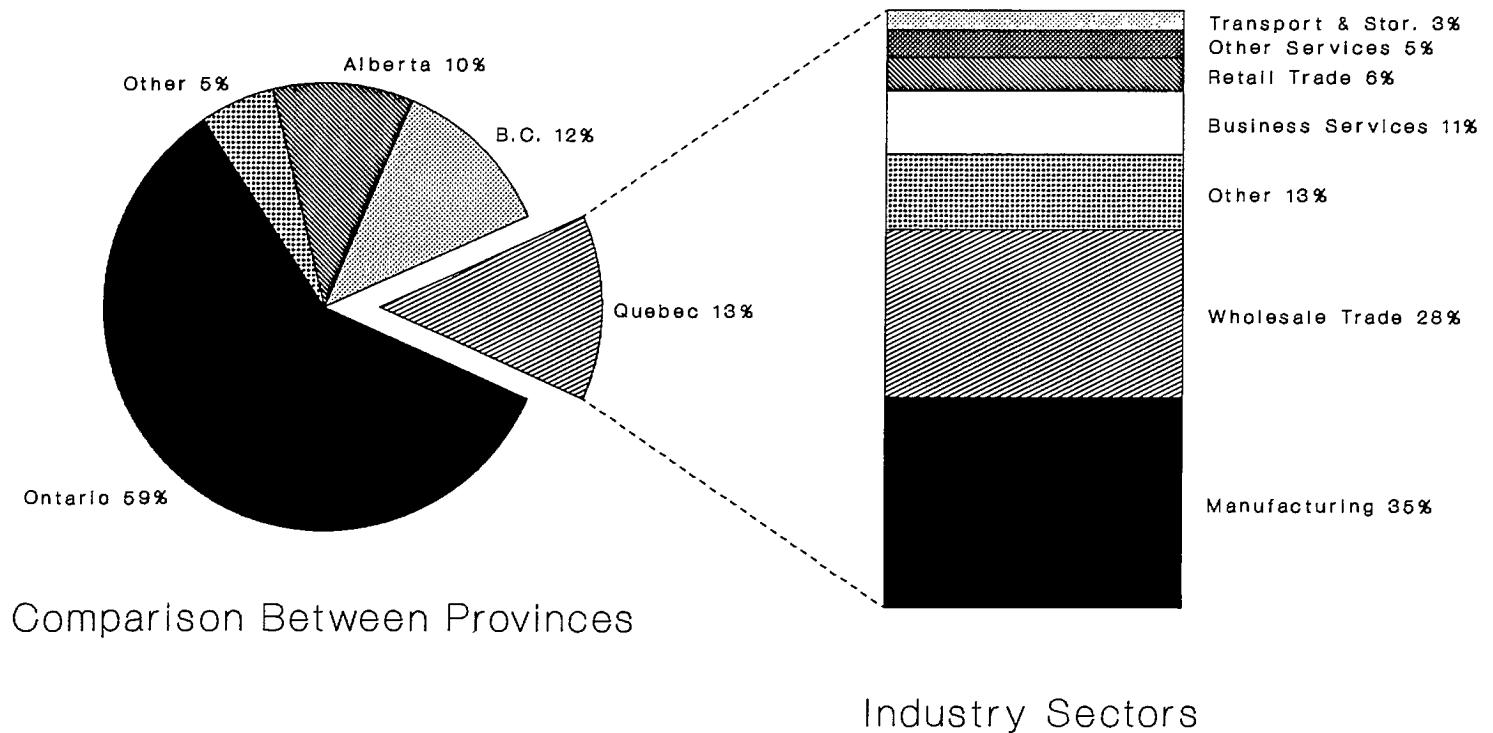

includes direct, indirect and incidental investment

# WORLD - QUEBEC 1985-1990 OVERVIEW TOTAL ASSETS

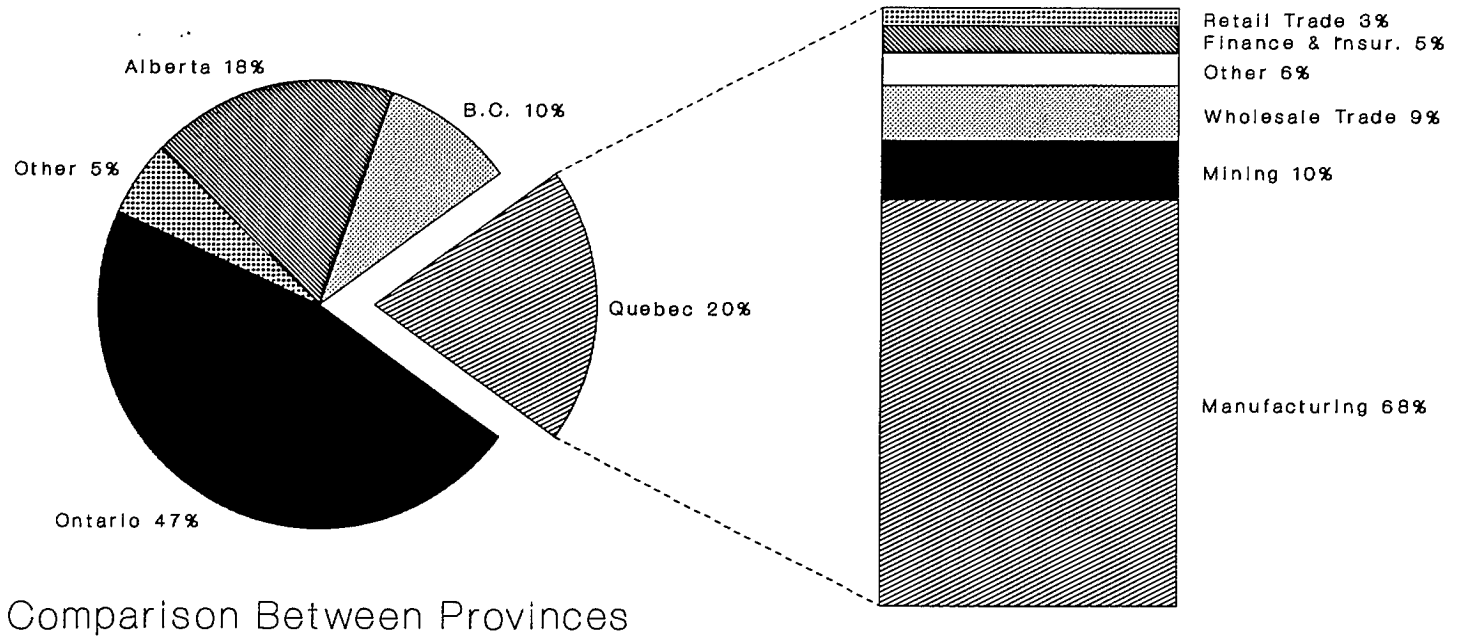

Comparison Between Provinces

Industry Sectors

direct investment only

# WORLD - QUEBEC 1985-1990 OVERVIEW TOTAL FREQUENCIES

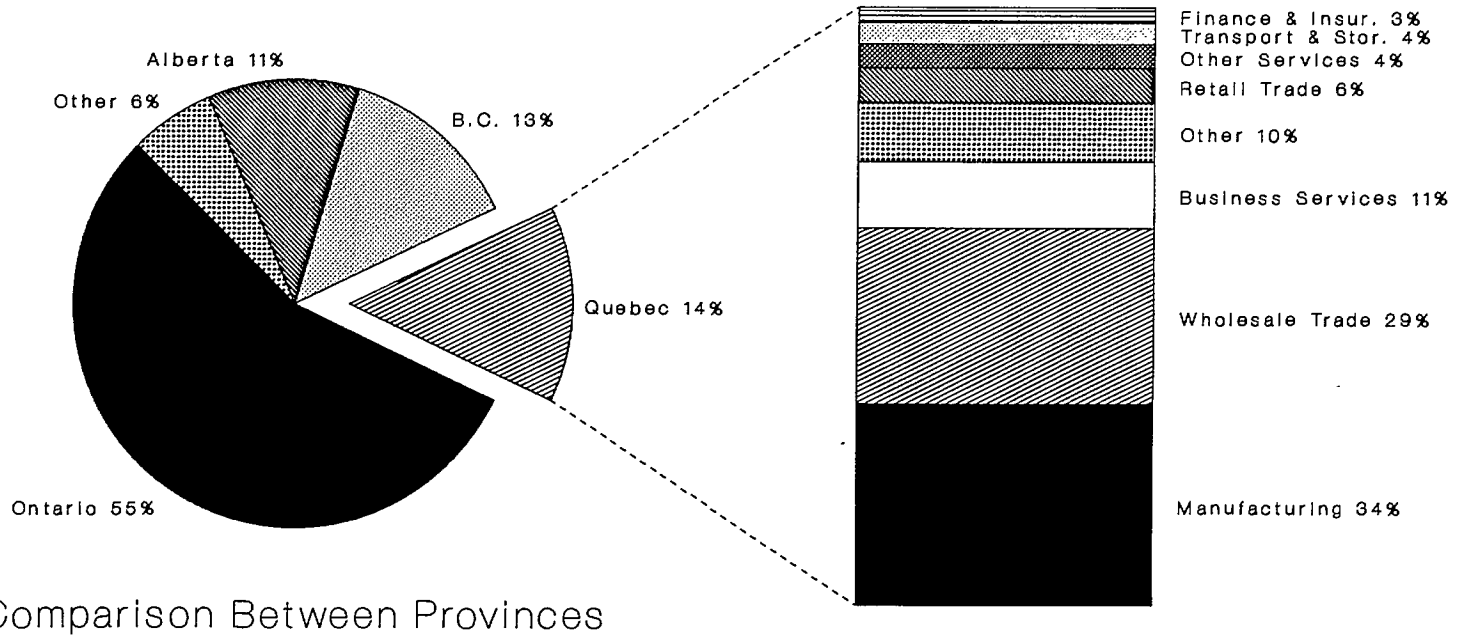

direct investment only

# WORLD - QUEBEC 1985-1990

## TYPES OF INVESTMENT

### TOTAL ASSETS

Acquisitions 87%

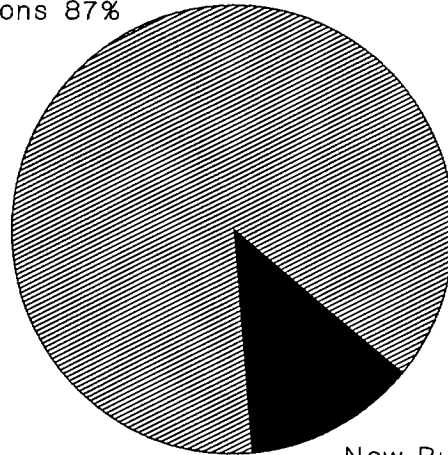

New Business 13%

Direct, Indirect and Incidental

Acquisitions 84%

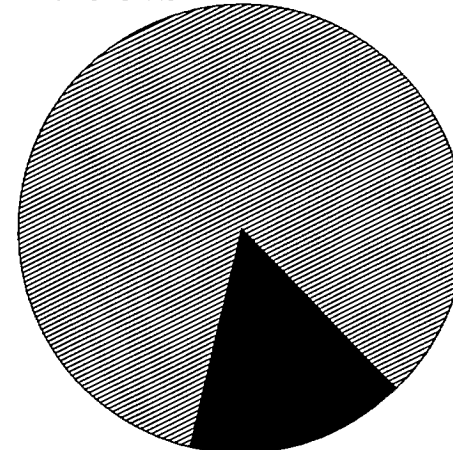

New Business 16%

Direct

**79% of the asset value of investment was direct**

# WORLD - QUEBEC 1985-1990

## TYPES OF INVESTMENT

### TOTAL FREQUENCIES

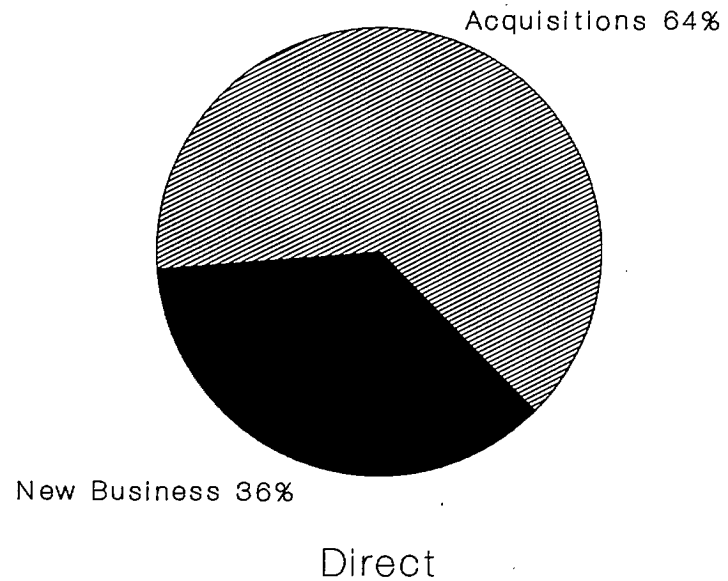
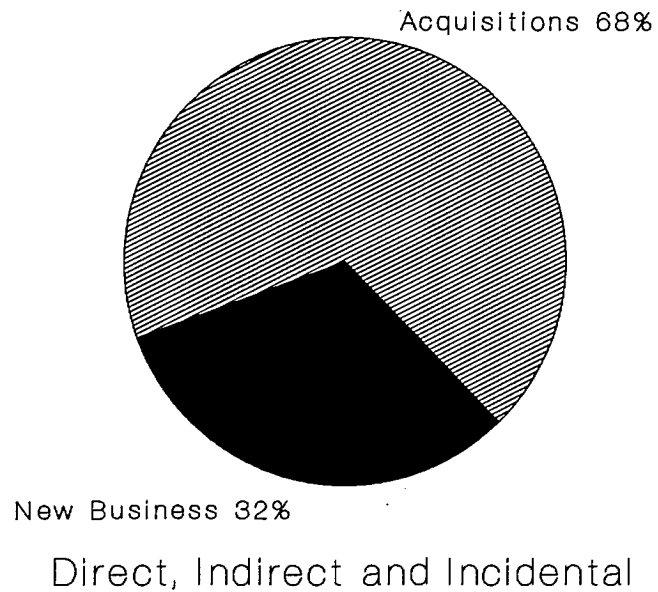

**88% of the total number of transactions were direct**

# WORLD - QUEBEC 1985-1990

## INDUSTRY SECTORS

### TOTAL ASSETS

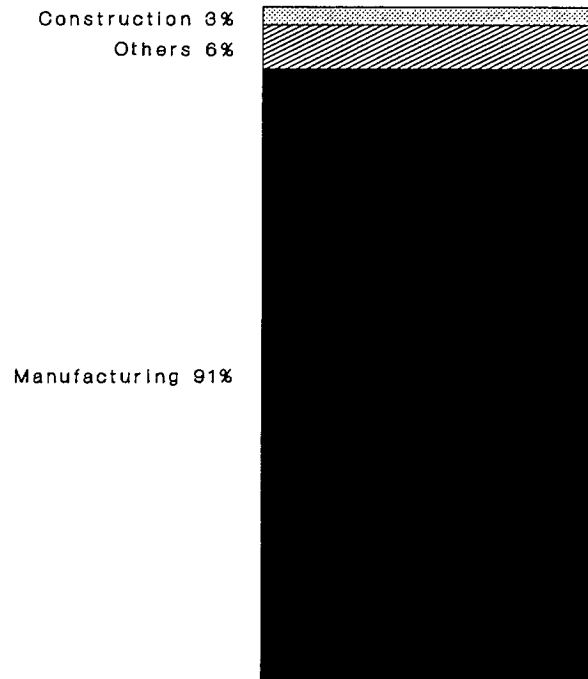

New Business

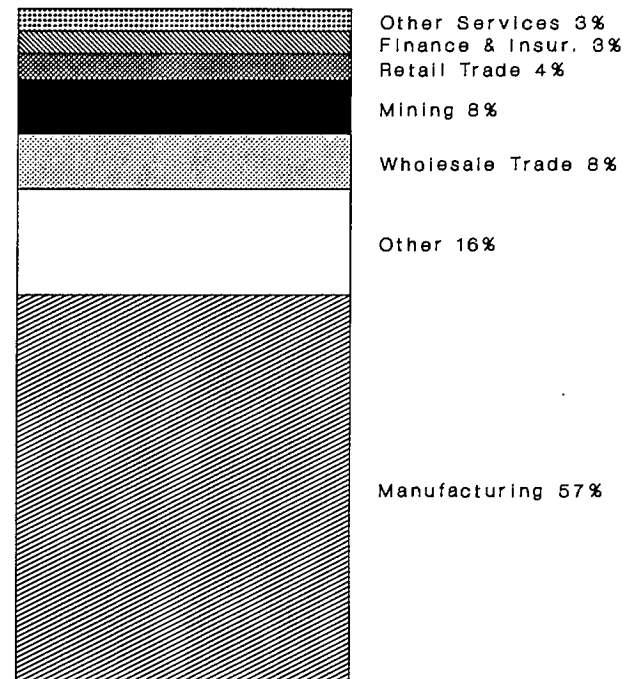

Acquisitions

**includes direct, indirect and incidental investment**

# WORLD - QUEBEC 1985-1990

## INDUSTRY SECTORS

### TOTAL FREQUENCIES

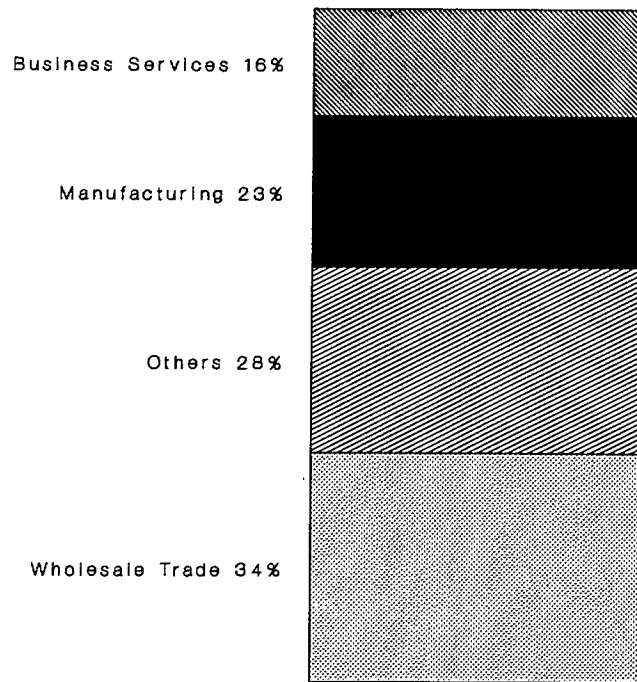

New Business

**includes direct, indirect and incidental investment**

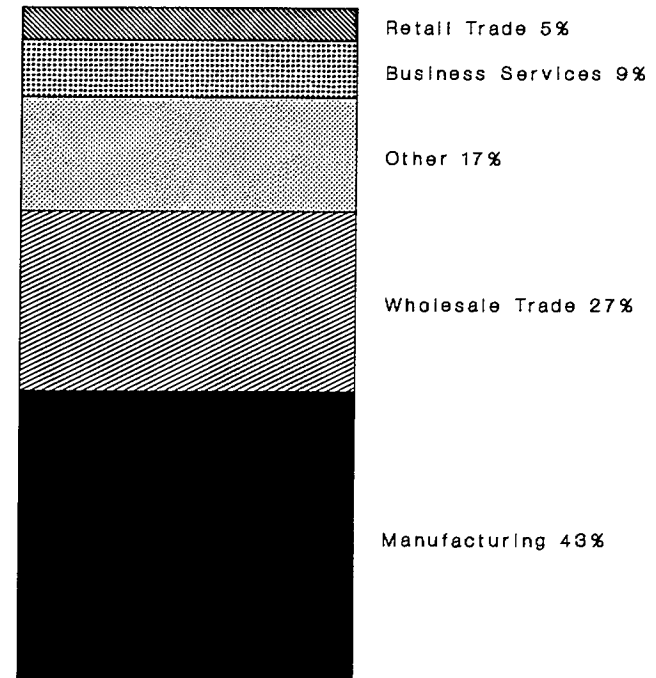

Acquisitions

# WORLD - QUEBEC 1985-1990

## INDUSTRY SECTORS

### TOTAL ASSETS

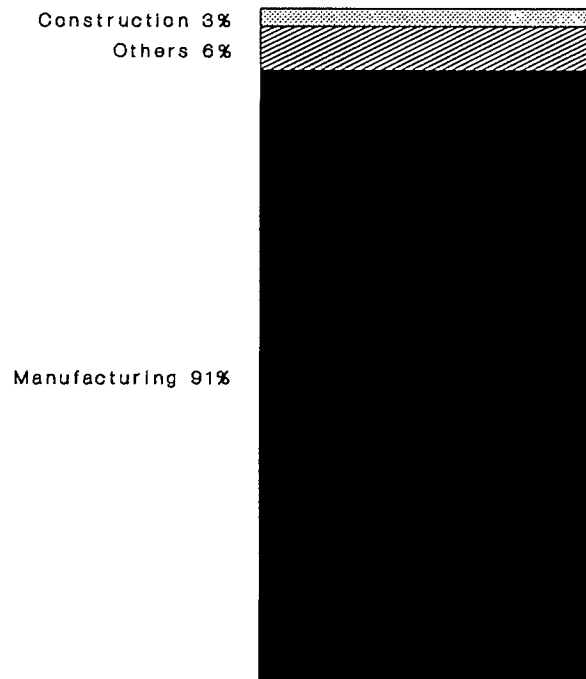

New Business

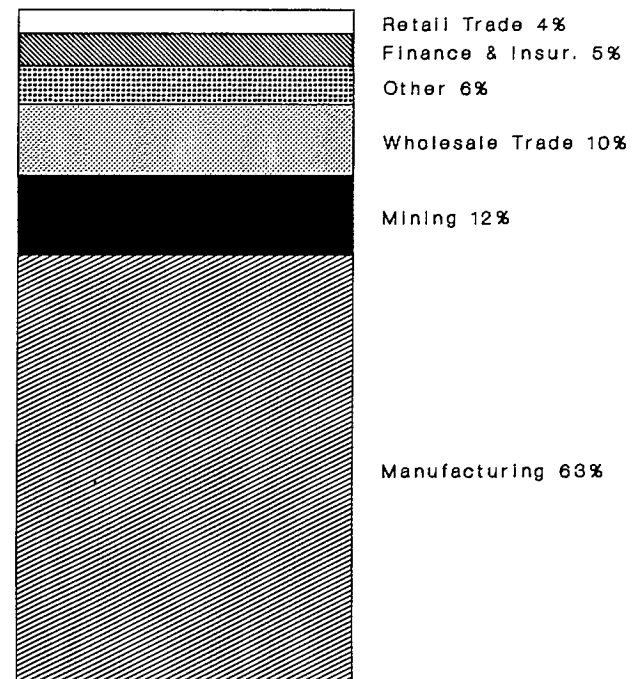

Acquisitions

**direct investment only**



# WORLD - QUEBEC 1985-1990

## INDUSTRY SECTORS

### TOTAL FREQUENCIES

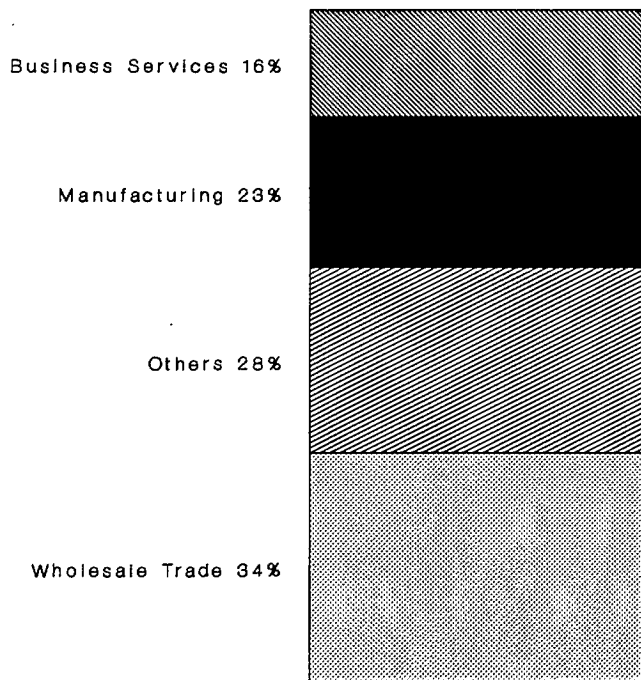

New Business

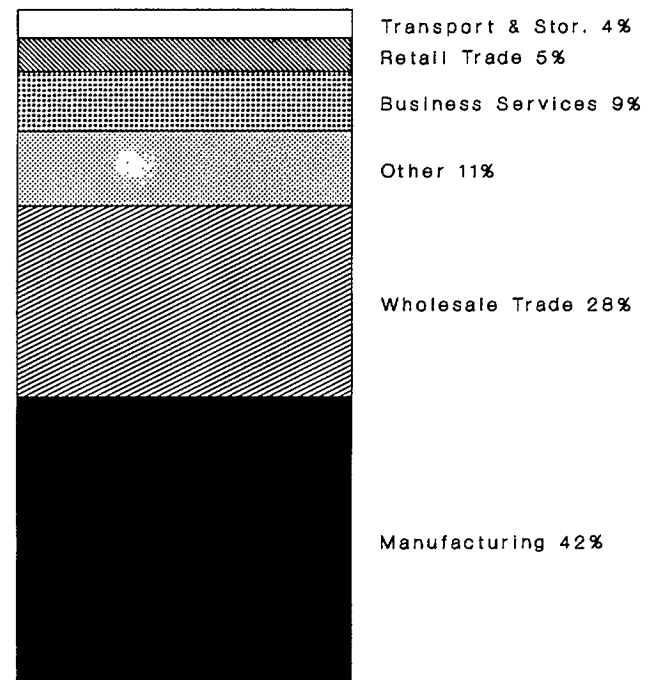

Acquisitions

**direct investment only**

# **WORLD - ONTARIO - AN OVERVIEW**

## **OVERVIEW**

Ontario is the most popular destination of investment by all foreign investors with 53% of the asset value and 59% of the frequency of the total.

## **TYPES OF INVESTMENT**

64% of the asset value and 78% of the frequency of investment is direct. New business accounts for only 5% of the asset value of direct investment. However, 39% of the total number of direct transactions are new businesses. Large asset values involved in acquisitions, of manufacturing, petroleum and natural gas, and mining operations overshadow the asset value of investment in new business.

## **INDUSTRY SECTORS**

Manufacturing is the preferred sector with 52% of the total asset value and 38% of the total frequency of investment transactions. Petroleum and natural gas (9%), mining (7%), and finance and insurance (7%) attract significant portions of the asset value of investment. However, these sectors draw very low frequencies of transactions. After manufacturing, wholesale trade (26%) and business services (11%) are the most frequent targets of investors. Both these sectors are also popular choices for new businesses.

# WORLD - ONTARIO 1985-1990 OVERVIEW TOTAL ASSETS

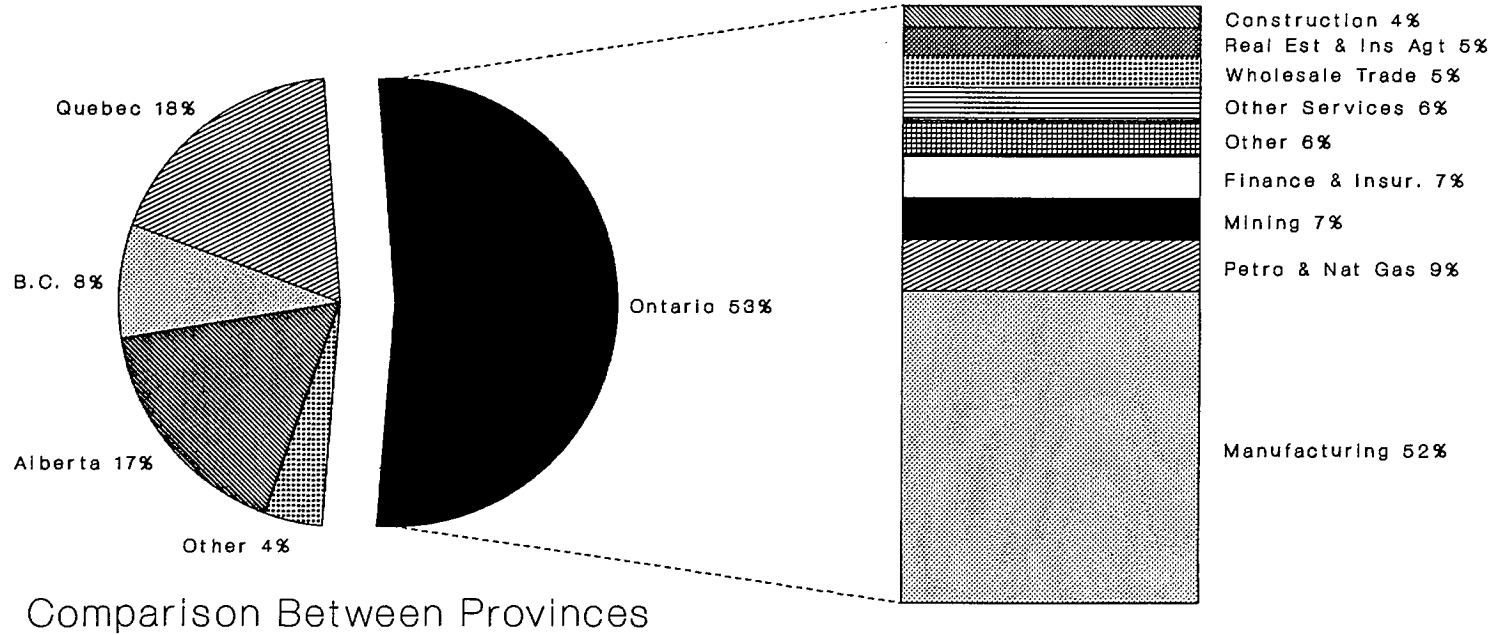

**includes direct, indirect and incidental investment**

# WORLD - ONTARIO 1985-1990 OVERVIEW TOTAL FREQUENCIES

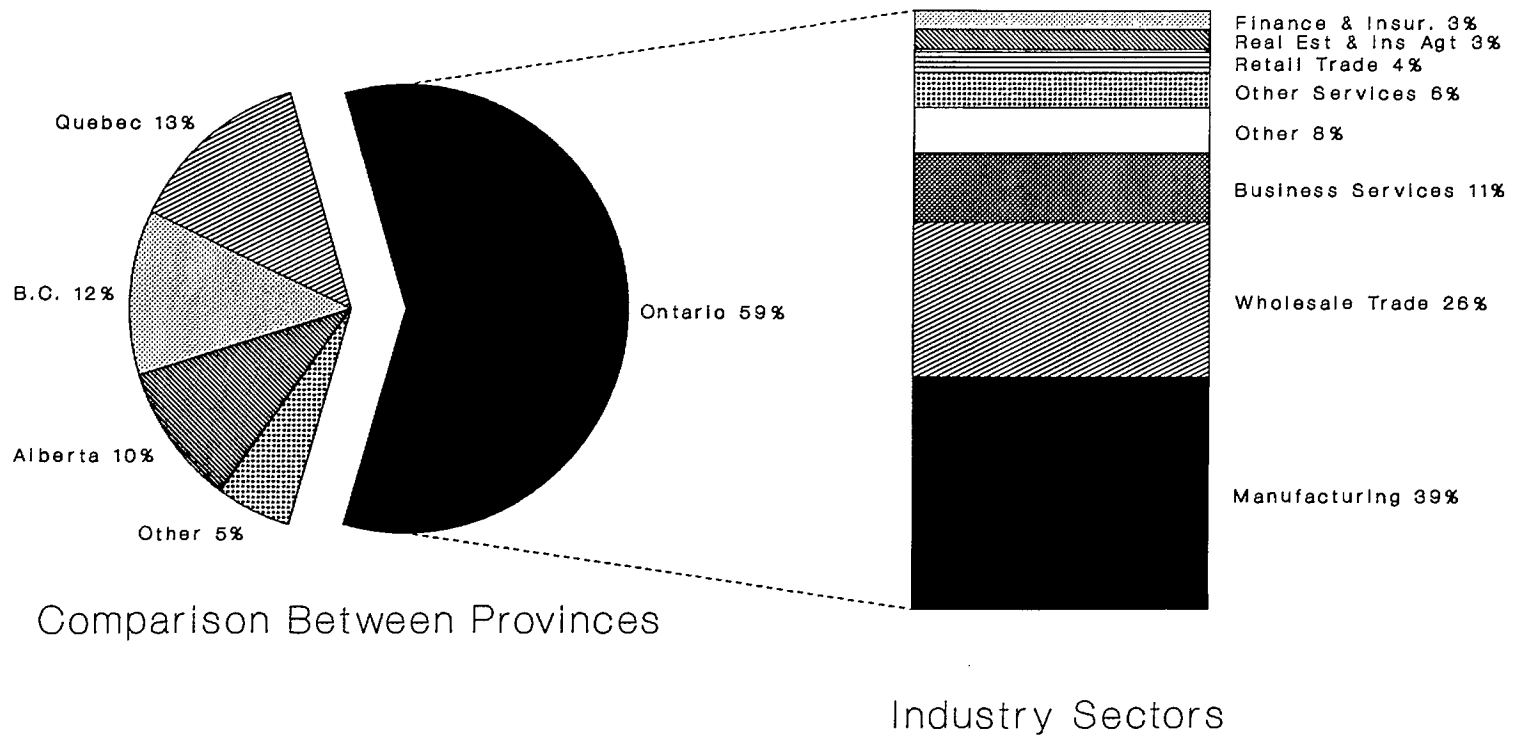

**includes direct, indirect and incidental investment**

# WORLD - ONTARIO 1985-1990 OVERVIEW TOTAL ASSETS

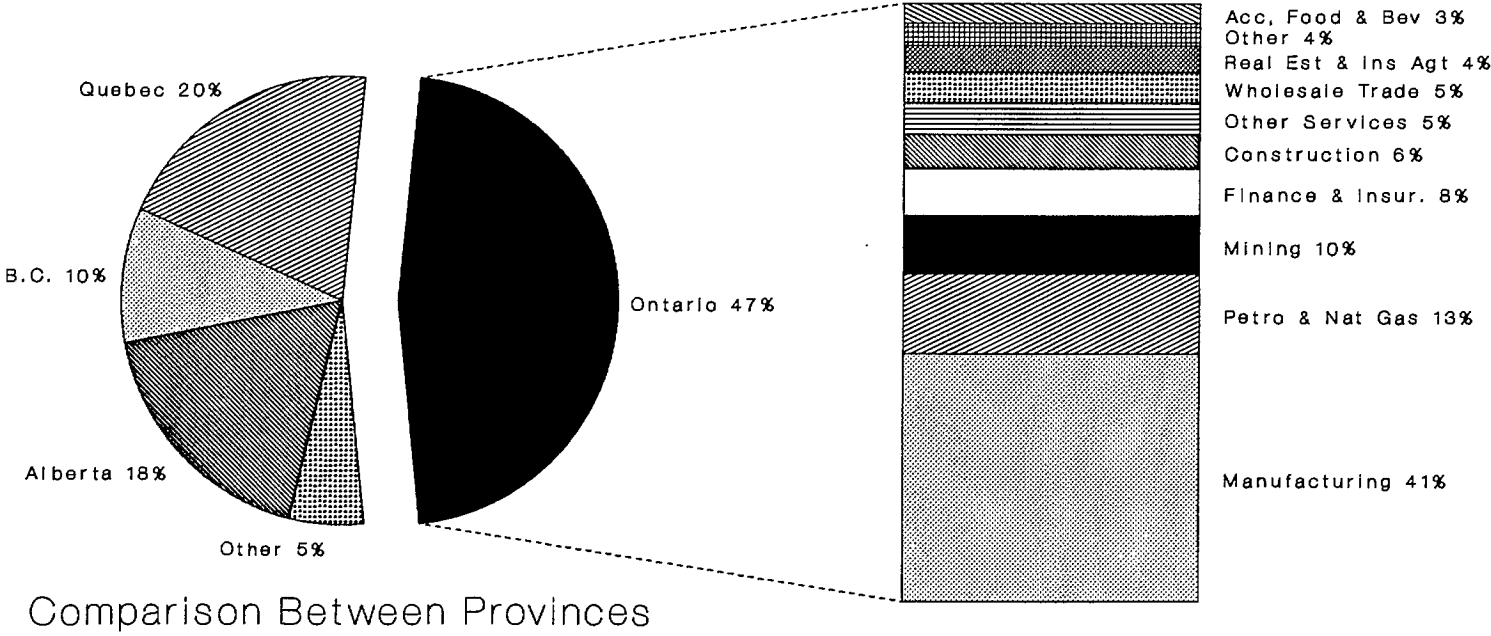

**direct investment only**

# WORLD - ONTARIO 1985-1990 OVERVIEW TOTAL FREQUENCIES

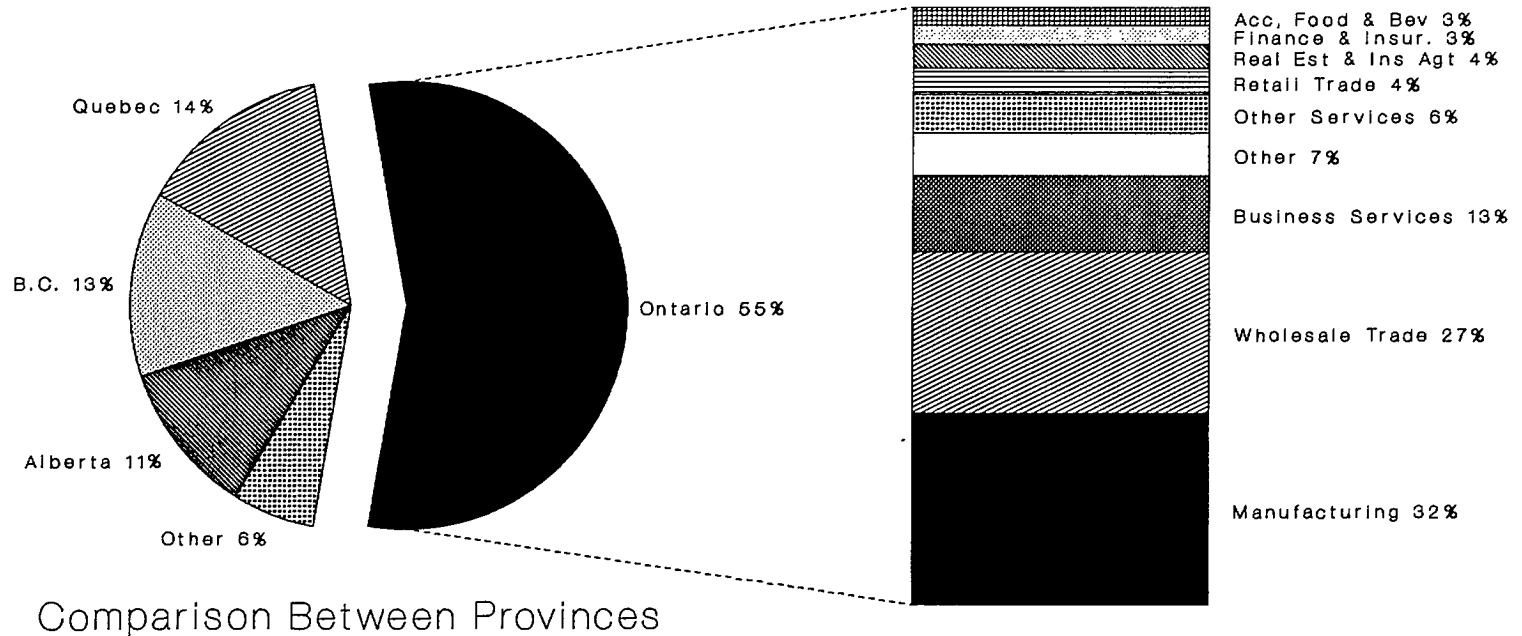

**direct investment only**

# WORLD - ONTARIO 1985-1990

## TYPES OF INVESTMENT

### TOTAL ASSETS

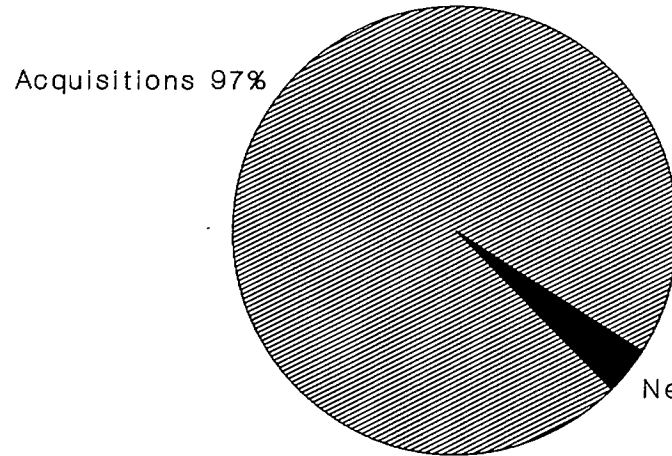

Direct, Indirect and Incidental

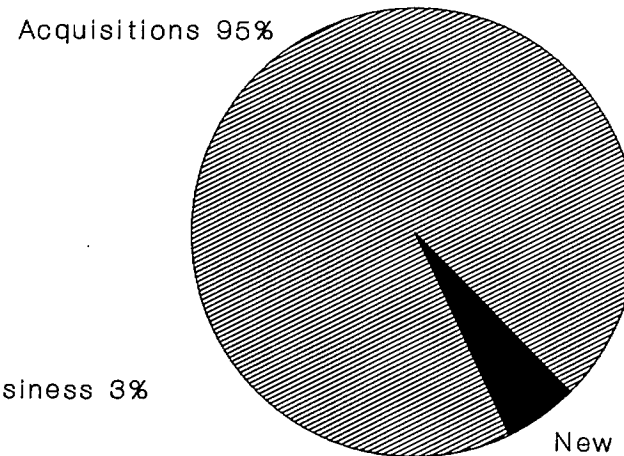

Direct

**64% of the asset value of investment was direct**

# WORLD - ONTARIO 1985-1990

## TYPES OF INVESTMENT

### TOTAL FREQUENCIES

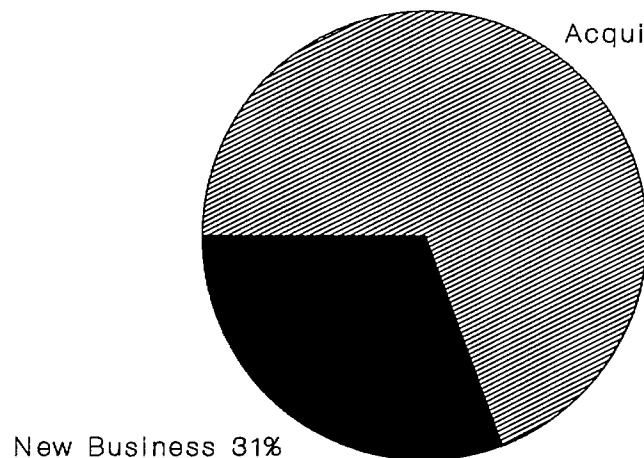

Direct, Indirect and Incidental

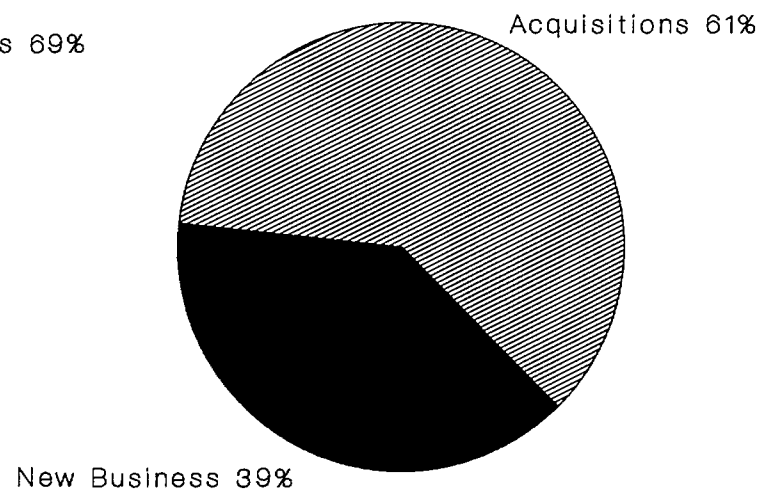

Direct

**78% of the total number of investment transactions were direct**



# WORLD - ONTARIO 1985-1990

## INDUSTRY SECTORS

### TOTAL ASSETS

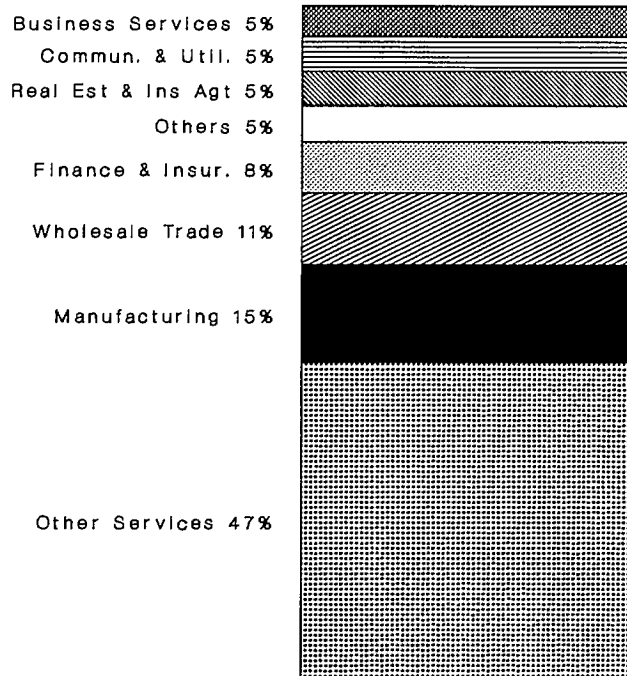

New Business

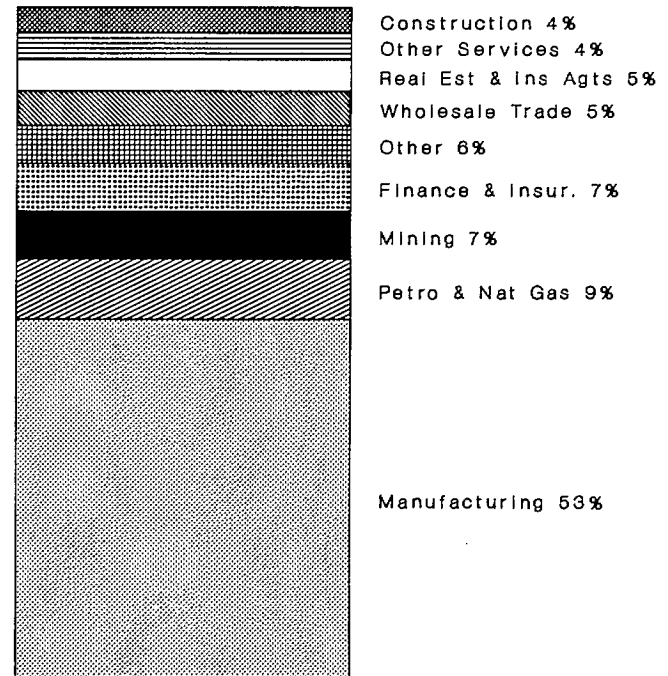

Acquisitions

**includes direct, indirect and incidental investment**

# WORLD - ONTARIO 1985-1990

## INDUSTRY SECTORS

### TOTAL FREQUENCIES

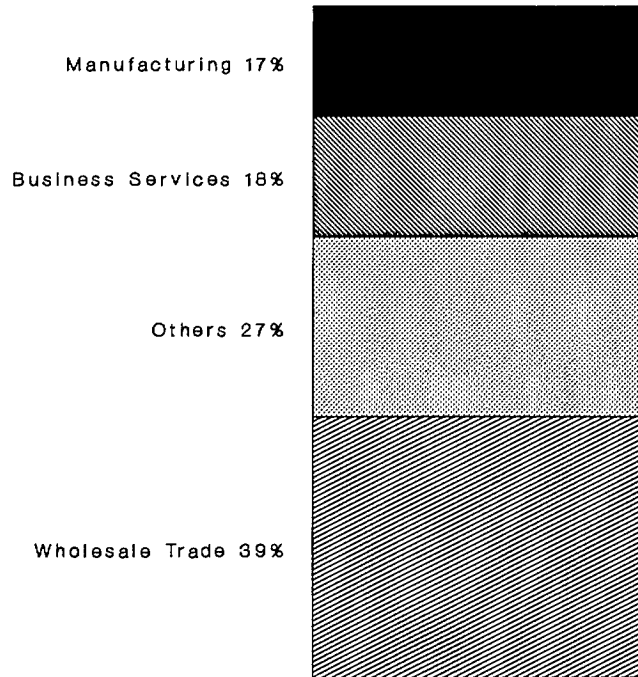

New Business

**includes direct, indirect and incidental investment**

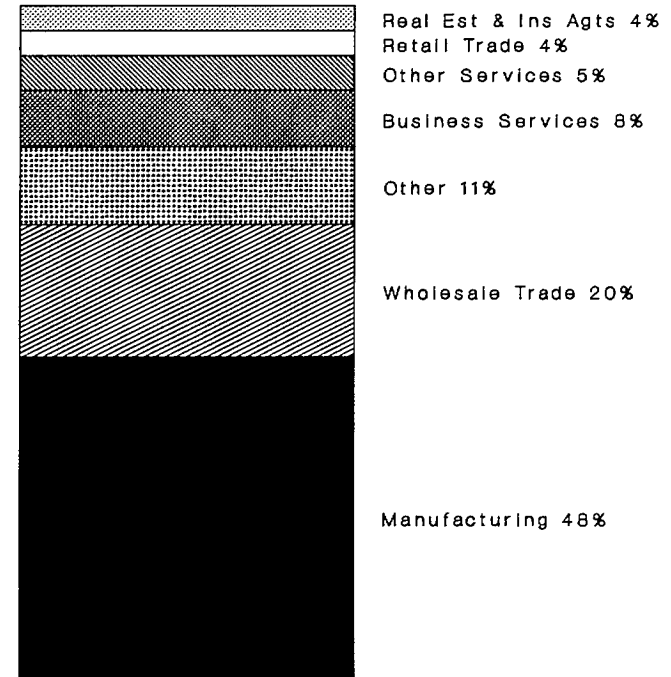

Acquisitions

# WORLD - ONTARIO 1985-1990

## INDUSTRY SECTORS

### TOTAL ASSETS

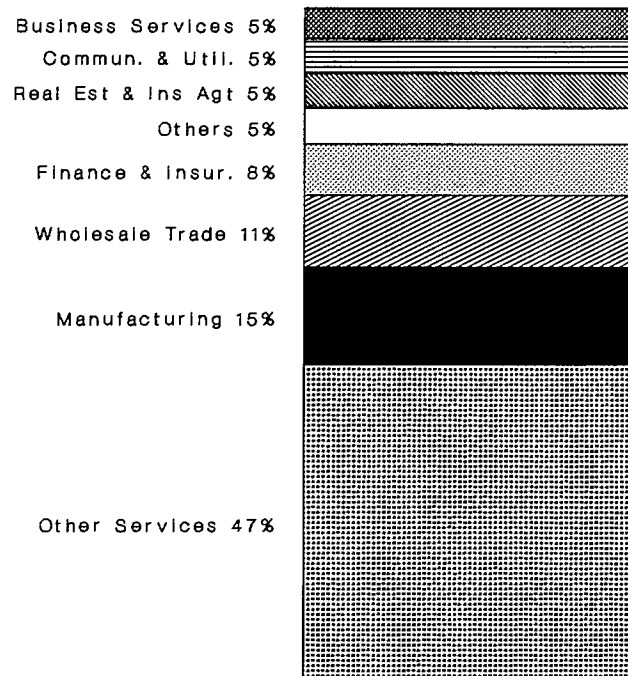

New Business

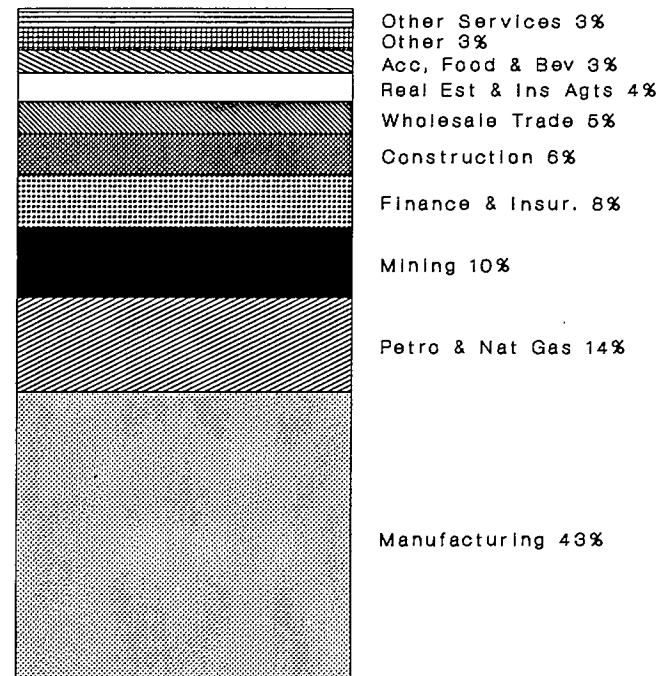

Acquisitions

**direct investment only**

# WORLD - ONTARIO 1985-1990

## INDUSTRY SECTORS

### TOTAL FREQUENCIES

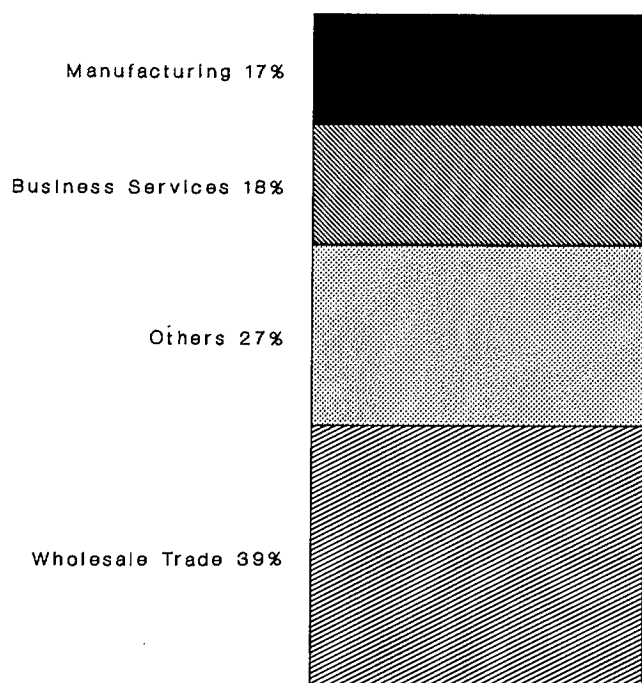

New Business

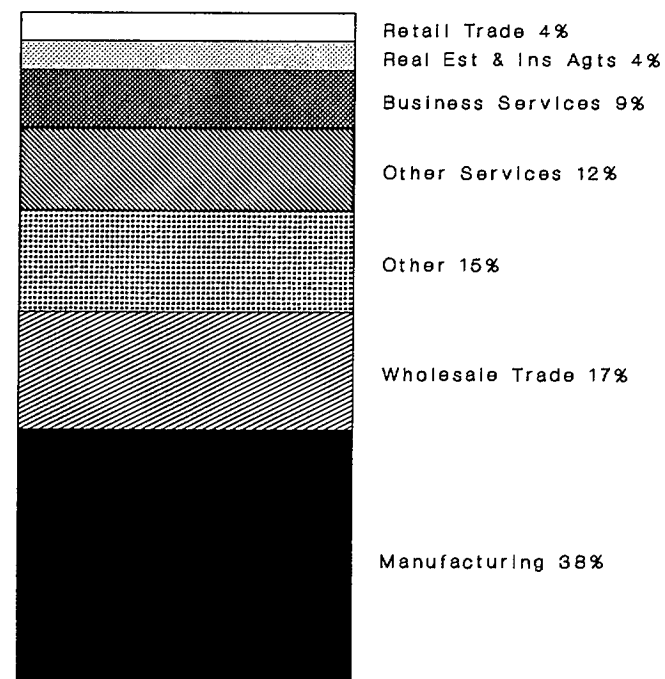

Acquisitions

direct investment only

# **WORLD - PRAIRIE PROVINCES - AN OVERVIEW**

## **OVERVIEW**

20% of the asset value and 13% of the frequency of foreign investment to Canada is made in the Prairie provinces. The divergence in asset values and frequencies is due to the popularity of mining, and petroleum and natural gas industries, which are characterized by high asset values and low frequencies of investment.

## **COMPARISON BETWEEN PROVINCES**

Alberta is by far the preferred destination with 87% of the total asset value and 80% of the frequency of investment. Manitoba, much less reliant on capital intensive industries, receives a small portion of the asset value (5%) and a larger portion of the frequency (13%) of foreign investment to the Prairies. Saskatchewan secures 8% of the asset value and 7% of the frequency of investment.

## **TYPES OF INVESTMENT**

78% of the asset value and 90% of the frequency of investment is direct. New business accounts for 6% of the asset value and 27% of the frequency of direct investment.

## **INDUSTRY SECTORS**

Petroleum and natural gas industries are the primary targets of foreign investment with, 60% of the asset value, and 29% of the total frequency of investment. Manufacturing (13%), wholesale trade (8%), retail trade (6%), and mining (6%) also draw significant portions of the asset value of investment. The most frequently preferred sectors, after petroleum and natural gas, are manufacturing (21%), wholesale trade (17%), and business services (9%).

# WORLD - PRAIRIES 1985-1990 OVERVIEW TOTAL ASSETS

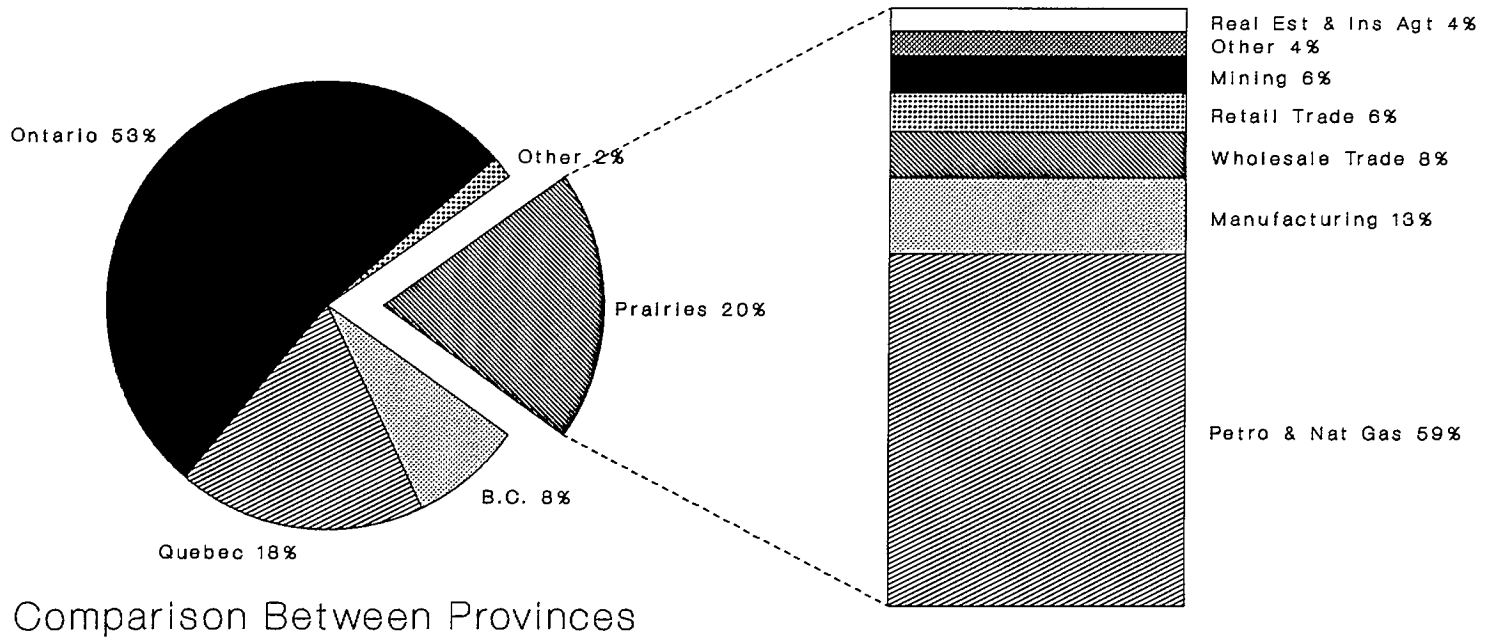

includes direct, indirect and incidental investment

# WORLD - PRAIRIES 1985-1990 OVERVIEW TOTAL FREQUENCIES

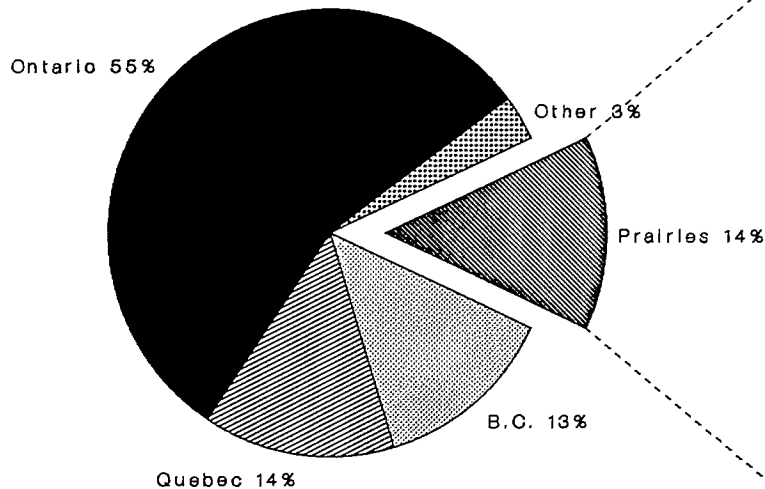

Comparison Between Provinces

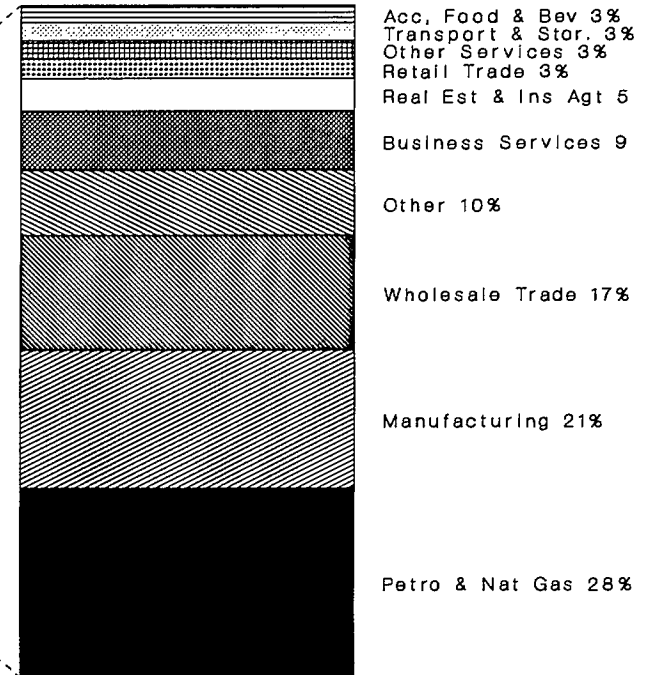

Industry Sectors

includes direct, indirect and incidental investment

# WORLD - PRAIRIES 1985-1990 OVERVIEW TOTAL ASSETS

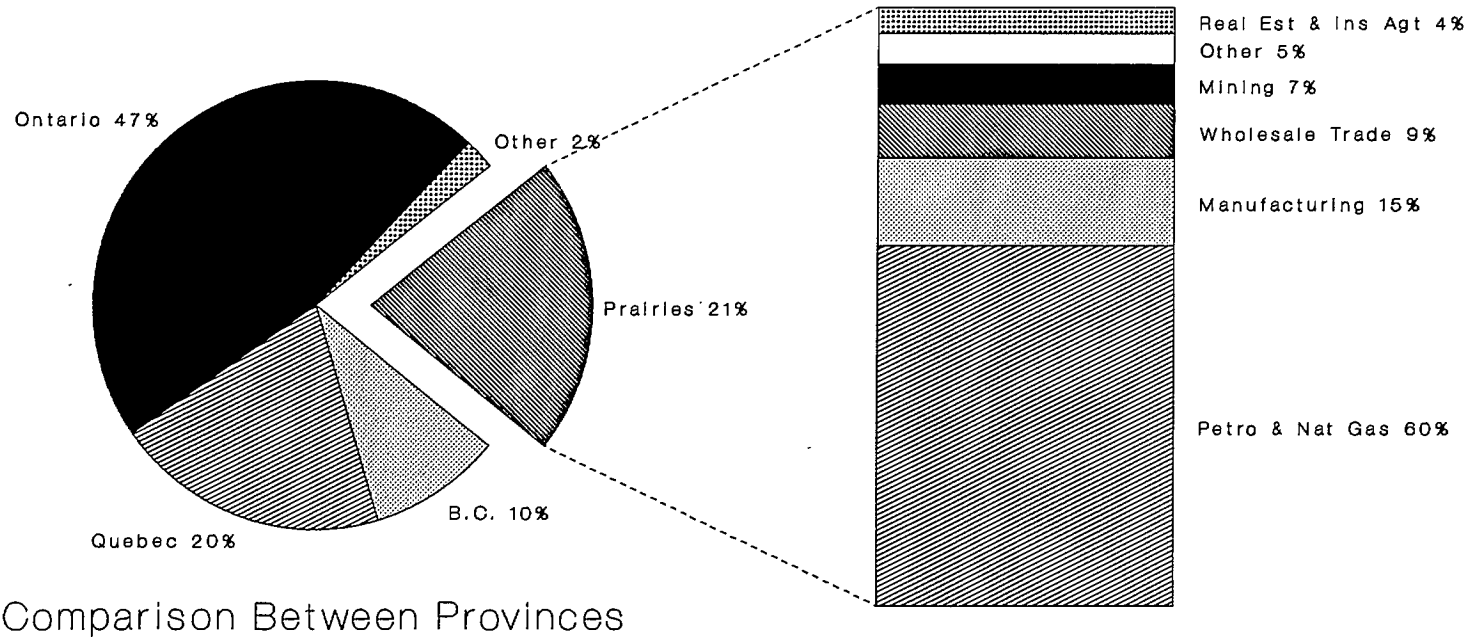

Comparison Between Provinces

Industry Sectors

direct investment only



# WORLD - PRAIRIES 1985-1990

## OVERVIEW

### TOTAL FREQUENCIES

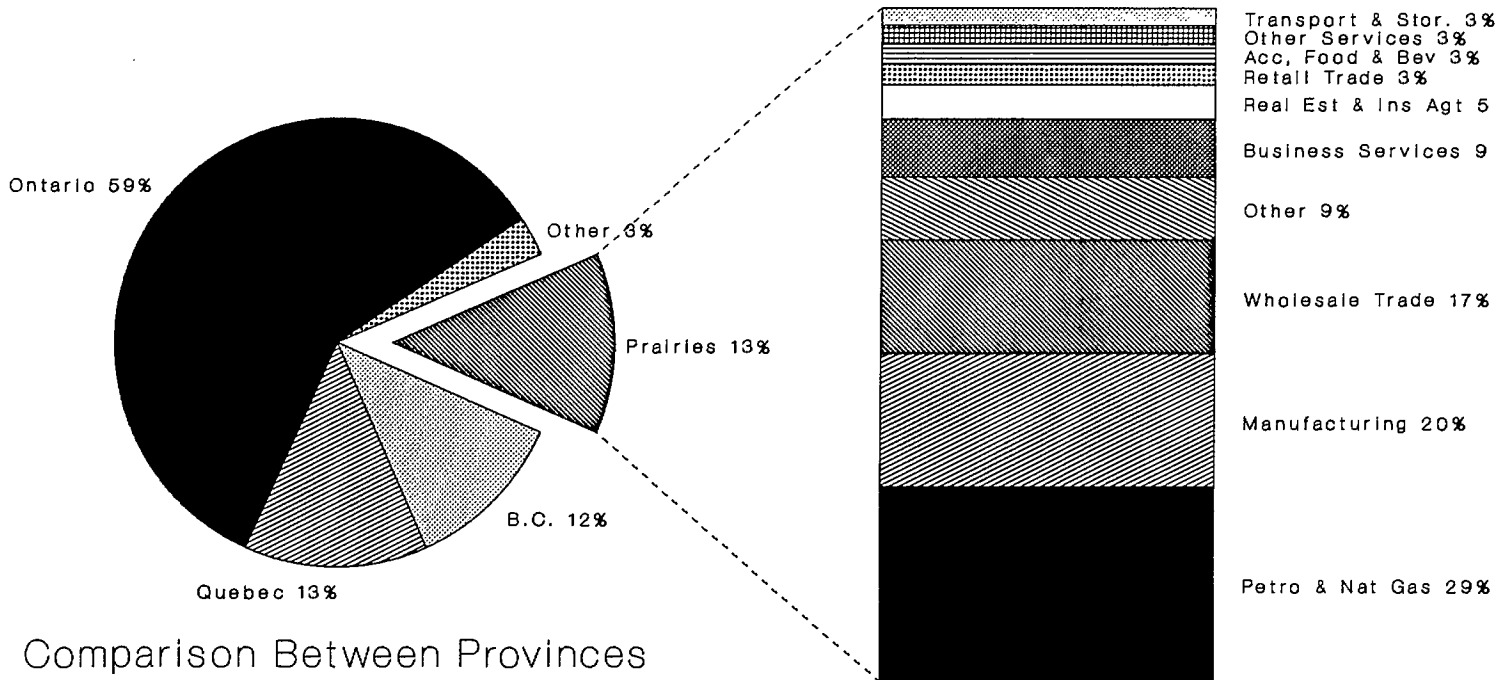

direct investment only

# WORLD - PRAIRIES 1985-1990 COMPARISON OF PROVINCES

Alberta 87%

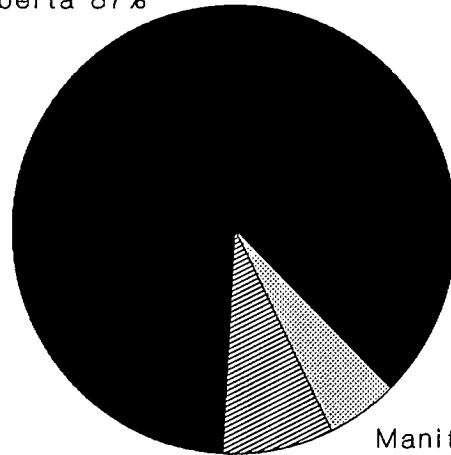

Manitoba 5%  
Saskatchewan 8%

Total Assets

Alberta 80%

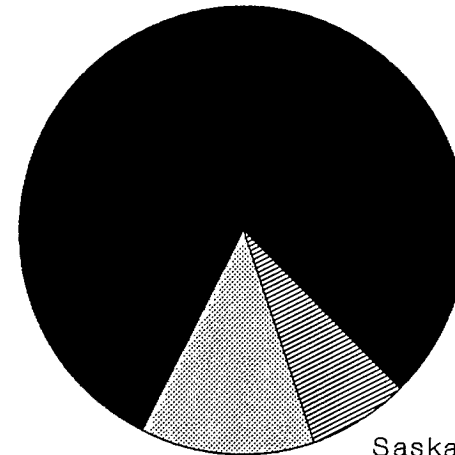

Manitoba 13%

Saskatchewan 7%

Total Frequencies

**includes direct, indirect and incidental  
investment**

# WORLD - PRAIRIES 1985-1990 COMPARISON OF PROVINCES

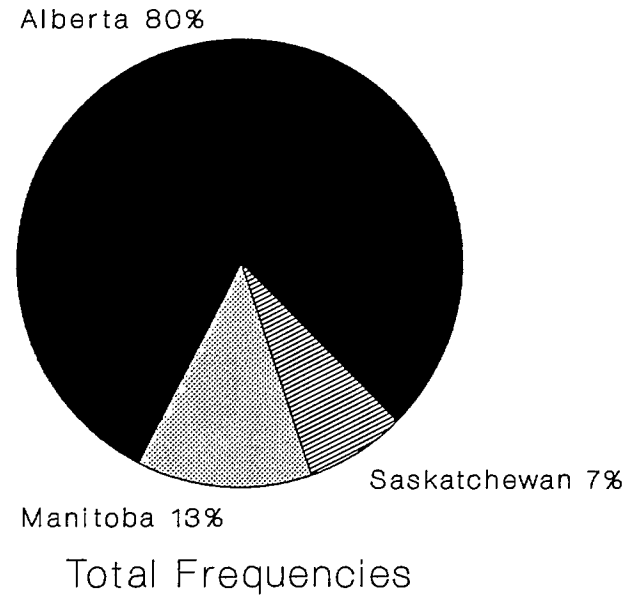
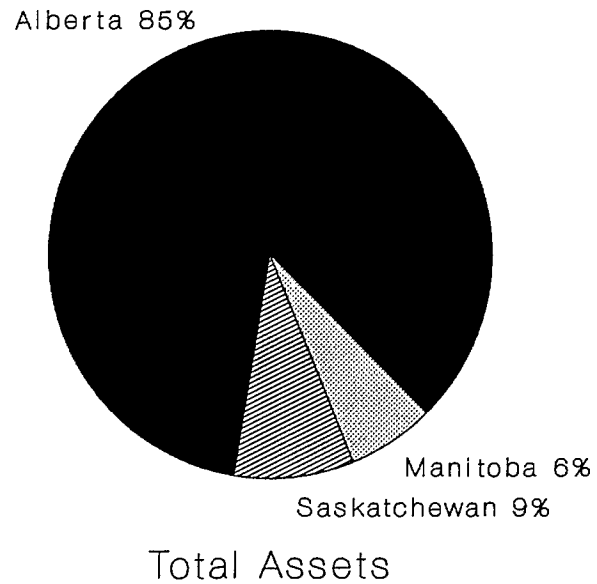

direct investment only

# WORLD - MANITOBA 1985-1990 OVERVIEW TOTAL ASSETS

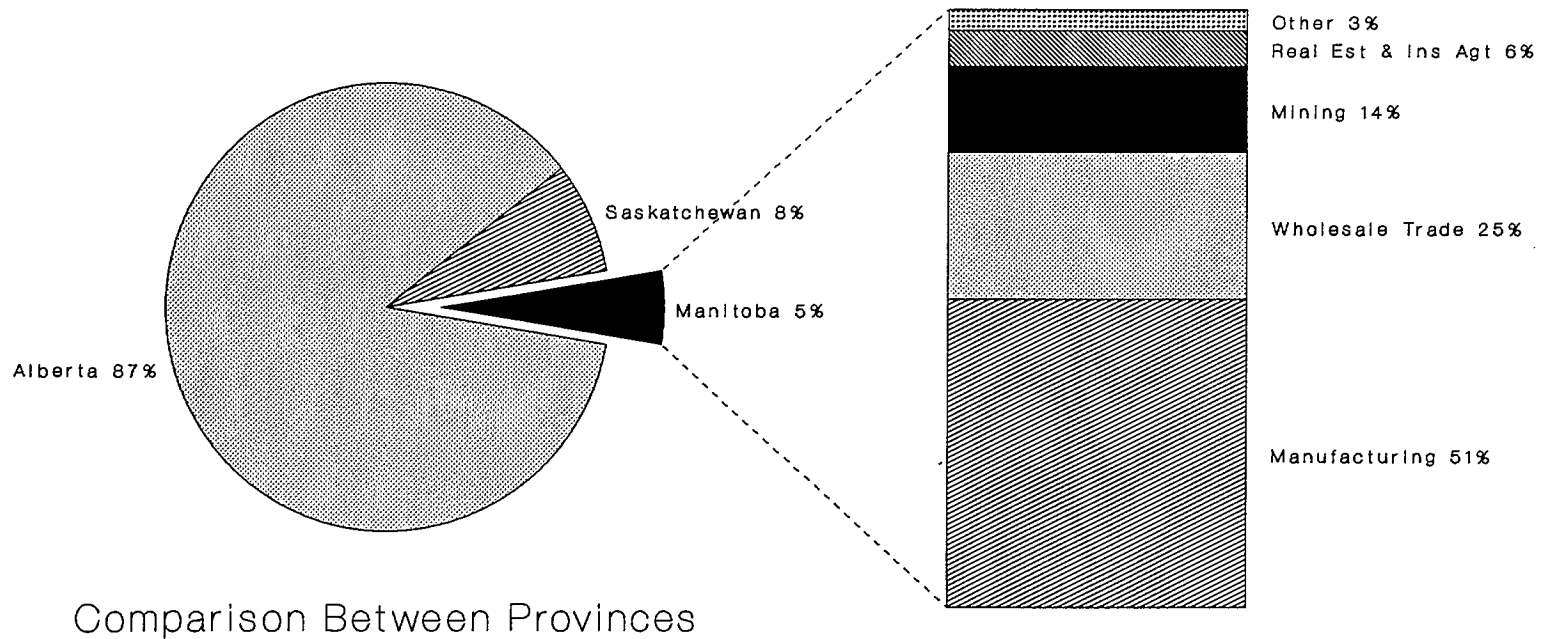

**includes direct, indirect and incidental investment**

# WORLD - MANITOBA 1985-1990 OVERVIEW TOTAL FREQUENCIES

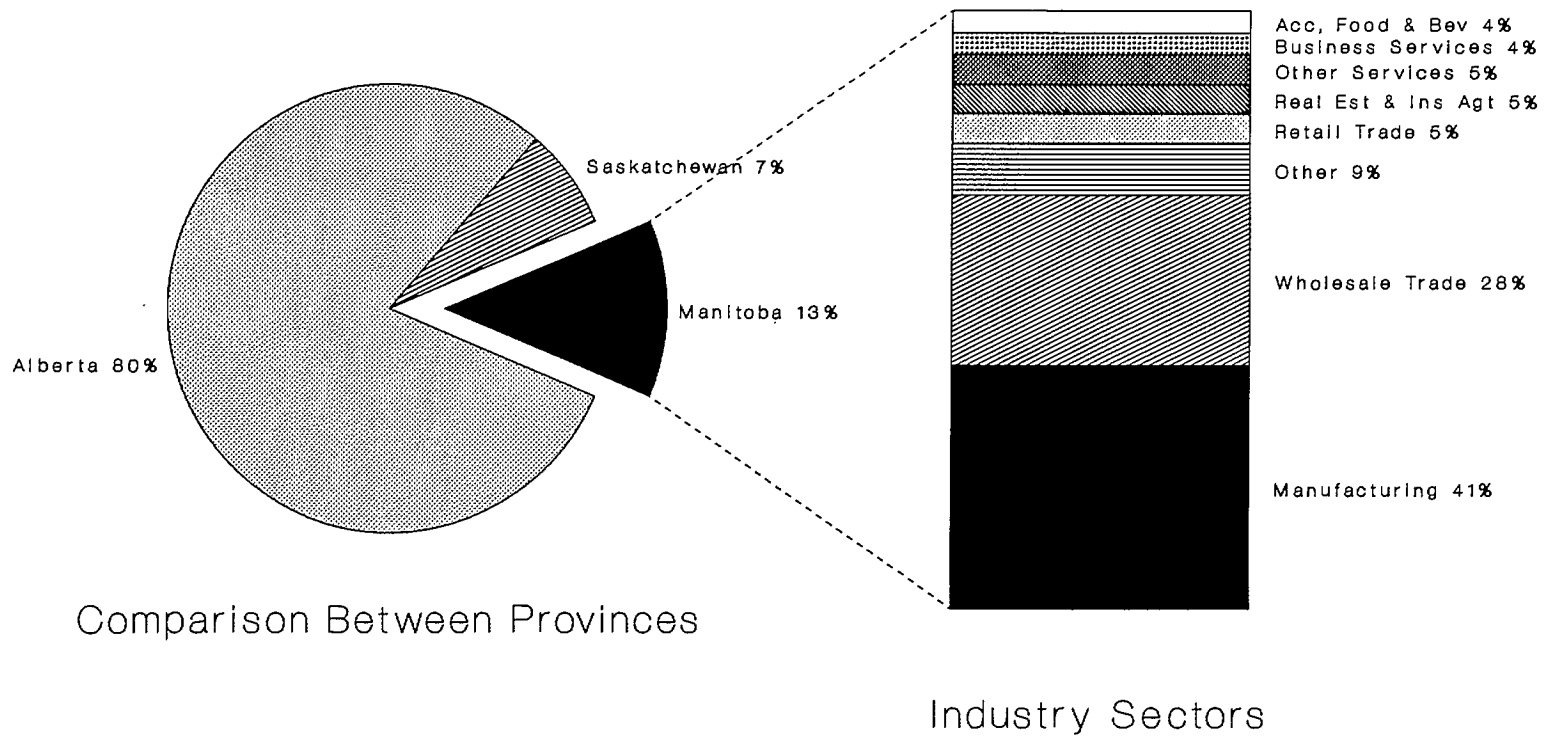

includes direct, indirect and incidental investment

# WORLD - MANITOBA 1985-1990 OVERVIEW TOTAL ASSETS

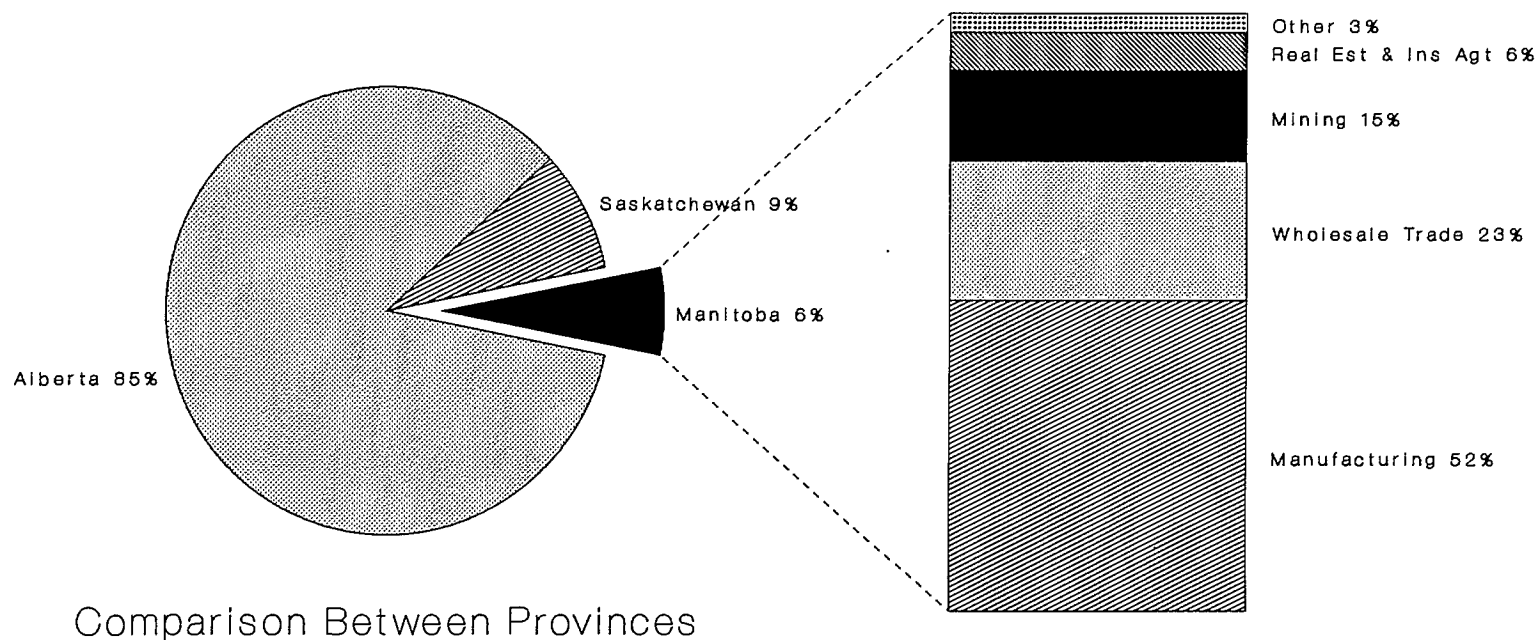

direct investment only

# WORLD - MANITOBA 1985-1990 OVERVIEW TOTAL FREQUENCIES

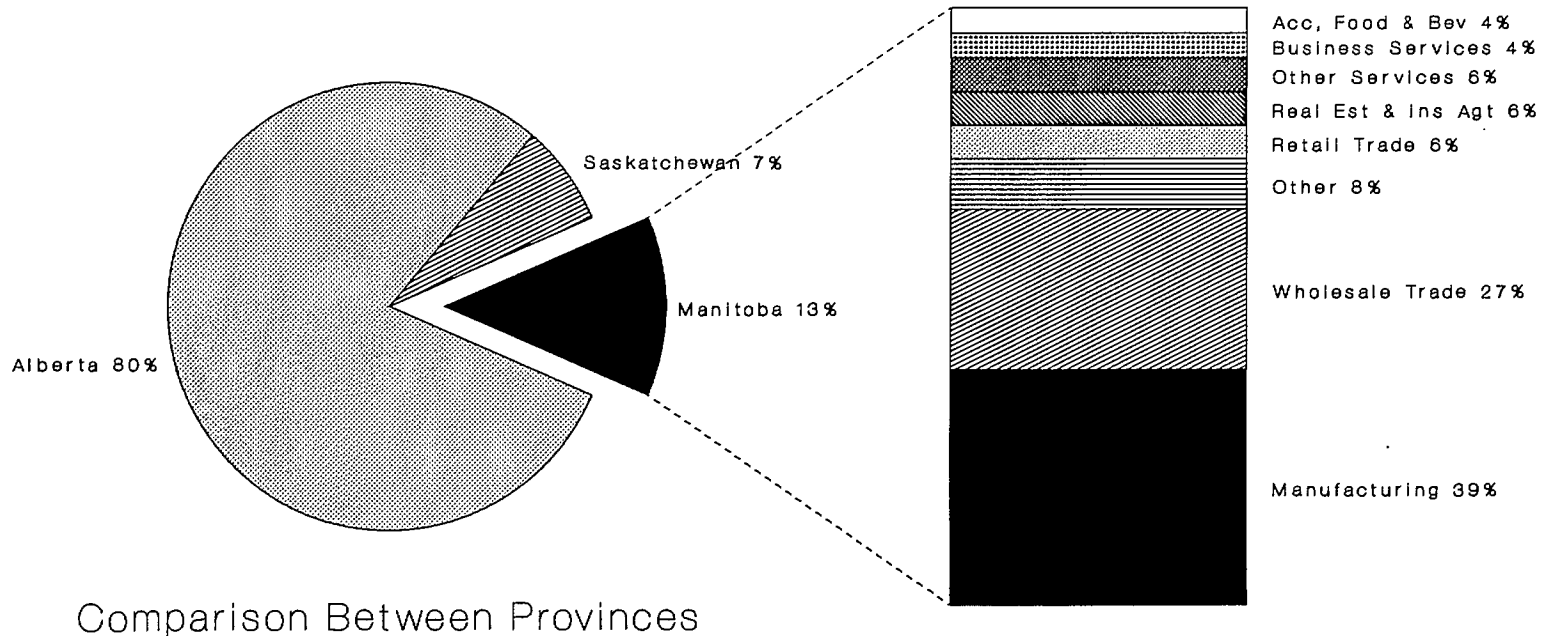

direct investment only

# WORLD - MANITOBA 1985-1990 INDUSTRY SECTORS TOTAL ASSETS

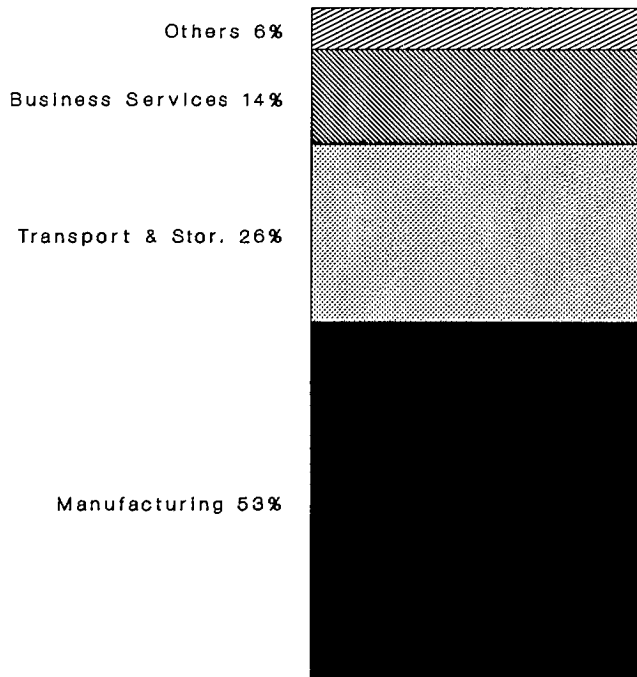

New Business

includes direct, indirect and incidental investment

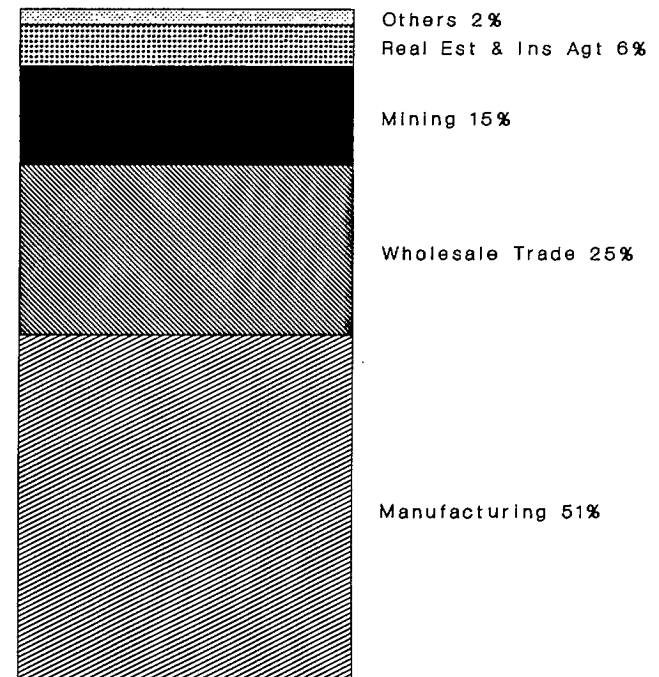

Acquisitions



# WORLD - MANITOBA 1985-1990

## INDUSTRY SECTORS

### TOTAL FREQUENCIES

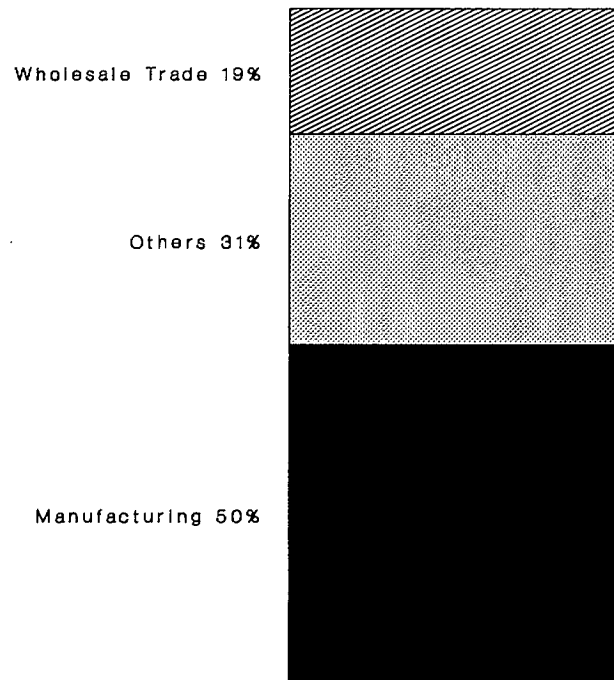

New Business

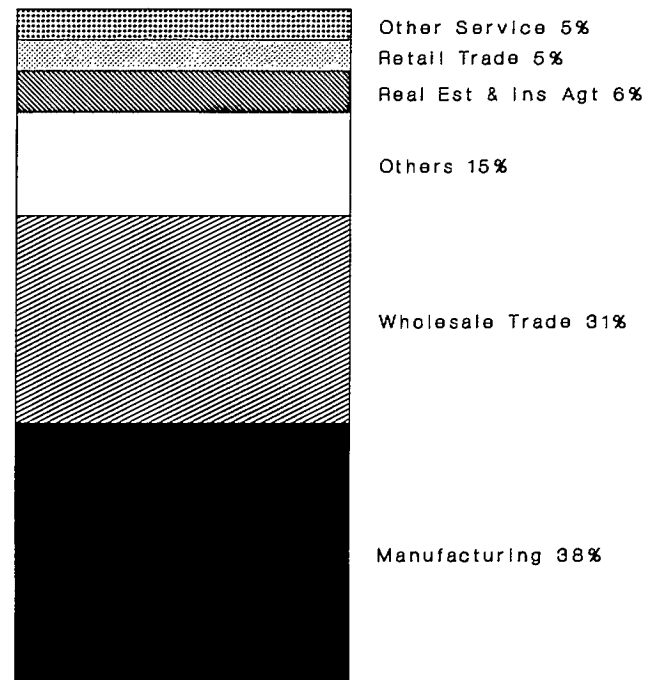

Acquisitions

**includes direct, indirect and incidental investment**

# WORLD - MANITOBA 1985-1990

## INDUSTRY SECTORS

### TOTAL ASSETS

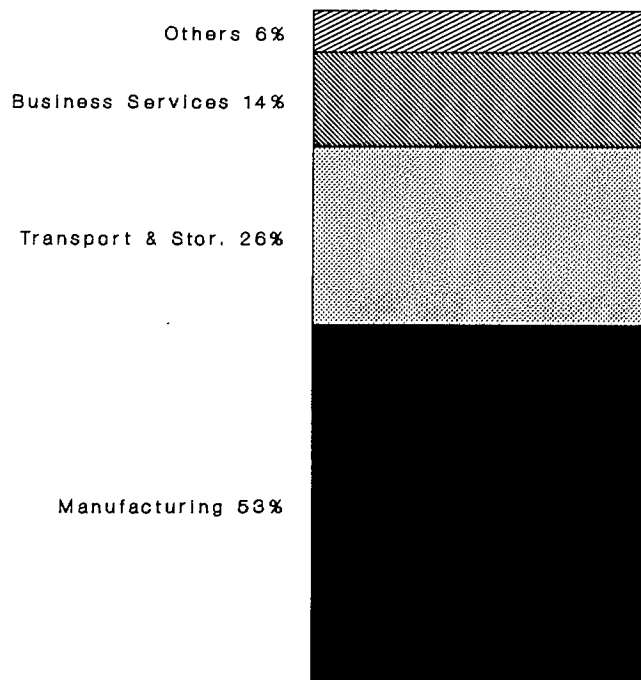

New Business

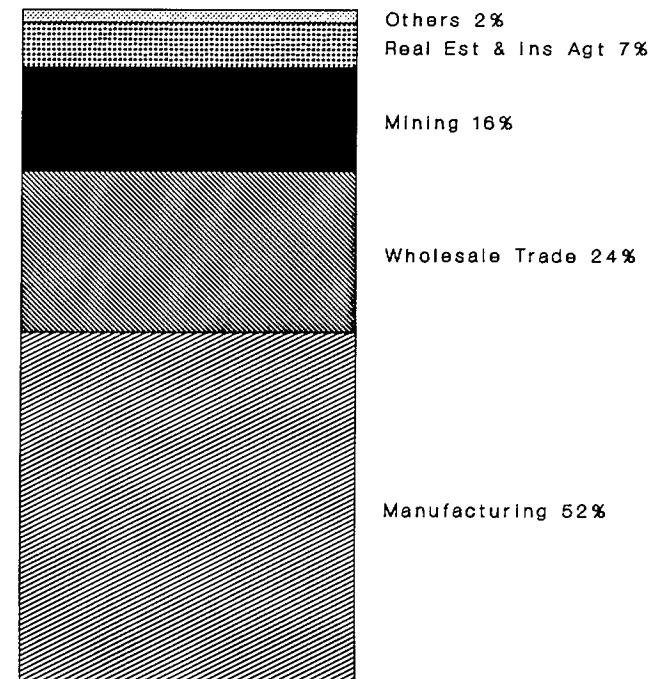

Acquisitions

direct investment only

# WORLD - MANITOBA 1985-1990

## INDUSTRY SECTORS

### TOTAL FREQUENCIES

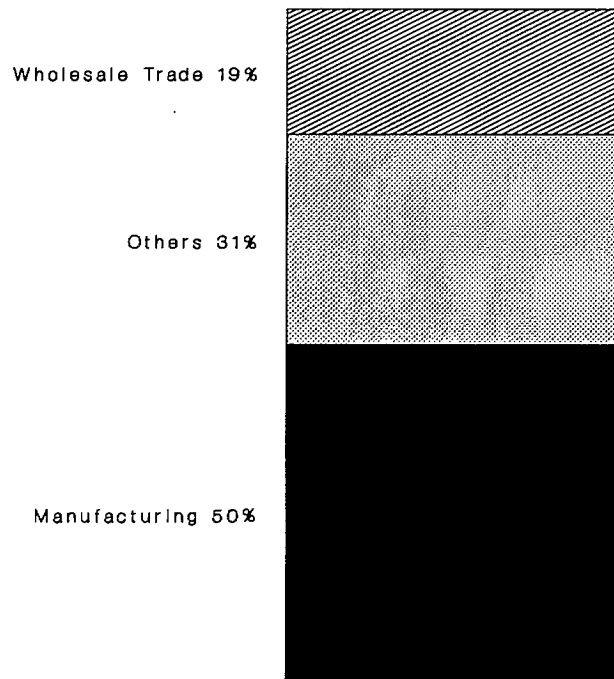

New Business

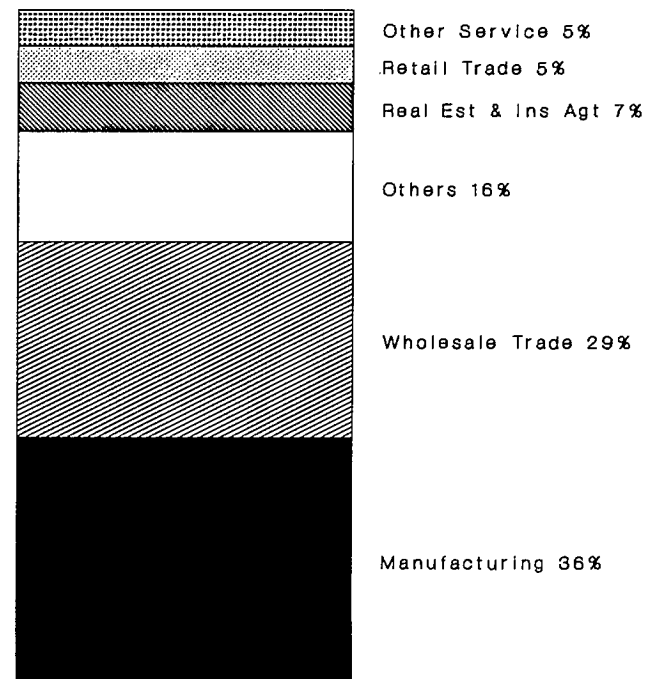

Acquisitions

direct investment only

# WORLD - SASKATCHEWAN 1985-1990 OVERVIEW TOTAL ASSETS

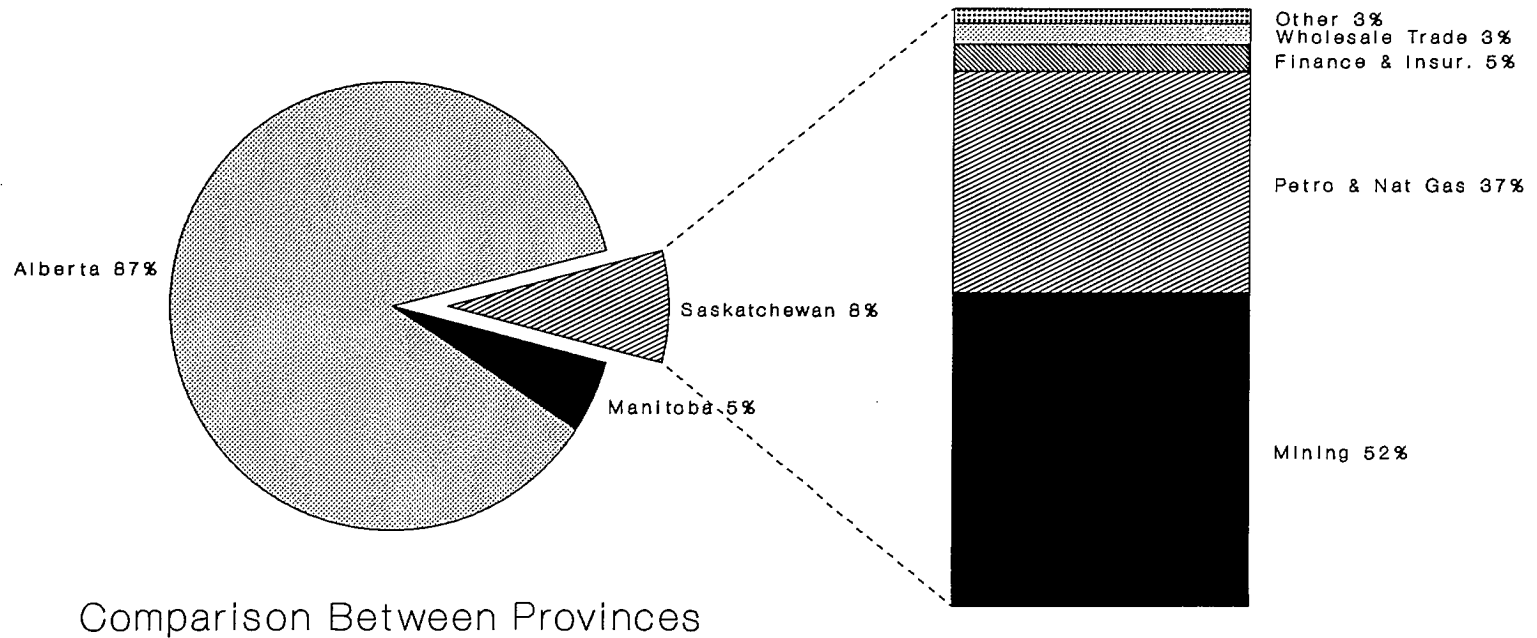

includes direct, indirect and incidental investment

# WORLD - SASKATCHEWAN 1985-1990 OVERVIEW TOTAL ASSETS

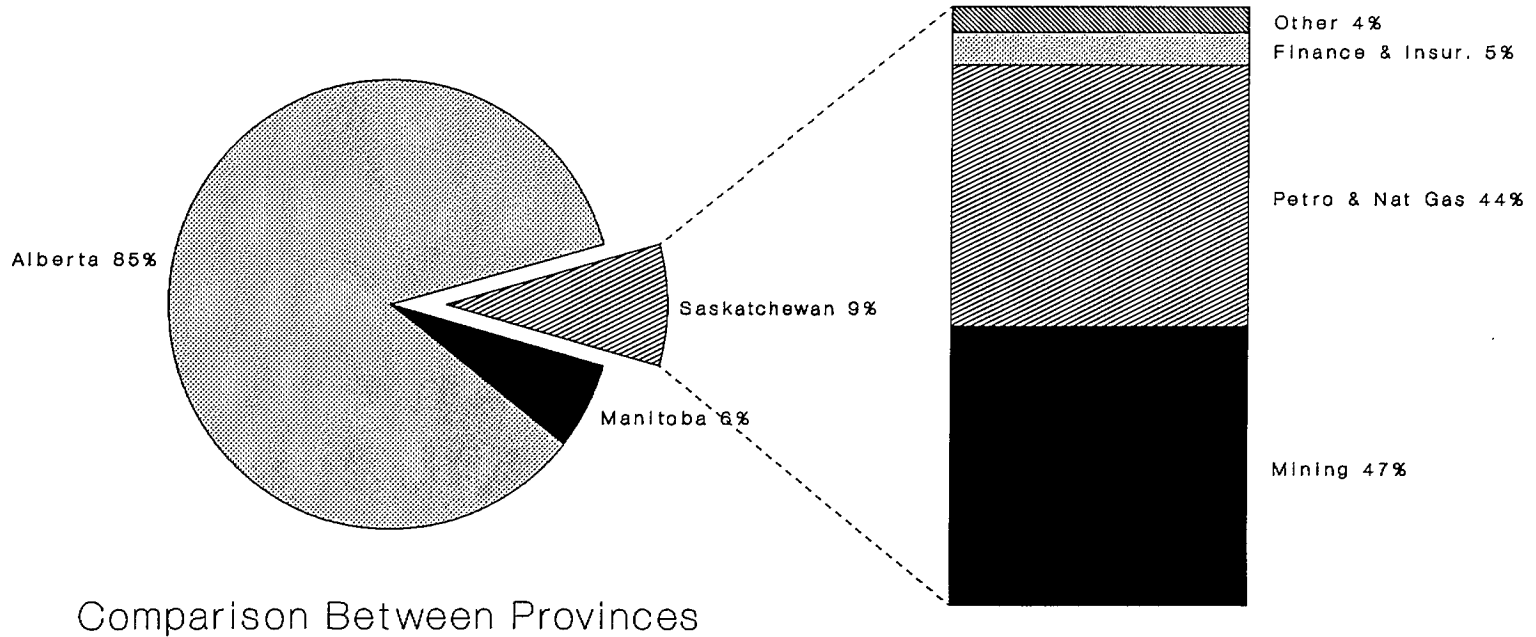

direct investment only

# WORLD - SASKATCHEWAN 1985-1990 OVERVIEW TOTAL FREQUENCIES

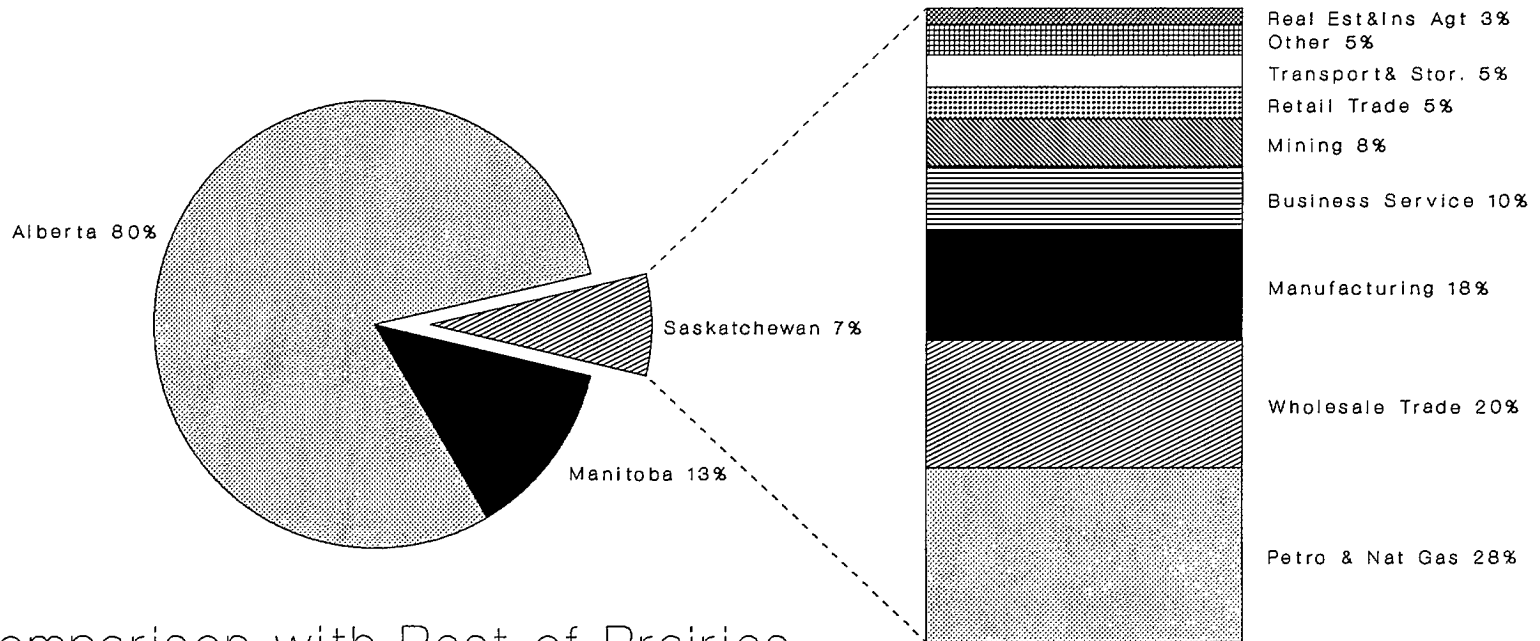

Comparison with Rest of Prairies

Industrial Sectors

direct investment only

# WORLD - SASKATCHEWAN 1985-1990

## INDUSTRY SECTORS

### TOTAL ASSETS

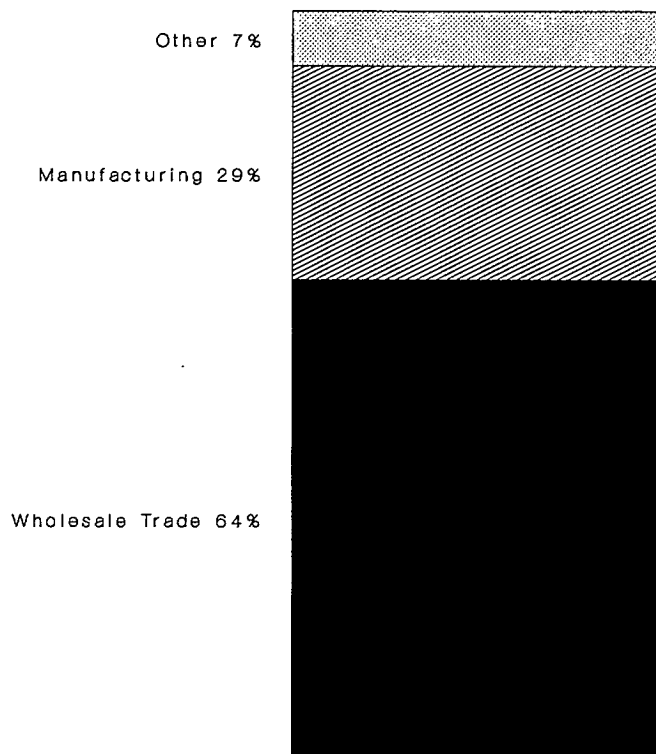

**New Business**  
 includes direct, indirect and incidental investment

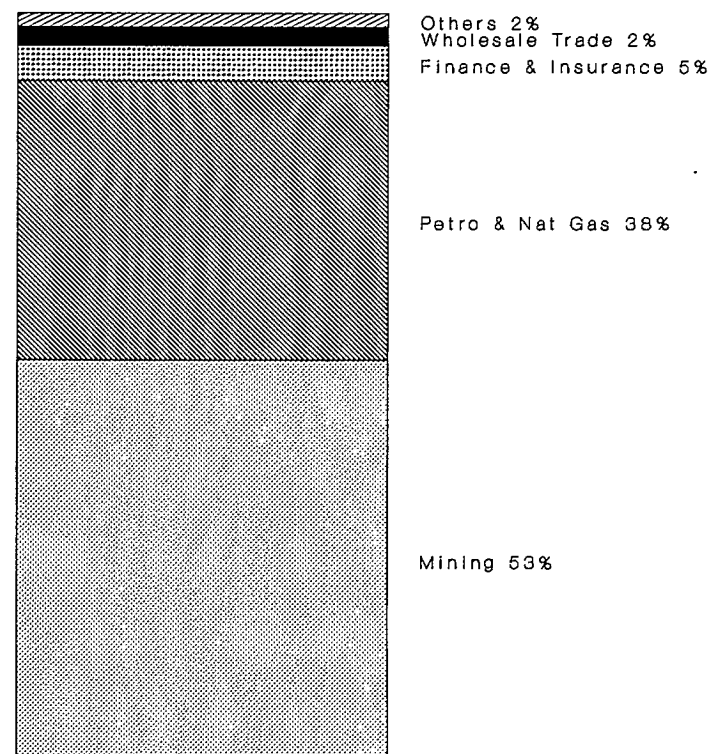

**Acquisitions**

# WORLD - SASKATCHEWAN 1985-1990

## INDUSTRY SECTORS

### TOTAL ASSETS

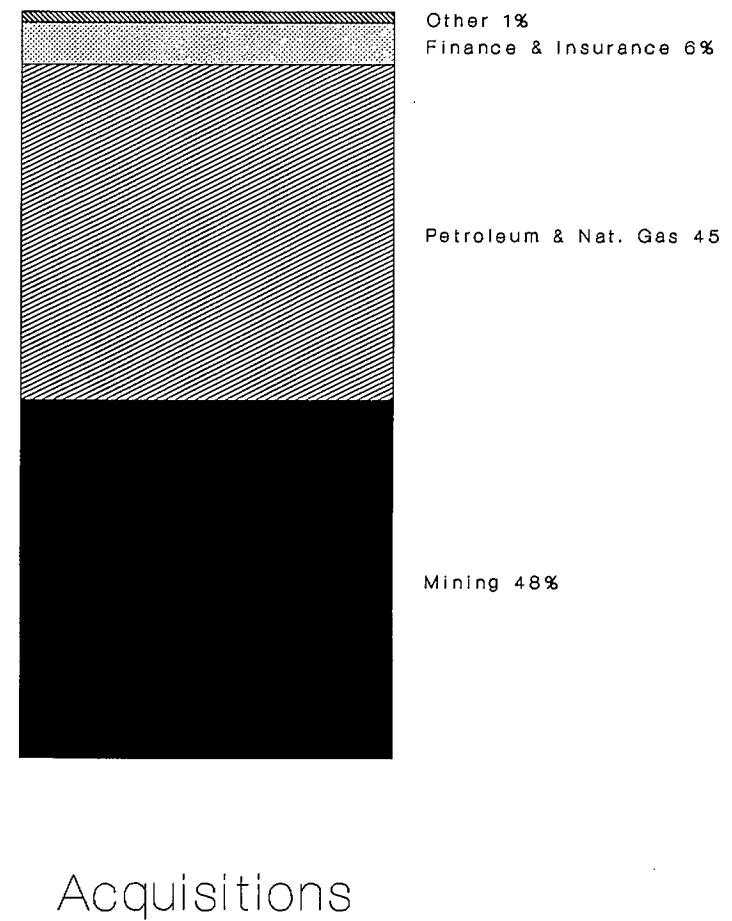
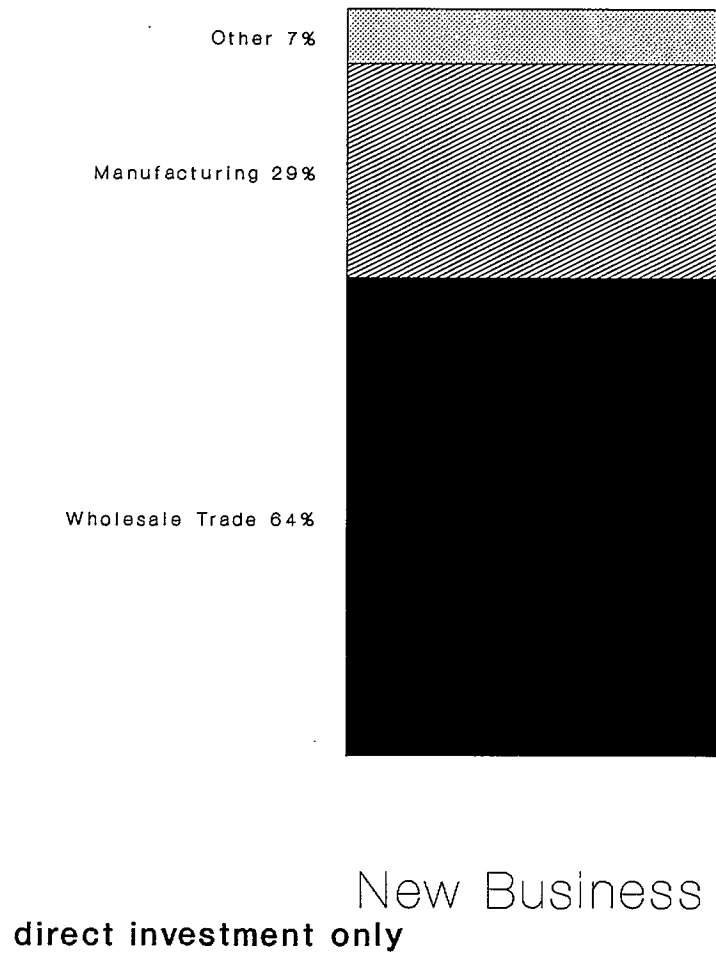



# WORLD - SASKATCHEWAN 1985-1990

## INDUSTRY SECTORS

### TOTAL FREQUENCIES

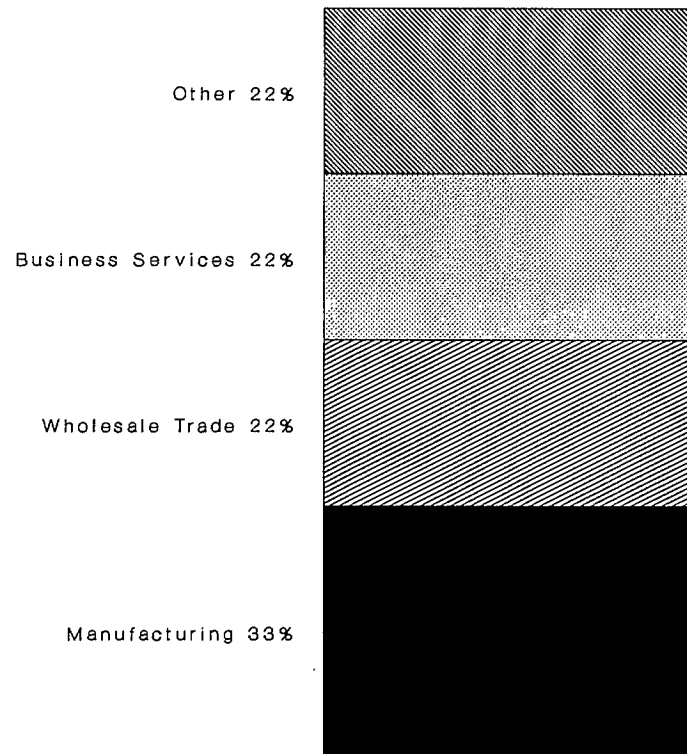

**New Business**  
 includes direct, indirect and incidental investment

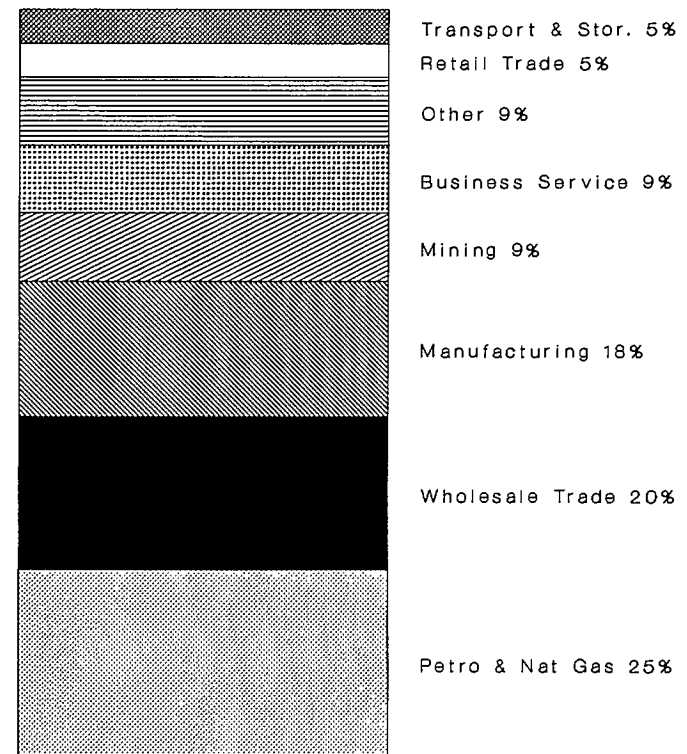

**Acquisitions**

# WORLD - SASKATCHEWAN 1985-1990

## INDUSTRY SECTORS

### TOTAL FREQUENCIES

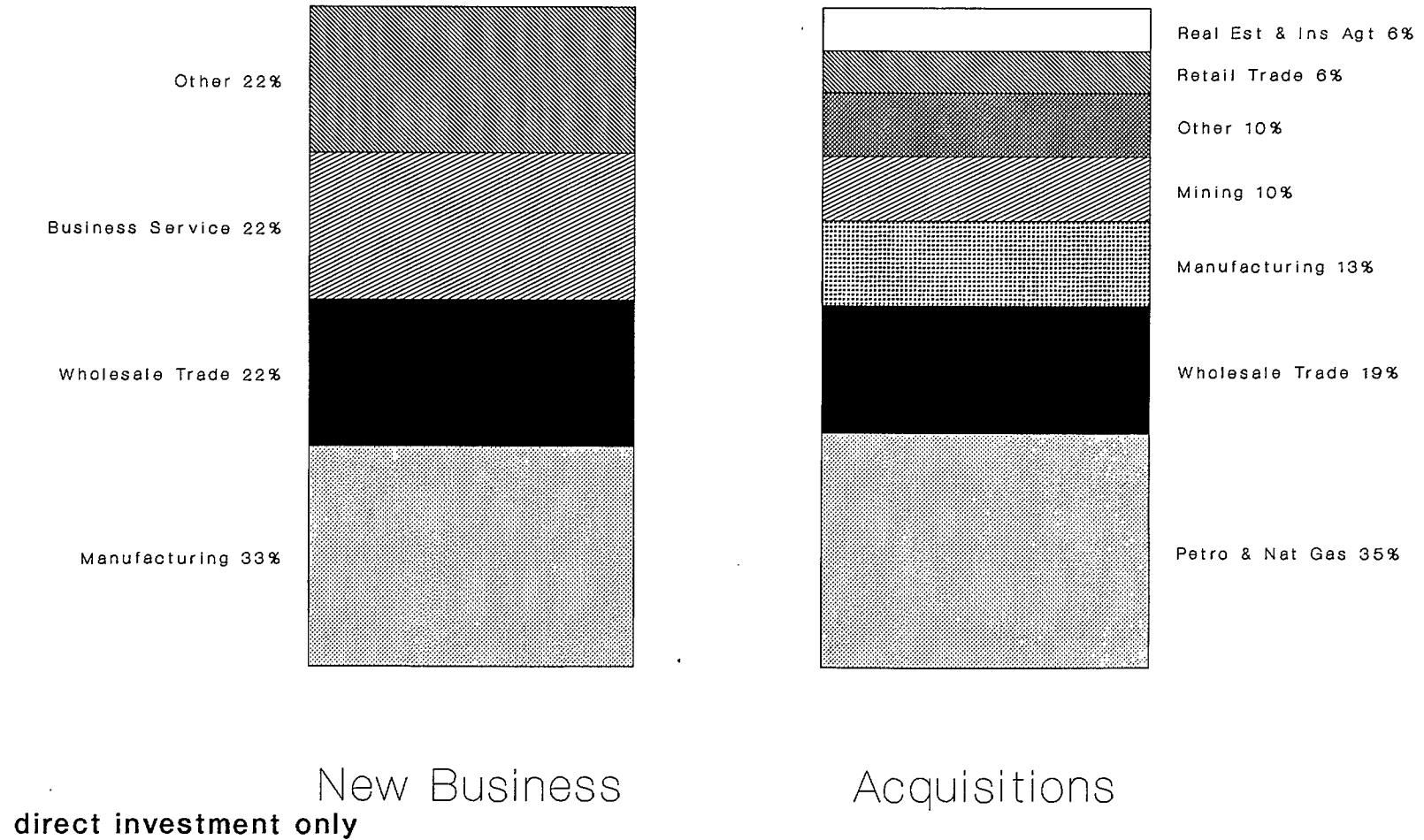

# WORLD - ALBERTA 1985-1990 OVERVIEW TOTAL ASSETS

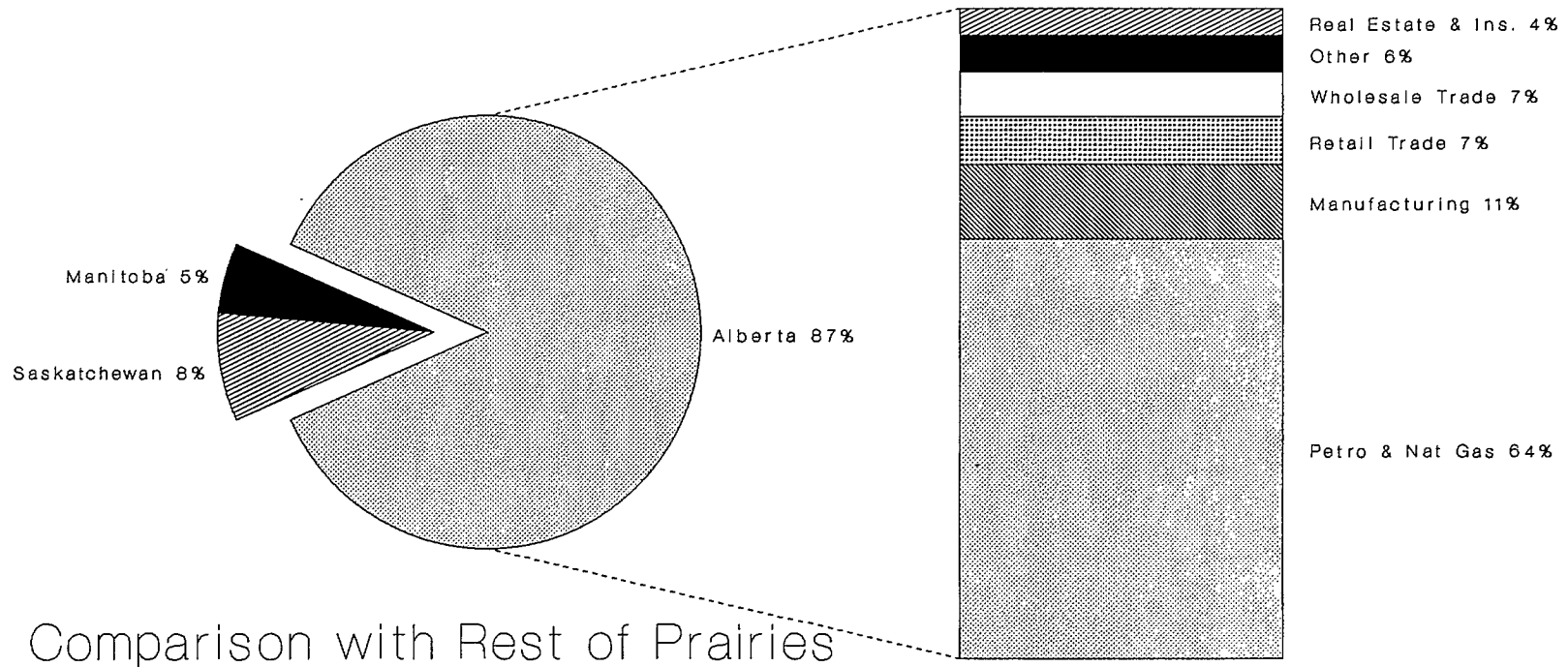

Industrial Sectors

includes direct, indirect and incidental investment

# WORLD - ALBERTA 1985-1990 OVERVIEW TOTAL ASSETS

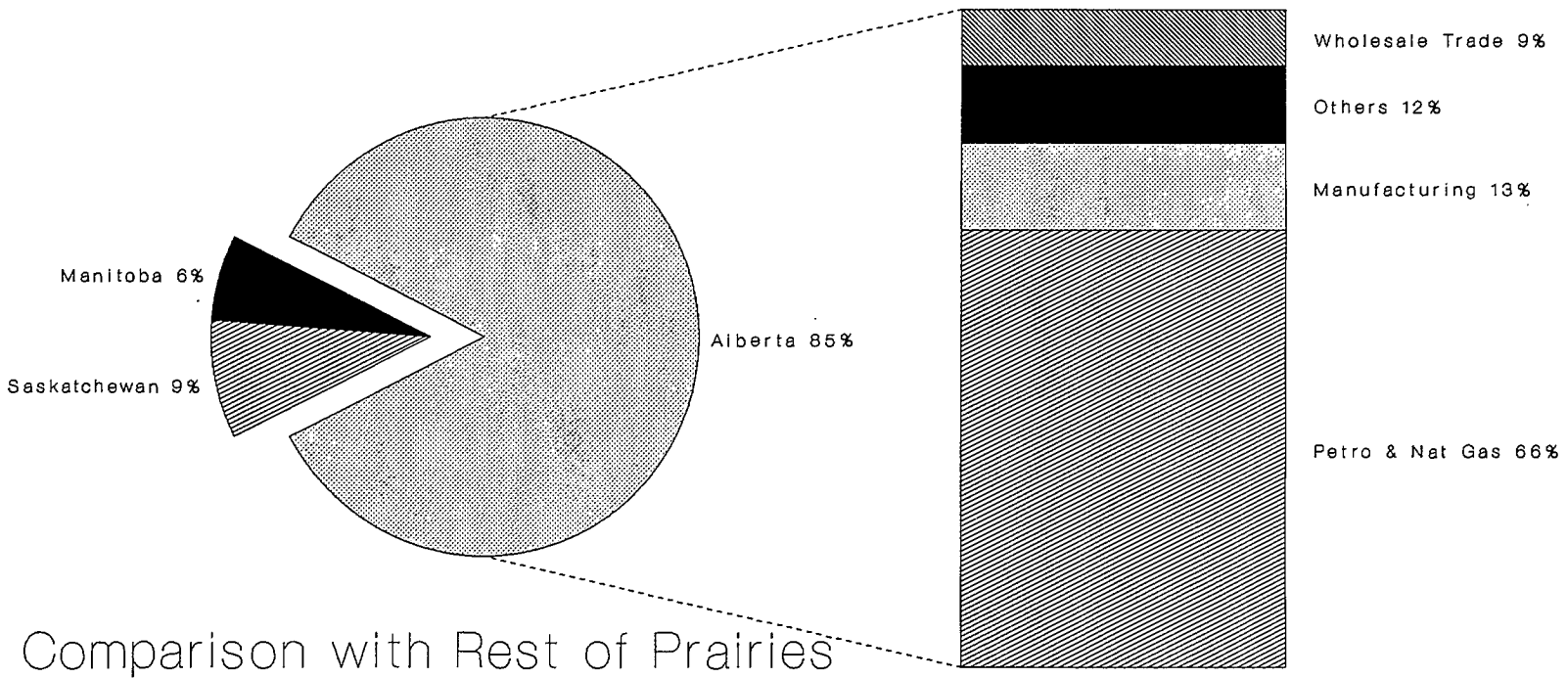

Industrial Sectors

direct investment only

# WORLD - ALBERTA 1985-1990 OVERVIEW TOTAL FREQUENCIES

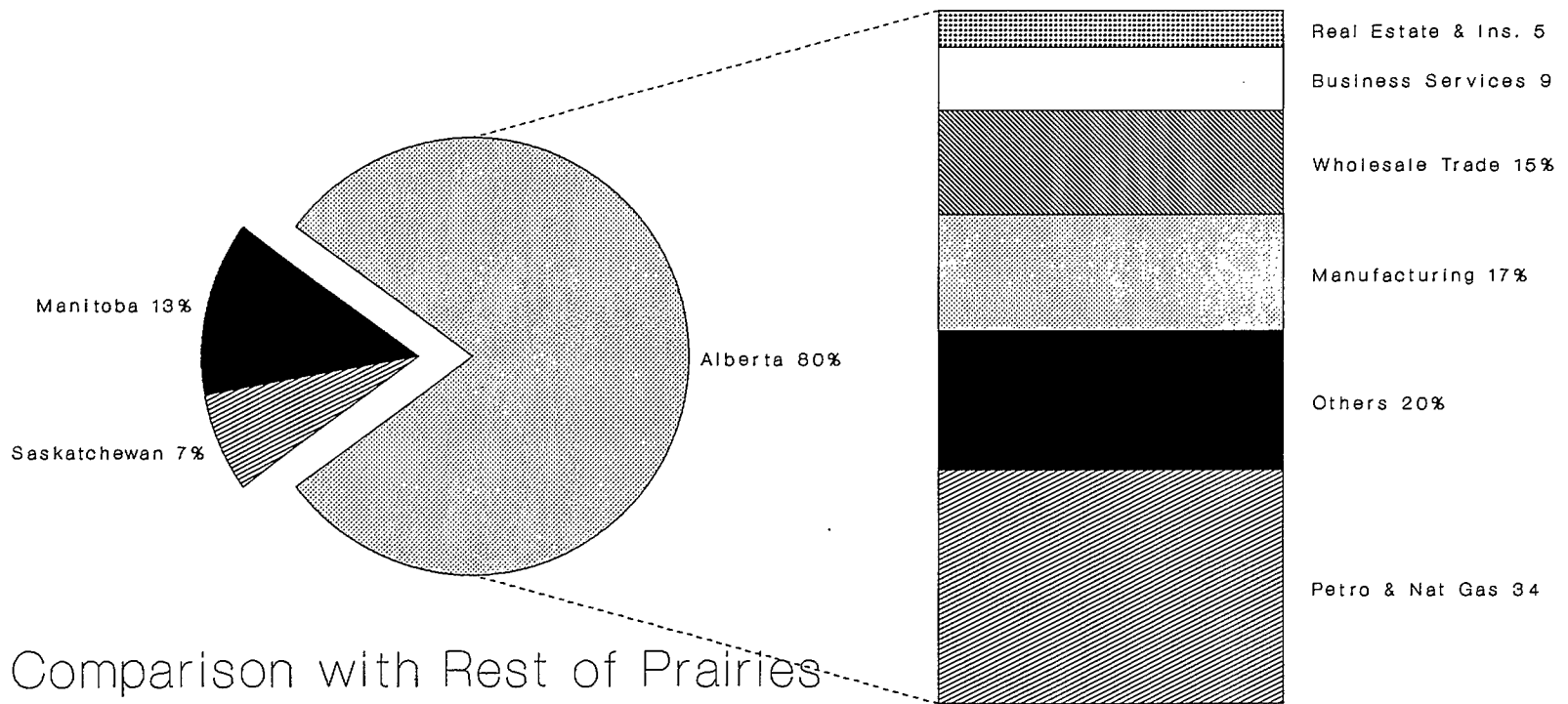

Industrial Sectors

direct investment only

# WORLD - ALBERTA 1985-1990 OVERVIEW TOTAL FREQUENCIES

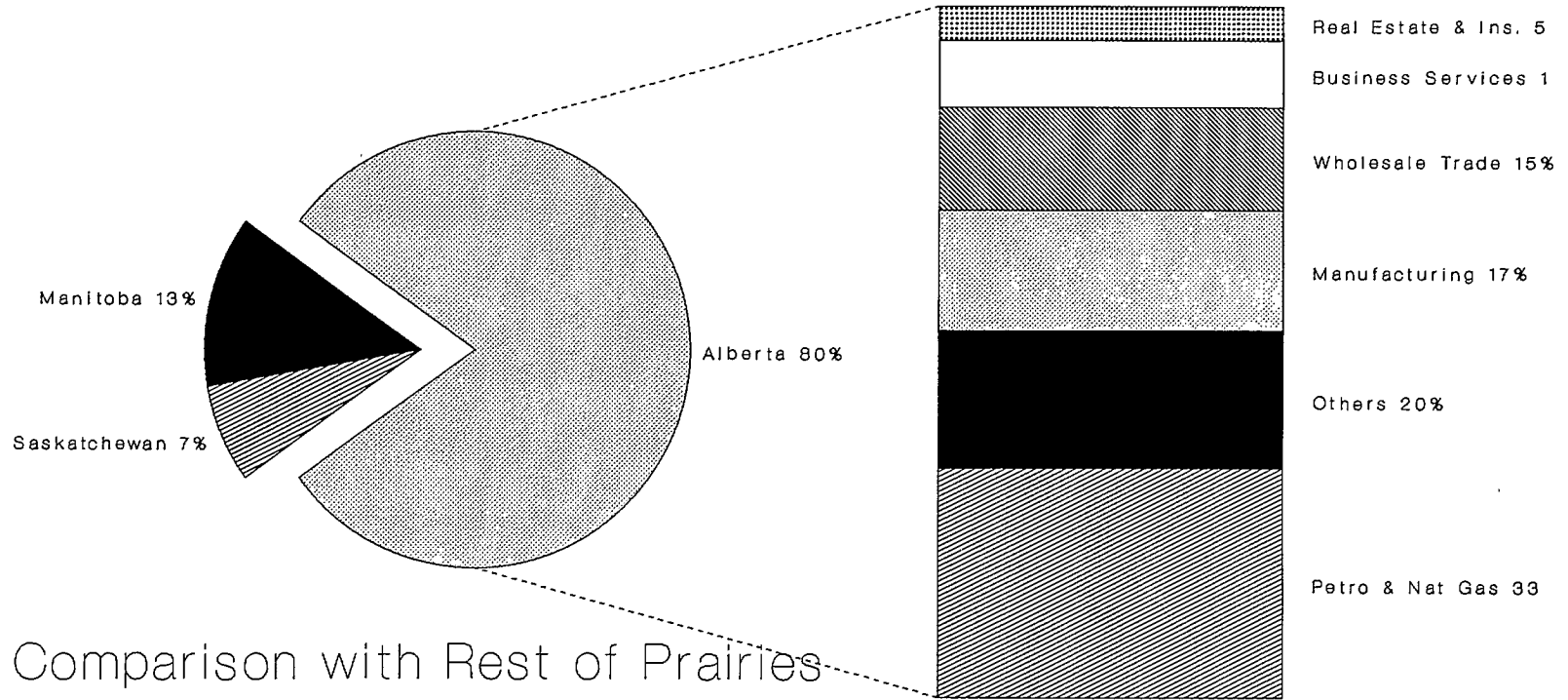

Industrial Sectors

includes direct, indirect and incidental investment

# WORLD - ALBERTA 1985-1990

## INDUSTRY SECTORS

### TOTAL ASSETS

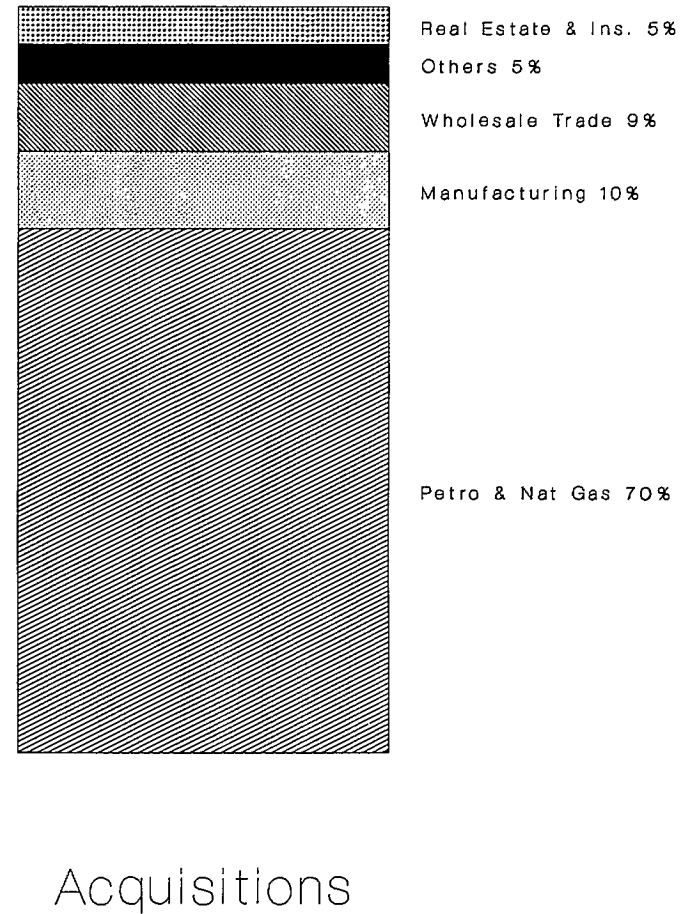
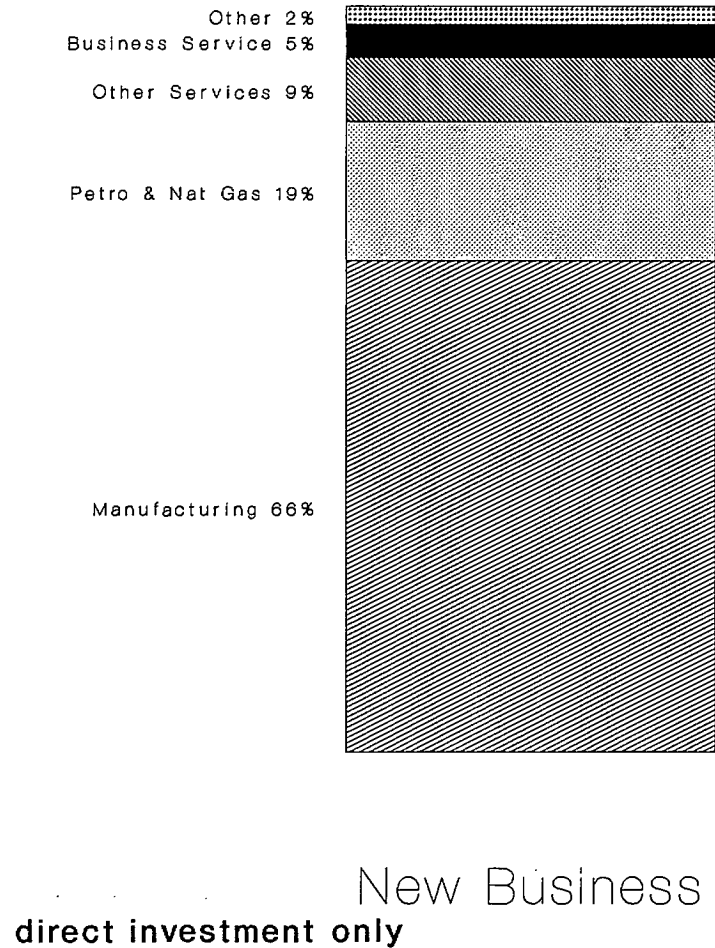

# WORLD - ALBERTA 1985-1990

## INDUSTRY SECTORS

### TOTAL FREQUENCIES

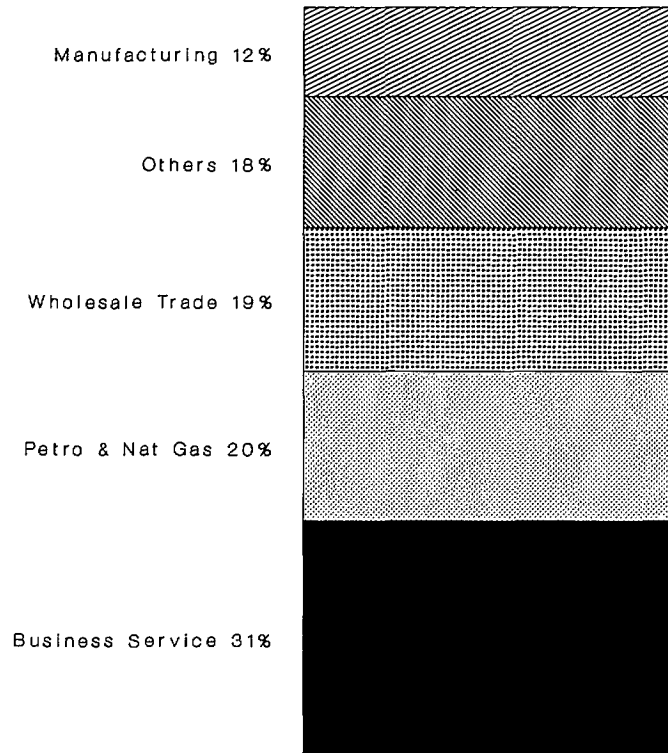

New Business  
direct investment only

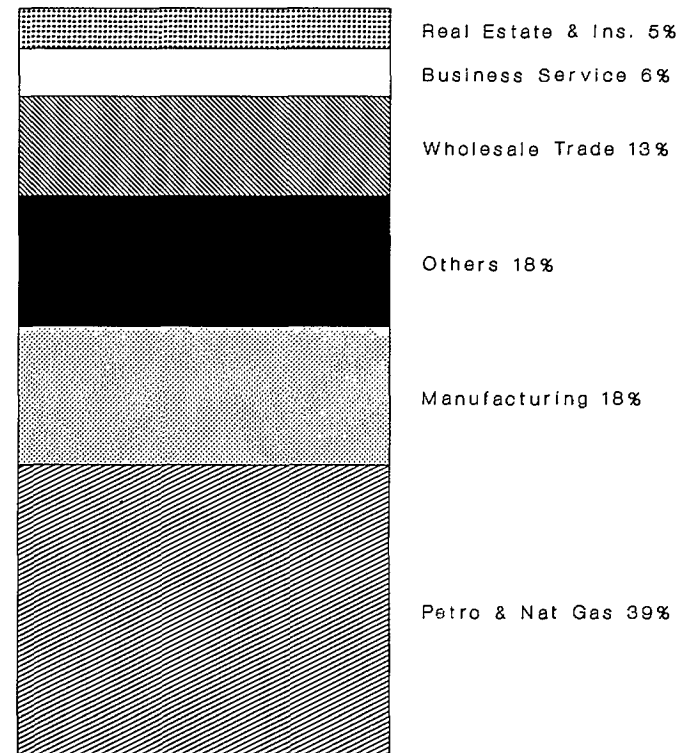

Acquisitions



# WORLD - ALBERTA 1985-1990

## INDUSTRY SECTORS

### TOTAL FREQUENCIES

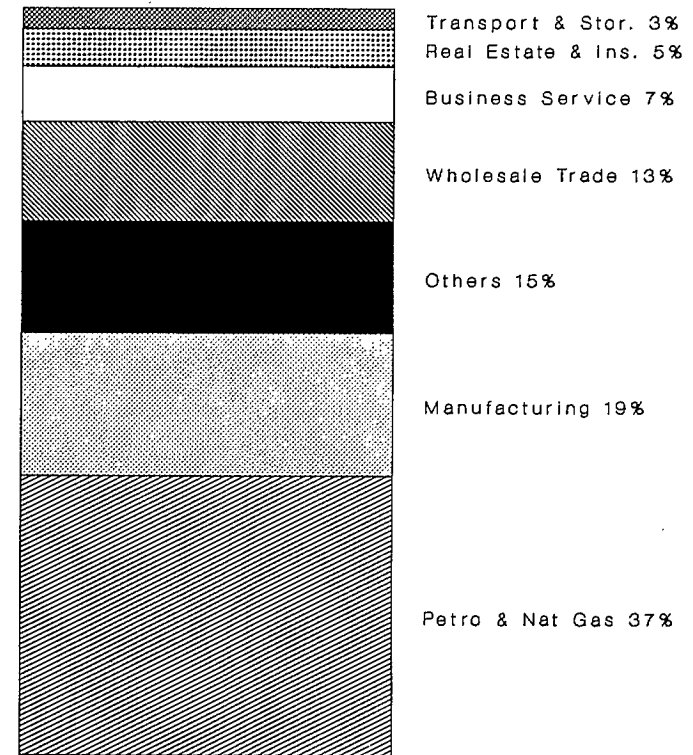
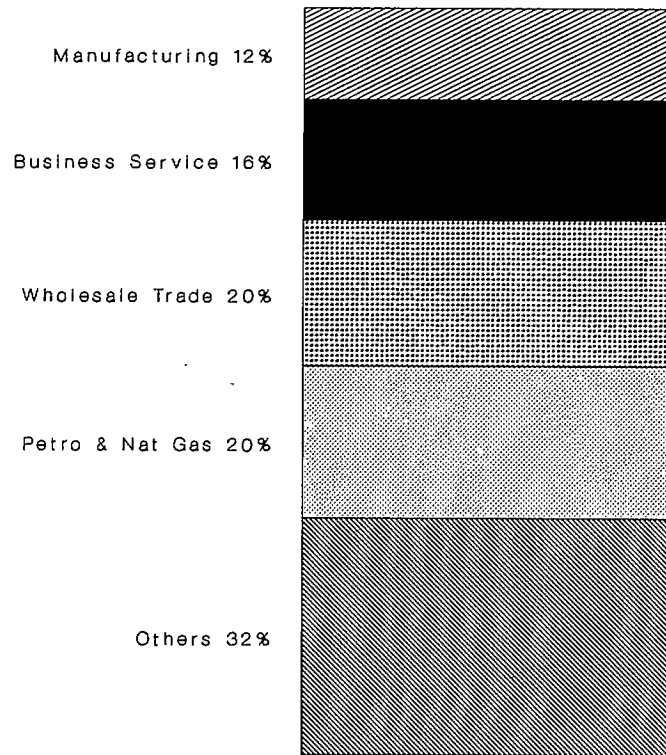

**New Business**  
 includes direct, indirect and incidental investment

Acquisitions

# **WORLD - BRITISH COLUMBIA - AN OVERVIEW**

## **OVERVIEW**

British Columbia is the destination of 8% of the asset value and 12% of the frequency of foreign investment.

## **TYPES OF INVESTMENT**

85% of the asset value and 94% of the frequency of investment is direct. New business accounts for 7% of the asset value and 31% of the frequency of direct investment.

## **INDUSTRY SECTORS**

Manufacturing is the preferred sector with 39% of the total asset value and 20% of the total frequency of investment transactions. Wholesale trade (18%), real estate and insurance agents (13%), and accommodation, food and beverage (12%) also draw a significant portion of the asset value of investment. These industries, wholesale trade (16%), real estate and insurance agents (15%), and accommodation, food and beverage (10%), are also the most frequent targets after manufacturing.

# WORLD - BRITISH COLUMBIA 1985-1990 OVERVIEW TOTAL ASSETS

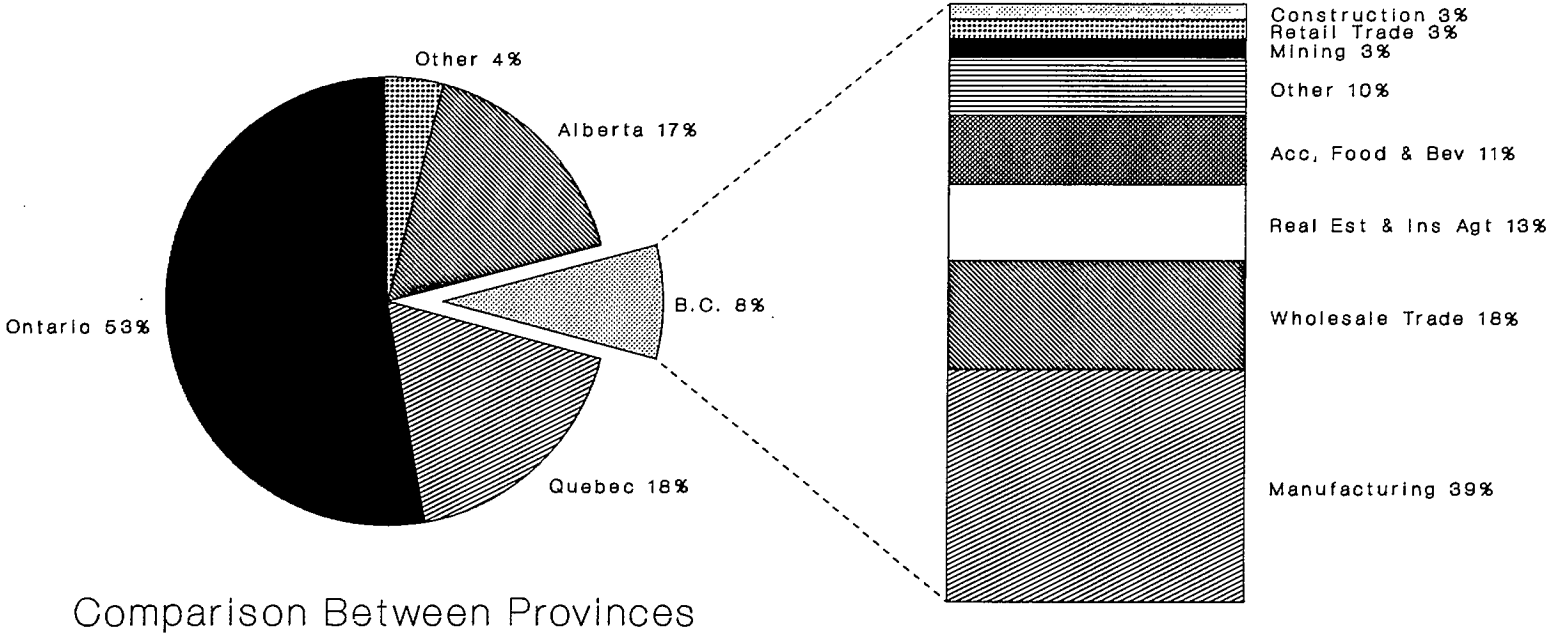

Comparison Between Provinces

Industry Sectors

includes direct, indirect and incidental investment

# WORLD - BRITISH COLUMBIA 1985-1990

## OVERVIEW

### TOTAL FREQUENCIES

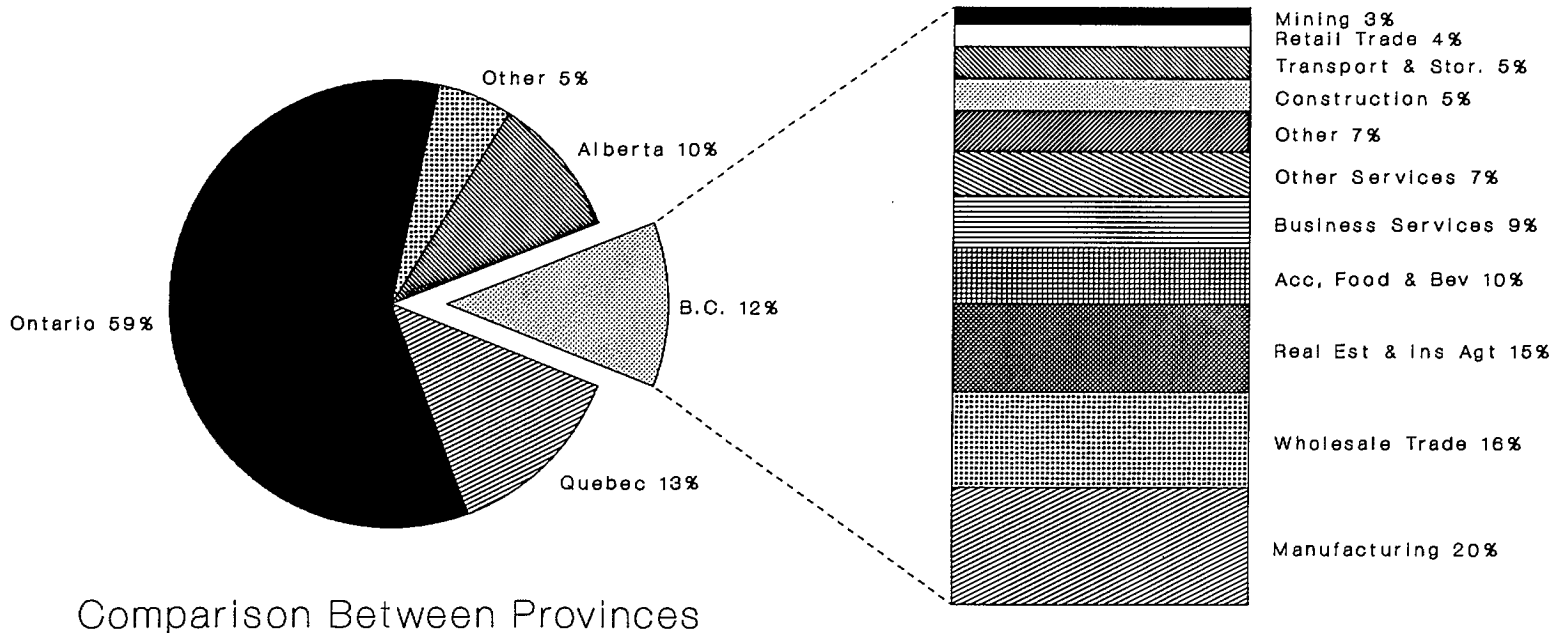

Comparison Between Provinces

Industry Sectors

includes direct, indirect and incidental investment

# WORLD - BRITISH COLUMBIA 1985-1990 OVERVIEW TOTAL ASSETS

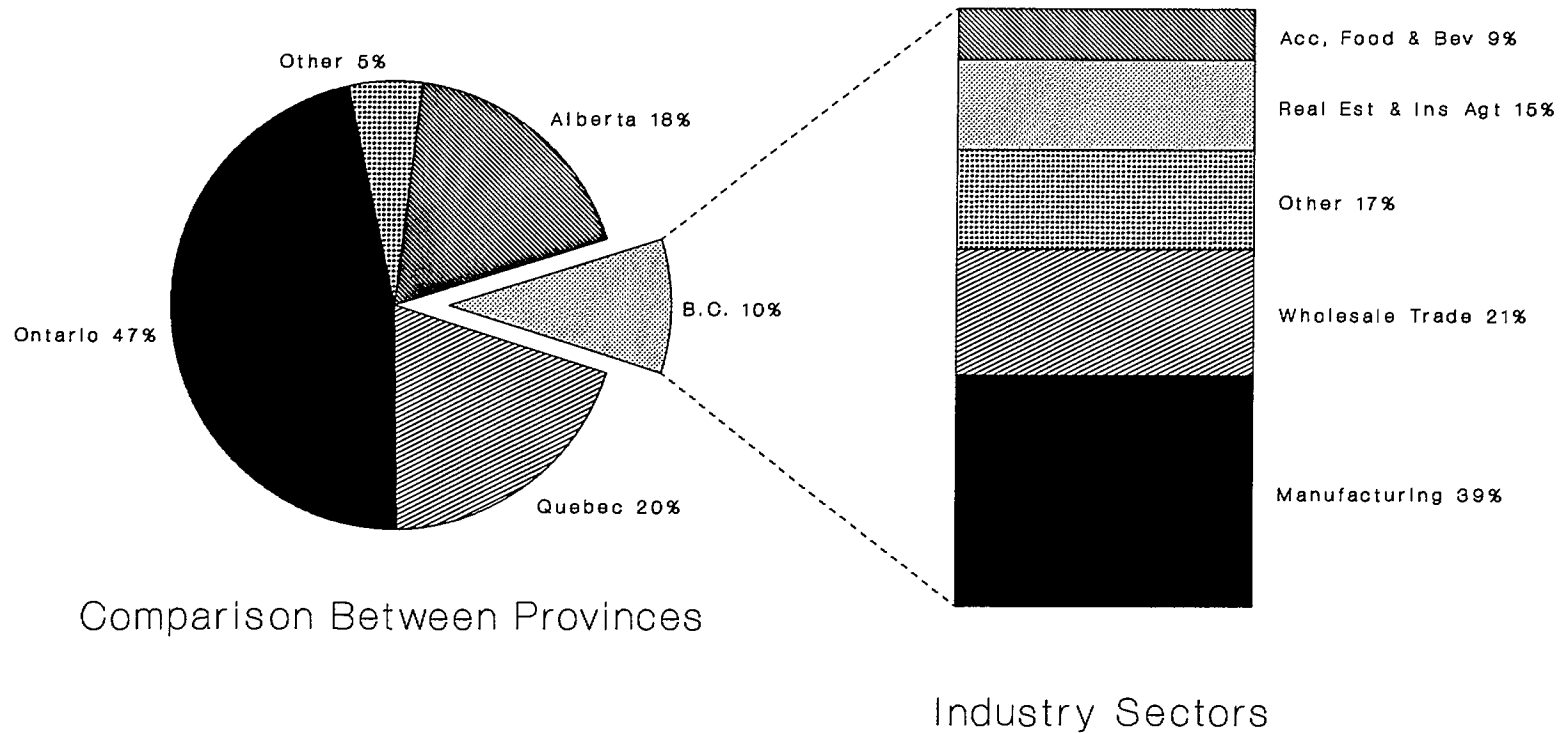

direct investment only

# WORLD - BRITISH COLUMBIA 1985-1990

## OVERVIEW

### TOTAL FREQUENCIES

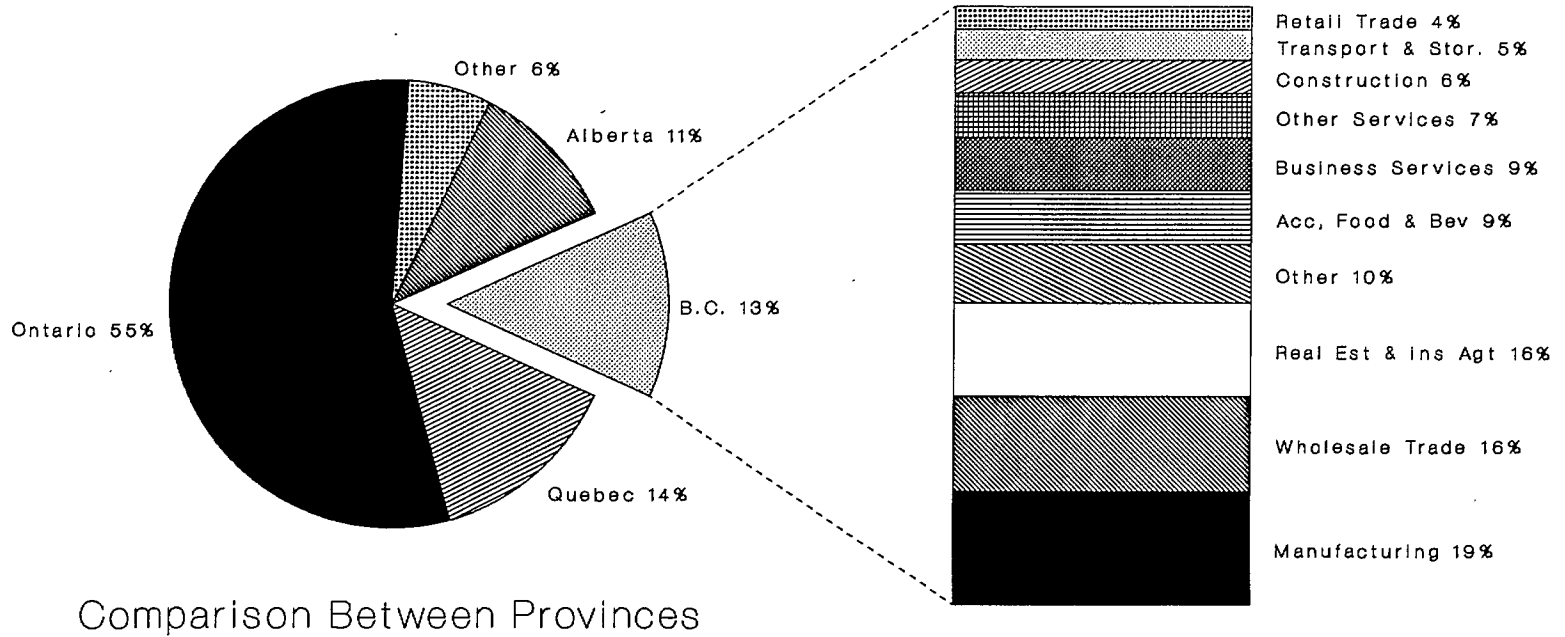

direct investment only

# WORLD - BRITISH COLUMBIA 1985-1990

## TYPES OF INVESTMENT

### TOTAL ASSETS

Acquisitions 94%

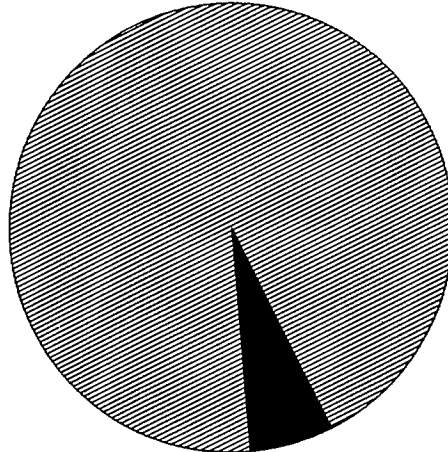

New Business 6%

Direct, Indirect and Incidental

Acquisitions 93%

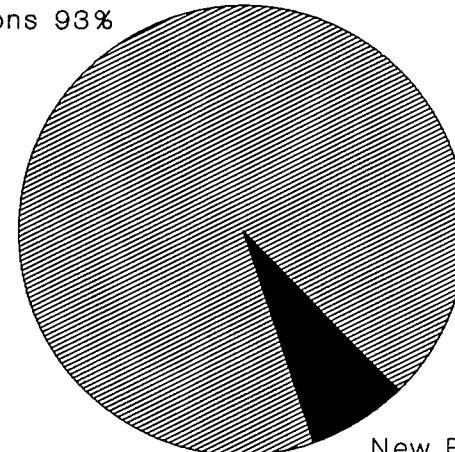

New Business 7%

Direct

**85% of the asset value of investment was direct**

# WORLD - BRITISH COLUMBIA 1985-1990

## TYPES OF INVESTMENT

### TOTAL FREQUENCIES

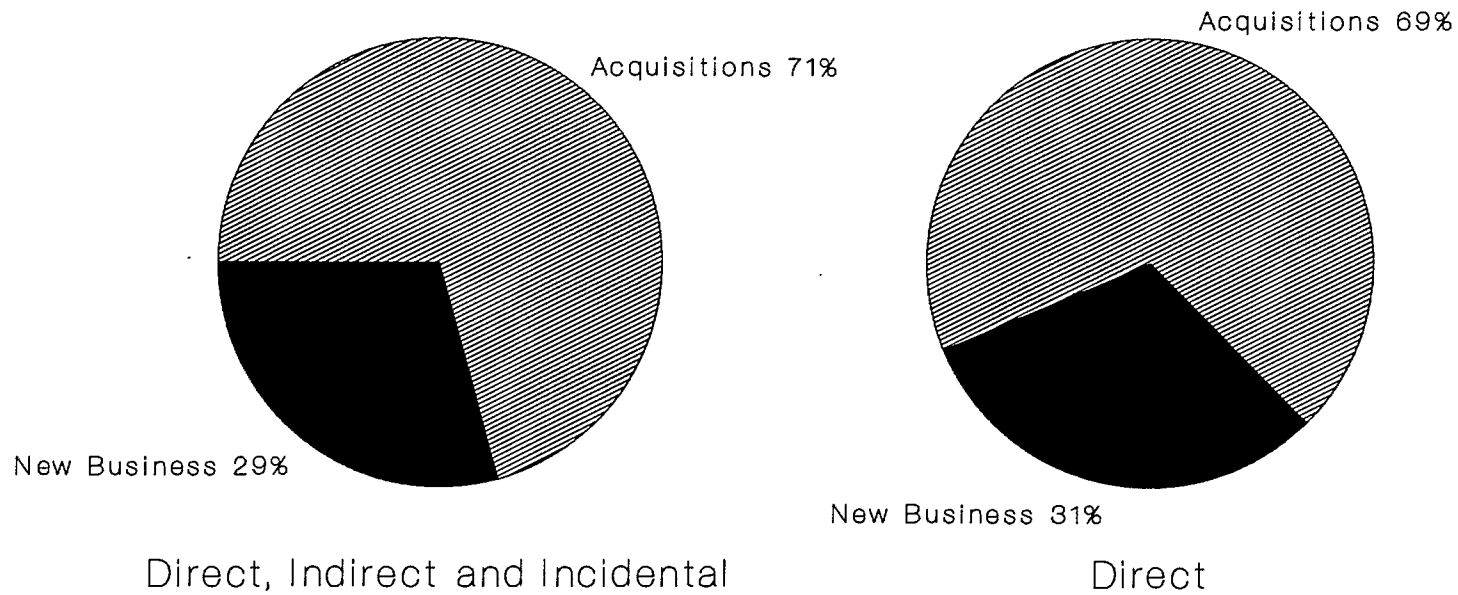

**94% of the total number of transactions were direct**



# WORLD - BRITISH COLUMBIA 1985-1990

## INDUSTRY SECTORS

### TOTAL ASSETS

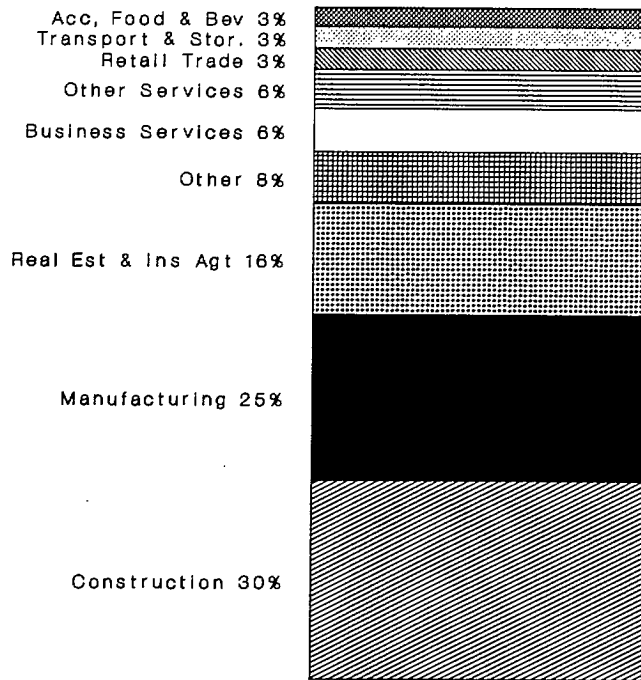

New Business

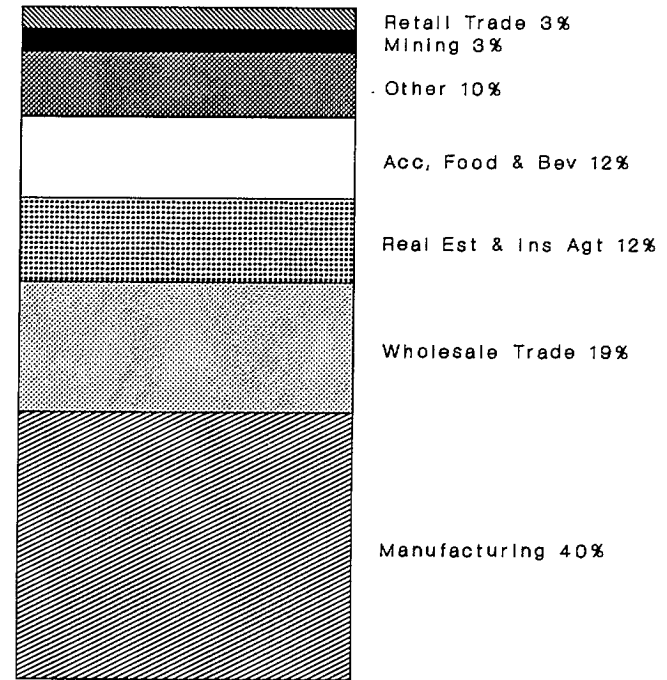

Acquisitions

**includes direct, indirect and incidental investment**

# WORLD - BRITISH COLUMBIA 1985-1990

## INDUSTRY SECTORS

### TOTAL FREQUENCIES

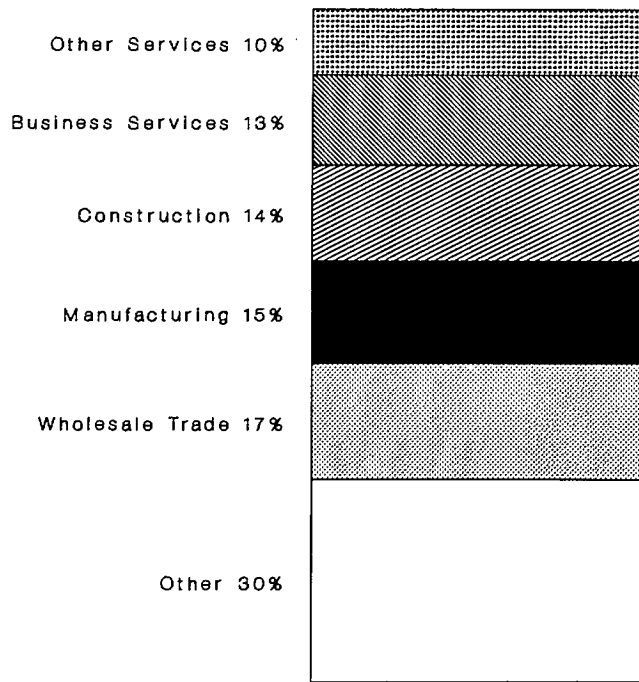

New Business

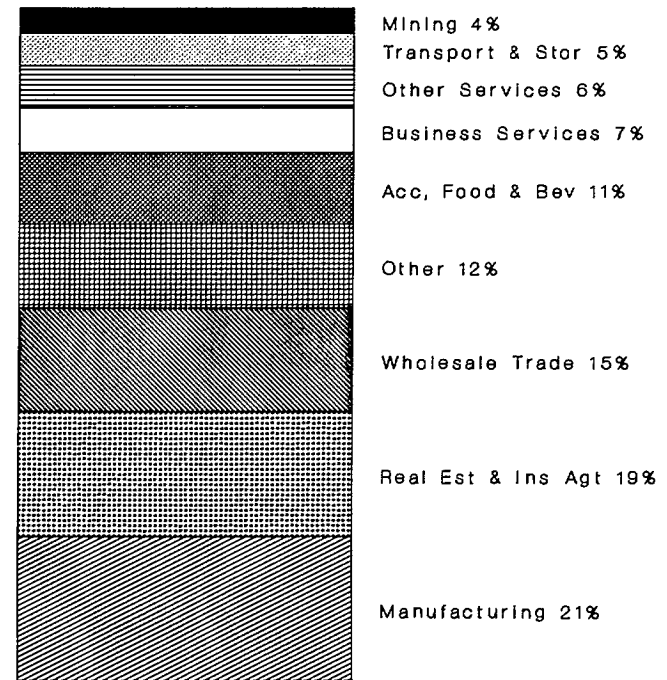

Acquisitions

includes direct, indirect and incidental investment

# WORLD - BRITISH COLUMBIA 1985-1990

## INDUSTRY SECTORS

### TOTAL ASSETS

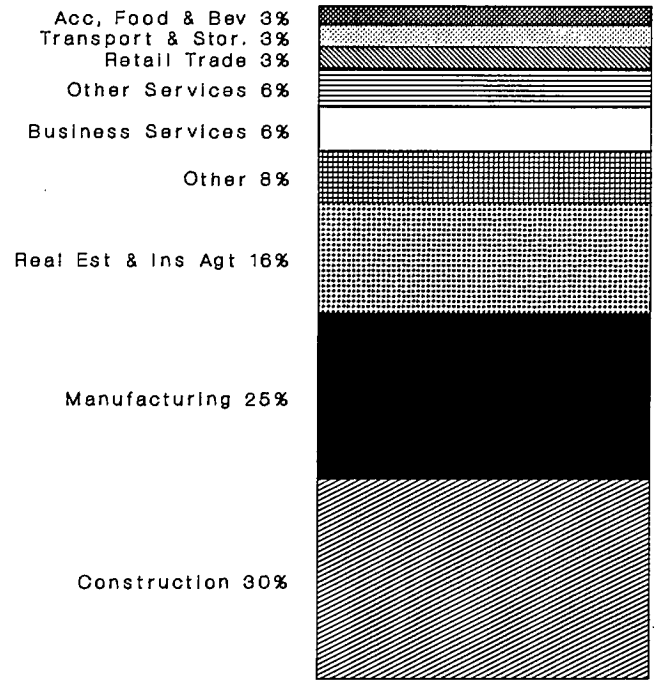

New Business

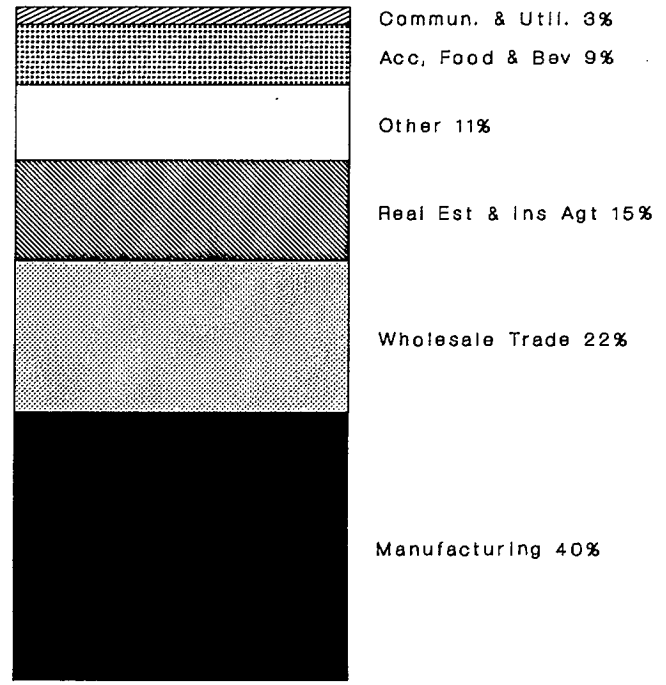

Acquisitions

direct investment only

# WORLD - BRITISH COLUMBIA 1985-1990

## INDUSTRY SECTORS

### TOTAL FREQUENCIES

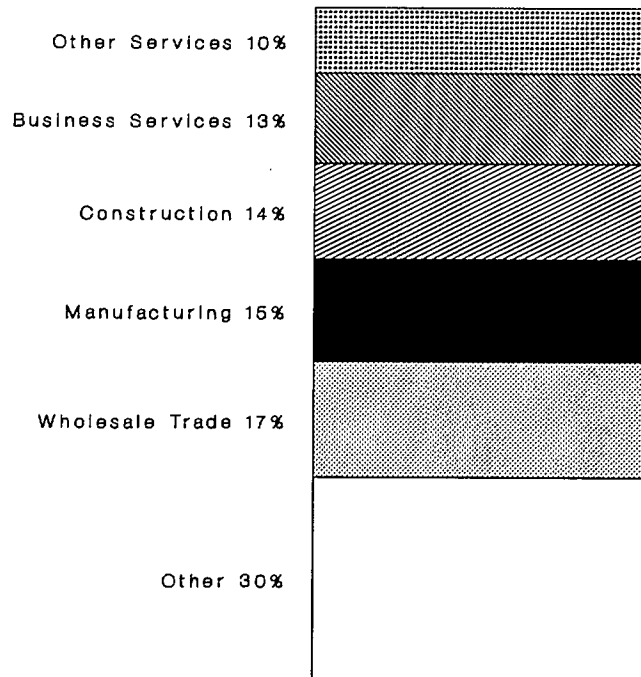

New Business

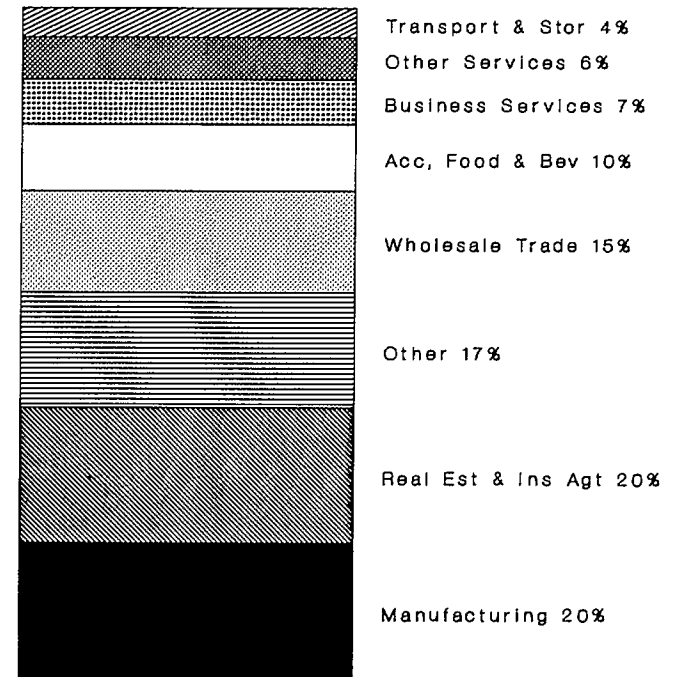

Acquisitions

direct investment only

## **WORLD - NORTH-WEST & YUKON TERRITORIES - AN OVERVIEW**

### **OVERVIEW**

A negligible portion of the asset value and frequency of foreign investment is made in the territories.

### **TYPES OF INVESTMENT**

97% of the asset and ten of the twelve transactions were direct. Three of these transactions were new business. They account for a negligible portion of the asset value of investment.

### **INDUSTRY SECTORS**

Mining is by far the preferred sector with 81% of the asset value and 58% of the frequency of total investment. Accommodation, food and beverage industries were also significant with 17% of both the total asset value and frequency of investment.

# WORLD - TERRITORIES 1985-1990 OVERVIEW TOTAL ASSETS

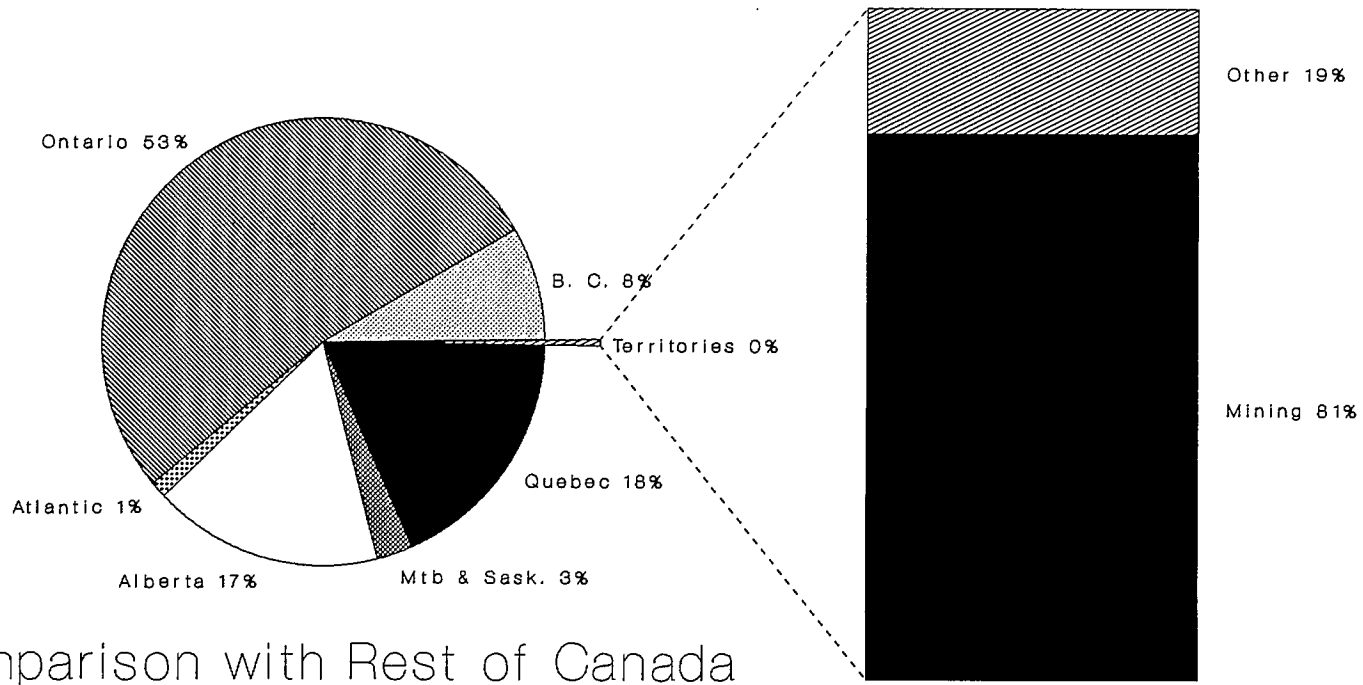

Comparison with Rest of Canada

Industrial Sectors

includes direct, indirect and incidental investment

# WORLD - TERRITORIES 1985-1990 OVERVIEW TOTAL FREQUENCIES

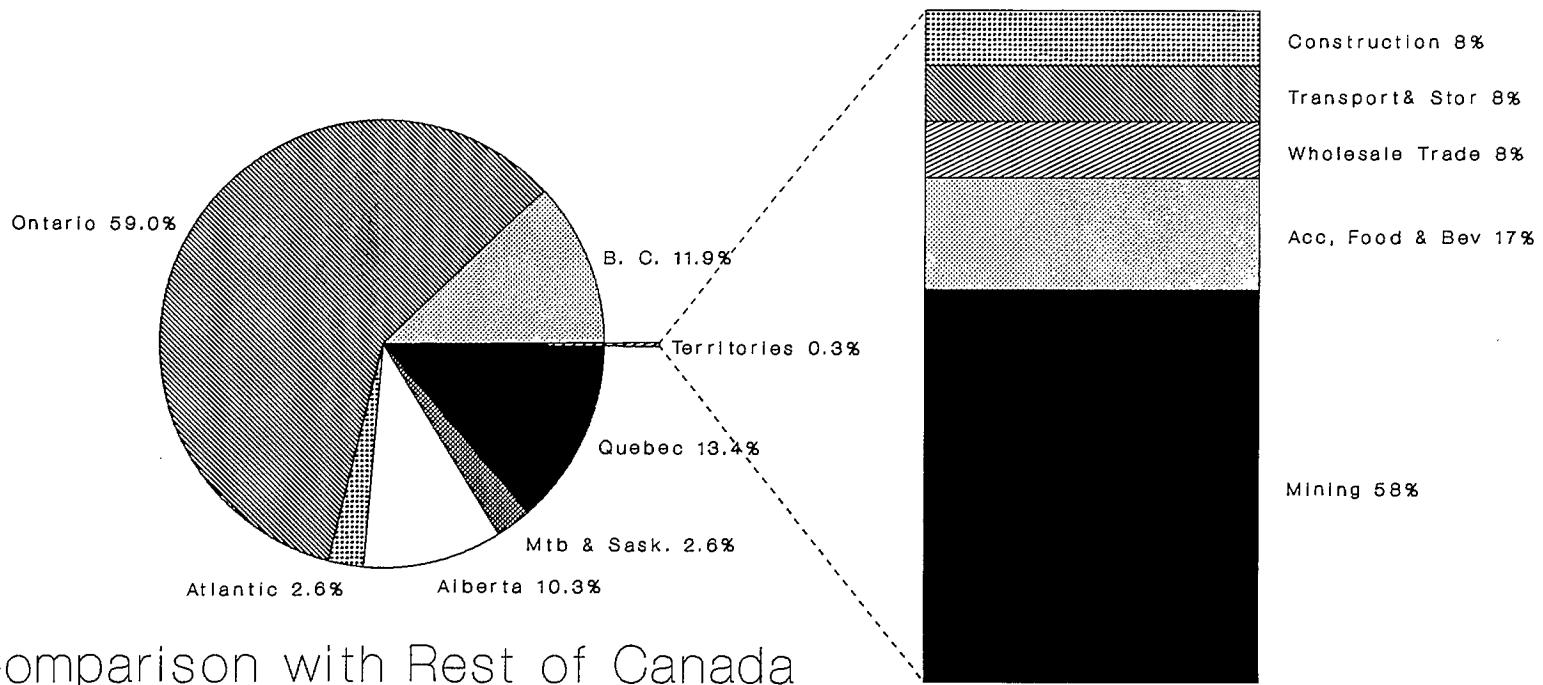

Comparison with Rest of Canada

Industrial Sectors

includes direct, indirect and incidental investment

# **WORLD - MAJOR URBAN CENTRES - AN OVERVIEW**

## **OVERVIEW**

Investment in the selected urban centres accounts for % of the asset value and % of the frequency of the total for Canada.

## **MONTREAL**

### **COMPARISON WITH QUEBEC**

Montreal receives 5% of the asset value and 56% of the frequency of investment to Quebec. One direct acquisition by U.S. investors in the newsprint industry accounts for 44% of the total asset value of investment in Montreal.

### **TYPES OF INVESTMENT**

73% of the asset value and 90% of the frequency of total investment was direct. New business accounted for 8% of the asset value and 45% of the frequency of direct investment.

### **INDUSTRY SECTORS**

Manufacturing industries attracted the greatest asset value of investment with 78% of the total. No other industry sector attracted a significant portion of the total asset value of investment.

Manufacturing and wholesale trade industries were the most frequent targets with 28% of the total number of transactions, each. Wholesale trade was particularly popular for new business. Business and other services, with 16% and 7% respectively, of the total frequency, were also significant.

## **TORONTO**

### **COMPARISON WITH ONTARIO**

Toronto receives 19% of the asset value and 34% of the frequency of investment to Ontario.



# **WORLD - MAJOR URBAN CENTRES - AN OVERVIEW**

## **TORONTO**

### **TYPES OF INVESTMENT**

67% of the asset value and 82% of the frequency of investment is direct. New business accounts for only 5% of the asset value and 59% of the frequency of direct investment. This discrepancy is due to the high frequency and low asset value of new business initiated in the wholesale trade and business services sectors.

### **INDUSTRY SECTORS**

Manufacturing attracts the greatest asset value of investment with 41% of the total. Finance and insurance (17%), real estate and insurance agents (15%), and construction (13%) are also significant with 8%. One direct acquisition in the non-residential building and development accounts for most of the asset value of investment in the construction industry.

Wholesale trade is the most frequented sector with 24% of the total number of transactions. As usual, a large portion, 70%, of these transactions are new businesses. Manufacturing (23%), business services (20%), other services (9%), finance and insurance (7%), and real estate and insurance agents (6%) were also popular.

## **CALGARY**

### **COMPARISON WITH ALBERTA**

Calgary receives 7% of the asset value and 29% of the frequency of transactions occurring in Alberta. One indirect acquisition by U.S. investors of a grocery retail chain comprised 33% of the asset value of investment made in Calgary.

# **WORLD - MAJOR URBAN CENTRES - AN OVERVIEW**

## **CALGARY**

### **TYPES OF INVESTMENT**

61% of the asset value and 91% of the frequency of investment were direct. New business accounted for 6% of the asset value and 48% of the frequency of direct investment.

### **INDUSTRY SECTORS**

Retail trade is the dominant target with 35% of the total asset value of investment. Wholesale trade (26%), manufacturing (18%), and real estate and insurance agents (11%) were also significant.

Business services (25%), wholesale trade (23%), and manufacturing (16%) are the most popular sectors.

## **VANCOUVER**

### **COMPARISON WITH BRITISH COLUMBIA**

Vancouver receives 84% of the asset value and 68% of the frequency of investment to British Columbia. A direct acquisition by New Zealand investors in the wood industries accounts for 33% of the asset value of investment.

### **TYPES OF INVESTMENT**

88% of the asset value and 96% of the frequency of investment was direct. New business accounts for 9% of the asset value and 41% of the frequency of direct investment.

### **INDUSTRY SECTORS**

Manufacturing attracted the greatest asset value of investment with 48% of the total. Real estate and insurance agents (19%), and accommodation, food and beverage (14%) are also significant.

## **WORLD - MAJOR URBAN CENTRES - AN OVERVIEW**

### **VANCOUVER**

**Real estate is the most popular sector with 18% of the total number of transactions. Wholesale trade (14%), business services (13%), manufacturing (12%), and other services (10%) were also preferred.**

# WORLD - MAJOR URBAN CENTRES 1985-1990

## OVERVIEW

### TOTAL ASSETS

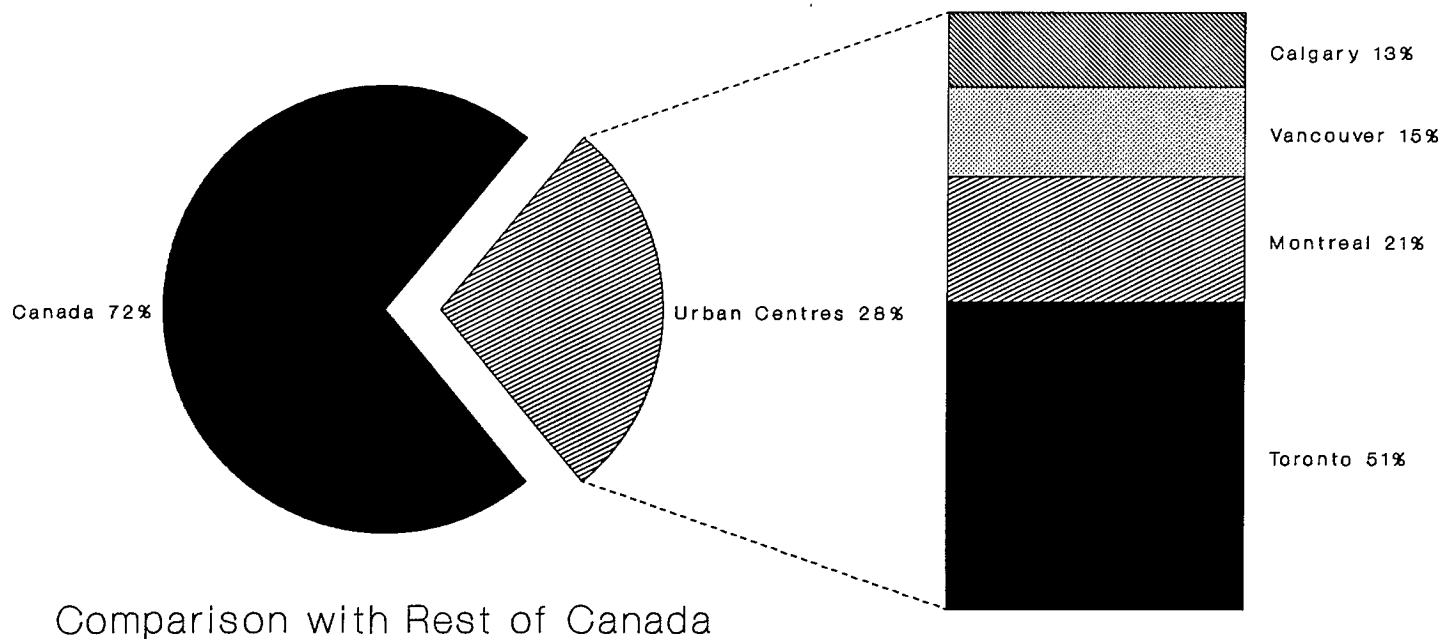

includes direct, indirect and incidental investment

Division Between Urban Centres

# WORLD - MAJOR URBAN CENTRES 1985-1990 OVERVIEW TOTAL FREQUENCIES

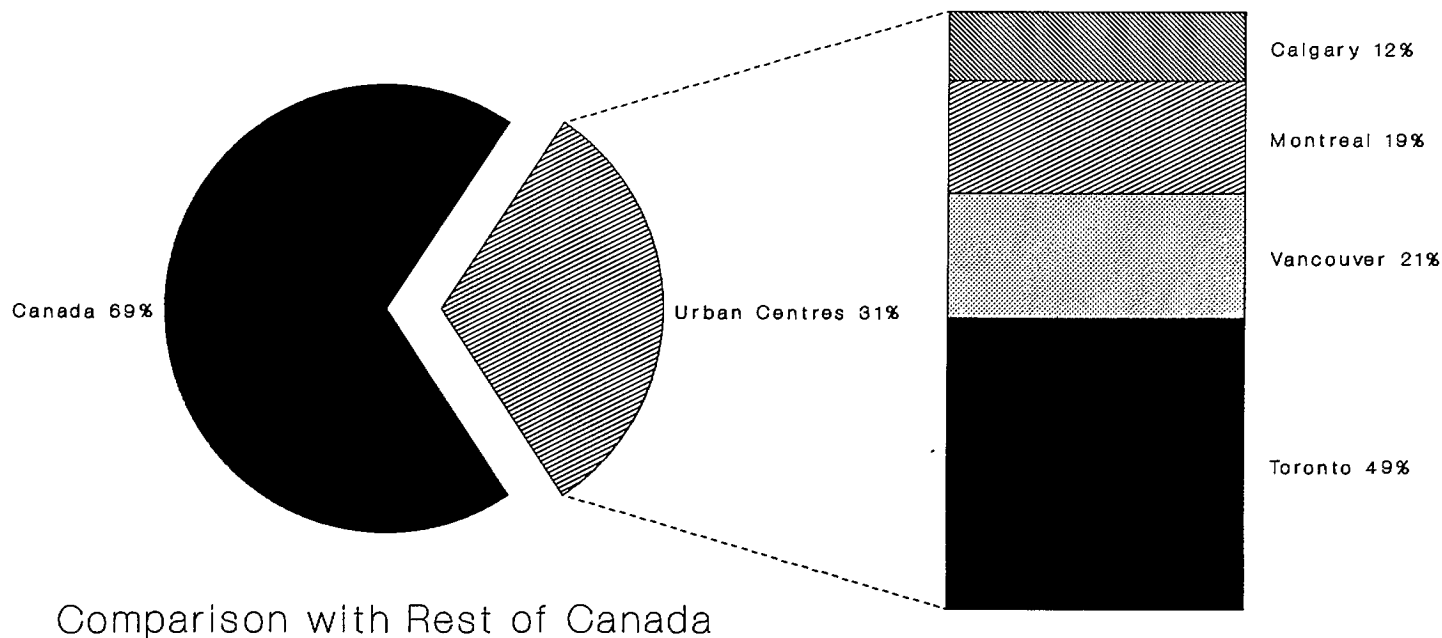

direct investment only

# WORLD - MAJOR URBAN CENTRES 1985-1990 OVERVIEW TOTAL ASSETS

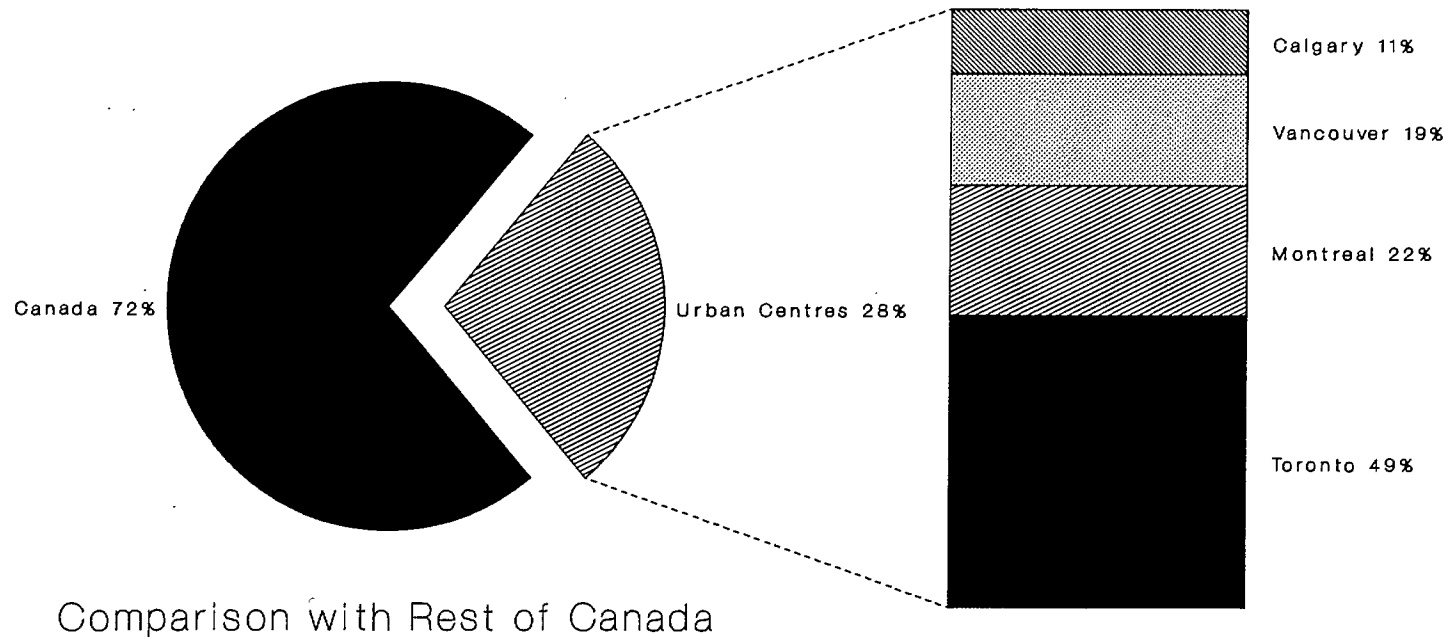

direct investment only

# WORLD - MONTREAL 1985-1990 COMPARISON WITH QUEBEC

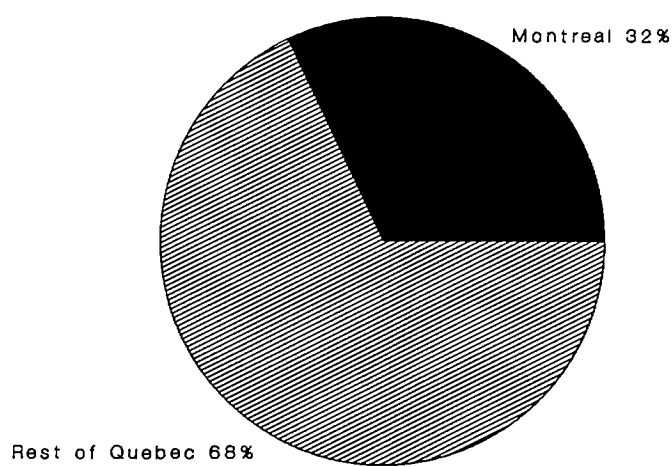

Total Assets

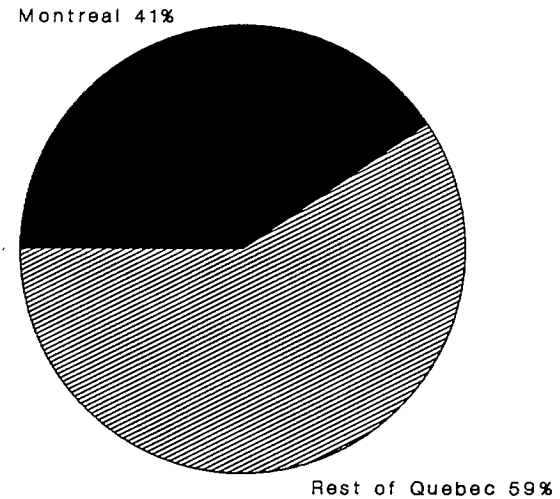

Total Frequencies

includes direct, indirect and incidental investment

# WORLD - MONTREAL 1985-1990 COMPARISON WITH QUEBEC

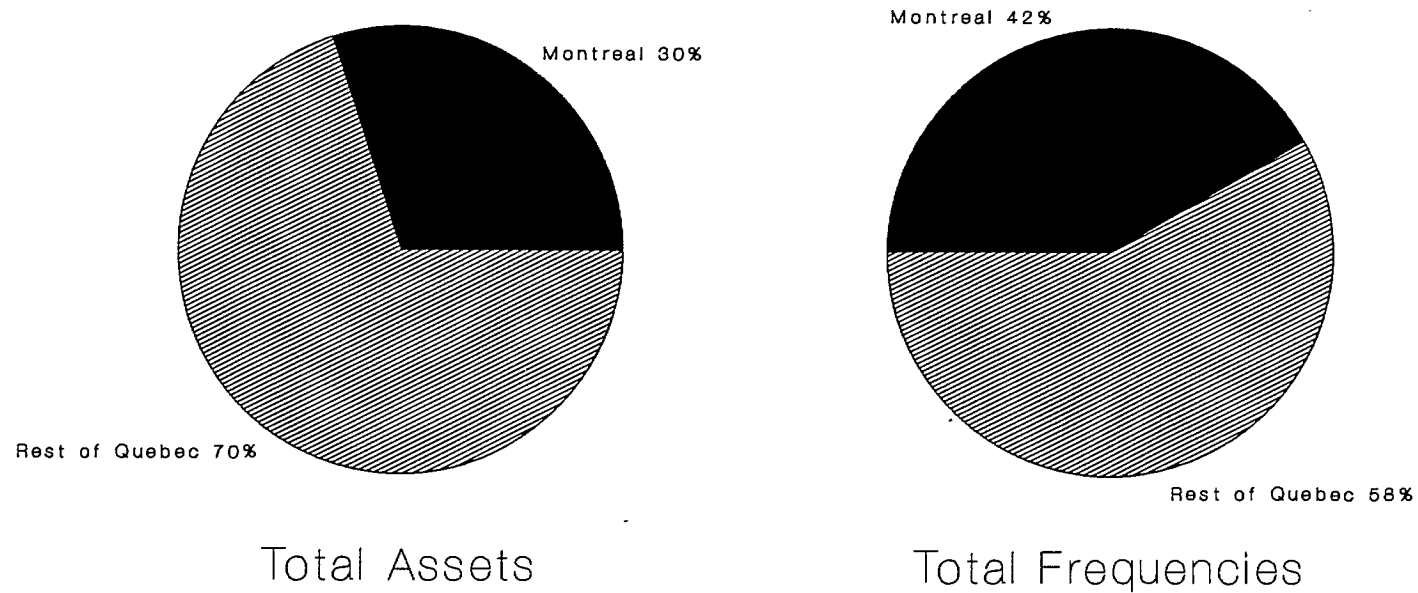

direct investment only



# WORLD - MONTREAL 1985-1990

## TYPES OF INVESTMENT

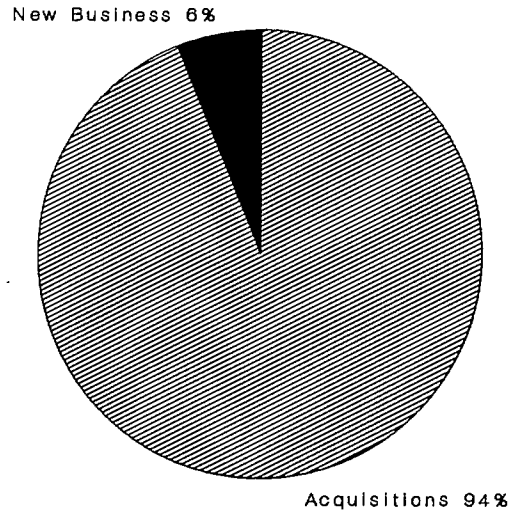

Total Assets

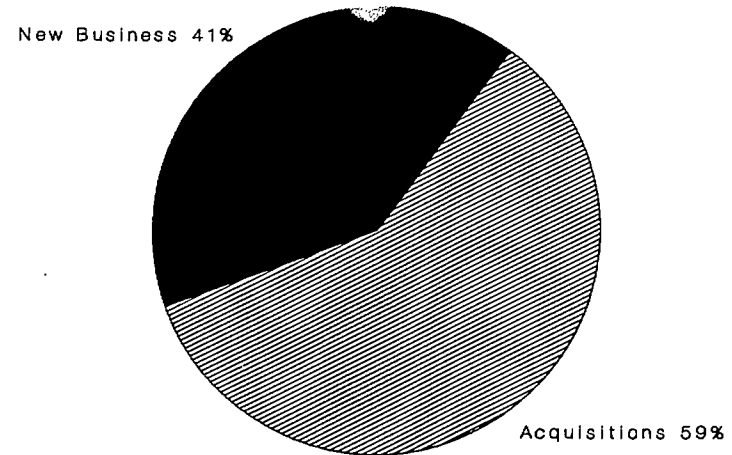

Total Frequencies

includes direct, indirect and incidental investment

# WORLD - MONTREAL 1985-1990

## TYPES OF INVESTMENT

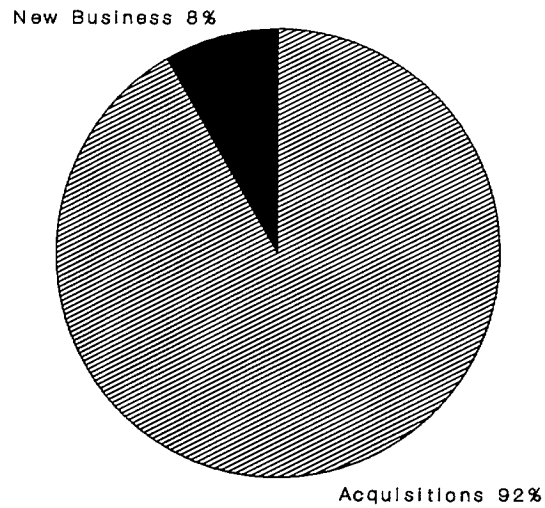

Total Assets

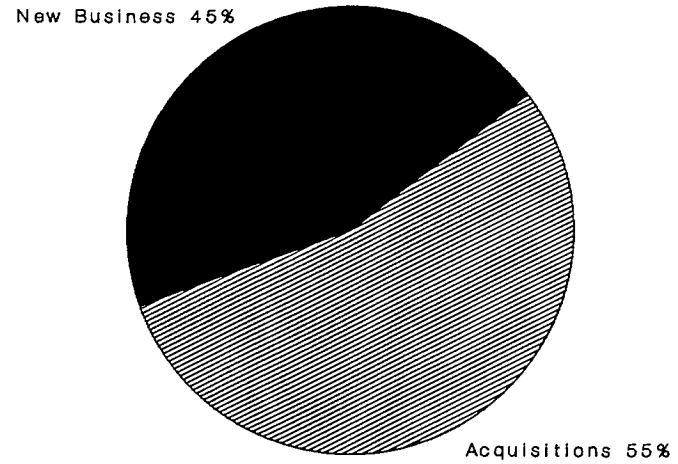

Total Frequencies

direct investment only

# WORLD - MONTREAL 1985-1990

## INDUSTRY SECTORS

### TOTAL ASSETS

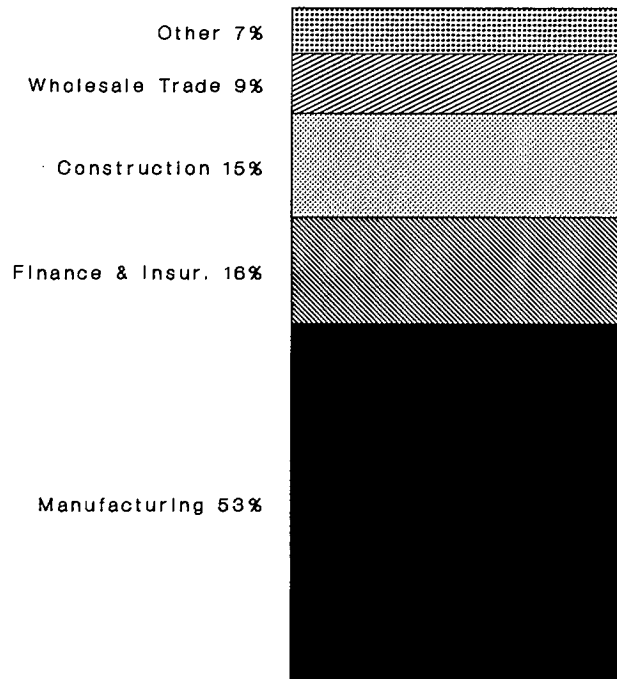

New Business

includes direct, indirect and incidental investment

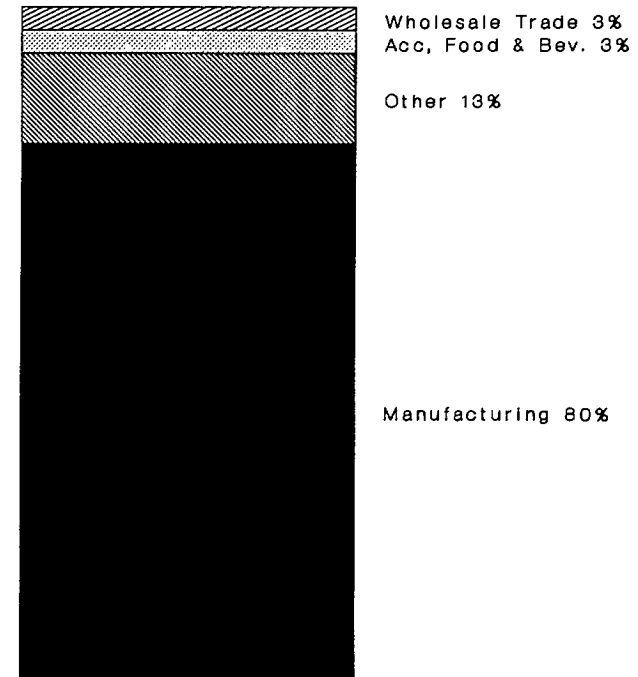

Acquisitions

# WORLD - MONTREAL 1985-1990

## INDUSTRY SECTORS

### TOTAL FREQUENCIES

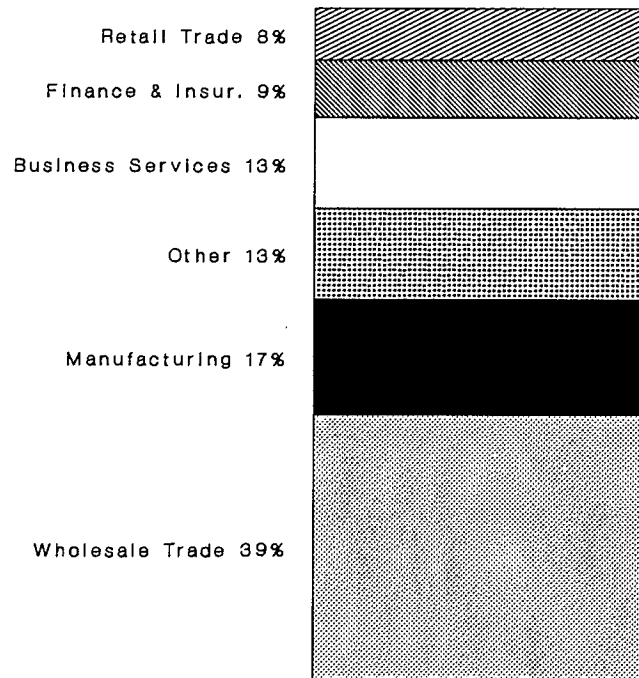

New Business

includes direct, indirect and incidental investment

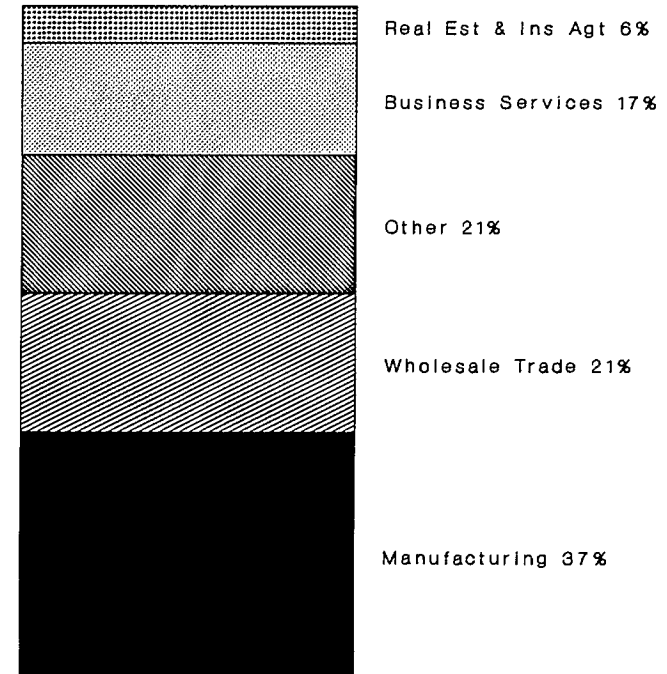

Acquisitions

# WORLD - MONTREAL 1985-1990

## INDUSTRY SECTORS

### TOTAL ASSETS

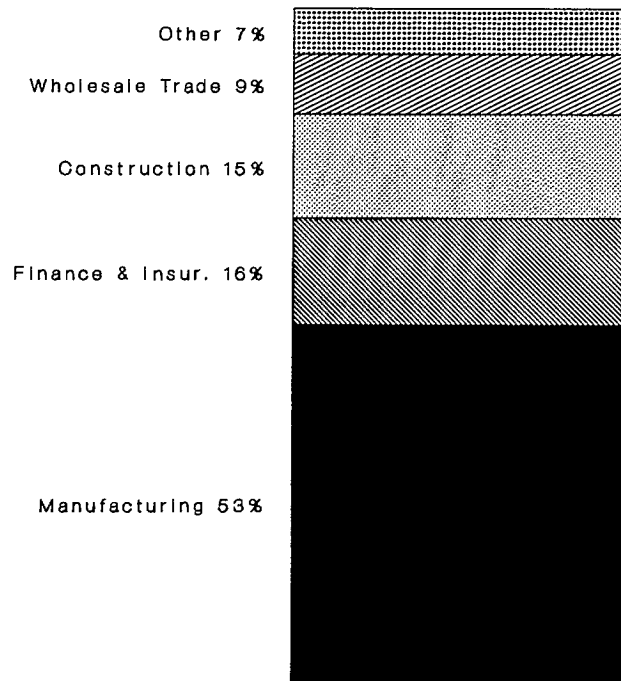

New Business

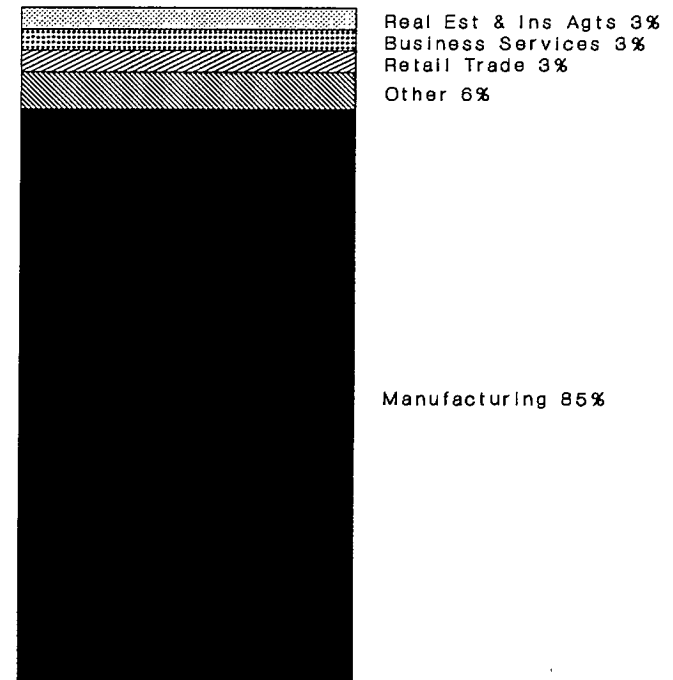

Acquisitions

direct investment only

# WORLD - MONTREAL 1985-1990

## INDUSTRY SECTORS

### TOTAL FREQUENCIES

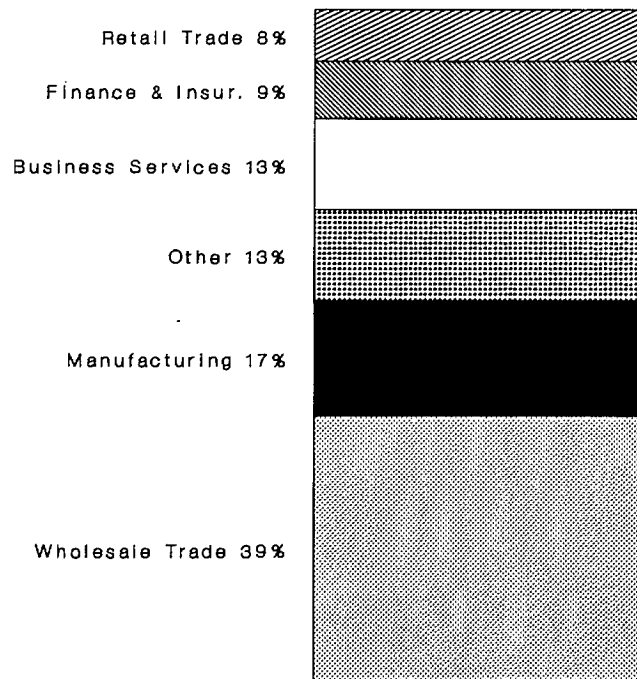

New Business

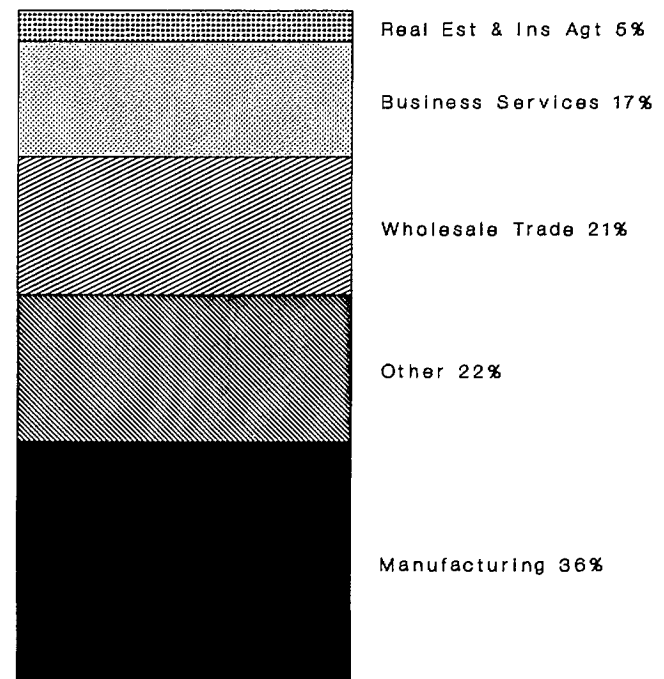

Acquisitions

direct investment only

# WORLD - TORONTO 1985-1990 COMPARISON WITH ONTARIO

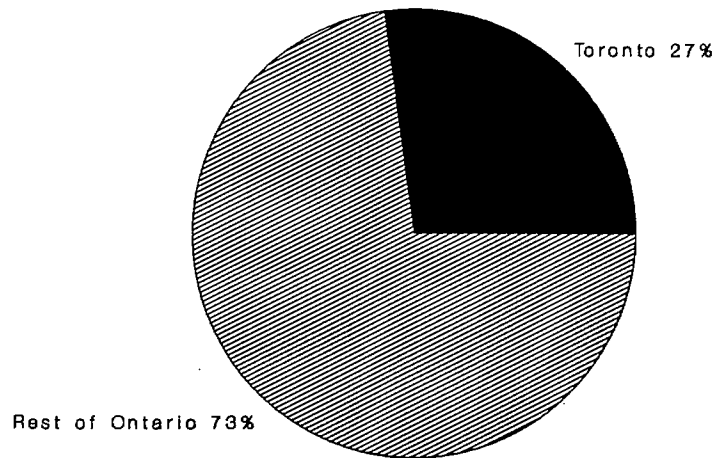

Total Assets

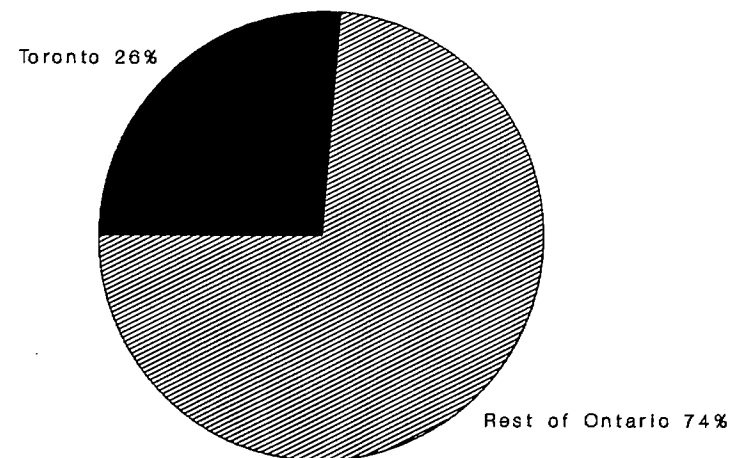

Total Frequencies

includes direct, indirect and incidental investment

# WORLD - TORONTO 1985-1990 COMPARISON WITH ONTARIO

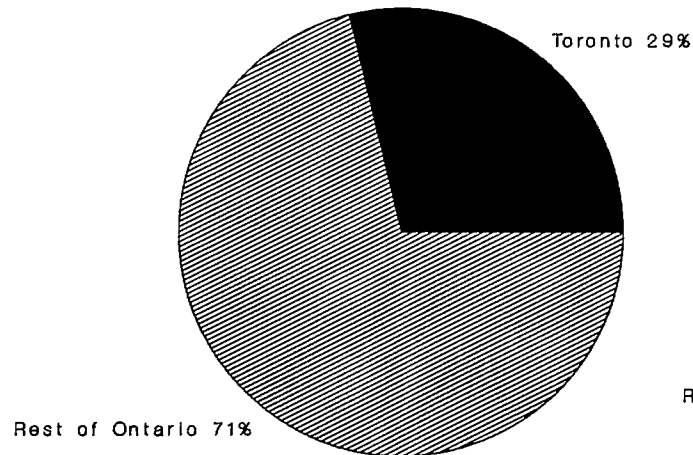

Total Assets

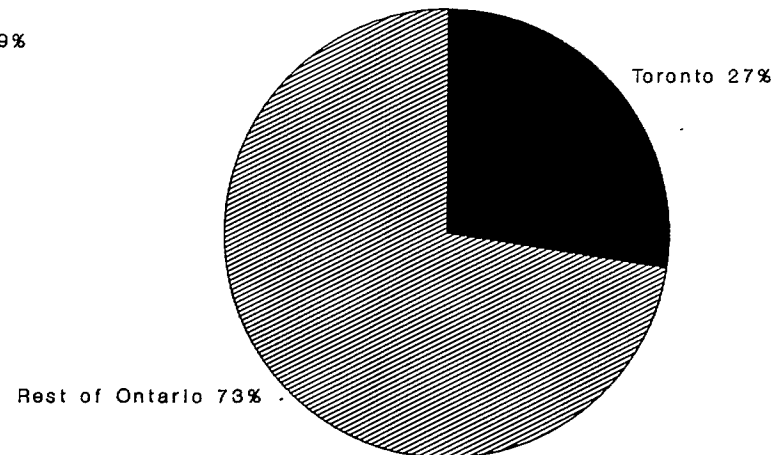

Total Frequencies

direct investment only



# WORLD - TORONTO 1985-1990

## TYPES OF INVESTMENT

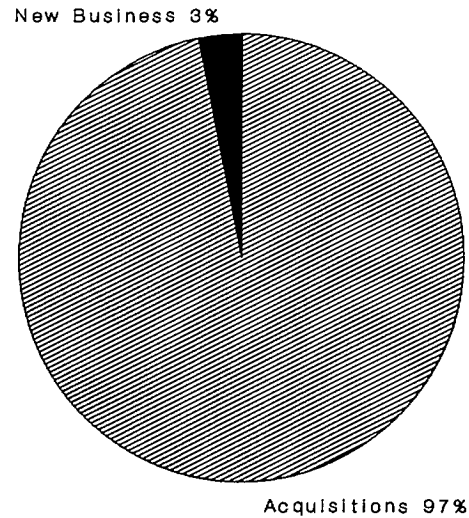

Total Assets

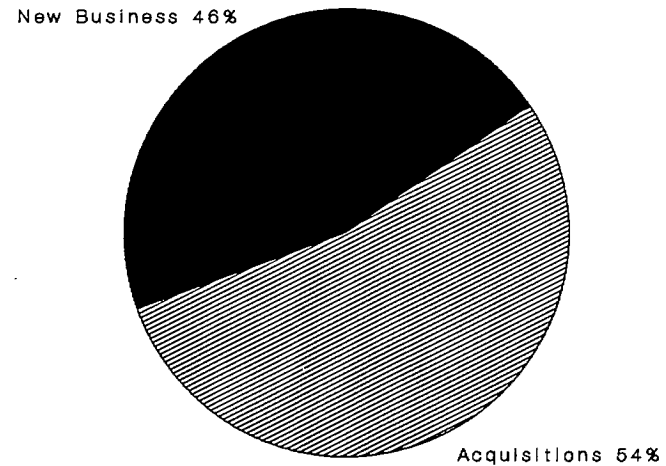

Total Frequencies

includes direct, indirect and incidental investment

# WORLD - TORONTO 1985-1990

## TYPES OF INVESTMENT

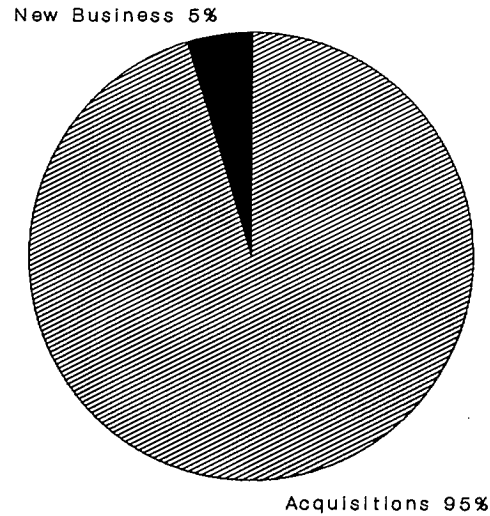

Total Assets

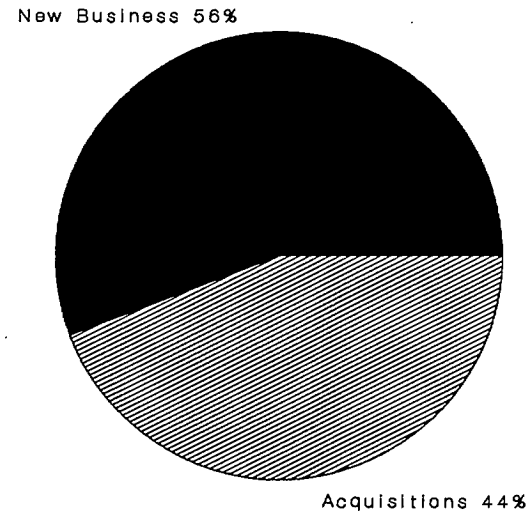

Total Frequencies

direct investment only

# WORLD - TORONTO 1985-1990

## INDUSTRY SECTORS

### TOTAL ASSETS

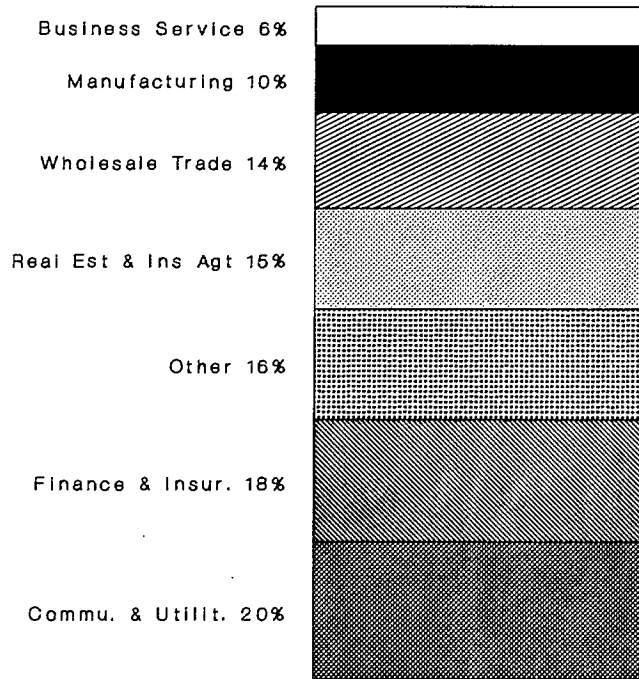

New Business

includes direct, indirect and incidental investment

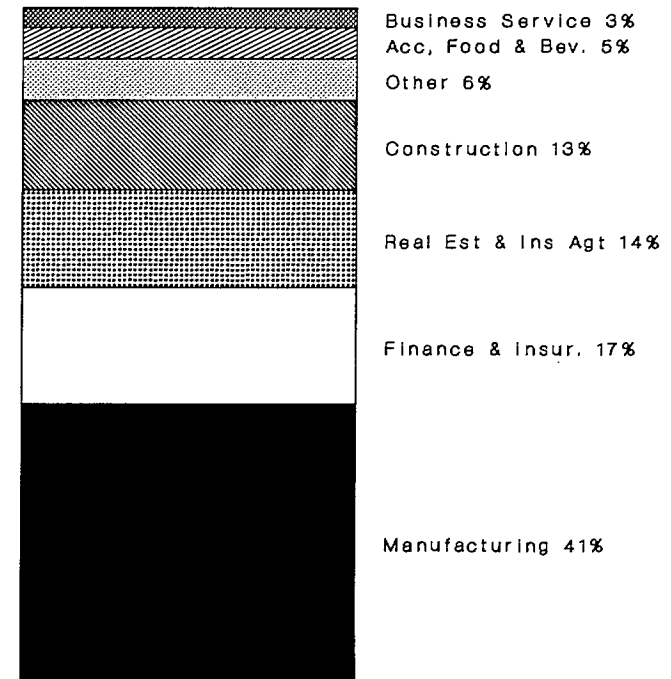

Acquisitions

# WORLD - TORONTO 1985-1990

## INDUSTRY SECTORS

### TOTAL FREQUENCIES

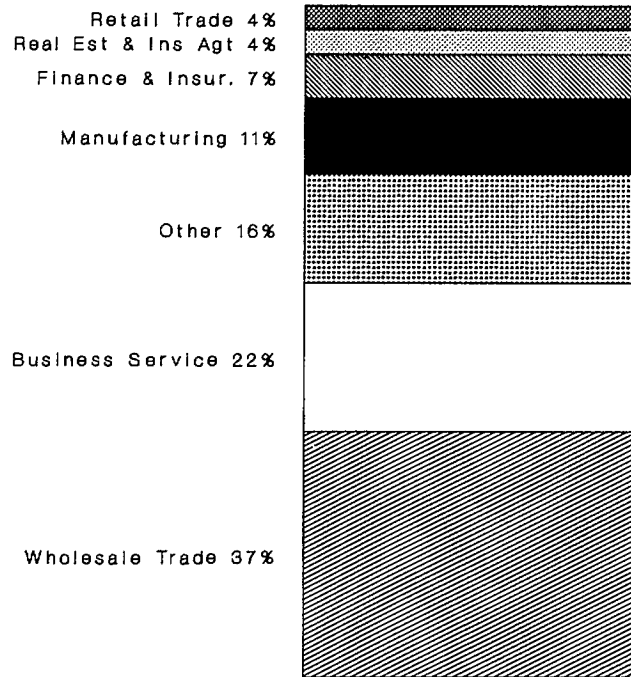

New Business

**includes direct, indirect and incidental investment**

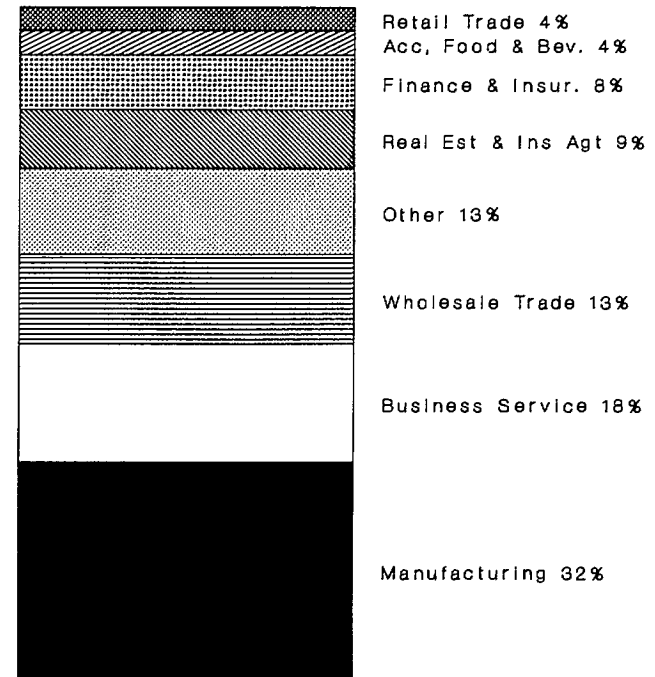

Acquisitions

# WORLD - TORONTO 1985-1990

## INDUSTRY SECTORS

### TOTAL ASSETS

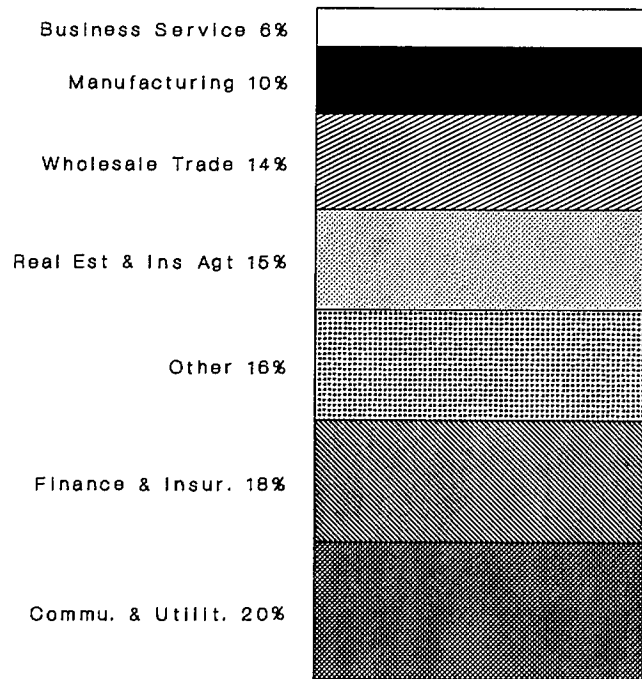

New Business

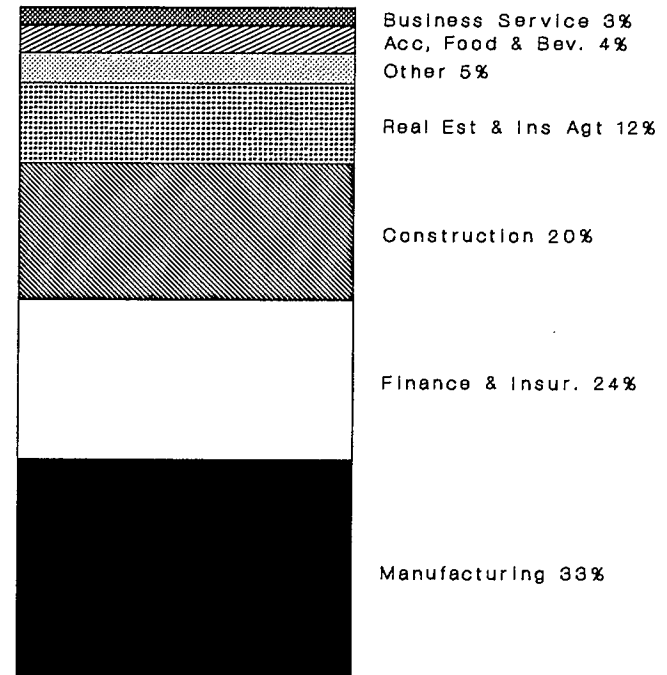

Acquisitions

direct investment only

# WORLD - TORONTO 1985-1990

## INDUSTRY SECTORS

### TOTAL FREQUENCIES

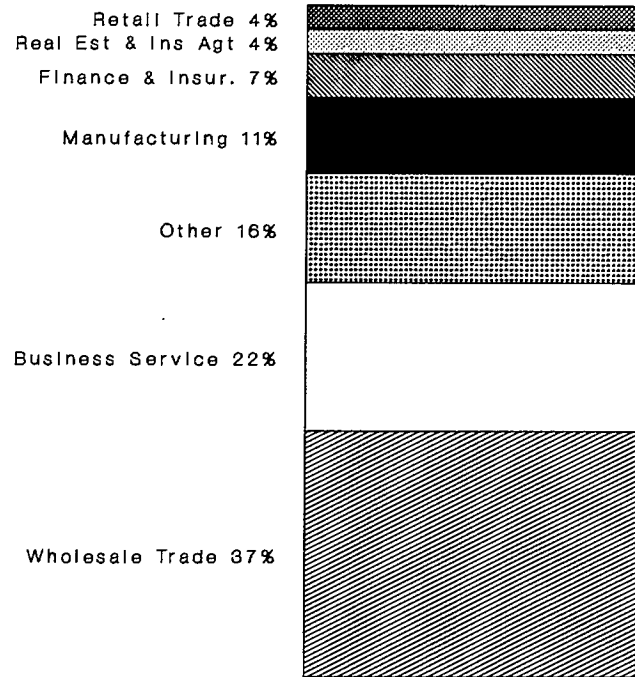

New Business

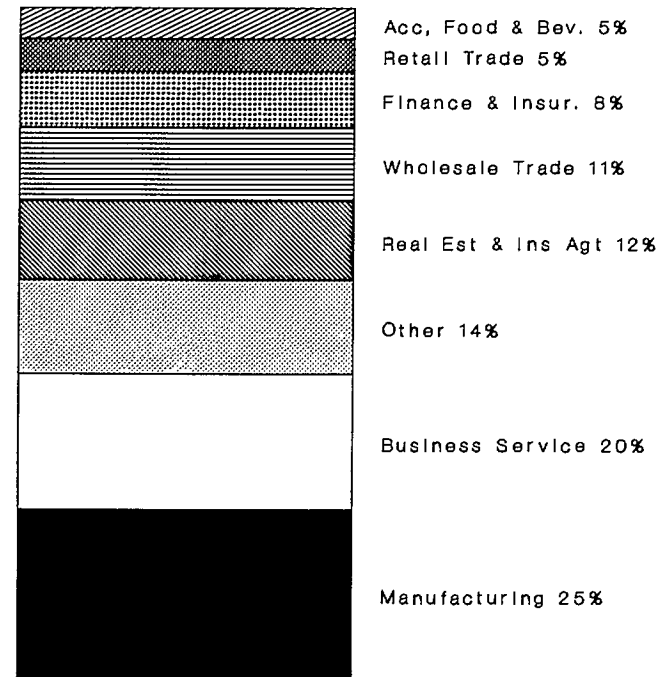

Acquisitions

direct investment only

# WORLD - CALGARY 1985-1990 COMPARISON WITH ALBERTA

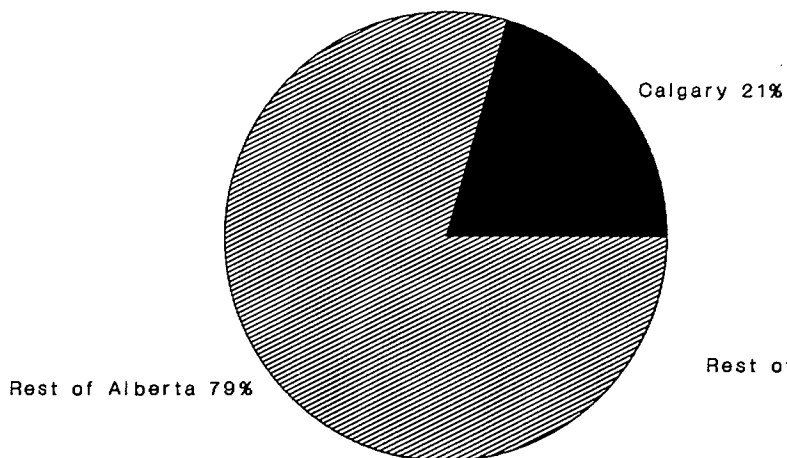

Total Assets

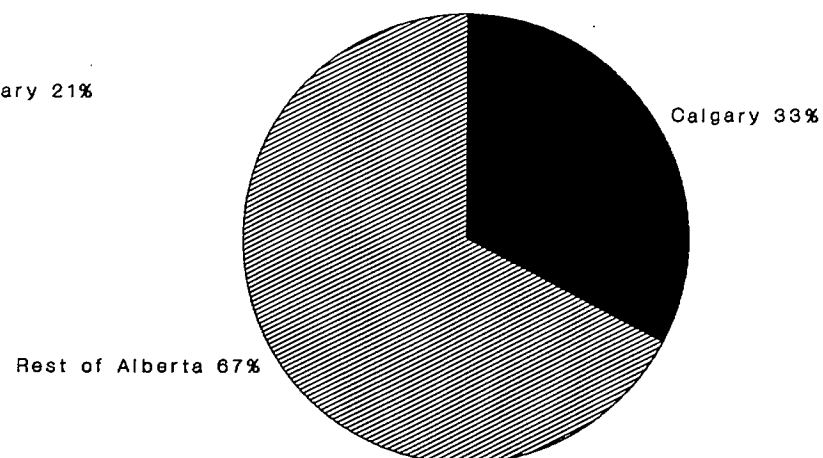

Total Frequencies

includes direct, indirect and incidental investment

# WORLD - CALGARY 1985-1990 COMPARISON WITH ALBERTA

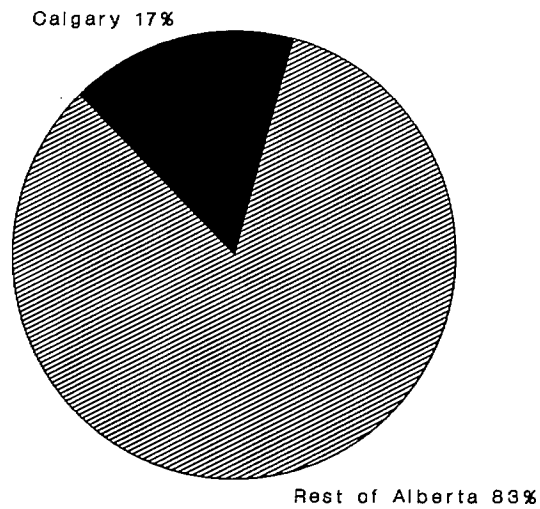

Total Assets

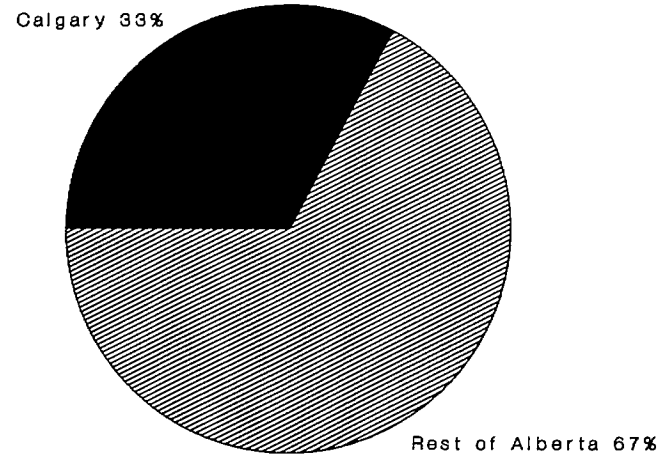

Total Frequencies

direct investment only



# WORLD - CALGARY 1985-1990

## TYPES OF INVESTMENT

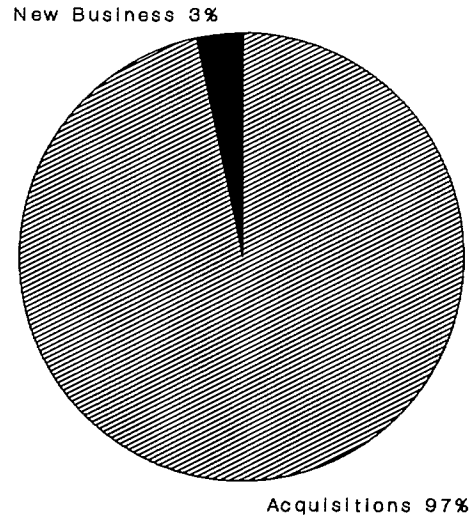

Total Assets

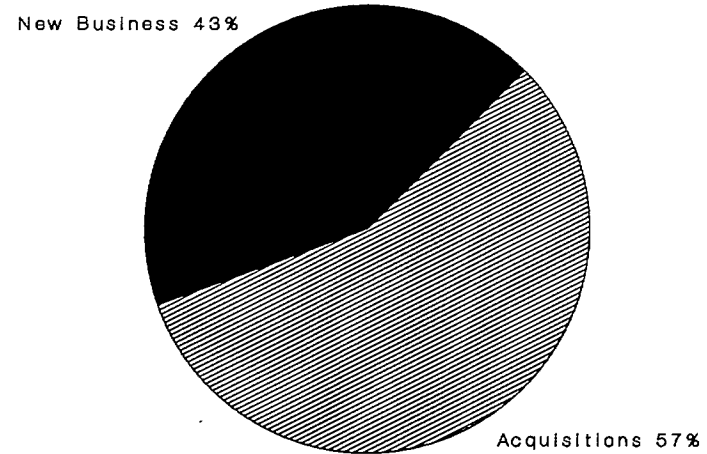

Total Frequencies

includes direct, indirect and incidental investment

# WORLD - CALGARY 1985-1990

## TYPES OF INVESTMENT

New Business 6%

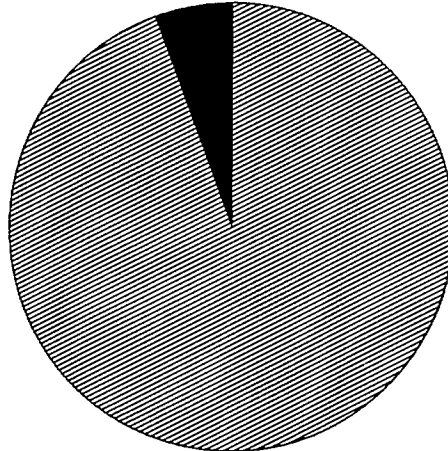

Acquisitions 94%

Total Assets

New Business 48%

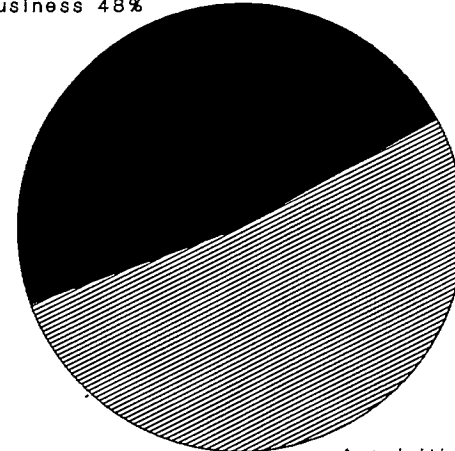

Acquisitions 52%

Total Frequencies

direct investment only

# WORLD - CALGARY 1985-1990

## INDUSTRY SECTORS

### TOTAL ASSETS

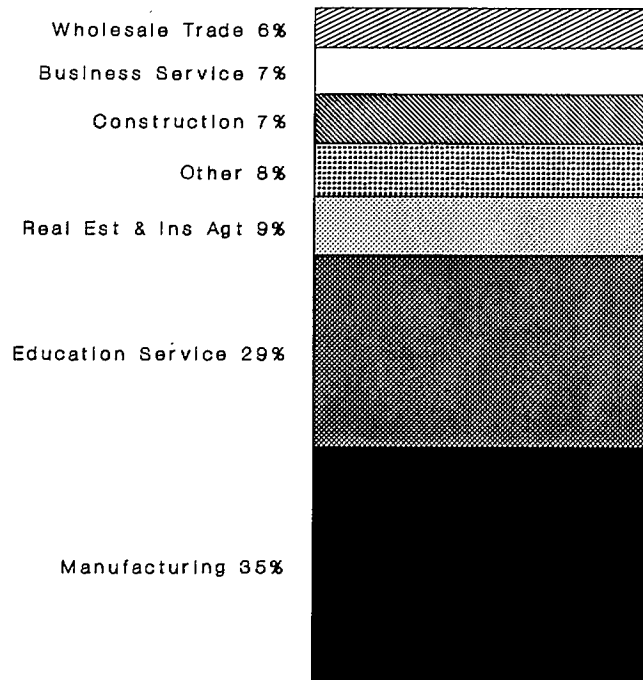

New Business

includes direct, indirect and incidental investment

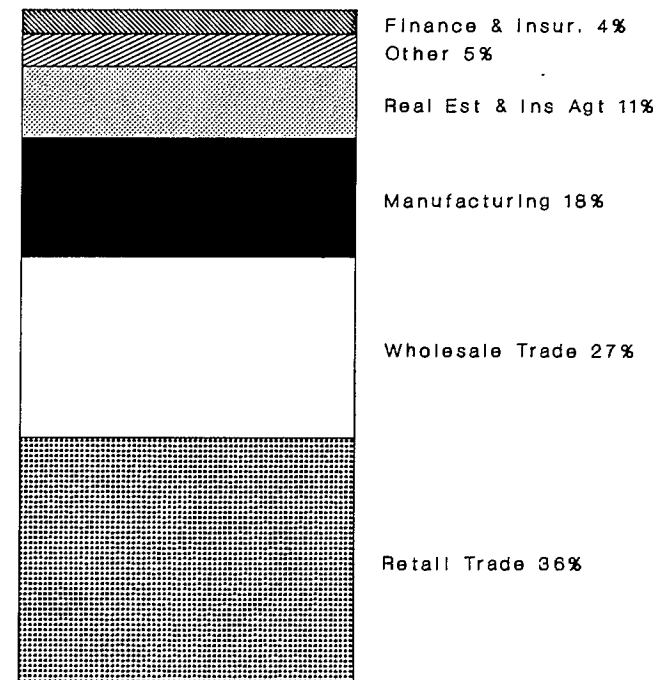

Acquisitions

# WORLD - CALGARY 1985-1990

## INDUSTRY SECTORS

### TOTAL FREQUENCIES

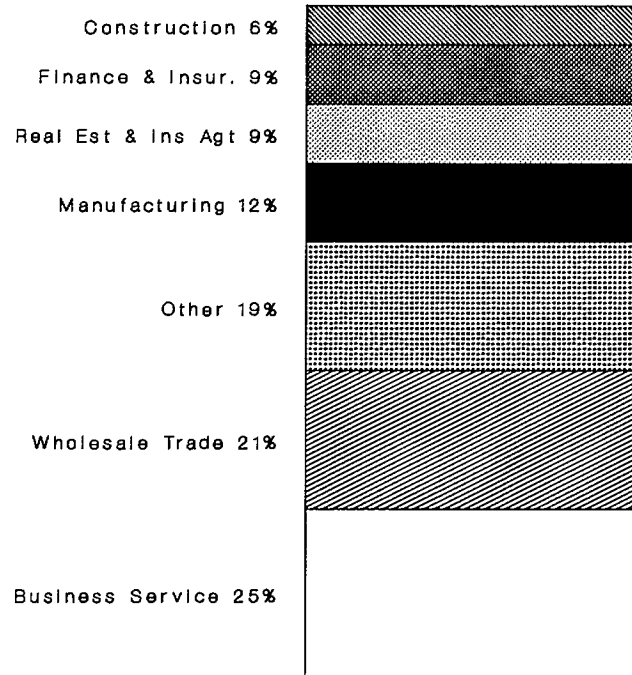

New Business

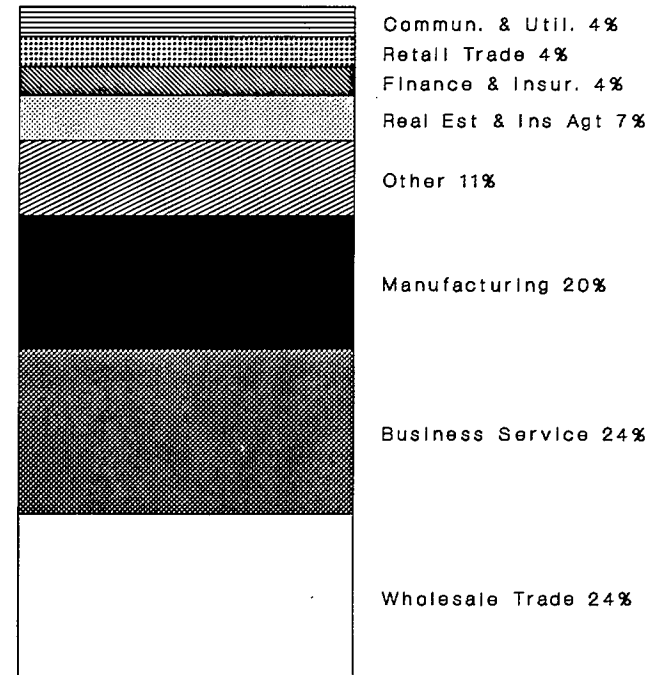

Acquisitions

includes direct, indirect and incidental investment

# WORLD - CALGARY 1985-1990

## INDUSTRY SECTORS

### TOTAL ASSETS

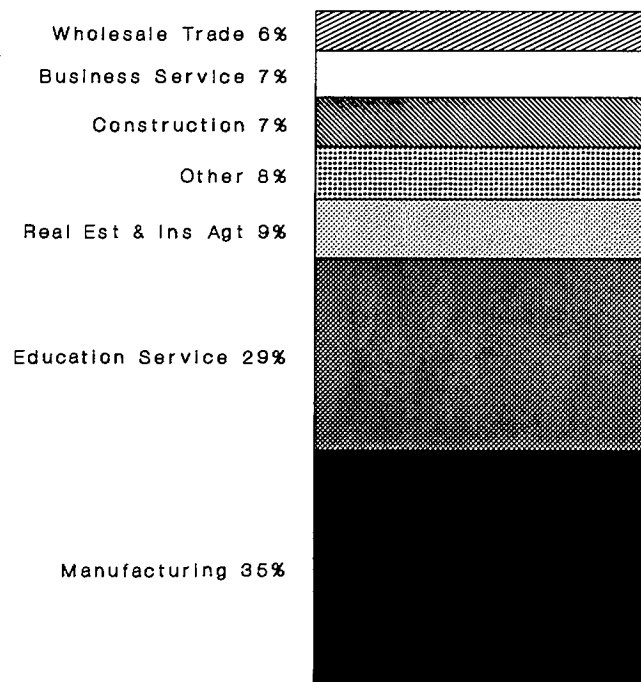

New Business

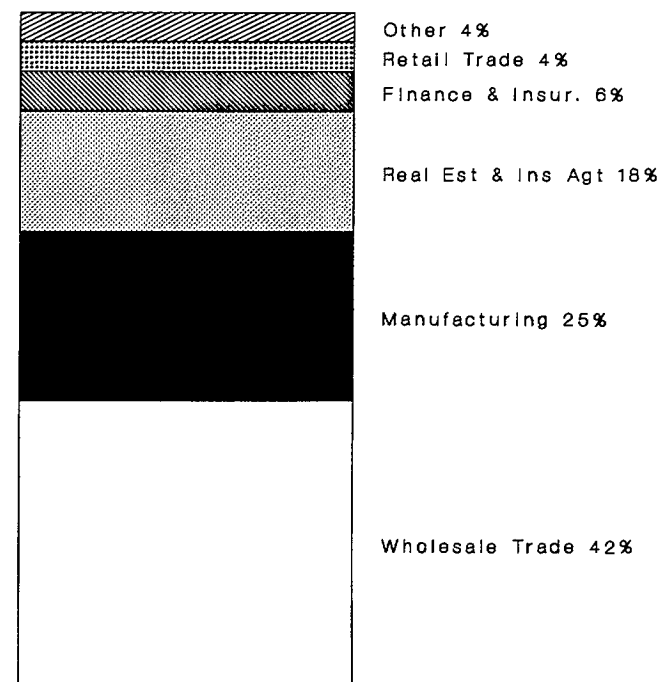

Acquisitions

direct investment only

# WORLD - CALGARY 1985-1990

## INDUSTRY SECTORS

### TOTAL FREQUENCIES

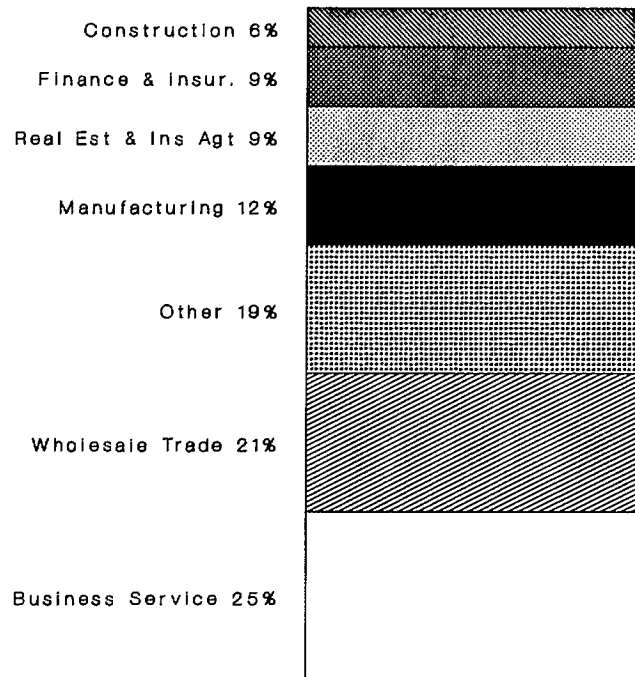

New Business

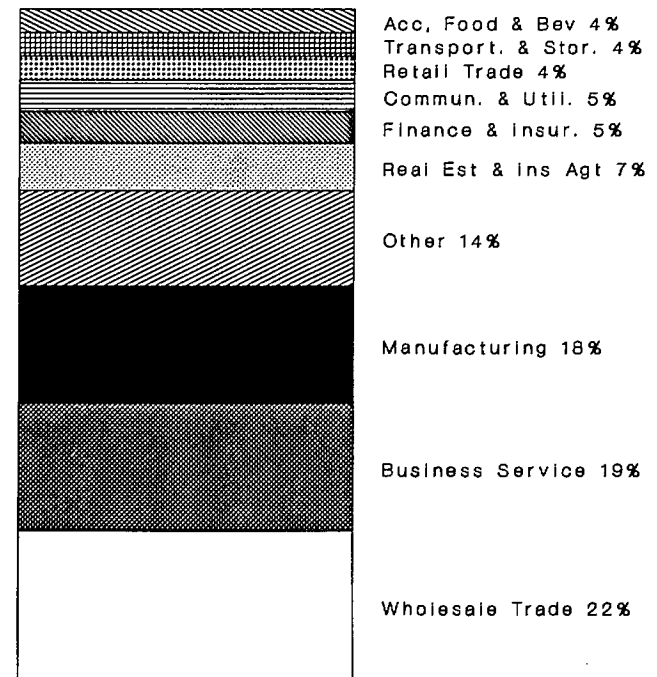

Acquisitions

direct investment only

# WORLD - VANCOUVER 1985-1990 COMPARISON WITH BRITISH COLUMBIA

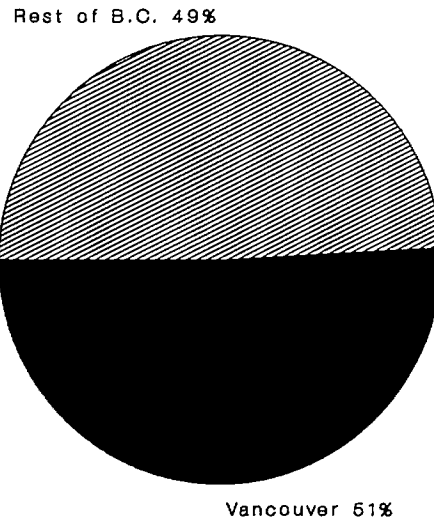

Total Assets

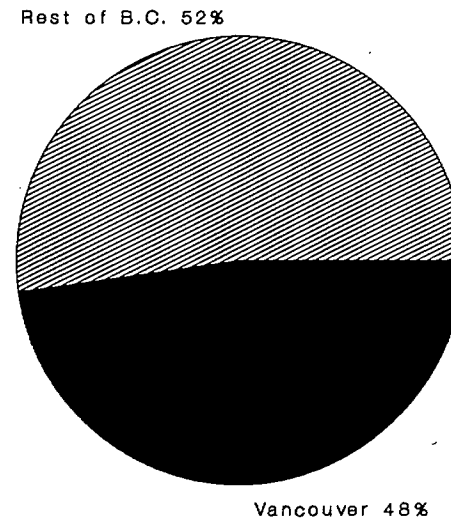

Total Frequencies

includes direct, indirect and incidental investment

# WORLD - VANCOUVER 1985-1990 COMPARISON WITH BRITISH COLUMBIA

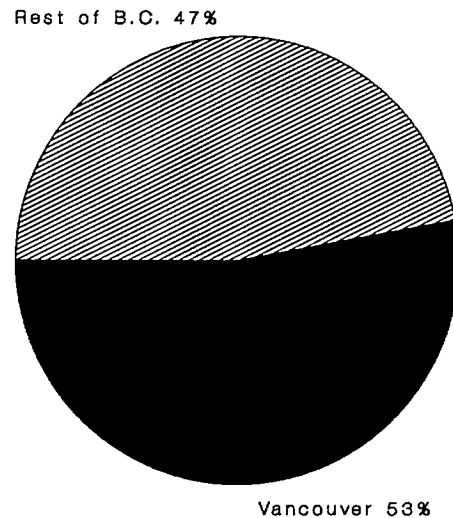

Total Assets

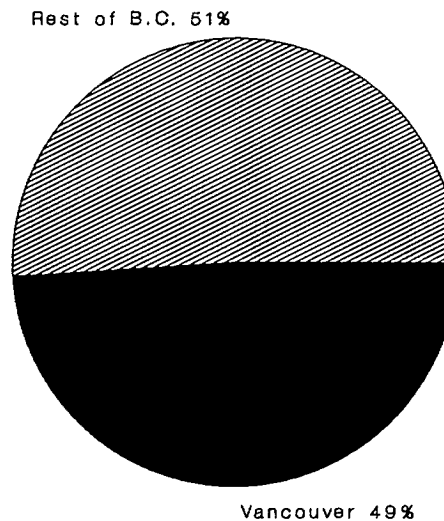

Total Frequencies

direct investment only



# WORLD - VANCOUVER 1985-1990

## TYPES OF INVESTMENT

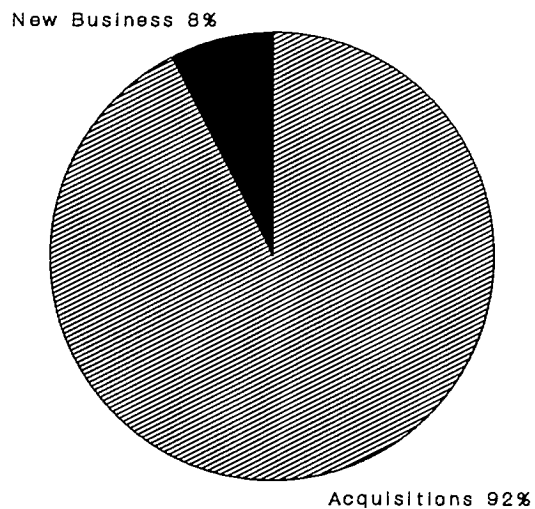

Total Assets

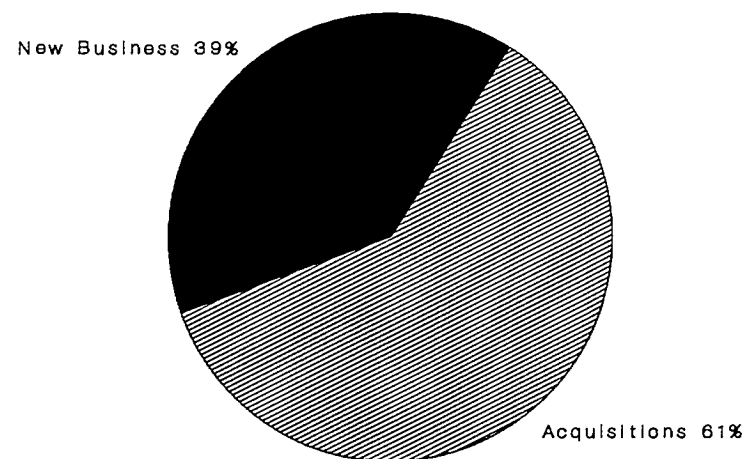

Total Frequencies

includes direct, indirect and incidental investment

# WORLD - VANCOUVER 1985-1990

## TYPES OF INVESTMENT

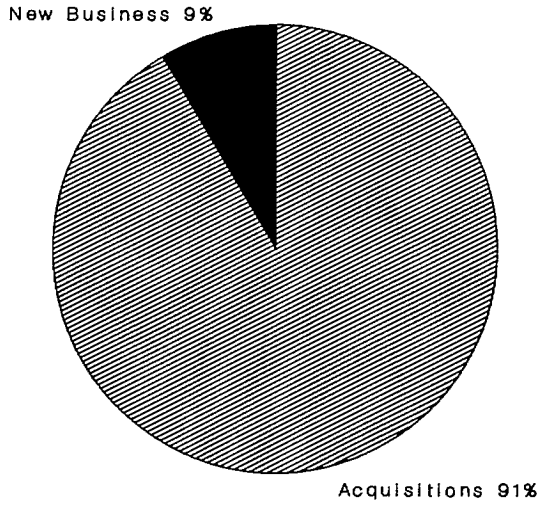

Total Assets

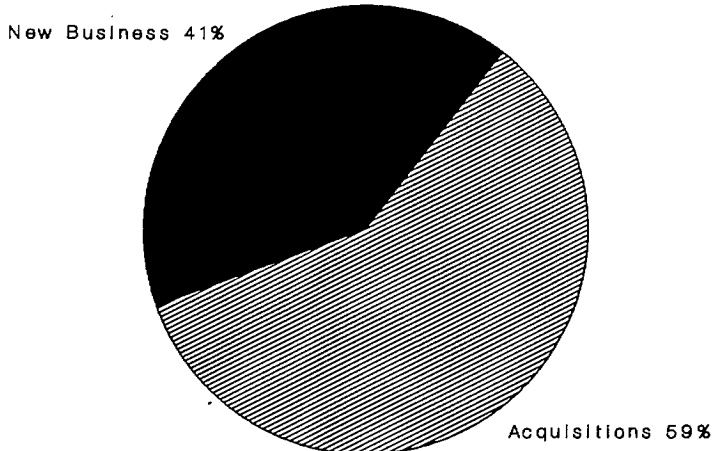

Total Frequencies

direct investment only

# WORLD - VANCOUVER 1985-1990

## INDUSTRY SECTORS

### TOTAL ASSETS

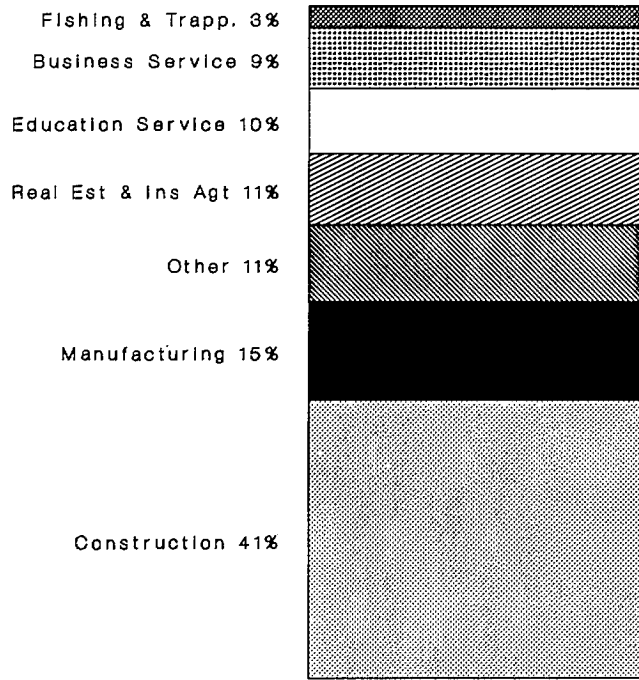

New Business

**includes direct, indirect and incidental investment**

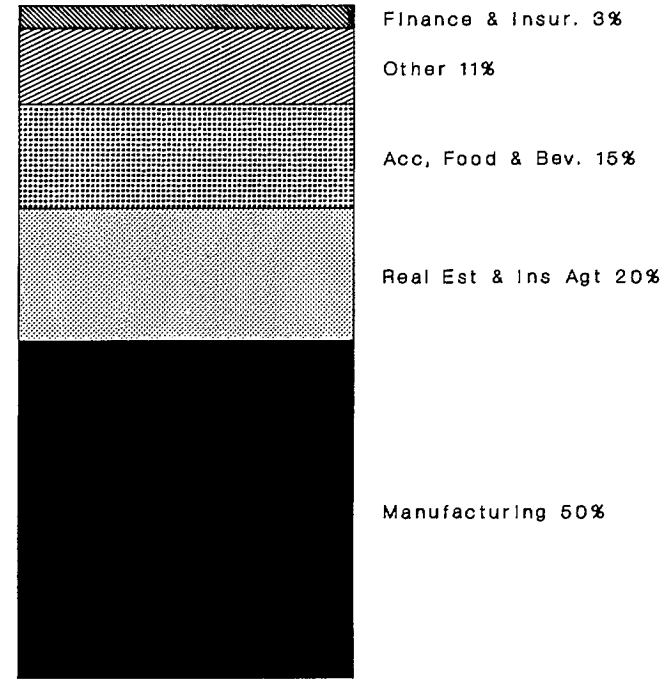

Acquisitions

# WORLD - VANCOUVER 1985-1990

## INDUSTRY SECTORS

### TOTAL FREQUENCIES

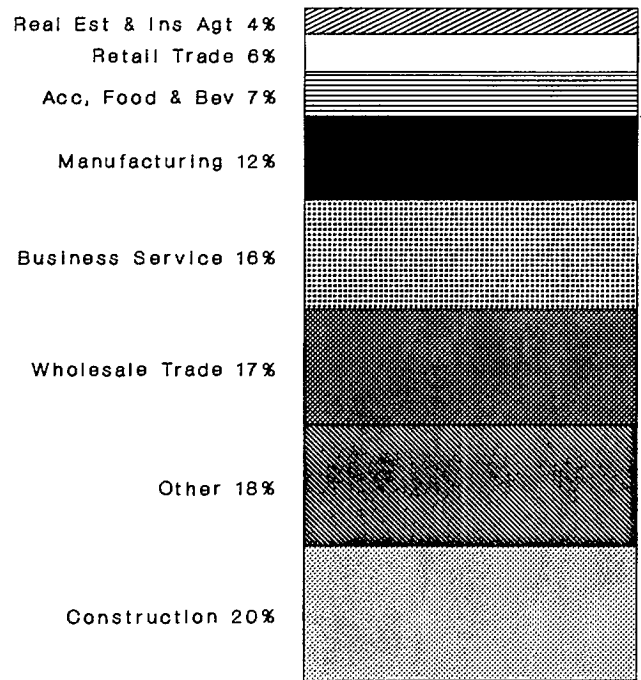

New Business

includes direct, indirect and incidental investment

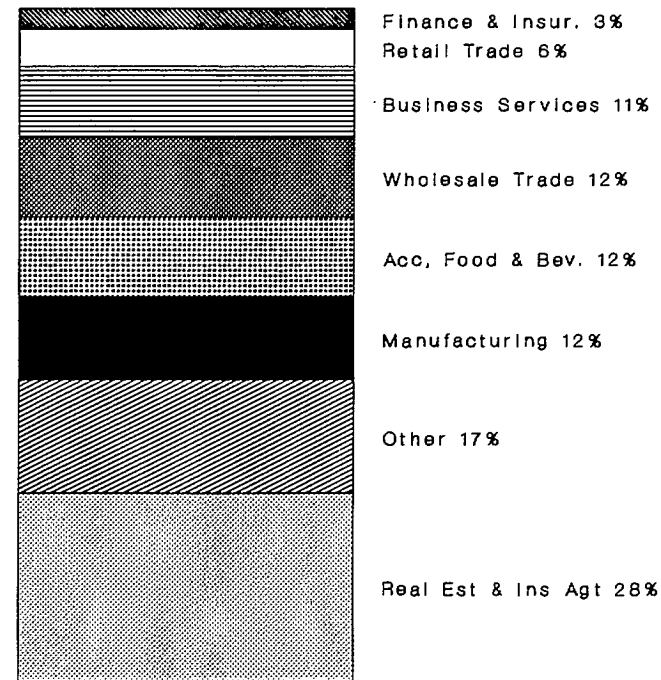

Acquisitions

# WORLD - VANCOUVER 1985-1990

## INDUSTRY SECTORS

### TOTAL ASSETS

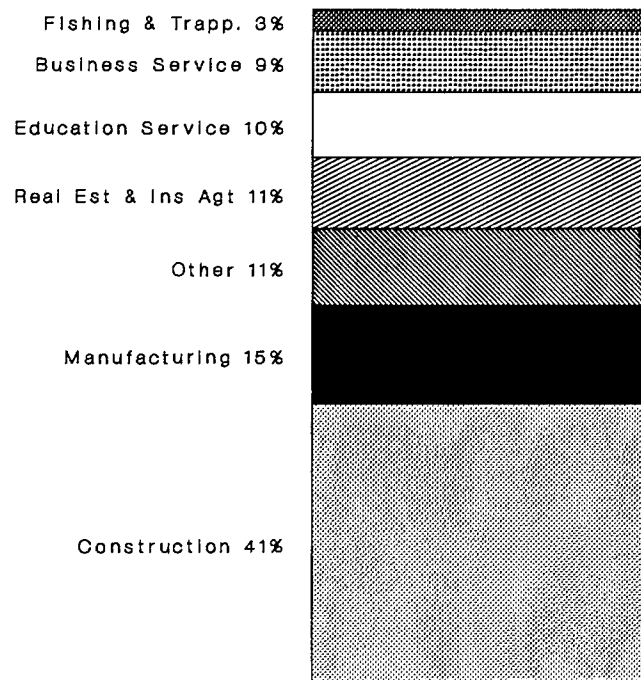

New Business

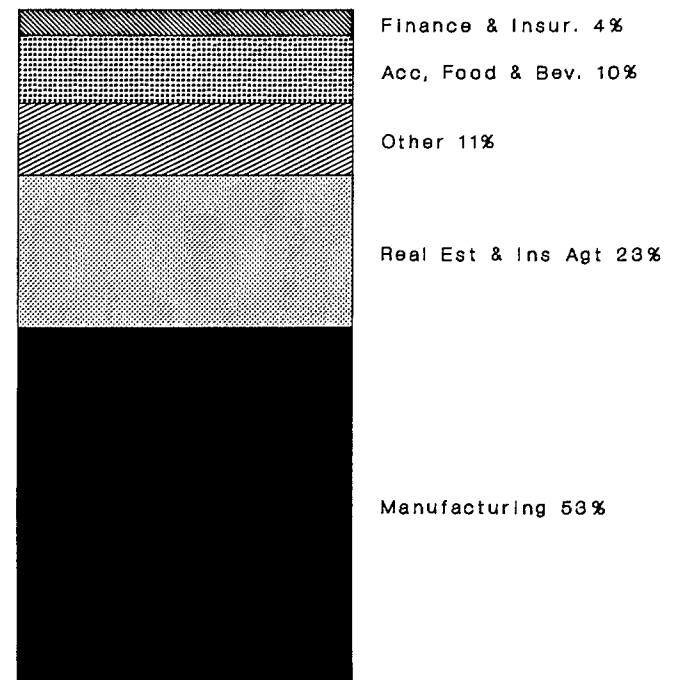

Acquisitions

direct investment only

# WORLD - VANCOUVER 1985-1990

## INDUSTRY SECTORS

### TOTAL FREQUENCIES

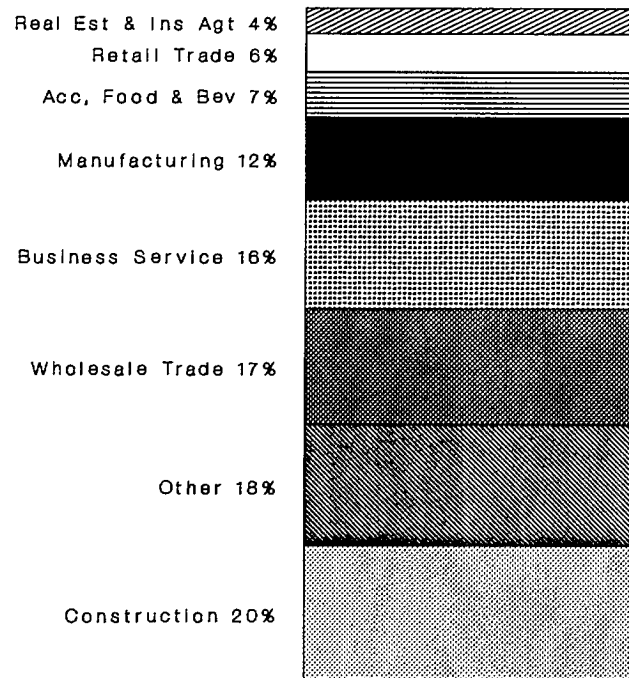

New Business

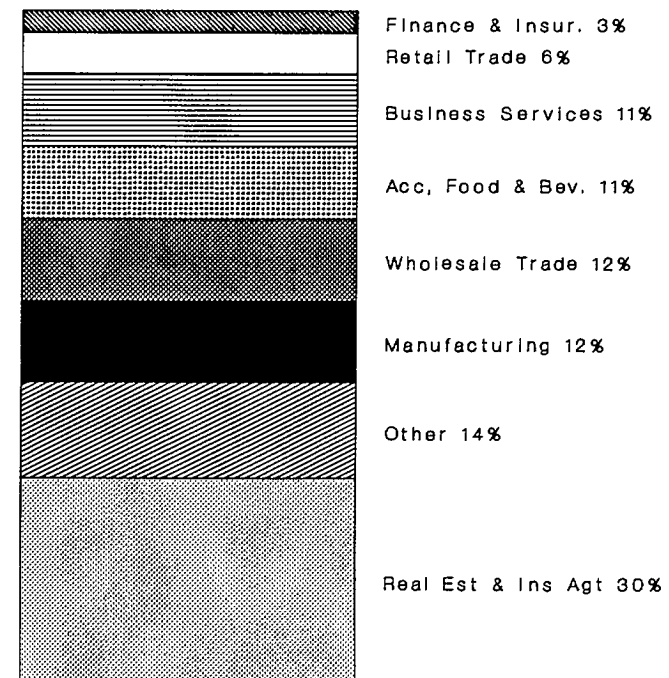

Acquisitions

direct investment only

World

CANADA:  
(including indirect and incidental investment)

Sector:	Asset Value:			% of Tot. Asset Value			Frequency:			% of Tot. Frequency:		
	New:	Acqu.:	Tot.	New:	Acqu.:	Tot:	New:	Acqu.:	Tot.	New:	Acqu.:	Tot.
Agriculture	5264	107600	112864	0.10	0.13	0.13	4	15	19	0.29	0.45	0.40
Fishing & Trapping	35583	19527	55110	0.66	0.02	0.06	7	8	15	0.50	0.24	0.32
Logging	275	61120	61395	0.01	0.07	0.07	2	5	7	0.14	0.15	0.15
Mining	237310	6212264	6449574	4.37	7.54	7.35	13	66	79	0.93	2.00	1.68
Petroleum & Natural Gas	245073	13965171	14210244	4.52	16.96	16.19	31	160	191	2.21	4.85	4.06
Manufacturing	2607851	37589597	40197448	48.08	45.65	45.80	243	1299	1542	17.36	39.35	32.80
Construction	402488	1831793	2234281	7.42	2.22	2.55	56	44	100	4.00	1.33	2.13
Transport. & Storage	36534	396370	432904	0.67	0.48	0.49	41	67	108	2.93	2.03	2.30
Communication & Utilities	88400	210558	298958	1.63	0.26	0.34	10	54	64	0.71	1.64	1.36
Wholesale Trade	274613	6258923	6533536	5.06	7.60	7.44	464	643	1107	33.14	19.48	23.55
Retail Trade	37156	2151173	2188329	0.68	2.61	2.49	62	126	188	4.43	3.82	4.00
Finance & Insurance	173926	3966331	4140257	3.21	4.82	4.72	57	62	119	4.07	1.88	2.53
Real Estate & Insurance Agt	177230	3713753	3890983	3.27	4.51	4.43	42	183	225	3.00	5.54	4.79
Business Services	214504	1081418	1295922	3.95	1.31	1.48	231	259	490	16.50	7.85	10.42
Educational Services	3952	41707	45659	0.07	0.05	0.05	10	5	15	0.71	0.15	0.32
Health & Social Services	30200	25440	55640	0.56	0.03	0.06	2	13	15	0.14	0.39	0.32
Accomodation, Food & Bev	50811	2269667	2320478	0.94	2.76	2.64	29	134	163	2.07	4.06	3.47
Other	803311	2441139	3244450	14.81	2.96	3.70	96	158	254	6.86	4.79	5.40
Total:	5424481	82343551	87768032	100	100	100	1400	3301	4701	100	100	100

World

CANADA:  
(direct investment only)

Sector:	Asset Value:			% of Tot. Asset Value			Frequency:			% of Tot. Frequency:		
	New:	Acqu.:	Tot.	New:	Acqu.:	Tot:	New:	Acqu.:	Tot.	New:	Acqu.:	Tot.
Agriculture	5264	73647	78911	0.10	0.13	0.13	4	11	15	0.29	0.44	0.38
Fishing & Trapping	35583	19527	55110	0.66	0.03	0.09	7	8	15	0.50	0.32	0.38
Logging	275	61120	61395	0.01	0.11	0.10	2	5	7	0.14	0.20	0.18
Mining	237310	5496446	5733756	4.37	9.59	9.14	13	55	68	0.93	2.18	1.73
Petroleum & Natural Gas	245073	11927748	12172821	4.52	20.80	19.40	31	146	177	2.21	5.78	4.51
Manufacturing	2607851	22507515	25115366	48.08	39.26	40.02	243	875	1118	17.36	34.64	28.48
Construction	402488	1721267	2123755	7.42	3.00	3.38	56	37	93	4.00	1.46	2.37
Transport. & Storage	36534	298649	335183	0.67	0.52	0.53	41	55	96	2.93	2.18	2.45
Communication & Utilities	88400	198894	287294	1.63	0.35	0.46	10	51	61	0.71	2.02	1.55
Wholesale Trade	274613	4910963	5185576	5.06	8.57	8.26	464	488	952	33.14	19.32	24.25
Retail Trade	37156	845986	883142	0.68	1.48	1.41	62	111	173	4.43	4.39	4.41
Finance & Insurance	173926	3015615	3189541	3.21	5.26	5.08	57	47	104	4.07	1.86	2.65
Real Estate & Insurance Agt	177230	2761740	2938970	3.27	4.82	4.68	42	175	217	3.00	6.93	5.53
Business Services	214504	696893	911397	3.95	1.22	1.45	231	208	439	16.50	8.23	11.18
Educational Services	3952	16929	20881	0.07	0.03	0.03	10	3	13	0.71	0.12	0.33
Health & Social Services	30200	6339	36539	0.56	0.01	0.06	2	8	10	0.14	0.32	0.25
Accommodation, Food & Bev	50811	1727936	1778747	0.94	3.01	2.83	29	116	145	2.07	4.59	3.69
Other	803311	1047296	1850607	14.81	1.83	2.95	96	127	223	6.86	5.03	5.68
Total:	5424481	57334510	62758991	100.00	100.00	100.00	1400	2526	3926	100	100	100



*World*

ATLANTIC PROVINCES:  
(including indirect and incidental investment)

Sector:	Asset Value:			% of Tot. Asset Value			Frequency:			% of Tot. Frequency:		
	New:	Acqu.:	Tot.	New:	Acqu.:	Tot:	New:	Acqu.:	Tot.	New:	Acqu.:	Tot.
Agriculture	0	1150	1150	0.00	0.22	0.11	0	1	1	0.00	1.14	0.83
Fishing & Trapping	25273	190	25463	4.94	0.04	2.45	4	1	5	12.12	1.14	4.13
Logging	25	833	858	0.00	0.16	0.08	1	1	2	3.03	1.14	1.65
Mining	55000	204073	259073	10.75	38.68	24.93	2	6	8	6.06	6.82	6.61
Petroleum & Natural Gas	126010	51705	177715	24.63	9.80	17.10	4	2	6	12.12	2.27	4.96
Manufacturing	4840	158887	163727	0.95	30.11	15.76	6	23	29	18.18	26.14	23.97
Construction	202873	0	202873	39.66	0.00	19.52	4	1	5	12.12	1.14	4.13
Transport. & Storage	0	65	65	0.00	0.01	0.01	0	1	1	0.00	1.14	0.83
Communication & Utilities	0	300	300	0.00	0.06	0.03	0	1	1	0.00	1.14	0.83
Wholesale Trade	26755	52582	79337	5.23	9.97	7.63	7	20	27	21.21	22.73	22.31
Retail Trade	0	19633	19633	0.00	3.72	1.89	0	8	8	0.00	9.09	6.61
Finance & Insurance	0	400	400	0.00	0.08	0.04	0	1	1	0.00	1.14	0.83
Real Estate & Insurance Agt	200	23552	23752	0.04	4.46	2.29	1	7	8	3.03	7.95	6.61
Business Services	70181	2225	72406	13.72	0.42	6.97	2	5	7	6.06	5.68	5.79
Educational Services	0	0	0	0.00	0.00	0.00	0	0	0	0.00	0.00	0.00
Health & Social Services	0	0	0	0.00	0.00	0.00	0	0	0	0.00	0.00	0.00
Accomodation, Food & Bev	400	340	740	0.08	0.06	0.07	1	5	6	3.03	5.68	4.96
Other	0	11672	11672	0.00	2.21	1.12	1	5	6	3.03	5.68	4.96
<b>Total:</b>	<b>511557</b>	<b>527607</b>	<b>1039164</b>	<b>100</b>	<b>100</b>	<b>100</b>	<b>33</b>	<b>88</b>	<b>121</b>	<b>100</b>	<b>100</b>	<b>100</b>

World

ATLANTIC PROVINCES:  
(direct investment only)

Sector:	Asset Value:			% of Tot. Asset Value			Frequency:			% of Tot. Frequency:		
	New:	Acqu.:	Tot.	New:	Acqu.:	Tot:	New:	Acqu.:	Tot.	New:	Acqu.:	Tot.
Agriculture	0	1150	1150	0.00	0.25	0.12	0	1	1	0.00	1.19	0.85
Fishing & Trapping	25273	190	25463	4.94	0.04	2.60	4	1	5	12.12	1.19	4.27
Logging	25	833	858	0.00	0.18	0.09	1	1	2	3.03	1.19	1.71
Mining	55000	155217	210217	10.75	33.17	21.46	2	4	6	6.06	4.76	5.13
Petroleum & Natural Gas	126010	51705	177715	24.63	11.05	18.14	4	2	6	12.12	2.38	5.13
Manufacturing	4840	154891	159731	0.95	33.10	16.31	6	22	28	18.18	26.19	23.93
Construction	202873	0	202873	39.66	0.00	20.71	4	1	5	12.12	1.19	4.27
Transport. & Storage	0	65	65	0.00	0.01	0.01	0	1	1	0.00	1.19	0.85
Communication & Utilities	0	300	300	0.00	0.06	0.03	0	1	1	0.00	1.19	0.85
Wholesale Trade	26755	45801	72556	5.23	9.79	7.41	7	19	26	21.21	22.62	22.22
Retail Trade	0	19633	19633	0.00	4.20	2.00	0	8	8	0.00	9.52	6.84
Finance & Insurance	0	400	400	0.00	0.09	0.04	0	1	1	0.00	1.19	0.85
Real Estate & Insurance Agt	200	23552	23752	0.04	5.03	2.42	1	7	8	3.03	8.33	6.84
Business Services	70181	2225	72406	13.72	0.48	7.39	2	5	7	6.06	5.95	5.98
Educational Services	0	0	0	0.00	0.00	0.00	0	0	0	0.00	0.00	0.00
Health & Social Services	0	0	0	0.00	0.00	0.00	0	0	0	0.00	0.00	0.00
Accomodation, Food & Bev	400	340	740	0.08	0.07	0.08	1	5	6	3.03	5.95	5.13
Other	0	11672	11672	0.00	2.49	1.19	1	5	6	3.03	5.95	5.13
Total:	511557	467974	979531	100.00	100.00	100.00	33	84	117	100	100	100

*World*

NEWFOUNDLAND:  
(including direct, indirect and incidental investment)

Sector:	Asset Value: (000's)			% of Tot. NFLD Asset Value			Frequency:			% of Tot. NFLD Frequency:		
	New:	Acqu.:	Tot:	New:	Acqu.:	Tot:	New:	Acqu.:	Tot:	New:	Acqu.:	Tot:
Agriculture	0	0	0	0.00	0.00	0.00	0	0	0	0.00	0.00	0.00
Fishing & Trapping	100	0	100	0.13	0.00	0.06	1	0	1	3.33	0.00	3.33
Logging	0	833	833	0.00	0.86	0.48	0	1	1	0.00	3.33	3.33
Mining	15000	1766	16766	19.28	1.81	9.68	1	1	2	3.33	3.33	6.67
Petroleum & Natural Gas	36010	51705	87715	46.29	53.09	50.66	2	2	4	6.67	6.67	13.33
Manufacturing	50	34253	34303	0.06	35.17	19.81	1	3	4	3.33	10.00	13.33
Construction	1200	0	1200	1.54	0.00	0.69	1	0	1	3.33	0.00	3.33
Transport. & Storage	0	0	0	0.00	0.00	0.00	0	0	0	0.00	0.00	0.00
Communication & Utilities	0	0	0	0.00	0.00	0.00	0	0	0	0.00	0.00	0.00
Wholesale Trade	25000	6799	31799	32.14	6.98	18.37	1	5	6	3.33	16.67	20.00
Retail Trade	0	0	0	0.00	0.00	0.00	0	3	3	0.00	10.00	10.00
Finance & Insurance	0	0	0	0.00	0.00	0.00	0	0	0	0.00	0.00	0.00
Real Estate & Insurance Agt	0	0	0	0.00	0.00	0.00	0	4	4	0.00	13.33	13.33
Business Services	180	0	180	0.23	0.00	0.10	0	2	2	0.00	6.67	6.67
Educational Services	0	0	0	0.00	0.00	0.00	0	0	0	0.00	0.00	0.00
Health & Social Services	0	0	0	0.00	0.00	0.00	0	0	0	0.00	0.00	0.00
Accomodation, Food & Bev	250	0	250	0.32	0.00	0.14	0	2	2	0.00	6.67	6.67
Other	0	2043	2043	0.00	2.10	1.18	1	3	4	3.33	10.00	13.33
Total:	77790	97399	173146	100	100	100	7	23	30	23.33	76.67	100.00

100

*World*

NEWFOUNDLAND:  
(direct investment only)

Sector:	Asset Value:			% of Tot. NFLD Asset Value			Frequency:			% of Tot. NFLD Frequency:		
	New:	Acqu.:	Tot:	New:	Acqu.:	Tot:	New:	Acqu.:	Tot:	New:	Acqu.:	Tot:
Agriculture	0	0	0	0.00	0.00	0.00	0	0	0	0.00	0.00	0.00
Fishing & Trapping	100	0	100	0.13	0.00	0.06	1	0	1	3.03	0.00	3.03
Logging	0	833	833	0.00	0.87	0.48	0	1	1	0.00	3.03	3.03
Mining	15000	0	15000	19.28	0.00	8.65	1	0	1	3.03	0.00	3.03
Petroleum & Natural Gas	36010	51705	87715	46.29	54.07	50.58	2	2	4	6.06	6.06	12.12
Manufacturing	50	34253	34303	0.06	35.82	19.78	1	3	4	3.03	9.09	12.12
Construction	1200	0	1200	1.54	0.00	0.69	1	0	1	3.03	0.00	3.03
Transport. & Storage	0	0	0	0.00	0.00	0.00	0	0	0	0.00	0.00	0.00
Communication & Utilities	0	0	0	0.00	0.00	0.00	0	0	0	0.00	0.00	0.00
Wholesale Trade	25000	6799	31799	32.14	7.11	18.34	1	5	6	3.03	15.15	18.18
Retail Trade	0	0	0	0.00	0.00	0.00	0	3	3	0.00	9.09	9.09
Finance & Insurance	0	0	0	0.00	0.00	0.00	0	0	0	0.00	0.00	0.00
Real Estate & Insurance Agt	0	0	0	0.00	0.00	0.00	0	4	4	0.00	12.12	12.12
Business Services	180	0	180	0.23	0.00	0.10	0	2	2	0.00	6.06	6.06
Educational Services	0	0	0	0.00	0.00	0.00	0	0	0	0.00	0.00	0.00
Health & Social Services	0	0	0	0.00	0.00	0.00	0	0	0	0.00	0.00	0.00
Accomodation, Food & Bev	250	0	250	0.32	0.00	0.14	0	2	2	0.00	6.06	6.06
Other	0	2043	2043	0.00	2.14	1.18	1	3	4	3.03	9.09	12.12
Total:	77790	95633	173423	100	100	100	8	25	33	24.24	75.76	100.00

World

NOVA SCOTIA:  
(including indirect and incidental investment)

Sector:	Asset Value: (000's)			% of Tot. NFLD Asset Value			Frequency:			% of Tot. Frequency:		
	New:	Acqu.:	Tot:	New:	Acqu.:	Tot:	New:	Acqu.:	Tot:	New:	Acqu.:	Tot:
Agriculture	0	1150	1150	0.00	0.37	0.23	0	1	1	0.00	1.56	1.56
Fishing & Trapping	25173	0	25173	13.00	0.00	5.01	3	0	3	4.69	0.00	4.69
Logging	25	0	25	0.01	0.00	0.00	1	0	1	1.56	0.00	1.56
Mining	0	200557	200557	0.00	64.96	39.93	0	4	4	0.00	6.25	6.25
Petroleum & Natural Gas	90000	0	90000	46.50	0.00	17.92	2	0	2	3.13	0.00	3.13
Manufacturing	4790	58463	63253	2.47	18.93	12.59	5	13	18	7.81	20.31	28.13
Construction	1673	0	1673	0.86	0.00	0.33	2	1	3	3.13	1.56	4.69
Transport. & Storage	0	65	65	0.00	0.02	0.01	0	1	1	0.00	1.56	1.56
Communication & Utilities	0	300	300	0.00	0.10	0.06	0	1	1	0.00	1.56	1.56
Wholesale Trade	1555	12294	13849	0.80	3.98	2.76	5	8	13	7.81	12.50	20.31
Retail Trade	0	186	186	0.00	0.06	0.04	0	2	2	0.00	3.13	3.13
Finance & Insurance	0	0	0	0.00	0.00	0.00	0	0	0	0.00	0.00	0.00
Real Estate & Insurance Agt	200	23552	23752	0.10	7.63	4.73	1	3	4	1.56	4.69	6.25
Business Services	70001	2225	72226	36.16	0.72	14.38	2	3	5	3.13	4.69	7.81
Educational Services	0	0	0	0.00	0.00	0.00	0	0	0	0.00	0.00	0.00
Health & Social Services	0	0	0	0.00	0.00	0.00	0	0	0	0.00	0.00	0.00
Accommodation, Food & Bev	150	340	490	0.08	0.11	0.10	1	3	4	1.56	4.69	6.25
Other	0	9629	9629	0.00	3.12	1.92	0	2	2	0.00	3.13	3.13
Total:	193567	308761	502328	100	100	100	22	42	64	34.38	65.63	100.00
								64			100	

*World*

NOVA SCOTIA:  
(direct investment only)

Sector:	Asset Value: (000's)			% of Tot. NFLD Asset Value			Frequency:			% of Tot. Frequency:		
	New:	Acqu.:	Tot:	New:	Tot:		New:	Acqu.:	Tot:	New:	Acqu.:	Tot:
Agriculture	0	1150	1150	0.00	0.45	0.25	0	1	1	0.00	1.67	1.67
Fishing & Trapping	25173	0	25173	13.00	0.00	5.58	3	0	3	5.00	0.00	5.00
Logging	25	0	25	0.01	0.00	0.01	1	0	1	1.67	0.00	1.67
Mining	0	153467	153467	0.00	59.56	34.01	0	3	3	0.00	5.00	5.00
Petroleum & Natural Gas	90000	0	90000	46.50	0.00	19.94	2	0	2	3.33	0.00	3.33
Manufacturing	4790	54467	59257	2.47	21.14	13.13	5	12	17	8.33	20.00	28.33
Construction	1673	0	1673	0.86	0.00	0.37	2	1	3	3.33	1.67	5.00
Transport. & Storage	0	65	65	0.00	0.03	0.01	0	1	1	0.00	1.67	1.67
Communication & Utilities	0	300	300	0.00	0.12	0.07	0	1	1	0.00	1.67	1.67
Wholesale Trade	1555	12294	13849	0.80	4.77	3.07	5	8	13	8.33	13.33	21.67
Retail Trade	0	186	186	0.00	0.07	0.04	0	2	2	0.00	3.33	3.33
Finance & Insurance	0	0	0	0.00	0.00	0.00	0	0	0	0.00	0.00	0.00
Real Estate & Insurance Agt	200	23552	23752	0.10	9.14	5.26	1	3	4	1.67	5.00	6.67
Business Services	70001	2225	72226	36.16	0.86	16.01	2	3	5	3.33	5.00	8.33
Educational Services	0	0	0	0.00	0.00	0.00	0	0	0	0.00	0.00	0.00
Health & Social Services	0	0	0	0.00	0.00	0.00	0	0	0	0.00	0.00	0.00
Accommodation, Food & Bev	150	340	490	0.08	0.13	0.11	1	3	4	1.67	5.00	6.67
Other	0	9629	9629	0.00	3.74	2.13	0	2	2	0.00	3.33	3.33
Total:	193567	257675	451242	100	100	100	22	38	60	36.67	63.33	100.00

World

NEW BRUNSWICK:  
(direct investment only was made)

Sector:	Asset Value: (000's)			% of Tot. N. B. Asset Value			Frequency:			% of Tot. Frequency:		
	New:	Acqu.:	Tot:	New:	Acqu.:	Tot:	New:	Acqu.:	Tot:	New:	Acqu.:	Tot:
Agriculture	0	0	0	0.00	0.00	0.00	0	0	0	0.00	0.00	0.00
Fishing & Trapping	0	190	190	0.00	0.19	0.13	0	1	1	0.00	5.56	5.56
Logging	0	0	0	0.00	0.00	0.00	0	0	0	0.00	0.00	0.00
Mining	40000	1750	41750	99.50	1.71	29.31	1	1	2	5.56	5.56	11.11
Petroleum & Natural Gas	0	0	0	0.00	0.00	0.00	0	0	0	0.00	0.00	0.00
Manufacturing	0	58274	58274	0.00	57.00	40.91	0	5	5	0.00	27.78	27.78
Construction	0	0	0	0.00	0.00	0.00	0	0	0	0.00	0.00	0.00
Transport. & Storage	0	0	0	0.00	0.00	0.00	0	0	0	0.00	0.00	0.00
Communication & Utilities	0	0	0	0.00	0.00	0.00	0	0	0	0.00	0.00	0.00
Wholesale Trade	200	22178	22378	0.50	21.69	15.71	1	5	6	5.56	27.78	33.33
Retail Trade	0	19447	19447	0.00	19.02	13.65	0	3	3	0.00	16.67	16.67
Finance & Insurance	0	400	400	0.00	0.39	0.28	0	1	1	0.00	5.56	5.56
Real Estate & Insurance Agt	0	0	0	0.00	0.00	0.00	0	0	0	0.00	0.00	0.00
Business Services	0	0	0	0.00	0.00	0.00	0	0	0	0.00	0.00	0.00
Educational Services	0	0	0	0.00	0.00	0.00	0	0	0	0.00	0.00	0.00
Health & Social Services	0	0	0	0.00	0.00	0.00	0	0	0	0.00	0.00	0.00
Accomodation, Food & Bev	0	0	0	0.00	0.00	0.00	0	0	0	0.00	0.00	0.00
Other	0	0	0	0.00	0.00	0.00	0	0	0	0.00	0.00	0.00
Total:	40200	102239	142439	100	100	100	2	16	18	11.11	88.89	100.00

*World*

PRINCE EDWARD ISLAND:

(includes direct, indirect, and incidental investment made)

Sector:	Asset Value: (000's)			% of Tot. P.E.I. Asset Value			Frequency:			% of Tot. Frequency:		
	New:	Acqu.:	Tot:	New:	Acqu.:	Tot:	New:	Acqu.:	Tot:	New:	Acqu.:	Tot:
Agriculture	0	0	0	0.00	0.00	0.00	0	0	0	0.00	0.00	0.00
Fishing & Trapping	0	0	0	0.00	0.00	0.00	0	0	0	0.00	0.00	0.00
Logging	0	0	0	0.00	0.00	0.00	0	0	0	0.00	0.00	0.00
Mining	0	0	0	0.00	0.00	0.00	0	0	0	0.00	0.00	0.00
Petroleum & Natural Gas	0	0	0	0.00	0.00	0.00	0	0	0	0.00	0.00	0.00
Manufacturing	0	7897	7897	0.00	41.11	3.60	0	2	2	0.00	40.00	40.00
Construction	200000	0	200000	100.00	0.00	91.24	1	0	1	20.00	0.00	20.00
Transport. & Storage	0	0	0	0.00	0.00	0.00	0	0	0	0.00	0.00	0.00
Communication & Utilities	0	0	0	0.00	0.00	0.00	0	0	0	0.00	0.00	0.00
Wholesale Trade	0	11311	11311	0.00	58.89	5.16	0	2	2	0.00	40.00	40.00
Retail Trade	0	0	0	0.00	0.00	0.00	0	0	0	0.00	0.00	0.00
Finance & Insurance	0	0	0	0.00	0.00	0.00	0	0	0	0.00	0.00	0.00
Real Estate & Insurance Agt	0	0	0	0.00	0.00	0.00	0	0	0	0.00	0.00	0.00
Business Services	0	0	0	0.00	0.00	0.00	0	0	0	0.00	0.00	0.00
Educational Services	0	0	0	0.00	0.00	0.00	0	0	0	0.00	0.00	0.00
Health & Social Services	0	0	0	0.00	0.00	0.00	0	0	0	0.00	0.00	0.00
Accomodation, Food & Bev	0	0	0	0.00	0.00	0.00	0	0	0	0.00	0.00	0.00
Other	0	0	0	0.00	0.00	0.00	0	0	0	0.00	0.00	0.00
Total:	200000	19208	219208	100	100	100	1	4	5	20.00	80.00	100.00



*World*

PRINCE EDWARD ISLAND:  
(direct investment only)

Sector:	Asset Value: (000's)			% of Tot. P.E.I. Asset Value			Frequency:			% of Tot. Frequency:		
	New:	Acqu.:	Tot:	New:	Acqu.:	Tot:	New:	Acqu.:	Tot:	New:	Acqu.:	Tot:
Agriculture	0	0	0	0.00	0.00	0.00	0	0	0	0.00	0.00	0.00
Fishing & Trapping	0	0	0	0.00	0.00	0.00	0	0	0	0.00	0.00	0.00
Logging	0	0	0	0.00	0.00	0.00	0	0	0	0.00	0.00	0.00
Mining	0	0	0	0.00	0.00	0.00	0	0	0	0.00	0.00	0.00
Petroleum & Natural Gas	0	0	0	0.00	0.00	0.00	0	0	0	0.00	0.00	0.00
Manufacturing	0	7897	7897	0.00	63.55	3.72	0	2	2	0.00	50.00	50.00
Construction	200000	0	200000	100.00	0.00	94.15	1	0	1	25.00	0.00	25.00
Transport. & Storage	0	0	0	0.00	0.00	0.00	0	0	0	0.00	0.00	0.00
Communication & Utilities	0	0	0	0.00	0.00	0.00	0	0	0	0.00	0.00	0.00
Wholesale Trade	0	4530	4530	0.00	36.45	2.13	0	1	1	0.00	25.00	25.00
Retail Trade	0	0	0	0.00	0.00	0.00	0	0	0	0.00	0.00	0.00
Finance & Insurance	0	0	0	0.00	0.00	0.00	0	0	0	0.00	0.00	0.00
Real Estate & Insurance Agt	0	0	0	0.00	0.00	0.00	0	0	0	0.00	0.00	0.00
Business Services	0	0	0	0.00	0.00	0.00	0	0	0	0.00	0.00	0.00
Educational Services	0	0	0	0.00	0.00	0.00	0	0	0	0.00	0.00	0.00
Health & Social Services	0	0	0	0.00	0.00	0.00	0	0	0	0.00	0.00	0.00
Accommodation, Food & Bev	0	0	0	0.00	0.00	0.00	0	0	0	0.00	0.00	0.00
Other	0	0	0	0.00	0.00	0.00	0	0	0	0.00	0.00	0.00
Total:	200000	12427	212427	100	100	100	1	3	4	25.00	75.00	100.00

*World*

QUEBEC:  
(including indirect and incidental investment)

Sector:	Asset Value: (000's)			% of Tot. QUE Asset Value			Frequency:			% of Tot. Frequency:		
	New:	Acqu.:	Tot:	New:	Acqu.:	Tot:	New:	Acqu.:	Tot:	New:	Acqu.:	Tot:
Agriculture	1264	21430	22694	0.06	0.15	0.14	1	3	4	0.16	0.48	0.64
Fishing & Trapping	50	0	50	0.00	0.00	0.00	1	0	1	0.16	0.00	0.16
Logging	0	0	0	0.00	0.00	0.00	0	0	0	0.00	0.00	0.00
Mining	1010	1295266	1296276	0.05	9.32	8.14	2	6	8	0.32	0.95	1.27
Petroleum & Natural Gas	1	0	1	0.00	0.00	0.00	1	0	1	0.16	0.00	0.16
Manufacturing	1834109	9200286	11034395	90.82	66.21	69.33	45	176	221	7.15	27.98	35.14
Construction	55010	17009	72019	2.72	0.12	0.45	7	6	13	1.11	0.95	2.07
Transport. & Storage	2365	50465	52830	0.12	0.36	0.33	6	15	21	0.95	2.38	3.34
Communication & Utilities	0	15233	15233	0.00	0.11	0.10	0	10	10	0.00	1.59	1.59
Wholesale Trade	40865	1305207	1346072	2.02	9.39	8.46	68	109	177	10.81	17.33	28.14
Retail Trade	3440	388213	391653	0.17	2.79	2.46	15	20	35	2.38	3.18	5.56
Finance & Insurance	49921	542958	592879	2.47	3.91	3.73	10	5	15	1.59	0.79	2.38
Real Estate & Insurance Agt	10501	115124	125625	0.52	0.83	0.79	3	9	12	0.48	1.43	1.91
Business Services	9388	146475	155863	0.46	1.05	0.98	32	35	67	5.09	5.56	10.65
Educational Services	0	0	0	0.00	0.00	0.00	0	0	0	0.00	0.00	0.00
Health & Social Services	0	700	700	0.00	0.01	0.00	0	1	1	0.00	0.16	0.16
Accomodation, Food & Bev	0	262198	262198	0.00	1.89	1.65	0	14	14	0.00	2.23	2.23
Other	11630	535582	547212	0.58	3.85	3.44	9	20	29	1.43	3.18	4.61
<b>Total:</b>	<b>2019554</b>	<b>13896146</b>	<b>15915700</b>	<b>100</b>	<b>100</b>	<b>100</b>	<b>200</b>	<b>429</b>	<b>629</b>	<b>31.80</b>	<b>68.20</b>	<b>100.00</b>
							<b>629</b>				<b>100</b>	

*World*

QUEBEC:  
(direct investment only)

Sector:	Asset Value: (000's)			% of Tot. QUE Asset Value			Frequency:			% of Tot. Frequency:		
	New:	Acqu.:	Tot:	New:	Tot:		New:	Acqu.:	Tot:	New:	Acqu.:	Tot:
Agriculture	1264	17672	18936	0.06	0.17	0.15	1	2	3	0.19	0.38	0.57
Fishing & Trapping	50	0	50	0.00	0.00	0.00	1	0	1	0.19	0.00	0.19
Logging	0	0	0	0.00	0.00	0.00	0	0	0	0.00	0.00	0.00
Mining	1010	1247297	1248307	0.05	11.89	9.98	2	4	6	0.38	0.75	1.13
Petroleum & Natural Gas	1	0	1	0.00	0.00	0.00	1	0	1	0.19	0.00	0.19
Manufacturing	1834109	6656402	8490511	90.82	63.43	67.85	45	140	185	8.49	26.42	34.91
Construction	55010	16813	71823	2.72	0.16	0.57	7	5	12	1.32	0.94	2.26
Transport. & Storage	2365	43865	46230	0.12	0.42	0.37	6	14	20	1.13	2.64	3.77
Communication & Utilities	0	15233	15233	0.00	0.15	0.12	0	10	10	0.00	1.89	1.89
Wholesale Trade	40865	1099341	1140206	2.02	10.48	9.11	68	94	162	12.83	17.74	30.57
Retail Trade	3440	369224	372664	0.17	3.52	2.98	15	17	32	2.83	3.21	6.04
Finance & Insurance	49921	521344	571265	2.47	4.97	4.56	10	4	14	1.89	0.75	2.64
Real Estate & Insurance Agt	10501	115124	125625	0.52	1.10	1.00	3	9	12	0.57	1.70	2.26
Business Services	9388	128902	138290	0.46	1.23	1.11	32	29	61	6.04	5.47	11.51
Educational Services	0	0	0	0.00	0.00	0.00	0	0	0	0.00	0.00	0.00
Health & Social Services	0	700	700	0.00	0.01	0.01	0	1	1	0.00	0.19	0.19
Accomodation, Food & Bev	0	123646	123646	0.00	1.18	0.99	0	10	10	0.00	1.89	1.89
Other	11630	139134	150764	0.58	1.33	1.20	9	13	22	1.70	2.45	4.15
<b>Total:</b>	<b>2019554</b>	<b>10494697</b>	<b>12514251</b>	<b>100</b>	<b>100</b>	<b>100</b>	<b>200</b>	<b>352</b>	<b>552</b>	<b>36.04</b>	<b>63.96</b>	<b>100.00</b>

*World*

ONTARIO:  
(including direct, indirect and incidental investment)

Sector:	Asset Value: (000's)			% of Tot. ONT Asset Value			Frequency:			% of Tot. ONT Frequency:		
	New:	Acqu.:	Tot:	New:	Acqu.:	Tot:	New:	Acqu.:	Tot:	New:	Acqu.:	Tot:
Agriculture	250	70696	70946	0.02	0.16	0.15	1	5	6	0.04	0.18	0.22
Fishing & Trapping	0	0	0	0.00	0.00	0.00	0	0	0	0.00	0.00	0.00
Logging	0	0	0	0.00	0.00	0.00	0	0	0	0.00	0.00	0.00
Mining	12900	3225126	3238026	0.80	7.25	7.03	5	24	29	0.18	0.87	1.05
Petroleum & Natural Gas	0	3938347	3938347	0.00	8.86	8.55	0	7	7	0.00	0.25	0.25
Manufacturing	235019	23786932	24021951	14.58	53.49	52.13	141	917	1058	5.08	33.07	38.15
Construction	4143	1701117	1705260	0.26	3.83	3.70	16	21	37	0.58	0.76	1.33
Transport. & Storage	12081	136066	148147	0.75	0.31	0.32	20	19	39	0.72	0.69	1.41
Communication & Utilities	82900	40133	123033	5.14	0.09	0.27	7	27	34	0.25	0.97	1.23
Wholesale Trade	171293	2312467	2483760	10.63	5.20	5.39	331	378	709	11.94	13.63	25.57
Retail Trade	17833	423993	441826	1.11	0.95	0.96	34	72	106	1.23	2.60	3.82
Finance & Insurance	122205	3104293	3226498	7.58	6.98	7.00	40	43	83	1.44	1.55	2.99
Real Estate & Insurance Agt	84882	2080780	2165662	5.27	4.68	4.70	23	71	94	0.83	2.56	3.39
Business Services	74773	763200	837973	4.64	1.72	1.82	152	162	314	5.48	5.84	11.32
Educational Services	1300	41224	42524	0.08	0.09	0.09	7	4	11	0.25	0.14	0.40
Health & Social Services	200	24740	24940	0.01	0.06	0.05	1	12	13	0.04	0.43	0.47
Accomodation, Food & Bev	37065	1031170	1068235	2.30	2.32	2.32	14	58	72	0.50	2.09	2.60
Other	754849	1791134	2545983	46.84	4.03	5.52	61	100	161	2.20	3.61	5.81
<b>Total:</b>	<b>1611693</b>	<b>44471418</b>	<b>46083111</b>	<b>100</b>	<b>100</b>	<b>94.47524</b>	<b>853</b>	<b>1920</b>	<b>2773</b>	<b>30.76</b>	<b>69.24</b>	<b>100.00</b>

100

World

ONTARIO:  
(direct investment only)

Sector:	Asset Value:			% of Tot. ONT Asset Value			Frequency:			% of Tot. ONT Frequency:		
	New:	Acqu.:	Tot:	New:	Acqu.:	Tot:	New:	Acqu.:	Tot:	New:	Acqu.:	Tot:
Agriculture	250	44480	44730	0.02	0.16	0.15	1	3	4	0.05	0.14	0.18
Fishing & Trapping	0	0	0	0.00	0.00	0.00	0	0	0	0.00	0.00	0.00
Logging	0	0	0	0.00	0.00	0.00	0	0	0	0.00	0.00	0.00
Mining	12900	2889814	2902714	0.80	10.41	9.88	5	22	27	0.23	1.01	1.24
Petroleum & Natural Gas	0	3907623	3907623	0.00	14.08	13.31	0	6	6	0.00	0.28	0.28
Manufacturing	235019	11911923	12146942	14.58	42.92	41.36	141	557	698	6.48	25.60	32.08
Construction	4143	1685775	1689918	0.26	6.07	5.75	16	19	35	0.74	0.87	1.61
Transport. & Storage	12081	112528	124609	0.75	0.41	0.42	20	14	34	0.92	0.64	1.56
Communication & Utilities	82900	29318	112218	5.14	0.11	0.38	7	25	32	0.32	1.15	1.47
Wholesale Trade	171293	1321268	1492561	10.63	4.76	5.08	331	256	587	15.21	11.76	26.98
Retail Trade	17833	284795	302628	1.11	1.03	1.03	34	62	96	1.56	2.85	4.41
Finance & Insurance	122205	2177720	2299925	7.58	7.85	7.83	40	30	70	1.84	1.38	3.22
Real Estate & Insurance Agt	84882	1205767	1290649	5.27	4.34	4.39	23	64	87	1.06	2.94	4.00
Business Services	74773	424116	498889	4.64	1.53	1.70	152	126	278	6.99	5.79	12.78
Educational Services	1300	16446	17746	0.08	0.06	0.06	7	2	9	0.32	0.09	0.41
Health & Social Services	200	5639	5839	0.01	0.02	0.02	1	7	8	0.05	0.32	0.37
Accomodation, Food & Bev	37065	937667	974732	2.30	3.38	3.32	14	51	65	0.64	2.34	2.99
Other	754849	801960	1556809	46.84	2.89	5.30	61	79	140	2.80	3.63	6.43
Total:	1611693	27756839	29368532	100	100	100	853	1323	2176	39.20	60.80	100.00

World

PRAIRIE PROVINCES:  
(including indirect and incidental investment)

Sector:	Asset Value:			% of Tot. Asset Value			Frequency:			% of Tot. Frequency:		
	New:	Acqu.:	Tot.	New:	Acqu.:	Tot:	New:	Acqu.:	Tot.	New:	Acqu.:	Tot.
Agriculture	3750	7419	11169	0.45	0.05	0.07	2	2	4	1.35	0.43	0.66
Fishing & Trapping	0	970	970	0.00	0.01	0.01	0	1	1	0.00	0.22	0.16
Logging	0	45731	45731	0.00	0.28	0.27	0	2	2	0.00	0.43	0.33
Mining	166150	933234	1099384	19.78	5.72	6.41	2	9	11	1.35	1.95	1.81
Petroleum & Natural Gas	114529	9972974	10087503	13.64	61.17	58.84	25	146	171	16.89	31.67	28.08
Manufacturing	425003	1766561	2191564	50.61	10.83	12.78	26	99	125	17.57	21.48	20.53
Construction	9802	62706	72508	1.17	0.38	0.42	5	9	14	3.38	1.95	2.30
Transport. & Storage	7991	99780	107771	0.95	0.61	0.63	4	12	16	2.70	2.60	2.63
Communication & Utilities	500	10322	10822	0.06	0.06	0.06	2	9	11	1.35	1.95	1.81
Wholesale Trade	26214	1278809	1305023	3.12	7.84	7.61	29	75	104	19.59	16.27	17.08
Retail Trade	1603	1100142	1101745	0.19	6.75	6.43	4	14	18	2.70	3.04	2.96
Finance & Insurance	1450	204497	205947	0.17	1.25	1.20	6	8	14	4.05	1.74	2.30
Real Estate & Insurance Agt	9197	652428	661625	1.10	4.00	3.86	6	23	29	4.05	4.99	4.76
Business Services	31699	55919	87618	3.77	0.34	0.51	23	31	54	15.54	6.72	8.87
Educational Services	5	0	5	0.00	0.00	0.00	1	0	1	0.68	0.00	0.16
Health & Social Services	30000	0	30000	3.57	0.00	0.17	1	0	1	0.68	0.00	0.16
Accomodation, Food & Bev	700	93721	94421	0.08	0.57	0.55	3	13	16	2.03	2.82	2.63
Other	11220	19154	30374	1.34	0.12	0.18	9	8	17	6.08	1.74	2.79
Total:	839813	16304367	17144180	100	100	100	148	461	609	100	100	100

*World*

PRAIRIE PROVINCES:  
(direct investment only)

Sector:	Asset Value:			% of Tot. Asset Value			Frequency:			% of Tot. Frequency:		
	New:	Acqu.:	Tot.	New:	Acqu.:	Tot:	New:	Acqu.:	Tot.	New:	Acqu.:	Tot.
Agriculture	3750	3440	7190	0.45	0.03	0.05	2	1	3	1.35	0.25	0.55
Fishing & Trapping	0	970	970	0.00	0.01	0.01	0	1	1	0.00	0.25	0.18
Logging	0	45731	45731	0.00	0.36	0.34	0	2	2	0.00	0.50	0.36
Mining	166150	746203	912353	19.78	5.93	6.80	2	7	9	1.35	1.75	1.64
Petroleum & Natural Gas	114529	7966275	8080804	13.64	63.30	60.19	25	133	158	16.89	33.25	28.83
Manufacturing	425003	1536225	1961228	50.61	12.21	14.61	26	82	108	17.57	20.50	19.71
Construction	9802	10014	19816	1.17	0.08	0.15	5	6	11	3.38	1.50	2.01
Transport. & Storage	7991	63702	71693	0.95	0.51	0.53	4	10	14	2.70	2.50	2.55
Communication & Utilities	500	9473	9973	0.06	0.08	0.07	2	8	10	1.35	2.00	1.82
Wholesale Trade	26214	1176289	1202503	3.12	9.35	8.96	29	64	93	19.59	16.00	16.97
Retail Trade	1603	100142	101745	0.19	0.80	0.76	4	13	17	2.70	3.25	3.10
Finance & Insurance	1450	201968	203418	0.17	1.60	1.52	6	7	13	4.05	1.75	2.37
Real Estate & Insurance Agt	9197	575428	584625	1.10	4.57	4.35	6	22	28	4.05	5.50	5.11
Business Services	31699	38632	70331	3.77	0.31	0.52	23	24	47	15.54	6.00	8.58
Educational Services	5	0	5	0.00	0.00	0.00	1	0	1	0.68	0.00	0.18
Health & Social Services	30000	0	30000	3.57	0.00	0.22	1	0	1	0.68	0.00	0.18
Accomodation, Food & Bev	700	93721	94421	0.08	0.74	0.70	3	13	16	2.03	3.25	2.92
Other	11220	17154	28374	1.34	0.14	0.21	9	7	16	6.08	1.75	2.92
Total:	839813	12585367	13425180	100.00	100.00	100.00	148	400	548	100	100	100

*World*

MANITOBA:  
(including direct, indirect and incidental investment)

Sector:	Asset Value: (000's)			% of Tot. MTB Asset Value			Frequency:			% of Tot. MTB Frequency:		
	New:	Acqu.:	Tot:	New:	Acqu.:	Tot:	New:	Acqu.:	Tot:	New:	Acqu.:	Tot:
Agriculture	0	7419	7419	0.00	0.85	0.82	0	2	2	0.00	2.60	2.60
Fishing & Trapping	0	0	0	0.00	0.00	0.00	0	0	0	0.00	0.00	0.00
Logging	0	0	0	0.00	0.00	0.00	0	0	0	0.00	0.00	0.00
Mining	0	129411	129411	0.00	14.78	14.39	0	1	1	0.00	1.30	1.30
Petroleum & Natural Gas	0	0	0	0.00	0.00	0.00	0	0	0	0.00	0.00	0.00
Manufacturing	13115	450456	463571	53.24	51.45	51.54	8	25	33	10.39	32.47	42.86
Construction	0	3129	3129	0.00	0.36	0.35	0	2	2	0.00	2.60	2.60
Transport. & Storage	6500	310	6810	26.39	0.04	0.76	1	1	2	1.30	1.30	2.60
Communication & Utilities	0	0	0	0.00	0.00	0.00	0	0	0	0.00	0.00	0.00
Wholesale Trade	350	221381	221731	1.42	25.28	24.65	3	20	23	3.90	25.97	29.87
Retail Trade	1000	7945	8945	4.06	0.91	0.99	1	3	4	1.30	3.90	5.19
Finance & Insurance	0	0	0	0.00	0.00	0.00	0	0	0	0.00	0.00	0.00
Real Estate & Insurance Agt	0	54414	54414	0.00	6.21	6.05	0	4	4	0.00	5.19	5.19
Business Services	3500	38	3538	14.21	0.00	0.39	1	2	3	1.30	2.60	3.90
Educational Services	0	0	0	0.00	0.00	0.00	0	0	0	0.00	0.00	0.00
Health & Social Services	0	0	0	0.00	0.00	0.00	0	0	0	0.00	0.00	0.00
Accommodation, Food & Bev	100	350	450	0.41	0.04	0.05	1	2	3	1.30	2.60	3.90
Other	70	753	823	0.28	0.09	0.09	1	3	4	1.30	3.90	5.19
Total:	24635	875606	899418	100	100	100	15	62	77	19.48	80.52	100.00

100



*World*

MANITOBA:  
(direct investment only)

Sector:	Asset Value:			% of Tot. MTB Asset Value			Frequency:			% of Tot. MTB Frequency:		
	New:	Acqu.:	Tot:	New:	Acqu.:	Tot:	New:	Acqu.:	Tot:	New:	Acqu.:	Tot:
Agriculture	0	3440	3440	0.00	0.42	0.40	0	1	1	0.00	1.41	1.41
Fishing & Trapping	0	0	0	0.00	0.00	0.00	0	0	0	0.00	0.00	0.00
Logging	0	0	0	0.00	0.00	0.00	0	0	0	0.00	0.00	0.00
Mining	0	129411	129411	0.00	15.66	15.20	0	1	1	0.00	1.41	1.41
Petroleum & Natural Gas	0	0	0	0.00	0.00	0.00	0	0	0	0.00	0.00	0.00
Manufacturing	13115	429074	442189	53.24	51.91	51.95	8	20	28	11.27	28.17	39.44
Construction	0	3129	3129	0.00	0.38	0.37	0	2	2	0.00	2.82	2.82
Transport. & Storage	6500	310	6810	26.39	0.04	0.80	1	1	2	1.41	1.41	2.82
Communication & Utilities	0	0	0	0.00	0.00	0.00	0	0	0	0.00	0.00	0.00
Wholesale Trade	350	197724	198074	1.42	23.92	23.27	3	16	19	4.23	22.54	26.76
Retail Trade	1000	7945	8945	4.06	0.96	1.05	1	3	4	1.41	4.23	5.63
Finance & Insurance	0	0	0	0.00	0.00	0.00	0	0	0	0.00	0.00	0.00
Real Estate & Insurance Agt	0	54414	54414	0.00	6.58	6.39	0	4	4	0.00	5.63	5.63
Business Services	3500	38	3538	14.21	0.00	0.42	1	2	3	1.41	2.82	4.23
Educational Services	0	0	0	0.00	0.00	0.00	0	0	0	0.00	0.00	0.00
Health & Social Services	0	0	0	0.00	0.00	0.00	0	0	0	0.00	0.00	0.00
Accommodation, Food & Bev	100	350	450	0.41	0.04	0.05	1	2	3	1.41	2.82	4.23
Other	70	753	823	0.28	0.09	0.10	1	3	4	1.41	4.23	5.63
Total:	24635	826588	851223	100	100	100	16	55	71	22.54	77.46	100.00

*World*

SASKATCHEWAN:  
(including indirect and incidental investment)

Sector:	Asset Value: (000's)			% of Tot. SASK Asset Value			Frequency:			% of Tot. Frequency:		
	New:	Acqu.:	Tot:	New:	Acqu.:	Tot:	New:	Acqu.:	Tot:	New:	Acqu.:	Tot:
Agriculture	250	0	250	1.03	0.00	0.02	1	0	1	2.27	0.00	2.27
Fishing & Trapping	0	0	0	0.00	0.00	0.00	0	0	0	0.00	0.00	0.00
Logging	0	0	0	0.00	0.00	0.00	0	0	0	0.00	0.00	0.00
Mining	0	723711	723711	0.00	53.39	52.45	0	4	4	0.00	9.09	9.09
Petroleum & Natural Gas	0	509488	509488	0.00	37.59	36.93	0	11	11	0.00	25.00	25.00
Manufacturing	6981	11754	18735	28.79	0.87	1.36	3	5	8	6.82	11.36	18.18
Construction	0	0	0	0.00	0.00	0.00	0	0	0	0.00	0.00	0.00
Transport. & Storage	1000	2569	3569	4.12	0.19	0.26	1	1	2	2.27	2.27	4.55
Communication & Utilities	0	849	849	0.00	0.06	0.06	0	1	1	0.00	2.27	2.27
Wholesale Trade	15500	33779	49279	63.91	2.49	3.57	2	7	9	4.55	15.91	20.45
Retail Trade	0	9247	9247	0.00	0.68	0.67	0	2	2	0.00	4.55	4.55
Finance & Insurance	0	63652	63652	0.00	4.70	4.61	0	1	1	0.00	2.27	2.27
Real Estate & Insurance Agt	0	50	50	0.00	0.00	0.00	0	1	1	0.00	2.27	2.27
Business Services	520	365	885	2.14	0.03	0.06	2	2	4	4.55	4.55	9.09
Educational Services	0	0	0	0.00	0.00	0.00	0	0	0	0.00	0.00	0.00
Health & Social Services	0	0	0	0.00	0.00	0.00	0	0	0	0.00	0.00	0.00
Accomodation, Food & Bev	0	0	0	0.00	0.00	0.00	0	0	0	0.00	0.00	0.00
Other	0	0	0	0.00	0.00	0.00	0	0	0	0.00	0.00	0.00
<b>Total:</b>	<b>24251</b>	<b>1355464</b>	<b>1379715</b>	<b>100</b>	<b>100</b>	<b>100</b>	<b>9</b>	<b>35</b>	<b>44</b>	<b>20.45</b>	<b>79.55</b>	<b>100.00</b>
								<b>44</b>			<b>100</b>	

*World*

SASKATCHEWAN:  
(direct investment only)

Sector:	Asset Value: (000's)			% of Tot. SASK Asset Value			Frequency:			% of Tot. Frequency:		
	New:	Acqu.:	Tot:	New:	Tot:		New:	Acqu.:	Tot:	New:	Acqu.:	Tot:
Agriculture	250	0	250	1.03	0.00	0.02	1	0	1	2.50	0.00	2.50
Fishing & Trapping	0	0	0	0.00	0.00	0.00	0	0	0	0.00	0.00	0.00
Logging	0	0	0	0.00	0.00	0.00	0	0	0	0.00	0.00	0.00
Mining	0	543717	543717	0.00	47.54	46.56	0	3	3	0.00	7.50	7.50
Petroleum & Natural Gas	0	509488	509488	0.00	44.55	43.62	0	11	11	0.00	27.50	27.50
Manufacturing	6981	7628	14609	28.79	0.67	1.25	3	4	7	7.50	10.00	17.50
Construction	0	0	0	0.00	0.00	0.00	0	0	0	0.00	0.00	0.00
Transport. & Storage	1000	2569	3569	4.12	0.22	0.31	1	1	2	2.50	2.50	5.00
Communication & Utilities	0	0	0	0.00	0.00	0.00	0	0	0	0.00	0.00	0.00
Wholesale Trade	15500	6914	22414	63.91	0.60	1.92	2	6	8	5.00	15.00	20.00
Retail Trade	0	9247	9247	0.00	0.81	0.79	0	2	2	0.00	5.00	5.00
Finance & Insurance	0	63652	63652	0.00	5.57	5.45	0	1	1	0.00	2.50	2.50
Real Estate & Insurance Agt	0	50	50	0.00	0.00	0.00	0	1	1	0.00	2.50	2.50
Business Services	520	365	885	2.14	0.03	0.08	2	2	4	5.00	5.00	10.00
Educational Services	0	0	0	0.00	0.00	0.00	0	0	0	0.00	0.00	0.00
Health & Social Services	0	0	0	0.00	0.00	0.00	0	0	0	0.00	0.00	0.00
Accomodation, Food & Bev	0	0	0	0.00	0.00	0.00	0	0	0	0.00	0.00	0.00
Other	0	0	0	0.00	0.00	0.00	0	0	0	0.00	0.00	0.00
<b>Total:</b>	<b>24251</b>	<b>1143630</b>	<b>1167881</b>	<b>100</b>	<b>100</b>	<b>100</b>	<b>9</b>	<b>31</b>	<b>40</b>	<b>22.50</b>	<b>77.50</b>	<b>100.00</b>

World

ALBERTA:

(includes direct, indirect and incidental investment made)

Sector:	Asset Value: (000's)			% of Tot. ALBT Asset Value			Frequency:			% of Tot. Frequency:		
	New:	Acqu.:	Tot:	New:	Acqu.:	Tot:	New:	Acqu.:	Tot:	New:	Acqu.:	Tot:
Agriculture	3500	0	3500	0.44	0.00	0.02	1	0	1	0.21	0.00	0.21
Fishing & Trapping	0	970	970	0.00	0.01	0.01	0	1	1	0.00	0.21	0.21
Logging	0	45731	45731	0.00	0.32	0.31	0	2	2	0.00	0.41	0.41
Mining	166150	80112	246262	21.01	0.57	1.66	2	4	6	0.41	0.83	1.24
Petroleum & Natural Gas	114529	9463486	9578015	14.48	67.24	64.44	25	135	160	5.17	27.89	33.06
Manufacturing	404907	1304351	1709258	51.19	9.27	11.50	15	69	84	3.10	14.26	17.36
Construction	9802	59577	69379	1.24	0.42	0.47	5	7	12	1.03	1.45	2.48
Transport. & Storage	491	96901	97392	0.06	0.69	0.66	2	10	12	0.41	2.07	2.48
Communication & Utilities	500	9473	9973	0.06	0.07	0.07	2	8	10	0.41	1.65	2.07
Wholesale Trade	10364	1023649	1034013	1.31	7.27	6.96	24	48	72	4.96	9.92	14.88
Retail Trade	603	1082950	1083553	0.08	7.70	7.29	3	9	12	0.62	1.86	2.48
Finance & Insurance	1450	140845	142295	0.18	1.00	0.96	6	7	13	1.24	1.45	2.69
Real Estate & Insurance Agt	9197	597964	607161	1.16	4.25	4.08	6	18	24	1.24	3.72	4.96
Business Services	27679	55516	83195	3.50	0.39	0.56	20	27	47	4.13	5.58	9.71
Educational Services	5	0	5	0.00	0.00	0.00	1	0	1	0.21	0.00	0.21
Health & Social Services	30000	0	30000	3.79	0.00	0.20	1	0	1	0.21	0.00	0.21
Accomodation, Food & Bev	600	93371	93971	0.08	0.66	0.63	2	11	13	0.41	2.27	2.69
Other	11150	18401	29551	1.41	0.13	0.20	8	5	13	1.65	1.03	2.69
Total:	790927	14073297	14864224	100	100	100	123	361	484	25.41	74.59	100.00

*World*

ALBERTA:  
(direct investment only)

Sector:	Asset Value: (000's)			% of Tot. ALBT. Asset Value			Frequency:			% of Tot. Frequency:		
	New:	Acqu.:	Tot:	New:	Acqu.:	Tot:	New:	Acqu.:	Tot:	New:	Acqu.:	Tot:
Agriculture	3500	0	3500	0.44	0.00	0.03	1	0	1	0.23	0.00	0.23
Fishing & Trapping	0	970	970	0.00	0.01	0.01	0	1	1	0.00	0.23	0.23
Logging	0	45731	45731	0.00	0.43	0.40	0	2	2	0.00	0.46	0.46
Mining	166150	73075	239225	21.01	0.69	2.10	2	3	5	0.46	0.69	1.14
Petroleum & Natural Gas	114529	7456787	7571316	14.48	70.25	66.38	25	122	147	5.72	27.92	33.64
Manufacturing	404907	1099523	1504430	51.19	10.36	13.19	15	58	73	3.43	13.27	16.70
Construction	9802	6885	16687	1.24	0.06	0.15	5	4	9	1.14	0.92	2.06
Transport. & Storage	491	60823	61314	0.06	0.57	0.54	2	8	10	0.46	1.83	2.29
Communication & Utilities	500	9473	9973	0.06	0.09	0.09	2	8	10	0.46	1.83	2.29
Wholesale Trade	10364	971651	982015	1.31	9.15	8.61	24	42	66	5.49	9.61	15.10
Retail Trade	603	82950	83553	0.08	0.78	0.73	3	8	11	0.69	1.83	2.52
Finance & Insurance	1450	138316	139766	0.18	1.30	1.23	6	6	12	1.37	1.37	2.75
Real Estate & Insurance Agt	9197	520964	530161	1.16	4.91	4.65	6	17	23	1.37	3.89	5.26
Business Services	27679	38229	65908	3.50	0.36	0.58	20	20	40	4.58	4.58	9.15
Educational Services	5	0	5	0.00	0.00	0.00	1	0	1	0.23	0.00	0.23
Health & Social Services	30000	0	30000	3.79	0.00	0.26	1	0	1	0.23	0.00	0.23
Accomodation, Food & Bev	600	93371	93971	0.08	0.88	0.82	2	11	13	0.46	2.52	2.97
Other	11150	16401	27551	1.41	0.15	0.24	8	4	12	1.83	0.92	2.75
<b>Total:</b>	<b>790927</b>	<b>10615149</b>	<b>11406076</b>	<b>100</b>	<b>100</b>	<b>100</b>	<b>123</b>	<b>314</b>	<b>437</b>	<b>28.15</b>	<b>71.85</b>	<b>100.00</b>

*World*

BRITISH COLUMBIA:

(includes direct, indirect and incidental investment made)

Sector:	Asset Value: (000's)			% of Tot. B.C. Asset Value			Frequency:			% of Tot. Frequency:		
	New:	Acqu.:	Tot:	New:	Acqu.:	Tot:	New:	Acqu.:	Tot:	New:	Acqu.:	Tot:
Agriculture	0	6905	6905	0.00	0.10	0.10	0	4	4	0.00	0.72	0.72
Fishing & Trapping	10260	18367	28627	2.33	0.27	0.40	2	6	8	0.36	1.08	1.44
Logging	250	14556	14806	0.06	0.22	0.21	1	2	3	0.18	0.36	0.54
Mining	1750	233799	235549	0.40	3.46	3.28	1	15	16	0.18	2.69	2.87
Petroleum & Natural Gas	4533	2145	6678	1.03	0.03	0.09	1	5	6	0.18	0.90	1.08
Manufacturing	108880	2676931	2785811	24.73	39.66	38.74	25	84	109	4.49	15.08	19.57
Construction	130160	50961	181121	29.56	0.75	2.52	23	7	30	4.13	1.26	5.39
Transport. & Storage	14097	105031	119128	3.20	1.56	1.66	11	19	30	1.97	3.41	5.39
Communication & Utilities	5000	144570	149570	1.14	2.14	2.08	1	7	8	0.18	1.26	1.44
Wholesale Trade	8886	1309858	1318744	2.02	19.41	18.34	28	61	89	5.03	10.95	15.98
Retail Trade	14280	219192	233472	3.24	3.25	3.25	9	12	21	1.62	2.15	3.77
Finance & Insurance	350	114183	114533	0.08	1.69	1.59	1	5	6	0.18	0.90	1.08
Real Estate & Insurance Agt	72450	841869	914319	16.46	12.47	12.72	9	73	82	1.62	13.11	14.72
Business Services	28463	113599	142062	6.46	1.68	1.98	22	26	48	3.95	4.67	8.62
Educational Services	2647	483	3130	0.60	0.01	0.04	2	1	3	0.36	0.18	0.54
Health & Social Services	0	0	0	0.00	0.00	0.00	0	0	0	0.00	0.00	0.00
Accomodation, Food & Bev	12646	814050	826696	2.87	12.06	11.50	11	42	53	1.97	7.54	9.52
Other	25612	83597	109209	5.82	1.24	1.52	16	25	41	2.87	4.49	7.36
<b>Total:</b>	<b>440264</b>	<b>6750096</b>	<b>7190360</b>	<b>100</b>	<b>100</b>	<b>100</b>	<b>163</b>	<b>394</b>	<b>557</b>	<b>29.26</b>	<b>70.74</b>	<b>100.00</b>

World

BRITISH COLUMBIA:  
(direct investment only)

Sector:	Asset Value: (000's)			% of Tot. B.C. Asset Value			Frequency:			% of Tot. Frequency:		
	New:	Acqu.:	Tot:	New:	Acqu.:	Tot:	New:	Acqu.:	Tot:	New:	Acqu.:	Tot:
Agriculture	0	6905	6905	0.00	0.12	0.11	0	4	4	0.00	0.76	0.76
Fishing & Trapping	10260	18367	28627	2.33	0.33	0.47	2	6	8	0.38	1.15	1.53
Logging	250	14556	14806	0.06	0.26	0.24	1	2	3	0.19	0.38	0.57
Mining	1750	137149	138899	0.40	2.43	2.28	1	12	13	0.19	2.29	2.49
Petroleum & Natural Gas	4533	2145	6678	1.03	0.04	0.11	1	5	6	0.19	0.96	1.15
Manufacturing	108880	2248074	2356954	24.73	39.81	38.72	25	74	99	4.78	14.15	18.93
Construction	130160	8665	138825	29.56	0.15	2.28	23	6	29	4.40	1.15	5.54
Transport. & Storage	14097	78489	92586	3.20	1.39	1.52	11	16	27	2.10	3.06	5.16
Communication & Utilities	5000	144570	149570	1.14	2.56	2.46	1	7	8	0.19	1.34	1.53
Wholesale Trade	8886	1268264	1277150	2.02	22.46	20.98	28	55	83	5.35	10.52	15.87
Retail Trade	14280	72192	86472	3.24	1.28	1.42	9	11	20	1.72	2.10	3.82
Finance & Insurance	350	114183	114533	0.08	2.02	1.88	1	5	6	0.19	0.96	1.15
Real Estate & Insurance Agt	72450	841869	914319	16.46	14.91	15.02	9	73	82	1.72	13.96	15.68
Business Services	28463	103018	131481	6.46	1.82	2.16	22	24	46	4.21	4.59	8.80
Educational Services	2647	483	3130	0.60	0.01	0.05	2	1	3	0.38	0.19	0.57
Health & Social Services	0	0	0	0.00	0.00	0.00	0	0	0	0.00	0.00	0.00
Accommodation, Food & Bev	12646	511127	523773	2.87	9.05	8.60	11	36	47	2.10	6.88	8.99
Other	25612	77376	102988	5.82	1.37	1.69	16	23	39	3.06	4.40	7.46
Total:	440264	5647432	6087696	100	100	100	163	360	523	28.11	64.44	92.54

*World*

YUKON & NORTH-WEST TERRITORIES:

(includes direct, indirect and incidental investment made)

Sector:	Asset Value: (000's)			% of Tot. TERR Asset Value			Frequency:			% of Tot. Frequency:		
	New:	Acqu.:	Tot:	New:	Acqu.:	Tot:	New:	Acqu.:	Tot:	New:	Acqu.:	Tot:
Agriculture	0	0	0	0.00	0.00	0.00	0	0	0	0.00	0.00	0.00
Fishing & Trapping	0	0	0	0.00	0.00	0.00	0	0	0	0.00	0.00	0.00
Logging	0	0	0	0.00	0.00	0.00	0	0	0	0.00	0.00	0.00
Mining	500	320766	321266	31.25	81.43	81.23	1	6	7	8.33	50.00	58.33
Petroleum & Natural Gas	0	0	0	0.00	0.00	0.00	0	0	0	0.00	0.00	0.00
Manufacturing	0	0	0	0.00	0.00	0.00	0	0	0	0.00	0.00	0.00
Construction	500	0	500	31.25	0.00	0.13	1	0	1	8.33	0.00	8.33
Transport. & Storage	0	4963	4963	0.00	1.26	1.25	0	1	1	0.00	8.33	8.33
Communication & Utilities	0	0	0	0.00	0.00	0.00	0	0	0	0.00	0.00	0.00
Wholesale Trade	600	0	600	37.50	0.00	0.15	1	0	1	8.33	0.00	8.33
Retail Trade	0	0	0	0.00	0.00	0.00	0	0	0	0.00	0.00	0.00
Finance & Insurance	0	0	0	0.00	0.00	0.00	0	0	0	0.00	0.00	0.00
Real Estate & Insurance Agt	0	0	0	0.00	0.00	0.00	0	0	0	0.00	0.00	0.00
Business Services	0	0	0	0.00	0.00	0.00	0	0	0	0.00	0.00	0.00
Educational Services	0	0	0	0.00	0.00	0.00	0	0	0	0.00	0.00	0.00
Health & Social Services	0	0	0	0.00	0.00	0.00	0	0	0	0.00	0.00	0.00
Accommodation, Food & Bev	0	68188	68188	0.00	17.31	17.24	0	2	2	0.00	16.67	16.67
Other	0	0	0	0.00	0.00	0.00	0	0	0	0.00	0.00	0.00
<b>Total:</b>	<b>1600</b>	<b>393917</b>	<b>395517</b>	<b>100</b>	<b>100</b>	<b>100</b>	<b>3</b>	<b>9</b>	<b>12</b>	<b>25.00</b>	<b>75.00</b>	<b>100.00</b>



*World*

YUKON & NORTH-WEST TERRITORIES:  
(direct investment only)

Sector:	Asset Value: (000's)			% of Tot. TERR Asset Value			Frequency:			% of Tot. Frequency:		
	New:	Acqu.:	Tot:	New:	Acqu.:	Tot:	New:	Acqu.:	Tot:	New:	Acqu.:	Tot:
Agriculture	0	0	0	0.00	0.00	0.00	0	0	0	0.00	0.00	0.00
Fishing & Trapping	0	0	0	0.00	0.00	0.00	0	0	0	0.00	0.00	0.00
Logging	0	0	0	0.00	0.00	0.00	0	0	0	0.00	0.00	0.00
Mining	500	320766	321266	31.25	83.93	83.71	1	6	7	10.00	60.00	70.00
Petroleum & Natural Gas	0	0	0	0.00	0.00	0.00	0	0	0	0.00	0.00	0.00
Manufacturing	0	0	0	0.00	0.00	0.00	0	0	0	0.00	0.00	0.00
Construction	500	0	500	31.25	0.00	0.13	1	0	1	10.00	0.00	10.00
Transport. & Storage	0	0	0	0.00	0.00	0.00	0	0	0	0.00	0.00	0.00
Communication & Utilities	0	0	0	0.00	0.00	0.00	0	0	0	0.00	0.00	0.00
Wholesale Trade	600	0	600	37.50	0.00	0.16	1	0	1	10.00	0.00	10.00
Retail Trade	0	0	0	0.00	0.00	0.00	0	0	0	0.00	0.00	0.00
Finance & Insurance	0	0	0	0.00	0.00	0.00	0	0	0	0.00	0.00	0.00
Real Estate & Insurance Agt	0	0	0	0.00	0.00	0.00	0	0	0	0.00	0.00	0.00
Business Services	0	0	0	0.00	0.00	0.00	0	0	0	0.00	0.00	0.00
Educational Services	0	0	0	0.00	0.00	0.00	0	0	0	0.00	0.00	0.00
Health & Social Services	0	0	0	0.00	0.00	0.00	0	0	0	0.00	0.00	0.00
Accomodation, Food & Bev	0	61435	61435	0.00	16.07	16.01	0	1	1	0.00	10.00	10.00
Other	0	0	0	0.00	0.00	0.00	0	0	0	0.00	0.00	0.00
<b>Total:</b>	<b>1600</b>	<b>382201</b>	<b>383801</b>	<b>100</b>	<b>100</b>	<b>100</b>	<b>3</b>	<b>7</b>	<b>10</b>	<b>30.00</b>	<b>70.00</b>	<b>100.00</b>

World

TORONTO:  
(including indirect and incidental investment)

Sector:	Asset Value: (000's)			% of Tot. Asset Value			Frequency:			% of Tot. Frequency:		
	New:	Acqu.:	Tot:	New:	Acqu.:	Tot:	New:	Acqu.:	Tot:	New:	Acqu.:	Tot:
Manufacturing	40752	5077138	5117890	10.11	41.72	40.71	38	127	165	5.23	17.47	22.70
Construction	770	1648214	1648984	0.19	13.54	13.12	4	3	7	0.55	0.41	0.96
Retail Trade	5540	112644	118184	1.37	0.93	0.94	12	14	26	1.65	1.93	3.58
Agriculture	0	0	0	0.00	0.00	0.00	0	0	0	0.00	0.00	0.00
Logging & Forestry	0	0	0	0.00	0.00	0.00	0	0	0	0.00	0.00	0.00
Fishing & Trapping	0	0	0	0.00	0.00	0.00	0	0	0	0.00	0.00	0.00
Mining	0	0	0	0.00	0.00	0.00	0	0	0	0.00	0.00	0.00
Petro & Natural Gas	0	0	0	0.00	0.00	0.00	0	0	0	0.00	0.00	0.00
Wholesale Trade	57185	243574	300759	14.18	2.00	2.39	122	52	174	16.78	7.15	23.93
Transport. & Storage	3221	28270	31491	0.80	0.23	0.25	8	4	12	1.10	0.55	1.65
Real Estate & Ins. Agents	60010	1783411	1843421	14.88	14.66	14.66	12	35	47	1.65	4.81	6.46
Finance & Insurance	73670	2121894	2195564	18.27	17.44	17.46	22	32	54	3.03	4.40	7.43
Acc., Food & Beverages	700	404463	405163	0.17	3.32	3.22	2	14	16	0.28	1.93	2.20
Business Service	23060	366629	389689	5.72	3.01	3.10	74	69	143	10.18	9.49	19.67
Education Service	1250	26173	27423	0.31	0.22	0.22	6	4	10	0.83	0.55	1.38
Health & Social Service	82275	2589	84864	20.41	0.02	0.68	6	5	11	0.83	0.69	1.51
Other service	54759	354039	408798	13.58	2.91	3.25	28	34	62	3.85	4.68	8.53
Total:	403192	12169038	12572230	100	100	100	334	393	727	45.94	54.06	100.00

100

World

TORONTO:  
(direct investment only)

Sector:	Asset Value:			% of Tot. Asset Value			Frequency:			% of Tot. Frequency:		
	New:	Acqu.:	Tot:	New:	Acqu.:	Tot:	New:	Acqu.:	Tot:	New:	Acqu.:	Tot:
Manufacturing	40752	2640344	2681096	10.11	32.67	31.59	38	67	105	6.35	11.20	17.56
Construction	770	1638414	1639184	0.19	20.27	19.32	4	2	6	0.67	0.33	1.00
Retail Trade	5540	110712	116252	1.37	1.37	1.37	12	13	25	2.01	2.17	4.18
Agriculture	0	0	0	0.00	0.00	0.00	0	0	0	0.00	0.00	0.00
Logging & Forestry	0	0	0	0.00	0.00	0.00	0	0	0	0.00	0.00	0.00
Fishing & Trapping	0	0	0	0.00	0.00	0.00	0	0	0	0.00	0.00	0.00
Mining	0	0	0	0.00	0.00	0.00	0	0	0	0.00	0.00	0.00
Petro & Natural Gas	0	0	0	0.00	0.00	0.00	0	0	0	0.00	0.00	0.00
Wholesale Trade	57185	45563	102748	14.18	0.56	1.21	122	29	151	20.40	4.85	25.25
Transport. & Storage	3221	28165	31386	0.80	0.35	0.37	8	3	11	1.34	0.50	1.84
Real Estate & Ins. Agents	60010	961260	1021270	14.88	11.89	12.03	12	31	43	2.01	5.18	7.19
Finance & Insurance	73670	1922419	1996089	18.27	23.78	23.52	22	22	44	3.68	3.68	7.36
Acc., Food & Beverages	700	325599	326299	0.17	4.03	3.85	2	12	14	0.33	2.01	2.34
Business Service	23060	223652	246712	5.72	2.77	2.91	74	53	127	12.37	8.86	21.24
Education Service	1250	325	1575	0.31	0.00	0.02	6	1	7	1.00	0.17	1.17
Communication	82275	794	83069	20.41	0.01	0.98	6	4	10	1.00	0.67	1.67
Other service	54759	185464	240223	13.58	2.29	2.83	28	27	55	4.68	4.52	9.20
Total:	403192	8082711	8485903	100	100	100	334	264	598	55.85	44.15	100.00

World

MONTREAL:  
(including indirect and incidental investment)

Sector:	Asset Value: (000's)			% of Tot.Asset Value			Frequency:			% of Frequency:		
	New:	Acqu.:	Tot:	New:	Acqu.:	Tot:	New:	Acqu.:	Tot:	New:	Acqu.:	Tot:
Manufacturing	166724	3831606	3998330	52.98	79.70	78.06	18	54	72	7.06	21.18	28.24
Construction	48500	7000	55500	15.41	0.15	1.08	3	2	5	1.18	0.78	1.96
Retail Trade	1495	110545	112040	0.48	2.30	2.19	8	4	12	3.14	1.57	4.71
Agriculture	0	0	0	0.00	0.00	0.00	0	0	0	0.00	0.00	0.00
Logging & Forestry	0	0	0	0.00	0.00	0.00	0	0	0	0.00	0.00	0.00
Fishing & Trapping	0	0	0	0.00	0.00	0.00	0	0	0	0.00	0.00	0.00
Mining	0	0	0	0.00	0.00	0.00	0	0	0	0.00	0.00	0.00
Petro & Natural Gas	0	0	0	0.00	0.00	0.00	0	0	0	0.00	0.00	0.00
Wholesale Trade	28078	164727	192805	8.92	3.43	3.76	41	31	72	16.08	12.16	28.24
Transport. & Storage	1290	5333	6623	0.41	0.11	0.13	4	4	8	1.57	1.57	3.14
Real Estate & Ins. Agents	3501	109624	113125	1.11	2.28	2.21	2	7	9	0.78	2.75	3.53
Finance & Insurance	49920	55300	105220	15.86	1.15	2.05	9	2	11	3.53	0.78	4.31
Acc., Food & Beverages	0	166327	166327	0.00	3.46	3.25	0	6	6	0.00	2.35	2.35
Business Service	8410	124091	132501	2.67	2.58	2.59	14	26	40	5.49	10.20	15.69
Education Service	0	0	0	0.00	0.00	0.00	0	0	0	0.00	0.00	0.00
Communication	0	624	624	0.00	0.01	0.01	0	2	2	0.00	0.78	0.78
Other service	6750	232492	239242	2.15	4.84	4.67	5	13	18	1.96	5.10	7.06
Total:	314668	4807669	5122337	100	100	100	104	151	255	40.78	59.22	100.00
								255			100	

World

MONTREAL:  
(direct investment only)

Sector:	Asset Value: (000's)			% of Tot. Asset Value			% of Tot. Frequency:					
	New:	Acqu.:	Tot:	New:	Acqu.:	Tot:	New:	Acqu.:	Tot:	New:	Acqu.:	Tot:
Manufacturing	166724	2928052	3094776	52.98	84.87	82.20	18	46	64	7.83	20.00	27.83
Construction	48500	7000	55500	15.41	0.20	1.47	3	2	5	1.30	0.87	2.17
Retail Trade	1495	110545	112040	0.48	3.20	2.98	8	4	12	3.48	1.74	5.22
Agriculture	0	0	0	0.00	0.00	0.00	0	0	0	0.00	0.00	0.00
Logging & Forestry	0	0	0	0.00	0.00	0.00	0	0	0	0.00	0.00	0.00
Fishing & Trapping	0	0	0	0.00	0.00	0.00	0	0	0	0.00	0.00	0.00
Mining	0	0	0	0.00	0.00	0.00	0	0	0	0.00	0.00	0.00
Petro & Natural Gas	0	0	0	0.00	0.00	0.00	0	0	0	0.00	0.00	0.00
Wholesale Trade	28078	73509	101587	8.92	2.13	2.70	41	26	67	17.83	11.30	29.13
Transport. & Storage	1290	5333	6623	0.41	0.15	0.18	4	4	8	1.74	1.74	3.48
Real Estate & Ins. Agents	3501	109624	113125	1.11	3.18	3.00	2	7	9	0.87	3.04	3.91
Finance & Insurance	49920	55300	105220	15.86	1.60	2.79	9	2	11	3.91	0.87	4.78
Acc., Food & Beverages	0	33229	33229	0.00	0.96	0.88	0	4	4	0.00	1.74	1.74
Business Service	8410	109880	118290	2.67	3.18	3.14	14	21	35	6.09	9.13	15.22
Education Service	0	0	0	0.00	0.00	0.00	0	0	0	0.00	0.00	0.00
Communication	0	624	624	0.00	0.02	0.02	0	2	2	0.00	0.87	0.87
Other service	6750	17149	23899	2.15	0.50	0.63	5	8	13	2.17	3.48	5.65
Total:	314668	3450245	3764913	100	100	100	104	126	230	45.22	54.78	100.00

*World*

VANCOUVER:

(includes direct, indirect, and incidental investment made)

Sector:	Asset Value: (000's)			% of Tot. Asset Value			Frequency:			% of Tot. Frequency:		
	New:	Acqu.:	Tot:	New:	Acqu.:	Tot:	New:	Acqu.:	Tot:	New:	Acqu.:	Tot:
Manufacturing	45350	1693529	1738879	16.29	50.10	47.53	13	20	33	4.89	7.52	12.41
Construction	127470	46929	174399	45.79	1.39	4.77	21	4	25	7.89	1.50	9.40
Retail Trade	6430	71253	77683	2.31	2.11	2.12	6	9	15	2.26	3.38	5.64
Agriculture	0	4745	4745	0.00	0.14	0.13	0	2	2	0.00	0.75	0.75
Logging & Forestry	0	10929	10929	0.00	0.32	0.30	0	1	1	0.00	0.38	0.38
Fishing & Trapping	10000	14667	24667	3.59	0.43	0.67	1	2	3	0.38	0.75	1.13
Mining	0	0	0	0.00	0.00	0.00	0	0	0	0.00	0.00	0.00
Petro. & Natural Gas	0	0	0	0.00	0.00	0.00	0	0	0	0.00	0.00	0.00
Wholesale Trade	3469	59459	62928	1.25	1.76	1.72	18	19	37	6.77	7.14	13.91
Transport. & Storage	570	50753	51323	0.20	1.50	1.40	3	4	7	1.13	1.50	2.63
Real Estate & Ins. Agents	32525	665361	697886	11.68	19.68	19.08	4	45	49	1.50	16.92	18.42
Finance & Insurance	350	114183	114533	0.13	3.38	3.13	1	5	6	0.38	1.88	2.26
Acc., Food & Beverages	5787	522747	528534	2.08	15.47	14.45	7	19	26	2.63	7.14	9.77
Business Service	27996	64128	92124	10.06	1.90	2.52	17	17	34	6.39	6.39	12.78
Education Service	0	0	0	0.00	0.00	0.00	0	0	0	0.00	0.00	0.00
Communication	0	2378	2378	0.00	0.07	0.06	0	1	1	0.00	0.38	0.38
Other service	18412	59079	77491	6.61	1.75	2.12	14	13	27	5.26	4.89	10.15
<b>Total:</b>	<b>278359</b>	<b>3380140</b>	<b>3658499</b>	<b>100</b>	<b>100</b>	<b>100</b>	<b>105</b>	<b>161</b>	<b>266</b>	<b>39.47</b>	<b>60.53</b>	<b>100.00</b>

World

VANCOUVER:  
(direct investment only)

Sector:	Asset Value: (000's)			% of Tot. Asset Value			% of Tot. Frequency:					
	New:	Acqu.:	Tot:	New:	Acqu.:	Tot:	New:	Acqu.:	Tot:	New:	Acqu.:	Tot:
Manufacturing	45350	1552228	1597578	16.29	52.68	49.54	13	18	31	5.08	7.03	12.11
Construction	127470	4633	132103	45.79	0.16	4.10	21	3	24	8.20	1.17	9.38
Retail Trade	6430	71253	77683	2.31	2.42	2.41	6	9	15	2.34	3.52	5.86
Agriculture	0	4745	4745	0.00	0.16	0.15	0	2	2	0.00	0.78	0.78
Logging & Forestry	0	10929	10929	0.00	0.37	0.34	0	1	1	0.00	0.39	0.39
Fishing & Trapping	10000	14667	24667	3.59	0.50	0.76	1	2	3	0.39	0.78	1.17
Mining	0	0	0	0.00	0.00	0.00	0	0	0	0.00	0.00	0.00
Petro & Natural Gas	0	0	0	0.00	0.00	0.00	0	0	0	0.00	0.00	0.00
Wholesale Trade	3469	47459	50928	1.25	1.61	1.58	18	18	36	7.03	7.03	14.06
Transport. & Storage	570	45253	45823	0.20	1.54	1.42	3	3	6	1.17	1.17	2.34
Real Estate & Ins. Agents	32525	665361	697886	11.68	22.58	21.64	4	45	49	1.56	17.58	19.14
Finance & Insurance	350	114183	114533	0.13	3.88	3.55	1	5	6	0.39	1.95	2.34
Acc., Food & Beverages	5787	297068	302855	2.08	10.08	9.39	7	16	23	2.73	6.25	8.98
Business Service	27996	61384	89380	10.06	2.08	2.77	17	16	33	6.64	6.25	12.89
Education Service	0	0	0	0.00	0.00	0.00	0	0	0	0.00	0.00	0.00
Communication	0	2378	2378	0.00	0.08	0.07	0	1	1	0.00	0.39	0.39
Other service	18412	54858	73270	6.61	1.86	2.27	14	12	26	5.47	4.69	10.16
Total:	278359	2946399	3224758	100	100	100	105	151	256	41.02	58.98	100.00

*World*

CALGARY:

(includes direct, indirect, and incidental investment)

Sector:	Asset Value: (000's)			% of Tot. Asset Value			Frequency:			% of Tot. Frequency:		
	New:	Acqu.:	Tot:	New:	Acqu.:	Tot:	New:	Acqu.:	Tot:	New:	Acqu.:	Tot:
Manufacturing	36543	524774	561317	34.71	17.67	18.26	8	18	26	5.06	11.39	16.46
Construction	7802	51542	59344	7.41	1.74	1.93	4	2	6	2.53	1.27	3.80
Retail Trade	353	1079682	1080035	0.34	36.36	35.13	2	4	6	1.27	2.53	3.80
Agriculture	0	0	0	0.00	0.00	0.00	0	0	0	0.00	0.00	0.00
Logging & Forestry	0	0	0	0.00	0.00	0.00	0	0	0	0.00	0.00	0.00
Fishing & Trapping	0	970	970	0.00	0.03	0.03	0	1	1	0.00	0.63	0.63
Mining	0	0	0	0.00	0.00	0.00	0	0	0	0.00	0.00	0.00
Petro & Natural Gas	0	0	0	0.00	0.00	0.00	0	0	0	0.00	0.00	0.00
Wholesale Trade	6166	796689	802855	5.86	26.83	26.11	14	22	36	8.86	13.92	22.78
Transport. & Storage	491	26284	26775	0.47	0.89	0.87	2	3	5	1.27	1.90	3.16
Real Estate & Ins. Agents	9197	317432	326629	8.74	10.69	10.62	6	6	12	3.80	3.80	7.59
Finance & Insurance	1450	107852	109302	1.38	3.63	3.56	6	4	10	3.80	2.53	6.33
Acc., Food & Beverages	300	2065	2365	0.28	0.07	0.08	1	3	4	0.63	1.90	2.53
Business Service	7369	52971	60340	7.00	1.78	1.96	17	22	39	10.76	13.92	24.68
Education Service	30005	0	30005	28.50	0.00	0.98	2	0	2	1.27	0.00	1.27
Communication	250	8745	8995	0.24	0.29	0.29	1	4	5	0.63	2.53	3.16
Other service	5350	277	5627	5.08	0.01	0.18	5	1	6	3.16	0.63	3.80
Total:	105276	2969283	3074559	100.00	100.00	100	68	90	158	43.04	56.96	100.00



World

CALGARY:  
(direct investment only)

Sector:	Asset Value: (000's)			% of Tot. Asset Value			Frequency:			% of Tot. Frequency:		
	New:	Acqu.:	Tot:	New:	Acqu.:	Tot:	New:	Acqu.:	Tot:	New:	Acqu.:	Tot:
Manufacturing	36543	447486	484029	34.71	25.13	25.66	8	15	23	5.59	10.49	16.08
Construction	7802	0	7802	7.41	0.00	0.41	4	0	4	2.80	0.00	2.80
Retail Trade	353	79682	80035	0.34	4.47	4.24	2	3	5	1.40	2.10	3.50
Agriculture	0	0	0	0.00	0.00	0.00	0	0	0	0.00	0.00	0.00
Logging & Forestry	0	0	0	0.00	0.00	0.00	0	0	0	0.00	0.00	0.00
Fishing & Trapping	0	970	970	0.00	0.05	0.05	0	1	1	0.00	0.70	0.70
Mining	0	0	0	0.00	0.00	0.00	0	0	0	0.00	0.00	0.00
Petro & Natural Gas	0	0	0	0.00	0.00	0.00	0	0	0	0.00	0.00	0.00
Wholesale Trade	6166	753208	759374	5.86	42.29	40.26	14	19	33	9.79	13.29	23.08
Transport. & Storage	491	26284	26775	0.47	1.48	1.42	2	3	5	1.40	2.10	3.50
Real Estate & Ins. Agents	9197	317432	326629	8.74	17.82	17.32	6	6	12	4.20	4.20	8.39
Finance & Insurance	1450	107852	109302	1.38	6.06	5.79	6	4	10	4.20	2.80	6.99
Acc., Food & Beverages	300	2065	2365	0.28	0.12	0.13	1	3	4	0.70	2.10	2.80
Business Service	7369	36992	44361	7.00	2.08	2.35	17	16	33	11.89	11.19	23.08
Education Service	30005	0	30005	28.50	0.00	1.59	2	0	2	1.40	0.00	1.40
Communication	250	8745	8995	0.24	0.49	0.48	1	4	5	0.70	2.80	3.50
Other service	5350	277	5627	5.08	0.02	0.30	5	1	6	3.50	0.70	4.20
Total:	105276	1780993	1886269	100	100	100	68	75	143	47.55	52.45	100.00

143

100.00