

124913

128

UNCLASSIFIED
DATE 11/11/01
BY 111111

RESEARCH AND DEVELOPMENT BRANCH
DEPARTMENT OF NATIONAL DEFENCE
CANADA

DEFENCE RESEARCH ESTABLISHMENT OTTAWA

DREO TECHNICAL NOTE NO. 79-14
DREO TN 79-14

MECHANICAL ENGINEERING DESIGN OF THE DREO OPTICAL RECORDER FOR SEASAT

by

D. Hidson and V. Pede



PROJECT NO.
33D00

SEPTEMBER 1979
OTTAWA

2
3
4
5
6
7
8
9
10
11
12

CAUTION

This information is furnished with the express understanding that proprietary and patent rights will be protected.

RESEARCH AND DEVELOPMENT BRANCH

DEPARTMENT OF NATIONAL DEFENCE
CANADA

DEFENCE RESEARCH ESTABLISHMENT OTTAWA

TECHNICAL NOTE NO. 79-14

MECHANICAL ENGINEERING DESIGN OF THE DREO
OPTICAL RECORDER FOR SEASAT

by

D. Hidson and V. Pede

Protective Sciences Division

PROJECT NO.
33D00

SEPTEMBER 1979
OTTAWA

TABLE OF CONTENTS		PAGE
1.	INTRODUCTION	1
2.	GENERAL DESCRIPTION	2
3.	COMPONENT DESIGN	6
	3.1 FRAME	6
	3.2 INTERFACE PLATE	6
	3.3 SUPPORT STRUCTURE	7
	3.4 FILM DRIVE UNIT	8
	3.4.1 MOTOR BASE PLATE	8
	3.4.2 MOTORS	11
	3.4.3 FILM CASSETTES	11
	3.5 OPTICS	13
	3.5.1 LENS	13
	3.5.2 LENS POSITIONER	13
	3.5.3 ANNOTATION	16
	3.6 ENCLOSURE	16
	3.7 OPTICAL TABLE	17
4.	INSTALLATION AND OPERATION	17
	4.1 ALIGNMENT	19
	4.1.1 CAPSTAN - CRT ALIGNMENT	19
	4.1.2 FOCUSING	19
	4.2 FILM LOADING	21
5.	SUMMARY	22
6.	ACKNOWLEDGEMENTS	23
	REFERENCES	24
	APPENDIX	25

UNCLASSIFIED

ABSTRACT

50 // This paper contains a description of the mechanical engineering aspects of the DREO optical recorder for SEASAT. The concept, design and construction are discussed in detail.

The device receives a signal from the satellite and converts it into an intensity modulated line on an oscilloscope. This line is focused by a lens system on to a moving film. The motion of the film allows an image to build up. The speed and tension of the film are controlled by servomotors.

The recorder functioned well and produced valuable information before the failure of SEASAT. //

RÉSUMÉ

Ce document contient une description des caractéristiques techniques du lecteur optique utilisé par le CRDO dans le SEASAT. On y trouve également une description détaillée de la conception et fabrication de l'appareil.

Le lecteur reçoit un signal émis par le satellite et le transforme en ligne d'intensité modulée sur un oscilloscope. Cette ligne est ensuite transmise par un système d'optique sur une pellicule en mouvement, qui permet de créer une image. La vitesse et la tension de la pellicule sont contrôlées par des servomoteurs.

Le lecteur s'est avéré une bonne source de renseignements jusqu'à ce que le SEASAT tombe en panne.

PRECEDING PAGE BLANK

UNCLASSIFIED

1. INTRODUCTION

The SEASAT satellite is a surveillance satellite designed for the monitoring of large areas of ocean at low cost. Its scanning system utilizes synthetic-aperture radar and transmits radar pulses in the L-Band down to the Earth's surface. Pulses of this frequency can easily penetrate clouds and other adverse atmospheric conditions enabling the satellite to pick up clear reflections and produce high-resolution pictures of the ocean surface.

The operation of the Optical Recorder may be seen in Fig. 1. The satellite transmits a radar pulse to the earth and picks up the reflection. This data is then transmitted to the ground stations, of which one is located at Shoe Cove, Newfoundland. There, the signal is processed and presented as a single intensity modulated straight-line trace on an oscilloscope. A lens system then focusses an image of this line on a photographic film. The film is moved through the image plane at a constant velocity allowing the continuous exposure of line images to build up a raster. After the film is developed, it is passed through a correlator where the astigmatism is removed and two Fourier transforms are performed optically. An image of the Earth's surface is the result.

The design and construction of the optical recorder and correlator was assigned to a contractor. Slow delivery of parts to the contractor delayed the expected completion date of the recorder and correlator until well after the launch date of the satellite. Because of the high cost of launching a satellite and the risk that the satellite may fail shortly after launch, it is extremely important to be able to record data as soon as transmissions begin.

A digital tape recorder was to be used as a back-up to the contractor's optical recorder. In the event of a failure in the optical recorder, all data would not be lost. However, the tape recorder had a limited bandwidth which restricted the amount of detail that could be recorded. Also, there would be no method of evaluating the tape recorded data until the completion of the contractor's optical recorder. There would thus be no way of verifying if the system were operating correctly. Since a prototype correlator already existed at DREO, a decision was made to proceed with the design and construction of a back-up optical recorder at DREO.

Several design compromises were made in order to reduce design and manufacturing time sufficiently to meet the required completion date. Long delivery times for Infodex oscilloscopes

UNCLASSIFIED

eliminated them from consideration in the back-up recorder. In their place, the oscilloscope from the APS-94 airborne radar recording system was chosen. The performance of the APS-94 oscilloscope was inferior to that of the Infodex system but judged sufficient for use in the back-up recorder. Optimum performance required the design of a special lens but the time involved in such an undertaking made this impossible. A commercial lens system had to be found that would provide satisfactory performance. Selection and testing of candidate lenses proceeded concurrently with the design and manufacture of the recorder. The specifications for the contractor's recorder called for two films, two lenses and two oscilloscopes. To reduce manufacturing time only one film, oscilloscope and lens were used in the back-up recorder. As a result of this, only one-half of the swath swept by the satellite could be recorded. With these compromises in mind, the design of the recorder was begun.

2. GENERAL DESCRIPTION

The satellite transmits to the ground station where the signal is RF down-converted. This signal is processed and presented as a single intensity-modulated straight line on an oscilloscope.

The recorder consists of eight main elements (see Fig. 2):

- (1) the APS-94 oscilloscope and its support brackets;
- (2) the lens assembly and carrier;
- (3) the film drive assembly;
- (4) the frame;
- (5) the annotation assemblies;
- (6) the optics table with vibration isolation;
- (7) the light-tight cover (not shown);
- (8) the servomotor control unit (not shown).

The APS-94 oscilloscope contains two CRT display screens, but only one is utilized by this recorder. The oscilloscope is mounted rigidly to the table by means of a heavy 12.7-mm-thick aluminum support bracket.

The lens assembly is made up of two Schneider photographic lenses mounted front-to-front by means of a coupler

UNCLASSIFIED

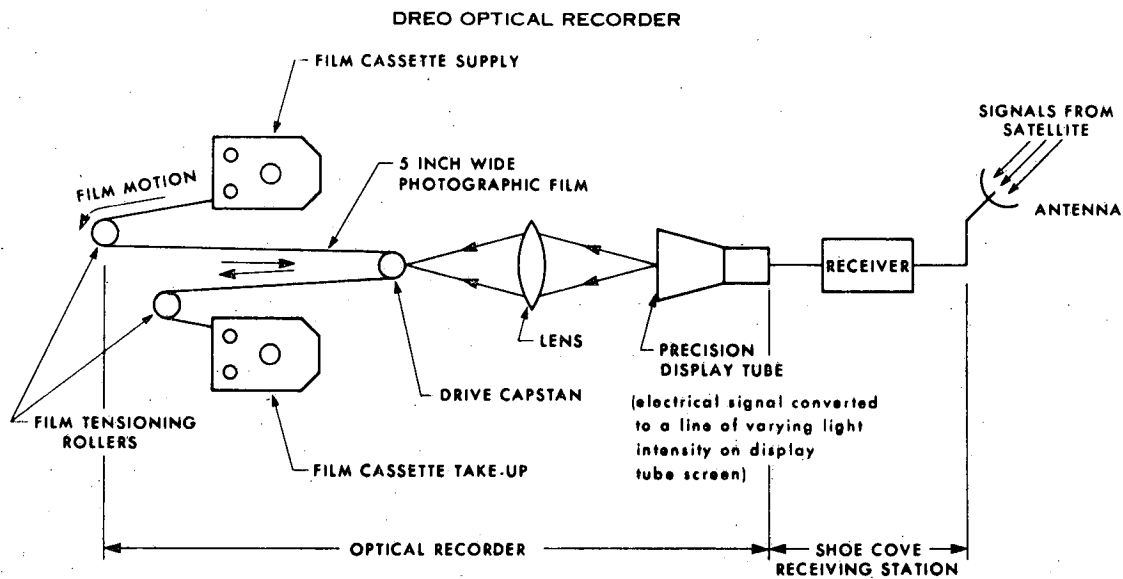

FIGURE 1

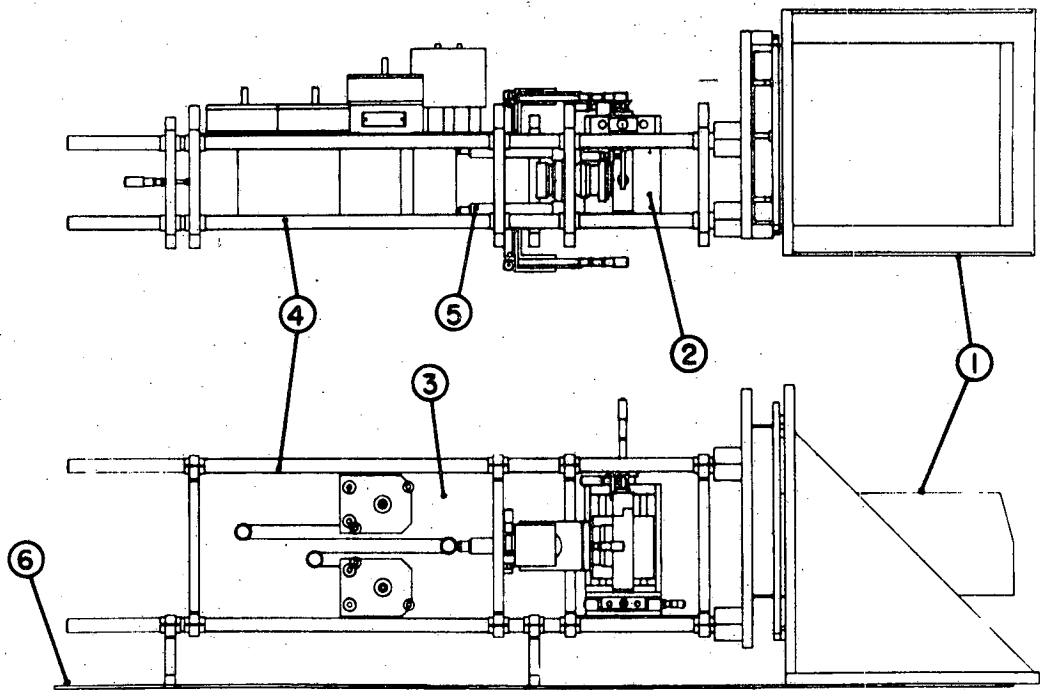

FIGURE 2

ring. This assembly is then mounted on a Newport Research Corporation lens carrier with five degrees of freedom. This carrier is attached to the recorder frame by means of two rod plates.

The film drive assembly consists of a motor base plate, five dc servo motors, two film cassettes, and two encoder assemblies. The motors are mounted on the back of the plate and the drive shafts project through holes in the plate to drive and tension the film.

The annotation assemblies provide a time pulse and index line on each side of the image. A light-emitting diode (LED) is used as a light source in the form of a segmented figure ".8" (decimal eight). A continuously illuminated dot provides the index line while one flashing segment provides timing marks. The image of this source is focussed on to the film with a microscope objective producing a magnification of about 0.2 at the image plane. Two micrometers allow two degrees of freedom for alignment and focus for each assembly.

The recorder frame ties the oscilloscope, lens, film drive, and annotation assemblies together and provides the basis for their alignment. The frame is made up of an interface plate, four Super Invar tie bars, four rod plates and two tie-bar supports. The interface plate couples the Super Invar tie bars to the front of the APS-94 oscilloscope and precisely aligns the bars perpendicular to the oscilloscope face. The circular CRT screen is centered within the four bars. The film drive assembly and lens carrier are each attached to two rod plates. These plates slide on the tie rods (along the axis perpendicular to the oscilloscope face) and thus allow the distance between the phosphor on the CRT screen and the film plane to be controlled. The weight of the film drive assembly is transmitted to the optics table by means of the two tie-bar supports. This prevents any sagging of the tie bars and loss of alignment. The frame and oscilloscope support are rigidly fixed to the optics table. An optics table was chosen for the base as only it could guarantee a stable and flat surface free from the dangers of warpage. The table is supported on four pneumatic legs to isolate it from vibration.

A light-tight cover encloses the whole recorder including the oscilloscope. This cover protects the film from ambient light while the recorder is running and the lens assembly from dust. The enclosed space is ventilated with filtered air so that heat generated by the motors and oscilloscope may be dissipated with a minimum temperature rise.

A servo control unit is mounted on a rack separate from the recorder and is connected to it by cables. The control unit is described in Ref. 1.

3. COMPONENT DESIGN

3.1 FRAME

The frame was designed to accommodate changes in lens focal length. When design of the frame was begun, the lens had not been chosen. Thus a suitable structure had to incorporate the ability to vary the distance between the film plane and the CRT screen in order to allow for lenses of differing focal lengths. When fixed, this distance must be very stable because candidate lenses could have a very small depth of field.

Several parts of the frame were commercial items manufactured by Burleigh Instruments. Their six-inch (152.4 mm) optical erector set provided a basis for the frame.

The film drive unit and the lens positioner are both bolted to two rod plates each. These plates are constructed from 3/4-in. (19.1 mm) aluminum and use brass split-tube clamps to enable the plates to slide along the tie bars and be clamped in position as required. Three SG-640 plates with a 6-inch-diameter (152.4 mm) clearance hole and one SG-630 blank plate were used.

The tie bars are chrome-plated Super Invar, centerless ground to precision tolerances. Four 25.39-mm-diameter bars 1295 mm long were used. Super Invar was chosen as it was felt that a suitable lens could have an extremely small depth of field, possibly approaching 0.005 mm. If carbon steel were used and an expansion of only 0.002 mm allowed, the maximum permissible temperature variation would only be ± 0.8 K. If Super Invar is used, then a temperature variation of ± 7 K can be allowed as Super Invar has an extremely small coefficient of expansion of

$3.6 \times 10^{-7} \text{ K}^{-1}$. This specification was later relaxed to 0.025 mm but not until the design of the frame was finalized.

3.2 INTERFACE PLATE

The interface plate was designed to connect the main frame to the APS-94 oscilloscope. It was important the interface be accurate, rigid and stable as any movement would necessitate re-alignment of the camera system. The interface plate has five dowel pins pressed into it (see Fig. 7). These pins maintain the alignment while the frame and oscilloscope are bolted together and allow the two units to be re-assembled without extensive adjustments to regain alignment. Two pins, with pointed tips, (1) fit into two bushings on the oscilloscope with a maximum clearance of 0.0005 in. (0.013 mm). These locate the frame in the vertical and horizontal directions. The other three pins (2) have spherical ends and are arranged in a triangular pattern.

These pins butt up against corresponding pins on the oscilloscope and locate the frame in the axial direction. The interface plate and oscilloscope are held together by five socket-head cap screws. The plane defined by the position of the plate is important as it defines the position of the other equipment on the frame throughout the operation of the recorder.

The Super Invar bars (3) of the frame are attached to the interface plate by four steel blocks (4). These blocks were first rough-bored then bolted and doweled to the plate. After this, the bores in the blocks were machined to provide a 0.013-mm interference fit for the Super Invar bars. The bores were machined perpendicular to the plane formed by the tips of the round dowel pins to within 0.013 mm. The ends of the Super Invar bars were drilled and tapped and were pulled and locked into the blocks by means of socket-head cap screws (5).

The interface plate was made out of 7075-T6 aluminum alloy plate which has a tensile strength equal to mild steel and therefore provides a distortion-free coupling between the frame and oscilloscope. Holes through the plate allowed access to the oscilloscope controls. Four holes (7) provide access to the alignment screws on the oscilloscope control panel. A threaded steel rod (8) was used to activate the display blanking switch on the oscilloscope.

3.3 SUPPORT STRUCTURE

The film drive unit and oscilloscope weigh approximately 100 kg and so special supports were incorporated into the frame design to counteract distortion.

The APS-94 oscilloscope had two locating pins on the front of its frame which are used to locate it in the welded aluminum support bracket. Two bushings, which were machined to accept these pins, were pressed into the front face of the support bracket. On final assembly, the oscilloscope and its support were installed as one unit. A jack temporarily supported the back of the oscilloscope keeping the front face perpendicular to the surface of the optical table. The distance between the back of the front face of the oscilloscope and the support bracket was measured and two spacers machined to this measurement were installed. The oscilloscope is fastened to the support by three bolts and the support to the optical table by four bolts.

Extra supports were placed between the table surface and the film drive unit at each end of the unit (see Fig. 9). They were constructed from pieces from Burleigh Instruments SG-621 converter set and items manufactured at DREO. Spacers were used between the support pedestals and the clamps to take up tolerances. The entire recorder assembly (film unit, lens and oscilloscope) was bolted to a Newport Research Corporation optics table.

3.4 FILM DRIVE UNIT

The film drive unit consists of a motor base plate, five dc servo motors, two film cassettes and two encoder assemblies. The film path is shown in Fig. 1. The film passes from the supply cassette around the first tension roller, the capstan, the second tension roller, and then into the take-up cassette. One motor drives the capstan, two tension motors drive the two tension rollers and two reel motors supply torque to the film spools. The reel motors supply 12.01 newtons tension to the film between the tension roller and the feed cassette and 3.11 newtons between the tension roller and the take-up cassette, while the tension rollers supply tension of 16.23 newtons between the tension rollers and capstan. The tension has to be sufficient to ensure that the film is in contact with the capstan over its entire width with the capstan motor turned off: the torque produced by the first tension motor is reduced until the film begins to be moved by the second tension motor, after which the capstan supplies torque to bring the film up to speed. The film speed at the capstan is monitored and the motor regulated by a servomechanism to maintain constant speed. The torque produced by the motors is proportional to current. The current to the reel motors is slowly regulated to compensate for a varying spool diameter as film is withdrawn or supplied to the cassettes.

3.4.1 MOTOR BASE PLATE

The motors are mounted on 13-mm-thick aluminum tool and jig plate. This plate was cast and then machined flat both sides to produce a stress-free plate less likely to warp than a conventional rolled plate. The tension and capstan motors are bolted directly to the motor plate and the shafts project through 32-mm holes in the plate. The holes were kept as small as possible to prevent possible plate warpage.

The reel motors are mounted on 140-mm-diameter spacer rings 54 mm long to allow room for the drive coupling to the cassette (see Fig. 4). This coupling engages a pin on the central spindle of the cassette. The spacer ring also encloses the encoder disk and sensor. The encoder senses the speed of the reel motor from which is calculated the diameter of the film on the spool. From this, the torque of the reel motor is adjusted to compensate for the changing diameter.

The motor base plate is bolted between two rod plates, one on each end. The bars of the frame pass through the bushings in the rod plates allowing the whole film drive unit to be moved along the frame for adjustment of the CRT screen-to-film-plane distance.

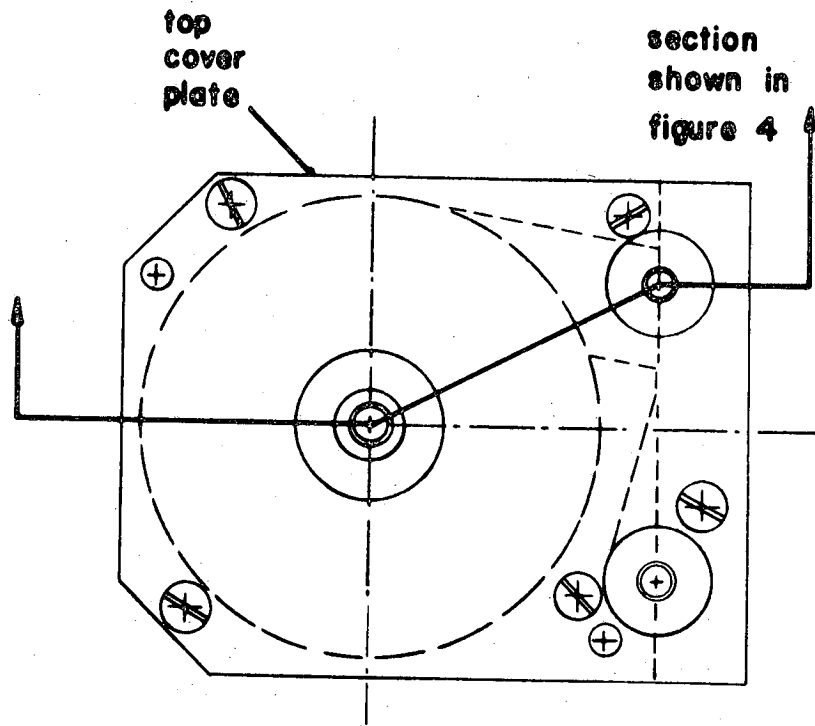

FIGURE 3

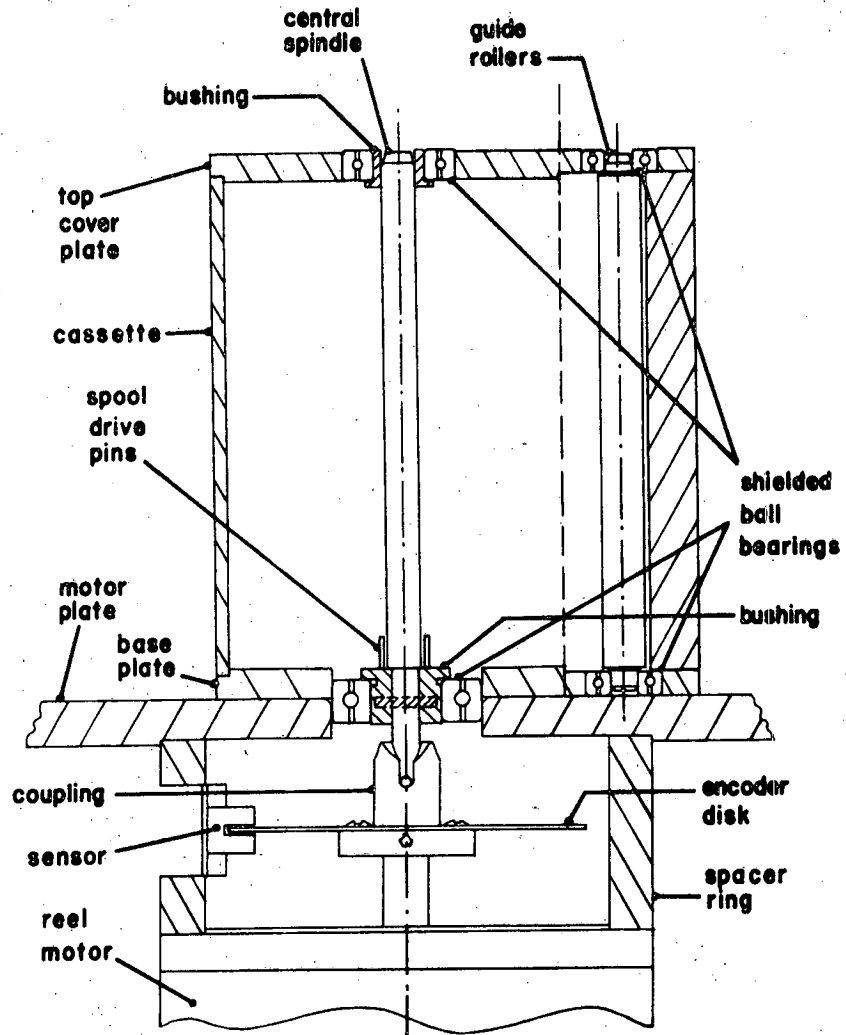

FIGURE 4

3.4.2 MOTORS

The motors chosen for the tension and reel motors were PMI U12M4 dc servo motors. (See colour photographs following diagrams). The two reel motors were standard off-the-shelf items but the two tension motors had non-standard shafts. The shafts were 25.4-mm-diameter stainless steel and were 165 mm long. Tests showed that there was insufficient friction between the steel shaft and the film to provide the required tension. Various materials were examined and a surface of natural rubber latex was found to provide adequate friction. The motor shaft was primed with Bostik 3073 adhesive. Textile Rubber Chemical Company Latex compound number 01344 was applied to the shaft by a dipping process. The natural rubber latex used was prevulcanized and did not require that the motor be exposed to the high temperatures required for vulcanizing. The result was a coating 0.38 mm thick with 0.02 mm maximum out-of-round and a 0.08-mm taper.

The capstan motor was specially built but was based on the PMI U12M4 motor. Shaft run-out was critical as the film is exposed at the capstan shaft. This motor had a precisely ground 25.40-mm-diameter shaft, 165 mm long, set in ABEC class 7 bearings. A run-out of less than 0.003 mm was achieved at the tip of the shaft. The motor was also equipped with two encoders for speed and direction information and a flywheel for speed stability.

3.4.3 FILM CASSETTES

The film was stored and taken up in two separate cassettes. Three sets of cassettes were manufactured (a set being a supply and a take-up cassette). The cassettes (shown in Fig. 3 and 4 and colour photographs following diagrams) are light-tight so that the recorder may be loaded under normal light levels and each one can hold 46 m of 5-mil (0.13-mm) film on an American National Standard No. 8 spool.

Each cassette was machined out of a block of aluminum and each end was closed by means of an aluminum plate which was screwed on the main block. The base plate contained three bearings; two for the guide rollers and one for the central spindle of the cassette.

The central spindle was pressed into a bushing and this in turn was pressed into the bearing in the base. The top plate of the cassette housed similar bearings which allowed a sliding-fit for the spindle and rollers. The spool was driven by two pins pressed into the bushing on the central spindle engaging in slots in the end of the spool. Foam washers between the lower bushing and the lower end of the spool kept the spool pressed against the bearing in the top cover and compensated for production tolerances in the length of the spool. The cassette

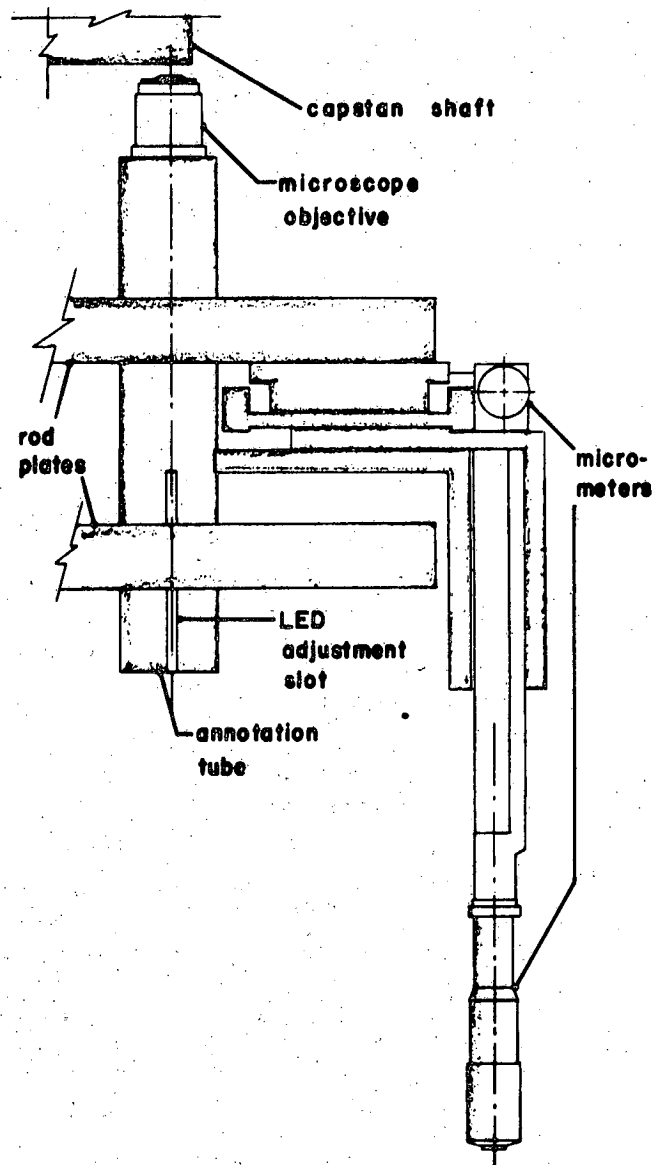

FIGURE 5

is light-tight as the film follows an "S"-path around two 13-mm-diameter rollers into the spool cavity.

The spindle and rollers are mounted in shielded ball bearings. These were used because they offered low resistance and smooth operation while preventing dirt and dust from entering the bearing. Sealed bearings were not used as they have much higher rotational resistance than shielded ones.

All bearings were pressed into the cover plates and the rollers and spindle were pressed into the bearings in the cassette's base plate so that they remain with the cassette body when the top cover plate is removed. The rollers and spindle were machined to have a sliding fit in the bearings in the top cover plate.

The cover and base plates reach down into the main cavity of the cassette to prevent possible light leakage in the event that the cover or the cassette body is not flat. The base plate is fixed to the body by flat-head machine screws and the top plate by means of knurled thumb screws.

The spindle bearing in the base plate protrudes below the cassette and is used to index the cassette on the motor plate. It fits into a hole machined in that plate. The spindle has a 3-mm-diameter dowel pin pressed into it at right angles which serves to engage a coupling mounted on the end of the shaft of the reel motor. The cassette is held on the base plate by two threaded rods which pass through holes in the side of the cassette. Two knurled nuts on the ends of the rods hold the cassette on the base plate.

3.5 OPTICS

3.5.1 LENS

No commercially available lens or lens system was really suitable for the requirements of the optical recorder. Time did not allow for the design and manufacture of a special lens so a compromise design was arrived at from a combination of commercially available lenses. Two "Symmar" portrait lenses made by Schneider Optik were mounted front-to-front by means of a connecting collar. Optical tests showed that the performance requirements were most nearly met by this configuration. Each lens had a focal distance of 180 mm and an angle of view of 70°.

3.5.2 LENS POSITIONER

The lens positioner accepted the lens assembly and controlled its attitude in space. (See Fig. 8). It was made up from items manufactured by the Newport Research Corporation.

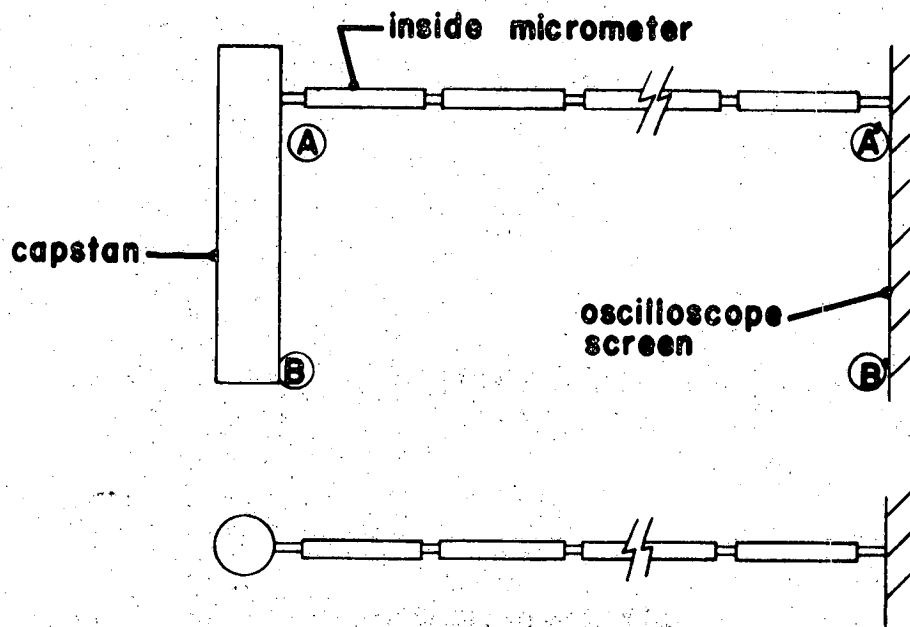

FIGURE 6

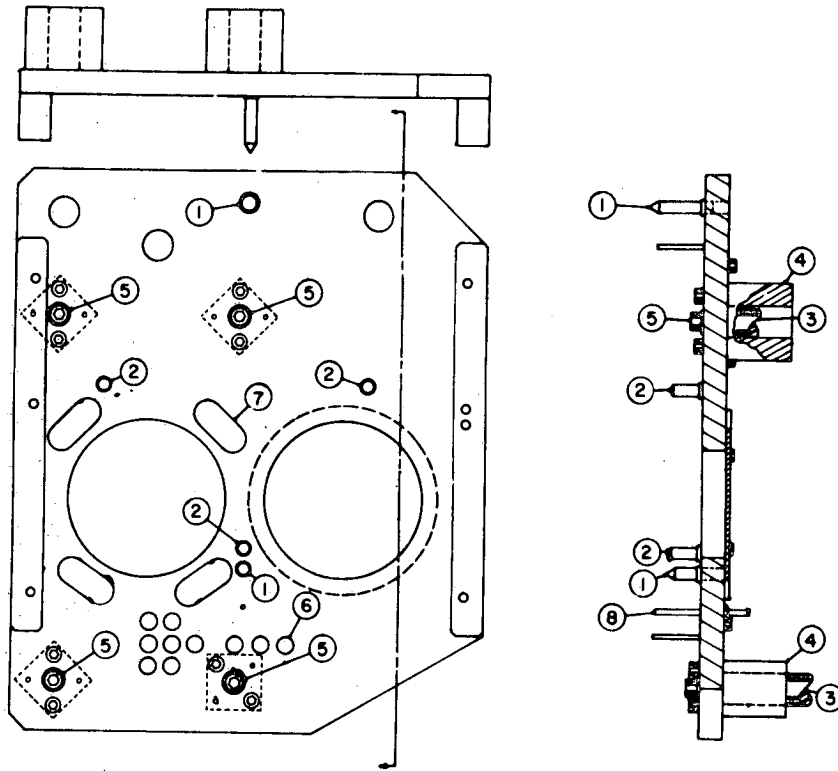

FIGURE 7

Five degrees of freedom were available to the lens: axial, horizontal, vertical, pitch and yaw. Each adjustment of the lens's position can be controlled by micrometers. The lens's positioner consisted of a Model 700 three-axis positioner and Model 400 two-axis translation stage. The lens assembly itself is mounted on a block of aluminum, 25 mm thick, which is fixed to the Model 700 lens positioner by a dowel pin and held in place by two cap screws.

The positioner and translation stage were mounted on an aluminum sub-plate which, in turn, was bolted between two Burleigh Instruments SG-640 rod plates for mounting on the Super Invar frame. Focussing of the CRT image on the film is accomplished by sliding the entire assembly on the frame for coarse adjustments and using the axial micrometer on the translation stage for fine adjustments.

3.5.3 ANNOTATION

The purpose of the annotation subsystem was to produce an index line and a timing marker on each side of the image. (See Fig. 5). An aluminum tube contains at one end a Hewlett-Packard No 5082-7670 light-emitting diode and at the other a microscope objective. The LED display is of the form ".8". The decimal point emits light constantly producing the index line on the film, while a line segment flashes to produce the timing marks. The magnification of the LED image is approximately 0.1 at the film plane. The annotation assemblies were adjusted so that both timing marks fell on the centre line of the capstan. Adjustments were accomplished by means of two Ardel-Kinematic translation stages allowing movement in two dimensions. Both of these were controlled by micrometers. The image magnification may be changed by moving the LED along the aluminum tube by means of a locking screw projecting through the side of the tube. This prevents rotation of the LED and enables it to be locked in position. Both the annotation assemblies were bolted to the front rod plate of the film drive unit.

3.6 ENCLOSURE

Three factors in the machine environment had to be controlled carefully; light, heat and vibration. Vibration was controlled by means of a pneumatic optical table and heat and light by a cover box.

The cover box was made from 6-mm plywood and fitted over the whole apparatus - frame, film drive and oscilloscope. Two doors were built into the side of the structure: one to allow access to the film cassettes and another to allow access to the main lens. The interior of the box was painted flat black and the joints around the doors and table top were sealed with weather stripping. During the operation of the recorder, the

oscilloscope and motors produce heat and because of the optical requirements of the apparatus a cooling mechanism had to be provided. To accomplish this, a fan was mounted in the top of the box in an assembly with an air filter. The fan drew in air and allowed it to circulate over the motors, camera assembly and oscilloscope after which it exited through a light trap above the oscilloscope. Both the entrance and exit traps were light-tight. A 115-volt ac motor drove the fan at 1750 rpm. A small calculation and test demonstrated that this was quite enough to control the interior of the box during operation to within 1 K.

3.7 OPTICAL TABLE

An optical table manufactured by the Newport Research Corporation was used as a base for the whole recorder. A model RS-46-8 table top, eight inches thick, was used. The table top is a honeycomb panel consisting of two face sheets or "skins" bonded to opposite sides of a honeycomb core. This type of design is highly efficient and offers a very high rigidity-to-weight ratio. The working surface of the table is 4.7-mm-thick ferromagnetic stainless steel worked to a low-reflective finish, drilled and tapped with 1/4-20 mounting holes on 25.4-mm centers. The bottom skin of the table is carbon steel. The flatness tolerance of the table top was ± 0.13 mm.

The table surface was supported on four pneumatic legs. The pneumatic isolation mount is essentially a pressurized cylinder with an internal piston. The air pressure against the piston supplies the upward force required to support the load and the elasticity of the gas provides the low spring constant required for vibration isolation. The pneumatic legs also contain a horizontal isolation piston that provides a low spring constant in the horizontal direction for both large- and small-amplitude motions.

4. INSTALLATION AND OPERATION

The optical recorder was installed in the Satellite Receiving Station, Shoe Cove, Newfoundland in August 1978. Several test runs were performed using various types of film and a trace on the oscilloscope containing 4.25 dots per millimeter. In the image, on all types of film, some variation in intensity was noted across the width of the film. The variation appeared approximately Gaussian about the centre of the image and was attributed to the properties of the lens.

The image that appeared on the film was not the final product, that is, not a normal two-dimensional image. The image was illuminated with coherent light from a He-Ne laser. This beam passed through the film and was processed in an optical correlator which produced the final image ready for viewing.

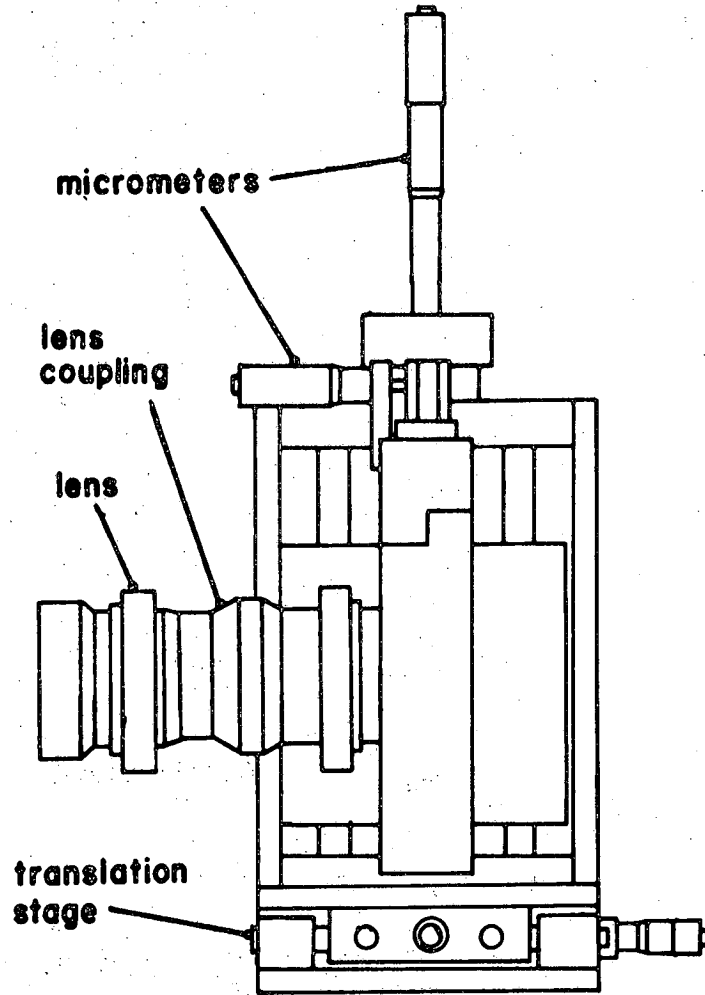

FIGURE 8

4.1 ALIGNMENT

4.1.1 CAPSTAN - CRT ALIGNMENT

Due to the small depth of field of the lens, the capstan and CRT face have to be aligned accurately (See Fig. 6). This procedure is carried out with the entire lens and annotation assemblies removed. The distance of the capstan from the oscilloscope screen is known from the properties of the lens and the film drive unit is moved on the tie bars to find this distance approximately. The distances AA' and BB' have to be within 0.003 mm of each other. This measurement is accomplished by means of an inside micrometer. This device is built up from various segments of known length screwed together and tipped by a micrometer.

A straight-line image of 4.25 dots per mm is produced on the screen. One end of this corresponds to point A' and the other to point B'. The image is produced for vertical positioning of the micrometer on the oscilloscope screen. AA' and BB' are both measured during which AB and A'B' are maintained equal to the length of the image. The adjustment of the distance AA' and BB' is made by moving the alignment controls of the oscilloscope screen which enable the screen to be tilted. A locking nut is loosened, the screw is adjusted and then the locking nut is locked. This process constitutes an adjustment of one of the four alignment controls on the oscilloscope. One of these may be fixed while the other three are varied and by an interactive process the distances AA' and BB' may be equalized readily. After this adjustment the capstan and oscilloscope screen are parallel.

4.1.2 FOCUSING

The distance of the capstan from the screen has been set approximately. The lens assembly is mounted in place. A paper sleeve with a fluorescent surface is slipped over the capstan. This surface renders the image more easily visible. The thickness of the screen is compensated for by moving the film drive unit on the tie rods: this amounts to the nominal screen thickness, or 0.500-in. (12.7 mm). The paper sleeve has an ink line drawn on it denoting the center line of the capstan and two marks on each end of this line signifying the length and position of the image on the capstan. This length corresponds to a magnification of 0.735. Observations of the line image are made by means of a travelling microscope set up between the capstan and the front rod plate at the end of the film drive unit.

Lens yaw and transverse adjustments are made to bring the image within the demarcation points and final roll adjustment to bring the image onto the line on the capstan is made electronically in the oscilloscope. The required image length is obtained by moving the film drive unit on the tie bars. The

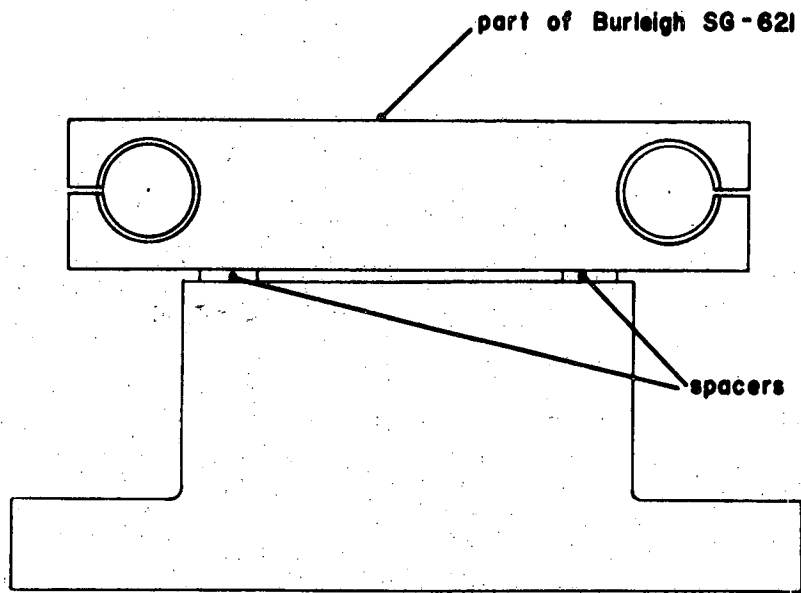

FIGURE 9

final adjustments for focus were made by micrometers on the translation stage of the lens assembly.

The annotation assemblies are then installed and the LED's switched on. The magnification of the LED is adjusted by sliding the LED carrier along the annotation tube (See Fig. 5) The image was aligned and focussed by means of the micrometers on the annotation assemblies.

All focussing complete, the paper tube was removed from the capstan and the difference between the paper and the film thickness compensated for by moving the film drive unit on the tie bars. All micrometers and rod plates are locked in position.

The cover box is now installed and the recorder is ready for operation. The main hatch in the cover box allows access only to the film cassettes: this is to prevent accidental adjustment of the lens.

4.2 FILM LOADING

Film may be loaded into the cassettes under dark room conditions only. The top cover plate is removed from the cassette and the spool inserted over the central spindle. At the same time the film has to be threaded through the guide rollers so that a few inches are protruding from the exit slot. The cover plate is then screwed back into place. The cassette is now mounted on the film drive unit and the film is pulled out and threaded around the tension rollers and capstan. The film is then fed into a take-up spool which is inserted into the body of the take-up cassette. The film is threaded round the guide rollers, the cover plate installed and the cassette fixed to the film drive unit. The spool in the loaded cassette is turned back to take up slack. The recorder is now ready for operation. Loading of the cassettes into the camera may be done under ambient room light conditions.

5. SUMMARY

The recorder was installed at the satellite receiving station at Shoe Cove, Newfoundland at the beginning of August 1978. The recorder was operated successfully gathering much useful information before the untimely demise of the SEASAT Satellite (Ref. 2). The signal was lost on day 106 of the mission due to a catastrophic failure in the satellite electrical power subsystem. Efforts to remedy the problem were to no avail and SEASAT was declared officially lost on November 21, 1978.

6. ACKNOWLEDGEMENTS

We would like to thank the DREO Machine Shop under the able direction of Mr. Bill Dickson for their excellent technical work and co-operative attitude. Without them the optical recorder would not have seen the light.

REFERENCES

- (1) Defence Electronics Division Report (to be issued).
- (2) SEASAT Log No. 2, Jet Propulsion Laboratory, January 25, 1979.

APPENDIX

A.1 ORIGINAL SPECIFICATIONS

These specifications were the original boundary conditions that determined the basic design of the DREO optical recorder.

CRT - APS-94D

Spot size	0.00065 in.
Nominal screen size	5 in.

RANGE RECORDING

Full aperture width at CRT	4.25 in.
----------------------------	----------

Magnification from CRT to film	1.36:1
--------------------------------	--------

Full aperture at film	3.12 in.
-----------------------	----------

Highest spatial frequency	
- at CRT	31.5 lines mm^{-1}
- at film	42.9 lines mm^{-1}

Beam velocity	
- at CRT	$6.66 \times 10^5 \text{ mm s}^{-1}$
- at film	$4.90 \times 10^5 \text{ mm s}^{-1}$

Maximum spot position error over entire CRT for low distortion	0.04% desired
--	---------------

AZIMUTH RECORDING

Nominal film velocity	40.0 mm s^{-1}
-----------------------	--------------------------

UNCLASSIFIED

Film velocity range 35-45 mm s⁻¹
Film velocity stability $\pm 0.06\%$
Velocity controls Hand settable and remote settable from satellite velocity information.

FILM

Type Kodak RAR 5498
Film base Triacetate
Thickness 5.25 mil.
Film width 5 in. $-1/32 + 1/64$
Length of film on one channel for one ten minute pass 24 m excluding leader

RECORDING LENS

f/number f/2.8 or better
MTF at image preferably $>50\%$ at 43 lp mm⁻¹ across entire 79-mm aperture

ANNOTATION

Azimuth LEDs to record GMT on film from data received during satellite pass.

UNCLASSIFIED

MECHANICAL

CRT - lens - capstan spacing	Dependent on lens selected.
CRT - lens - capstan spacing setability	± 0.0005 in.
CRT - lens - capstan spacing stability	± 0.0005 in.
Lens centering relative to axis	± 0.01 in. range; ± 0.005 in. azimuth.
Tilt of lens axis relative to optic axis	to be determined.
Maximum deviation of capstan from desired position	± 0.0005 in.

LIGHT-EMITTING DIODES

Type	HP 5082-7670 LED with green emission
Object size	0.5 x 0.1 cm (bar) 0.19 cm DIA.(dot)

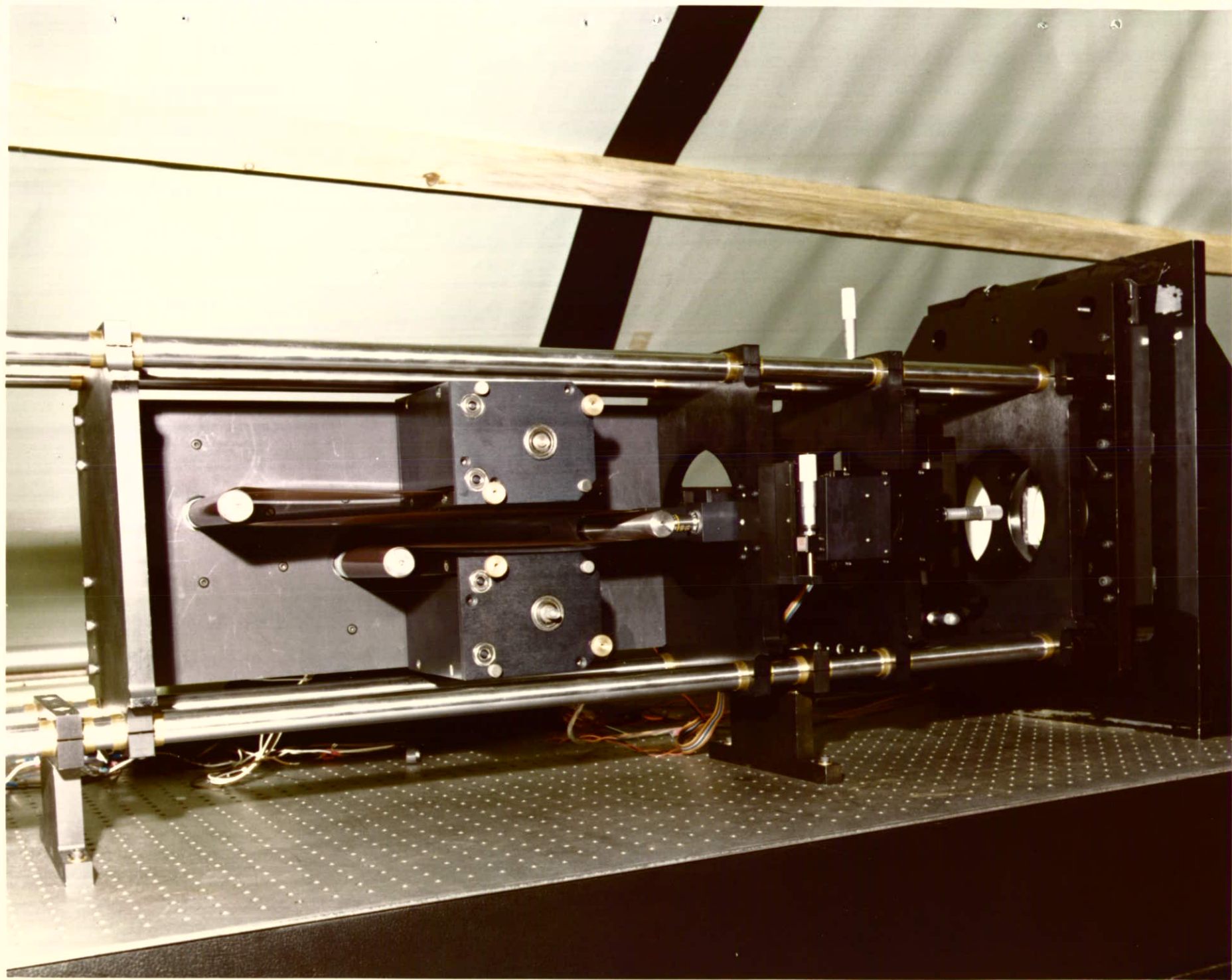

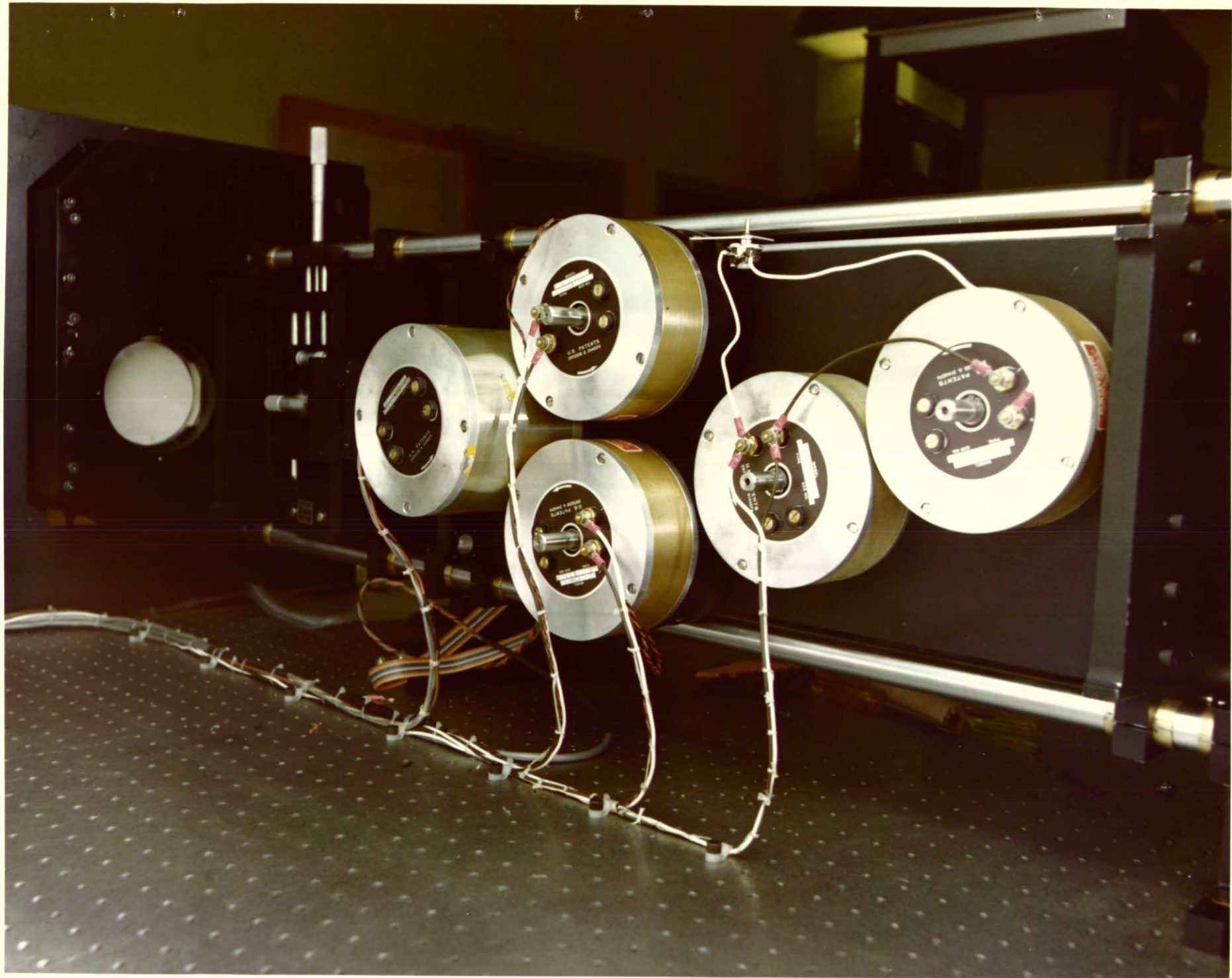

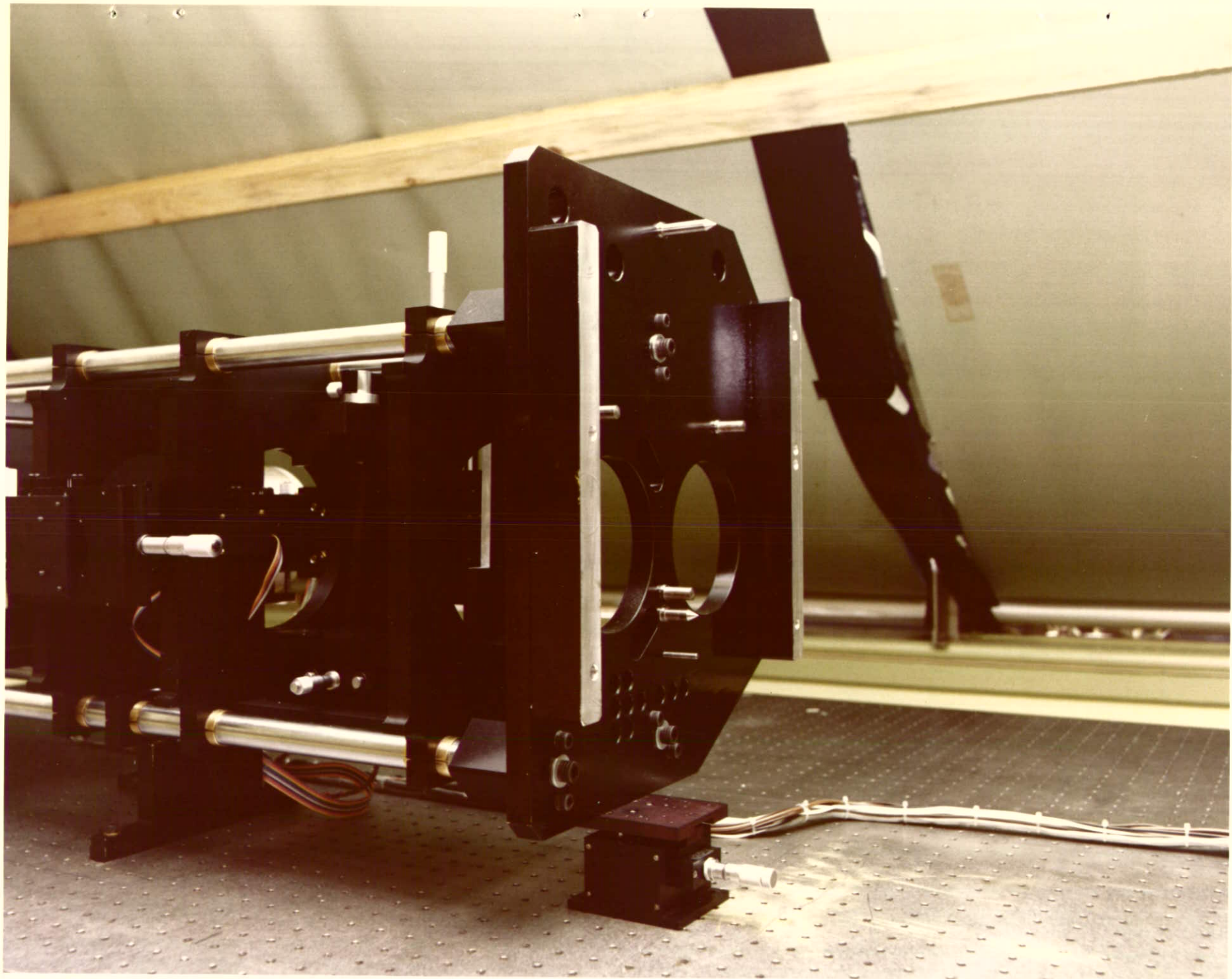

DOCUMENT CONTROL DATA - R & D

(Security classification of title, body of abstract and indexing annotation must be entered when the overall document is classified)

1. ORIGINATING ACTIVITY Defence Research Establishment Ottawa Shirley Bay, Ottawa, Ontario K1A 0Z4		2a. DOCUMENT SECURITY CLASSIFICATION Unclassified	
		2b. GROUP	
3. DOCUMENT TITLE The Mechanical Engineering Design of the DREO Optical Recorder for SEASAT.			
4. DESCRIPTIVE NOTES (Type of report and inclusive dates) DREO Tech Note 79-14, September 1979			
5. AUTHOR(S) (Last name, first name, middle initial) Hudson D.J., Pede V.H.			
6. DOCUMENT DATE September 1979		7a. TOTAL NO. OF PAGES 27	7b. NO. OF REFS 2
8a. PROJECT OR GRANT NO. 33D00		9a. ORIGINATOR'S DOCUMENT NUMBER(S)	
8b. CONTRACT NO.		9b. OTHER DOCUMENT NO.(S) (Any other numbers that may be assigned this document)	
10. DISTRIBUTION STATEMENT Unlimited			
11. SUPPLEMENTARY NOTES		12. SPONSORING ACTIVITY	
13. ABSTRACT <p>This paper contains a description of the mechanical engineering aspects of the DREO optical recorder for SEASAT. The concept, design and construction are discussed in detail.</p> <p>The device receives a signal from the satellite and converts it into an intensity -modulated line on an oscilloscope. This line is focussed by a lens system on to a moving film. The motion of the film allows an image to build up. The speed and tension of the film are controlled by servomotors.</p> <p>The recorder functioned well and produced valuable information before the failure of SEASAT.</p>			

KEY WORDS

- optical processing
- precision engineering
- satellite receivers
- film recording

INSTRUCTIONS

1. **ORIGINATING ACTIVITY:** Enter the name and address of the organization issuing the document.
- 2a. **DOCUMENT SECURITY CLASSIFICATION:** Enter the overall security classification of the document including special warning terms whenever applicable.
- 2b. **GROUP:** Enter security reclassification group number. The three groups are defined in Appendix 'M' of the DRB Security Regulations.
3. **DOCUMENT TITLE:** Enter the complete document title in all capital letters. Titles in all cases should be unclassified. If a sufficiently descriptive title cannot be selected without classification, show title classification with the usual one-capital-letter abbreviation in parentheses immediately following the title.
4. **DESCRIPTIVE NOTES:** Enter the category of document, e.g. technical report, technical note or technical letter. If appropriate, enter the type of document, e.g. interim, progress, summary, annual or final. Give the inclusive dates when a specific reporting period is covered.
5. **AUTHOR(S):** Enter the name(s) of author(s) as shown on or in the document. Enter last name, first name, middle initial. If military, show rank. The name of the principal author is an absolute minimum requirement.
6. **DOCUMENT DATE:** Enter the date (month, year) of Establishment approval for publication of the document.
- 7a. **TOTAL NUMBER OF PAGES:** The total page count should follow normal pagination procedures, i.e., enter the number of pages containing information.
- 7b. **NUMBER OF REFERENCES:** Enter the total number of references cited in the document.
- 8a. **PROJECT OR GRANT NUMBER:** If appropriate, enter the applicable research and development project or grant number under which the document was written.
- 8b. **CONTRACT NUMBER:** If appropriate, enter the applicable number under which the document was written.
- 9a. **ORIGINATOR'S DOCUMENT NUMBER(S):** Enter the official document number by which the document will be identified and controlled by the originating activity. This number must be unique to this document.
- 9b. **OTHER DOCUMENT NUMBER(S):** If the document has been assigned any other document numbers (either by the originator or by the sponsor), also enter this number(s).
10. **DISTRIBUTION STATEMENT:** Enter any limitations on further dissemination of the document, other than those imposed by security classification, using standard statements such as:
 - (1) "Qualified requesters may obtain copies of this document from their defence documentation center."
 - (2) "Announcement and dissemination of this document is not authorized without prior approval from originating activity."
11. **SUPPLEMENTARY NOTES:** Use for additional explanatory notes.
12. **SPONSORING ACTIVITY:** Enter the name of the departmental project office or laboratory sponsoring the research and development. Include address.
13. **ABSTRACT:** Enter an abstract giving a brief and factual summary of the document, even though it may also appear elsewhere in the body of the document itself. It is highly desirable that the abstract of classified documents be unclassified. Each paragraph of the abstract shall end with an indication of the security classification of the information in the paragraph (unless the document itself is unclassified) represented as (TS), (S), (C), (R), or (U).

The length of the abstract should be limited to 20 single-spaced standard typewritten lines; 7/8 inches long.
14. **KEY WORDS:** Key words are technically meaningful terms or short phrases that characterize a document and could be helpful in cataloging the document. Key words should be selected so that no security classification is required. Identifiers, such as equipment model designation, trade name, military project code name, geographic location, may be used as key words but will be followed by an indication of technical context.