

RESEARCH AND DEVELOPMENT BRANCH
DEPARTMENT OF NATIONAL DEFENCE
CANADA

DEFENCE RESEARCH ESTABLISHMENT OTTAWA

DREO TECHNICAL NOTE NO. 80-26
DREO TN 80-26

THE LOW TEMPERATURE CHAMBER TESTING OF THE COMPRESSION IGNITION ENGINE AND SYSTEM OF THE ARMOURED PERSONNEL CARRIER (APC) M113A1

by
G.D. Webster, R.G. Glass and G.J. Hutton



PROJECT NO.
25B00

JUNE 1981
OTTAWA

CAUTION

This information is furnished with the express understanding that proprietary and patent rights will be protected.

RESEARCH AND DEVELOPMENT BRANCH

DEPARTMENT OF NATIONAL DEFENCE
CANADA

DEFENCE RESEARCH ESTABLISHMENT OTTAWA

TECHNICAL NOTE NO. 80-26

THE LOW TEMPERATURE CHAMBER TESTING OF THE COMPRESSION IGNITION
ENGINE AND SYSTEM OF THE ARMoured PERSONNEL CARRIER (APC) M113A1

by

G.D. Webster, R.G. Glass and G.J. Hutton
Energy Conversion Division

PROJECT NO.
25800

JUNE 1981
OTTAWA

ABSTRACT

A study has been undertaken to validate and supplement data observed during the February 1978, Alert (NWT) low temperature starting tests for the Canadian Forces Armoured Personnel Carrier M113A1. The cold chamber testing found the M113A1 compression ignition (CI) GMC6V53 engine to have a somewhat reduced starting capability than was observed for the Arctic testing. The "No-Start Temperatures- T_{NS} " using #10 oil and type AA fuel for the tests of this study was $T_{NS} \geq -20^{\circ}\text{C}$ ($T_{NS} \geq -20^{\circ}\text{C}$ for the Arctic Tests). It is believed that traces of water vapour in the fuel may have contributed to this discrepancy. The T_{NS} for the Arctic grade synthetic oil DN 600 and Type AA fuel was $T_{NS} \geq -22^{\circ}\text{C}$.

The report describes in detail the systems used for instrumentation, experimentation and data analysis. This detail has been provided to assist those that wish to continue the work of this study.

A number of conclusions have been drawn and recommendations made for areas of required future effort. The report is concluded with an overall general discussion that summarizes and suggests an approach to improve the cold starting capability of CF compression ignition combat vehicle powerplants.

RÉSUMÉ

Une étude a été entreprise pour vérifier et compléter les données observées en février 1978 à la station Alert (T.N.-O.), lors des essais de démarrage à basse température qu'on a fait subir au véhicule de transport de troupes M113A1 des Forces canadiennes. Les essais en chambre froide ont démontré que le moteur à auto-allumage GMC6V53 du M113A1 a une capacité de démarrage légèrement inférieure à celle qui avait été observée lors des essais dans l'Arctique. En effet, en utilisant de l'huile #10 et du carburant de type AA, on a obtenu une "température limite de démarrage" (T_{NS}) de $\geq -20^{\circ}\text{C}$, tandis que dans l'Arctique, ce même essai avait donné: $T_{NS} \geq -22^{\circ}\text{C}$. Cet écart pourrait s'expliquer en partie, semble-t-il, par les traces de vapeur d'eau trouvées dans le carburant. En utilisant de l'huile synthétique de qualité arctique DN 600 et du carburant de type AA, on a obtenu: $T_{NS} \geq -22^{\circ}\text{C}$.

Le rapport décrit en détail les systèmes utilisés pour l'analyse des instruments de bord, des expériences et des données. Ces détails ont été fournis pour aider ceux qui voudraient poursuivre l'étude.

Un certain nombre de conclusions ont été tirées et des recommandations ont été faites en ce qui a trait aux aspects sur lesquels devraient porter les efforts futurs. La conclusion du rapport consiste en un examen d'ensemble qui résume la situation et suggère une approche susceptible d'améliorer la capacité de démarrage à froid des véhicules de combat des FC équipés d'un moteur à auto-allumage.

UNCLASSIFIED

TABLE OF CONTENTS

	<u>Page</u>
<u>ABSTRACT/RÉSUMÉ</u>	iii
<u>TABLE OF CONTENTS</u>	v
<u>INTRODUCTION</u>	1
<u>TEST PROGRAMME OBJECTIVES</u>	3
<u>TEST PROGRAMME</u>	4
<u>TEST MONITORING INSTRUMENTATION</u>	4
<u>TEST PROGRAMME DETAILS</u>	5
<u>TESTING DESCRIPTION</u>	6
<u>ANALYSIS AND DISCUSSION OF DATA</u>	6
<u>CONCLUSIONS RECOMMENDATIONS AND DISCUSSION</u>	15
<u>GENERAL DISCUSSION AND RELATED RECOMMENDATIONS</u>	18
<u>REFERENCES</u>	21
<u>ABBREVIATION LIST</u>	24
<u>FIGURE LIST</u>	26
<u>LIST OF APPENDICES</u>	46

INTRODUCTION

Low temperature starting problems with the compression ignition (CI)* engine were observed soon after initial automotive and aircraft diesel development. Fuel wax crystal formation was found to clog fuel lines and filters at temperatures lower than -12°C .

Macroscopic engine combustion processes for the CI engine have been comprehensively understood since before the 1930's. Richardo (1)** discussed the three phases of combustion:

1. delay period,
 2. period of rapid combustion,
 3. completion of combustion.
- } Figure 1[†] illustrates these phases.

The delay period was found to depend primarily upon the nature of the fuel with lesser dependancy on compression ratio, air preheating and fuel droplet size. The period of rapid combustion is influenced by the combustion chamber turbulence, the amount of fuel present in the cylinder and the air-fuel mixture properties. During the completion of combustion phase the mixture burning is under direct mechanical control where the pressure can be varied by altering the rate of injection.

Early researchers found that certain changes to the chemical composition of the fuel, by the addition of particular additives, had the effect of shortening the delay period. Shortening the delay period reduced the cranking time before ignition occurred. This improvement was accompanied by the disadvantage of an increased temperature of fuel wax crystal formation. As a result of these efforts a quantitative classification of fuels according to ignition quality was adopted and called the cetane*** number rating.

* Abbreviation list at end of main body of report. Page No. 24
** Numbers in parenthesis designate references at the end of the paper.
† Figures 1 to 16 along with Tables 1, 2 and 3 can be found in the main part of the report following the abbreviation list. For the readers convenience Figures 17-24 have been included with the Analysis and Discussion of Data Section in the report main body.
*** For a brief explanation of cetane number see Appendix I.

More recently in work similar to that of Feldman (5) investigators concluded that certain other additives limited the size of fuel wax crystal growth. The growth was inhibited to such a degree that the wax crystals could pass through the conventional filters at temperatures significantly below the cloud point** and pour point†. Before the above findings were observed it was suggested that low cetane number fuels could be used to avoid wax crystal formation. To do this combustion chamber preheat devices would be needed as the cold starting capability would be reduced using the lower cetane number fuels. This hypothesis was quickly criticized due to a significant increase in engine deposits (6) when lower cetane number fuels were used.

With the use of fuel additives further improvement to cold starting capability necessitated a more comprehensive study of combustion chamber phenomena. To burn efficiently, a diesel fuel should atomize properly, ignite quickly and burn completely.

Diesel fuel volatility influences both injection and distribution. If the fuel contains too much volatile material at the temperature it reaches during injection into a hot combustion chamber too much of it will vaporize quickly. This will result with penetration into the combustion volume falling short of the requirement for good mixing. Hence, if a more volatile fuel is used to improve cold starting then a sacrifice has to be made in less efficient combustion at operating temperatures.

Another approach to improve low temperature starting of the CI engine was to increase combustion chamber temperatures. Many starting aids have been suggested and tested to achieve this goal: coolant heating (7), glow plugs (8), battery heating (9, 10, 11), volatile gas addition (12), low voltage ignition (13), intake air preheating (14), block-lubricant heaters (15) and thermosyphons (16).

Starting aids usually assist at an expense. For instance the use of immersion heaters requires a substantial power source (approximately 1500 watts) to be in the vicinity of the vehicle. The starting with volatile gas addition (as an example, ether) has problems associated with engine wear due to the explosive nature of the combustion. Ether addition also has the problem of possible over-injection causing serious engine damage due to the explosion. Even air flame preheating has the problem of overheating where too much oxygen is used, making combustion of the fuel inside the chamber marginal to impossible.

Bowhay (17) has comprehensively looked at the complex problem of CI engine deposits at low temperatures and poses recommendations to the fleet vehicle user. Austen and Lyn (18) have treated the cold starting problem from a basic experimental approach. They have used pressure transducers and responsive thermocouples to measure combustion chamber temperatures and

** Cloud point (T_c) is that temperature at which wax crystals noticeably begin to precipitate out of the fuel.

† Pour point (T_p) is that temperature at which the entire fuel mass, solid and liquid, freezes and ceases to flow or be poured $T_c - T_p \approx 5$ to 10°C
 $T_c > T_p$.

pressures during cranking. Detailed aspects of Austen's paper are discussed in the Data Analysis Section.

From the literature there is an apparent lack of information on solutions to cold starting problems utilizing present technology. The 1978 winter low temperature testing of the Armoured Personnel Carrier (APC M113A1) at Canadian Forces Station Alert (19) indicated that this vehicle's no-start temperature was $T_{NS} \geq -22^{\circ}\text{C}$ with SAE #10 oil. The 1978 summer cold chamber testing for the 2-1/2 ton truck replacement programme at the National Research Council (NRC) (2) demonstrated that only two vehicles could start at vehicle bulk temperatures of $\bar{T}_V = -25^{\circ}\text{C}$. Marginal starts for these 2 vehicles were expected for temperatures lower than $\bar{T}_V = -30^{\circ}\text{C}$. This indicates that the hypothesis mentioned in (19), namely, "The Canadian Forces (CF) Have a Starting Problem", is valid for CI powerplants at temperatures lower than -30°C . This report will endeavour to shed more light on this hypothesis.

TEST PROGRAMME OBJECTIVES

1. To further substantiate the no-start temperature (\bar{T}_{NS}) for the Armoured Personnel Carrier (APC) M113A1 with cold chamber testing using SAE #10 oil and a synthetic oil (Fina) DN600.
2. To further investigate the 3 phases of combustion as they relate to combustion pressures.
3. To further investigate the identification in real time of engine initial self-cranking or initial operation.
4. To further evaluate and compare the proposed "Mini Starting Test Package" (19), with the more detailed tests of this study.
5. To further examine the battery heating and insulation characteristics of M113A1.
6. To establish the limitations of the Air Box Heater, the intake air preheat system for the M113A1.
7. To compare the cooling rates observed for ambient Arctic testing with cold chamber testing.

In addition to reporting the investigation for the above objectives, this report has endeavoured to fulfill a secondary objective. At the request of DRES personnel visiting DREO (Dec 78) many of the details such as the "Instrumentation Wiring Diagrams" of Appendix II have been included. This has been done to facilitate transfer of the DREO "Low Temperature Programme" to DRES.

TEST PROGRAMME

A CF Armoured Personnel Carrier (APC) M113A1 was used as a test vehicle representative of CF present and future compression ignition (CI) engines. The CI powerplant for the APC is a GM6V53 powerplant with a displacement of (318 in³). Additional engine system specifications for this powerplant can be found in Appendix III.

The parameters measured and their locations for the M113A1 system are shown in Figures 1, 2 and 3 of Appendix IV. The fuel flow, Figure 4, Appendix IV, was measured by a (Fluid dyne) positive displacement flow transducer. The intake air flow rate was measured by a vane type (Autotronics) pressure compensated flow device. The electrical currents were measured by shunts, as in Figure 5, Appendix IV. The voltages were measured at the shunt locations with respect to the system ground. The pressure transducer location in the cylinder head amongst the valve gear, injector, waterjacket, oil galleries and oil drains can be seen in Figure 6, Appendix IV. The cylinder pressure pulses when counted over a known time period yielded an average value of RPM for that period.

The "Mini Starting Test Package" developed for CF candidate vehicle testing of low temperature starting capability was tested further in these tests. This "package" is shown and described in Appendix V.

TEST MONITORING INSTRUMENTATION

The instrumentation wiring harness in the van portion of the 1-1/4 ton truck (Figure 2) was completely rewired after the 1978 arctic winter testing programme (19). The new wiring harness employed quick connect-disconnect multipin connectors to facilitate trouble shooting and instrumentation repair. The new wiring system with improved shielding is shown in Appendix II.

The instrumentation rack on the left in Figure 3 contains on the top a wire junction box called "Distribution Box A" in Appendix II. Below the distribution box is a (Sanders ADR II) data acquisition system used for recording of temperatures (see Appendix VI for details on the Sanders ADR II and data massaging system). Beneath the data acquisition system a (Doric) trendicator has been employed with a rotary switch to give instantaneous digital temperature readouts for up to 40 channels. A digital clock has been installed below the trendicator to monitor cold soak duration in total hours. A portable quartz (Seiko) clock monitored real time and was checked weekly against the NRC standard. On the rack bottom is a (Hycal 305) thermocouple temperature reference junction. At the top of the rack on the right in Figure 2 is the 18 channel distribution panel called "Distribution Box B". Beneath "Box B" is the 8 channel half inch (S.E. labs) tape recorder.

The third rack is shown in Figure 4. Contained at the top are the digital displays for fuel flow (Fluid dyne) and air flow (Autotronics) transducers. Each transducer's digital display unit has an analog output that enabled recording on the tape recorder or the 8 channel (Gulton) chart recorder shown on the bottom of the rack in Figure 4.

The thermal electrical signals sensed by the "T" type thermocouples and the electrical transducer signals all from the vehicle soaking in the cold chamber entered the instrumentation vehicle at the wall mounted junction box Figure 5.

Audio communication between the instrumentation vehicle and the starting officer (that person in the cold soaked vehicle performing engine cranking) was carried out via (Fannon) intercom. This dialogue was recorded on the audio channel of the 8 channel tape recorder.

TEST PROGRAMME DETAILS

Eleven cold chamber tests were performed on the M113A1. The first four in June and the remaining seven in August of 1978. Due to problems with the air preheat system, namely the air box heater (ABH) the first four tests cannot be considered the vehicles' best efforts at starting. The first nine tests used SAE #10 oil and the remaining two tests (10 and 11) were carried out with a commercially available synthetic oil (Fina) "polar start", DN600. The fuel used throughout the testing was "Arctic Grade Diesel Fuel"3-GP-6M Type AA (see Appendix III for fuel-engine specifications). (For fuel analysis results see Appendix IX).

Due to the importance of maintaining the batteries at known conditions, a series of specific gravity tests were carried out with five different types of hydrometers. One particular wide bodied hydrometer that gave significantly more consistent results throughout the tests was chosen over the remaining four. This hydrometer was used to record the batteries' specific gravity for all twelve cells just after engine warmup and immediately prior to engine cranking. On no occasion was there more than a five percent difference in specific gravities between battery cells. The engine was given a warm-up for battery charging and combustion chamber deposit removal purposes at approximately 1250 RPM for a period that usually exceeded 45 minutes but not more than 60 minutes. Tests 1-4 used batteries that had been in service for 6 months; Tests 5-11 used new batteries.

The batteries were insulated for all tests and heated with a resistive type heater for tests, 9, 10 and 11. (For heating and insulation details see Appendix VII). To reduce conductive heat loss from the battery box via the battery cables switches were installed just outside the battery box.

The conditions pertaining to each test are listed in Table 1 and the salient test results are listed in Table 2 (the tables follow Figure 5 at the end of the report). The measurements and the systems used for their recording are tabulated in Appendix IV.

During the period between the two test sessions of June and August a coolant heater was installed on the M113A1. The kit was installed without the battery heating portion. After the unsuccessful start of Run 1 Test 6 the coolant heater was used to heat the system for a successful start.

The "Arctic clutch" when disengaged removed the load on the starter motor that would have been required to turn the transmission during cranking. The clutch, as can be seen in Table 1, was disengaged for all tests except test 7.

UNCLASSIFIED

The time between initial cold chamber compressor activation and vehicle starting was recorded as the "cold soak time". During this period the temperatures were recorded by hand on an hourly basis and by the Sanders ADR II cassette recorder (see Appendix VI) at 10 minute intervals. The plotted cooling curves of these cold soak periods are shown in Figure 6 to 16. For simplicity only the most essential 6 to 22 temperatures were plotted.

TESTING DESCRIPTION

After the cold soak period when the desired temperatures had been reached, cranking preparations were undertaken. The starting officer (SO) checked all fluid levels and air box heater pressures. The instrumentation officer (IO) measured and recorded battery cell specific gravities. The chart recorder calibration was carried out on all 8 channels. All instrumentation was activated by the IO and a final set of temperatures was taken. A check list was read through by the IO to the SO in the test vehicle via intercom (all pre-start verbal discussion was recorded on the audio channel of the tape recorder). If all facets checked, a starting countdown was initiated by the IO so that zero of the countdown coincided with a known real time. At zero of the countdown the SO closed the vehicle master switch (battery cable switches were closed just before the countdown 10 to zero was initiated). The air box heater was then activated for a period of 2 to 4 seconds followed by a 2 second wait before cranking commenced. The fuel cut-off valve was open (or in the "in" position). The IO then recorded the actual time of initial cranking. All starting dialogue between IO and SO was recorded on the tape recorder along with cylinder pressure for future correlation with the chart recordings. Cranking was continued with the air box heater activated at the discretion of the SO. The percentage of air box heater usage during cranking varied from 50 to 80% of the time. If the cranking speed was increasing or remaining constant at some value greater than 100 RPM, cranking was continued for up to 180 seconds. The significance of the 180 seconds was based on unsubstantiated evidence of initial overheating by the starter motor at low temperatures after longer cranking periods. Thermocouples were not attached to the starter motor due to its inaccessible location.

ANALYSIS AND DISCUSSION OF DATA

The pertinent test data are tabulated in Tables 1 and 2 (p. 32, 33). In analyzing the paper chart recordings of starting attempts the most subjective measurement is determining when starting occurred. For the data accumulated during the 1978 CFS Alert trials (henceforth referred to as Alert data) (19), a voltage line method was utilized to locate vehicle starting. (The paragraph in the report discussing this method has been included in Appendix VIII.) Engine cycling without starter motor assistance only occurred when the starter button was released. The SO who has great difficulty audibly distinguishing whether the engine has sufficient heat and inertia releases the starter button only when he is certain the engine will not stall. The deduced question queries, what is the lowest RPM for unassisted engine cycling? The Alert trials indicated that stall RPM using the fuel cut-off valve was between 200 and 300 RPM. More recent fuel cut-off stall tests using voltage drop, pressure regime changes and analog RPM indicated the stall to be of approximately 180

UNCLASSIFIED

RPM. One would expect the stall RPM to be higher than the initial self cycling (ISC) RPM due to the inertial effects of restrained combustion as the fuel is gradually cut-off.

In the tests for this study, it was observed that by taking the point in time of initial noticeable voltage smoothing, the corresponding RPM was approximately 150. This point of voltage smoothing is reasonably well defined. The question can be raised as to the difference of 50 RPM between the low level of 200 RPM for the previous voltage line method (Appendix VIII) and the 150 RPM from the analog rpm. The answer lies in the method of RPM measurement, the values found for the Alert data were the result of a measurement of time between the pulses on either side of the voltage line. This measurement resulted in a higher RPM reading than is indicated by the analog RPM transducer. Both measurements are averages but the analog RPM is updated more frequently, hence it tends to better reflect the velocity increase.

Figure 17 illustrates the use of the above approach for test number 7. The window of chart recorder information describes the analog parameter behaviour during cranking. It should be noted that the airflow trace follows the analog rpm trace considerably better than predicted for the discussion in Appendix VIII.

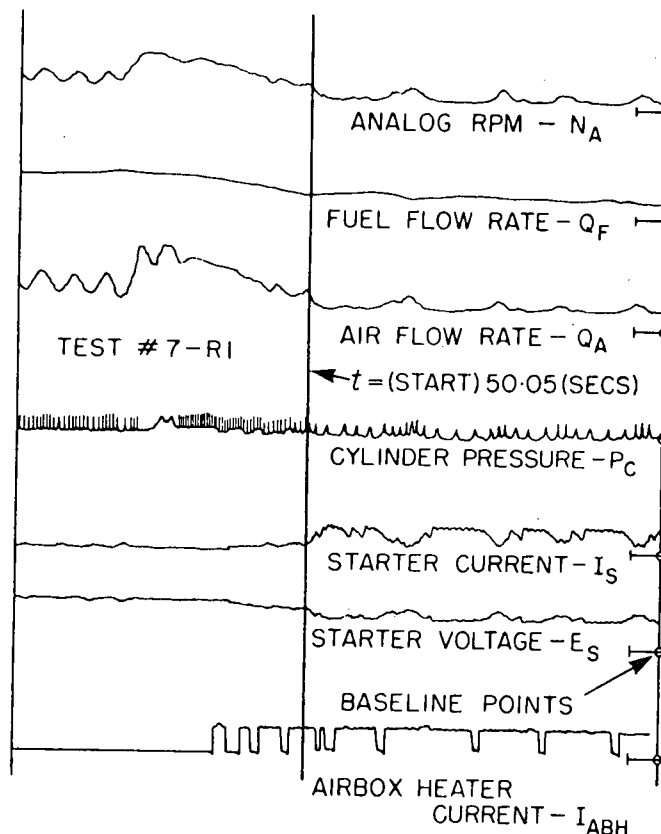

Fig. 17: Chart recording for test 7, utilizing the revised voltage line method.

Using the revised voltage line method the number of cranking cycles and cranking times were determined. The number of cycles to start is plotted in Figure 18 as a function of vehicle bulk temperature \bar{T}_V . Before discussing

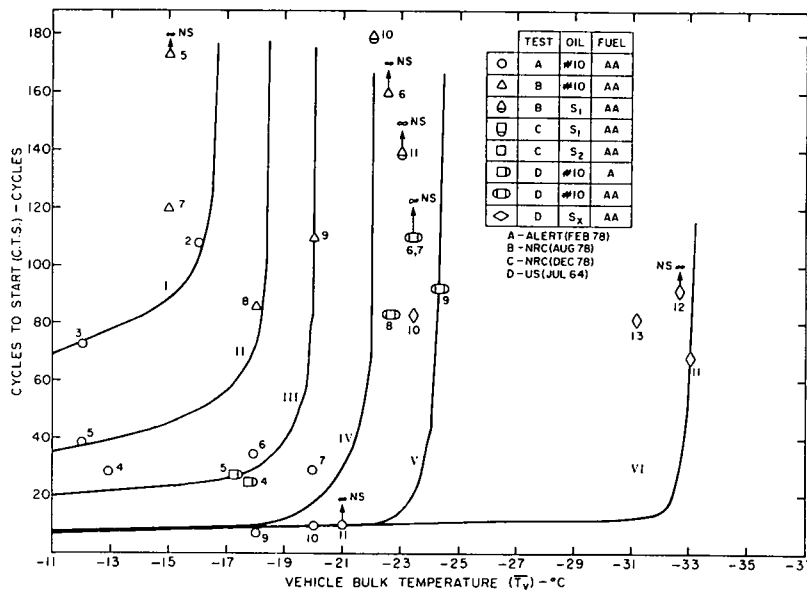

Fig. 18: Relationship between cycles to start and vehicle bulk temperature.

Figure 18 in detail further background information relative to it is given. In the Alert data, an arithmetic temperature average was used to establish \bar{T}_V . For the cold chamber tests more precise environmental control was possible, consequently vehicle temperatures were allowed to approach the ambient temperatures. The battery temperatures were kept above -20°C . It was recommended (19) that some type of battery heating should be used for Northern operation that would keep the battery temperature in the range of -15 to -20°C . By keeping the battery temperatures within this range and providing an adequate oil viscosity that allowed initial cranking velocity in excess of 100 RPM, the batteries could provide enough energy for cranking times in excess of 180 seconds. This would make the starter motor the limiting factor, and not the batteries. Thus avoiding excessive battery discharge. It should also be noted when comparing the system temperatures of the Alert data Appendix VIII with the cold chamber temperatures Tables 1 and 2, that an effort was made to duplicate the Alert conditions. This accounts for the intentional depressed cold chamber ambient temperatures T_A relative to \bar{T}_V , that were recorded, just prior to a cranking attempt. In summary, \bar{T}_V of Figure 18 reflects all vehicle temperatures with the exception of the battery temperatures and the ambient temperature T_A . At starting \bar{T}_V was equal to T_{EO} in Table 1 and 2.

Each symbol in Figure 18 and its identification number refers to an individual cranking attempt for a series of tests. Tests labelled NS refer to a "NO START" condition. The graph inset key describes the four series of tests A to D. Also shown are the lubricating oils and the fuel grades used for each cranking attempt. For the lubricating oils #10 refers

to SAE #10 lubricating oil and S₁, S₂ and S_x refer to synthetic lubricating oils. For the fuels, A refers to sub-Arctic winter grade fuel and AA refers to Arctic winter grade fuel. The replotted Alert* data, Series A, is shown as curves I, II, III and IV in Figure 18. Curve I as in Figure 1 and 2 of Appendix VIII reflects the Canadian Forces starting procedure - CSP. Curve II utilizes CSP and the air box heater - ABH. Curve III incorporated the arctic clutch - AC. Finally curve IV shows the effects of using a new starting procedure - NSP and battery heating for test #9 - BH #9. The points with infinity signs above the arrows indicate that to start the vehicle would have taken a time or number of cycles approaching infinity had cranking been continued with an infinite capacity power source.

The August tests, Figure 18, have a somewhat higher number of cycles than the replotted Alert data. Test 7 had the arctic clutch engaging the transmission to the engine creating greater opposition to cranking. This explains the greater number of cycles required for the relatively high bulk temperatures $\bar{T}_v = -14^\circ\text{C}$. The reasons for the somewhat higher temperature and cycle values of tests, 8, 9 and 10 was first thought to be fuel degradation. A fuel analysis carried out by the National Research Council, Fluids and Lubricants Laboratory, during December 1978 revealed no fuel degradation other than a presence of condensed water vapour as indicated by a high freeze point of -18°C . A comprehensive discussion of the fuel analysis has been inserted as Appendix IX.

Fuel filter clogging by ice crystals was next considered. This possibility was dismissed due to flow being recorded on the injector side of the filters by the fuel flow transducer. It was then postulated that ice crystals were forming in the injectors and reducing the effectiveness of the spray pattern in the combustion chamber. Discussions with Detroit Diesel (Allison Division of General Motors) indicated this possibility to be highly unlikely. The filter inside the injector is more coarse than the main upstream filters. It is unlikely that the high injector pressures > 1000 psi would permit ice crystals to form or be present after one or two cranking cylinder compressions. Hence at this time no explanation can be given for the lower than expected starting capability. Low temperature bench tests could be carried out with different quantities of condensed water vapor present in the fuel on an injector test stand** for specific parameter variation while monitoring the spray patterns.

* The Alert data here has been replotted for engine oil temperature being used as the vehicle bulk temperature. (This accounts for any differences detected from Figure 1 and 2 of Appendix VIII.)

** The injector test stand is standard DND equipment for maintaining the Detroit Diesel injectors.

Figure 18 also has plotted on it data from similar 1964 US Army M113 (21) cold chamber tests (see Appendix X). The data corresponds to curves V and VI. These points reflect the starting capability of another M113 for three similar combinations of lubricating oil and fuel. It is interesting to note how well test #10 (Alert data) corresponds to curve V for similar oils and fuels. If it were possible to have the duplicated conditions of test #10 in the cold chamber, starting capability corresponding to curve V might be expected.

Curve IV represents the M113 starting capability with a SAE #10 lubricating oil. Considering the point for test #10 (Alert data) and the US tests it appears reasonable to expect curve IV to be closer to curve V. Similar fuels and lubricating oils were used for both tests.

In comparing curves IV, V and VI a possible explanation should be given for the scatter present for US tests 11, 12 and 13. It is known that the percentage of time the airbox heater (ABH) was activated is directly proportional to the number of cycles to start. From Appendix X it can be seen that test 13 had ABH activation for only 51.2% of the cranking time and test 11 had activation for 73.4% of the time. This caused combustion temperatures to be reached in a shorter time. The same conclusions can be reached for tests 8, 9 and tests 4, 5. It appears the length of time the ABH is activated becomes an increasingly more important factor affecting cold starting as T_v decreases. This corresponds to observations for the Alert data.

Also plotted on Figure 18 are points from the DREO, December 1978 cold chamber trials. This was an extension of the present study to investigate more thoroughly the effects of vehicle battery recharging and uses of synthetic oils. The study was carried out by G.J. Hutton, L. Brossard and L. Gallop (22). The points for the December 1978 tests reflect even greater resistance to starting than experienced during the summer trials. The cycles to start were obtained for the average RPM and the cranking time. These values and the US values are not an actual summation of engine cranking cycles.

The similar curves obtained for the cranking times (Figure 19) reflect the consistency of using either the cranking time or cycles as a means for comparative purposes.

In Figure 19 the point for test #10 Aug 78 is on curve IV as in Figure 18. Synthetic oil was used for this test which should have improved the starting capability yielding results closer to curve VI.

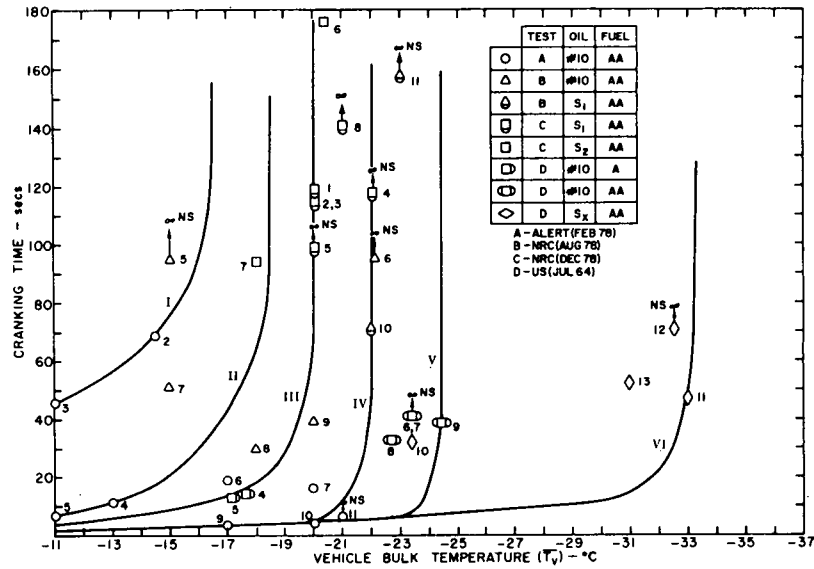

Fig. 19: Relationship between cranking time and vehicle bulk temperature

It was thought from the Alert tests that the combination of cycles to start and the cranking time which yields the average cranking RPM was a more meaningful mode for analysis (Figure 20).

As can be seen in Figure 20 the point for test #10 Aug 78 indicates the synthetic oil had the desired effect of increasing the average cranking RPM. Primary combustion conditions were not present for autoignition to occur earlier in time.

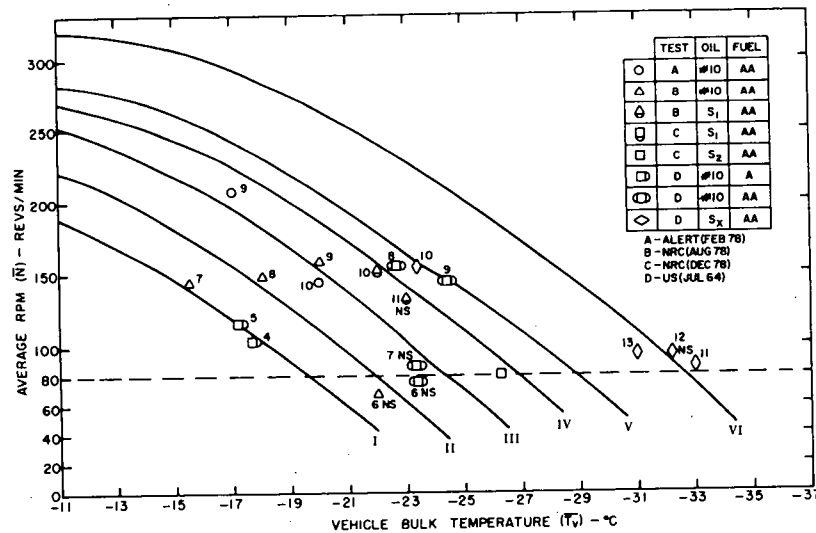

Fig. 20: Relationship between average cranking RPM and vehicle bulk temperature

UNCLASSIFIED

The further testing for this report and the type of plots produced for Figure 20 has indicated analysis is clearer from either Figure 18 or Figure 19. The major benefit from using this plot (Figure 20) as an analytical tool is its ability to provide an average RPM up to the time just before cranking was discontinued for the no start cases. Fixed values for no start conditions are not possible for Figure 18 and 19. The dotted line at 80 RPM indicates an average value beneath which starting is not likely to occur. Again six characteristic curves are evident that correlate to Figures 18 and 19. It should be noted that further testing would be required to completely substantiate these curves. It is not expected however, that further testing would significantly alter the placement or shape of the curves of Figures 18, 19 and 20. These curves are similar in shape to those of other researchers (23).

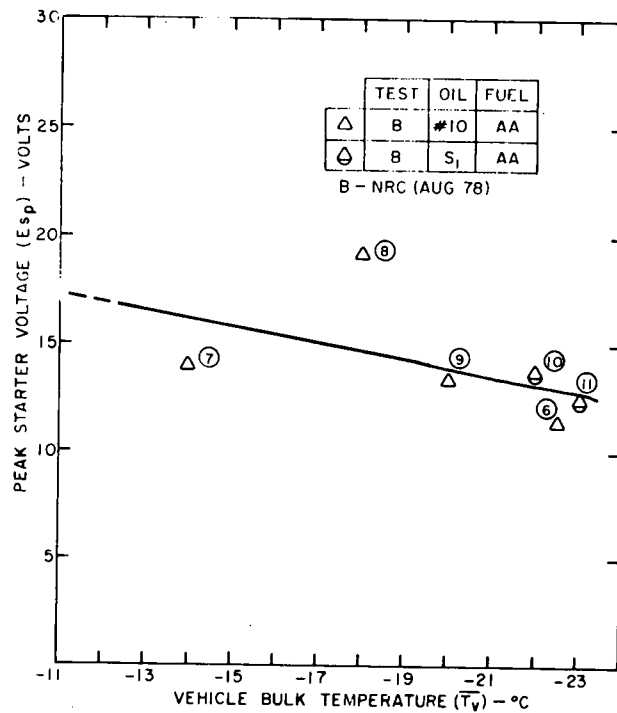

Fig. 21: Relationship between peak starter voltage and vehicle bulk temperature

UNCLASSIFIED

Figure 21 illustrates the decreasing nature of peak minimum starter voltage E_{Sp} with decreasing \bar{T}_V . It is interesting that the peak minimum starter voltage dropped to a low 14.0 volts for test 7. This indicated the difficulty the starter motor was confronted with trying to move the engine and transmission while the arctic clutch was engaged. It is thought that a calibration error for test #8 produced the inordinately high value of 19.6 volts. It was found for pre-test trials at $\bar{T}_V = -10^\circ\text{C}$ that the peak starter voltage E_{Sp} was 18.0 volts. This permitted the above curve to be drawn as indicated.

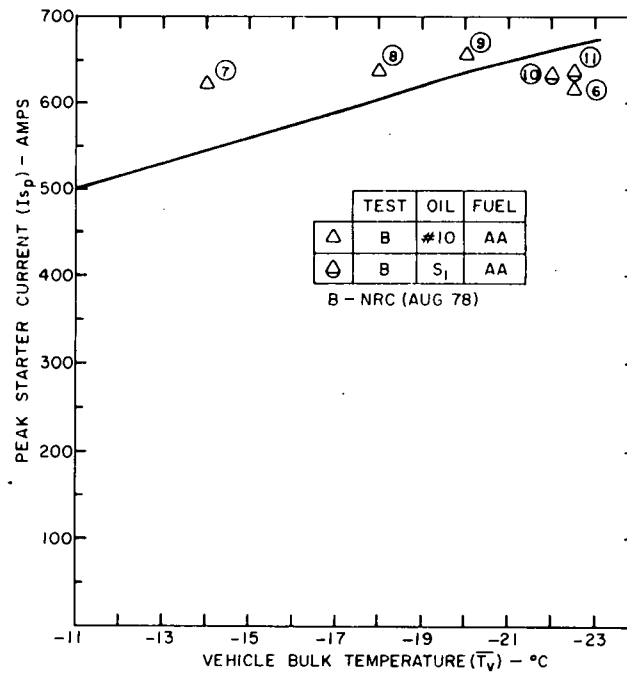

Fig. 22: Relationship between peak starter current and vehicle bulk temperature

Figure 22 depicts the behaviour of peak maximum starter current with decreasing vehicle bulk temperature. Once again the value for test 7 is high due to the increased opposition to cranking as a result of the arctic clutch being engaged. It was also found from pre-test trials at $\bar{T}_V = -10^\circ\text{C}$ that the peak starter current I_{Sp} was 480 Amperes. This forced the data to assume a curve shape similar to that shown.

The decreasing cylinder pressure with decreasing vehicle bulk temperature is shown in Figure 23. One would have expected the point for test 7 to be somewhat lower. The value shown is within acceptable scatter limits for this type of measurement. The cylinder pressure decreases with decreasing temperature due to the reduced ambient air temperature at the air intake. This seems to occur despite better sealing at the ring wall interface as a result of depressed ambient temperatures.

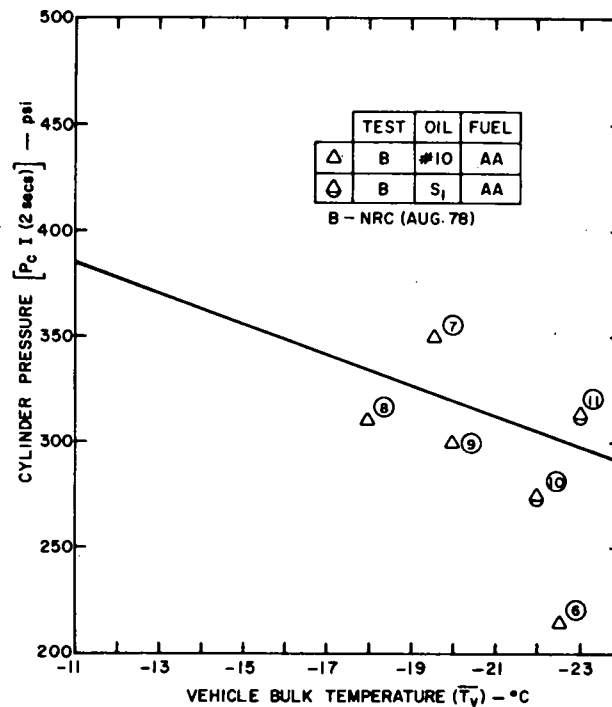

Fig. 23: Relationship between cylinder pressure 2 seconds after cranking was initiated and vehicle bulk temperature

The value shown for test 7 in Figure 23 in conjunction with an acceptable value of initial rpm in Figure 24 tends to indicate that decreased engine opposition and increased battery energy was present for this test. Reference to Table 1 indicates the engine oil temperature was, $T_{EO} = -14^{\circ}\text{C}$, the ambient temperature, $T_A = -14^{\circ}\text{C}$, was not depressed sufficiently before the cranking attempt, and the battery temperature was, $T_{BA} = -9^{\circ}\text{C}$. This indicates the above suspicion that there was less opposition by the engine due to the moderate sump temperature. Cylinder pressure was higher due to a higher ambient temperature and there was more energy available from the battery due to a higher battery temperature.

Figure 24 clearly shows the effect of lower oil viscosity for the synthetic oil increasing the initial cranking rpm. It should be noted that further testing should be done to indicate the true shape of these curves. The salient observation regarding the effects of oil viscosity though would be unchanged.

Throughout the testing the "Mini Starting Test Package" performed up to expectations. Its use with a strip chart recorder was straight forward. The only observed difficulties were as a result of human errors in not mounting the velocity sensors rigidly or at the correct .050 to .100 inch gap.

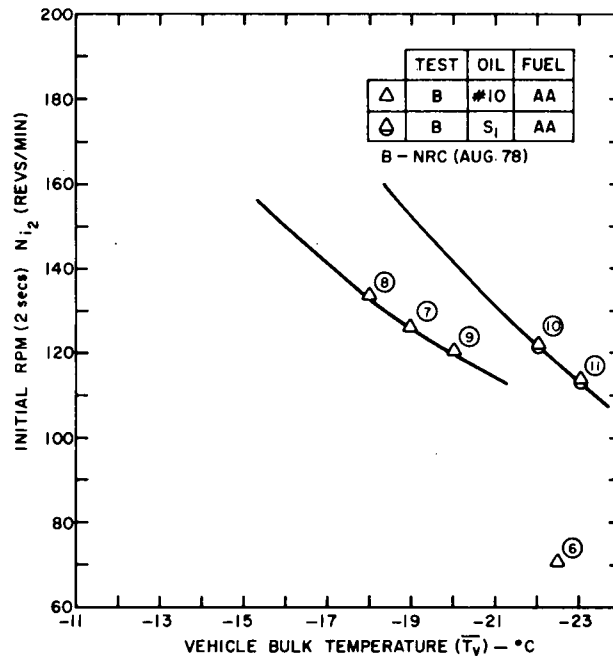

Fig. 24: Relationship between initial rpm at 2 secs after cranking was initiated and vehicle bulk temperature

CONCLUSIONS, RECOMMENDATIONS AND DISCUSSION

The conclusions and recommendations are treated in the same order of presentation as the study objectives.

Conclusion #1

The "No-Start Temperature $-T_{NS}$ ", using #10 oil and type AA fuel for the tests of this study was $T_{NS} \approx -20^{\circ}\text{C}$ (this was indicated by test #9, August 79, Figure 18 and 19).

The T_{NS} for the Arctic Grade synthetic oil DN600 and type AA fuel was $T_{NS} \approx -22^{\circ}\text{C}$ (this was indicated by test #10 and 11, Aug. 79, Fig. 18 and 19).

Recommendation #1(a)

It is recommended that further investigation of improvements to the air pre-heat system be conducted for temperatures lower than the -20°C .

It is recommended that further investigation of cranking speed, volatility and cetane number be conducted for temperatures lower than -20°C .

It is suggested that the fuel for these tests was slightly contaminated with condensed water vapour that may have affected combustion conditions such that the full starting capability of the fuel and engine system was not permitted. The fuel was not contaminated to the degree indicated by the fuel analysis of Appendix IX. It is believed that the contamination that existed for the December tests (22), Appendix XI occurred due to a low tank level during outside storage between September and December 1978. This accounts for the decreased starting capability for the December tests as evidenced by Figures 18 and 19.

Recommendation #1(b)

It is suspected that the moisture accumulation in the fuel for the August tests occurred during two periods when the cold chambers were brought up to ambient temperatures (on both of these days humid conditions existed). It is recommended that a brief low temperature study of injection penetration, spray patterns and other relevant parameters be conducted. Such a study could utilize an injector test stand for Type AA fuels with varying amounts of condensed water present. Injector test stands are presently available within the Department of National Defence supply system.

Conclusion #2

Qualitatively the August tests reconfirmed the Alert conclusions that the pressure trace is a useful means of identifying the combustion chamber phenomena moving through the 3 phases of combustion.

Recommendation #2

Quantitative data is still unreliable due to a static charge build up on the pressure transducer. The cylinder head was removed in May 1978 for inspection of the pressure transducer. At this time its isolation characteristics from the electrical ground appeared to be consistent with the transducer specifications. The transducer worked well during pre-cold chamber tests. However, this was not the case during both the June and August tests where a static charge build up gave inconsistent readings. It is recommended that this problem be solved to provide improved quantitative data for combustion phase analysis.

Conclusion #3

The voltage line method used in conjunction with the analog rpm was judged to be the most convenient method of consistently identifying the earliest time for which the engine was able to function unassisted by the starter motor.

Recommendation #3

When quantitative data with the pressure transducer is realizable

further quantitative analysis of the cylinder pressure combustion phase may lead to an improved method of identifying the time for which the engine has the ability to operate unassisted. It is recommended that this possibility be investigated further.

Conclusion #4

The "Mini Starting Test Package" that was tested further in this study has been found to be capable, inexpensive means of monitoring cold starting capability of Canadian Forces vehicles (Figure 1-V).

It is recommended that a brief manual be written explaining to possible CF users the practical procedures essential to obtain quantitative results with the "package".

Conclusion #5

It is concluded that improved battery insulation is essential for arctic winter operation.

Recommendations #5

With the 37mm of medium density polystyrene foam for battery compartment insulation used for these tests, 7.0 hours of (12 volt) 80 watt resistive wire heating were required to maintain the battery temperature at -15°C for an ambient temperature of -25°C for a 24 hour period (test #10). It is believed that further improvements to the insulation and its density within the battery compartment confines could reduce the heating time by one half, or 280 watt hours for a 24 hour period. These figures do not take into account battery temperature increases due to starting. The above numbers reflect the amount of heat required to keep the batteries at a temperature where they can provide the energy required for starting with low viscosity oil and accept a charge from the alternator following engine start up.

It is recommended that this work be extended to determine heating input quantities necessary to maintain battery temperature above -15°C for ambient temperatures down to -54°C . Examination of the thermal insulative resistances and types of insulation should also be included in the study. Such a study should also investigate the need and methods to remove combustible gases confined to the enclosed insulated battery box.

Conclusion #6

The air box heating system in conjunction with a particular starting procedure and use of the arctic clutch has been shown (for the August tests using type AA fuel) to be an effective means of air pre-heating down to -20°C with #10 oil and -22°C with DN600. The US tests (20) indicated the air box preheat system effective to -24°C with #10 oil and -33°C using a synthetic oil and fuel similar to type AA.

Recommendation #6

For the US tests cranking was initiated without fuel to combustion chambers for approximately 4 seconds. This is the same starting procedure used in the Alert tests (CSP) that was found to be inferior to cranking with fuel (NSP). It is recommended that more testing be carried out to determine the effects of each starting procedure while using the air box preheat system.

Conclusion #7

The cooling rates of the large cold chamber at the National Research Council behave in a similar fashion to ambient cooling rates in the Arctic for winds not exceeding 24 kph. This was determined by comparing cooling curves of the Alert tests with the June and August tests for this study.

GENERAL DISCUSSION AND RELATED RECOMMENDATIONS

The DREO study of low temperature starting for CF Tactical Land Vehicles indicated that starting difficulties below -25°C for compression ignition engines do exist and require additional study. It has been shown that battery heating is essential. Existing insulation, heating, charging and venting of battery systems for Arctic use, require considerable improvement. Two other (non-detectable) methods to maintain battery heat and charge for long periods of time at low temperatures are:

1. Use of thermoelectric remote power system to provide battery charging and utilize waste heat to maintain a constant battery temperature in an insulated compartment.
2. Use of a small 500 watt Stirling engine's remote power system to provide battery charging and utilize waste heat to maintain battery heat in an insulated compartment.

The present system of battery heating is via engine coolant heater. This system has been judged as a cumbersome and inadequate means of heating when used in conjunction with engine coolant heating. The system also does not provide a battery charging capability. Additionally the heat transfer rate away from a vehicle at low temperature indicates that engine coolant heating can work for only a short period of time after engine shut down.

Both methods would combust vehicle on board diesel fuel and incorporate a microprocessor control system for temperature sensing, charging, and combustor ignition.

Either of the above methods would maintain the battery energy state for long periods of time at depressed Arctic temperatures (-54°C) using only a small quantity of the vehicle's on board diesel fuel. However, this study indicated that, even with full battery capacity, Arctic grade diesel fuel and synthetic engine lubricating oil, battery cranking speeds were not sufficiently high enough to allow starting to occur for temperatures below -25°C . Four

possible solutions that have low level noise and heat signatures are presented; these solutions are judged superior* over existing and other methods:

1. Utilization of waste heat from a small (\approx 500 watt) thermoelectric remote power system to maintain a high engine oil temperature.
2. Utilization of waste heat from a small (\approx 500 watt) Stirling engine remote power system to maintain a high engine oil temperature.
3. Utilization of waste heat from a somewhat larger (\approx 2000 watt) Stirling engine power system to preheat the engine compartment and engine through engine coolant heating prior to engine cranking.
4. With the use of an on board micro processor system a vehicle would start and stop itself every few hours. This method could utilize existing battery heating (engine coolant) or resistive heating.

The first two proposals could be incorporated with either of the suggested battery heating methods, whereas, incorporation of solution 3 would be more difficult due to the larger 2000 watt engine. The engine oil would be drawn off the engine to the insulated battery compartment at shutdown. Before start up the hot oil would be pumped (auxillary pump) back through the engine on the high pressure side of the engine's oil pump. This would add heat to those areas that oppose cranking. Cranking would commence once a suitable oil sump level, temperature and battery capacity was achieved. This type of "Oil Transfusion"** does not appear to be documented in the literature and requires testing to determine its feasibility.

Due to the larger power requirements solution 3 would require a more advanced Stirling engine to perform the coolant heating than the air medium engines that could be used for solution 2.

The engine auto start and stop concept for solution 4 would use the vehicles alternator to provide battery charging and heating if the coolant heating was not used.

To briefly describe and to some degree quantify the advantages and disadvantages of each solution, Table 3 has been compiled (p. 45). Each area has been estimated to determine which solution is best \rightarrow 4 to worst \rightarrow 1. It is left up to the reader to place further weighting for priority areas. Without weighting the four solutions are relatively close in their totals.

* The degree of superiority has yet to be quantified.

** Oil Transfusion may present a solution to air cooled diesel engine cold starting difficulties, as the air-cooled engines do not have coolant water to preheat.

They are deemed to be close enough that each should be given further consideration. It is also foreseen that perhaps a combination of the first three solutions may be a plausible answer to the cold starting problem.

It is thus recommended that further study of these four solutions should be undertaken. It is believed that one or a combination of these solutions will greatly improve DND low temperature starting capability of its compression ignition tactical vehicle engine systems.

REFERENCES

1. Ricardo, H.R., Diesel Engines, Journal of the Royal Society of Arts, Vol. LXXX, 22 Jan. 1932.

NOTE - A recent discussion of the Ricardo combustion phases can be found in:

Taylor, C.F., The Internal Combustion Engine Theory and Practice, Vol. I & II, M.I.T. Press, 2nd Edition 1966, Vol. II, pp. 86-118.
2. Porter, H.R., Cold Starting Tests on Diesel Engines, Society of Automotive Engineers, Inc., Vol. 51, 1953.
3. Goodale, W.R., Low Pour Point Called Chief Need of "Low Temperature" Diesel Fuel, California Research Corp., May 1945.
4. Gruse, W.A., Motor Fuels - Performance and Testing, Reinhold Publishing Corp., New York, 1967.
5. Feldman, N., Operability of Automotive Diesel Equipment at Temperatures Below Fuel Cloud Point, Society of Automotive Engineers Meeting, Chicago Illinois, June 18, 1973, 730677.
6. Shoemaker, F.G., Gadenbusch, H.M., Effect of Fuel Properties on Diesel-Engine Performance, Society of Automotive Engineers, Inc., Vol. 54, 1946.
7. Germundson, O.M., Installation of Optional Equipment for Cold Weather Starting in Emergency Conditions, Society of Automotive Engineers, Chicago Illinois, June 17, 1974, 740547.
8. Kilty, D.E., Lammers, N.K., Fleck, K.J., Starting Cold Diesels, S.A.C., Vol. 61, Issue 2, pp. 36-40, Feb. 1953.
9. Bugelski, W.G., Preparation and Operation of Diesel Engines in Construction and Industrial Machinery for Operation in Cold Climates, S.A.E., Detroit Mich., Feb. 24-28, 1975, 740473.
10. Shaw, R., Starting Engines in -65°F Temperatures, Climate Unit, U.S. Army Ordnance, Tank Automotive Command, Vol. 68, Issue 12, pp. 127-128, Dec. 1960.

11. Heldt, P.M., Cold Starting for Diesel Engines Parts I & II, Automotive and Aviation Industries, Vol. 88, pp. 30-32, May, 1943.
12. Cloud, E.H., Ferenezi, L.M., Special Cold Starting Fuels for Diesel Engines, S.A.E. Journal, Vol. 52, No. 6, June 1944.
13. Atwell, L.P., Brumback, N.P., and Manthey, W.R., Cold Starting Diesel Engines with Low Voltage Ignition, S.A.E. Inc., April 5-6, 1960.
14. Blose, J.F., Factors Affecting Diesel Engine Starting, S.A.E. Journal, pp. 40-44, April 1952.
15. Knudsen, H.L., Cranking Power and Torque Requirements at Sub-Zero Temperatures, S.A.E., Vol. 51, pp. 280-284, August 1943.
16. Raines, A., Designing for Extreme Cold, Machine Design, pp. 103-106, May 1947.
17. Bowhay, E.J., Koenig, E.F., Factors Affecting Low Temperature Engine, S.A.E., Vol. 2, No. 1, Jan. 1948.
18. Austen, A.E.W., Lyn, N.T., Some Investigations on Cold Starting Phenomena in Diesel Engines, Professional Institute of Mechanical Engineers, No. 5, 1959-1960.
19. Webster, G.D., Hutton, G.J., Ferguson, W.A., and Glass, R., Arctic Low Temperature Starting Tests for the Compression Ignition Engine and System of the Canadian Forces Armoured Personnel Carrier (APC) M113A1, DREO Technical Note 78-23, Dec.
20. Webster, G.D., Glass, R.G., and Hutton, G.J., The Low Temperature Chamber Starting Tests for Candidate Vehicle Engine Systems of the Canadian Forces 2½ Ton Truck Replacement Programme, DREO Technical Note No. 80-22, Aug. 79.
21. Aberdeen Proving Ground, Maryland, Evaluation of Winterization Kit for the Carrier, Personnel, Full Tracked, Armoured M113A1, USA Reg. No. 12C588, Report #64-150 USATECOM Project No. 1-4-2620-05-D, 1964.
22. Brossard, L. and Gallop, L., The Behaviour of the Military Battery Type BB 248/U Used to Start the Engine of the A.P.C., Defence Research Establishment Ottawa, Technical Note No. 79-31, December 1979.
23. Cameron, G.L., Pettit, C.W. and Rowls, E.A., Cold Cranking Team: Battery Cables, Cranking Motor, Engine Oil, DELCO - Remy Div., General Motors Corp.

24. Canadian Department of Supply and Services, Specification Board, Standard for Diesel Fuel, 3-GP-6M, (The standard applies to five types of petroleum derived diesel fuel oil), December 1977.

ABBREVIATION LIST

ABH	- Air box heater
AC	- Arctic clutch
A/F	- Air fuel ratio
APC	- Armoured personnel carrier
a.t.c.	- At top centre
AVG	- Average
BH	- Battery heating
BI	- Battery insulation
°C	- Centigrade degrees
CF	- Canadian Forces
CFS	- Canadian Forces station
C.I.	- Compression ignition
CPS	- Cycles per second
CSP	- Canadian start procedure
CT	- Cranking time
CTS	- Cycles to start
E	- Voltage
E _{sp}	- Peat starter voltage
∞	- Infinity
I	- Current
NSP	- New start procedure
(\bar{N})	- Average RPM
NM	- Not marginal
NS	- No start
PBI	- Partial battery insulation
PBC	- Poor battery charge
P _c	- Cylinder pressure
PSI	- Pound per square inch
Q _A	- Air flow rate

ABBREVIATION LIST (Cont'd)

RPM	- Revolutions per minute
S	- Start
SECS	- Seconds
SI	- Spark ignition
T _A	- Ambient temperature
T _C	- Cloud point temperature
T _P	- Pour point temperature
TNS	- No start temperature
\bar{T}_V	- Bulk vehicle temperature
V	- Volt
V _w	- Wind velocity

FIGURE LIST

- Figure 1: Phases of Combustion.
- Figure 2: Instrumentation Vehicle Beside Cold Chamber at the National Research Council.
- Figure 3: Instrumentation Racks Inside Instrumentation Vehicle.
- Figure 4: Instrumentation Racks Inside Instrumentation Vehicle.
- Figure 5: Quick Connect-Disconnect Panel for Electrical Inputs Between the Cold Chamber and the Instrumentation Vehicle.
- Figure 6: Cooling Curves Test #1.
- Figure 7: Cooling Curves Test #2.
- Figure 8: Cooling Curves Test #3.
- Figure 9: Cooling Curves Test #4.
- Figure 10: Cooling Curves Test #5.
- Figure 11: Cooling Curves Test #6.
- Figure 12: Cooling Curves Test #7.
- Figure 13: Cooling Curves Test #8.
- Figure 14: Cooling Curves Test #9.
- Figure 15: Cooling Curves Test #10.
- Figure 16: Cooling Curves Test #11.
- Figure 17: Chart Recording for Test 7, Utilizing the Revised Voltage Line Method.
- Figure 18: Relationship Between Cycles to Start and Vehicle Bulk Temperature.
- Figure 19: Relationship Between Cranking Time and Vehicle Bulk Temperature.
- Figure 20: Relationship Between Average Cranking RPM and Vehicle Bulk Temperature.
- Figure 21: Relationship Between Peak Starter Voltage and Vehicle Bulk Temperature.
- Figure 22: Relationship Between Peak Starter Current and Vehicle Bulk Temperature.
- Figure 23: Relationship Between Cylinder Pressure 2 sec After Cranking was Initiated and Vehicle Bulk Temperature.
- Figure 24: Relationship Between Initial RPM and 2 sec After Cranking was Initiated and Vehicle Bulk Temperature.

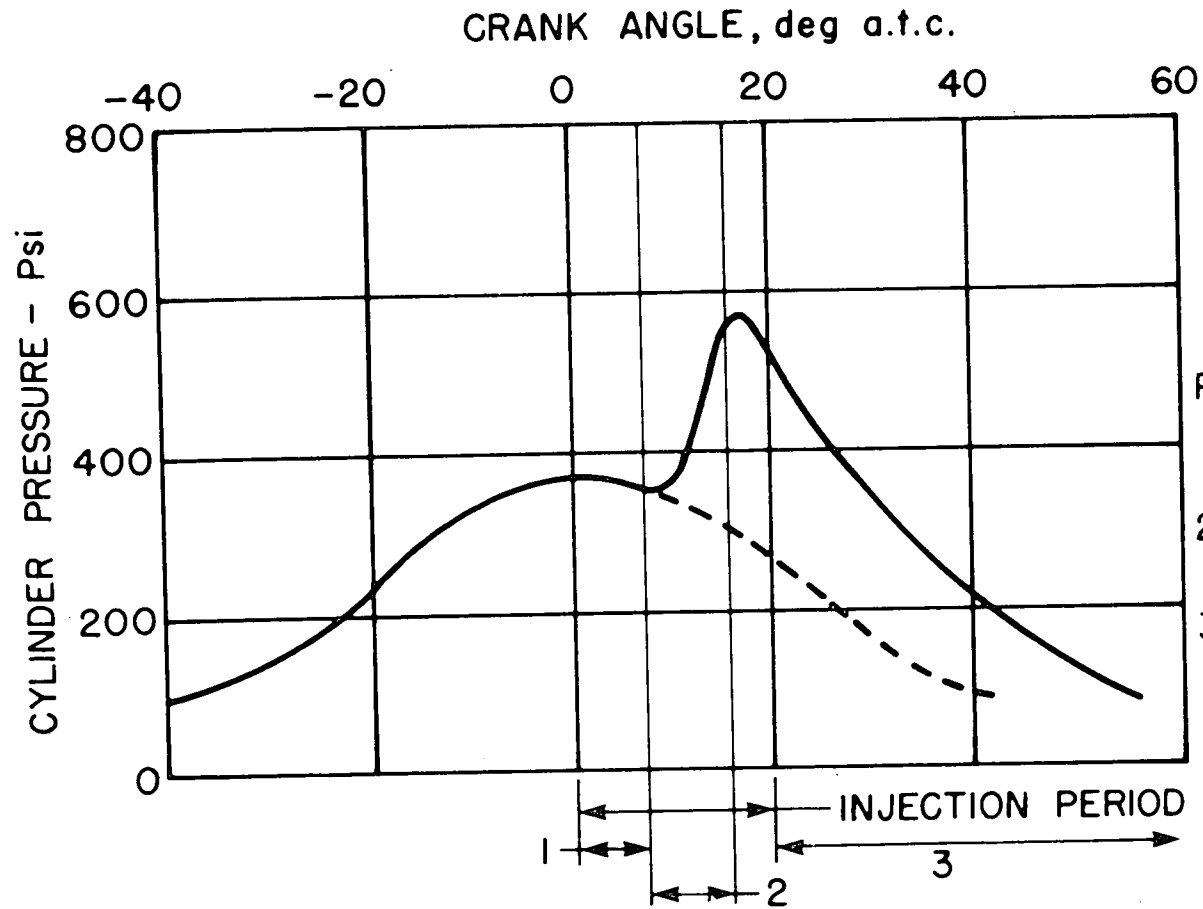

FIGURE 1
Phases of Combustion

- 1. Delay Period Phase
- 2. Rapid Combustion Phase
- 3. Completion of Combustion Phase

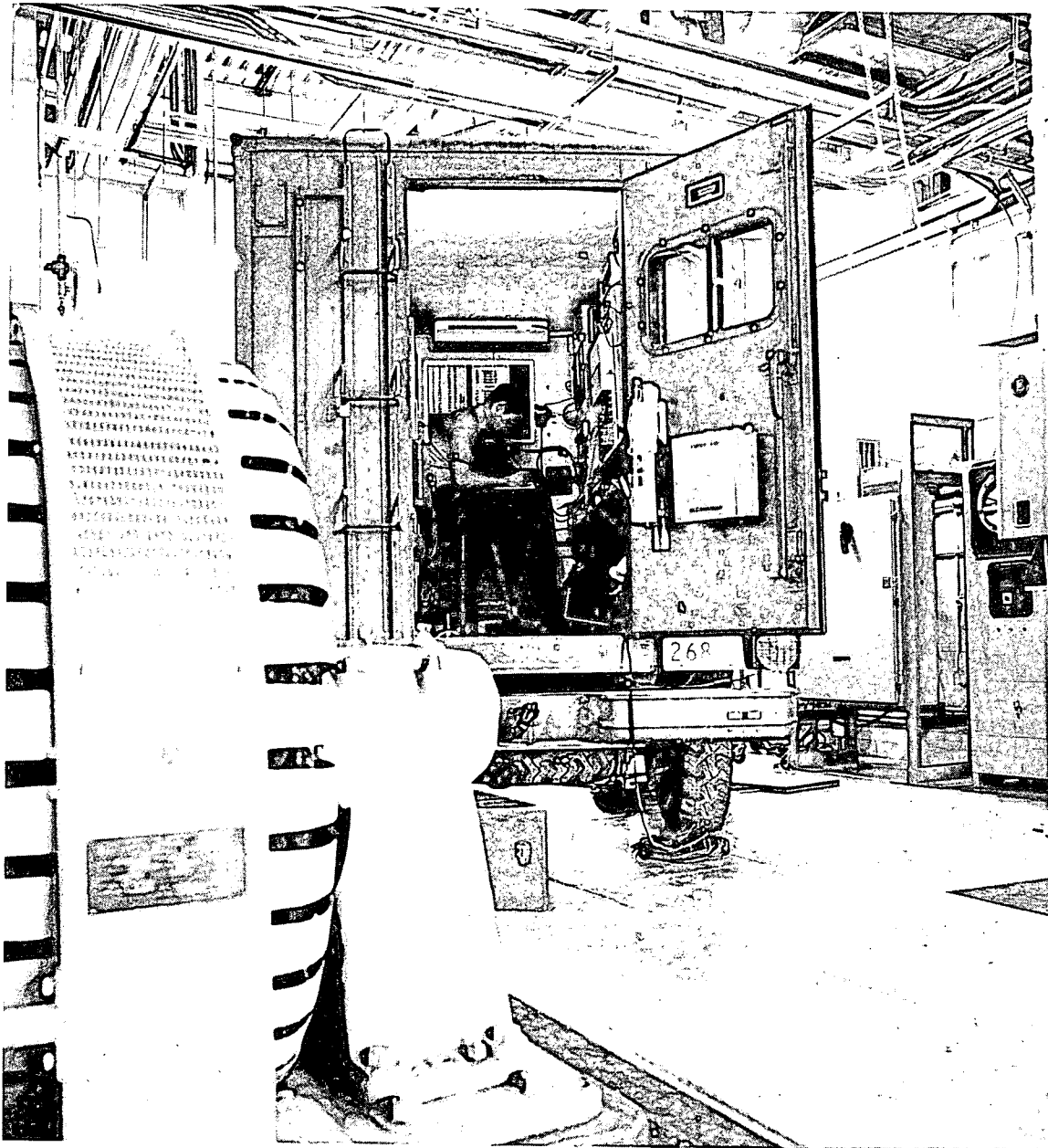

Fig. 2: Instrumentation Vehicle Beside Cold Chamber at the National Research Council.

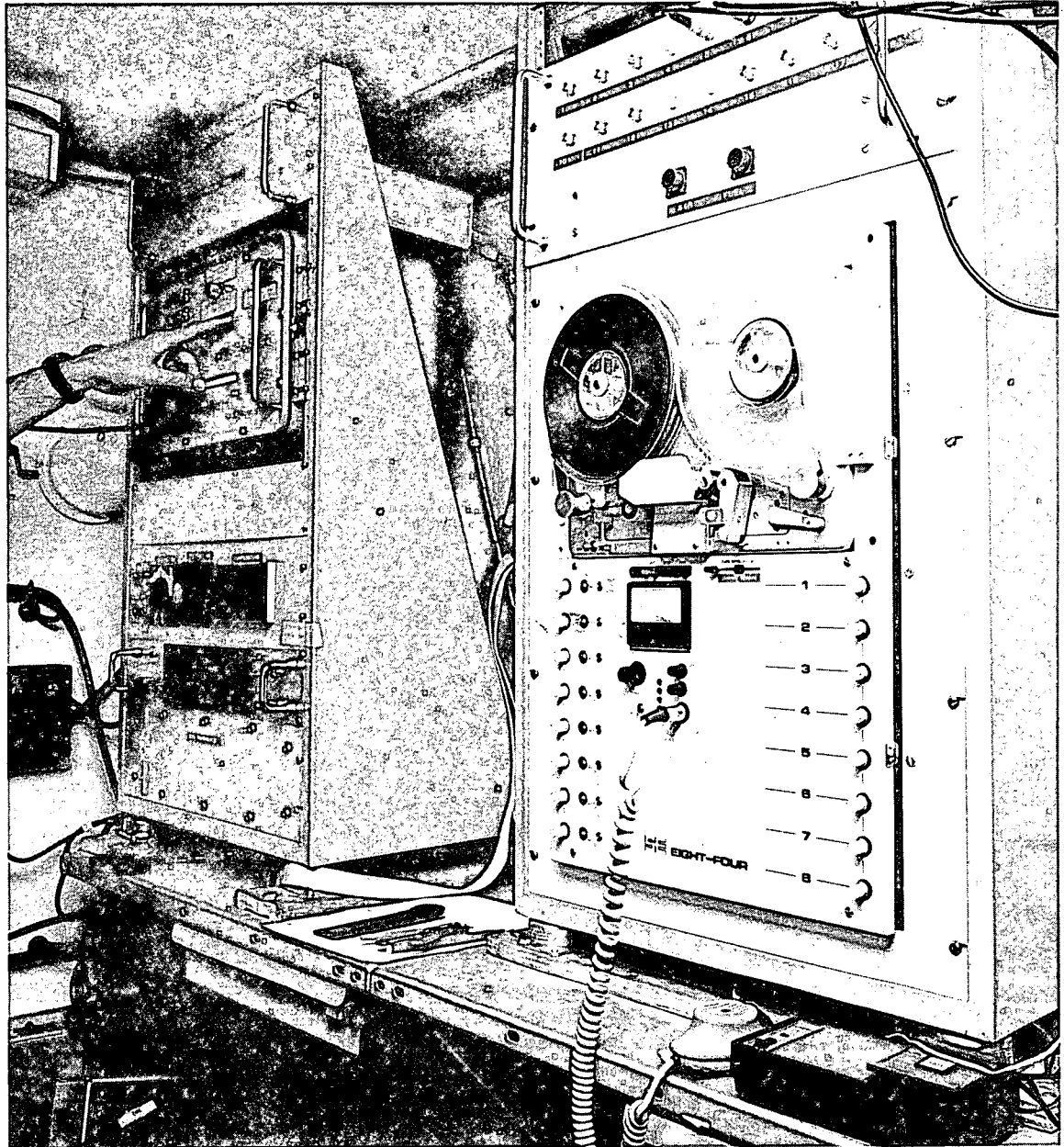

Fig. 3: Instrumentation Racks Inside Instrumentation Vehicle.

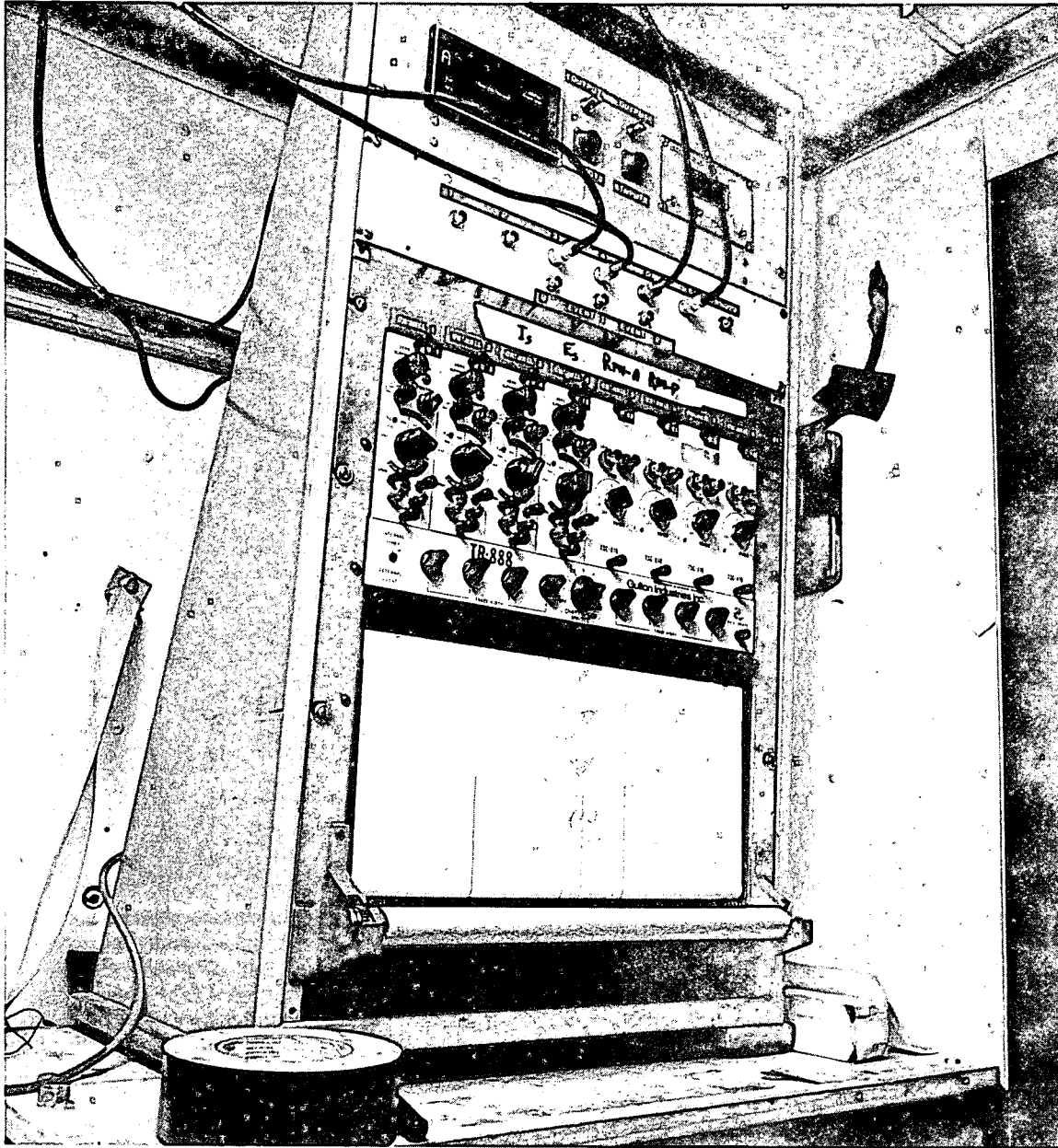

Fig. 4: Instrumentation Racks Inside Instrumentation Vehicle.

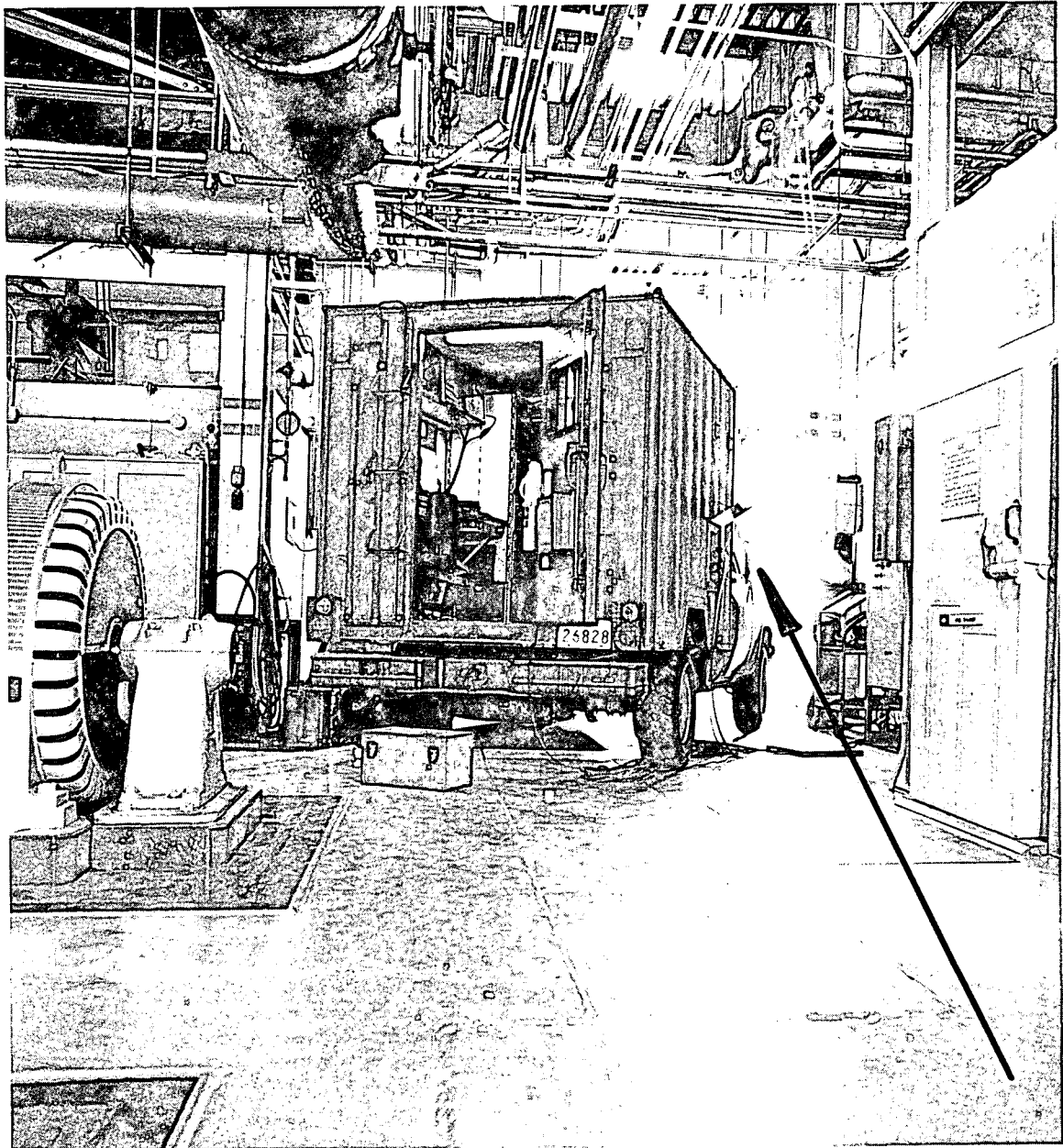

Fig. 5: Quick Connect-Disconnect Panel for Electrical Inputs Between the Cold Chamber and the Instrumentation Vehicle.

TABLE 1

Test No.	1-R1	2-R1	3-R1	4-R1	5-R1	6-R1	6-R2	7-R1	8-R1	9-R1	10-R1	11-R1
¹ Cold Soak Time (hrs)	34.8	11.48	15.83	20.38	42.17	19.6	.6	31.4	12.95	15.58	18.1	21.73
Start - S, No Start - NS	NS	NS	S	NS	S	NS	S	S	S	S	S	NS
² Ambient Temp. - T _A (°C)	-28	-16	+1.0	-28	-16	-20	+13	-14	-20	-24	-27	-27
³ Oil Sump Temp. - T _{EO} (°C) = \bar{T}_V	-20	-15	-4	-20	-15	-22	-16	-14	-18	-20	-22	-23
⁴ Battery Temp. - T _{BA} (°C)	-20.0	-10.3	-2.9	-15.5	-7.4	-22.0	-3.0	-9.0	-16.0	-15.0	-19.5	-14.5
⁵ Specific Gravity (Battery) - SG	1.270	1.275	1.235	1.255	1.270	1.255	-	1.250	1.255	1.250	1.255	1.250
Oil Type	#10	#10	#10	#10	#10	#10	#10	#10	#10	#10	S	S
Battery Heating - BH	-	-	-	-	-	-	-	-	-	BH	BH	BH
Arctic Clutch Disengaged - AC	AC	AC	AC	AC	AC	AC	AC	-	AC	AC	AC	AC
Throttle Position	100%	100%	0%	100%	100%	100%	100%	100%	100%	100%	100%	100%
No slave - NSL, Slave - SL	NSL	NSL	NSL	NSL	NSL	NSL	NSL	NSL	NSL	NSL	NSL	NSL
⁶ Airbox Heater Time - (Secs)	-	-	-	-	2.25	4.35	-	2.7	3.5	3.6	2.15	4.4
Starting Officer - A,B	A	A	A	A	B	B	B	B	B	B	B	B

1,2,3,4,5,6 - Before Cranking

4 - Was also Measured with a Calibrated Thermometer

UNCLASSIFIED

UNCLASSIFIED

TABLE 2

	1-R1	2-R1	3-R1	4-R1	5-R1	6-R1	6-R2	7-R1	8-R1	9-R1	10-R1	11-R1
Oil Sump Temp. - T_{EO} ($^{\circ}C$) = \bar{T}_v	-20	-15	-4	-20	-15	-22	-16	-14	-18	-20	-22	-23
Start - S, No Start - NS	NS	NS	S	NS	S	NS	S	S	S	S	S	NS
Cycles to Start - CTS (cycles)	>24	>64.8	5	>99.5	320	>105	4	120	86	110	180	>338.5
Cranking Time - CT (Sec)	62.7	36.1	1.13	78.9	95.1	95.4	0.75	50.05	29.9	39.2	71.55	155.
Avg. Cranking Speed - N (RPM)	23.9	107.6	265.2	75.6	202	66	320	144	149	168.4	151	131
Initial Cranking Speed - N_i (RPM)	24	115.4	162	69.7	85.7	70.5	200	126	133	121.2	122.4	114.3
Max. Cranking Speed - N_{MAX} (RPM)	24	115.8	428	157.9	800	70.5	400	400	666	500	480	600
Final Cranking Speed - N_f (RPM)	23	--	--	57.6	800	50	500	410	500	300	428.6	104.3
Initial Cyl. Pressure - P_i x 250psi	--	--	1.4	0.8	1.2	0.85	4.6	1.4	1.3	1.2	1.1	1.25
Cyl. Pressure 6 secs - P_6 x 250psi	--	1.4	--	0.8	1.2	1.3	--	1.45	1.3	1.4	1.3	1.3
Final Cyl. Pressure - P_f x 250psi	--	--	--	--	--	--	--	--	--	--	--	--
Open Circuit Battery - E_{max} (Volts)	25	24.75	24.0	25.0	24.85	24.5	24.75	24.8	24.5	24.5	24.5	24.5
Peak Minimum Starter - E_{sp} (Volts)	12.50	14.25	13.5	14.5	13.50	12.5	14.0	14.0	14.25	13.5	13.9	13.5
Cranking Starter - E_s (Volts)	10.5	10.5	10.5	10.5	11.35	12.0	10.75	10.8	5.25	11.0	10.6	11.0
Peak Maximum Starter - I_{sp} (Amps)	516	696	636	684	636	618	612	624	636	660	636	636
Cranking Starter - E_{s2} (Volts)	12.85	14.0	--	12.0	15.0	13.5	--	16.5	16.5	16.0	16.5	16.0
Cranking Starter - I_{s2} (Amps)	408	408	--	480	420	432	--	312	324	336	336	366
Cr. Power - $(E_s I_s)_2 \times 10^3$ (Watts)	5.24	5.7	--	5.76	6.3	5.83	--	5.15	5.35	5.4	5.54	5.86
Peak Cr. Power - $(E_{sp} I_{sp}) \times 10^3$ (Watts)	6.48	9.92	6.68	7.18	8.6	7.7	8.6	8.7	12.2	8.9	8.8	8.8
Airflow Initial - $Q_{Ai} \times 100$ CFM	--	1.4	--	0.4	0.6	.55	--	.8	.85	.82	.85	.8
Airflow (6 sec) - $Q_{A6} \times 100$ CFM	--	.7	--	0.4	0.6	.5	--	.82	.85	.85	.90	.8
ABH before Cr.	--	--	--	--	2.25	4.35	--	2.7	3.5	3.6	2.15	4.4
ABH during Cr.	--	--	--	--	48	57.7	--	29.25	22.1	29.7	58.5	120.5
% ABH used in Cr. cycle	--	--	--	--	58.5	60.5	--	48.6	75.1	75.6	81.7	77.2

Subscript 2 - refers to 2 seconds after initial cranking.

- refers to a number of cycles in excess of what is shown before starting might occur.

UNCLASSIFIED

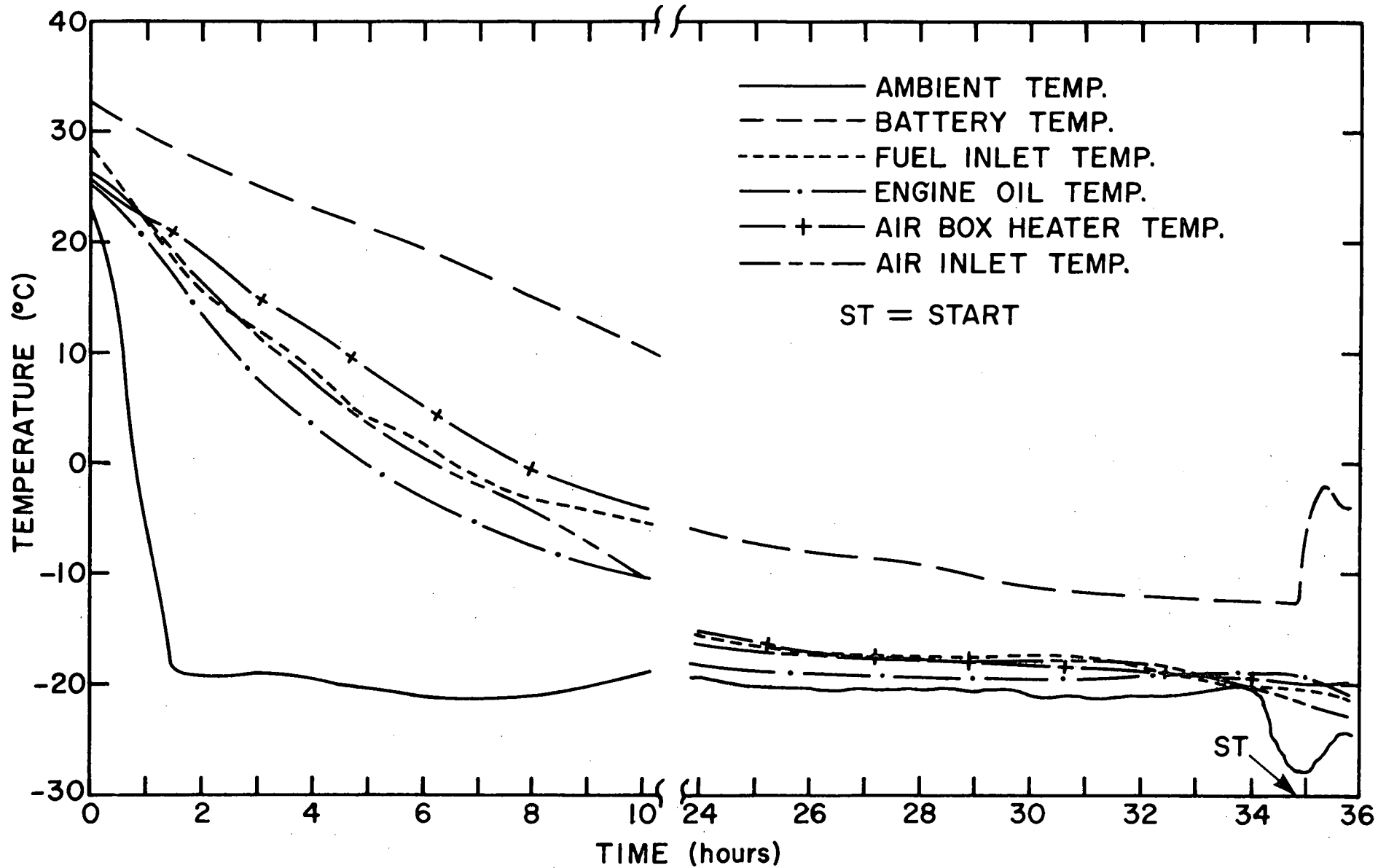

UNCLASSIFIED

Fig. 6: Cooling Curves Test #1.

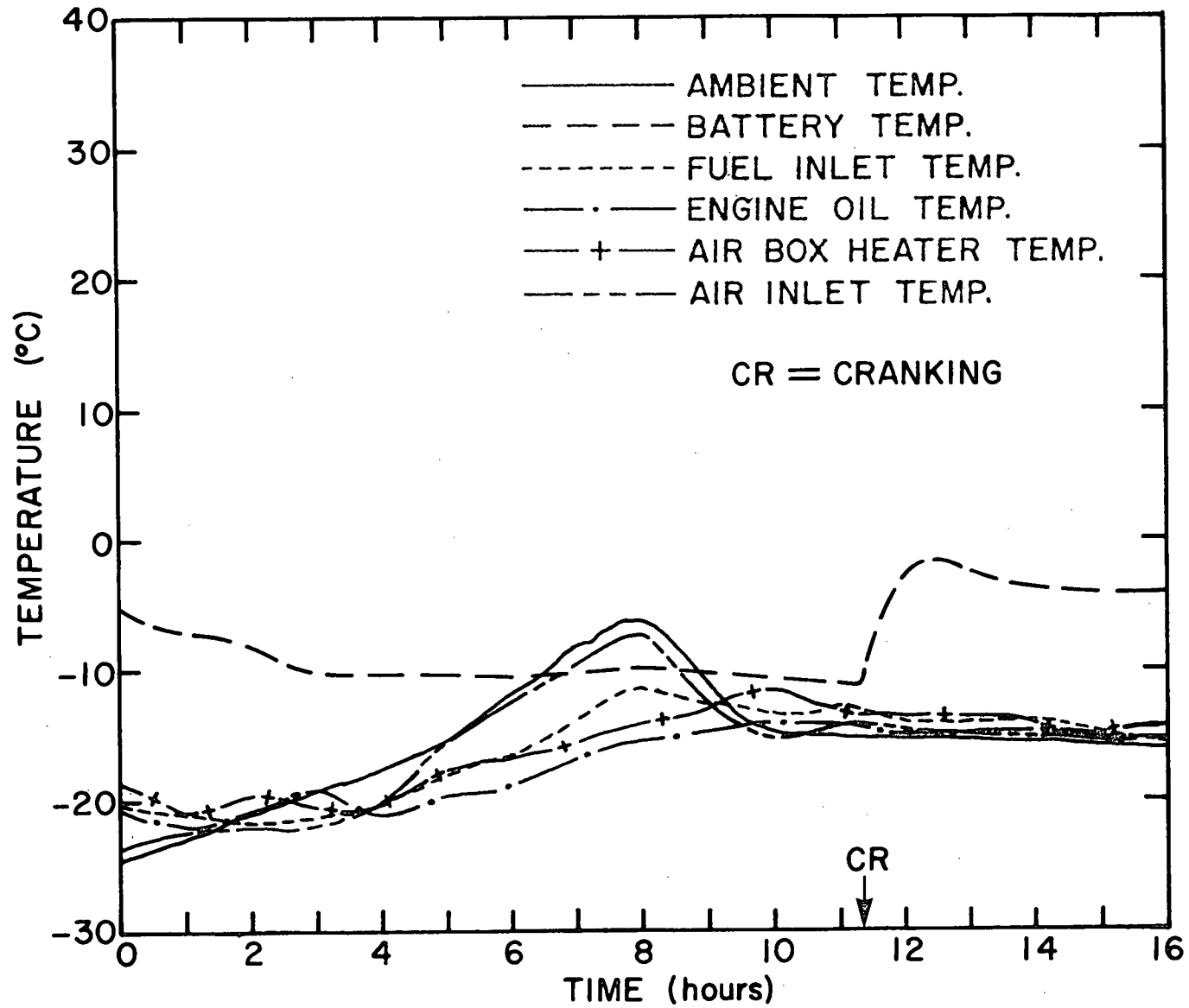

Fig. 7: Cooling Curves Test #2.

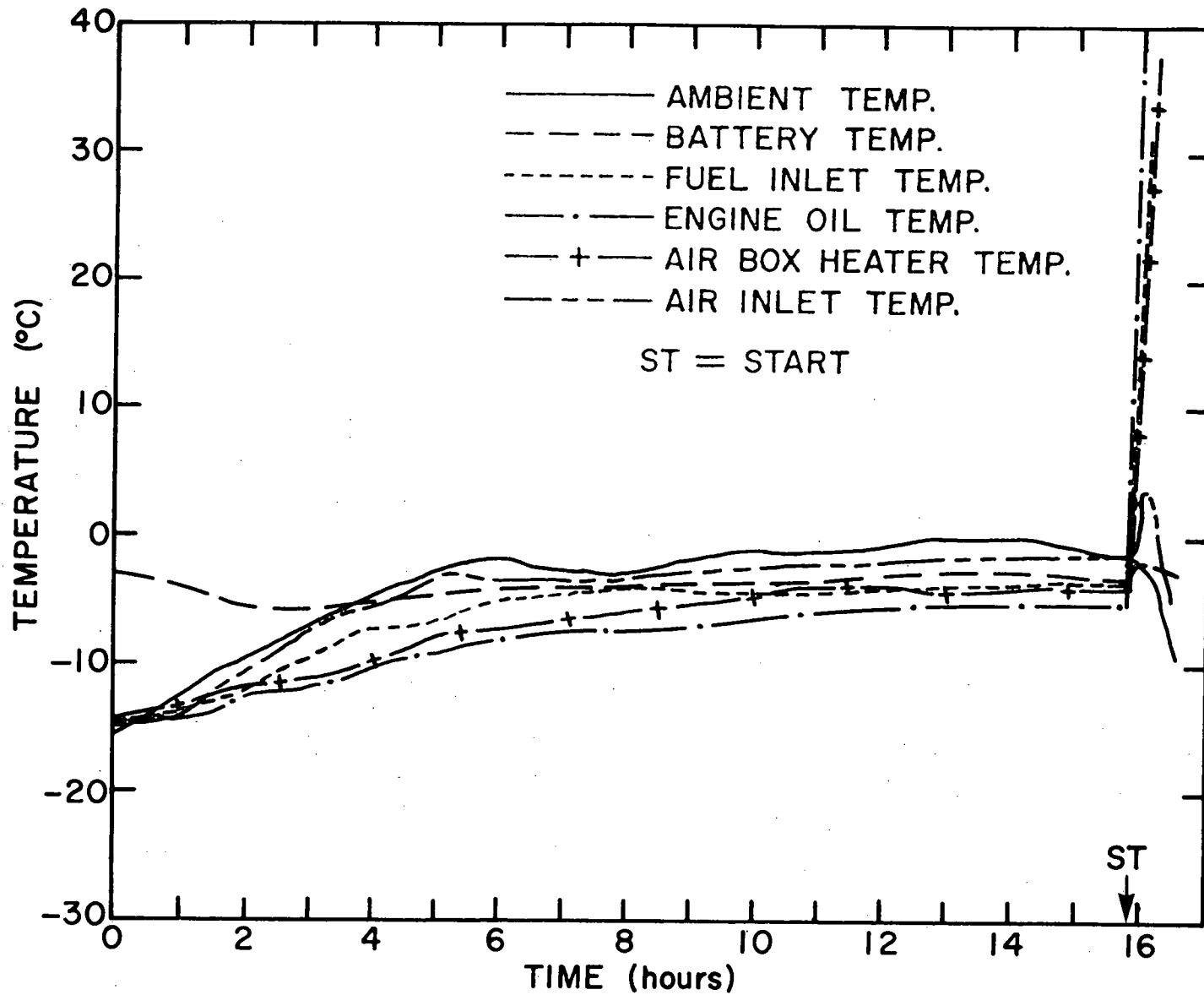
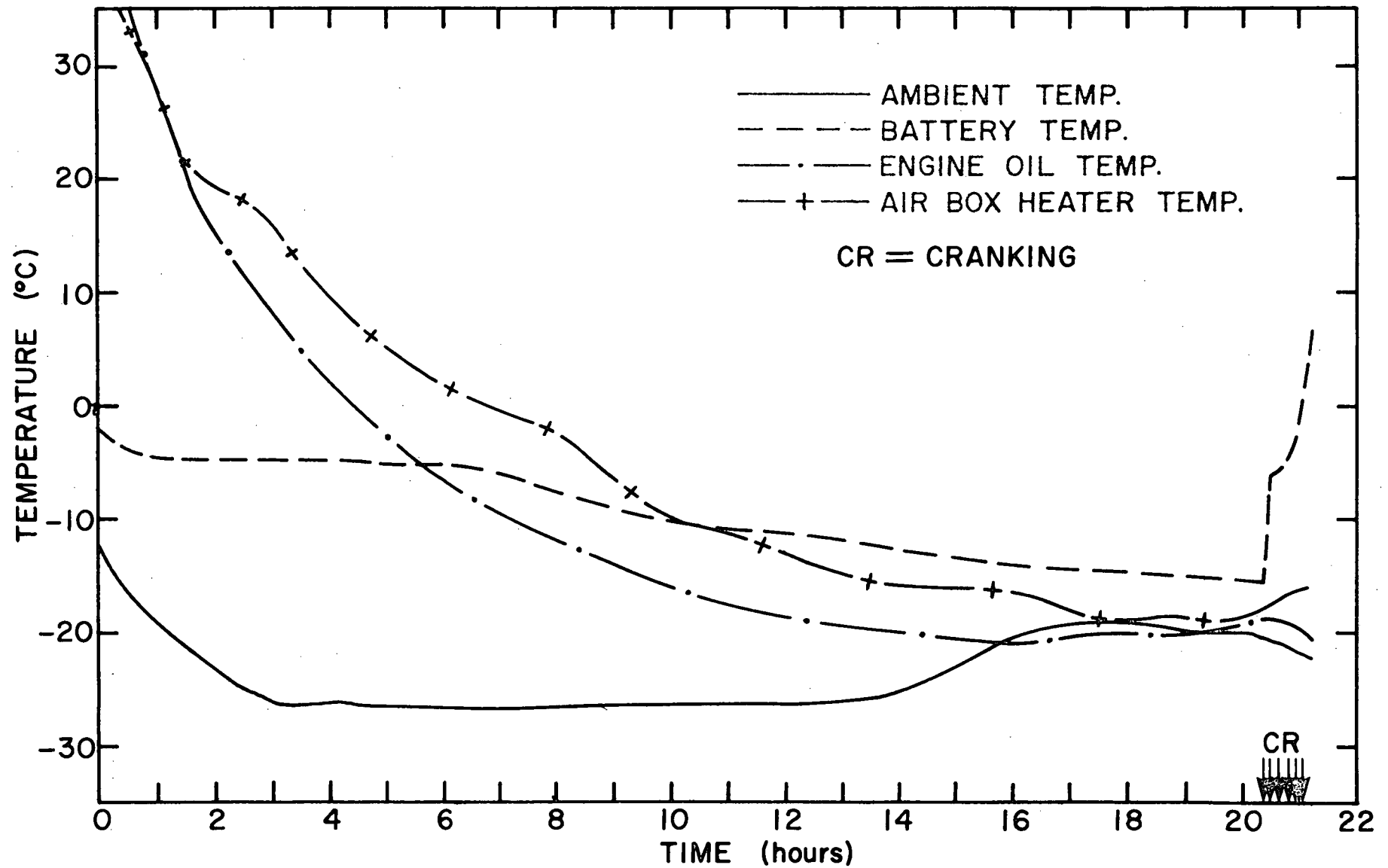

Fig. 8: Cooling Curves Test #3.

UNCLASSIFIED



UNCLASSIFIED

Fig. 9: Cooling Curves Test #4.

UNCLASSIFIED

UNCLASSIFIED

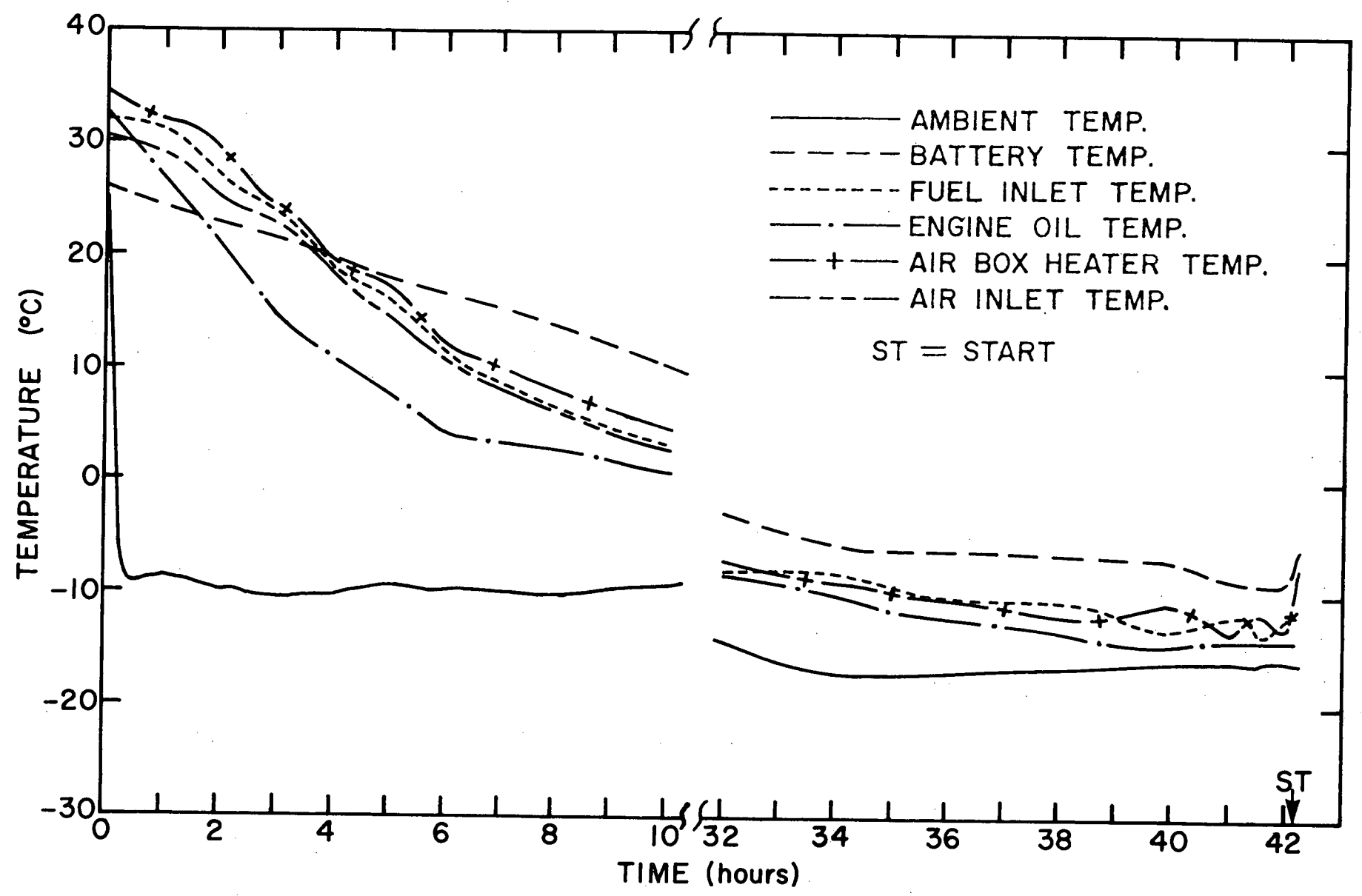
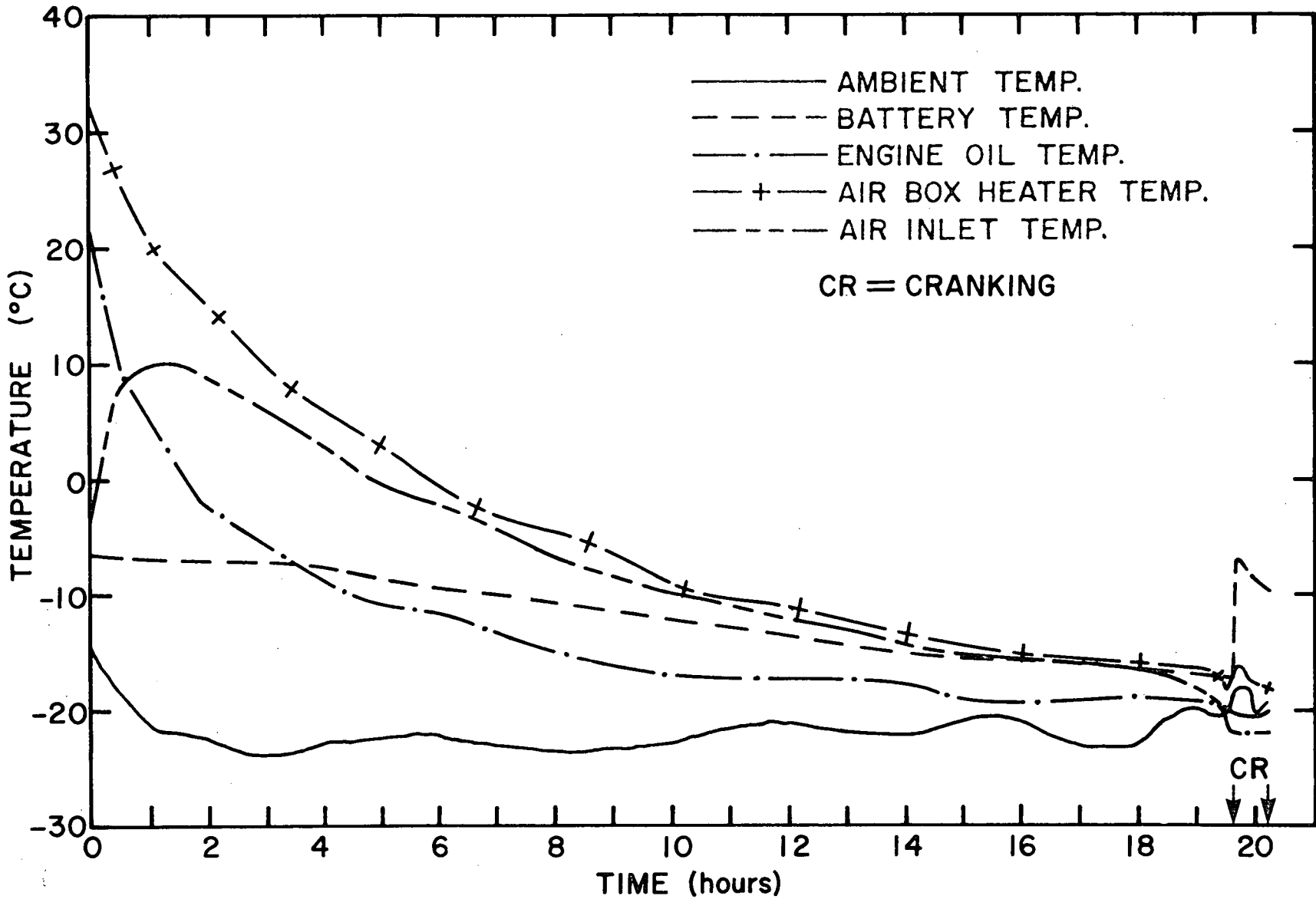

Fig. 10: Cooling Curves Test #5.

UNCLASSIFIED



UNCLASSIFIED

Fig. 11: Cooling Curves Test #6.

UNCLASSIFIED

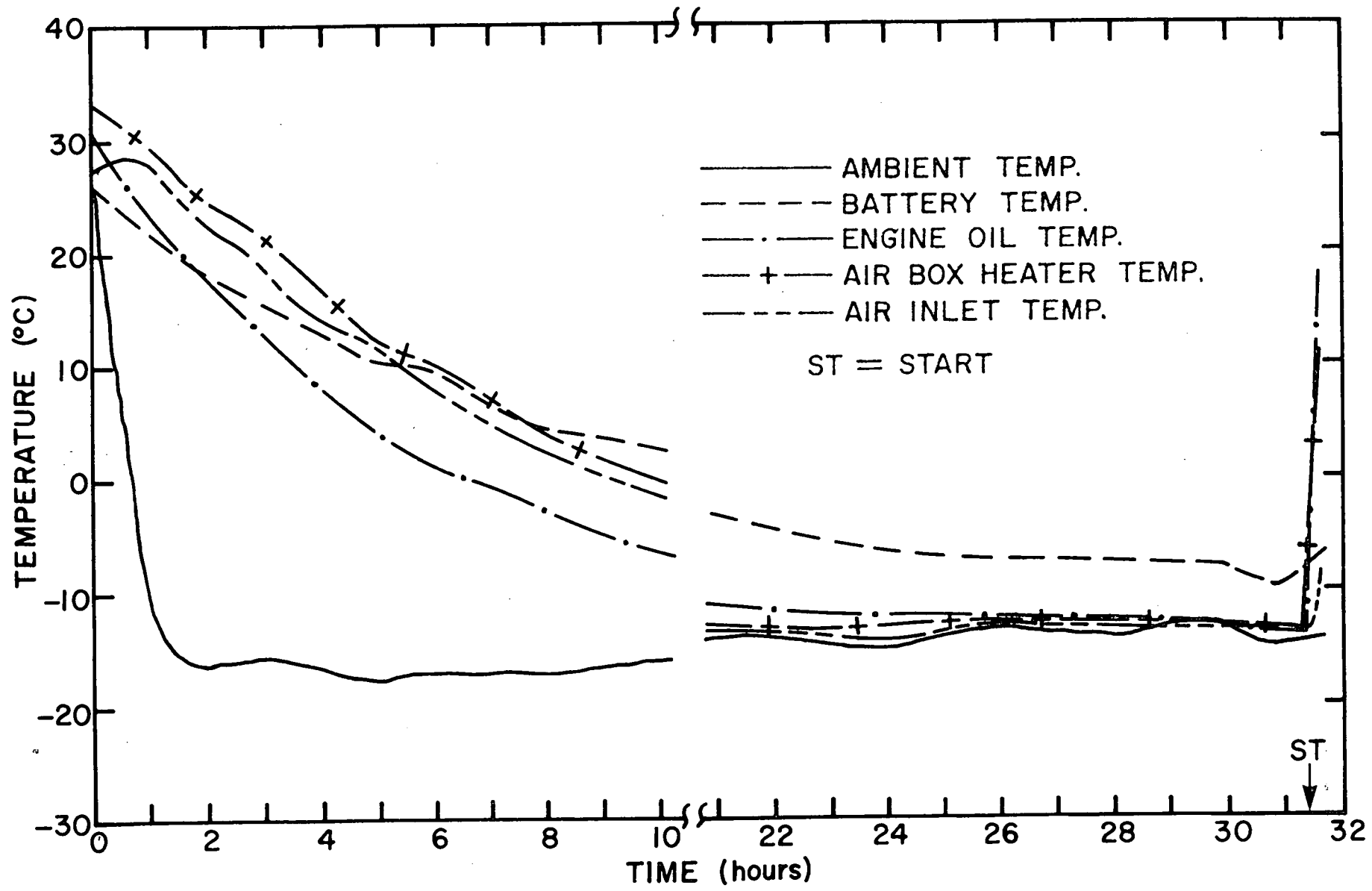

UNCLASSIFIED

Fig. 12: Cooling Curves Test #7.

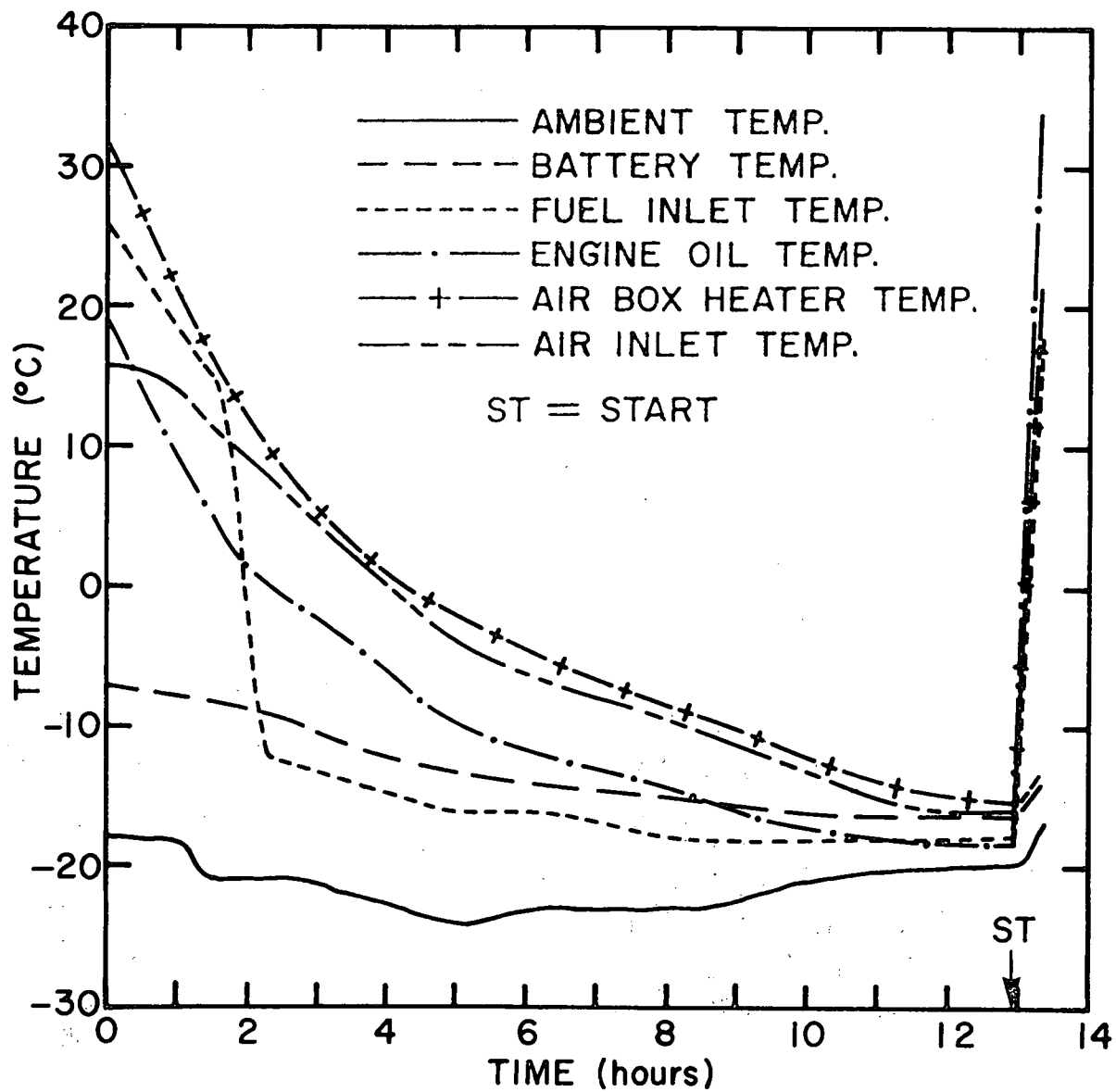

Fig. 13: Cooling Curves Test #8.

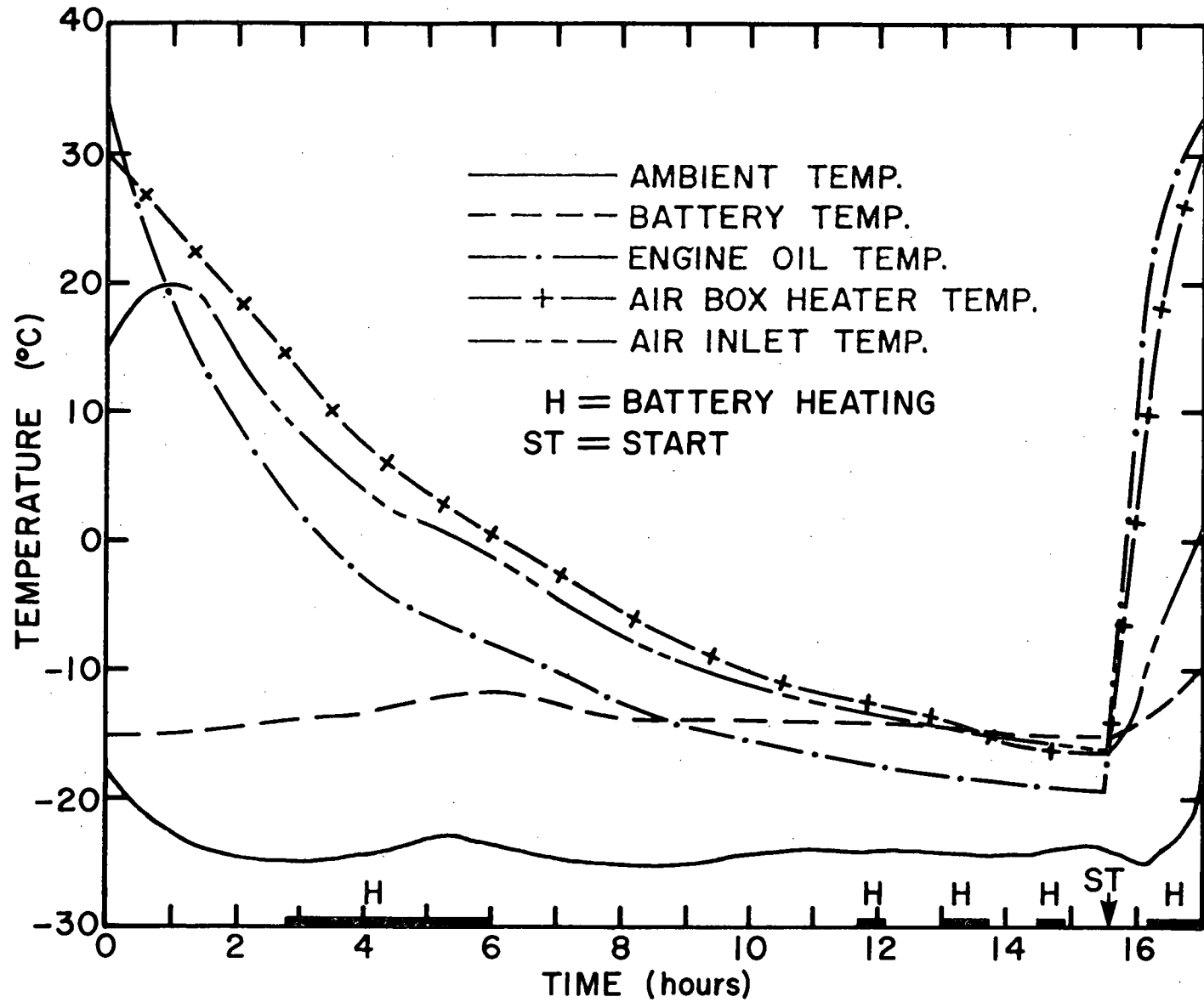
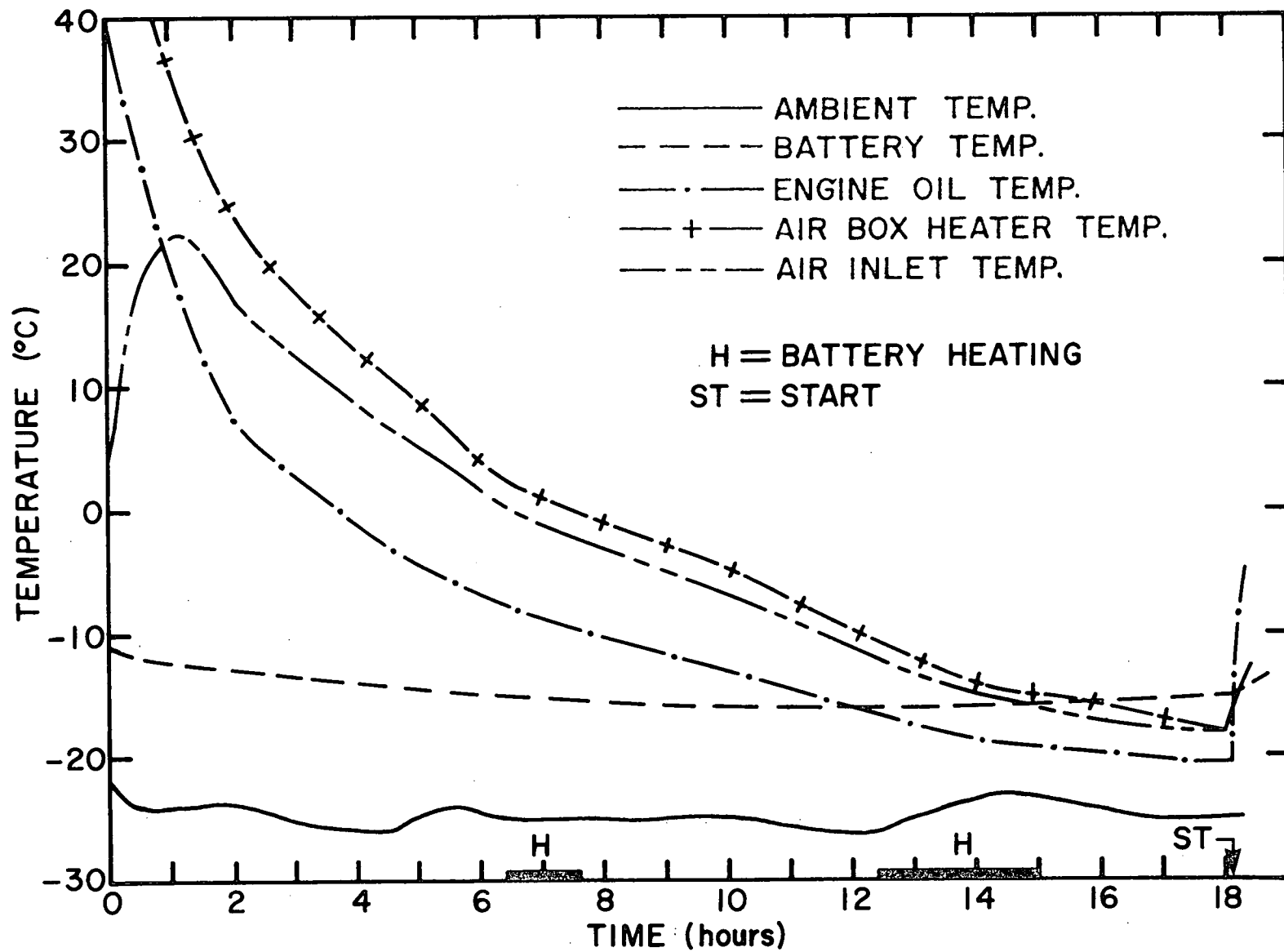

Fig. 14: Cooling Curves Test #9.

UNCLASSIFIED



UNCLASSIFIED

Fig. 15: Cooling Curves Test #10.

UNCLASSIFIED

UNCLASSIFIED

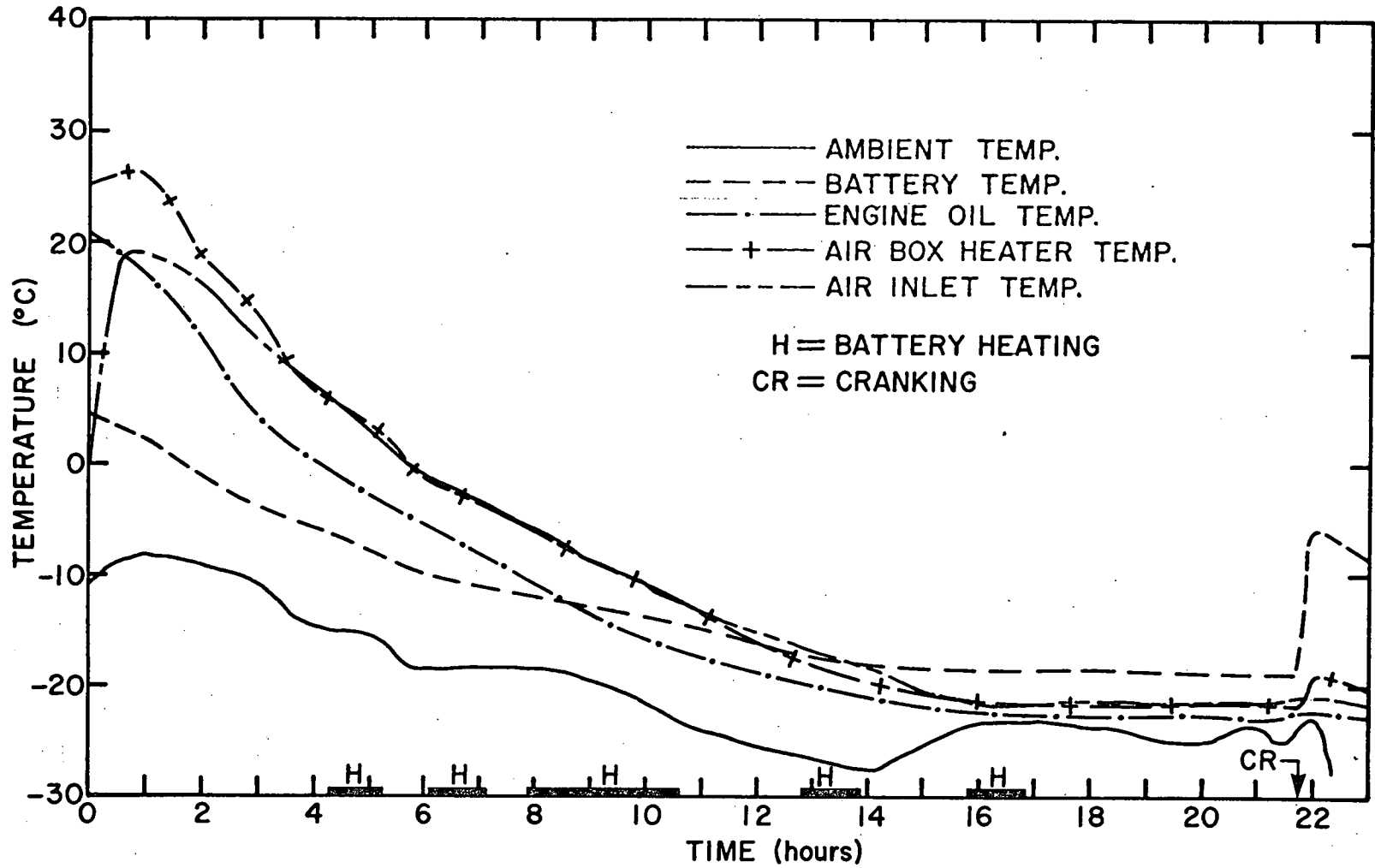

Fig. 16: Cooling Curves Test #11.

TABLE 3

An Unweighted Numerical Estimate of 4 Solutions
Advantages and Disadvantages

Descriptions of Advantages and Disadvantages as Seen to Affect the Four Solution Systems	Solution 1	Solution 2	Solution 3	Solution 4
Lowest Cost (Production & Installation)	2	2	3	4
Reliability	3	2	2	4
Ease of Maintenance	3	2	2	4
Non-Detectability	4	3	2	1
Lowest Fuel Consumption	3	4	2	1
Small Package Size	1	3	2	4
Lack of Deleterious Effects on Engine System	4	4	4	3
Shortest Time to Engine Start	3	4	2	4
Ability to go Unattended for Long Periods	4	3	3	2
TOTALS	27	27	22	27

UNCLASSIFIED

LIST OF APPENDICES

	<u>Page</u>
<u>APPENDIX I</u> : CETANE NUMBER	47
<u>APPENDIX II</u> : INSTRUMENTATION WIRING DIAGRAMS	48-61
<u>APPENDIX III</u> : ENGINE SPECIFICATIONS	62-64
<u>APPENDIX IV</u> : PHYSICAL MEASUREMENT LAYOUT	65-72
<u>APPENDIX V</u> : MINI-STARTING TEST PACKAGE	73-75
<u>APPENDIX VI</u> : DATA RECORDING AND PROCESSING	76-91
<u>APPENDIX VII</u> : BATTERY INSULATION AND HEATING	92-93
<u>APPENDIX VIII</u> : DISCUSSION OF VOLTAGE LINE METHOD FROM REFERENCE 18	94-96
<u>APPENDIX IX</u> : FUEL ANALYSIS	97-101
<u>APPENDIX X</u> : U.S. TESTS	102-103
<u>APPENDIX XI</u> : DECEMBER TESTS	104-105

UNCLASSIFIED

APPENDIX I

CETANE NUMBER

Cetane number is a means of rating diesel fuel ignition capability based on its delay period. The cetane rating or the ignition quality of diesel fuel is analogous to octane ratings of gasoline. The octane rating is based on knocking or detonation instead of delay period. A sample of fuel is tested on a standard test engine. Its delay period is measured. This value is then compared with the percentage blend of cetane ($C_{16}H_{34}$), a straight chain paraffin of excellent ignition quality, and alpha-methyl naphthalene ($C_{10}H_7CH_3$), a naphthenic compound having poor ignition quality that produces the same delay period. It was found (2) that if the cetane number was increased to improve the starting time, it also hampered the situation by increasing the temperature of wax crystal formation. Goodale (3) suggested starting with a small supply of heated high cetane fuel and switching to low cetane fuel once starting was achieved. It is noteworthy to mention that use of $C_{10}H_7CH_3$ was changed (4) in 1964 to heptamethyl nonane, a highly branched paraffin which has a cetane number of 15 instead of zero. The equation for cetane number is given as: $CN = \% \text{ cetane} + 0.15 (\% \text{ heptamethyl nonane})$.

UNCLASSIFIED

APPENDIX II

INSTRUMENTATION WIRING DIAGRAMS

UNCLASSIFIED

UNCLASSIFIED

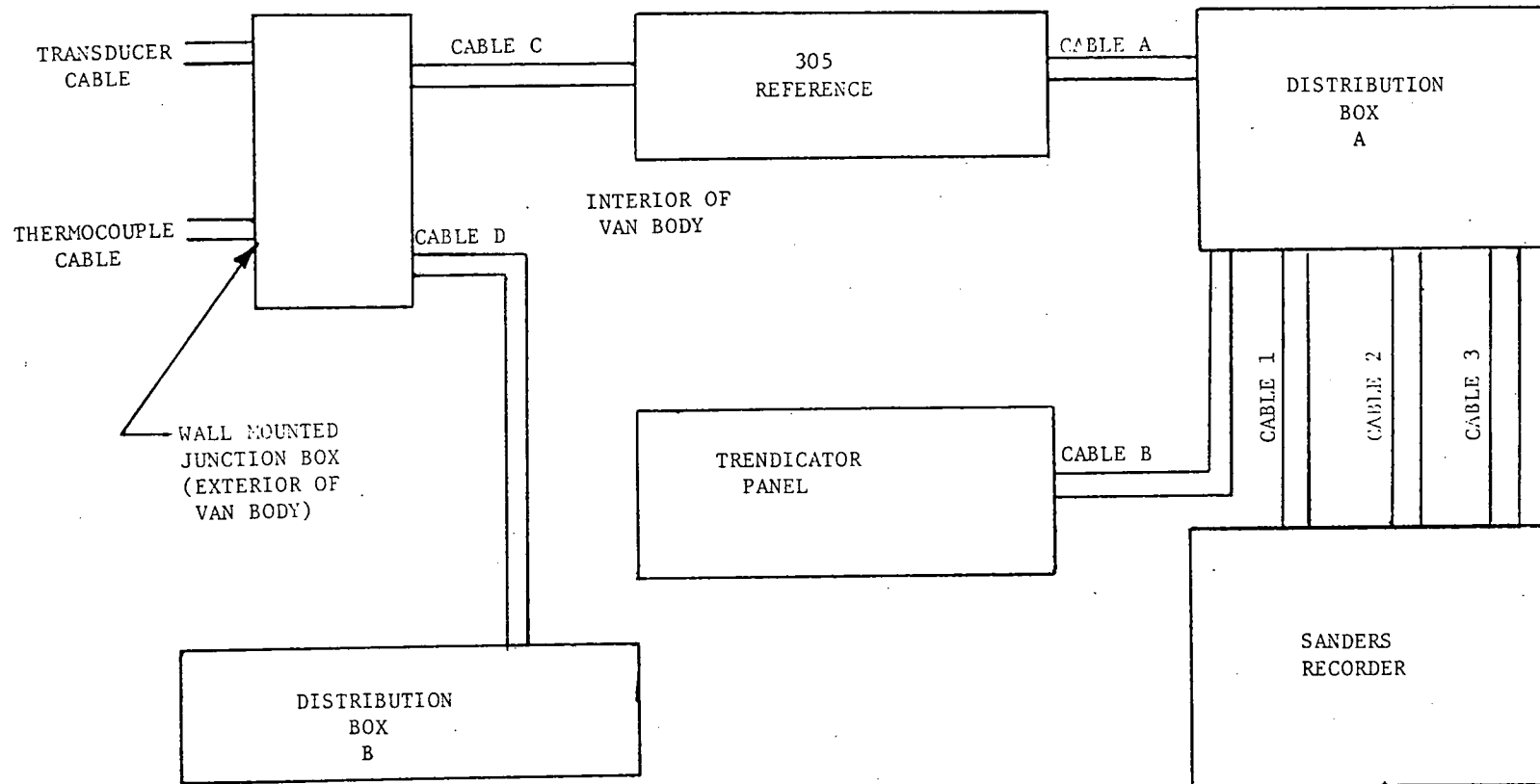

UNCLASSIFIED

Fig. 1-II: Electrical System Block Diagram

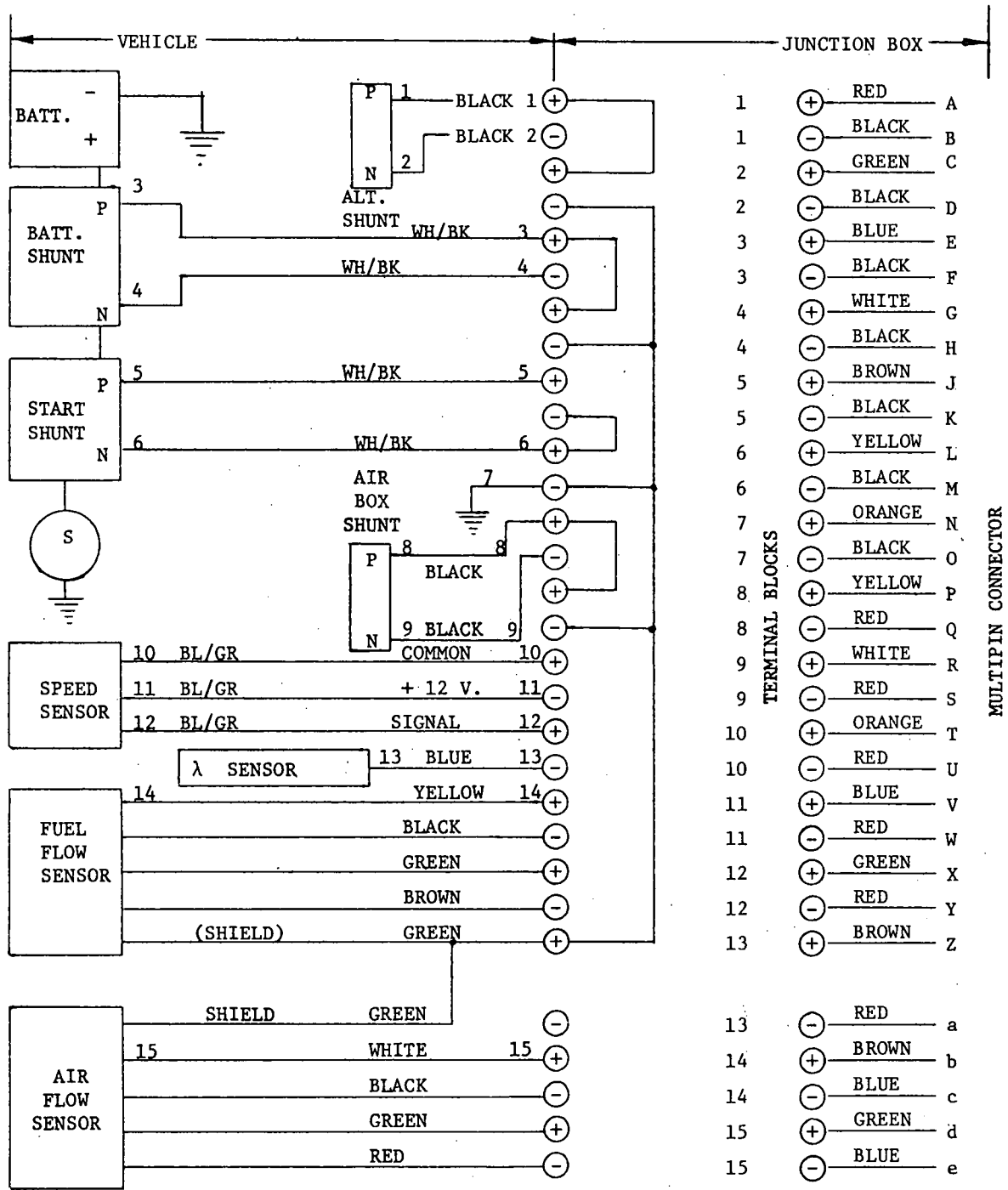
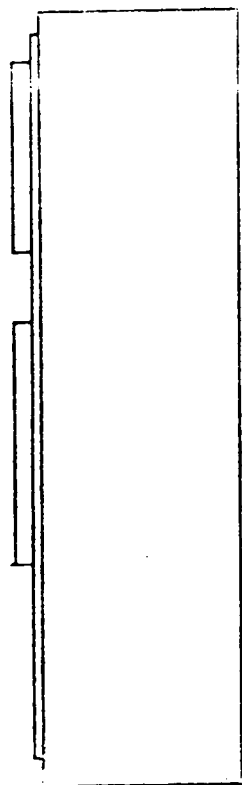
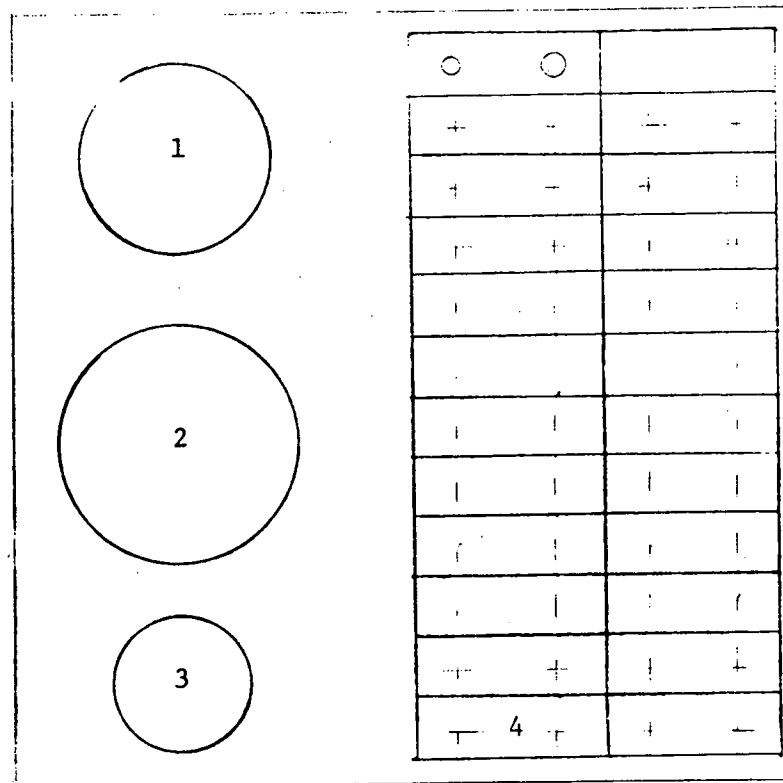

Fig. 2-II: M113A1 Electrical Wiring Diagram

WALL MOUNTED JUNCTION BOX



VEHICLE INTERIOR
SIDE



VEHICLE EXTERIOR
SIDE

- 1 AMPHENOL MULTIPIN CONNECTOR , NOT USED
- 2 AMPHENOL 52 PIN CONNECTOR , ELECTRICAL INPUTS
- 3 HOLE FOR A.C. INPUT
- 4 OMEGA THERMOCOUPLE PANEL , 24 T TYPE THERMOCOUPLE CONNECTORS

UNCLASSIFIED

UNCLASSIFIED

UNCLASSIFIED

UNCLASSIFIED

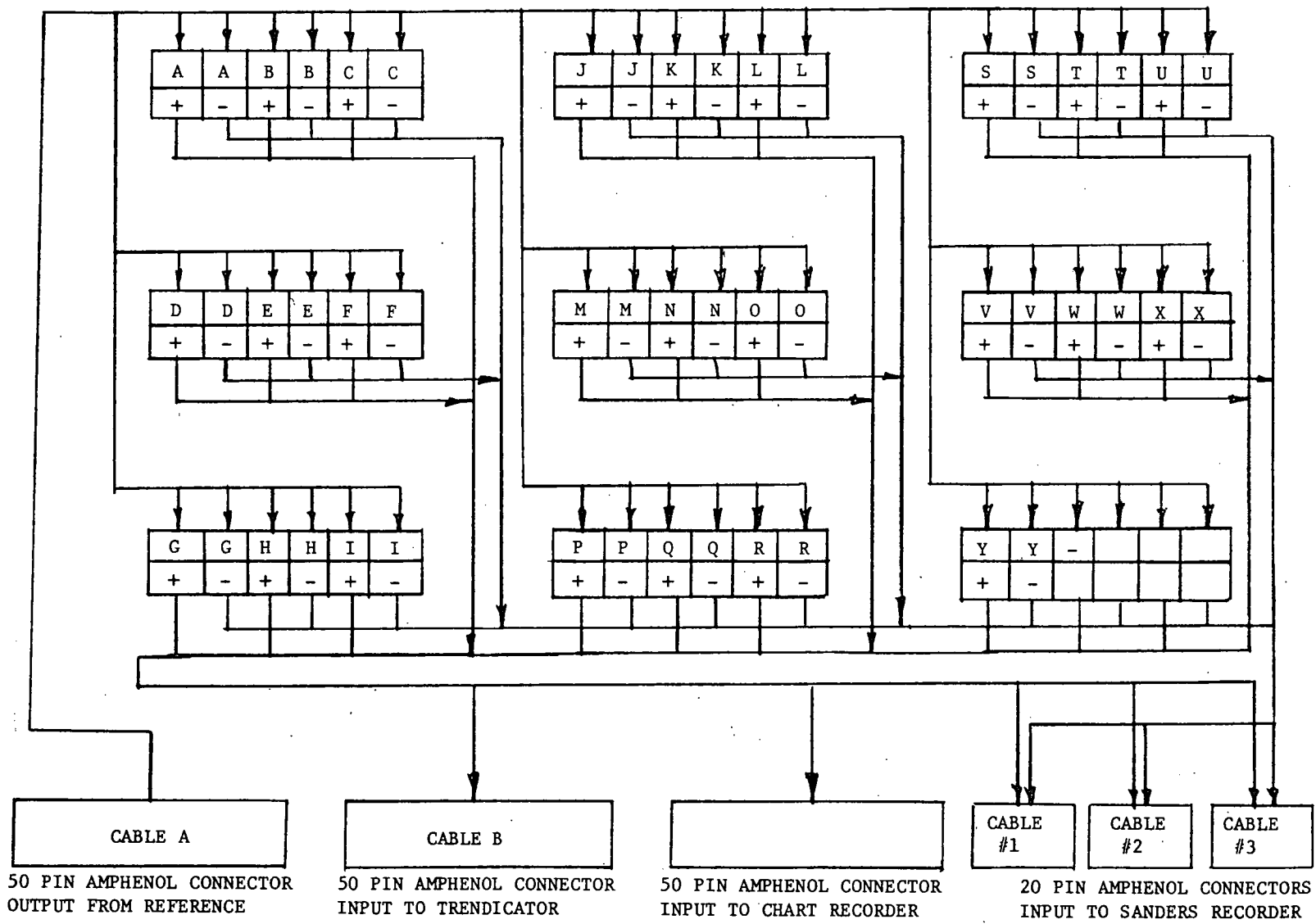

Fig. 4-II: Distribution Box "A"

UNCLASSIFIED

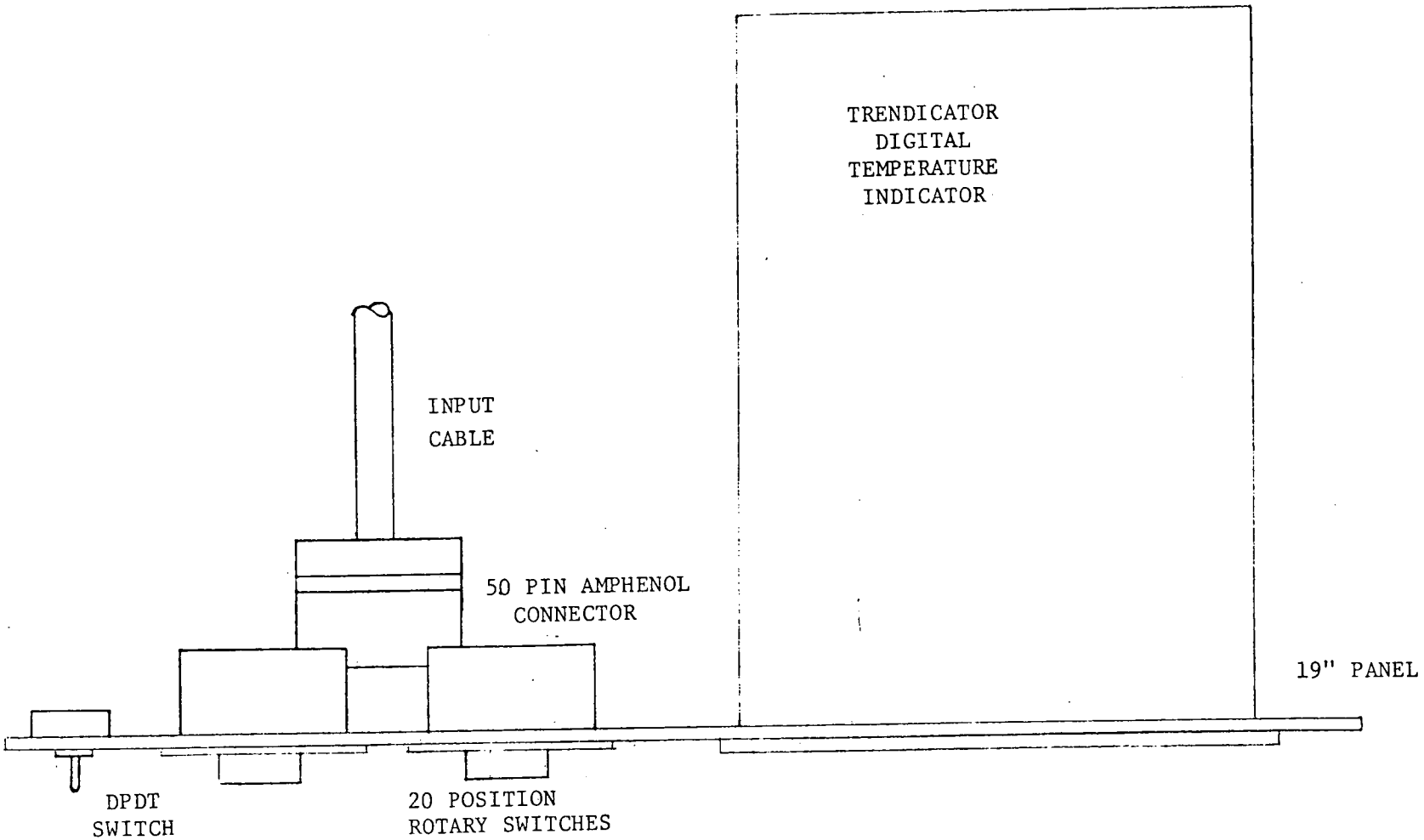

Fig. 5-II: Trendicator Panel Layout

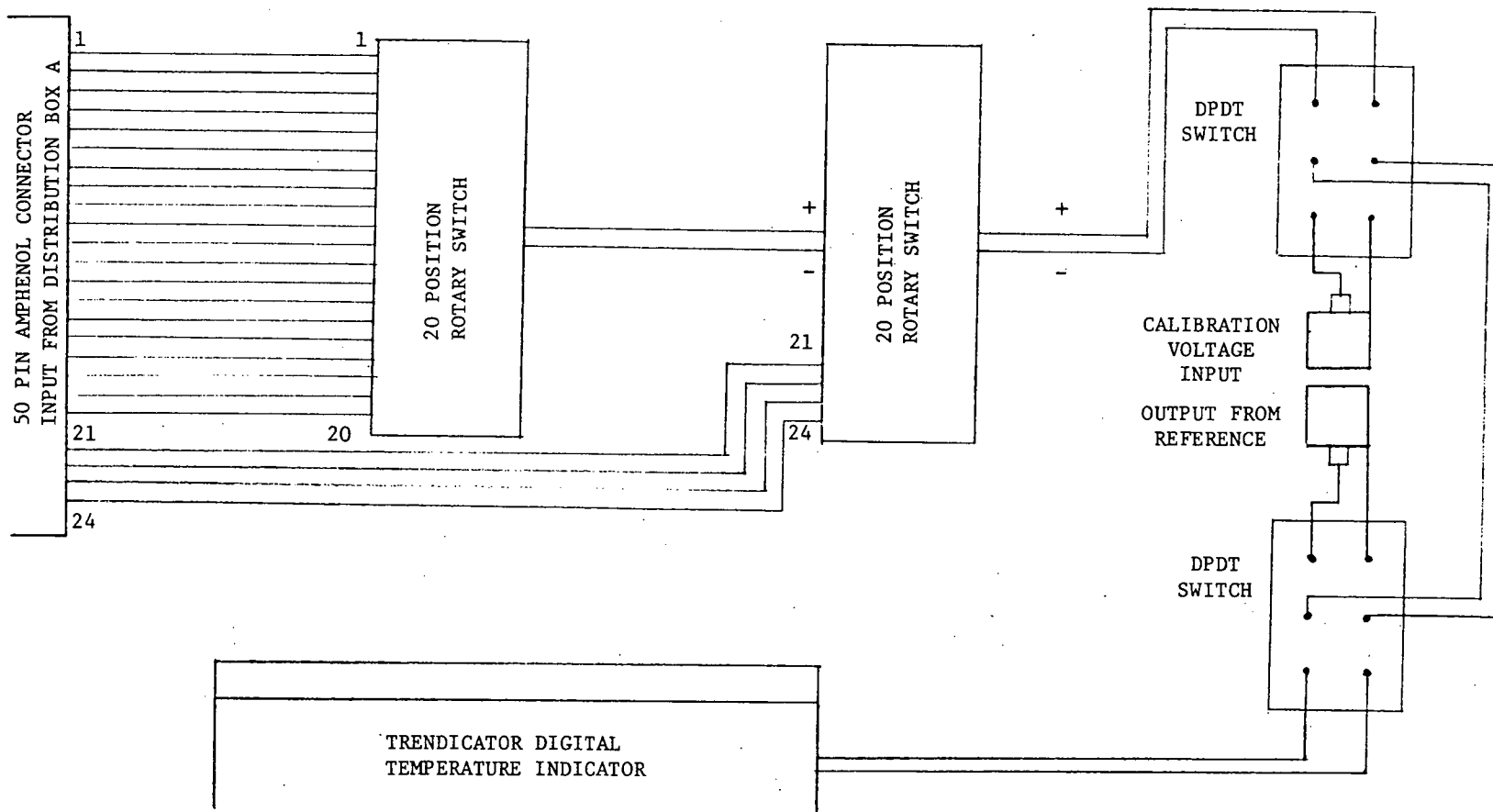
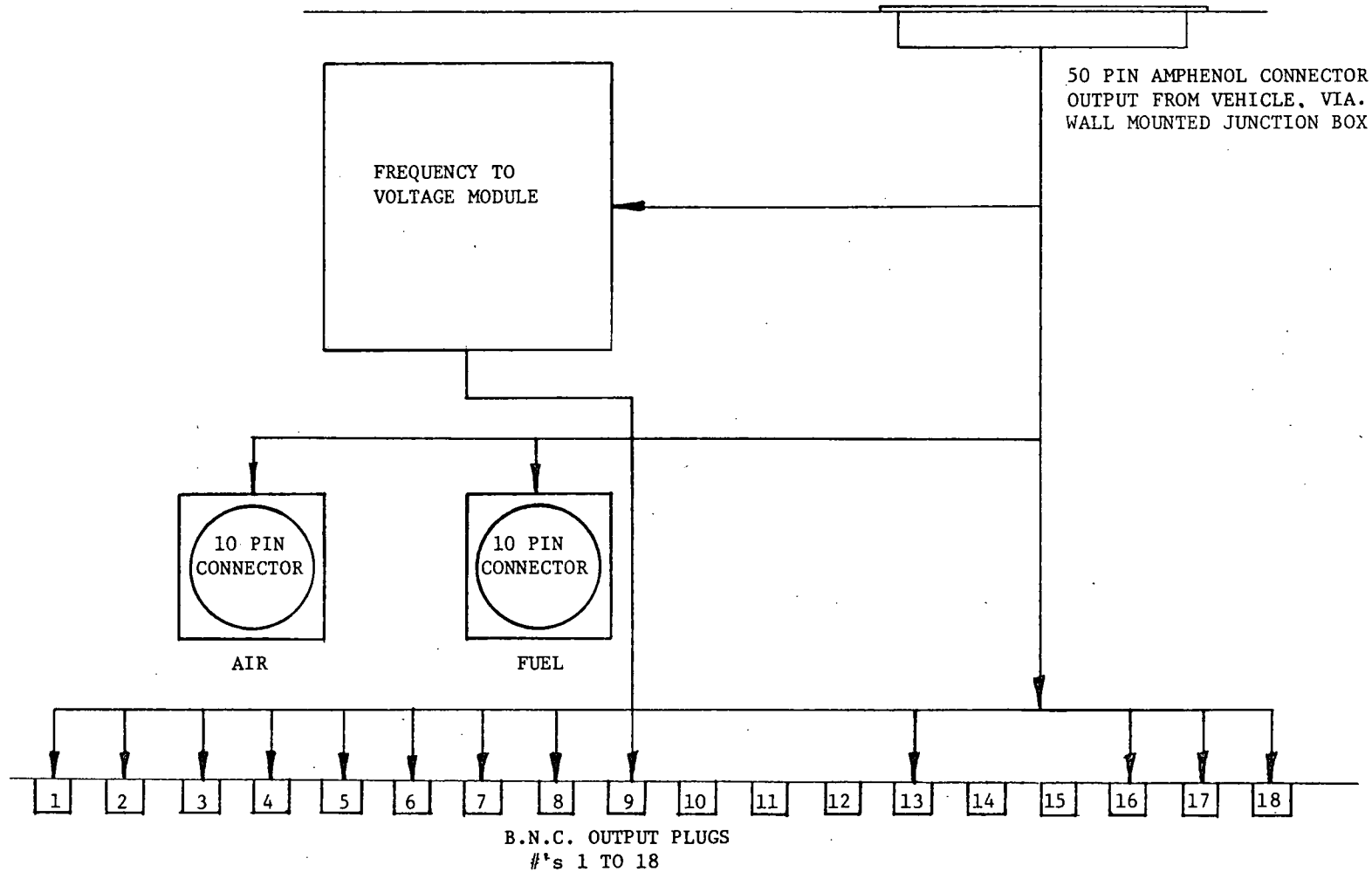

Fig. 6-II: Trendicator Panel



UNCLASSIFIED

UNCLASSIFIED

Fig. 7-II: Distribution Box "B"

UNCLASSIFIED

CABLE "A" CONNECTIONS

No.	Polarity	Wire Color	50 Pin Connector	52 Pin Connector	Wire Marking
1	+	Red	1	A	A
	-	Black	26	B	
2	+	White	2	C	B
	-	Black	27	D	
3	+	Green	3	E	C
	-	Black	28	F	
4	+	Blue	4	H	D
	-	Black	29	J	
5	+	Yellow	5	K	E
	-	Black	30	L	
6	+	Brown	6	M	F
	-	Black	31	N	
7	+	Orange	7	P	G
	-	Black	32	R	
8	+	White	8	S	H
	-	Red	33	T	
9	+	Green	9	U	I
	-	Red	34	V	
10	+	Blue	10	W	J
	-	Red	35	X	
11	+	Yellow	11	Y	K
	-	Red	36	Z	
12	+	Brown	12	a	L
	-	Red	37	b	
13	+	Orange	13	c	M
	-	Red	38	d	
14	+	White	14	f	N
	-	Green	39	g	
15	+	Blue	15	h	O
	-	Green	40	c	
16	+	Yellow	16	d	P
	-	Green	41	k	
17	+	Brown	17	m	Q
	-	Green	42	u	
18	+	Orange	18	p	R
	-	Green	43	g	
19	+	Blue	19	r	S
	-	White	44	s	
20	+	Yellow	20	t	T
	-	White	45	u	
21	+	Brown	21	v	U
	-	Blue	46	w	
22	+	Orange	22	x	V
	-	White	47	y	
23	+	White	23		W
	-	Brown	48	AA	
24	+	Brown	24	AB	X
	-	Blue	49	AC	
25	+	Red	25	AD	Y
	-	Blue	50	AE	

UNCLASSIFIED

CABLE "B" CONNECTIONS

No.	Polarity	Wire Color	Amphenol Pin No. (both ends)	Wire Marking
1	+	Red	1	A
2	+	White	2	B
3	+	Green	3	C
4	+	Blue	4	D
5	+	Yellow	5	E
6	+	Brown	6	F
7	+	Orange	7	G
8	+	White	8	H
9	+	Green	9	I
10	+	Blue	10	J
11	+	Yellow	11	K
12	+	Brown	12	L
13	+	Orange	13	M
14	+	White	14	N
15	+	Blue	15	O
16	+	Yellow	16	P
17	+	Brown	17	Q
18	+	Orange	18	R
19	+	Blue	19	S
20	+	Yellow	20	T
21	+	Brown	21	U
22	+	White	22	V
23	+	Brown	23	W
24	+	White	24	X
25	+	Red	25	Y

All Ground (negative) Pins soldered together. Red wire connects both ends (grounds) at Pin 43, wire color is red, marking is - .

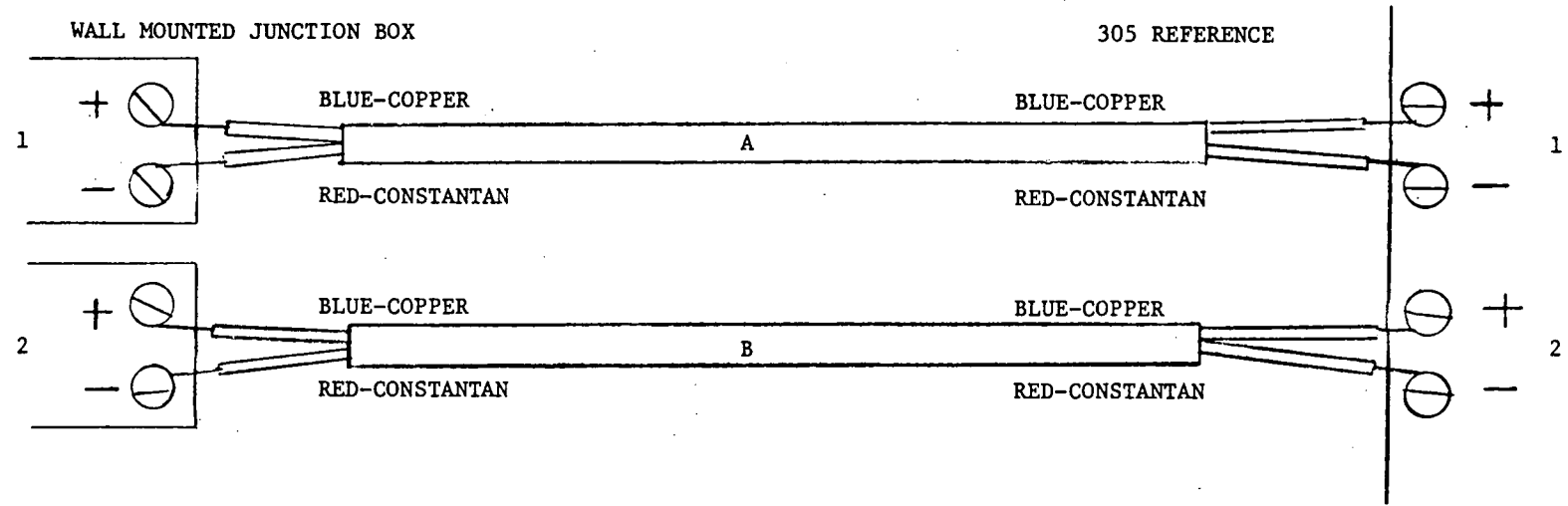

Fig. 8-II: Cable C

<u>CHANNEL NUMBER</u>	<u>WIRE MARKING</u>	<u>CHANNEL NUMBER</u>	<u>WIRE MARKING</u>
1	A	13	M
2	B	14	N
3	C	15	O
4	D	16	P
5	E	17	Q
6	F	18	R
7	G	19	S
8	H	20	T
9	I	21	U
10	J	22	V
11	K	23	W
12	L	24	X

UNCLASSIFIED

UNCLASSIFIED

UNCLASSIFIED

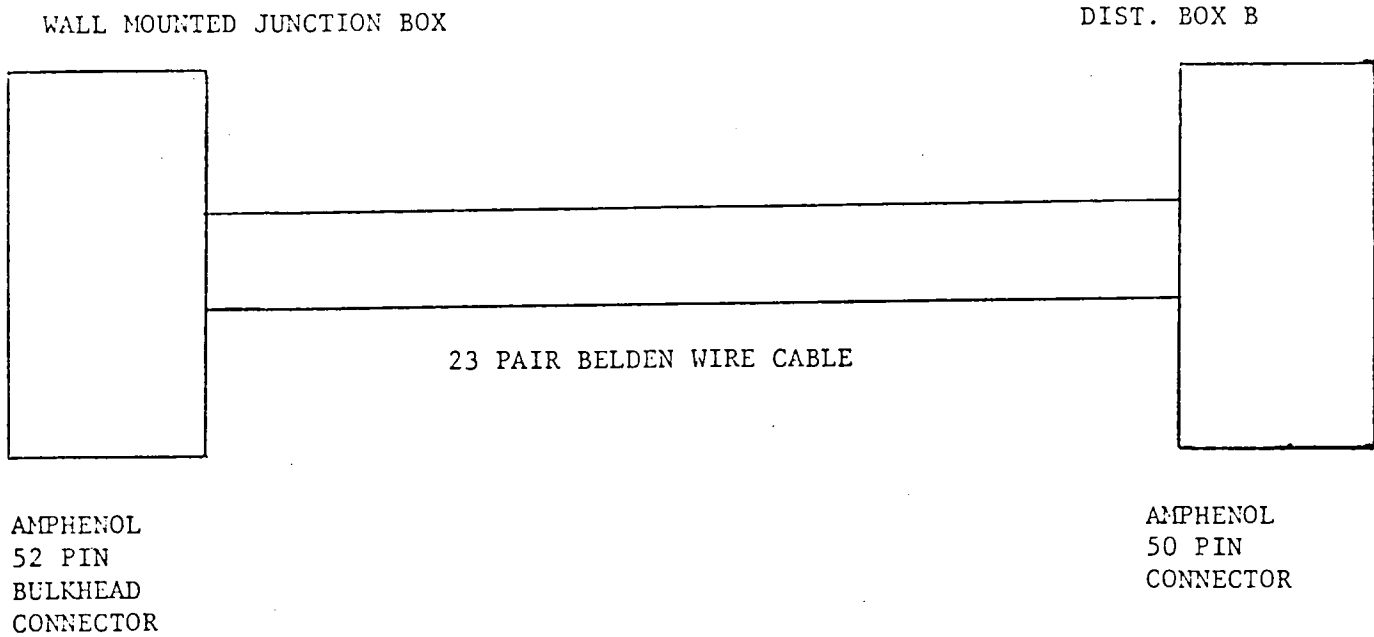

UNCLASSIFIED

Fig. 9-II: Cable D

UNCLASSIFIED

CABLE "D" CONNECTIONS

No.	Polarity	Wire Color	50 Pin Connector	52 Pin Connector	Wire Marking
1	+	Red	1	A	1
	-	Black	26	B	
2	+	White	2	C	2
	-	Black	27	D	
3	+	Green	3	E	3
	-	Black	28	F	
4	+	Blue	4	G	4
	-	Black	29	H	
5	+	Yellow	5	J	5
	-	Black	30	K	
6	+	Brown	6	L	6
	-	Black	31	M	
7	+	Orange	7	N	7
	-	Black	32	O	
8	+	White	8	P	8
	-	Red	33	Q	
9	+	Green	9	R	9
	-	Red	34	S	
10	+	Blue	10	T	10
	-	Red	35	U	
11	+	Yellow	11	V	11
	-	Red	36	W	
12	+	Brown	12	X	12
	-	Red	37	Y	
13	+	Orange	13	Z	13
	-	Red	38	a	
14	+	White	14	b	14
	-	Green	39	c	
15	+	Blue	15	d	15
	-	Green	40	e	
16	+	Yellow	16	f	16
	-	Green	41	g	
17	+	Brown	17	h	17
	-	Green	42	j	
18	+	Orange	18	k	18
	-	Green	43	m	
19	+	Blue	19	n	19
	-	White	44	p	
20	+	Yellow	20	q	20
	-	White	45	r	
21	+	Brown	21	s	21
	-	White	46	t	
22	+	Orange	22	u	22
	-	White	47	v	
23	+	Brown	23	w	23
	-	Blue	48	x	

UNCLASSIFIED

CABLE 1,2, 3 CONNECTIONS

	No.	Polarity	Wire Color	MIL. Connector Letter (both ends)	Wire Marking
<u>CABLE 1</u>	1	+	Red	A	A
		-	Black	B	
	2	+	White	C	B
		-	Black	D	
	3	+	Green	E	C
		-	Black	F	
	4	+	Blue	G	D
		-	Black	H	
	5	+	Yellow	J	E
		-	Black	K	
	6	+	Brown	L	F
		-	Black	M	
	7	+	Orange	N	G
		-	Black	P	
	8	+	White	Q	H
		-	Red	R	
	9	+	Green	S	I
		-	Red	T	
	10	+	Blue	U	J
		-	Red	V	
<u>CABLE 2</u>	11	+	Yellow	A	K
		-	Red	B	
	12	+	Brown	C	L
		-	Red	D	
	13	+	Orange	E	M
		-	Red	F	
	14	+	White	G	N
		-	Green	H	
	15	+	Blue	J	O
		-	Green	K	
	16	+	Yellow	L	P
		-	Green	M	
	17	+	Brown	N	Q
		-	Green	P	
	18	+	Orange	Q	R
		-	Green	R	
	19	+	Blue	S	S
		-	White	T	
	20	+	Yellow	U	T
		-	White	V	
<u>CABLE 3</u>	21	+	Brown	A	U
		-	Black	B	
	22	+	Orange	C	V
		-	White	D	
	23	+	White	E	W
		-	Yellow	F	
	24	+	Brown	G	X
		-	Blue	H	
	25	+	Red	J	Y
		-	Blue	K	
	26	+	White	L	Z

APPENDIX III

M113A1 ENGINE SPECIFICATIONS

APPENDIX III

M113A1 ENGINE SPECIFICATIONS

I Engine

Manufacturer Detroit Diesel Engine Division - GMC
 Model 5063-5299
 Series 6V53
 Type Two-cycle diesel-compression-ignition
 Idle speed 550-600 rpm
 No load governor speed 2,925 - 2,975 rpm

CAUTION: Do not let tachometer exceed 2,975 rpm under any circumstances.

Crankshaft rotation
 (viewed at pulley)
 (front) CW

Cylinder number:

Left bank front to rear 1L, 2L, 3L
 Right bank front to rear 1R, 2R, 3R
 Firing order 1L, 3R, 3L, 2R, 2L, 1R

Fuel types: Recommended

Grade DF-2 (VV-F-800) Do not use below +32°F
 Grade DF-1 (VV-F-800) Do not use below -10°F
 Grade DF-A (VV-F-800) Use for all temperatures
 CITE (MIL-F-46005) Use for all temperatures
 JP-5 (aircraft turbine engine) Emergency conditions above -40°F
 Fuel Used: 3-GP-6M Type AA, Cetane number 40 (minimum), Cetane Index
 40 (minimum), Pour Point -51°C (Supplier Imperial Oil)

II Transfer Gearcase

Manufacturer FMC Corporation
Gear ratio 1.286:1
Power takeoffs 3

III Transmission

Manufacturer Allison Division - GMC
Model TX100-1
Speeds 3 fwd, 1 rev
Ranges 4 fwd, 1 rev

IV Steering Control Differential

Manufacturer FMC Corporation
Model DS200
Suspension points 3

APPENDIX IV

PHYSICAL MEASUREMENT LAYOUT

UNCLASSIFIED

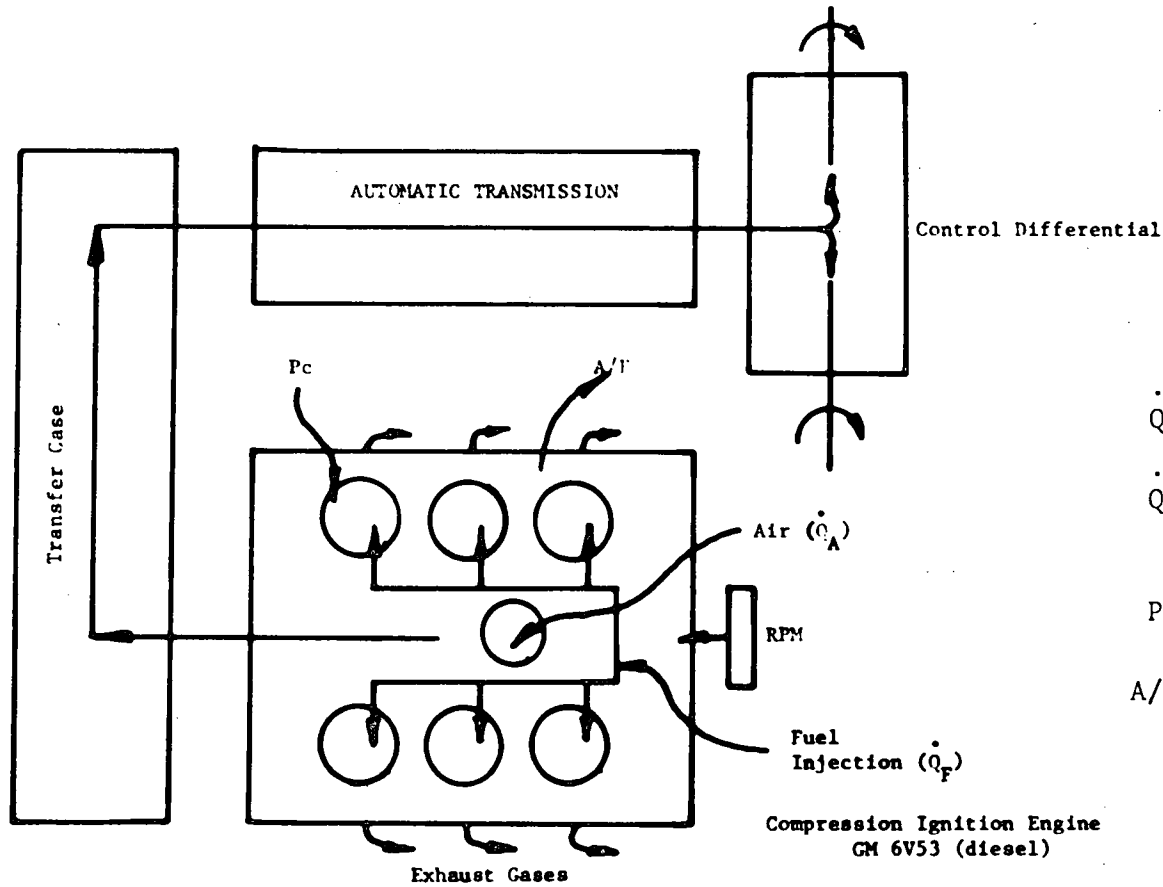

- \dot{Q}_A - Air Flow Rate
(Autotronic Vane Type Trans.)
- \dot{Q}_F - Fuel Flow Rate
(Fluid Dyne Positive Displ. Pump)
- Pc - Cylinder Pressures
(Kistler Pressure Trans.)
- A/F - Air Fuel Ratio
(Bosch Ionized Exhaust Gas Sensor)

UNCLASSIFIED

Figure 1-1V - System Layout

Fig. 2-IV: Pictorial of Measurements Locations - G.M. 6V53

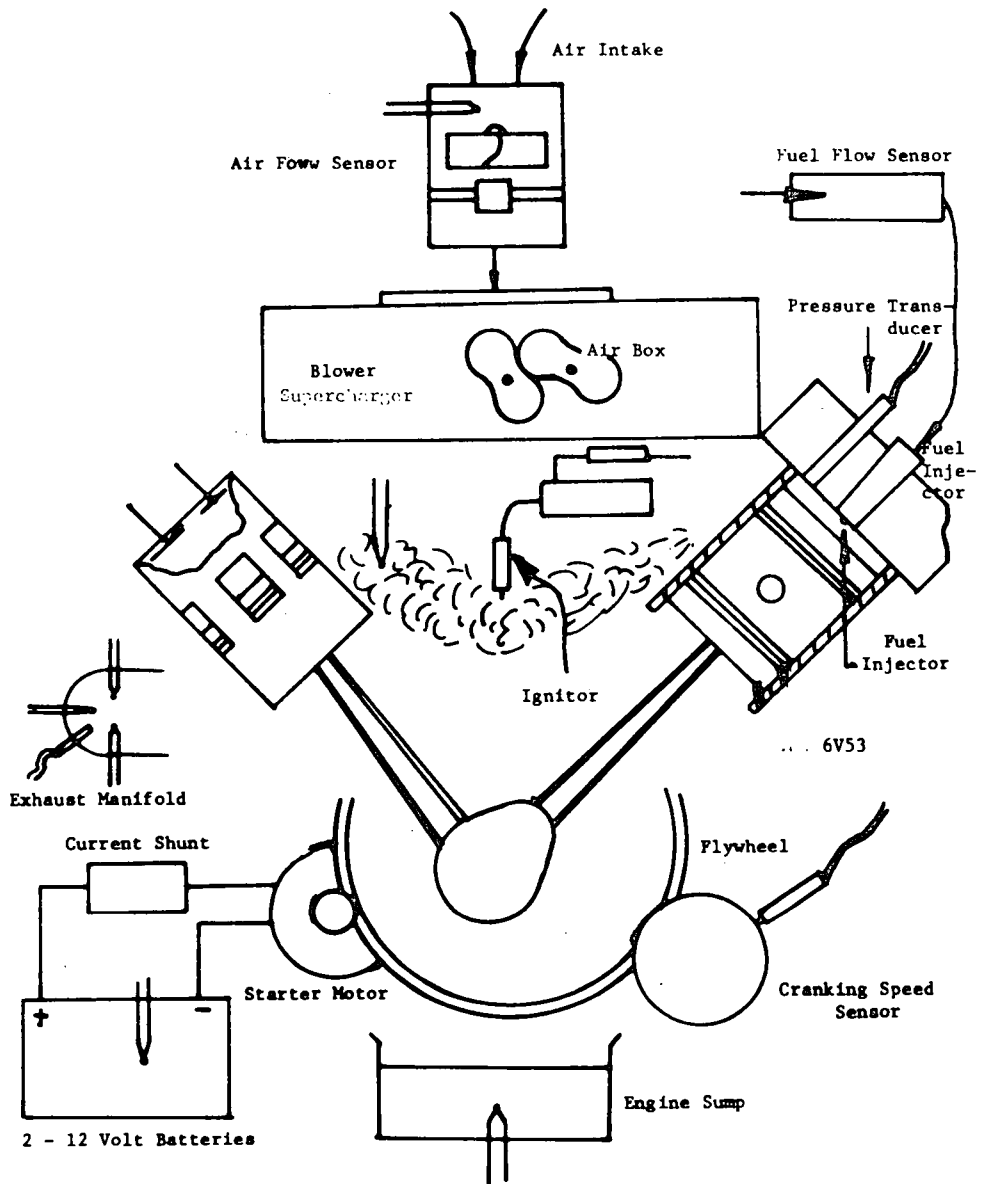
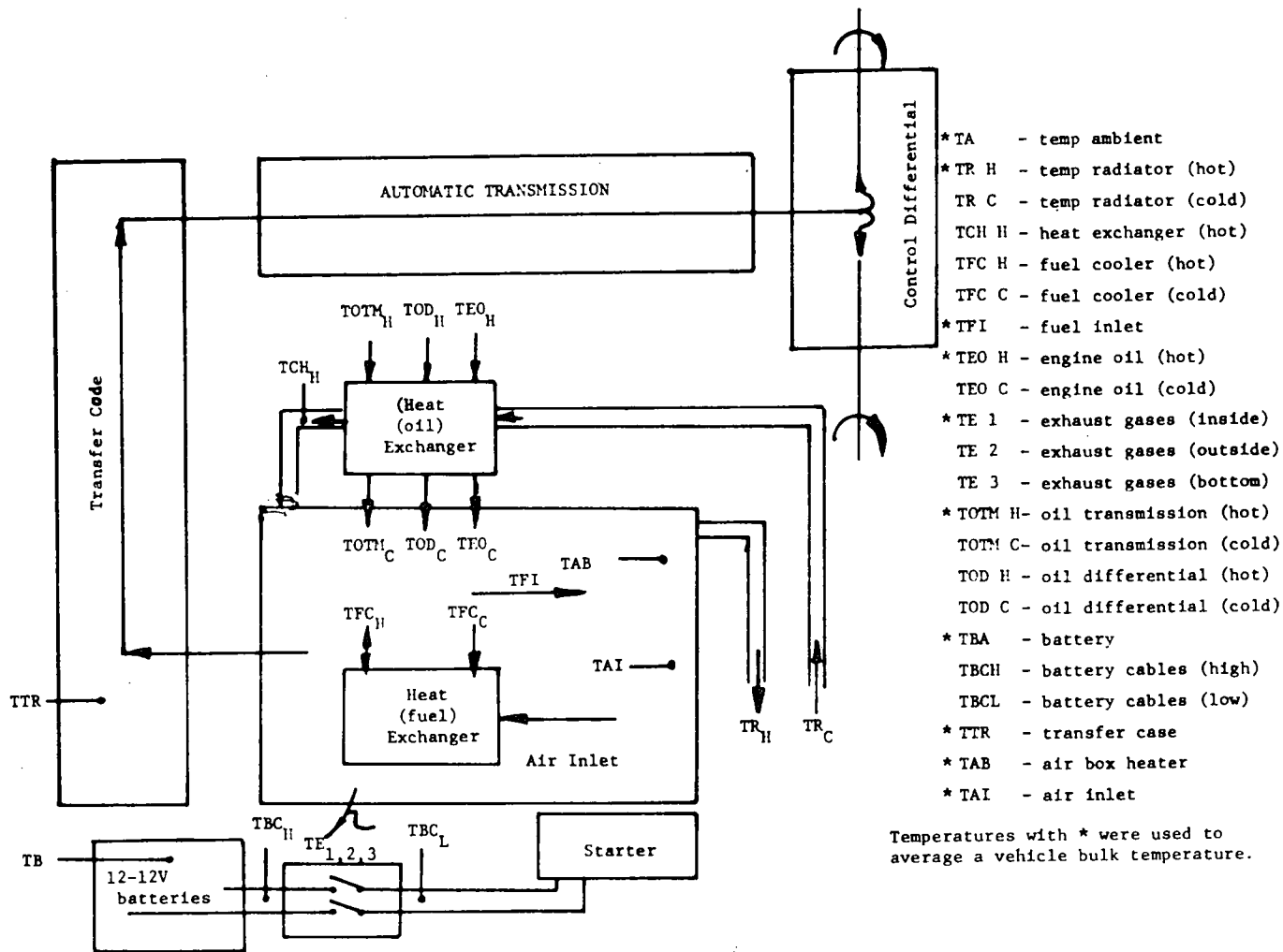

Figure 3-IV - System Temperature



UNCLASSIFIED

UNCLASSIFIED

Figure 4-IV - Fuel System (Fuel Flow Rate Measurement)

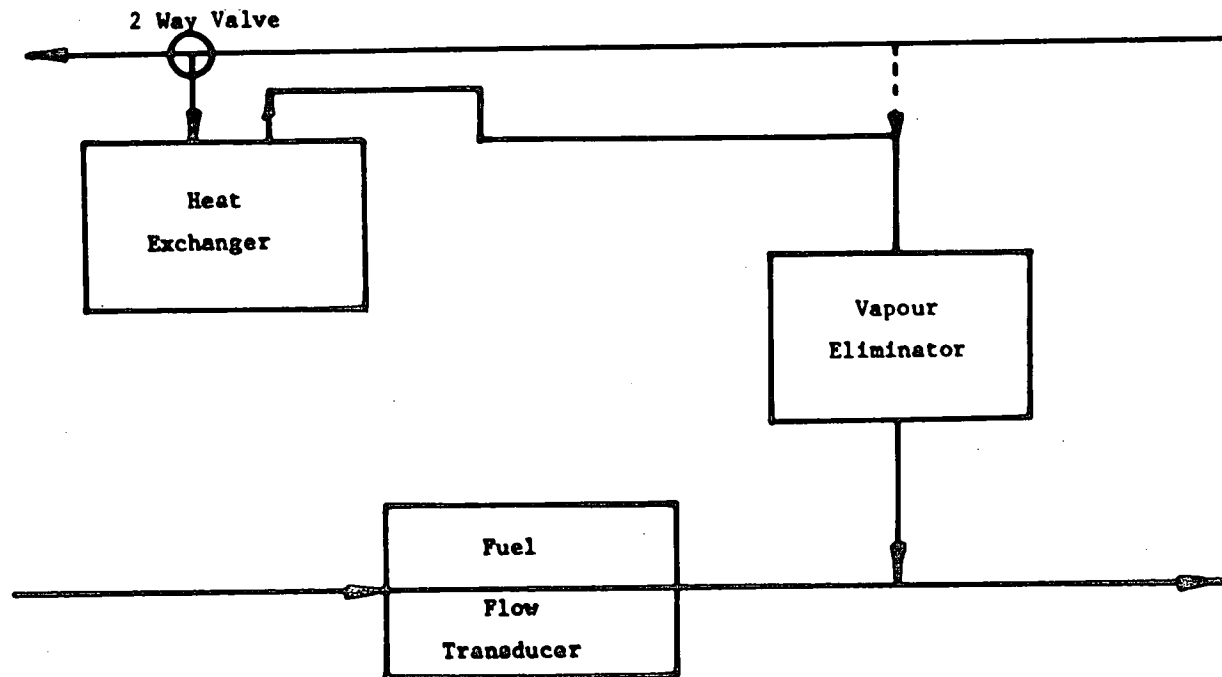

UNCLASSIFIED

UNCLASSIFIED

Figure 5-IV - Electrical System Parameters

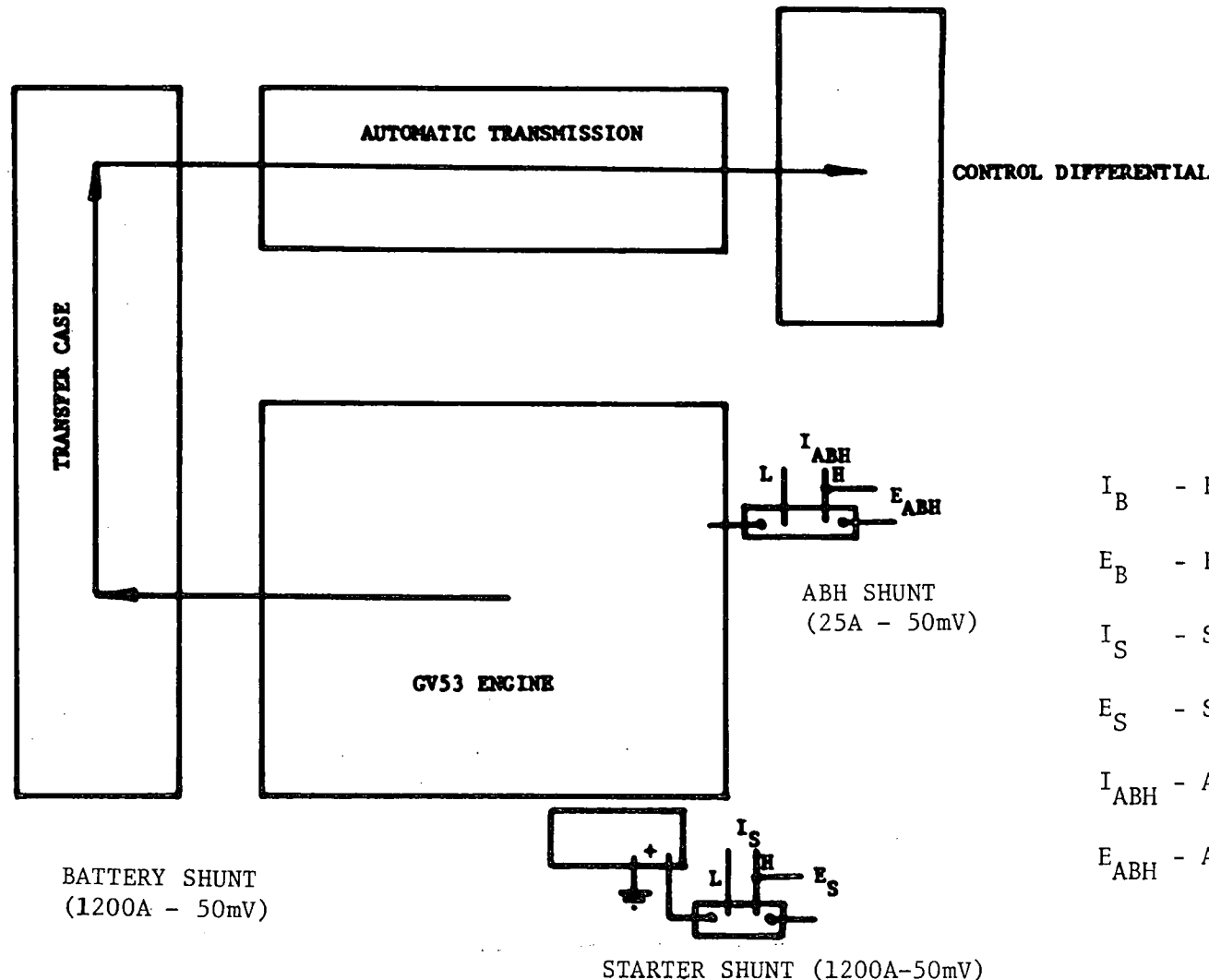

- I_B - Battery Current
- E_B - Battery Voltage
- I_S - Starter Current
- E_S - Starter Voltage
- I_{ABH} - Air Box Heater Current
- E_{ABH} - Air Box Heater Voltage

UNCLASSIFIED

UNCLASSIFIED

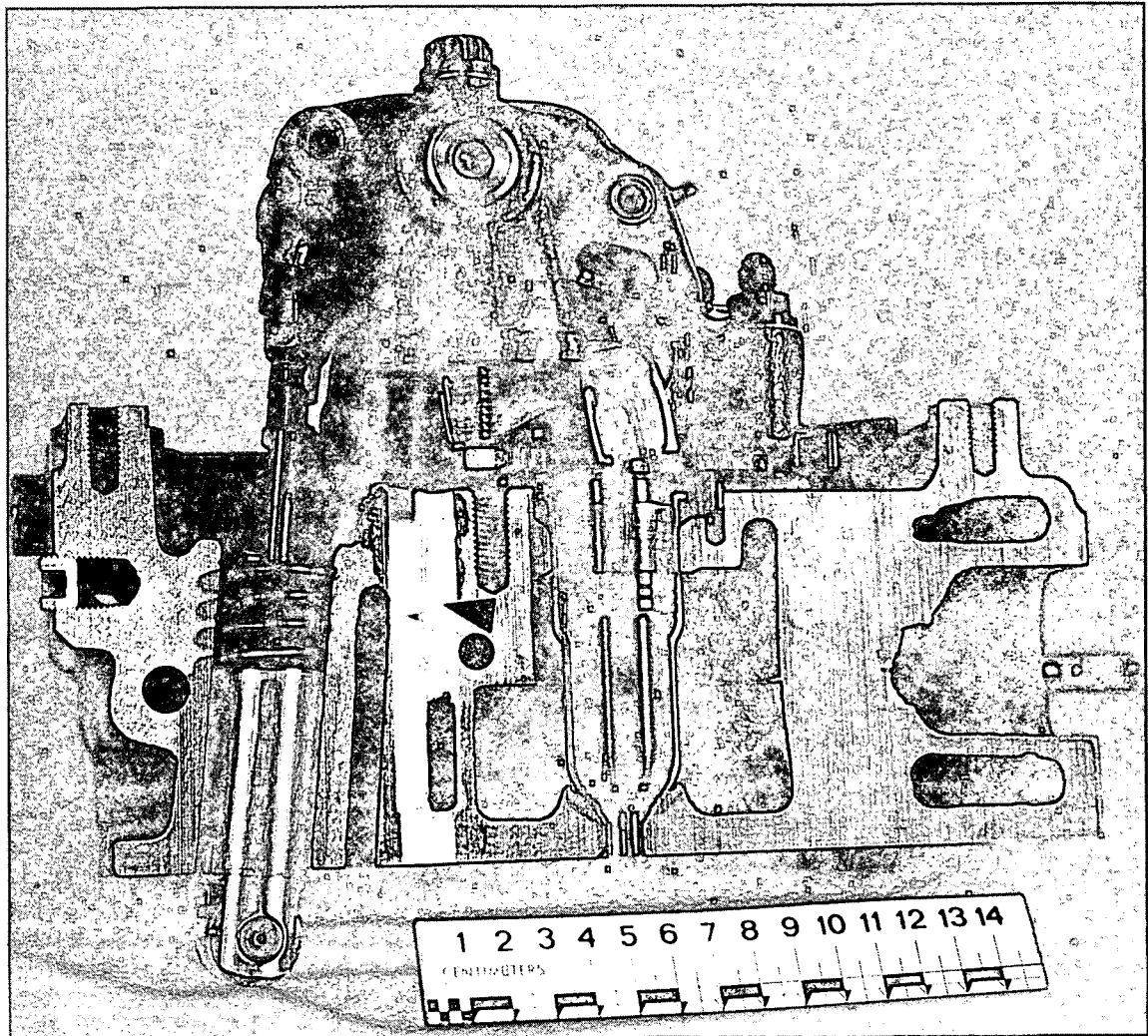

Figure 6-IV - Cylinder Head Pressure Transducer Locations

TABLE 1-IV

<u>Measurements</u>	<u>Recording System</u>
Temperatures - T (°C)	Sanders ADR II Recorder
Starter Current - I _S	Gulton Chart Recorder
Starter Voltage - E _S	" " "
Airbox Heater Current - I _{AB}	" " "
Analog RPM - N _A	" " "
¹ Air Mass Flow Rate - m _A	" " "
² Fuel Flow Rate - Q _f	" " "
Cylinder Pressure - P _C	Gulton Chart Recorder and S.E. Labs Tape Recorder
Cold Soak Time	Digital Clock
Real Time	Seiko Digital Clock

1,2 - m_A, Q_f both have digital displays as well.

APPENDIX V

MINI-STARTING TEST PACKAGE

The 'Mini-Starting Test Package' monitored the following measurements:

8 Channel Chart Recorder	{	1. RPM - Pulse	- N_p
		2. RPM - Analog	- N_A
		3. Starter Voltage	- E_S
		4. Starting Current	- I_S
Temperature Recorder	{	1. Ambient Temperature	- T_A
		2. Battery Temperature	- T_B
		3. Air Inlet Temperature	- T_{AI}
		4. Engine Oil Temperature	- T_{EO}
		5. Coolant Temperature	- T_C
		6. Radiator Temperature	- T_R
		7. Fuel Inlet Temperature	- T_{FI}

The calibrated devices to sense the above parameters are shown in Figure 1-V. The RPM was sensed by the two (Air Pax) 'Hall-effect' zero velocity transducers shown at the top of the Figure beside the gear. The top transducer was mounted so that it sensed the passing teeth on the 12 pitch, 72 tooth gear. This signal was processed through a (Intech) frequency to voltage converter to produce the necessary analog response (N_A). The bottom velocity transducer sensed the passing dog, shown welded to the side

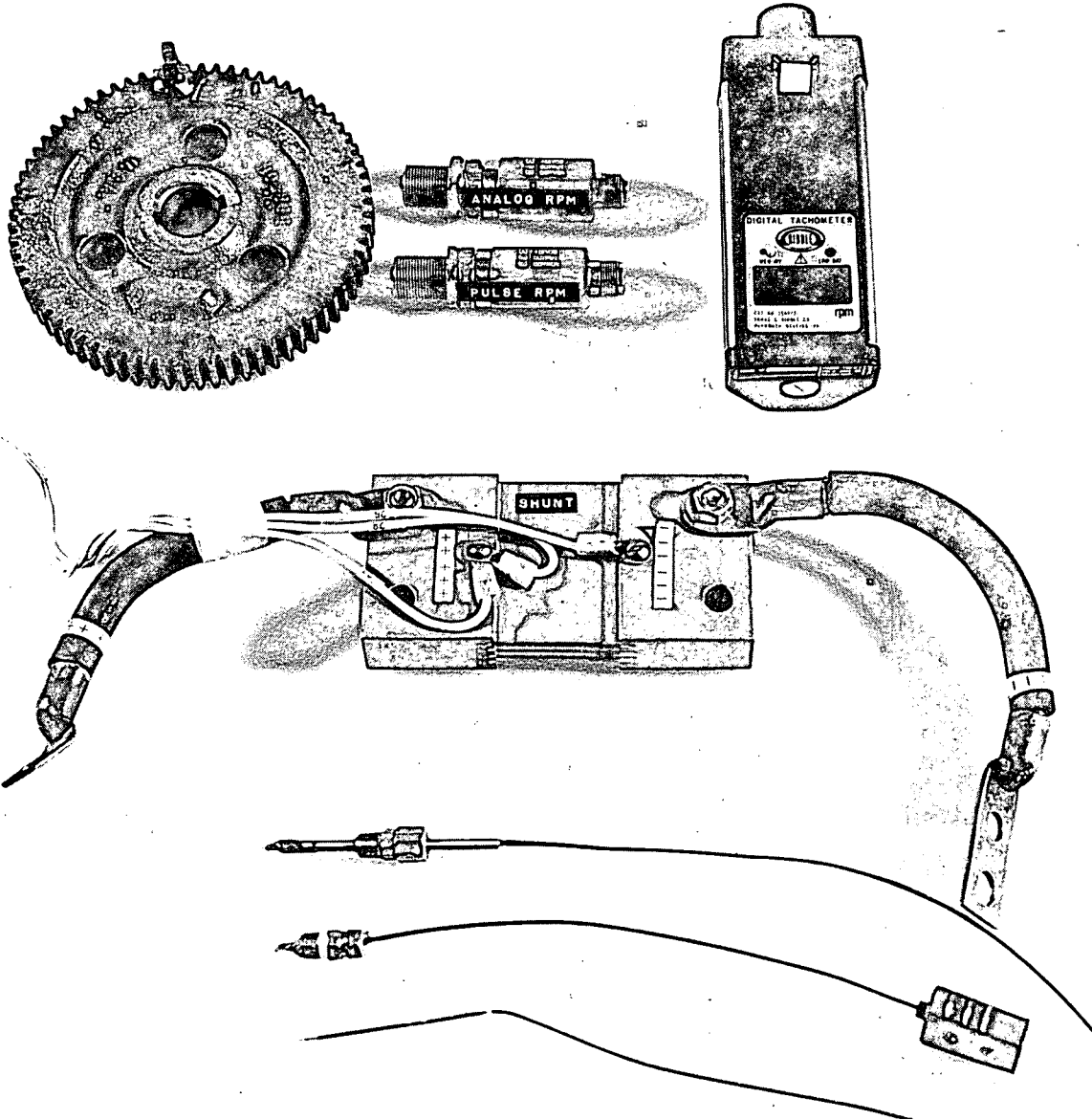

Fig. 1-V: Calibrated Devices of Mini-Starting Test Package

of the gear. This signal (N_p) was sent directly to the chart recorder and gave a single pulse every revolution of the gear. This enabled the number of cranking revolutions to be counted. Due to the limited space conditions in the crowded engine compartment, it was not practical to mount the gear directly to the crankshaft pulley. This resulted in the necessary determination of the RPM ratio between gear location and the crankshaft. This ratio was found by diameter ratio measurement and by using the infra red hand held tachometer shown beside the velocity transducers of Figure 1-V. This device has the ability to sense a self adhering reflective sticker on a moving part. Its unique feature is that it can be held as far away as 1-2 feet from the moving shaft. This is advantageous in the close confines of the M113 and other military engine compartments.

The starter current was measured with a 1200 Amp - 50 mV shunt shown beneath the velocity measurement devices. The voltages were between the high side of the shunt and the vehicle ground.

The temperature was sensed by thermocouples of varying reach mounted in fittings similar to the 3 thermocouples shown at the bottom of Figure 1-V. The thermocouple wires were set in the fittings by quicksetting high temperature epoxy. Epoxy was used as an insulator to avoid stray ground currents that frequent vehicle components. The bottom glass encased thermocouple was used for the corrosive environment of the battery.

APPENDIX VI

DATA RECORDING AND PROCESSING

DATA RECORDING

Temperatures were recorded with a Sanders Instrument Data Acquisition System ADR II. The Sanders ADR II multi-channel digital recorder (1-VI)* accepts directly analog and digital voltage signals from transducers. The recording medium is a standard cassette tape. Data is recorded in digital format at 800 bits/inch. There is a capability of monitoring 64 different channels. The recording format is:

Header, 3 + 3 digits - channel 0 and 1

Time, - channel 2

Voltage, signals - channel 3 to 77 (total 61 channels for voltage measurements)

The recording for one channel consists of a six digit number:

ABCDEF.

AB represents the channel number, DEF is the voltage in millivolts, and C is a code for manual mark (MM). For voltage (V), voltage sign (S), and voltage overload (VO), C can be any digit 0 to 9. Using the binary code for digits 0 to 9 the following chart Table 1-VI is obtained.

* Numbers in parenthesis refer to references at the end of the Appendix.

TABLE 1-VI

C	VO	S	V	MM
0	0	0	0	0
1	0	0	0	1
2	0	0	1	0
3	0	0	1	1
4	0	1	0	0
5	0	1	0	1
6	0	1	1	0
7	0	1	1	1
8	1	0	0	0
9	1	0	0	1

Time is written in seconds up to 3600 seconds for one hour.

Figure 1-VI shows the time function of the recorder display.

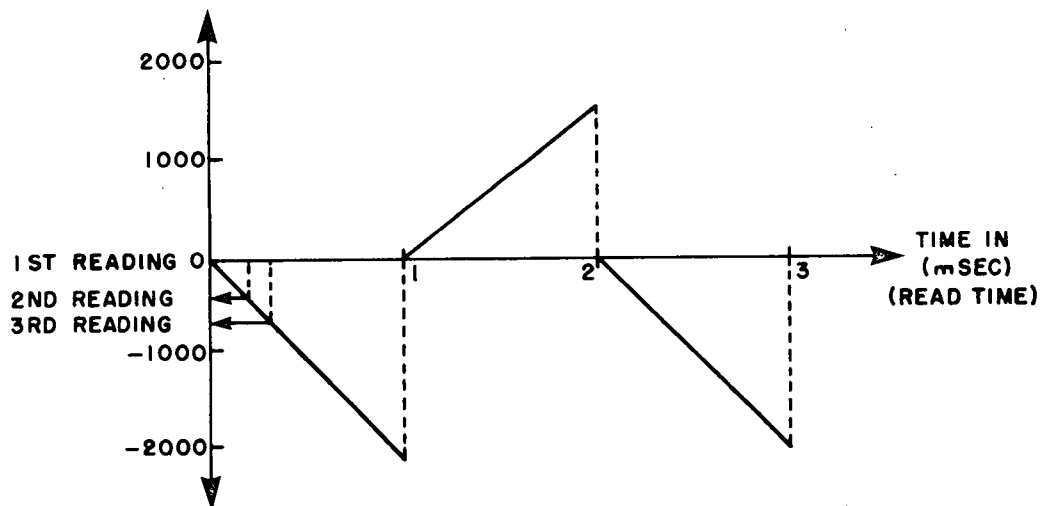

Figure 1-VI: Time function

DATA PROCESSING

There are two computer programmes necessary for processing the recorded data. Both programmes are written in Xerox extended Fortran IV.

Computer programme "SANDATA", shown in Listing 1-V1* converts the Sanders data recording to formulated data on the line printer, CRT or disc.

The data source can either be a free format $\frac{1}{2}$ inch tape or a disc file (copy of tape to disc). The data recorded on cassette has to be converted to formats suitable for computer processing by means of a special reproducing unit or by a Sanders Instrument process (the latter was used for this study).

The input for the computer terminal is:

- 1) First register (record) number.
- 2) Last register (record) number.
- 3) Check list for subroutines "buffer" and "decode" yes or no are required.
- 4) Maximum channel number (if less than 61 channels).

The output has 8 result columns with:

- 1) Channel number (octal)
- 2) Header or time or measured voltage (depends on channel number).
- 3) Manual mark (0 to 1).
- 4) Input overload (0 to 1).

For output only on CRT or terminal:

- 1) Check list.
- 2) Number of registers (recordings per 600 Bytes).
- 3) Number of results (channels).

* Listing 1-V1, 2-V1, Figure 2-VI and Figure 4-VI are at the end of Appendix.

Figure 2-V1 shows an example of the input and output for a teletype terminal. Programme "Sandata" can be used for any measurements recorded with Sanders ADR 11 recorder.

Programme "SANTEMP" is a means for converting thermocouple voltage measurements to temperature in degrees celsius. The thermocouples used were "T"-type copper constantan. The temperature vs voltage function of the thermocouple is given by Figure 3-V1. Reference (2-V1) provides a chart for thermoelectric voltages and temperatures in the range $-50^{\circ}\text{C} \leq T \leq +8$.

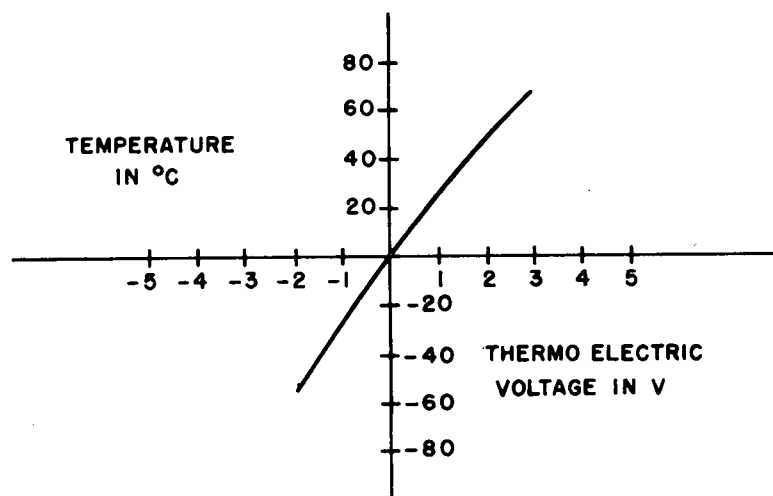

Figure 3-V1

The function in Figure 3-V1 can be approximated by the equations

$$\text{VI-1} \quad T = 25.66E - 0.54E^2 \quad \text{for } 0^{\circ}\text{C} \leq T \leq +80^{\circ}\text{C}.$$

$$\text{VI-2} \quad T = 25.73E - 0.55E^2 + 0.275E^3 \quad \text{for } -50^{\circ}\text{C} \leq T \leq 0^{\circ}\text{C}.$$

where T = temperature in $^{\circ}\text{C}$ and E = thermoelectric voltage in volts.

The errors using these approximations are -0.1°C at 20°C to 40°C , $+0.1^{\circ}\text{C}$ at 70 to 80°C and $+0.3^{\circ}\text{C}$ at -50°C . The equations are used in the programme "SANTEMP" Listing 2-V1 to calculate the temperatures for the

measured voltages. The input, output and definitions are explained in the programme with comment statements. The programme can be easily adapted to other than temperature measurements by changing statements 181 to 198 and the output format. Figure 4-VI illustrates the input and output with a line printer.

REFERENCES

- (1-VI) Technical Manual, "Sanders ADR II Recorder", Sanders Geophysics Ltd., 250 Herzberg Road, Kanata, Ontario K2K 1X3
- (2-VI) "The Omega Temperature Measurement Handbook 1975", Omega Engineering Inc., Box 4047, Stanford, Conn., USA 06907.

LISTING (L) 1-VI

```

1.000 C          *** SANDATA ***
1.500 C
2.000 C THIS PROGRAM CONVERTS DIGITAL DATA FROM SANDER ADR II
3.000 C TO FORMATED DATA ON LINE PRINTER, TERMINAL OR DISC.
3.500 C LANGUAGE: XEROX EXTENDED FORTRAN IV.
4.000 C
5.000 C DATA SOURCE: FREE FORMAT TAPE COPIED ON A DISC FILE.
6.000 C
7.000 C OUTPUT:
8.000 C     CHANNEL (OCTAL), HEADER/TIME/VOLTAGE,
9.000 C     MANUAL MARK (0 OR 1), INPUT OVERLOAD (1).
10.000 C
11.000 C     CHANNEL 0 AND 1: HEADER,
12.000 C     "      2:      TIME IN SEC.,
13.000 C     "      3 TO 77: VOLTAGE,
14.000 C     IN 8 COLUMNS.
15.000 C
16.000 C INPUT FROM TERMINAL:
17.000 C     EXAMPLE FOR COMMANDS:
18.000 C     FORT4 SANDATA OVER SDB
19.000 C     SET F:1/DATAFILE;IN
20.000 C     SET F:3 UC;OUT
21.000 C     RUN SDB
22.000 C     THEN:
23.000 C     FIRST REGISTER NUMBER,
24.000 C     LAST REGISTER NUMBER,
25.000 C     CHECK LIST FOR BUFFER/DECODER, YES/NO,
26.000 C     MAX. CHANNEL NUMBER (OCTAL, LESS OR EQUAL 77).
27.000 C
28.000 C OUTPUT ON TERMINAL:
29.000 C     ACTNR:  ACTUAL REGISTER NUMBER
30.000 C     LASTNR:  LAST REGISTER NUMBER
31.000 C     ISO:     STATUS OF BUFFER OPERATION
32.000 C     NWI:     NUMBER OF INPUT WORDS
33.000 C     EC:      ERROR CODE (SEE XEROX LANG. REF. MAN. PG. 51)
34.000 C     NC:      NUMBER OF CHARACTERISTICS ACT. PROC.
35.000 C
36.000 C     NRREG:   NUMBER OF REGISTERS
37.000 C     IRESULT: NUMBER OF RESULTS
38.000 C
39.000 C
40.000 C DEFINITIONS:
41.000 C
42.000 C
43.000 C FOR BUFFER/DECODE:
44.000 C
45.000 C     IBS:  STARTING LOCATION OF THE INTERNAL BUFFER
46.000 C     ISO:  INDICATION OF THE STATUS OF THE OPERATION
47.000 C           2= SUCCESSFUL COMPLETION
48.000 C           3= END-OF-FILE ENCOUNTERED
49.000 C           4= OPERATION COMPLETED BUT ERROR HAS
50.000 C             OCCURED
51.000 C     NWI:  ACTUAL NUMBER OF INPUT WORDS
52.000 C     IEC:  ERROR CODE (SEE LANGUAGE REF. MAN. PG. 51)
53.000 C     NC:   NUMBER OF CHARACTERS ACTUALLY PROCESSED
54.000 C     LI:   TO INITIATE CHECK LIST, 1=YES, 0=NO.
55.000 C

```

LISTING (L) 1-VI

```

56.000 C REGISTER:
57.000 C
58.000 C NRREG: NUMBER OF REGISTERS
59.000 C NRA: ACTUAL REGISTER NUMBER
60.000 C NRSTART: FIRST REGISTER
61.000 C NREND: LAST REGISTER
62.000 C NRCH: MAX. CHANNEL NUMBER (LESS OR EQUAL 77)
63.000 C CANAL: CHANNEL NUMBER (OCTAL), TWO DIGITS
64.000 C DATA: UNDECODED FOUR-DIGIT RESULTS
65.000 C COUNT: SUBSCRIPT; COUNTS NUMBER OF CHANNELS
66.000 C IRESULT: COUNTS NUMBER OF RESULTS
67.000 C
68.000 C DECODING OF THE FIRST CHARACTER OF DATA:
69.000 C
70.000 C IDON: INTEGER FOR FIRST DIGIT
71.000 C MARK: MANUAL MARK (0 OR 1)
72.000 C VOLT: 0 OR 1 FOR VOLTAGE OVERLOAD
73.000 C IDATA: INTERMEDIATE RESULT
74.000 C OVERFLO: FOR VOLTAGE OVERLOAD
75.000 C RESULT: DECODED DATA
76.000 C
77.000 C OUTPUT:
78.000 C
79.000 C NO: SUBSCRIPT FOR OUTPUT FORMAT
80.000 C CANA: CHANNEL NUMBER (OCTAL)
81.000 C RESU: DECODED DATA
82.000 C OVERFL: VOLTAGE OVERLOAD
83.000 C MARK: MANUAL MARK
84.000 C N, NORE: COUNTER
85.000 C
86.000 C
87.000 C FORMATS:
88.000 C
89.000 10 FORMAT (100(I2,I4))
90.000 15 FORMAT (1X,I4,3X,I4,3X,I1,2X,I3,2X,I1,1X,I3)
91.000 20 FORMAT (8(2X,I2,F7.3,I2,I2,1X))
92.000 C
93.000 C
94.000 C
95.000 C PROGRAM
96.000 C
97.000 C
98.000 DIMENSION IBS(150),CANAL(100),DATA(100)
99.000 DIMENSION CANA(10),RESUL(10),MAR(10),OVERFL(10)
100.000 OUTPUT ' -----'
101.000 OUTPUT ' '
102.000 OUTPUT ' '
103.000 C TERMINAL INPUT:
104.000 OUTPUT 'NUMBER OF FIRST REGISTER='
105.000 INPUT NRSTART
106.000 OUTPUT 'NUMBER OF LAST REGISTER='
107.000 INPUT NREND
108.000 NRREG=1.+NREND-NRSTART
109.000 OUTPUT 'CHECK LIST? YES=1 OR NO=0.'
110.000 INPUT LI

```

*

LISTING (L) 1-VI

```

111.000 30  OUTPUT 'MAX. CHANNEL NUMBER (OCTAL, LESS OR EQUAL 77)'
112.000      INPUT NRCH
113.000      IF(NRCH.GT.77)GO TO 30
114.000      NRJ=NRCH-10.*INT(NRCH/10)
115.000      IF(NRJ.LT.8)GO TO 35
116.000      OUTPUT 'NUMBER IS NOT OCTAL! ENTER AGAIN!'
117.000      OUTPUT ' '
118.000      GO TO 30
119.000 35  OUTPUT ' '
120.000      OUTPUT ' '
121.000      OUTPUT ' '
122.000      IF(LI.LT.1)GO TO 40
123.000      OUTPUT 'ACTNR LASTNR ISO NWI EC NCA'
124.000 40  N=NORE=NO=NRA=IRESLT=0
125.000 C
126.000 C  DATA DECODING:
127.000 C
128.000 50  NRA=NRA+1
129.000      CALL BUFFER IN(1,1,IBS,150,ISO,NWI,IEC)
130.000      IF(NRA.LT.NRSTART)GO TO 50
131.000      DECODE(600,10,IBS,NC)(CANAL(I),DATA(I),I=1,100)
132.000      IF(LI.LT.1)GO TO 60
133.000      WRITE (102,15)(NRA,NREND,ISO,NWI,IEC,NC)
134.000 60  IF(ISO.NE.2)GO TO 1000
135.000      COUNT=0
136.000 70  COUNT=COUNT+1
137.000      IF(CANAL(COUNT).LE.NRCH)GO TO 90
138.000 80  IF(COUNT.LT.100)GO TO 70
139.000      IF(NRA.LT.NREND)GO TO 50
140.000      GO TO 600
141.000 90  IDON=DATA(COUNT)/1000
142.000      GO TO (101,102,103,104,105,106,107,108,109)IDON
143.000      MARK=0
144.000      VOLT=0
145.000      IDATA=DATA(COUNT)
146.000      GO TO 200
147.000 101 MARK=1
148.000      VOLT=0
149.000      IDATA=DATA(COUNT)-1000
150.000      GO TO 200
151.000 102 MARK=0
152.000      VOLT=-1
153.000      IDATA=DATA(COUNT)-2000
154.000      GO TO 200
155.000 103 MARK=1
156.000      VOLT=1
157.000      IDATA=DATA(COUNT)-3000
158.000 200 RESULT=(IDATA*(-1/1000))+VOLT
159.000      OVERFLO=0
160.000      GO TO 400
161.000 104 MARK=0
162.000      VOLT=0
163.000      IDATA=DATA(COUNT)-4000
164.000      GO TO 300

```

LISTING (L) 1-VI

```
165.000 105 MARK=1
166.000 VOLT=0
167.000 IDATA=DATA(COUNT)-5000
168.000 GO TO 300
169.000 106 MARK=0
170.000 VOLT=1
171.000 IDATA=DATA(COUNT)-6000
172.000 GO TO 300
173.000 107 MARK=1
174.000 VOLT=1
175.000 IDATA=DATA(COUNT)-7000
176.000 300 RESULT=(IDATA*1/1000)+VOLT
177.000 OVERFLO=0
178.000 GO TO 400
179.000 108 MARK=0
180.000 OVERFLO=1
181.000 RESULT=(DATA(COUNT)-8000)/1000
182.000 GO TO 400
183.000 109 MARK=1
184.000 OVERFLO=1
185.000 RESULT=(DATA(COUNT)-9000)/1000
186.000 C
187.000 C OUTPUT:
188.000 C
189.000 400 NO=NO+1
190.000 IRESULT=IRESULT+1
191.000 CANA(NO)=CANAL(COUNT)
192.000 RESULT(NO)=RESULT
193.000 MAR(NO)=MARK
194.000 OVERFL(NO)=OVERFLO
195.000 IF(NO.LT.8)GO TO 80
196.000 N=N+1
197.000 WRITE(3,20)(CANA(NO),RESUL(NO),MAR(NO),OVERFL(NO),NO=1,8)
198.000 NO=0
199.000 GO TO 80
200.000 600 NORE=IRESULT-N*8
201.000 WRITE(3,20)(CANA(NO),RESUL(NO),MAR(NO),OVERFL(NO),NO=1,NORE)
202.000 OUTPUT ' '
203.000 OUTPUT, NRREG
204.000 OUTPUT, IRESULT
205.000 1000 END
```

!SET F:1/NRC5A;IN

!SET F:3 UC;OUT

!FORT4 SANDATA OVER SDB
EXT. FORTRAN IV, VERSION F00
OPTIONS >NS

!RUN SDB

:P: ASSOCIATED.

GROUP16 OF :LIB.:SYS ASSOCIATED FOR BUFFERIN

GROUP17 OF :LIB.:SYS ASSOCIATED FOR 9INPUTL

* * ALLOCATION SUMMARY * *

PROTECTION LOCATION PAGES

DATA (00) A000 4
PROCEDURE (01) AA00 5
DCB (10) A800 1

NUMBER OF FIRST REGISTER=

?1

NUMBER OF LAST REGISTER=

?3

CHECK LIST? YES=1 OR NO=0.

?1

MAX. CHANNEL NUMBER (OCTAL, LESS OR EQUAL 77)

?32

ACTNR	LASTNR	ISO	NWI	EC	NCA																			
1	3	2	150	0	600																			
2	3	2	150	0	600																			
4	.101	0	5	.123	0	6	.083	0	7	.085	0	10	.082	0	11	.091	0	12	.087	0	13	.081	0	0
16	.087	0	20	.082	0	21	.085	0	22	.078	0	23	.087	0	24	.076	0	25	.075	0	26	.085	0	0
27	.082	0	30	.083	0	31	.077	0	32	.080	0	0	.000	0	1	.000	0	2	-.083	0	3	.078	0	0
4	.099	0	5	.122	0	6	.085	0	7	.084	0	10	.083	0	11	.091	0	12	.087	0	13	.080	0	0
14	.086	0	15	.088	0	16	.082	0	17	-.160	0	20	.081	0	21	.080	0	22	.079	0	23	.088	0	0
3	3	2	150	0	600																			
24	.080	0	25	.076	0	26	.085	0	27	.080	0	30	.083	0	31	.076	0	32	.079	0	0	.000	0	1
1	.000	0	2	-.097	0	3	.079	0	4	.099	0	5	.123	0	6	.084	0	7	.083	0	10	.083	0	0
11	.091	0	12	.087	0	13	.081	0	14	.086	0	15	.087	0	16	.085	0	17	-.145	0	20	.082	0	0
21	.082	0	22	.075	0	23	.088	0	24	.075	0	25	.076	0	26	.079	0	27	.082	0	30	.082	0	0
31	.074	0	32	.079	0	0	.000	0	1	.000	0	2	-.222	0	3	.078	0	4	.100	0	5	.124	0	0
6	.084	0	7	.083	0	10	.084	0	11	.092	0	12	.087	0	13	.079	0	14	.086	0	15	.091	0	0
16	.090	0																						

NRREG = 3

IRESLT = 89

STOP 0

Figure 2-VI

UNCLASSIFIED

UNCLASSIFIED

UNCLASSIFIED

LISTING (L) 2-VI

```

1.000 C          ***  SANTEMP  ***
2.000 C
3.000 C  THIS PROGRAM CONVERTS DATA FROM SANDER ADR II (WITH SPECIAL
4.000 C  AMPLIFIER) TO TEMPERATURES MEASURED WITH OMEGA T-TYPE
5.000 C  THERMOCOUPLES. LANGUAGE: XEROX EXTENDED FORTRAN IV.
6.000 C
7.000 C  DATA SOURCE:
8.000 C      DATA FILE PRODUCED WITH PROGRAM "SANDATA".
9.000 C
10.000 C  OUTPUT ON LINE PRINTER/TERMINAL:
11.000 C      SELECTED CHANNEL (HEAD LINE), HEADER, TIME,
12.000 C      AND TEMPERATURES IN 6 COLUMNS.
13.000 C      NUMBER OF RESULTS.
14.000 C
15.000 C  INPUT FROM TERMINAL:
16.000 C      EXAMPLE FOR COMMANDS:
17.000 C          FORT4 SANTEMP OVER STB
18.000 C          SET F:1 /FILENAME;IN
19.000 C          SET F:3 UC;OUT (OUTPUT ON USERS CONSOL)
20.000 C          RUN STB
21.000 C      THEN:
22.000 C          FIRST ENTERED LINE (1 OR ANOTHER)
23.000 C          LAST ENTERED LINE
24.000 C          CHOSEN CHANNEL (DECIMAL OR OCTAL)
25.000 C          FOR ANOTHER RUN ENTER S $
26.000 C
27.000 C
28.000 C  DEFINITIONS:
29.000 C
30.000 C
31.000 C  INPUT FROM TERMINAL:
32.000 C      KF:  FIRST LINE
33.000 C      KL:  LAST LINE
34.000 C      NR:  SELECTED CHANNEL (TEMP.)
35.000 C      NRCH: OCTAL CHANNEL NUMBER (TEMP.)
36.000 C      NOCT: INDICATOR FOR OCTAL NUMBER
37.000 C      NRI:  INTERMEDIATE VALUE
38.000 C      NRJ:  "          "
39.000 C
40.000 C  INPUT FROM DATA FILE:
41.000 C      K,NO:  SUBSCRIPT
42.000 C      J,K:   COUNTER
43.000 C      I,LL:  COUNTER
44.000 C      ML=1:  INDICATES THAT HEADER WAS ALREADY COMPUTED.
45.000 C      N=1:   INDICATES THAT CHANNELS 0, 1 AND 2 HAVE
46.000 C          ALREADY BEEN CONSIDERED.
47.000 C      KCH:   ACTUAL CHANNEL NUMBER
48.000 C      VOLT:  VOLTAGE
49.000 C      MMM:   MANUAL MARK (0 OR 1)
50.000 C      MOL:  VOLTAGE INPUT OVERLOAD (0 OR 1)

```

UNCLASSIFIED

LISTING (L) 2-VI

```

51.000 C      VOLTO:   FIRST 3 DIGITS FOR HEADER
52.000 C      VOLT1:   LAST  "  "  "  "
53.000 C      HEADER:  HEADER
54.000 C      T1,T2:   TIME OF SANDER READING
55.000 C      TABS:    ABSOLUT TIME IN MINUTES STARTING WITH 0
56.000 C      DETI:    TIME DIFFERENCE
57.000 C      TEMP:    TEMPERATURE
58.000 C
59.000 C      OUTPUT:
60.000 C      HEAD:    HEADER
61.000 C      TIM:     TIME
62.000 C      TEM:     TEMPERATURE
63.000 C      IRES:    NUMBER OF RESULTS
64.000 C      NA,NL:   COUNTER
65.000 C
66.000 C
67.000 C      PROGRAM
68.000 C
69.000 C
70.000 C
71.000 C
72.000 C      FORMAT(5X,'TEMPERATURES FOR')
73.000 10     FORMAT(5X,'CHANNEL NR.=',I3,1X)
74.000 20     FORMAT(5X,'CHANNEL OCT.=',I3,1X)
75.000 25     FORMAT(5X,'/HEADER/TIME (MIN)/TEMPERATURE (C)/')
76.000 30     FORMAT(8(2X,I2,F7.3,I2,I2,1X))
77.000 40     FORMAT(6(1X,I6,1X,F6.1,1X,F5.1,1X))
78.000 C
79.000 C
80.000      DIMENSION KCH(8),VOLT(8),MMM(8),MOL(8)
81.000      DIMENSION HEAD(6),TIM(6),TEM(6)
82.000 C
83.000 C
84.000 C
85.000      OUTPUT ' '
86.000      OUTPUT '-----'
87.000      OUTPUT ' '
88.000      OUTPUT ' '
89.000 C      TERMINAL INPUT:
90.000      OUTPUT 'FIRST LINE?'
91.000      INPUT, KF
92.000      OUTPUT 'LAST LINE?'
93.000      INPUT, KL
94.000 100    OUTPUT 'WHAT CHANNEL NUMBER?'
95.000      INPUT, NR
96.000      OUTPUT 'IS IT AN OCTAL NUMBER? YES=1, NO=0.'
97.000      INPUT, NOCT
98.000      IF(NOCT.GT..5)GO TO 150
99.000      IF(NR.GT.62)GO TO 140
100.000     IF(NR.GT.0)GO TO 200

```

LISTING (L) 2-VI

```
101.000 120   OUTPUT 'MIN. CHANNEL NUMBER =1!'  
102.000      GO TO 100  
103.000 140   OUTPUT 'MAX. CHANNEL NUMBER =6!'  
104.000      GO TO 100  
105.000 150   NRI=10*INT(NR/10)  
106.000      NRJ=NR-NRI  
107.000      IF(NRJ.LT.8)GO TO 160  
108.000      OUTPUT 'NUMBER IS NOT OCTAL! ENTER AGAIN!'  
109.000      GO TO 100  
110.000 160   IF(NR.GT.77)GO TO 180  
111.000      IF(NR.LT.3)GO TO 190  
112.000      GO TO 220  
113.000 180   OUTPUT 'MAX. OCTAL CHANNEL NUMBER =77!'  
114.000      OUTPUT ' '  
115.000      GO TO 100  
116.000 190   OUTPUT 'MIN. OCTAL CHANNEL NUMBER =3!'  
117.000      GO TO 100  
118.000 C CHANGE OCTAL TO DECIMAL NUMBERS:  
119.000 200   NRCH=NR+2*INT((NR+2)/8)+2  
120.000      GO TO 300  
121.000 220   NRCH=NR  
122.000      NR=NRCH-2*INT(NRCH/10)-2  
123.000 C OUTPUT HEAD LINE:  
124.000 300   OUTPUT ' '  
125.000      WRITE(3,5)  
126.000      WRITE(3,10) NR  
127.000      WRITE(3,20) NRCH  
128.000      OUTPUT ' '  
129.000      WRITE(3,25)  
130.000      OUTPUT ' '  
131.000 C  
132.000 C DECODING DATA, CALCULATION OF TEMPERATURES:  
133.000 320   L=LL=M=N=0  
134.000      NA=NL=NO=ML=0  
135.000      IRES=0  
136.000      DO 700 I=1,KL  
137.000      DO 350 J=1,8  
138.000      READ(1,30)(KCH(J),VOLT(J),MMM(J),MOL(J), J=1,8)  
139.000 350   CONTINUE  
140.000      IF(I.LT.KF)GO TO 700  
141.000      DO 600 K=1,8  
142.000      IF(N.EQ.1)GO TO 420  
143.000      IF(KCH(K).NE.0)GO TO 360  
144.000      VOLTO=1000000.*VOLT(K)  
145.000      M=1  
146.000      IF(K.GT.5)GO TO 545  
147.000      GO TO 600
```

*

LISTING (L) 2-VI

```
148.000 C HEADER:
149.000 360 IF(KCH(K).NE.1)GO TO 380
150.000 IF(M.EQ.1)GO TO 370
151.000 VOLT0=0.
152.000 370 VOLT1=1000.*VOLT(K)+0.5
153.000 HEADER=VOLT0+VOLT1
154.000 ML=1
155.000 GO TO 500
156.000 C TIME:
157.000 380 IF(KCH(K).NE.2)GO TO 420
158.000 IF(ML.EQ.1)GO TO 400
159.000 HEADER=0.
160.000 GO TO 500
161.000 400 IF(LL.GT.0)GO TO 402
162.000 T2=VOLT(K)
163.000 LL=1
164.000 T1=T2
165.000 TABS=0.
166.000 GO TO 520
167.000 402 T2=VOLT(K)
168.000 IF((T2.GT.0).AND.(T1.GE.0))GO TO 406
169.000 IF((T2.LT.0).AND.(T1.LE.0))GO TO 406
170.000 IF((T2.GE.0).AND.(T1.LT.0))GO TO 404
171.000 IF((T2.EQ.0).AND.(T1.EQ.0))GO TO 408
172.000 DETI=1.600-T2-T1
173.000 GO TO 410
174.000 404 DETI=2.000+T2+T1
175.000 GO TO 410
176.000 406 DETI=SIGNF(T2-T1)
177.000 GO TO 410
178.000 408 DETI=3.600
179.000 410 TABS=TABS+1000.*DETI/60.
180.000 T1=T2
181.000 GO TO 520
182.000 C TEMPERATURE:
183.000 420 IF(KCH(K).NE.NRCH)GO TO 545
184.000 IF(N.NE.1)GO TO 600
185.000 ML=0
186.000 IF(MOL(K).LT.1)GO TO 440
187.000 TEMP=999.9
188.000 N=0
189.000 GO TO 540
190.000 440 IF((VOLT(K).LE.0.330).AND.(VOLT(K).GE.-0.180))GO TO 460
191.000 TEMP=999.9
192.000 N=0
193.000 GO TO 540
194.000 460 IF(VOLT(K).LT.0)GO TO 480
195.000 TEMP=256.6*VOLT(K)-5.4*VOLT(K)**2
196.000 TEMP=TEMP+3.6
197.000 N=0
198.000 GO TO 540
```

LISTING (L) 2-VI

```
199.000 480    TEMP=257.3*VOLT(K)-5.4*VOLT(K)**2+2.75*VOLT(K)**3
200.000        TEMP=TEMP+3.6+(TEMP**3)/9000.+(TEMP**4)/600000.
201.000        N=0
202.000        GO TO 540
203.000 C OUTPUT:
204.000 500    NO=NO+1
205.000        HEAD(NO)=HEADER
206.000        NO=NO-1
207.000        IF(K.GT.6)GO TO 545
208.000        IF(ML.EQ.1)GO TO 600
209.000        GO TO 400
210.000 520    NO=NO+1
211.000        TIM(NO)=TABS
212.000        N=1
213.000        GO TO 560
214.000 540    NO=NO+1
215.000        TEM(NO)=TEMP
216.000        IRES=IRES+1
217.000 545    IF(I.EQ.KL)GO TO 550
218.000        IF(NO.LT.6)GO TO 600
219.000        WRITE(3,40)(HEAD(NO),TIM(NO),TEM(NO),NO=1,6)
220.000        NO=0
221.000        NL=NL+1
222.000        GO TO 600
223.000 550    IF(K.LT.8)GO TO 600
224.000        NA=IRES-NL*6
225.000        WRITE(3,40)(HEAD(NO),TIM(NO),TEM(NO),NO=1,NA)
226.000        NO=0
227.000        OUTPUT ' '
228.000        GO TO 800
229.000 560    NO=NO-1
230.000 600    CONTINUE
231.000 700    CONTINUE
232.000 800    OUTPUT, IRES
233.000        OUTPUT ' '
234.000        END
```

*

Figure 4-VI

006A: WEBSTER,380W 09/14/78 18:01
 NRC COLD CHAMBER TEST 8/1978
 FILE MTW5
 TEST # 5 , LINE 1 TO 1130.

TEMPERATURES FOR
 CHANNEL NR.= 2
 CHANNEL OCT.= 4

/HEADER/TIME (MIN)/		TEMPERATURE (C)/										
53000	.0	24.6	53000 .2	24.9	53000 .3	25.1	53001 .5	25.9	53001 .7	24.9	53001 .8	24.9
53001	1.0	25.4	53001 1.2	25.6	53001 1.3	24.9	56002 1.5	25.6	56006 6.0	25.4	57011 11.0	24.6
57021	21.0	24.3	57031 31.0	25.1	57041 41.0	23.8	57051 51.0	24.3	57061 61.0	24.3	57071 71.0	23.3
57071	81.0	24.1	57071 91.0	23.3	57071 101.0	22.6	57071 111.0	23.6	57071 121.0	22.8	57071 131.0	23.3
57071	141.0	21.5	57141 151.0	23.1	57141 161.0	22.0	57141 171.0	22.3	57141 181.0	21.5	57131 191.0	20.5
57131	201.0	21.5	57131 211.0	21.3	57131 221.0	20.3	57131 231.0	20.8	57131 241.0	19.7	57131 251.0	20.0
57254	261.0	18.7	57254 271.0	19.7	57254 281.0	19.2	57254 291.0	18.2	57254 301.0	18.0	57254 311.0	18.5
57314	321.0	16.9	57314 331.0	17.4	57314 341.0	17.7	57314 351.0	17.7	57314 361.0	17.7	57370 371.0	17.2
57370	381.0	16.4	57370 391.0	15.1	57370 401.0	16.2	57370 411.0	15.9	57370 421.0	16.2	57370 431.0	15.1
57434	441.0	14.4	57434 451.0	14.6	57434 461.0	15.4	57434 471.0	13.9	57434 481.0	13.9	57490 491.0	13.3
57490	501.0	14.4	57490 511.0	12.3	57490 521.0	13.3	57490 531.0	13.1	57490 541.0	13.1	57556 551.0	13.1
57556	561.0	11.8	57556 571.0	12.3	57556 581.0	11.8	57556 591.0	10.8	57556 601.0	10.3	57556 611.0	10.5
57556	621.0	10.0	57626 631.0	10.8	57626 641.0	10.8	57626 651.0	10.3	57626 661.0	10.5	57626 671.0	10.3
57679	681.0	10.3	57679 691.0	10.0	57679 701.0	10.3	57679 711.0	9.8	57679 721.0	8.5	57679 731.0	8.2
57736	741.0	8.5	57736 751.0	8.0	57736 761.0	7.7	57736 771.0	6.9	57736 781.0	7.4	57736 791.0	7.7
57799	801.0	7.7	57799 811.0	6.7	57799 821.0	7.4	57799 831.0	8.0	57799 841.0	6.7	57799 851.0	6.2
57856	861.0	6.2	57856 871.0	5.4	57856 881.0	5.4	57856 891.0	5.1	57856 901.0	5.7	57856 911.0	5.9
57918	921.0	6.2	57918 931.0	5.7	57918 941.0	5.1	57918 951.0	4.6	57918 961.0	4.4	57918 971.0	3.9
57918	981.0	3.9	57918 991.0	3.9	57918 1001.0	4.4	57918 1011.0	4.4	57918 1021.0	3.1	57003 1031.0	3.9
57003	1041.0	3.3	57003 1051.0	3.6	57003 1061.0	3.1	57003 1071.0	3.6	57003 1081.0	2.8	57091 1091.0	2.6
57091	1101.0	2.8	57091 1111.0	2.8	57091 1121.0	2.6	57091 1131.0	3.1	57091 1141.0	2.6	57091 1151.0	2.8
57091	1161.0	1.5	57176 1171.0	2.6	57176 1181.0	2.8	57176 1191.0	1.8	57176 1201.0	1.0	57176 1211.0	1.3
57176	1221.0	2.1	57176 1231.0	2.6	57176 1241.0	2.1	57176 1251.0	.8	57176 1261.0	1.3	57268 1271.0	2.1
57268	1281.0	1.8	57268 1291.0	1.3	57268 1301.0	-.0	57268 1311.0	1.3	57268 1321.0	.8	57330 1331.0	1.5
57330	1341.0	.8	57330 1351.0	.3	57330 1361.0	.3	57330 1371.0	-.3	57330 1381.0	-.3	57390 1391.0	.3
57390	1401.0	-.8	57390 1411.0	-.3	57390 1421.0	.8	57390 1431.0	-.8	57390 1441.0	-1.3	57450 1451.0	-1.0
57450	1461.0	-1.0	57450 1471.0	-.3	57450 1481.0	-.5	57450 1491.0	-1.0	57450 1501.0	-1.0	57450 1511.0	-2.1
57515	1521.0	-.8	57515 1531.0	-.8	57515 1541.0	-.0	57515 1551.0	-1.0	57515 1561.0	-1.8	57515 1571.0	-1.0
57572	1581.0	-1.6	57572 1591.0	-1.0	57572 1601.0	-2.1	57572 1611.0	-1.8	57572 1621.0	-2.6	57630 1631.0	-2.1
57630	1641.0	-1.0	57630 1651.0	-1.8	57630 1661.0	-1.3	57630 1671.0	-1.3	57630 1681.0	-2.1	57630 1691.0	-1.6
57695	1701.0	-2.1	57695 1711.0	-2.6	57695 1721.0	-2.6	57695 1731.0	-2.3	57695 1741.0	-3.4	57695 1751.0	-3.4
57745	1761.0	-2.1	57745 1771.0	-2.9	57745 1781.0	-2.3	57745 1791.0	-2.3	57745 1801.0	-2.9	57745 1811.0	-2.3
57815	1821.0	-3.1	57815 1831.0	-2.3	57815 1841.0	-2.3	57815 1851.0	-3.1	57815 1861.0	-3.1	57815 1871.0	-3.9
57815	1881.0	-3.9	57890 1891.0	-3.1	57890 1901.0	-4.2	57890 1911.0	-3.1	57890 1921.0	-3.1	57890 1931.0	-3.9
57890	1941.0	-3.6	57942 1951.0	-4.4	57942 1961.0	-4.4	57942 1971.0	-3.4	57942 1981.0	-3.9	57942 1991.0	-4.7
57942	2001.0	-4.7	57942 2011.0	-4.2	57942 2021.0	-5.0	57942 2031.0	-5.0	57942 2041.0	-5.5	57942 2051.0	-3.6
57942	2061.0	-5.0	57070 2071.0	-4.2	57070 2081.0	-5.0	57070 2091.0	-5.0	57070 2101.0	-5.7	57070 2111.0	-5.5

UNCLASSIFIED

UNCLASSIFIED

APPENDIX VII

BATTERY INSULATION AND HEATING

The temperature plots (Figure 6 to Figure 16)* indicate that the insulated batteries cool at a rate of about $1.5^{\circ}\text{C}/\text{h}$ at a 20°C temperature difference between the battery and the ambient. For the non-insulated batteries the cooling rate is about $2^{\circ}\text{C}/\text{h}$ (see ref. 19**). In comparison to the APC tests the cooling rates for normal truck batteries without any insulation or partial insulation is $3.2^{\circ}\text{C}/\text{h}$ to $4.2^{\circ}\text{C}/\text{h}$ at 20°C temperature difference (see ref. 20***). The differences in rates are caused by different heat capacities of the batteries, the location of the battery and insulation of the battery casing. Figure 1-VII shows the general temperature behaviour of a battery. The battery capacity is considerably decreased by low temperatures and high currents.

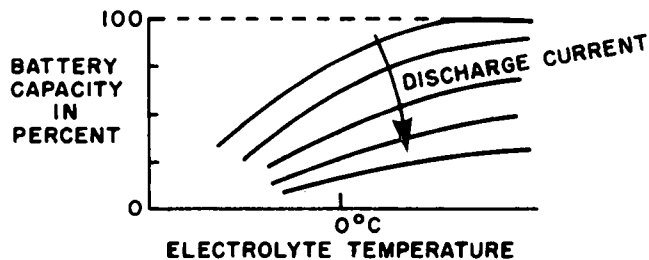

That means: if the batteries are kept warm enough, battery loss due to temperature drop can become acceptable.

Fig. 1-VII: Battery capacity as a function of temperature and discharge current from [1]†.

-
- * Temperature plots 1 to 8, unheated battery.
 - ** Alert report.
 - *** NRC-LETE report.
 - † Inductive Heating of Starter Batteries, VARTA Company Ltd, Hannover, W-Germany 1970.

To prevent a battery from cooling two methods can be applied: Heating and Insulation, i.e. increase the heat content and decrease the heat transfer.

Insulation of a battery means that heat produced by the battery itself is stored for a longer time. The heat is a result of ohmic heating and chemical reactions during discharge and charge. Therefore heat transfer to the battery cannot be avoided. But heat transfer from the battery to the environment can be slowed by insulation and the loss in both battery energy capacity and charging capability (Figure 2-VII) reduced. The battery cables were disconnected by switches for each test to stop heat transfer through them to the vehicle hull.

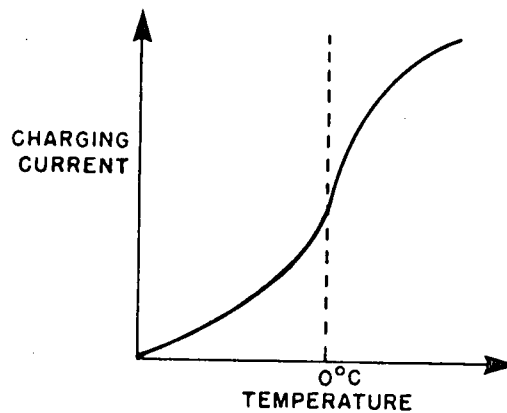

Fig. 2-VII: Charging current as a function of temperature. Voltage is constant. From [1].

In addition to insulation heating was applied. Temperature plots Figure 14* to Figure 16* show the battery cooling curves for auxillary heating when 37mm of medium density polystrene foam was used for battery compartment insulation. For test of 10, Figure 15, 7.0 hours of (12 volt) 80 watt resistive wire heating were required to maintain the battery temperature at -15°C for an ambient temperature of -25°C over a 24 hour period.

* Temperature plot for tests, # 9 to 11.

APPENDIX VIII

DISCUSSION OF VOLTAGE LINE METHOD FROM REFERENCE 19

The following has been included to describe the voltage line method that determined when starting occurred for the tests of reference 19. The essential differences between the treatment of data for this report and the data of reference 19 lie in the determination of RPM. Reference 19 calculated an average RPM between two pressure pulses on either side of the voltage line. This report used an analog RPM that was updated at a frequency of 72 X cranking frequency. The description from reference 19 is as follows:

"By attempting to perform the above procedures on all tests it was clear that difficulty existed in defining vehicle starting. The airflow signal seemed to lag the pressure signal indications of rpm as a result of the airflow transducer turbine inertia and the fact that the transducer was upstream of the combustion process. Consequently it was not used for anything more than an estimation of vehicle starting. It was noticed however, that if a line was drawn vertically through each transducer signal at the time just before the starter voltage smoothed, reasonable results could be obtained consistent with stall rpm. The smoothed starter voltage signal indicated the starter motor was no longer needed to drive the engine even though it was providing some assistance since the starter gear was engaged with the flywheel. It was found that by gradually stalling the engine with a fuel cut-off valve, the marginal stall rpm was shown to be between 200 and 300 rpm. The rpm was physically measured by obtaining the distance between the two pressure pulses on either side of the voltage line. By using this procedure it was found that a high pressure reading usually occurred just

before the line followed by a pressure decrease. Following this argument the question of basing the starting on pressure rather than voltage of the starter arises. The answer is significantly more consistent results were achieved for these tests using the voltage line method."

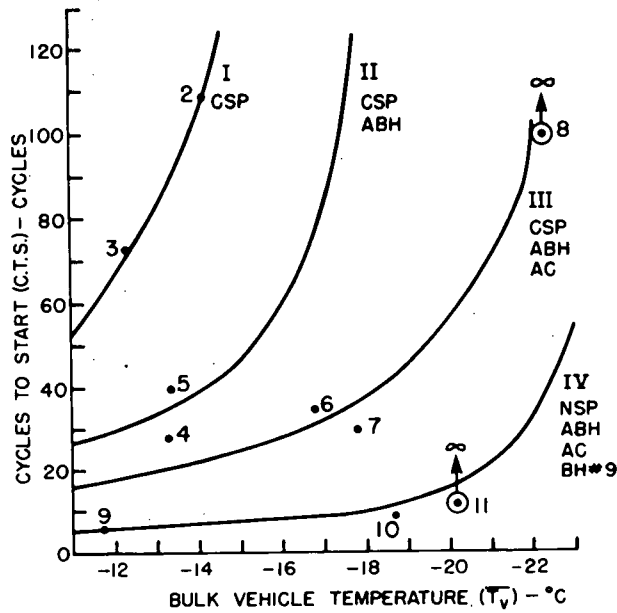

FIGURE 3

Fig. 1-VIII: The number of cycles to start is shown as a function of vehicle bulk temperature.

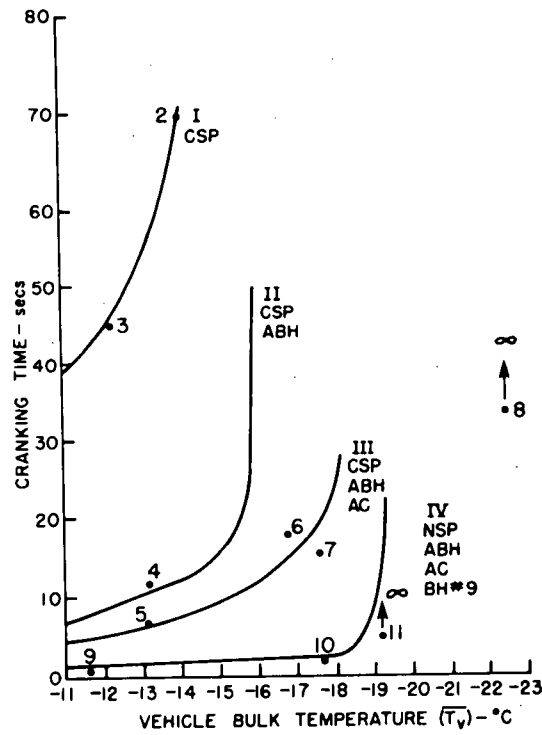

Fig. 2-VIII: The cranking time in seconds is shown as a function of vehicle bulk temperature.

APPENDIX IX

FUEL ANALYSIS

A sample of Arctic Grade diesel fuel used for the summer cold chamber tests was sent to the National Research Council (NRC), Fluids and Lubricants Laboratory, following the December 1978 cold chamber tests (under the supervision of Mr. G.J. Hutton) carried out by Brossard and Gallop (22). The results of this analysis are shown in Table 1-IX.

TABLE 1-IX

	<u>Method</u>	<u>FLO-79201 Diesel Fuel</u>	
Distillation:			
Initial Boiling Point °F	D86	333°F	167°C
10% Recovered, °F		373	189
50% Recovered, °F		437	225
90% Recovered, °F		545	285
Final Boiling Point, °F		621	327
Recovery, % Vol.		98.2	
Residue, % Vol.		1.6	
Loss, % Vol.		0.2	
Kinematic Viscosity at 40°C, cSt	D445	1.75	
Cloud Point, °F	D2500	-8	
API Gravity at 60°F	D287	40.7	
Specific Gravity at 60/60°F	D287	0.8217	
Cetane Index	D976	48.0	
Freezing Point, °C(°F)	D2386	-18.0 (-0.4)	

The above results must be compared with the present standard to ascertain whether or not the fuel was within the specification limits.

Table 2-IX describes the Canadian Specifications Board, Standard for Diesel Fuel 3-GP-6M, (23), type AA, A, B, C and D. The low temperature fuel is type AA.

TABLE 2-IX

	Type AA	Type A	Type B	Type C	Type D	Method Méthode ASTM
Density, kg/L at 15°C	Report Indiquer	Report Indiquer	Report Indiquer	Report Indiquer	Report Indiquer	D 1298
Flash Point, °C, min.	40	40	40	40	40	D 93
Freezing Point, °C, max.	-48.5	—	—	—	—	D 2386
Cloud Point, °C, max.	—	-34	-23	-18	0	D 2500
Pour Point, °C, max.	-51	-39	-30	-24	-6	D 97 ^a
Kinematic Viscosity 40°C, mm ² /s (cSt) ^a min.	1.2	1.4	1.7	1.8	2.0	D 445
max.	2.4	3.4	4.1	4.1	4.1	
Kinematic Viscosity at -35°C, mm ² /s (cSt) ^a	Report Indiquer	—	—	—	—	D 445
Distillation:						
50% recovered, °C	Report Indiquer	Report Indiquer	Report Indiquer	Report Indiquer	Report Indiquer	D 86
90% recovered, °C, max.	290	316	330	343	343	
End Point, °C, max.	300	343	371	371	371	
Water and Sediment, % vol., max.	0.01	0.01	0.05	0.05	0.05	D 1796 ²
Total Acid Number, max.	0.10	0.10	0.10	0.10	0.10	D 974
Strong Acid Number, max.	nil néant	nil néant	nil néant	nil néant	nil néant	D 974
Strong Base Number, max.	nil néant	nil néant	nil néant	nil néant	nil néant	D 974
Sulphur, % mass, max.	0.2	0.5	1.0	1.0	1.0	D 1552
Corrosion, 3 h at 100°C, max.	No./N ^o 1	No./N ^o 1	No./N ^o 1	No./N ^o 1	No./N ^o 1	D 130
Carbon Residue (Ramsbottom), on 10% bottoms, % mass, max. ³	0.10	0.20	0.20	0.20	0.20	D 524
Ash, % mass, max.	0.005	0.01	0.01	0.01	0.01	D 482
Ignition Quality, Cetane No., min. ⁴ , or	40	40	40	47 ⁵	45	D 613
Cetane Index, min. ⁴	40	40	40	50 ⁶	45	D 976

UNCLASSIFIED

In Table 3-IX the DREO sample is compared with another group of samples all of which are supposedly representative of Type AA diesel fuel. The fuels are compared in terms of Cetane # and boiling point distillation temperatures. One can see that the DREO sample is within the limits of the fuels tested for the 10% temperatures. This value or the 5% temperature is generally considered a more meaningful value than the initial boiling point temperatures. Comparatively, the volatility of the DREO sample appears to be acceptable.

It is noteworthy to point out that the 3-GP-6M standard does not describe how well an engine will start using a type AA fuel. It is true that by having a freezing point of -48.5°C maximum and having a cetane number of 40 minimum, a partial indication is present. However, the volatility is the other parameter that must be acceptable before successful starting will occur. Only the 90% and 100% temperature limits are specified. For a complete story of cold starting capability at least the 10% limit should be specified.

From Table 1-IX a freezing point of -18°C indicates the presence of condensed water in the fuel. It is this water that is believed to have somehow reduced the cold starting capability. Just how this has been accomplished is not yet known. Recommendations have been made that a short low temperature study be conducted with an injector test stand using Type AA fuels with varying amounts of condensed water present.

UNCLASSIFIED

TABLE 3-IX

	DREO Sample (NRC)		Jet A (NRC)		Type AA (Gulf Edmonton)		Type AA (NRC Sample)		Fuel Spec 3-GP-6M		3-GP-6M Type AA (QETE) Sample Tested (Representative of Spec)	
	°F	°C	°F	°C	°F	°C	°F	°C	°F	°C	°F	°C
Initial B.P.	333	167	343	172	326	163	325	163	-	-	398	203
10% B.P.	373	189	374	190	365	185	371	188	-	-	417	213
20% B.P.	-	-	387	197	375	190	-	-	-	-	423	217
50% B.P.	437	225	416	213	412	211	425	218	-	-	-	-
90% B.P.	545	285	473	245	475	246	518	270	554	290	-	-
100% B.P.	621	327	513	267	594	284	586	307	572	300	523	273
Cetane Index	48		-		-		44.5		40		-	
API	40.7		-		-		-		-		-	

UNCLASSIFIED

UNCLASSIFIED

Lubrication Oil Code Breakdown for Figure 24, 25, and 26.

#10 - SAE No. 10

S₁ - Synthetic DN600 (Polar Start - Fina)

S₂ - Synthetic (Energy Frigid Go)

S_x - Non-Specified Synthetic

UNCLASSIFIED

APPENDIX X

U.S. TESTS

The following Table 1-X has been taken from reference (21) and the related cranking times are plotted for Figure 19. The average rpm was used to calculate the cycles to start for Figure 18.

UNCLASSIFIED

TABLE 1-X
U.S. DATA

Run No.	1	2	3	4	5	6	7	8	9	10	11	12	13
Fuel	DF2	DF2	DF2	DF2	DF2	DFA	DFA	DFA	DFA	DFA	DFA	DFA	DFA
Oil	OE10	OE10	OE10	OE10	OE10	OE10	OE10	OE10	OE10	OES	OES	OES	OES
Average Soak Temp., °F	40	25	15	0	0	-10	-10	-10	-10	-10	-27	-26	-26
<u>Temp. Before Attempt, °F</u>													
(1) Ambient Air	35	25	16	-4	-1	-10	-10	-9	-13	-12	-27	-26	-26
(2) Oil in Sump	39	25	16	0	1	-10	-10	-9	-12	-10	-27	-26	-24
(3) Fuel to Injectors	37	25	16	0	1	-10	-10	-9	-12	-11	-27	-26	-26
(4) Battery Electrolyte A	-	24	15	-3	1	-11	-13	-12	-16	-16	-31	-27	-27
(5) Battery Electrolyte B	41	27	17	1	2	-8	-6	-5	-10	-8	-24	-23	-24
Cold Soak Time, Hrs.	15	18	10½	9	11	9	11½	10	12½	10	7½	13	11
Battery Specific Gravity	1.240	1.273	1.280	1.278	1.278	1.271	1.284	1.259	1.279	1.264	1.263	1.263	1.273
Average Voltage Battery Before Cranking	25.2	25.4	25.4	25.2	25.5	25.2	25.6	25.9	25.3	26.0	25.3	25.2	25.4
Battery A While Cranking	20.4	19.3	19.0	17.2	16.8	14.5	14.9	14.9	14.8	17.9	13.8	14.5	14.8
Starter Voltage While Cranking	17.0	16.2	15.5	14.0	11.6	10.8	10.2	11.0	11.0	15.0	10.5	10.8	11.3
Cranking Current, Amp. (Initial Surge)	765	-	755	945	930	900	780	960	-	855	810	720	750
Average While Cranking, Amp.	343	-	420	495	495	600	525	570	-	405	525	480	510
Average Crank Speed, RPM	194	191	134	104	115	85	97	154	143	155	86	92	94
<u>Cranking Times, Sec.</u>													
Defueled Pre crank	4:4	-	4.4	7.9	4.3	5.8	1.6	6.5	3.8	6.6	3.9	6.2	4.3
To First Fire	0.1	-	2.3	2.0	6.8	2.7	DNF	3.1	2.7	0.8	3.4	2.4	2.4
To Start	0.9	-	8.9	14.4	13.7	DNS	DNS	33.7	39.4	32.1	47.4	DNS	51.2
Air Box Heater Time	-	-	6.2	11.0	7.6	-	-	22.3	32.0	14.3	34.8	-	26.2
% Time ABH Used	-	-	89.0	79.6	55.5	-	-	66.2	81.2	44.5	73.9	-	51.2

UNCLASSIFIED

APPENDIX XI

DECEMBER TESTS

The following Table I-XI has been taken from reference (23) and its cranking times are plotted for Figure 25. The average rpm was used to calculate the cycles to start for Figure 24.

TABLE I-XI

Experiment Number	Bulk Temp. (°C)	Initial Battery Temp. (°C)	Cranking Time to Obtain a Start (S)	Peak Current (A)	30s TV (V)	30s Cranking Current (A)	50-60S R.P.M.	Capacity Required to Start (Ah)
1*	-20	-15	117	625	16.4	450	136	12.9
2*	-20	-15	115	642	17.25	450	146	13.2
3*	-20	-15	115	655	17.3	458	146	13.0
4*	-22	-15	No-start	697	17.2	472	138	
	-22	(1)	113	600	19.6	445	173	12.6
- 5*	-20	-16.5	No-start	677	17.2	460	145	
	-20	(1)	91	562	-	430	183	8.7
6**	-20	-16	176	598	17.5	425	159	18.9
7**	-18	-15	94	580	18.2	420	170	10.2
8**	-21	-15.5	195	610	17.8	430	158	21.3
9**	-26	(1)	No-start	665	18.4	430	168	-

* Oil "A" - DN 600 Polar Start

** Oil "B" - Emery Frigid Go

(1) A.P.C. Batteries + Slaves

UNCLASSIFIED

UNCLASSIFIED

DOCUMENT CONTROL DATA - R & D		
(Security classification of title, body of abstract and indexing annotation must be entered when the overall document is classified)		
1. ORIGINATING ACTIVITY Defence Research Establishment Ottawa Shirley Bay, Ottawa, Ontario K1A 0Z4		2a. DOCUMENT SECURITY CLASSIFICATION Unclassified
		2b. GROUP
3. DOCUMENT TITLE The Low Temperature Chamber Testing of the Compression Ignition Engine and System of the Armoured Personnel Carrier (APC) M113A1 (U)		
4. DESCRIPTIVE NOTES (Type of report and inclusive dates) Technical Note No. 80-26		
5. AUTHOR(S) (Last name, first name, middle initial) G.D. Webster, R.G. Glass and G.J. Hutton		
6. DOCUMENT DATE JUNE 1981	7a. TOTAL NO. OF PAGES 108	7b. NO. OF REFS 24
8a. PROJECT OR GRANT NO. 25B00	9a. ORIGINATOR'S DOCUMENT NUMBER(S) DREO TN 80-26	
8b. CONTRACT NO.	9b. OTHER DOCUMENT NO.(S) (Any other numbers that may be assigned this document)	
10. DISTRIBUTION STATEMENT UNLIMITED DISTRIBUTION		
11. SUPPLEMENTARY NOTES		12. SPONSORING ACTIVITY DREO
13. ABSTRACT - Unclassified A study has been undertaken to validate and supplement data observed during the February 1978, Alert (NWT) low temperature starting tests for the Canadian Forces Armoured Personnel Carrier M113A1. The cold chamber testing found the M113A1 compression ignition (CI) GMC6V53 engine to have a somewhat reduced starting capability than was observed for the Arctic testing. The "No-Start Temperature-T _{NS} " using #10 oil and type AA fuel for the tests of this study was $T_{NS} \approx -20^{\circ}\text{C}$ ($T_{NS} \approx -22^{\circ}\text{C}$ for the Arctic Tests). It is believed that traces of water vapour in the fuel may have contributed to this discrepancy. The T _{NS} for the Arctic grade synthetic oil DN 600 and Type AA fuel was $T_{NS} \approx -22^{\circ}\text{C}$. The report describes in detail the systems used for instrumentation, experimentation and data analysis. This detail has been provided to assist those that wish to continue the work of this study. A number of conclusions have been drawn and recommendations made for areas of required future effort. The report is concluded with an overall general discussion that summarizes and suggests an approach to improve the cold starting capability of CF compression ignition combat vehicle powerplants.		

KEY WORDS

Low Temperature Starting Tests
 Arctic
 Cold
 Trucks
 Combat Vehicle
 Armoured Personnel Carrier
 Diesel Engines
 Compression Ignition
 Cold Chamber
 Cold Cranking
 2 Stroke
 Direct Injection
 GMC6V53

INSTRUCTIONS

1. ORIGINATING ACTIVITY: Enter the name and address of the organization issuing the document.
- 2a. DOCUMENT SECURITY CLASSIFICATION: Enter the overall security classification of the document including special warning terms whenever applicable.
- 2b. GROUP: Enter security reclassification group number. The three groups are defined in Appendix 'M' of the DRB Security Regulations.
3. DOCUMENT TITLE: Enter the complete document title in all capital letters. Titles in all cases should be unclassified. If a sufficiently descriptive title cannot be selected without classification, show title classification with the usual one-capital-letter abbreviation in parentheses immediately following the title.
4. DESCRIPTIVE NOTES: Enter the category of document, e.g. technical report, technical note or technical letter. If appropriate, enter the type of document, e.g. interim, progress, summary, annual or final. Give the inclusive dates when a specific reporting period is covered.
5. AUTHOR(S): Enter the name(s) of author(s) as shown on or in the document. Enter last name, first name, middle initial. If military, show rank. The name of the principal author is an absolute minimum requirement.
6. DOCUMENT DATE: Enter the date (month, year) of Establishment approval for publication of the document.
- 7a. TOTAL NUMBER OF PAGES: The total page count should follow normal pagination procedures, i.e., enter the number of pages containing information.
- 7b. NUMBER OF REFERENCES: Enter the total number of references cited in the document.
- 8a. PROJECT OR GRANT NUMBER: If appropriate, enter the applicable research and development project or grant number under which the document was written.
- 8b. CONTRACT NUMBER: If appropriate, enter the applicable number under which the document was written.
- 9a. ORIGINATOR'S DOCUMENT NUMBER(S): Enter the official document number by which the document will be identified and controlled by the originating activity. This number must be unique to this document.
- 9b. OTHER DOCUMENT NUMBER(S): If the document has been assigned any other document numbers (either by the originator or by the sponsor), also enter this number(s).
10. DISTRIBUTION STATEMENT: Enter any limitations on further dissemination of the document, other than those imposed by security classification, using standard statements such as:
 - (1) "Qualified requesters may obtain copies of this document from their defence documentation center."
 - (2) "Announcement and dissemination of this document is not authorized without prior approval from originating activity."
11. SUPPLEMENTARY NOTES: Use for additional explanatory notes.
12. SPONSORING ACTIVITY: Enter the name of the departmental project office or laboratory sponsoring the research and development. Include address.
13. ABSTRACT: Enter an abstract giving a brief and factual summary of the document, even though it may also appear elsewhere in the body of the document itself. It is highly desirable that the abstract of classified documents be unclassified. Each paragraph of the abstract shall end with an indication of the security classification of the information in the paragraph (unless the document itself is unclassified) represented as (TS), (S), (C), (R), or (U).

The length of the abstract should be limited to 20 single-spaced standard typewritten lines; 7½ inches long.
14. KEY WORDS: Key words are technically meaningful terms or short phrases that characterize a document and could be helpful in cataloging the document. Key words should be selected so that no security classification is required. Identifiers, such as equipment model designation, trade name, military project code name, geographic location, may be used as key words but will be followed by an indication of technical context.