



PSPC National CADD Standard

Annex E: Toolkit for Revit

Version: 2024

PSPC National CADD Standard - Annex E: Toolkit for Revit

- 1. Introduction 1
- 1.1 Inquiries 1
- 2. PSPC Revit Template 2
- 2.1 Download the PSPC Revit Template 2
- 2.2 Overview of the PSPC Revit Template 2
- 2.3 Project Parameters 4
- 2.4 Shared Parameters 4
- 2.5 Units 4
- 2.6 Project Browser 4
- 2.7 Using Views 4
- 2.8 Starting View 5
- 2.9 Object Styles 5
- 2.10 Phases – Graphics Overrides 5
- 3. PSPC Revit Library 6
- 3.1 Download the PSPC Revit Library 6
- 3.2 Library overview 6
- 4. Revit DWG Export procedure 8
- 4.1 Important usage information 8
- 4.2 DWG Export procedure 8

1. Introduction

The purpose of this document is to provide information and specialised tools with the goal of facilitating the adoption and use of the PSPC National CADD Standard on projects.

The tools listed in this document are intended to be used by internal employees and external consultants working on PSPC projects.

The Toolkit for Revit contains 3 tools:

- The PSPC Revit Template serves as the starting point for projects.
- The PSPC Revit Library provide users with a collection of commonly used families and family types from past projects.
- The Revit DWG Export Procedure streamlines the process of exporting sheets to a format that is compliant with the PSPC National CADD Standard.

1.1 Inquiries

For questions or further information pertaining to this document, please contact the Geomatic Services National Centre of Expertise by email at CADD-CDAO@pwgsc-tpsgc.gc.ca.

For any questions pertaining to the use of the National CADD Standard on a project, please email the regional contact listed in Table 1-1.

Table 1-1 - Regional contact list

Regions	Contact
Atlantic	PWGSC.AtlanticCADD-CDAOAtlantique.TPSGC@pwgsc-tpsgc.gc.ca
Québec	TPSGC.rqcdao-qrcadd.PWGSC@tpsgc-pwgsc.gc.ca
National Capital Area	TPSGC.CDAO-CADD.PWGSC@tpsgc-pwgsc.gc.ca
Ontario	PWGSC.OntCADD-CDAO.TPSGC@pwgsc-tpsgc.gc.ca
Western	PWGSC.WRSIM-ROGIS.TPSGC@pwgsc-tpsgc.gc.ca
Pacific	Walter.Casol@tpsgc-pwgsc.gc.ca

2. PSPC Revit Template

The PSPC Revit Template is a RTE file that serves as the starting point for new projects and is based on the PSPC National CADD Standard. This section explains the download and configuration procedure along with an overview of its content.

2.1 Download the PSPC Revit Template

Open this link to download the template. Save / move the PSPC Revit Template 2023.rte to a familiar location.

- [PSPC Revit Template 2023.rte](#)

2.2 Overview of the PSPC Revit Template

The PSPC Revit Template comes with basic pre-configured families and family types that are based on the PSPC National CADD Standard. This section gives an overview of the content of the template.

2.2.1 Text

Table 2-1 : Text family types

Family Type Name	Description
Arial Narrow_2.5mm	2.5mm text for notes, dimensions, etc.
Arial Narrow_3.5mm	3.5mm text for subheadings
Arial_5.0mm	5.0 mm text for major headings

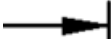
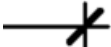
2.2.2 Dimensions

Table 2-2 : Dimension family types

Family Type Name	Description
Architectural	Architectural formatted dimension with arrowheads for dimension terminators.
Engineering	Engineering formatted dimension with ticks for dimension terminators.

2.2.3 Arrows

Table 2-3 : Arrow family types

Family Type Name	Description
Closed Filled	
Architectural Tick	

2.2.4 Line Styles

Table 2-4 : Line Styles

Category	Line Weight	Line Pattern
Extra Thin Lines	1	Solid
Thin Lines	3	Solid
Fine Lines	5	Solid
Medium Lines	7	Solid
Wide Lines	10	Solid
Thick Lines	12	Solid
Extra Thick lines	13	Solid
Beyond	5	Dashed
Centerline	1	Center
Demolished	5	Dashed
Hidden	5	Hidden
Overhead	5	Dashed

2.2.5 Line Weights

Table 2-5 : Line weights

ID	Pen Size
1	0.10 mm
2	0.13 mm

ID	Pen Size
3	0.15 mm
4	0.18 mm

ID	Pen Size
5	0.20 mm
6	0.25 mm



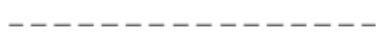

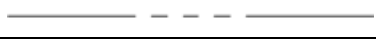

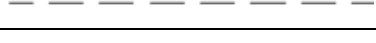
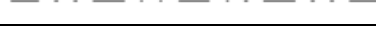
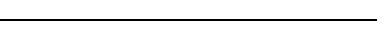
ID	Pen Size
7	0.30 mm
8	0.35 mm
9	0.40 mm
10	0.50 mm

ID	Pen Size
11	0.60 mm
12	0.70 mm
13	1.00 mm
14	1.25 mm

ID	Pen Size
15	1.50 mm
16	2.00 mm



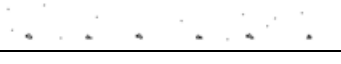


2.2.6 Line Patterns




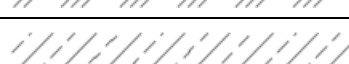

Table 2-6 : Line Patterns

Name	Description
Center	
Center2	
Hidden	
Hidden2	
Phantom	
Phantom2	
Dashed	
Divide	
Dot	

2.2.7 Drafting Pattern

Table 2-7 : Drafting Patterns

Name	Pattern
Concrete 1	
Concrete 2	
Concrete 3	
Crosshatch 1	
Crosshatch 2	

Name	Pattern
Crosshatch 3	
Diagonal 1	
Diagonal 2	
Diagonal 3	
Diagonal 4	

Name	Pattern
Diagonal 5	
Earth 1	
Earth 2	
Grass	
Gravel 1	
Gravel 2	
Gravel 3	
Gravel 4	
Horizontal 1	
Horizontal 2	
Horizontal 3	

Name	Pattern
Sand	
Wood 1	
Wood 2	
Wood 3	
Wood 4	
Wood 5	
Wood 6	
Wood 7	
Wood 8	

2.2.8 Model Patterns

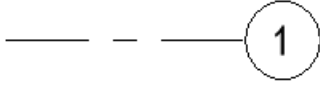
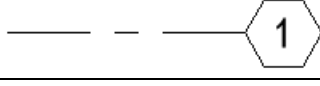

Table 2-8 : Model Patterns

Name	Pattern
Block 200x200	
Block 200x400	
Brick 75x225	
Brick 80x240	

Name	Pattern
Crosshatch h 150x150	
Crosshatch h 610x1220	
Crosshatch h 610x610	

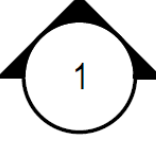
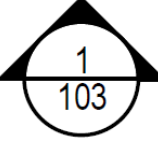
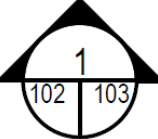

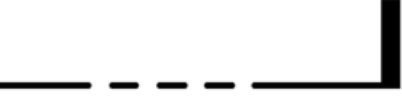
2.2.9 Grids and Levels

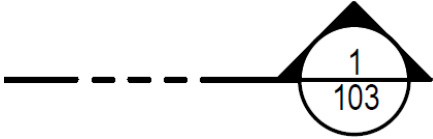

Table 2-9 : Grid and level types

Type Name	Description
Grid: Head - Bubble	
Grid Head - Hexagon	
Level: Head	

2.2.10 Section Callout




Table 2-10 : Section callout family types

Type Name	Section Head / Tail
Section Callout 0	
Section Callout 1	
Section Callout 2	
No Tail	
Section Tail	

Type Name	Section Head / Tail
Section Head (matching)	
Section Tail - Horizontal	

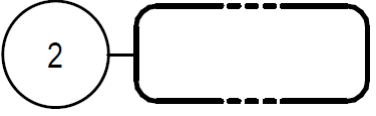

2.2.11 Elevation Callout

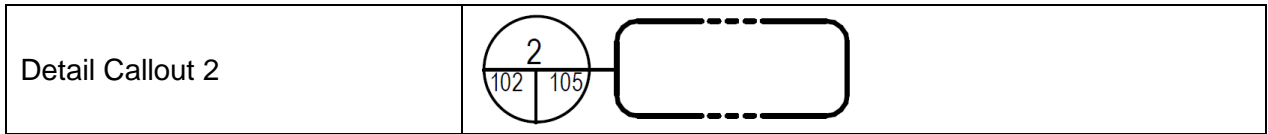
Table 2-11 : Elevation callout family types

Type Name	Elevation Head
Elevation Callout 0	
Elevation Callout 1	
Elevation Callout 2	

2.2.12 Detail Callout

Table 2-12 : Detail callout family types

Type Name	Elevation Head
Detail Callout 0	
Detail Callout 1	



2.3 Project Parameters

Table 2-13 : Custom project parameters

Project Parameter	Parameter Instance Category	Parameter Category
Date Approved	Sheet	Identity Data
Date Designed	Sheet	Identity Data
Date Drawn	Sheet	Identity Data
Date Reviewed	Sheet	Identity Data

2.4 Shared Parameters

The shared parameters file can be downloaded at [Shared_Parameters.txt](#)

2.5 Units

The units in the PSCP Revit template are configured for the metric system.

2.6 Project Browser

Views in the project browser have been grouped first by discipline, then by family and type, and finally sorted in ascending alphabetical order.

The discipline breaks down into 6 categories. The Architectural, Structural, Mechanical, Electrical and Plumbing categories are for design views that are placed on sheets. The Coordination category is for other views that support the project such as sketches, design changes or even temporary views. Coordination views are generally not placed on sheets.

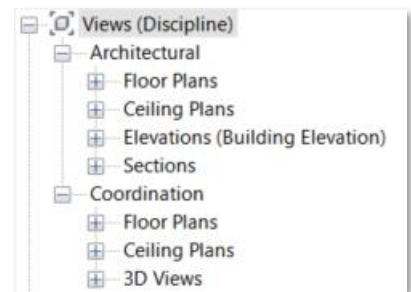


Figure 2-1 : Project browser

Sheets and schedules views are sorted in alphabetical order.

2.7 Using Views

Views enables the display and manipulation of the project. Views are to be customized as required based on the need of the project or design method.

As stated in the project browser section, the PSPC templates organize views by discipline and therefore must have the discipline set for each view. Views related to design should be placed under their respective design category (Architectural, Structural, Mechanical, Electrical, Plumbing). Each view used to support the design or constructions team such as a sketch or design change, should be placed under Coordination.

2.8 Starting View





The template is configured to use a starting view to reduce load time when opening large files. The sheet title 00-Starting View will display by default each time the Revit project is opened.

2.9 Object Styles

The Object Styles tool has been configured with line weights, line colors, line patterns and materials for categories and subcategories of model elements and annotations.

2.10 Phases – Graphics Overrides

Table 2-14 : graphics overrides for phases

Graphic Overrides	Description
New	
Existing	
Demolished	
Temporary	

3. PSPC Revit Library

The PSPC Revit Library is a RVT file as a library which contains a collection of system families, loadable families often used at PSPC that can be reused on projects.

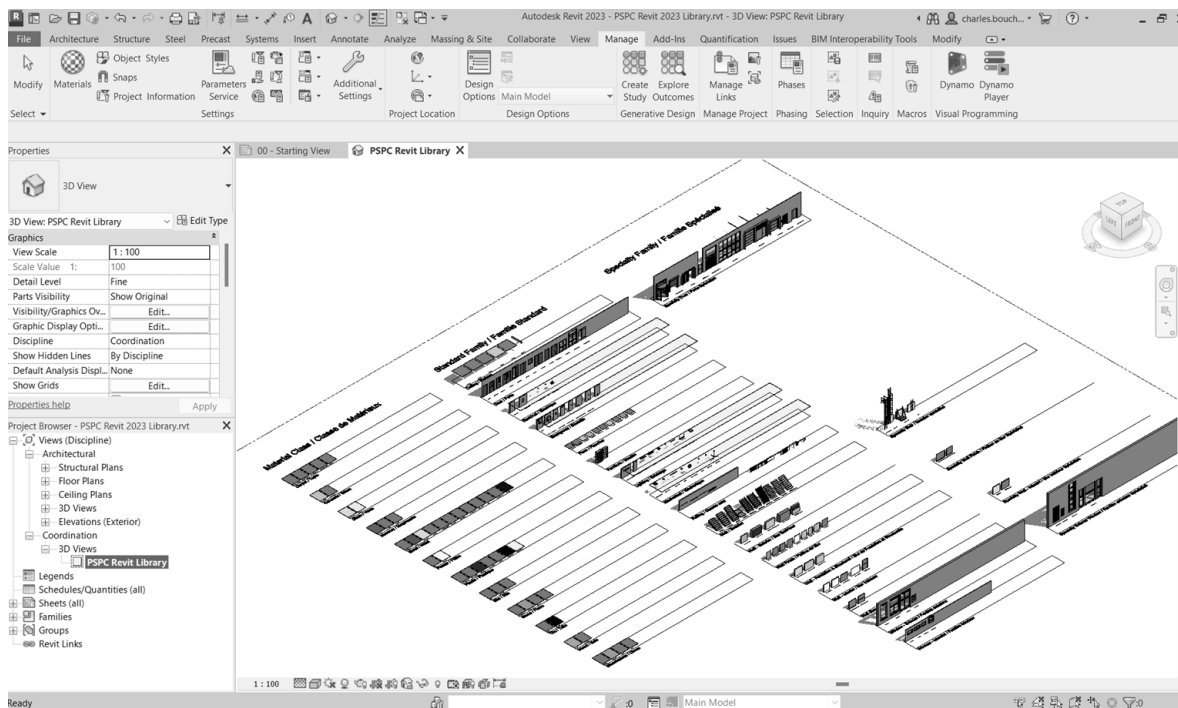
3.1 Download the PSPC Revit Library

Open this link to download and save the RVT file a familiar location.

- [PSPC Revit Library 2023.rvt](#)

3.2 Library overview

Figure 3-1 : 3D View of the PSPC Revit Library



3.2.1 Import system families

System families represents wall, roof, floor, stairs, ramps, railings, etc. and can be imported using the following methods:

- Copy and paste system families from one file to another.
- Transfer system families from one file to another using Transfer Project Standards.

For more information and a video demonstration, refer to the [Autodesk Revit 2023 Online Help](#).

3.2.2 Import loadable families

Loadable families represent building components (windows, doors, casework, fixtures, furniture, planting), system components (boiler, water heaters, air handlers, plumbing fixtures) and some annotations elements (symbols and title blocks).

Loadable families can be imported using the following methods:

- Copy and paste loadable families from one file to another.
- Save and load families from one file to another.

For more information, refer to the [Autodesk Revit 2023 Online Help – Load and Save Families](#).

3.2.3 PSPC Title blocks

The PSPC Title blocks are found under the Project Browser > Sheets and can be imported by using the following methods:

- Copy and paste the title block family from one file to another on a blank sheet.
- Save and load the title block family from one file to another.

For more information, refer to the [Autodesk Revit 2023 Online Help – Load and Save Families](#).


4. Revit DWG Export procedure


The Revit DWG Export procedure leverages the DWG Export command and a pre-configured DWG Export Setup.

4.1 Important usage information

- This procedure does not provide or warranties a full compliance with the PSPC National CADD Standard.
- After the completion of this procedure, the exported drawings must be reviewed for compliance with the PSPC National CADD Standard and modified as needed.
- Knowledge and familiarity of the PSPC National CADD Standard is essential prior to working on a Revit project.
- Families and family types used in the project must be compatible with PSPC National CADD Standard. Take advantage the of the pre-configured Revit content found in the PSPC Revit Template and Library (i.e.: Title blocks, annotations, configurations, etc.).
- All crop regions must be sized to fit inside the title block.
- Linked or imported content within a Revit project must be compliant with the PSPC National CADD Standard.

4.2 DWG Export procedure

1. Download the PSPC Revit Template. See section *2.1 Download the PSPC Revit Template* for instructions.
2. Open the Revit project file with the sheets to be exported.
3. If the Revit project file is based on the PSPC Revit Template please skip to step 8.
4. Open the PSPC Revit Template file.
5. While keeping the PSPC Revit Template opened, switch to the Revit project tab.
6. Go to Manage tab > Settings panel >  (Transfer Project Standards).
7. In the Select Items to Copy dialog, do the following:
 - a. for Copy from select the PSPC Revit Template
 - b. Click Check None to deselect all items.

-
- c. Only select the DWG/DXF Export Setup Settings.
 - d. Click OK.
 8. Click File tab > Export > CAD Format  (DWG).
 9. In the DWG Export dialog, for Select Export Setup, select the PSPC Revit CADD Export.
 10. For Export, select <In session view/sheet set>, and then select the sheets to export.
 11. Click Next.
 12. In the Export CAD formats dialog, do the following:
 - a. Navigate to the target folder for the exported files.
 - b. For Files of type, select an AutoCAD version for the exported DWG file(s).
 - c. For Naming, select Automatic – Short.
 - d. Clear the checkbox for Export views on sheets and links as external references.

Revit exports the selected sheets and places the files in the target folder.