

new products bulletin

This monthly bulletin is published to inform Canadian industry of licensing and joint venture opportunities that may be investigated for the purpose of forming manufacturing affiliations. The Department cannot assume any responsibility for claims made or for transactions which ensue from the publication of any items in this bulletin. If you are interested in any of the proposals you should contact the correspondent identified with the item and send a copy of your initial correspondence to the Canadian Government Trade Commissioner responsible for the area at the address indicated, in order that he can provide appropriate assistance or commercial information.

The Licensing Opportunities Section (34/3) of the BUSINESS CENTRE of the Department of Industry, Trade and Commerce, Ottawa, Ontario K1A 0H5 (Telephone: (613) 995-5771) should be advised of any agreements concluded as a result of this publicity.

bulletin de produits nouveaux

Le présent bulletin, publié tous les mois, a pour objet d'informer l'industrie canadienne d'occasions de fabrication sous licence et d'entreprise en participation qu'il est possible d'étudier aux fins de constituer des affiliations manufacturières. Le Ministère ne peut assumer aucune responsabilité à l'égard des réclamations ou transactions découlant de la publication d'articles dans le présent bulletin. Si l'une ou l'autre des propositions vous intéresse, auriez-vous l'obligance de communiquer avec le correspondant et transmettre copie de votre premier échange de correspondance au délégué commercial du Gouvernement du Canada qui s'occupe de la région en cause, à l'adresse indiquée, afin qu'il puisse vous fournir l'aide ou les renseignements commerciaux pertinents.

Prière d'informer la Section des possibilités de licences (34/3), du CENTRE DES ENTREPRISES, ministère de l'Industrie et du Commerce, Ottawa (Ontario) K1A 0H5 (Téléphone: (613) 995-5771), de toute entente intervenue à la suite de la présente publicité.

AUGUST 1979

BULLETIN 283

AOÛT 1979

Electric Auto Bumper Jack

American development corporation offers the worldwide manufacturing and marketing rights to a Canadian company for its U.S. patented portable push-button electric auto jack that plugs into a car's cigarette lighter and raises any car without physical exertion. The jack has a normally upright threaded spindle journaled in a base and rotated by a reversible electric motor releasably mounted in the base. An internally threaded sleeve on the spindle carries a bumper-engaging bracket. The motor is connected to the spindle by a coupling having a polygonal input member and a mating socket member on the motor dimensioned for turning the polygonal head screws which fasten the wheels of a motor car to the axle. The jack is claimed to use no more power than an electric window. Address enquiries to: Mr. J.W. Leonard, Products International, G.P.O. Box 350, New York, N.Y. 10001. Please send a copy of your initial correspondence to: Canadian Consulate General, 1251 Avenue of the Americas, New York City, N.Y. 10020.

Orthopaedic Instrument

Israeli manufacturer offers the Canadian manufacturing and marketing rights to its "Footprint" instrument designed to measure the distribution of the force between the foot and the ground. Other marketing rights excluding the U.S. are negotiable. The instrument is useful in diagnosing various orthopaedic conditions, guiding and following up lower limb surgery, prosthesis, alignment, design and prescription of corrective inserts and rehabilitation. The test subject stands on a special sole which determines the points at which the local force is measured optically (or the sole is replaced by a

Cric électrique pour automobiles

Une société américaine d'exploitation offre à une société canadienne les droits mondiaux de fabrication et de commercialisation de son cric électrique portatif pour automobiles, breveté aux E.-U., qui se branche dans l'allume-cigares et soulève toute automobile sans effort physique. Le cric a un axe vertical fileté, fixé dans une base, qui tourne grâce à un moteur électrique amovible à mouvement réversible, actionné par poussoir et également monté dans la base. L'axe est recouvert d'un manchon à filetage interne au bout duquel est fixé le support du parechocs. Le moteur est branché à l'axe vertical au moyen d'un mécanisme de couplage permettant d'adapter la douille polygonale de l'axe du moteur, douille qui permet également de dévisser les boulons des roues avec le moteur. Le cric est réputé ne pas consommer plus de courant qu'une fenêtre électrique. Faites parvenir vos demandes de renseignements à: M. J.W. Leonard, Products International, G.P.O. Box 350, New York, N.Y. 10001. Veuillez transmettre une copie de votre correspondance initiale au: Consulat général du Canada, 1251 Avenue of the Americas, New York City, N.Y. 10020.

Appareil orthopédique

Un fabricant israélien offre les droits de fabrication et de commercialisation de son appareil "Footprint", qui permet de mesurer la distribution de la force exercée entre le pied et le sol. D'autres droits de commercialisation, sauf pour les E.-U., sont négociables. L'appareil sert à diagnostiquer diverses conditions orthopédiques, à orienter et contrôler la chirurgie des membres inférieurs, les prothèses, le redressage, la conception et la prescription de pièces correctives ainsi que la réhabilitation. La personne qui subit le test se tient debout sur une semelle spéciale qui détermine les points où la force locale se mesure par un procédé visuel. On peut remplacer



Government
of Canada

Gouvernement
du Canada

Industry, Trade
and Commerce

Industrie
et Commerce



Gouvernement
du Canada

Government
of Canada

Industrie
et Commerce

Industry, Trade
and Commerce

mat). Forces are measured by optical interference and the size of the outer circular pattern around each point determines the magnitude of the local force at that point. Operating the instrument requires no special training. It works on a simple optical principle, has no electronic or moving parts and is essentially maintenance free. See illustration. Address enquiries to: Ramot, 6 Levitan Street, Ramat Aviv, Tel Aviv, Israel. Please send a copy of your initial correspondence to: Commercial Division, Canadian Embassy, 220 Hayarkon Street, Tel Aviv, Israel.

Chaplets

West German company seeks a joint venture partner in Canada to manufacture and market in North America chaplets to be used with thin walled castings. The firm has been manufacturing foundry equipment for over one hundred years. Its newly developed tablets have proven a means of completely eliminating 1) the lack of tightness of castings, i.e., castings showing formation of buddles at the riveting joints caused by badly-welded chaplets; 2) the development of rust on stems or iron sheets of the chaplets; 3) the formation of vapour on the damp moulds; and 4) pollution of all kinds. By placing chaplets on a flat tub-shaped tray (tablet) before casting, the tablet and the chaplet are placed into the mould. The tablet has perforations or indents on its edges so that it can be easily moulded with the castings to ensure safe welding of the chaplet. Chaplets of all known systems can be placed on tablets and cast as before. One or two stem chaplets with one or two tablets have been developed as sheet metal trays for chaplets and have proven very successful. They combine the advantages of the tablet in a chaplet and, above all, allow for the best possible welding of the surfaces of the mould and chaplet. The firm also produces foundry cooling apparatus of all kinds and sizes and without pointed tips for fixing as well as apparatus from killed siliconized steels, alloyed steels, aluminum, copper and brass. See illustration. Address enquiries to: Ludwig Foebus KG, Ringofenstr. 13, D-4600 Dortmund 41, Germany. Please send a copy of your initial correspondence to: Canadian Consulate General, Immermannstrasse 3, 4 Duesseldorf, West Germany.

Centrifugal Casting Process for Large Pipes

German company offers an exclusive license to manufacture large diameter pipes of polyamide by a process which utilizes centrifugal casting in situ anionic polymerization of Caprolactam. Pipes of up to 6 metres in length and from 150 to 800mm diameter can be fabricated by this technique. The

la semelle par un tapis. Les forces sont mesurées par interférence optique et la taille du modèle circulaire externe autour de chaque point détermine l'ampleur de la force locale à ce point. Aucune formation spéciale n'est requise pour actionner cet appareil. Il fonctionne d'après un simple principe visuel, ne possède aucune pièce électronique ou mobile et ne nécessite pratiquement pas d'entretien. Voir l'illustration. Pour plus de renseignements, veuillez communiquer avec: Ramot, 6 Levitan Street, Ramat Aviv, Tel Aviv, Israel et adresser une copie de votre correspondance initiale à la: Division commerciale, Ambassade du Canada, 220 Hayarkon Street, Tel Aviv, Israel.

Supports de noyau

Une société de la République fédérale d'Allemagne est à la recherche d'un partenaire canadien en vue d'une entreprise en participation pour la fabrication au Canada et la commercialisation, en Amérique du Nord, de supports de noyau de pièces de fonte à parois minces. Cette entreprise fabrique du matériel de fonderie depuis plus de cent ans. Ses entablements, récemment mis au point, se sont avérés un moyen d'éliminer complètement 1) le manque d'étanchéité des pièces coulées, c'est-à-dire, des pièces permettant la formation de bulles de gaz aux joints de rivetage, vu le mauvais soudage des supports, 2) la formation de rouille sur les tiges ou feuilles métalliques des supports, 3) la vapeur sur les parois des moules humides, et 4) la pollution provenant de toute source. L'entablement et le support sont installés dans le moule, antérieurement à la coulée, en montant les supports sur un plateau (entablement) en forme de baquet. Les arêtes de l'entablement sont perforées ou adentées afin qu'il soit facilement moulé avec les pièces coulées pour en assurer une soudure sûre au support. Les supports de noyau de tous les systèmes connus peuvent être placés sur des entablements et coulés selon la méthode utilisée auparavant. Des supports de une ou deux tiges comportant un ou deux entablements ont été mis au point; il s'agit de baquets de métal en feuilles pour les supports et ils se sont avérés très réussis. Ils combinent les avantages de l'entablement incorporé au support et, par-dessus tout, ils permettent la meilleure soudure possible des surfaces du moule et du support. L'entreprise fabrique aussi de l'appareillage de refroidissement de fonderie de tous genres et de toutes tailles sans extrémités pointues, pour les aciers silicieux, les aciers spéciaux, l'aluminium, le cuivre et le laiton calmés. Voir l'illustration. Faire parvenir les demandes à M. Ludwig Foebus KG, Ringofenstr. 13, D-4600 Dortmund 41, (République fédérale d'Allemagne). Transmettre une copie de votre correspondance initiale au Consulat général du Canada, Immermannstrasse 3, 4 Düsseldorf (République fédérale d'Allemagne).

Procédé de moulage centrifuge pour gros tuyaux

Une société allemande offre la licence exclusive de fabrication pour des tuyaux de polyamide à diamètre élevé par un procédé de moulage centrifuge avec la polymérisation anionique sur place de caprolactame. Cette technique permet de fabriquer des tuyaux pouvant mesurer jusqu'à 6 mètres, avec un diamètre de 150 à 800 mm. Le tuyau est réputé

pipe is claimed to have superior abrasion resistance and is only one quarter the weight of equivalent steel pipe used for many low pressure applications. The pipe has been marketed to a limited extent since 1977 and is considered ideally suited for dredging, mining and industrial applications involving the hydraulic conveyance of solids. See illustration. Address enquiries to: Jung-Werke GmbH, Postfach 17, 5241 Wehbach/Sieg, West Germany. Please send a copy of your initial correspondence to: Canadian Consulate General, Immermannstrasse 3, 4 Duesseldorf, West Germany.

Automatic Sampler

French National agency for research development offers exclusive or non-exclusive licensing rights to a Canadian company to manufacture its patented and commercially proven automatic sampler for dry products. Export rights will be considered. Patented in 12 countries, the device consists of a pneumatic jack that operates a volumetric sampler to which different movements can be imparted for the removal of 100cm³ of granular or powdery products in less than one second. Various devices and improvements make it possible to ensure non-deterioration of the particles removed and impervious to inside and outside dust; to prevent particles from forming a blockage or bouncing when the flow is heavy; the sampler can be adapted to different spots in a production line; and permit programmable quality controls in the chemical, pharmaceutical, agricultural, food and other industries. In view of the manifold uses, it is desirable for the licensee to have contacts in a broad range of industries and national or international marketing facilities. Address enquiries to: ANVAR - Agence nationale de valorisation de la recherche, 13, rue Madeleine Michelis, 92522 Neuilly-sur-Seine, France. Please send a copy of your initial correspondence to: Commercial Division, Canadian Embassy, 35 Avenue Montaigne, 75008 Paris, France.

Knock-Down Furniture System

West German manufacturer of a specialized system of knock-down wall furniture is interested in locating a qualified licensee in Canada. Composed of a number of component parts that can be arranged into an almost limitless range of units, one of the systems is finished in a white/grey plastic which is easy to clean and hygienic. Styling is appealing and functional with market potential through "do-it-yourself" outlets. Licensing arrangements are also available for a wood K/D chair, table and day bed system. Canadian patents have been issued on the arm chair and "Farmer" knock-down furniture system. Address enquiries to: Mr. Rudolf Baresel-Bofinger, Gutenbergstrasse 39, D 7100 Heilbronn, West Germany. Please send a copy of your initial correspondence to: Canadian Consulate General, Immermannstrasse 3, 4 Duesseldorf, West Germany.

avoir une résistance supérieure à l'abrasion et ne pèse que le quart du poids des tuyaux d'acier équivalents souvent utilisés à basse pression. Depuis 1977, le tuyau a connu une commercialisation limitée et on le considère idéal pour les activités industrielles, minières et de dragage où il faut transporter des solides dans l'eau. Voir l'illustration. Faites parvenir vos demandes de renseignements à: Jung-Werke GmbH, Postfach 17, 5241 Wehbach/Sieg, Allemagne de l'Ouest. Veuillez transmettre une copie de votre correspondance initiale au Consulat général du Canada, Immermannstrasse 3, 4 Duesseldorf, Allemagne de l'Ouest.

Échantillonneuse automatique

Une agence nationale française de recherche et de développement offre les droits exclusifs ou non exclusifs de licence à une société canadienne pour la fabrication de son échantillonneuse automatique de produits secs brevetée qui a fait ses preuves sur le marché. Les droits d'exportation sont considérés. Breveté dans 12 pays, cet appareil est constitué d'un vérin pneumatique qui actionne une sonde volumétrique à laquelle on peut imprimer divers mouvements pour le prélèvement de 100 cm³ de produits granuleux ou en poudre en moins d'une seconde. Divers accessoires et perfectionnements permettent d'assurer que les particules prélevées ne se dégraderont pas et de rendre l'appareil étanche à la poussière intérieure et extérieure; d'empêcher les engorgements et les refoulements en période de fort débit; l'échantillonneuse peut s'adapter à divers endroits dans une chaîne de production et se prête à des contrôles de qualité programmables dans les industries chimique, pharmaceutique, agricole, alimentaire et autres. Étant donné la polyvalence de l'échantillonneuse, il serait bon que le détenteur de licence ait des contacts dans une gamme étendue d'industries et dispose d'un réseau de commercialisation national ou international. Prière d'adresser les demandes de renseignements à: ANVAR - Agence nationale de valorisation de la recherche, 13, rue Madeleine-Michelis, 92522 Neuilly-sur-Seine (France). Veuillez faire parvenir copie de votre correspondance initiale à la Division commerciale, Ambassade du Canada, 35 avenue Montaigne, 75008, Paris (France).

Système d'ameublement démontable

Le fabricant ouest-allemand d'un système spécialisé d'ameublement mural démontable cherche un fabricant canadien compétent désirant obtenir une licence. Composé de plusieurs éléments pouvant être combinés presque à l'infini, l'un des systèmes est recouvert de plastique gris/blanc hygiénique facile à nettoyer. Le style est fonctionnel et attrayant et se prêterait à la commercialisation dans les magasins pour bricoleurs. On offre également une licence pour un ensemble démontable en bois comprenant la chaise, la table et le lit de repos. Il existe des brevets canadiens pour le fauteuil et le système d'ameublement démontable "Farmer". Veuillez faire parvenir vos demandes de renseignements à M. Rudolf Baresel-Bofinger, Gutenbergstrasse 39, D 7100 Heilbronn, Allemagne de l'Ouest. Transmettre une copie de votre correspondance initiale au Consulat général du Canada, Immermannstrasse 3, 4 Duesseldorf, Allemagne de l'Ouest.

Boilers

Dutch company offers the manufacturing and marketing rights, outside the European Continent, to a Canadian manufacturer for its new generation gas and oil fired boilers (developed to the prototype tested stage) which transfer more heat to central water heating systems than conventional boilers and reduce to a bare minimum, heat losses into the environment. Fired in an entirely insulated system, hot combustion gases are circulated through the boiler by a ventilator (controlled by a circuit which also electrically ignites the burner and secures the flame by an ionization device) whereby part of their heat is transferred to the cooled firing chamber and to the heat exchanger right above it. The gas flow is subsequently reversed and led through a second heat exchanger installed where the combustion air flows, thus preheating it and cooling down the combustion gases to an extent that water vapour condenses and is discharged via a drain, i.e., the heat released in the condensation process is additionally recovered. When leaving the boiler, the combustion gases, saturated with the remainder of the water are mixed with air to such an extent that further condensation in the flue gas stack is suppressed or avoided. The ventilator draws combustion gases from the boiler, causing a draught which draws in combustion air. Since the boiler is entirely insulated, noise is kept to a minimum. The boiler can be constructed as chimney or balanced gas flue types. Depending on the temperature of the boiler water the maximum waterside efficiency is 86 to 96% on gross calorific value basis (= 94 to 106% on net calorific value). At an average water temperature of 45°C the overall efficiency has been determined by the so-called part load method (93% on gross calorific value = 102% on net calorific value). The anticipated power consumption is 6 watts based on 6 cycles per hour. Address enquiries to: N.V. Nederlandse Gasunie, P.O. Box 19, 9700 MA Groningen, Netherlands. Please send a copy of your initial correspondence to: Commercial Division, Canadian Embassy, Sophialaan 7, The Hague, Netherlands.

Three-Jaw Vise

American inventor offers the exclusive manufacturing and marketing rights to a Canadian company capable of mass production and distribution, for his U.S. patented three-jaw machinists and craftworkers vice. This product was designed for gripping odd shaped articles such as spheres, wedges, rocks, wood carvings, cylinders, etc. Geometrically, it consists of one fixed jaw and two moving jaws so coordinated in motion that the three jaws are always an equal distance from one another. Jaws are floating and have different faces for gripping various objects. The vise may be clamped to a bench in two different ways or the clamps may be removed for use on a drill press, mill or grinder. Engineering drawings of a 2" capacity cast iron model and an

Chaudières

Une société néerlandaise offre à un fabricant canadien les droits de fabrication et de commercialisation à l'extérieur du continent européen de ses chaudières au gaz et au mazout ultramodernes (ayant atteint le stade de prototype mis à l'essai) qui transfèrent plus de chaleur aux systèmes de chauffage centraux que les chaudières conventionnelles et qui réduisent au minimum les pertes de chaleur dans l'environnement. Des gaz de combustion chauds produits dans un système entièrement isolé circulent dans la chaudière à l'aide d'un ventilateur (commandé par un circuit qui, selon un procédé électrique, allume le brûleur et produit une flamme à l'aide d'un appareil ionisant) et une partie de la chaleur est transférée à la chambre de combustion refroidie et à l'échangeur de chaleur qui se trouve juste au-dessus. Le flux de gaz est renversé par la suite et acheminé par l'entremise d'un deuxième échangeur de chaleur installé là où circule l'air de combustion. L'échangeur se trouve ainsi à préchauffer et à refroidir les gaz de combustion et la vapeur d'eau se condense, puis s'écoule par un drain. La chaleur émise dans le procédé de condensation est aussi récupérée. Lorsqu'ils quittent la chaudière, les gaz de combustion saturés avec le reste de l'eau se mêlent à l'air, ce qui fait que toute condensation ultérieure dans le tube de fumée est supprimée ou évitée. Le ventilateur aspire les gaz de combustion provenant de la chaudière, ce qui produit un tirage qui aspire l'air de combustion. Comme la chaudière est entièrement isolée, il n'y a presque pas de bruit. On peut donner à la chaudière la forme d'une cheminée ou d'un appareil à tirage équilibré. Les variations de température de l'eau de la chaudière, donnent un rendement maximal côté eau de 86 % à 96 % si l'on se base sur la valeur calorifique brute (=94 tot. 106 % sur la valeur calorifique nette). A une température d'eau moyenne de 45°C, la soi-disant méthode de charge partielle détermine le rendement global (93 % sur la valeur calorifique brute = 102 % sur la valeur calorifique nette). La consommation d'énergie prévue: 6 watts à 6 cycles par heure. Veuillez adresser vos demandes de renseignements à: N.V. Nederlandse Gasunie, C.P. 19, 9700 MA Groningen, Pays-Bas, et faire parvenir une copie de votre correspondance initiale à la Division commerciale, Ambassade du Canada, Sophialaan, La Haye, Pays-Bas.

Étau à triple mâchoire

Un inventeur américain offre des droits exclusifs de fabrication et de commercialisation à une compagnie canadienne, capable de produire en série et de distribuer son étau à trois mâchoires pour machinistes et artisans, breveté aux États-Unis. Le produit en question a été conçu pour prendre des articles de forme capricieuse tels que sphères, chevilles, roches, sculptures sur bois, cylindres, etc. Du point de vue géométrique, l'étau consiste en une mâchoire fixe et deux mâchoires mobiles coordonnées de telle sorte que, lorsqu'elles sont en mouvement, les mâchoires sont toujours à égale distance l'une de l'autre. Les mâchoires sont mobiles et comportent diverses surfaces permettant la prise d'objets divers. L'étau peut être fixé à un établi de deux manières différentes, et les mordaches peuvent être enlevées et utilisées

aluminum prototype are available from the inventor. Address enquiries to: Mr. Grey M. Gurley, NATO, P.O. Box 1418, Sarasota, Florida 33578. Please send a copy of your initial correspondence to: Canadian Consulate General, 900 Coastal States Building, 260 Peachtree Street, Atlanta, Georgia 30303.

Reversing Valves

American inventor seeks a Canadian company having national or international marketing facilities to manufacture and market his reversing valves for heat pumps under an exclusive licensing arrangement in Canada. In this system, the internally piloted working fluid shifts the stem inside the hermetically sealed housing by energizing the solenoid operators through momentary contact, whereas other heat pump valves use energy for at least 50% of their service life. Claimed to be an efficient, simple and cost competitive switching reversing valve, it can be used as a diverter, can double as a mixer valve when 3-ported or, when 5-ported, serve not only heat pumps in air conditioning and refrigeration systems but also solar and/or cooling tower systems requiring flow reversal. It will also serve in processes requiring control of supply and for mixing two different fluids in a single receiver, plus other chemical, process, energy and automation applications. Made in an uncomplicated manner from conventional equipment, the valves can meet customer specifications from sizes #10-32 to 2NPT with more than ample flow coefficient, for pressures up to 500 psig from any material that is compatible with the fluids to be valved. Interested Canadian manufacturers will be required to sign a confidential disclosure agreement prior to receiving production drawings, prototypes, know-how, technical assistance, and names of other licensees. Address enquiries to: Mr. R.S. Pauliukonis, President, Patentrol Corporation, 6660 Greenbriar Drive, Cleveland, Ohio 44130, U.S.A. Please send a copy of your initial correspondence to: Canadian Consulate, Illuminating Building, 55 Public Square, Cleveland, Ohio 44113.

Baffle for Gas Heater Vents

Canadian inventor offers an exclusive license to a Canadian company to manufacture and market a baffle for a gas heater vent which protrudes on the outside wall of a small home in which a gas heater is installed. It consists of a sheet metal rectangular baffle which encloses the front, sides and part of the top of the vent part, and is attached to the wall

sur une perceuse d'établi, une fraise ou une meule affûteuse. On peut se procurer auprès de l'inventeur les dessins d'ingénierie d'un modèle en fonte d'une capacité de 2" ainsi qu'un prototype en aluminium. Veuillez adresser vos demandes de renseignements à: M. Grey M. Gurley, OTAN, C.P. 1418, Sarasota, Floride 33578. Prière de faire parvenir votre correspondance initiale au: Consulat général canadien, 900, Coastal States Building, 260, Peachtree Street, Atlanta, Georgie 30303.

Robinet inverseurs

Un inventeur américain recherche une société canadienne possédant un réseau de commercialisation national ou international pour fabriquer et commercialiser ses robinets inverseurs pour pompes à chaleur en vertu d'un accord de licence exclusif au Canada. Il s'agit d'un système selon lequel un fluide à circulation interne pousse la tige à l'intérieur du corps de l'appareil scellé hermétiquement en actionnant des solénoïdes par contact momentané. Habituellement, les robinets de pompes à chaleur utilisant l'énergie pendant au moins 50 % de leur durée. Ces robinets inverseurs qui, selon l'inventeur, sont efficaces, simples et offerts à des prix concurrentiels peuvent servir d'appareil à faire dévier le flux et aussi de robinet mélangeur lorsqu'un système comporte 3 orifices. Lorsque le système comporte 5 orifices, ils s'appliquent non seulement aux pompes à chaleur des systèmes de climatisation et de réfrigération, mais aussi aux systèmes solaires et aux tours de refroidissement qui nécessitent un renversement du flux. Elles peuvent servir aussi aux procédés nécessitant un contrôle de l'alimentation, au mélange de deux différents fluides dans un seul réservoir et à d'autres procédés chimiques, d'énergie et d'automatisation. Le système est simple par rapport aux équipements conventionnels. Les soupapes peuvent être fabriquées selon les spécifications propres de chaque client. Les formats offerts sont de 10-32 à 2NPT avec coefficient permettant un flux plus que considérable pour des pressions manométriques allant jusqu'à 500lb/po.ca. de tout matériel compatible avec les fluides dont il faut contrôler le courant. Les fabricants canadiens intéressés devront signer un accord de divulgation avant de recevoir les plans de production, les prototypes, une aide technique et avant qu'on leur communique le savoir-faire et les noms des autres détenteurs de licences. Faire parvenir toute demande de renseignements à M. R.S. Pauliukonis, président, Patentrol Corporation, 6660 Greenbriar Drive, Cleveland (Ohio) 44130, E.-U. Veuillez adresser une copie de votre correspondance initiale au: Consulat du Canada, Illuminating Building, 55 Public Square, Cleveland (Ohio) 44113.

Écran protecteur pour événements d'appareils de chauffage au gaz

Un inventeur canadien offre la licence exclusive à une compagnie canadienne pour la fabrication et la commercialisation d'un écran protecteur pour événements d'appareils de chauffage au gaz, l'écran en question faisant saillie sur le mur extérieur d'une petite maison dans laquelle un appareil de chauffage au gaz est installé. Il s'agit d'un écran rectangulaire en tôle recouvrant le devant, les côtés et une partie du haut de l'évent; l'écran est rattaché au mur de la bâtisse. Une autre

of the building. A variation of the invention provides for the easy removal and reattachment of the baffle. Another variation fully encloses the top and bottom of the baffle, provides a chimney for the discharge of gases at the top of the baffle, and a rain and snow shield for the top of the chimney. Canadian and U.S. patents are pending. The invention is not suitable for large furnaces. Address enquiries to: Mr. Lawrence J. Pieschke, P.O. Box 171, South Woodslee, Ontario NOR 1V0. Please send a copy of your initial correspondence to: The Licensing Opportunities Section (34/3), Business Centre, Department of Industry, Trade and Commerce, Ottawa, Ontario K1A 0H5.

Equipment for Digital Load Evaluation

Czechoslovak Foreign Trade Agency offers the manufacturing and marketing rights to a Canadian company for its method of digital load evaluation of machinery based on measurement of the main functional part of the equipment whereby it is possible to preselect the whole range of loading with the material to be processed. The logic output circuits help to control dosing of the material so that loading with the material is kept within two chosen limits. The equipment has a wide variety of uses, for instance, for controlling the filling of crushers where the variety of geometrical dimensions and physical properties of the processed material do not allow the use of analogue control. The instrumental part of the equipment can be easily built with the use of currently available digital equipment. Plants equipped with computers can use the method within their computer program, thus eliminating the construction of special equipment for this purpose. Compared with known and currently used methods of controlling the filling operation, the new method is notable for outstanding discerning capacity and maximum objectivity in evaluation — relatively error free due to analogue measurement and processing of the information data. Filling control of the production equipment makes it possible to increase outputs and reduce the consumption of electric energy; the human factor can be entirely eliminated in machines where filling is manually controlled. Address enquiries to: Mr. Jan Volny, Polytechna, P.O. Box 834, Pranska 9, 11245 Praha 1, Czechoslovakia. Please send a copy of your initial correspondence to: Commercial Division, Canadian Embassy, Mickiewiczova 6, 125 33 Prague 6, Czechoslovakia.

Treatment of Waste Waters from Chemical Preparation of Uranium Ore and Recovery of Utilisable Substances

Czechoslovakian Foreign Trade Corporation offers a Canadian company the North American rights to its patented method for treating waste waters from chemical preparations of uranium ore and recovery of utilisable substances. The waste waters are thickened by evaporation to a state of almost

version de l'invention permet d'enlever l'écran et de la remettre en place facilement. Il en existe une autre variation: cette dernière recouvre complètement le haut et le bas de l'écran, fait fonction de cheminée pour la libération des gaz par le haut de l'écran protecteur et de protection contre l'entrée de la pluie et de la neige par le haut de la cheminée. Les brevets canadien et américain sont en instance. L'invention ne convient pas aux grandes chaudières. Veuillez adresser vos demandes de renseignements à: M. Lawrence J. Pieschke, C.P. 171, South Woodslee (Ontario) NOR 1V0. Veuillez envoyer copie de votre correspondance initiale à: Section des possibilités de licences (34/3) du Centre des entreprises, ministère de l'Industrie et du Commerce, Ottawa (Ontario) K1A 0H5.

Matériel pour l'évaluation numérique des charges

Un organisme tchèque de commerce extérieur offre à une entreprise canadienne les droits de fabrication et de commercialisation de sa méthode d'évaluation numérique des charges imposées aux machines fondée sur la mesure de la principale pièce fonctionnelle du matériel permettant de présélectionner toute la gamme des charges avec la matière à traiter. Les circuits de sortie logique aident à contrôler le dosage de matière de façon à le maintenir entre deux limites choisies. Le matériel se prête à une grande variété d'utilisations. Par exemple, il peut contrôler le remplissage des broyeurs dans les cas où la variété des dimensions géométriques et les propriétés physiques de la matière traitée ne permettent pas de recourir au contrôle analogique. La partie instrumentale du matériel est facile à construire avec les équipements numériques actuellement disponibles. Les usines munies d'ordinateurs peuvent employer cette méthode dans le cadre de leur programme d'informatique, ce qui supprime le besoin de construire des équipements spéciaux à cette fin. Comparativement aux méthodes connues et d'usage courant pour le contrôle des opérations de remplissage, la nouvelle méthode se fait remarquer par son exceptionnelles capacité de discernement et son objectivité maximale en évaluation — relativement exempte d'erreurs grâce à la mesure et au traitement analogiques des données. Le contrôle de remplissage appliqué aux équipements de production permet d'accroître les débits et de réduire la consommation d'énergie électrique. On peut tout à fait supprimer le facteur humain dans les machines où le remplissage est contrôlé à la main. Prière d'adresser les demandes de renseignements à M. Jan Volny, Polytechna, B.P. 834, Pranska 9, 11245 Prague 1, Tchécoslovaquie. Veuillez envoyer copie de votre correspondance initiale à la Division commerciale, Ambassade du Canada, Mickiewiczova 6, 125 33 Prague 6, Tchécoslovaquie.

Traitement des eaux usées provenant de la préparation chimique du minerai d'uranium et récupération des substances utilisables

Une société tchèque de commerce extérieur offre à une société canadienne les droits nord-américains pour son procédé breveté de traitement des eaux usées provenant de la préparation chimique du minerai d'uranium et de récupération des substances utilisables. Les eaux usées sont épaissies

full saturation with salt. By further evaporation or cooling, the least soluble non-radioactive salt components crystallize from the solution. The crystalline suspension produced separates into crystalline salt and the parent solution of residual salts, including uranium and the remaining radioactive components. The parent solution is recycled into the main manufacturing process where uranium gets precipitated while the salts remaining in the solution are used in the preparation of the agent for the elution of ion exchangers. In this way savings in the present acid consumption can be achieved. The distillation product of the process of thickening waste waters is conveyed to points of water consumption in the plant and is used instead of the water supplied from out-of-plant sources. After final cleaning by repeated crystallization, refining and quality testing, the separated crystalline salt can be passed from the uranium plant for use in such as the cellulose, dye and paint, glass, and detergent industries. Address enquiries to: Mr. Jan Volny, Section 26, Polytechna, Foreign Trade Corporation, Technical Cooperation Agency, Pranska 6, P.O. Box 834, 112 45 Praha 1, Czechoslovakia. Please send a copy of your initial correspondence to: Commercial Division, Canadian Embassy, Mickiewiczova 6, 125 33 Prague 6, Czechoslovakia.

EZT-2 Working Face Signalling and Protecting System – LF 00054

Czechoslovakian licensing agency offers the manufacturing and marketing rights in Canada for a system that provide increased safety in working faces of coal mines against the danger of gas outbursts and cave-ins. This radio signalling system permits any member of the crew to stop the face conveyer and, if needed, block its action. Transmitter connections make it possible to inform the crew of any dangerous situation and can be used in recovery operations. This system has the following functions: 1) transmitter connections with all workers at the working face and haulage roadway to a distance of up to 1 km; 2) immediate stoppage of the face conveyer or other mining machines through transmission of a block signal and blocking of the equipment; 3) deblocking of the equipment can be carried out only by the person who caused the blocking by transmission of the block signal – deblocking is automatically accompanied by an acoustic signal; 4) prior to restarting the face conveyer, which is done manually by the operator, a signal is automatically transmitted to all transmitter stations. The block and deblock commands prevail over the functions of conversation. The EZT-2 system consists of a stationary station, the required number of helmet stations, (including a power source), the power system, and an accumulator-type charging equipment (including a stand for 20 helmet stations). An antenna, having a combined receiver and transmitter function in which the speaking signal transmitted by the transmitter station is received by the stationary station and is simultaneously transmitted on the second frequency, can be

par évaporation jusqu'à saturation presque complète par les sels. Par évaporation plus poussée ou par refroidissement, les sels non-radioactifs les moins solubles de la solution se cristallisent; ces cristaux en suspension se séparent en sels cristallins et en solution mère de sels résiduels, dont l'uranium et le reste des éléments radioactifs. La solution mère est recyclée dans le processus principal de transformation, où l'uranium se précipite alors que les sels restant dans la solution servent à la préparation de l'agent d'éluion des échangeurs d'ions, ce qui permet de consommer moins d'acide que dans le procédé actuel. Le distillat du procédé d'épaississement des eaux usées est acheminé aux points de consommation d'eau de l'usine et peut remplacer l'eau provenant de l'extérieur. Après un dernier nettoyage par cristallisation répétée, le raffinage et le contrôle de la qualité, les sels cristallins séparés peuvent être utilisés par les industries de la cellulose, des peintures et teintures, du verre et des détergents. Faire parvenir vos demandes de renseignements à: M. Jan Volny, Section 26, Polytechna, Foreign Trade Corporation, Technical Cooperation Agency, Pranska 6, P.O. Box 834, 112 45 Praha 1, Tchécoslovaquie. Veuillez transmettre une copie de votre correspondance initiale à la: Division commerciale de l'Ambassade canadienne, Mickiewiczova 6, 125 33 Prague 6, Tchécoslovaquie.

EZT-2 Système de signalisation et de protection au front de taille – LF 00054

Une agence tchèque qui accorde des licences offre les droits de fabrication et de commercialisation au Canada d'un système de sécurité accrue au front de taille des mines de charbon en cas de l'explosion de gaz et d'écrasement. Ce système de signalisation par radio permet à tout travailleur d'arrêter le convoyeur du front de taille et, au besoin, de bloquer son fonctionnement. Grâce au raccordement à un transmetteur, il peut informer l'équipe de travail de tout danger et utiliser le système à des fins de sauvetage. Les caractéristiques du système: 1) raccordement à un transmetteur pour atteindre tous les travailleurs au front de taille et aux voies de transport sur une distance allant jusqu'à 1 km; 2) arrêt immédiat du convoyeur au front de taille ou autres machines d'exploitation minière grâce à la transmission d'un signal de blocage et du blocage de l'équipement; 3) le déblocage de l'équipement ne peut être effectué que par la personne qui l'a bloqué en transmettant le signal pertinent – le déblocage s'accompagne automatiquement d'un signal acoustique; 4) avant de remettre en marche le convoyeur au front de taille – une opération manuelle – un signal est automatiquement transmis à toutes les stations du transmetteur. Les fonctions de blocage et de déblocage ont la priorité sur la conversation. Le système EZT-2 comprend une station fixe, le nombre requis de postes de rechargement pour projecteurs de casques (y compris une source d'alimentation), le système d'alimentation et un chargeur de type accumulateur (y compris un poste de rechargement pour projecteurs de 20 casques). On peut construire une antenne servant à la fois de récepteur et de transmetteur qui permet à la station fixe de recevoir le signal (voix) qui passe par la station de transmission et qui est simultanément transmis

arranged by the use of a free conductor in the power cable feeding the working face, or by an independent cable terminating with an explosion-proof box. When using a special converter, the antenna can consist of any kind of insulated conductor installed in the working face. Address enquiries to: Mr. Jan Volny, Polytechna, Pranska 9, P.O. Box 834, 11245 Praha 1, Czechoslovakia. Please send a copy of your initial correspondence to: Commercial Division, Canadian Embassy, Mickiewiczova 6, 125 33 Prague 6, Czechoslovakia.

Self-Propelled Swing

American inventor offers his U.S. patent number 3,889,944 for sale or licensing to a Canadian manufacturing company. The patent covers a self-propelled swing which is hung on a horizontal support, can be directed by pressure and may be used indoors or outdoors by persons of any age. It can be used as a push toy but has been specifically designed for the young child who is unable to pump or propel himself, or for rehabilitation purposes. It has a specially made seat ensuring safety and stability. Address enquiries to: Mr. Salvatore Sapienza, 128 Commons Street, Lawrence, Massachusetts 01841. Please send a copy of your initial correspondence to: Canadian Consulate General, 500 Boylston Street, Boston, Massachusetts 02116.

sur la seconde fréquence en posant un conducteur libre dans le câble d'alimentation du front de taille ou à l'aide d'un câble indépendant avec boîte hermétique à l'extrémité. Si on utilise un adaptateur spécial, n'importe quelle sorte de conducteur muni d'un isolant installé dans le front de taille peut servir d'antenne. Adresser toute demande de renseignements à: M. Jan Volny, Polytechna, Pranska 9, C.P. 834, 11245 Praha 1, Tchécoslovaquie. Veuillez envoyer une copie de votre correspondance initiale à la Division commerciale, Ambassade du Canada, Mickiewiczova 6, 125 33 Prague 6, Tchécoslovaquie.

Balançoire auto-propulsée

Un inventeur américain offre de vendre ou de céder sous licence son brevet numéro 3 889 944 à une société de fabrication canadienne. Il s'agit d'une balançoire à auto-propulsion suspendue d'une barre horizontale, qui obéit à une poussée et qui peut être utilisée à l'intérieur comme à l'extérieur par des personnes de tous les âges. Cette balançoire peut servir aussi de jouet à poussée mais elle a été conçue spécialement pour l'enfant en bas âge qui ne peut se donner un élan ou une poussée, ou à des fins de réadaptation et est munie d'un siège assurant la sécurité et l'équilibre. Pour de plus amples renseignements, communiquer avec: M. Salvatore Sapienza, 128, rue Commons, Lawrence, Massachusetts 01841. Veuillez envoyer une copie de votre correspondance initiale au Consulat général du Canada, 500, rue Boylston, Boston, Massachusetts 02116.

RECENTLY ISSUED CANADIAN PATENT AVAILABLE FOR LICENSING OR SALE

Résumés of these patents are published in the language of application, English or French. If a copy of the full patent is required it may be obtained for \$2.00 from the Commissioner of Patents, Ottawa-Hull, Canada K1A 0C9.

BREVETS CANADIENS RÉCEMMENT ÉMIS À VENDRE OU OFFERTS SOUS LICENCE

Un résumé de l'invention est publié dans la langue de la demande de brevet, soit en anglais, soit en français. Les intéressés peuvent se procurer un exemplaire du brevet au prix de \$2.00 en écrivant au Commissaire des brevets, Ottawa-Hull, Canada K1A 0C9.

Sound Emitting Aerial Toy

1,055,703 Jouet aérien sonore

A toy comprising an elongate body designed to be held in the hand. A means responsive to the passing of air to produce a sound positioned at least one end of the elongate body and by throwing the body through the air produces a sound. Write: Wilbert A. Howie, 602 Thetis Place, Richmond, British Columbia, V7C 2N3

Belt Grinder

1,055,707 Ponceuse à courroie

A belt grinder which tilts from 90° to the horizontal to 45° permits grinding of the edge of plate glass and other similar material either orthogonal to the plate glass sheet or at any inclined angle to 45°. Write: Bee Metal Products Limited, 33 Fidler Avenue, Woodstock, Ontario, N4S 7J1

Alliage de plomb pour grille de plaque d'accumulateur

1,055,735 Lead Alloy for Battery Plate Screen

Alliage de plomb pauvre en antimoine pour grille de plaque d'accumulateur comprenant notamment du tellure dans une quantité en poids comprise de 0.001% et 0.2%, 1 à 3.5% d'antimoine, 0.01 à 0.2% d'arsenic, 0.005 à 0.05% d'étain et 0 à 0.3% d'argent. Écrire: Compagnie Européenne d'Accumulateurs, 16 rue de la Baume, 75008 Paris, France

Radiation Safety Shield Syringe**1,055,799 Écran protecteur contre les radiations**

A safety apparatus for use in administering radioactive serums by a syringe, without endangering the health and safety of the medical operators, consists of a sheath and a shield which can be retracted into the sheath to assay the radioactive serum in an assay well. The shield can be moved from the retracted position into an extended position when the serum is to be injected into the patient. To protect the operator, the shield can be constructed of tantalum or any like high density substance to attenuate the radiation, emanating from the radioactive serums contained in the syringe, from passing to the atmosphere. A lead glass window is provided so that the operator can determine the exact quantity of the radioactive serum which is contained in the syringe. Write: United States Department of Commerce, National Technical Information Service, 425 13th Street, N.W. Washington, D.C. 20004, U.S.A.

Process for Distillation and Purification of a Crude Alcohol Containing Mixture**1,055,875 Procédé pour la distillation et la purification d'un mélange contenant un alcool brut**

A crude alcohol-containing mixture comprising a saturated aliphatic alcohol of not more than 3 carbon atoms and associated impurities is processed to permit recovery of the desired alcohol product in highly concentrated and purified form. In a first extractive distillation tower the crude feed is subjected to extractive distillation with water to remove substantially all the impurities overhead. An aqueous bottoms stream from the first tower containing 5 to 10wt. % alcohol and only minor amounts of impurities is fed to a second rectifying tower where the alcohol product is concentrated and recovered. Stripped aqueous effluent is withdrawn from the bottom of the rectifying tower and is recycled in part to the first tower. An aqueous alkali solution is introduced into the rectifying tower and regulated so that the concentration of alkali in the stripped aqueous effluent from the bottom of the tower is from about 0.10 to about 0.24 gram per liter. Overhead and intermediate purge streams containing low boiling and high boiling impurities may be removed from the overhead from the first tower. The impurities are recovered as by-products from the third tower, and an alcohol stream is recycled from the third tower to the first tower. Write: Raphael Katzen Associates International, Inc., 1050 Delta Avenue, Cincinnati, Ohio 45208, U.S.A.

Electrolytic Cell**1,055,886 Cellule électrolytique**

A fixed, hollow, cylindrical, open ended electrically conductive cathode concentrically surrounds a hollow, cylindrical, electrically conductive anode. The anode is fixed upon an electrically conductive axle so as to allow the anode and axle to rotate inside the cathode. Electrically non-conductive brushes are mounted on the anode and rotate therewith, sweeping over the radially inner surface of the cathode. A water inlet housing at one end of the cathode and a water exhaust housing at the other end of the cathode cooperate to divert a stream of water in which salt has been dissolved between the anode and the cathode, the housing also supporting the conductive axle and allowing it to rotate. An electric motor rotates the axle. Write: Adrian Persson, 560 Ringsley Avenue, Palo Alto, California 94301, U.S.A.

Barrel Carrier**1,055,896 Transporteurs de barils**

The barrel carrier consists of upper and lower lip or rim engaging jaws formed on upper and lower support bars respectively. The two bars are telescopically connected together and can be detachably clamped in the desired position so that the jaws engage over the upper and lower rims of the barrel. The clamp bolts terminate in relatively large handles to facilitate the lifting of the barrel when the carrier is engaged thereon. Write: Henry W. Steiner, Box 18, Site 19, R.R. #1, Dryden, Ontario, P8N 2Y7

Stump Cutting and Precision Digging Apparatus**1,056,275 Dispositif essoucheur/excavateur de précision**

Realizing the shortcomings of known stump cutters, this invention provides a stump cutting/earth digging apparatus including a balanced, channel frame chassis medially supported by a pair of wheels which are independently mounted on vertically adjustable and horizontally telescopic axles. A combination belt and gear system provides drive means for a forward centrally disposed cutting wheel having a plurality of radially extending cutting teeth secured in an optimal configuration circumferentially on the cutting wheel. The instant apparatus also includes a unique rotationally adjustable and telescopic handle for accurate and easy control of the device. Write: Norman E. Shivers, (Jr.); David E. Shivers, 121 West E1 Segundo, Los Angeles, California 90061, U.S.A. and Paul N. Shivers, 424 East Foothill Boulevard, Apt. D, Monrovia, California 91610, U.S.A.

Graphic Arts T-Bar Razor**1,056,297 Rasoir à barre en T, utilisé en arts graphiques**

In this invention, the severing action of a 2000 r.p.m. motor driven circular razor, and the perfectly straight guidance of a fluorocarbon bearing carriage across a rigid traverse T-bar, set at a maintained height above a table platform, makes heavy cuts without twisting or skewing and without clamping. The design incorporates a slide that lifts and lowers to manipulate the

inside bevelling of matboard. Interchangeable with the razor arbor is a small diameter fine tooth saw arbor with an attachment for smooth cutting on thin paper. The motor switch is a press on, hold, and release stop action entirely favourable to the concept of non-clamping. Write: Robert Simpson, 25 Bay Mills Boulevard, Apartment 301, Scarborough, Ontario, M1T 3P4, Canada.

Bogie Positioning Device for Tractor/Trailer Units 1,056,414 **Dispositif pour positionner le bogie de tracteurs/remorques**

A bogie slide for re-positioning the rear wheels of a tractor trailer unit includes a carriage movably mounted on tracks for movement between stops. The trailer is backed onto the carriage, i.e., the rear wheels of the trailer are positioned on the carriage against a pair of wheel chocks, the pins holding the rear wheel bogies of the trailer are moved, and the trailer is moved with the carriage against one of the stops. As the trailer continues to move backwards, the wheels, bogies and carriage remain stationary, so that the wheels and bogie are moved forward along the base of the trailer. Write: Andrew M. Garford, 10755-164th Street, Edmonton, Alberta, T5P 3S1, Canada.

Cellule photothermogène 1,056,486 **Photothermogenic Cell**

L'invention concerne une cellule monolithique, dite photothermogène, pour la conversion d'énergie lumineuse en énergie calorifique. La cellule comporte une ou plusieurs cellules photoélectriques ou photovoltaïques capables de convertir cette énergie lumineuse en énergie électrique, des éléments résistifs reliant les électrodes de chaque cellule photoélectrique de sorte à convertir l'énergie électrique générée en énergie calorifique, et une enveloppe protectrice, transparente entourant à la fois la cellule photoélectrique et les éléments résistifs pour former un ensemble monolithique. Il est, en outre, décrit un ensemble de cellules photothermogènes reliées entre elles au moyen de contacts extérieurs prévus pour chaque cellule. Écrire: Alexis M. Brunet, 1980 Emmanuel, Laval, Québec, H7T 1J5, Canada.

Electric Tooth Polisher 1,056,563 **Polissoir électrique pour les dents**

Tooth polishing apparatus employs hand held electrically operated means and a polishing head impregnated with a liquid dentifrice rotated by the means. The head is placed in contact with the teeth to be cleaned. The head is generally conically shaped and porous. A shallow hollow cylinder containing dentifrice is secured to the base of the head with a discharge orifice communicating with the base of the head. Normally closed valve means disposed partially in the head and partially in the cylinder normally closes the orifice. When the head is inverted with the apex pointing downward and is pressed upward manually, the orifice is opened. The dentifrice then flows out of the orifice and into the head to impregnate it. Write: Frederick P. Spotteck, 63-59 75th Place, Middle Village, New York 11379, U.S.A.

Sulfonation Parameters Useful in Designing Miscellar Dispersions Useful in Oil Recovery Processes 1,056,589 **Paramètres de sulfonation utiles pour la conception de dispersions micellaires pour les procédés de récupération du pétrole**

A method of designing a micellar dispersion useful for oil recovery purposes is obtained by first establishing a lineal relationship between the aliphatic to aromatic proton (A/AP) ratio of the hydrocarbon portion of particular average equivalent weight petroleum sulfonates vs. the concentration of particular cosurfactants useful to stabilize the micellar dispersion, then using this relationship to design micellar dispersions. Petroleum sulfonates useful in the dispersions are those having average equivalent weights of 350-525 and which have A/AP ratios within the range of 4-20 moles per mole. Knowing the particular equivalent weight and A/AP ratio of the petroleum sulfonate, a cosurfactant can be chosen or vice versa. Preferably, the linear relationship is a semi-logarithmic plot. Write: Marathon Oil Company, 539 South Main Street, Findlay, Ohio 45840, U.S.A.

Procédé et dispositif de recyclage au carburateur de vapeurs d'hydrocarbures 1,056,671 **Method and Apparatus for Recycling Hydrocarbon Vapours in the Carburetor**

Dispositif de recyclage au carburateur des vapeurs d'hydrocarbures émises par un véhicule automobile du type comportant entre le réservoir et la goulotte reliant le filtre à air au carburateur un récipient d'absorption ou canister destiné à absorber ces vapeurs d'hydrocarbures. Ce dispositif est caractérisé par le fait que ledit canister, relié à une admission d'air sous pression provenant d'une pompe, comporte au droit de la paroi opposée au couvercle, paroi dans laquelle sont disposés l'orifice d'amenée d'air et l'orifice de sortie des gaz d'hydrocarbures et sensiblement à égale distance de ces derniers, une cloison ou chicane passant sensiblement par l'axe du canister et d'une longueur déterminée de manière à ne pas contrarier le passage des gaz tout en permettant un allongement de leur circuit de passage dans le canister, donc une utilisation totale de la masse d'absorption

y contenue. Écrire: Régie Nationale des Usines Renault, 8/10 Avenue Emile Zola, Boulogne-Billancourt, Hauts de Seine, France; Automobiles Peugeot, 75 Avenue de la Grande Armée, Paris, France

Catalytic Warmer or Heater

1,056,679 Réchaud ou chaufferette catalytique

The present invention provides a catalytic warmer or heater which may be made in different sizes and shapes. A chimney section top has an opening through which a heatable material container is insertable, and which rests on an X-frame supported on punched-in tongues providing draft apertures for the chimney, while a lower spaced series of punched-in tongues rest on a catalyst containing cage which, in turn, rests on a flange of fuel cartridge section below having a wick extending up from the cartridge to be lighted temporarily to initiate the catalytic combustion process. The supporting X-frame has a depending cylinder providing a snuffer to snuff out the wick and permit the catalytic combustion to continue. The catalytic combustion is stopped when desired by merely turning the entire heater or warmer upside down and then removing the fuel cartridge containing section, now on top, from the chimney section, now on bottom, the catalyst cage remaining with the chimney section and thus separated from the cartridge fuel section. Write: Alfred A. Rappaport, 2081 South Ocean Drive, Apt. 305, Hallandale, Florida 33009, U.S.A.

Blow Out Preventer

1,056,721 Obturateur anti-éruption

In oil and gas well pumping apparatus, a polish rod reciprocates through a stuffing box and connects to a submersible pump through a tubing string or the like. When servicing, it is desirable to close off the gas or oil pressure from below and hydraulic fluid is routed from a remote location to the blow out preventer. The blow out preventer consists of a cylindrical casing with a cap screw threadably engaged to the upper end thereof and containing a cylindrical spool or the like formed from elastomeric material having an annular channel around the outer perimeter which is operatively connected to the source of hydraulic fluid. When it is desired to close off the blow out preventer, hydraulic fluid is pumped under pressure to the channel thus forcing the center of the spool inwardly and clamping same around the polish rod thereby closing off the passageway around the polish rod. O rings surround the spool above and below the channel and assist in sealing. Upper and lower steps in the casing slope outwardly and away from one another to facilitate the return of the spool to the normal position when pressure is released. Write: Albert I. Bruce, 3003-505 - 4th Avenue S.W., Calgary, Alberta T2P 0J7

Wind Motors

1,056,732 Eoliennes

Wind motors which are propelled by the impact of wind against the vanes of an impeller wheel that travels in the same direction as the on-coming wind, that also has a wind channeling device that gathers the wind from a large area and funnels it at increased density, pressure, and speed, to apply multiplied impact against the wind motor impeller vanes. Write: Donald L. Sellman, 407 South 3rd Street, Lincoln, Kansas 67455, U.S.A.

Kitchen Cupboard Assemblies

1,056,895 Armoires de cuisine

A kitchen cupboard assembly has a lower floor mounted cupboard unit with an upper working surface and an upper wall mounted cupboard unit which is mountable thereabove. A frame is hinged about a horizontal axis between a lower position in which it rests on the working surface and a raised position in which it forms a front door of at least one cupboard of the upper cupboard unit. The upper surface of the frame is used to support an item of kitchen machinery such as a domestic mixer, or the like, and this is folded away into the upper cupboard when not in use. Write: Tore G. Palmaer, Smultronvägen 28, S-331 00 Värnamo, Sweden

Method and Apparatus for Separating Dispersed Matter from a Fluid Medium

1,056,901 Méthode et matériel de séparation des matières dispersées en milieu fluide

Herein are disclosed a method and apparatus whereby dispersed matter in the form of finely-divided particles, and/or in the form of molecular species such as molecules, atoms and radicals, are separated from a gaseous or liquid medium. A fluid medium containing dispersed matter is subjected to a field of a corona discharge from a first electrode (hereinafter referred to as a "separating electrode") which is pervious to the passage of the fluid medium and dispersed matter, whereby particles are charged if not already charged, and molecular species are ionized if not already ionized, in the same electrical polarity as that of the charge on the separating electrode, and the dispersed matter is selectively repelled by the influence of the field and electrode, and a fluid medium containing a consequently-reduced concentration of the dispersed matter is passed through the separating electrode and collected. The charged particles and/or ionized molecular species preferably are exposed to a second electrode (hereinafter referred to as a "collecting electrode"), preferably but not necessarily grounded, in order to facilitate the collection of the selectively-repelled dispersed matter. Write: George C. Yeh, Smedley Drive, R.D. #1, Newtown Square, Pennsylvania 19073, U.S.A.

Core Lamination for Shell-type Cores, Particularly for Transformers

1,056,924

Structure feuilletée pour noyaux cuirassés, tout particulièrement pour transformateurs

The invention concerns a transformer lamination having a center leg, two outer legs and two yokes connecting these legs and having at least one joint between one side of the center leg and the adjacent yoke. The characteristic feature is that the width of the jointlessly connecting yoke is greater than that of the parted yoke. In a preferred embodiment the sum of both yoke widths is roughly 1.35 times the center leg width. Write: Karl Philberth; Bernhard Philberth, c/o Father Prior Wilfred Sowerby, O.S.B., Westminster Abbey, Mission City, British Columbia, V2V 4J2

Core Lamination for Shell-type Cores, preferably for Transformers

1,056,925

Structure feuilletée pour noyaux cuirassés, de préférence pour transformateurs

The invention concerns a transformer lamination having a center leg, two outer legs and two yokes connecting these legs and having at least one joint between one side of the center leg and the adjacent yoke. Characteristic features are that the length of the joint at each side of the center axis is at least 0.75 times the center leg width and that the joint has at least one concave part and at least one convex part on at least one side of the center axis. A preferred embodiment contains two symmetrical joints, each of them comprising two sections which are parallel to the center axis and one section which is perpendicular to the center axis. Write: Karl Philberth; Bernhard Philberth, c/o Father Prior Wilfred Sowerby, O.S.B., Westminster Abbey, Mission City, British Columbia V2V 4J2

LICENSING OPPORTUNITIES FROM JAPAN

**PROCÉDÉS D'ORIGINE JAPONAISE EXPLOITABLES
SOUS LICENCE AU CANADA**

The following developments are offered for manufacture in Canada from the Research Development Corporation of Japan. Prospective Canadian licensees may obtain more detailed information from: Mr. Horoshi Ando, Manager, Department of Patent License, Research Development Corporation of Japan, 5-2 Nagato-Cho 2 Chome, Chiyoda-ky, Tokyo 100, Japan. Please send a copy of your initial correspondence to: Commercial Division, Embassy of Canada, 3-38 Akasaka 7 - Chome, Minato-ku, Tokyo 107, Japan.

Les procédés décrits ci-après sont présentés par la *Corporation de recherches sur le développement*, qui est une société japonaise, en vue d'être exploités éventuellement au Canada. Pour plus de précision, se renseigner auprès de M. Horoshi Ando, Directeur, Ministère des Brevets, Corporation de recherches sur le développement (Japon), 5-2 Nagato-cho 2 Chome, Chiyodo-ky, Tokyo 100, Japon. Prière d'expédier une copie de votre correspondance initiale à la: Division commerciale, Ambassade du Canada, 3-38 Akasaka 7 - Chome, Minato-ku, Tokyo 107, Japon.

Adipic Acid by Liquid-Phase Oxidation of Cyclohexane

JRDC 838

This technology relates to a production process of adipic acids characterized in that high purity products can be produced from cyclohexane by liquid-phase oxidation in one stage with high yield. The important point of this technology is the catalyst and reaction conditions to maintain the catalyst in an active condition. Advantages: Costs of raw materials are reduced by approximately 40% , as compared with the conventional two-stage oxidation method; the production process is much simpler than the conventional method and the plant construction costs can be drastically reduced (approximately 40%); the process is pollution-free because it requires no nitric acid and produces no NOx gas; reaction conditions are mild and the process is high in operating stability and safety; and, high purity products of the fiber grade can be obtained with high yield. Degree of development - Prototype stage.

Production d'acide adipique par oxydation en phase liquide du cyclohexane

JRDC 838

Cette technique décrit un procédé pour produire de l'acide adipique, très pur à partir du cyclohexane; le procédé comprend une oxydation en phase liquide en une étape, avec un rendement élevé. Le catalyseur utilisé et les conditions de réaction visant à le maintenir actif constituent les aspects importants de cette technique. Avantages: le coût des matières premières est réduit d'environ 40%, comparativement à la méthode ordinaire d'oxydation comportant deux étapes; le procédé est beaucoup plus simple et les coûts de construction de l'usine peuvent être considérablement réduits (environ 40%); le procédé ne pollue pas, étant donné qu'il n'utilise pas d'acide nitrique et ne produit pas d'oxydes d'azote; la réaction se produit dans des conditions peut rigoureuses et le procédé est très stable et très sûr; enfin, on peut obtenir des produits d'une grande pureté, avec un rendement élevé. Stade de développement - Prototype.

Apparatus for Removing Strain in IC Element by Vibration

JRDC 885

The generally known actions taken at the production site to solve the problem is to subject it to heat treatment by annealing at 125°C for 1,000 hours, and no other methods are known to release stress in such a thick-film integrated circuit. This technology eliminates the need of heat treatment which requires many hours. In this method, a moulded member is placed on the vibrating plate and is supported elastically so that the moulded member can be freely vibrated in the direction of vibration. By giving forced vibration of an appropriate frequency, the moulded member resonates on the vibration plate and this results in reducing, equalizing and stabilizing the uneven and great residual stress. This method is characterized in that the stress in IC can be removed by 30 minutes treatment at ambient temperature using simple vibrating equipment, unlike the conventional method which requires 1,000 hours treatment at 125°C using the annealing equipment and approximately 42 days for aging. Degree of development – Laboratory stage.

Chemicals Impregnated Capsule

JRDC 8330

This technology relates to a method of fixing chemicals such as vaporific medicine, oozing chemicals and exuding chemicals and others in special granular foamed silica, and the fixed chemicals are exposed to air so as to exhibit their effect gradually. For long-term and continuing effect of relatively expensive chemicals such as disinfectants, agricultural chemicals (insecticide, pasteurizing agent, herbicide, etc.), fertilizers and others, the capsule is formed by impregnating a nonpoisonous, odorless and lightweight inflammable granular material with these chemicals. This capsule is granular, and can be easily and conveniently handled by dissemination, burying or other method. Furthermore, the encapsulation adds degree of safety in handling harmful chemicals. In the case of sublimative chemicals, medicinal effects are delayed by a factor of 1.5 to 2.5; in the case of volatile chemicals, it is delayed by a factor of 2 to 5; and in the case of chemicals that dissolve in water and ooze out, it is delayed by a factor of 2 to 10. Furthermore, the capsule can be floated on the water and can be used for delayed chemical effects according to a variety of usages. Degree of development – Laboratory stage.

Efficient Checking of Coils and Transformers

JRDC 888

In the inspection of coils and transformers, inductance, Q value, turn ratio and other parameters have been measured individually. To shorten the inspection time and simplify the inspection procedure, this method employs an automatic Q meter equipped with a voltage control oscillator to automatically measure the Q value without tuning operation. It has also made it possible for a layman to measure the inductance of coils and the like by comparison with a standard

Appareil servant à éliminer, par vibration, la déformation dans un élément de circuit intégré (CI)

JRDC 885

A l'usine de fabrication, on résout généralement le problème en chauffant l'élément par recuit à une température de 125°C pendant 1 000 heures; on ne connaît pas d'autres méthodes pour éliminer les contraintes dans des circuits intégrés d'une telle épaisseur. Avec la présente technique, il n'est plus nécessaire de chauffer l'élément pendant si longtemps. L'élément moulé est placé sur la plaque vibrante maintenu par des supports élastiques de sorte qu'il puisse osciller librement dans la direction de la vibration. En appliquant une vibration forcée de fréquence appropriée, l'élément entre en résonance sur la plaque vibrante, ce qui a pour effet de réduire, corriger et stabiliser les fortes contraintes résiduelles irrégulières. Cette méthode permet d'éliminer la contrainte dans un CI en 30 minutes à la température ambiante, au moyen d'un simple appareil vibrant, alors que dans la méthode classique, il faut 1 000 heures de traitement à 125°C dans un four à recuire en plus de quelques 42 jours pour le vieillissement. Stade de développement – Laboratoire.

Capsules imprégnées de produits chimiques

JRDC 8330

La présente technique décrit un procédé de fixation de produits administrés par aérosol, de produits administrés par infiltration et autres produits, dans des granules de silice expansée; les produits fixés sont exposés à l'air afin qu'ils puissent se libérer graduellement. Pour des produits chimiques relativement dispendieux dont les effets sont de longue durée et continus, comme les désinfectants, les produits utilisés en agriculture (insecticides, agents de pasteurisation, herbicides, etc.), les engrais, etc., on prépare la capsule en imprégnant ces produits dans une matière granuleuse non toxique, inodore, légère et ininflammable. Cette capsule est granuleuse et peut être facilement appliquée par épandage, enfouissement ou par autres méthodes. De plus cette technique accroît la sécurité lorsqu'il s'agit des produits dangereux. Dans le cas des produits susceptibles de se sublimer les effets médicamenteux sont retardés par un facteur de 1.5 à 2.5; dans le cas des produits volatils, ce facteur est de 2 à 5; enfin dans le cas des produits qui sont solubles dans l'eau et qui peuvent s'infiltrer, le facteur varie de 2 à 10. De plus, la capsule peut flotter sur l'eau et peut être utilisée à retardement, selon les besoins. Stade de développement – Laboratoire.

Contrôle rapide et efficace des bobines et des transformateurs

JRDC 888

On mesure, lors du contrôle des bobines et des transformateurs, la valeur individuelle de l'inductance, du coefficient de surtension, du rapport de transformation, ainsi que d'autres paramètres. Afin de diminuer la durée du contrôle et de simplifier la méthode de mesure, on utilise un Q-mètre automatique muni d'un régulateur de tension; on peut ainsi mesurer automatiquement le coefficient de surtension sans

product using the impedance ratio deviation meter, instead of measuring absolute values thereof. Furthermore, it is provided with a turn ratio checker which permits deciding a turn ratio as well as a phase of the transformer accurately and rapidly. Thus the measurement time can be shortened to 1/3 to 1/10, as compared with the conventional inspection method. Degree of development – Pilot stage.

Electric Feeder Remote Controller

JRDC 887

This technology relates to a remote controller for electric feeders in the urban central sector where the load density is high and traffic is congested. Its features include the following: (1) Continuous monitoring of the operating condition of the distribution line. (2) Automatic detection of failure in the distribution line. (3) Test power transmission. (4) Separation of troubled section to be treated as a failure and control of locking operation. (5) Reduction of power loss caused by load changeover adjustment of high load density distribution lines. (6) Operations from (1) to (5) are remotely controlled by the operating mechanism of the system display panel in the central dispatching master station. Components of this equipment include (a) master station, (b) system display panel, (c) protector, (d) terminal station, (e) DM control box, (f) pallet terminal box, and others. Degree of development – Production stage.

Emergency Valve (Thermal Actuator)

JRDC 873

This emergency valve is constructed of a valve operation mechanism having a structure in which a thermal foamable plastics element is filled in an expandable container or a structure in which such a thermal foamable plastics element is filled in an actuator chamber such as a diaphragm, bellows, cylinder or the like. This valve is installed in the passage of an inflammable fluid (petroleum, municipal gas, etc.) to operate so as to shut off the passage by means of heat when the surrounding temperature increases abnormally in an explosion or fire or when the fluid itself is heated excessively. It can also be used as a releasing valve, for example, as a valve body of the emergency sprinkler head for fire, as well as for the boiler and the like to prevent being heated when empty and for releasing an excessively heated fluid. Unlike the conventional emergency valve which requires external power such as pneumatic pressure, hydraulic pressure or electric power, the structure can be simplified and costs are low. Degree of development – Prototype stage.

procéder à un réglage préalable. Cette méthode permet également à un non-spécialiste du domaine de mesurer l'inductance de bobines et d'éléments électroniques semblables, en comparant la mesure obtenue avec un étalon et en utilisant pour ce faire un impédancemètre; on évite ainsi de mesurer la valeur absolue. On utilise également un appareil de contrôle du rapport de transformation, ce qui permet de choisir exactement et rapidement une valeur appropriée pour le rapport de transformation et la phase du transformateur. On peut donc effectuer la mesure de 3 à 10 fois plus rapidement qu'avec la méthode classique de contrôle. Stade de développement – Pilote.

Dispositif de télécommande des lignes d'alimentation

JRDC 887

La présente technique décrit un dispositif de télécommande des lignes d'alimentation dans les centres-villes où la densité de charge est élevée et où le trafic électrique est intense. Il est constitué de: (1) un dispositif de surveillance continue de l'utilisation des lignes de distribution; (2) un dispositif de détection automatique des pannes dans les lignes; (3) un dispositif de vérification de la capacité de transport des lignes; (4) un dispositif d'isolement des secteurs où il y a une panne et un dispositif de surveillance des opérations de blocage; (5) un dispositif de diminution des pertes causées par la modification de charge apportée à des lignes de distribution de capacité de transport élevée; (6) les opérations de (1) à (5) sont télécommandées par le mécanisme actif du tableau d'affichage du poste principal. Cet équipement comprend: (a) poste principal; (b) tableau d'affichage; (c) disjoncteur; (d) poste satellite; (e) boîte de contrôle DM; (f) dispositif auxiliaire satellite et autres dispositifs. Stade de développement – Production.

Déclencheur d'urgence (thermosensible)

JRDC 873

Ce déclencheur d'urgence est constitué d'un mécanisme comportant une structure munie d'un contenant expansible ou d'une enceinte (diaphragme, soufflet, cylindre ou autre type d'enceinte) renfermant une matière plastique thermodilatable. On place le déclencheur à proximité d'une conduite contenant un produit inflammable (pétrole, gaz à eau, etc.). Ce déclencheur actionne la fermeture d'une vanne lorsque la température du milieu ambiant ou du produit dans la conduite devient anormalement élevée par suite d'explosion ou d'incendie. Ce déclencheur peut également être utilisé pour actionner un extincteur automatique. Il peut aussi servir dans les chaudières et les contenants semblables afin d'arrêter le chauffage lorsqu'ils sont vides ou de libérer tout gaz ou liquide porté à une température excessive. Contrairement aux déclencheurs classiques qui doivent être actionnés de l'extérieur (pression pneumatique, pression hydraulique ou électricité), celui-ci est complètement autonome, simple et peut coûteux. Stade de développement – Prototype.

Fluoro-Elastomer Synthesized by Radiation JRDC 8311

This technology relates to the production process of a new type of fluoro-elastomer using radiation. A vessel reactor is charged with tetrafluoroethylene and propylene up to 30 kg/cm² in the presence of water and emulsifier to be irradiated with gamma rays at 30 to 50°C while being stirred. Cobalt 60 is used as the gamma ray source, and the intensity of gamma rays in the order of 3x10⁵ rad/hr suffices for the requirement. Tetrafluoroethylene and propylene are copolymerized in the proportion of equal mol to obtain latex of alternating copolymer of high molecular weight. Salt is added to latex to aggregate it, thereby crude rubber being obtained. Carbon or other is added to it to obtain products by cross-linking by the normal chemical method or by radiation. Advantages: high thermal resistance and chemical resistance allow the material to be used in high temperature acids and alkali. This was impossible with the conventional fluororubber (as lining materials and pipe packings for chemical plants); the production process is much simplified because of unnecessary of catalyst addition and removal; and, since propylene is used in 50 mol% of raw material, product costs are lower than those of the conventional fluororubber. Degree of development – Pilot stage.

Heat Transfer Tube with Internal Spiral Grooves JRDC 8713

This technology relates to making fine spiral grooves by forging tube from outside with a grooved plug maintained inside the tube. It permits making tubes having V-shaped or U-shaped continuous internal spiral grooves or which depth is 0.02 to 0.2mm, pitch is 0.1 to 0.05mm and twist is 4 to 15° to the axis. These tubes improve the thermal conductivity by 1.5 to 3.0 times of that of a smooth surface when a fluid flowing in the tube is evaporating or condensing. Despite the high thermal conductivity, there is no change in the internal pressure loss. Advantages: the performance of heat exchangers for refrigerator and air conditioner can be enhanced by 10 to 20% by improving internal heat transformer; thereby the equipment size can be reduced or energy conservation can be made possible. Degree of development – Prototype stage.

Lightweight Heat-Insulating Cement Board JRDC 8326

Major components are Portland cement, foamed silica and mineral fiber. This cement board (1) makes work at the construction site easy and simple, permits riveting and cutting in the same manner as in the prior art and enhances work efficiency, (2) permits reduced water contents which increase in the compressive strength, because of the high fluidity of the foamed silica as the aggregate, (3) permits improvement in the waterproofness and heat insulating property by a factor of 4 in maximum as compared with the

Photosynthèse d'un fluoro-élastomère JRDC 8311

Cette technique décrit un procédé pour produire un nouveau type de fluoro-élastomère par photo-synthèse. Un réacteur est rempli de tétrafluoréthylène et de propylène jusqu'à une pression de 30 kg/cm² en présence d'eau et d'un émulsifiant; le contenu est agité et exposé à des rayons gamma à une température de 30 à 50°C. On utilise à cette fin une source constituée de cobalt 60 émettant 3 x 10⁵ rad/h. Le tétrafluoroéthylène et le propylène sont copolymérisés en proportion équimolaire pour produire un latex de poids moléculaire élevé et dont les unités monomériques alternent à tous les maillons. Un sel est ajouté au latex pour l'agréger, produisant ainsi un caoutchouc brut. On ajoute du carbone ou une autre substance afin d'obtenir des produits réticulés. La réticulation est réalisée suivant le processus chimique normal ou par irradiation. Avantages: la grande résistance thermique et la résis-chimique élevée permettent d'utiliser le matériau en milieux acides et alcalins à des températures élevées, ce qui est impossible avec les fluorocaoutchoucs ordinaires (utilisés comme revêtement et garniture des conduites des usines chimiques). Le procédé est très simplifiés, vu qu'il n'est pas nécessaire d'ajouter et d'enlever le catalyseur. Enfin, puisque le propylène constitue 50 mole % des matières premières, les coûts de production sont moindres que ceux des fluorocaoutchoucs ordinaires. Stade de développement – Pilote.

Tubes pour transfert thermique, présentant des rainures hélicoïdales internes JRDC 8713

La présente technique décrit un procédé pour fabriquer des tubes présentant de fines rainures hélicoïdales sur leur paroi interne, en forgeant le tube de l'extérieur mais en maintenant à l'intérieur un tampon cannelé. Ainsi, on peut réaliser des tubes présentant sur leur paroi interne des rainures continues, en forme de V ou de U, d'une profondeur variant de 0.02 à 2 mm, d'un pas de 0.1 à 0.05 mm, et disposées par rapport à l'axe suivant un angle variant de 4 à 15°. Ces tubes possèdent une conductivité thermique de 1.5 à 3.0 fois supérieure à celle de tubes dont la paroi interne est lisse et dans lesquels s'écoule un liquide qui s'évapore ou qui se condense. La perte de pression interne est nulle malgré la conductivité thermique élevée. Avantages: il est possible d'accroître le rendement des échangeurs de chaleur des réfrigérateurs et des climatiseurs par un facteur de 10-20% en améliorant le transfert thermique interne. Il est donc possible de réaliser des appareils plus petits et, partant, de diminuer la quantité d'énergie consommée. Stade de développement – Prototype.

Panneau en ciment, léger et isolant JRDC 8326

Les principaux composants sont le ciment portland, la silice expansée et les fibres minérales. Ce panneau (1) simplifie et facilite le travail sur les lieux de construction, peut être riveté et coupé comme les panneaux classiques et accroît l'efficacité; (2) présente une teneur moindre en eau, et ainsi une résistance accrue à la compression, en raison de la grande fluidité de la silice expansée utilisée comme agrégat; (3) permet d'améliorer l'étanchéité et les propriétés isolantes par un facteur de 4 au maximum, en comparaison à l'amiante ordinaire; (4) possède des propriétés ignifuges accrues et peut

conventional type of asbestos, (4) has improved fire resistance and is suitable for walls and ceilings in fire proof constructions, and (5) saves energy consumption when used for housing material because of its excellent heat insulating property. Degree of development – Prototype stage.

Lightweight Heat-Insulating Plastic Composite JRDC 8312

This technology relates to the production process of lightweight, heat-insulating synthetic resin composites. The weight of plastic molds can be reduced without impairing characteristics, by using foamed silica as a filler in synthetic resins such as polyester, epoxy resins, DAP resins or other and their mechanical strength and heat insulating property can be improved, depending on the mixing volume of the foamed silica. In particular, the following properties are improved: (1) bending elastic modulus, bending strength, (2) impact strength, and (3) flame retardation. Methods of molding for this plastic composite can be selected from compression molding, extrusion molding, injection molding, paste molding and others according to the form, fluidity characteristics and compressive strength of the foamed silica. The composite can be used as mechanical member for housings, walls, ducts, building materials for roofs, walls, heat insulation, etc., reinforced plastics for FRP cores, heat retention and insulating pipes, synthetic wood, lightweight marine buoys and others. It can also be used to create new materials by combining the composite as a core material with different materials or it can be combined with inorganic fiber to be effectively used as materials for electrical equipment. Degree of development – Pilot stage.

Method of Removing Residual Stress JRDC 886

In this technology, which offers an improved method to remove the disadvantage of "strain phenomena", one side of a work having a shape which permits easy resonance such as ring shape, plate shape or box shape is contacted to a vibration plate, the work being movably supported by elastic materials so as to allow free vibration in the direction of the longitudinal wave. By an appropriate frequency, the work is forcedly vibrated and resonance is caused to the work, thereby the uneven and intensive internal residual stress in the work being equalized and reduced. It takes about 40 minutes in case of the annealing for a very hard mechanical seal of 40 to 30mm in diameter and 3mm in thickness in 800°C hydrogen current. On the other hand, this method is so effective that only 15 seconds are required for removing stress with a frequency of 2,000 Hz at 11G, 5G, and 1G respectively at ambient temperature and permits treatment in the same degree as the heat treatment. Degree of development – Prototype stage.

être utilisé pour les murs et plafonds dans les constructions à l'épreuve des incendies; et (5) permet une économie d'énergie lorsqu'on l'utilise comme matériau de construction en raison de ses très bonnes propriétés isolantes. Stade de développement – Prototype.

Composite isolant et léger, en matière plastique JRDC 8312

Cette technique décrit une méthode pour produire des composites légers et isolants, en résines synthétiques. Il est possible de réduire le poids des moules sans pour autant diminuer les caractéristiques du produit fini. Pour ce faire, on utilise de la silice expansée comme matière de charge des résines synthétiques (polyesters, résines epoxydiques, résines – DAP ou autres résines), et on améliore ainsi leur résistance mécanique et leur capacité isolante, selon les proportions volumiques de silice ajoutée. Plus particulièrement, ce sont les caractéristiques suivantes qui sont améliorées: (1) module élastique de flexion (résistance à la flexion); (2) résistance aux chocs; et (3) ignifugation. Pour ce qui est des méthodes de moulage, on procède par moulage par compression, moulage par extrusion, moulage par injection, moulage en pâte ou autres types de moulage, selon la forme désirée du matériau fini et le libre écoulement et la résistance à la compression de la silice expansée. Le composite peut être employé comme élément structural dans les habitations, les murs, les conduites, les toitures, comme matériau isolant, comme éléments de renforcement de l'âme des composites en plastique, des isolants pour tuyaux, des bois synthétiques, dans les boues légères, etc. On peut aussi l'employer pour produire de nouveaux matériaux en ajoutant d'autres substances au matériau de l'âme. On peut également ajouter des fibres inorganiques et ainsi l'utiliser efficacement comme matériau électrique. Stade de développement – Pilote.

Méthode d'élimination des contraintes résiduelles JRDC 886

La présente technique constitue une méthode améliorée pour éliminer le "phénomène de déformation". L'un des côtés d'une pièce ayant une forme qui lui permet d'entrer facilement en résonance (par exemple forme annulaire, plate ou cubique) est mise en contact avec une plaque vibrante. La pièce est maintenue par des supports élastiques qui lui permettent d'osciller librement dans la direction de propagation de l'onde longitudinale. En appliquant une fréquence appropriée, la pièce entre en vibration forcée; il y a résonance et la forte contrainte résiduelle interne et irrégulière est alors corrigée et réduite. Pour un joint mécanique très dur, de 30 à 40 mm de diamètre et de 3 mm d'épaisseur, il faut, par procédé de recuit, un traitement d'environ 40 minutes dans un courant d'hydrogène à une température de 800°C. Par contre, la présente méthode est tellement efficace qu'il suffit, pour éliminer la contrainte, d'un traitement de 15 secondes à une fréquence de 2 000 Hz, à 11G, 5G et 1G, respectivement, à la température ambiante. Les résultats obtenus sont équivalents à ceux obtenus par chauffage. Stade de développement – Prototype.

Spherical Synthetic Resin Powder**JRDC 8313**

This invention relates to a method to pulverize resins containing or not containing pigments, additives, hardening agents, etc. (resin can be either thermoplastic or thermosetting one). The solution obtained by dissolving the aforementioned resin compound in a water soluble solvent such as acetone, methylethylketone, tetrahydrofuran or the like is sprayed into a granulating tank with a pressure nozzle. Inside the granulating tank, water is sprayed from the top in shower, and the inner wall surface of the tank is maintained in a wet condition with shower water. The sprayed solution is granulated in the tank, with the solvent being removed into water. Fine spherical particles can be obtained by filtering and drying it. Within the scope of this technology, similar fine particles can be obtained by spraying a resin solution into water filled in a tank. Advantages: improved crush dispersion of pigments, and coating with excellent gloss reflecting sharpness can be obtained; improved toning accuracy; low temperature curing paint can be produced with high efficiency and uniformity in product quality; and, pulverulent body thus obtained excels in fluidity and storage stability as well as in the grain size distribution. Degree of development – Pilot stage.

Poudre de résine sphérique synthétique**JRDC 8313**

Cette technique décrit un procédé de pulvérisation de résines pigmentées ou non pigmentées, contenant ou non des additifs, des agents de durcissement, etc. (il peut s'agir d'une résine thermoplastique ou thermodurcissable). La solution obtenue par dissolution de la résine dans un solvant soluble dans l'eau (comme acétone, méthyléthylcétone, tétrahydrofurane ou autre solvant semblable) est vaporisée sous pression dans un réservoir à granulation à l'aide d'un gicleur. L'eau est vaporisée dans le réservoir par le haut et la surface des parois internes est ainsi maintenue humide. La solution vaporisée est granulée dans le réservoir et le solvant est éliminé avec l'eau. De fines particules sphériques sont obtenues par filtrage et par séchage. A l'aide de cette technique, on peut aussi obtenir de fines particules en vaporisant une solution de résine dans un réservoir rempli d'eau. Avantages: on peut obtenir un accroissement de la dispersion des pigments et un revêtement d'un très bon brillant; précision accrue de mise à la teinte; des peintures pour séchage basse température peuvent être produites avec une efficacité et une uniformité élevées; enfin, la fluidité, la stabilité en cours de stockage et la distribution granulométrique des matières pulvérulentes ainsi obtenues sont très bonnes. Stade de développement – Pilote.

**UNITED STATES GOVERNMENT
INVENTIONS FOR LICENSING**

(U.S. Patents and Applications are
published in the English
language only.)

**INVENTIONS DU GOUVERNEMENT DES ETATS-UNIS
DEVANT FAIRE L'OBJET DE LICENCES**

(Seule la version anglaise traite des brevets américain
et de leurs applications).

Adjustable Spanner Wrench

The patent application relates to an adjustable spanner wrench and, more particularly, to an adjustable spanner wrench which is sturdy in design and provided with interchangeable tips for use in various applications. Write: Patent Appl. 928 493/WG, U.S. Department of the Interior, Branch of Patents, 18th and C Streets, N.W., Washington, D.C. 20240. Please send a copy of your initial correspondence to: Canadian Consulate, 3 Parkway Building, Suite 1310, Philadelphia, Pennsylvania 19102.

Clé réglable**Aircraft Landing Aid for Zero-Zero Visibility Landings**

An aircraft landing system which provides a pilot a perspective view of a runway on which he intends to land under zero visibility conditions is described. The system includes a multiplicity of microwave transmitters spaced at known intervals along both sides of a runway and a timing generator which causes the microwave transmitters to transmit in sequence. The aircraft contains a monopulse receiver which provides conventional azimuth angle video information to a CRT display and also provides range video information to a Y sweep generator. The latter Y sweep generator generates a sweep voltage for the Y axis of the CRT display which is of sufficient length to display all transmitted pulses from all microwave transmitters in sequence with the correct relative spacing between microwave transmitters. Write: Patent 4 101 893, U.S. Department of the Navy, Assistant Chief for Patents, The Office of Naval Research, Mailing Code: 302, Arlington, Virginia 22217. Please send a copy of your initial correspondence to: Canadian Consulate, 3 Parkway Building, Suite 1310, Philadelphia, Pennsylvania 19102.

Aide pour les atterrissages par visibilité nulle

An Improved Suspension System for a Wheel Rolling on a Flat Track.

Système de suspension amélioré pour une roue se déplaçant sur un rail plat

A suspension system is described which has particular utility as an azimuth bearing for large track-mounted antennas. The system comprises a wheel frame assembly including at least one uncrowned wheel connected in supporting relation with the assembly and adapted to be seated in rolling engagement with a flat track, a load supporting bed, and a number of flexural struts interconnecting the bed and the assembly. Each of the struts is disposed in an inclined plane passing through the center of the uncrowned wheel surface along the line, substantially bisecting the line of contact established between the wheel surface and the track surface, and is characterized by a modulus of elasticity sufficient for maintaining the axis of rotation for the wheel in substantial parallelism with the line of contact. Write: Patent Appl. 961 833/WG, Patent Counsel, NASA Resident Legal Office, Mail Code: 180-601, 4800 Oak Grove Drive, Pasadena, California 91103. Please send a copy of your initial correspondence to: Canadian Consulate General, 510 West Sixth Street, Los Angeles, California 90014.

An Optical Track Gage Measuring Device

Dispositif optique de mesure de l'écartement de rails

The invention is a system for measuring the gage of railroad tracks and includes a pair of sensor probes mounted a fixed distance apart on a wheeled vehicle traveling along two rails and each located in positions horizontally adjacent to one of the rails. Each of the probes retains spaced apart first and second collimated light sources that direct first and second light beams at incident angles against the inner surface of the adjacent rail head at points five-eighths of an inch from the top surface thereof. After reflection from the rail head the first and second beams produce images in an optical receiver also retained by the probe. A detector produces an output dependent upon the spacing between the first and second beam image centers which is in turn dependent upon the distance between the probe and the adjacent rail head. Thus, the measured distances provided by the two probes in addition to the fixed spacing therebetween establishes rail gage in a plane five-eighths of an inch below the top surfaces of the rails. Write: Patent Appl. 962 239/WG, U.S. Department of Transportation, Patent Counsel, 400-7th Street, S.W., Washington, D.C. 20590. Please send a copy of your initial correspondence to: Canadian Consulate, 3 Parkway Building, Suite 1310, Philadelphia, Pennsylvania 19102.

Antimicrobial Fatty Acid Derivatives

Dérivés antimicrobiens d'acides gras

Acetylthio amides and esters were prepared by the free radical addition of thiolacetic acid to the terminal and non-terminal double bonds of N-substituted fatty amides and fatty esters. These new sulfur or halogen-containing compounds were found to have antimicrobial activity and to possess properties making them useful as antimicrobial agents. Write to: Patent Appl. 904 644/WG, U.S. Department of Agriculture, Research Agreements and Patent Management Branch, General Services Division, Federal Building, Agricultural Research Service, Hyattsville, Maryland 20782. Please send a copy of your initial correspondence to: Canadian Consulate, 3 Parkway Building, Suite 1310, Philadelphia, Pennsylvania 19102.

Automated Clinical System for Chromosome Analysis

Système automatisé pour l'analyse clinique des chromosomes

An automatic chromosome analysis system is provided wherein a suitably prepared slide with chromosome spreads thereon is placed on the stage of an automated microscope. The automated microscope stage is computer operated to move the slide to enable detection of chromosome spreads on the slide. The X and Y location of each chromosome spread that is detected is stored. The computer measures the chromosomes in a spread, classifies them by group or by type and also prepares a digital karyotype image. The computer system can also prepare a patient report summarizing the result of the analysis and listing suspected abnormalities. Write: Patent 4 122 518. Patent Counsel, NASA Resident Legal Office, Mail Code: 180-601, 4800 Oak Grove Drive, Pasadena, California 91103. Please send a copy of your initial correspondence to: Canadian Consulate General, 510 West Sixth Street, Los Angeles, California 90014.

Catalyzing Cellulosic Textile Finishing Processes with Phosphonic Acid Derivatives

Catalyseurs aux dérivés de l'acide phosphonique pour les procédés de finition des textiles cellulosiques

Alkyl and aryl phosphonic acids and certain salts thereof have been found useful as catalysts for the chemical reactions involved in finishing cotton and other cellulosic textiles. These versatile catalysts can be employed in a variety of finishing treatments including dimensional stability, durable press, and flame resistance, and are operative under a diverse range of processing conditions. Write: Patent 4 080 480, U.S. Department of Agriculture, Research Agreements and Patent Management Branch, General Services Division, Federal Building, Agricultural Research Service, Hyattsville, Maryland 20782. Please send a copy of your initial correspondence to: Canadian Consulate, 3 Parkway Building, Suite 1310, Philadelphia, Pennsylvania 19102.

Chemiluminescent Warning Capsules**Capsules chimioluminescentes d'avertissement**

An air-reactive chemiluminescent formulation is encapsulated, and material which will catalyze the reaction of the formulation with air is affixed to the outside of the capsule. When the capsule is crushed, the formulation, air and the catalyst all come into contact with one other and high intensity light is produced rapidly. Write: Patent 4 089 797, U.S. Department of the Navy, Assistant Chief for Patents, The Office of Naval Research, Mailing Code: 302, Arlington, Virginia 22217. Please send a copy of your initial correspondence to: Canadian Consulate, 3 Parkway Building, Suite 1310, Philadelphia, Pennsylvania 19102.

Combuster**Chambre de combustion**

A combuster is provided for utilizing a combustible mixture containing fuel and air, to heat a load fluid such as water or air, in a manner that minimizes the formation of nitrogen oxide. The combustible mixture passes through a small diameter tube where the mixture is heated to its combustion temperature, while the load fluid flows past the outside of the tube to receive heat. The tube is of a diameter small enough that the combustible mixture cannot form a flame, and yet is not subject to wall quench, so that combustion occurs, but at a temperature less than under free flame conditions. Most of the heat required for heating the combustible mixture to its combustion temperature, is obtained from heat flow through the walls of the pipe to the mixture. Write: Patent 4 104 018, Patent Counsel, NASA Resident Legal Office, Mail Code: 180-601, 4800 Oak Grove Drive, Pasadena, California 91103. Please send a copy of your initial correspondence to: Canadian Consulate General, 510 West Sixth Street, Los Angeles, California 90014.

Cryogenic Expansion Joint for Large Superconducting Magnet Structures**Joint de dilatation cryogénique conçu pour les aimants supraconducteurs**

An expansion joint is provided that accommodates dimensional changes occurring during the cooldown and warmup of large cryogenic devices such as superconducting magnet coils. Flattened tubes containing a refrigerant such as gaseous nitrogen (N sub 2) are inserted into expansion spaces in the structure. The Gaseous N sub 2 is circulated under pressure and aids in the cooldown process while providing its primary function of accommodating differential thermal contraction and expansion in the structure. After lower temperatures are reached and the greater part of the contraction has occurred, the N sub 2 liquefies then solidifies to provide a completely rigid structure at the cryogenic operating temperature of the device. Write: Patent 4 066 496, Assistant General Counsel for Patents, Office of the General Counsel, U.S. Department of Energy, Washington, D.C. 20545. Please send a copy of your initial correspondence to: Canadian Consulate, 3 Parkway Building, Suite 1310, Philadelphia, Pennsylvania 19102.

Dewatering of Slimes**Déshydratation des vases**

Slimes, of the type treated according to the process of the invention, consist of aqueous suspensions of ultrafine solid materials. Due to the colloidal nature of the suspensions, separation of the solids therefrom is generally very difficult. Disposal of such suspensions in settling ponds is a common practice in many mineral beneficiation processes. This procedure, however, requires large retention ponds and very long settling periods, sometimes several years. Efficient dewatering of slimes is achieved by admixing the slimes with a flocculating agent, followed by mechanical manipulation to effect rapid removal of water and consolidation of solids. The required mechanical manipulation may be accomplished, e.g., by tumbling the mixture through a rotating cylindrical screen or by passing it across a vibrating screen. Write: Patent Appl. 923 837/WG, U.S. Department of the Interior, Branch of Patents, 18th and C Streets, N.W., Washington, D.C. 20240. Please send a copy of your initial correspondence to: Canadian Consulate, 3 Parkway Building, Suite 1310, Philadelphia, Pennsylvania 19102.

Electro-Optical Detector Protection Device**Dispositif de protection des détecteurs électro-optiques**

This invention relates to a field of optical apparatus and, more particularly, to apparatus for protecting an electro-optical detector used in a system for field diagnostic measurements of a continuous wave high energy laser beam. Electro-optical detectors are generally operated in conjunction with primary optical systems for gathering and focusing the reflected radiation from a desired 'target' or source, toward which the optical axis of the system is accordingly directed. In far field diagnostic measurements, a far field target is irradiated with a continuous high energy laser beam with a beam 'on' time from 3-30 seconds. The intensity pattern in the far field is thereafter mapped using electro-optical detectors. However, the intensity of the target radiation is generally of magnitude which, if unattenuated, can lead to detector failure or burnout. Write: Patent Appl. 859 354/WG, U.S. Department of the Navy, Assistant Chief for Patents, The Office of Naval Research, Mailing Code: 302, Arlington, Virginia 22217. Please send a copy of your initial correspondence to: Canadian Consulate, 3 Parkway Building, Suite 1310, Philadelphia, Pennsylvania 19102.

Furrow Opener and Apparatus for No-Tillage Transplanters and Planters

Semoir permettant de semer et de planter de jeunes plants en ouvrant des sillons sans travailler le sol

A new apparatus for opening furrows in soil is disclosed. Specifically, this apparatus consists of an opening mechanism, a closing mechanism, an automatic seed planting mechanism, an automatic seedling planting mechanism, a driving means, a towing means, and the salient component parts necessary to make them function. Write: Patent 4 090 456, U.S. Department of Agriculture, Research Agreements and Patent Management Branch, General Services Division, Federal Building, Agricultural Research Service, Hyattsville, Maryland 20782. Please send a copy of your initial correspondence to: Canadian Consulate, 3 Parkway Building, Suite 1310, Philadelphia, Pennsylvania 19102.

Hermetic Electrical Feedthrough for Aluminum

Raccord électrique étanche pour l'aluminium

A leak-tight joint between a Kovar ceramic feed-through and an aluminum housing is obtained by electron beam welding a short length of the outside surface of the Kovar cylindrical shell of the feedthrough to a region of nickel deposited on a thin wall cylindrical tube of aluminum formed in the aluminum housing. Write: Patent Appl. 921 138/WG, U.S. Department of the Air Force, AF/JACP, Washington, D.C. 20314. Please send a copy of your initial correspondence to: Canadian Consulate, 3 Parkway Building, Suite 1310, Philadelphia, Pennsylvania 19102.

High Range Resolution Radar Rate Aided Range Tracker

Dispositif de poursuite en distance aidé par radar à pouvoir séparateur élevé pour grande distance

This patent application discusses means for enabling a high range resolution radar to maintain precise range information of a high velocity maneuvering aircraft or other target during radar operation. A voltage indicative of target motion is provided as an input to a voltage controlled oscillator that develops a waveform having a frequency that varies from the frequency of a stable reference oscillator by an amount commensurate with that voltage input. The frequency differential of the two oscillators is utilized to cause the tracking window to move in proportion to the range rate of the target. Write: Patent Appl. 944 667/WG, U.S. Department of the Navy, Assistant Chief for Patents, The Office of Naval Research, Mailing Code: 302, Arlington, Virginia 22217. Please send a copy of your initial correspondence to: Canadian Consulate, 3 Parkway Building, Suite 1310, Philadelphia, Pennsylvania 19102.

Hydrometallurgical Extraction of Tungsten from Refractory Tungsten Ores

Extraction hydrométallurgique du tungstène à partir de minerais de tungstène réfractaires

A process is described for recovering tungsten from refractory tungsten ores, comprising calcining, rapidly quenching, and leaching the ores. A very high percentage of the tungsten may be extracted by this process. Write: Patent Appl. 912 264/WG, U.S. Department of the Interior, Branch of Patents, 18th and C Streets, N.W., Washington, D.C. 20240. Please send a copy of your initial correspondence to: Canadian Consulate, 3 Parkway Building, Suite 1310, Philadelphia, Pennsylvania 19102.

Mechanical Shaker Assembly for Continuous Harvesting of Fruit

Machine à secouage pour la récolte continue de fruits

The patent application concerns a mechanical shaker assembly adapted for use with an over-the-row power frame for the continuous harvesting of horticultural crops. It uniquely combines oscillating sway bars for dislodging the crops with a pendulum system for absorbing vibrations otherwise transmitted to the power frame by the sway bars. Write: Patent Appl. 945 954/WG, U.S. Department of Agriculture, Research Agreements and Patent Management Branch, General Services Division, Federal Building, Agricultural Research Service, Hyattsville, Maryland 20782. Please send a copy of your initial correspondence to: Canadian Consulate, 3 Parkway Building, Suite 1310, Philadelphia, Pennsylvania 19102.

Method of and Apparatus for Non-Destructively Testing Concrete.

Méthode et appareil d'essais non destructifs du béton

The patent application relates generally to methods of, and apparatus for, testing concrete, and more particularly, to a method of and apparatus for non-destructively testing concrete by impacting the concrete and monitoring induced vibrational energy using a triangular array of transducers equispaced from the point of impact. Write: Patent Appl. 931 069/WG, U.S. Department of the Interior, Branch of Patents, 18th and C Streets, N.W., Washington, D.C. 20240. Please send a copy of your initial correspondence to: Canadian Consulate, 3 Parkway Building, Suite 1310, Philadelphia, Pennsylvania 19102.

Method for Making an Aluminum or Copper Substrate Panel for Selective Absorption of Solar Energy.

Méthode de fabrication d'un panneau à substrat d'aluminium ou de cuivre pour l'absorption sélective de l'énergie solaire

A panel is described for selectively absorbing solar energy comprising an aluminum substrate. A zinc layer was covered by a layer of nickel and an outer layer of solar energy absorbing nickel oxide or a copper substrate with a nickel layer. A layer of solar energy absorbing nickel oxide distal from the copper substrate was included. A method for making these panels is disclosed. Write: Patent 4 104 134, Marshall Space Flight Center, Mail Code: CC01, Huntsville, Alabama 35812. Please send a copy of your initial correspondence to: Canadian Consulate General, 900 Coastal States Building, 260 Peachtree Street, Atlanta, Georgia 30303.

Method for Using Geothermal Energy

Méthode pour utiliser l'énergie géothermique

Geothermal energy is used to provide the temperatures and pressure necessary for catalytic conversion of carbon monoxide and hydrogen to methanol by lowering the reaction chamber into a geothermal well, or by otherwise using geothermal fluids to supply heat and pressure to the reaction chamber. Write: Patent 4 085 795, U.S. Department of the Navy, Assistant Chief for Patents, The Office of Naval Research, Mailing Code: 302, Arlington, Virginia 22217. Please send a copy of your initial correspondence to: Canadian Consulate, 3 Parkway Building, Suite 1310, Philadelphia, Pennsylvania 19102.

Microwave Power Transmission Beam Safety System

Dispositif de sécurité pour faisceaux de transmission par micro-ondes

Electromagnetic, wireless power transmission systems are presented. More particularly, apparatus and methods are provided for controlling an electromagnetic transmission beam in accordance with power distribution profiles which are altered by an object entering the beam. One application of the invention would be in transmitting high-power microwave energy from a spacecraft to a ground station, the beam being reshaped, dimmed, or doused in accordance with characteristics of objects entering the beam. The novelty of the invention lies in the use of a power profile sensing means to control an electromagnetic power beam by comparing power profiles experienced by radiation-receiving elements of the system and predetermined power profiles. Write: Patent Appl. Patent Counsel, NASA Resident Legal Office, Mail Code: 180-601, 4800 Oak Grove Drive, Pasadena, California 91103. Please send a copy of your initial correspondence to: Canadian Consulate General, 510 West Sixth Street, Los Angeles, California 90014.

Multi-Access Memory Module for Data Processing Systems

Module de mémoire à accès multiple pour systèmes de traitement de données

A memory apparatus is described for use in a data processing system which includes in its entirety a number of multi-access modules, each formed of a plurality of data bit cells. Each module is accessed through multiple independent channels and each channel is capable of servicing a different request during the same memory cycle. Structurally, each independent channel is coupled by a drive line to a data bit storage cell and each drive line is energizable to close a switch mechanism for connecting a read-write bit line circuit to the cell. Individual cells have their own independent bit line circuits and switch mechanisms. Thus, plural requests for a read-out of a single cell can be serviced simultaneously. Special circuitry is suggested for resolving conflicts arising in situations involving simultaneous read-write or write requests addressed to a single cell. Write: Patent 4 104 719, U.S. Department of the Navy, Assistant Chief for Patents, The Office of Naval Research, Mailing Code: 302, Arlington, Virginia 22217. Please send a copy of your initial correspondence to: Canadian Consulate, 3 Parkway Building, Suite 1310, Philadelphia, Pennsylvania 19102.

Non-Tracking Solar Energy Collector System

Système de collecteurs d'énergie solaire sans poursuite

A solar energy collector system is described. It is characterized by an improved concentrator for directing incident rays of solar energy on parallel strip-like segments of a flatplate receiver. Individually mounted reflector modules of a common asymmetrical triangular cross-sectional configuration supported for independent orientation are asymmetric included with vee-trough concentrators for deflecting incident solar energy toward the receiver. Write to: Patent 4 122 833, Patent Counsel, NASA Resident Legal Office, Mail Code: 180-601, 4800 Oak Grove Drive, Pasadena, California 91103. Please send a copy of your initial correspondence to: Canadian Consulate General, 510 West Sixth Street, Los Angeles, California 90014.

Nozzle Extraction Process and Handlemeter for Measuring Handle.

Méthode d'extraction par buse et dispositif de mesure pour l'évaluation de la tenue

A method and an apparatus for quantitatively measuring the handle of fabrics and other flexible materials are presented. Handle is that term used to refer to the qualities of drapability, flexibility, compressibility, foldability, stretchability, pliability, etc., possessed by fabrics and other flexible materials. In the present invention the handle of a material sample is quantified by measuring the force required to draw the sample through an orifice and expressing the resultant extractive force as a function of test apparatus geometry and the amount of sample drawn through the orifice to arrive at quantitative measure of handle, to be defined as handle modulus, for the sample in question. Write: Patent 4 103 550, Langley Research Center, Mail Code: 313, Hampton, Virginia 23665. Please send a copy of your initial correspondence to: Canadian Consulate, 3 Parkway Building, Suite 1310, Philadelphia, Pennsylvania 19102.

Optical Switch

Coupleur optique

An optical switch affords the selective coupling of any of a plurality of input light signals to any of a plurality of optical output paths. A first plurality of ports circumferentially disposed in a first common plane supports means for transmitting and/or receiving optical signals. A second plurality of ports similarly circumferentially disposed in a second common plane having the same central axis as the first common plane, supports means for transmitting and/or receiving optical signals. A rotatable assembly is mounted on a common support structure with the input and output ports and has first and second members which are independently movable about the central axis. A length of flexible fiber optic bundle has one end supported by a radial arm of the first rotatable member of alignment with a selected one of the first plurality of ports and the other end of the flexible fiber optic bundle is supported by a radial arm of the second rotatable member for alignment with any one of the second plurality of ports. The input and output ports are adapted to receive the terminal end of fiber optic cables, electro-optic transducers, or photo-responsive transducers as desired. Write: Patent 4 088 387, U.S. Department of the Navy, Assistant Chief for Patents, The Office of Naval Research, Mailing Code: 302, Arlington, Virginia 22217. Please send a copy of your initial correspondence to: Canadian Consulate, 3 Parkway Building, Suite 1310, Philadelphia, Pennsylvania 19102.

Pilot Valve Control Apparatus with Low Frequency Surge Suppression

Soupape pilote de commande anti-bélier de basses fréquences

The invention relates to a pilot valve control apparatus and, more particularly, to a pilot valve control apparatus used in a fluid pressure regulation system to suppress the effect of low frequency pressures surges. Write: Patent Appl. 933 693/WG, U.S. Department of the Interior, Branch of Patents, 18th and C Streets, N.W., Washington, D.C. 20240. Please send a copy of your initial correspondence to: Canadian Consulate, 3 Parkway Building, Suite 1310, Philadelphia, Pennsylvania 19102.

Porous Ceramic Tubing for Flowing Gas Lasers

Tube en céramique poreuse pour lasers à gaz

Porous ceramic materials are used for the walls of tubing for flowing gas lasers. Analysis of the gas flow shows that the axial pressure variation in the porous wall tubes is more gradual than for dense wall tubes leading to more uniform gain conditions. The saturation intensity is more uniform not only due to the reduced pressure anisotropy but also, at higher flow rates, because of axially varying particle dwell times in the discharge region. Write: Patent 4 091 133, U.S. Department of the Army, Judge Advocate General, Patent Division, R2C 455, The Pentagon, Washington, D.C. 20310. Please send a copy of your initial correspondence to: Canadian Consulate, 3 Parkway Building, Suite 1310, Philadelphia, Pennsylvania 19102.

Portable Device and Method for Determining Permeability Characteristics of Earth Formations

Appareil portatif et technique permettant de déterminer la perméabilité de formations de surface

The invention is directed to a device which is used for determining permeability characteristics of earth formations at the surface thereof. The determination of the maximum permeability direction and the magnitude of permeability are achieved by employing a device comprising a housing having a central fluid-injection port surrounded by a plurality of spaced-apart fluid flow and pressure monitoring ports radially extending from the central injection port. With the housing resting on the earth formation in a relatively fluid-tight manner as provided by an elastomeric pad disposed therebetween, fluid is injected through the central port into the earth formation and into registry with the fluid-monitoring ports disposed about the injection port. The fluid-monitoring ports are selectively opened and the flow of the fluid through the various fluid ports is measured so as to provide a measurement of flow rates and pressure distribution about the center hole which is indicative on the earth formation permeability direction and magnitude. For example, the azimuthal direction of the fluid-monitoring ports in the direction through

which the greatest amount of injected fluid flows as determined by the lowest pressure distribution corresponds to the direction of maximum permeability in the earth formation. Write: Patent 4 052 885, Assistant General Counsel for Patents, Office of the General Counsel, U.S. Department of Energy, Washington, D.C. 20545. Please send a copy of your initial correspondence to: Canadian Consulate, 3 Parkway Building, Suite 1310, Philadelphia, Pennsylvania 19102.

Portable Punch and Die Jig

Gabarit de perçage portatif pour poinçon et matrice

The portable punch and die jig includes a U-shape jig of predetermined width, has a slot of predetermined width in the base thereof extending completely across the width of the jig adapted to fit over the walls of rectangular tubes, and a punch and die assembly disposed in a hole extending through the base of the jig communicating with the slot in the base of the jig for punching a hole in the walls of the rectangular tubes at precisely determined locations. Write: Patent 4 065 853, Assistant General Counsel for Patents, Office of the General Counsel, U.S. Department of Energy, Washington, D.C. 20545. Please send a copy of your initial correspondence to: Canadian Consulate, 3 Parkway Building, Suite 1310, Philadelphia, Pennsylvania 19102.

Preparation of Ceramics

Préparation de céramiques

This patent describes a method for preparing ceramic material from a polymer which comprises selecting a polymer from the class consisting of poly(diorganosilanes), poly(haloorganosilanes), poly(carbosilanes), polysilazanes, polycarbocboranes, and polyborazines; heating said polymer to a temperature from 700 to 2000 C at a rate of at most 100 C/hr. in an inert atmosphere for at least one hour; and cooling to room temperature at a cooling rate which avoids thermal stresses. Write: Patent 4 097 294, U.S. Department of the Navy, Assistant Chief for Patents, The Office of Naval Research, Mailing Code: 302, Arlington, Virginia 22217. Please send a copy of your initial correspondence to: Canadian Consulate, 3 Parkway Building, Suite 1310, Philadelphia, Pennsylvania 19102.

Pulse Width Modulated Power Amplifier for Direct Current Motor Control.

Amplificateur de puissance à modulation par durée d'impulsion

This patent application describes a solid state electronic circuit for controlling a reversible direct current motor from a voltage source such that it may be rotated in either direction. The reversible direct current motor is connected into a bridge circuit with semiconductor switching elements which provide that the full supply voltage is available for starting in either direction. A pair of comparators receives input signals from a triangular wave generator and a signal source and in conjunction with a cross-fire protection circuit generates the drive pulses which control the semiconductor switching elements. Write: Patent Appl. 945 989/WG, U.S. Department of the Navy, Assistant Chief for Patents, The Office of Naval Research, Mailing Code: 302, Arlington, Virginia 22217. Please send a copy of your initial correspondence to: Canadian Consulate, 3 Parkway Building, Suite 1310, Philadelphia, Pennsylvania 19102.

Pump Lock-up Power Transmission

Transmission à accouplement hydraulique

The patent describes a power transmission providing cushioned shock-absorption power flow from a drive member to a driven member. The transmission includes a gear pump wherein both the gear and gear housing are free to rotate: the transmission also includes a recirculation flow path from the pump outlet to the pump inlet, said flow path comprising a metering valve that responds to pump outlet chamber pressure for progressively throttling the flow as the outlet chamber pressure rises. As the recirculation flow is throttled the pump gear and pump housing gradually lock together and thereafter rotate at approximately the same speed. Write: Patent 4 091 901, U.S. Department of the Army, Judge Advocate General, Patent Division, R2C 455, The Pentagon, Washington, D.C. 20310. Please send a copy of your correspondence to: Canadian Consulate, 3 Parkway Building, Suite 1310, Philadelphia, Pennsylvania 19102.

Remote Controlled Safety Hook

Crochet de sûreté actionné à distance

A hoist line hook is provided with a spring biased safety gate and further provided with a remote operating device for the safety gate. The gate operating device comprises a tension cable (swivelly attached) to the safety gate with the cable extending through a hole in the shank of the hook: the opposite end of the cable is attached to a tagline for remotely opening the safety gate of the hook. Write: Patent Appl. 955 434/WG, U.S. Department of the Navy, Assistant Chief for Patents, The Office of Naval Research, Mailing Code: 302, Arlington, Virginia 22217. Please send a copy of your initial correspondence to: Canadian Consulate, 3 Parkway Building, Suite 1310, Philadelphia, Pennsylvania 19102.

Sealant-Primer Coating**Apprêt d'étanchéité**

The coating, which is both a flexible sealant and a corrosion-inhibitive primer, can be used to protect the exterior skin and fastener patterns of high performance aircraft at low temperatures. The coating includes corrosion inhibitive pigmentation, resins, a curing agent, and a solvent blend permitting spray application of the coating. The two resins included in the coating are a reaction product of an epichlorohydrin and bisphenol A plus a polyurethane elastomer which is a reaction product of an aromatic isocyanate and a polyether glycol. The curing agent is a blocked diamine, i.e., a ketimine. The ketimine can be prepared by reacting a carbonyl compound and an aromatic diamine. Water is produced in this reaction. The reaction is reversible, so that as the ketimine absorbs atmospheric moisture, the aromatic diamine is released and in turn cures or cross-links the resins. The mixture of pigmentation, resins, ketimine, and solvent blend is a sprayable material that can be readily applied to surface using conventional spray equipment. After application, as the diamine is released, the coating is cured to a tough weather-resistant film. When utilized to protect exterior surfaces, a durable exterior coating can then be applied over the flexible sealant-primer to obtain a two-coat, all weather protective paint system. Write: Patent 4 101 497, U.S. Department of the Navy, Assistant Chief for Patents, The Office of Naval Research, Mailing Code: 302, Arlington, Virginia 22217. Please send a copy of your initial correspondence to: Canadian Consulate, 3 Parkway Building, Suite 1310, Philadelphia, Pennsylvania 19102.

Simultaneous Treatment of SO₂ Containing Stack Gases and Waste Water**Traitement simultané des gaz brûlés contenant du SO₂ et des eaux usées**

A process is described for simultaneously removing sulfur dioxide from stack gases and the like, and for purifying waste water such as derived from domestic sewage. A portion of the gas stream and a portion of the waste water, the latter containing dissolved iron and having an acidic pH, are contacted in a closed loop gas-liquid scrubbing zone to effect absorption of the sulfur dioxide into the waste water. A second portion of the gas stream and a second portion of the waste water are controlled in an open loop gas-liquid scrubbing zone. The second portion of the waste water contains a lesser amount of iron than the first portion of the waste water. Contacting in the open loop scrubbing zone is sufficient to acidify the waste water which is then treated to remove solids originally present. Write: Patent 4 123 355, Lyndon B. Johnson Space Center, Mail Code: AM, Houston, Texas 77058. Please send a copy of your initial correspondence to: Canadian Consulate, 2001 Bryan Tower, Suite 1600, Dallas, Texas 75201.

Smokestack-Mounted Airfoil**Défecteurs pour cheminée**

A system for improving the effluent dispersal characteristics of smokestacks subject to relative winds, comprising a vortex generating airfoil attached to a smokestack near the stack gas exit, is described. Relative winds passing over the airfoil create strong vortices which entrain and hold together smokestack effluents until the vortices deteriorate. The vortex flow direction and angle of ascension is controlled in order to achieve optimum effluent dispersal by varying the airfoil angle of attack. Write: Patent 4 099 452, Langley Research Center, Mail Code: 313, Hampton, Virginia 23665. Please send a copy of your initial correspondence to: Canadian Consulate, 3 Parkway Building, Suite 1310, Philadelphia, Pennsylvania 19102.

Solar Cell Collector and Method for Producing Same**Collecteur de cellule solaire et méthode pour le produire**

A transparent, conductive collector layer containing conductive metal channels is formed as a layer on a photovoltaic substrate by coating a photovoltaic substrate with a conductive mixed metal layer. A heat sink having portions protruding from one of its surfaces is attached. These protruding portions define a continuous pattern in combination with recessed regions among them such that they are in contact with the conductive layer of the photovoltaic substrate. Heating the substrate while simultaneously oxidizing the portions of the conductive layer exposed to a gaseous oxidizing substance forced into the recessed regions of the heat sink, creates a transparent metal oxide layer on the substrate. A continuous pattern of highly conductive metal channels is contained in the metal oxide layer. Write: Patent 4 122 214, Lewis Research Center, Mail Code: 500-113, 21000 Brookpark Road, Cleveland, Ohio 44135. Please send a copy of your initial correspondence to: Canadian Consulate, Illuminating Building, 55 Public Square, Cleveland, Ohio 44113.

Solar Cells Having Integral Collector Grids**Cellules solaires présentant des grilles de collection intégrales**

A heterojunction or Schottky barrier photovoltaic device is described, comprising a conductive base metal layer. A back surface field region was formed at the interface between the device and the base metal layer, a transparent, conductive mixed metal oxide layer in integral contact with the n-type layer of the heterojunction or Schottky barrier device. A metal alloy grid network was included. An insulating layer prevented electrical contact between the conductive metal base layer and the transparent,

conductive metal oxide layer. Write: Patent 4 104 084, Lewis Research Center, Mail Code: 500-113, 21000 Brookpark Road, Cleveland, Ohio 44135. Please send a copy of your initial correspondence to: Canadian Consulate, Illuminating Building, 55 Public Square, Cleveland, Ohio 44113.

Stirring Paddle

Palette de brassage

The patent application describes stirring paddle for circulating a liquid without splashing has a central relatively short right circular cylinder, a paddle portion extending downward from one face of the cylinder for stirring the liquid and a stem extending upward from the other face of the cylinder along the longitudinal axis, having an upper end adapted for attachment to means for rotating the stirring paddle. The paddle is particularly suitable for circulating liquids in a container in any situation where a loss of liquid would be detrimental. Write: Patent Appl. 821 869/WG, Assistant General Counsel for Patents, Office of the General Counsel, U.S. Department of Energy, Washington, D.C. 20545. Please send a copy of your initial correspondence to: Canadian Consulate, 3 Parkway Building, Suite 1310, Philadelphia, Pennsylvania 19102.

Strain Actuated Hydraulic Holdback Bar

Barre de retenue hydraulique à traction

The patent concerns a holdback bar for temporarily restraining an aircraft against the combined forces of engine thrust and catapult force prior to a catapult assisted launch of the aircraft which utilizes strain of a mechanical component to measure the level of combined forces. Housing stretch beyond a pre-determined amount actuates a floating trigger rod to lift a valve from its seat and permit escape of hydraulic fluid from a pressure chamber. The holdback bar includes a compensator for absorbing fluid volume changes caused by thermal expansion or contraction of the hydraulic fluid, and a rupture disk for limiting the pressure obtainable within the hydraulic fluid pressure chamber. Write: Patent 4 101 098, U.S. Department of the Navy, Assistant Chief for Patents, The Office of Naval Research, Mailing Code: 302, Arlington, Virginia 22217. Please send a copy of your initial correspondence to: Canadian Consulate, 3 Parkway Building, Suite 1310, Philadelphia, Pennsylvania 19102.

Treatment of Cured Meat Products

Traitement des viandes salées ou fumées

This invention pertains to a treatment of cured meat products to reduce their water activities to a level below 0.92 to produce a product which does not permit the growth of *Clostridium botulinum*. Cured meat products which do not permit the growth of *Clostridium botulinum* are produced without the addition of nitrite or other substances. Write: Patent Appl. 891 998/WG, U.S. Department of Agriculture, Research Agreements and Patent Management Branch, General Services Division, Federal Building, Agricultural Research Service, Hyattsville, Maryland 20782. Please send a copy of your initial correspondence to: Canadian Consulate, 3 Parkway Building, Suite 1310, Philadelphia, Pennsylvania 19102.

Ultrasonic Technique for Characterizing Skin Burns

Technique ultrasonique pour reconnaître les brûlures cutanées

This invention, a method for ultrasonically determining the depth of a skin burn, is based on the finding that the acoustical impedance of burned tissue differs sufficiently from that of live tissue to permit ultrasonic detection of the interface between the burn and the underlying unburned tissue. The method is simple, rapid, and accurate. As compared with conventional practice, it provides the important advantage of permitting much earlier determination of whether a burn is of the first, second, or third degree. In the case of severe burns, the usual two - to three-week delay before surgery may be reduced to about 3 days or less. Write: Patent 4 080 960, Assistant General Counsel for Patents, Office of the General Counsel, U.S. Department of Energy, Washington, D.C. 20545. Please send a copy of your initial correspondence to: Canadian Consulate, 3 Parkway Building, Suite 1310, Philadelphia, Pennsylvania 19102.

Wet-Wall Electroinertial Air Cleaner

Nettoyeur d'air électroinertiel à paroi humide

An apparatus to efficiently remove dust from air is disclosed. The apparatus comprises in combination an inertial unit and a concentric wire-in-tube precipitator, consisting of a thin charging wire located coaxially in a cylindrical vertical tube whose etched walls are continuously flushed with water. Thus, a continuous stream of dust laden air blown rotationally into the tube is electrostatically charged, and cleaned of the dust particles by depositing them on the wet-wall surface which flushes them out. Write: Patent Appl. 898 556/WG, U.S. Department of Agriculture, Research Agreements and Patent Management Branch, General Services Division, Federal Building, Agricultural Research Service, Hyattsville, Maryland 20782. Please send a copy of your initial correspondence to: Canadian Consulate, 3 Parkway Building, Suite 1310, Philadelphia, Pennsylvania 19102.

LICENSING OPPORTUNITIES FROM THE USSR

The following products and processes are offered for manufacture in Canada by Licensintorg, the Soviet state licensing organization. Address enquiries to: V/O LICENSINTORG, 31 Ul. Kahovka, 113461 Moscow, U.S.S.R. Please send a copy of your initial correspondence to: Commercial Division, Canadian Embassy, 23 Starokonyushenny Pereulok, Moscow, U.S.S.R.

Method for the Manufacture of Moulds to Cast Titanium and its Alloys

This is a method of casting shaped parts from titanium alloys using moulds prepared from powdered wastes of graphite costing one-fifth of artificial corundum. Since the mass of artificial corundum is 2.5 times as great as that of graphite, twice as many moulds can be prepared from an equal amount of graphite. After the casting has been knocked out of the mould, the remains of the mould can be crushed and recycled. The introduction of this method to existing foundries requires only simple equipment most of which is the usual type used in investment casting. A refractory slurry is prepared and applied to an investment pattern and dried. The resulting moulds make it possible to pour metal with a temperature of up to 2200°C at a rate of up to 1kg/s, strong enough to use in centrifugal casting so that shaped castings can be obtained with a wall thickness down to 1.2mm. The castings may also vary from 20g to 25kg in mass and up to 300x500x500mm in size. The dimensional accuracy of castings depends on their sizes and fixtures used. Castings have a clean bright surface free from burnt sand and a gasaturated layer. There is no need for etching, the surface layer can be machined without difficulty, thus lending itself to embossing for works of art, monuments, etc. In addition, the durability of cutting tools is increased two to four times.

Processing of Hydrogen Fluoride Gases

A process for the purification of gases which eliminates sludge dumping or effluent discharge and yields sodium fluoride for use in the production of aluminum, enamels, insecticides, fungicides, and in water fluoridation and wood preservatives. The purification technique involves the employment of standard absorbers, reactors, and settling tanks extensively used in chemical engineering. The gas purification is helped by a closed-loop system of recirculating the working solutions. To ensure protection of process equipment from corrosion, the pH of the working solution must be maintained close to 7. In the U.S.S.R., an industrial unit for the treatment of hydrogen fluoride gases at a rate of about 100,000 cu.m per hour has been operating since

LICENSES OFFERTES PAR L'URSS

Licensintorg, l'organisme d'État qui accorde des licences en Union soviétique, offre au Canada les droits de fabrication des produits et procédés suivants. Adresser toute demande de renseignements à: V/O LICENSINTORG, 31, rue Kakhovka, 113461 Moscou, URSS. Veuillez envoyer une copie de votre correspondance initiale à la Division commerciale, Ambassade du Canada, 23 Starokonyushenny Pereulok, Moscou, URSS.

Méthode de fabrication de moules pour le coulage du titane et de ses alliages

Il s'agit d'une méthode de coulage de pièces profilées à partir d'alliages de titane et à l'aide de moules préparés avec des résidus de graphite en poudre, coûtant cinq fois moins cher que le corindon artificiel. Comme la masse du corindon artificiel est 2,5 fois plus élevée que celle du graphite, on peut préparer deux fois plus de moules à partir d'une quantité équivalente de graphite. Une fois le coulage extirpé du moule, ce qui reste dans le moule peut être broyé et recyclé. L'introduction de cette méthode dans les fonderies ne nécessitera qu'un équipement simple, la plupart du temps du type couramment utilisé pour le coulage à la cire perdue. Un coulis réfractaire est préparé et appliqué dans le processus de coulage à la cire perdue et séchée. Les moules qui en résultent permettent de déverser du métal à une température pouvant atteindre 2200°C, au rythme de 1 kg/sec. Ces moules sont assez résistants pour que l'on puisse les utiliser dans le moulage par force centrifuge et obtenir des moules profilés dont la paroi peut être aussi mince que 1,2mm. Les moules peuvent varier entre 20 et 25 g (masse) et leur taille peut atteindre jusqu'à 300 x 500 x 500 mm. La précision dimensionnelle des moules dépend de leur taille et des récipients utilisés. Leur surface est unie et brillante, exempte de sable brûlé et de la couche saturée de gaz. Il n'est pas nécessaire de traiter le moulage à l'acide; la couche de surface peut être usinée sans difficulté, se prêtant aisément au bosselage pour la création artistique, la décoration de monuments, etc. De plus, la durabilité des outils de coupe s'en trouve accrue de deux à quatre fois.

Traitement des gaz de fluorure d'hydrogène

Il s'agit d'un procédé de purification des gaz, qui élimine les rejets de boue ou le déversement des effluents et libère du fluorure de sodium dans la production d'aluminium, de vernis, d'insecticides, de fongicides, ainsi que dans la fluoration de l'eau et la fabrication de préservatifs de bois. La technique de purification suppose l'emploi d'absorbants de type courant, de réacteurs et de bassins de colmatage, amplement utilisés dans le domaine du génie chimique. Un système en circuit fermé de remise en circulation des solutions actives contribue à la purification des gaz. Pour protéger l'équipement de traitement contre la corrosion, le niveau de pH de la solution active doit être maintenu aux environs de 7. En Union soviétique, une usine est en service depuis 1972 pour le traitement des gaz de fluorure d'hydrogène, à raison

1972 in conjunction with the manufacture of defluorinated phosphates, the recovery of sodium fluoride being about 50 kg per ton of rock phosphates.

Spherolite Adsorbents

Developed in the U.S.S.R., spherolites are used as an alternative to zeolites in desiccating gases and liquids and in removing detrimental impurities from various chemicals. Spherolites contain no binding agents which, essential in granular zeolites moulded from fine pulverized material, result in impairing the static absorbative capacity of the granules as well as affecting adversely their performance as molecular sieves and, in some instances, imparting to granules an unwanted catalytic activity. Spherolites are made, using conventional apparatus, from polychrystalline material (sodium silicate and sodium aluminate) by coagulating the starting material in the absence of mechanical granulators. This permits an output of as much as 3,000 tons of spherolites annually per production line. Various adsorbent types may be made by the incorporation of appropriate compounds. Spherolite granules are from 1.5 to 2 times as strong as zeolite granules. The maximum permissible height of the adsorbent bed is accordingly greater and the spherical granules provide for a smaller pressure drop compared to the pressure drop in the case of the usual rodlike granules of zeolite.

ADDRESS ENQUIRIES CONCERNING THE FOLLOWING CASE TO:

Canadian Patents and Development Limited
275 Slater Street
Ottawa, Canada
K1A 0R3

Fast Melting, Alloy Material, Bullets for Liquid Metal Baths

Case 6530

Designed for furnaces or ladles of molten metal, this unique bullet melts about twice as fast as present bullets. Melting occurs under the surface and minimizes loss of the alloying element to the slag or to atmosphere. It is most advantageous for ferrous melts.

de 100 000 mètres cubes à l'heure, de pair avec la production de phosphates défluorés, la récupération du fluorure de sodium étant d'environ 50 kg par tonne de phosphates de roche.

Adsorbants en sphérolite

Mises au point en URSS, les sphérolites peuvent se substituer aux zéolites dans la déshydratation des gaz et des liquides et dans l'enlèvement des impuretés nocives que renferment divers produits chimiques. Les sphérolites ne contiennent pas de liants qui, étant essentiels dans les zéolites granulées moulées à partir des matières réduites en poudre fine, nuisent à la capacité d'absorption statique des granules et gâtent leur rendement à titre de tamis moléculaires et, dans certains cas, communiquent aux granules une activité catalytique intertempore. Les sphérolites sont fabriquées avec un appareillage classique à partir des matières polycristallines (silicate de sodium et aluminat de sodium) en coagulant la matière d'amorçage sans granulateurs mécaniques. Ainsi, une chaîne de production peut livrer jusqu'à 3 000 tonnes de sphérolites par an. On peut réaliser divers types adsorbants en incorporant les composés appropriés. Les granules de sphérolite sont de 1,5 à 2 fois plus résistants que les granules de zéolite. En conséquence, la hauteur maximale permmissible du lit adsorbant augmente et les granules sphériques assurent une perte de pression inférieure à celle que manifestent les granules ordinaires de zéolite en forme de tiges.

PRIÈRE D'ADRESSER TOUTE DEMANDE DE RENSEIGNEMENTS AU SUJET DU CAS CI-APRÈS À LA:

Société canadienne des brevets et d'exploitation limitée
275, rue Slater
Ottawa, Canada
K1A 0R3

Balles d'alliage à fusion rapide pour bains de métal liquide

Cas 6530

Conçue pour les fourneaux ou poches de métal fondu, cette balle unique en son genre fond à peu près deux fois plus rapidement que les balles actuelles. La fusion se produit sous la surface et minimise ainsi la perte de l'élément d'addition dans l'atmosphère ou le laitier, ce qui est très avantageux pour les piquées de métaux ferreux.

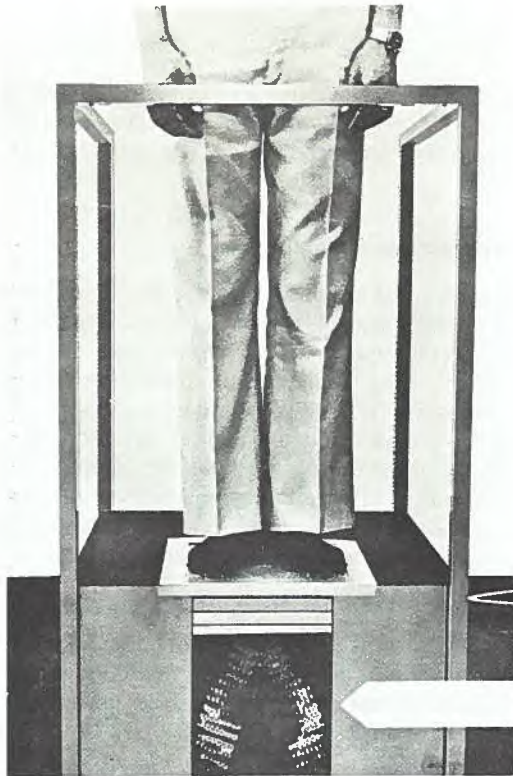

Orthopaedic Instrument
Appareil orthopédique

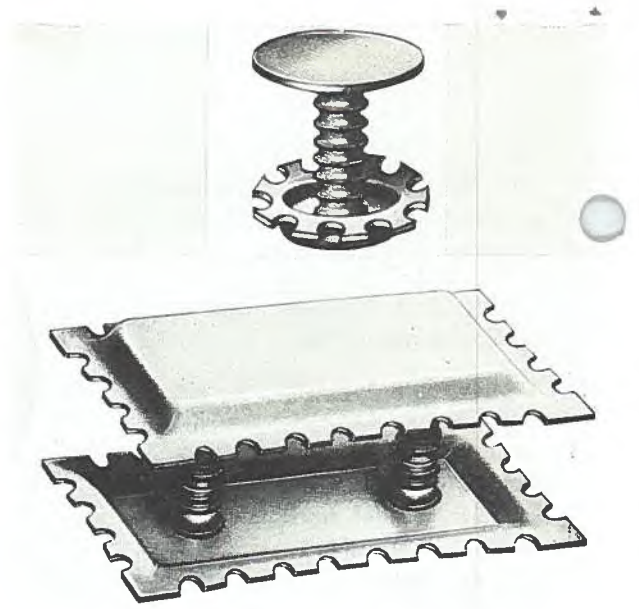

Chaplets
Supports de noyau



Centrifugal Casting Process for Large Pipes
Procédé de moulage centrifuge pour gros tuyaux



Knock-Down Furniture System