

new products bulletin

SCIENCE AND
TECHNOLOGY CANADA
LIBRARY
AUG 1 1996
BIBLIOTHÈQUE
INDUSTRIE, SCIENCE ET
COMMERCE

bulletin de produits nouveaux

This monthly bulletin is published to inform Canadian industry of licensing and joint venture opportunities that may be investigated for the purpose of forming manufacturing affiliations. The Department cannot assume any responsibility for claims made or for transactions which ensue from the publication of any items in this bulletin. If you are interested in any of the proposals you should contact the correspondent identified with the item and send a copy of your initial correspondence to the Canadian Government Trade Commissioner responsible for the area at the address indicated, in order that he can provide appropriate assistance or commercial information.

The Licensing Opportunities Section (34/3) of the BUSINESS CENTRE of the Department of Industry, Trade and Commerce, Ottawa, Ontario K1A 0H5 (Telephone: (613) 995-5771) should be advised of any agreements concluded as a result of this publicity.

Le présent bulletin, publié tous les mois, a pour objet d'informer l'industrie canadienne d'occasions de fabrication sous licence et d'entreprise en participation qu'il est possible d'étudier aux fins de constituer des affiliations manufacturières. Le Ministère ne peut assumer aucune responsabilité à l'égard des réclamations ou transactions découlant de la publication d'articles dans le présent bulletin. Si l'une ou l'autre des propositions vous intéresse, auriez-vous l'obligance de communiquer avec le correspondant et transmettre copie de votre premier échange de correspondance au délégué commercial du Gouvernement du Canada qui s'occupe de la région en cause, à l'adresse indiquée, afin qu'il puisse vous fournir l'aide ou les renseignements commerciaux pertinents.

Prière d'informer la Section des possibilités de licences (34/3), du CENTRE DES ENTREPRISES, ministère de l'Industrie et du Commerce, Ottawa (Ontario) K1A 0H5 (Téléphone: (613) 995-5771), de toute entente intervenue à la suite de la présente publicité.

DECEMBER 1979

BULLETIN 287

DÉCEMBRE 1979

Computer Design of Thin Film Filter Systems I/287

Optical thin film filter systems can be automatically designed by this program. Write: Case 3772, Canadian Patents and Development Limited, 275 Slater Street, Ottawa, Canada K1A 0R3 and send a copy of your initial correspondence to: Licensing Opportunities Section (34/3), Business Centre, Department of Industry, Trade and Commerce, Ottawa, Canada K1A 0H5.

Diver's Hand Held Sonar/287

A portable sonar which enables a diver to detect and often identify objects in low visibility conditions. A two foot diameter sphere can be detected at a range of about 250 metres and the nature of the target determined from the audio signature of the echo. Write: Case 6520, Canadian Patents and Development Limited, 275 Slater Street, Ottawa, Canada K1A 0R3 and send a copy of your initial correspondence to: Licensing Opportunities Section (34/3), Business Centre, Department of Industry, Trade and Commerce, Ottawa, Canada K1A 0H5.

Latent Fingerprint/Detection Process/287

This chloride-sensitive, non-aqueous fingerprinting process is particularly suitable for use with substrates which are susceptible to damage by aqueous systems such as inks, dyes and/or cellulosic materials. Write: Case 6577, Canadian Patents and Development Limited, 275 Slater Street, Ottawa, Canada K1A 0R3 and send a copy of your initial correspondence to: Licensing Opportunities Section (34/3), Business Centre, Department of Industry, Trade and Commerce, Ottawa, Canada K1A 0H5.

Conception informatisée des systèmes de filtres à pellicule mince I/287

Ce programme peut concevoir automatiquement les systèmes de filtres optiques à pellicule mince. Écrire: Cas 3772, Société canadienne des brevets et d'exploitation limitée, 275, rue Slater, Ottawa (Canada) K1A 0R3 et faire parvenir une copie de votre correspondance initiale à la: Section des possibilités de licences (34/3), Centre des entreprises, Ministère de l'Industrie et du Commerce, Ottawa (Canada) K1A 0H5.

Sonar à main pour plongeur/287

Sonar portatif qui permet à un plongeur de dépister et souvent d'identifier des objets lorsque la visibilité est faible. Il peut découvrir une sphère d'un diamètre de deux pieds à quelque 250 mètres et préciser la nature de la cible d'après le signal audio de l'écho. Écrire: Cas 6520, Société canadienne des brevets et d'exploitation limitée, 275, rue Slater, Ottawa (Canada) K1A 0R3 et faire parvenir une copie de votre correspondance initiale à la: Section des possibilités de licences (34/3), Centre des entreprises, Ministère de l'Industrie et du Commerce, Ottawa (Canada) K1A 0H5.

Procédé de détection des empreintes digitales latentes/287

Ce procédé non aqueux chloruro-sensible de détection d'empreintes digitales est tout indiqué pour les substrats susceptibles aux dégâts des systèmes aqueux: encres, teintures et (ou) matières cellulosiques. Écrire: Cas 6577, Société canadienne des brevets et d'exploitation limitée, 275, rue Slater, Ottawa (Canada) K1A 0R3 et faire parvenir une copie de votre correspondance initiale à la: Section des possibilités de licences (34/3), Centre des entreprises, Ministère de l'Industrie et du Commerce, Ottawa (Canada) K1A 0H5.



Government
of Canada

Gouvernement
du Canada

Industry, Trade
and Commerce

Industrie
et Commerce



Gouvernement
du Canada

Government
of Canada

Industrie
et Commerce

Industry, Trade
and Commerce

Quadrupole Mass Spectrometer/287

This quadrupole mass spectrometer operates with only an RF voltage and therefore does not require the usual complex precision circuitry for control of the RF/DC ratio. The geometrical tolerances of the rods are less critical and the instrument will operate efficiently at high masses. Write: Case 6641, Canadian Patents and Development Limited, 275 Slater Street, Ottawa, Canada K1A 0R3 and send a copy of your initial correspondence to: Licensing Opportunities Section (34/3), Business Centre, Department of Industry, Trade and Commerce, Ottawa, Canada K1A 0H5.

Multi-Filar Moving Coil Loudspeaker/287

An efficient multi-filar moving coil loudspeaker which is substantially resistive in the audio range and which was developed specifically for the telephone conferencing system of Case 7026. Write: Case 6872, Canadian Patents and Development Limited, 275 Slater Street, Ottawa, Canada K1A 0R3 and send a copy of your initial correspondence to: Licensing Opportunities Section (34/3), Business Centre, Department of Industry, Trade and Commerce, Ottawa, Canada K1A 0H5.

Power Inverter/287

A light, efficient and portable power inverter that will provide a 110V, 60Hz supply from a 24V D.C. source. (No patent coverage – all enquiries will be referred to the source laboratory.) Write: Case 6895, Canadian Patents and Development Limited, 275 Slater Street, Ottawa, Canada K1A 0R3 and send a copy of your initial correspondence to: Licensing Opportunities Section (34/3), Business Centre, Department of Industry, Trade and Commerce, Ottawa, Canada K1A 0H5.

Animal Trap/287

An animal trap designed to kill rapidly and humanely. Write: Case 6932, Canadian Patents and Development Limited, 275 Slater Street, Ottawa, Canada K1A 0R3 and send a copy of your initial correspondence to: Licensing Opportunities Section (34/3), Business Centre, Department of Industry, Trade and Commerce, Ottawa, Canada K1A 0H5.

Broadband Shaped Beam Antenna/287

This small, streamlined broadband antenna provides a uniform hemispheric response which is largely independent of the size of the ground plane. It was specially designed for the reception of satellite signals by moving vehicles. Write: Case 6943, Canadian Patents and Development Limited, 275 Slater Street, Ottawa, Canada K1A 0R3 and send a

Spectromètre de masse quadripolaire/287

Ce spectromètre de masse quadripolaire fonctionne avec tension RF seulement et se passe donc des circuits de précision complexes ordinairement requis pour contrôler le rapport RF/CC. Les tolérances géométriques des tiges sont moins critiques et l'instrument est efficace avec des masses élevées. Écrire: Cas 6641, Société canadienne des brevets et d'exploitation limitée, 275, rue Slater, Ottawa (Canada) K1A 0R3 et faire parvenir une copie de votre correspondance initiale à la: Section des possibilités de licences (34/3), Centre des entreprises, Ministère de l'Industrie et du Commerce, Ottawa (Canada) K1A 0H5.

Haut-parleur dynamique multifilaire/287

Ce haut-parleur dynamique multifilaire est efficace et assez résistif dans la gamme des audiofréquences; il a été mis au point à l'intention spéciale du réseau de conférence téléphonique décrit dans le cas 7026. Écrire: Cas 6872, Société canadienne des brevets et d'exploitation limitée, 275, rue Slater, Ottawa (Canada) K1A 0R3 et faire parvenir une copie de votre correspondance initiale à la: Section des possibilités de licences (34/3), Centre des entreprises, Ministère de l'Industrie et du Commerce, Ottawa (Canada) K1A 0H5.

Invertisseur de puissance/287

Invertisseur de puissance léger, efficace et portable qui établit une source de courant 110 V. 60 Hz à partir de 24 V en courant continu. (Aucun brevet – toutes les demandes de renseignements seront transmises au laboratoire d'origine.) Écrire: Cas 6895, Société canadienne des brevets et d'exploitation limitée, 275, rue Slater, Ottawa (Canada) K1A 0R3 et faire parvenir une copie de votre correspondance initiale à la: Section des possibilités de licences (34/3), Centre des entreprises, Ministère de l'Industrie et du Commerce, Ottawa (Canada) K1A 0H5.

Piège pour animaux/287

Piège conçu en vue de tuer rapidement et sans cruauté. Écrire: Cas 6932, Société canadienne des brevets et d'exploitation limitée, 275, rue Slater, Ottawa (Canada) K1A 0R3 et faire parvenir une copie de votre correspondance initiale à la: Section des possibilités de licences (34/3), Centre des entreprises, Ministère de l'Industrie et du Commerce, Ottawa (Canada) K1A 0H5.

Antenne à bande large à faisceau profilé/287

Cette petite antenne à bande large aux lignes élancées établit une réponse hémisphérique uniforme assez indépendante des dimensions du plan de terre. Elle a été conçue tout spécialement pour la réception des signaux des satellites à bord des véhicules en mouvement. Écrire: Cas 6943, Société canadienne des brevets et d'exploitation limitée, 275, rue Slater, Ottawa (Canada) K1A 0R3 et faire

copy of your initial correspondence to: Licensing Opportunities Section (34/3), Business Centre, Department of Industry, Trade and Commerce, Ottawa, Canada K1A 0H5.

Loudspeaker for Telephone Systems/287

This loudspeaker is specifically designed for telephone conferencing and it functions as both loudspeaker and microphone. When in operation, the receive and transmit modes are not acoustically isolated from one another, i.e., no voice switching is necessary to eliminate the possibility of sing-around paths. Also, the possibility of lock-out is eliminated. Write: Case 7026, Canadian Patents and Development Limited, 275 Slater Street, Ottawa, Canada K1A 0R3 and send a copy of your initial correspondence to: Licensing Opportunities Section (34/3), Business Centre, Department of Industry, Trade and Commerce, Ottawa, Canada K1A 0H5.

Computer/Design of Thin Film Filter Systems II/287

Optical thin film filter systems can be automatically designed by this program which is based on the use of Fourier transforms. Write: Case 7053, Canadian Patents and Development Limited, 275 Slater Street, Ottawa, Canada K1A 0R3 and send a copy of your initial correspondence to: Licensing Opportunities Section (34/3), Business Centre, Department of Industry, Trade and Commerce, Ottawa, Canada K1A 0H5.

Solar Energy Systems/287

American licensing agent for U.S. firm seeks a Canadian company to manufacture and market "SUNPUMP" solar energy systems under license in Canada. Export rights are negotiable once production has been established. The firm will assist the company in setting up manufacturing facilities and provide full technical and managerial support in establishing manufacturing and sales operations for the solar collector and related products. The "SUNPUMP" systems use the latent heat of vaporization of water (phase change energy) as the energy transport medium. This method requires no electrical pumping. In addition, the device provides a variable flow, constant temperature output, thus eliminating electrically powered energy pumping which exhibit constant flow, variable temperature outputs. Other advantages include: temperature range for air conditioning, industrial process heat, water and forced air space heating, domestic water and swimming pool heating; patented application of heat pipe technology to solar energy systems; high system efficiency; concentrating collector for higher temperatures; no tracking devices or seasonal adjustments; constant high temperature output into storage 100°C (212°F); no auxiliary power required: no pumps, fans, blowers, controllers,

parvenir une copie de votre correspondance initiale à la: Section des possibilités de licences (34/3), Centre des entreprises, Ministère de l'Industrie et du Commerce, Ottawa (Canada) K1A 0H5.

Haut-parleur pour réseaux téléphoniques/287

Ce haut-parleur est conçu tout spécialement pour les conférences téléphoniques; il sert à la fois de haut-parleur et de microphone. Lorsqu'il est en service, les modes réception et transmission ne sont pas isolés l'un de l'autre, c'est-à-dire qu'aucune commutation phonique n'est requise pour supprimer les éventuels parcours d'écho. En outre, la possibilité de verrouillage est supprimée. Écrire: Cas 7026, Société canadienne des brevets et d'exploitation limitée, 275, rue Slater, Ottawa (Canada) K1A 0R3 et faire parvenir une copie de votre correspondance initiale à la: Section des possibilités de licences (34/3), Centre des entreprises, Ministère de l'Industrie et du Commerce, Ottawa (Canada) K1A 0H5.

Conception informatisée des systèmes de filtres à pellicule mince II/287

Ce programme peut concevoir automatiquement des systèmes de filtres optiques à pellicule mince; il est fondé sur l'emploi des transformations de Fourier. Écrire: Cas 7053, Société canadienne des brevets et d'exploitation limitée, 275, rue Slater, Ottawa (Canada) K1A 0R3 et faire parvenir une copie de votre correspondance initiale à la: Section des possibilités de licences (34/3), Centre des entreprises, Ministère de l'Industrie et du Commerce, Ottawa (Canada) K1A 0H5.

Systèmes d'énergie solaire/287

Un agent d'octroi de licences américain d'une firme des É.-U. offre à une compagnie canadienne les droits de fabrication et de commercialisation au Canada, sous licence, de systèmes d'énergie solaire "SUNPUMP". Les droits d'exportation seront négociables lorsque la production aura commencé. La firme aidera la compagnie à monter les installations de fabrication et lui fournira toute l'aide technique et administrative nécessaire à la fabrication et à la vente de collecteurs solaires et produits connexes. Les systèmes "SUNPUMP" utilisent la chaleur latente de la vaporisation de l'eau (énergie de déphasage) comme moyen de transport énergétique. Cette méthode n'exige pas le pompage électrique. De plus, le système fournit un débit à température continue et à régime variable, ce qui élimine le pompage à l'aide d'énergie électrique qui donne un débit à température variable et à régime continu. Les autres avantages: l'échelle de température pour la climatisation; la chaleur pour les procédés industriels, l'eau et les radiateurs à air pulsé; le chauffage de l'eau ménagère et des piscines; l'application brevetée de la technologie des tuyaux de chauffage aux systèmes d'énergie solaire; un système très efficace; un collecteur de concentration pour les températures plus élevées; aucun système de réglage et pas d'ajustements saisonniers; stockage continu de forte chaleur, soit 100°C

logic circuits; simple, small size piping for easy installation and insulating; no toxic or combustible fluids; no damage from freezing or stagnation temperatures; large energy capacity to volume ratio for effective energy transport and exchange; combination heat exchanger/storage tank; many storage/heat exchange options; self-adjusting storage response times; immediate availability of solar energy: no reheating of storage mass; retrofit without reconstruction; collector mounting flexibility. See illustration. Write: Mr. David Lass, PVL International Inc., Licensing Agent for Entropy Limited, 25 Winter Street, Nahant, Massachusetts 01908 and send a copy of your initial correspondence to: Canadian Consulate General, 500 Boylston Street, Boston, Massachusetts 02116.

Electronic Industrial Switches/287

German manufacturer of products currently being sold to firms manufacturing machines having control panels; firms producing control panels for machinery manufacturers; and firms producing their own control panels, e.g., steel, automotive, chemical, etc., seeks a joint venture partner in Canada having electrotechnical capabilities to sell and eventually manufacture the firm's products in Canada and the United States. The products include items for control panels of various types; e.g., electronic time relays for control programs for mixing plants, proportioning plants, electric irons, textile furnishing installations, galvanizing process and other specialty checking and control systems as well as electronic relays, punched tape readers, program control, electronic magnetic controls, etc. Possible partners could be manufacturers of light barriers, magnets, control cables, cable clamps, cable eyes or those having the capability to manufacture such products. The German firm's products are now in commercial production in most European and Scandinavian countries. Write: Mr. Herbert Scharpenack, Scharco-Electronik, Scharpenack GmbH & Co. KG, Königsbergerstr. 5 - 17, 5600 Wuppertal 2, Germany and send a copy of your initial correspondence to: Canadian Consulate General, Immermannstrasse 3, 4 Duesseldorf, West Germany.

Yarn, Fabric, Knitted Goods and Methods of Production/287

Czechoslovakian Foreign Trade Corporation on behalf of the Czechoslovakian Knitting Research Institute, offers manufacturing rights to a Canadian company along with

(212°F); élimination de puissance auxiliaire, notamment de pompes, ventilateurs, souffleurs, contrôleurs et circuits logiques; tuyautage simple et de petite dimension qui simplifie l'installation et l'isolation; aucun fluide toxique ou combustible; aucun dommage causé par la congélation ou des températures inertes; un important rapport capacité-volume d'énergie qui rend le transport et l'échange d'énergie efficaces; réservoir de stockage et échangeur de chaleur combinés; multiples options stockage/échange de chaleur; temps de réaction du stockage à réglage automatique; disponibilité immédiate de l'énergie solaire; pas de réchauffage de la masse de stockage; modifications apportées à l'équipement sans besoin de reconstruction; flexibilité d'assemblage du collecteur. Voir l'illustration. Écrire à: M. David Lass, PVL International Inc., Agent d'octroi de licences pour Entropy Limited, 25 Winter Street, Nahant, Massachusetts 01908 et adresser une copie de votre correspondance initiale au: Consulat général du Canada, 500 Boylston Street, Boston, Massachusetts 02116.

Commutateurs industriels électroniques/287

Un fabricant allemand de produits vendus actuellement à des entreprises qui fabriquent des machines munies de tableaux de commande, à des entreprises qui produisent des tableaux de commande destinés à des fabricants de machines, et à des entreprises qui fabriquent leurs propres tableaux de commande (par ex., industries de l'acier, de l'automobile, des produits chimiques, etc.) cherche un associé canadien pour mettre sur pied une coentreprise qui possédera les compétences électrotechniques qui lui permettront de vendre et, peut-être de fabriquer les produits que cette entreprise vend au Canada et aux États-Unis. Ces produits comprennent les éléments de divers genres de tableaux de commande; par exemple, des relais électroniques temporisés utilisés dans le cadre de programmes de contrôle des usines de malaxage et de dosage, des fers électriques, des installations de fabrication de meubles recouverts de textile, aux fins de galvanisation et pour d'autres systèmes spéciaux de vérification et de contrôle, ainsi que des relais électroniques, des têtes de lecture de bandes perforées, des commandes de programmes, des commandes magnétiques électroniques, etc. Les associés éventuels pourraient être des fabricants de barrages photo-électriques, d'aimants, de câbles de commande, d'attaches de câbles, de cosses ou ceux qui sont capables de fabriquer ces produits. L'entreprise allemande en est actuellement à l'étape de la production commerciale dans la plupart des pays européens et scandinaves. Écrire à: M. Herbert Scharpenack, Scharco-Electronik, Scharpenack GmbH & Co., Königsbergerstr. 5 - 17, 5600 Wuppertal 2, Allemagne et envoyer une copie de votre correspondance initiale au: Consulat général du Canada, Immermannstrasse 3, 4 Düsseldorf, Allemagne de l'Ouest.

Articles en filé, tissu et tricot et méthodes de production/287

Une société tchécoslovaque de commerce étranger offre, au nom de l'institut tchécoslovaque de recherches textiles, les droits de fabrication des produits suivants à une société

marketing rights for North and Latin America for:

HYBRIFIL — A hybrid textured high-bulk yarn and method of producing same. Based on shrinkage rates of different materials during production, individual filaments in the yarn provide specific yarn geometry of excellent quality. The fine yarns, from 70 to 400 dtex, are used in light knitted outerwear. Air jet texturing machine equipped with heat shrinkage device and re-winding machine are necessary.

PLASTITEX — A non-woven patterned stitched-knitted fabric used in upholstery and furnishing materials, produced by joining basic elastomeric foam layer by needling with a fibrous web, subsequent processing on non-woven upholstery fabric factory equipment or on the stitch-knitting machine **ARACHNE**. This machine's operation provides simultaneous reinforcing and patterning and final finishing according to end use.

POLARA — A non-woven patterned stitch-knitted loop fabric and method of processing same consisting essentially of two systems of warp-threads which can be lapped so that loops of same or different heights are formed. Suitable for upholstery, draperies, and in heavier weights, for floor coverings with possibility of 3D shaping using non-woven factory equipment or the **ARACHNE** machine.

ESTEROLITE — A non-woven insulating floor covering. The fabric has at least one basic insulating layer of inorganic material, specifically glass fibres. After prior reinforcing by needling, bonding, etc., the layer is processed on non-woven carpet production equipment or the **ARACHNE** machine and then coated on at least one side (face) with flame resistant plastic or rubber layer and provided with convenient surface finish.

DUONIT — Knitted slacks and method of producing same. This moulded garment production utilizes thermoplastic properties of synthetic fibres. The production of slacks consists of manufacturing two seamless tubular trouser legs from yarns comprising a substantial part of thermoplastic fibres which are then heat-set and sewn together in a single seam at the crotch section, followed by final make up. The Knitting Research Institute will supply complete technological know-how including production line schemes with information for these processes concerning effective capacity, material consumption, number of operators, etc. Also specialists can visit the licensor's factory to initiate production and to supply technical aid. To investigate licensing rights to each process write: Mr. Jan Volny, Section 26, Polytechna, Panska 6, P.O. Box 834, 112 45 Praha 1, Czechoslovakia and send a copy of your initial correspondence to: Commercial Division, Canadian Embassy, Mickiewiczova 6, 125 33 Prague 6, Czechoslovakia.

Rotary Clothes Hoist/Umbrella/Tent/287

Australian company offers to a Canadian manufacturer the North American, South American and Middle East manu-

canadienne, ainsi que les droits de commercialisation pour l'Amérique du nord et l'Amérique latine.

HYBRIFIL — Il s'agit d'un filé hybride texturé à volume élevé et de sa méthode de production. A partir des taux de retrait au cours de la production des différents matériaux, chaque filament du filé offre une géométrie spécifique du fil d'excellente qualité. Les filés fins, de 70 à 400 dtex, peuvent servir pour des survêtements tricotés légers. Il faut un appareil à texturation par jet d'air muni d'un dispositif de retrait par la chaleur et d'un rebobineur.

PLASTITEX — Il s'agit d'un tissu à mailles tricotées et à dessin non tissé pouvant servir à l'ameublement. Il se fabrique en joignant par aiguilletage une base de mousse d'élastomères et un voile fibreux, matériau qui sera ensuite traité par de l'équipement pour fabriquer du tissu d'ameublement non tissé ou la machine **ARACHNE** pour mailles tricotées. Cette machine permet simultanément de renforcer, dessiner et donner sa texture au tissu selon sa destination.

POLARA — Il s'agit d'un tricot bouclette dessiné à mailles tricotées non tissées et la méthode de traitement consiste essentiellement en deux réseaux de fils de chaîne qui peuvent être rabattus de façon à obtenir des bouclettes de la hauteur désirée, qui peut ne pas être uniforme. Ce tissu peut servir pour l'ameublement et les tentures et, lorsqu'il est plus épais, pour des moquettes, avec la possibilité de faire des dessins tridimensionnels avec de l'équipement pour tissus non tissés ou la machine **ARACHNE**.

ESTEROLITE — Il s'agit d'une moquette isolante non tissée. Le tissu a au moins une couche de base isolante inorganique, plus précisément des fibres de verre. Après un premier renforcement par liage, aiguilletage, etc., cette couche est traitée sur de l'équipement de production de tapis non tissés ou la machine **ARACHNE** et enduit ensuite sur au moins une face d'une couche de plastique ou de caoutchouc ignifuge, pour ensuite recevoir le fini approprié.

DUONIT — Pantalons d'intérieur tricotés et leur méthode de production. Cette méthode de production des vêtements par moulage exploite les propriétés thermoplastiques des fibres synthétiques. Pour les pantalons, on fabrique deux jambes tubulaires sans coutures, à partir de filés comprenant une bonne proportion de fibres thermoplastiques, qui sont alors fixées par la chaleur pour ensuite être jointes à l'entre-jambes par une couture unique, étape suivie de la confection finale.

L'institut fournira toutes les compétences techniques, y compris des plans de chaîne de production avec des données sur la capacité réelle, la consommation de matériel, le nombre d'employés, etc. touchant ces procédés. De plus, des spécialistes peuvent visiter l'usine du détenteur de la licence pour apporter une aide technique et aider à la production initiale. Pour plus de renseignements sur l'un de ces procédés, écrire à: M. Jan Volny, Section 26, Polytechna, Panska 6, Casier postal 834, 112 45 Praha 1, Tchécoslovaquie, et veuillez transmettre une copie de votre correspondance initiale à la Division commerciale de l'ambassade du Canada, Mickiewiczova 6, 125 33 Prague 6, Tchécoslovaquie.

Séchoir à linge rotatif/parapluie/tente/287

Une société australienne offre à un fabricant canadien les droits de fabrication et de commercialisation en Amérique

facturing and marketing rights for its patented rotary clothes hoist which may also be converted into a sun umbrella or tent. The hoist is collapsible or foldable, made of lightweight aluminum with poly-cotton covering. The complete tent structure weighs 12 kilograms. The apparatus can be erected easily by one person in approximately four minutes, fits into the trunk of a small car, can serve as an ideal emergency shelter or as a covered/uncovered clothes dryer so that some clothes-drying will take place, or dry clothes remain so, during rainfall. See illustrations. Write: Aussie Campa Champ Pty. Ltd., P.O. Box 1461, Canberra City, 2601 Australia and send a copy of your initial correspondence to: Canadian Consulate General, A.M.P. Centre, 8th Floor, 50 Bridge Street, Sydney, N.S.W. 2000, Australia.

Carrying Handle/287

Canadian company offers domestic manufacturing and worldwide marketing rights to its "Cariband" plastic carrying device for cans, bottles, etc. The device is internationally patented and trademarked. Automatically applied by a "Caribander" machine available from the licensor, the device circles all types of containers; metal, composite, fibre and plastic as well as intravenous bottles and is provided with a carrying means. Its advantages are said to be: savings of up to 50% compared to metal bail bands; cannot be pulled off once applied; meets environmental disposal requirements; is chemically inert; easily colour-coated for identification; no sharp edges; does not damage the containers and eliminates corrosion and label application problems. See illustrations. Write: Caristrap Corporation, 1760 Fortin Blvd, Chomedey, Laval, Quebec, H7S 1N8 and send a copy of your initial correspondence to: The Licensing Opportunities Section (34/3), Business Centre, Department of Industry, Trade and Commerce, Ottawa, Ontario, K1A 0H5.

Grade Checker/287

American company offers a Canadian manufacturer having contacts in the construction industry the licensing rights to manufacture, distribute and export a new product for use independently by non-skilled workers to verify the accuracy of earth-work grading, surfacing and proper drainage levels. This unique grade-checking tool has a patent pending in the U.S. It is designed for construction field personnel, including engineers, technicians, inspectors, earth work foremen and grade checkers. It is a vertically disposed telescopic rod having three scales. A line reel connects the top end of a reciprocating rod in which is placed a bull's eye level. A line level is included for certain grade checking requirements. All parts are replaceable. The device can be used to replace grade stakes without requiring a survey team; to replace hand-held string-line, lock levels and other jerry-rigged devices, as well as eliminating the requirement of at least one helper on grade checking teams. See illustration. Write: Mr. Alden L. Coke, President, Design and

du Nord, en Amérique du Sud et au Moyen-Orient, de son séchoir à linge rotatif qui peut également se transformer en parasol ou en tente. L'appareil en aluminium léger recouvert de toile est démontable ou pliable. La structure entière de la tente pèse 12 kilogrammes. Une personne seule peut monter l'appareil en quatre minutes environ et il se range dans le coffre d'une petite voiture. En cas de pluie, il peut même servir d'abri d'urgence ou de séchoir à linge couvert ou non couvert pour le séchage des vêtements ou la protection des vêtements secs. Voir les illustrations. Écrire à: Aussie Campa Champ Pty. Ltd., P.O. Box 1461, Canberra City, 2601 Australie et adresser une copie de votre correspondance initiale au: Consulat général du Canada, A.M.P. Centre, 8th Floor, 50 Bridge Street, Sydney, N.S.W. 2000, Australie.

Poignée pour récipients/287

Une société canadienne offre les droits de fabrication au Canada et de commercialisation à l'échelle mondiale de son dispositif "Cariband" qui sert de poignée à des boîtes de fer blanc, des bouteilles, etc. Ce dispositif jouit d'un brevet et d'une marque de fabrique internationaux. Automatiquement appliqué par une machine "Caribander" fournie par l'octroyeur de licence, le dispositif encercle tous genres de contenants, qu'il soient en métal, mixtes, en fibre ou en plastique, y compris les bouteilles intraveineuses, et peut servir de poignée. Il coûte jusqu'à 50% moins cher que les bandes de métal; ne peut être arraché une fois appliqué; satisfait aux exigences en matière d'environnement; est chimiquement inerte; s'enrobe facilement de couleur pour identification; n'a pas de saillies pointues; n'endommage pas les contenants et élimine la corrosion et les problèmes d'application des étiquettes. Voir les illustrations. Écrire à: Caristrap Corporation, 1760, boul. Fortin, Chomedey, Laval (Québec) H7S 1N8 et envoyer une copie de votre correspondance initiale à: La Section des possibilités de licences (34/3), Centre des entreprises, Ministère de l'Industrie et du Commerce, Ottawa (Ontario) K1A 0H5.

Outil de vérification du nivellement/287

Une société américaine offre à un fabricant canadien qui possède des contacts dans l'industrie de la construction les droits de licence pour la fabrication, la distribution et l'exportation d'un nouveau produit qui servira à des ouvriers non qualifiés pour vérifier la précision des niveaux de terrassement, de revêtement et d'égouttement. Cet outil unique fait l'objet d'une demande de brevet aux États-Unis. Il est utilisé par les employés du secteur de la construction, y compris les ingénieurs, les techniciens, les inspecteurs, les préposés au terrassement et à la vérification du nivellement. Il s'agit d'une tige télescopique verticale munie de 3 galons. Un dévidoir est rattaché à la partie supérieure d'une tige à mouvement alternatif qui renferme un niveau à bulle sphérique. Un niveau linéaire permet d'effectuer certaines tâches de vérification du nivellement. Toutes les pièces peuvent être remplacées. Cet outil peut servir à remplacer des piquets de nivellement sans l'aide d'une équipe de spécialistes, à remplacer un fil tenu manuellement, un niveau verrouillé et

Funding Inc., 8767 Satyr Hill Road, Baltimore, Maryland 21234 and send a copy of your initial correspondence to: Canadian Consulate, 3 Parkway Building, Suite 1310, Philadelphia, Pennsylvania 19102.

Modular Kitchens/287

New Zealand company offers a Canadian manufacturer the licensing rights to produce for the North American market its patented modular kitchen cabinet technique which facilitates the shipment of knocked-down cabinets to the consumer. The system takes particular advantage of special cabinet connecting screws, concealed hinges and camlock fittings. With simple tools, cabinets can easily be assembled by the builder or homeowner. Special plant equipment is apparently not required if a licensee is an established millworker or furniture manufacturer. The quality and workmanship is claimed to be superior to other systems and to incorporate a much quicker assembly method. Write: Mr. W.M.J. Panettieri, Contessa Manufacturing Limited, P.O. Box 37,165, Stokes Valley, New Zealand and send a copy of your initial correspondence to: Commercial Division, Canadian High Commission, P.O. Box 12-049 Wellington North, ICI Building, 3rd Floor, Molesworth Street, Wellington, New Zealand.

Loose-leaf Binders/287

Swedish firm seeks a licensee in Canada to manufacture "Isbergs" patented binders for the North American market. These ring binders have backs of moulded color coded polypropene making possible the creation of more sophisticated shapes and functions. The covers can be made of grey strong artificial leather cardboard, bound, welded or hard plastic. Raised headbands make the binder rest on four points only when lying on its back. A label pocket of soft plastic makes it easy to change the label. An indented finger grip facilitates handling and saves space vertically and the concave base gives good balance and a smaller area of wear. Rings and locking devices are of metal in two positions with the following centimeter hole distance: 20-80-20, 80-80-80, 21-70-21, 70-70-70. See illustrations. Write: Mr. Frank Brkic, Mosaic Enterprises Inc., P.O. Box 3786, Washington, D.C. 20007 and send a copy of your initial correspondence to: Canadian Consulate, 3 Parkway Building, Suite 1310, Philadelphia, Pennsylvania 19102.

Plasma Arc Cutting/287

East German manufacturer offers licensing rights in Canada for its technology for the plasma arc cutting of feeders, gatings and runners of carbon cast steel, low alloy cast steel as

d'autres appareils dont les matériaux de fabrication sont de faible qualité. Cet outil élimine également la nécessité d'avoir au moins un aide dans chaque équipe de vérification du nivellement. Voir l'illustration. Écrire à: M. Alden L. Coke, président de Design and Funding Inc., 8767 Satyr Hill Road, Baltimore, Maryland 21234 et envoyer une copie de votre correspondance initiale au: Consulat du Canada, 3 Parkway Building, Suite 1310, Philadelphia, Pennsylvania 19102.

Cuisines modulaires/287

Une société de la Nouvelle-Zélande offre à un fabricant canadien les droits de fabriquer sous licence, pour le marché nord-américain, ses armoires de cuisines modulaires brevetées. Grâce à cette technique, les armoires démontées peuvent être expédiées facilement au consommateur. Les vis d'assemblage, les charnières invisibles et les raccords Camlock apportent un avantage particulier au système. L'entrepreneur ou le propriétaire peut assembler facilement les armoires à l'aide d'outils simples. Apparemment, si le titulaire d'une licence possède un atelier reconnu ou est un fabricant de meubles, il n'a pas besoin d'outillage spécial. La qualité du produit fini est, semble-t-il, supérieure aux autres systèmes et la méthode d'assemblage est beaucoup plus rapide. Écrire à: M. W.M.J. Panettieri, Contessa Manufacturing Limited, P.O. Box 37, 165, Stokes Valley, Nouvelle-Zélande et adresser une copie de votre correspondance initiale à la: Division commerciale, Haut-Commissariat du Canada, P.O. Box 12-049 Wellington North, ICI Building, 3^e étage, Molesworth Street, Wellington, Nouvelle-Zélande.

Reliures à feuilles mobiles/287

Une firme suédoise recherche une société au Canada désireuse de fabriquer des reliures brevetées "Isbergs" pour le marché nord-américain. Le dos de ces reliures à anneaux est fait de polypropène moulé en couleurs déterminées selon des codes, ce qui rend possible la création de formes et de fonctions plus perfectionnées. Leur couverture est en solide carton gris, en similicuir ou en plastique lié, soudé ou tout en plastique. Les tranchefiles en relief permettent à la reliure de reposer sur quatre points seulement de son dos. Grâce à une pochette en plastique souple, il est facile de changer l'étiquette. Le bas du dos a une forme dentelée; ainsi on peut mieux prendre la reliure avec la main et économiser l'espace vertical. La base concave du dos favorise l'équilibre et réduit la surface d'usure. Les anneaux et dispositifs de blocage sont en métal et disposés de deux façons. Les distances des trous en centimètres: 20-80-20, 80-80-80, 21-70-21, 70-70-70. Voir les illustrations. Écrire à: M. Frank Brkic, Mosaic Enterprises Inc., P.O. Box 3736, Washington, D.C. 20007 et envoyer une copie de votre correspondance initiale au: Consulat du Canada, 3 Parkway Building, Suite 1310, Philadelphie, Pennsylvania 19102.

Découpage à l'arc au plasma/287

Un fabricant de l'Allemagne de l'Est offre à une société canadienne, sous licence, sa technologie du découpage à

well as alloy cast steel. The finishing of medium and large castings by means of plasma arcs is accomplished by separating cross sections, sprues and feed points. This electronically controlled mechanism offers tremendous advantages in comparison with conventional systems of manual cutting processes, such as flame cutting, powder flame cutting and gouging: e.g., lower production costs; higher efficiency; up to 90% reduction in grinding effort at the joints; better working conditions; removal of losses of various materials in one process on the basis of a particular moulding practice; several castings are processed at the same time – different ranges of castings are separated from the losses by a uniform centering and cutting procedure; quality of cuts meets the foundry quality standard requirements. Carbon cast steel up to as high alloy cast steel, cast iron, (GGG, GGV), G-A1 (cast aluminum)_{aa}G-Ms (brass castings) runners, parting gates, etc., up to 125 mm (5") can be economically cut from the casting by application of one uniform method. Use of suitable NC guiding machines ensures a clean cut so that subsequent guiding of joint faces is almost eliminated. Firm will provide: technical know-how for the equipment, adaptation of casting and gating technology to the plasma arc cutting technique on the basis of documentation supplied, consultancy and cutting tests to ascertain suitability of castings for the operation. See illustration. Write: VEB MAW Stahlgießerei Magdeburg-Rothensee 301 Magdeburg, August-Bebel-Damm, East Germany and send copies of your initial correspondence to: Mr. Fritz Zschernig, General Director, Marketing and Development Department, GDR Central Licence Office, Schicklerstrasse 5-7, 102 Berlin, German Democratic Republic and to the: Commercial Division, Canadian Embassy, Matejki 1/5, Srodmiescle, Warsaw, Poland.

Process for the Manufacture of Self-levelling Anhydrite Mortar for Sub-floors and Slabs on Floors/287

A license is available from the German Democratic Republic. A flowable anhydrite binder is a new anhydritic construction material applied in liquid form to floors by means of pumps. It is made of natural or synthetic anhydrite and has self-levelling and quick-drying properties. It highly increases productivity in construction work. Write: VEB Leuna-Werke Walter Ulbricht, GDR 422, Leuna 3, East Germany, and send copies of your initial correspondence to: Berbauhandel, Otto-Nuschke-Strasse 55, GDR 108 Berlin, East Germany and to the: Commercial Division, Canadian Embassy, Matejki 1/5, Srodmiescle, Warsaw, Poland.

l'arc au plasma qui permet de découper les canaux d'alimentation et de sortie ainsi que les jets de coulée des moulages d'acier coulé au carbone, d'acier coulé allié à basse et à haute teneur. Pour les moulages de grande et de moyenne taille, l'arc au plasma sépare les sections transversales, les jets de coulée et les canaux d'alimentation. Ce procédé électronique offre des avantages énormes comparativement aux systèmes conventionnels de découpage manuel, notamment le découpage au chalumeau, l'oxycoupage à la poudre de fer et le découpage à la gouge. A ce titre, signalons les coûts de production inférieurs, une efficacité supérieure, une réduction du travail allant jusqu'à 90% pour l'affûtage des joints, des conditions de travail améliorées, une diminution des pertes de divers matériaux propres aux procédés de moulage particuliers, la possibilité d'effectuer plusieurs moulages en même temps – grâce à l'uniformité du procédé de centrage et de découpage, les différents genres de moulages ne subissent pas de pertes; la qualité de coupe répond aux normes de qualité des fonderies. Ce procédé permet de couper économiquement, en appliquant une technologie uniforme, les jets de coulée, les canaux d'alimentation, etc. d'acier coulé au carbone, d'acier coulé allié à haute teneur, de fonte, (GGG, GGV), d'aluminium coulé (G-A1) et de laiton coulé (G-Ms) d'une épaisseur allant jusqu'à 125mm (5"). L'emploi d'un appareil de guidage NC approprié assure une coupe nette, ce qui élimine presque le guidage subséquent des faces d'assemblage. La firme fournira les connaissances techniques concernant l'équipement, la technologie, l'adaptation du moulage et du découpage à la gouge à la technique du découpage à l'arc au plasma d'après la documentation fournie, les services d'experts-conseils et elle effectuera des tests de découpage pour vérifier la convenance des moulages pour l'opération. Voir l'illustration. Écrire à: VEB MAW Stahlgießerei Magdeburg-Rothensee, 301 Magdeburg, August-Bebel-Damm, Allemagne de l'Est et adresser des copies de votre correspondance initiale à: M. Fritz Zschernig, directeur général, Marketing and Development Department, GDR Central Licence Office, Schicklerstrasse 5-7, 102 Berlin, German Democratic Republic et à la: Division commerciale, Ambassade du Canada, Matejki 1/5, Srodmiescle, Varsovie, Pologne.

Procédé pour la fabrication de mortier anhydrite auto-nivelleur pour les planchers auxiliaires et les dalles de planchers/287

La République démocratique d'Allemagne offre une licence pour un sommier anhydrite écoulable, soit un nouveau matériau de construction anhydritique appliqué sous forme liquide aux planchers (au moyen de pompes). Il est fait d'anhydrite naturelle ou synthétique et possède des propriétés auto-nivelleuses et de séchage rapide. Il augmente considérablement la productivité dans le travail de construction. Écrivez à: VEB Leuna-Werke Walter Ulbricht, RDA 422, Leuna 3, Allemagne de l'Est et envoyez des copies de votre correspondance initiale à la: Berbauchandel, Otto-Nuschke-Strasse 55, RDA 108 Berlin, Allemagne de l'Est et à la: Division commerciale, Ambassade du Canada, Matejki 1/5, Srodmiescle, Varsovie, Pologne.

Manufacture of Finished Concrete Elements/287

A license is available from the German Democratic Republic on the forming and compressing of concrete and reinforced concrete elements by means of the implosion process which is free from negative side-effects found in current technology, e.g., the vibration system. It guarantees money-saving production of large as well as complicated concrete elements of correct form, density, surface characteristics and dimensional precision, as required. Write: Bauakademie der DDR, Plauener Strasse, GDR 1125, Berlin, East Germany and send copies of your initial correspondence to: Limex GmbH, Breitestrasse 12-17, GDR 102 Berlin, East Germany and to the: Commercial Division, Canadian Embassy, Matejki 1/5, Srodmiescle, Warsaw, Poland.

Perform-Contact Trays and Perform-Contact Grids/287

A license is available from the German Democratic Republic on perform-Contact Trays and Grids which represent a multi-faceted system of column trays as well as column filling in the processes of fluid and heat exchange in the chemical industry. This new development is characterized by excellent capacities and performance (high chargeability, low pressure losses, good separation effect) and finds increasing applications throughout the world. Write: VEB Maschinen-und Apparatebau Grimma, Chemieanlagenbaukombinat, Schulstrasse 63, Betrieb Germania Karl-Marx-Stadt, DDR 90 Karl-Marx-Stadt, East Germany and send copies of your initial correspondence to: Invest-Export, Johannes-Dieckmann-Str. 7-9, GDR 108 Berlin, East Germany and to the: Commercial Division, Canadian Embassy, Matejki 1/5, Srodmiescle, Warsaw, Poland.

Aeration Through Deep Irradiation/287

A license is available from the German Democratic Republic on a deep water aeration system which, by means of newly developed deep irradiation aerators made of corrosion-resistant, fibre-glass reinforced polyester, is used to stabilize oxygen contents of dam basins and other still waters. Write: Institut fuer Wasserwirtschaft, Schnellerstrasse 140, GDR 119 Berlin, East Germany and send copies of your initial correspondence to: Technocommerz GmbH, Mittelstrasse 25, GDR 108 Berlin, East Germany and to the: Commercial Division, Canadian Embassy, Matejki 1/5, Srodmiescle, Warsaw, Poland.

Automatic Flash-butt Welding Machine SAM 50/287

A license is available from the German Democratic Republic on an automatic flash-butt welding machine used for the continuous welding together of pre-heated rolling billets into endless ropes. The possibility which is thus afforded for endless rolling, alleviates the work to be performed by rolling mills. At the same time, productivity

Fabrication d'éléments de béton finis/287

La République démocratique d'Allemagne offre une licence pour le fromage et le pressage d'éléments de béton et de béton armé à l'aide d'un procédé d'implosion sans effets négatifs propre à la technologie courante, à savoir le système de vibration. Il garantit une production économique d'éléments de béton de grandes dimensions et compliqués avec toute la précision voulue en matière de forme, de densité, de caractéristiques de surface et de dimensions. Écrire à: Bauakademie der DDR, Plauener Strasse, RDA 1125, Berlin, Allemagne de l'Est et adresser des copies de votre correspondance initiale à: Limex GmbH, Breitestrasse 12-17, RDA 102 Berlin, Allemagne de l'Est et à la: Division commerciale, Ambassade du Canada, Matejki 1/5, Srodmiescle, Varsovie, Pologne.

Plateaux et grilles/287

La République démocratique d'Allemagne offre une licence visant les plateaux et les grilles. Ces plateaux et grilles appliquent un système polyvalent de plateaux à colonnes et de remplissage de colonnes intégré aux procédés d'échange des fluides et de chaleur dans l'industrie chimique. Cette invention présente les caractéristiques suivantes: possibilités et rendement excellents, (charges élevées, faibles pertes de pression, bon effet de séparation) et gagne de la popularité dans le monde entier. Écrire à: VEB Maschinen-und Apparatebau Grimma, Chemieanlagenbaukombinat, Schulstrasse 63, Betrieb Germania Karl-Marx-Stadt, RDA 90 Karl-Marx-Stadt, Allemagne de l'Est et adresser des copies de votre correspondance initiale à: Invest-Export, Johannes-Dieckmann-Str. 7-9, RDA 108 Berlin, Allemagne de l'Est, et à la: Division commerciale, Ambassade du Canada, Matejki 1/5, Srodmiescle, Varsovie, Pologne.

Aération par irradiation profonde/287

La République démocratique d'Allemagne offre une licence pour un système d'aération par eau profonde qui, au moyen d'aérateurs par irradiation profonde nouvellement mis au point et faits de polyester résistant à la corrosion et renforcé de fibre de verre, sert à stabiliser le contenu oxygéné des bassins de barrage et d'autres eaux calmes. Écrire à l'Institut fuer Wasserwirtschaft, Schenllerstrasse 140, RDA 119, Berlin, Allemagne de l'Est et envoyez des copies de votre correspondance initiale à: Technocommerz GmbH, Mittelstrasse 25, RDA 108 Berlin, Allemagne de l'Est et à la: Division commerciale, Ambassade canadienne, Matejki 1/5, Srodmiescle, Varsovie, Pologne.

Machine à souder bout à bout par étincelage automatique SAM 50/287

La République démocratique d'Allemagne offre une licence pour une machine à souder bout à bout par étincelage automatique servant à la soudure continue de billettes de laminage pré-chauffées en cordes sans fin. Cette possibilité de laminage sans fin allège les travaux effectués dans les laminiers. En même temps, la productivité est accrue et la ma-

is increased and raw material is saved. Write: Kombinat Lokomotivbau-Elektrotechnische Werke, GDR 1422 Hennigsdorf, East Germany and send copies of your initial correspondence to: Elektrotechnik, Alexanderplatz 6, Haus der Elektrotechnik, GDR 102 Berlin, East Germany and to the Commercial Division, Canadian Embassy, Matejki 1/5, Srodmiescle, Warsaw, Poland.

Process and Equipment for the Catalysis of Nitrous Gases/287

A license is available from the German Democratic Republic on a process and equipment developed because of the growing requirements of anti-pollutant measures in the country of the licensor. They were applied successfully in the chemical catalysis of toxic gases in a reducing atmosphere, by thermochemical means. Write: Kombinat VEB NARVA, Ehrenbergstrasse 11/14, GDR 1017 Berlin, East Germany and send copies of your initial correspondence to: Elektronik, Alexanderplatz 6, Haus der Elektrotechnik, GDR 102 Berlin, East Germany and to the: Commercial Division, Canadian Embassy, Matejki 1/5, Srodmiescle, Warsaw, Poland.

Overhead Cranes/287

American Research and Development organization offers a license to a Canadian company for the manufacture of "Reading Cranes" for sale in the Canadian and United States markets. Export rights can be extended to other areas. The firm will supply engineering, sales, technical input for both manufacturing, design and advertising assistance. The product is claimed to be generally accepted in the steel and aluminum industries as well as by the majority of heavy industrial users. The line has been expanded from standard industrial cranes of the heavy-duty variety to steel mill cranes of all types. Patterns for much of the standard crane line of equipment would be available to the licensee for securing castings of many items. Additional engineering requirements would be minimal. Write: Mr. A.R. Giblin, Vice President, Sales, Pollock Research & Design Inc., Dept. CN, 1200 High Street, Pottstown, Penn. 19464 and send a copy of your initial correspondence to: Canadian Consulate, 3 Parkway Building, Suite 1310, Philadelphia, Pennsylvania 19102.

Clothes Line Device/287

Canadian inventor offers to sell to a Canadian company his Canadian and American patent rights that were issued in 1979 for an expandable, removable clothes line device which can be slung between two opposite walls without nails, screws, suction cups or hooks. Based on the principle of yieldable stress between opposite ends of a bath

tière première économisée. Écrire à: Kombinat Lokomotivbau-Elektrotechnische Werke, RDA 1422 Hennigsdorf, Allemagne de l'Est et envoyez des copies de votre correspondance initiale à: Elektrotechnik, Alexanderplatz 6, Haus der Elektrotechnik, RDA 102 Berlin, Allemagne de l'Est et à la: Division commerciale, Ambassade du Canada, Matejki 1/5, Srodmiescle, Varsovie, Pologne.

Procédé et matériel de catalyse de gaz azoteux/287

La République démocratique d'Allemagne offre une licence pour un procédé et du matériel mis au point à cause des normes de plus en plus nombreuses concernant les mesures anti-pollution dans le pays du concédant. Ces mesures ont été appliquées avec succès à la catalyse chimique de gaz toxiques dans une atmosphère réductrice, par des méthodes thermochimiques. Écrire à: Kombinat VEB NARVA, Ehrenbergstrasse 11/14, RDA 1017 Berlin, Allemagne de l'Est et envoyer des copies de votre correspondance initiale à: Elektronik, Alexanderplatz 6, Haus der Elektrotechnik, RDA 102 Berlin (Allemagne de l'Est) et à la: Division commerciale, Ambassade du Canada, Matejki 1/5, Srodmiescle, Varsovie (Pologne).

Grues aériennes/287

Un organisme américain de recherche et de développement offre à une société canadienne la licence de fabrication des grues Reading pour vente sur les marchés canadien et américain. Les droits d'exportation peuvent être étendus à d'autres marchés. Cet organisme fournira des renseignements dans les domaines des techniques, de l'ingénierie et des ventes en vue d'aider à la conception, à la fabrication et à la publicité. Ce produit s'est valu, semble-t-il, une acceptation générale dans les industries de l'acier et de l'aluminium, de même que par la majeure partie de l'industrie lourde. L'éventail de produits, qui était constitué de grues industrielles normales pour gros travaux, comprend maintenant également tous les genres de grues pour aciéries. Le détenteur de la licence aura accès aux modèles pour la plupart des grues standard, ce qui lui permettra d'obtenir des moulages pour plusieurs articles avec un minimum de travaux d'ingénierie supplémentaires. Pour plus de renseignements, écrire à: M. A.R. Giblin, Vice Président, Sales, Pollock Research & Design Inc., Dept. CN, 1200 High Street, Pottstown, Penn. 19464 et transmettre une copie de votre correspondance initiale au: Consulat du Canada, 3 Parkway Building, Suite 1310, Philadelphia, Pennsylvania 19102.

Support de corde à linge/287

Un inventeur canadien offre de vendre à une société canadienne ses droits de brevet au Canada et aux États-Unis qui lui ont été délivrés en 1979 pour un support de corde à linge extensible et amovible qui peut être installé entre deux murs, sans clous, vis, ventouses ou crochets. Issu du principe de la limite élastique entre deux murs au-dessus de

wall indoors, or between a balcony railing or a building wall outdoors, the clothes line includes a rod with heads fixed to each end formed of low-shaped wire work having concave sides facing the corresponding wall and engaging the latter in two stages; the first stage being sufficient to support the clothes line device but allowing it to be shifted to the desired position and the second stage tightening it to operatively support the clothes. Some volume production and sales have taken place. Write: Mr. Roland Gauthier, 100 Place Springdale, # 114, Dollard des Ormeaux, Quebec H9B 1N5 and send a copy of your initial correspondence to: Licensing Opportunities Section (34/3), Business Centre, Department of Industry, Trade and Commerce, Ottawa, Ontario K1A 0H5.

Potato Sorting Equipment/287

Swiss company seeks a Canadian manufacturer to finance the prototype development work from jointly established specifications for a potato sorting machine on which it will grant exclusive worldwide manufacturing and marketing rights in exchange for an initial cash payment and royalties. The equipment works by aligning, for example, stones and potatoes in a row which are then distributed one by one so that they fall on sloping plates situated just below rolling dispensers. The objects are identified by measuring their impact on plates equipped with vibrator castors, which inform an electronic analyser to differentiate between potatoes and stones. The separation of stones is made by ejection. The analyser commands the start of a mechanical amplifier which starts working almost instantaneously by lifting and moving backwards, a motion which provokes the ejection of the stones at a sufficient speed to give them a trajectory different from that of the potatoes which simply rebound on the plate. Potatoes and stones are therefore received on different channels. In the latest conception, the motion is provoked by a pneumatic system instead of the mechanical amplifier. A fixed installation with 13 channels is in service in Hannover (Germany) for a regional sorting center. This machine sorts 20 to 30 tons per hour. See illustration. Write: Dr. N. Wavre, ETEL S.A., 56, avenue de Préfaully, CH-1020, Renens, Switzerland and send a copy of your initial correspondence to: Commercial Division, Canadian Embassy, Kirchenfeldstrasse 88, 3005 Berne, Switzerland.

Panel Carrier/287

Licensing agent acting on behalf of a Canadian inventor offers exclusive licensing rights in Canada to manufacture and market a device which permits the carrying of panels by one person. It includes a platform of elongated configuration, a flange projecting from the front face and a single

la baignoire à l'intérieur, ou de rampes de balcon ou de murs au-dessus de la baignoire à l'intérieur, ou de rampes de balcon ou de murs à l'extérieur, le support comprend une tige dont les bouts en fils métalliques sont disposés en forme d'arc; la face concave au bout fait face au mur. L'appareil est fixé au mur en deux étapes: d'abord le support est fixé au mur (il peut se tenir de lui-même), mais on peut le déplacer pour corriger sa position; en deuxième lieu, on peut le resserrer pour le fixer définitivement au mur et y suspendre du linge. Un certain nombre de ces supports a été fabriqué et vendu. Écrire à: M. Roland Gauthier, 100, Place Springdale, app. 114, Dollard-des-Ormeaux (Québec) H9B 1N5, et envoyer une copie de votre correspondance initiale à la: Section des possibilités de licences (34/3), Centre des entreprises, ministère de l'Industrie et du Commerce, Ottawa (Ontario) K1A 0H5.

Machine à trier les pommes de terre/287

Une société suisse cherche un fabricant canadien pour le financement du travail de mise au point, à partir de spécifications déterminées conjointement, du prototype d'une machine à trier les pommes de terre pour laquelle il accordera les droits exclusifs de fabrication et de commercialisation à l'échelle mondiale, en échange d'un paiement initial en espèces et de redevances. La machine fonctionne de cette façon: il faut, par exemple, aligner un mélange de pierres et de pommes de terre; ces objets sont alors distribués individuellement et tombent sur des plaques inclinées disposées en dessous des distributeurs roulants. Les objets sont alors identifiés d'après la mesure du choc qu'ils produisent sur les plaques munies d'un capteur qui transmet l'information à un analyseur électronique, lequel détermine si l'objet est une pomme de terre ou une pierre. Les pierres sont éjectées. L'analyse commande la mise en marche d'un amplificateur mécanique qui commence à fonctionner presque instantanément en se soulevant et en reculant, ce qui provoque l'éjection des pierres à une vitesse suffisante pour leur donner une trajectoire différente de celle des pommes de terre qui ne font que rebondir sur la plaque. Les pommes de terre et les pierres s'acheminent ensuite vers des canaux différents. Dans le dernier modèle, le mouvement est provoqué par un système pneumatique au lieu d'un amplificateur mécanique. Une installation fixe comprenant 13 canaux fonctionne actuellement à Hanovre (Allemagne) dans un centre régional de tri. Cette machine effectue le tri de 20 à 30 tonnes de pierres et pommes de terre par jour. Voir l'illustration. Écrire à: M. N. Wavre, ETEL S.A., 56, avenue de Préfaully, CH-1020, Renens, Suisse et adresser une copie de votre correspondance initiale à la: Division commerciale, Ambassade du Canada, Kirchenfeld-strasse 88, 3005 Berne, Suisse.

Porte-Panneaux/287

Un agent, qui représente un inventeur canadien, offre les droits exclusifs de fabrication et de commercialisation au Canada d'un dispositif qui permet à une personne de transporter facilement des panneaux. Cet appareil comprend une plate-forme allongée avec semelle et poignée simple. La

handle. The tool's elongated configuration is bent so that each end extends away from the other at an angle greater than 180° making the tool easy to grip and preventing it from being awkward to use and the panels from slipping off. Write: Martin J. Marcus, Esq., Marcus & Associates, 130 Slater Street, Suite 500, Ottawa, Ontario K1P 5H6 and send a copy of your initial correspondence to: Licensing Opportunities Section (34/3), Business Centre, Department of Industry, Trade and Commerce, Ottawa, Ontario K1A 0H5.

Dry Wall Holder/287

Licensing agent acting on behalf of a Canadian inventor offers the exclusive licensing rights in Canada to manufacture and market his patented support assembly for lifting, aligning and holding dry wall panels during installation. This is a single support provided with upper and lower telescopically arranged elongated tubular sections with locking means, a hand grip and a flat elongated platform having an upwardly projecting flange at one edge. Resilient means are provided for biasing the flange to project from the front face of the platform and for permitting the flange to move, against a resilient biasing force, into a position wherein it is substantially flush with the front face of the platform. The device can be operated by one person. Small production runs have taken place. Write: Martin J. Marcus, Esq., Marcus & Associates, 130 Slater Street, Suite 500, Ottawa, Ontario K1P 5H6 and send a copy of your initial correspondence to: Licensing Opportunities Section (34/3), Business Centre, Department of Industry, Trade and Commerce, Ottawa, Ontario K1A 0H5.

"Windbreaker" Kit/287

Licensing agent acting on behalf of a Canadian inventor offers the worldwide licensing rights to a Canadian company for the manufacture and sale of a storm window kit under the "Windbreaker" trade mark. A vinyl sheet with a hook and loop fastener secured to a pressure sensitive backing strip has the hook strip secured to the window frame and the loop strip to the vinyl sheet. Upon engagement of the loop strip to the hook strip a secure but adjustable closure or storm window is provided. Write: Martin J. Marcus, Esq., Marcus & Associates, 130 Slater Street, Suite 500, Ottawa, Ontario, K1P 5H6 and send a copy of your initial correspondence to: Licensing Opportunities Section (34/3), Business Centre, Department of Industry, Trade and Commerce, Ottawa, Ontario K1A 0H5.

Fluid Metering Device/287

American licensing broker acting on behalf of the inventor, R.E. Clarke, offers the licensing rights for the manufacture and sale of a Flo-Control Automatic Fluid Metering Device, U.S. Patent Number 3,497,106. This flo-control gauge is a new concept in gasoline sales intended as a convenience to

plate-forme est courbée de telle façon que chaque extrémité s'étend en sens opposé à un angle de plus de 180 degrés. Ainsi l'utilisateur a une meilleure prise et peut manipuler plus facilement le panneau. Cette caractéristique empêche aussi le glissement du panneau. Écrire à: M. Martin J. Marcus, Marcus & Associates, 130 rue Slater, bureau 500, Ottawa (Ontario) K1P 5H6 et envoyer une copie de votre correspondance initiale à: Section des possibilités de licences (34/3), Centre des entreprises, ministère de l'Industrie et du Commerce, Ottawa (Ontario) K1A 0H5.

Porte-panneaux muraux/287

Un agent, représentant un inventeur canadien, offre les droits exclusifs de fabrication et de commercialisation au Canada de son support breveté pour lever, aligner et tenir en place les panneaux muraux pendant leur installation. Cet appareil comporte des sections tubulaires télescopiques inférieures et supérieures avec dispositif de verrouillage, poignée, ainsi qu'une plate-forme allongée avec semelle. On peut décentrer la semelle pour qu'elle déborde la face frontale du panneau ainsi que la déplacer dans une position où elle sera à niveau avec la face frontale du panneau mural. Une personne seule peut utiliser l'appareil. On a déjà fabriqué un nombre limité de ces appareils. Écrire à: M. Martin J. Marcus, Marcus & Associates, 130 rue Slater, Bureau 500, Ottawa (Ontario) K1P 5H6 et envoyer une copie de votre correspondance initiale à: Section des possibilités de licences (34/3), Centre des entreprises, ministère de l'Industrie et du Commerce, Ottawa (Ontario) K1A 0H5.

Ensemble "Windbreaker"/287

Un agent, qui représente un inventeur canadien offre à une société du Canada les droits mondiaux de fabrication et de commercialisation d'un ensemble de contre-fenêtre dont la marque de commerce est "Windbreaker". Ce nécessaire comprend une feuille de vinyle, munie d'une attache à boucle et crochet fixé à une bande de renforcement autocollante. La bande à crochet est fixée au châssis de fenêtre et la bande à boucle à la feuille de vinyle. Une fois que la bande à boucle adhère bien à la bande à crochet on dispose d'une contre-fenêtre bien fixée mais ajustable. Écrire à: M. Martin J. Marcus, Marcus & Associates, 130 rue Slater, Bureau 500, Ottawa (Ontario), K1P 5H6 et envoyer une copie de votre correspondance initiale à: Section des possibilités de licences (34/3), Centre des entreprises, ministère de l'Industrie et du Commerce, Ottawa (Ontario) K1A 0H5.

Débitmètre/287

Un courtier en licences américain a été chargé par l'inventeur, R.E. Clarke, d'offrir les droits de fabrication et de vente, sous licence, d'un appareil automatique de mesure du débit des fluides (brevet américain 3 497 106). L'appareil applique un nouveau concept pour la vente de l'essence, très

the gasoline pump attendant to facilitate efficiency, speed and to increase gasoline sales. It is easily installed in minutes on existing equipment at nozzle point or at pump outlet to deliver any required amount of gasoline, whether in dollars, gallons or litres. The device will shut off automatically when the requested amount is delivered, allowing attendant to take care of many customers simultaneously. It also has a "fill up" feature. By pulling a dial knob to "up" position, the flo-control gauge is non-functioning, allowing the attendant to rely on automatic nozzle for shut off. The flo-control is sturdily constructed, having die-cast housing and Delrin plastic gears impervious to gasoline and other high octane fluids; waterproof housing; small and compact in size - 9.42 mm (3 3/4") diameter, 6.25 mm (2 1/2") deep; can be used with any low viscosity fluid, heating fuel, aircraft petroleum, kerosene, etc., and does not interfere with pump metering scale. Write: Mr. Frank Brkic, Mosaic enterprises Inc., P.O. Box 3786, Washington, D.C. 20007 and send a copy of your initial correspondence to: Canadian Consulate, 3 Parkway Building, Suite 1310, Philadelphia, Pennsylvania 19102.

Hovercraft/287

Finnish inventor, Mr. Esko Hietanen, offers a Canadian company exclusive worldwide manufacturing and marketing rights to his patented "Amficat" hovercraft which has been designed for varied transport needs in archipelagos throughout the year, and especially in the difficult seasons wherein both ice, snow and open water and rapidly changing weather conditions are prevalent. The operating of the hovercraft is based on a new technique that improves steerability and control of the vehicle in very difficult ices, water and wind conditions. The construction of the hovercraft is based on using a fixed-pitch propeller in front of the driver's and passengers' cabin. The hovercraft is steered by gutter-like steering blades pivoted on the sides of the cabin and by side rudders in the rear part of the cabin. The side blades can be turned separately, in order to make the steering more effective, or simultaneously to an angle of 90° whereby they act as an effective brake. In order to guide the propeller stream, there are two stationary horizontal plates on the roof of the cabin. The hovercraft is also capable of driving backwards by turning the side blades to the vertical position, whereby the propeller stream is turned forward with the aid of the stationary plates. A prototype has been in use as a taxi for the last few years. Plans for a larger ten seat craft will be included in the license. See illustration. Write: Mr. Carl-Magnus Fogelholm, Licensing Engineer, Keksintösäätiö, Atomitie 5 C, SF-00370 Helsinki 37, Finland and send a copy of your initial correspondence to: Commercial Division, Canadian Embassy, Pohjois Esplanadi 25B, 00100 Helsinki 10, Finland.

commode pour les pompistes. Ses caractéristiques: efficacité, rapidité et augmentation des ventes d'essence. Il s'installe en très peu de temps sur l'équipement en place (dans le tuyau, au niveau du bec ou à la sortie du distributeur). Il permet de distribuer la quantité voulue d'essence en dollars, en gallons ou en litres. L'appareil s'arrête automatiquement lorsque la quantité requise est versée; ainsi le pompiste peut s'occuper de plusieurs clients à la fois. Une autre caractéristique: le réglage du remplissage. Lorsqu'on tire le bouton du cadran, le débitmètre ne fonctionne pas et le pompiste peut se fier au bec automatique pour l'arrêt de l'opération. Le corps de l'appareil solide est en métal coulé sous pression et étanche. Il comporte un mécanisme en plastique Delrin inattaquable par l'essence et les autres fluides à indice d'octane élevé. L'appareil se caractérise par son faible volume et sa compacité (3 3/4" ou 9,42 mm de diamètre, 2 1/2" ou 6,25 mm de profondeur). Il peut servir avec tout fluide de faible viscosité, (huile à chauffage, carburant d'avion, kérosène, etc.) et ne gêne aucunement l'action du compteur du distributeur. Écrire à: M. Frank Brkic, Mosaic Enterprises Inc., P.O. Box 3786, Washington D.C. 20007 et envoyer une copie de votre correspondance initiale au: Consulat du Canada, 3 Parkway Building, Suite 1310, Philadelphie, Pennsylvanie 19102.

Aéroglesseur/287

Un inventeur finlandais, M. Esko Hietanen, offre à une société canadienne les droits mondiaux exclusifs de fabrication et de commercialisation de son aéroglesseur breveté "Amficat", qui a été conçu pour répondre à divers besoins en matière de transport dans les archipels, durant toute l'année et, en particulier au cours des rudes saisons où se mêlent glace, neige et eau et lorsque les conditions climatiques changent rapidement. L'aéroglesseur fait appel à une nouvelle technique qui en accroît la maniabilité et le contrôle dans la glace, l'eau et le vent. Il comprend une hélice à pas fixe située à l'avant de la cabine du conducteur et des voyageurs. Il est dirigé à l'aide de plaques de direction en forme de gouttières se trouvant sur les côtés de la cabine et de stabilisateurs latéraux situés à l'arrière de la cabine. Les plaques latérales peuvent être tournées séparément de manière à assurer une meilleure direction, ou ensemble à 90° pour permettre un freinage efficace. Pour orienter l'air provenant de l'hélice, deux plaques horizontales fixes sont situées sur le toit de la cabine. L'aéroglesseur peut également faire marche arrière; il suffit de placer les plaques latérales à la verticale: ainsi, le courant d'air provenant de l'hélice est dirigé vers l'avant à l'aide des plaques fixes. Depuis quelques années, un prototype sert de taxi. Les plans d'un plus gros aéroglesseur (10 places) seront fournis avec la licence. Voir l'illustration. Écrire à: M. Carl-Magnus Fogelholm, ingénieur responsable des licences, Keksintösäätiö, Atomitie 5 C, SF-00370 Helsinki 37, Finlande et faire parvenir une copie de votre correspondance initiale à la: Division commerciale, Ambassade du Canada, Pohjois Esplanadi 25B, 00100 Helsinki 10, Finlande.

RÉSUMÉS OF THE FOLLOWING CANADIAN PATENTS AND UNITED STATES PATENT APPLICATIONS AVAILABLE FOR LICENSING ARE PUBLISHED IN THE LANGUAGE OF APPLICATION, ENGLISH OR FRENCH.

DES RÉSUMÉS DES BREVETS CANADIENS CI-JOINTS ET DES DEMANDES DE BREVETS AMÉRICAINS POUR L'OCTROI DE LICENCES SONT PUBLIÉS DANS LA LANGUE DE LA DEMANDE DE BREVET, EN ANGLAIS OU EN FRANÇAIS.

Digital Display Member

1,060,567/287

Dispositif d'affichage numérique

An improved digital display device is provided. It includes (a) three spaced-apart surfaces; (b) five non-identical segments associated with such surfaces, the segments being activatable by energy to be optically visible, two said spaced apart surfaces being opposite faces of a transparent substrate, and at least one segment being disposed on each face of said transparent substrate and (c) means selectively activatable to supply activating energy to one or more of the segments, thereby to provide a visible representation of a selected alpha-numeric element. This type of structure minimizes the electrical connection and simplifies the construction. Write: Maurice P. Van der Meer, Marcus and Associates, Box 8721, Ottawa, Ont. K1G 3J1.

Shopping Cart

1,063,642/287

Poussette

A shopping cart comprises a U-shaped frame having a pair of spaced parallel sides and a head joining the sides and perpendicular thereto and functioning as the handle of the cart. Each of the sides has a plurality of spaced holes formed therethrough parallel in direction to the head. An axle is mounted at the ends of the sides of the frame opposite and parallel to the head. A pair of wheels is rotatably mounted on the axle, a pair of support members of inverted L-shape is affixed to a corresponding side of the frame in the area of the axle, to support the frame in upright position on a supporting surface. A basket-type member with each of two corner members partially surrounds a corresponding side of the frame and a hole passing therethrough in alignment with the holes through the side. The basket-type member is slidably mounted on the frame. Each of a pair of pins is positioned through the hole of a corresponding corner member of the basket-type member and through a selected hole through the corresponding side of the frame thereby releasably maintaining the basket-type member in a selected position above a surface supporting the cart. Write: Alice Green, 11978 Heritage Circle, Downey, California 902-41, U.S.A.

Method of Recovering Substances in the Extraction of Spent Liquors from the Delignification of Lignocellulosic Material by Means of Chloride-Producing Bleaching Agents

1,064,206/287

Méthode de récupération de substances par l'extraction de solutions usées de la délignification de matières lignocellulosiques au moyen d'agents de blanchiment générateurs de chlorure

Lignocellulosic fibrous materials are delignified in two or more stages. An introductory stage of digestion discharges brown stock and a black liquor which contains i.a. sulphur compounds wherein sulphur has an oxidation number that equals either -II (e.g. Na_2S) or IV (e.g. Na_2SO_3). Optionally, the brown stock is further delignified by means of oxygen, whereby oxystock and oxyliquor are obtained. Stock from digestion, i.e. brown stock or oxystock, is subjected to delignifying oxidative bleaching using chlorine or chlorine compounds, the reaction products of which subsequently form chlorides in the bleaching effluent. The non-chloride liquors, i.e. black liquor and oxyliquor, possibly also a low chloride fraction of bleaching effluents, are joined to form a lye which is recovered and combusted and includes the major part of the sulphur compounds used for digestion. The lye combustion furnace releases compounds comprising sulphur of oxidation number -II and IV. The chloride forming effluents, optionally including a minor lye fraction, are combined to form a brine which is subjected to another combustion which principally produces chlorides and compounds of sulphur of oxidation number IV (e.g. SO_2) and VI (e.g. SO_3 and Na_2SO_4). This makes it possible to eliminate sulphur compounds, e.g. sulfidic compounds with oxidation number -II, from the brine recovery operations including separation of chloride, while the digestion chemical recovery system only handles the lye. By this means the digestion as well as the entire pulp mill system is relieved from chlorides, however, at least two combustion furnaces and two separate evaporation lines, one for lye and one for brine, are required. The combined water evaporation from lye and brine can be kept on the same level as for a conventional single-line black liquor operation because brine substitutes wash water. Write: Nils V. Mannbro, Askaremala, S-290 72 Asarum, Sweden

Apparatus for Forming a Sheet

1,064,294/287

Appareil pour façonner des feuilles

An apparatus comprising a first and a second endless wire for making a forming zone between mutually converging wires; a feed box with lips forming an outlet opening for feeding fibre suspension into the gap of the forming zone between the wires, the first wire being in tight contact with the first lip of the feed box, the second wire being in tight contact with the other lip of the

feed box, and on both sides of the forming zones parallel side walls being arranged for tightening both sides of the forming zone against the wires; and rolls for guiding the wires, whereby the second wire is, at least along the sheet forming zone, arranged to run along the surface of a wire cylinder equipped with suction devices, whereby the first wire, which is guided from a breast roll arranged on the opposite side of the feed box relative to the wire cylinder, is, arranged to run carried by the sheet to be formed along the surface of the wire cylinder. Write: Oy Tampella AB, Tampere, Finland

Dispositif de sécurité pour l'obturation d'une canalisation, 1,064,346/287
notamment pour réservoir d'hydrocarbures de véhicules automobiles

Safety Closing Device for Piping, Namely for Vehicle Gas Tanks

L'invention se rapporte à un dispositif de sécurité pour l'obturation d'une canalisation, notamment d'un réservoir de carburant pour véhicule automobile. Il comporte un manchon extérieur traversant la paroi du réservoir à laquelle il lui est solidarisé, un ensemble tubulaire susceptible de coulisser dans le manchon. Cet ensemble est constitué sur une partie de sa longueur d'une partie pleine, qui se termine du côté interne au réservoir par une butée et d'une partie tubulaire, débouchant d'une part hors du réservoir et d'autre part au droit d'une ouverture latérale ménagée dans le manchon. Écrire: Compagnie des Produits Industriels de l'Ouest, Zone Industrielle de Nantes-Carquefou B.P. 1226-44023 Nantes Cedex, France

Apparatus to Protect the Breathing of a Horse

1,064,364/287

Appareil pour protéger les naseaux des chevaux

The breath protector is adapted to be worn by trotters and pacers and includes a self-supporting cover and a means for mounting the cover between a position over the muzzle for a horse and a position spaced from the muzzle of the horse. A release means for releasing the cover from about the muzzle is actuated by the driver via a cable which extends over the head of the horse. A suitable locking means is provided under the horse's head to secure the cover in the retracted position. Write: Francis Doino, Jr., 277 E. Barkley Place, North Brunswick, New Jersey 08902, U.S.A.

Electrostatic Air Cleaner

1,064,407/287

Épurateur d'air électrostatique

An electronic air cleaning assembly wherein the collector plates are of identical configuration for both the high voltage and grounded plates. The collector plates are provided with clearance holes of a generally circular shape and spacing holes of a generally rectangular shape. The plates are spaced and supported by tube members having a diameter approximately equal to the width of the rectangular holes. Each tube is provided with a series of spaced slots extending partly therethrough and of a width for engaging one side wall of a rectangular hole in alternate plates thereby spacing and holding the plates in fixed relationship to one another. A doubled corona charging wire arrangement is also provided wherein a continuous length of wire is used in forming the ionizing section of the electrostatic air cleaner but each cooperative pair of wires is tensioned by an individual tensioning spring. Write: Chemtool, Inc., 14914 Minnetonka Blvd., Minnetonka, Minnesota 55343, U.S.A.

Dispositif de sécurité pour l'aération d'un réservoir de carburant 1,064,416/287

Safety Device for the Ventilation of a Fuel Tank

L'invention concerne un dispositif de sécurité pour l'aération d'un réservoir de carburant, notamment pour véhicule automobile. Ce dispositif est constitué par une membrane en un élastomère naturel ou artificiel résistant aux hydrocarbures, percée de fentes, maintenue entre les rebords de deux éléments cylindriques, concentriques, constituant un corps de clapet, un jeu étant prévu entre la membrane et les rebords qui l'encadrent de façon à éviter que ces derniers soient la source de contraintes dans ladite membrane, ce qui entraînerait la déformation des fentes et modifierait de façon imprévisible le débit gazeux qui les traverse. Il est utilisable pour les réservoirs d'essence. Écrire: Régie Nationale des Usines Renault, 8/10 Avenue Émile Zola, 92109 Boulogne-Billancourt, France

Rope Guide and a Hoist Comprising the Guide

1,064,454/287

Guide-câble et treuil combinés

A rope guide for guiding a rope being wound onto, or unwound from, a drum includes several sectors, preferably three, which are connected together to form a ring adapted to surround the drum and turns of rope on the drum, and means for urging at least one of the sectors towards the drum. The sectors are provided with a number of seatings in each of which there is mounted a rotatable rope-engaging member, preferably a ball or a barrel-shaped roller. One of the sectors is provided with a slot for the entry of a rope into the guide, this slot having side walls which converge in the radially-inward direction. A hoist is claimed which incorporates the rope guide for guiding the rope of the hoist as it is wound onto or from the hoisting drum. Write: Stoil M. Tcholakov, Sofia-73, Boulevard Suhodolska 1, Block 8, Entrance 2, Bulgaria

Switching Circuit**1,064,632/287****Circuit de commutation**

A switching circuit comprises an operational amplifier with two resistive negative feedback paths including respective unilaterally conducting devices (e.g. diodes) connected in opposite polarity to the output of the amplifier. A first terminal is connected to the electrode of the unilaterally conducting device in one path remote from the output of the amplifier, and a second terminal is connected to the electrode of the unilaterally conducting device in the other path remote from the output of the amplifier. Signals of one polarity only applied to the first terminal appear at the second terminal and signals of the opposite polarity only applied to the second terminal appear at the first terminal. The circuit may include three or more such feedback paths. The values of the resistors in the feedback paths may be adjusted to change the transfer gain of the circuit. The circuit is of particular value in a telephone conference amplifier using unilateralised signals for connecting each channel to a point common to the channels. Write: The Post Office, 23 Howland Street, London, W1P 6HQ, England, U.K.

Method for Manufacturing of Packaging-Container Blanks**1,064,663/287****Méthode de fabrication d'ébauches d'emballages**

A method of manufacturing packaging-container blanks which includes forming a substantially continuous sheet of blanks which comprise a substrate with a coating material attached. The coating material at the edges either extends beyond the substrate or is unattached to the substrate adjacent the edge, or both. The sheet of blanks is manufactured by extruding a molten thermoplastic coating material onto the substrate between two revolving cylindrical rolls. The substrate and the coating material are joined in such a manner that at spaced, selected intervals, elongated zones are provided where they are unattached to each other. These unattached zones include zones extending transversely with respect to the sheet of blanks and which transversely extending unattached zones are produced by grooves on the periphery of at least one of the rolls which grooves are suitably arranged at intervals about the periphery of the roll to correspond to the pre-selected unattached zones desired. The substrate is perforated transversely within the unattached zones so that it may be parted after the coating material is applied by means of a longitudinal jerk. The coating material is cut along the zones by means of blades arranged in the grooves on the grooved roll. Such blades arranged in the grooves may also be used to cut the substrate if desired rather than using the perforated-jerk arrangement. Longitudinally extending unattached zones are also contemplated. Also disclosed is an apparatus for performing the above method. Write: Pekema Oy, Teollisuuskatu 20, 00510 Helsinki 51, Finland

Process for Ortho-para-hydrogen Conversion**1,064,679/287****Procédé pour l'interconversion ortho-para de l'hydrogène**

The present invention provides in a process for ortho-para-hydrogen conversion in the presence of a catalyst the improvement in which the catalyst is a sulphur-containing semi-conductive polymer obtained by the dehalogenation of poly (tetrahalophenylene sulphides). Write: Japan Synthetic Rubber Company Limited, 1, Kyobashi 1-chome, Chuo-ku, Tokyo, Japan

Procédé de préparation de pièces en alumine beta alcaline**1,064,686/287****Fabrication Process for Parts Made of Alkaline Beta Alumina**

Procédé de préparation de pièces en alumine bêta alcaline consistant à mélanger de l'alumine et un carbonate alcalin en quantités prédéterminées, à chauffer ce mélange, à broyer après refroidissement à mettre en forme les pièces, à les fritter, caractérisé par le fait qu'après ladite mise en forme on effectue sur la surface des pièces en contact avec l'atmosphère un dépôt d'un composé dudit métal alcalin. L'invention est mise en oeuvre pour réaliser des pièces utilisées comme électrolyte solide dans des générateurs électrochimiques du type sodium-soufre. Écrire: Compagnie Générale d'Electricité S.A., 54 rue La Boétie, 75382 Paris Cedex 08, France

Ferric Ion as a Scavenging Agent in a Solvent Extraction Process**1,064,707/287****Ions ferriques utilisés comme agents épurateurs dans un procédé d'extraction par solvant**

Ferric ions are added into the aqueous feed of a plutonium scrap recovery process that employs a tributyl phosphate extractant. Radiolytic degradation products of tributyl phosphate such as dibutyl phosphate form a solid precipitate with iron and are removed from the extraction stages via the waste stream. Consequently, the solvent extraction characteristics are improved, particularly in respect to minimizing the formation of nonstrippable plutonium complexes in the stripping stages. The method is expected to be also applicable to the partitioning of plutonium and uranium in a scrap recovery process. Write: United States Department of Energy, Washington, D.C. 20545, U.S.A.

Extendable, Retractable and Portable Shelter

1,064,800/287

Abri extensible, rétractable et portable

An enclosure with doors contains a plurality of arched hoops or the like having ground engaging skids and with a flexible covering attached thereto. The hoops may be pulled out manually over a car or the like parked in front of the enclosure. Locking bars lock the hoops in spaced apart relationship automatically and a bar may be provided hooking under the bumper of the car for anchoring purposes. A winch in the enclosure winds cables passing through eyes on the hoops or arches and which are anchored to the outermost arch. Means are provided to break the over-center locking action of the locking bars as the hoops are wound in by the winch until the entire assembly is contained within the enclosure. Write: Anne Ryce, 5D-1975 Corydon Avenue, Winnipeg, Manitoba R2P 0R1, Canada

Skis with Convex Running Surfaces and Downwardly Projecting Edges

1,064,981/287

Skis à surfaces glissantes convexes et à lames saillantes vers le bas

Skis in which resistance to turning is reduced and grip is improved by providing a running surface having a shape along at least substantially its whole length such that in cross-section at right angles to the longitudinal axis of the ski the surface is predominantly convex across its width and, at the boot position, running along a part of each side of the ski, elongated blades positioned at least substantially symmetrically in relation to the boot position along the ski, the blades being parallel to the longitudinal axis of the ski and each blade projecting downwards from the sides of the ski by a distance substantially the same as the maximum projection of the running surface below the sides of the ski. Write: Howard Ford, Les Abeilles, Boulevard d'Italie, Monte Carlo, Monaco

Substance and Device for the Absorption of Catalyst Poisoning Gases Out of the Oxyhydrogen Gas Mixture

1,065,012/287

Méthode et substance pour absorber les gaz toxiques dans un mélange oxyhydrogénique gazeux

A substance, a method of producing it, and a device for using the substance in the absorption of catalyst poisoning gases out of the oxyhydrogen gas mixture produced by lead-acid storage batteries, the substance effecting the oxidation of the unstable catalyst poisoning gases SbH_3 and AsH_3 to produce hydrolysis-resistant intermetallic compounds. As absorbing substances are usable heavy-metal manganites, heavy-metal oxides and catalytic agents. As a device, the absorbing substance is combined with an oxygen and hydrogen recombination unit. Write: Accumulatorenwerk Hoppecke Carl Zoellner & Sohn, Barbarossaplatz 22, 5000 Cologne, Germany

Method of Preparing an Electrochemical Cell in Uncharged State

1,065,013/287

Méthode de préparation d'une cellule électrochimique à l'état non chargé

A secondary electrochemical cell is assembled in an uncharged state for the preparation of a lithium alloy-transition metal sulfide cell. The negative electrode includes a material such as aluminum or silicon for alloying with lithium as the cell is charged. The positive electrode is prepared by blending particulate lithium sulfide, transition metal powder and electrolytic salt in solid phase. The mixture is simultaneously heated to a temperature in excess of the melting point of the electrolyte and pressed onto an electrically conductive substrate to form a plaque. The plaque is assembled as a positive electrode within the cell. During the first charge cycle lithium alloy is formed within the negative electrode and transition metal sulfide such as iron sulfide is produced within the positive electrode. Write: United States Department of Energy, Washington, D.C. 20545, U.S.A.

Method for Bleaching of Material Containing Cellulose

1,065,105/287

Méthode de blanchiment de matières contenant de la cellulose

An improved method of bleaching cellulosic material with an oxidizing gas in an alkaline environment in which a pulp suspension is treated with an alkali solution at an elevated temperature and pressure in the presence of an oxidizing gas to effect removal of lignin wherein the improvement comprises transforming the pulp suspension into a stable foam in the presence of a foaming agent. Write: A. Ahlström Osakeyhtiö, Noormarkku, Finland

Methods and Apparatus for Coating Filaments

1,065,137/287

Appareil et méthode d'enrobage de filaments

This invention relates to a method which facilitates the production of covered filament in that it enables a covering to be applied to a filament at a speed compatible with the speed of filament production, and which permits substantial increases in the rate of production of covered filament. The method comprises the steps of pulling the filament from a melt of filament material, applying longitudinally at least one protective tape covering to the filament to envelope the latter, applying heat to the tape(s), and closing the envelope longitudinally. Write: Post Office, 23 Howland Street, London, W1P 6HQ, England

All Purpose Concrete Foundation Block**1,065,148/287****Bloc en béton tout usage pour fondations**

This patent application covers the design of an all purpose concrete foundation block which stabilizes and anchors all types of portable buildings, trailers and objects. This invention is a precast, steel re-inforced concrete block which securely attaches to the underframe of the building, trailer home or object and permits a liquid concrete pour through the centre of the concrete block. The liquid concrete poured through the centre of the precast foundation block fills the pre-dug hole in the ground and the recessed centre of the precast block. Write: Gungho Developments Limited, P.O. Box 132, Two Hills, Alberta T0B 4K0, Canada

Epicyclic Cog Belt Speed Reducer**1,065,163/287****Réducteur de vitesse pour courroie crantée épicycloïdale**

Mechanical apparatus for reducing angular speed, commonly known as speed reducers, known as a planetary type reducer with a very high reduction ratio; in the order of 1000:1 and higher, having concentric input and output shafts, on each of which is fixed a sun cogwheel; there is a third sun cogwheel, also on the main axis, which is fixed to the frame. The speed reduction ratio is dependent mainly on the difference in the relative sizes and number of teeth, of the output sun wheel and the fixed sun wheel; when there is zero difference, the reduction ratio is infinite. Chains and sprocket wheels can be used in place of cog belts and cogwheels in applications where maximum output torque is required. Write: Frank L. Stromotich, 4625 Piccadilly Road North, West Vancouver, British Columbia, V7W 1E3, Canada

Oil Recovery Fluids Selected Using Nuclear Magnetic Resonance Measurements**1,065,248/287****Sélection des liquides pour l'extraction du pétrole, à mesurage par résonance magnétique nucléaire**

Fluids are injected into porous strata for many purposes, for example, well stimulation, secondary-type oil recovery, mobility control, regulation of formation "wetness" and regulation of the encroachment of fluids. Fluids used for the above purposes are readily selected using nuclear magnetic resonance (NMR) measurements in the laboratory to measure the interaction between the fluids being injected into the reservoir rock and the in situ fluids or between injected fluids and the porous material. NMR measurements are taken for each component of sample fluids proposed to be injected in the reservoir for a desired purpose, or the sample fluid per se and each of the in situ fluids. NMR measurements are then taken of the interaction between the nuclei of sample fluids injected, the reservoir rock, and the nuclei of fluids in situ. Write: Marathon Oil Company, 539 South Main Street, Findlay, Ohio 45840, U.S.A.

Téléalimentation d'une ligne de transmission par câbles avec répéteurs soumise à l'influence de champs électriques externes**1,065,258/287****Remote Control Power Supply for Cable Transmission Line with Repeaters Submitted to External Electric Fields**

Téléalimentation d'une ligne de transmission par câbles avec répéteurs soumise à l'influence de champs électriques externes dans laquelle le courant alternatif de téléalimentation parcourt une boucle formée par deux paires de la ligne et où chaque répéteur est alimenté par le secondaire d'un transformateur de courant dont le primaire est formé de deux enroulements identiques en opposition intercalés en série l'un dans l'une des paires formant la boucle de téléalimentation et l'autre dans l'autre de ces paires. Elle s'applique avantageusement aux lignes de transmission ayant un parcours commun avec une ligne d'énergie électrique comme c'est le cas par exemple d'une ligne de transmission suivant une voie ferrée électrifiée. Écrire: Compagnie industrielle des Télécommunications Cit-Alcatel S.A., 12 rue de la Baume, 75008 Paris, France

Téléalimentation d'une ligne de transmission par câbles avec répéteurs soumise à l'influence de champs électriques externes**1,065,259/287****Remote Control Power Supply for Cable Transmission Line with Repeaters Submitted to External Electric Fields**

Téléalimentation d'une ligne de transmission par câbles avec répéteurs soumise à l'influence de champs électriques externes comportant, dans le circuit local d'alimentation de chaque répéteur intercalé entre deux tronçons de ligne, au moins un transformateur de courant ayant deux enroulements primaires identiques, l'un intercalé dans une première dérivation reliant le conducteur interne d'un tronçon de ligne au conducteur externe de l'autre tronçon de ligne, l'autre intercalé dans une deuxième dérivation reliant les autres conducteurs des tronçons de ligne. Elle s'applique à l'alimentation des répéteurs d'une ligne mono-coaxiale de transmission. Écrire: Compagnie industrielle des Télécommunications Cit-Alcatel S.A., 12 rue de la Baume, 75008 Paris, France

Locking Tab for Hook-in Type Shelving1,065,280/287
1,065,281/287**Tenon verrouillable pour rayonnages encliquetables**

An improved locking tab for horizontal components of hook-in type shelving, the locking tab being integral with the horizontal components and bent into the upper part of one of the slots of vertical shelf-supporting posts, this locking tab having in its preferred form an upper surface that is slanted backwards so that when the tab is moved to the locked position, this surface is perpendicular to the centerline of the post, thus preventing the locking tab from being bent back by shaking of the shelving; and a secondary tab with a shoulder surface abutting the post when the tab is bent into the locked position and a surface displaced from the post such that the end of a screwdriver can be placed between the latter surface and the post and twisted to bend the locking tab back into its original position, thus making it easy to disassemble the shelving. Write: Easy Up Shelving, Inc., 1700 First Avenue South, Seattle, Washington 98134, U.S.A.

Porous Carbonaceous Electrodes with Embedded Active Material

1,065,398/287

Électrodes carbonées poreuses, et matériau actif y noyé

Positive and negative electrodes are provided as rigid, porous carbonaceous matrices with particulate active material fixedly embedded. Active material such as metal chalcogenides, solid alloys of alkali metals or alkali earth metals along with other metals and their oxides in particulate form are blended with a thermosetting resin and a solid volatile to form a paste mixture. Various electrically conductive powders or current collector structures can be blended or embedded into the paste mixture which can be molded to the desired electrode shape. The molded paste is heated to a temperature at which the volatile transforms into vapor to impart porosity as the resin begins to cure into a rigid solid structure. Write: United States Department of Energy, Washington, D.C. 20545, U.S.A.

Method of Preparing a Negative Electrode Including Lithium Alloy for Use Within a Secondary Electrochemical Cell

1,065,399/287

Méthode de fabrication d'électrodes négatives comprenant un alliage de lithium pour cellule électrochimique secondaire

A negative electrode that includes a lithium alloy as active material is prepared by briefly submerging a porous, electrically conductive substrate within a melt of the alloy. Prior to solidification, excess melt can be removed by vibrating or otherwise manipulating the filled substrate to expose interstitial surfaces. Electrodes of such as solid lithium-aluminum filled within a substrate of metal foam are provided. Write: United States Department of Energy, Washington, D.C. 20545, U.S.A.

Soutirage en série d'énergie d'une ligne de transport HTCC

1,065,401/287

Power Series Tapping from a DCHV Transmission Line

Système pour le soutirage et la transformation en puissance complexe de l'énergie électrique d'une ligne de transport à haute tension continue (HTCC), le système étant relié en série avec cette ligne de transport. Le système comporte des extracteurs-convertisseurs de la haute tension continue en puissance active sous forme alternative ainsi qu'un ensemble générateur de puissance réactive relié à la ligne de transport et qui alimente à la fois les extracteurs-convertisseurs et la charge branchée sur la sortie du système. De plus, il est prévu un dispositif de commande du taux d'extraction et de conversion de l'énergie HTCC en fonction de la puissance active fournie par l'ensemble générateur. Ce dispositif de commande assure l'alimentation en puissance active par les seuls extracteurs-convertisseurs. À l'ensemble générateur est également associé un régulateur de tension qui a pour fonction de garder les tensions de sorties de cet ensemble générateur constantes, ce qui se traduit par une génération de puissance active nulle de la part de l'ensemble générateur. Le système de soutirage est soumis à une tension de valeur proportionnelle à l'énergie soutirée de la ligne de transport alors que l'enceinte métallique qui le contient est à la tension de la ligne HTCC. Écrire: Hydro-Québec, 75 ouest, boulevard Dorchester, Montréal (Québec) H2Z 1A4, Canada

Tête laser et application à un dispositif générateur laser

1,065,457/287

Laser Head and Application to a Laser Generator

L'invention concerne une tête laser et son application à un dispositif générateur laser. La tête laser comporte notamment un barreau de verre dopé au néodyme, une source d'excitation lumineuse et des lasers à rubis excités par cette source, les faisceaux émis par les lasers à rubis étant renvoyés vers une zone insuffisamment excitée du barreau de verre. Application à l'étude des plasmas. Écrire: Compagnie Générale d'Électricité S.A., 54 rue La Boétie, 75382 Paris Cedex 08, France

Dispositif générateur laser émettant à une longueur d'onde voisine de 1,3 micron **1,065,458/287** **Laser Emitting a Beam with Wavelength Around 1,3 Micron**

Dispositif générateur laser émettant à une longueur d'onde voisine de 1,3 micron comportant un oscillateur laser à verre dopé au néodyme, un amplificateur à gaz d'iode disposé à la sortie de l'oscillateur et des moyens pour que l'émission de l'oscillateur soit effectuée à une longueur d'onde voisine de 1,3 micron. Application à la production de plasmas. Écrire: Compagnie Générale d'Électricité S.A., 54 rue La Boétie, 75382 Paris Cedex 08, France

Tête laser **1,065,459/287** **Laser Head**

Tête laser comportant: — un barreau actif en verre dopé au néodyme, — une source lumineuse destinée à amplifier un faisceau laser de longueur d'onde 1,06 micron traversant le barreau, — au moins un cristal de rubis produisant un rayonnement dirigé sur le matériau actif, caractérisé par le fait que le cristal de rubis est disposé coaxialement au barreau à l'intérieur d'un réflecteur sphérique concave, le barreau et le cristal de rubis étant, à l'intérieur du réflecteur, disposés sensiblement de manière symétrique par rapport au centre du réflecteur sphérique. Écrire: Compagnie Générale d'Électricité, 54 rue La Boétie, 75382 Paris Cedex 08, France

Mechanisms to Heat Fluids to Higher Temperatures and Pressures **1,065,465/287** **Dispositif qui augmente la température et la pression des liquides**

The present invention relates to powerful sound impulse generation methods such as in use presently in the field of seismic exploration under water. Write: Peter Singfield, South Stukely, Quebec, JOE 2J0, Canada

Procédé de codage d'un signal et dispositif de transmission mettant en oeuvre le procédé **1,065,491/287** **Signal Coding Process and Transmitting Device Using the Process**

L'invention concerne le codage de signaux analogiques. On compare un signal analogique à un signal de comparaison croissant selon une loi donnée jusqu'à l'égalité avec le signal analogique; ensuite le signal de comparaison reste constant pendant un temps donné, et reprend sa valeur initiale, le dispositif de transmission comprend un circuit de traitement à l'émission et à la réception; à l'émission le circuit de traitement est précédé par un comparateur recevant le signal analogique et le signal de comparaison délivré par un convertisseur alimenté par le circuit de traitement; à la réception le signal à décoder est appliqué à un circuit de mise en forme relié à l'entrée du circuit de traitement. Écrire: Société Lannionnais d'Électronique Sle-Citerel S.A., Route de Perros Guirec, 22304 Lannion, France

Régulateur de niveau de type numérique **1,065,510/287** **Digital Type Level Regulator**

Régulateur de niveau pour système multiplex de fréquence, à amplificateur à gain variable commandé à partir d'une observation de l'amplitude d'une onde pilote présente dans le système multiplex, caractérisé en ce qu'il comporte un filtre numérique précédé d'un échantillonneur et d'un convertisseur analogique-numérique pour extraire l'onde pilote du système multiplex en aval du réseau à gain variable, un circuit de calcul relié au filtre numérique pour déterminer un nombre fonction du niveau de l'onde pilote en sortie du filtre, et un organe de comparaison numérique qui compare ce nombre à une valeur de référence en vue d'engendrer une commande dudit réseau. Dans une réalisation particulière le système multiplex est transposé vers les basses fréquences avant d'être traité numériquement. Écrire: Compagnie industrielle des Télécommunications Cit-Alcatel, 12 rue de la Baume, 75008 Paris, France

Paper or microfiche copies of U.S. Patent Applications may be obtained from NTIS, 5285 Port Royal Road, Springfield, Virginia 22161 at the prices indicated.

On peut obtenir des copies de demandes de brevets américains sur papier ou microfiche aux prix demandés en s'adressant au NTIS, 5285 Port Royal, Springfield (Virginia) 22161

Ambulator Drive Mechanism **PAT-APPL-6-007 285/WG/287** **Mécanisme d'entraînement pour plateformes mobiles**

A drive mechanism is provided particularly suitable for use in ambulators having a mobile platform that transports a paraplegic in a standing position, the unique drive mechanism enabling the platform to be of a minimum size with a very low center of gravity, and being movable about three axes to provide maximum maneuverability and access to confined spaces. Price: PC U.S. \$4.00/MF U.S. \$3.00. Write: U.S. Department of the Navy, Assistant Chief for Patents, The Office of Naval Research, Mailing Code: 302, Arlington, Virginia 22217. Please send a copy of your initial correspondence to: Canadian Consulate, 3 Parkway Building, Suite 1310, Philadelphia, Pennsylvania 19102.

**Antibacterial Textile Finishes Utilizing
Zinc Acetate and Hydrogen Peroxide**

PAT-APPL-974 171/WG/287

**Apprêts textiles antibactériens à base
d'acétate de zinc et de peroxyde
d'hydrogène**

The preparation of bacteriostatic, water-insoluble peroxide-containing complexes of zinc acetate, by reaction of zinc acetate with hydrogen peroxide in the presence of acetic acid, is disclosed. A process for in situ formation and deposition of these complexes on cellulosic and polyester textiles is described. The textile finishes so produced inhibit the growth and spreading of odor- and infection-producing gram-positive and gram-negative bacteria on the treated textiles. The antibacterial activity of the finished textiles is durable to repeated launderings. Price: PC U.S. \$4.50/MF U.S. \$3.00. Write: U.S. Department of Agriculture, Research Agreements and Patent Management Branch, General Services Division, Federal Building, Agricultural Research Service, Hyattsville, Maryland 20782 and send a copy of your initial correspondence to: Canadian Consulate, 3 Parkway Building, Suite 1310, Philadelphia, Pennsylvania 19102.

Automated Test Tube Stopper Remover

PAT-APPL-6-034 560/WG/287

**Appareil automatisé servant à enlever les
bouchons d'éprouvettes**

This invention relates to automatic closure-removing devices for receptacles, and more particularly to an apparatus for removing the stoppers from the tops of test tubes in a way to reduce the hazards from dangerous aerosols created when the stoppers are removed. Price: PC U.S. \$4.00/MF U.S. \$3.00. Write: U.S. Department of Health, Education and Welfare, National Institute of Health, Chief Patent Branch, Westwood Building, Bethesda, Maryland 20014 and send a copy of your initial correspondence to: Canadian Consulate, 3 Parkway Building, Suite 1310, Philadelphia, Pennsylvania 19102.

Automatic Spinning Strength Tester

PAT-APPL-6-034 881/WG/287

Appareil pour tester la force de filature

An apparatus for automatically testing the breaking strength of textiles during the spinning process is disclosed. A yarn clamping means affixed to a breaking assembly is rotatably mounted to an automatic timer which is pre-programmed to break yarn at set intervals. The spinning yarn is passed through a tension sensing device which measures the strength of the yarn at the breaking point, after the clamping means rotates, catches, and breaks the yarn. The clamping means then rotates back to the original position and restores and recombines the yarn as new feed yarn. Price: PC U.S. \$4.00/MF U.S. \$3.00. Write: U.S. Department of Agriculture, Research Agreements and Patent Management Branch, General Services Division, Federal Building, Agricultural Research Service, Hyattsville, Maryland 20782 and send a copy of your initial correspondence to: Canadian Consulate, 3 Parkway Building, Suite 1310, Philadelphia, Pennsylvania 19102.

**Carrier and Dispersal Mechanism for a
Microorganic Mosquito Larvicide**

PAT-APPL-6-030 961/WG/287

**Support et mécanisme de dispersion
pour un larvicide anti-maringouins
micro-organique**

A method of controlling mosquito larvae, by using a spore-forming bacillus ONR-60A obtained from screening clonal isolates from soil samples of known mosquito larval breeding sites. A larvicide comprising the bacillus and a carrier is formulated as a buoyant colloidal suspension which stabilizes just under the surface of the water to concentrate in the feeding zone of many varieties of mosquito larvae. Price: PC U.S. \$4.00/MF U.S. \$3.00. Write: U.S. Department of the Navy, Assistant Chief for Patents, The Office of Naval Research, Mailing Code: 302, Arlington, Virginia 22217 and send a copy of your initial correspondence to: Canadian Consulate, 3 Parkway Building, Suite 1310, Philadelphia, Pennsylvania 19102.

Catalyst for Synthesis of Methanol

PAT-APPL-964 860/WG/287

Catalyseur de synthèse du méthanol

A catalyst for synthesis of methanol is prepared from an alloy of copper with a metal from the rare earth or actinide series or group IVB of the periodic table. The alloy is reacted with a gas having sufficient oxidizing power to oxidize the rare earth, actinide or group IVB metal. Price: PC U.S. \$4.00/MF U.S. \$3.00. Write: U.S. Department of the Interior, Branch of Patents, 18th and C Streets, N.W., Washington, D.C. 20240 and send a copy of your initial correspondence to: Canadian Consulate, 3 Parkway Building, Suite 1310, Philadelphia, Pennsylvania 19102.

Channel Sealant Compositions**PAT-APPL-6-026 866/WG/287****Compositions d'un produit de scellement de couloirs**

A sealant composition is described comprising a non-crosslinked, elastomeric mastic and an extrusion-inhibiting amount of vulcanized rubber particles of irregular shape and having sharp edges and angular surfaces. When the composition is used as a channel sealant, the ability of the particles to deform at structural gaps while offering resistance to extrusion prevents the loss of the elastomeric mastic. Price: PC U.S. \$4.00/MF U.S. \$3.00. Write: U.S. Department of the Air Force, AF/JACP, Washington, D.C. 20314 and send a copy of your initial correspondence to: Canadian Consulate, 3 Parkway Building, Suite 1310, Philadelphia, Pennsylvania 19102.

Connector-to-Connector Adapter**PAT-APPL-6-026 982/WG/287****Adapteur pour connecteurs**

The invention provides a connector-to-connector adapter which permits the adaptation from one connector interface to another connector interface without modification of electrical equipment interfaces. An adaptor shell has a plurality of contact shafts which replace the respective contacts of the dissimilar connectors to be joined. The adaptor shell is joined to one connector and the contact shafts are inserted first into the openings of one connector and then the other connector. Finally the adaptor shell is joined to the other connector. A pin is integrally connected to one end of the contact shaft and a socket contact with retention means is integrally connected to the other end. Price: PC U.S. \$4.00/MF U.S. \$3.00. Write: U.S. Department of the Navy, Assistant Chief for Patents, The Office of Naval Research, Mailing Code: 302, Arlington, Virginia 22217 and send a copy of your initial correspondence to: Canadian Consulate, 3 Parkway Building, Suite 1310, Philadelphia, Pennsylvania 19102.

Cooling Arrangement for Plug-in Module Assembly**PAT-APPL-6-007 524/WG/287****Dispositif de refroidissement pour modules enfichables**

The improved cooling arrangement for an electronic plug in module assembly has a plurality of modules supported in grooves in a pair of parallel sides. Each parallel side is provided with fluid passageways for carrying a cooling liquid for removing heat transferred from a heat sink on each module to the sides. A plurality of apertures are provided in each side between adjacent grooves and carry fins through which cool air is blown to cool each side of each plug-in module. Price: PC U.S. \$4.00/MF U.S. \$3.00. Write: U.S. Department of the Navy, Assistant Chief for Patents, The Office of Naval Research, Mailing Code: 302, Arlington, Virginia 22217. Please send a copy of your initial correspondence to: Canadian Consulate, 3 Parkway Building, Suite 1310, Philadelphia, Pennsylvania 19102.

Cross-linked Starch Halohydrins and Their Nitrogen-Containing Substitution Products**PAT-APPL-6-032 850/WG/287****Halohydrines de féculles réticulées et leurs produits de substitution contenant de l'azote**

Crosslinked starch is reacted with an epihalohydrin in the presence of a strong acid catalyst to produce the 3-halo-2-hydroxypropyl ether. Substitution of the halogen with nitrogen-containing compounds enables the preparation of novel water-insoluble cationic, anionic, and chelating starch ethers, as well as starch ethers having degrees of substitution heretofore unattainable in the prior art. Price: PC U.S. \$4.00/MF U.S. \$3.00. Write: U.S. Department of Agriculture, Research Agreements and Patent Management Branch, General Services Division, Federal Building, Agricultural Research Service, Hyattsville, Maryland 20782 and send a copy of your initial correspondence to: Canadian Consulate, 3 Parkway Building, Suite 1310, Philadelphia, Pennsylvania 19102.

Ejected Roller Shaft Disconnect Mechanism**PAT-APPL-944 433/WG/287****Mécanisme de débranchement fonctionnant par éjection des rouleaux de l'arbre de transmission**

The rotary power transmitting shaft decoupling device has a driving element disposed coaxially within a driven element and keyed thereto by a plurality of rollers held in aligned grooves and slots of the driving and driven elements, respectively, by an indexing ring that is coaxial with and surrounds the driven element. Actuation to effect decoupling is effected by arresting rotation of the indexing ring until the rollers become aligned with slots in the ring through which the rollers are ejected. Price: PC U.S. \$4.00/MF U.S. \$3.00. Write: U.S. Department of the Navy, Assistant Chief for Patents, The Office of Naval Research, Mailing Code: 302, Arlington, Virginia 22217 and send a copy of your initial correspondence to: Canadian Consulate, 3 Parkway Building, Suite 1310, Philadelphia, Pennsylvania 19102.

Electric Wind Generator**PAT-APPL-974 154/WG/287****Éolienne électrique**

A device for generating an air jet without the use of moving parts is provided. High voltage is used to create a corona discharge electric wind in a ducted, compact, portable generator that can be used for augmentation cooling applications where high voltage is available. Price: PC U.S. \$4.00/MF U.S. \$3.00. Write: U.S. Department of the Navy, Assistant Chief for Patents, The Office of Naval Research, Mailing Code: 302, Arlington, Virginia 22217. Please send a copy of your initial correspondence to: Canadian Consulate, 3 Parkway Building, Suite 1310, Philadelphia, Pennsylvania 19102.

Electrical Cable Coupler with Rotatable Protective Covers**PAT-APPL-6-006 138/WG/287****Coupleur de câbles électriques avec enveloppe protectrice tournante**

The invention relates to an electrical cable coupler provided with a protective cover arrangement to protect the coupler contacts against contamination by dust and moisture and, more particularly, to an improved electrical cable coupler wherein plug and socket members are each provided with a rotatable protective cover which normally covers its electrical contacts when the plug and socket are uncoupled and which rotates to expose the contacts for electrical engagement when the plug and socket members. Price: PC U.S. \$4.00/MF U.S. \$3.00. Write: U.S. Department of the Interior, Branch of Patents, 18th and C Streets, N.W., Washington, D.C. 20240 and send a copy of your initial correspondence to: Canadian Consulate, 3 Parkway Building, Suite 1310, Philadelphia, Pennsylvania 19102.

Flow-Closing Bleed Valve Assembly**PAT-APPL-6-029 584/WG/287****Vanne de décharge comportant un mécanisme d'arrêt du flux**

This inventive flow-closing bleed valve assembly is intended for use in starting a turbofan engine having a compressor section with: a fore-to-aft air flow therein; deteriorated clearances; and aft portion, and overboard duct outlets. Accordingly, the principal object of this invention is to provide a flow-closing bleed valve assembly to start such an aforementioned turbofan engine, by teaching the structure of a preferred embodiment thereof. Price: PC U.S. \$4.00/MF U.S. \$3.00. Write: U.S. Department of the Air Force, AF/JACP, Washington, D.C. 20314 and send a copy of your initial correspondence to: Canadian Consulate, 3 Parkway Building, Suite 1310, Philadelphia, Pennsylvania 19102.

Fluorinated Phthalonitriles and Polyphthalocyanines Therefrom**PAT-APPL-6-026 863/WG/287****Phthalonitriles fluorés et polyphthalocyanines dérivés**

The invention pertains generally to fluorinated tetranitriles and high-temperature resins prepared therefrom, and, in particular, to perfluorinated phthalonitriles and polyphthalocyanine resins. Polyphthalocyanine resins compare favorably with epoxies as structural materials with the added advantage of a higher thermal stability. These resins are stable to about 235°C in an oxidizing atmosphere. One important property of resins which both epoxies and polyphthalocyanines are lacking to an objectionable degree for some applications is water repellency. Both resins absorb H₂O in an amount from about five to ten percent of their weight in water. Price: PC U.S. \$4.00/MF U.S. \$3.00. Write: U.S. Department of the Navy, Assistant Chief for Patents, The Office of Naval Research, Mailing Code: 302, Arlington, Virginia 22217 and send a copy of your initial correspondence to: Canadian Consulate, 3 Parkway Building, Suite 1310, Philadelphia, Pennsylvania 19102.

Improvement in Process for Backwashing Reverse Osmosis and Ultrafiltration Membranes**PAT-APPL-6-014 173/WG/287****Procédé amélioré de nettoyage des membranes d'osmose inverse et d'ultrafiltration**

Improved efficiency of backwashing of reverse osmosis and ultrafiltration membranes is achieved by use of a membrane support material designed to provide high fluid flow rate parallel to the membrane. The support material comprises a combination of a fabric and a spacer material. Price: PC U.S. \$4.00/MF U.S. \$3.00. Write: U.S. Department of the Interior, Branch of Patents, 18th and C Streets, N.W., Washington, D.C. 20240 and send a copy of your initial correspondence to: Canadian Consulate, 3 Parkway Building, Suite 1310, Philadelphia, Pennsylvania 19102.

Insect Repellents**PAT-APPL-6-008 814/WG/287****Insectifuges**

This invention relates to insect repellents and, more particularly, to certain novel carboxamides containing an alicyclic moiety and their use as insect repellents. Price: PC U.S. \$4.50/MF U.S. \$3.00. Write: U.S. Department of Agriculture, Research Agreements and Patent Management Branch, General Services Division, Federal Building, Agricultural Research Service, Hyattsville, Maryland 20782 and send a copy of your initial correspondence to: Canadian Consulate, 3 Parkway Building, Suite 1310, Philadelphia, Pennsylvania 19102.

Interferometer**PAT-APPL-6-037 560/WG/287****Interféromètre**

A high resolution interferometer is provided which is insensitive to slight misalignment of its elements, avoids channeling in the spectrum, generates a maximum equal path fringe contrast, produces an even two-sided interferogram without critical matching of the wedge angles of the beamsplitter and compensator wedges, and is optically phase tunable. The interferometer includes a mirror along the path of each beam component produced by the beamsplitter, for reflecting the beam component from the beamsplitter to a corresponding retroreflector and for reflecting the beam returned by the retroreflector back to the beamsplitter. The fact that the mirror 'covers' the retroreflector, so that the mirror reflects the beam component before and after it reaches the retroreflector, results in the system being insensitive to slight tilting of the mirror. Price: PC U.S. \$4.00/MF U.S. \$3.00. Write: Patent Counsel, NASA Resident Legal Office, Mail Code: 180-601, 4800 Oak Grove Drive, Pasadena, California 91103 and send a copy of your initial correspondence to: Canadian Consulate General, 510 West Sixth Street, Los Angeles, California 90014.

Iodinatable Bile Salts**PAT-APPL-805 960/WG/287****Sels biliaires iodables**

Iodinatable bile salt derivatives are obtained by providing bile salts and their glycine and taurine conjugates with iodinated groups. The radioiodinated compounds are useful in the radioimmunoassay of bile salts and in physiological studies. The preferred compound is cholyglycylhistamine. The synthesis of radioiodinated conjugates and their purification by extraction and silica gel chromatography are described. Price: PC U.S. \$4.50/MF U.S. \$3.00. Write: U.S. Department of Health, Education and Welfare, National Institute of Health, Chief Patent Branch, Westwood Building, Bethesda, Maryland 20014 and send a copy of your initial correspondence to: Canadian Consulate, 3 Parkway Building, Suite 1310, Philadelphia, Pennsylvania 19102.

Method of Bonding Particle Board and the Like Using Polyisocyanate/Phenolic Adhesive**PAT-APPL-970 944/WG/287****Méthode de liage des panneaux de particules et autres articles du genre à l'aide de polyisocyanate ou d'adhésifs phénoliques**

A method of forming particle board is characterized by the use of an adhesive comprising a polyisocyanate and a phenolic adhesive. Enhanced adhesive characteristics and other advantages are associated with the method in which the polyisocyanate is added to the wood particles, etc. prior to application of the phenolic adhesive. Price: PC U.S. \$4.00/MF U.S. \$3.00. Write: U.S. Department of Agriculture, Research Agreements and Patent Management Branch, General Services Division, Federal Building, Agricultural Research Service, Hyattsville, Maryland 20782 and send a copy of your initial correspondence to: Canadian Consulate, 3 Parkway Building, Suite 1310, Philadelphia, Pennsylvania 19102.

Method for Isolating a Spore-Forming Mosquito Larvicide**PAT-APPL-6-031 277/WG/287****Méthode d'isolation d'un larvicide anti-maringouins formant des spores**

A method of controlling mosquito larvae, by using a spore-forming bacillus ONR-60A obtained from screening clonal isolates from soil samples of known mosquito larval breeding sites. A larvicide comprising the bacillus and a carrier is formulated as a buoyant colloidal suspension which stabilizes just under the surface of the water to concentrate in the feeding zone of many varieties of mosquito larvae. Price: PC U.S. \$4.00/MF U.S. \$3.00. Write: U.S. Department of the Navy, Assistant Chief for Patents, The Office of Naval Research, Mailing Code: 302, Arlington, Virginia 22217 and send a copy of your initial correspondence to: Canadian Consulate, 3 Parkway Building, Suite 1310, Philadelphia, Pennsylvania 19102.

Method for Separating Biological Cells**PAT-APPL-6-017 888/WG/287****Procédé de séparation des cellules**

A method for separating biological cells by suspending a mixed cell population in a body of aqueous polymer is described. The system consists of phases for which these cells exhibit an affinity including at least one droplet phase with a surface potential and one droplet phase characterized by another surface potential. The system is subjected to an electrostatic field established between a pair of electrodes with the field being of sufficient intensity for causing some of the droplets to migrate toward one of the electrodes with an attendant separation of the cells. Price: PC U.S. \$4.00/MF U.S. \$3.00. Write: Marshall Space Flight Center, Mail Code: CC01, Huntsville, Alabama 35812 and send a copy of your initial correspondence to: Canadian Consulate General, 900 Coastal States Building, 260 Peachtree Street, Atlanta, Georgia 30303.

Molten Metal-Liquid Explosive Device**PAT-APPL-6-028 478/WG/287****Explosif liquide à base de métal fondu**

The patent application describes an explosive device comprising (1) a metal liner composed of a metal selected from the group consisting of aluminum, magnesium, copper, and brass, the liner enclosing a chamber; (2) a liquid contain in the chamber; (3) a layer of pyrotechnic material surrounding the outside of the liner. The pyrotechnic material is composed of a mixture of

powders of (a) nickel; (b) metal oxide; and (c) an aluminum containing component which may be (i) aluminum or (ii) a mixture of from 50 to less than 100 weight percent of aluminum and from more than zero to 50 weight percent of a metal which can be magnesium, zirconium, bismuth, beryllium, boron, tantalum, copper, silver, niobium, or mixtures thereof; and (4) means for igniting the pyrotechnic material. This device is useful as an explosive, particularly as an underwater explosive. Price: PC U.S. \$4.00/MF U.S. \$3.00. Write: U.S. Department of the Navy, Assistant Chief for Patents, The Office of Naval Research, Mailing Code: 302, Arlington, Virginia 22217. Please send a copy of your initial correspondence to: Canadian Consulate, 3 Parkway Building, Suite 1310, Philadelphia, Pennsylvania 19102.

**Novel Inlet System for Direct Gas
Chromatographic and Combined Gas
Chromatographic/Mass Spectrometric
Analysis of Food Volatiles**

PAT-APPL-6-015 507/WG/287

**Appareil d'analyse des éléments alimentaires
volatiles par chromatographie directe et
combinée au gaz et par spectométrie de
masse**

An apparatus for analyzing volatile components from raw or processed food products using either direct gas chromatography or combined direct gas chromatography and mass spectrometry is disclosed. An inlet assembly containing a sample is appropriately affixed to a means of supplying helium carrier gas. Volatiles are driven off the sample and fed to a condenser assembly where the moisture is removed. The resultant moisture free volatiles are fed to a gas chromatograph or combined direct gas chromatograph and mass spectrograph for analysis. Price: PC U.S. \$4.00/MF U.S. \$3.00. Write: U.S. Department of Agriculture, Research Agreements and Patent Management Branch, General Services Division, Federal Building, Agricultural Research Service, Hyattsville, Maryland 20782 and send a copy of your initial correspondence to: Canadian Consulate, 3 Parkway Building, Suite 1310, Philadelphia, Pennsylvania 19102.

**Pressure Differential Seafloor
Corer-Carrier**

PAT-APPL-6-034 220/WG/287

**Appareil de carottage et de transport pour
travaux sur lit marin appliquant un différen-
tiel de pression**

A pressure differential seafloor corer-carrier is described for obtaining long core samples of seafloor sediments. The corer-carrier is composed of two main components: The first component is a pump assembly that pumps seawater and sediment as to create a negative pressure differential; the negative pressure differential being the driving force that forces the corers into the seafloor such that cores of over 100 feet in length can be obtained. The second component is a space frame mounted and fastened to the pump and functions as a rack to which conventional corers are attached. Once the corers are embedded to their full length, the pump is used to create a positive pressure differential which helps remove the corer-carrier from the seafloor. Price: PC U.S. \$4.00/MF U.S. \$3.00. Write: U.S. Department of the Navy, Assistant Chief for Patents, The Office of Naval Research, Mailing Code: 302, Arlington, Virginia 22217 and send a copy of your initial correspondence to: Canadian Consulate, 3 Parkway Building, Suite 1310, Philadelphia, Pennsylvania 19102.

**Process for Improving Baking Properties
of Unbleached Flour**

PAT-APPL-6-004 785/WG/287

**Méthode d'amélioration des propriétés
boulangères de la farine éeue**

Unbleached cake flour is heated at a temperature of 49-93C for 1 hour to ten weeks to improve its baking properties Starch is subjected to controlled swelling by heating in the presence of excess moisture at a temperature of 54-71C. Either treated material or mixtures of both may be substituted for unbleached flour in high-sugar baked good mixes to obtain improved baking properties such as texture, grain, volume, and eating quality. Unbleached bread flour is simultaneously ground and heated and then subjected to three air-classification steps to obtain a flour suitable for use in high-sugar baked goods. Price: PC U.S. \$4.00/MF U.S. \$3.00. Write: U.S. Department of Agriculture, Research Agreements and Patent Management Branch, General Services Division, Federal Building, Agricultural Research Service, Hyattsville, Maryland 20782 and send a copy of your initial correspondence to: Canadian Consulate, 3 Parkway Building, Suite 1310, Philadelphia, Pennsylvania 19102.

**Process for the Preparation of Cellulose
Ether Derivatives**

PAT-APPL-6-024 551/WG/287

**Méthode de préparation de dérivés d'éther
de cellulose**

It was discovered that the process for the preparation of cellulose ether derivatives from a never-dried, nonpurified natural polysaccharide, can be improved by minimizing the step of dispersing the material in a suitable reaction medium before converting the material to an alkali cellulose. This can be accomplished by fluidizing the raw feed material during the contacting of that material with caustic and etherifying reagents. One aspect of the invention is that it may be used as a sole process unit or it may be integrated into the processing scheme of wood processing plant (pulpmill) in order to more efficiently handle waste materials. Price: PC U.S. \$4.00/MF U.S. \$3.00. Write: U.S. Department of Agriculture, Research Agreements and Patent Management Branch, General Services Division, Federal Building, Agricultural Research Service, Hyattsville, Maryland 20782 and send a copy of your initial correspondence to: Canadian Consulate, 3 Parkway Building, Suite 1310, Philadelphia, Pennsylvania 19102.

**Process for Producing a Powdered
Flavoring Material**

PAT-APPL-6-017 001/WG/287

**Méthode de fabrication d'une poudre
aromatisée**

A powdered orange flavor containing 27 fold orange oil adsorbed on rice starch was prepared by a methanol treatment process. The powder contained the equivalent flavoring potency of 18% by wt. of whole orange oil, which was the maximum obtainable; other rice starch samples contained lesser amounts and had lower folds. Two other edible polymers, egg albumin and Mor-rex (hydrolyzed cereal solids), also had some capacity, when treated with methanol, for polar orange oil components. These were less suitable than starch, however, because of inadequate concentration on the polymer, a low degree of folding, or distorted oil compositions. Price: PC U.S. \$4.00/MF U.S. \$3.00. Write: U.S. Department of Agriculture, Research Agreements and Patent Management Branch, General Services Division, Federal Building, Agricultural Research Service, Hyattsville, Maryland 20782 and send a copy of your initial correspondence to: Canadian Consulate, 3 Parkway Building, Suite 1310, Philadelphia, Pennsylvania 19102.

**Quarternary Ureidomethyl
Phosphonium Salts**

PAT-APPL-6-027 696/WG/287

**Sels quaternaires de phosphonium
d'uréidométhyle**

Novel quaternary ureidomethyl phosphonium salts are prepared by condensing a urea having the formula RNHC(O)NR (R double prime) with a quarternary hydroxymethyl phosphonium salt having the formula (HOCH₂)₄P (+)X(-) in a molar ratio of at least 2.1. The products, which are characterized by the absence of residual hydroxymethyl groups, are useful as finishing agents for imparting flame retardant properties to cotton fabrics. Price: PC U.S. \$4.50/MF U.S. \$3.00. Write: U.S. Department of Agriculture, Research Agreements and Patent Management Branch, General Services Division, Federal Building, Agricultural Research Service, Hyattsville, Maryland 20782 and send a copy of your initial correspondence to: Canadian Consulate, 3 Parkway Building, Suite 1310, Philadelphia, Pennsylvania 19102.

**Radiation Transmissive Housing
Having a Heated Load Bearing
Gasket**

PAT-APPL-6-013 719/WG/287

**Appareil d'entreposage du matériel
transmettant des radiations muni d'un
joint chauffé à palier porteur**

Apparatus for protectively housing radiation transmitting or receiving equipment is provided with a window in the form of a spherical segment, which is formed of material transmissive to radiation of the frequencies of the equipment, and which has a seating surface. A mounting for providing forces to support the window and to resist external pressure applied thereto has a bearing surface, and a heated bearing gasket abutts both the bearing and seating surfaces. The gasket is provided for resisting wear between the bearing and seating surfaces, and also for transferring selected amounts of heat to the window. A heat regulator is coupled between the window and the gasket to control the amount of heat transferred to the window by the gasket, and structure is provided for continuously joining the window, the mounting and the gasket. Price: PC U.S. \$4.00/MF U.S. \$3.00. Write: U.S. Department of the Navy, Assistant Chief for Patents, The Office of Naval Research, Mailing Code: 302, Arlington, Virginia 22217. Please send a copy of your initial correspondence to: Canadian Consulate, 3 Parkway Building, Suite 1310, Philadelphia, Pennsylvania 19102.

**Recovery of Gallium from Acid
Process Solution**

PAT-APPL-6-008 298/WG/287

**Récupération du gallium à partir d'une
solution acide**

The present invention relates to a method of recovering gallium from a mineral source. More particularly, the present invention relates to a method of selectively recovering gallium values from a mineral source containing iron and aluminum. Gallium compounds are valuable materials because gallium finds extensive use in the preparation of light emitting diodes and other semiconductor, devices which are widely used in the electronics and other industries. Price: PC U.S. \$4.00/MF U.S. \$3.00. Write: U.S. Department of the Interior Branch of Patents, 18th and C Streets, N.W., Washington, D.C. 20240 and send a copy of your initial correspondence to: Canadian Consulate 3 Parkway Building, Suite 1310, Philadelphia, Pennsylvania 19102.

**Recovery of Metals from Atlantic Sea
Nodules**

PAT-APPL-6-027 135/WG/287

**Récupération de métaux à partir de
nodules de l'océan Atlantique**

Nickel, cobalt and manganese are selectively recovered from Atlantic deep sea nodules by means of a preliminary treatment with acetic acid followed by leaching with sulfurous acid. Price: PC U.S. \$4.00/MF U.S. \$3.00. Write: U.S. Department of the Interior, Branch of Patents, 18th and C Streets, N.W., Washington, D.C. 20240 and send a copy of your initial correspondence to: Canadian Consulate, 3 Parkway Building, Suite 1310, Philadelphia, Pennsylvania 19102.

Sorption of Tungsten from Alkaline Solutions

PAT-APPL-6-027 134/WG/287

Sorption de tungstène à partir de solutions alcalines

According to the present invention, ion exchange resin beads essentially spherical in form and having a diameter of about 300-850 microns may be prepared by copolymerization of 8-hydroxyquinoline resorcinol and formaldehyde in suspension in a suitable organic medium in the presence of a dispersant. The resulting beads are more porous and have a higher ion exchange capacity than resin powders or granules prepared by conventional means such as crushing and screening bulk polymerized resin. In addition the beads of the invention offer less resistance to the flow of solution through an ion exchange column. Price: PC U.S. \$4.00/MF U.S. \$3.00. Write: U.S. Department of the Interior, Branch of Patents, 18th and C Streets, N.W., Washington, D.C. 20240 and send a copy of your initial correspondence to: Canadian Consulate, 3 Parkway Building, Suite 1310, Philadelphia, Pennsylvania 19102.

Stacked SQUID Arrays

PAT-APPL-6-022 764/WG/287

Dispositif SQUID

The described invention is briefly summarized as a means for increasing the sensitivity of Josephson Junction Cryogenic Magnetometers by unique design and construction of DC SQUID arrays. The SQUIDS are arrayed vertically and the sensitivity of each sensing point is increased by making an intimate, co-axial superposition of two or more two-junction SQUID loops using, for example, evaporated thin-film technology although fabrication is not limited solely to this technique. The device permits multiple SQUID loops to enclose the same applied magnetic flux thereby increasing the sensing volume and improving the coupling to the applied magnetic field. A primary object of invention is to provide a magnetometer of greatly reduced size, greatly increased sensitivity, and the capability to measure higher-order derivatives of magnetic fields. A further object of invention is to provide a magnetic sensing device employing a plurality of DC SQUID loops, each enclosing the same magnetic flux and a method for producing such a device. Price: PC U.S. \$4.00/MF U.S. \$3.00. Write: U.S. Department of the Navy, Assistant Chief for Patents, The Office of Naval Research, Mailing Code: 302, Arlington, Virginia 22217 and send a copy of your initial correspondence to: Canadian Consulate, 3 Parkway Building, Suite 1310, Philadelphia, Pennsylvania 19102.

Surface Elevation Measuring Apparatus

PAT-APPL-6-039 241/WG/287

Appareil de mesure des élévations de surfaces

A terrain probe is described for sensing the elevation of a terrain surface whose profile is being measured and followed. A two-phase induction motor will raise or lower the terrain probe in response to either an increase or decrease in the elevation of the terrain surface. A four arm bridge circuit, which has an arm enclosed within the terrain probe, in combination with a low frequency oscillator, a differential amplifier, and power amplifier, generate a sinusoidal drive signal which controls the two-phase induction motor. Price: PC U.S. \$4.00/MF U.S. \$3.00. Write: U.S. Department of the Navy, Assistant Chief for Patents, The Office of Naval Research, Mailing Code: 302, Arlington, Virginia 22217 and send a copy of your initial correspondence to: Canadian Consulate, 3 Parkway Building, Suite 1310, Philadelphia, Pennsylvania 19102.

Thermally Stable Aromatic Enyne Polyimides

PAT-APPL-6-032 809/WG/287

Polyimides enynes aromatiques thermostables

High molecular weight aromatic enyne polyimide thermoplastics are prepared by reacting an aromatic dianhydride with (E)-3,3' - (1-buten-3-ynylene) dianiline alone or in admixture with an aromatic diamine. Because of the presence of the enyne moiety in the polymer backbone, the polymers can be lightly crosslinked to provide solvent-resistant thermoplastics. The polymers are particularly useful in fabricating graphite-reinforced, thermoplastic composites for structural applications. Price: PC U.S. \$4.00/MF U.S. \$3.00. Write: U.S. Department of the Air Force, AF/JACP, Washington, D.C. 20314 and send a copy of your initial correspondence to: Canadian Consulate, 3 Parkway Building, Suite 1310, Philadelphia, Pennsylvania 19102.

Thermoclamps

PAT-APPL-6-017 623/WG/287

Serre-joints thermiques

This patent application covers an apparatus for heat flattening and/or forming titanium sheet material under heat and pressure using thermoclamps fabricated of materials having different thermal expansion properties. Upper and lower dies are made of one alloy having a large thermal expansion while tie bars between the two dies are made of an alloy having low thermal expansion. During heat cycles the difference in expansion causes the tie bars to close the gap between the dies and apply pressure to the titanium sheet between in an alternate arrangement, the thermal clamping action coins a bead into a diaphragm to make a vacuum tight seal so that the atmospheric pressure in the oven produces the forming or flattening of the sheet. Price: PC U.S. \$4.00/MF U.S. \$3.00. Write: U.S. Department of the Air Force, AF/JACP, Washington, D.C. 20314 and send a copy of your initial correspondence to: Canadian Consulate, 3 Parkway Building, Suite 1310, Philadelphia, Pennsylvania 19102.

Ultra-Black Coating Due to Surface Morphology

PAT-APPL-6-031 706/WG/287

Revêtement ultra-noir attribuable à la structure de la surface

The invention provides a method of producing an ultra-black surface coating, having an extremely high light absorption capacity, on a substrate, such as a metal, ceramic, glass, or plastic, the blackness being associated with a unique surface morphology consisting of a dense array of microscopic pores etched into the surface, as well as the resulting coated substrate. The ultra-black surface, which has a spectral reflectance on the order of about from 0.5 to 1.0% at wavelengths of light of about from 320 to 2140 nanometers, finds use as a solar collector in the field of solar energy. Price: PC U.S. \$4.00/MF U.S. \$3.00. Write: U.S. Department of Commerce, National Technical Information Service, 5285 Port Royal Road, Springfield, Virginia 22161 and send a copy of your initial correspondence to: Canadian Consulate, 3 Parkway Building, Suite 1310, Philadelphia, Pennsylvania 19102.

Ultrasonic Wire-Bonding Apparatus for Negating Torsional Forces Present in a Transversely-Driven Wire-Bonding Tool

PAT-APPL-6-015 571/WG/287

Dispositif de fils d'assemblage supersonique servant à annuler les forces de torsion provoquées par des outils d'assemblage de fils actionnés transversalement

Ultrasonic bonding is used to electrically couple terminal and other wires to an active semiconductor chip. Conventionally, a magnetostrictive transducer having a longitudinal driving mode causes a bonding tool to vibrate while holding the wire in intimate contact with the chip. However, bond quality has not been consistently good due primarily to certain torsional moments of forces present in the longitudinal driving mode. This problem can be avoided by modifying the conventional manner in which the bonding tool is coupled to the transducer. Specifically, the tool and its clamping surfaces are specially-shaped to provide a Vee-block clamping arrangement in which the tool is held in a symmetric two-point line contact with the clamping pressure being supplied by a set-screw engaging the tool midway of the two points. Price: PC U.S. \$4.00/MF U.S. \$3.00. Write: U.S. Department of the Navy, Assistant Chief for Patents, The Office of Naval Research, Mailing Code: 302, Arlington, Virginia 22217. Please send a copy of your initial correspondence to: Canadian Consulate, 3 Parkway Building, Suite 1310, Philadelphia, Pennsylvania 19102.

Rotary Shaft Decoupling Mechanism

PAT-APPL-952 169/WG/287

Mécanisme découpleur à arbre rotatif

The rotary power transmitting shaft decoupling device has a driving component axially aligned with a driven component and keyed thereto by a plurality of force transmitting elements held in operable relation to the driving and driven components, respectively, by an axially shiftable slide element that is coaxial with the driving and driven components and is provided with a lead screw. Actuation to effect decoupling is effected by engaging the lead screw with a plunger so that rotation of the device results in axial shifting of the slide element and withdrawal of the force transmitting elements from operable relation to the driving and driven components. Price: PC U.S. \$4.00/MF U.S. \$3.00. Write: U.S. Department of the Navy, Assistant Chief for Patents, The Office of Naval Research, Mailing Code: 302, Arlington, Virginia 22217 and send a copy of your initial correspondence to: Canadian Consulate, 3 Parkway Building, Suite 1310, Philadelphia, Pennsylvania 19102.

Sex Attractant for Tobacco Moths

PAT-APPL-6-025 135/WG/287

Attractif de la pyrale du tabac

This invention relates to insect attractants and more specifically to a highly effective attractant for the tobacco budworm. Price: PC U.S. \$4.00/MF U.S. \$3.00. Write: U.S. Department of Agriculture, Research Agreements and Patent Management Branch, General Services Division, Federal Building, Agricultural Research Service, Hyattsville, Maryland 20782 and send a copy of your initial correspondence to: Canadian Consulate, 3 Parkway Building, Suite 1310, Philadelphia, Pennsylvania 19102.

Shaft Decoupling Device

PAT-APPL-931 348/WG/287

Mécanisme découpleur à arbre

A shaft decoupler is described wherein driving and driven components having grooved flanges are keyed together by rollers held in the grooves by lands between recesses of a retaining assembly that normally rotates with the mentioned components and is momentarily arrested to allow the driving and driven components to advance the roller carrying grooves to alignment with the recesses to effect decoupling. The decoupler is characterized by the use of high strength plastic rollers, cooperating indexing elements to limit relative rotation between the driving component and the retaining assembly, and a solid lubricant filled plastic thrust and journal bearing. Price: PC U.S. \$4.00/MF U.S. \$3.00. Write: U.S. Department of the Navy, Assistant Chief for Patents, The Office of Naval Research, Mailing Code: 302, Arlington, Virginia 22217 and send a copy of your initial correspondence to: Canadian Consulate, 3 Parkway Building, Suite 1310, Philadelphia, Pennsylvania 19102.

An improved energy storage superheater assembly is described for storing heat energy resulting from solar or other types of energy. An enclosed housing includes a heat transfer means in the bottom or top which is heated by $SO_2 + O_2$ due to solar-chemical reaction or any other suitable means. The heat transfer means heats wet steam in a superheater-piping that passes through the heat transfer means to produce superheated steam. A plurality of vertical, potassium-containing steel wall heat pipes extends from the heat transfer means and distributes heat over the large area of the housing. Vertical containers which contain a salt are assembled among the vertical pipes and are heated by the heat radiated and convected from the vertical pipes in order to store heat in the salt-containers by 'heat of fusion'. During heat withdrawals, heat is radiated and convected from the salt-containers to the vertical steel pipes. Heat is carried to the heat transfer means by the steel pipes which in turn heats the superheater tubes. Price: PC U.S. \$4.00/MF U.S. \$3.00. Write: U.S. Department of the Navy, Assistant Chief for Patents, The Office of Naval Research, Mailing Code: 302, Arlington, Virginia 22217. Please send a copy of your initial correspondence to: Canadian Consulate, 3 Parkway Building, Suite 1310, Philadelphia, Pennsylvania 19102.

CANADA COMMERCE

The Department of Industry, Trade and Commerce publishes Canada Commerce in English and French six times a year as well as a monthly Canada Commerce Newsletter. Beginning with the November issue of the Canada Commerce Newsletter, a regular feature will include information on selected multilateral and new projects abroad which have been approved by world banks and the United Nations Development Program (UNDP). Canadian firms interested in considering these tenders may request to be added to the mailing list to receive Canada Commerce regularly. Write: The Editor, Canada Commerce, Public Information Branch (98), Department of Industry, Trade and Commerce, Ottawa, Ontario K1A 0H5

CANADA COURIER

Published twenty-two times a year: 5 English International, 5 United States, 3 French, 3 German, 2 Japanese and 4 Spanish issues by the Department of Industry, Trade and Commerce, this international trade publicity newspaper circulates abroad through Canada's Trade Commissioner Service. It provides a free service to companies that wish to export their products or services. Canadian manufacturers having an export capability who are interested in having their products manufactured abroad under license, joint venture or similar arrangements may use Canada Courier to contact potential manufacturing affiliates in foreign countries by having an article included in the issues reaching the markets of interest. Write: The Editor, Canada Courier, Public Information Branch 98, Department of Industry, Trade and Commerce, Ottawa, Ontario K1A 0H5.

COMMERCE CANADA

Le ministère de l'Industrie et du Commerce publie la revue Commerce Canada en français et en anglais six fois par an ainsi qu'un bulletin de nouvelles Commerce Canada. A partir de novembre, le bulletin de nouvelles Commerce Canada renseignera régulièrement les lecteurs sur des projets nouveaux et multilatéraux sélectionnés à l'étranger et approuvés par les banques mondiales et le Programme des Nations Unies pour le développement (PNUD). Les firmes canadiennes désireuses de soumissionner peuvent demander que leur nom figure sur la liste des abonnés à Commerce Canada. Écrire à la rédaction Commerce Canada, Direction de l'information publique (98), ministère de l'Industrie et du Commerce, Ottawa (Ontario) K1A 0H5.

COURRIER CANADIEN

Ce périodique publicitaire sur le commerce international, dont le ministère de l'Industrie et du Commerce publie 22 numéros chaque année en français (3), anglais international (5), anglais américain (5), allemand (3), espagnol (4) et japonais (2), est diffusé à l'étranger par l'entremise du Service des délégués commerciaux du Canada. Il offre un service gratuit aux compagnies désireuses d'exporter leurs produits ou services. Les fabricants canadiens qui ont des compétences en matière d'exportation et qui désirent que leurs produits soient fabriqués à l'étranger par le biais d'un accord de licence, coentreprise ou autre peuvent profiter du service offert. En effet, un article dans les numéros pertinents de Courrier Canadien leur permet d'entrer en contact avec des associés éventuels à l'étranger. Écrire à la rédaction, Courrier Canadien, Direction de l'information publique 98, ministère de l'Industrie et du Commerce, (Ontario) K1A 0H5.

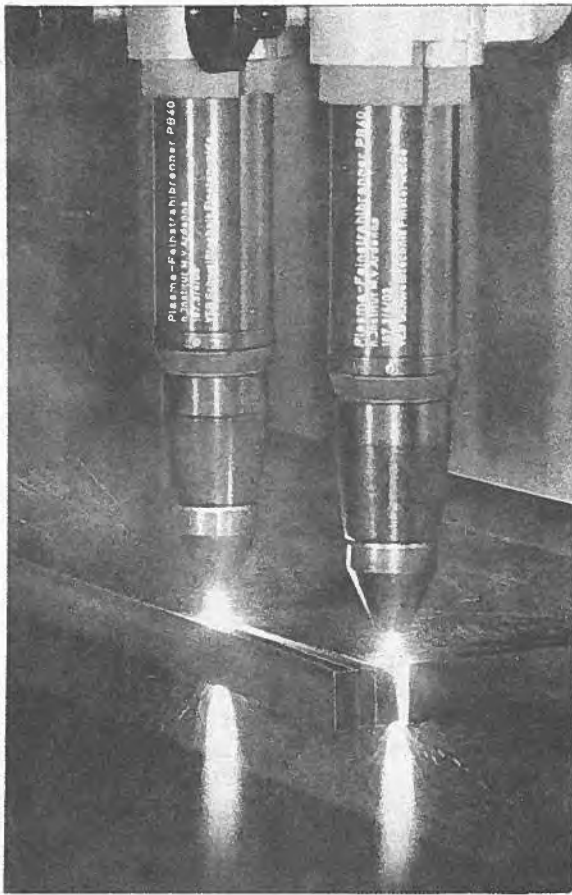

Plasma Arc Cutting
 Découpage à l'arc au plasma



Loose-leaf Binders
 Reliures à feuilles mobiles

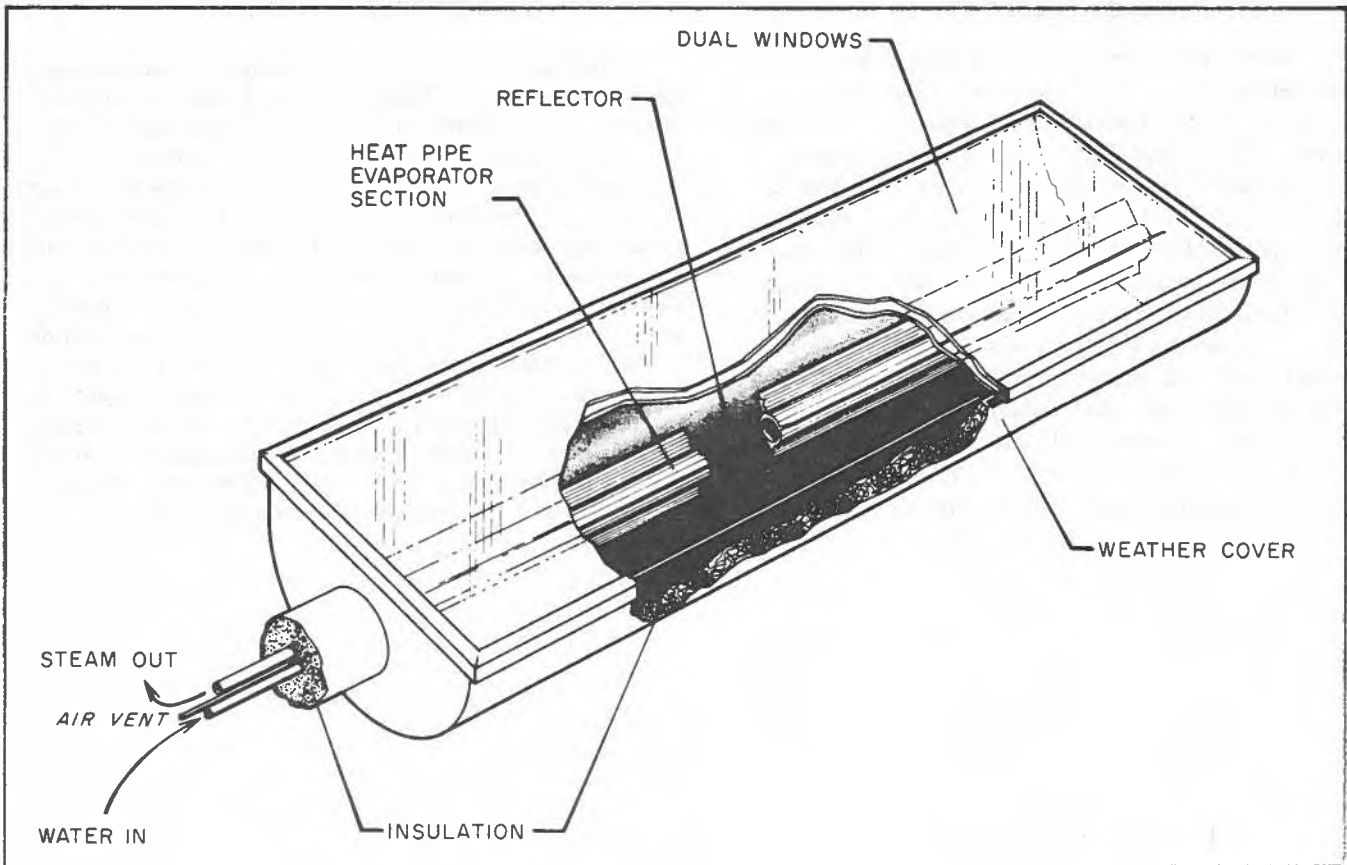

Solar Energy Systems
 Systèmes d'énergie solaire



Rotary Clothes Hoist/Umbrella/Tent
Séchoir à linge rotatif/parapluie/tente

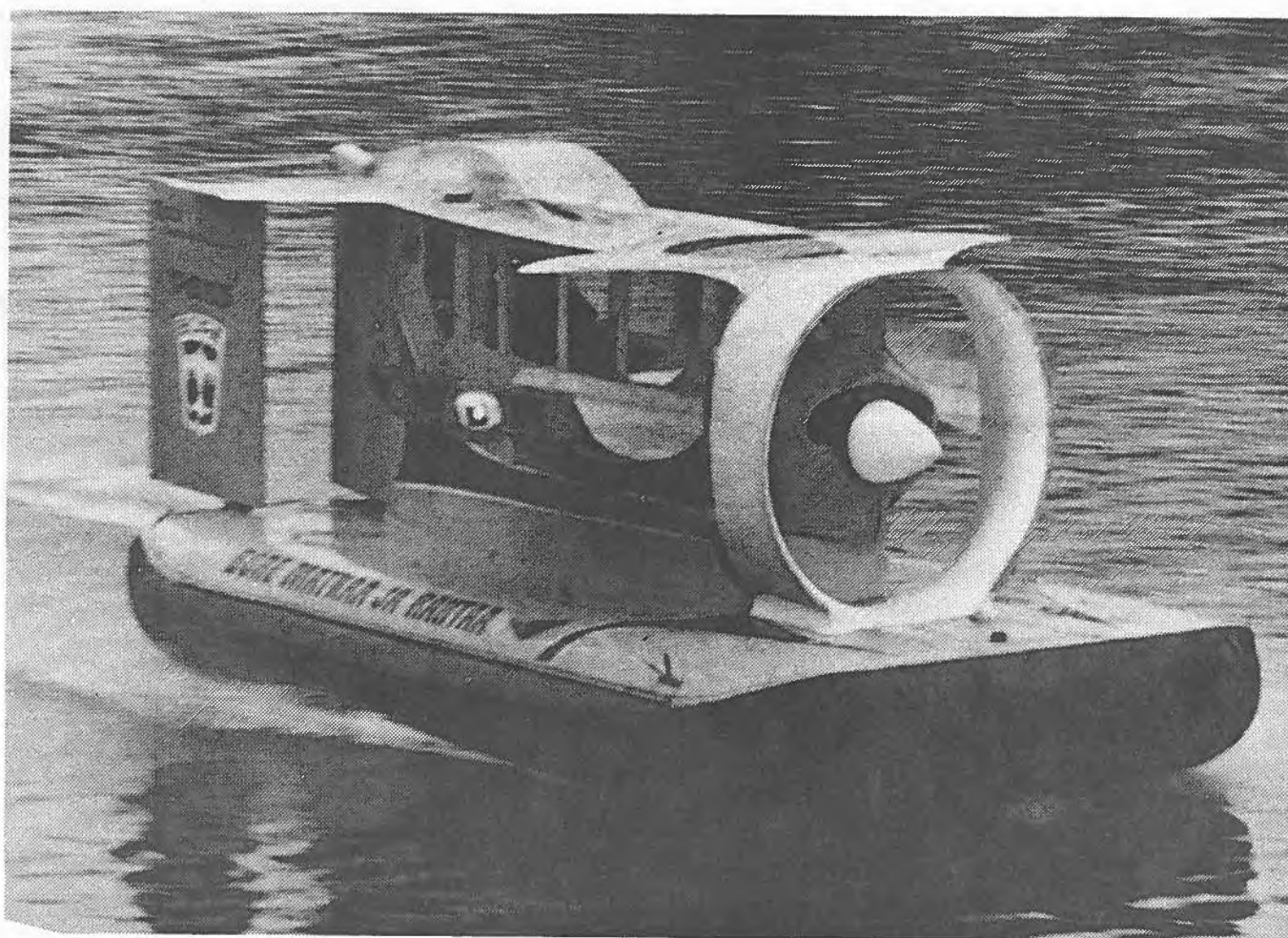

Hovercraft
Aéroglisseur



Carrying Handle
Poignée pour récipients

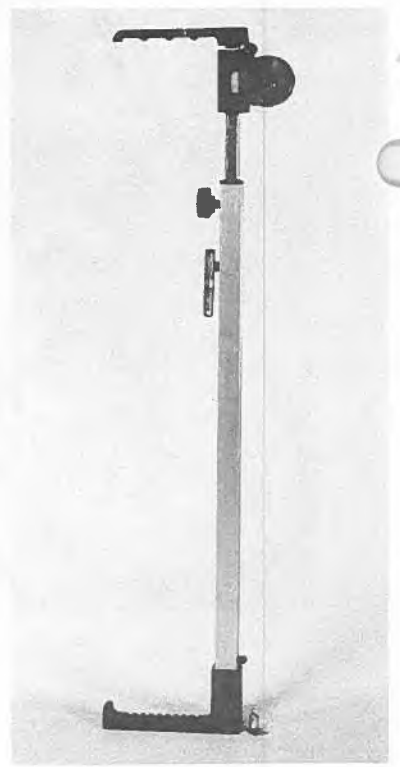

Grade Checker
Outil de vérification du nivellem

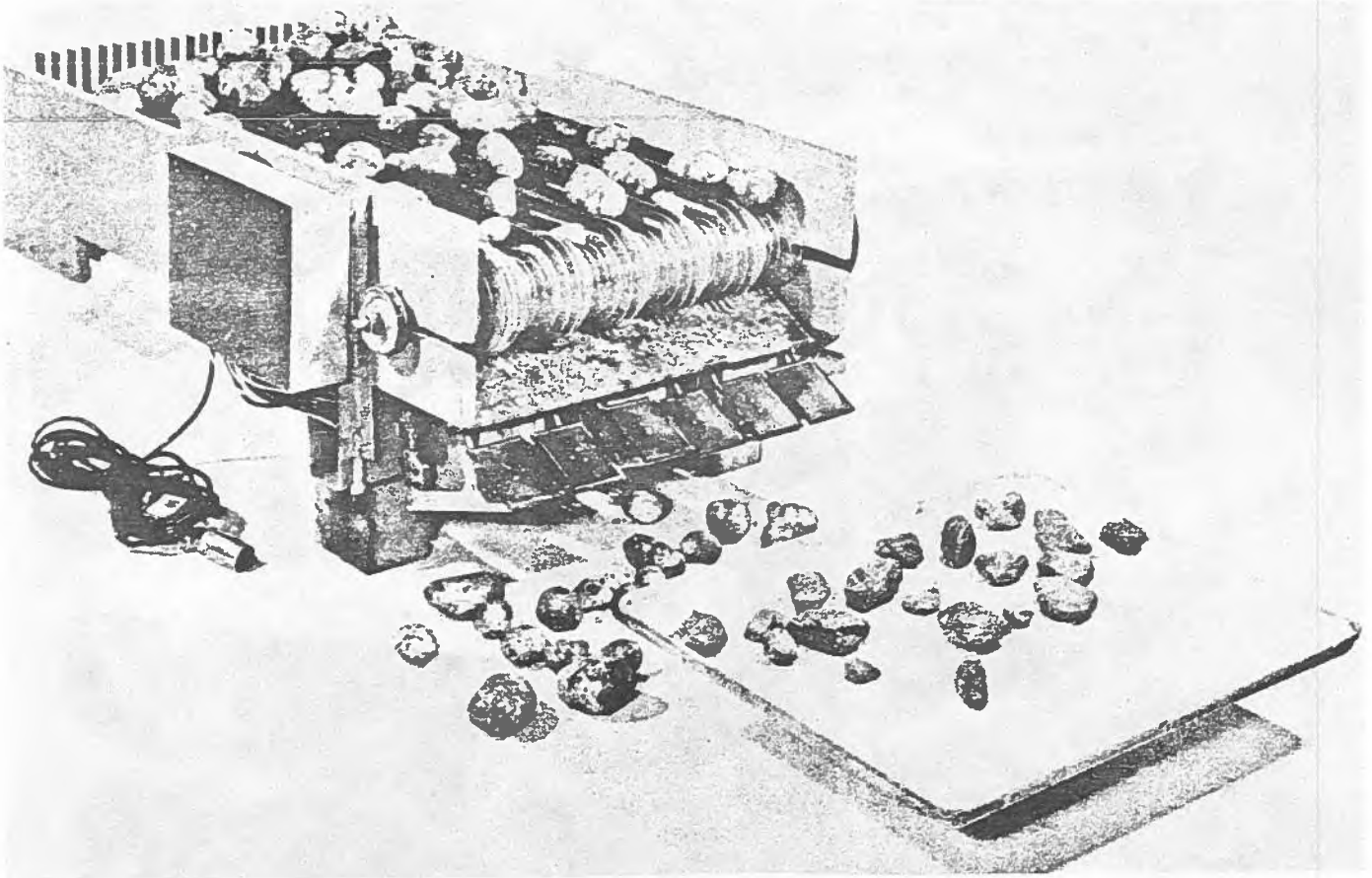

Potato Sorting Equipment
Machine à trier les pommes de terre

