

# new products bulletin

This monthly bulletin is published to inform Canadian industry of licensing and joint venture opportunities that may be investigated for the purpose of forming manufacturing affiliations. The Department cannot assume any responsibility for claims made or for transactions which ensue from the publication of any items in this bulletin. If you are interested in any of the proposals you should contact the correspondent identified with the item and send a copy of your initial correspondence to the Canadian Government Trade Commissioner responsible for the area at the address indicated, in order that he can provide appropriate assistance or commercial information.

The Licensing Opportunities Section (34/3) of the BUSINESS CENTRE of the Department of Industry, Trade and Commerce, Ottawa, Ontario K1A 0H5 (Telephone: (613) 995-5771) should be advised of any agreements concluded as a result of this publicity.

# bulletin de produits nouveaux

Le présent bulletin, publié tous les mois, a pour objet d'informer l'industrie canadienne d'occasions de fabrication sous licence et d'entreprise en participation qu'il est possible d'étudier aux fins de constituer des affiliations manufacturières. Le Ministère ne peut assumer aucune responsabilité à l'égard des réclamations ou transactions découlant de la publication d'articles dans le présent bulletin. Si l'une ou l'autre des propositions vous intéresse, auriez-vous l'obligance de communiquer avec le correspondant et transmettre copie de votre premier échange de correspondance au délégué commercial du Gouvernement du Canada qui s'occupe de la région en cause, à l'adresse indiquée, afin qu'il puisse vous fournir l'aide ou les renseignements commerciaux pertinents.

Prière d'informer la Section des possibilités de licences (34/3), du CENTRE DES ENTREPRISES, ministère de l'Industrie et du Commerce, Ottawa (Ontario) K1A 0H5 (Téléphone: (613) 995-5771), de toute entente intervenue à la suite de la présente publicité.

APRIL 1980

BULLETIN 291

AVRIL 1980

## Ductless Collection of Fumes/291

An electrostatic grid system for confining, collecting or propelling airborne particulate matter to a specific location. The size or number of conventional dust collectors can be reduced, resulting in substantial capital savings. Write: Case 6837, Canadian Patents and Development Limited, 275 Slater Street, Ottawa, Canada K1A 0R3 and send a copy of your initial correspondence to Licensing Opportunities Section (34/3), Business Centre, Department of Industry, Trade and Commerce, Ottawa, Canada K1A 0H5.

## Aerial Self-Propelling Conveyor Device/291

French inventor is seeking affiliates in Canada who would be interested in commercially exploiting his patent rights in the production and sale of an automatic aerial self-propelling traction conveyor device which moves along a suspension cable. As the inventor has not yet granted rights to known interested parties, the following agreements are possible: worldwide assignment of the patent; partial territorial assignment; worldwide international license; partial territorial license. Know-how, drawings, literature, technical skills and prototype will be made available. The device has application in the fields of handling gear; logging equipment; cable car system; ski lifts, etc., and as equipment for erecting high voltage power lines. Its main characteristics are: lightweight, does not require much space, can easily be carried by one person, is comparatively powerful, entirely autonomous and very easy to handle. It

## Système de collecte d'émanations sans conduite/291

Système électrostatique utilisant une grille pour concentrer, recueillir et propulser des particules de matière en suspension dans l'air dans un endroit particulier. La taille ou le nombre de collecteurs de poussières classiques peut être réduit, ce qui permet de réaliser des économies d'argent importantes. Écrire: Cas 6837, Société canadienne des brevets et d'exploitation limitée, 275, rue Slater, Ottawa (Canada) K1A 0R3 et faire parvenir une copie de votre correspondance initiale à la Section des possibilités de licences (34/3), Centre des entreprises, Ministère de l'Industrie et du Commerce, Ottawa (Canada) K1A 0H5.

## Transporteur-tracteur aérien automoteur/291

Un inventeur français cherche au Canada des associés qui seraient intéressés à exploiter commercialement ses droits de brevet pour la production et la vente d'un transporteur-tracteur aérien automoteur automatique se déplaçant sur un câble porteur. Comme il n'a pas encore cédé ses droits à des parties intéressées connues, les accords suivants sont possibles: droits exclusifs de brevet ou de licence, à l'échelle mondiale ou sur un territoire limité. L'inventeur s'engage à fournir son savoir-faire, des plans, de la documentation, des compétences techniques et un prototype. Le dispositif trouve des applications dans les domaines suivants: manutention de marchandises, exploitation forestière, téléféristique, remonte-pentes, etc., et installation de lignes électriques haute tension. Ses principales caractéristiques sont: légèreté, encombrement réduit, autonomie totale, fonctionnement très simple, puissance relativement élevée



Government  
of Canada

Gouvernement  
du Canada

Industry, Trade  
and Commerce

Industrie  
et Commerce



Gouvernement  
du Canada

Government  
of Canada

Industrie  
et Commerce

Industry, Trade  
and Commerce

moves along a stationary cable regardless of the slope of the carrier cable; is self-propelling; is able to draw hawsers along cables set up by the usual means; has the required power for various loads without skidding along the suspension cable; allows for the crossing of coupling boxes, a stopping device and automatic uncoupling of the engine when the distance has been covered as well as a device for automatic uncoupling of the engine in case of engine failure which permits easy retrieval of the machine when pulling the hawser. The parameters indicate a force parallel to the suspension cable of 180 kilogramme force at a rate of 6 kilometers per hour; height — 50 centimeters; width — 35 centimeters; total mass — 14 kilogrammes; cost, including material and engine — approximately 3,000 French Francs. See illustration (1). Write: M. Stelvio Cellai, Ing. Electromécanicien, 56, boul. d'Anvers, Chambre 454, 67000 Strasbourg, France and send a copy of your initial correspondence to Commercial Division, Canadian Embassy, 35 Avenue Montaigne, 75008 Paris, France.

### **Trenchless Placement of Anti-Seepage Barriers/291**

Czechoslovakian Foreign Trade Corporation offers a Canadian company the rights to manufacture and market worldwide, equipment developed by the Research Institute of Amelioration in Prague, used to lay anti-seepage plastic foil troughs in sandy soil for dispersing rainfall or irrigation water to cultivate intensive crops or to create green areas in sandy arid areas. Plastic foil troughs are laid by a special share which can also be used as an exchangeable working unit for trenchless drainage machines. The equipment uncoils the PE foil from a reel which creates trenchless (non-excavating) trough-like barriers in the ground at a depth of 80-100 cm. Simultaneously, pipes for the underground irrigation can be laid. The machine requires one operator and a helper and performs at the equivalent of 800 m/h. Technical assistance, technicians on loan and drawings are offered. Write: Mr. Jan Volny, Polytechna, P.O. Box 834, Panska 9, 112 45 Praha 1, Czechoslovakia and send a copy of your initial correspondence to Commercial Division, Canadian Embassy, Mickiewiczova 6, 125 33 Prague 6, Czechoslovakia.

### **Exterior Wall Insulation System/291**

German firm offers a Canadian company industrial property rights and know-how to manufacture and market insulating boards and plasters for use in an external building insulation system. The system is based on attaching grooved rigid polystyrene foam boards to masonry buildings with Heck adhesives. The adhesives are applied to the back of the insulating board in strips so that the outer grooves are filled. The boards are then stuck to the wall

et facilité de transport par une seule personne. Le dispositif se déplace sur un câble porteur fixe, peu importe la pente. Il est automoteur, peut tirer des câbles de remorquage le long de câbles porteurs déjà installés de la façon habituelle, est assez puissant pour tirer différentes charges sans glisser le long du câble porteur, est conçu pour franchir des manchons d'accouplement, et comporte un dispositif de freinage et de désaccouplement automatique du moteur en fin de parcours ainsi qu'un dispositif de désaccouplement automatique du moteur en cas de panne, permettant de récupérer facilement l'engin en tirant sur le câble de remorquage. Force de traction parallèle au câble porteur de 180 kilogrammes-force à une vitesse de 6 kilomètres à l'heure, hauteur de 50 centimètres, largeur de 35 centimètres, masse totale de 14 kilogrammes. Prix de revient, matériel et moteur compris, de l'ordre de 3 000 francs français. Voir l'illustration (1). Écrire à: M. Stelvio Cellai, ing. électromécanicien, 56, boul. d'Anvers, chambre 454, 67000 Strasbourg (France), et faire parvenir une copie de sa correspondance initiale à la Division commerciale, Ambassade canadienne, 35, avenue Montaigne, 75008 Paris (France).

### **Aménagement sans excavation de canaux anti-infiltration/291**

La Corporation tchécoslovaque de commerce extérieur offre à une compagnie canadienne les droits exclusifs de fabrication et de commercialisation d'une machine mise au point par l'Institut de recherche sur les améliorations de Prague. La machine sert à aménager en sol sablonneux des canaux anti-infiltration à paroi de polyéthylène qui, en répartissant les eaux de pluie ou d'irrigation, permettent de faire de la culture intensive et de créer des zones de verdure dans des régions sablonneuses et arides. Les canaux sont aménagés au moyen d'un soc spécial qui peut aussi servir d'accessoire interchangeable pour les machines de drainage sans excavation. La feuille de polyéthylène, montée sur un dévidoir, est déroulée de façon à former des canaux anti-infiltration de 80-100 cm de profondeur sans que le sol ne soit creusé. Des tuyaux d'irrigation souterraine peuvent être installés au fur et à mesure. La machine fait appel à un opérateur et à un aide, et elle évolue à une vitesse de 800 m/h. De l'aide technique, des techniciens détachés et des plans sont mis à la disposition de l'intéressé. Écrire à: M. Jan Volny, Polytechna, B.P. 834, Panska 9, 112 45 Praha 1 (Tchécoslovaquie), et faire parvenir une copie de sa correspondance initiale à la Division commerciale, Ambassade canadienne, Mickiewiczova 6, 125 33 Prague 6 (Tchécoslovaquie).

### **Système d'isolation des murs extérieurs/291**

Une entreprise allemande offre à une compagnie canadienne les droits de propriété industrielle et son savoir-faire pour la fabrication et la commercialisation de panneaux et d'enduits isolants destinés à un système d'isolation extérieure des bâtiments. Le système consiste à coller des panneaux rigides rainurés en mousse de polystyrène sur des bâtiments en maçonnerie avec des adhésifs Heck. Les adhésifs sont appliqués à l'endos des panneaux isolants,

beginning at fixed guide boards, the ground, or the base of the foundation. A reinforcing mortar, with Heck reinforcing web embedded in it, is applied to the insulating board and a further application of mortar applied so that the total layer is 4-6 mm thick. A thin layer of abrasive, mineral facing, scraping or spray plasters, etc., or coarse plaster, may be applied to the roughened mortar. Fire retardance can be increased by use of EPS panels. Advantages: Savings in fuel costs; cracks are covered up; system is permeable to water vapour; no condensation other than water precipitation — wall can breathe and does not rot from outside; expansion joints are greater distance apart; no hot or cold bridges on account of jointless external insulation, also no dust nor discoloration on inside walls; living area is increased as all additional insulation can be dispensed with — edges of walls, lintels, partitions, etc., are enclosed and protected by the insulating layer; supporting walls need satisfy only the static and weight requirements — outside walls can be thinner and the foundation smaller; summer heat cannot penetrate outside wall and heat caused by the sun shining into a room flows away via the outside walls into the ground; pipes do not freeze up and in the case of hot-water pipes, the heat transmitted to the outside wall remains in the house; outstanding heat storage, etc. See illustration (2). Write: Mr. Friedrich Heck, Dammsystem Heck GmbH, Heckenpfad 15, 6702 Bad Dürkheim, West Germany and send a copy of your initial correspondence to Canadian Consulate General, Immermannstrasse 3, 4 Duesseldorf, West Germany.

### **Pipeline/291**

American agent for U.S. company offers licensing rights in Canada for the manufacture and sale of a pipeline assembly and safety casing system on which U.S. Patent 3,863,679 and Canadian Patent 982,960 have been issued. The system provides for the transportation, below ground or under water, of such materials as petroleum, liquified gas, chemicals, slurries, steam, and high voltage power, in a primary encasement with a secondary safety casing that serves as a containment and recovery vehicle for materials lost in the event of a pipeline leak or rupture. The safety casing includes upper and lower semicircular casing sections formed with channels extending longitudinally and located centrally relative to the outer periphery of the casing section, each section having a flange adapted to receive a seal. The casing is easily removed to facilitate repairs and replacements to the pipes or casing sections or to add additional pipelines and/or control equipment. In the case of power lines, the safety casing protects against external exposure and damage, provides cooling capacities for the lines and safety factors to prevent suspected undesirable radiation hazards. Easy access for repairs or expansion of services, cost effectiveness and reduction or elimination of deep trenching installations, protective corrosion wrapping and insulation sheathing are claimed as advantages over present pipelines design. Write: Pipeline Design Associates, Inc., P.O. Box 910, Beacon, New York

par bandes, de façon à remplir les rainures extérieures. Les panneaux sont ensuite collés au mur à partir de planches guides fixes, du sol ou de la base de la fondation. Un mortier armé d'un treillis Heck est appliqué sur le panneau isolant et recouvert d'une autre couche de mortier, portant l'épaisseur totale du panneau à 4-6 mm. Le mortier rendu rugueux peut être recouvert d'une mince couche d'enduit abrasif ou d'une couche épaisse d'enduit à surface minérale, à gratter, projeté, grossier, etc. On peut augmenter la résistance au feu en utilisant des panneaux de polystyrène expansé. Avantages: économies de chauffage; fissures bouchées; perméabilité à la vapeur d'eau; aucune condensation autre que les précipitations (le mur respire et ne pourrit pas de l'extérieur); joints d'expansion plus distancés; élimination des ponts thermiques grâce à une isolation extérieure sans joint; espace utile accru grâce à l'élimination d'isolant supplémentaire (la couche isolante enveloppe et protège les extrémités des murs, les linteaux, les cloisons, etc.); les murs de support n'ont qu'à satisfaire aux contraintes statiques et de charge (réduction de l'épaisseur des murs extérieurs et de la fondation); en été, la chaleur ne peut pénétrer les murs extérieurs et, sous un soleil de plomb, la chaleur accumulée dans une pièce s'échappe par les murs extérieurs, dans le sol; les tuyaux ne gèlent pas, et la chaleur dégagée par les tuyaux d'eau chaude et absorbée par les murs extérieurs ne s'échappe pas de la maison; capacité de stockage thermique inégalée, etc. Voir l'illustration (2). Écrire à: M. Friedrich Heck, Dammsystem Heck GmbH, Heckenpfad 15, 6702 Bad Dürkheim, (R.F.A.), et faire parvenir une copie de sa correspondance initiale au Consulat général canadien, Immermannstrasse 3, 4 Duesseldorf (R.F.A.).

### **Canalisation/291**

Un agent d'une compagnie américaine offre les droits de licence au Canada pour la fabrication et la vente d'un système de canalisation et d'enveloppe de sécurité qui est protégé par le brevet américain 3 863 679 et le brevet canadien 982 960. Le système permet le transport souterrain ou sous-marin de substances comme du pétrole, du gaz liquéfié, des produits chimiques, des boues, de la vapeur et des lignes haute tension, dans une canalisation logée dans une enveloppe de sécurité qui sert à contenir et à récupérer la substance déversée en cas de fuite ou de rupture dans la canalisation. Chaque section de l'enveloppe de sécurité est formée de deux parties, supérieure et inférieure, semi-circulaires, qui comportent chacune, au point milieu de leur périphérie, un canal longitudinal et dont les bords forment des brides conçues pour recevoir des joints d'étanchéité. On peut facilement démonter l'enveloppe pour réparer ou remplacer une section de canalisation ou d'enveloppe, ou pour ajouter d'autres canalisations ou du matériel de contrôle. Dans le cas de lignes électriques, l'enveloppe assure une protection contre une exposition et des dommages externes, permet l'installation d'un système de refroidissement des lignes et présente des caractéristiques de sécurité éliminant tout danger éventuel associé à certains rayonnements. Selon l'inventeur, ce type de canalisation est supérieure aux modèles actuels quant aux aspects suivants: accessibilité facilitant les réparations ou l'expansion

12508 and send a copy of your initial correspondence to Canadian Consulate General, 1251 Avenue of the Americas, New York City, N.Y. 10020.

#### **Autoclaves/291**

British firm offers the licensing rights to a Canadian company to manufacture and market exclusively in Canada and non-exclusively in the United States, its complete range of autoclaves used in hospitals, laboratories, R&D and the manufacture of pharmaceuticals. Full specifications, engineering drawings and know-how will be provided. The range of autoclaves includes sizes from .182 m<sup>3</sup> capacity to 5.6 m<sup>3</sup> capacity with single or double doors and with multi-cycles for sterilizing a variety of products. Write: Chas. F. Thackray Ltd., Sterilizer Division, St. Anthony's Road, Leeds LS11 8DT, England and send a copy of your initial correspondence to Commercial Division, Canadian High Commission, One Grosvenor Square, London, W1X 0AB, England.

#### **Mini Bob/291**

West German manufacturer offers a Canadian company a manufacturing license and the marketing rights for the Canadian, American and Japanese markets for its blow molded polyethylene steerable mini-bob sleds which are easy to stop and have no sharp edges. The Mini Bob weighs 2.3 kg, is 48-50 cm long and 30-35 cm wide. Patents, technical know-how and an advertising film are available. The licensing fee is to be based on the number of pieces manufactured with an annual minimum output requirement. See illustrations (3). Write: Loger Sportartikel Fabrikation und Vertriebs GmbH, Waldschmidtstr. 8 c, Postfach 221, D-8132 Tutzing, West Germany and send a copy of your initial correspondence to Canadian Consulate General, Immermannstrasse 3, 4 Duesseldorf, West Germany.

#### **Water Purification/Pre-treatment Apparatus/291**

Hungarian foreign trade company for development and commercialization of inventions offers a Canadian company the licensing rights to manufacture and market a water treatment system in which solid and floating matters and oil content can be simultaneously removed from water. The main feature of the filter is the possibility of removing all contaminations simultaneously in one single operation. The floating matter as well as the oil content can be reduced by using the filter to a figure below 1 mg/l. The equipment works on a large scale. The use of the filter has the following advantages: lower investment and operational costs; smaller water loss; reduced number of operating personnel and the possibility for a high level of automation and for the conversion of existing plants. One filter system has

des services, rentabilité et réduction ou élimination des installations dans des tranchées profondes, enveloppe anti-corrosion et gaine isolante. Écrire à: Pipeline Design Associates, Inc., B.P. 910, Beacon (New York) 12508, et faire parvenir une copie de sa correspondance initiale au Consulat général canadien, 1251 Avenue of the Americas, New York (N.Y.) 10020.

#### **Autoclaves/291**

Une entreprise britannique offre à une compagnie canadienne les droits de licence pour la fabrication et la commercialisation exclusives au Canada et non exclusives aux États-Unis de sa gamme complète d'autoclaves qui trouvent des applications dans les hôpitaux, dans les laboratoires, en R et D et dans la fabrication des produits pharmaceutiques. Toutes les caractéristiques, les plans techniques et le savoir-faire seront fournis. La capacité des appareils varie entre .182 m<sup>3</sup> et 5.6 m<sup>3</sup>. On trouve des modèles à une ou deux portes, et des modèles à plusieurs cycles pour la stérilisation de différents produits. Écrire à: Chas. F. Thackray Ltd., Sterilizer Division, St. Anthony's Road, Leeds LS11 8DT (Angleterre), et faire parvenir une copie de sa correspondance initiale à la Division commerciale, Haut-commissariat canadien, One Grosvenor Square, Londres, W1X 0AB (Angleterre).

#### **Mini-bob/291**

Un fabricant ouest-allemand offre à une compagnie canadienne une licence de fabrication et les droits de commercialisation, sur les marchés canadien, américain et japonais, de ses mini-bobsleighs dirigeables en polyéthylène moulé par soufflage qui sont faciles à arrêter et ne comportent aucune arête coupante. L'invention pèse 2,3 kg, mesure 48-50 cm de longueur et 30-35 cm de largeur. Les brevets, le savoir-faire technique et un film publicitaire sont disponibles. Les frais de licence seront fonctions du nombre d'unité fabriquées qui ne doit pas être inférieur à un seuil minimal annuel. Voir l'illustration (3). Écrire à: Loger Sportartikel Fabrikation und Vertriebs GmbH, Waldschmidtstr. 8 c, Postfach 221, D-8132 Tutzing (Allemagne de l'Ouest), et faire parvenir une copie de sa correspondance initiale au Consulat général canadien, Immermannstrasse 3, 4 Duesseldorf (Allemagne de l'Ouest).

#### **Appareil de prétraitement-purification de l'eau/291**

La compagnie hongroise de commerce extérieur pour le développement et la commercialisation des inventions offre à une compagnie canadienne les droits de licence pour la fabrication et la commercialisation d'un système de traitement de l'eau qui permet d'éliminer simultanément les matières solides et flottantes, et les huiles de l'eau. La principale caractéristique du filtre est qu'il est capable d'éliminer tous les contaminants simultanément en une seule opération. Le filtre peut réduire à moins de 1 mg/L la teneur en matières flottantes et en huiles. Le matériel fonctionne sur une grande échelle. Le filtre présente les avantages suivants: investissement et coûts d'exploitation faibles; perte d'eau réduite; réduction du personnel d'exploitation et possibilité d'automatisation accrue et de

been working since 1978 with an output of 30 t/h. The filter is suitable for reuse in repeated applications of condensates in industrial plants, power station turbines and industrial boilers as well as for fine filtration of sewage. Write: Novex Code: 9038, Messrs. L. Magocsi and Cs. Laskai, Novex, P.O.B. 62, H-1364 Budapest, Hungary and send a copy of your initial correspondence to Commercial Division, Canadian Embassy, Budakeszi ut 55/dP/8, 1021 Budapest, Hungary.

#### **Pocket-Size Fire Escape and Rescue Device/291**

Canadian inventor offers licensing rights, technical advice, and American and Canadian patents, to a Canadian company to manufacture and market in North America, his pocket-size portable box consisting of gears and rollers in brass, steel and nylon to be used in conjunction with a 4 mm simple harness and braided steel rope for the purpose of providing a secondary means of exit from high rise buildings, and for rescue operations from above, of those trapped in alpine situations, gondolas, etc. The device incorporates weight settings with an indicator on the outside of the machine as well as automatic and manual brakes. Any number of persons owning this device may use the same cable; adults, children, animals in nets, incapacitated stretcher cases, the elderly or by those finding it necessary to carry others. See illustration (4). Write: Mrs. Jane Adams, 5425 Ewart Street, Burnaby South, B.C. V5J 2W6 and send a copy of your initial correspondence to Licensing Opportunities Section (34/3), Business Centre, Department of Industry, Trade and Commerce, Ottawa, Ontario K1A 0H5.

#### **Safe Slide/291**

British company seeks a Canadian company to manufacture and market, under license in Canada, its jumbo safety slides constructed in multiples of 2.3 m and .3 m - 1.2 m wide to any length required to fit site's ground contours. The slide can be manufactured from steel, wood, fibreglass, concrete, etc., to which appropriate lengths of a special CNR4 rubber material are affixed with adhesive to provide a fairly fast, cushioned surface that does not cause friction burns. Also, the slide is safe in that it is built on the ground, has cushioned sides, no sharp edges and uses no nails nor screws. The rubber surfacing can also be supplied in any length, .3 m - 1.2 m wide for resurfacing old slides permanently. The licensor will supply the rubber surfacing material, drawings, know-how and advertising art work or permit reproduction of such literature. See illustration (5). Write: Mr. F. Canning, Canning Leisure, Sandy Lane Industrial Site, Worksop, Nottinghamshire, England and send a copy of your initial correspondence to Commercial

transformation des usines existantes. Un de ces systèmes, en service depuis 1978, traite 30 t/h. Le filtre est utilisable lorsqu'on procède à des applications répétées de condensats dans des installations industrielles, dans des turbines de centrales électriques et dans des chaudières industrielles, ainsi que lorsqu'on procède à une filtration poussée des eaux usées. Écrire à: Code Novex: 9038, MM. L. Magocsi et Cs. Laskai, Novex, B.P. 62, H-1364 Budapest (Hongrie), et faire parvenir une copie de sa correspondance initiale à la Division commerciale, Ambassade canadienne, Budakeszi ut 55/dP/8, 1021 Budapest (Hongrie).

#### **Descendeur de secours portatif/291**

Un inventeur canadien offre à une compagnie canadienne les droits de licence, des conseils techniques et les brevets américain et canadien pour la fabrication et la commercialisation, en Amérique du Nord, de son descendeur portatif. Il s'agit d'un ensemble d'engrenages et de rouleaux en laiton, en acier et en nylon qui, avec un harnais simple de 4 mm et un câble d'acier tressé, constitue un autre moyen de sortir, en cas d'urgence, des édifices en hauteur et de mener à bien des opérations aériennes de sauvetage de personnes prises en montagne, dans une cabine de téléphérique, etc.. Le dispositif comporte des réglages du poids avec un indicateur sur la partie extérieure de l'appareil, ainsi que des freins automatique et manuel. Le même câble peut porter autant de personnes munies de ce dispositif qu'il y a de dispositifs, qu'il s'agisse d'adultes, d'enfants, d'animaux suspendus dans des filets, d'handicapés étendus sur des civières, de personnes âgées ou de personnes qui jugent nécessaire de porter quelqu'un. Voir l'illustration (4). Écrire à Mme Jane Adams, 5425, rue Ewart, Burnaby South (C.-B.), V5J 2W6 et faire parvenir une copie de sa correspondance initiale à la Section des possibilités de licences (34/3), Centre des entreprises, ministère de l'Industrie et du Commerce, Ottawa (Ontario) K1A 0H5.

#### **Toboggan sécuritaire/291**

Une compagnie britannique cherche une société canadienne pour fabriquer et mettre sur le marché, sous licence canadienne, ses toboggans géants, de conception sécuritaire, construits en sections de 2,3 m et de 0,3 m à 1,2 m de largeur; ces toboggans peuvent réunir autant de section qu'il est nécessaire pour couvrir la longueur de l'emplacement choisi. Le toboggan peut être fabriqué en acier, en bois, en fibre de verre, en béton, etc., matière sur laquelle on fixe, à l'aide d'adhésif, un recouvrement en caoutchouc spécial CNR4 afin d'offrir une surface rembourée et relativement rapide qui ne causera pas de brûlures par friction. Le toboggan est sécuritaire puisqu'il est construit sur le sol, est muni de rebords rembourrés, ne possède aucune partie saillante et ne requiert pas de clous ou de vis pour l'assemblage. Le recouvrement en caoutchouc peut être également fourni dans diverses longueurs, et de 0,3 m à 1,2 m de largeur pour recouvrir en permanence les vieux toboggans. Le concédant du brevet fournira le recouvrement en caou-

Division, Canadian High Commission, One Grosvenor Square, London, W1X 0AB, England.

### **Wheels/291**

West German company offers the Canadian manufacturing and marketing rights for wheels used in babies and dolls' prams, etc. The method involves a turning lock with a protectively closed cap and a special manufacturing procedure, using no welding, which permits the use of chromium and zinc coated materials. Technical know-how is available. A patent has been applied for in Canada. Write: MORA GmbH, Moderner Radbau 31 27 31, Matthiasstr. 11, 8500 Nurnberg, West Germany and send a copy of your initial correspondence to: Canadian Consulate General, Immermannstrasse 3, 4 Duesseldorf, West Germany.

### **Outerwear/291**

American manufacturer with projected sales of U.S. \$1.8 million for 1980 seeks a Canadian company to manufacture and sell its line of outerwear in Canada under a licensing arrangement or joint venture partnership. The Canadian company should have technical know-how and currently be selling to the ski wear and outdoor apparel market. The line includes children's, ladies and men's down and Antron<sup>®</sup> filled vests of leather or nylon or combinations thereof, sheepskin colour co-ordinated collars, Gore Tex<sup>®</sup> nylon and/or leather parkas and jackets, ski-bibs with stretch knit side panels, gaitors and wind shirts. All products except the all-leather down vest and the Ultimate down vests are washable. See illustration (6). Write: Rocky Mountain Featherbed Co., P.O. Box 536, Jackson, Wyoming 83001 and send a copy of your initial correspondence to Canadian Consulate General, One Maritime Plaza, Alcoa Building, Suite 1100, Golden Gateway Center, San Francisco, California 94111.

### **Adjustable Gripping Socket/291**

American inventor offers the Canadian manufacturing and marketing rights to a patented adjustable socket for removing, for example, stripped hexagonal Allen sockethead bolts, studs and completely rounded shafting by a gripping action which increases until the nut loosens or the bolt shears. It will grip any shape head in all American standard and most metric sizes. The socket is composed of three elements: the outer housing, grooved pins and a plastic pin retainer. A number of cam faces on the inside of the housing allow a gripping action in both directions. The plastic pin retainer is pressed into the socket housing with a light

tchouc, les dessins, le savoir-faire et les documents publicitaires ou en permettra la reproduction. Voir l'illustration (5). Écrire à: M. F. Canning, Canning Leisure, Sandy Lane Industrial Site, Worksop, Nottinghamshire, Angleterre, en faisant parvenir une copie de votre correspondance initiale à la Division commerciale, Haut-commissariat du Canada, 1 Grosvenor Square, Londres, W1X 0AB, Angleterre.

### **Roues/291**

Une compagnie ouest-allemande offre les droits de fabrication et de commercialisation, au Canada, de roues pour landaus d'enfant et de poupée, etc. L'invention comporte un verrou tournant protégé par un capuchon fermé, et fait appel à un procédé de fabrication spécial, sans soudure, qui permet l'emploi de matériaux à revêtement de chrome et de zinc. Le savoir-faire technique est disponible. Une demande de brevet a été déposée au Canada. Écrire à: MORA GmbH, Moderner Radbau 31 27 31, Matthiasstr. 11, 8500 Nurnberg (Allemagne de l'Ouest), et faire parvenir une copie de sa correspondance initiale au Consulat général du Canada, Immermannstrasse 3, 4 Duesseldorf (Allemagne de l'Ouest).

### **Vêtements de dessus/291**

Un fabricant américain dont les ventes pour 1980 sont évaluées à \$1.8 millions U.S. recherche une compagnie canadienne intéressée dans la fabrication et la vente de sa gamme de vêtements de dessus, au Canada; il offre soit des droits de licence, soit une coparticipation à son entreprise. La compagnie canadienne doit posséder le savoir-faire technique et vendre actuellement au marché du vêtement de dessus et du vêtement de ski. La gamme de produits comprend des gilets en cuir et (ou) nylon, doublés de duvet et d'Antron M.D., pour enfants, femmes et hommes, des collets de mouton aux couleurs assorties, des anoraks et des vestes en nylon Gore Tex M.D. et (ou) en cuir, des combinaisons de ski aux côtés en tissu extensible, des guêtres et des coupe-vent. Tous les produits, sauf le gilet tout cuir doublé de duvet et les gilets doublés de duvet Ultimate, sont lavables. Voir l'illustration (6). Écrire à: Rocky Mountain Featherbed Co., B.P. 536, Jackson (Wyoming) 83001 et faire parvenir une copie de sa correspondance initiale au Consulat général canadien, One Maritime Plaza, Alcoa Building, Suite 1100, Golden Gateway Center, San Francisco (Californie) 94111.

### **Douille de serrage réglable/291**

Un inventeur américain offre les droits canadiens de fabrication et de commercialisation d'une douille réglable brevetée pour la dépose, par exemple, de boulons à six pans creux mâles foirés, des goujons et des arbres complètement arrondis grâce à un effet de grippage qui va en croissant jusqu'à ce que l'écrou se desserre ou que le boulon se casse. Elle s'adapte à toutes les formes de tête de tous les calibres normalisés et de la plupart des calibres métriques. La douille se compose de trois éléments: le logement extérieur, les goupilles cannelées et un arrêtoir de goupilles en

press fit, and the grooved pins snap into the socket so that the groove of the pin fits over the land of the retainer. Thus, they are free to tilt and roll, but cannot fall out. A lead-in taper on the pins allows for easy replacement. Only needle nose pliers are needed. Fitting the standard drive ratchet wrench, the socket operates on the principles of a slip clutch, using a number of cam faces. The pins grip the nut across the flats, and because they are free to tilt and roll, increase their grip as force is applied to the ratchet handle. The sum of the moments about each pin equals the torque applied to the socket wrench. As this torque is increased, the pins ride up the cam face, becoming wedged in the space between the nut and housing. The torque applied to the socket is thus transferred to the nut, eventually overcoming resisting torque of the nut. Under a severe load, the pins give first because their Rockwell hardness is less than that of the socket housing which has been tested to 417 kg/m before breaking. This figure is based on a machined socket. A forged socket should be capable of a torque of 446.4 kg/m. See illustration (7). Write: Mr. Richard H. Young, 212 Andover Road, Billerica, Massachusetts 01821 and send a copy of your initial correspondence to Canadian Consulate General, 500 Boylston Street, Boston, Massachusetts 02116.

#### **Ultrasound Liquid Analyser UAR-3/291**

Czechoslovakian Foreign Trade Corporation and Technical Cooperation Agency offers licensing rights to a Canadian company to manufacture and market (except in South Africa, the People's Republic of China, Israel and CMEA countries) an apparatus for quantitative analysis in colourimetry, refractometry, conductometry by an ultrasonic method. Its application is as a measuring transducer in automatic control systems. The probe can be placed directly in a concentrated liquid; does not require any attendance and operates automatically thus giving continuous readings of the state of the medium to be analysed. It can be applied to advantage in checking and regulating the concentration of ammonia water, glycerol, nitric acid, sulphuric acid and in differentiating between crude oil products such as gasoline and petroleum. For facilitating the manufacture of this analyser, licensee can be provided with technical assistance, service, consultation, documentation and plug-in cards of electronic circuits. See illustration (8). Write: Mr. Jan Valny, Polytechna, P.O. Box 834, Panska 9, 112 45 Praha 1, Czechoslovakia and send a copy of your initial correspondence to Commercial

plastique. Plusieurs faces de came à l'intérieur du logement permettent un effet de grippage dans les deux sens. L'arrêtoir de goupilles en plastique est enfoncé dans le logement de la douille avec un léger emmanchement à la presse, et les goupilles cannelées pénètrent dans la douille de sorte que la cannelure de la goupille s'adapte sur la partie en relief de l'arrêtoir. Ainsi, elles sont libres de basculer et de rouler, mais ne peuvent pas tomber. Le remplacement des goupilles est facilité par une conicité d'entrée. Seules des pinces à bec effilé sont nécessaires. Une fois adaptée une clé à cliquet courante, la douille fonctionne selon le principe de l'accouplement à glissement, en utilisant plusieurs faces de came. Les goupilles serrent l'écrou sur les pans et parce qu'elles sont libres de basculer et de rouler, elles resserrent leur étreinte au fur et à mesure que la force s'exerce à la poignée à rochet. La somme des moments de chaque goupille est égal au couple exercé sur la clé à douille. Lorsque ce couple augmente, les goupilles remontent la face de came et viennent se coincer dans l'espace compris entre l'écrou et le logement. Le couple exercé sur la douille est ainsi transféré à l'écrou et finit par vaincre le couple résistant de l'écrou. Dans le cas d'une forte charge, les goupilles cèdent les premières parce que leur degré de dureté Rockwell est inférieur à celui du logement de douille dont les essais ont montré qu'il pouvait résister à un couple de 417 kg/m avant d'atteindre son point de rupture. Ce chiffre a été établi à partir d'une douille usinée. Une douille forgée doit être capable de supporter un couple de 446.4 kg/m à 521 kg/m. Voir l'illustration (7). Écrire à: Monsieur Richard H. Young, 212 Andover Road, Billerica, Massachusetts 01821 et envoyer un exemplaire de votre correspondance initiale au Consulat général du Canada, 500 Boylston Street, Boston (Massachusetts) 02116.

#### **Analyseur de liquide par ultrasons UAR-3/291**

L'Agence tchécoslovaque de commerce extérieur et de coopération technique offre à une compagnie canadienne des droits de licence pour la fabrication et la commercialisation (sauf en Afrique du Sud, en République populaire de Chine, en Israël et dans les pays du C.A.E.M.) d'un appareil d'analyse quantitative (colorimétrie, réfractométrie et conductimétrie) qui utilise les ultrasons. L'appareil sert comme transducteur de mesure dans des systèmes de commande automatique. La sonde peut être immergée directement dans un liquide concentré, n'appelle aucune surveillance et fonctionne automatiquement; elle permet donc de prendre des mesures continues de l'état de la solution à l'étude. On peut utiliser l'appareil pour contrôler et régler la concentration d'ammoniaque, de glycérol, d'acide nitrique et d'acide sulfurique, et pour établir la distinction entre le pétrole brut et ses dérivés comme l'essence. Pour faciliter la fabrication de l'analyseur, différents services ont été mis à la disposition du titulaire du brevet: aide technique, consultation, documentation et plaquettes de circuits électroniques enfichables. Voir l'illustration (8). Écrire à M. Jan Valny, Polytechna, B. P. 834, Panska 9, 112 45 Praha 1,

Division, Canadian Embassy, Mickiewiczova 6, 125 33  
Prague 6, Czechoslovakia.

#### **Cement Substitute/291**

Guatemalan inventor offers the Canadian manufacturing and marketing rights to "Serratex" a non-petroleum chemical substitute for cement used in all fields of construction: houses, roads, runways, pre-fab panels; blocks and bricks; as insulating, sealing; soundproofing; waterproofing and acidproofing materials. The set time of "Serratex" is two hours with complete curing in five days. "Serratex" of 25.4 mm thickness is claimed to: 1) be equal to 76.2 mm of fibreglass insulation and, 2) cost \$0.243 per .8 m<sup>2</sup>. The licensee is offered the catalyst, technical know-how, technicians on loan and assistance in setting up plants and obtaining equipment. Write: Mr. J.W. Sterling, 19 Calle #14-60, Zona 10, Guatemala City, Guatemala, C.A. and send a copy of your initial correspondence to Commercial Division, Canadian Embassy, Galerias Espana, 6th Floor, 7 Avenida 11-59, Zona 9, Guatemala City, Guatemala, C.A.

---

---

#### **CORRECTION**

---

---

#### **Styrofoam Boxes/288**

The reference to Styrofoam Boxes/288 published in the January, 1980 issue of the New Products Bulletin is not appropriate. It is suggested that these boxes be manufactured from an expanded polystyrene called Styropor® registered to BASF Canada Inc. Styrofoam is a Registered Trade Mark in Canada of the Dow Chemical Company of Canada. We regret this generic use of the Styrofoam Trade Mark.

Tchécoslovaquie et faire parvenir une copie de votre correspondance initiale à la Division commerciale, Ambassade canadienne, Mickiewiczova 6, 125 33 Prague 6, Tchécoslovaquie.

#### **Ciment de remplacement/291**

Un inventeur guatémaltèque offre au marché canadien les droits de fabrication et de commercialisation du "Serratex", produit chimique non pétrolier de remplacement du ciment qui peut être utilisé dans tous les domaines de la construction: habitation, routes, pistes d'atterrissage, panneaux préfabriqués; blocs et briques; isolation thermique et calfeutrage; isolation acoustique; matériaux à l'épreuve de l'eau et des acides. Le "Serratex" prend en deux heures et durcit complètement en cinq jours. L'inventeur prétend que 25.4 mm de "Serratex" (1) équivaut à d'isolant en fibre de verre et (2) coûte \$0.243 par 0,8 m<sup>2</sup>. On offre au titulaire éventuel d'une licence, le catalyseur, le savoir-faire technique, les services de techniciens détachés et de l'aide pour mettre sur pied des usines et obtenir le matériel. Écrire à: M. J.W. Sterling, 19 Calle #14-60, Zona 10, Guatemala (Guatemala) et faire parvenir une copie de sa correspondance initiale à la Division commerciale, Ambassade canadienne, Galerias Espana, 6e étage, 7 Avenida 11-59, Zona 9, Guatemala (Guatemala).

---

---

#### **CORRECTION**

---

---

#### **Boîtes de styromousse/288**

Le résumé sur les Boîtes de styromousse/288, publié dans le numéro de janvier 1980 du Bulletin de produits nouveaux comporte une erreur. Il est suggéré de fabriquer ces boîtes en un polystyrène expansé appelé Styropor M.D., marque déposée de BASF Canada Inc.. Le Styrofoam est une marque déposée, au Canada, de la Dow Chemical Company of Canada. Nous regrettons l'emploi de la marque déposée Styrofoam comme générique.

**RÉSUMÉS OF THE FOLLOWING CANADIAN PATENTS AND UNITED STATES PATENT APPLICATIONS AVAILABLE FOR LICENSING ARE PUBLISHED IN THE LANGUAGE OF APPLICATION, ENGLISH OR FRENCH.**

**DES RÉSUMÉS DES BREVETS CANADIENS CI-JOINTS ET DES DEMANDES DE BREVETS AMÉRICAINS POUR L'OCTROI DE LICENCES SONT PUBLIÉS DANS LA LANGUE DE LA DEMANDE DE BREVET, EN ANGLAIS OU EN FRANÇAIS.**

**Electrical Appliance Cord Storage**

**1,070,913/291**

**Logement à rappel de cordon d'un appareil électrique**

An electrical appliance, for example a vacuum cleaner, is provided with a handle having an elongate hollow interior serving as a storage space for a resiliently self-coiling insulated electrical conductor cord. Write: Paul Mortelmans, 2030 Winrock No. 514, Houston Texas 77057, U.S.A.

**Metal Proportioning Device for Pressure Casting**

**1,070,924/291**

**Dispositif de dosage du métal de la coulée sous pression**

Dispositif d'alimentation d'un moule en métal fondu grâce à une pompe immergée dans un creuset ou dans un four de maintien comportant sur le trajet ascendant conduisant à la pompe une dérivation conduisant à un bassin de niveau réglable. La position du bassin de niveau détermine la pression métallostatique en tout point de la canalisation d'alimentation et le niveau du métal fondu dans la canalisation en particulier. Application à la coulée de l'aluminium sous basse et haute pressions. Écrire: Groupement pour les Activités Atomiques et Avancées "GAAA" S.A., 20 avenue Edouard Herriot, 92350 Le Plessis Robinson, France

**Méthode et appareil de contrôle du rayonnement lumineux**

**1,070,972/291**

**Method and Apparatus for Monitoring Optical Radiation**

A biologically weighted ultraviolet radiant energy monitor providing a direct indication of the hazards to humans from the energy emanating from an optical radiation source. Write: United States Department of Commerce, Washington, D.C. 20230, U.S.A.

**Stud Extractor**

**1,070,991/291**

**Extracteur de goujons**

A torque transmitting device for insertion into a bore in a workpiece, the device being, for example, a stud extractor, having slots spaced around the periphery of a shaft and extending longitudinally of the shaft, each of the slots having a bottom surface inclined towards the periphery of the shaft, and a workpiece-engaging blade in each of the slots. Write: Michael Dorosh, Box 65, Boyle, Alberta, T0A 0M0, Canada

**Corrugated Board Adhesive**

**1,071,085/291**

**Colle pour carton ondulé**

A method for producing a water-resistant combined corrugated board employing a cold cure adhesive based on an aqueous dispersion of a water insoluble synthetic homopolymer of vinyl acetate containing a cross-linkable material to which a cross-linking agent is added prior to use. Write: Dural Products Limited, 550 Marshall Avenue, Dorval, Quebec, H9P 1C9, Canada

**Method for Improving the Sedimentation and Filterability of Coal-derived Liquids**

**1,071,129/291**

**Méthode pour améliorer les caractéristiques de sédimentation et de filtration de liquides dérivés du charbon**

An improvement in the separation of suspended solids from coal-derived liquids by a separations process in which solids size as a separations parameter is achieved by contacting the coal-derived liquid containing suspended solids with an effective amount of an additive selected from the group of sulfuric acid, phosphoric acid, phosphoric anhydride and salts of sulfuric and phosphoric acid, and maintaining the contacted liquid at a temperature within the range of about 150-400°C and for a time sufficient to achieve the desired separation rate. Write: James E. Denny, Assistant General Counsel for Patents, Office of the General Counsel, U.S. Department of Energy, Washington, D.C. 20545, U.S.A.

**Hockey Checking Dummy**

**1,071,255/291**

**Mannequin d'exercice au hockey**

A checking dummy for use in hockey training. The dummy comprises a base with a framework extending outwardly from adjacent the edges of the base to simulate a crouched skater. Padding encases the framework. There are blades attached to the underside of the base so that the dummy can be pushed at a required speed on ice. The dummy permits training in hockey checking without risk of injury to the trainee. Write: John H. Hunter, 1187 Glenmore Street, Kelowna, B.C. V1Y 3E5, Canada

**Modular Building Structure****1,071,375/291****Éléments modulaires de construction**

In a modular wall and floor structure, the edges of wall panels have upwardly directed hooks projecting outwardly from their opposite vertical edges. Short lengths of multisided hollow extrusion have a downwardly opening longitudinal slot in each side which slots receive the panel hooks of adjacent panels for connecting such panels to form an exhibit array. Adjacent ends of overhead beams are connected to each other and to the upper ends of the panels by downwardly directed beam hooks received in upper longitudinal slots in the lengths of extrusion. The lower portions of the connected or unconnected panels can be clamped between modular floor components. Write: David C. Jensen, 1275 Nelson Street, Suite 302, Vancouver, B.C., Canada

**Process for Manufacturing Aluminum Fluoride****1,071,381/291****Procédé pour la fabrication de fluorure d'aluminium**

The process comprises contacting at 300 to 550°C particulate alumina hydrate with hydrogen fluoride to produce aluminum fluoride by continuously introducing a preheated particulate alumina hydrate into a reaction zone and continuously spraying at least stoichiometric amount of liquid hydrogen fluoride to the particulate alumina hydrate continuously fed and separating the resulting aluminum fluoride in the form of particles from gaseous substances. Write: Daikin Kogyo Kabushiki Kaisha, Shinhankyu Building, 8 Umeda, Kita-ku, Osaka-shi, Japan

**Loop Reactor for Chemical Processes****1,071,385/291****Boucle de réaction pour procédés chimiques**

The reactor includes a reactor housing including inlet means at one end and outlet means at the opposite end of the housing. Pipes are connected to the inlet means for supplying the reactants to be processed to the reactor. A guide tube is provided in the reactor housing defining a mixing chamber between the guide tube and the inner wall of the reactor housing. Write: Herwig Burgert, 2, Helgenstock, 6300 Giessen-Roedgen, West Germany

**Method for Dissolving Plutonium Dioxide****1,071,414/291****Dissolution du dioxyde de plutonium**

The fluoride-catalyzed, non-oxidative dissolution of plutonium dioxide in  $\text{HNO}_3$  is significantly enhanced in rate by oxidizing dissolved plutonium ions. It is believed that the oxidation of dissolved plutonium releases fluoride ions from a soluble plutonium-fluoride complex for further catalytic action. Write: James E. Denny, Assistant General Counsel for Patents, Office of the General Counsel, U.S. Department of Energy, Washington, D.C. 20545, U.S.A.

**Method for the Recovery of Halogens from Sodium****1,071,415/291****Récupération d'halogènes portés dans un flux de sodium**

Iodine and bromine are easily and quantitatively separated from the coolant of sodium-cooled reactors by passing a quantity of the sodium into a metal segregation vessel, and reducing the temperature of the vessel and coolant, whereupon the iodine and bromine segregates and adheres to the inner surface of the vessel where they remain after the coolant is separated from the vessel. This method is useful for establishing the absence or the presence and possible severity of a failed fuel element in the reactor. Write: James E. Denny, Assistant General Counsel for Patents, Office of the General Counsel, U.S. Department of Energy, Washington D.C. 20545, U.S.A.

**Pressure Sensor for High Temperature Liquids****1,071,426/291****Capteur de pression pour liquides haute température**

A pressure sensor for use in measuring pressures in liquid at high temperatures, especially such as liquid sodium or liquid potassium, comprises a soft diaphragm in contact with the liquid. The soft diaphragm is coupled mechanically to a stiff diaphragm. Pressure is measured by measuring the displacement of both diaphragms, typically by measuring the capacitance between the stiff diaphragm and a fixed plate when the stiff diaphragm is deflected in response to the measured pressure through mechanical coupling from the soft diaphragm. Absolute calibration is achieved by admitting gas under pressure to the region between diaphragms and to the region between the stiff diaphragm and the fixed plate, breaking the coupling between the soft and stiff diaphragms. The apparatus can be calibrated rapidly and absolutely. Write: James E. Denny, Assistant General Counsel for Patents, Office of the General Counsel, U.S. Department of Energy, Washington, D.C. 20545, U.S.A.

**Conveyer Track Apparatus for Logs****1,071,567/291****Transporteur de grumes**

A simple and efficient conveyer track apparatus for logs conveyed by an endless conveyer belt or chain and having stations for the rolling off of logs. Write: Kickons Svets Aktiebolag, Gardet, Acklinga 522 00 Tidaholm, Sweden

**Electrolytic Plating Method and Apparatus for Discrete Microsized Particles** 1,071,568/291

**Méthode et appareil de placage électrolytique de microparticules discrètes**

Method and apparatus are disclosed for electrolytically producing very uniform coatings of a desired material on discrete microsized particles. Agglomeration or bridging of the particles during the deposition process is prevented by imparting a sufficiently random motion to the particles that they are not in contact with a powered cathode for a time sufficient for such to occur. Write: James E. Denny, Assistant General Counsel for Patents, Office of the General Counsel, U.S. Department of Energy, Washington, D.C. 20545, U.S.A.

**Magnetic Separator with a Rotating Cylinder Between Opposing Magnetic Pole Faces** 1,071,583/291

**Séparateur magnétique à cylindre tournant entre les faces des pôles magnétiques**

A magnetic separator comprises a magnet and an iron cylinder rotatable in a gap in the magnet. The cylinder and the lower pole face of the magnet define a separator chamber. An aqueous suspension of magnetizable and non-magnetic particles is supplied to the separator chamber through channels extending through the magnet. Collection chambers are located at different levels on opposite sides of the rotatable cylinder. The cylinder rotates in a direction to move attracted magnetic material from a lower part of the separator chamber to the higher collector. Water jets can be used in removing the material. The separator may be applied to the wet separation of hematite,  $\text{Fe}_2\text{O}_3$ ; goethite,  $\text{FeOOH}$ ; fayalite,  $\text{Fe}_2\text{SiO}_4$ ; siderite,  $\text{FeCO}_3$ , and ilmenite,  $\text{FeTiO}_3$ . The invention features a pulp flow counter to the direction of the rotatable cylinder. Write: Mineral Processing Development & Innovation AB, Lagmansvagen 7, Gammelstod, Sweden

**Supporting Apparatus for Shelves or Other Objects** 1,071,608/291

**Support pour étagères ou autres objets**

The invention relates to apparatus adapted for attachment to a base structure to provide support for a shelf or the like. The apparatus according to the invention comprises a clip adapted, at least in part, to envelope the base structure. The apparatus according to the invention is such that the weight of the object being supported by the arm serves to maintain the apparatus in operative engagement with the base structure. Write: Guenther O. Zillt, 8404-136 Avenue, Edmonton, Alberta, T5E 1T8, Canada

**Electrically Operated Pet Door** 1,071,662/291

**Porte actionnée à l'électricité pour animal domestique**

This invention is an electrically powered animal door which can be installed in the external wall of a building. The door is operated electrically when a pet animal actuates the mechanism by means of a mechanical switch or light ray initiating device. The purpose is to permit a pet to enter or exit his owner's dwelling unassisted at his own discretion and at any time. The device is distinguishable from other inventions in that it is power operated, weather proof and selective. Write: Gordon A. Breakenridge, 3519-1st Street, N.W., Calgary, Alberta, T2K 0W7, Canada

**Control Circuit for Progressively Varying Illumination Intensity of Lamps** 1,071,699/291

**Gradateur de lumière**

The circuit comprises a source of alternating current connected in series with an electric lamp load which is also in series with a silicon controlled rectifier. This silicon control rectifier is rendered conductive when its gate is actuated by a gate signal generated by a programmable unijunction transistor (PUT). The conduction of the PUT depends on the voltage applied on its gate by a gate biasing circuit connected thereto and which comprises a charging capacitor. On the other hand, a charging circuit is connected across the silicon control rectifier whereas a second charging circuit is connected between the anode of the PUT and the first-mentioned charging circuit. Thus, progressive and gradual extinction or quenching as well as progressive and gradual ignition or lightening of the electric lamp are effected by making the charging or discharging time of the first-mentioned circuit higher than the charging or discharging time of the gate biasing circuit, whereby the time intervals between which the PUT is made conductive becomes longer and longer due to the reducing difference between the voltage supplied by the biasing circuit to the gate of the PUT and the voltage on the cathode of the PUT supplied by the second-mentioned charging circuit, at each source cycle. Write: Henry Delpy, 5920 Honoré Mercier, Montreal, Quebec, H1P 1C2, Canada

**Method of Preparing Porous Active Material for Use in Electrodes of Secondary Electrochemical Cells** 1,071,705/291

**Procédé de préparation d'un matériau actif et poreux pour les électrodes de piles électrochimiques**

Particles of carbonaceous matrices containing embedded electrode active material are prepared for vibratory loading within a porous electrically conductive substrate. In preparing the particles, active materials such as metal chalcogenides, solid

alloys of alkali or alkaline earth metals along with other metals and their oxides in powdered or particulate form are blended with a thermosetting resin and particles of a volatile to form a paste mixture. Write: James E. Denny, Assistant General Counsel for Patents, Office of the General Counsel, U.S. Department of Energy, Washington, D.C. 20545, U.S.A.

**Digital Switching Centre**

**1,071,742/291**

**Centre de commutation avec affichage**

A switching centre having a number of sets of buffer stores for connecting the channels of a number of pulse code modulated signal systems to the inputs of a multiplexer in which there is provided a unit for generating a false busy signal to prevent the reading of a buffer store at a time close to the time of writing into the store to reduce the possibility of simultaneous reading and writing and the consequent corruption of information. Write: Post Office, 23 Howland Street, London, W1P 6HQ, England

**Ramp to Load and Unload Vehicles into and from a Truck Body**

**1,071,811/291**

**Rampe pour embarquer des véhicules sur une plate-forme de camion, et les en débarquer**

A pair of longitudinally extended stringers include pins at the upper ends thereof to detachably engage apertures drilled in the open tail gate of the vehicle so that the stringers extend to the ground at approximately the same angle as the open tail gate. Cross members or rungs are secured in spaced and parallel relationship to cables, chains or the like and the lowermost cross member is bolted between the two stringers adjacent the lower ends thereof. When the stringers are secured by the upper ends into the apertures of the tail gate, the cross members are unrolled upwardly along the stringers and the uppermost cross member is then detachably secured to the stringers adjacent the upper ends thereof thus forming a ladder type ramp for the loading or unloading of a snowmobile. Also planks may be laid longitudinally between the stringers, for loading or unloading. The cross pieces are disconnected and the ramp unhooked for storing the ramps in the truck body. Write: Lucien Leduc, Box 368, Assiniboia, Saskatchewan, Canada

**Atomizing Nozzle Assembly for Making Metal Powder and Method**

**1,071,815/291**

**Tuyère d'atomisation pour la fabrication de poudre de métal, et méthode connexe**

A nozzle assembly for atomizing a stream of molten metal includes a refractory metal-transmitting nozzle having a short metering orifice at its entrance end and a relatively long divergent discharge passage terminating at a flat annular land formed at the bottom end of the metal-transmitting nozzle. Write: Carpenter Technology Corporation, 101 West Bern Street, Reading, Pennsylvania 19603, U.S.A.

**Process for Preparing Parts Made of Alkaline Beta Alumina**

**1,071,849/291**

**Procédé de préparation de pièces en aluminé bêta alcaline**

Procédé de fabrication de pièces en alumine bêta alcaline consistant à chauffer un mélange d'alumine et de carbonate de sodium, à broyer la poudre obtenue, à mettre les pièces en forme, à les fritter à 1650 °C, ces pièces étant disposées dans une enceinte de frittage apte à créer au voisinage des pièces une atmosphère riche en sodium. L'invention est mise en oeuvre dans la réalisation d'électrolyte pour générateurs sodium-soufre. Écrire: Compagnie Générale d'Électricité S.A., 54 rue la Boétie, 75382 Paris Cedex 08, France

**Bandsaw Mechanism**

**1,071,978/291**

**Mécanisme de régulation de la tension d'une scie à ruban**

A system for introducing "tensioning" stress distribution into the wide bandsaw blade without its plastic deformation, for automatically compensating for blade temperature expansions and blade position on the bandsaw wheels. Write: Thomas Bonac, 3636 West 30th Avenue, Vancouver, B.C. V6S 1W8, Canada

**Power Propelled Reciprocating Piston Pump Liquid Sprayer**

**1,072,064/291**

**Pulvérisateur motorisé à pompe alternative**

The apparatus has a reservoir which is mounted on a frame with wheels attached to cross members by which the reservoir with its contents is propelled forward. An electric or gas powered engine type, power unit is mounted on the reservoir which drives both the sprayer and the reciprocating piston pump mounted at the base of the reservoir. The pump employs a spring tensioned rubber piston with manual adjusting mechanism and is reciprocated by a power driven crank. On the induction stroke, liquid in the reservoir is drawn through the sliding disc valve into the cylinder. On compression, contents are forced through a spring ball loaded valve into a separate chamber situated within the reservoir. A tube runs from the chamber to the exterior of the reservoir where a flexible hose is attached with a spray nozzle on the end. A spring loaded release valve with

pressure adjustment and a faucet are situated on the chamber to permit any surplus fluid to be released back into the reservoir. The power to the rear wheels is transmitted via a "V" belt to a pulley attached to the crankshaft to which a sprocket is attached and from which power is further transmitted via a link chain, clutch and shaft arrangement, propelling the sprayer in the forward direction and reducing its speed to approximately walking pace. Write: Stevan Backo, 1884 Pilette Road, Windsor, Ontario, N8T 1P1, Canada

**Filtering Device for High Voltage Lines  
Used for Teletransmissions**

**1,072,190/291**

**Dispositif de filtrage pour lignes à haute  
tension utilisées comme support de télé-  
transmissions**

L'invention concerne le domaine des transmissions par courants porteurs HF sur lignes à haute tension. Dispositif de filtrage placé à une extrémité d'un tronçon de ligne d'un réseau électrique à haute tension dont les lignes sont utilisées, outre leur fonction de transport d'énergie, comme support pour des transmissions par courants porteurs à haute fréquence dans une gamme de fréquences. Les liaisons à haute fréquence sont établies d'un poste de sous-station à un poste de sous-station voisin. N bandes de fréquences sont allouées audit tronçon, appelé tronçon d'isolement, et aucune de ces n bandes de fréquences n'est utilisée dans les tronçons de lignes directement voisins. Écrire: CGEE Alsthom S.A., 13, rue Antonin Raynaud, 92309 Levallois Perret, France

**Method and Devices such as Projectors for  
Editing Sound Film**

**1,072,210/291**

**Méthode et dispositifs tels que projec-  
teurs pour montage de films sonores**

An apparatus in the form of a sound-viewer-editor or sound projector and a method are provided for facilitating the editing of a motion picture film bearing a longitudinally extending principal stripe on which a sound track is magnetically recorded, such sound track being longitudinally offset in a conventional manner relative to the scene images recorded on frames of the film which also bears a second or so-called balance stripe of magnetic material. Write: Bruce Anderson, 21 Crown Park Road, Toronto, Ontario, M4E 1J8, Canada

**Odor Neutralizer**

**1,072,254/291**

**Désodorisant**

Devices and processes, commonly used in controlling odors of human wastes in washrooms, are designed to attack the odor-carrying gasses in the air space of a room. In this invention the emphasis is set, instead, on preventing odors from spreading into the air space of a room by deodorizing these gasses at their source, i.e. the toilet bowl. To accomplish this, a number of electrical resistors are fastened on the bottom of a toilet seat, to provide the heat required for changing the composition of these highly unstable odor-carrying gasses, before allowing them to enter into the air space of a washroom. Write: Paul T. Himanen, 579 John Street, Thunder Bay, Ontario, P7B 1Y5, Canada

**Dye Transferring Method**

**1,072,259/291**

**Méthode de transfert de teinture**

For the transference of dyes from paper onto textile fabrics, using a heated press at a temperature between 80°C to 120°C at a pressure of up to 4.5 k per 6.5 cm<sup>2</sup>, and for a period not exceeding 10 minutes, whereafter the printed fabric or material is removed from the press, washed and dried, it is proposed to preliminarily treat the textile fabric with a padding material comprised of citric acid and/or potassium hydrogen sulphate and a printing paste thickener. Write: Fastran AG, Baarenstrasse 73, CH-6300, Zug 2, Switzerland

**Mooring Device**

**1,072,304/291**

**Dispositif d'amarrage**

A device for securing a line from a boat to a dock having spaced boards which permits ready engagement and disengagement of the line and dock. The device comprises a body having a shaft and an elongated head secured transversely to one end thereof. A plate is mounted on the shaft for slidable movement thereon towards and away from the head with its plane parallel to the head, to provide an adjustable but uniform space between corresponding points on confronting surfaces of the head and the plate. These surfaces, during operation of the device act to grip therebetween planking of the dock. A biasing means is associated with the shaft and plate to urge the plate towards the head as this space is increased from a minimum value. The device further comprises a means to which a line from the boat may be secured. This device greatly facilitates mooring a boat or the like to a dock or similar anchor structure in that the device, to which a line from the boat has been attached, need merely have its head passed longitudinally between adjacent, spaced boards of the dock against the urging of the biasing means, and its body then rotated so that its head is transversely located with respect to that space. The device thereby grips between the confronting surfaces of the head and plate of these boards of the dock. Write: Keith I. Beacom, Box 178, Huntsville, Ontario, P0A 1K0, Canada

**Process for Bonding Two Parts Made  
Respectively of Alcaline Beta Alumina  
and Alpha Alumina**

**1,072,307/291**

**Procédé de liaison entre pièces en alumine  
beta alcaline et en alumine alpha**

Procédé de liaison entre pièces en alumine alpha et en alumine bêta consistant à chauffer de 1400°C à 1600°C pendant 10 à 20 heures la pièce d'alumine alpha au sein d'une masse de carbonate alcalin, puis à disposer en contact mutuel ladite pièce d'alumine alpha avec une ébauche de la pièce d'alumine et cela dans une enceinte de frittage apte à créer une atmosphère riche en métal alcalin, puis à chauffer cette enceinte à 1600 1700°C pendant 30 minutes à 4 heures de sorte à fritter la pièce en alumine bêta alcaline tout en réalisant sa liaison avec la pièce d'alumine alpha. L'invention est mise en oeuvre dans les générateurs électrochimiques du type sodium-soufre. Écrire: Compagnie Générale d'Electricité S.A., 54, rue La Boétie, 75382 Paris Cedex 08, France

**Bidentate Organophosphorus Solvent  
Extraction Process for Actinide Recovery  
and Partition**

**1,072,341/291**

**Procédé d'extraction par un solvant  
d'organophosphore bidenté pour la  
récupération et le partage des actinides**

A liquid-liquid extraction process for the recovery and partitioning of actinide values from acidic nuclear waste aqueous solutions, the actinide values including trivalent, tetravalent and hexavalent oxidation states is provided and includes the steps of contacting the aqueous solution with a bidentate organophosphorus extractant to extract essentially all of the actinide values into the organic phase. Thereafter the respective actinide fractions are selectively partitioned into separate aqueous solutions by contact with dilute nitric or nitric-hydrofluoric acid solutions. The hexavalent uranium is finally removed from the organic phase by contact with a dilute sodium carbonate solution. Write: James E. Denny, Assistant General Counsel for Patents, Office of the General Counsel, U.S. Department of Energy, Washington, D.C. 20545, U.S.A.

**Process and Device for Suspension Smelting  
of Finely-Divided Sulfidic and/or Oxidic  
Ores or Concentrates**

**1,072,343/291**

**Processus et dispositif pour l'affinage  
en suspension de concentrés de parti-  
cules fines de minerais de type sulfure  
ou de type oxyde**

A process in which suspension of the finely-divided raw material in an oxygen containing gas is directed downwards as a suspension in a reaction zone formed jointly by the suspension and a melt below it, in order to oxidize and partially melt the raw material in suspension, whereafter the suspension flow is caused to change its flow direction perpendicularly sideways so that most of the raw material particles present in the suspension flow impinge against the surface of the accumulated melt in the lower part of the suspension reaction zone, and the remaining suspension flow is directed into a rising-flow zone, and the solids are separated. In order to improve the energy economy of the suspension smelting and to increase the capacity, the temperature of the particles falling downwards in the suspension reaction zone is regulated so that the change in the heat content of the particles impinging against the melt covers the heat quantity required by the endothermal reactions occurring in the melt and together with the change in the heat content of the gas replaces the thermal losses of the furnace. Write: Outokumpu Oy, Outokumpu, Finland

**Fluidic Mill**

**1,072,514/291**

**Broyeur en milieu fluide**

A mill for pumping and grinding solid particles in a fluid medium. The particles are circulated by centrifugal forces that result from rotational movement imparted to freely rolling balls or rollers about a powered circular race assembly. Write: Verle W. Woods and Jay A. Woods, c/o Woods Industries, Inc., P.O. Box 1016, Yakima, Washington 98907, U.S.A.

**Lightweight Concrete Material**

**1,072,585/291**

**Matériau léger en béton**

A mixture of Silica Flour, Silica Sand and Hydrated Lime together with Portland Cement or the equivalent is mixed with water and various dry components are added while the lime is slaking. Such dry components may include a detergent for ease of water penetration and a gelling agent to increase the gelling action. The resultant slurry foams and expands within a mould or tray at which time it is steam treated by means of an autoclave or the like to cure the resultant product which is easily cut, drilled and handled and is lightweight with good structural and insulating and fire-proof properties. Write: William L. Jackman, 1323-21st Avenue, N.W., Calgary, Alberta, Canada

**Charging System and Method for Multicell  
Storage Batteries**

**1,072,631/291**

**Système et procédé de chargement  
pour accumulateur à plusieurs  
éléments**

A battery-charging system having a first charging circuit connected in series with a number of battery cells for controlled current charging. A second charging circuit applies a controlled voltage across each individual cell for equalization of the cells to the fully charged condition. This controlled voltage is determined at a level above the fully charged open-circuit

voltage but at a sufficiently low level to prevent corrosion of cell components by electrochemical reaction. In this second circuit for cell equalization, a transformer primary receives closely regulated, square-wave voltage which is coupled to a number of equal secondary coil windings. Each secondary winding is connected in parallel to each cell of a series-connected pair of cells through half-wave rectifiers and a shared, intermediate conductor. Write: James E. Denny, Assistant General Counsel for Patents, Office of the General Counsel, U.S. Department of Energy, Washington, D.C. 20545, U.S.A.

**Decorative Stereo Speaker**

**1,072,712/291**

**Haut-parleur décoratif de chaînes stéréo**

A decorative enclosure and a method for making such enclosure is disclosed in which a face mask of a person is made by applying a liquid material to the face, the material hardening at body temperature after which a casting is made from the hardened material. A hollow base is positioned in the casting before it is set and a sound speaker is mounted in the frame. A plastic coating is applied to the casting, the coating once hardened being painted in colors to duplicate the face on which the film was cast. In this manner, a personalized hi-fidelity speaker enclosure may be obtained. Write: Peter McCarthy, 111 Blackfriar Avenue, Apt. 216, Weston, Ontario, Canada

**Apparatus and Process for Making Yogourt**

**1,072,897/291**

**Procédé et appareil pour faire le yogourt**

Dans la présente invention, on utilise un procédé et un appareil pour faire du yogourt, spécialement pour l'usage domestique, dont l'incubation est réalisée à une température de 44° C (112° F), en contrôlant les fluctuations de ladite température dans un intervalle serré d'environ  $\pm .27^{\circ}\text{C}$  ( $\pm 0.5^{\circ}\text{F}$ ). L'appareil conçu pour réaliser cette incubation comprend un ensemble corps de base-corps intérieur, dans lequel est placé un contenant pour le lait /yogourt. Entre le corps intérieur et ledit contenant, on trouve un liquide, de préférence de l'eau. Un ensemble de chauffage, placé sur le corps intérieur comprend une feuille métallique sur la surface extérieure dudit corps, feuille sur laquelle sont appliqués des moyens chauffants électriques et un limiteur de température, les deux derniers étant recouverts par une autre feuille métallique. Un ensemble de chauffage est relié à des moyens électroniques de régulations qui assurent une température optimale d'incubation du lait. Ces moyens comprennent un détecteur de température et un élément de contrôle, le dernier ayant un temps de réponse très court, qui assure un contrôle très précis de la température,  $\pm .27^{\circ}\text{C}$  ( $\pm 0.5^{\circ}\text{F}$ ). Un couvercle ferme l'ensemble corps de base-corps intérieur. Écrire: Roland St-Pierre, 2334, boul. Marie-Victorin, Varennes, Québec, Canada; Jean-Claude Fortin, 245, boul. Hymus, C.P. 570, Pte-Claire-Dorval, Pointe-Claire, Québec H96 4S6, Canada; Jacques Roy, 333, rue Franquet, Ste-Foy, C.P. 9038, Ste-Foy, Québec, G1V 4C7, Canada

**Coal Liquefaction Process**

**1,072,898/291**

**Procédé de liquéfaction du charbon**

An improved coal liquefaction process is provided which enables conversion of a coal-oil slurry to a synthetic crude refinable to produce larger yields of gasoline and diesel oil. The process is characterized by a two-step operation applied to the slurry prior to catalytic desulfurization and hydrogenation in which the slurry undergoes partial hydrogenation to crack and hydrogenate asphaltenes and the partially hydrogenated slurry is filtered to remove minerals prior to subsequent catalytic hydrogenation. Write: James E. Denny, Assistant General Counsel for Patents, Office of the General Counsel, U.S. Department of Energy, Washington, D.C. 20545, U.S.A.

**Device for Providing High-Intensity Ion or Electron Beam**

**1,072,913/291**

**Générateur de faisceaux d'ions ou d'électrons de grande intensité**

A thin film of a low-thermionic-work-function material is maintained on the cathode of a device for producing a high-current, low-pressure gas discharge by means of sputter deposition from an auxiliary electrode. The auxiliary electrode includes a surface with a low-work-function material, such as thorium, uranium, plutonium or one of the rare earth elements, facing the cathode but at a disposition and electrical potential so as to extract ions from the gas discharge and sputter the low-work-function material onto the cathode. By continuously replenishing the cathode film, high thermionic emissions and ion plasmas can be realized and maintained over extended operating periods. Write: James E. Denny, Assistant General Counsel for Patents, Office of the General Counsel, U.S. Department of Energy, Washington, D.C. 20545, U.S.A.

**Adjustable Ladder Support**

**1,072,926/291**

**Support réglable d'échelle**

A ladder support for imparting lateral stability to a ladder includes a C-shaped channel member for each side leg of the ladder. The ladder is held by the support assemblies against any lateral forces which might tend to otherwise tip the ladder. When not in use the shoe members are compactly stored within their corresponding channel members. Write: George R. Mair, 3236 Harwood Blvd., Vaudreuil, Québec, Canada

**Transport Apparatus with Differential Force System** 1,072,993/291

**Transporteur doté d'un système de tension différentielle**

Tape apparatus in which a length of pliant material is fed between supply and take-up rolls in edge driven relationship with a capstan. A static force provided, for example by friction or a spring is utilized to maintain the take-up roll against the capstan with a greater force than the supply roll, and in the event of a reversal of tape direction. This force is immediately and automatically applied to the new take-up roll and removed from the new supply roll. Write: American Videonetics Corporation, 432 Toyama Drive, Sunnyvale, California 94096, U.S.A.

**Auxiliary Rider Support for Jog Carts** 1,072,999/291

**Siège auxiliaire pour charrette anglaise**

Device incorporates an upper adjustable hook engageable over a jog cart shaft and a lower locking member threadedly engageable with the projecting end of the adjacent cart wheel axle. A stabilizing member between the locking member and the hook cooperates with both to enable a fixing of the support to the jog cart. The support includes a seat fixed to and overlying the hook and a footrest and guard assembly spaced therebelow. Write: Joseph Zitone, R.F.D. 1, Port Jervis, New York 12771, U.S.A.

**Magnetohydrodynamic Electrode** 1,073,029/291

**Électrode pour génératrice magnétohydrodynamique**

A ceramic-metal composite suitable for use in a high-temperature environment consists of a refractory ceramic matrix containing 10 to 50 volume percent of a continuous high-temperature metal reinforcement. In a specific application of the composite, as an electrode in a magnetohydrodynamic generator, the one surface of the electrode which contacts the MHD fluid may have a layer of varying thickness of nonreinforced refractory ceramic for electrode temperature control. Write: James E. Denny, Assistant General Counsel for Patents, Office of the General Counsel, U.S. Department of Energy, Washington, D.C. 20545, U.S.A.

**Cathode for Molten Salt Batteries** 1,073,043/291

**Cathode pour piles à base de sels fondus**

A molten salt electrochemical system for battery applications comprises tetravalent sulfur as the active cathode material with a molten chloroaluminate solvent comprising a mixture of  $AlCl_3$  and  $MCl$  having a molar ratio of  $AlCl_3/MCl$  from greater than 50.0/50.0 to 80/20. Write: James E. Denny, Assistant General Counsel for Patents, Office of the General Counsel, U.S. Department of Energy, Washington, D.C. 20545, U.S.A.

**Time Base Error Corrector** 1,073,096/291

**Correcteur d'erreur de base de temps**

A time base error corrector for correcting time base errors in recurrent information such as horizontal lines of a video signal by random selection of a delay line tap is disclosed. Incoming recurrent information groups are converted into impulse trains, in which the information is carried on the leading edges of the impulses, which are passed asynchronously through a delay line of plural cascaded digital gates having propagation delays which provide known tapped increments of delay as well as providing regeneration of each impulse passing therethrough. A digital counter is clocked at a rate corresponding to said delay increments and counts the time base error of a train as it counts down the taps of said line. The total reached in counting the time base error determines the tap through which the impulse train is output from the delay line. A restoration circuit then restores the original signal format to the corrected information group. Write: American Videonetics Corporation, 432 Toyama Drive, Sunnyvale, California 94806, U.S.A.

**Negative Impedance Repeater for Telephone Line** 1,073,137/291

**Répéteur à impédance négative pour ligne téléphonique**

A negative impedance repeater for amplification in telephone lines operating at voice frequency comprises two converters, one of them stable with open terminals and the other stable with short-circuited terminals; each converter is loaded by a fixed network of passive impedances chosen according to the characteristic impedance of the line to be amplified, and provided with means, external to the network of passive impedances, for adjusting the feedback, and consequently the conversion ratio. The conversion ratios of the two converters may be varied independently from each other so that in the case of loaded lines their product may be kept always constant and this allows to adjust the repeater gain without modifying its impedance, while for unloaded lines it is possible to obtain that such product increases with a certain law by increasing gain, and this fact causes an equalization at the highest frequencies of the band, which is necessary for this type of lines. Write: Applicazioni Elettrotelefoniche A.E.T. S.p.A., Via Gianfrancesco Re, 47-Turin, Italy

PAPER OR MICROFICHE COPIES OF THE FOLLOWING UNITED STATES PATENT APPLICATIONS THAT ARE AVAILABLE FOR U.S. AND POSSIBLY FOREIGN LICENSING MAY BE OBTAINED FROM NTIS, 5285 PORT ROYAL ROAD, SPRINGFIELD, VIRGINIA, 22161 BY USING VISA, MASTER CHARGE, AMERICAN EXPRESS, NTIS DEPOSIT ACCOUNTS, CHEQUE OR MONEY ORDER IN \$U.S. AT THE PRICES INDICATED.

ON PEUT SE PROCURER, AUX PRIX INDICUÉS, DES COPIES, SUR PAPIER OU MICROFICHE, DES DEMANDES AMÉRICAINES DE BREVETS CI-APRÈS POUVANT FAIRE L'OBJET D'UN OCTROI DE LICENCE AUX ÉTATS-UNIS ET PEUT-ÊTRE À L'ÉTRANGER, EN S'ADRESSANT AU NTIS, 5285 PORT ROYAL ROAD, SPRINGFIELD (VIRGINIE) 22161 À L'AIDE DES CARTES VISA, MASTER CHARGE, AMERICAN EXPRESS, D'UN COMPTE DE DÉPÔT NTIS OU D'UN CHÈQUE OU MANDAT POSTAL EN DEVICES AMÉRICAINES.

**Rotating Field Plot Row Marker**

**PAT-APPL-6-043976/291 Marqueur rotatifs de rangs**

Filed 30 May 79, PB80-114804. Department of Agriculture. This invention relates to an agricultural row marking apparatus of the type that makes impressions in the earth to assist in the placement of seeds or seedlings during planting. It is equipped with both traverse and longitudinal imprinting projections which impresses a grid-type pattern into the soil for precise placement of seeds or seedlings in a subsequent planting operation. Price: PC U.S. \$5.00/MF U.S. \$3.50. Write: Mr. George Kudravetz, Product Manager, NTIS, United States Department of Commerce, 5285 Port Royal Road, Springfield, Virginia 22161 and send a copy of your initial correspondence to Canadian Consulate, 3 Parkway Building, Suite 1310, Philadelphia, Pennsylvania 19102.

**Iron Rod Technique for Measuring Surface Soil Watertables**

**PAT-APPL-6-052 657/291 Technique de la tige de fer pour mesurer le niveau de la nappe phréatique dans les sols superficiels**

Filed 27 Jun 79, PB80-114796. Department of Agriculture. The invention relates to a method for determining average soil water levels during wet seasons. The method involves inserting clean mild steel rods in the soil and measuring the depth of rust on the rods after 8 to 16 weeks. Mild steel rods rust rapidly in aerated soil above the water table but remain free of rust below the soil water table where air is excluded. This technique appears to work well on imperfectly and poorly drained soils. Price: PC U.S. \$5.00/MF U.S. \$3.50. Write: Mr. George Kudravetz, Product Manager, NTIS, United States Department of Commerce, 5285 Port Royal Road, Springfield, Virginia 22161 and send a copy of your initial correspondence to Canadian Consulate, 3 Parkway Building, Suite 1310, Philadelphia, Pennsylvania 19102.

**Cyclone Dust Analyzer for Determining Microdust Content in Fibers**

**PAT-APPL-6-053 476/291 Analyseur de poussière cyclone pour déterminer la teneur des fibres en micropoussières**

Filed 29 Jun 79, PB80-101017. Department of Agriculture. A means of analyzing the microdust in cotton which causes lung disorders and diseases has become an important field of research in the textile industry. An apparatus for removing dust from a fiber sample for subsequent analysis is disclosed. A first upper cylindrical chamber containing a fiber sample has a tangential air jet and a radial air jet installed to swirl and tumble the fiber sample in a cyclonic fashion, thus liberating the dust from the sample when either a positive or a negative pressure is applied through the air jets. The liberated dust particles are then screened out through a 100 mesh screen filter and exhausted through a funnel. The device can be equipped with a second stage chamber containing a plurality of stepstage filters and a third stage plurality of microfilters to selectively screen the dust particles. A blow bottle containing an aqueous medium to absorb even the finest dust particles or gas can also be added as a fourth stage. Price: PC U.S. \$5.00/MF U.S. \$3.50. Write: Mr. George Kudravetz, Product Manager, NTIS, United States Department of Commerce, 5285 Port Royal Road, Springfield, Virginia 22161 and send a copy of your initial correspondence to Canadian Consulate, 3 Parkway Building, Suite 1310, Philadelphia, Pennsylvania 19102.

**Novel Aroid Products**

**PAT-APPL-6-055 116/291 Nouveaux produits d'aracées**

Filed 5 Jun 79, PB80-114812. Department of Agriculture. This invention relates to and has among its objects novel products from Aroids (family Aracae) and novel methods of making the same. Novel products are prepared from Aroid corms by first peeling and washing the corms and then cutting the corms into pieces. Aqueous alkali is applied to the corms to remove acid principles and then the corms are treated with aqueous hydrogen peroxide to prevent discoloration. The so-treated corms are washed with water until they are neutral and then dried. Price: PC U.S. \$5.00/MF U.S. \$3.50. Write: Mr. George Kudravetz, Product Manager, NTIS, United States Department of Commerce, 5285 Port Royal Road, Springfield, Virginia 22161 and send a copy of your initial correspondence to Canadian Consulate, 3 Parkway Building, Suite 1310, Philadelphia, Pennsylvania 19102.

**Shrinkproofing Wool with Copper Salts of Carboxylic Acids**

**PAT-APPL-6-057 858/291 Traitement antirétrécissement de la laine avec des sels de cuivre d'acides carboxyliques**

Filed 16 Jul 79, PB80-114820. Department of Agriculture. Proteinaceous fibers are modified by first contacting the fibers with an aqueous solution of a cupric salt of a carboxylic acid containing from 2-18 carbon atoms, and then contacting the so-treated fibers with a hot, semipolar, water-miscible organic solvent. The modified fibers exhibit increased resistance to shrinkage. Price: PC U.S. \$5.00/MF U.S. \$3.50. Write: Mr. George Kudravetz, Product Manager, NTIS, United States Department of Commerce, 5285 Port Royal Road, Springfield, Virginia 22161 and send a copy of your initial correspondence to Canadian Consulate, 3 Parkway Building, Suite 1310, Philadelphia, Pennsylvania 19102.

**Foam Flotation Process for Separating 'Bacillus thuringiensis' Sporulation Products**

**PAT-APPL-6-064 678/291 Procédé de flottation par une mousse pour séparer les produits de sporulation de "Bacillus thuringiensis"**

Filed 8 Aug 79, PB80-114788. Department of Agriculture. Crystal-enriched suspensions are derived from sporulated cultures of *Bacillus thuringiensis* by a foam flotation process in which added gelatin causes the spores to be selectively entrained in the foam and thereby separated from the suspensions. Price: PC U.S. \$5.00/MF U.S. \$3.50. Write: Mr. George Kudravetz, Product Manager, NTIS, United States Department of Commerce, 5285 Port Royal Road, Springfield, Virginia 22161 and send a copy of your initial correspondence to Canadian Consulate, 3 Parkway Building, Suite 1310, Philadelphia, Pennsylvania 19102.

**Near Millimeter Wavelength Modulator and Tunable Oscillator**

**PAT-APPL-6-023 371/291 Modulateur et oscillateur réglable pour les ondes quasi millimétriques**

Filed 23 Mar 79, AD-D006 469/1. Department of the Air Force. This document discloses a modulator and tunable oscillator capable of reliable operation in the near millimeter wavelength region. The modulator is made up of a pair of reflectors and a beamsplitter interposed therebetween with one of the reflectors having variable reflectivity. In addition, the reflectors are spaced apart a preselected distance such that a resonant condition is achieved with respect to an incoming beam of near millimeter wavelength radiation. By applying a signal to the variable reflector a beam of radiant energy is generated at a wavelength at which a non-resonant condition is achieved between the reflectors. This generated beam of radiation is directed out of the modulator by the beamsplitter. The oscillator utilizes the same elements as the modulator and in addition incorporates therein an additional beam splitter and a detector as well as a feedback circuit between the detector and variable reflector. Price: PC U.S. \$5.00/MF U.S. \$3.50. Write: Mr. George Kudravetz, Product Manager, NTIS, United States Department of Commerce, 5285 Port Royal Road, Springfield, Virginia 22161 and send a copy of your initial correspondence to Canadian Consulate, 3 Parkway Building, Suite 1310, Philadelphia, Pennsylvania 19102.

**Electro-Dynamic Laser with Acoustic Absorbing Electrode**

**PAT-APPL-6-046 073/291 Laser électrodynamique à électrode d'absorption acoustique**

Filed 6 Jun 79, AD-D006 471/7. Department of the Air Force. This document discloses a high pressure, high power, continuous wave electrodynamic laser having one of the electrodes (preferably the cathode) made of a porous conductive surface and a backing material capable of broad band acoustic absorption. Such an arrangement effectively absorbs acoustic disturbances which arises primarily from a linear instability within the resonant cavity of the electrodynamic laser and thereby substantially reduces output flux modulations within the resonant cavity. Price: PC U.S. \$5.00/MF U.S. \$3.50. Write: Mr. George Kudravetz, Product Manager, NTIS, United States Department of Commerce, 5285 Port Royal Road, Springfield, Virginia 22161 and send a copy of your initial correspondence to Canadian Consulate, 3 Parkway Building, Suite 1310, Philadelphia, Pennsylvania 19102.

**Oxide Passivated Mesa Epitaxial Diodes with Integral Plated Heat Sink**

**PAT-APPL-6-050 272/291 Diodes mesaépitaxiaux rendus passifs à l'oxide avec cuve à chaleur plaquée intégrée**

Filed 19 Jun 79, AD-D006 305/7. Department of the Air Force. The present invention is directed to a semiconductor device and a method by which the device may be fabricated. The device comprises an oxide passivated mesa epitaxial diode with an integral heat sink and is fabricated in such a manner that the junction is passivated by the thermal growth of an oxide layer over the junction region without causing a reaction between the contact metals and the surrounding environment. In one form, the diode takes the shape of a mesa upon a supporting structure of thermally conductive metal, the latter serving both as an electrical contact and thermal heat sink. Directly upon the metallic base is the first semiconductor layer of the mesa, a heavily doped material of the first conductivity type. Covering the latter layer of the mesa is a layer of lightly doped material of the second conductivity type, opposite that of the first, forming therebetween a pn junction. Upon the lightly doped layer is a heavily doped layer of the same conductivity type, which is covered, at the mesa top, by a metallic contact. The side walls of the mesa structure, particularly in the region of the pn junction, are covered by a layer of highly pure SiO<sub>2</sub> material. The

resultant device has low thermal and electrical resistance without sacrificing the quality of the surface passivation at the pn junction. Price: PC U.S. \$5.00/MF U.S. \$3.50. Write: Mr. George Kudravetz, Product Manager, NTIS, United States Department of Commerce, 5285 Port Royal Road, Springfield, Virginia 22161 and send a copy of your initial correspondence to Canadian Consulate, 3 Parkway Building, Suite 1310, Philadelphia, Pennsylvania 19102.

**Stepped-Rod Ferrite Microwave Limiter PAT-APPL-6-055-425/291 Limiteur micro-ondes à tige de ferrite  
Having Wide Dynamic Range and Optimal Frequency Selectivity** **étagée, caractérisé par une large gamme  
dynamique et une sélectivité optimale**

Filed 6 Jul 79, AD-D006 473/3. Department of the Air Force. A stepped-diameter ferrite rod having dielectric resonant disks of varying size and electric constant, provides a frequency-selective limiter which has wide instantaneous bandwidth, subsidiary resonance mode biasing for low threshold, sharp frequency selectivity above threshold and wide dynamic range. Price: PC U.S. \$5.00/MF U.S. \$3.50. Write: Mr. George Kudravetz, Product Manager, NTIS, United States Department of Commerce, 5285 Port Royal Road, Springfield, Virginia 22161 and send a copy of your initial correspondence to Canadian Consulate, 3 Parkway Building, Suite 1310, Philadelphia, Pennsylvania 19102.

**Method and Apparatus for Temperature Data Acquisition PAT-APPL-6-058 335/291 Méthode et appareil d'acquisition de  
données sur la température**

Filed 17 Jul 79, AD-D006 474/1. Department of the Air Force. According to this invention a method and apparatus are provided for obtaining data to determine transient thermal properties of transparent materials. Use is made of a Schlieren Moire technique to obtain fringe patterns. The samples are irradiated with a carbon dioxide laser beam with a shutter mechanism provided to permit accurate control of the irradiation time. Price: PC U.S. \$5.00/MF U.S. \$3.50. Write: Mr. George Kudravetz, Product Manager, NTIS, United States Department of Commerce, 5285 Port Royal Road, Springfield, Virginia 22161 and send a copy of your initial correspondence to Canadian Consulate, 3 Parkway Building, Suite 1310, Philadelphia, Pennsylvania 19102.

**Method of Fabricating Cadmium Electrodes PAT-APPL-6-061 558/291 Méthode de fabrication d'électrodes de  
cadmium**

Filed 27 Jul 79, AD-D006 476/6. Department of the Air Force. The invention provides a method of fabricating porous cadmium electrodes that have a high cadmium loading without surface buildup, also cleaning of the cadmium counter electrodes is eliminated and the previously required formation step is no longer necessary. Price: PC U.S. \$5.00/MF U.S. \$3.50. Write: Mr. George Kudravetz, Product Manager, NTIS, United States Department of Commerce, 5285 Port Royal Road, Springfield, Virginia 22161 and send a copy of your initial correspondence to Canadian Consulate, 3 Parkway Building, Suite 1310, Philadelphia, Pennsylvania 19102.

**Method and Apparatus for Testing Crystal Elements PAT-APPL-870 694/291 Méthode et appareil d'essai de quartz**

Filed 19 Jan 78, AD-D006 417/0. Department of the Army. A method and apparatus are described for determining anomalies in the frequency- or admittance-temperature characteristics of a piezoelectric crystal resonator by inserting a variance capacitance network in series with the crystal and electronically sweeping the value of the capacitance network by a control voltage applied thereto while the temperature remains constant and noting any abrupt change in the resonance frequency characteristics. Price: PC U.S. \$5.00/MF U.S. \$3.50. Write: Mr. George Kudravetz, Product Manager, NTIS, United States Department of Commerce, 5285 Port Royal Road, Springfield, Virginia 22161 and send a copy of your initial correspondence to Canadian Consulate, 3 Parkway Building, Suite 1310, Philadelphia, Pennsylvania 19102.

**Control Rod Roll-Over Limiter PAT-APPL-927 704/291 Limiteur de course de biellettes**

Filed 24 Jul 78, AD-D006 495/6. Department of the Army. A stop device limits rods, such as control rods, used in helicopter flight control systems, from roll-over in selected directions, while allowing substantially unrestricted motion in other directions. This invention provides a means for limiting undesired roll-over of control rods of the type having an aperture through the rod end with an annular perimeter in which is secured a self-aligning bearing. The bearing is in the form of a ball having a shaft therethrough locked in a race in the aperture. The roll-over stop means includes a boss member positioned on the portion of the rod end that forms the perimeter of the aperture. The boss member is adapted for abutment with a clevis to which the rod end is attached. This limits roll-over movement. It will, however, permit unrestricted motion and misalignment in selected directions. The stop means meeting the foregoing objectives will not lead to derogation of the strength of the bearing as the boss wears. Price: PC U.S. \$5.00/MF U.S. \$3.50. Write: Mr. George Kudravetz, Product Manager, NTIS, United States Department of Commerce, 5285 Port Royal Road, Springfield, Virginia 22161 and send a copy of your initial correspondence to Canadian Consulate, 3 Parkway Building, Suite 1310, Philadelphia, Pennsylvania 19102.

**Phase Measurement Device****PAT-APPL-937 244/291 Dispositif de mesurage de phase**

Filed 28 Aug 78, AD-D006 416/2. Department of the Army. This document describes a device for testing phase inversion of a circuit includes a signal generator having an assymmetrically shaped positive phased test signal output electrically connected through a buffer circuit to the input of the circuit under test. A differentiator circuit electrically connected to the output of the test circuits, produces in response to the test circuit output, rectangular pulses whose amplitudes are proportional to the slopes of the test waveform. The differentiated output signals are isolated into positive and negative signals by a plurality of peak detectors whose outputs are fed to a summing amplifier. The summing amplifier amplifies the difference between the positive and negative isolated peak voltages and in turn drives a polarity indicating device which was previously calibrated to indicate a positive or negative polarity as either a phase or non-phase inversion. An alternate mode of measuring pulses directly and bypassing the differentiator is also provided. Price: PC U.S. \$5.00/MF U.S. \$3.50. Write: Mr. George Kudravetz, Product Manager, NTIS, United States Department of Commerce, 5285 Port Royal Road, Springfield, Virginia 22161 and send a copy of your initial correspondence to Canadian Consulate, 3 Parkway Building, Suite 1310, Philadelphia, Pennsylvania 19102.

**Rotor Blade Root End Attachment and Method of Manufacture****PAT-APPL-948 718/291 Description et méthode de fabrication de la base d'une pale de rotor**

Filed 5 Oct 78, AD-D006 497/2. Department of the Army. A helicopter spar root end and blade assembly for attachment to the rotary head of the helicopter, the spar includes the root end attachment having a series of formed apertures therein generally molded from strips of fiber reinforced tapes, and which tapes are turned from their disposition at the aperture for extension outboard of the blade to enhance its structural reinforcement against fatigue and fracture. The method for forming such a spar root end and blade assembly includes the disposition of a removable form for positioning of the resin treated tapes along the intended length of the spar root and blade, simultaneously positioning fiberglass sheets into the configuration of the intended blade assembly, and then compressing die halves into position around the tape and sheet formed assembly at a pressure and temperature for a stipulated period of time until the molded assembly and its inherent resin achieves curing and setting into its final and concise form. Price: PC U.S. \$5.00/MF U.S. \$3.50. Write: Mr. George Kudravetz, Product Manager, NTIS, United States Department of Commerce, 5285 Port Royal Road, Springfield, Virginia 22161 and send a copy of your initial correspondence to Canadian Consulate, 3 Parkway Building, Suite 1310, Philadelphia, Pennsylvania 19102.

**Copolymers of Alpha-N-Alkylstyrenes and Styrene****PAT-APPL-952 873/291 Copolymères d'alpha-N-alkylstyrènes et du styrène**

Filed 19 Oct 78, AD-D006 418/8. Department of the Army. This invention relates to novel copolymers of styrene and alpha-n-alkylstyrenes containing at least eleven carbon atoms in the alkyl group. Those copolymers of the invention which contain at least 20 mole percent of the alpha-n-alkylstyrenes are solids and have greater durability with lower coefficients of friction than a comparable styrene homopolymer. The copolymers of this invention can be produced by an anionic initiated copolymerization using metallic sodium as a catalyst or by a radical initiated copolymerization using benzoyl peroxide or azobisisobutyronitrile (AIBN) as the catalyst. Price: PC U.S. \$5.00/MF U.S. \$3.50. Write: Mr. George Kudravetz, Product Manager, NTIS, United States Department of Commerce, 5285 Port Royal Road, Springfield, Virginia 22161 and send a copy of your initial correspondence to Canadian Consulate, 3 Parkway Building, Suite 1310, Philadelphia, Pennsylvania 19102.

**Electronic Velocimeter****PAT-APPL-959 542/291 Vélocimètre électronique**

Filed 13 Nov 78, AD-D006 419/6. Department of the Army. An electronic velocimeter for measuring the muzzle velocity of a projectile employs a conductive coil mounted between the muzzle and an annular conductive shield. The shield and coil are insulated from each other and encircle the trajectory of the projectile. An oscillator means for generating an oscillator signal is coupled to the coil. This oscillator means is responsive to the projectile passing through the coil. A timing means responds to the oscillator to produce a timing signal. This timing signal represents the transit time for the projectile to traverse a pre-determined interval of the trajectory of the projectile. Knowing this transit time the velocity is readily obtained. Price: PC U.S. \$5.00/MF U.S. \$3.50. Write: Mr. George Kudravetz, Product Manager, NTIS, United States Department of Commerce, 5285 Port Royal Road, Springfield, Virginia 22161 and send a copy of your initial correspondence to Canadian Consulate, 3 Parkway Building, Suite 1310, Philadelphia, Pennsylvania 19102.

**Non-Spill Gas-Liquid Contact Unit****PAT-APPL-965 955/291 Pièce de contact gaz-liquide antifuite**

Filed 4 Dec 78, AD-D006 420/4. Department of the Army. A non-spill gas-liquid contact unit for use in a portable detector device for testing the atmosphere for the presence of hazardous substances. The gas-liquid contact unit includes a tubular chamber for absorber liquid, surmounted by a tubular air chamber removably attached thereto by a fluid tight joint, and a breather tube for drawing environmental air through the absorber liquid. The air chamber possesses an axial gas inlet tube projecting from its lower end for admitting gas from the absorber chamber, and an axial gas outlet tube whose one end pro-

jects into the upper end of the air chamber and the other end can be connected to a vacuum pump. The air chamber with its inlet and outlet tubes functions as a lock so that, when the unit is accidentally tilted from the normally vertical position to a horizontal or an inverted position while it is under vacuum, the liquid cannot spill out of the unit and thus nullify the analysis and corrode the vacuum pump. Price: PC U.S. \$5.00/MF U.S. \$3.50. Write: Mr. George Kudravetz, Product Manager, NTIS, United States Department of Commerce, 5285 Port Royal Road, Springfield, Virginia 22161 and send a copy of your initial correspondence to Canadian Consulate, 3 Parkway Building, Suite 1310, Philadelphia, Pennsylvania 19102.

**Novel Microscope Slide Smoker**

**PAT-APPL-6-003 149/291**

**Nouvel appareil fumigène pour revêtir des lames de microscope**

Filed 15 Jan 79, AD-D006 498/0. Department of the Army. The invention relates to a novel smoker device for providing a layer of smoke reactant on a laboratory microscope slide. The invention further relates to a device for safely burning a magnesium ribbon to provide a magnesium oxide layer on a microscope slide for measuring airborne droplets. Price: PC U.S. \$5.00/MF U.S. \$3.50. Write: Mr. George Kudravetz, Product Manager, NTIS, United States Department of Commerce, 5285 Port Royal Road, Springfield, Virginia 22161 and send a copy of your initial correspondence to Canadian Consulate, 3 Parkway Building, Suite 1310, Philadelphia, Pennsylvania 19102.

**Optical Indexing System**

**PAT-APPL-6-008 675/291**

**Appareil de positionnement optique**

Filed 2 Feb 79, AD-D006 390/9. Department of the Army. A T.V. camera, mounted on the arm of a teleoperator remotely controlled grasping hand, is used to view an object to be grasped through an in-line semi-reflective mirror and a laterally disposed reflective mirror. Alignment of the teleoperator with the object is indicated by a single superimposed image of the object on the television viewing screen. Non-alignment of the teleoperator hand and the object is indicated by double images. Price: PC U.S. \$5.00/MF U.S. \$3.50. Write: Mr. George Kudravetz, Product Manager, NTIS, United States Department of Commerce, 5285 Port Royal Road, Springfield, Virginia 22161 and send a copy of your initial correspondence to Canadian Consulate, 3 Parkway Building, Suite 1310, Philadelphia, Pennsylvania 19102.

**Telemetric System**

**PAT-APPL-6-009 003/291**

**Dispositif de télémétrie**

Filed 5 Feb 79, AD-D006 391/7. Department of the Army. The telemetric system has a conductive coil positioned adjacent to a muzzle. A burst of transducer data is electromagnetically relayed to the conductive coil from a missile after it is fired. This conductive coil has longitudinally spaced windings distributed alongside the trajectory of the missile. The effective length of the conductive coil is at least in the order of magnitude of the distance traveled by the missile while the burst of transducer data is being transmitted. Data thus received can be utilized to drive recorders or similar equipment. The missile has on its outside an associated missile coil for transmitting the burst of transducer data. The coil is driven by a modulated carrier. This modulation is provided by a delay device that is driven by a transducer. This arrangement allows transmission of data corresponding to an operating parameter of the missile after a predetermined delay. Price: PC U.S. \$5.00/MF U.S. \$3.50. Write: Mr. George Kudravetz, Product Manager, NTIS, United States Department of Commerce, 5285 Port Royal Road, Springfield, Virginia 22161 and send a copy of your initial correspondence to Canadian Consulate, 3 Parkway Building, Suite 1310, Philadelphia, Pennsylvania 19102.

**Helicopter Performance Calculator**

**PAT-APPL-6-012 418/291**

**Calculateur de charge d'hélicoptère**

Filed 15 Feb 79, AD-D006 501/1. Department of the Army. A specialized electronic calculator for providing to helicopter pilots an immediate computation and readout of the helicopter's hover performance capability. The invention provides helicopter pilots with the power available and the maximum gross weight which the helicopter is able to hover simply by keying into the calculator the outside air temperature and the pressure altitude. Price: PC U.S. \$5.00/MF U.S. \$3.50. Write: Mr. George Kudravetz, Product Manager, NTIS, United States Department of Commerce, 5285 Port Royal Road, Springfield, Virginia 22161 and send a copy of your initial correspondence to Canadian Consulate, 3 Parkway Building, Suite 1310, Philadelphia, Pennsylvania 19102.

**Differential Pressure Gauge**

**PAT-APPL-6-020 890/291**

**Indicateur de pression différentielle**

Filed 15 Mar 79, AD-D006 394/1. Department of the Army. A gauge for measuring differential pressure in an explosive blast wave, wind tunnel, or shock tube, utilizes a tubular housing having a conical axially aligned inlet port, a cylindrical cavity which is divided into fore and aft sections by a transversely disposed pressure responsive diaphragm. A plurality of symmetrically disposed off-set stagnation inlet tubes and a plurality of circumferentially positioned flow compensated side-on overpressure input slots are used to communicate with each of the respective fore and aft sections of the cavity. Variation in stagnation and side-on overpressures cause diaphragm movement which is detected by a friction-free sensing member. Price: PC U.S. \$5.00/MF U.S. \$3.50. Write: Mr. George Kudravetz, Product Manager, NTIS, United States Department of Commerce, 5285 Port Royal Road, Springfield, Virginia 22161 and send a copy of your initial correspondence to Canadian Consulate, 3 Parkway Building, Suite 1310, Philadelphia, Pennsylvania 19102.

**Sampling Valve****PAT-APPL-6-023 109/291 Robinet d'échantillonnage**

Filed 23 Mar 79, AD-D006 395/8. Department of the Army. A fail-safe pneumatically operated by-pass sampling valve suitable for use in hazardous chemical processes utilizes a manually operated spool valve to initiate a pneumatically operated piston driven crank to rotate a sampling valve. The sampling valve withdraws a sample amount of fluid from a process line without disturbing normal process flow. A pneumatically connected spindle valve and a plurality of limiting valves are proximately positioned and operatively connected to the piston to automatically move the piston actuating member from a normally closed non-sampling position to a sampling position and then back to a normally closed non-sampling position. Price: PC U.S. \$5.00/MF U.S. \$3.50. Write: Mr. George Kudravetz, Product Manager, NTIS, United States Department of Commerce, 5285 Port Royal Road, Springfield, Virginia 22161 and send a copy of your initial correspondence to Canadian Consulate, 3 Parkway Building, Suite 1310, Philadelphia, Pennsylvania 19102.

**In-Bore Telemetry Information Measuring System****PAT-APPL-6-024 140/291 Dispositif de télémessure de la tenue en canon des munitions**

Filed 26 Mar 79, AD-D006 396/6. Department of the Army. The present invention relates to the design, development and malfunction investigations of the tube-fired munitions. More particularly, the invention herein relates to a low cost system for the telemetering of delayed high-G in-bore information. In the past, certain techniques for acquiring in-bore information have not been completely satisfactory in furnishing a complete environmental profile of a shell while in-bore. These techniques have included: (1) Hardwiring of the shell transducer directly to recording equipment located outside the gun tube. This technique suffered from the problem of wire breakage at higher firing zones. (2) Radio frequency transmission of in-bore data out of the gun tube to the ground station recording equipment. This has often been less than optimum due to blow-by gases attenuating the R.F. signal, reflections, and cancellations in the gun tube. (3) Laser beam transmission of in-bore data out of the gun tube. This has not been successful due to difficult alignment problems of transmitter and receiver, and obscuration of the light beam by blow-by gases. The aforementioned radio frequency technique utilized a particular charge-coupled analog delayed device (CCD) to delay in-bore information until the projectile clears the gun barrel and the ionized cloud. Price: PC U.S. \$5.00/MF U.S. \$3.50. Write: Mr. George Kudravetz, Product Manager, NTIS, United States Department of Commerce, 5285 Port Royal Road, Springfield, Virginia 22161 and send a copy of your initial correspondence to Canadian Consulate, 3 Parkway Building, Suite 1310, Philadelphia, Pennsylvania 19102.

**Pressure Relief Manometer****PAT-APPL-6-026 371/291 Manomètre détenteur**

Filed 2 Apr 79, AD-D006 397/4. Department of the Army. This invention relates to manometers and more particularly to a manometer adapted to contain and control mercury spillage in the laboratory. Manometer systems for measuring changes of gas pressures are well-known. Prior art devices generally comprise a U-tube, constructed of a glass tubing having one end open to the atmosphere, and the other to the region where the pressure is to be measured. Another type has one end of the om; U-tube to the pressure region and the other end is sealed off after evacuation. Where the pressure is different from atmospheric, the liquid with which the manometer is partially filled will stand higher in one leg of the tube than in the other. However, sudden pressure surges during testing can frequently be of sufficient magnitude to blow mercury out of the apparatus. If the end of the manometer is sealed the sudden impact against the seal end of the glass tubing would strike with sufficient force to break the tubing and cause mercury spillage on to personnel, equipment and the laboratory area. Since mercury is toxic, it is a peril to personnel and it must be properly controlled preferably within the containing unit. In addition, certain U-type manometers have the disadvantages of the weight of the mercury resting on one arm of the manometer causing a weak point at the base of the U-tube. Price: PC \$5.00/MF U.S. \$3.50. Write: Mr George Kudravetz, Product Manager, NTIS, United States Department of Commerce, 5285 Port Royal Road, Springfield, Virginia 22161 and send a copy of your initial correspondence to Canadian Consulate, 3 Parkway Building, Suite 1310, Philadelphia, Pennsylvania 19102.

**Vent Actuated Shorting Switch****PAT-APPL-6-027 203/291 Interrupteur court-circuiteur à pression**

Filed 5 Apr 79, AD-D006 485/7. Department of the Army. In a high voltage, high ampere battery, a shorting bar is placed on the top of each battery cell vent cap for providing a shorting switch between two extensions from respective cell terminals in response to excessive cell pressure dislocating the vent cap. This effectively removes a defective, potentially explosive cell from the battery output circuit while continuing to apply an output voltage to using circuitry. Price: PC U.S. \$5.00/MF U.S. \$3.50. Write: Mr. George Kudravetz, Product Manager, NTIS, United States Department of Commerce, 5285 Port Royal Road, Springfield, Virginia 22161 and send a copy of your initial correspondence to Canadian Consulate, 3 Parkway Building, Suite 1310, Philadelphia, Pennsylvania 19102.

**Crashworthy Fuel System****PAT-APPL-6-028 040/291 Circuit d'alimentation résistant à l'écrasement**

Filed 9 Apr 79, AD-D006 503/7. Department of the Army. A crashworthy fuel system for aircraft or the like comprising a

fuel tank and a valve for securement to the bottom of the tank. The valve comprises a generally L-shaped body having a first leg and a second leg extending generally at right angles to the first leg. A main flow passage extends through the entire length of the body. The first leg has a peripheral flange spaced from its outer end which is secured in face-to-face relation to the bottom of the tank with the outer end of the first leg extending up through a hole in the bottom of the tank into the interior of the tank for flow of fuel into the main flow passage and the second leg extending below the tank on the outside thereof for connection at its outer end to a fuel delivery line. The second leg has a circumferential area of weakness adjacent the flange between the flange and the first leg. A valve is provided in the main flow passage between this area of weakness and the inlet end of the main flow passage for sealing the main flow passage in the event of rupture of the valve body at the area of weakness, as during a crash of the aircraft. A valve is also provided toward the outlet end of the main flow passage for draining the latter. Price: PC U.S. \$5.00/MF U.S. \$3.50. Write: Mr. George Kudravetz, Product Manager, NTIS, United States Department of Commerce, 5285 Port Royal Road, Springfield, Virginia 22161 and send a copy of your initial correspondence to Canadian Consulate, 3 Parkway Building, Suite 1310, Philadelphia, Pennsylvania 19102.

#### **Variable Length Linkage**

**PAT-APPL-6-034 062/291    Tringlerie à longueur variable**

Filed 27 Apr 79, AD-D006 504/5. Department of the Army. A mechanical linkage is disclosed having male and female mating portions, said linkage being adjustable to a selected length and said male member carrying a locking means for simultaneously engaging the male and female members and for locking them in relative mated position. Among the several objects of the present invention may be noted the provision of a variable length mechanical linkage for connecting a variable geometry actuator to a variable geometry linkage assembly in a gas turbine engine. Another object is to provide a variable length mechanical linkage for use wherever the specifications disallow a conventional turnbuckle assembly with a lockwire. Price: PC U.S. \$5.00/MF U.S. \$3.50. Write: Mr. George Kudravetz, Product Manager, NTIS, United States Department of Commerce, 5285 Port Royal Road, Springfield, Virginia 22161 and send a copy of your initial correspondence to Canadian Consulate, 3 Parkway Building, Suite 1310, Philadelphia, Pennsylvania 19102.

#### **Process and Composition of Low Toxicity for Preparing Aluminium Surfaces for Adhesive Bonding**

**PAT-APPL-6-037 210/291    Utilisation et préparation d'une solution solution peu toxique servant au décapage pré-assemblage des surfaces d'aluminium**

Filed 9 May 79, AD-D006 400/6. Department of the Army. A principal object of the present invention is to provide a novel process and composition for etching aluminum, which utilizes neither chromate nor nitric acid and produces aluminum surfaces, which when adhesively bonded yield joints of comparable strength and stress durability to those obtained by use of either the standard chromate etch or the chromate-free nitric acid etch of the patent. Other objects will become apparent as the invention is further described. These and other objects are achieved according to the present invention by contacting the aluminum parts with an etchant composition consisting essentially of an aqueous solution of sulfuric acid and ferric sulfate. Price: PC U.S. \$5.00/MF U.S. \$3.50. Write: Mr. George Kudravetz, Product Manager, NTIS, United States Department of Commerce, 5285 Port Royal Road, Springfield, Virginia 22161 and send a copy of your initial correspondence to Canadian Consulate, 3 Parkway Building, Suite 1310, Philadelphia, Pennsylvania 19102.

#### **Active Optical Filter**

**PAT-APPL-6-043 876/291    Filtre optique actif**

Filed 30 May 79, AD-D006 403/0. Department of the Army. An active optical filter comprising a device which utilizes a phenomenon known as 'total internal reflection'. Two prisms are provided with a medium interposed between them. The index of refraction of the interposed medium is one which will change and decrease the light-transmitting properties of the filter with an increase in intensity of the incident light to form an optical switch which limits the transmitted light above certain power levels. These power levels are often found in Q-switched laser pulses. Price: PC U.S. \$5.00/MF U.S. \$3.50. Write: Mr. George Kudravetz, Product Manager, NTIS, United States Department of Commerce, 5285 Port Royal Road, Springfield, Virginia 22161 and send a copy of your initial correspondence to Canadian Consulate, 3 Parkway Building, Suite 1310, Philadelphia, Pennsylvania 19102.

#### **Rapid Water Activity Determining Device and Method**

**PAT-APPL-6-044 125/291    Appareil et méthode pour déterminer rapidement la teneur (activité) en eau**

Filed 31 May 79, AD-D006 404/8. Department of the Army. Apparatus and method for determining the water activity ( $A_w$ ) of a water-containing composition, such as a food, within approximately 10 minutes, by rapidly establishing equilibrium between the water-containing composition and the atmosphere with which it is in contact while maintaining the temperature substantially constant and determining the dew point of this atmosphere, from which the water activity is calculable from the ratio of the partial water vapor pressure at the dew point to the vapor pressure of pure water at the temperature of the atmosphere with which the water-containing composition is in equilibrium. Price: PC U.S. \$5.00/MF U.S. \$3.50. Write: Mr. George Kudravetz, Product Manager, NTIS, United States Department of Commerce, 5285 Port Royal Road, Springfield, Virginia 22161 and send a copy of your initial correspondence to Canadian Consulate, 3 Parkway Building, Suite 1310, Philadelphia, Pennsylvania 19102.

**Apparatus for Measuring Anti-Wear Properties of Pressurized Liquids**

**PAT-APPL-6-044 898/291**

**Appareil de mesure de propriétés anti-usure des liquides sous pression**

Filed 4 Jun 79, AD-D006 405/5. Department of the Army. A testing device for determining the lubrication properties of hydraulic fluids under elevated pressures and temperatures comprises a pressure-tight housing defining a central cavity including a continuous passageway for the fluid, a chuck assembly located within the cavity which holds a plurality of test balls in fixed position, rotatable support structure securing an upper ball in centrally disposed contact with the test balls, and a screw-threaded adjustment adapted to move the chuck assembly to apply pressure between the test balls and the upper ball. The present testing device is of simple and inexpensive construction and reduced size and provides data respecting the test fluids which accurately reflects actual working conditions. Price: PC U.S. \$5.00/MF U.S. \$3.50. Write: Mr. George Kudravetz, Product Manager, NTIS, United States Department of Commerce, 5285 Port Royal Road, Springfield, Virginia 22161 and send a copy of your initial correspondence to Canadian Consulate, 3 Parkway Building, Suite 1310, Philadelphia, Pennsylvania 19102.

**Microwave Frequency Discriminator**

**PAT-APPL-6-046 420/291**

**Discriminateur de fréquence hyper-fréquences**

Filed 7 Jun 79, AD-D006 483/2. Department of the Army. The input signal is split by a magic tee and is reflected back into the magic tee by two shorts. One of the shorts has a length of line which is adjustable to a particular frequency. Two outputs from the magic tee are sent to two detectors and then to a differential amplifier to establish the difference between the outputs of the two detectors which becomes proportional to the difference in the frequency of the input signal and the frequency of the tuned microwave length of line. Price: PC U.S. \$5.00/MF U.S. \$3.50. Write: Mr. George Kudravetz, Product Manager, NTIS, United States Department of Commerce, 5285 Port Royal Road, Springfield, Virginia 22161 and send a copy of your initial correspondence to Canadian Consulate, 3 Parkway Building, Suite 1310, Philadelphia, Pennsylvania 19102.

**Laminated, Highly Sorbent, Active Carbon Fabric**

**PAT-APPL-6-046 733/291**

**Tissu laminé très absorbant contenant du carbone activé**

Filed 7 Jun 79, AD-D006 406/3. Department of the Army. An object of the invention is to provide a laminated, highly sorbent, active carbon fabric that will be permeable to moisture vapor, resistant to sweat penetration and have low levels of thermal insulation while being capable of sorbing substantial amounts of toxic chemical vapors and, therefore, of preventing such chemical vapors from penetrating through clothing made of such fabric to the skin of wearers of such clothing. Another object of the invention is to provide a process for making a highly sorbent, active carbon fabric having characteristics such as those described in the preceding paragraph. Price: PC U.S. \$5.00/MF U.S. \$3.50. Write: Mr. George Kudravetz, Product Manager, NTIS, United States Department of Commerce, 5285 Port Royal Road, Springfield, Virginia 22161 and send a copy of your initial correspondence to Canadian Consulate, 3 Parkway Building, Suite 1310, Philadelphia, Pennsylvania 19102.

**Method of Growing Single Crystals**

**PAT-APPL-6-046 961/291**

**Méthode de croissance de monocristaux**

Filed 9 Jun 79, AD-D006 407/1. Department of the Army. The general object of this invention is to provide a method of growing single crystals of Berlinite, wherein the single crystals grown will be of large size, high purity, and exceptional quality. The resulting crystals can be used as temperature compensated piezoelectric material in applications such as resonators for oscillators and filters, delay lines, and frequency filters for correlation, pulse compression, and matched filtering. The foregoing objects now have been attained by growing single crystals of alpha aluminum phosphate from seeded solutions of aluminum orthophosphate and orthophosphoric acid in such a manner as to provide direct visual observation of the crystal growth process and allow precise determination of nucleation and growth kinetics. Price: PC U.S. \$5.00/MF U.S. \$3.50. Write: Mr. George Kudravetz, Product Manager, NTIS, United States Department of Commerce, 5285 Port Royal Road, Springfield, Virginia 22161 and send a copy of your initial correspondence to Canadian Consulate, 3 Parkway Building, Suite 1310, Philadelphia, Pennsylvania 19102.

**A Simple Method of Switching an AC Line**

**PAT-APPL-6-050 250/291**

**Méthode simple de commutation pour ligne alimentée en alternatif**

Filed 20 Jun 79, AD-D006 484/0. Department of the Army. A switching circuit for an alternating current line allows the voltage or current coupled from the line to a load circuit to be controlled. Control may be in response to changes in voltage or current coupled as a feedback signal from the load to a switching circuit in the line for applying or terminating alternating current line voltages. In an alternative embodiment, a switching circuit is initiated at the time alternating current voltages are applied to a load and after a predetermined time interval the switching circuit operates to disconnect and lock out the alternating current voltage. Price: PC U.S. \$5.00/MF U.S. \$3.50. Write: Mr. George Kudravetz, Product Manager, NTIS, United States Department of Commerce, 5285 Port Royal Road, Springfield, Virginia 22161 and send a copy of your initial correspondence to Canadian Consulate, 3 Parkway Building, Suite 1310, Philadelphia, Pennsylvania 19102.

**Multilayer Laminate of Improved Resistance to Fatigue Cracking and Method for Producing Same** PAT-APPL-6-051 780/291 **Description et méthode de fabrication d'un laminé multicouches moins susceptible de produire des criques à la fatigue**

Filed 25 Jun 79, AD-D006 409/7. Department of the Army. A multilayer bi-metallic laminate of improved resistance to the initiator and propagation of fatigue cracking and fracture is obtained by intimately bonding, alternate sheets of the two metals one of the metals having a modulus of elasticity at least 20% greater than the other metal. Prior to the bonding step the sheets of the stronger metal are stretched so that when they are released after the bonding step they are left in a state of residual tension while the sheets of the weaker metal are left in a state of residual compression. The residual compression in the weaker metal inhibits fatigue cracking of the laminate while the residual tension in the stronger metal has little effect on the crack resistance thereof. Price: PC U.S. \$5.00/MF U.S. \$3.50. Write: Mr. George Kudravetz, Product Manager, NTIS, United States Department of Commerce, 5285 Port Royal Road, Springfield, Virginia 22161 and send a copy of your initial correspondence to Canadian Consulate, 3 Parkway Building, Suite 1310, Philadelphia, Pennsylvania 19102.

**Method of Making a Ruggedized High Current Density Cathode** PAT-APPL-6-051 934/291 **Méthode de fabrication d'une cathode robuste à haute densité de courant**

Filed 25 Jun 79, AD-D006 410/5. Department of the Army. A high current density cathode capable of operating at current densities of 2A/sq cm to 30A/sq cm in the temperature range of 900 degrees C to 1125 degrees C is prepared by machining a porous high purity tungsten pellet containing copper in its pores and also containing about 0.6 to 2 weight percent of an activator to the desired cathode shape without reducing the pores of the emitter pellet. The pellet is then fired at 1800 degrees C in a non-oxidizing atmosphere to remove the copper filler material. The pellet is then impregnated with the Ba5Sr(WO6)2 at a temperature of 1900 degrees C in a dry inert gas atmosphere and the impregnated emitter then fired in dry hydrogen atmosphere at about 1840 degrees C for about 2.5 to 5 minutes. Price: PC U.S. \$5.00/MF U.S. \$3.50. Write: Mr. George Kudravetz, Product Manager, NTIS, United States Department of Commerce, 5285 Port Royal Road, Springfield, Virginia 22161 and send a copy of your initial correspondence to Canadian Consulate, 3 Parkway Building, Suite 1310, Philadelphia, Pennsylvania 19102.

**CO Chemical Laser Produced by Laser Induced Chemistry of CSC12** PAT-APPL-6-052 045/291 **Production de CO par irradiation laser de CSC12**

Filed 25 Jun 79, AD-D006 486/5. Department of the Army. The R(48) (1/992 cm) line of a tunable cw multiline CO2 laser is used to dissociate thiophosgene (CSC12) to produce the excited radical, CS\*, homogeneously in a laser chamber containing premixed O2. The R(48) (1/992 cm) line of the CO2 laser is resonant with the 2v2 (1/992 cm) overtone of CSC12. This line is strongly absorbed by the CSC12 which dissociates (80%) into 2 CI and CS\*. The CS\* reacts with the premixed O2 to chemically produce excited CO which subsequently lases. Price: PC U.S. \$5.00/MF U.S. \$3.50. Write: Mr. George Kudravetz, Product Manager, NTIS, United States Department of Commerce, 5285 Port Royal Road, Springfield, Virginia 22161 and send a copy of your initial correspondence to Canadian Consulate, 3 Parkway Building, Suite 1310, Philadelphia, Pennsylvania 19102.

**Apparatus and Method for Determining Electrical Conductivity of Water Vapor** PAT-APPL-6-055 716/291 **Appareil et méthode de détermination de la conductivité électrique de la vapeur d'eau**

Filed 9 Jul 79, AD-D006 411/3. Department of the Army. An apparatus and method are disclosed for measuring the conductivity or number of water ion clusters present in a moist air environment. A test chamber is utilized for operatively simultaneously holding a 'dummy' reference cell and a 'large' conductivity cell having substantially the same leakage resistance. The cells are designed to have 'cell factor' ratios substantially different from each other. A D.C. power source with an in series vacuum-tube voltmeter is used to alternately measure the voltage drop of each cell under the similar variable ambient conditions. The conductivity or number of ion cluster present in the test environment is determined by a calculation using voltage compensated values and by graphical extrapolation. Price: PC U.S. \$5.00/MF U.S. \$3.50. Write: Mr. George Kudravetz, Product Manager, NTIS, United States Department of Commerce, 5285 Port Royal Road, Springfield, Virginia 22161 and send a copy of your initial correspondence to Canadian Consulate, 3 Parkway Building, Suite 1310, Philadelphia, Pennsylvania 19102.

**Novel Aqueous Foam Formulation and Method** PAT-APPL-6-069 034/291 **Méthode de préparation et d'utilisation d'une nouvelle mousse aqueuse**

Filed 23 Aug 79, AD-D006 412/1. Department of the Army. The invention relates to a new, stable high-expansion aqueous foam formulation containing dibenz-(b,f)-1,4-oxazepine and stabilizers selected from glycerine, carboxyl vinyl polymers, and mixtures thereof. The invention also relates to a method of obtaining visual obscuration and area denial in military operations through use of a novel, stable, high-expansion aqueous foam formulation containing dibenz-(b,f)-1,4-oxazepine

in sufficient quantities to provide area denial for extended periods of time. The invention further relates to an aqueous foam formulation which will remain stale even when stored for extended periods of time under severe environmental stress conditions. The invention still further relates to an aqueous foam formulation containing dibenz-(b,f)-1,4-oxaepine as a deterrent which will adhere to the surfaces of objects or persons entering or moving about in a foam generated from the formulation. The invention also relates to a foam formulation which can be used as a single composite solution or as two separate solutions to be mixed immediately prior to foam generation in conventional fire fighting foam generators. Prior foam formulations have generally been adequate for achieving visual obscuration for short periods of time. Previous studies on foam formulations have used high expansion foams as carriers for selected deterrent chemicals such as military tear gas (CS), but these foams have exhibited inadequate foam stability in conjunction with a high liquid drainage rate. Only short-term effectiveness in visual obscuration and area denial have been achieved. Price: PC U.S. \$5.00/MF U.S. \$3.50. Write: Mr. George Kudravetz, Product Manager, NTIS, United States Department of Commerce, 5282 Port Royal Road, Springfield, Virginia 22161 and send a copy of your initial correspondence to Canadian Consulate, 3 Parkway Building, Suite 1310, Philadelphia, Pennsylvania 19102.

**Apparatus for the Controlled  
Discharge of a Charged Object**

**PAT-APPL-6-078 628/291 Appareil de décharge contrôlée de corps  
électrisés**

Filed 25 Sep 79, AD-D006 509/4. Department of the Army. The invention concerns a grounding device for discharging a charged helicopter or the like and comprises, in one embodiment, a nylon or Teflon stringer having a metal weight at one end and a metal connector at the other. A plurality of spherical, graded resistance conductive ceramic beads and conductive points are strung on the stringer to form a flexible self-cleaning discharge device. Price: PC U.S. \$5.00/MF U.S. \$3.50. Write: Mr. George Kudravetz, Product Manager, NTIS, United States Department of Commerce, 5285 Port Royal Road, Springfield, Virginia 22161 and send a copy of your initial correspondence to Canadian Consulate, 3 Parkway Building, Suite 1310, Philadelphia, Pennsylvania 19102.

**Modular Assembly of a Photovoltaic  
Solar Energy Receiver**

**PAT-APPL-829 122/291 Capteur solaire photovoltaïque  
modulaire**

Filed 30 Aug 77, ERA citation 04:052795. There is provided a modular assembly of a solar energy concentrator having a photovoltaic energy receiver with passive cooling. Solar cell means are fixedly coupled to a radiant energy concentrator. Tension means bias a large area heat sink against the cell thereby allowing the cell to expand or contract with respect to the heat sink due to differential heat expansion. Price PC U.S. \$5.00/MF U.S. \$3.50. Write: James E. Denny, Assistant General Counsel for Patents, Officer of the General Counsel, U.S. Department of Energy, Washington, D.C. 20545 and send a copy of your initial correspondence to Canadian Consulate, 3 Parkway Building, Suite 1310, Philadelphia, Pennsylvania 19102.

**Aziridinyl Quinone Antitumor Agents**

**PAT-APPL-954 218/291 Agents antitumorigènes à base d'aziridyl-  
quinone**

Filed 24 Oct 78, PB80-114895. Department of Health, Education, and Welfare. The use of aziridinyl quinones as antitumor agents is disclosed. A compound which has been found to be particularly effective is the compound 2,5-diaziridinyl-3,6-bis (carboethoxyamino)-1,4-benzoquinone. Treatment is described in connection with various forms of leukemia, for example, as well as B16 melanoma, Lewis lung carcinoma, and the ependymoblastoma brain tumor system. Price: PC U.S. \$6.00/MF U.S. \$3.50. Write: Mr. George Kudravetz, Product Manager, NTIS, United States Department of Commerce, 5282 Port Royal Road, Springfield, Virginia 22161 and send a copy of your initial correspondence to Canadian Consulate, 3 Parkway Building, Suite 1310, Philadelphia, Pennsylvania 19102.

**Carbocyclic Analogs of Cytosine  
Nucleosides**

**PAT-APPL-6-058 177/291 Analogues carbocycliques de nucléo-  
sides de la cytosine**

Filed 17 Jul 79, PB80-114846. Department of Health, Education and Welfare. Novel compounds are disclosed which are (carbocyclic analogs of cytosine nucleosides) in which the pentose moiety of the nucleoside is replaced by a cyclopentane ring. The novel compounds exhibit antiviral activity and certain of them also exhibit antineoplastic activity against the L 1210 mouse leukemia test system. Price: PC U.S. \$6.00/MF \$3.50. Write: Mr. George Kudravetz, Product Manager, NTIS, United States Department of Commerce, 5285 Port Royal Road, Springfield, Virginia 22161 and send a copy of your initial correspondence to Canadian Consulate, 3 Parkway Building, Suite 1310, Philadelphia, Pennsylvania 19102.

**Clot Lysing Timer**

**PAT-APPL-6-063 261/291 Appareil de mesure du temps de lyse d'un  
caillot**

Filed 2 Aug 79, PB80-114887. Department of Health, Education, and Welfare. A clot lysing timing device consisting of a thermostatically controlled assembly including heated blocks formed with wells to receive precooled test tubes containing

liquid with clots formed by the addition of thrombin to plasma (or to a mixture of fibrinogen and plasminogen) containing varying quantities of urokinase, streptokinase or plasmin. The blocks are maintained at 37 C when a precooled test tube with such contents is placed in one of the 37 C wells it activates a microswitch which starts a corresponding timer channel. An opaque sphere is placed on top of the clot. As the clot dissolves (at a rate depending on the quantity of lytic agent incorporated in the clot) the sphere travels to the bottom of the test tube, interrupting an infra red light beam, which stops the corresponding timer channel. The time counts from the respective timer channels can be selectively displayed on an LED digital readout device. Price: PC U.S. \$5.00/MF U.S. \$3.50. Write: Mr. George Kudravetz, Product Manager, NTIS, United States Department of Commerce, 5285 Port Royal Road, Springfield, Virginia 22161 and send a copy of your initial correspondence to Canadian Consulate, 3 Parkway Building, Suite 1310, Philadelphia, Pennsylvania 19102.

**Curing Agent for Polyepoxides and Epoxy Resins and Composites Cured Therewith**

**PAT-APPL-6-070 771/291 Agent de vulcanisation pour polyépoxydes et résines d'époxy et composés traités par cet agent**

Filed 30 Aug 79, N79-31345/8, NASA-CASE-LEW-13226-1. A curing agent for a polyepoxide is described which contains a divalent aryl radical such as phenylene and a tetravalent aryl radical such as a tetravalent benzene radical. An epoxide is cured by admixture with the curing agent. The cured epoxy product retains the usual properties of cured epoxides and, in addition, has a high char residue after burning, on the order of 45% by weight. The high char residue is of value in preventing release to the atmosphere of carbon fibers from carbon fiber-epoxy resin composites in the event of burning of the composite. Price: PC U.S. \$5.00/MF U.S. \$3.50. Write: NASA, Lewis Research Center, 21000 Brookpark Road, Cleveland, Ohio 44135 and send a copy of your initial correspondence to Canadian Consulate, Illuminating Building, 55 Public Square, Cleveland, Ohio 44113.

**Multistage Depressed Collector for Dual Node Operation**

**PAT-APPL-6-073 579/291 Collecteur concave en cascade adapté à deux nodes de fonctionnement**

Filed 7 Sep 79, N79-32463/8, NASA-CASE-LEW-13282-1. A depressed collector is described which captures the spent electrons of a microwave transmitting tube at high efficiency in both high and low power modes of operation. The end electrode has a spike extending toward the entrance electrode. Intermediate electrodes and the entrance electrode have central apertures increasing in size in a downstream direction. These electrodes capture most high power mode spent electrons. A low power mode electrode is positioned between the last intermediate electrode and the end electrode to capture low power spent electrons. This electrode has a central aperture preferably smaller but no larger than that of the last intermediate electrode. An auxiliary low power mode electrode with a central aperture larger than that of the low power mode electrode may be axially positioned between the end electrode and the low power mode electrode. The electrodes are all at voltages provided by a voltage divider connected between a negative potential and a common ground return. Price: PC U.S. \$5.00/MF U.S. \$3.50. Write: NASA, Lewis Research Center, 21000 Brookpark Road, Cleveland, Ohio 44135 and send a copy of your initial correspondence to Canadian Consulate, Illuminating Building, 55 Public Square, Cleveland, Ohio 44113.

**A System for Sterilizing Objects**

**PAT-APPL-6-046 739/291 Système de stérilisation d'objets**

Filed 8 Jun 79, N79-33848/9, NASA-CASE-KSC-11085-1. A system for producing a stream of humidified sterilizing gas for sterilizing objects such as the water systems space vehicles is described. The system includes a source of sterilant gas which is fed to a mixing chamber having inlet and outlet ports. Water is carried in the mixing chamber, with the level of the water only partially filling the mixing chamber, to provide an empty space adjacent the top of the chamber. A heater is provided for heating the water in the chamber producing a humidified atmosphere. The sterilant gas is fed through an arcuate shaped tubular member connected to the inlet port of the mixing chamber to produce a vortex type of flow in the sterilant gas being humidified. A tubular member extends from the mixing chamber to supply the humidified sterilant gas to the object to be sterilized. Scrubbers are provided for removing the sterilant gas after use. Price: PC U.S. \$5.00/MF U.S. \$3.50. Write: NASA, John F. Kennedy Space Center, Mail Code SA-PAT, Kennedy Space Center, Cocoa Beach, Florida 32899 and send a copy of your initial correspondence to Canadian Consulate General, 900 Coastal States Building, 260 Peachtree Street, Atlanta, Georgia 30303.

**Safety Shield for Vacuum/Pressure Chamber Viewing Port**

**PAT-APPL-6-053 571/291 Ecran protecteur de fenêtre de chambre sous vide ou sous pression**

Filed 29 Jun 79, N79-32217/8, NASA-CASE-GSC-12513-1. An optically clear safety shield, formed from a plate of Plexiglas, is mounted in a spaced-apart relationship from the viewing port on the other surface of a vacuum or high pressure chamber. Because of the air gap between the viewing port and the safety shield, the shield is not subject to the cyclic stresses placed on the viewing window which tend to make it fail. Flying debris from a shattered viewing port window is deflected by the safety shield away from personnel and instruments in the vicinity of the chamber. Price: PC U.S. \$5.00/MF U.S. \$3.50.

Write: NASA, Goddard Space Flight Center, Mail Code 204, Greenbelt, Maryland 20771 and send a copy of your initial correspondence to Canadian Consulate, 3 Parkway Building, Suite 1310, Philadelphia, Pennsylvania 19102.

**Environmental Fog/Rain Visual Display    PAT-APPL-6-053 566/291    Système d'affichage vidéo des conditions météorologiques de brouillard/pluie pour les simulateurs d'aéronef**

Filed 29 Jun 79, N79-33220/1, NASA-CASE-ARC-11158-1. A combination of electronic and mechanical integrated elements which operate together are used to produce realistic environmental conditions that would actually be encountered by a pilot flying an aircraft. The electronic elements of the system include a real time digital computer, a calligraphic color display which simulates landing lights of selective intensity, and a color television camera for producing a moving color display of the airport runway as depicted on a model terrain board. The mechanical simulation elements of the system include an environmental chamber which can produce natural fog, nonhomogeneous fog, rain and fog combined, or rain only. A pilot looking through the aircraft windscreen will look through the fog and/or rain generated in the environmental chamber on to a viewing screen with the simulated color image of the airport runway, and observe a very real simulation of actual conditions of a runway as it would appear through actual fog and/or rain. Price: PC U.S. \$10.00/MF U.S. \$3.50. Write: NASA, Ames Research Center, Mail Code 200-11A, Moffett Field, California 94035 and send a copy of your initial correspondence to Canadian Consulate General, One Maritime Plaza, Alcoa Building, Suite 1100, Golden Gateway Center, San Francisco, California 94111.

**Pressure Control Valve    PAT-APPL-6-057 465/291    Soupape pour contrôle de la pression**

Filed 13 Jul 79, N79-30553/8, NASA-CASE-ARC-11251-1. A control valve is described which is adapted to be connected between a pressure source, such as a vacuum pump, and a pressure vessel to control the pressure in the vessel. The valve comprises a housing having a longitudinal bore which is connected between the pump and vessel, and a transversely movable valve body which controls the air flow through an air inlet in the housing. The valve body includes cylindrical and conical portions which cooperate with reciprocally shaped portions of the housing to provide flow control. A filter disposed in the air inlet filters out foreign matter in the air. The bottom end of the valve body screws into the valve housing control knob which is formed integrally with the valve body and controls opening and closing of the valve. Price: PC U.S. \$5.00/MF U.S. \$3.50. Write: NASA, Ames Research Center, Mail Code 200-11A, Moffett Field, California 94035 and send a copy of your initial correspondence to Canadian Consulate General, One Maritime Plaza, Alcoa Building, Suite 1100, Golden Gateway Center, San Francisco, California 94111.

**Autonomous Navigation System    PAT-APPL-6-078 611/291    Système de navigation autonome**

Filed 24 Sep 79, N79-33177/3, NASA-CASE-ARC-11257-1. A low cost autonomous navigation system which disposes with accelerometers used in the conventional gimbaled and strapdown inertial systems is described. The navigation system provides longitudinal and lateral vehicular specific force measurements in the locally level plane irrespective of the vehicle pitch, roll, and yaw motions. The navigation system provides longitudinal and lateral velocities in locally level geography coordinates along with vehicle position, altitude and attitude information. The system minimizes the number of sensors and system complexity, thus reducing errors, while providing a rapid method of north calibration. The system is composed of an unbalanced, pendulous, two axis gimbal system with a two degree of freedom leveling gyroscope and a heading gyroscope. Price: PC U.S. \$5.00/MF U.S. \$3.50. Write: NASA, Ames Research Center, Mail Code 200-11A, Moffett Field, California 94035 and send a copy of your initial correspondence to Canadian Consulate General, One Maritime Plaza, Alcoa Building, Suite 1100, Golden Gateway Center, San Francisco, California 94111.

**Precise RF Timing Signal Distribution    PAT-APPL-6-078 521/291    Diffusion d'un signal d'horloge rf précis to Remote Stations    dans les stations éloignées**

Filed 24 Aug 79, N79-34013/9, NASA-CASE-NPO-14749-1. An improved and simplified distribution system is provided for a precise RF reference signal, such as a signal from an H-maser using a light beam from a laser as a frequency carrier, modulating the light beam with the RF timing signal in a modulator, and after distribution to remote stations through optical fibers, demodulating the carrier with an optical detector to detect the RF timing signal. The detected RF reference signal is then processed through an RF detector to provide an automatic gain control (AGC) signal that has an average value proportional to the amplitude of the RF reference signal. This AGC signal is applied to a voltage variable attenuator positioned in front of the RF detector. Since the light frequency is very high, as compared to the RF reference signal, deviation of the reference signal phase is a very small fraction of the RF frequency. In that manner, the timing signal amplitude is maintained constant at each station with substantially zero phase stability degradation. Price: PC U.S. \$5.00/MF U.S. \$3.50. Write: Monte F. Mott, Patent Counsel, NASA Resident Legal Office, Mail Code 180-601, 4800 Oak Grove Drive, Pasadena, California 91103 and send a copy of your initial correspondence to Canadian Consulate General, 510 West Sixth Street, Los Angeles, California 90014.

**Microwave Limb Sounder****PAT-APPL-6-078 612/291 Sondeur de limbe micro-ondes**

Filed 24 Sep 79, N79-34014/7, NASA-CASE-NPO-14544-1. A microwave limb sounder (MLS) to measure trace gases in the upper atmosphere by comparing spectral noise content of limb soundings with the spectral noise content of cold space is disclosed. The sounder utilizes an offset Cassegrain antenna system and a tilttable input mirror to alternately look out at the limb and up at cold space at an elevation angle of about 22 deg. Reflection from the mirror is directed into a radiometer which functions as a diplexer to combine the input radiation and a local oscillator (klystron) beam. The radiometer head is comprised of a Fabry-Perot resonator consisting of two Fabry-Perot cavities spaced a number of half wavelengths apart. Incoming radiation received on one side is reflected and rotated 90 deg. in polarization by the resonator so that it will be reflected by an input grid into a mixer, while the klystron beam, received on the other side is also reflected and rotated 90 deg. Price: PC U.S. \$5.00/MF U.S. \$3.50. Write: Monte F. Mott, Patent Counsel, NASA Resident Legal Office, Mail Code 180-601, 4800 Oak Grove Drive, Pasadena, California 91103 and send a copy of your initial correspondence to Canadian Consulate General, 510 West Sixth Street, Los Angeles, California 90014.

**Longitudinal Rail Profilometer****PAT-APPL-6-090 744/291 Appareil de mesure du profil longitudinal des rails**

Filed 2 Nov 79, PB80-114879, DOT-TSC-10130. Office of the Secretary of Transportation. The patent application describes a portable apparatus for use in measuring vertical deviation of the surface of a rail from a reference plane. The measuring device includes a pair of guide beams and a hand-powered carriage which move along the beams. A sensor, which follows undulations resulting from rail wear, is mounted on the carriage and is coupled to the pen of a recorder. Price: PC U.S. \$5.00/MF U.S. \$3.50. Write: Mr. George Kudravetz, Product Manager, NTIS, United States Department of Commerce, 5285 Port Royal Road, Springfield, Virginia 22161 and send a copy of your initial correspondence to Canadian Consulate, 3 Parkway Building, Suite 1310, Philadelphia, Pennsylvania 19102.

**LICENSING OPPORTUNITIES FROM JAPAN****POSSIBILITÉS D'OBTENTION DE LICENCES DU JAPON****CONTACT:****S'ADRESSER A:**

Mr. Hiroshi Ando  
 Manager  
 Department of Patent License  
 Research Development Corporation of Japan  
 5-2, Nagata-cho 2-chome  
 Chiyoda-ku, Tokyo 100  
 Japan

Monsieur Hiroshi Ando  
 Directeur  
 Service des licences de brevets  
 Corporation de développement des recherches  
 5-2, Nagata-cho 2-chome  
 Chiyoda-ku, Tokyo 100  
 Japon

The following developments, at the production stage, are offered for manufacture in Canada by the RESEARCH DEVELOPMENT CORPORATION OF JAPAN. Enquiries concerning the acquisition of the Canadian manufacturing rights should be addressed to MR. HIROSHI ANDO at the above address with a copy of the initial correspondence sent to: Commercial Division, Embassy of Canada, 3-38 Akasaka 7-chome, Minato-ku, Tokyo 107, Japan. Please quote the full title and reference number of the item you are interested in. At the same time JRDC would prefer to receive any information about you and your activities.

La CORPORATION DE DEVELOPPEMENT DES RECHERCHES du Japon offre les développements suivants, au stade de production, pour la fabrication sous licence au Canada. Les demandes de renseignements concernant l'acquisition des droits de fabrication au Canada doivent être adressées à M. Hiroshi Ando à l'adresse ci-dessus et une copie de la correspondance initiale devrait être envoyée à la Division commerciale de l'ambassade du Canada, 3-38 Akasaka 7-chome, Minato-ku, Tokyo 107, Japon. Veuillez indiquer le titre complet et le numéro de référence de l'article qui vous intéresse. La Corporation aimerait également recevoir en même temps que votre demande des renseignements sur votre entreprise et vos activités.

**Waste Water Treatment by Heavy Metal Ion Adsorbent****JRDC 9325/291**

In this method, using both the conventional neutralization settling-separation method and ion adsorption method, heavy metal ions are selectively adsorbed, unlike in the ion exchange resin method. The amount of adsorbent can be

**Traitement des eaux usées par absorption des ions métalliques lourds JRDC 9325/291**

Cette méthode, qui combine la méthode traditionnelle de neutralisation puis de séparation par sédimentation avec la méthode d'absorption des ions, permet d'absorber sélectivement les ions métalliques lourds, ce que la méthode

small and it can be easily regenerated using hydrochloric acid or nitric acid. The life of the adsorbent is almost permanent and can be replenished by supplying only the worn amount. In this method, the order of heavy metal ion adsorption is  $Pb^{2+} Hg^{2+} > Cu^{2+} Cr^{2+} Fe^{2+} > Cd^{2+} Ni^{2+} Zn^{2+} Mn^{2+}$ , of which lead, mercury, copper, chromium, etc., can be removed particularly effectively. Thus ions contained in the waste water can be controlled at a low concentration level. Furthermore, the BOD and COD values can be improved by arranging a fixed bed activated sludge treatment unit before or after this treatment process, as and when necessary.

classique aux résines échangeuses ne permet pas. La quantité d'absorbant nécessaire reste faible et il est facilement régénéré par l'acide chlorhydrique ou l'acide nitrique. Cet absorbant est pratiquement permanent et il peut être renouvelé en ne remplaçant que la partie usée. Dans cette méthode, l'ordre d'absorption est le suivant:  $Pb^{++}, Hg^{++} > Cu^{++}, Cr^{++}, Fe^{++} > Cd^{++}, Ni^{++}, Zn^{++}, Mn^{++}$ , et le plomb, le mercure, le cuivre, le chrome, etc. peuvent être éliminés très efficacement. Par conséquent, on peut extraire les ions des eaux usées jusqu'à de faibles concentrations. De plus, on peut abaisser la DBO et la DCO en plaçant une unité de traitement à lit fixe de boues activées avant ou après l'absorption, si nécessaire.

**Moving Bed-Type Sand Filter for Suspended Solid** JRDC 9326/291

A moving bed-type suspended solid filtering apparatus, which employs the so-called counter-current method in which raw water containing suspended solid is flown upwardly into the filtering column and the filter material (granular materials like sand) is moved downwardly. The amount of water necessary for the regeneration of the filter material can be small, and the SS concentration in the waste water used for regeneration can be reduced to the order of 1,000 to 3,000 ppm. Water can be fed to the filtering column even during the mid-regeneration, making it possible to collect water almost continuously requiring no spare equipment. Advantages: since the amount of water is 1/30 to 1/100th of the treated water, the size of the waste water treatment equipment can be small. The regenerating frequency of the filter material can be changed according to the SS load. Rapid filtration at a filtering velocity of 20 m/hr is possible. See illustration (9).

**Filtre à sable de type lit mobile pour les solides en suspension** JRDC 9326/291

Dans ce système de filtration dit à contre courant, les eaux brutes contenant les solides en suspension (SS) s'écoulent vers le haut d'une colonne de filtration tandis que le matériau filtrant (semblable à du sable) s'écoule vers le bas. La quantité d'eau nécessaire à la régénération du matériau filtrant reste faible et la concentration de SS dans l'eau de régénération est de l'ordre de 1000 à 3000 ppm. La filtration peut continuer même pendant la régénération, ce qui fait que l'on peut traiter l'eau pratiquement en continu sans matériel de secours. Avantages: La quantité d'eau de régénération n'étant que de 1/30<sup>e</sup> à 1/100<sup>e</sup> de la quantité d'eau traitée, l'appareillage de traitement des eaux de régénération peut être de petite taille. La fréquence de régénération du matériau filtrant peut être adaptée à la charge de SS. la vitesse de filtration peut atteindre 20 m/h. Voir l'illustration (9).

**Separation of Zinc Sulfide Minerals from Complex Sulfide Ore** JRDC 941/291

This technology uses temperature as one of the conditions and performs de-activation of zinc minerals (elimination of copper active film and scavenger) by heating the ore pulp under the condition of sulfurous acid, thereby increasing the floatability of copper minerals for improved separation. Use of this technology makes it possible to eliminate copper by flotation from strongly oxidized zinc concentrates (recovered as floats by the oxidation method; zinc mineral is activated by  $Cu^{++}$  and scavenger and the copper mineral is oxidized and tends not to float), not to mention separation of complex sulfide minerals subjected to oxidation and degeneration.

**Séparation des sulfures de zinc de minerais sulfurés complexes** JRDC 941/291

Dans la présente méthode le conditionnement et la désactivation (élimination du film de cuivre actif et du collecteur) des composés du zinc se font par chauffage de la pulpe en présence d'acide sulfureux. Le traitement augmente la flottabilité des composés du cuivre et améliore la séparation. On peut ainsi séparer par flottation le cuivre des concentrés de zinc fortement oxydés, récupérés à la surface par la méthode d'oxydation (les composés du zinc sont activés par  $Cu^{++}$  et le collecteur, et le cuivre est oxydé et tombe au fond). De plus, le traitement conduit à une meilleure séparation des sulfures complexes soumis à l'oxydation.

**Prefabricated Panel Bridge** JRDC 952/291

The panel bridge can be widely used as an emergency bridge, detour in construction, temporary bridge for carrying heavy equipment or overbridge for a bridge whose yield strength is insufficient for deadweight transportation. The major structure is of the Warren truss type using no vertical members and the effective span can be set with a

**Pont préfabriqué à panneaux** JRDC 952/291

Ce pont à panneaux peut être utilisé comme pont temporaire, en cas d'urgence ou lors de travaux, ou comme renforcement sur un pont trop faible pour le trafic prévu. La structure principale est du type ferme Warren sans membrures verticales et la portée réelle peut être choisie en multiples de deux mètres pour répondre aux conditions du

pitch of two meters according to the local condition and loading conditions. The width can be set within the range from 4 m to 7 m and the bridge can be used either as a deck type or a through type. Panels, floor beams, girders and lateral bracing are connected by means of pins or high tensile bolts without using any special clamping tools. Main girders of 5 m, 4 m and 2 m, can be easily assembled by joining with pins or high tensile bolts.

#### **Window Regulator Handle for Vehicles**

**JRDC 972/291**

The outer surface of the cylindrical projecting portion formed on a main body of a handle and the inner surface of an annular slit formed in a main body of a knob are mutually joined for serving as a bearing. Furthermore, the shoulder portion is joined tightly to the flange portion of the knob to prevent the knob from coming out of the handle. The knob is made of resin and formed in one piece. Since no other component elements are required for bearing and to prevent the knob coming off, the structure is simple and the cost is low.

#### **Pressure Responsive Valve**

**JRDC 976/291**

This technology relates to a pressure responsive valve assembly, provided with a valve member that opens and closes a fluid passage in response to the movement of a power piston that reciprocates by a signaling pressure and the spring force that acts against it. Advantages: the valve member does not adhere to the valve seat, so that the operational responsiveness and durability have been improved; the surface pressure of the valve member to the valve seat can be reduced, with the result that the valve member does not easily wear or deform, and the durability can be improved with no leakage of the fluid, the flow rate can be controlled accurately, and because the movement of the power piston is guided, stable valve operation is ensured.

#### **Canning Method and Apparatus**

**JRDC 9714/291**

This technology relates to a method and apparatus characterized by the capability of canning contents without leaving a head space in the can, while preventing the top and bottom plates from being swollen. Advantages: damage to the can due to excessive filling can be eliminated; since no head space is left, no excessive oxygen is sealed in, protecting the contained foodstuff from deterioration and also preventing corrosion of the inside wall of the can; cans made by this method will not be treated as bulging cans.

#### **Hot-Air Raw Hide Drying Apparatus**

**JRDC 9720/291**

For drying flat materials like cowhide. The raw hides are spread on flat panels which are hung or perpendicularly in-

terrain et aux conditions de charges envisagées. La largeur peut être de 4 m à 7 m et le pont peut être plat ou sous forme de poutre-caisson. Les panneaux, les poutres maîtresses et les poutres de tablier, et le contreventement sont reliés par des broches ou des boulons de haute résistance sans que l'on ait besoin de recourir à des outils spéciaux. Les poutres maîtresses de 5 m, 4 m et 2 m peuvent être facilement assemblées au moyen de broches ou de boulons de haute résistance.

#### **Manivelle de commande des vitres de voiture**

**JRDC 972/291**

La surface extérieure d'une projection cylindrique du bouton de la manivelle et la surface intérieure d'une projection adaptée de la poignée forment un palier de rotation. De plus, la projection cylindrique du bouton porte une collerette qui l'empêche de sortir de son logement une fois qu'on l'y a introduit. Le bouton en plastique est moulé d'une pièce. Comme le système n'exige aucune autre pièce, la manivelle ainsi construite est très bon marché.

#### **Robinet pressostatique**

**JRDC 976/291**

Appareil pressostatique possédant un obturateur qui ouvre et ferme le passage d'un fluide en réponse au mouvement d'un piston de commande dont le déplacement dépend de la pression d'une part et de l'effort de ressorts de rappel d'autre part. Avantages: L'obturateur n'adhère pas au siège, ce qui améliore la réponse et la durabilité; la pression de l'obturateur sur le siège peut être réduite ce qui diminue l'usure et la déformation de l'obturateur et prolonge sa durée de vie. Comme il n'y a pas de fuite de fluide, le débit peut être contrôlé avec précision, et comme le mouvement du piston est guidé, le fonctionnement du robinet est très stable.

#### **Méthode et appareillage de mise en conserve**

**JRDC 9714/291**

Il s'agit d'une méthode et d'un appareillage qui permettent de mettre des aliments en conserve sans laisser d'air dans la boîte et d'empêcher le bombement des extrémités. Avantages: Elimination des dommages dus à un remplissage excessif; en raison de l'absence d'air les aliments sont protégés de toute détérioration et la boîte est protégée de la corrosion; les boîtes remplies selon cette méthode ne présentent pas de bombement.

#### **Appareillage à air chaud de séchage des peaux**

**JRDC 9720/291**

Appareillage pour sécher des matériaux plats comme les peaux de vaches. Les peaux sont étalées sur des panneaux

stalled in parallel and travel in a drying chamber with space between them. This hot air dryer is characterized by gradient velocity distribution such that higher mass velocity of hot air is concentrated on a portion with higher moisture content. Advantages: capability of adjusting the hot air blast according to the moisture content of the raw hide makes the dryness at each portion uniform at the lowest temperature necessary and prevents deterioration of the quality of the hide; the alternately changeable direction of blowing and sucking hot air by each unit prevents only one side of the raw hide from being dried excessively; provision of a uniform sucking unit that converges and sucks hot air blast and regulates its direction ensures effective drying. The suction outlet and blast inlet being connected by means of a duct, with a heat exchanger in between the thermal efficiency, can be improved greatly. See illustration (10).

### **Push-and-pull Ventilation System JRDC 9721/291**

Pollutants in a closed factory or in a sectioned room can be completely exhausted for cleaning without any eddy or air stagnation by a laminar-flow operation of this system. The push-and-pull ventilation system can be effectively used in supplying fresh air to the workers area at all times when pollutants are produced in a wide area of a factory. The shutoff push-and-pull ventilation (called air shutter) is also very effective for shutting off an area where pollutants are produced from the workers' breathing area, by catching, converging and discharging the pollutants without diffusing them. This air shutter ensures a uniform air current of a fixed velocity distribution and discharges pollutants without leakage outside the air current.

### **Incinerator for Burning Refuse in Containers JRDC 9722/291**

Industrial refuse difficult to be handled, such as sticky materials, solid resins, rubber materials, etc., is put into open top containers which are mounted on a plate, which prevents the furnace floor from being soiled due to overflow, and which helps to position the container opening with respect to the water-cooled nozzle and to bring the containers in and out of the furnace. After kindled by burners, the refuse is supplied with jet air through the water-cooled nozzles and is completely burned. Advantages: energy-saving incineration; external heating time is short; heat recovery is possible; industrial refuse difficult to be handled can be incinerated simply and perfectly. Example: The air blast speed from the water-cooled nozzle was set to 0.3 m<sup>3</sup>/min. Eight iron drum cans with each one having an opening on the top were filled with sticky synthetic resin refuse, 140 kg per can, and were loaded into the incinerator. After five days of incineration, refuse equivalent to 120 drum cans were burned. The fuel oil consumption was 40 lit/hour on the average.

qui sont suspendus en parallèle et se déplacent dans une enceinte de séchage sans jamais se toucher. Ce séchoir à air chaud est caractérisé par un gradient de vitesses tel qu'une plus grande quantité d'air chaud est concentrée sur une région où la teneur en humidité est plus élevée. Avantages: Possibilité de régler le débit d'air chaud en fonction de la teneur en eau des peaux, ce qui fait que l'on obtient un degré de sécheresse uniforme à la plus basse température possible, évitant ainsi toute perte de qualité; le changement de direction de l'aspiration et de la soufflerie d'air chaud pour chaque section empêche que la peau ne sèche d'un côté de façon excessive; l'existence d'un système d'aspiration uniforme qui concentre et aspire l'air chaud et contrôle sa direction pour obtenir un séchage efficace. La sortie de l'aspiration et l'entrée d'air chaud sont reliées par un conduit qui contient un échangeur de chaleur pour améliorer l'efficacité thermique. Voir l'illustration (10).

### **Système de ventilation JRDC 9721/291**

Les polluants d'une usine ou d'un secteur fermé peuvent être complètement extraits, pour les éliminer, sans tourbillons ni stagnation de l'air par l'écoulement laminaire que produit ce système. Il peut être utilisé pour amener de l'air frais aux zones de travail, même lorsque des polluants sont produits dans une vaste zone de l'usine. Le mécanisme de fermeture de la ventilation (appelé rideau d'air) est également très efficace pour isoler une zone de production de polluants de la zone où les travailleurs respirent, du fait qu'il capture, concentre et décharge les polluants sans les diffuser. Le rideau d'air permet un courant d'air uniforme circulant à une vitesse fixée et la décharge des polluants sans fuite extérieure d'air.

### **Incinérateur de déchets dans des conteneurs JRDC 9722/291**

Les déchets industriels dont la manutention est difficile, comme les produits collants, les résines solides, les produits caoutchoutés, etc., sont placés dans des conteneurs ouverts en haut. Ces conteneurs sont placés sur une plaque qui empêche de salir le fond du four, permet le positionnement des conteneurs sous les jets d'air refroidis par eau, et permet également l'enfournement et le défournement. Après allumage par des brûleurs, le produit est alimenté en air de combustion par les jets d'air mentionnés, jusqu'à combustion complète. Avantages: Incinération économique du point de vue énergétique; durée de chauffage extérieur courte; récupération de la chaleur possible; incinération simple et parfaite des déchets industriels difficiles à manipuler. Exemple: La vitesse de l'air aux jets refroidis par eau a été réglée à 0,3 m<sup>3</sup>/min; huit barils ouverts en haut ont été remplis de déchets de résine synthétique collante (140 kg par baril) et introduits dans l'incinérateur. Après cinq jours d'incinération on avait brûlé l'équivalent de 120 barils. La consommation d'huile avait été en moyenne de 40 L/h.

**PIF Surface Acoustic Wave  
Filter on LiTaO<sub>3</sub>**

**JRDC 987/291**

In recent years, the practical application of surface acoustic wave filter to various fields such as PIF filter for television receivers has rapidly progressed. When a 112° Y direction of propagation is selected, the X cut plate of LiTaO<sub>3</sub> shows the following superior characteristics as material for surface acoustic wave devices: (1) Low frequency temperature coefficient of -18 ppm/°C (2) Low bulk spurious level. (3) High reproducibility and reliability with characteristics variation within ±0.06% and time change after 10,000 hours within ±0.025%. (4) Superior electro-mechanical coupling factor  $k^2$ : 0.8%. In addition, our newly developed optimum control of temperature distribution in a furnace for crystal growth and our economical crystal growth technology have made it possible to realize the mass production of low-cost LiTaO<sub>3</sub> single crystals with such a large diameter as 6.25 cm.

**Sheath Current Reducing  
Bonding Circuit**

**JRDC 989/291**

This technology relates to a bonding circuit in which a saturable reactor is connected to the cross bonding wire in series and the protective device for corrosion preventing layers are connected to the connecting points of these reactors. This technology considerably reduces the sheath current in normal operation by suppressing it by saturable reactors, and if a great current like a fault current flows, the saturable reactors are saturated and reduce the impedance of the sheath circuit, thereby the fault current returning through the sheath circuit. If the surge voltage moves in, the protective device for corrosion preventing layers operates to bypass the voltage to the ground. The sheath current in normal operation being reduced to 1/10 to 1/20 that in the conventional system, the heating of the cable sheath is inhibited and the power loss caused by the cable sheath can be reduced. Furthermore, the transmission capacity can be increased by approximately 10%. The sheath serves as a return circuit against a fault current, so that it flows to the ground and does not cause inductive interference to nearby communication lines.

**Pulse-Type Level Detector**

**JRDC 9811/291**

This technology relates to a level detector designed to detect process materials in a tank, bin, hopper or pipe. Advantages: the detecting section has no protrusions and can be installed flush with the inner surface of a tank; since the detector is not subject to a load due to the flow of the contents, it cannot suffer any damage or malfunction; detection is not affected by the build-up of powder, granules, or viscous liquids on the sensing disc. See illustration (11).

**Filtere de fréquence intermédiaire  
d'image à onde acoustique de surface sur LiTaO<sub>3</sub>**

**JRDC 987/291**

Au cours des dernières années, les applications des filtres à onde acoustique de surface ont progressé rapidement et ils sont maintenant utilisés, par exemple, dans les récepteurs de télévision. Lorsque l'on choisit une direction de propagation de 112° par rapport à Y, la lame de LiTaO<sub>3</sub> de coupe X présente des caractéristiques supérieures comme matériau pour les ondes acoustiques de surface, notamment: (1) Faible coefficient de température de la fréquence, -18 ppm/°C. (2) Faible niveau de réponses parasites. (3) Reproductibilité et fiabilité élevées, les caractéristiques de variation étant de ±0,06% et le changement au cours du temps de ±0,025% après 10 000 heures. (4) Facteur de couplage électro-mécanique supérieur,  $k^2 = 0,8\%$ . De plus, notre nouveau système de contrôle de la distribution des températures du four et notre technique économique de production des cristaux nous permet de réaliser une production de masse de cristaux uniques de LiTaO<sub>3</sub> bon marché et pouvant atteindre 6,25 cm de diamètre.

**Circuit de couplage pour  
réduire les courants de gaine**

**JRDC 989/291**

Normalement, les gaines métalliques des câbles de lignes électriques sont reliés entre elles pour réduire les courants de gaine, mais il reste toujours un courant assez important. Le présent système contient dans le circuit de couplage des gaines un réacteur saturable en série et un dispositif de protection contre la corrosion aux points de connexion de ces réacteurs. Cet arrangement permet de réduire considérablement le courant dans les gaines en fonctionnement normal, en le supprimant au moyen des réacteurs saturables. En cas d'élévation importante du courant, les réacteurs se saturent et réduisent l'impédance du circuit de gaine, ce qui fait que le courant retourne par le circuit de gaine. En cas de saute de courant, le dispositif de protection fonctionne en dérivation et conduit le courant à la terre. En fonctionnement normal le courant de gaine se trouve réduit au 1/10<sup>e</sup> à 1/20<sup>e</sup> du courant des systèmes habituels, l'échauffement de la gaine est moindre et la perte de puissance beaucoup plus faible. De plus, la capacité de transmission peut être accrue de 10%. La gaine sert de circuit de retour en cas d'élévation importante du courant, de sorte que celui-ci s'écoule vers la terre et ne cause pas d'interférences inductives avec les lignes de communication voisines.

**Détecteur de niveau à impulsions**

**JRDC 9811/291**

Détecteur conçu pour mesurer la quantité de produit dans un réservoir, un bac, une trémie ou une conduite. Avantages: La section de détection ne dépasse pas et peut-être installée dans le plan de la surface intérieure du réservoir; le détecteur n'étant soumis à aucune charge, il ne peut être endommagé par le courant ou les produits; la mesure n'est pas affectée par les accumulations de poudres, de granules ou de liquides visqueux sur le senseur. Voir l'illustration. (11)

**Automatic Vehicle Identification System JRDC 9812/291**

This system, which automatically reads the vehicle numbers and other necessary data from traveling vehicles, can be applied to highway traffic control systems; area license systems; weigh-in-motion applications; automatic billing systems; automatic gate control and warning systems; container identification systems and, automatic car identification systems. The transponder dispenses with any form of power source; is easily mountable on any vehicle; it offers high reliability; has exceptionally long service life; has a large information capacity of up to decimal 12 digits; reads data during inclement weather (snow or rain) or even when the transponder is extremely soiled; and, being provided with a multichannel function, the interrogator is capable of simultaneously reading data from numbers of oncoming vehicles on different lanes.

---

---

**NOTICE**

---

---

**Reference Manual on Doing Business in Latin America**

Price: U.S. \$20.00 soft-cover, U.S. \$30.00 hard-cover. A basic guide for lawyers and business executives involved in international business transactions in Latin America. It identifies the best sources of information, reference data, analytical materials, reports and consultative sources to assist practitioners be successful in this field. Advice and a checklist for investors is included along with the following

**Système d'identification automatique des véhicules JRDC 9812/291**

Ce système qui permet de lire automatiquement le numéro d'identification ou toute autre information concernant des véhicules en mouvement, peut être appliqué aux systèmes de régulation de la circulation; aux systèmes d'immatriculation par zone; au pesage en mouvement; à la facturation automatique; à la commande automatique des portes; à l'identification des charges et bien entendu à l'identification automatique des véhicules. Le transpondeur n'a besoin d'aucune source d'énergie, il se monte facilement sur les véhicules, il est très fiable, il a une durée de vie exceptionnelle, il a une capacité pouvant atteindre 12 chiffres; et il n'est pas affecté par le temps (pluie ou neige) ni la saleté. Enfin, si l'interrogateur dispose de plusieurs canaux, il peut lire simultanément les données des véhicules arrivant sur différentes files.

select aspects of Doing Business in Latin America: cross-cultural dimensions, negotiating, arbitration, joint ventures, investment, contract guarantees, the role of Latin American private capital and services provided by government and private organizations. Available from: The Center for Latin America, The University of Wisconsin-Milwaukee, P.O. Box 413, Milwaukee, Wisconsin 53201.

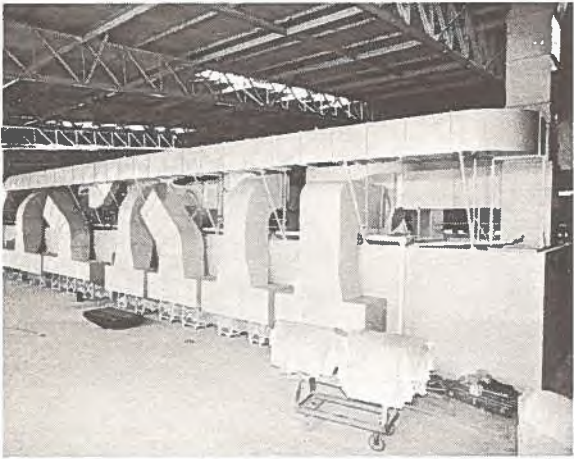

(10) Hot-Air Raw Hide Drying Apparatus  
(10) Appareillage à air chaud de séchage des peaux

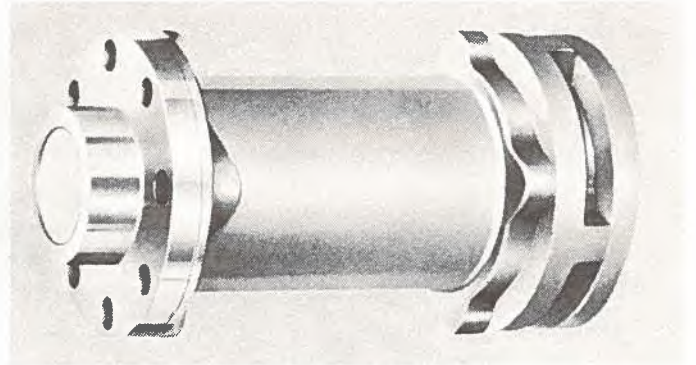

(11) Pulse-Type Level Detector  
(11) Détecteur de niveau à impulsions



(2) Exterior Wall Insulation System  
(2) Système d'isolation des murs extérieurs

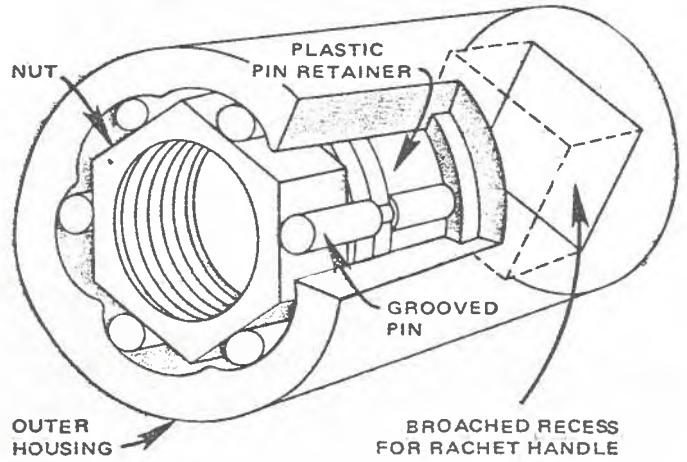

(7) Adjustable Gripping Socket  
(7) Douille de serrage réglable



(1) Aerial Self-Propelling Conveyor Device  
(1) Transporteur-tracteur aérien automoteur

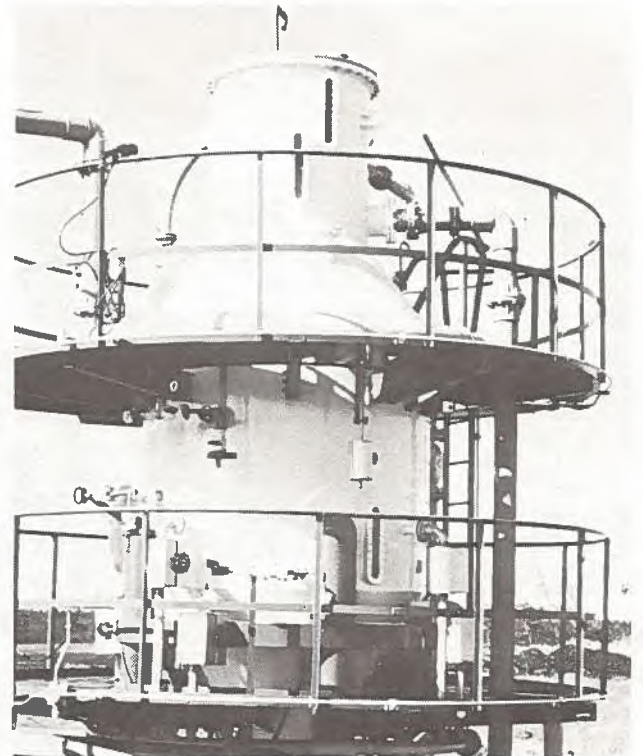

(9) Moving Bed-Type Sand Filter for Suspended Solid  
(9) Filtre à sable de type lit mobile pour les solides en suspension



(3) Mini Bob  
(3) Mini-bob

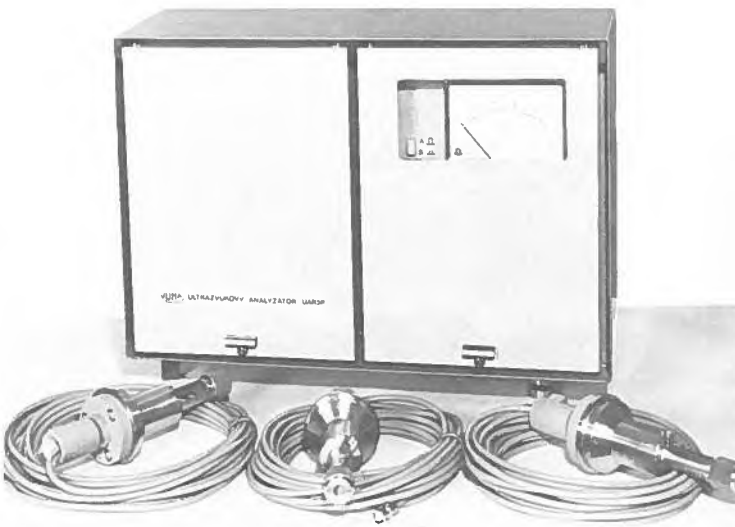

(8) Ultrasound Liquid Analyser UAR-3  
(8) Analyseur de liquide par ultrasons UAR-3



(6) Outerwear  
(6) Vêtements de dessus

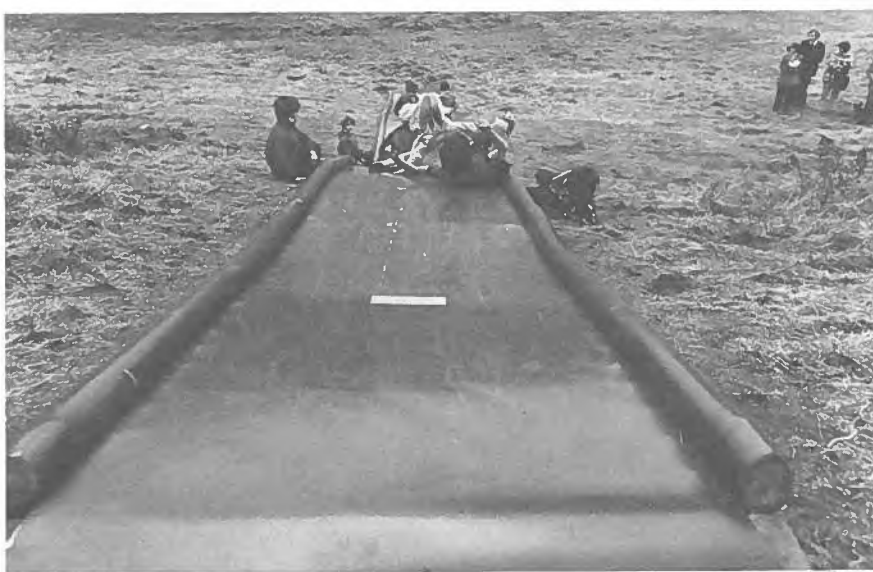

(5) Safe Slide  
(5) Toboggan sécuritaire



(4) Pocket-Size Fire Escape and Rescue Device  
(4) Descendeur de secours portatif