



Archived Content

Information identified as archived is provided for reference, research or recordkeeping purposes. It is not subject to the Government of Canada Web Standards and has not been altered or updated since it was archived. Some of this archived content is available only in one official language. Translation by CMHC can be requested and will be provided if demand is sufficient.

Contenu archivé

Le contenu identifié comme archivé est fourni à des fins de référence, de recherche ou de tenue des dossiers; il n'est pas assujéti aux normes Web du gouvernement du Canada. Aucune modification ou mise à jour n'y a été apportée depuis son archivage. Une partie du contenu archivé n'existe que dans une seule des langues officielles. La SCHL en fera la traduction dans l'autre langue officielle si la demande est suffisante.

A LOW INCOME
HOUSING POLICY
FOR 1971.

**housing for
native people**

A LOW INCOME HOUSING POLICY FOR 1971
BACKGROUND PAPER

HOUSING FOR NATIVE PEOPLE

G. RHEAUME,
C.D. CRENNÀ,

POLICY PLANNING GROUP

DECEMBER, 1970.

CONTENTS

- I. INTRODUCTION - THE GENERAL CONDITIONS
OF NATIVE PEOPLE IN CANADA

 - II. PREVIOUS DEVELOPMENTS IN THE FIELD OF
HOUSING FOR NATIVE PEOPLE

 - III. POLICY VARIABLES

 - IV. VIABLE POLICY OPTIONS

 - V. THE BROADER CONTEXT - HOUSING AND NATIVE
SOCIAL DEVELOPMENT
-
- APPENDIX A - RESULTS OF A SURVEY CONDUCTED
BY THE METIS NATION OF
SASKATCHEWAN

 - APPENDIX B - EXCERPTS FROM KENNEDY/SMITH
ASSOCIATES HOUSING STUDY OF
ISOLATED COMMUNITIES AND
INDIAN RESERVES IN THE
PRAIRIE PROVINCES

I. INTRODUCTION - THE GENERAL CONDITIONS OF NATIVE PEOPLE IN CANADA

There are an estimated 500,000 Canadians of native descent, and they live in all parts of the country.^{1.}

The three main sub-groups of this population are:

Eskimos	16,000
Indians	245,000
Metis, Non-Status Indians	240,000

For administrative purposes the Eskimos and Indians are the responsibility of the Federal government, mainly through its Department of Indian Affairs and Northern Development. All other people of native descent are under the jurisdiction of the provincial or territorial governments of the regions in which they reside. In theory, they have all the rights, privileges and opportunities available to other Canadians, but in fact, they have consistently remained outside the mainstream of Canadian society.

Every major study of native problems in Canada over the past fifteen years has clearly described the generally appalling conditions of poverty and dependency in which native Canadians are to be found. Their situation is one characterized by substandard housing, chronic unemployment, ill health, inadequate or non-existent public services, low educational opportunity, alienation, apathy, alcoholism and crime. The latter is periodically dramatized by a frontier mass murder as shocking as any committed in large American cities.

On the following pages statistics for Manitoba reserves serve to illustrate two of the acute socio-economic problems mentioned above - unemployment and welfare dependency.^{2.}

-
1. Accurate statistics on native people, especially on Metis, are not available.
 2. For the study "transitional" reserves were defined as those accessible by rail and/or road, but outside the dominant agricultural areas. "Isolated" reserves are those accessible only by air and/or water.

Percentage of permanent employed on the reserve (as ^{1.}
compared to the total population on the reserve

A. Transitional Reserves

	Dist. in miles (approx.)	1967/68	1968/69
Brokenhead	42	27.3	8.4
Fort Alexander	68	3.4	3.6
Little Black River	100	0.7	0.7
Sandy Bay	102	0.7	0.6
Lake Manitoba	104	0.7	0.2
Peguis	116	2.9	3.1
Fisher River	123	1.3	1.3
Hollow Water	126	2.6	1.2
Ebb & Flow	133	0.5	0.5
Fairford	136	2.1	1.9
Lake St. Martin	148	3.0	2.0
Jackhead	157	0.0	0.4
Little Saskatchewan	162	4.8	4.7
Rolling River	164	2.0	-
Crane River	176	1.6	1.6
Keeseekowenin	179	2.7	2.4
Birdtail Sioux	198	4.6	-
Waywayseecappo	201	0.9	-
Waterhen	235	1.2	1.2
Valley River	246	3.4	3.4
Grand Rapids	259	1.7	2.0
Chemahawin	277	16.1	17.5
Pine Creek	277	2.8	2.8
Shoal River	385	1.3	-
The Pas	425	3.7	4.1
Mathias Colomb	650	1.5	1.7
Fox Lake	900	21.5	16.6
Churchill	1100	8.5	6.2
Average		4.41	3.67

L. P. Degrez and G. Sigurdson, The Economic Status of the Canadian Indian: A Re-examination, (Winnipeg, 1969), p. 23

B. Isolated Reserves^{1.}

	Dist. in miles (approx.)	1967/68	1968/69
Moose Lake	40	0.8	0.9
Nelson House	60	1.3	2.2
Split Lake	62	9.3	8.8
Cross Lake	70	-	-
Oxford House	120	3.3	2.9
Bloodvein	125	0.3	0.6
Little Grand Rapids	140	0.5	0.5
God's Lake	140	1.1	1.4
Berens River	165	2.7	2.5
Island Lake	165	1.2	1.3
Barren Land	200	0.0	0.0
Shamattawa	200	5.3	5.0
Poplar River	210	-	-
York Factory	240	23.5	30.3
Norway House	310	-	-
Average		4.16	4.74

1. Ibid., p. 24

Percentage of people residing on reserve receiving ^{1.}
welfare allowance

A. Transitional Reserves

	Dist. in miles (approx.)	1967/68	1968/69
Brokenhead	42	34.6	36.7
Fort Alexander	68	53.9	33.5
Little Black River	100	67.4	67.1
Sandy Bay	102	63.8	67.6
Lake Manitoba	104	51.9	40.1
Peguis	116	7.8	17.2
Fisher River	123	25.4	26.6
Hollow Water	126	50.5	73.8
Ebb & Flow	133	90.1	88.8
Fairford	136	57.7	48.9
Lake St. Martin	148	36.7	38.3
Jackhead	157	34.4	44.8
Little Saskatchewan	162	44.9	44.0
Rolling River	164	35.1	-
Crane River	176	14.8	69.4
Keeseekowenin	179	-	51.0
Birdtail Sioux	198	10.7	-
Waywayseecappo	201	21.2	-
Waterhen	235	65.6	71.4
Valley River	246	63.3	63.3
Grand Rapids	259	39.2	59.2
Chemahawin	277	14.1	84.1
Pine Creek	277	53.5	53.5
Shoal River	385	23.8	-
The Pas	425	29.7	22.0
Mathias Colomb	650	15.3	26.0
Fox Lake	900	18.9	34.0
Churchill	1100	11.9	45.0
Average		38.3	50.2

^{1.} Ibid., p. 25

B. Isolated Reserves ^{1.}

	Dist. in miles (approx.)	1967/68	1968/69
Moose Lake	40	83.5	100.0
Nelson House	60	30.8	93.5
Split Lake	62	26.5	65.4
Cross Lake	70	-	-
Oxford House	120	-	37.4
Bloodvein	125	17.8	19.6
Little Grand Rapids	140	13.4	13.8
God's Lake	140	44.0	69.2
Berens River	165	17.0	16.8
Island Lake	165	9.8	21.5
Barren Land	200	7.1	81.7
Shamattawa	200	81.2	80.9
Poplar River	210	-	-
York Factory	240	60.5	87.8
Norway House	310	-	-
Average		35.6	57.3

1. Ibid., p. 26

These are two sides of the same coin and the result of cultural disintegration and the ecological effects of "development".

To the list of obstacles faced by native people in their search for identity, dignity, and the basic essentials of life, must be added the widespread though seldom acknowledged racial discrimination against them by whites.

In more northerly communities and in centres with relatively large native populations such discrimination has usually hardened into a part of the status structure, and in some cases the power structure of the locality concerned. Thus the efforts of native people to change their lot meet with active opposition from some quarters - from those who would lose by the breakdown of dependency.

One indicator of the "structure" of the situation in which native people find themselves is residential segregation. In Appendix "B", site diagrams of several communities prepared by Kennedy/Smith Associates for an excellent CMHC sponsored report have been reproduced. These clearly illustrate the centre and periphery nature of native settlement. They also show some segregation among native people themselves whether for historical or other reasons.

General programs available to the public have proven largely unsuitable for native people. Even those programs directed to their special problems have been ineffective, sometimes counter-effective.

Unfortunately, the gap between most native people and the rest of Canadian society appears to be widening. It seems likely that their problems will magnify and intensify during the next decade due to a combination of the following factors:

- (1) 50% are under 16 years of age
- (2) their birth rate is 3 times the national average
- (3) their level of expectations is increasing rapidly

Compounding the problem of providing suitable programs and services to them is the fact that Canadian native people are in a state of tremendous transition which is neither smooth nor uniform. Individuals and groups of natives are encountering and responding to these transitional forces in different ways and to different degrees. Thus there can be no "single solution" because there is no single native problem. The widespread failure of past government programs seems to stem not only from inadequate levels of expenditure but also inflexibility of approach and response to different groups with different kinds and levels of need.

None of this is new in the sense that it has been stated many times over the past years by a wide range of concerned Canadians. Two developing trends, however, can be detected that bear significantly and directly on this situation.

1. There is a growing recognition by all levels of government that native problems have reached crisis proportions and that the programs and policies of the past have not only failed to meet the needs of the native people but may have inadvertently contributed to the problem by their irrelevance. This awareness by governments is coupled with uncertainty and confusion as to what should be done, how it should be done and by whom it should be done, but on one point there is general agreement: immediate action is required!

There is a parallel and rapid growth of awareness by native people that they have been excluded and that they must take all necessary steps to obtain redress. Native organizations at the local, provincial and national levels are developing quickly with leadership that is articulate about their frustrations and their right to work out their own solutions.¹ These groups and their leaders are looking to governments for financial assistance to make their organizations viable as the first step in planning and controlling their own programs. For

1. See for example the number of grant requests listed on page 13 below.

the most part, they are willing to be patient if they are allowed to obtain this kind of involvement. There is strong pressure, however, particularly from the younger elements in these organizations, to be much more militant and aggressive in pursuit of their objectives. To that extent, non-violence must be viewed as an interim tactic to bring about change.

II. PREVIOUS DEVELOPMENTS IN THE FIELD OF HOUSING FOR NATIVE PEOPLE

In this section of the paper, the various presently available programs for native people will be outlined. While some critical comments are made on these in passing, general discussion of native housing problems is reserved for the subsequent section on "Policy Variables".

A. INDIANS

There are four special programs through which Indian people may obtain housing. Three of these operate only on Indian reservations while the fourth is available to Indian people living off reservations. A brief description follows:

(1) Subsidy Housing Program

Under this program, Indian people living on reservations can acquire housing that is highly subsidized by direct grants through departmental funds. The maximum subsidy is \$8,500.00 per family and the minimum contribution in the form of cash, labour or materials is \$135.00 for those families with less than \$3,000.00 per year annual income. Under a parallel program, a furniture subsidy up to a maximum of \$1,000.00 is available. About 75% of all Indian families earn less than \$3,000.00 per annum, with fully 60% earning \$2,000.00 per annum or less.

The volume of housing built under this program has failed to correct the backlog of need and has fallen short of meeting the requirements of new family formations. This is revealed by the statistics that indicate that in

1965, a backlog of some 6,000 houses existed. In the following five years, approximately 7,000 new units were constructed but the backlog had increased to some 8,500 units by the end of 1969. It is obvious from this that a successful program for Indian housing must involve greatly increased expenditures if it is to have a noticeable effect on housing conditions. Translated into a five year program, the minimum requirements would be of a magnitude in excess of 3,500 units per year. Concurrently, a greatly increased home repair program would be needed to rehabilitate some 7,500 Indian houses that, with renovation, could provide decent shelter.

(2) Band Administered Programs

Essentially this is an extension of the subsidy housing scheme, the main difference being that band councils administer the program themselves. We have not analyzed the results carefully or made direct contact with those Indian bands (about 30) which currently operate their own programs. To date, only about 200 houses per year have been built in this way but the department hopes to greatly expand the volume over the next five years.

There are several apparent drawbacks to the program as it is presently constituted:

1. Many Indian bands are reluctant to embark on it because they suspect that it may be part of a major plan for Indian Affairs to withdraw services or to shift them to other agencies.

2. Many bands lack the administrative experience at this point to take on total responsibility for their own housing. A complementary training program is needed along with administrative support to allow bands to develop the necessary experience and expertise.

3. Greater flexibility in terms of housing standards and design should be possible to give Indian bands a wide range of housing options under the program.

This program should be more closely assessed.

With modification, it may well prove to be the best way to provide housing to all those bands ready to assume greater control of their own affairs.

(3) CMHC Loans

Under this program, money is available to Indians on reservations in the form of a first mortgage loan through CMHC or other approved lenders with repayment guaranteed by the department in the event of default by the borrower. The individual is limited by his own financial resources and his ability to meet monthly payments. In the past four years, less than 200 such loans have been made under this scheme.

(4) CMHC and DIAND Loans

Under this program, Indians who are regularly employed off reserves, who can guarantee that their employment is of continuing nature, who have a good credit rating and a good "responsibility record" may obtain a first mortgage through CMHC or an approved lender, and a second mortgage from DIAND. If, during the first 10 years, the individual meets his payments, the department can fully forgive the second mortgage. However, the bulk of the Indian people living away from Indian reservations cannot meet the financial criteria for the program.

Furthermore, the program appears to be administratively cumbersome: initial application is made to the Indian Affairs Department, processing is carried out by the Department of Veterans Affairs, and financing is carried out by CMHC. It can remain a limited resource to those few Indians who obtain and retain steady employment away from their reservations. Less than 300 such loans have actually been made since the program started in May of 1967. The chart on the following page gives specific, although not necessarily accurate, figures on this program to March 31, 1970.

INDIAN OFF-RESERVE HOUSING PROGRAMME¹.

DECEMBER 31, 1969

DIA & ND APPROVALS	314
CMHC MORTGAGES (received from Branches)	233
ARREARS (from CMHC 174 and Branches)	26
PERCENTAGE IN ARREARS	11.1

MARCH 31, 1970

DIA & ND APPROVALS	414
CMHC MORTGAGES - STATISTICAL DIVISION	123 (February 15, 1970)
- COMPUTER (CODE 040)	137
ARREARS (from CMHC 174)	22 (April 30, 1970)
PERCENTAGE IN ARREARS	9.44 (taken from 233 Mortgages)

*Figures are taken from available information and are not necessarily exact.

1. M. West, A Study of the Indian Off-Reserve Housing Programme,
Advisory Group, CMHC, 1970.

B. METIS

Only the three Prairie provinces make special arrangements to house Metis families in remote and isolated areas. These programs consist of subsidized home ownership schemes designed to provide very modest accomodation and operated under Section 35A, NHA. Since 1965, when the program was initiated in Saskatchewan (it was extended to Manitoba in 1969 and Alberta in 1970), less than 500 units in all have been built.

These programs have been experimental in nature, and many factors have contributed to their failure as an experiment. In the first place, the volume was so modest as to make no detectable impact on the housing conditions of the Metis people. Secondly, while the original plan envisaged close cooperation between the Metis and the provincial housing authorities in the operation of the program, this arrangement broke down almost immediately and the native people have taken little part in it.

The complaints listed by the Indian people in relation to their housing programs are echoed by the Metis people in these three provinces. There is evidence that serious collection problems have built up and the whole future of the programs seems in some doubt.

C. ESKIMOS

Since 1965, the Department of Northern Development has operated a substantial housing program for Eskimo people and while it has not met the total requirement, it has achieved relatively greater success than have programs for the other native groups. A striking factor in this success seems to have been the great degree to which the Eskimo people participated in their own program. Local Eskimo housing councils were established whose function was to allocate and administer the program on a continuing basis. A comprehensive program of economic counselling and social orientation was developed as the integral part of the

program. This program has not been directly analyzed to date, but departmental reports and limited contact with territorial officials suggest that this program was far superior to any others yet devised.

D. RECENT DEVELOPMENTS

During 1970, several provincial native organizations have undertaken an assessment of their own housing problems, after obtaining a grant under the Part V program. Only one of these studies has been completed, that done by the Metis Society of Saskatchewan, which documented the desperate housing conditions of the Metis people in that province, and suggested an initial housing project for their older people. Other grants have been approved and studies are in progress as follows:

<u>Organization</u>	<u>Grant</u>	<u>Purpose</u>
Alberta Indian Association	\$30,000.00	Housing problems of native people in Edmonton
Manitoba Indian Brotherhood	\$20,000.00	Housing problems of Indian people in Winnipeg
Union of Ontario Indians	\$20,000.00	Housing problems of Indians migrating to Toronto
Yukon Native Brotherhood	\$35,500.00	Migration patterns and housing for Yukon natives

In addition to these approved grants, requests have been received, and are being processed from the following native organizations:

Manitoba Metis Federation	\$39,600.00	Housing programs for Metis in Manitoba
Alberta Metis Association	\$50,000.00	Housing needs for Metis in Alberta
Union of New Brunswick Indians	\$34,000.00	"Task Force" study of Indian housing in N.B.
Union of Nova Scotia Indians	\$20,000.00	Housing for Nova Scotia Indians
B.C. Association of Non-Status Indians	-	A housing project for B.C. natives

Discussions with the Alberta Indian Association indicate that a request for funds will be forthcoming from them for further studies after they complete their current survey (Target Date: March, 1971).

A brief examination of the current surveys indicates several common patterns of operation:

1. Native fieldworkers are hired to gather basic data.
2. Consultants are retained to devise the research scheme and to analyze the findings.
3. A general housing meeting is called, with delegates attending from various "locals" to review the findings.
4. Recommendations are made by the association to the appropriate authorities.

These Part V grants appear to have been invaluable in terms of involving the native people in attempts to resolve their housing problems. There is a serious lack of data on such things as migration patterns, income levels, and consumer aspirations of native people, and these studies can serve to obtain this information. Of greater importance, the provision of funds for housing surveys allows the native people an opportunity to plan and implement a research program from their point of view, using their own people - this process itself is highly educative and is an essential step toward greater self-determination for these groups.

III. POLICY VARIABLES

On the next page, an attempt has been made to chart some of the relationships between the immediate factors contributing to the social and housing problems of native people and more general developments in Canadian society. The diagram does not constitute a "policy model" in the sense of a theory or concept which would allow us to project alternative problem futures and devise viable policy approaches.

A ROUGH MODEL OF THE
EVOLVING HOUSING NEEDS OF NATIVE PEOPLE

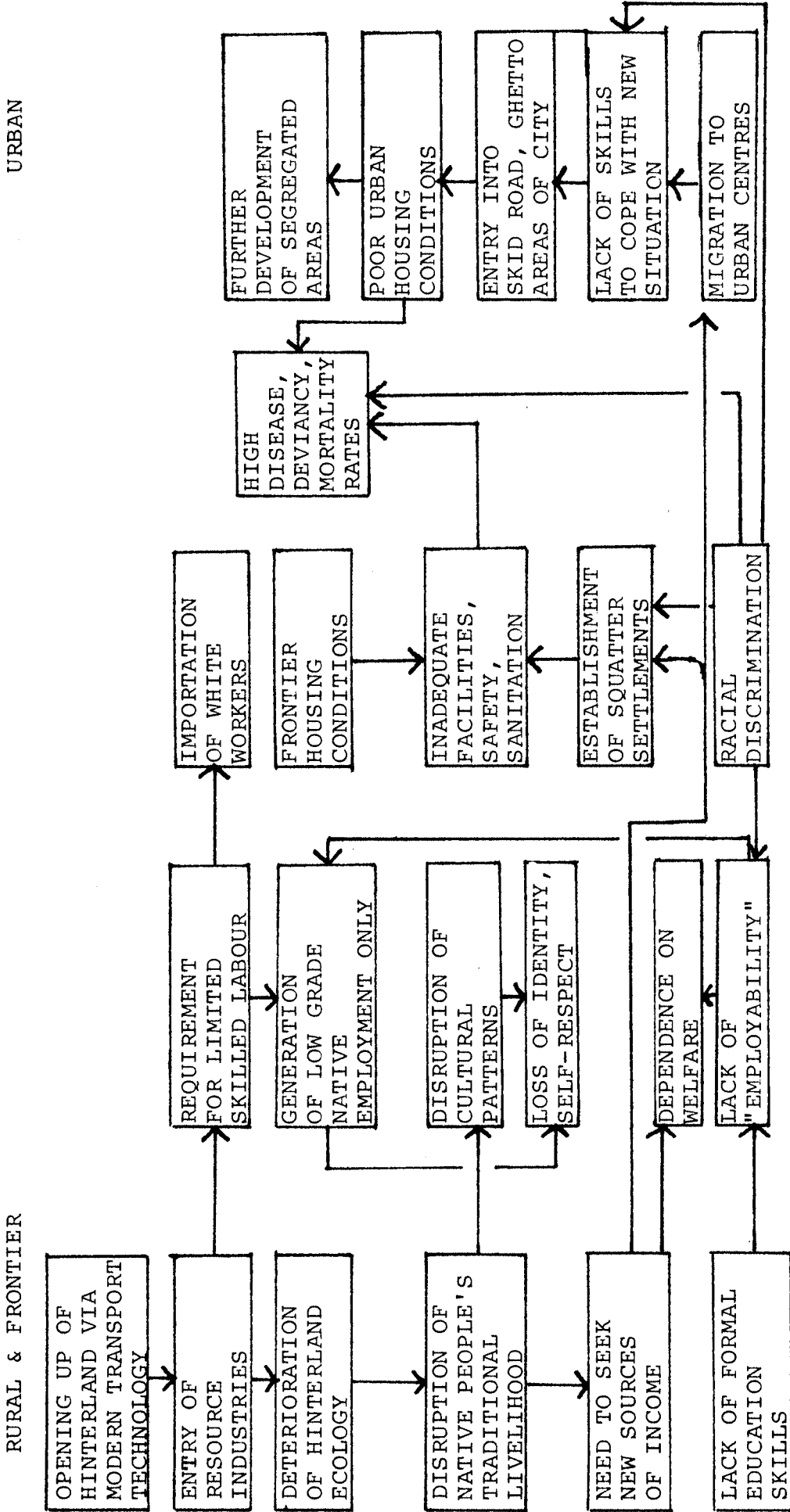

It does however emphasize that the problems of native people are structural as well as cultural and individual. That is, many matters are beyond the control of native people themselves to substantially alter and they are inherent in the overall approaches to resource development, metropolitan-hinterland relations, and social status to be found in Canada.

A. HOUSING CONDITIONS

Housing conditions are a result of the frontier economy and social structure as well as the product of its technology, building skills and materials.¹

However, it also would seem that housing conditions are a key "leverage point" in the evolving situation of Canada's native people. That is, action directed to solving the housing problems could have considerably more far-reaching effects than the actual production involved would indicate:

Nearly every native organization in Canada has identified inadequate housing as a number one priority for action. They see their shelter conditions as a primary obstacle to the optimal use of other programs for educational, health, economic, social and cultural upgrading. Indeed, without decent housing, millions of dollars spent annually by government agencies on other programs are wasted.

B. HOUSING AND HEALTH

Indian and Northern Health Services (a federal government health service) has spent more than \$30 million each year for the past ten years to combat illness among the Indians and Eskimos. Inadequate housing has been diagnosed as the greatest health hazard these people face, but only a fraction of that amount is budgeted by the federal authorities to improve the housing conditions.

C. PROGRAM ADMINISTRATION

Many examples could be provided reflecting the lack of an integrated, co-ordinated approach by various federal agencies to the problem of housing Canadian Indian and Eskimo people, as a pre-requisite to raising their standard of living.

1. See Appendix A for results of a survey of conditions conducted by the Saskatchewan Metis Society.

A similar situation prevails within provincial jurisdictions in relation to programs and services to Metis and other native people. The net effect of all this is a hodge-podge of disparate, often conflicting, programs that create administrative inefficiency and a frightening waste of desperately needed housing funds.

D. NATIVE PARTICIPATION

We have said that past housing programs have been inadequate in volume and inflexible in scope. Lack of co-ordination and integration with other related programs has further diminished their effectiveness in improving the lot of the native people. To these shortcomings must be added the consistent failure of housing authorities to involve the native people themselves in these programs. Until recently, the involvement of native people in their own affairs was seldom considered necessary and the history of these special housing programs reflects this attitude. This has led, we believe, to the widespread, almost universal, rejection by the native people of these programs, which they consider to be irrelevant to their real needs as they perceive them. There is ample evidence to support their contention that past programs were grossly unsuitable.

Flowing from this lack of participation by the native people are the following common complaints:

1. Housing has been planned without reference to the wishes or needs of the occupants in terms of family size, economic status or life-style.
2. Few native people, including those with construction skills, obtained employment during the construction phase.
3. Houses were badly built, of substandard materials and occasionally left unfinished.
4. Little use was made of local materials even when they were suitable and readily available.

5. Housing was often located on unsuitable sites or in places where the people did not want to live.

6. Housing allocation was done by local committees or government officials without following consistent or known procedures. This created grave and lasting dissension among the people, particularly since so few units were available in relation to the need.

7. Few native people could obtain essential furnishings to make good use of new, usually larger housing. Cook stoves, refrigerators, washing machines, beds, tables and chairs, cooking utensils were generally needed, and not available. In some extreme cases, families occupied new housing that had no heating units.

8. Many native people did not understand the financial obligations of the housing program and were unable to meet the requirements of monthly payments. For others, unemployment or a reduction in usual income made it impossible for them to do so.

9. Few native families could afford, or saw the need for, regular maintenance to keep their home in livable condition.

10. Many native people simply lacked the basic living skills to successfully cope with the demands of operating a new home with new (to them) services such as sewer, water and electricity.

It should be pointed out for purposes of balance that a substantial number of native families appeared to lack both initiative and motivation to upgrade their housing and did not take even minimal steps to look after their units. These places have rapidly deteriorated and a substantial number will soon be unfit for habitation. They will have to be replaced within the next five years even though they are relatively new. There are probably just as many houses built in recent years, however, that will have to be replaced because of basic design and construction flaws.

E. TECHNOLOGY

It would be physically possible to "solve" the housing problems of native people by providing mass-produced units produced in southern Canada - but the solution would be subject to many of the same defects which plague present programs.

For the hinterland housing problem, recent approaches being used in developing countries suggest an "intermediate technology" of design, materials and construction. That is, local materials, labour and design are used in conjunction with some advanced technological devices. Processes for producing modules from low quality woods are currently being developed in Canada.

Housing can thus become supportive of economic development rather than separate from it or detrimental to it.

F. DESIGN

The design of housing for native people needs to reflect actual patterns of use in addition to the structural, lighting, cleanliness, and other requirements of any residential structure. The design process should be carried on with the active participation of native people if this objective is to be achieved. This clearly emerges from the discussion of participation above.

G. FINANCIAL ARRANGEMENTS

For rural native people and many urban dwellers, there is a necessity to consider the problems involved in provision of housing, preferably on an ownership basis, to the very poor, with seasonal incomes. The kinds of conditions, terms, and social expectations common for white housing finance are absent.

In fact, the present housing programs available to Canadians in general, through private and public financing

schemes, are not a real resource to the Indian, Eskimo and Metis people. These programs have been designed for persons in wage employment, with a steady income that allows them to make a down payment, regular monthly payments and to furnish and maintain their home at least to minimal standards. The vast majority of Canada's native people can not meet these requirements and so, for them, home ownership through private and public programs is beyond their reach.

Rental housing for low income families is seldom available to them because few such projects are located in the areas where they live. Even when such units are available, they are either unsuited to the family's needs or are denied to them because the project administrators or the other tenants are not willing to accept them.

It does not appear likely that the standard of living of the native people in Canada will improve so dramatically over the next decade that they will be able to exploit these general programs to any appreciable extent. If they are to be housed, the native people must look to special programs available through governments, but even these special programs will have to be modified significantly to be effective.

IV. VIABLE POLICY OPTIONS

In the light of the policy variables mentioned above, the following options have been developed for a 1971 approach to housing for native people:

(1) in immediate terms, the funding of all reasonable studies and project proposals developed by native people's organizations during the coming 6 months under the Housing Research and Development program.

(2) the development over the year 1971 of a major program of housing for Canada's native people, with the objective of largely eradicating the grossly substandard conditions that exist for them over the next 5 - 7 years. (this could involve a roughly estimated 50,000 units.)

(3) the termination of CMHC funds for existing

programs. This would seem to be indicated by the problems associated with such programs.

(4) the initiation of negotiations with provinces and native people on what should replace these programs.

A fast-starting alternative in this regard is the use of Section 35A in joint federal-provincial schemes to provide subsidized home ownership for native people. The Isolated Housing Program operated in Manitoba is an example of this, despite its drawbacks. Payments may be as little as \$5.00 per month and ownership is conferred after 15 years regardless of amount paid.

(5) the development of housing design, financial, and construction approaches which are geared to the social and economic needs of the very poor.

This could involve the Federal/provincial approach mentioned above or a legislatively sanctioned subsidized ownership program. It could also involve the use of non-profit and the cooperative sections of the Act to fund self-help housing. Funds would need to be provided either at reduced or written off interest rates. Up to 100% financing and/or capital grants would be required.

The use of land assembly funds either through the program itself or through Section 37 to aid specific federal-provincial initiatives would be of additional assistance in given locations.

The employment of the Prairie Region as a pilot region for developing such a program, with a substantial number of starts (2,000 - 5,000) to be initiated by the end of 1971.

(7) ultimately, the development of broad hinterland housing policies which relate to the technologies and culture of developing localities in Canada.

The process of policy change in the field of housing for native people must be especially sensitive to the views and problems of the "client group" involved if resulting programs are to be effective in more than a

crude units-on-the-ground sense. Thus the alternatives presented below are in effect choices to initiate a flexible decision process and to develop potential program resources rather than to establish or reject a program as such.

To this end the simple process model on the following page is provided.

V. THE BROADER CONTEXT - HOUSING AND NATIVE SOCIAL DEVELOPMENT

Providing housing alone will not "solve" any of the hard core social and cultural problems of Canada's native people. Years of dependency and discrimination cannot be erased by any given improvement even if made in the context of active involvement. But housing can be used strategically to assist with a general process of native social development by providing a base for health, education, cultural pride, and self-respect.

A MODEL FOR DEVELOPING NEW PROGRAMS OF HOUSING FOR NATIVE PEOPLE

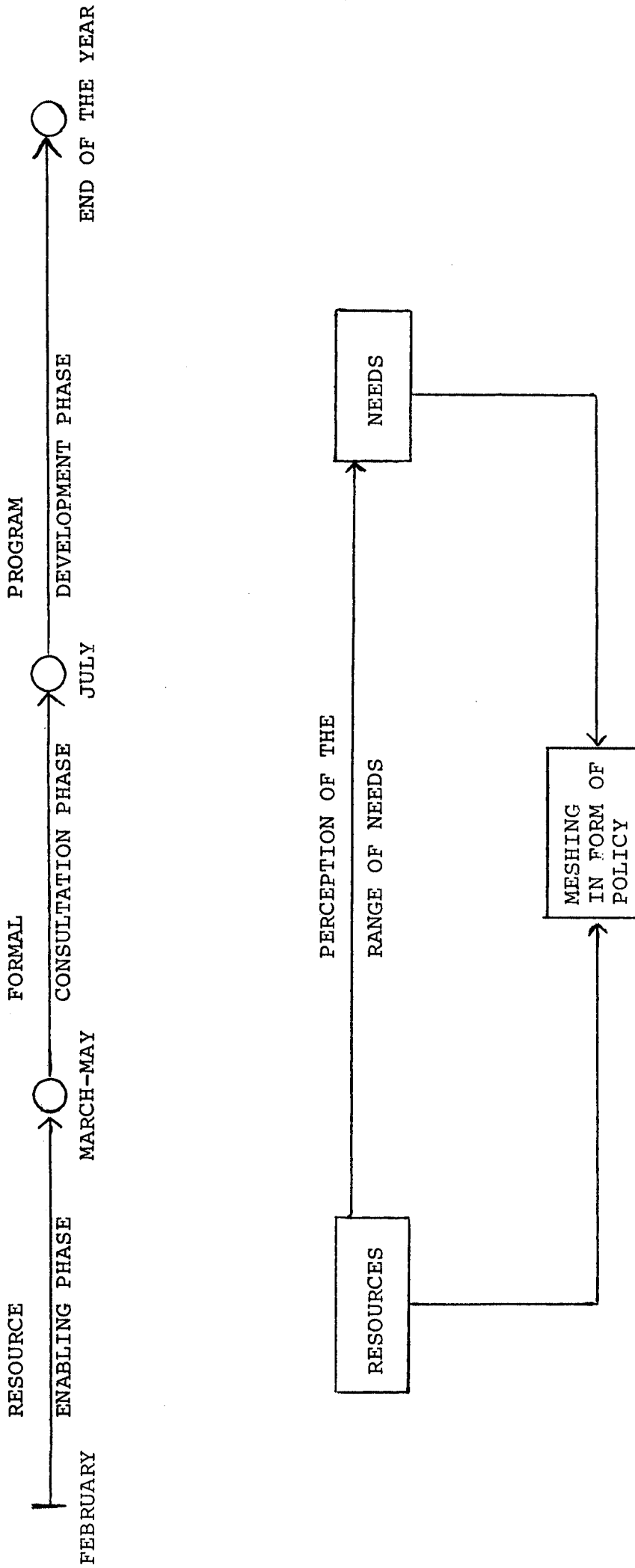

APPENDIX A

Results of a Survey Conducted
by the Metis Nation of
Saskatchewan

GRAPH I - SASKATCHEWAN METIS HOUSING BY FLOOR AREA
- showing the percentage of units presently occupied by Metis people
falling into each floor area category.

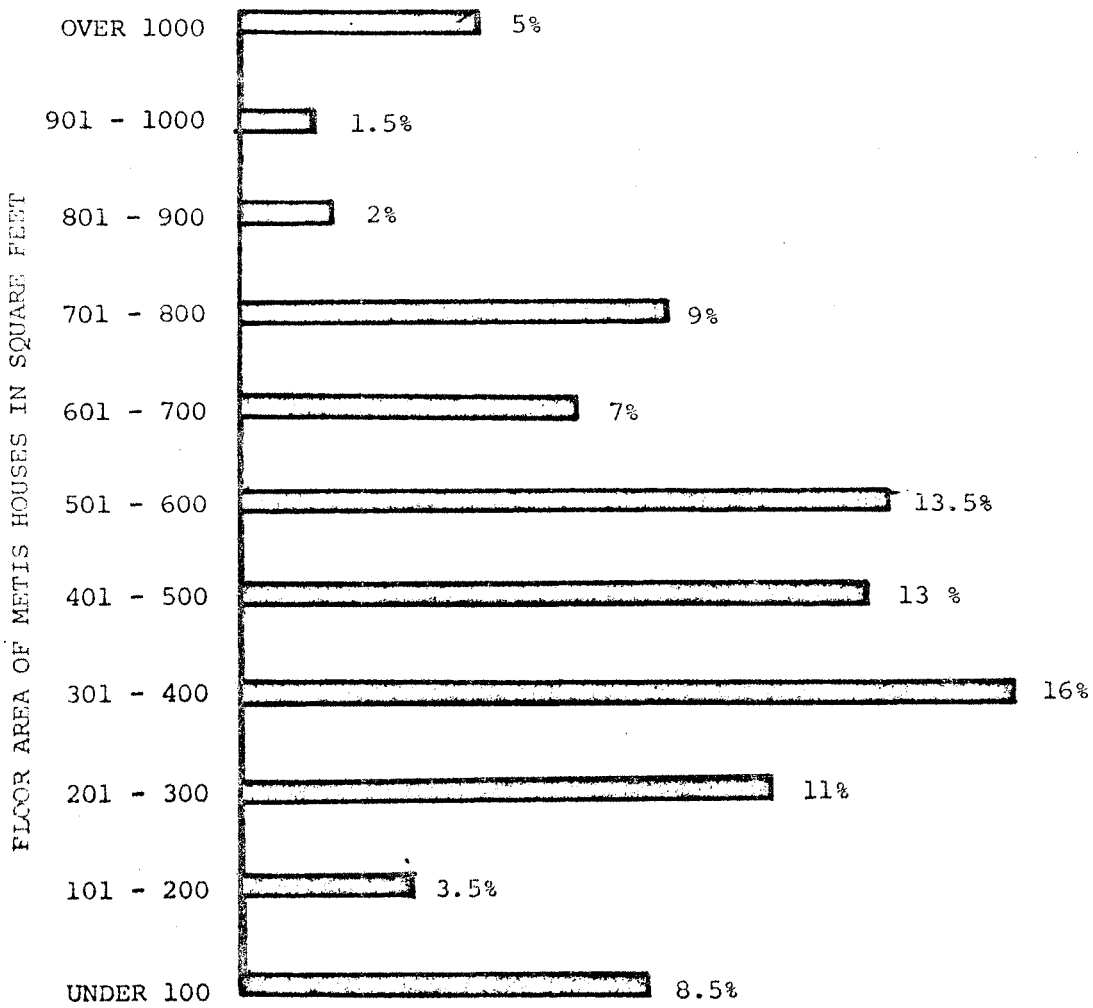

NOTE: Total does not equal 100% due to "No Response" on some questionnaires.

GRAPH II - SASKATCHEWAN METIS HOUSING BY NUMBER OF INHABITANTS PER UNIT
- Showing the percentage of units with the actual present number of occupants.

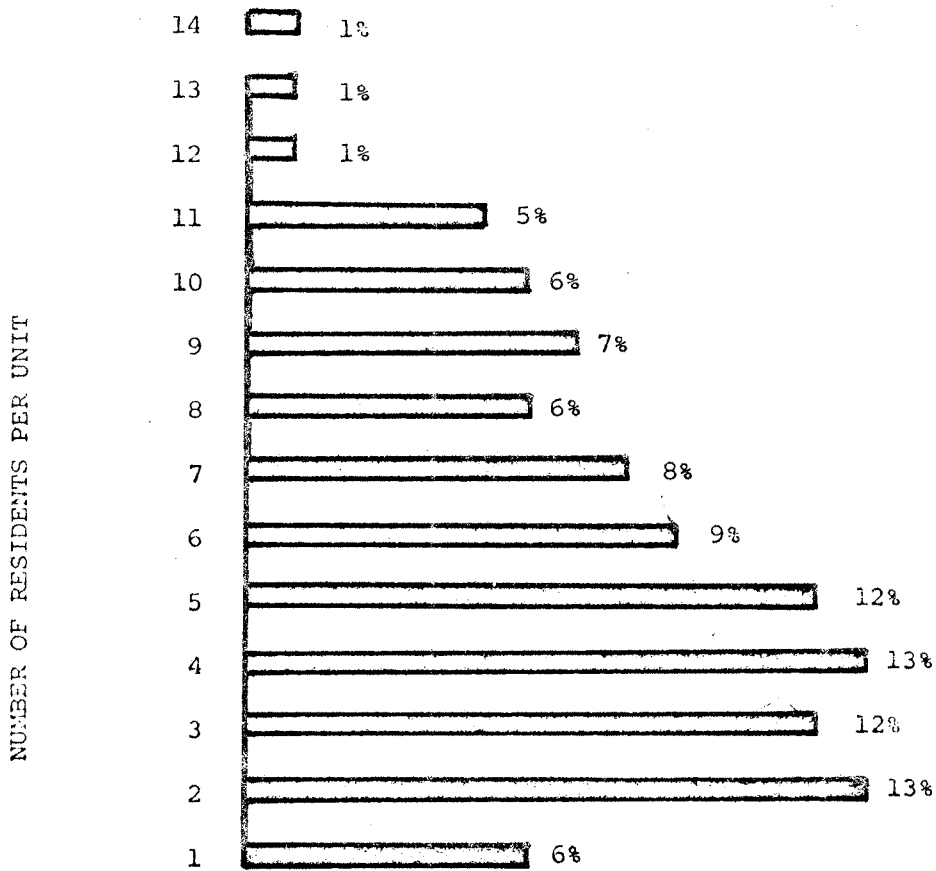

GRAPH 111 - AVERAGE ANNUAL INCOME AND EXPENDITURES OF SASKATCHEWAN METROPOLITAN FAMILY UNITS
 - showing the percentage of family units which have annual incomes and expenditures as indicated.

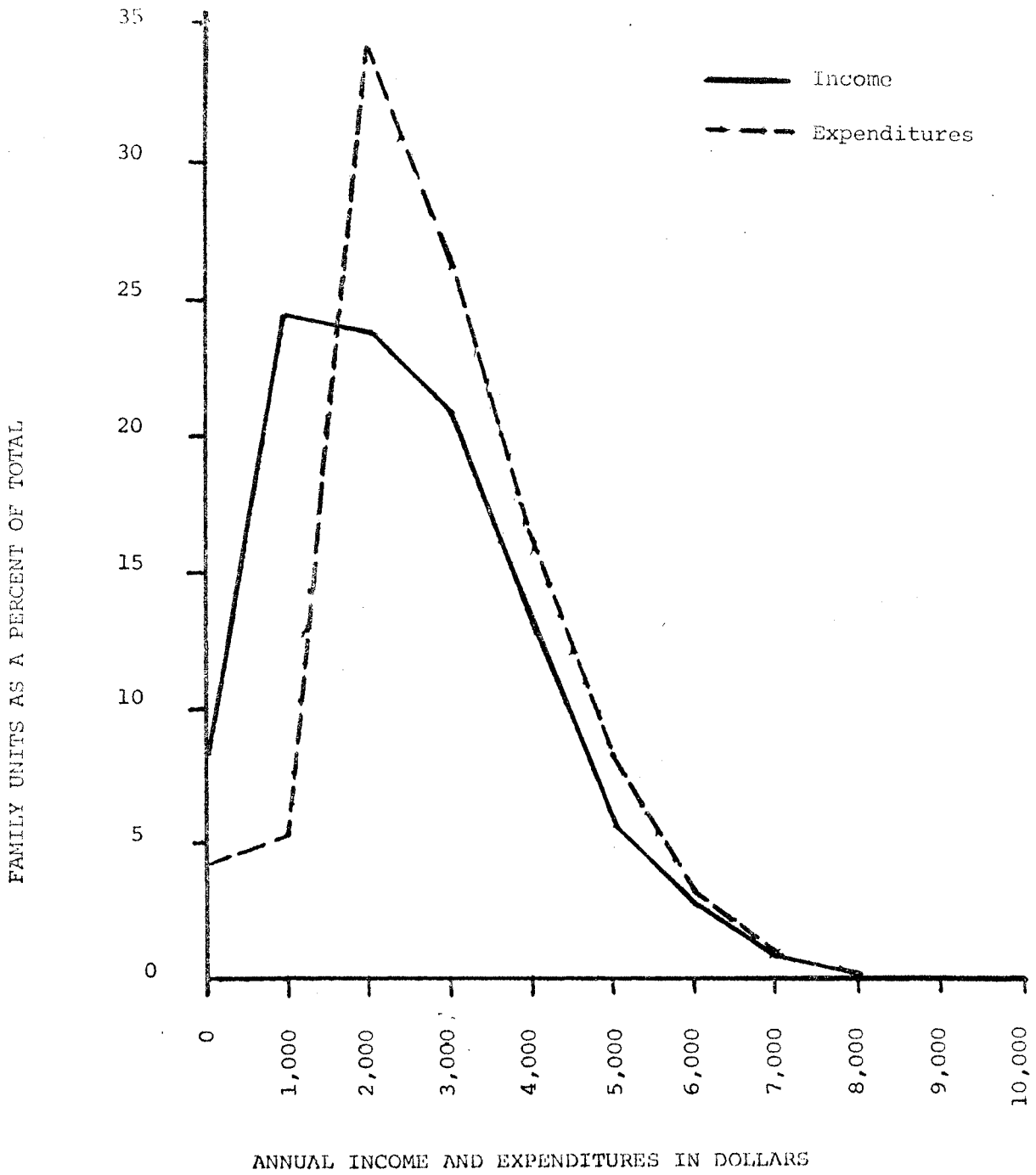





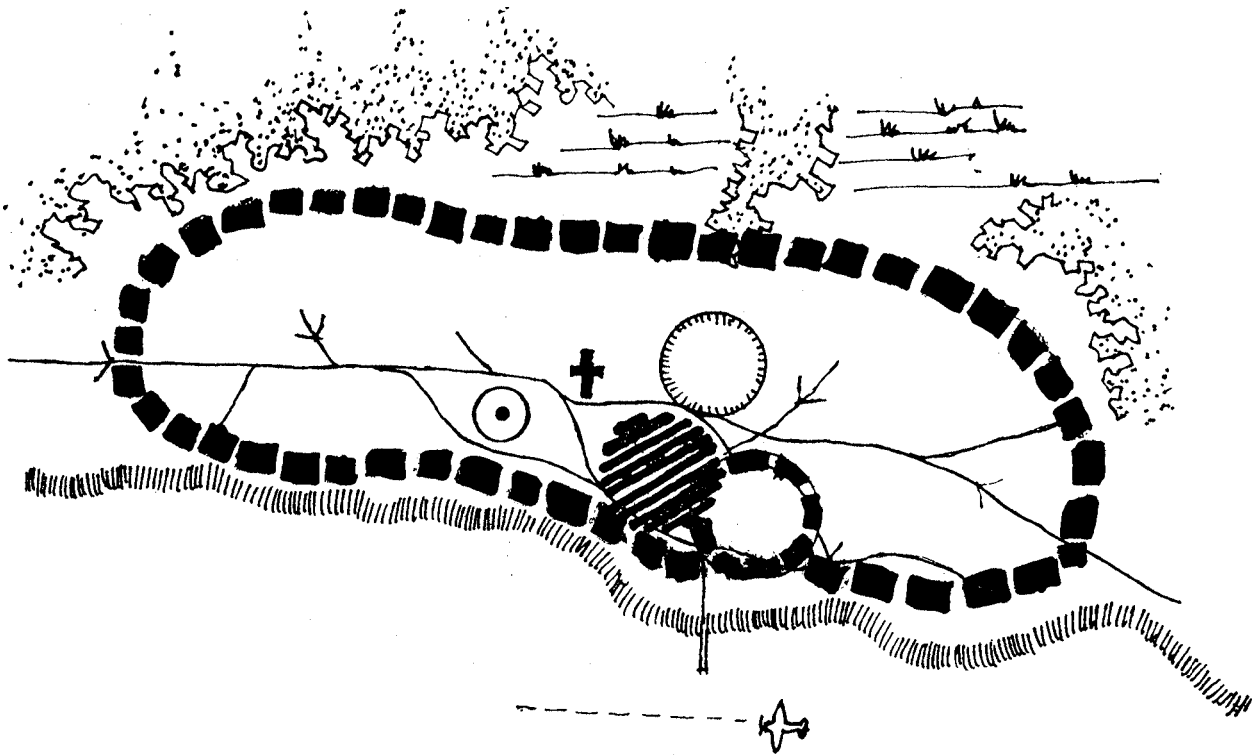



APPENDIX B

Excerpts from Kennedy/Smith Associates
Housing Study of Isolated Communities
and Indian Reserves in the Prairie
Provinces



LEGEND

- | | | | |
|--|-----------------------------|---|--------------------------|
|  | HOSPITAL OR NURSING STATION |  | WHITE HOUSING COMPONENT |
|  | SCHOOL |  | NATIVE HOUSING COMPONENT |
|  | CHURCH(ES) OR MISSION |  | TRAIL (FOOTPATH) |
|  | STORE(S) |  | LAKE OR RIVER SHORE |

HYPOTHETICAL COMMUNITY DIAGRAM • ISOLATED NORTHERN NATIVE SETTLEMENT

LA RONGE, SASKATCHEWAN

APPROXIMATE RESERVE BOUNDARY

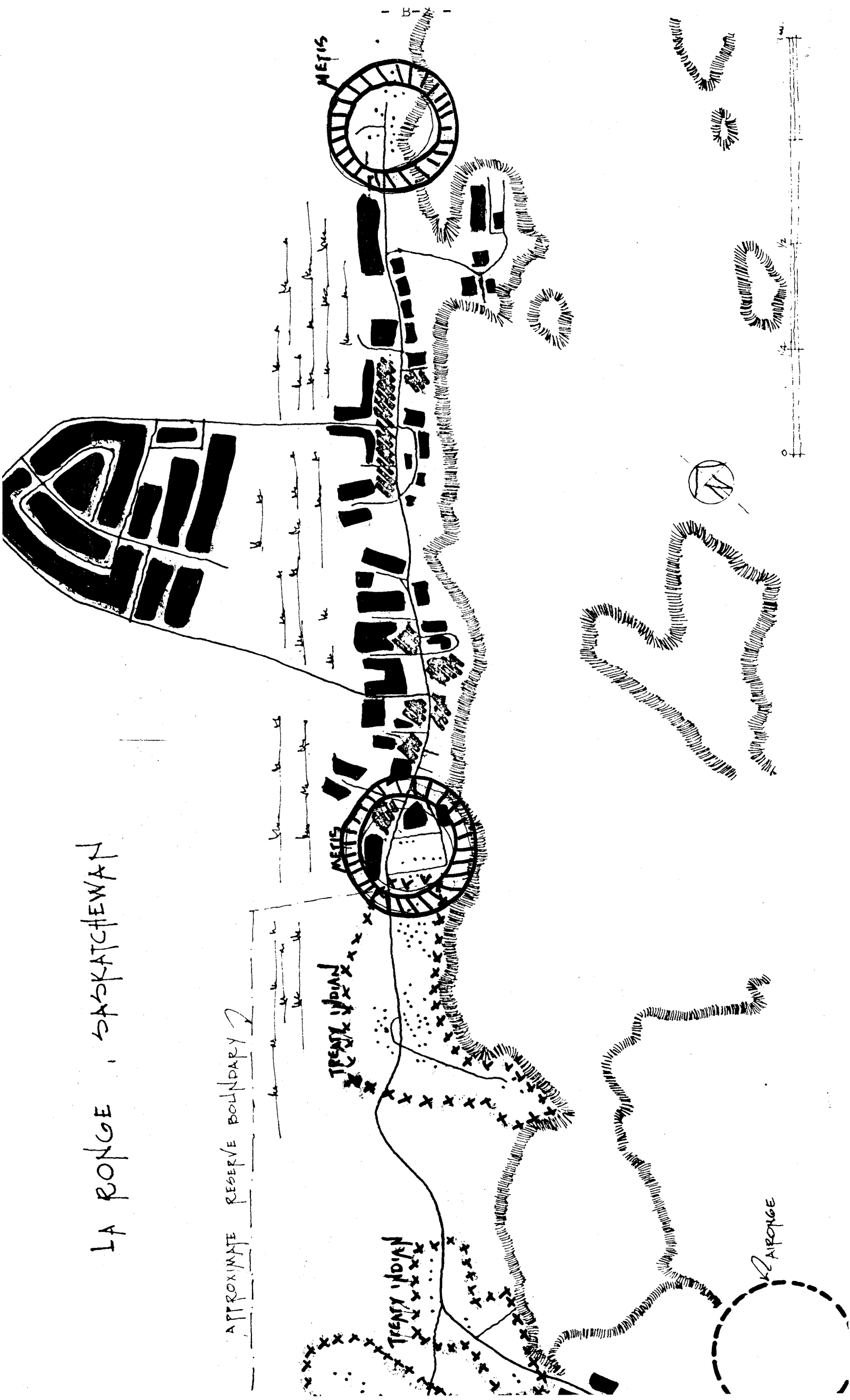

La Ronge, Saskatchewan

- Location - 180 miles North of Prince Albert - located on the north shore of Lac La Ronge.
- Population - Town has a mixture of Indian, Metis and white population.
White and Metis 2,223 in town
(An estimate of 200 - 300 Metis in the Municipality)
- Treaty Indian 825
Total 3,048 (estimate)
- Employment - Native people seasonally employed in a range of jobs including trapping, guiding, construction, prospecting, line cutting and sugar beet farms (Southern Alberta).
- Permanent employment available in mining and construction (15 Treaty Indians employed in mining operation during December 1966).
- La Ronge Industries employs a number of people in a training program.
- Access and Communication - Permanent road from Prince Albert.
- 2 or 3 airline companies operating out of La Ronge.
- Contact by radio, telephone and teletype.
- Community Structure - A very defined development with clusters of Indian housing outside the westerly extremity of the town and some Metis housing to the east.
- New housing subdivisions north of the centre of town and near the airport (Air Ronge) (Growth is the result of mining operations among other activities.)
- Community Facilities - Town - 5 stores
- 1 hospital
- 4 schools (60 children in res. school in P.A.)
- 1 curling rink
- 4 churches
- cafes
- halls
- Reserve - Band Hall only.
- Community Services - Water supplied from lake and wells (no piped water system in town).
- Critical pollution problems.
- Some pumped septic tanks used in town, otherwise outdoor privies or chemical toilets.
- Electricity in town but none on reserve.
- New subdivision built by the mining company has both water and sewage system (lagoon).
- Housing - Much lower housing standards in Indian and Metis areas as compared to white component. Very poor housing in some locations.
- Traditional Indian and Metis homes are either log, frame or shacks.
- 7 new Indian Affairs houses constructed in 1966 (frame).

POINT OF METIS

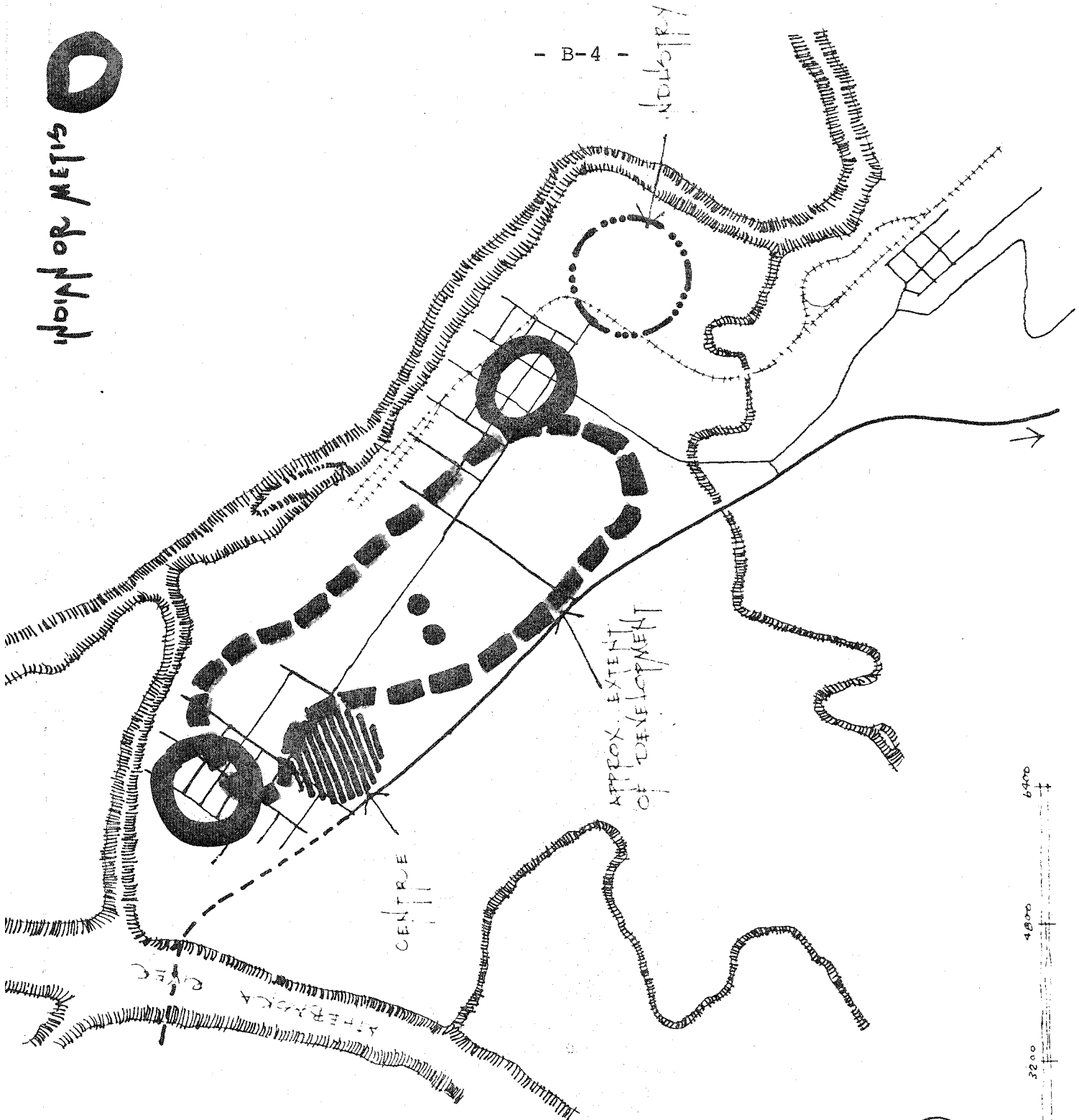

CENTRE

APPROX. EXTENT OF DEVELOPMENT

AMERBOKA RIVER

NOLDSBY

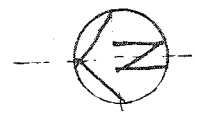

APPROX. SCALE

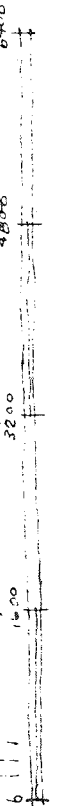

FORT Mc MURRAY, ALBERTA

Fort McMurray, Alberta

- Location - 287 miles north of Edmonton (by road)
- Population - estimates (1965)
- | | |
|----------|------------------|
| - White | 2,780 |
| - Indian | 120 |
| - Metis | 600 |
| - Total | 3,500 (estimate) |
- Employment - Mining (Great Canadian Oil Sands).
- Construction (Canadian Bechtel).
- Service industries.
- Some commercial, government and social services (approximately 1,400 men employed in oil industry).
- Access and Communication - Road, rail; scheduled air service daily (airport)
- Radio, telephone and telegraph.
- Community Structure - Town established at existing Indian villages of Fort McMurray and Waterways.
- Town has retained linear pattern and an "infill" and expansion process is underway.
- Development is fairly spread out and native housing areas are fairly strongly defined.
- Community Services - All utilities and services
- Community Facilities - A range of shopping facilities (97 stores) that serve the region.
- 4 - 6 churches.
- 1 hospital (34-bed)
- Community hall, arena, curling rink, hotels, service, commercial, etc.
- 2 schools (1 under construction)
- Vocational school (5 classrooms) (50 in residence).
- Housing - 941 dwelling units, the majority of which are good.
- Some shacks and a large number of temporary units.
- Majority of native housing is of a low standard (26 new houses constructed by Metis under a co-operative loan).
- Rents and costs high (minimum rent for small suite - \$100/month. Shacks rent for \$30-\$40/month).

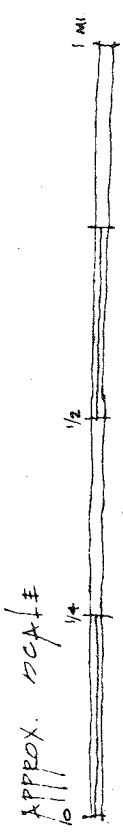
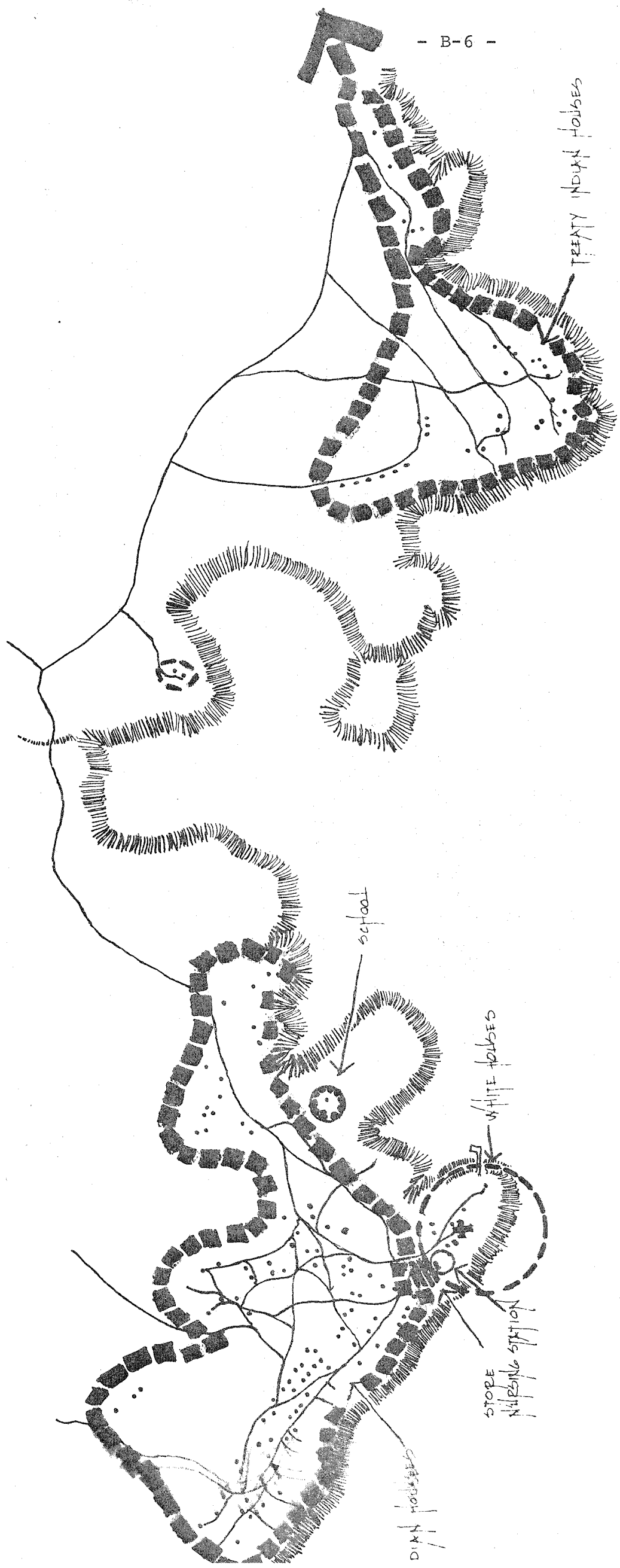

NELSON HOUSE, MANITOBA

Nelson House, Manitoba

- Location - Located 40 air miles from Thompson, Manitoba.
- Population - Treaty Indian - 900
- Some white residents - teachers
- store manager
- priest and minister
- Employment - Limited fishing and trapping
- Construction (local needs)
- Welfare payments high
- Access and Communication - Charter air service
- Radio and 2-way radio
- Community Structure - Two separate communities centred around the two churches, Poplar Point (U.C.) and Dog Point (R.C.)
- Basically a linear development at Poplar Point with some housing arranged in clusters.
- Community Facilities - 1 store (H. B. C. at Poplar Point)
- 2 schools (1 at Poplar Point
1 at Dog Point)
- 1 nursing station
- 2 churches
- 1 Band Hall
- Community Services - Water supply from the lake (pollution problems on the shoreline)
- No sewage system (outdoor privies)
- 2 or 3 local diesel power plants serving schools and store.
- Housing - Mainly log houses. The majority poor to average condition.

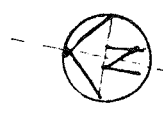
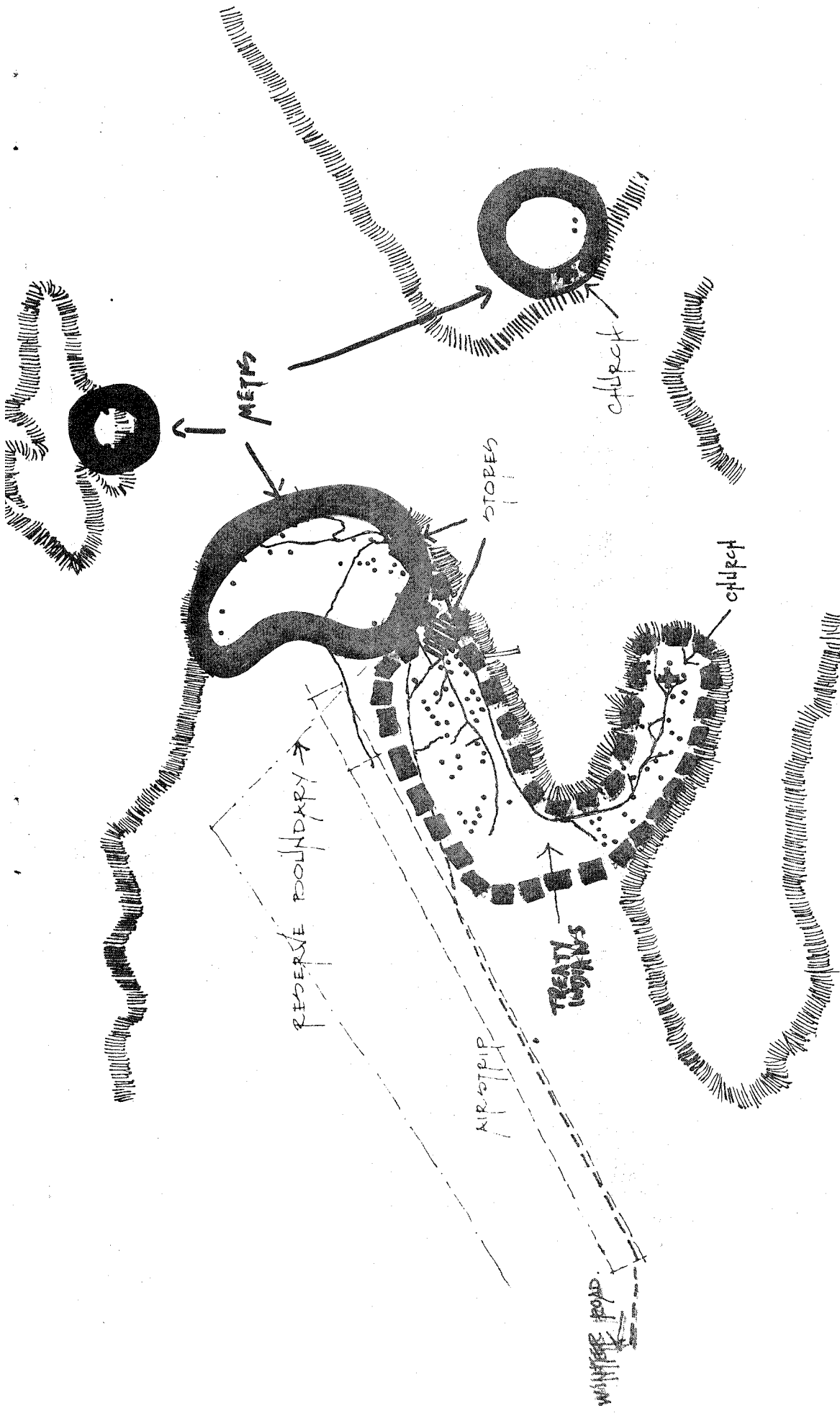

APPROX. SCALE



STANLEY MISSION, SASK.

Stanley Mission, Saskatchewan

Location - 37 miles by air and 44 miles by water from La Ronge, Saskatchewan.
Located on the South end of Mountain Lake on the Churchill River.

Population - A mixed Indian and Metis community.

Indian	600	(31 living off reserve)
Metis	100	

Total population 700 approximately

Employment - Principally trapping, guiding and construction.
- Some fishing.

Access - By water (during summer) and winter road from La Ronge.
- Charter air service from La Ronge.

Community Structure - A fairly compact settlement with a few dwellings located on the islands or across the river.

Community Facilities - 2 stores (H.B.C. and Co-op)
- 2 churches
- 1 elementary school (110 children in residential school in P.A.)
- 1 Band Hall
- A "Cabin Clinic" (regular visits by Indian Health nurse - 4-5 times monthly)

Community Services - No community electrical service. Individual diesel power plants serve the co-op store, The Hudson Bay Store and the school.
- Water is carried by pail from the Churchill River to the native houses (some health problems as a result of shoreline pollution).
- Sewage disposal by outdoor privies.
- No telephone service.

Housing - A housing construction program is being carried out by Indian Affairs for Treaty Indians and by the Department of Northern Affairs for Metis population.
- 14 new frame houses had been built by Indian Affairs up to 1966.
- 11 squared log houses had been built under a provincial grant to the Metis.

THE PAS, MANITOBA.

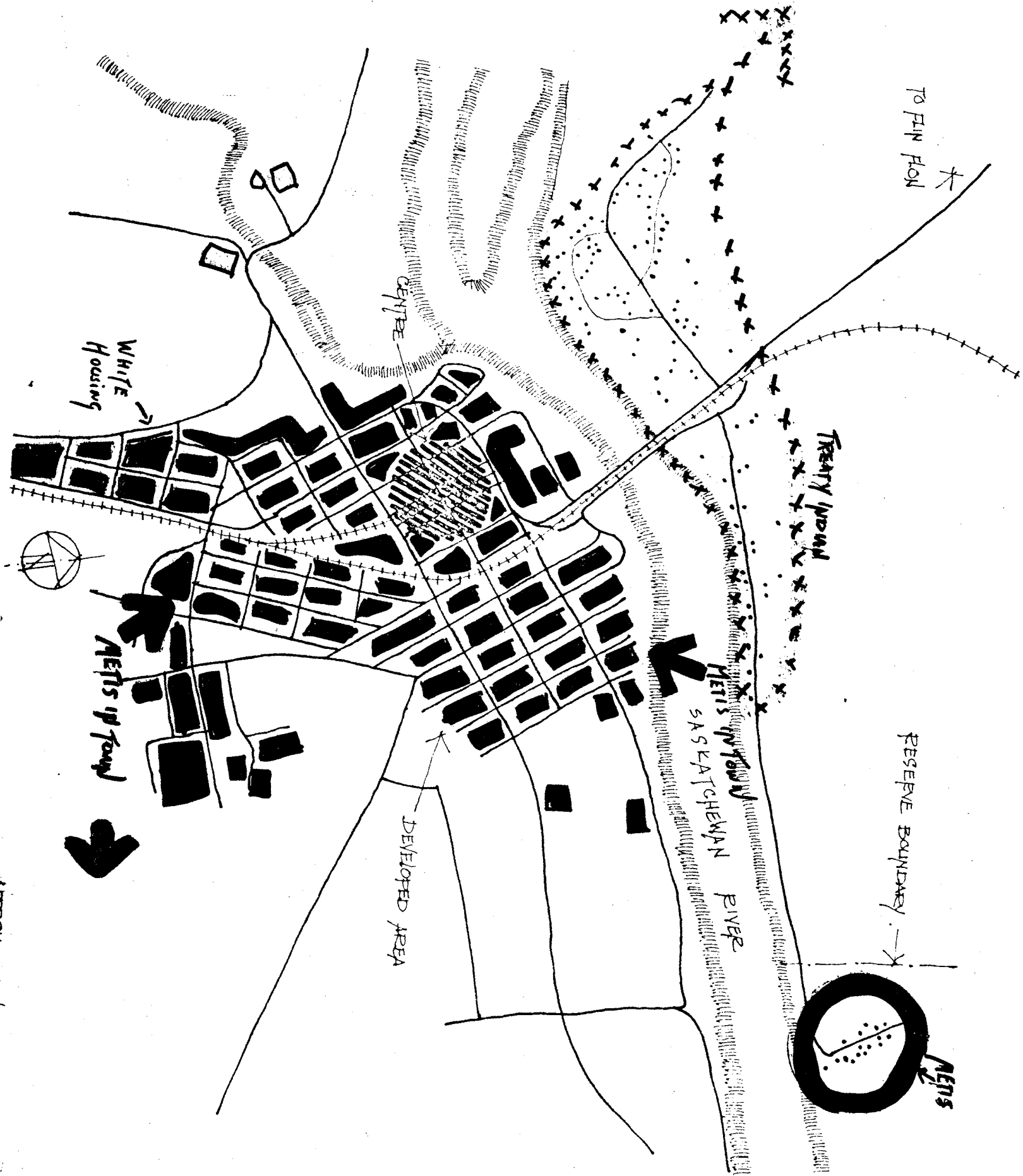

The Pas, Manitoba

- Location - On the Saskatchewan and Carrot Rivers, 20 miles east of the Manitoba-Saskatchewan border.
- Population - Town is a mixture of White, Indian and Metis.
- Town population (1966 census) 4,671
- Treaty Indian population 940
- Metis population 180 +
(estimated 30 Metis families located in the district.) -
- Employment - Railway maintenance; highway construction and maintenance; government employment; lumbering; future pulp mill construction; service industries and commercial services.
- Access and Communication - Permanent road from Winnipeg.
- Rail connection (C.N.R.).
- Daily scheduled air service (airport), chartered airways.
- Radio, Television and Telegraph.
- Community Structure - Fairly densely developed town on the south side of the Saskatchewan River.
- Indians and some Metis are scattered in groups or individually north of the river. The Reserve is divided in four distinct areas: The Pas East, The Pas West, Big Eddy and Carrot River and the Metis settlements are to the west (Umpherville), at Big Eddy, and south of town.
- Community Facilities - A range of shopping facilities, hotels, beer parlors are located in the town.
- Technical school.
- Hospital (100 beds).
- School and community centres.
- Reserve - 1 church
1 kindergarten (20 students)
- Community Services - Water and sewerage system in town but none on reserve. Water is hauled from town to each house on reserve.
- Electricity available.
- Housing - General standard of Indian and Metis homes poor in comparison to other dwellings in town.
- Log and frame construction - 119 units on reserve.
(Detailed housing survey of Indian reserve conducted in April 1966).